

SUPER MULTIPLE JUNCTION (SMJ)

Installation

Behind fuse block

SMJ (Main harness-Engine room harness)

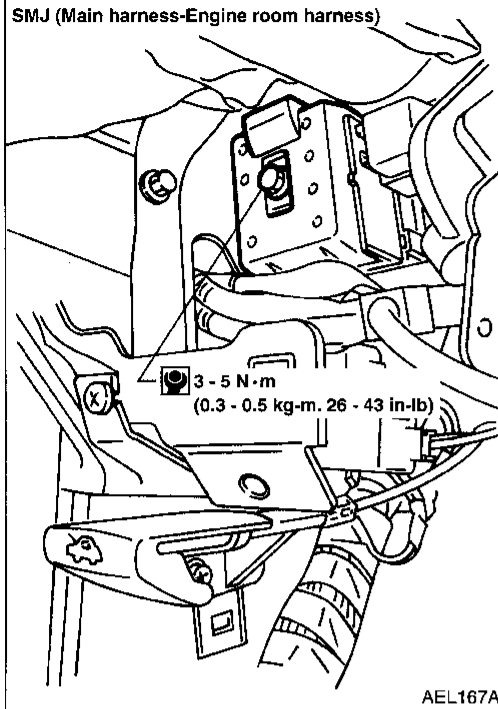

Installation

To install SMJ, tighten bolts until orange "fultight" mark appears and then retighten to specified torque as required.

NDELD143

 : 3 - 5 N·m (0.3 - 0.5 kg·m, 26 - 43 in-lb)

CAUTION:

Do not overtighten bolts, otherwise, they may be damaged.

SUPER MULTIPLE JUNCTION (SMJ)

Terminal Arrangement

Terminal Arrangement

NDEL0144

MAIN HARNESS

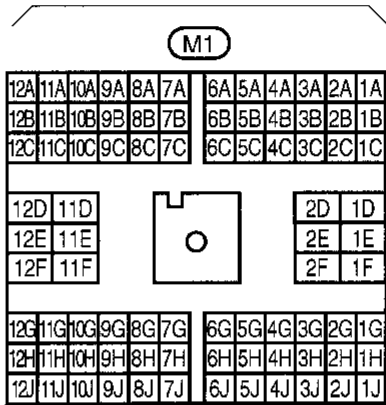

ENGINE CONTROL HARNESS

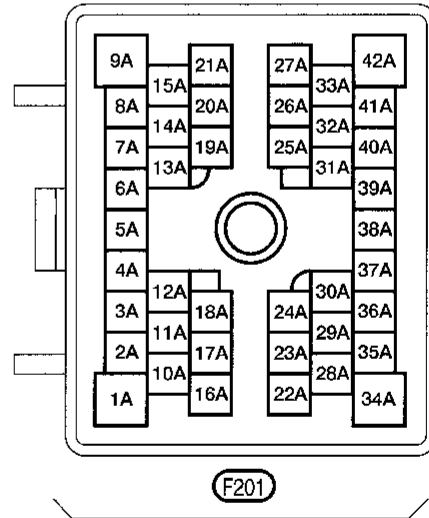
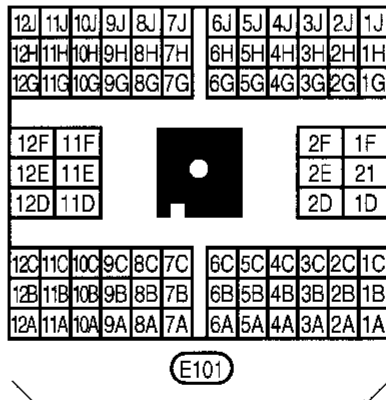
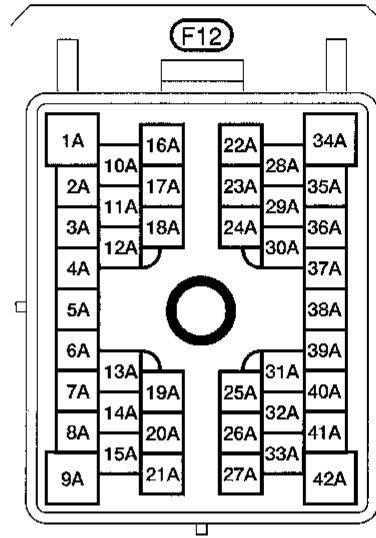

ENGINE ROOM HARNESS

ENGINE CONTROL SUB-HARNESS

FUSE BLOCK

Terminal Arrangement

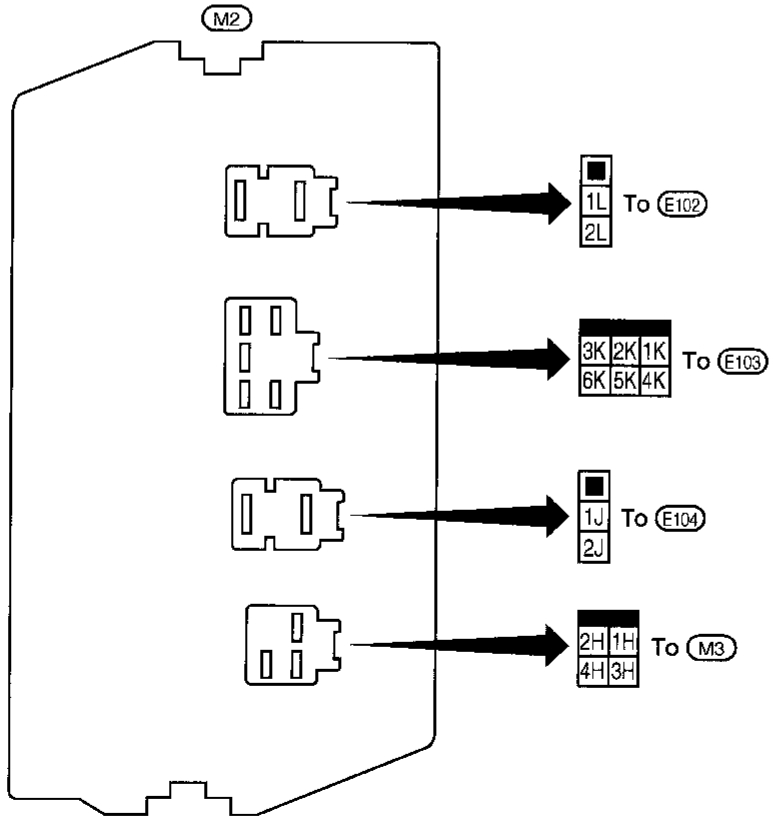
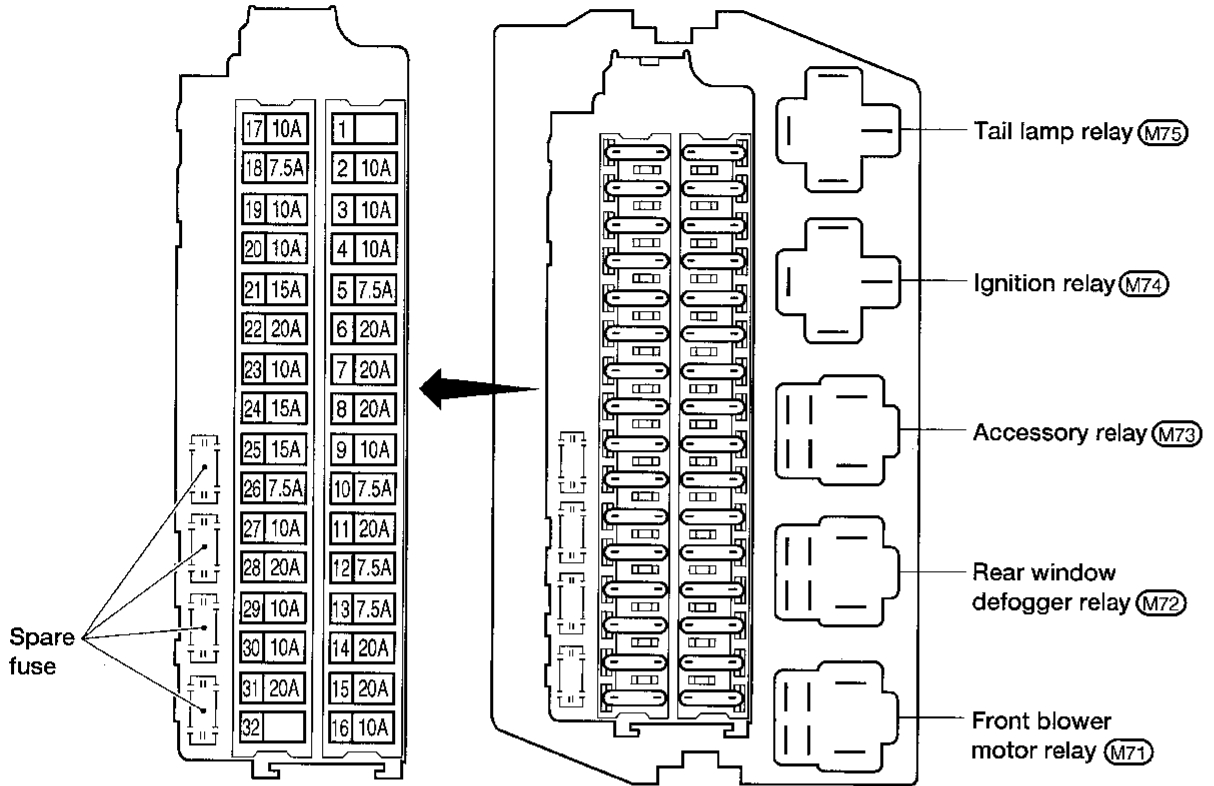

FUSE AND FUSIBLE LINK BOX

Terminal Arrangement

Terminal Arrangement

NDEL0146

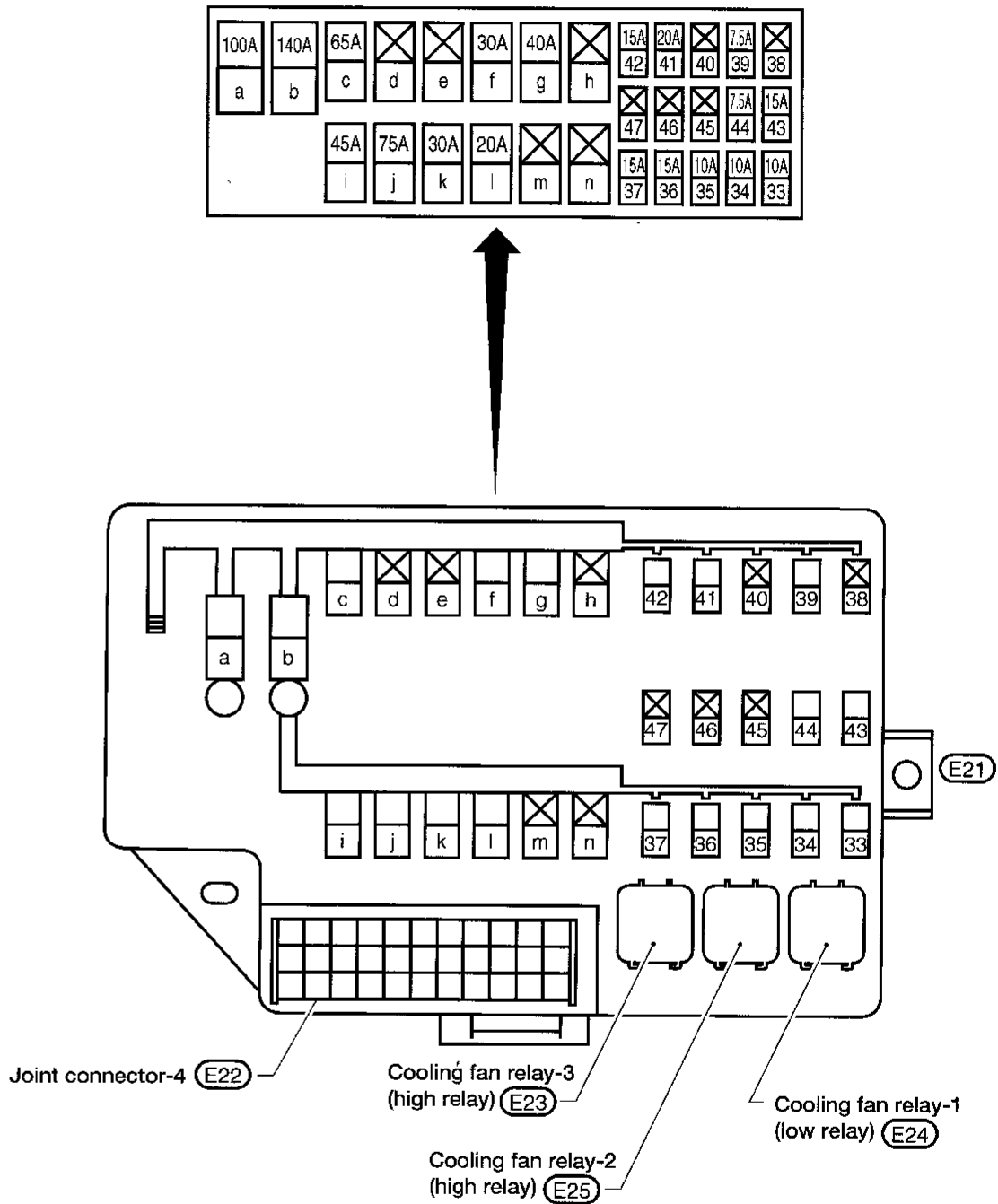

JOINT CONNECTOR

Terminal Arrangement

Terminal Arrangement

NDEL0147

J/C-1 (M14)

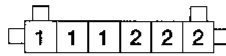
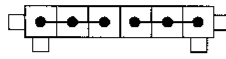

J/C-2 (M9)

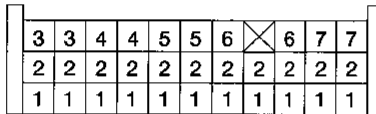
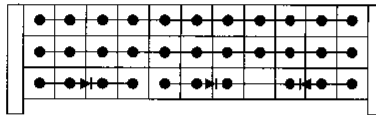

J/C-3 (M20)

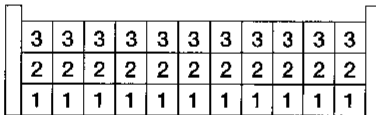
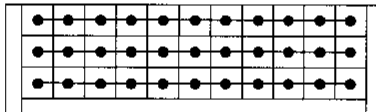

J/C-4 (E22)

