

# STEERING SYSTEM

# SECTION ST

GI  
MA  
EM  
LC  
EC  
FE  
CL  
MT  
AT  
AX  
SU  
BR  
ST  
RS  
BT  
HA  
SC  
EL  
IDX

## CONTENTS

<b>PRECAUTIONS</b> .....	2	Inspection.....	14
Supplemental Restraint System (SRS) "AIR BAG" and "SEAT BELT PRE-TENSIONER" .....	2	TILT MECHANISM .....	14
Precautions for Steering System.....	2	<b>POWER STEERING GEAR AND LINKAGE</b> .....	15
<b>PREPARATION</b> .....	3	Components.....	15
Special Service Tools .....	3	Removal and Installation .....	16
Commercial Service Tool.....	4	Disassembly.....	18
<b>NOISE, VIBRATION AND HARSHNESS (NVH)</b>		Inspection.....	18
<b>TROUBLESHOOTING</b> .....	5	BOOT .....	18
NVH Troubleshooting Chart.....	5	TIE-ROD OUTER AND INNER SOCKETS.....	19
<b>ON-VEHICLE SERVICE</b> .....	6	Assembly .....	19
Checking Steering Wheel Play.....	6	<b>POWER STEERING OIL PUMP</b> .....	21
Checking Neutral Position on Steering Wheel .....	6	QG18DE .....	21
PRE-CHECKING.....	6	COMPONENTS .....	21
CHECKING .....	6	PRE-DISASSEMBLY INSPECTION .....	21
Front Wheel Turning Angle.....	6	DISASSEMBLY.....	21
Checking Gear Housing Movement .....	6	INSPECTION.....	22
Checking and Adjusting Drive Belts .....	7	ASSEMBLY .....	22
Checking Fluid Level .....	7	SR20DE .....	24
Checking Fluid Leakage.....	7	COMPONENTS .....	24
Bleeding Hydraulic System.....	7	PRE-DISASSEMBLY INSPECTION .....	24
Checking Steering Wheel Turning Force .....	8	DISASSEMBLY.....	24
Checking Hydraulic System.....	9	INSPECTION.....	25
<b>STEERING WHEEL AND STEERING COLUMN</b> .....	10	ASSEMBLY .....	25
Components.....	10	<b>SERVICE DATA AND SPECIFICATIONS (SDS)</b> .....	28
Removal and Installation .....	10	General Specifications.....	28
STEERING WHEEL .....	10	Steering Wheel .....	28
STEERING COLUMN.....	11	Steering Column .....	28
Disassembly and Assembly.....	13	Steering Gear and Linkage .....	29
		Power Steering .....	30

## PRECAUTIONS

Supplemental Restraint System (SRS) "AIR BAG" and "SEAT BELT PRE-TENSIONER"

---

### Supplemental Restraint System (SRS) "AIR BAG" and "SEAT BELT PRE-TENSIONER"

NIST0001

The Supplemental Restraint System such as "AIR BAG" and "SEAT BELT PRE-TENSIONER" used along with a seat belt, helps to reduce the risk or severity of injury to the driver and front passenger for certain types of collision. The SRS system composition which is available to NISSAN MODEL B15 is as follows:

- For a frontal collision  
The Supplemental Restraint System consists of driver air bag module (located in the center of the steering wheel), front passenger air bag module (located on the instrument panel on passenger side), front seat belt pre-tensioners, a diagnosis sensor unit, warning lamp, wiring harness and spiral cable.
- For a side collision  
The Supplemental Restraint System consists of front side air bag module (located in the outer side of front seat), side air bag (satellite) sensor, diagnosis sensor unit (one of the components of air bags for a frontal collision), wiring harness, warning lamp (one of the components of air bags for a frontal collision).

Information necessary to service the system safely is included in the **RS section** of this Service Manual.

#### **WARNING:**

- To avoid rendering the SRS inoperative, which could increase the risk of personal injury or death in the event of a collision which would result in air bag inflation, all maintenance must be performed by an authorized NISSAN dealer.
- Improper maintenance, including incorrect removal and installation of the SRS, can lead to personal injury caused by unintentional activation of the system. For removal of Spiral Cable and Air Bag Module, see the RS section.
- Do not use electrical test equipment on any circuit related to the SRS unless instructed to in this Service Manual. Spiral cable and wiring harnesses covered with yellow insulation tape either just before the harness connectors or for the complete harness are related to the SRS.

### Precautions for Steering System

NIST0003

- Before disassembly, thoroughly clean the outside of the unit.
- Disassembly should be done in a clean work area. It is important to prevent the internal parts from becoming contaminated by dirt or other foreign matter.
- For easier and proper assembly, place disassembled parts in order on a parts rack.
- Use nylon cloths or paper towels to clean the parts; common shop rags can leave lint that might interfere with their operation.
- Before inspection or reassembly, carefully clean all parts with a general purpose, non-flammable solvent.
- Before assembly, apply a coat of recommended Genuine Nissan PSF II or equivalent to hydraulic parts. Petroleum jelly may be applied to O-rings and seals. Do not use any grease.
- Replace all gaskets, seals and O-rings. Avoid damaging O-rings, seals and gaskets during installation. Perform functional tests whenever designated.

# PREPARATION

Special Service Tools

## Special Service Tools

NIST0004

The actual shapes of Kent-Moore tools may differ from those of special service tools illustrated here.

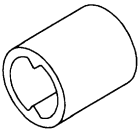
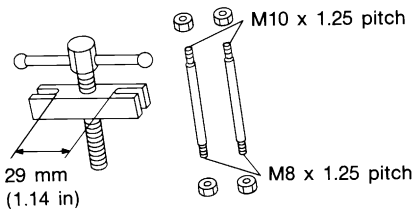
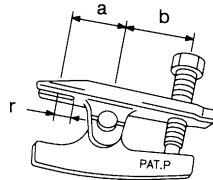
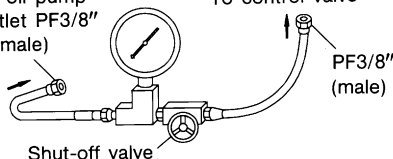
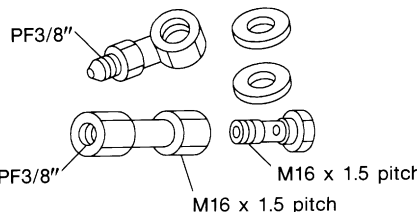
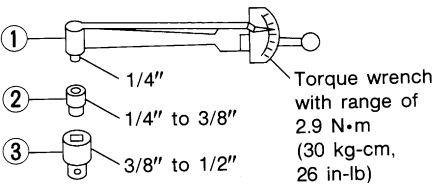
Tool number (Kent-Moore No.) Tool name	Description		GI
KV48101100 (J26364) Torque adapter		Measuring pinion rotating torque	MA
ST27180001 (J25726-B) Steering wheel puller		Removing steering wheel	EM
HT72520000 (J25730-B) Ball joint remover		Removing tie-rod and lower ball joint a: 33 mm (1.30 in) b: 50 mm (1.97 in) r: R11.5 mm (0.453 in)	LC
KV48103500 (J26357 and J26357-10) Pressure gauge		Measuring oil pressure	EC
KV48102500 (J33914) Pressure gauge adapter		Measuring oil pressure	FE
ST3127S000 1 GG91030000 (See J25765-B) Torque wrench 2 HT62940000 ( — ) Socket adapter 3 HT62900000 ( — ) Socket adapter		Measuring turning torque	CL

GI

MA

EM

LC

EC

FE

CL

MT

AT

AX

SU

BR

ST

RS

BT

HA

SC

EL

IDX

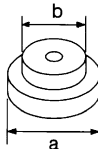

# PREPARATION

## Special Service Tools (Cont'd)

Tool number (Kent-Moore No.) Tool name	Description	
ST35300000 ( — ) Drift		Installing power steering pump oil seal <b>a: 49 mm (1.93 in) dia.</b> <b>b: 41 mm (1.61 in) dia.</b>
	NT073	

## Commercial Service Tool

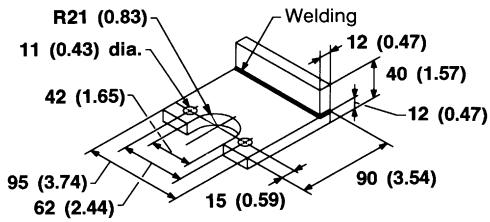
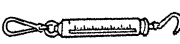
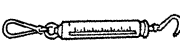
NIST0005

Tool number	Description	
Power steering pump attachment		Disassembling and assembling power steering pump Unit: mm (in)
	NT179	
Spring gauge		Measuring steering wheel turning force
	LST024	
Spring gauge		Measuring rack sliding force
	LST025	
10 mm Drift		Installing power steering pump snap ring
	LST027	

# NOISE, VIBRATION AND HARSHNESS (NVH) TROUBLESHOOTING

NVH Troubleshooting Chart

## NVH Troubleshooting Chart

NIST0006S01

Use the chart below to help you find the cause of the symptom. If necessary, repair or replace these parts.

Symptom		STEERING	Noise	x	x	x	x	x	x	x	x	x						x	x	x	x	x	x																					
			Shake																		x	x	x	x	x	x																		
Vibration																				x	x	x	x																					
Shimmy																				x	x	x	x	x																				
Judder																					x	x	x	x																				
Reference page			Fluid level	ST-7	Air in hydraulic system	ST-7	Tie-rod ball joint swinging force	ST-19	Tie-rod ball joint rotating torque	ST-19	Tie-rod ball joint end play	ST-19	Steering gear fluid leakage	ST-7	Steering wheel play	ST-6	Steering gear rack sliding force	ST-8	Drive belt looseness	Refer to <b>MA-16, MA-25.</b>	Improper steering wheel	ST-10	Improper installation or looseness or tilt lock lever	ST-14	Mounting rubber deterioration	ST-6	Steering column deformation or damage	ST-14	Improper installation or looseness of steering column	ST-11	Steering linkage looseness	ST-11	DRIVE SHAFT	<b>AX-3, NVH.</b>	AXLE	<b>AX-3, NVH.</b>	SUSPENSION	<b>SU-4, NVH.</b>	TIRES	<b>SU-4, NVH.</b>	ROAD WHEEL	<b>SU-4, NVH.</b>	BRAKES	<b>BR-6, NVH.</b>
Possible cause and SUSPECTED PARTS																																												

x: Applicable

GI  
MA  
EM  
LC  
EC  
FE  
CL  
MT  
AT  
AX  
SU  
BR  
ST  
RS  
BT  
HA  
SC  
EL  
IDX

# ON-VEHICLE SERVICE

## Checking Steering Wheel Play

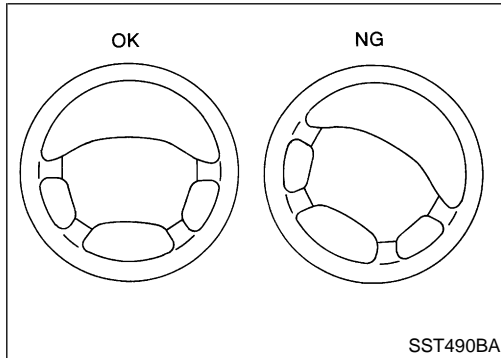
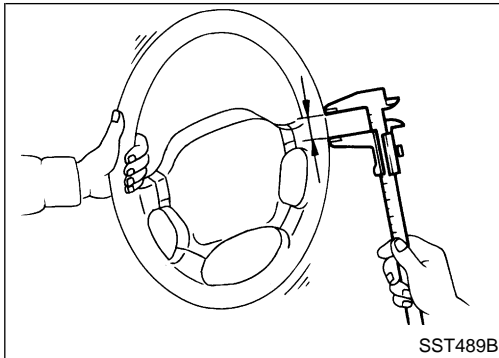

## Checking Steering Wheel Play

NIST0007

- With wheels in a straight-ahead position, check steering wheel play.

**Steering wheel play:**

**35 mm (1.38 in) or less**

- If it is not within specification, check the following for loose or worn components.

**Steering gear assembly**

**Steering column**

**Front suspension and axle**

## Checking Neutral Position on Steering Wheel

NIST0008

### PRE-CHECKING

NIST0008S01

- Make sure that wheel alignment is correct.

**Wheel alignment:**

**Refer to SU-13, "Front Wheel Alignment (Unladen\*1)".**

- Verify that the steering gear is centered before removing the steering wheel.

### CHECKING

NIST0008S02

1. Check that the steering wheel is in the neutral position when driving straight ahead.
2. If it is not in the neutral position, remove the steering wheel and reinstall it correctly.
3. If the neutral position is between two teeth, loosen tie-rod lock nuts. Turn the tie-rods by the same amount in opposite directions on both left and right sides.

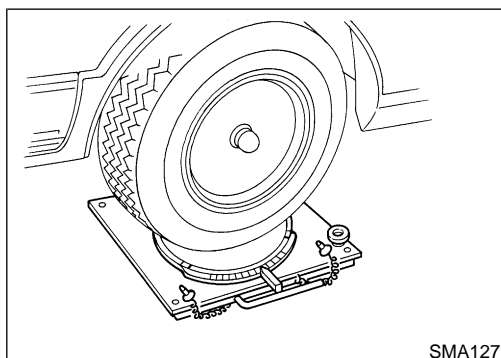

## Front Wheel Turning Angle

NIST0009

1. Rotate steering wheel all the way right and left; measure turning angle.

**Turning angle of full turns:**

**Refer to SU-13, SDS.**

2. If it is not within specification, check rack stroke.

**Rack stroke "S":**

**Refer to "Steering Gear and Linkage", ST-29.**

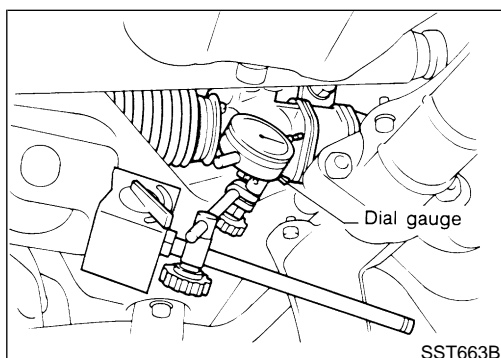

## Checking Gear Housing Movement

NIST0010

1. Check the movement of steering gear housing during stationary steering on a dry paved surface.

- Apply a force of 49 N (5 kg, 11 lb) to steering wheel to check the gear housing movement.

Turn off ignition key while checking.

**Movement of gear housing:**

**±2 mm (±0.08 in) or less**

2. If movement exceeds the limit, replace mount insulator after confirming proper installation of gear housing clamps.

## Checking and Adjusting Drive Belts

Refer to **MA-16** (QG18DE), **MA-25** (SR20DE), "Checking Drive Belts".

NIST0011

GI

MA

EM

LC

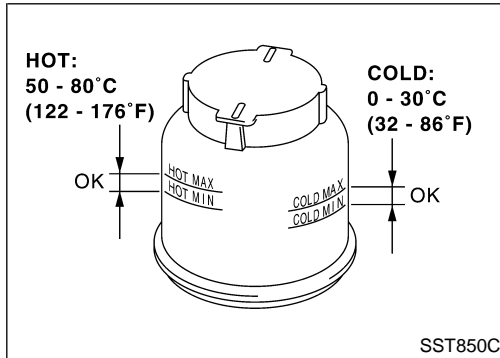

## Checking Fluid Level

Check fluid level, referring to the scale on reservoir tank. Use "HOT" range for fluid temperatures of 50 to 80°C (122 to 176°F).

NIST0012

EC

Use "COLD" range for fluid temperatures of 0 to 30°C (32 to 86°F).

FE

### CAUTION:

- Do not overfill.
- Recommended fluid is Genuine NISSAN PSF II or equivalent. Refer to **MA-13**, "Fluids and Lubricants".

CL

MT

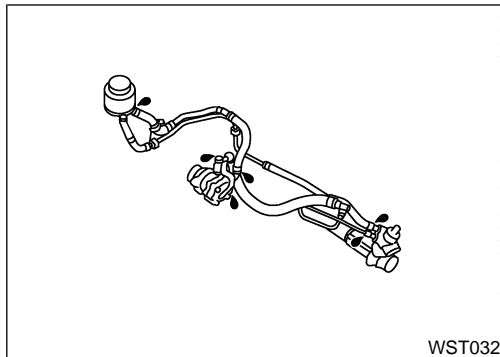

## Checking Fluid Leakage

Check the lines for improper attachment and for leaks, cracks, damage, loose connections, chafing and deterioration.

NIST0013

AT

1. Run engine between idle speed and 1,000 rpm.

AX

**Make sure temperature of fluid in oil tank rises to 60 to 80°C (140 to 176°F).**

SU

2. Turn steering wheel right-to-left several times.
3. Hold steering wheel at each "lock" position for five seconds and carefully check for fluid leakage.

BR

### CAUTION:

**Do not hold the steering wheel in a locked position for more than 15 seconds.**

ST

4. If fluid leakage at connectors is noticed, shut off engine, then loosen and retighten flare nut.

**Do not overtighten connector as this can damage O-ring, washer and connector.**

RS

5. If fluid leakage from power steering pump is noticed, check power steering pump. Refer to "Pre-disassembly Inspection", ST-21 (QG18DE), ST-24 (SR20DE).

BT

6. Check rack boots for accumulation of power steering fluid.

HA

## Bleeding Hydraulic System

1. Raise front end of vehicle until wheels are clear of the ground.
2. Add fluid into oil tank to specified level. Then quickly turn steering wheel fully to right and left and lightly touch steering stoppers.

NIST0014

SC

Repeat steering wheel operation until fluid level no longer decreases.

EL

3. Start engine. Repeat step 2. above.

IDX

- Incomplete air bleeding will cause the following to occur. When this happens, bleed air again.

## ON-VEHICLE SERVICE

### Bleeding Hydraulic System (Cont'd)

- a) Air bubbles in reservoir tank
- b) Clicking noise in oil pump
- c) Excessive buzzing in oil pump

Fluid noise may occur in the valve or oil pump. This is common when the vehicle is stationary or while turning the steering wheel slowly. This does not affect the performance or durability of the system.

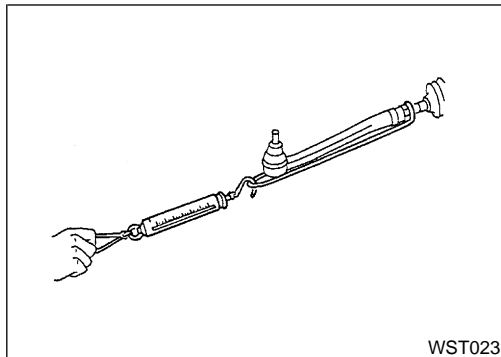
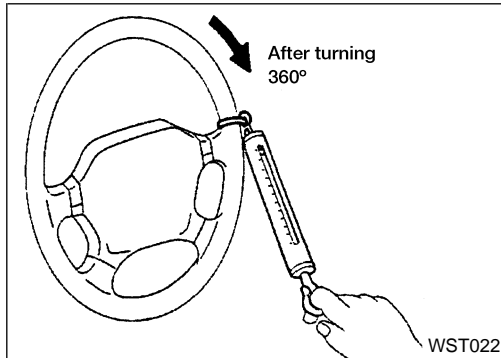

### Checking Steering Wheel Turning Force

NIST0015

1. Park vehicle on a level, dry surface and set parking brake.
2. Start engine.
3. Bring power steering fluid up to adequate operating temperature. [Make sure temperature of fluid is approximately 60 to 80°C (140 to 176°F).]

#### Tires need to be inflated to normal pressure.

4. Check steering wheel turning force when steering wheel has been turned 360° from the neutral position.

#### Steering wheel turning force:

**39 N (4 kg, 9 lb) or less**

5. If steering wheel turning force is out of specification, check rack sliding force.
  - a. Disconnect steering column lower joint and knuckle arms from the gear.
  - b. Start and run engine at idle to make sure steering fluid has reached normal operating temperature.
  - c. Pull tie-rod slowly to move it from neutral position to  $\pm 11.5$  mm ( $\pm 0.453$  in) at speed of 3.5 mm (0.138 in)/s. Check that rack sliding force is within specification.

#### Average rack sliding force:

**216 - 284 N (22 - 29 kg, 49 - 64 lb)**

#### Maximum force deviation:

**98 N (10 kg, 22 lb)**

- d. Check sliding force outside the above range at rack speed of 40 mm (1.75 in)/s.

#### Rack sliding force:

**Not more than 294 N (30 kg, 66 lb)**

#### Maximum force deviation:

**147 N (15 kg, 33 lb)**

6. If rack sliding force is not within specification, overhaul steering gear assembly.
7. If rack sliding force is OK, inspect steering column. Refer to "Inspection", ST-14.



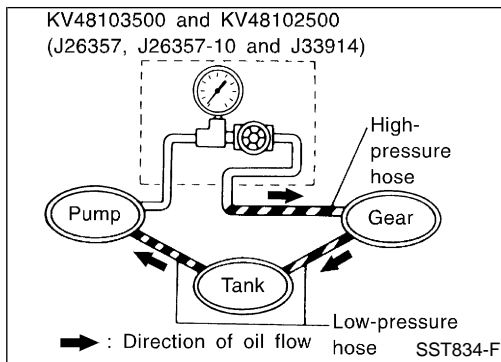

## Checking Hydraulic System

NIST0016

Before starting, check belt tension, driving pulley and tire pressure.

1. Set Tool. Open shut-off valve. Then bleed air. Refer to "Bleeding Hydraulic System", ST-7.
2. Run engine at idle speed or 1,000 rpm.

**Make sure temperature of fluid in tank rises to 60 to 80°C (140 to 176°F).**

### WARNING:

**Warm up engine with shut-off valve fully opened. If engine is started with shut-off valve closed, fluid pressure in oil pump increases to maximum. This will raise oil temperature abnormally.**

3. Check pressure with steering wheel fully turned to left and right positions with engine idling at 1,000 rpm.

### CAUTION:

**Do not hold the steering wheel in a locked position for more than 15 seconds.**

**Oil pump maximum standard pressure:**

**(QG18DE)**

**7,649 - 8,238 kPa (78 - 84 kg/cm<sup>2</sup>, 1,109 - 1,194 psi)**

**(SR20DE)**

**8,140 - 8,728 kPa (83 - 89 kg/cm<sup>2</sup>, 1,180 - 1,266 psi)**

- If pressure reaches maximum operating pressure, system is OK.
  - If pressure increases above maximum operating pressure, check power steering pump flow control valve. Refer to "Components", ST-21 (QG18DE), ST-24 (SR20DE).
4. If power steering pressure is below the maximum operating pressure, slowly close shut-off valve and check pressure again.

### CAUTION:

**Do not close shut-off valve for more than 15 seconds.**

- If pressure increases to maximum operating pressure, gear is damaged. Refer to "Removal and Installation", ST-16.
  - If pressure remains below maximum operating pressure, pump is damaged. Refer to "Disassembly", ST-21 (QG18DE), ST-24 (SR20DE).
5. After checking hydraulic system, remove Tool and add fluid as necessary. Then completely bleed air out of system. Refer to "Bleeding Hydraulic System", ST-7.

# STEERING WHEEL AND STEERING COLUMN

Components

## Components

NIST0017

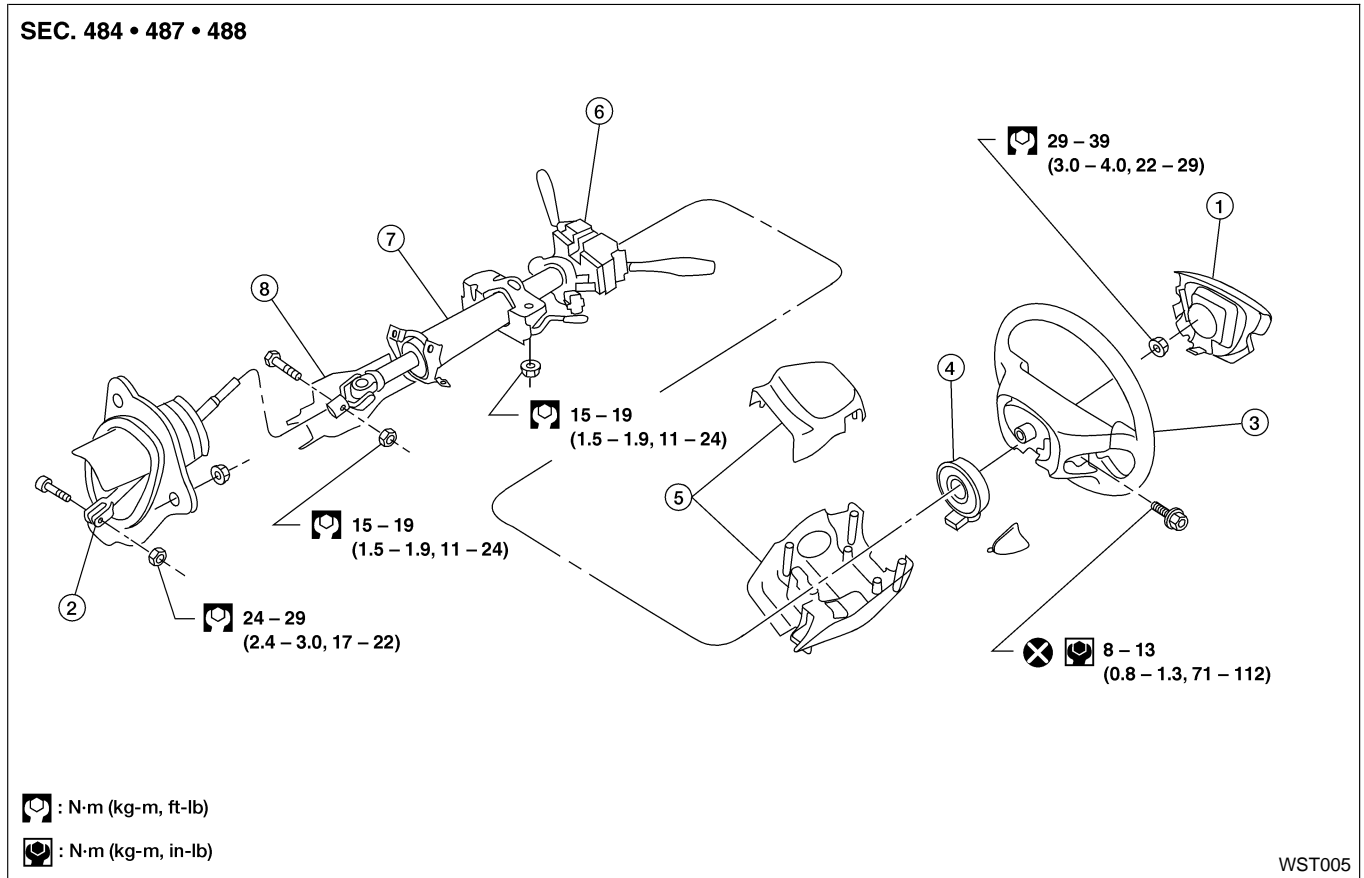

- |                   |                       |                                |
|-------------------|-----------------------|--------------------------------|
| 1. Air bag module | 4. Spiral cable       | 7. Steering column assembly    |
| 2. Lower joint    | 5. Column cover       | 8. Steering column lower cover |
| 3. Steering wheel | 6. Combination switch |                                |

### CAUTION:

- The rotation of the spiral cable (SRS "Air bag" component part) is limited. If the steering gear must be removed, set the front wheels in the straight-ahead direction. Do not rotate the steering column while the steering gear is removed.
- Remove the steering wheel before removing the steering lower joint to avoid damaging the SRS spiral cable.

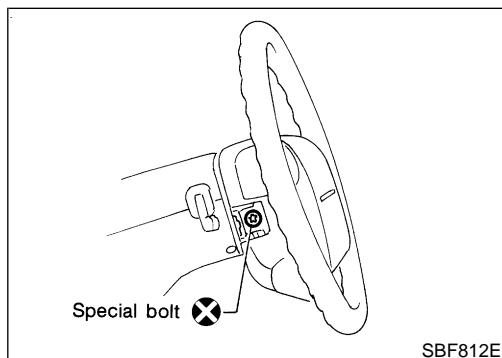

## Removal and Installation

### STEERING WHEEL

NIST0018

NIST0018S01

1. Remove air bag module.  
Refer to **RS-20**, "Removal — Driver Air Bag Module and Spiral Cable".

# STEERING WHEEL AND STEERING COLUMN

Removal and Installation (Cont'd)

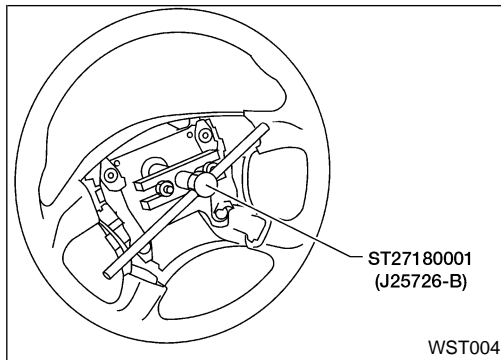

2. Remove steering wheel with Tool.
- For installation, refer to **RS-22**, "Installation — Driver Air Bag Module and Spiral Cable".

## STEERING COLUMN

### Removal

#### CAUTION:

- The rotation of the spiral cable (SRS "Air Bag" component part) is limited. If the steering gear must be removed, set the front wheels in the straight-ahead direction. Do not rotate the steering column while the steering gear is removed.
  - Remove the steering wheel before removing the steering lower joint to avoid damaging the SRS spiral cable. Refer to "Removal and Installation", ST-10.
1. Remove the steering wheel; refer to "Removal and Installation", ST-10.
  2. Remove instrument lower panel and dash lower reinforcement panel.
  3. Remove the column covers.
  4. Disconnect electrical connectors from the ignition switch and combination switch.
  5. Remove three screws securing combination switch and remove combination switch.

NIST0018S02

NIST0018S0201

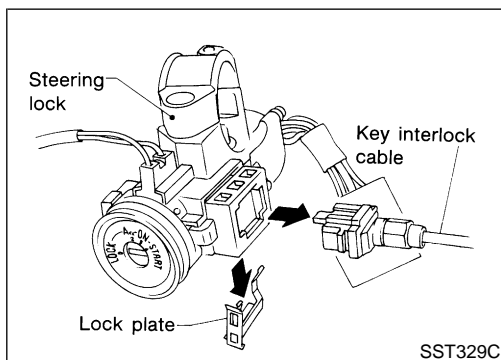

6. Remove key interlock cable (A/T models).
7. Remove the hole cover then remove bolt from lower joint.
8. Remove the steering column lower cover.
9. Remove four nuts securing steering column and remove steering column.

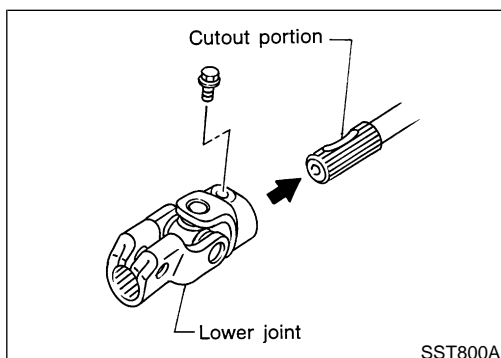

### Installation

- When installing steering column, fingertighten all lower bracket and clamp retaining bolts; then tighten them securely. Do not apply undue stress to steering column.
- When attaching coupling joint, be sure tightening bolt faces cutout portion.

NIST0018S0202

GI

MA

EM

LC

EC

FE

CL

MT

AT

AX

SU

BR

ST

RS

BT

HA

SC

EL

IDX

## STEERING WHEEL AND STEERING COLUMN

Removal and Installation (Cont'd)

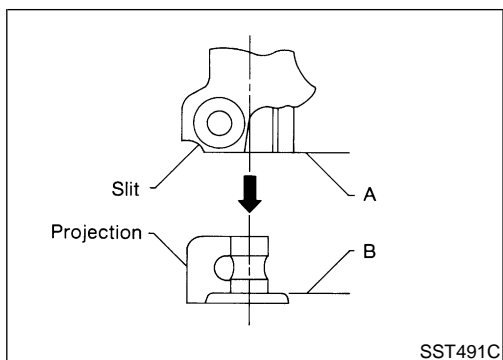

- Align slit of lower joint with projection on dust cover. Insert joint until surface A contacts surface B.

**CAUTION:**

After installation, turn steering wheel to make sure it moves smoothly. Ensure the number of turns are the same from the straight forward position to left and right locks. Be sure that the steering wheel is in a neutral position when driving straight ahead.

# STEERING WHEEL AND STEERING COLUMN

Disassembly and Assembly

## Disassembly and Assembly

=NIST0019

SEC. 484 • 488

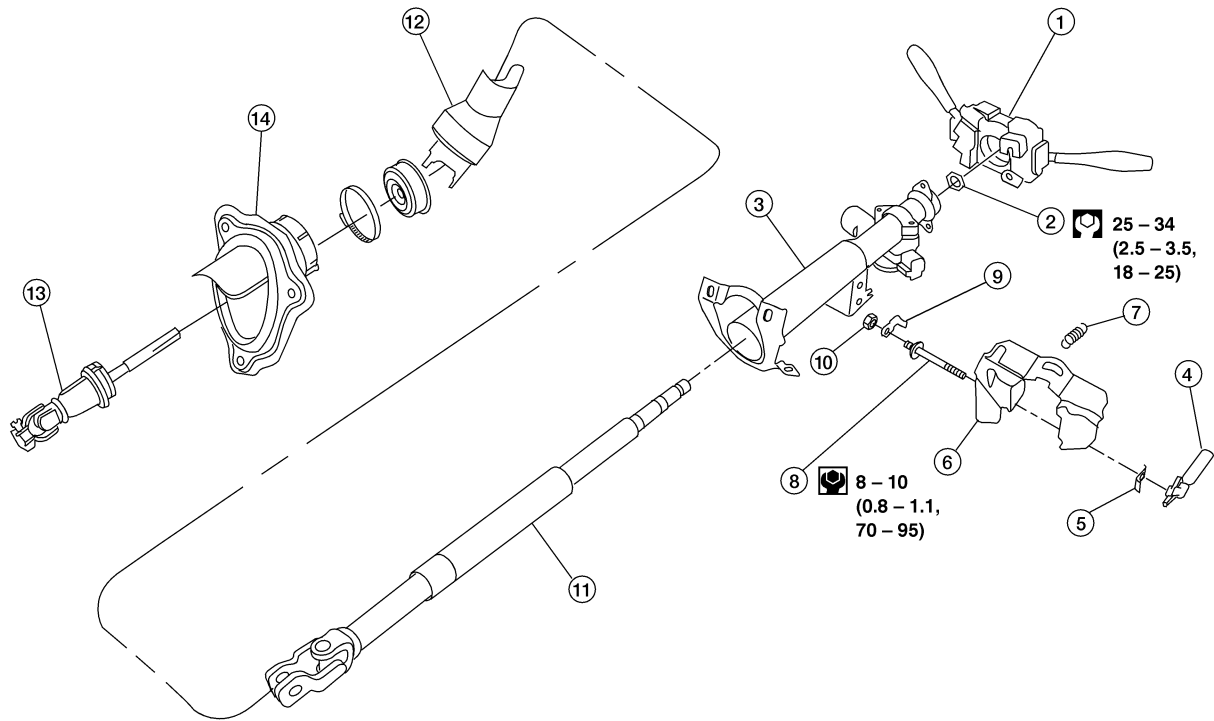

: N·m (kg·m, ft·lb)

: N·m (kg·m, in·lb)

WST006

- |                         |                                     |                                 |
|-------------------------|-------------------------------------|---------------------------------|
| 1. Combination switch   | 6. Steering column mounting bracket | 11. Column shaft assembly       |
| 2. Lock nut             | 7. Spring                           | 12. Steering column lower cover |
| 3. Jacket tube assembly | 8. Adjust bolt                      | 13. Lower joint                 |
| 4. Tilt lever           | 9. Adjust bolt stopper              | 14. Hole cover                  |
| 5. Tilt lever stopper   | 10. Nut                             |                                 |

GI  
MA  
EM  
LC  
EC  
FE  
CL  
MT  
AT  
AX

SU  
BR

ST

RS

BT

HA

SC

EL

IDX

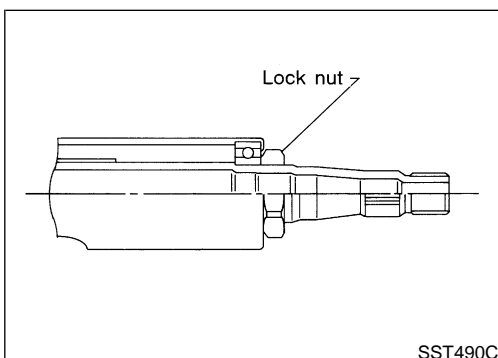

- When disassembling and assembling, unlock steering lock with key.
- Remove combination switch.
- Install lock nut on steering column shaft and tighten the nut.

# STEERING WHEEL AND STEERING COLUMN

Disassembly and Assembly (Cont'd)

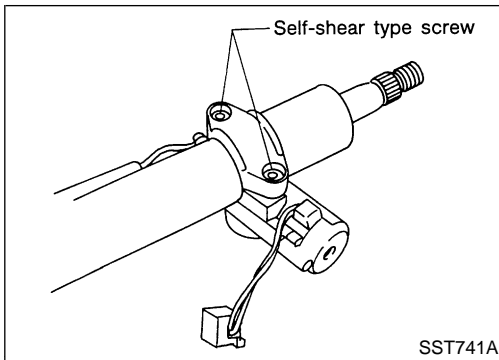

- Steering lock
- a) Break self-shear type screws using a drill or other appropriate tool.

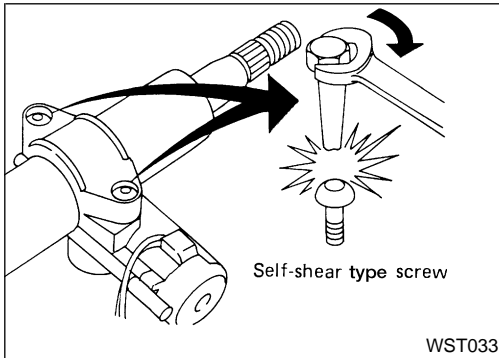

- b) Install new self-shear type screws, then tighten until screw heads break off.

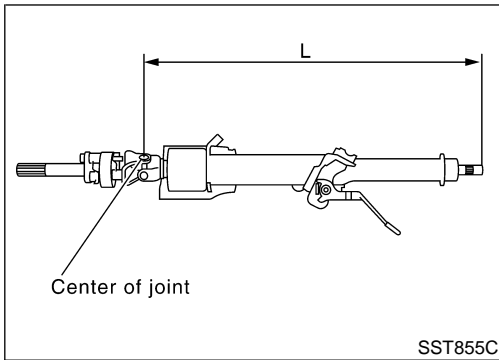

## Inspection

- When steering wheel does not turn smoothly, check the steering column as follows and replace damaged parts.
- a) Check column bearings for damage or unevenness. Lubricate with recommended multi-purpose grease or replace steering column as an assembly, if necessary.
- b) Check jacket tube for deformation or breakage. Replace if necessary.
- When the vehicle comes into a light collision, check length "L".

**Steering column length "L":**  
**542 - 544 mm (21.34 - 21.42 in)**

If out of the specifications, replace steering column as an assembly.

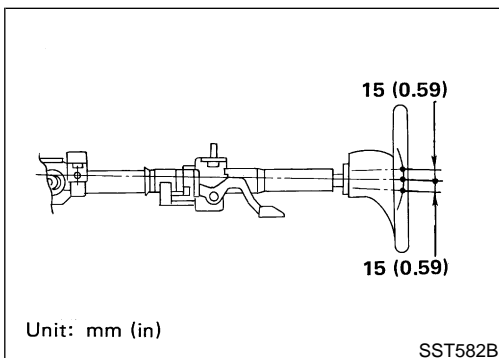

## TILT MECHANISM

- After installing steering column, check tilt mechanism operation.

# POWER STEERING GEAR AND LINKAGE

Components

## Components

NIST0021

SEC. 492

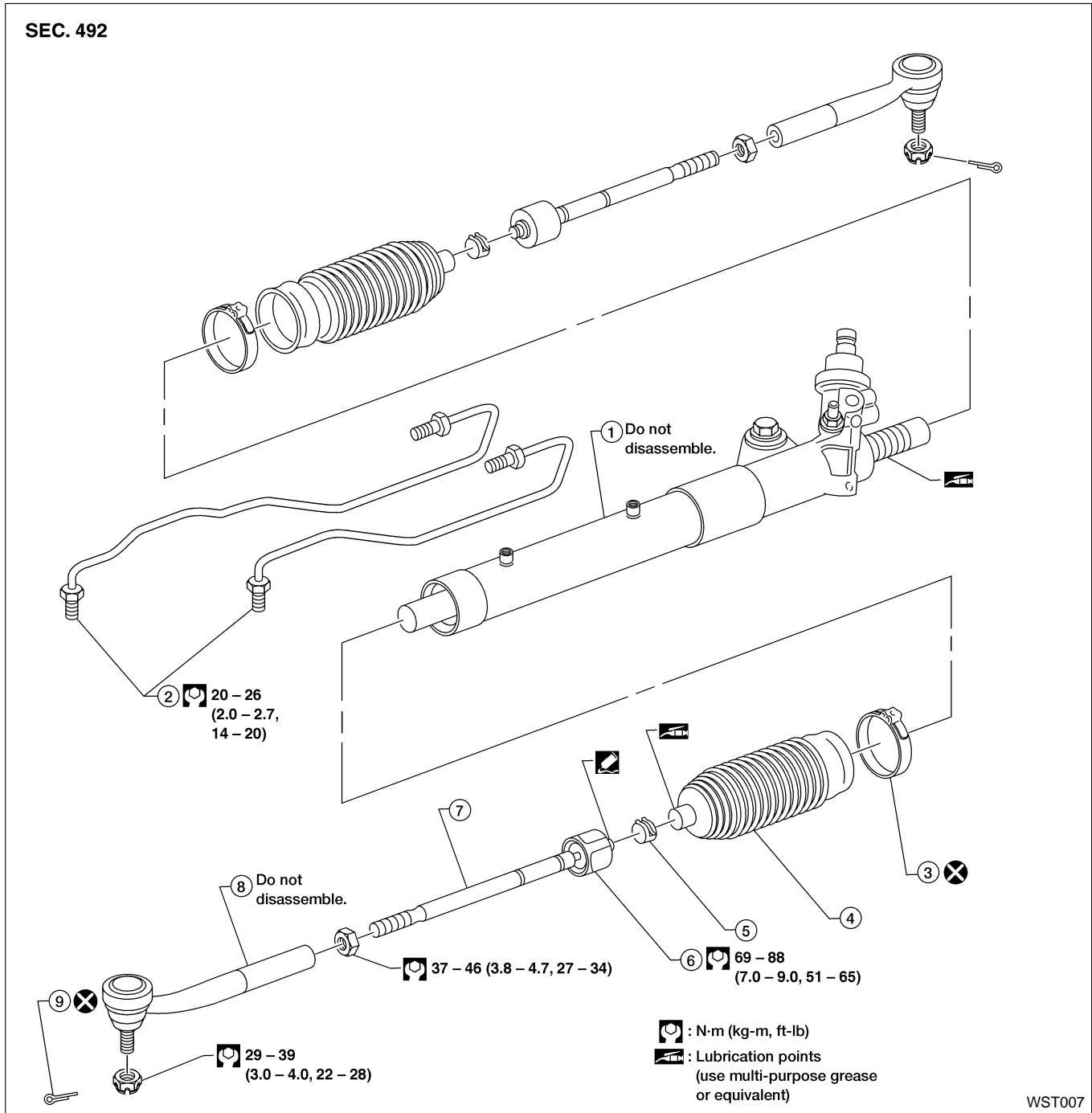

WST007

- |                      |                         |                         |
|----------------------|-------------------------|-------------------------|
| 1. Steering gear     | 4. Dust boot            | 7. Tie-rod              |
| 2. Gear housing tube | 5. Boot band            | 8. Tie-rod outer socket |
| 3. Boot clamp        | 6. Tie-rod inner socket | 9. Cotter pin           |

GI

MA

EM

LC

EC

FE

CL

MT

AT

AX

SU

BR

ST

RS

BT

HA

SC

EL

IDX

# POWER STEERING GEAR AND LINKAGE

Removal and Installation

## Removal and Installation

NIST0022

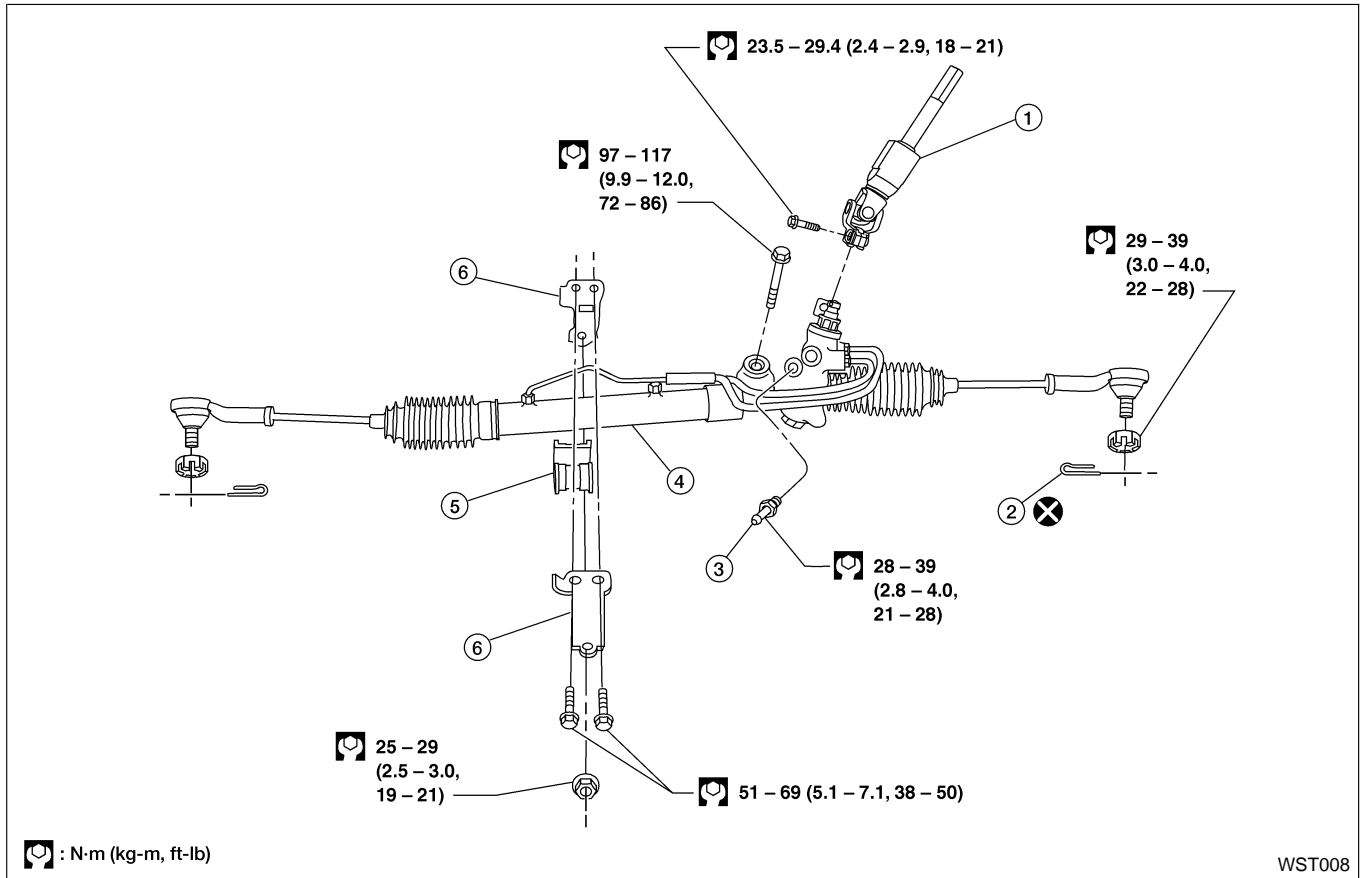

- |                |                              |                                  |
|----------------|------------------------------|----------------------------------|
| 1. Lower joint | 3. Low pressure line fitting | 5. Rack mounting insulator       |
| 2. Cotter pin  | 4. Gear and linkage assembly | 6. Gear housing mounting bracket |

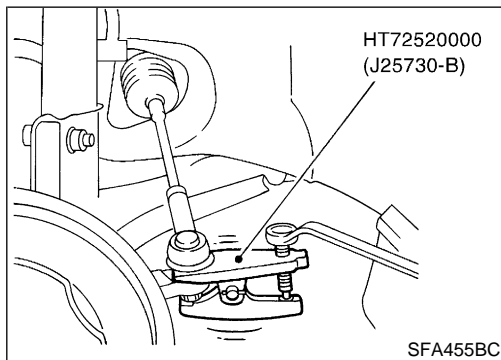

### CAUTION:

- The rotation of the spiral cable (SRS “Air bag” component part) is limited. If the steering gear must be removed, set the front wheels in the straight-ahead direction. Do not rotate the steering column while the steering gear is removed.
  - Remove the steering wheel before removing the steering lower joint to avoid damaging the SRS spiral cable.
1. Detach tie-rod outer sockets.
  2. Disconnect the power steering lines.
  3. Disconnect the steering gear lower joint.
  4. Position the bracket for the hoses and harness aside.
  5. Remove the return line fitting.



# POWER STEERING GEAR AND LINKAGE

Removal and Installation (Cont'd)

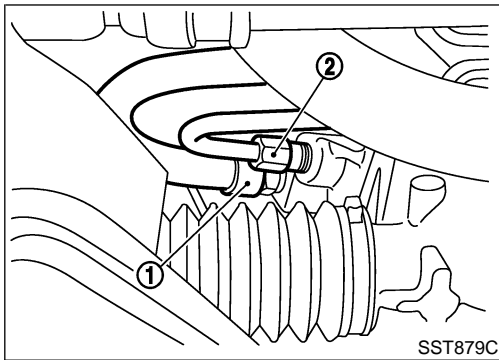
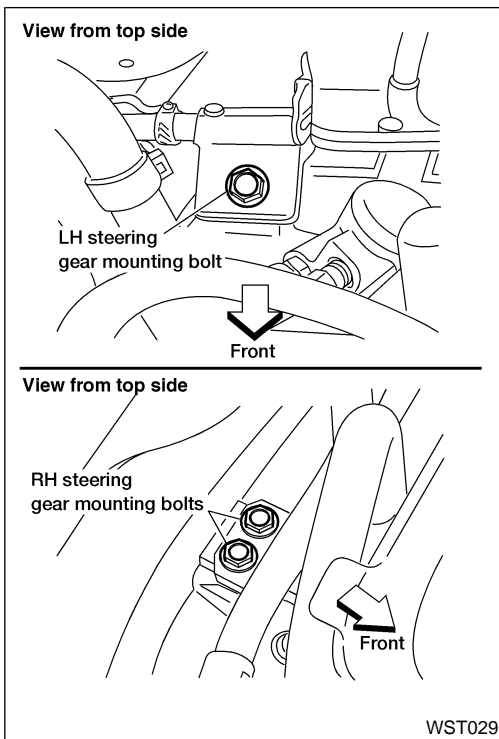

6. Remove the steering gear mounting bolts.
7. Remove the steering gear through the passenger side.

- Install power steering line connector.
- Observe specified tightening torque when tightening high-pressure and low-pressure line connectors. Excessive tightening will damage threads of connector or O-ring.

**Connector tightening torque:**

**1 Low-pressure side**

**28 - 39 N·m (2.8 - 4.0 kg·m, 21 - 28 ft·lb)**

**2 High-pressure side**

**15 - 25 N·m (1.5 - 2.5 kg·m, 11 - 18 ft·lb)**

- The O-ring in low-pressure pipe connector is larger than that in high-pressure connector. Take care to install the proper O-ring.

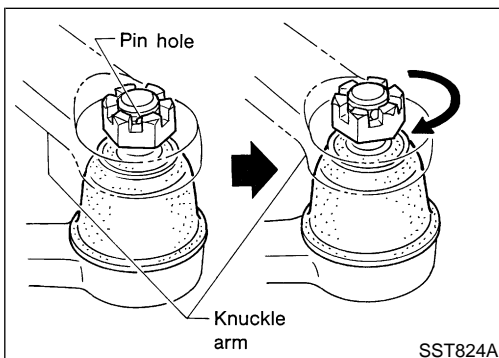

- Initially, tighten nut on tie-rod outer socket and knuckle arm to 29 to 39 N·m (3 to 4 kg·m, 22 to 28 ft·lb). Then tighten further to align nut groove with first pin hole so that cotter pin can be installed.

**CAUTION:**

**Tightening torque must not exceed 49 N·m (5 kg·m, 36 ft·lb).**

GI  
MA  
EM  
LC  
EC  
FE  
CL  
MT  
AT  
AX  
SU  
BR  
ST  
RS  
BT  
HA  
SC  
EL  
IDX

# POWER STEERING GEAR AND LINKAGE

## Removal and Installation (Cont'd)

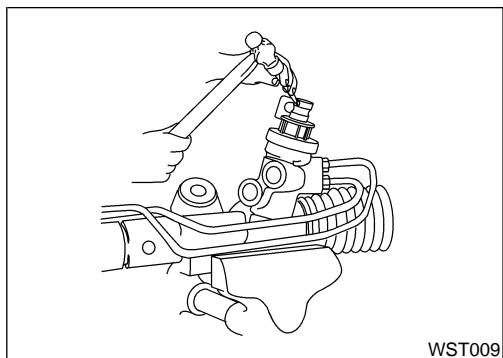

- Before removing lower joint from gear, set gear in neutral (wheels in straight-ahead position). After removing lower joint, put matching mark on pinion shaft and pinion housing to record neutral position.
- To install, set left and right dust boots to equal deflection. Attach lower joint by aligning matching marks of pinion shaft and pinion housing.

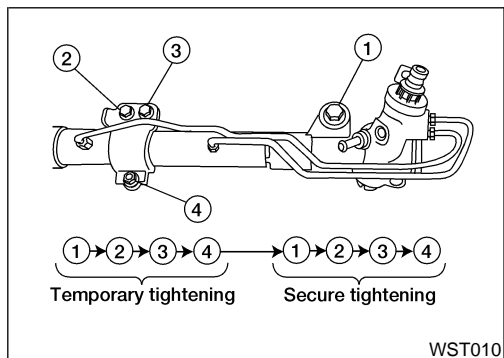

- Tighten gear housing mounting bracket bolts and nut in the order shown.

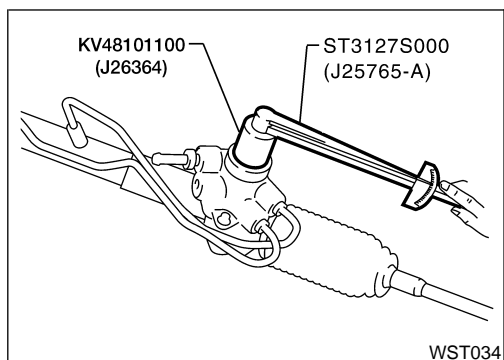

## Disassembly

1. Prior to disassembling, measure pinion rotating torque. NIST0023

**Within  $\pm 100^\circ$  from the neutral position:**

**Average rotating torque**

**0.3 - 1.3 N-m (3 - 13 kg-cm, 2.6 - 11.3 in-lb)**

**Maximum torque deviation**

**0.6 N-m (6 kg-cm, 5.2 in-lb)**

**Except for above measuring range:**

**Maximum rotating torque**

**1.9 N-m (19 kg-cm, 16 in-lb)**

**Maximum force deviation**

**0.6 N-m (6 kg-cm, 5.2 in-lb)**

- If pinion rotating torque is not within the specifications, replace steering gear assembly.
  - Before measuring, disconnect gear housing tube and drain fluid.
  - Use soft jaws when holding steering gear housing. Handle gear housing carefully, as it is made of aluminum. Do not grip cylinder in a vise.
2. Remove tie-rod outer sockets and boots.
  3. Remove tie-rod inner sockets.

## Inspection

Thoroughly clean all parts in cleaning solvent or Genuine NISSAN PSF II or equivalent. Blow dry with compressed air, if available. NIST0024

## BOOT

- Check condition of boot. If cracked excessively, replace it. NIST0024S01
- Check boots for accumulation of power steering fluid.

# POWER STEERING GEAR AND LINKAGE

Inspection (Cont'd)

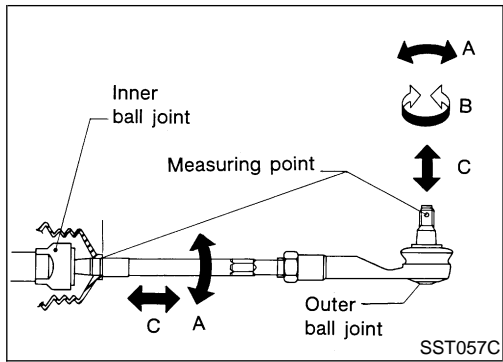

## TIE-ROD OUTER AND INNER SOCKETS

- Check outer and inner ball joints for swinging force "A" and axial end play "C".  
**Refer to "Steering Gear and Linkage", ST-29.**
- Check outer ball joint for rotating torque "B".  
**Refer to "Steering Gear and Linkage", ST-29.**
- Check condition of dust cover. If excessively cracked, replace outer tie-rod.

## Assembly

1. Install tie-rod inner sockets, dust boots and outer sockets.  
**Apply locking sealant to inner socket threads.**

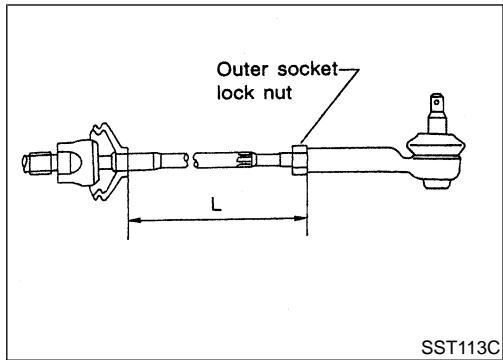

2. Tighten outer socket lock nut.

**Tie-rod length "L":**

**Refer to "Steering Gear and Linkage", ST-29.**

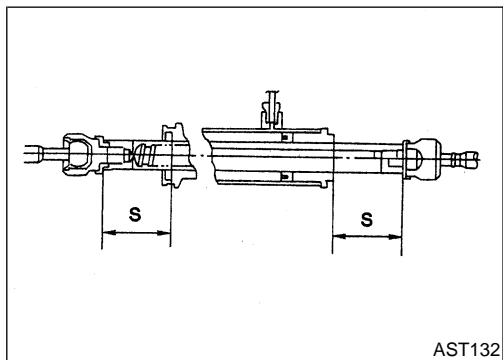

3. Measure rack stroke.

**Rack stroke "S":**

**Refer to "Steering Gear and Linkage", ST-29.**

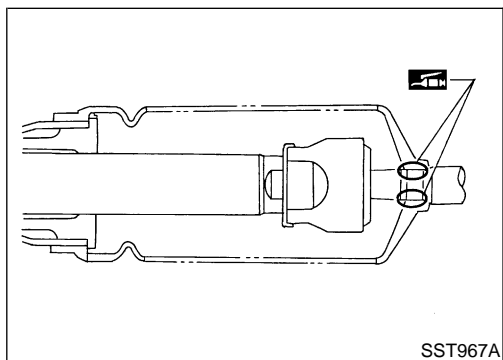

4. Before installing boot, coat the contact surfaces between boot and tie-rod with grease.

GI

MA

EM

LC

EC

FE

CL

MT

AT

AX

SU

BR

ST

RS

BT

HA

SC

EL

IDX

## POWER STEERING GEAR AND LINKAGE

Assembly (Cont'd)

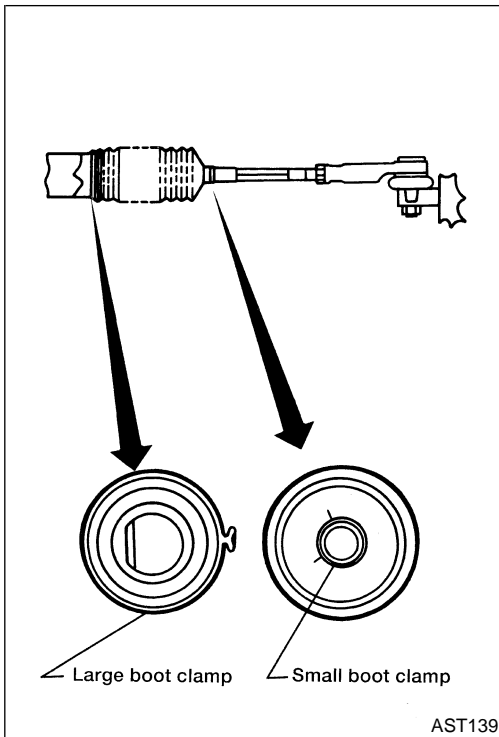

5. Install boot clamps.
  - Install large boot clamp using suitable tool and crimp securely.
  - Install small boot clamp as shown.

# POWER STEERING OIL PUMP

QG18DE

## QG18DE COMPONENTS

NIST0027

NIST0027S01

GI

MA

EM

LC

EC

FE

CL

MT

AT

AX

SU

BR

ST

RS

BT

HA

SC

EL

IDX

SEC. 490•493  
Model No. F40

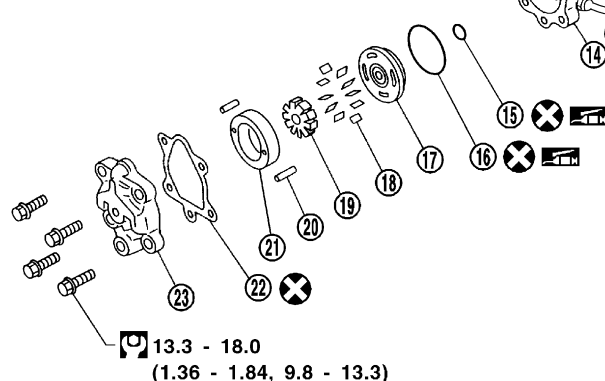
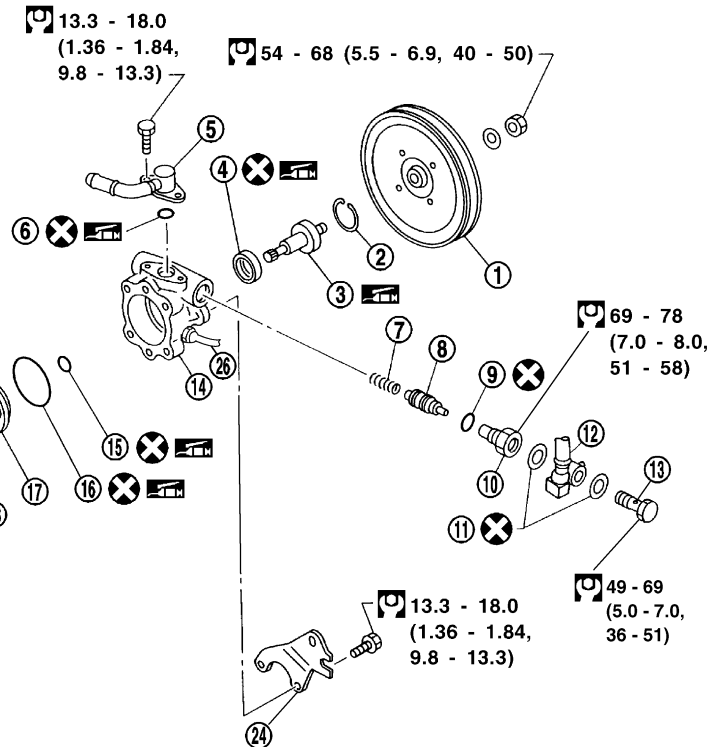
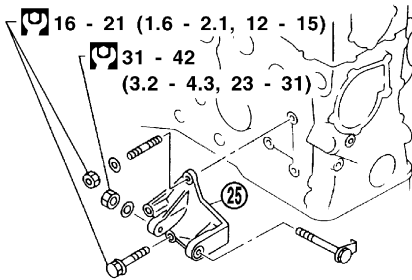

: N·m (kg·m, ft·lb)  
 : Lubrication points  
(With Genuine NISSAN PSF II)

WST021

- |                       |                      |                                    |
|-----------------------|----------------------|------------------------------------|
| 1. Pulley             | 10. Connector        | 19. Rotor                          |
| 2. Snap ring          | 11. Washer           | 20. Pin                            |
| 3. Drive shaft        | 12. Joint            | 21. Cam ring                       |
| 4. Oil seal           | 13. Connector bolt   | 22. Gasket                         |
| 5. Suction pipe       | 14. Pump case        | 23. Rear cover                     |
| 6. O-ring             | 15. O-ring           | 24. Mounting bracket               |
| 7. Spring             | 16. O-ring           | 25. Power steering pump bracket    |
| 8. Flow control valve | 17. Front side plate | 26. Power steering pressure switch |
| 9. O-ring             | 18. Vane             |                                    |

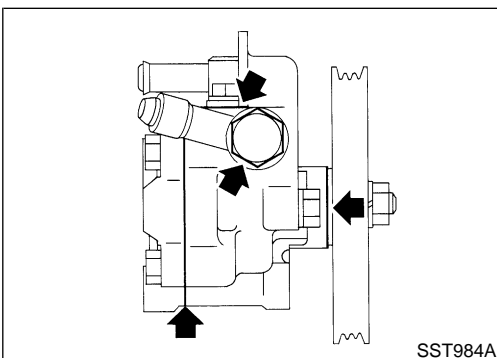

### PRE-DISASSEMBLY INSPECTION

NIST0027S02

Disassemble the power steering oil pump only if the following items are found.

- Fluid leak from any point shown in the figure.
- Deformed or damaged pulley
- Poor performance

### DISASSEMBLY

NIST0027S03

#### CAUTION:

- Parts which can be disassembled are strictly limited. Never disassemble parts other than those specified.

# POWER STEERING OIL PUMP

QG18DE (Cont'd)

- Disassemble in as clean a place as possible.
- Clean your hands before disassembly.
- Do not use rags; use nylon cloths or paper towels.
- Refer to "Precautions for Steering System", ST-2.
- When disassembling and reassembling, do not let foreign matter enter or contact the parts.

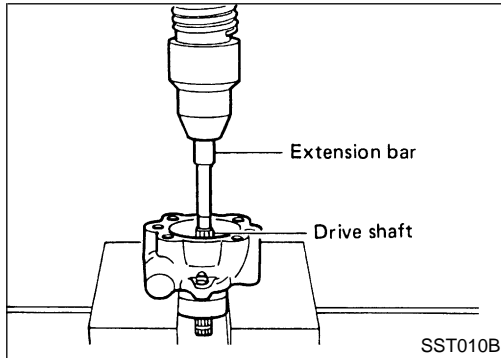

- Remove snap ring, then draw drive shaft out.  
**Be careful not to drop drive shaft.**

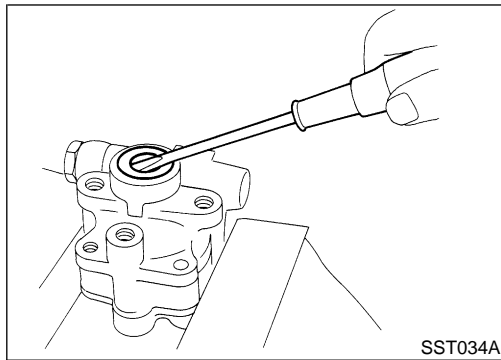

- Remove oil seal.  
**Be careful not to damage front housing.**

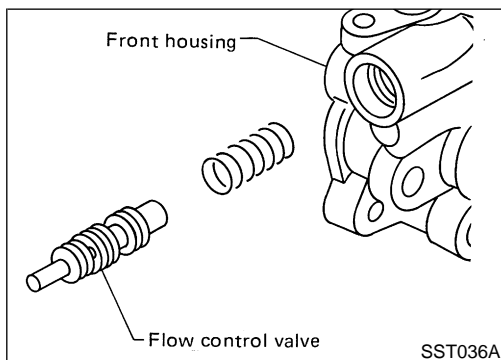

- Remove connector and flow control valve with spring.  
**Be careful not to drop flow control valve.**  
**Do not disassemble flow control valve.**

## INSPECTION

NIST0027S04

- If pulley is cracked or deformed, replace it.
- If an oil leak is found around pulley shaft oil seal, replace the seal.
- If serration on pulley or pulley shaft is deformed or worn, replace it.

## ASSEMBLY

NIST0027S05

Assemble oil pump, noting the following instructions.

- Make sure O-rings and oil seal are properly installed.
- Always install new O-rings and oil seal.
- Be careful of oil seal direction.
- Cam ring, rotor and vanes must be replaced as a set if necessary.
- Coat each part with Genuine NISSAN PSF II or equivalent when assembling.

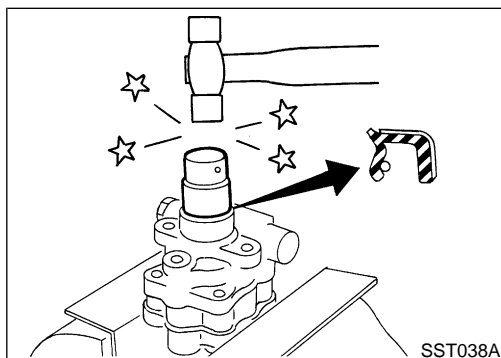

# POWER STEERING OIL PUMP

QG18DE (Cont'd)

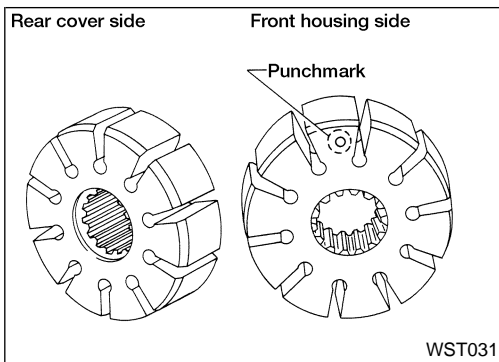

- Pay attention to the direction of rotor.

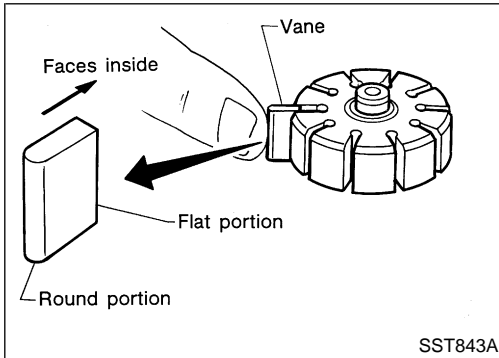

- When assembling vanes to rotor, flat surfaces of vanes must face inside of rotor (rounded surfaces of vanes face cam ring side).

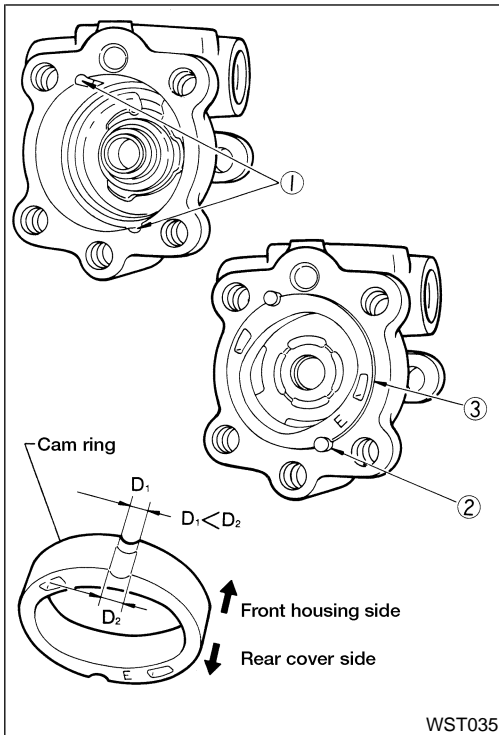

- Insert pin 2 into pin groove 1 of front housing and front side plate. Then install cam ring 3 as shown at left.

**Cam ring:**

**$D_1$  is less than  $D_2$ .**

GI

MA

EM

LC

EC

FE

CL

MT

AT

AX

SU

BR

**ST**

RS

BT

HA

SC

EL

IDX

# POWER STEERING OIL PUMP

SR20DE

## SR20DE COMPONENTS

NIST0028

NIST0028S01

SEC. 490•493  
Model No. CP1

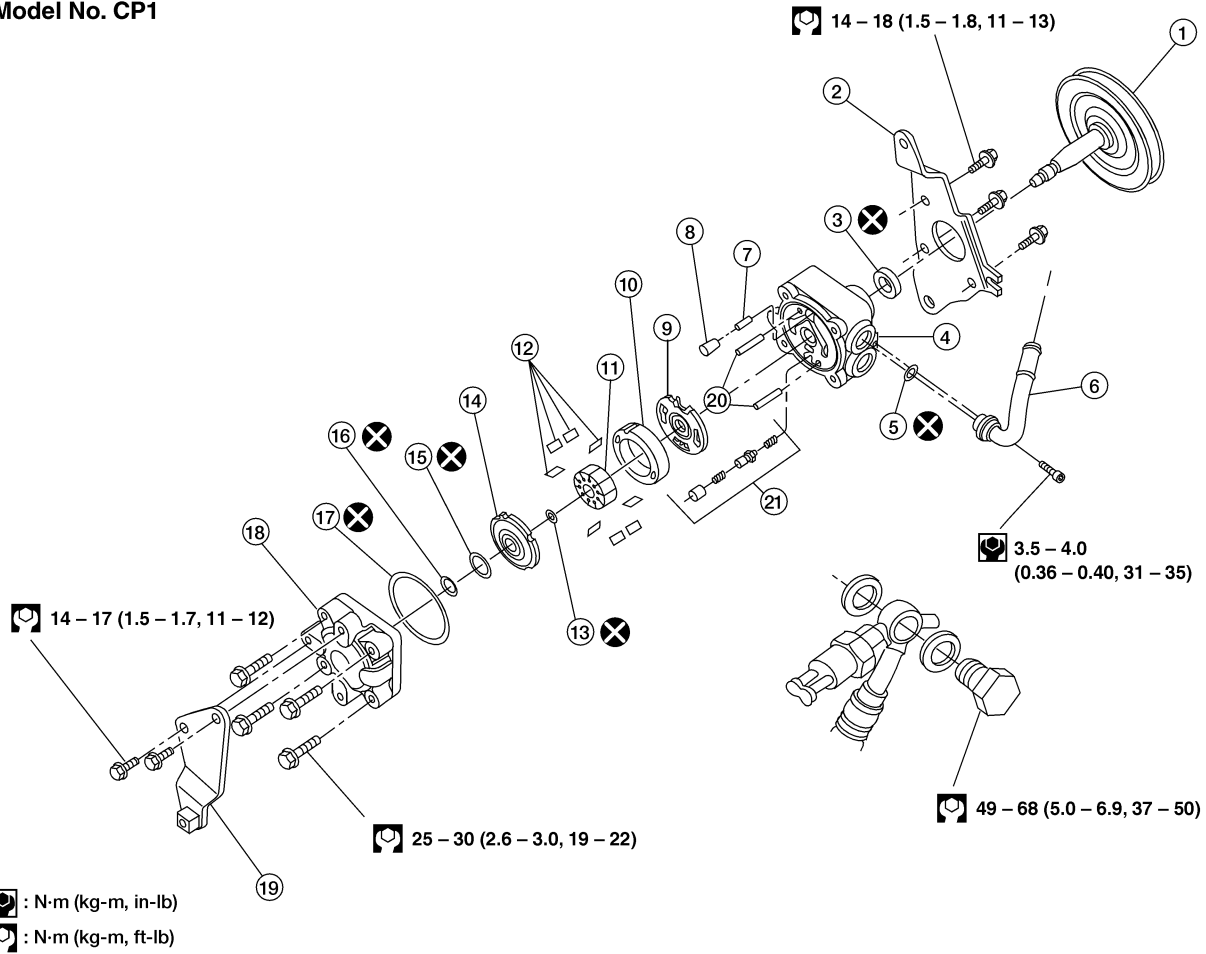

WST003

- |                  |                     |                                     |
|------------------|---------------------|-------------------------------------|
| 1. Pulley        | 8. Spool            | 15. O-ring                          |
| 2. Front bracket | 9. Front side plate | 16. Back-up ring                    |
| 3. O-ring        | 10. Cam ring        | 17. O-ring                          |
| 4. Front housing | 11. Rotor           | 18. Rear cover                      |
| 5. Oil seal      | 12. Vanes           | 19. Rear bracket                    |
| 6. Suction pipe  | 13. Snap ring       | 20. Pins                            |
| 7. Spring        | 14. Rear side plate | 21. Flow control valve sub-assembly |

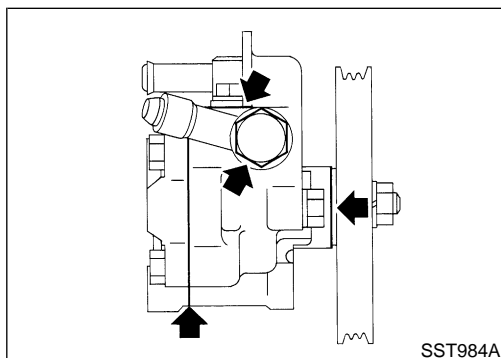

### PRE-DISASSEMBLY INSPECTION

NIST0028S02

Disassemble the power steering oil pump only if the following items are found.

- Oil leak from any point shown in the figure
- Deformed or damaged pulley
- Poor performance

### DISASSEMBLY

NIST0028S03

1. Fit the power steering pump to a vise. (Use soft jaw in vise to protect power steering pump case from damage.)
2. Remove two mounting bolts from rear cover and remove rear



# POWER STEERING OIL PUMP

SR20DE (Cont'd)

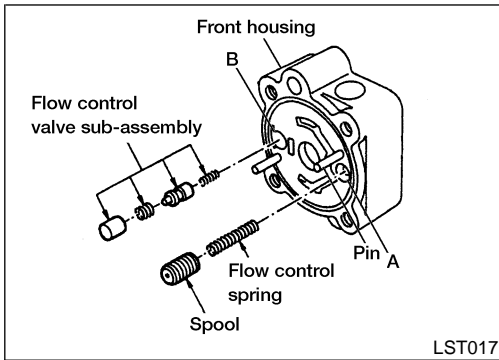
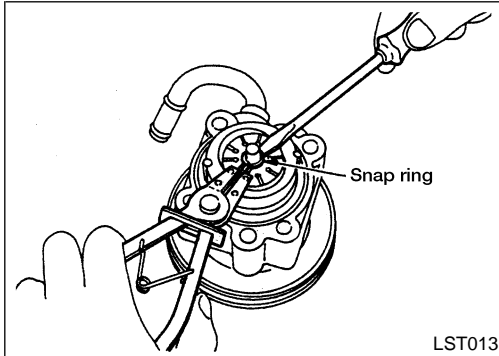

- bracket.  
Rear bracket may be different in shape depending on vehicle.
3. Remove three mounting bolts from front housing and remove front bracket.  
Front bracket may be different in shape depending on vehicle.
  4. Remove four rear cover mounting bolts, then remove rear cover and rear side plate.
  5. Remove O-ring from front housing.
  6. Remove rear side plate.
  7. Remove inner and outer seals from side plate.
  8. Spread snap ring with pliers and remove it from drive shaft groove with a screwdriver.

## NOTE:

Be careful not to damage rotor and cam ring. If damage is found, replace rotor, cam ring and vanes as a set. Damaged parts can cause malfunctions.

9. Remove drive shaft assembly from front housing.

## NOTE:

Be careful not to damage the shaft. If damage is found, replace drive shaft assembly.

10. Remove cam ring, rotor, vanes and front side plate, then spool, flow control spring and flow control valve sub-assembly from holes A and B.

Be careful not to drop or deform spool and flow control valve sub-assembly.

## NOTE:

Do not let dirt contact spool and flow control valve sub-assembly. If dirt is found, rinse the parts with Genuine NISSAN PSF II or equivalent.

11. Remove suction pipe bolt from front housing, then suction pipe and O-ring seal.
12. Wrap a flat bladed screwdriver with tape and carefully remove oil seal.

## NOTE:

Be careful not to damage the inside surfaces of front housing. If damage is found, replace pump assembly.

## INSPECTION

- Inspect the inside surfaces of front housing and rear cover for damage. If damage is found, replace rear cover. If damage is found in front housing, replace power steering pump assembly. NIST0028S04
- Inspect cam ring for damage. If damage is found, replace rotor, cam ring and vanes as a set. HA
- Inspect front side plate and rear side plate for damage. If damage is found, replace front side plate and rear side plate as a set. SC

## ASSEMBLY

### NOTE:

Always install new O-ring, oil seal and snap ring. Coat each part with Genuine NISSAN PSF II or equivalent when assembling. NIST0028S05

GI  
MA  
EM  
LC  
EC  
FE  
CL  
MT  
AT  
AX  
SU  
BR  
ST  
RS  
BT  
HA  
SC  
EL  
IDX

# POWER STEERING OIL PUMP

SR20DE (Cont'd)

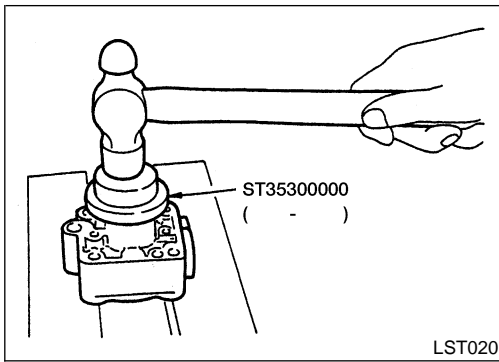

LST020

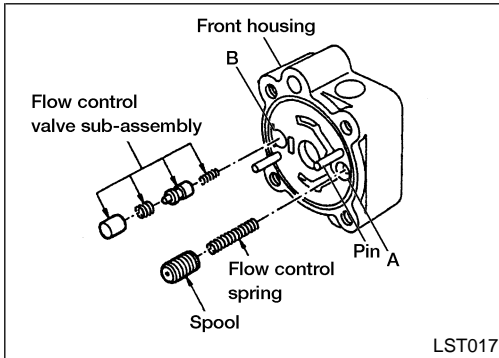

LST017

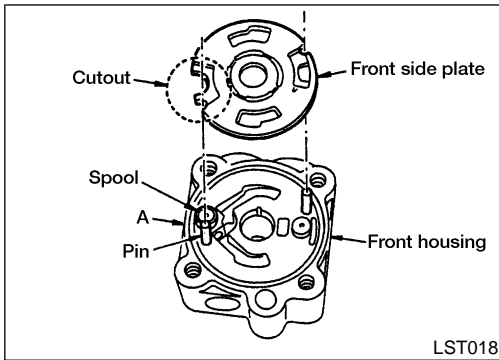

LST018

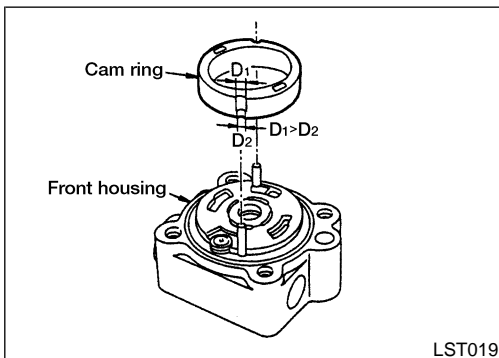

LST019

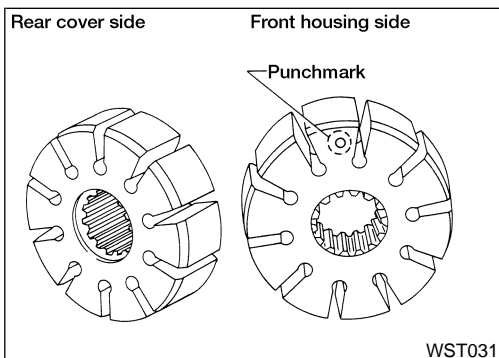

WST031

1. Install oil seal in front housing by striking lightly with a hammer and a drift.
2. After assembling, apply a slight amount of NISSAN MP Special Grease No. 2 or equivalent to the lip of the oil seal and ensure that spring has been properly set.
3. Insert pin into front housing. If difficult, strike pin lightly into front housing with a taped hammer.
4. Insert valve sub-assembly into the hole B of front housing.
5. Insert flow control (F/C) spring and spool into hole A of front housing.
6. Insert front side plate so that pin groove aligns with pin in front housing. Locate the cutout in front side plate to face hole A of front housing when inserting.
7. Insert cam ring so that the cam ring pin groove aligns with the front housing pin. Install cam ring so that smaller pin groove in cam ring ( $D_2$ ) faces front side plate. Pay attention to the direction of cam ring. Otherwise, pump will malfunction.  
**Cam ring:  $D_2$  is less than  $D_1$ .**
8. Install rotor so that minor chamfer of rotor's hole spline or punchmark on rotor's surface faces front side plate and major chamfer faces rear cover.

# POWER STEERING OIL PUMP

SR20DE (Cont'd)

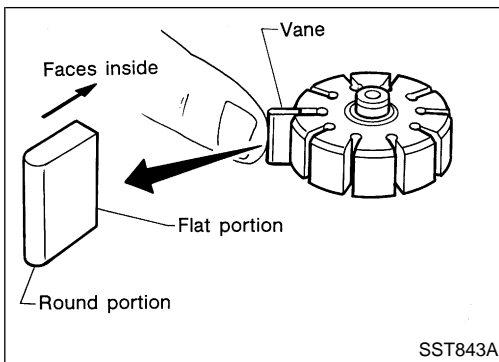

SST843A

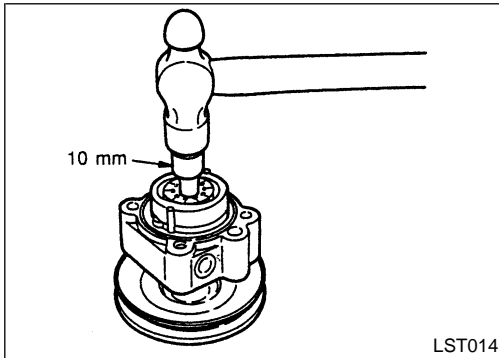

LST014

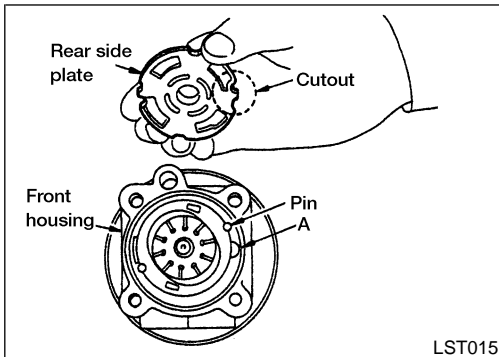

LST015

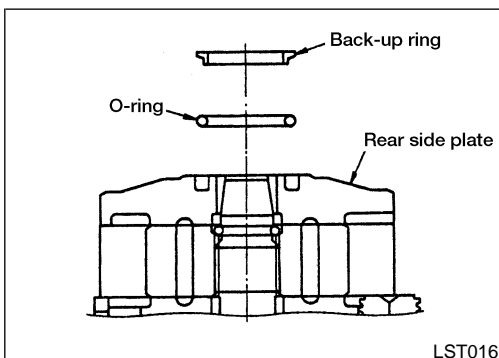

LST016

9. When assembling vanes to rotor, flat surfaces of vanes must face inside of rotor (rounded surfaces of vanes face cam ring side).
10. Install drive shaft assembly into front housing. Be careful not to damage oil seal and the inside surfaces of front housing with spline gear.
11. Install new snap ring into groove at end of drive shaft assembly, using a hammer and drift. Be careful not to damage rotor. If damage is found, replace power steering pump assembly.
1. After pulling drive shaft assembly toward front housing, insert rear side plate so that rear side plate pin groove aligns with the front housing pin. Position rear side plate cutout to face hole A of front housing when installing. After assembling, make sure spool and cutout are located on the side of front housing hole A.
2. Coat new rear cover O-ring with Genuine NISSAN PSF II or equivalent and install to rear side plate. Then install rear side plate inner seal, then outer seal. Coat new seals with Genuine NISSAN PSF II or equivalent and install to front housing.
3. Secure power steering pump in a vise. (Use soft jaw in vise to protect power steering pump case from damage.)
4. Install rear cover and tighten four mounting bolts to a torque of 25 - 30 N·m (2.6 - 3.0 kg·m, 19 - 22 ft·lb) in diagonal sequence.
5. Install front bracket and tighten the mounting bolt to a torque of 14 - 17 N·m (1.5 - 1.7 kg·m, 11 - 12 ft·lb).
6. Install rear bracket and tighten the mounting bolt to a torque of 14 - 18 N·m (1.5 - 1.8 kg·m, 11 - 13 ft·lb).
7. Coat new O-ring with Genuine NISSAN PSF II or equivalent and insert to the groove of suction pipe. Install suction pipe to front housing and tighten the mounting bolt to a torque of 3.5 - 4.0 N·m (0.36 - 0.40 kg·m, 31 - 35 in·lb).

GI  
MA  
EM  
LC  
EC  
FE  
CL  
MT  
AT  
AX  
SU  
BR  
ST  
RS  
BT  
HA  
SC  
EL  
IDX

# SERVICE DATA AND SPECIFICATIONS (SDS)

## General Specifications

### General Specifications

NIST0032

Steering model	Power steering
Steering gear type	PR25T
Steering overall gear ratio	16.6
Turns of steering wheel (Lock to lock)	2.9
Steering column type	Collapsible, tilt

### Steering Wheel

NIST0033

Steering wheel axial play mm (in)	0 (0)
Steering wheel play mm (in)	35 (1.38) or less
Movement of gear housing mm (in)	$\pm 2$ ( $\pm 0.08$ ) or less

### Steering Column

NIST0034

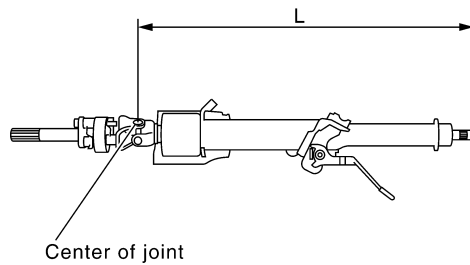

SST855C

Applied model	All
Steering column length "L" mm (in)	542 - 544 (21.34 - 21.42)

# SERVICE DATA AND SPECIFICATIONS (SDS)

Steering Gear and Linkage

## Steering Gear and Linkage

NIST0035

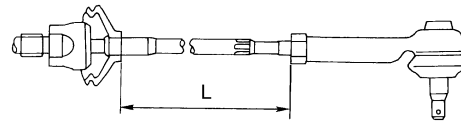

SST867C

Applied model	All	
Steering gear type	PR25T	
Tie-rod outer ball joint	Swinging force at cotter pin hole: "A" N (kg, lb)	6.9 - 65.7 (0.66 - 6.59, 1.5 - 14.8)
	Rotating torque: "B" N-m (kg-cm, in-lb)	0.29 - 2.94 (3.0 - 30.0, 2.6 - 26.0)
	Axial end play: "C" mm (in)	0.4 (0.016) or less
Tie-rod inner ball joint	Swinging force*: "A" N (kg, lb)	5.9 - 46.1 (0.58 - 4.65, 1.3 - 10.4)
	Axial end play: "C" mm (in)	0.2 (0.004) or less
Tie-rod standard length "L" mm (in)	193.2 (7.606)	

\*: Measuring point [ $l$ : 172 mm (6.77 in)]

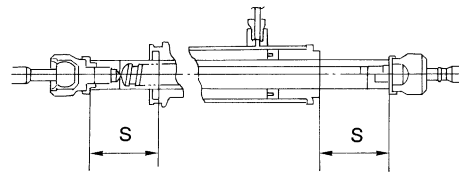

SST086BA

Retainer adjustment Adjusting screw	Initial tightening torque N-m (kg-cm, in-lb)	4.9 - 5.9 (50 - 60, 43 - 52)
	Retightening torque after loosening N-m (kg-cm, in-lb)	0.2 (2, 1.7)
	Tightening torque after gear has settled N-m (kg-cm, in-lb)	4.9 - 5.9 (50 - 60, 43 - 52)
	Returning angle degree	60° - 80°
Steering gear type	PR25T	
Rack stroke "S" mm (in)	65 (2.56)	
Pinion gear preload without gear fluid Within $\pm 100^\circ$ from the neutral position	Average rotating torque N-m (kg-cm, in-lb)	0.3 - 1.3 (3 - 13, 2.6 - 11.3)
	Maximum torque deviation N-m (kg-cm, in-lb)	0.6 (6, 5.2)
Except above range	Maximum rotating torque N-m (kg-cm, in-lb)	1.9 (19, 16)
	Maximum torque deviation N-m (kg-cm, in-lb)	0.6 (6, 5.2)

# SERVICE DATA AND SPECIFICATIONS (SDS)

Power Steering

## Power Steering

NIST0036

Applied model		QG18DE	SR20DE
Steering gear type		PR25T	
Pump type		F40	CP1
Rack sliding force N (kg, lb) Under normal operating oil pressure	Range within $\pm 11.5$ mm ( $\pm 0.453$ in) from the neutral position at rack speed of 3.5 mm (0.138 in)/s	Average force	216 - 284 (22 - 29, 49 - 64)
		Maximum force deviation	98 (10, 22)
	Except for the above range	Maximum sliding force	294 (30, 66)
		Maximum force deviation	147 (15, 33)
Steering wheel turning force (Measured at one full turn from the neutral position) N (kg, lb)		39 (4, 9) or less	
Fluid capacity (Approximate) ℓ (US qt, Imp qt)		1.0 (1-1/8, 7/8)	
Oil pump maximum pressure kPa (kg/cm <sup>2</sup> , psi)		7,649 - 8,238 (78 - 84, 1,109 - 1,194)	8,140 - 8,728 (83 - 89, 1,180 - 1,266)