

CLUTCH

SECTION **CL**

CONTENTS

PRECAUTIONS	2	Assembly	12
Precautions	2	Installation	12
PREPARATION	3	PIPING	13
Special Service Tools	3	Removal	13
Commercial Service Tools	3	Installation	13
NOISE, VIBRATION AND HARSHNESS (NVH)		CLUTCH RELEASE MECHANISM	14
TROUBLESHOOTING	4	Components	14
NVH Troubleshooting Chart	4	Removal	14
CLUTCH SYSTEM	5	Inspection	14
Components	5	Installation	14
Inspection and Adjustment	6	CLUTCH DISC, CLUTCH COVER AND	
ADJUSTING CLUTCH PEDAL	6	FLYWHEEL	17
BLEEDING PROCEDURE	7	Components	17
CLUTCH MASTER CYLINDER	8	Inspection and Adjustment	17
Components	8	CLUTCH DISC	17
Removal	8	CLUTCH COVER AND FLYWHEEL	18
Installation	9	FLYWHEEL INSPECTION	18
Disassembly	9	Installation	18
Inspection	9	SERVICE DATA AND SPECIFICATIONS (SDS)	19
Assembly	9	Clutch Control System	19
OPERATING CYLINDER	11	Clutch Master Cylinder	19
Components	11	Clutch Operating Cylinder	19
Removal	11	Clutch Disc	19
Disassembly	11	Clutch Cover	19
Inspection	12	Clutch Pedal	19

GI
MA
EM
LC
EC
FE
CL
MT
AT
AX
SU
BR
ST
RS
BT
HA
SC
EL
IDX

PRECAUTIONS

Precautions

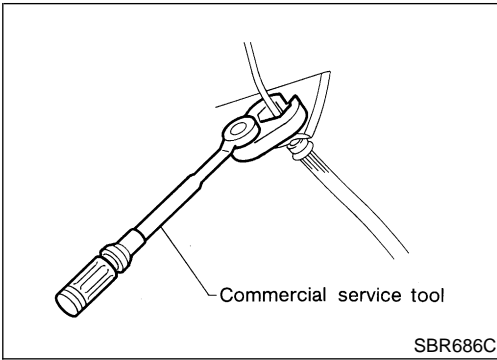

Precautions

NICL0001

- Recommended fluid is brake fluid "DOT 3".
- Do not reuse drained brake fluid.
- Be careful not to splash brake fluid on painted areas; it may cause paint damage. If brake fluid is splashed on painted areas, wash it away with water immediately.
- Use flare nut wrench when removing or installing clutch hydraulic tubes.
- Use new brake fluid to clean or wash all parts of master cylinder and operating cylinder.
- Never use mineral oils such as gasoline or kerosene. It will ruin the rubber parts of the hydraulic system.

WARNING:

After cleaning clutch disc, wipe it with a dust collector. Do not use compressed air.

PREPARATION

Special Service Tools

Special Service Tools

NICL0002

The actual shapes of Kent-Moore tools may differ from those of special service tools illustrated here.

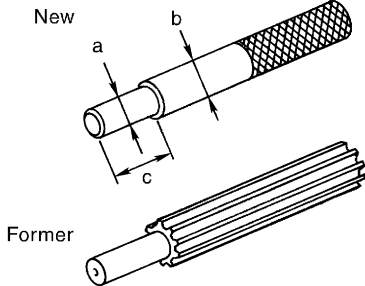
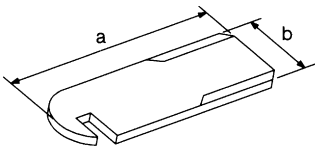
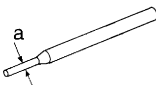
Tool number (Kent-Moore No.) Tool name	Description	
KV30101600 (New) KV30101000 (Former) (J33213) Clutch aligning bar	 <p>New</p> <p>Former</p> <p>NT641</p>	Installing clutch cover and clutch disc a: 15.9 mm (0.626 in) dia. b: 17.9 mm (0.705 in) dia. c: 40 mm (1.57 in)
ST20050240 (—) Diaphragm spring adjusting wrench	 <p>NT404</p>	Adjusting unevenness of diaphragm spring of clutch cover a: 150 mm (5.91 in) b: 25 mm (0.98 in)
KV32101000 (J25689-A) Pin punch	 <p>NT410</p>	Removing and installing spring pin a: 4 mm (0.16 in) dia.

Commercial Service Tools

NICL0003

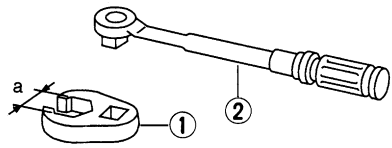
Tool name	Description	
1 Flare nut crowfoot 2 Torque wrench	 <p>NT360</p>	Removing and installing clutch piping a: 10 mm (0.39 in)

NOISE, VIBRATION AND HARSHNESS (NVH) TROUBLESHOOTING

NVH Troubleshooting Chart

NVH Troubleshooting Chart

NICL0004S01

Use the chart below to help you find the cause of the symptom. The numbers indicate the order of inspection. Check each part in order. If necessary, repair or replace these parts.

Symptom		SUSPECTED PARTS (Possible cause)																		
		CLUTCH PEDAL (Free play out of adjustment)	CLUTCH LINE (Air in line)	MASTER CYLINDER PISTON CUP (Damaged)	OPERATING CYLINDER PISTON CUP (Damaged)	ENGINE MOUNTING (Loose)	RELEASE BEARING (Worn, dirty or damaged)	CLUTCH DISC (Out of true)	CLUTCH DISC (Runout is excessive)	CLUTCH DISC (Lining broken)	CLUTCH DISC (Dirty or burned)	CLUTCH DISC (Oily)	CLUTCH DISC (Worn out)	CLUTCH DISC (Hardened)	CLUTCH DISC (Lack of spline grease)	DIAPHRAGM SPRING (Damaged)	DIAPHRAGM SPRING (Out of tip alignment)	CLUTCH COVER (Distortion)	FLYWHEEL (Distortion)	
Clutch grabs/chatters	Clutch grabs/chatters					1														
	Clutch pedal spongy		1	2	2															
	Clutch noisy						1													
	Clutch slips	1										2	2			3		4	5	
	Clutch does not disengage	1	2	3	4				5	5	5	5	5		5	6	6	7		
Reference page		CL-6	CL-7	CL-8	CL-11	Refer to EM-49 , (QG18DE), EM-127 , (SR20DE).	CL-14	CL-17	CL-17	CL-17	CL-17	CL-17	CL-17	CL-17	CL-17	CL-17	CL-17	CL-17	CL-17	CL-18

CLUTCH SYSTEM

Components

Components

NICL0005

SEC. 300•305•306•465

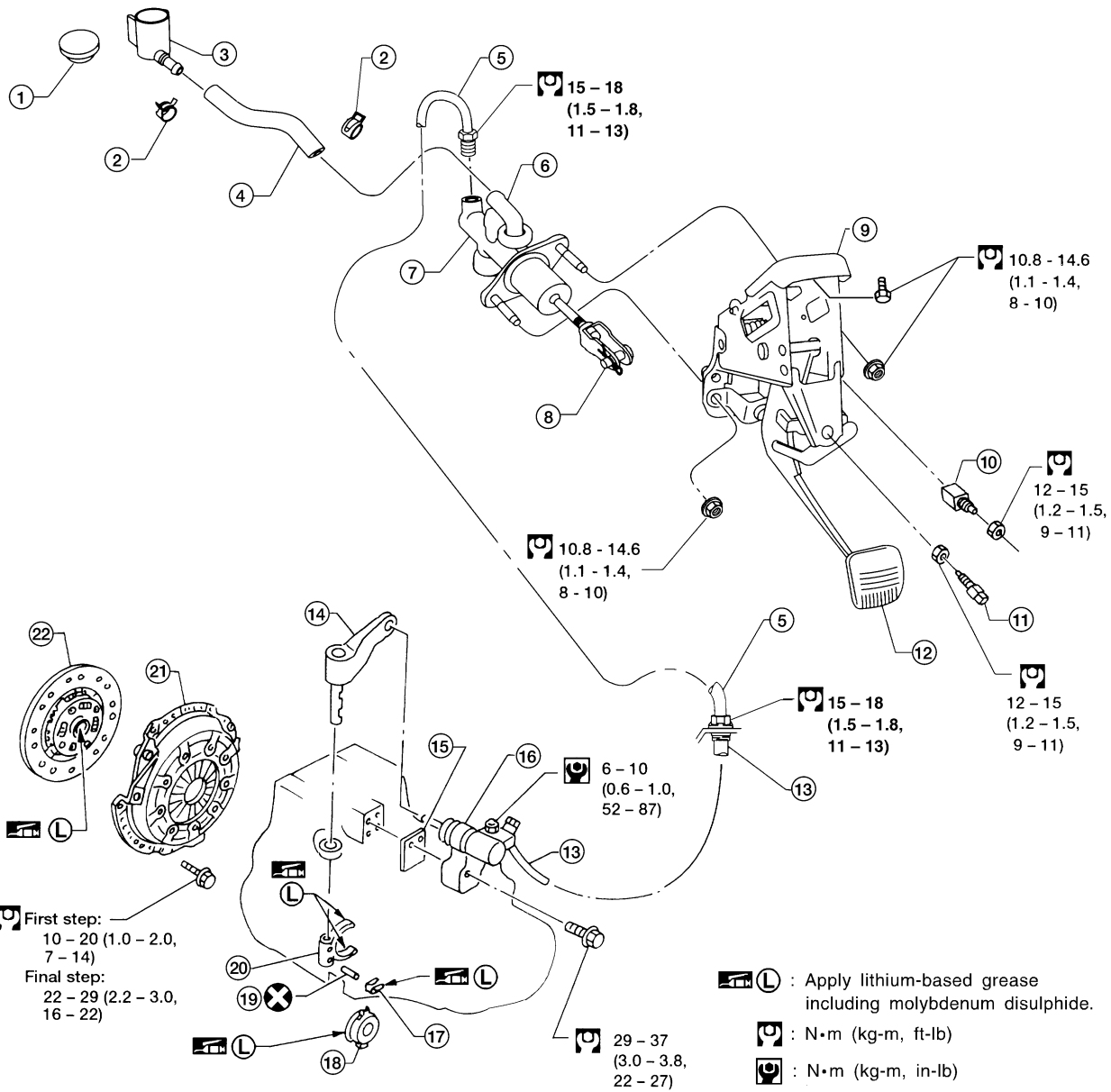

LCL047

- | | | |
|---------------------------|-----------------------------|----------------------------|
| 1. Reservoir cap | 9. Clutch pedal bracket | 16. Operating cylinder |
| 2. Hose clamp | 10. Clutch interlock switch | 17. Release bearing spring |
| 3. Reservoir tank | 11. ASCD clutch switch | 18. Release bearing |
| 4. Reservoir hose | 12. Clutch pedal | 19. Spring pin |
| 5. Clutch tube | 13. Clutch hose | 20. Clutch lever |
| 6. Nipple | 14. Withdrawal lever | 21. Clutch cover |
| 7. Clutch master cylinder | 15. Spacer | 22. Clutch disc |
| 8. Clevis | | |

GI
MA
EM
LC
EC
FE
CL
MT
AT
AX
SU
BR
ST
RS
BT
HA
SC
EL
IDX

CLUTCH SYSTEM

Inspection and Adjustment

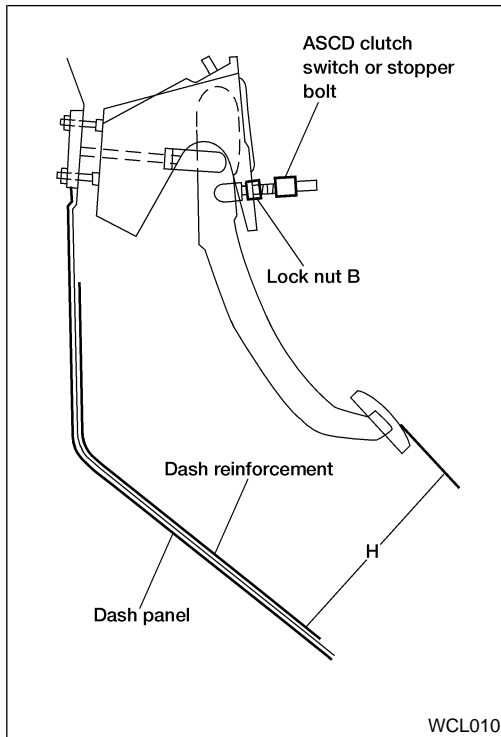

WCL010

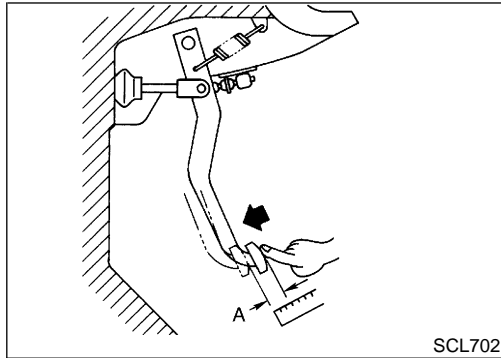

SCL702

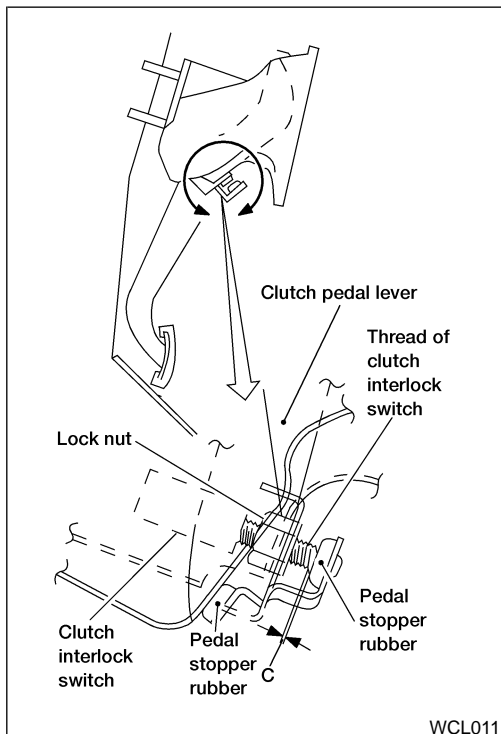

WCL011

Inspection and Adjustment

ADJUSTING CLUTCH PEDAL

NICL0006

NICL0006S01

NICL0006S0101

Pedal Height

1. Verify that clutch pedal height "H" is within specification.
 - Measure distance between the upper surface of dash reinforcement and pedal.

Pedal height "H":

156.1 - 166.1 mm (6.146 - 6.539 in)

2. Adjust pedal free play with master cylinder push rod. Then tighten lock nut.

Pedal free play "A":

9 - 16 mm (0.35 - 0.63 in)

- Push or step on clutch pedal until resistance is felt, and check the distance the pedal moves.

3. Adjust clearance "C" shown in the figure while fully depressing clutch pedal.

Clearance C:

0.1 - 1.0 mm (0.004 - 0.039 in)

CLUTCH SYSTEM

Inspection and Adjustment (Cont'd)

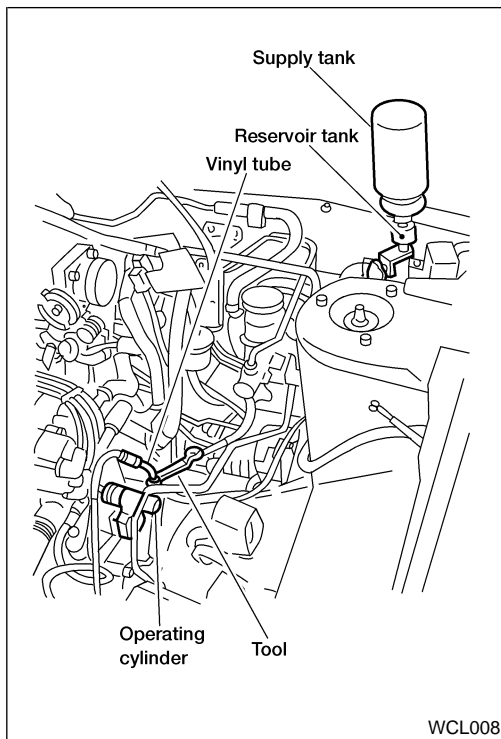

BLEEDING PROCEDURE

NICL0006S02

1. Bleed air from clutch operating cylinder according to the following procedure.

● **Carefully monitor fluid level at master cylinder during bleeding operation.**

a. Top off reservoir with recommended brake fluid.

CAUTION:

Be careful not to splash brake fluid on painted areas; it may cause paint damage. If brake fluid is splashed on painted areas, wash it away with water immediately.

b. Connect a transparent vinyl tube to air bleeder valve.

c. Slowly depress the clutch pedal to its full stroke and release it completely. Repeat this operation several times at 2 to 3 seconds intervals.

d. Open the air bleeder with the clutch pedal fully depressed.

e. Close the air bleeder.

f. Release the clutch pedal and wait at least 5 seconds.

g. Repeat steps c through f mentioned above, then air bubbles will no longer appear at the damper in the brake fluid.

2.

Air bleeder valve tightening torque:

 : 6 - 10 N·m (0.6 - 1.0 kg·m, 52 - 87 in·lb)

GI

MA

EM

LC

EC

FE

CL

MT

AT

AX

SU

BR

ST

RS

BT

HA

SC

EL

IDX

CLUTCH MASTER CYLINDER

Components

Components

NICL0007

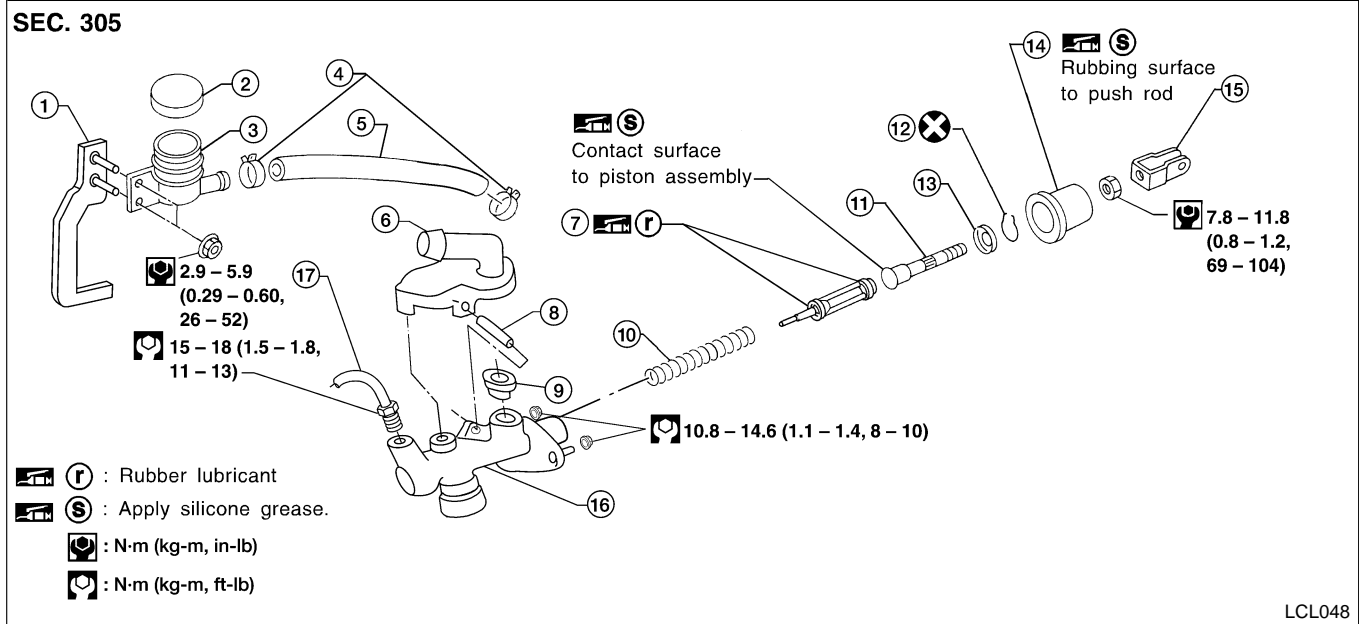

- | | | |
|-------------------|--------------------------|-------------------|
| 1. Bracket | 7. Piston assembly seals | 13. Stopper |
| 2. Reservoir cap | 8. Pin | 14. Dust cover |
| 3. Reservoir tank | 9. Seal | 15. Clevis |
| 4. Hose clamps | 10. Return spring | 16. Cylinder body |
| 5. Reservoir hose | 11. Push rod | 17. Clutch tube |
| 6. Nipple | 12. Stopper ring | |

Removal

NICL0008

1. Drain brake fluid.

CAUTION:

Be careful not to splash brake fluid on painted areas; it may cause paint damage. If brake fluid is splashed on painted areas, wash it away with water immediately.



2. Remove clutch tube flare nut using a flare nut wrench.
3. Remove reservoir hose.
4. Remove the snap pin from the clevis pin and remove the clutch pedal from the clevis.
5. Unscrew master cylinder assembly mounting nuts and reservoir tank bracket mounting bolts to remove master cylinder assembly from vehicle.

CLUTCH MASTER CYLINDER

Installation

Installation

NICL0009

1. Install reservoir hose.
2. Connect clutch tube to master cylinder assembly, and hand-tighten flare nut.
3. Install master cylinder assembly to vehicle, and tighten mounting nuts to the specified torque.
 : 10.8 - 14.6 N·m (1.1 - 1.4 kg·m, 8 - 10 ft·lb)
4. Tighten reservoir tank bracket mounting bolts.
 : 2.9 - 5.9 N·m (0.29 - 0.60 kg·m, 26 - 52 in·lb)
5. Tighten clutch tube flare nut using a flare nut torque wrench.
 : 15 - 18 N·m (1.5 - 1.8 kg·m, 11 - 13 ft·lb)
6. After installing clevis pin, install snap pin to connect clutch pedal to push rod.
7. After finishing the operation, bleed air from clutch piping. (Refer to "BLEEDING PROCEDURE", CL-7.)

GI

MA

EM

LC

EC

FE

CL

MT

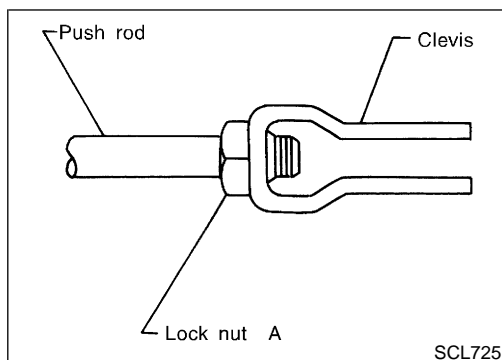

Disassembly

NICL0010

1. Loosen push rod lock nut A to remove clevis and lock nut A.
2. Remove dust cover.
3. Remove stopper ring and stopper, and remove push rod from cylinder body. During removal, keep push rod depressed, to prevent piston inside master cylinder from popping out.
4. Remove piston assembly from cylinder body.
5. Remove spring.
6. Remove pin using pin punch then remove nipple and seal.

AT

AX

SU

BR

Inspection

NICL0011

Inspect for the following, and replace parts if necessary.

- Damage, wear, rust, and pinholes on the cylinder inner wall
- Damage and deformation of the reservoir tank
- Weak spring
- Crack or deformation of the dust cover

ST

RS

BT

HA

Assembly

NICL0012

1. Install spring.
2. Apply rubber lubricant to the sliding part of piston assembly, and insert piston assembly into cylinder body.
3. After installing stopper to push rod, install stopper ring while keeping piston assembly depressed by hand, so that piston assembly will not pop out.

SC

EL

IDX

CAUTION:

Stopper ring cannot be reused. Always use a new stopper ring for assembly.

4. Install dust cover.

CLUTCH MASTER CYLINDER

Assembly (Cont'd)

5. Install clevis to push rod, and tighten lock nut A to the specified torque.
 : **7.8 - 11.8 N-m (0.8 - 1.2 kg-m, 69 - 104 in-lb)**
6. Install seal and nipple to cylinder body, and install pin using a pin punch.

Components

NICL0019

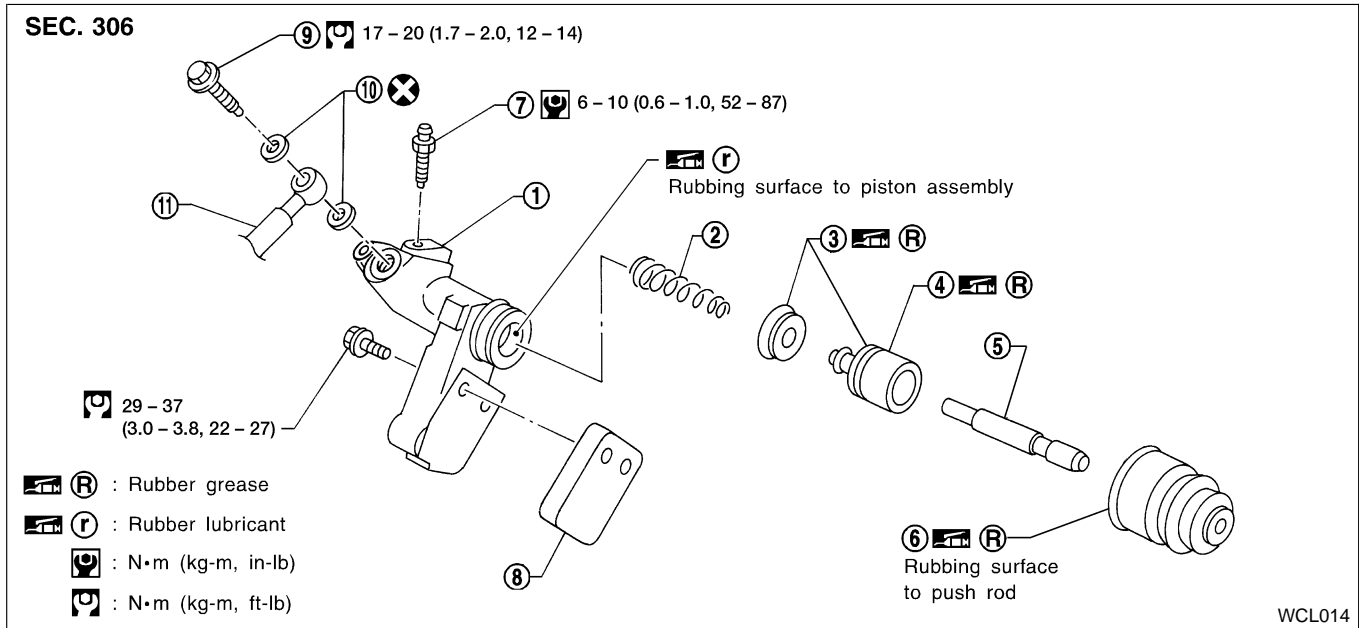

- | | | |
|------------------|----------------|-------------------|
| 1. Cylinder body | 5. Push rod | 9. Union bolt |
| 2. Piston spring | 6. Dust cover | 10. Copper washer |
| 3. Piston cup | 7. Air bleeder | 11. Clutch hose |
| 4. Piston | 8. Spacer | |

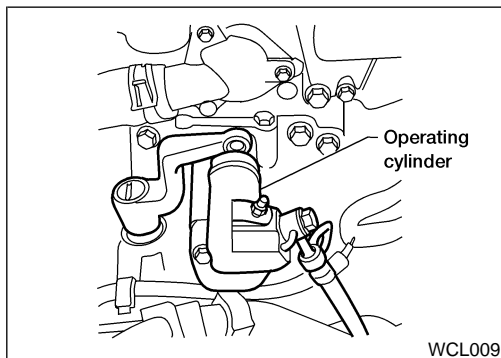

Removal

NICL0020

1. Drain brake fluid.

CAUTION:

Be careful not to splash brake fluid on painted areas; it may cause paint damage. If brake fluid is splashed on painted areas, wash it away with water immediately.

2. Remove union bolt and clutch hose from operating cylinder.
3. Remove operating cylinder mounting bolts, and remove cylinder from vehicle.

Disassembly

NICL0021

Remove dust cover, and remove piston assembly from cylinder body.

GI
MA
EM
LC
EC
FE
CL
MT
AT
AX
SU
BR
ST
RS
BT
HA
SC
EL
IDX

OPERATING CYLINDER

Inspection

Inspection

NICL0022

Inspect for the following, and replace parts if necessary.

- Damage, foreign material, wear, rust, and pinholes on the cylinder inner surface, piston, and sliding part of piston cup
- Weak spring
- Crack or deformation of dust cover

Assembly

NICL0023

1. Apply rubber lubricant to the overall inside surface of the cylinder body. Also, apply rubber grease to the piston. Then insert the piston assembly into the cylinder body.
2. Install dust cover.

Installation

NICL0024

Install the components in the reverse order of removal. Adhere to the operations described below.

CAUTION:

Install the hose without twisting it.

- **The copper washer of the union bolt should not be reused. Always use a new copper washer for installation.**
- **After finishing the operation, bleed air from the clutch piping. Refer to “BLEEDING PROCEDURE”, CL-7.**

Removal

NICL0025

1. Remove air cleaner and air duct.
2. Drain brake fluid.

CAUTION:

Be careful not to splash brake fluid on painted areas; it may cause paint damage. If brake fluid is splashed on painted areas, wash it away with water immediately.

3. Remove flare nut from cylinder body using a flare nut wrench.
4. Remove clutch hose from operating cylinder.
5. Remove clutch hose and clutch tube from bracket by removing lock plate.

GI

MA

EM

LC

EC

FE

CL

MT

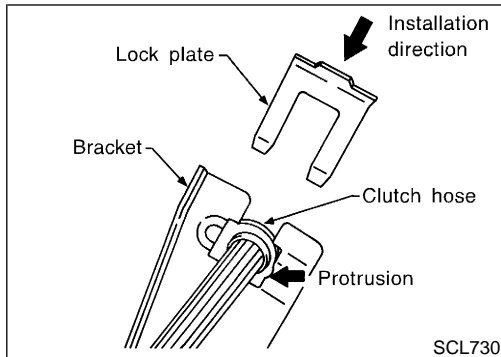

Installation

NICL0026

1. When installing clutch hose to bracket, face lock plate in the correct direction as shown to secure clutch hose.

CAUTION:

Install clutch hose without twisting or bending it.

2. Tighten flare nut to the specified torque, using a flare nut wrench.

: 15 - 18 N·m (1.5 - 1.8 kg·m, 11 - 13 ft·lb)

CAUTION:

Be careful not to damage flare nut and clutch tube.

3. Install clutch hose to operating cylinder, and tighten mounting bolt to the specified torque.

: 17 - 19 N·m (1.7 - 2.0 kg·m, 13 - 14 ft·lb)

4. Bleed air from the clutch piping. Refer to "BLEEDING PROCEDURE", CL-7.
5. Install air cleaner and air duct.

AT

AX

SU

BR

ST

RS

BT

HA

SC

EL

IDX

CLUTCH RELEASE MECHANISM

Components

Components

NICL0027

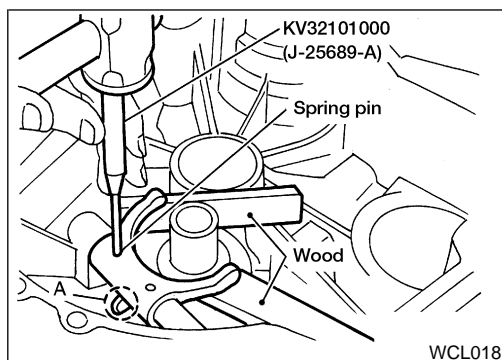
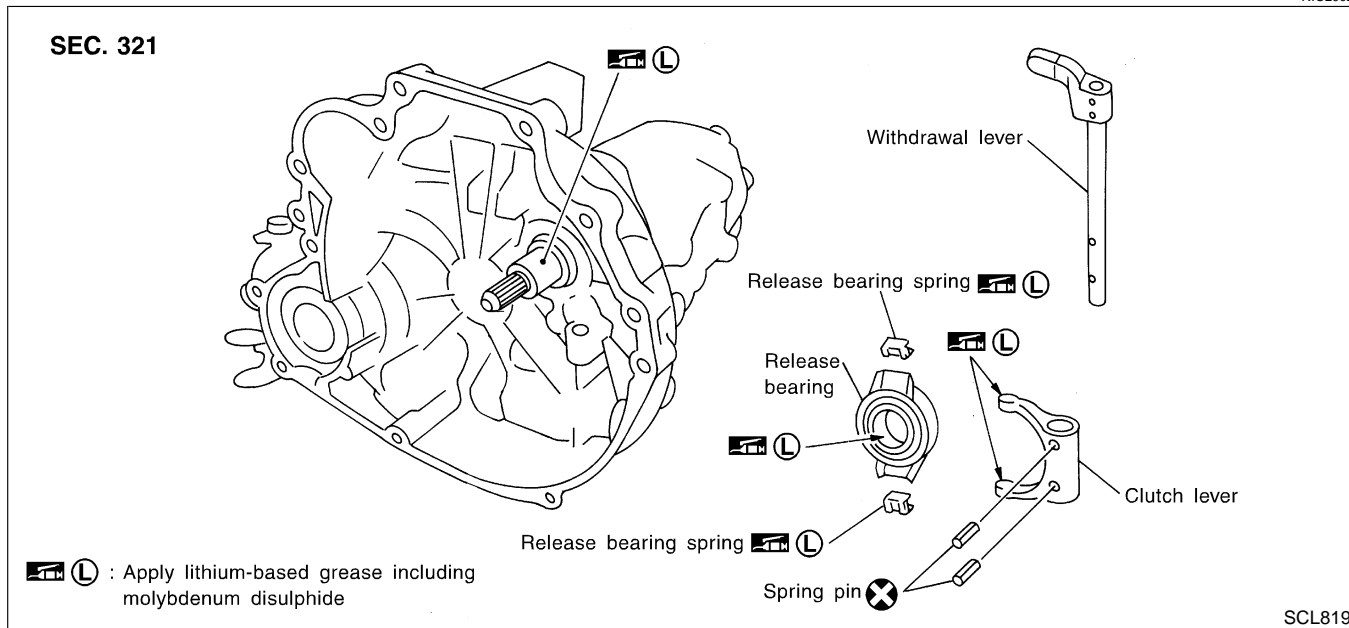

Removal

1. Remove manual transaxle from vehicle. Refer to **MT-12**, "Removal".
2. Move withdrawal lever enough to remove release bearing and release bearing spring, and remove release bearing from clutch lever.
3. Support clutch lever claws with an appropriate wood block, align retaining pin with A in the figure, and drive out spring pins using a pin punch (J25689-A).
4. Pull out withdrawal lever and remove clutch lever from clutch housing.

NICL0028

Inspection

- Replace the release bearing if it is seized, damaged, faulty in rotation direction, or has poor aligning function.
- Replace the withdrawal lever if its contact surface is worn abnormally.
- Replace the clutch lever if its contact surface is worn abnormally.

NICL0029

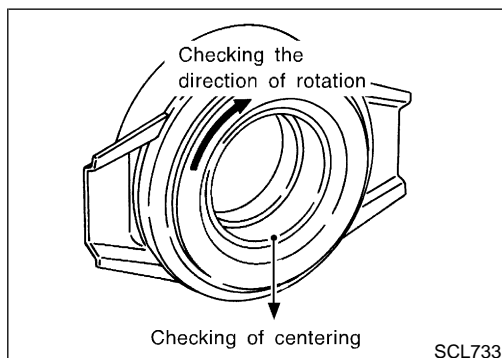

Installation

CAUTION:

- Be sure to apply grease to the clutch components. Otherwise, abnormal noise, poor clutch disengagement, or clutch damage may occur. Wipe the excess grease off completely, because it may cause the clutch components to slip and shudder.
- Keep the clutch disc facing, pressure plate, and flywheel free of oil and grease.

NICL0030

CLUTCH RELEASE MECHANISM

Installation (Cont'd)

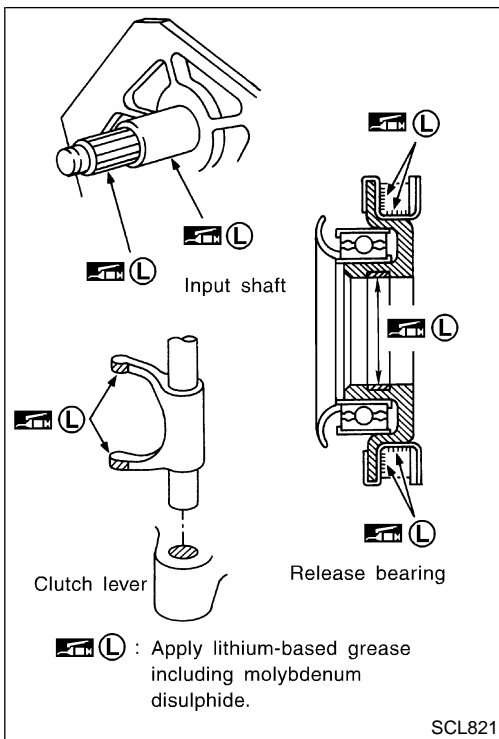

- Clean old grease and abrasive materials off the grease application area.
- Apply approximately 1 mm (0.04 in)-thick clutch sleeve grease evenly on the sliding part of the clutch lever and the release bearing spring.
- Apply just enough clutch sleeve grease to fill up the release bearing inner groove.
- Apply the clutch grease to the clutch disc and the input shaft spline. Install the clutch disc to the input shaft, remove the excess grease around the shaft, and remove the clutch disc.
- Lightly and evenly apply the clutch sleeve grease on the sliding part of the release bearing, install the release bearing, remove the excess grease around the bearing, and remove the release bearing.

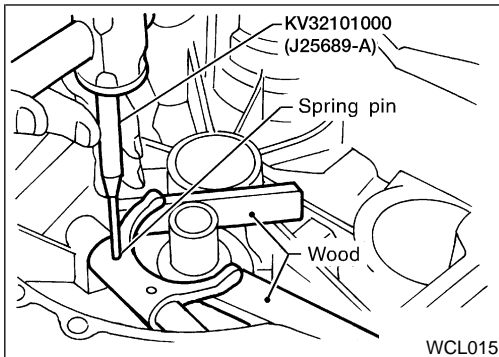

1. Assemble clutch lever to clutch housing, and insert withdrawal lever.
2. Support clutch lever claws with an appropriate wood block, and install new spring pins using a pin punch.

CAUTION:
Spring pins cannot be reused.

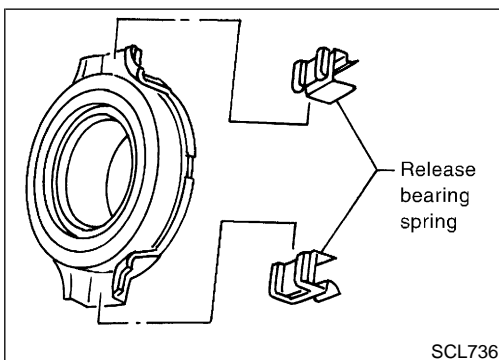

3. Install release bearing springs to release bearing as shown in the figure.

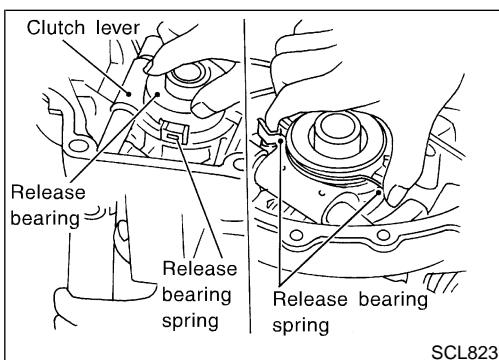

4. Operate withdrawal lever manually, press clutch spring from both sides, and install release bearing to clutch lever securely.
5. Make sure a click is heard when release bearing spring is pressed from both sides.

GI
MA
EM
LC
EC
FE
CL
MT
AT
AX
SU
BR
ST
RS
BT
HA
SC
EL
IDX

CLUTCH RELEASE MECHANISM

Installation (Cont'd)

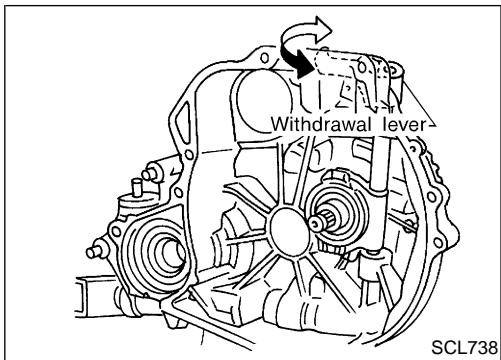

6. Make sure all parts operate smoothly when operating with withdrawal lever.
7. Install manual transaxle. Refer to **MT-14**, "Installation".

CAUTION:
Remove any excess grease with a shop towel.

Components

NICL0031

NOTE:

Late production QG18DE clutch disc shown, others similar.

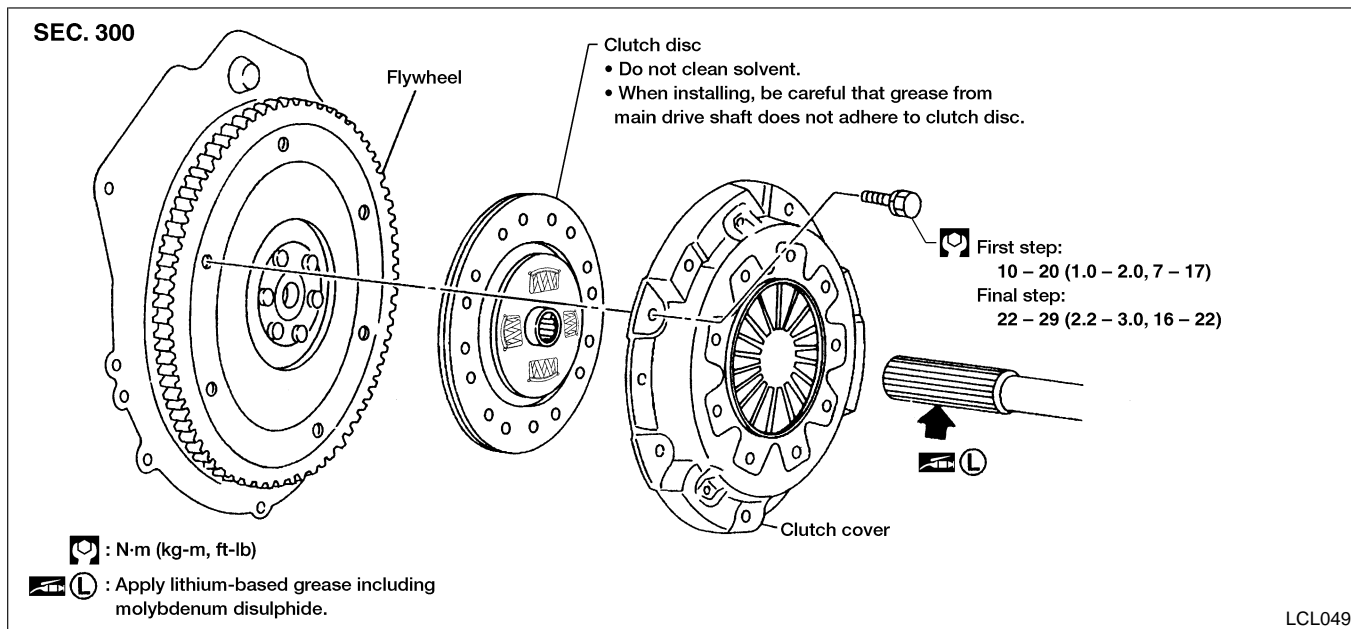

GI

MA

EM

LC

EC

FE

CL

MT

AT

AX

SU

BR

ST

RS

BT

HA

SC

NICL0032

Inspection and Adjustment

CLUTCH DISC

NICL0032S01

NOTE:

Late production QG18DE clutch disc shown, others similar.

EL

IDX

CLUTCH DISC, CLUTCH COVER AND FLYWHEEL

Inspection and Adjustment (Cont'd)

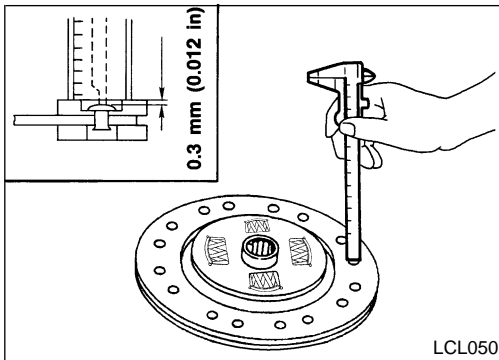

Check clutch disc for wear of facing.

**Wear limit of facing surface to rivet head:
0.3 mm (0.012 in)**

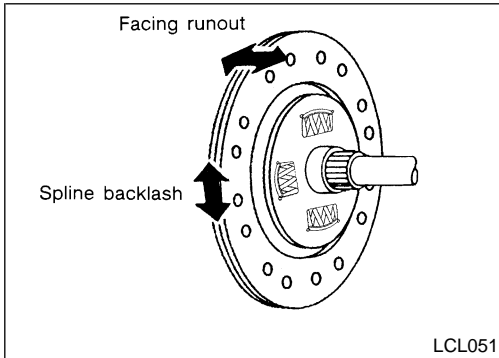

- Check clutch disc for backlash of spline and runout of facing.
 - Maximum backlash of spline (at outer edge of disc):
0.9 mm (0.035 in)**
 - Runout limit:
1.0 mm (0.039 in)**
 - Distance of runout check point (from hub center):
102.5 mm (4.04 in)**
- Check clutch disc for burns, discoloration or oil or grease leakage. Replace if necessary.

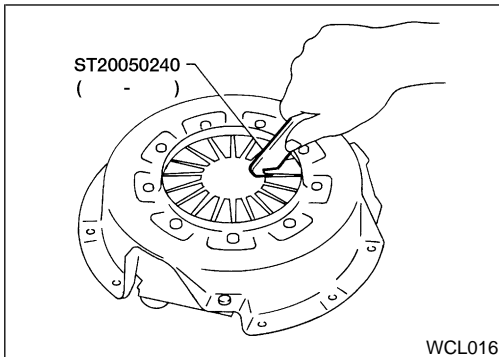

CLUTCH COVER AND FLYWHEEL

- Check clutch cover installed on vehicle for unevenness of diaphragm spring toe height. NICL0032S02
 - Uneven limit:**
 - QG18DE 0.88 mm (0.0346 in)**
 - SR20DE 0.7 mm (0.028 in)**
- If out of limit, adjust the height with Tool.

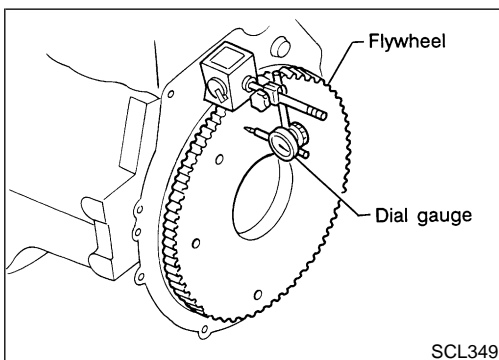

FLYWHEEL INSPECTION

- Check contact surface of flywheel for slight burns or discoloration. Clean flywheel with emery paper. NICL0032S03
- Check flywheel runout.
 - Maximum allowable runout:**
 - Refer to EM-62, (QG18DE), EM-139, (SR20DE), "FLYWHEEL/DRIVE PLATE RUNOUT".**

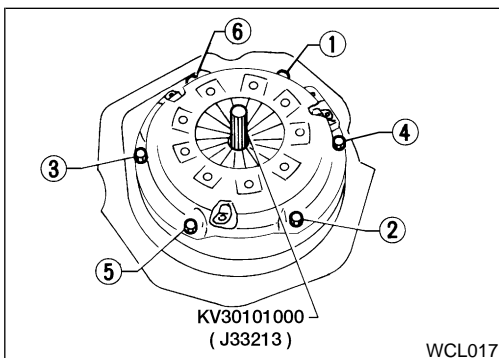

Installation

- Insert Tool into clutch disc hub when installing clutch cover and disc. NICL0033
- Be careful not to allow grease to contaminate clutch facing.
- Tighten bolts in numerical order by 2 steps.
 - First step:**
 - ⌚ : 10 - 20 N·m (1.0 - 2.0 kg·m, 7 - 14 ft·lb)**
 - Final step:**
 - ⌚ : 22 - 29 N·m (2.2 - 3.0 kg·m, 16 - 22 ft·lb)**

SERVICE DATA AND SPECIFICATIONS (SDS)

Clutch Control System

Clutch Control System

NICL0034

Type of clutch control	Hydraulic
------------------------	-----------

GI

Clutch Master Cylinder

NICL0035
Unit: mm (in)

Inner diameter	15.87 (5/8)
----------------	-------------

MA

Clutch Operating Cylinder

NICL0036
Unit: mm (in)

Inner diameter	19.05 (3/4)
----------------	-------------

EM

LC

Clutch Disc

NICL0038
Unit: mm (in)

Engine model	QG18DE	SR20DE
Model	215	
Facing size (Outer dia. × inner dia. × thickness)	215 × 145 × 3.5 (8.46 × 5.71 × 0.138)	215 × 140 × 3.5 (8.46 × 5.51 × 0.138)
Thickness of disc assembly With load	7.7 - 8.3 (0.303 - 0.327) with 4,900 N (499.8 kg, 1,101.5 lb)	7.6 - 8.0 (0.299 - 0.315) with 4,900 N (499.8 kg, 1101.5 lb)
Wear limit of facing surface to rivet head	0.3 (0.012)	
Runout limit of facing	1.0 (0.039)	
Distance of runout check point (from the hub center)	102.5 (4.04)	
Maximum backlash of spline (at outer edge disc)	0.9 (0.035)	

EC

FE

CL

MT

AT

AX

Clutch Cover

NICL0039
Unit: mm (in)

Engine model	QG18DE	SR20DE
Model	215	
Full-load	4,900 N (499.8 kg, 1,101.5 lb)	
Uneven limit of diaphragm spring toe height	0.88 (0.0346)	0.7 (0.028)

SU

BR

ST

RS

Clutch Pedal

NICL0040
Unit: mm (in)

Pedal height "H ₁ "*	156.1 - 166.1 (6.146 - 6.539)
Pedal free play "A" (at pedal pad)	9 - 16 (0.35 - 0.63)
Clearance "C" between pedal stopper rubber and clutch interlock switch threaded end while clutch pedal is fully depressed.	0.1 - 1.0 (0.004 - 0.039)

BT

HA

*: Measured from surface of dash reinforcement panel

SC

EL

IDX

NOTES