

SECTION MA
MAINTENANCE

A
B
C

CONTENTS

<p>PRECAUTIONS 3 Precautions for Supplemental Restraint System (SRS) "AIR BAG" and "SEAT BELT PRE-TENSIONER" 3</p> <p>PREPARATION 4 Special Service Tool 4 Commercial Service Tool 4</p> <p>GENERAL MAINTENANCE 5 Explanation of General Maintenance 5 General Maintenance 5</p> <p>PERIODIC MAINTENANCE 7 Introduction of Periodic Maintenance 7 Schedule 1 7 EMISSION CONTROL SYSTEM MAINTENANCE 7 CHASSIS AND BODY MAINTENANCE 10 Schedule 2 11 EMISSION CONTROL SYSTEM MAINTENANCE 11 CHASSIS AND BODY MAINTENANCE 12</p> <p>RECOMMENDED FLUIDS AND LUBRICANTS 13 Fluids and Lubricants 13 SAE Viscosity Number 14 Anti-freeze Coolant Mixture Ratio 14</p> <p>ENGINE MAINTENANCE (QG18DE ENGINE) 16 Checking Drive Belts 16 Changing Engine Coolant 16 DRAINING ENGINE COOLANT 16 REFILLING ENGINE COOLANT 17 FLUSHING COOLING SYSTEM 18 Checking Fuel Lines 19 Changing Air Cleaner Filter 19 Changing Engine Oil 20 Changing Oil Filter 20 Changing Spark Plugs (Double Platinum - Tipped Type) 21 Checking EVAP Vapor Lines 22</p> <p>ENGINE MAINTENANCE (QR25DE ENGINE) 23 Checking Drive Belts 23 Changing Engine Coolant 23</p>	<p> DRAINING ENGINE COOLANT 23 REFILLING ENGINE COOLANT 24 FLUSHING COOLING SYSTEM 25 Checking Fuel Lines 25 Changing Air Cleaner Filter 26 Changing Engine Oil 26 Changing Oil Filter 27 Changing Spark Plugs (Double Platinum - Tipped Type) 27 Checking EVAP Vapor Lines 28</p> <p>CHASSIS AND BODY MAINTENANCE 29 Checking Exhaust System 29 Checking Clutch Fluid Level and Leaks 29 Checking M/T Oil 29 Changing M/T Oil 29 Checking A/T Fluid 30 Changing A/T Fluid 31 Balancing Wheels 31 Tire Rotation 31 Checking Brake Fluid Level and Leaks 32 Checking Brake Lines and Cables 32 Changing Brake Fluid 32 Checking Disc Brakes 32 ROTOR 32 CALIPER 33 PAD 33 Checking Drum Brake 33 WHEEL CYLINDER 33 DRUM 33 LINING 34 Checking Steering Gear and Linkage 34 STEERING GEAR 34 STEERING LINKAGE 34 Checking Power Steering Fluid and Lines 34 CHECKING FLUID LEVEL 34 CHECKING LINES 34 Axle and Suspension Parts 35 Drive Shaft 36 Lubricating Locks, Hinges and Hood Latches 36 Checking Seat Belt, Buckles, Retractors, Anchors</p>
---	---

D
E
F
G
H
I
J
K

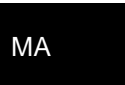

M

and Adjusters	37	Engine Maintenance (QR25DE)	38
SERVICE DATA AND SPECIFICATIONS (SDS)	38	BELT DEFLECTION AND TENSION	38
Engine Maintenance (QG18DE)	38	SPARKPLUGS (DOUBLE PLATINUM-TIPPED)..	38
BELT DEFLECTION AND TENSION	38	Chassis and Body Maintenance	38
SPARKPLUGS (DOUBLE PLATINUM-TIPPED)..	38	WHEEL BALANCE	38

PRECAUTIONS

PRECAUTIONS

PF0:00001

Precautions for Supplemental Restraint System (SRS) “AIR BAG” and “SEAT BELT PRE-TENSIONER”

ELS0001F

The Supplemental Restraint System such as “AIR BAG” and “SEAT BELT PRE-TENSIONER”, used along with a front seat belt, helps to reduce the risk or severity of injury to the driver and front passenger for certain types of collision. Information necessary to service the system safely is included in the SRS and SB section of this Service Manual.

WARNING:

- To avoid rendering the SRS inoperative, which could increase the risk of personal injury or death in the event of a collision which would result in air bag inflation, all maintenance must be performed by an authorized NISSAN/INFINITI dealer.
- Improper maintenance, including incorrect removal and installation of the SRS, can lead to personal injury caused by unintentional activation of the system. For removal of Spiral Cable and Air Bag Module, see the SRS section.
- Do not use electrical test equipment on any circuit related to the SRS unless instructed to in this Service Manual. SRS wiring harnesses can be identified by yellow and/or orange harnesses or harness connectors.

A
B
C
D
E
F
G
H
I
J
K
MA
M

MA

PREPARATION

PREPARATION

PFP:00002

Special Service Tool

ELS0001G

The actual shapes of Kent-Moore tools may differ from those of special service tools illustrated here.

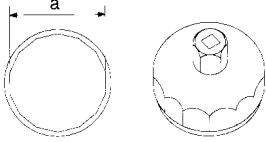
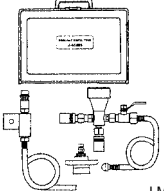
Tool number (Kent-Moore No.) Tool name	Description
KV10115801 (J-37140-A) Oil filter cap wrench <div style="text-align: center;">  <p>NT375</p> </div>	Removing oil filter a: 64.3 mm (2.531 in)
— (J-45695) Coolant refill tool <div style="text-align: center;">  <p>LMA053</p> </div>	Refilling engine coolant

Commercial Service Tool

ELS0001H

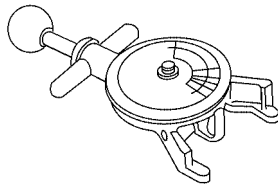
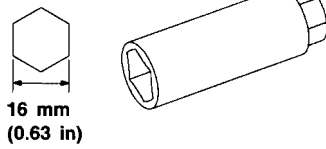
Tool name (Kent-Moore No.)	Description
Belt tension gauge (BT3373-F) <div style="text-align: center;">  <p>AMA126</p> </div>	Checking drive belt tension of QG18DE engine
Spark plug wrench <div style="text-align: center;">  <p>16 mm (0.63 in)</p> <p>S-NT047</p> </div>	Removing and installing spark plugs

GENERAL MAINTENANCE

GENERAL MAINTENANCE

PFP:00000

Explanation of General Maintenance

ELS000II

General Maintenance

ELS000IJ

General maintenance includes those items which should be checked during the normal day-to-day operation of the vehicle. They are essential if the vehicle is to continue operating properly. The owners can perform checks and inspections themselves or they can have their NISSAN dealers do them.

OUTSIDE THE VEHICLE

The maintenance items listed here should be performed from time to time, unless otherwise specified.

Item		Reference page
Tires	Check the pressure including the spare, at least once a month and always prior to a long distance trip. Adjust to the specified pressure if necessary. Check carefully for damage, cuts or excessive wear.	—
Wheel nuts	When checking the tires, make sure no nuts are missing, and check for any loose nuts. Tighten if necessary.	—
Windshield	Clean the windshield on a regular basis. Check the windshield at least every six months for cracks or other damage. Repair as necessary.	—
Tire rotation	Tires should be rotated every 12,000 km (7,500 miles).	MA-31, "Tire Rotation"
Wheel alignment and balance	If the vehicle pulls to either side while driving on a straight and level road, or if you detect uneven or abnormal tire wear, there may be a need for wheel alignment. If the steering wheel or seat vibrates at normal highway speeds, wheel balancing may be needed.	FSU-6, "Front Wheel Alignment" and MA-31, "Balancing Wheels"
Windshield wiper blades	Check for cracks or wear if they do not wipe properly.	—
Doors and engine hood	Check that all doors and the engine hood operate smoothly as well as the trunk lid and back hatch. Also make sure that all latches lock securely. Lubricate if necessary. Make sure that the secondary latch keeps the hood from opening when the primary latch is released. When driving in areas using road salt or other corrosive materials, check lubrication frequently.	MA-36, "Lubricating Locks, Hinges and Hood Latches"
Lamps	Make sure that the headlamps, stop lamps, tail lamps, turn signal lamps, and other lamps are all operating properly and installed securely. Also check headlamp aim. Clean the headlamps on a regular basis.	—

INSIDE THE VEHICLE

The maintenance items listed here should be checked on a regular basis, such as when performing periodic maintenance, and cleaning the vehicle.

Item		Reference page
Warning lamps and buzzers/chimes	Make sure that all warning lamps and buzzers/chimes are operating properly.	—
Windshield wiper and washer	Check that the wipers and washer operate properly and that the wipers do not streak.	—
Windshield defroster	Check that the air comes out of the defroster outlets properly and in sufficient quantity when operating the heater or air conditioning.	—
Steering wheel	Check that it has the specified play. Be sure to check for changes in the steering condition, such as excessive play, hard steering or strange noises. Free play: Less than 35 mm (1.38 in)	—
Seats	Check seat position controls such as seat adjusters, seat back recliner, etc. to make sure they operate smoothly and that all latches lock securely in every position. Check that the head restraints move up and down smoothly and that the locks (if equipped) hold securely in all latched positions. Check that the latches lock securely for folding-down rear seat backs.	—
Seat belts	Check that all parts of the seat belt system (e.g. buckles, anchors, adjusters and retractors) operate properly and smoothly and are installed securely. Check the belt webbing for cuts, fraying, wear or damage.	SB-7, "Seat Belt Inspection"
Accelerator pedal	Check the pedal for smooth operation and make sure the pedal does not catch or require uneven effort. Keep the floor mats away from the pedal.	—

GENERAL MAINTENANCE

Item		Reference page
Clutch pedal	Make sure the pedal operates smoothly and check that it has the proper free play.	CL-7, "CLUTCH PEDAL INSPECTION AND ADJUSTMENT"
Brakes	Check that the brake does not pull the vehicle to one side when applied.	—
Brake pedal and booster	Check the pedal for smooth operation and make sure it has the proper distance under it when depressed fully. Check the brake booster function. Be sure to keep floor mats away from the pedal.	BR-12, "BRAKE PEDAL HEIGHT" and BR-16, "OPERATING CHECK"
Parking brake	Check that the lever has the proper travel and make sure that the vehicle is held securely on a fairly steep hill when only the parking brake is applied.	PB-2, "Inspection"
Automatic transaxle "Park" mechanism	Check that the lock release button on the selector lever operates properly and smoothly. On a fairly steep hill check that the vehicle is held securely with the selector lever in the "P" position without applying any brakes.	—

UNDER THE HOOD AND VEHICLE

The maintenance items listed here should be checked periodically (e.g. each time you check the engine oil or refuel).

Item		Reference page	
		QG18DE	QR25DE
Windshield washer fluid	Check that there is adequate fluid in the tank.	—	
Engine coolant level	Check the coolant level when the engine is cold.	CO-7, "CHECKING COOLING SYSTEM FOR LEAKS"	CO-24, "System Check"
A/C condenser, radiator and hoses	Check the front of the condenser and radiator and clean off any dirt, insects, leaves, etc., that may have accumulated. Make sure the radiator hoses have no cracks, deformation, deterioration or loose connections.	—	
Brake and clutch fluid levels	Make sure that the brake and clutch fluid levels are between the "MAX" and "MIN" lines on the reservoirs.	MA-32, "Checking Brake Fluid Level and Leaks" and MA-29, "Checking Clutch Fluid Level and Leaks"	
Battery	Check the fluid level in each cell. It should be between the "MAX" and "MIN" lines. Vehicles operated in high temperatures or under severe conditions require frequent checks of the battery fluid level.	—	
Engine drive belts	Make sure that no belt is frayed, worn, cracked or oily.	MA-16, "Checking Drive Belts"	MA-23, "Checking Drive Belts"
Engine oil level	Check the level on the dipstick after parking the vehicle on a level spot and turning off the engine.	—	—
Power steering fluid level and lines	Check the level is between the "MAX" and "MIN" lines on the reservoir with the engine off. Check the lines for improper attachment, leaks, cracks, etc.	MA-34, "Checking Power Steering Fluid and Lines"	
Automatic transaxle fluid level	Check the level on the dipstick after putting the selector lever in "P" with the engine idling.	MA-30, "Checking A/T Fluid"	
Exhaust system	Make sure there are no loose supports, cracks or holes. If the sound of the exhaust seems unusual or there is a smell of exhaust fumes, immediately locate the trouble and correct it.	MA-29, "Checking Exhaust System"	
Underbody	The underbody is frequently exposed to corrosive substances such as those used on icy roads or to control dust. It is very important to remove these substances, otherwise rust will form on the floor pan, frame, fuel lines and around the exhaust system. At the end of winter, the underbody should be thoroughly flushed with plain water, being careful to clean those areas where mud and dirt can easily accumulate.	—	
Fluid leaks	Check under the vehicle for fuel, oil, water or other fluid leaks after the vehicle has been parked for a while. Water dripping from the air conditioner after use is normal. If you should notice any leaks or gasoline fumes are evident, check for the cause and correct it immediately.	—	

PERIODIC MAINTENANCE

PERIODIC MAINTENANCE

PFP:00026

Introduction of Periodic Maintenance

ELS0001K

Two different maintenance schedules are provided, and should be used, depending upon the conditions in which the vehicle is mainly operated. **After 60,000 miles (96,000 km) or 48 months, continue the periodic maintenance at the same mileage/time intervals.**

Schedule 1	<p>Follow Periodic Maintenance Schedule 1 if your driving habits frequently includes one or more of the following driving conditions:</p> <ul style="list-style-type: none"> ● Repeated short trips of less than 5 miles (8 km). ● Repeated short trips of less than 10 miles (16 km) with outside temperatures remaining below freezing. ● Operating in hot weather in stop-and-go "rush hour" traffic. ● Extensive idling and/or low speed driving for long distances, such as police, taxi or door-to-door delivery use. ● Driving in dusty conditions. ● Driving on rough, muddy, or salt spread roads. ● Towing a trailer, using a camper or a car-top carrier. 	Emission Control System Maintenance	MA-7. "EMIS- SION CON- TROL SYSTEM MAINTENANCE"
		Chassis and Body Maintenance	MA-10. "CHAS- SIS AND BODY MAINTENANCE"
Schedule 2	<p>Follow Periodic Maintenance Schedule 2 if none of the driving conditions shown in Schedule 1 apply to your driving habits.</p>	Emission Control System Maintenance	MA-11. "EMIS- SION CON- TROL SYSTEM MAINTENANCE"
		Chassis and Body Maintenance	MA-12. "CHAS- SIS AND BODY MAINTENANCE"

Schedule 1

EMISSION CONTROL SYSTEM MAINTENANCE

ELS0001L

Abbreviations: R = Replace. I = Inspect. Correct or replace if necessary. []: At the mileage intervals only

MAINTENANCE OPERATION		MAINTENANCE INTERVAL								Reference Section - Page or - Content Title	
Perform at number of miles, kilometers or months, whichever comes first.	Miles x 1,000 (km x 1,000) Months	3.75	7.5	11.25	15	18.75	22.5	26.25	30	QG18DE	QR25DE
		(6) 3	(12) 6	(18) 9	(24) 12	(30) 15	(36) 18	(42) 21	(48) 24		
Drive belt	NOTE (1)									MA-16. "Checking Drive Belts"	MA-23. "Checking Drive Belts"
Air cleaner filter	NOTE (2)								[R]	MA-19. "Changing Air Cleaner Filter"	MA-26. "Changing Air Cleaner Filter"
EVAP vapor lines									I*	MA-22. "Checking EVAP Vapor Lines"	MA-28. "Checking EVAP Vapor Lines"

PERIODIC MAINTENANCE

MAINTENANCE OPERATION		MAINTENANCE INTERVAL								Reference Section - Page or - Content Title	
Perform at number of miles, kilometers or months, whichever comes first.	Miles x 1,000 (km x 1,000)	3.75 (6)	7.5 (12)	11.25 (18)	15 (24)	18.75 (30)	22.5 (36)	26.25 (42)	30 (48)	QG18DE	QR25DE
	Months	3	6	9	12	15	18	21	24		
Fuel lines									I*	MA-19. "Checking Fuel Lines"	MA-25. "Checking Fuel Lines"
Fuel filter	NOTE (3)									—	
Engine coolant	NOTE (4)									MA-16. "Changing Engine Coolant"	MA-23. "Changing Engine Coolant"
Engine oil		R	R	R	R	R	R	R	R	MA-20. "Changing Engine Oil"	MA-26. "Changing Engine Oil"
Engine oil filter (Use part No. 15208-65F01, 15208-9E000 or equiv.)		R	R	R	R	R	R	R	R	MA-20. "Changing Oil Filter"	—
Engine oil filter (Use part No. 15208-9E000 or equiv.)		R	R	R	R	R	R	R	R	—	MA-27. "Changing Oil Filter"
Spark plugs (Double PLATINUM-TIPPED type)		Replace every 105,000 miles (169,000 km)								MA-21. "Changing Spark Plugs (Double Platinum - Tipped Type)"	MA-27. "Changing Spark Plugs (Double Platinum - Tipped Type)"
Intake and exhaust valve clearance	NOTE (5)*									EM-35. "Valve Clearance"	—

Abbreviations: R = Replace. I = Inspect. Correct or replace if necessary. []: At the mileage intervals only

MAINTENANCE OPERATION		MAINTENANCE INTERVAL								Reference Section - Page or - Content Title	
Perform at number of miles, kilometers or months, whichever comes first.	Miles x 1,000 (km x 1,000)	33.75 (54)	37.5 (60)	41.25 (66)	45 (72)	48.75 (78)	52.5 (84)	56.25 (90)	60 (96)	QG18DE	QR25DE
	Months	27	30	33	36	39	42	45	48		
Drive belt	NOTE (1)								I*	MA-16. "Checking Drive Belts"	MA-23. "Checking Drive Belts"
Air cleaner filter	NOTE (2)								[R]	MA-19. "Changing Air Cleaner Filter"	MA-26. "Changing Air Cleaner Filter"
EVAP vapor lines									I*	MA-22. "Checking EVAP Vapor Lines"	MA-28. "Checking EVAP Vapor Lines"

PERIODIC MAINTENANCE

MAINTENANCE OPERATION		MAINTENANCE INTERVAL								Reference Section - Page or - Content Title		
		33.75 (54) 27	37.5 (60) 30	41.25 (66) 33	45 (72) 36	48.75 (78) 39	52.5 (84) 42	56.25 (90) 45	60 (96) 48	QG18DE	QR25DE	
Perform at number of miles, kilometers or months, whichever comes first.	Miles x 1,000 (km x 1,000) Months									I*	MA-19, "Checking Fuel Lines"	MA-25, "Checking Fuel Lines"
Fuel lines												
Fuel filter	NOTE (3)										—	
Engine coolant	NOTE (4)									R*	MA-16, "Changing Engine Coolant"	MA-23, "Changing Engine Coolant"
Engine oil		R	R	R	R	R	R	R	R		MA-20, "Changing Engine Oil"	MA-26, "Changing Engine Oil"
Engine oil filter (Use part No. 15208-65F01, 15208-9E000 or equiv.)		R	R	R	R	R	R	R	R		MA-20, "Changing Oil Filter"	—
Engine oil filter (Use part No. 15208-9E000 or equiv.)		R	R	R	R	R	R	R	R		—	MA-27, "Changing Oil Filter"
Spark plugs (Double PLATINUM-TIPPED type)		Replace every 105,000 miles (169,000 km)									MA-21, "Changing Spark Plugs (Double Platinum - Tipped Type)"	MA-27, "Changing Spark Plugs (Double Platinum - Tipped Type)"
Intake and exhaust valve clearance	NOTE (5)*										EM-35, "Valve Clearance"	—

NOTE:

- (1) After 60,000 miles (96,000 km) or 48 months, inspect every 15,000 miles (24,000 km) or 12 months. Replace the drive belt if found damaged or if the auto belt tensioner reading (for QR25DE engine) reaches the maximum limit.
- (2) If operating mainly in dusty conditions, more frequent maintenance may be required.
- (3) Maintenance-free item.
- (4) After 60,000 miles (96,000 km) or 48 months, replace every 30,000 miles (48,000 km) or 24 months.
- (5) If valve noise increases, inspect valve clearance.

Maintenance items and intervals with "*" are recommended by NISSAN for reliable vehicle operation. The owner need not perform such maintenance in order to maintain the emission warranty or manufacturer recall liability. Other maintenance items and intervals are required.

A
B
C
D
E
F
G
H
I
J
K

MA

M

PERIODIC MAINTENANCE

CHASSIS AND BODY MAINTENANCE

Abbreviations: R = Replace. I = Inspect. Correct or replace if necessary. L = Lubricate.

MAINTENANCE OPERATION		MAINTENANCE INTERVAL								Reference Section - Page or - Content Title
Perform at number of miles, kilometers or months, whichever comes first.	Miles x 1,000 (km x 1,000) Months	3.75 (6) 3	7.5 (12) 6	11.25 (18) 9	15 (24) 12	18.75 (30) 15	22.5 (36) 18	26.25 (42) 21	30 (48) 24	
Brake lines & cables					I				I	MA-32
Brake pads, rotors, drums & linings (QG18DE)			I		I		I		I	MA-32 and MA-33
Brake pads & rotors (QR25DE)			I		I		I		I	MA-32
Manual transaxle oil or automatic transaxle fluid	NOTE (1)				I				I	MA-29 or MA-31
Steering gear & linkage, axle & suspension parts			I		I		I		I	MA-34 , MA-35
Tire rotation	NOTE (2)									MA-31
Front drive shaft boots			I		I		I		I	MA-36
Exhaust system			I		I		I		I	MA-29
In-cabin microfilter					R				R	MTC-77

Abbreviations: R = Replace. I = Inspect. Correct or replace if necessary. L = Lubricate.

MAINTENANCE OPERATION		MAINTENANCE INTERVAL								Reference Section - Page or - Content Title
Perform at number of miles, kilometers or months, whichever comes first.	Miles x 1,000 (km x 1,000) Months	33.75 (54) 27	37.5 (60) 30	41.25 (66) 33	45 (72) 36	48.75 (78) 39	52.5 (84) 42	56.25 (90) 45	60 (96) 48	
Brake lines & cables					I				I	MA-32
Brake pads, rotors, drums & linings (QG18DE)			I		I		I		I	MA-32 and MA-33
Brake pads & rotors (QR25DE)			I		I		I		I	MA-32
Manual transaxle oil or automatic transaxle fluid	NOTE (1)				I				I	MA-29 or MA-31
Steering gear & linkage, axle & suspension parts			I		I		I		I	MA-34 , MA-35
Tire rotation	NOTE (2)									MA-31
Front drive shaft boots			I		I		I		I	MA-36
Exhaust system			I		I		I		I	MA-29
In-cabin microfilter					R				R	MTC-77

NOTE:

- (1) If towing a trailer, using a camper or a car-top carrier, or driving on rough or muddy roads, change (not just inspect) oil (exc. LSD) at every 30,000 miles (48,000 km) or 24 months, and change LSD gear oil every 15,000 miles (24,000 km) or 12 months.
- (2) Refer to "Tire rotation" under the "GENERAL MAINTENANCE" heading earlier in this section.

PERIODIC MAINTENANCE

ELS0001M

Schedule 2 EMISSION CONTROL SYSTEM MAINTENANCE

Abbreviations: R = Replace. I = Inspect. Correct or replace if necessary. []: At the mileage intervals only

MAINTENANCE OPERATION		MAINTENANCE INTERVAL								Reference Section - Page or - Content Title	
Perform at number of miles, kilometers or months, whichever comes first.	Miles x 1,000 (km x 1,000) Months	7.5 (12) 6	15 (24) 12	22.5 (36) 18	30 (48) 24	37.5 (60) 30	45 (72) 36	52.5 (84) 42	60 (96) 48	QG18DE	QR25DE
Drive belt	NOTE (1)								I*	MA-16. "Checking Drive Belts"	MA-23. "Checking Drive Belts"
Air cleaner filter					[R]				[R]	MA-19. "Changing Air Cleaner Filter"	MA-26. "Changing Air Cleaner Filter"
EVAP vapor lines					I*				I*	MA-22. "Checking EVAP Vapor Lines"	MA-28. "Checking EVAP Vapor Lines"
Fuel lines					I*				I*	MA-19. "Checking Fuel Lines"	MA-25. "Checking Fuel Lines"
Fuel filter	NOTE (2)									—	
Engine coolant	NOTE (3)								R*	MA-16. "Changing Engine Coolant"	MA-23. "Changing Engine Coolant"
Engine oil		R	R	R	R	R	R	R	R	MA-20. "Changing Engine Oil"	MA-26. "Changing Engine Oil"
Engine oil filter (Use part No. 15208-65F01, 15208-9E000 or equivalent.)		R	R	R	R	R	R	R	R	MA-20. "Changing Oil Filter"	—
Engine oil filter (Use part No. 15208-9E000 or equiv.)		R	R	R	R	R	R	R	R	—	MA-26. "Changing Engine Oil"
Spark plugs (Double PLATINUM-TIPPED type)		Replace every 105,000 miles (169,000 km)								MA-21. "Changing Spark Plugs (Double Platinum - Tipped Type)"	MA-27. "Changing Spark Plugs (Double Platinum - Tipped Type)"
Intake and exhaust valve clearance)	NOTE (4)*									EM-35. "Valve Clearance"	—

NOTE:

Replace the drive belt if found damaged or if the auto belt tensioner reading reaches the maximum limit.

- (1) After 60,000 miles (96,000 km) or 48 months, inspect every 15,000 miles (24,000 km) or 12 months. Replace the drive belt if found damaged or if the auto belt tensioner reading (for QR25DE engine) reaches the maximum limit.
- (2) Maintenance-free item.
- (3) After 60,000 miles (96,000 km) or 48 months, replace every 30,000 miles (48,000 km) or 24 months.
- (4) If valve noise increases, inspect valve clearance.

PERIODIC MAINTENANCE

Maintenance items and intervals with “*” are recommended by NISSAN for reliable vehicle operation. The owner need not perform such maintenance in order to maintain the emission warranty or manufacturer recall liability. Other maintenance items and intervals are required.

CHASSIS AND BODY MAINTENANCE

Abbreviations: R = Replace. I = Inspect. Correct or replace if necessary. L = Lubricate.

MAINTENANCE OPERATION		MAINTENANCE INTERVAL								Reference Section - Page or - Content Title
Perform at number of miles, kilometers or months, whichever comes first.	Miles x 1,000 (km x 1,000) Months	7.5 (12) 6	15 (24) 12	22.5 (36) 18	30 (48) 24	37.5 (60) 30	45 (72) 36	52.5 (84) 42	60 (96) 48	
Brake lines & cables			I		I		I		I	MA-32
Brake pads, rotors, drums & linings (QG18DE)			I		I		I		I	MA-32 , MA-33
Brake pads & rotors (QR25DE)			I		I		I		I	MA-32
Manual transaxle oil or automatic transaxle fluid			I		I		I		I	MA-29 or MA-31
Steering gear & linkage, axle & suspension parts					I				I	MA-34 , MA-35
Tire rotation	NOTE (1)									MA-31
Front drive shaft boots			I		I		I		I	MA-36
Exhaust system					I				I	MA-29
In-cabin microfilter			R		R		R		R	MTC-77

NOTE:

- (1) Refer to “Tire rotation” under the “GENERAL MAINTENANCE” heading earlier in this section.

RECOMMENDED FLUIDS AND LUBRICANTS

PFP:00000

ELS000IN

RECOMMENDED FLUIDS AND LUBRICANTS

Fluids and Lubricants

QG18DE		Capacity (Approximate)			Recommended Fluids/Lubricants
		US measure	Imp measure	Liter	
Engine oil Drain and refill	With oil filter change	2 7/8 qt	2 3/8 qt	2.7	<ul style="list-style-type: none"> ● API Certification Mark*1 ● API grade SL, Energy Conserving*1 ● ILSAC grade GF-III*1
	Without oil fil- ter change	2 5/8 qt	2 1/4 qt	2.5	
Dry engine (engine overhaul)		3 1/4 qt	2 3/4 qt	3.1	
Cooling system (with reservoir)	M/T	7 1/8 qt	5 7/8 qt	6.7	Genuine NISSAN Long Life Anti-freeze coolant or equivalent
	A/T	7 qt	5 7/8 qt	6.6	
Manual transaxle fluid	RS5F70A	3 1/8 qt	2 5/8 qt	3.0	Genuine NISSAN Manual Transmission Fluid (MTF) HQ multi 75W-85
Automatic tran- saxle fluid	RE4F03B	7 3/8 qt	6 1/8 qt	7.0	NISSAN Matic "D" (Continental U.S. and Alaska) or Canada NISSAN Automatic Transmission Fluid*2
Power steering fluid (PSF)		2 1/8 pt	1 3/4 pt	1.0	Genuine NISSAN PSF or equivalent*4
Brake and clutch fluid		—	—	—	Genuine NISSAN Super Heavy Duty Brake Fluid*3 or equivalent DOT 3 (US FMVSS No. 116)
Multi-purpose grease		—	—	—	NLGI No. 2 (Lithium soap base)
Windshield washer fluid		—	—	—	Genuine NISSAN Windshield Washer Concentrate Cleaner & Anti-freeze or equivalent
Air conditioning system refrigerant		0.99 - 1.21 lb	0.99 - 1.21 lb	0.45 - 0.55 kg	HFC-134a (R-134a)*5
Air conditioning system lubricant		6.1 fl oz	6.3 fl oz	180 mℓ	Genuine NISSAN A/C System Lubricant Type R or equivalent*5

*1: For further details, see "SAE Viscosity Number".

*2: DEXRON™ III / MERCON™, or equivalent may also be used. Outside the continental United States and Alaska contact a NISSAN dealership for more information regarding suitable fluids, including recommended brand(s) of DEXRON™ III / MERCON™ Automatic Transmission Fluid.

*3: Available in mainland U.S.A. through your NISSAN dealer.

*4: Genuine NISSAN PSF, Canada NISSAN Automatic Transmission Fluid, DEXRON™ III / MERCON™ or equivalent ATF may also be used.

*5: For further details, see "Air conditioner specification label".

QR25DE		Capacity (Approximate)			Recommended Fluids/Lubricants
		US measure	Imp measure	Liter	
Engine oil Drain and refill	With oil filter change	4 1/8 qt	3 3/8 qt	3.9	<ul style="list-style-type: none"> ● API Certification Mark*1 ● API grade SL, Energy Conserving*1 ● ILSAC grade GF-III*1
	Without oil fil- ter change	3 7/8 qt	3 1/4 qt	3.7	
Dry engine (engine overhaul)		4 5/8 qt	3 7/8 qt	4.4	
Cooling system (with reservoir)	M/T	7 3/16 qt	6 qt	6.8	Genuine NISSAN Long Life Anti-freeze coolant or equivalent
	A/T	7 1/8 qt	5 7/8 qt	6.7	
Manual transaxle fluid	RS5F51A RS6F51H	2 3/8 qt	2 qt	2.3	Genuine NISSAN Manual Transmission Fluid (MTF) HQ multi 75W-85
Automatic tran- saxle fluid	RE4F04B	9 qt	7.5 qt	8.5	NISSAN Matic "D" (Continental U.S. and Alaska) or Canada NISSAN Automatic Transmission Fluid*2
Power steering fluid (PSF)		2 1/8 pt	1 3/4 pt	1.0	Genuine NISSAN PSF or equivalent*4

RECOMMENDED FLUIDS AND LUBRICANTS

QR25DE	Capacity (Approximate)			Recommended Fluids/Lubricants
	US measure	Imp measure	Liter	
Brake and clutch fluid	—	—	—	Genuine NISSAN Super Heavy Duty Brake Fluid*3 or equivalent DOT 3 (US FMVSS No. 116)
Multi-purpose grease	—	—	—	NLGI No. 2 (Lithium soap base)
Windshield washer fluid	—	—	—	Genuine NISSAN Windshield Washer Concentrate Cleaner & Anti-freeze or equivalent
Air conditioning system refrigerant	0.99 - 1.21 lb	0.99 - 1.21 lb	0.45 - 0.55 kg	HFC-134a (R-134a)*5
Air conditioning system lubricant	6.1 fl oz	6.3 fl oz	180 m ℓ	Genuine NISSAN A/C System Lubricant Type R or equivalent*5

*1: For further details, see "SAE Viscosity Number".

*2: DEXRON™ III / MERCON™, or equivalent may also be used. Outside the continental United States and Alaska contact an authorized NISSAN dealership for more information regarding suitable fluids, including recommended brand(s) of DEXRON™ III / MERCON™ Automatic Transmission Fluid.

*3: Available in mainland U.S.A. through your authorized NISSAN dealer.

*4: Genuine NISSAN PSF, Canada NISSAN Automatic Transmission Fluid, DEXRON™ III / MERCON™ or equivalent ATF may also be used.

*5: For further details, see "Air conditioner specification label".

SAE Viscosity Number

ELS00010

SAE 5W-30 viscosity oil is preferred for all temperatures. SAE 10W-30 and 10W-40 viscosity oil may be used if the ambient temperature is above -18°C (0°F).

NOTE:

The use of a 5W-30 viscosity oil may increase fuel economy.

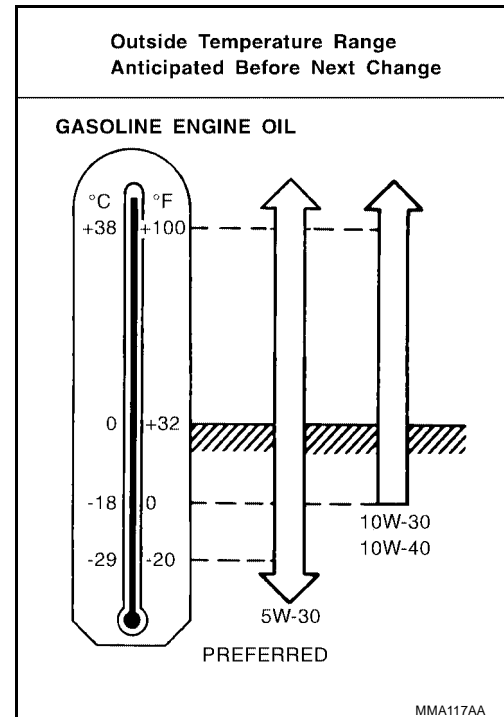

Anti-freeze Coolant Mixture Ratio

ELS0001P

The engine cooling system is filled at the factory with a high-quality, year-round, long life, anti-freeze coolant solution. The anti-freeze solution contains rust and corrosion inhibitors, so additional cooling system additives are not necessary.

Protection for outside temperature down to:		Genuine NISSAN Long Life Anti-freeze coolant or equivalent	Demineralized water or distilled water
°C	°F		
-35°	-30°	50%	50%

RECOMMENDED FLUIDS AND LUBRICANTS

CAUTION:

- When adding or replacing coolant, be sure to use only a Genuine NISSAN Long Life Anti-freeze coolant or equivalent with the specified mixture ratio.
- The use of other types of coolant solutions may damage the engine cooling system.

A

B

C

D

E

F

G

H

I

J

K

MA

M

Checking Drive Belts

ELS0001Q

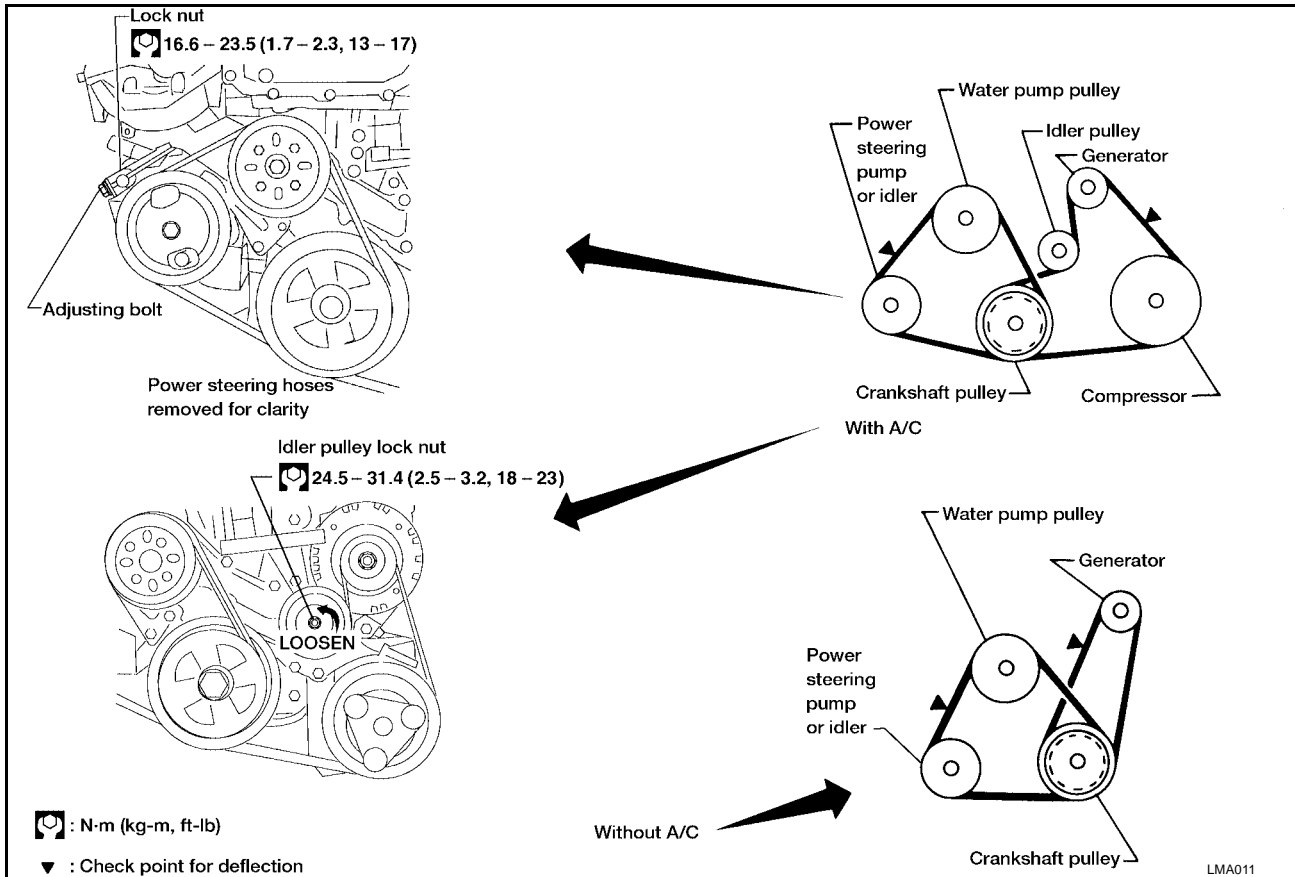

1. Inspect belt for cracks, fraying, wear and oil. If necessary, replace.
2. Inspect drive belt deflection or tension at a point on the belt midway between pulleys. Adjust if belt deflection exceeds the limit or if belt tension is not within specifications.
 - Check belt tension using Belt Tension Gauge BT3373-F or equivalent. Refer to [MA-38, "BELT DEFLECTION AND TENSION"](#).
 - Inspect drive belt deflection or tension when engine is cold.

Changing Engine Coolant

ELS0001R

WARNING:

To avoid the danger of being scalded, never change the coolant when the engine is hot.

DRAINING ENGINE COOLANT

1. Set climate control system as follows to prevent coolant from remaining in the system.
 - Turn ignition switch "ON" and set temperature controller to maximum hot position.
 - Wait 10 seconds before turning ignition switch "OFF".

ENGINE MAINTENANCE (QG18DE ENGINE)

- Open radiator drain plug at the bottom of the radiator, and remove radiator filler cap.

CAUTION:

Be careful not to allow coolant to contact drive belts.

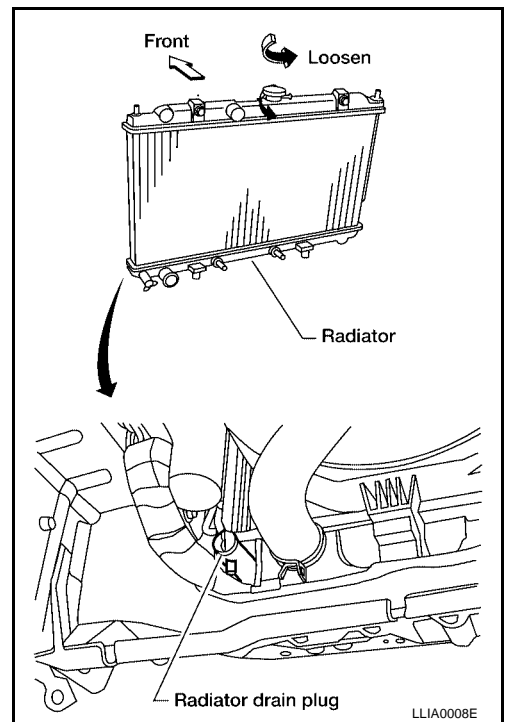

- Remove cylinder block drain plug and air relief plug.

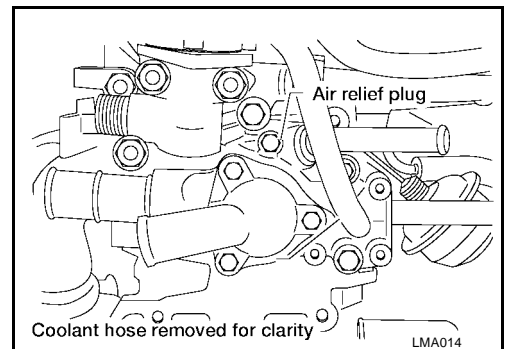
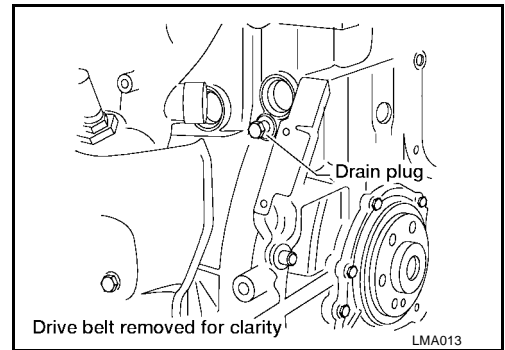

- Check drained coolant for contaminants such as rust, corrosion or discoloration. If contaminated, flush engine cooling system. Refer to [MA-18, "FLUSHING COOLING SYSTEM"](#).

REFILLING ENGINE COOLANT

- Close radiator drain plug. Install the reservoir tank and cylinder block drain plug, if removed for a total system drain for engine removal or repair.
 - The radiator must be completely empty of coolant and water.
 - Apply sealant to the threads of the cylinder block drain plugs. Use Genuine High Performance Thread Sealant or equivalent. Refer to [GI-44, "RECOMMENDED CHEMICAL PRODUCTS AND SEALANTS"](#).

Cylinder block drain plug : 34.3 - 44.1 N·m (3.5 - 4.5 kg·m, 26 - 32 ft·lb)

ENGINE MAINTENANCE (QG18DE ENGINE)

- If disconnected, reattach the upper radiator hose at the engine side.
- Set the vehicle heater controls to the full HOT and heater ON position. Turn the vehicle ignition ON with the engine OFF as necessary to activate the heater mode.
- Install the Tool by installing the radiator cap adapter onto the radiator neck opening. Then attach the gauge body assembly with the refill tube and the venturi assembly to the radiator cap adapter.
- Insert the refill hose into the coolant mixture container that is placed at floor level. Make sure the ball valve is in the closed position.

- Use Genuine NISSAN Long Life Anti-freeze coolant or equivalent, mixed 50/50 with distilled water or demineralized water. Refer to [MA-14, "Anti-freeze Coolant Mixture Ratio"](#).

Coolant capacity (without reservoir tank)

M/T : 6.0 ℓ (6 3/8 US qt, 5 1/4 Imp qt)

A/T : 5.9 ℓ (6 1/4 US qt, 5 1/4 Imp qt)

Reservoir tank capacity : 0.7 ℓ (3/4 US qt, 5/8 Imp qt)
(for MAX level)

- Install an air hose to the venturi assembly, the air pressure must be within specification.

Compressed air supply pressure : 5.7 - 8.5 kPa (5.6 - 8.4 kg/cm², 80 - 120 psi)

CAUTION:

The compressed air supply must be equipped with an air dryer.

- The vacuum gauge will begin to rise and there will be an audible hissing noise. During this process open the ball valve on the refill hose slightly. Coolant will be visible rising in the refill hose. Once the refill hose is full of coolant, close the ball valve. This will purge any air trapped in the refill hose.
- Continue to draw the vacuum until the gauge reaches 28 inches of vacuum. The gauge may not reach 28 inches in high altitude locations, refer to the vacuum specifications based on the altitude above sea level.

Altitude above sea level	Vacuum gauge reading
0 - 100 m (328 ft)	: 28 inches of vacuum
300 m (984 ft)	: 27 inches of vacuum
500 m (1,641 ft)	: 26 inches of vacuum
1,000 m (3,281 ft)	: 24 - 25 inches of vacuum

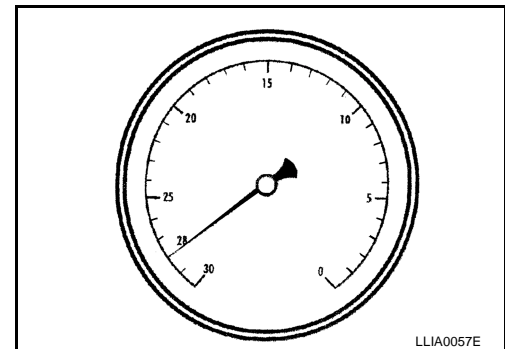
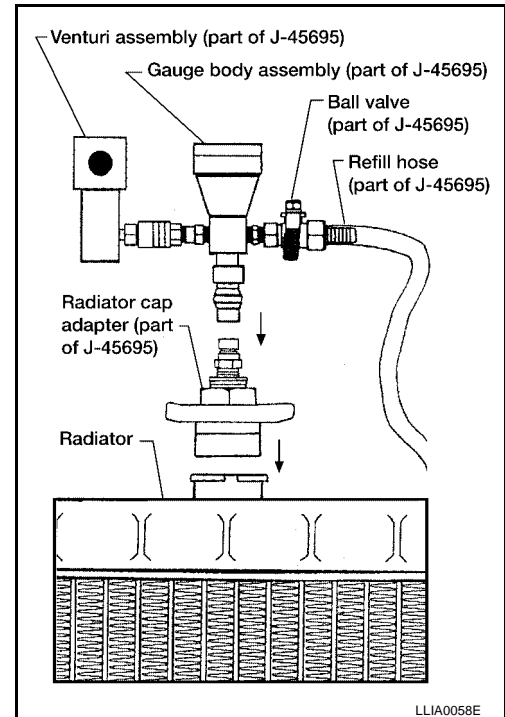

- When the vacuum gauge has reached the specified amount, disconnect the air hose and wait 20 seconds to see if the system loses any vacuum. If the vacuum level drops, perform any necessary repairs to the system and repeat steps 6 - 8 to bring the vacuum to the specified amount. Recheck for any leaks.
- Place the coolant container (with the refill hose inserted) at the same level as the top of the radiator. Then open the ball valve on the refill hose so the coolant will be drawn up to fill the cooling system. The cooling system is full when the vacuum gauge reads zero.

CAUTION:

Do not allow the coolant container to get too low when filling, to avoid air from being drawn into the cooling system.

- Remove the Tool from the radiator neck opening.
- Fill the cooling system reservoir tank to the specified level and install the radiator cap. Run the engine to warm up the cooling system and top up the system as necessary.

FLUSHING COOLING SYSTEM

- Open air relief plug.

ENGINE MAINTENANCE (QG18DE ENGINE)

2. Fill radiator with water until water spills from the air relief hole, then close air relief plug. Fill radiator and reservoir tank with water and reinstall radiator cap.
3. Run engine and warm it up to normal operating temperature.
4. Rev engine two or three times under no-load.
5. Stop engine and wait until it cools down.
6. Drain water.
7. Repeat steps 1 through 6 until clear water begins to drain from radiator.

Checking Fuel Lines

ELS0001S

- Inspect fuel lines and tank for improper attachment, leaks, cracks, damage, loose connections, chafing or deterioration.

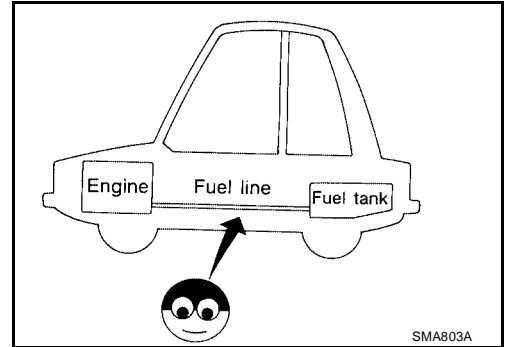

- If necessary, repair or replace faulty parts.

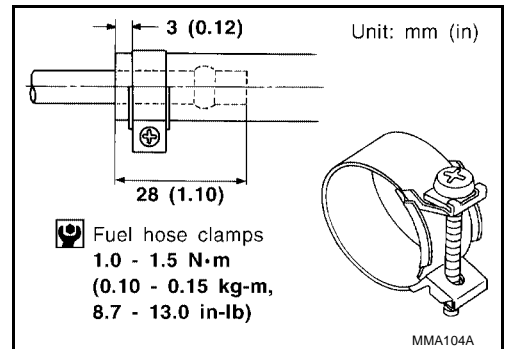

Changing Air Cleaner Filter

ELS0001T

Unfasten clamps to change air cleaner filter.

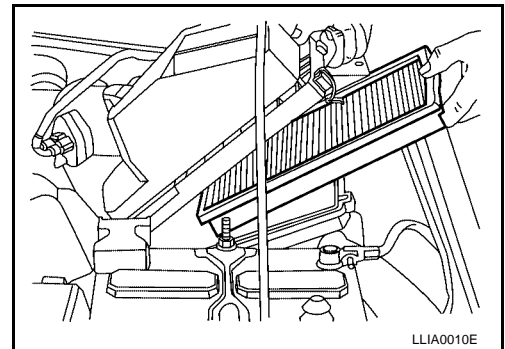

A
B
C
D
E
F
G
H
I
J
K
MA
M

ENGINE MAINTENANCE (QG18DE ENGINE)

ELS000IU

Changing Engine Oil

WARNING:

- Be careful not to burn yourself, as the engine oil is hot.
 - Prolonged and repeated contact with used engine oil may cause skin cancer; try to avoid direct skin contact with used oil. If skin contact is made, wash thoroughly with soap or hand cleaner as soon as possible.
1. Warm up engine, and check for oil leakage from engine components.
 2. Stop engine.
 3. Remove drain plug and oil filler cap.
 4. Drain oil and refill with new engine oil.

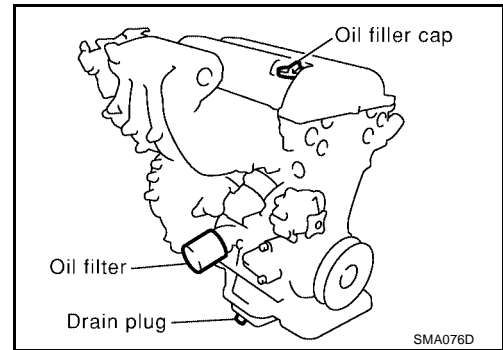

Oil pan drain plug : 29 - 39 N·m (3.0 - 4.0 kg·m, 22 - 29 ft·lb)

Oil Specification and Viscosity

- Refer to [MA-13, "Fluids and Lubricants"](#).

Oil Capacity (Approximate)

Unit: ℓ (US qt., Imp qt.)

Drain and refill	With oil filter change	2.7 (2 7/8, 2 3/8)
	Without oil filter change	2.5 (2 5/8, 2 1/4)
Dry engine (engine overhaul)		3.1 (3 1/4, 2 3/4)

CAUTION:

- Be sure to clean drain plug and install with new washer.

Oil pan drain plug : 29 - 39 N·m (3.0 - 4.0 kg·m, 22 - 29 ft·lb)

- The refill capacity depends on the oil temperature and drain time. Use these specifications for reference only.
 - Always use the dipstick to determine when the proper amount of oil is in the engine.
5. Warm up engine and check area around drain plug and oil filter for oil leakage.
 6. Stop engine.
 7. Check oil level.

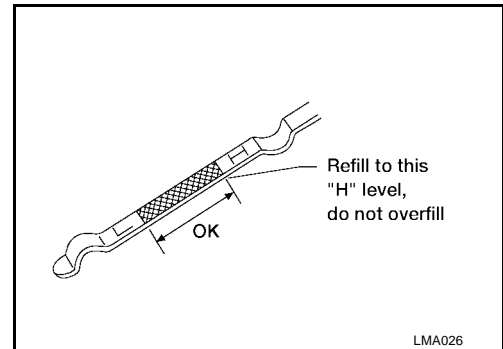

Changing Oil Filter

1. Remove the oil filter using Tool as shown.

WARNING:

Be careful not to burn yourself, as the engine and engine oil are hot.

NOTE:

The filter is a full-flow cartridge type and is provided with a relief valve.

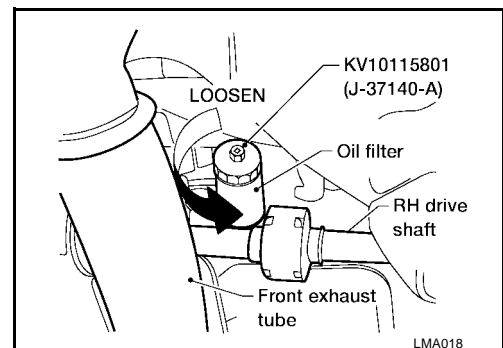

ELS000IV

ENGINE MAINTENANCE (QG18DE ENGINE)

- Clean oil filter mounting surface on cylinder block. Coat rubber seal of new oil filter with engine oil.

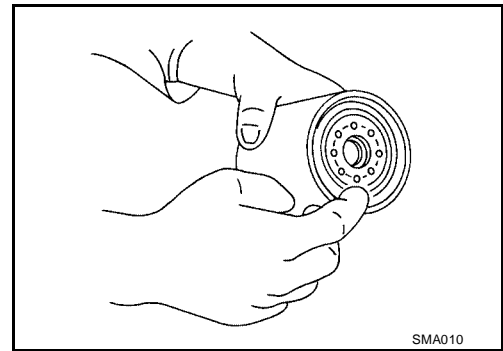

SMA010

- Screw in the oil filter until a slight resistance is felt, then tighten an additional 2/3 turn.

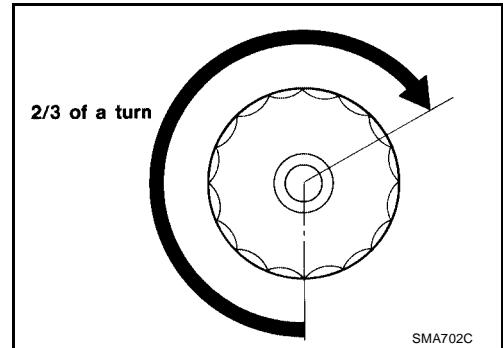

SMA702C

- Add engine oil. Refer to [MA-20, "Changing Engine Oil"](#) .
 - Clean excess oil from engine.

Changing Spark Plugs (Double Platinum - Tipped Type)

ELS000IW

- Disconnect ignition coil harness connectors.
- Remove ignition coils.

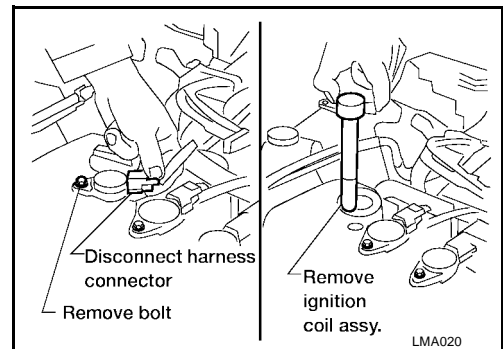

LMA020

- Remove spark plugs with spark plug socket.

Spark Plug Types

Hot type	PLFR4A-11
Standard type	PLFR5A-11
Cold type	PLFR6A-11

Spark plug gap (nominal) : 1.1 mm (0.043 in)

- The standard type spark plug is suitable for normal driving conditions.
- The hot type spark plug is suitable when fouling occurs with the standard type spark plug under conditions such as:
 - Frequent engine starts
 - Low ambient temperatures
- The cold type spark plug is suitable when spark knock occurs with the standard type spark plug under conditions such as:
 - Extended highway driving
 - Frequent high engine revolution

ENGINE MAINTENANCE (QG18DE ENGINE)

- If plug is covered with carbon, a spark plug cleaner may be used as specified.

CAUTION:

Do not use wire brush for cleaning. If plug is covered with carbon, spark plug cleaner may be used.

Cleaner air pressure : Less than 588 kPa (6 kg/cm², 85 psi)

Cleaning time : less than 20 seconds

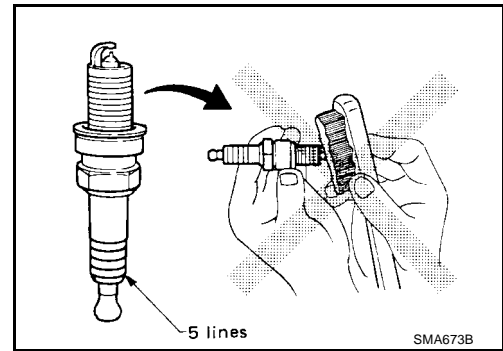

- Checking and adjusting plug gap is not required between change intervals.

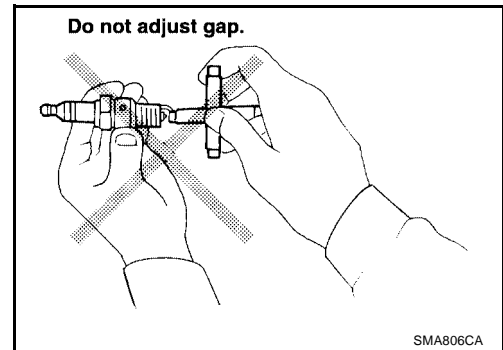

4. Install the spark plugs.

Spark plug : 20 - 29 N·m (2.0 - 3.0 kg·m, 14 - 22 ft·lb)

5. Install the ignition coils and ignition wires.

Ignition coil : 3.8 - 5.0 N·m (0.38 - 0.51 kg·m, 33 - 44 in·lb)

Checking EVAP Vapor Lines

ELS0001X

1. Visually inspect EVAP vapor lines for improper attachment, cracks, damage, loose connections, chafing or deterioration.
2. Inspect vacuum relief valve of fuel tank filler cap for clogging, sticking, etc. Refer to [EC-586, "FUEL TANK VACUUM RELIEF VALVE \(BUILT INTO FUEL FILLER CAP\)"](#) (QG18DE ULEV), [EC-1208, "FUEL TANK VACUUM RELIEF VALVE \(BUILT INTO FUEL FILLER CAP\)"](#) (QG18DE SULEV).

ENGINE MAINTENANCE (QR25DE ENGINE)

ENGINE MAINTENANCE (QR25DE ENGINE)

PFP:10001

Checking Drive Belts

ELS0001Y

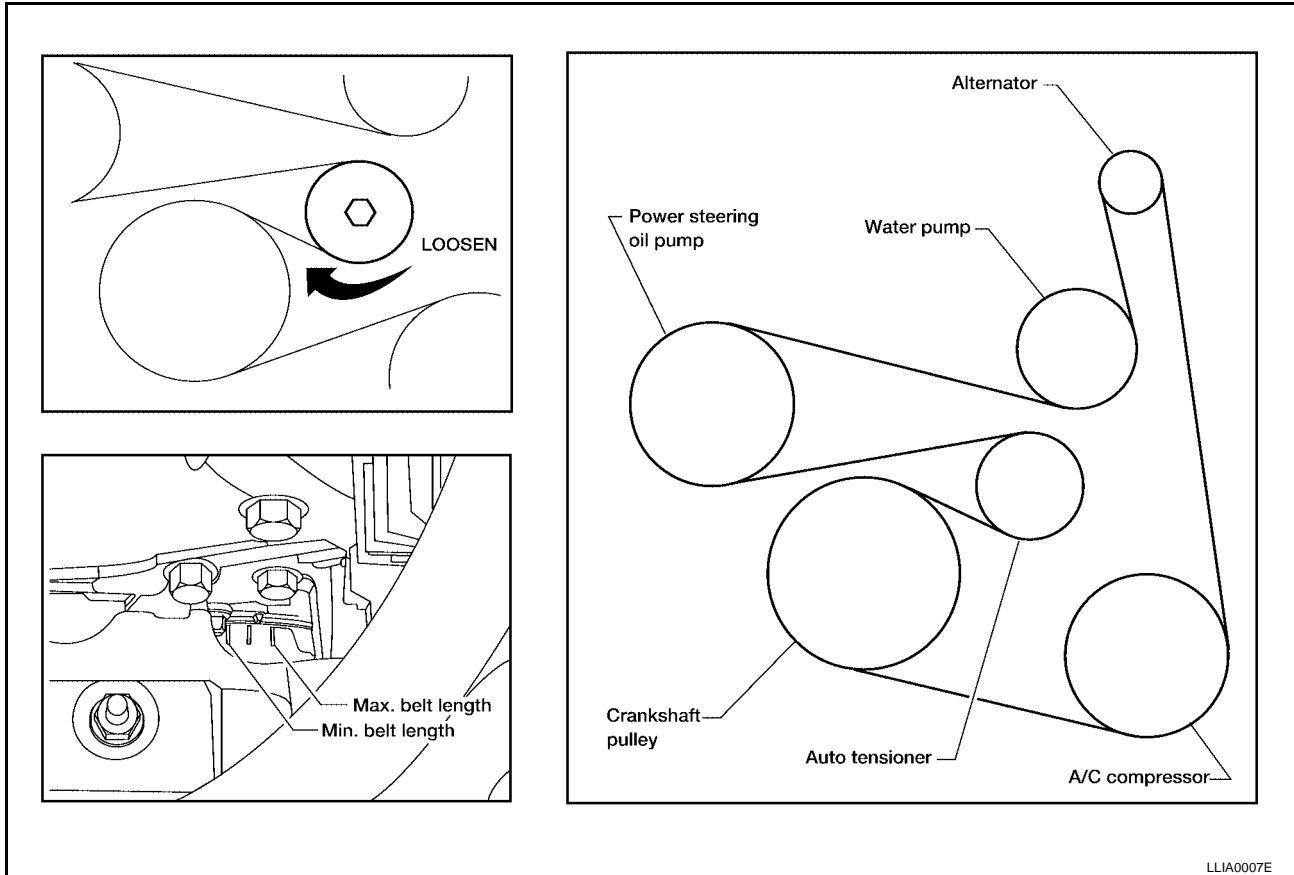

LLIA0007E

WARNING:

Be sure to perform when the engine is stopped.

- Make sure that indicator (single line notch) of each automatic tensioner is within the allowable working range (between three notches).

NOTE:

- Check the automatic tensioner indicator when the engine is cold.
- The indicator notch is located on the moving side of the tensioner.
- Visually check entire belt for wear, damage or cracks.
- If the indicator is out of allowable working range or belt is damaged, replace the belt.
- Belt tensioning is not necessary, as it is automatically adjusted by auto belt tensioner.

Changing Engine Coolant

ELS0001Z

WARNING:

To avoid the danger of being scalded, never change the coolant when the engine is hot.

DRAINING ENGINE COOLANT

1. Open radiator drain plug at the bottom of the radiator, and remove radiator filler cap.

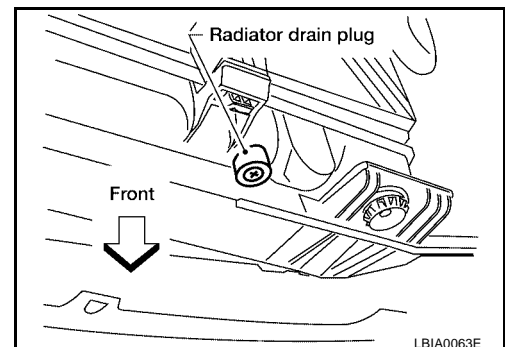

LBIA0063E

A
B
C
D
E
F
G
H
I
J
K
L
M

MA

ENGINE MAINTENANCE (QR25DE ENGINE)

CAUTION:

When draining all the coolant in the system, also perform steps two and three:

2. Remove cylinder block drain plug and air relief plug.

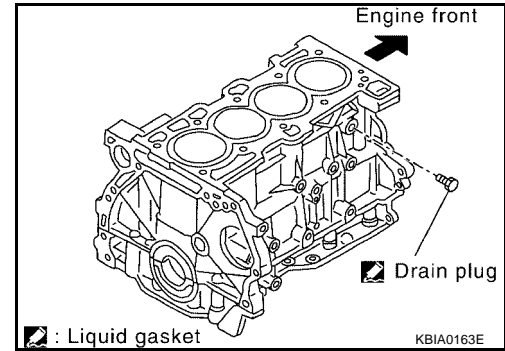

3. Check drained coolant for contaminants such as rust, corrosion or discoloration. If contaminated, flush engine cooling system.
Refer to [MA-25, "FLUSHING COOLING SYSTEM"](#).

REFILLING ENGINE COOLANT

1. Install the radiator drain plug. Install the reservoir tank and cylinder block drain plug, if removed for a total system drain for engine removal or repair.
 - The radiator must be completely empty of coolant and water.
 - Apply sealant to the threads of the cylinder block drain plugs. Use Genuine High Performance Thread Sealant or equivalent. Refer to [GI-44, "RECOMMENDED CHEMICAL PRODUCTS AND SEALANTS"](#).

Radiator drain plug : 7.8 - 11.8 N·m (0.8 - 1.2 kg·m , 69 - 104 in·lb)

Cylinder block drain plug : 34 - 44 N·m (3.5 - 4.5 kg·m, 25 - 33 ft·lb)

2. If disconnected, reattach the upper radiator hose at the engine side.
3. Set the vehicle heater controls to the full HOT and heater ON position. Turn the vehicle ignition ON with the engine OFF as necessary to activate the heater mode.
4. Install the Tool by installing the radiator cap adapter onto the radiator neck opening. Then attach the gauge body assembly with the refill tube and the venturi assembly to the radiator cap adapter.
5. Insert the refill hose into the coolant mixture container that is placed at floor level. Make sure the ball valve is in the closed position.
 - Use Genuine NISSAN Long Life Anti-freeze coolant or equivalent, mixed 50/50 with distilled water or demineralized water. Refer to [MA-14, "Anti-freeze Coolant Mixture Ratio"](#).

Coolant capacity (without reservoir tank)

M/T : 6.1 ℓ (6 1/2 US qt, 5 3/8 Imp qt)

A/T : 6.0 ℓ (6 3/8 US qt, 5 1/4 Imp qt)

**Reservoir tank capacity : 0.7 ℓ (3/4 US qt, 5/8 Imp qt)
(for MAX level)**

6. Install an air hose to the venturi assembly, the air pressure must be within specification.

Compressed air supply pressure : 5.7 - 8.5 kPa (5.6 - 8.4 kg/cm², 80 - 120 psi)

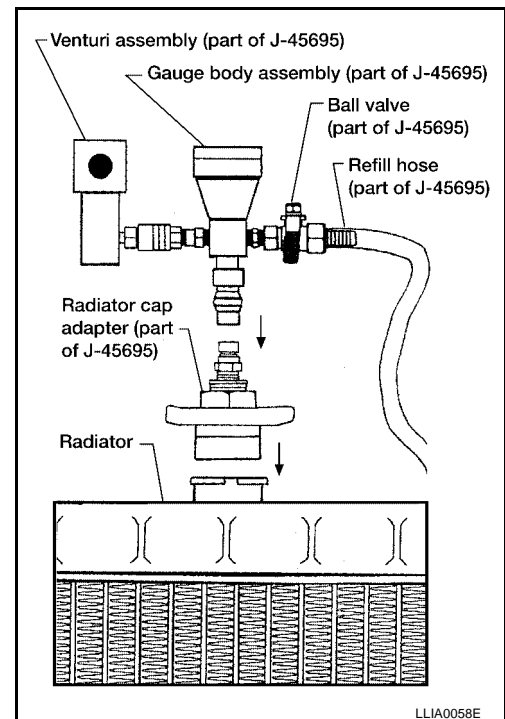

CAUTION:

The compressed air supply must be equipped with an air dryer.

7. The vacuum gauge will begin to rise and there will be an audible hissing noise. During this process open the ball valve on the refill hose slightly. Coolant will be visible rising in the refill hose. Once the refill hose is full of coolant, close the ball valve. This will purge any air trapped in the refill hose.

ENGINE MAINTENANCE (QR25DE ENGINE)

8. Continue to draw the vacuum until the gauge reaches 28 inches of vacuum. The gauge may not reach 28 inches in high altitude locations, refer to the vacuum specifications based on the altitude above sea level.

Altitude Above Sea Level	Vacuum Gauge Reading
0 - 100 m (0 - 328 ft)	28 inches of vacuum
300 m (984 ft)	27 inches of vacuum
500 m (1,641 ft)	26 inches of vacuum
1,000 m (3,281 ft)	24 - 25 inches of vacuum

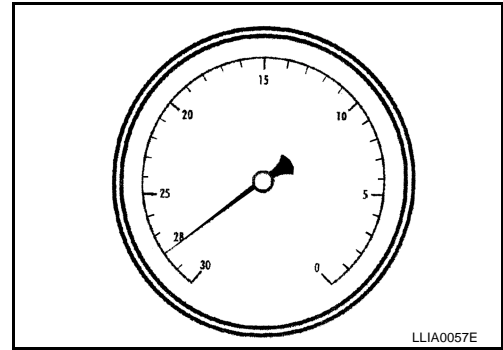

9. When the vacuum gauge has reached the specified amount, disconnect the air hose and wait 20 seconds to see if the system loses any vacuum. If the vacuum level drops, perform any necessary repairs to the system and repeat steps 6 - 8 to bring the vacuum to the specified amount. Recheck for any leaks.
10. Place the coolant container (with the refill hose inserted) at the same level as the top of the radiator. Then open the ball valve on the refill hose so the coolant will be drawn up to fill the cooling system. The cooling system is full when the vacuum gauge reads zero.

CAUTION:

Do not allow the coolant container to get too low when filling, to avoid air from being drawn into the cooling system.

11. Remove the Tool from the radiator neck opening.
12. Fill the cooling system reservoir tank to the specified level and install the radiator cap. Run the engine to warm up the cooling system and top up the system as necessary.

FLUSHING COOLING SYSTEM

1. Fill the radiator and reservoir tank with water and reinstall radiator cap.
2. Run the engine and warm it up to normal operating temperature.
3. Rev the engine two or three times under no-load.
4. Stop the engine and wait until it cools down.
5. Drain the water.
6. Repeat steps 1 through 5 until clear water begins to drain from radiator.

Checking Fuel Lines

- Inspect fuel lines and tank for improper attachment, leaks, cracks, damage, loose connections, chafing or deterioration.

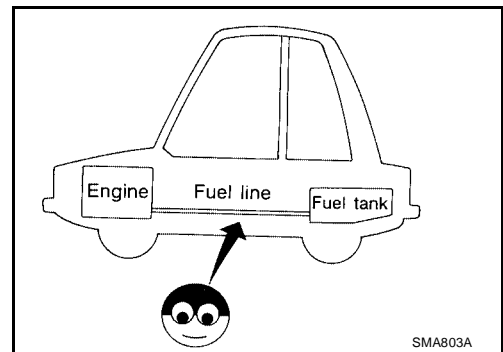

- If necessary, repair or replace faulty parts.

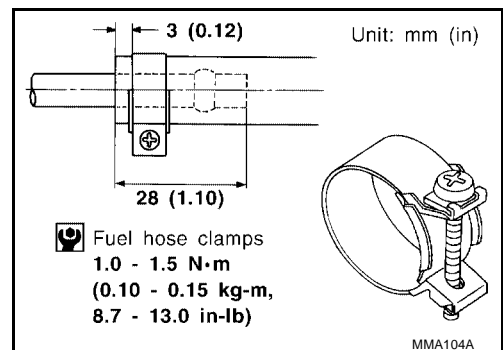

ENGINE MAINTENANCE (QR25DE ENGINE)

Changing Air Cleaner Filter

ELS000J1

Unfasten clamps to change air cleaner filter.

- The viscous paper-type filter does not need cleaning.

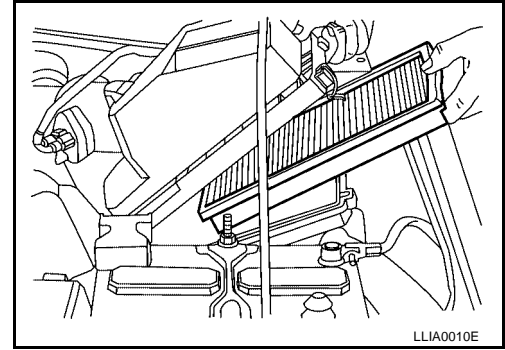

Changing Engine Oil

ELS000J2

WARNING:

- Be careful not to burn yourself, as the engine oil is hot.
 - Prolonged and repeated contact with used engine oil may cause skin cancer; try to avoid direct skin contact with used oil. If skin contact is made, wash thoroughly with soap or hand cleaner as soon as possible.
1. Warm up engine, and check for oil leakage from engine components.
 2. Stop engine.
 3. Remove drain plug and oil filler cap.
 4. Drain oil and refill with new engine oil.

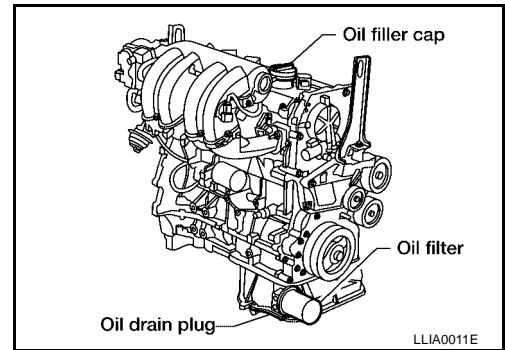

Oil Specification and Viscosity

- Refer to [MA-13, "Fluids and Lubricants"](#).

Oil Capacity (Approximate)

Unit: ℓ (US qt., Imp qt.)

Drain and refill	With oil filter change	3.9 (4 1/8, 3 3/8)
	Without oil filter change	3.7 (3 7/8, 3 1/4)
Dry engine (engine overhaul)		4.4 (4 5/8, 3 7/8)

CAUTION:

- Be sure to clean drain plug and install with new washer.

Oil pan drain plug : 29 - 39 N·m (3.0 - 4.0 kg·m, 22 - 29 ft·lb)

- The refill capacity depends on the oil temperature and drain time. Use these specifications for reference only.
- Always use the dipstick to determine when the proper amount of oil is in the engine.

5. Warm up engine and check area around drain plug and oil filter for oil leakage.
6. Stop engine.
7. Check oil level.

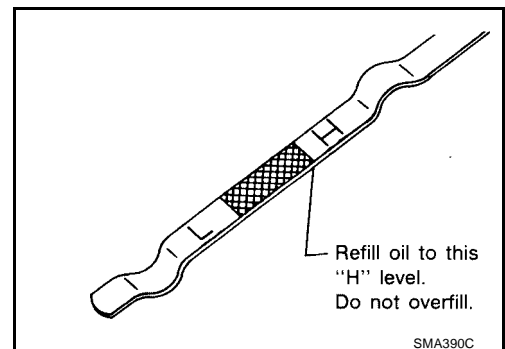

ENGINE MAINTENANCE (QR25DE ENGINE)

Changing Oil Filter

ELS000J3

1. Remove oil filter with Tool.

WARNING:

Be careful not to burn yourself, as the engine and engine oil are hot.

NOTE:

The filter is a full-flow cartridge type and is provided with a relief valve.

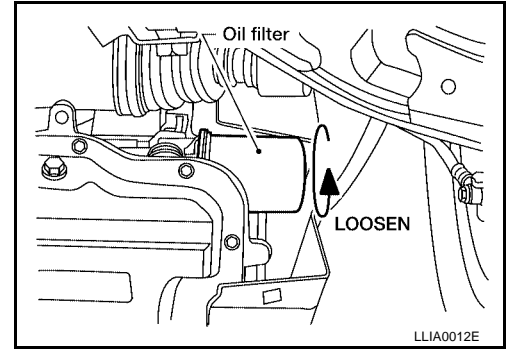

2. Clean oil filter mounting surface on cylinder block. Coat rubber seal of new oil filter with engine oil.

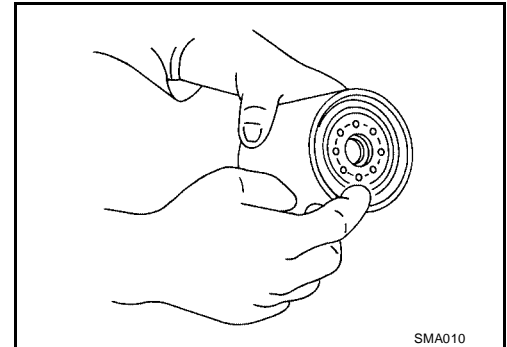

3. Screw in the oil filter until a slight resistance is felt, then tighten an additional 2/3 turn.
4. Add engine oil. Refer to [MA-26, "Changing Engine Oil"](#) .
 - Clean excess oil from engine.

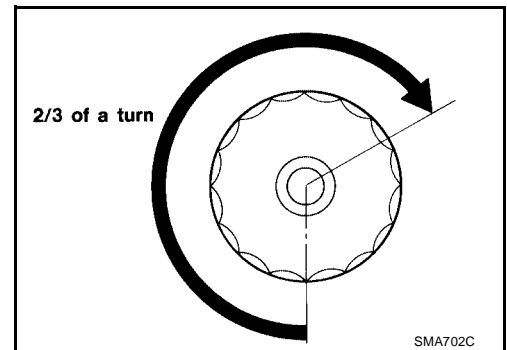

Changing Spark Plugs (Double Platinum - Tipped Type)

ELS000J4

1. Disconnect ignition coil harness connectors.

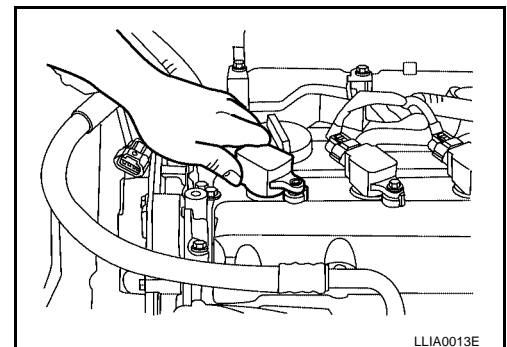

2. Remove ignition coils.
3. Remove spark plugs with spark plug socket.

A
B
C
D
E
F
G
H
I
J
K
MA
M

ENGINE MAINTENANCE (QR25DE ENGINE)

Spark Plug Types

Hot type	PLFR4A-11
Standard type	PLFR5A-11
Cold type	PLFR6A-11

Spark plug gap (nominal) : 1.1 mm (0.043 in)

- Use standard type spark plug for normal condition.
- The hot type spark plug is suitable when fouling occurs with the standard type spark plug under conditions such as:
 - Frequent engine starts
 - Low ambient temperatures
- The cold type spark plug is suitable when spark knock occurs with the standard type spark plug under conditions such as:
 - Extended highway driving
 - Frequent high engine revolution
- If plug tip is covered with carbon, spark plug cleaner may be used.

CAUTION:

Do not use a wire brush for cleaning. If plug tip is covered with carbon, spark plug cleaner may be used.

Cleaner air pressure : Less than 588 kPa (6 kg/cm², 85 psi)

Cleaning time : less than 20 seconds

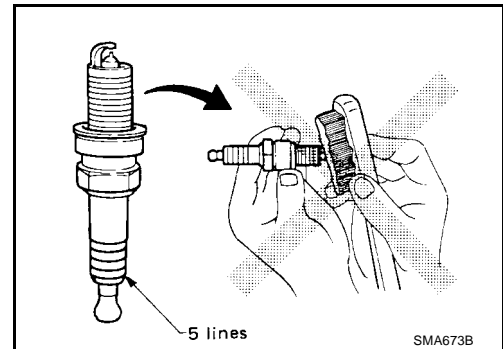

- Checking and adjusting plug gap is not required between change intervals.

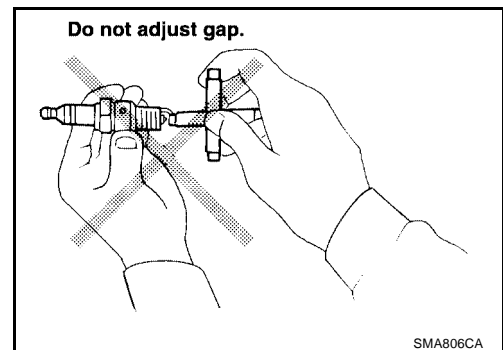

4. Install spark plugs.

Spark plugs : 20 - 29 N-m (2.0 - 3.0 kg-m, 14 - 22 ft-lb)

5. Install ignition coils and reconnect ignition wires according to numbers indicated on them.

Ignition coils : 5.4 - 7.3 N-m (0.55 - 0.73 kg-m, 46 - 64 in-lb)

Checking EVAP Vapor Lines

ELS000J5

1. Visually inspect EVAP vapor lines for improper attachment, cracks, damage, loose connections, chafing or deterioration.
2. Inspect vacuum relief valve of fuel tank filler cap for clogging, sticking, etc. Refer to [EC-1849, "FUEL TANK VACUUM RELIEF VALVE \(BUILT INTO FUEL FULLER CAP\)"](#).

CHASSIS AND BODY MAINTENANCE

PFP:00000

Checking Exhaust System

ELS000J6

Check exhaust pipes, muffler and mounting for improper attachment, leaks, cracks, damage, loose connections, chafing or deterioration.

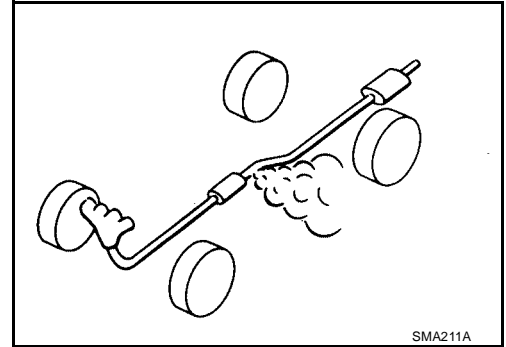

Checking Clutch Fluid Level and Leaks

ELS000J7

If fluid level is extremely low, check clutch system for leaks.

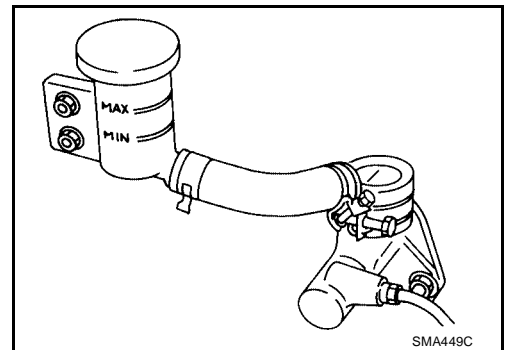

Checking M/T Oil

ELS000J8

1. Check that transaxle oil is not leaking.
2. Check the transaxle oil level is at the correct level as shown.

CAUTION:

Never start the engine while checking the transaxle oil level.

Filler plug

RS5F70A : 10 - 19 N·m (1.0 - 2.0 kg·m, 87 - 173 in·lb)
(QG18DE)

RS5F51A, : 30 - 39 N·m (3.1 - 4.0 kg·m, 23 - 28 lb·ft)
RS6F51H,
(QR25DE)

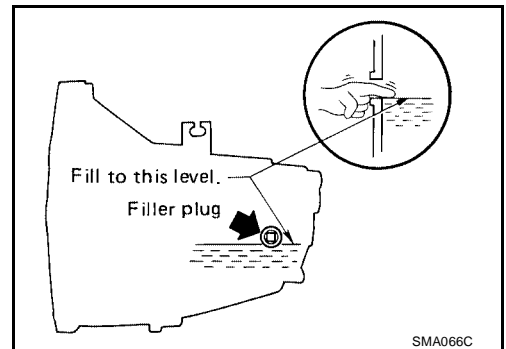

Changing M/T Oil

ELS000J9

1. Drain oil from drain plug and refill with new gear oil.

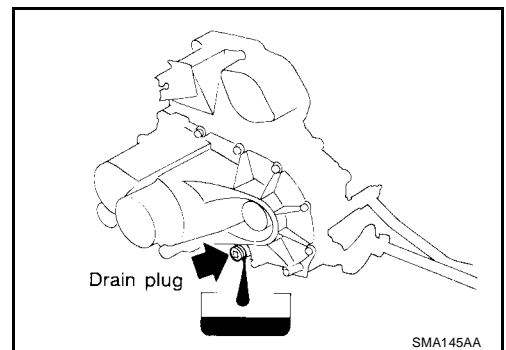

A
B
C
D
E
F
G
H
I
J
K
MA
M

CHASSIS AND BODY MAINTENANCE

2. Check oil level.

Oil grade and viscosity : Refer to [MA-13, "Fluids and Lubricants"](#) .

Capacity : RS5F70A (QG18DE)
3.0 ℓ (3 1/8 US qt, 2 5/8 Imp qt)
RS5F51A, RS6F51H (QR25DE)
2.3 ℓ (2 3/8 US qt, 2 Imp qt)

Drain plug : RS5F70A (QG18DE)
10 - 19 N·m (1.0 - 2.0 kg·m, 87 - 173 in·lb)
RS5F51A, RS6F51H (QR25DE)
30 - 39 N·m (3.1 - 4.0 kg·m, 23 - 28 ft·lb)

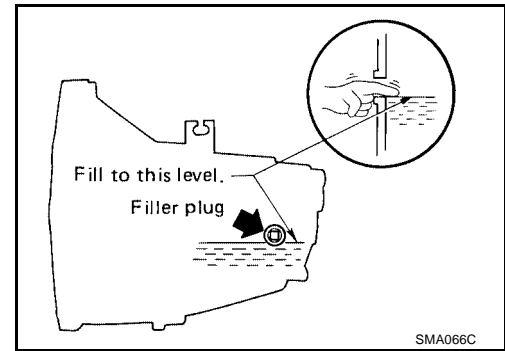

Checking A/T Fluid

ELS000JA

1. Check for any A/T fluid leakage and correct as necessary.
2. Warm up the engine.
3. Before driving, the A/T fluid level can be checked at fluid temperatures of 30° to 50°C (86° to 122°F) using the "COLD" range on dipstick.
 - a. Park vehicle on level surface and set parking brake.
 - b. Start engine and move selector lever through each gear position. Leave selector lever in "P" position.
 - c. Check fluid level with engine idling.
 - d. Remove dipstick and note reading. If level is at low side of either range, add fluid to the charging pipe.

CAUTION:

Do not overfill.

- e. Re-insert dipstick into charging pipe as far as it will go.
- f. Remove dipstick and note reading. If reading is at low side of range, add fluid to the charging pipe.

CAUTION:

Do not overfill.

4. Drive vehicle for approximately 5 minutes in urban areas.
5. Re-check fluid level at fluid temperatures of 50° to 80°C (122° to 176°F) using "HOT" range on dipstick.
6. Check the A/T fluid condition.

- If fluid is very dark or smells burned, refer to [AT-64, "FLUID CONDITION CHECK"](#) . Flush cooling system after repair of A/T.
- If the A/T fluid contains any frictional material (clutches, bands), replace the radiator and flush the cooler lines using cleaning solvent and compressed air after repairing the A/T. Refer to [CO-13, "RADIATOR"](#) .

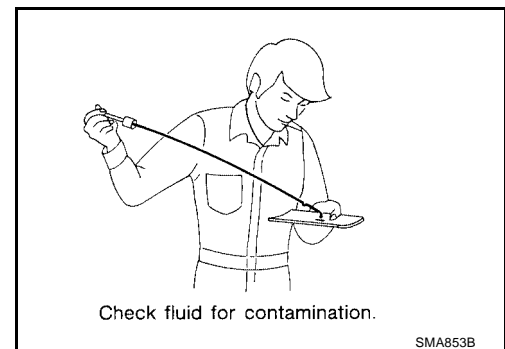
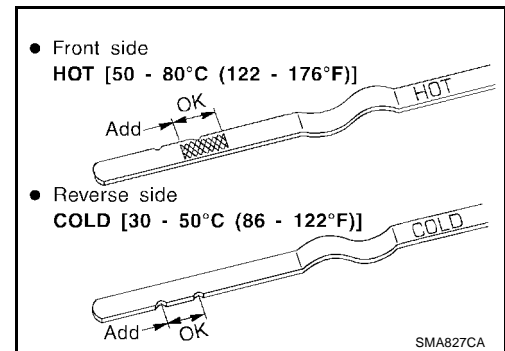

Check fluid for contamination.

CHASSIS AND BODY MAINTENANCE

Changing A/T Fluid

ELS000JB

1. Warm up A/T fluid.
2. Stop engine.
3. Drain A/T fluid from drain plug and refill with new A/T fluid. Always refill same volume with drained fluid.

Fluid grade : NISSAN Matic "D" (Continental U.S. and Alaska) or Canada NISSAN Automatic Transmission Fluid. Refer to [MA-13, "Fluids and Lubricants"](#) .

Fluid capacity (with torque converter) : RE4F03B (QG18DE) 7.0 ℓ (7 3/8 US qt, 6 1/8 Imp qt)
RE4F04B (QR25DE) 8.5 ℓ (9 US qt, 7 1/2 Imp qt)

Drain plug : 29 - 39 N·m (3.0 - 4.0 kg·m, 22 - 29 ft·lb)

4. Run engine at idle speed for five minutes.
5. Check fluid level and condition. Refer to [MA-30, "Checking A/T Fluid"](#) . If fluid is still dirty, repeat steps 2 through 5.

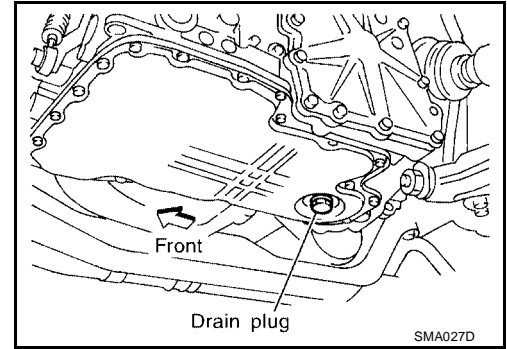

SMA027D

Balancing Wheels

ELS000JC

Adjust wheel balance using the road wheel center.

Wheel balance (maximum allowable unbalance) : Refer to [MA-31, "Balancing Wheels"](#) .

Tire Rotation

ELS000JD

- After rotating the tires, adjust the tire pressure.
- Retighten the wheel nuts when the vehicle has been driven for the first 1,000 km (600 miles) or any time the wheel and tire assembly has been removed and installed.
- Tighten wheel nuts in a criss-cross pattern to specification, making several passes.

Wheel nuts : 98 - 127 N·m (10 - 12 kg·m, 73 - 93 ft·lb)

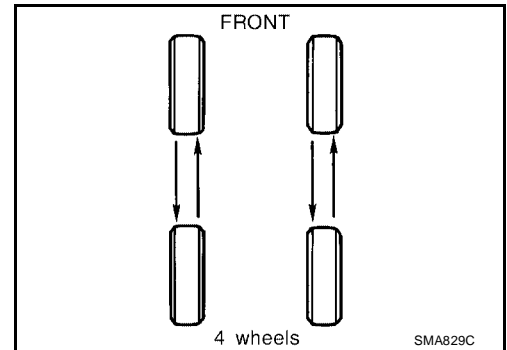

SMA829C

CHASSIS AND BODY MAINTENANCE

Checking Brake Fluid Level and Leaks

ELS000JE

- Check fluid level in reservoir tank. It should be between MAX and MIN lines on reservoir tank.
- If fluid level is extremely low, check brake system for leaks.
- Release parking brake lever and see if brake warning lamp goes off. If not, check brake system for leaks.

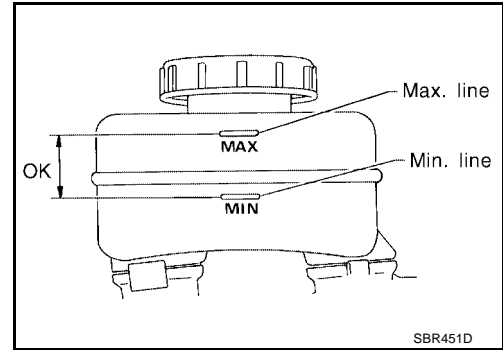

Checking Brake Lines and Cables

ELS000JF

CAUTION:

If leakage occurs around joints, retighten or, if necessary, replace damaged parts.

1. Check brake lines (tubes and hoses) for cracks, deterioration and other damage. Replace damaged parts.
2. Check for oil leakage by fully depressing brake pedal while engine is running.

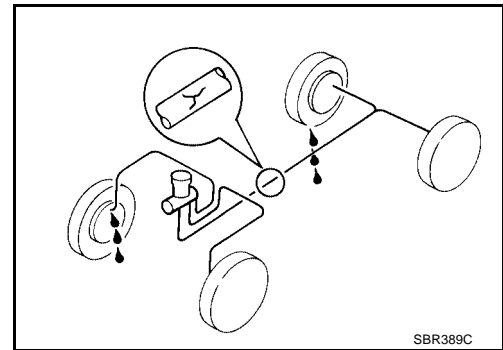

Changing Brake Fluid

ELS000JG

CAUTION:

- Refill with new brake fluid "DOT 3". Refer to [MA-13, "Fluids and Lubricants"](#).
- Always keep fluid level higher than minimum line on reservoir tank.
- Never reuse drained brake fluid.
- Be careful not to splash brake fluid on painted areas; it may cause paint damage. If brake fluid is splashed on painted areas, wash it away with water immediately.

1. Clean inside of reservoir tank, and refill with new brake fluid.
2. Connect a vinyl tube to each bleeder valve.
3. Drain brake fluid from each air bleeder valve by depressing brake pedal.
4. Refill until brake fluid comes out of each air bleeder valve. Use same procedure as in bleeding hydraulic system to refill brake fluid. Refer to [BR-7, "Bleeding Brake System"](#).

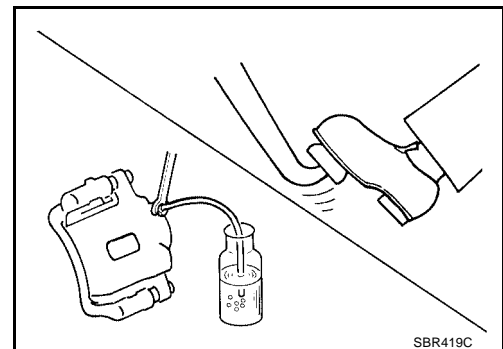

Checking Disc Brakes

ROTOR

ELS000JH

Check condition, wear, and damage. Refer to [BR-21, "ROTOR"](#) (front disc brake) and [BR-27, "ROTOR"](#) (rear disc brake).

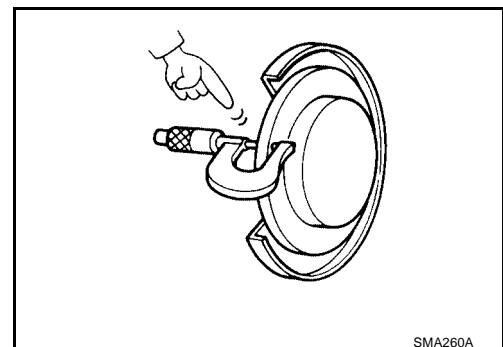

CHASSIS AND BODY MAINTENANCE

CALIPER

Check for leakage. Refer to [BR-21, "CALIPER"](#) (front disc brake) and [BR-27, "CALIPER"](#) (rear disc brake).

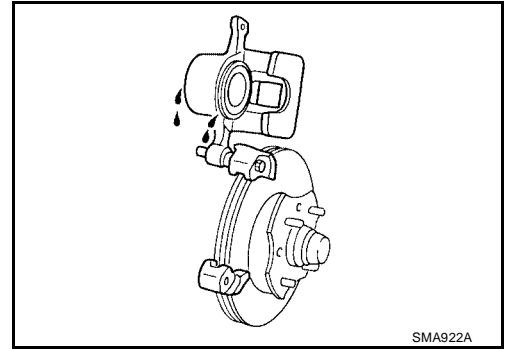

PAD

Check condition and thickness.

Standard thickness

Front : 22 mm (0.87 in)

Rear : 9 mm (0.35 in)

Minimum thickness

Front : 20 mm (0.79 in)

Rear : 8 mm (0.31 in)

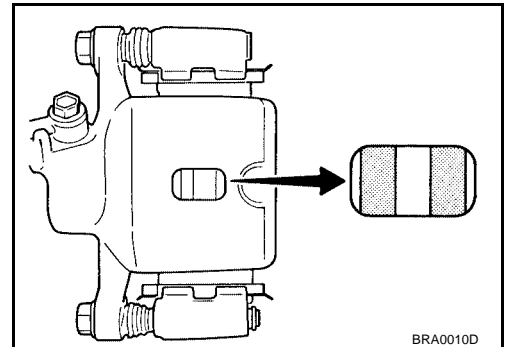

Checking Drum Brake WHEEL CYLINDER

Check operation and for leakage. Refer to [BR-33, "WHEEL CYLINDER"](#).

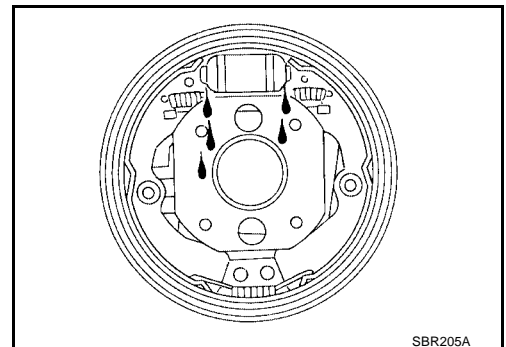

DRUM

Check condition of inner surface. Refer to [BR-33, "DRUM"](#).

Standard diameter : 203.2 mm (8.000 in)

Maximum inner diameter : 204.5 mm (8.051 in)

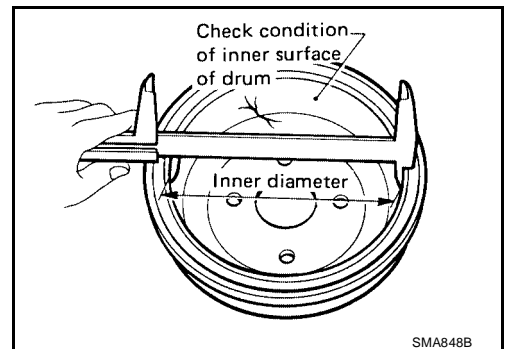

A
B
C
D
E
F
G
H
I
J
K
MA
M

CHASSIS AND BODY MAINTENANCE

LINING

Measure wear and check for damage. Refer to [BR-33, "LINING"](#) .

Standard thickness : 4.5 mm (0.177 in)

Minimum thickness : 1.5 mm (0.059 in)

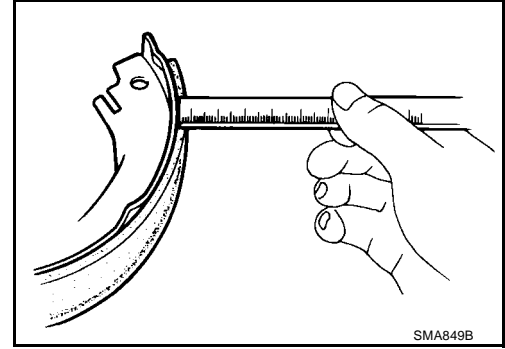

Checking Steering Gear and Linkage

STEERING GEAR

- Check gear housing and boots for looseness, damage and grease leakage.
- Check connection with steering column for looseness.

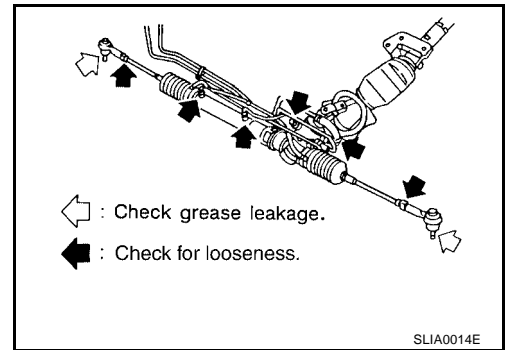

STEERING LINKAGE

- Check ball joint, dust cover and other component parts for looseness, wear, damage and grease leakage.

Checking Power Steering Fluid and Lines

CHECKING FLUID LEVEL

- Check fluid level with engine off.
- Use the correct range of the tank depending on the fluid temperature. Use "HOT" range at fluid temperatures of 50° to 80°C (122° to 176°F). Use "COLD" range at fluid temperatures of 0° to 30°C (32° to 86°F).

CAUTION:

Do not overfill.

- Recommended fluid is Genuine NISSAN PSF or equivalent. Refer to [MA-13, "RECOMMENDED FLUIDS AND LUBRICANTS"](#) .

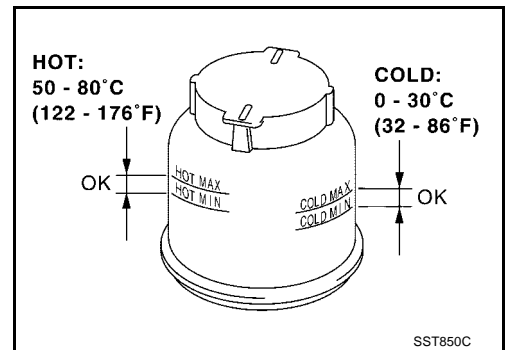

CHECKING LINES

- Check lines for improper attachment, leaks, cracks, damage, loose connections, chafing and deterioration.
- Check rack boots for accumulation of power steering fluid.

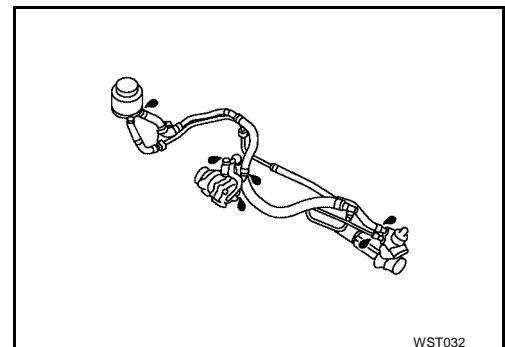

CHASSIS AND BODY MAINTENANCE

Axle and Suspension Parts

ELS000JL

Check front and rear axle and suspension parts for excessive play, cracks, wear, or other damage.

- Shake each wheel to check for excessive play.
- Rotate each wheel to check for abnormal noise.

- Check axle and suspension nuts and bolts for looseness.

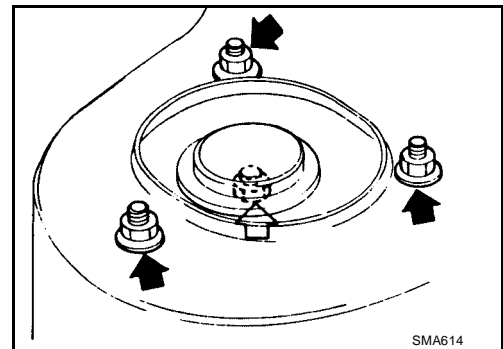
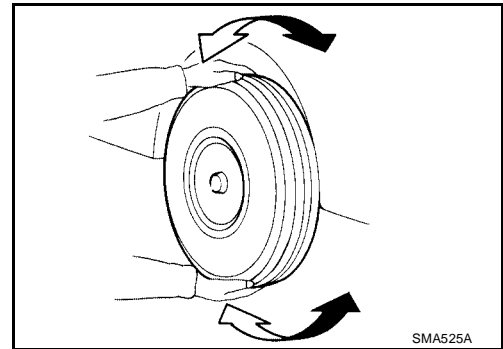

- Check strut (shock absorber) for oil leakage or other damage.

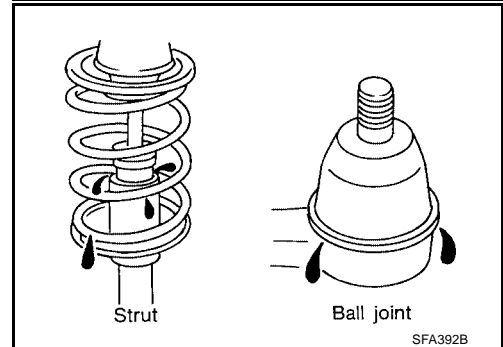
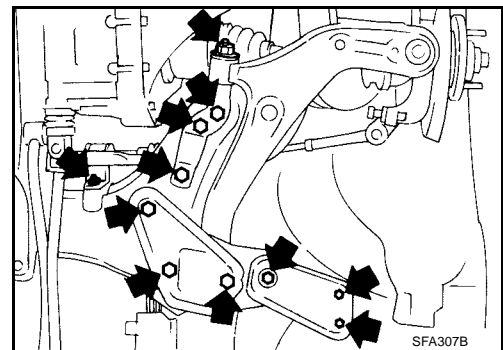

- Check suspension ball joint for grease leakage and ball joint dust cover for cracks or other damage.

A
B
C
D
E
F
G
H
I
J
K
MA
M

CHASSIS AND BODY MAINTENANCE

Drive Shaft

ELS000JM

- Check boot and drive shaft for cracks, wear, damage and grease leakage.

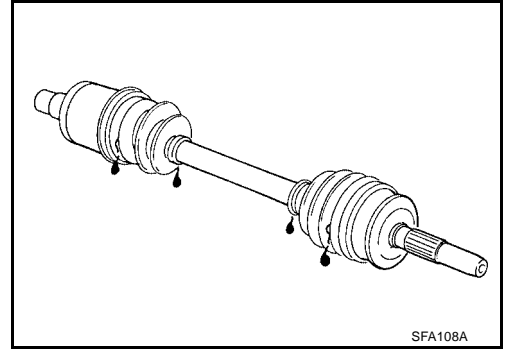

Lubricating Locks, Hinges and Hood Latches

ELS000JN

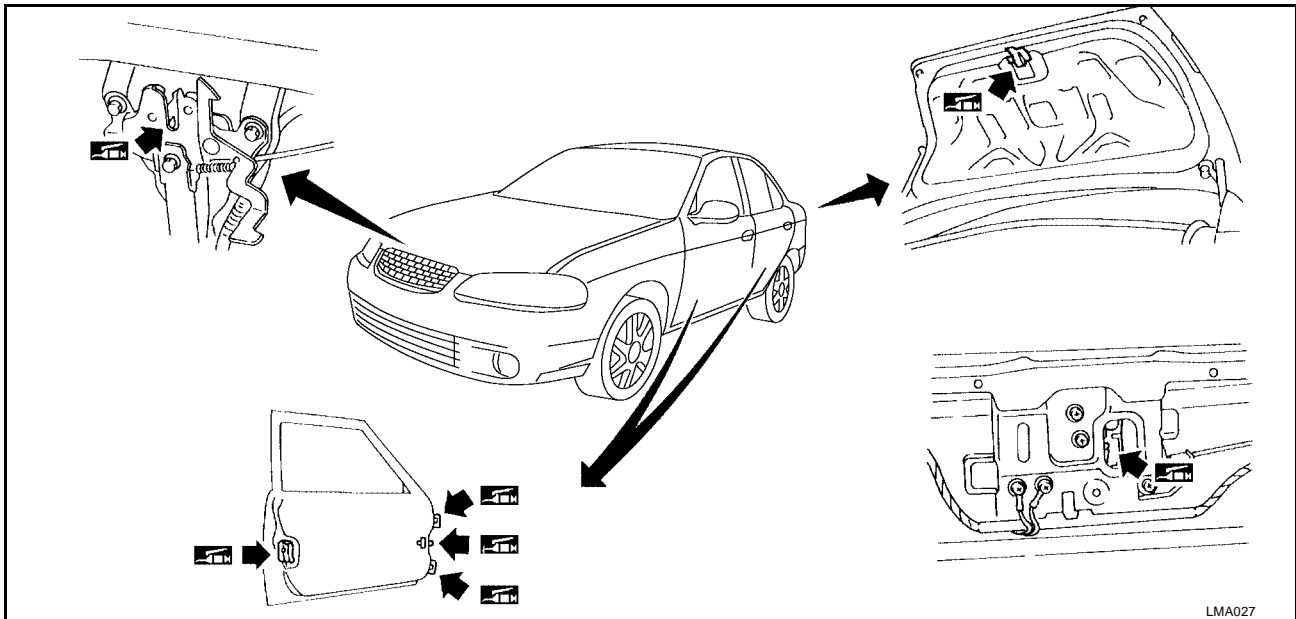

Checking Seat Belt, Buckles, Retractors, Anchors and Adjusters

ELS000JO

CAUTION:

- After any collision, inspect all seat belt assemblies, including retractors and other attached hardware (i.e. anchor bolt, guide rail set). Nissan recommends to replace all seat belt assemblies in use during a collision, unless not damaged and properly operating after minor collision. Also inspect seat belt assemblies not in use during a collision, and replace if damaged or improperly operating. Seat belt pre-tensioner should be replaced even if the seat belts are not in use during a frontal collision where the driver and passenger air bags are deployed.
- If any component of seat belt assembly is questionable, do not repair. Replace as seat belt assembly.
- If webbing is cut, frayed, or damaged, replace belt assembly.
- Never oil tongue and buckle.
- Use a Genuine NISSAN seat belt assembly.

For details, refer to "Seat Belt Inspection" in SB section.

Anchor bolt

 43.1 – 54.9 (4.4 – 5.6, 32 – 40)

 : N·m (kg·m, ft·lb)

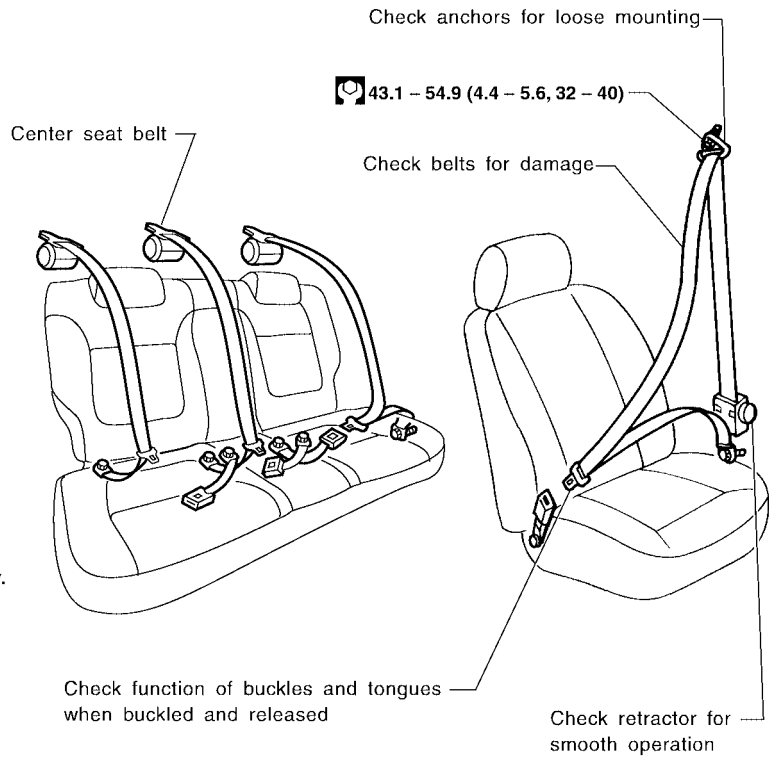

LLIA0020E

A
B
C
D
E
F
G
H
I
J
K
L
M

MA

SERVICE DATA AND SPECIFICATIONS (SDS)

SERVICE DATA AND SPECIFICATIONS (SDS)

PFP:00030

Engine Maintenance (QG18DE) BELT DEFLECTION AND TENSION

ELS000JP

Component		Deflection adjustment Unit: mm (in)			Tension adjustment *1 Unit: N (kg, lb)		
		Used Belt		New Belt	Used Belt		New Belt
		Limit	After Adjustment		Limit	After Adjustment	
Generator	With air conditioner compressor	8.1 (0.319)	5.3 - 5.7 (0.209 - 0.244)	4.5 - 5.0 (0.177 - 0.197)	292 (30, 66)	652 - 740 (66.5 - 75.5, 146.6 - 166.4)	789 - 877 (80.5 - 89.5, 177.4 - 197.1)
	Without air conditioner compressor	10.2 (0.402)	6.5 - 7.0 (0.256 - 0.276)	5.5 - 6.1 (0.217 - 0.240)	292 (30, 60)	652 - 740 (66.5 - 75.5, 146.6 - 166.4)	789 - 877 (80.5 - 89.5, 177.4 - 197.1)
Power steering oil pump		7.1 (0.280)	4.4 - 4.9 (0.173 - 0.193)	3.9 - 4.4 (0.154 - 0.173)	196 (20, 44)	495 - 583 (50.5 - 59.5, 111.4 - 131.2)	603 - 691 (61.5 - 70.5, 135.6 - 155.5)
Applied pushing force		98 N (10 kg, 22 lb)			—		

*1: If the belt tension gauge cannot be installed at check points shown, check belt tension at a different location on the belt.

SPARK PLUGS (DOUBLE PLATINUM - TIPPED)

Type	Standard	PLFR5A-11
	Hot	PLFR4A-11
	Cold	PLFR6A-11
Plug gap		Nominal: 1.1 mm (0.043 in)

Engine Maintenance (QR25DE) BELT DEFLECTION AND TENSION

ELS000JQ

Tension of drive belts

Auto-adjustment by auto tensioner

SPARK PLUGS (DOUBLE PLATINUM - TIPPED)

Type	Standard	PLFR5A-11
	Hot	PLFR4A-11
	Cold	PLFR6A-11
Plug gap		Nominal: 1.1 mm (0.043 in)

Chassis and Body Maintenance WHEEL BALANCE

ELS000JR

Maximum allowable unbalance	Dynamic (At rim flange) g (oz)	10 (0.35) (one side)
	Static g (oz)	20 (0.71)