

SECTION **CVT**
CVT

CONTENTS

SERVICE INFORMATION	5	ON BOARD DIAGNOSTIC (OBD) SYSTEM	26
INDEX FOR DTC	5	Introduction	26
Alphabetical Index	5	OBD-II Function for CVT System	26
DTC No. Index	5	One or Two Trip Detection Logic of OBD-II	26
PRECAUTIONS	7	OBD-II Diagnostic Trouble Code (DTC)	26
Precaution for Supplemental Restraint System (SRS) "AIR BAG" and "SEAT BELT PRE-TENSIONER"	7	Malfunction Indicator Lamp (MIL)	27
Precaution Necessary for Steering Wheel Rotation After Battery Disconnect	7	TROUBLE DIAGNOSIS	29
Precaution for On Board Diagnosis (OBD) System of CVT and Engine	7	DTC Inspection Priority Chart	29
Service After Replacing TCM and Transaxle Assembly	8	Fail-Safe	29
Removal and Installation Procedure for CVT Unit Connector	9	How to Perform Trouble Diagnosis for Quick and Accurate Repair	30
Precaution	10	CVT Electrical Parts Location	35
Service Notice or Precaution	11	Circuit Diagram	36
PREPARATION	12	Inspections before Trouble Diagnosis	36
Special Service Tool	12	Road Test	40
Commercial Service Tool	12	Check before Engine Is Started	41
CVT FLUID	13	Check at Idle	41
Checking CVT Fluid	13	Cruise Test	43
Changing CVT Fluid	14	Vehicle Speed When Shifting Gears	45
CVT Fluid Cooler Cleaning	14	TCM Terminal and Reference Value	45
CVT SYSTEM	18	CONSULT-III Function (TRANSMISSION)	47
Cross-Sectional View - RE0F08A	18	Diagnosis Procedure without CONSULT-III	55
Control System	19	DTC U1000 CAN COMMUNICATION LINE	56
Hydraulic Control System	20	Description	56
TCM Function	20	On Board Diagnosis Logic	56
CAN Communication	21	Possible Cause	56
Input/Output Signal of TCM	22	DTC Confirmation Procedure	56
Line Pressure and Secondary Pressure Control	22	Wiring Diagram - CVT - CAN	57
Shift Control	23	Diagnosis Procedure	58
Lock-up and Select Control	24	DTC U1010 TRANSMISSION CONTROL MODULE (CAN)	59
Control Valve	25	Description	59
		On Board Diagnosis Logic	59
		Possible Cause	59
		DTC Confirmation Procedure	59
		Diagnosis Procedure	59
		DTC P0615 START SIGNAL CIRCUIT	60

Description	60	DTC Confirmation Procedure	80
CONSULT-III Reference Value in Data Monitor		Wiring Diagram - CVT - SESCVT	81
Mode	60	Diagnosis Procedure	82
On Board Diagnosis Logic	60	DTC P0725 ENGINE SPEED SIGNAL	85
Possible Cause	60	Description	85
DTC Confirmation Procedure	60	CONSULT-III Reference Value in Data Monitor	
Wiring Diagram - CVT - STSIG	61	Mode	85
Diagnosis Procedure	62	On Board Diagnosis Logic	85
DTC P0703 STOP LAMP SWITCH CIRCUIT ...	63	Possible Cause	85
Description	63	DTC Confirmation Procedure	85
CONSULT-III Reference Value in Data Monitor		Diagnosis Procedure	85
Mode	63	DTC P0730 BELT DAMAGE	87
On Board Diagnosis Logic	63	Description	87
Possible Cause	63	CONSULT-III Reference Value in Data Monitor	
DTC Confirmation Procedure	63	Mode	87
Diagnosis Procedure	63	On Board Diagnosis Logic	87
DTC P0705 PARK/NEUTRAL POSITION		Possible Cause	87
SWITCH	65	DTC Confirmation Procedure	87
Description	65	Diagnosis Procedure	87
CONSULT-III Reference Value in Data Monitor		DTC P0740 TORQUE CONVERTER CLUTCH	
Mode	65	SOLENOID VALVE	88
On Board Diagnosis Logic	65	Description	88
Possible Cause	65	CONSULT-III Reference Value in Data Monitor	
DTC Confirmation Procedure	65	Mode	88
Wiring Diagram - CVT - PNP/SW	67	On Board Diagnosis Logic	88
Diagnosis Procedure	68	Possible Cause	88
Component Inspection	70	DTC Confirmation Procedure	88
DTC P0710 CVT FLUID TEMPERATURE		Wiring Diagram - CVT - TCV	89
SENSOR CIRCUIT	71	Diagnosis Procedure	90
Description	71	Component Inspection	91
CONSULT-III Reference Value in Data Monitor		DTC P0744 A/T TCC S/V FUNCTION (LOCK-	
Mode	71	UP)	93
On Board Diagnosis Logic	71	Description	93
Possible Cause	71	CONSULT-III Reference Value in Data Monitor	
DTC Confirmation Procedure	71	Mode	93
Wiring Diagram - CVT - FTS	72	On Board Diagnosis Logic	93
Diagnosis Procedure	73	Possible Cause	93
Component Inspection	74	DTC Confirmation Procedure	93
DTC P0715 INPUT SPEED SENSOR CIR-		Diagnosis Procedure	93
CUIT (PRI SPEED SENSOR)	76	DTC P0745 LINE PRESSURE SOLENOID	
Description	76	VALVE	95
CONSULT-III Reference Value in Data Monitor		Description	95
Mode	76	CONSULT-III Reference Value in Data Monitor	
On Board Diagnosis Logic	76	Mode	95
Possible Cause	76	On Board Diagnosis Logic	95
DTC Confirmation Procedure	76	Possible Cause	95
Wiring Diagram - CVT - PRSCVT	77	DTC Confirmation Procedure	95
Diagnosis Procedure	78	Wiring Diagram - CVT - LPSV	96
DTC P0720 VEHICLE SPEED SENSOR CVT		Diagnosis Procedure	97
(SECONDARY SPEED SENSOR)	80	Component Inspection	98
Description	80	DTC P0746 PRESSURE CONTROL SOLE-	
CONSULT-III Reference Value in Data Monitor		NOID A PERFORMANCE (LINE PRESSURE	
Mode	80	SOLENOID VALVE)	100
On Board Diagnosis Logic	80	Description	100
Possible Cause	80		

CONSULT-III Reference Value in Data Monitor Mode	100	On Board Diagnosis Logic	115	
On Board Diagnosis Logic	100	Possible Cause	115	A
Possible Cause	100	DTC Confirmation Procedure	115	
DTC Confirmation Procedure	100	Wiring Diagram - CVT - PRIPS	116	
Diagnosis Procedure	100	Diagnosis Procedure	117	B
DTC P0776 PRESSURE CONTROL SOLENOID B PERFORMANCE (SEC PRESSURE SOLENOID VALVE)	102	DTC P0868 SECONDARY PRESSURE DOWN	119	CVT
Description	102	Description	119	
CONSULT-III Reference Value in Data Monitor Mode	102	CONSULT-III Reference Value in Data Monitor Mode	119	
On Board Diagnosis Logic	102	On Board Diagnosis Logic	119	D
Possible Cause	102	Possible Cause	119	
DTC Confirmation Procedure	102	DTC Confirmation Procedure	119	E
Diagnosis Procedure	102	Diagnosis Procedure	119	
DTC P0778 PRESSURE CONTROL SOLENOID B ELECTRICAL (SEC PRESSURE SOLENOID VALVE)	104	DTC P1701 TRANSMISSION CONTROL MODULE (POWER SUPPLY)	121	F
Description	104	Description	121	
CONSULT-III Reference Value in Data Monitor Mode	104	On Board Diagnosis Logic	121	
On Board Diagnosis Logic	104	Possible Cause	121	G
Possible Cause	104	DTC Confirmation Procedure	121	
DTC Confirmation Procedure	104	Wiring Diagram - CVT - POWER	122	
Wiring Diagram - CVT - SECPSV	105	Diagnosis Procedure	123	H
Diagnosis Procedure	106	DTC P1705 THROTTLE POSITION SENSOR. 125		
Component Inspection	107	Description	125	I
DTC P0840 TRANSMISSION FLUID PRESSURE SENSOR A CIRCUIT (SEC PRESSURE SENSOR)	109	CONSULT-III Reference Value in Data Monitor Mode	125	J
Description	109	On Board Diagnosis Logic	125	
CONSULT-III Reference Value in Data Monitor Mode	109	Possible Cause	125	
On Board Diagnosis Logic	109	DTC Confirmation Procedure	125	K
Possible Cause	109	Diagnosis Procedure	125	
DTC Confirmation Procedure	109	DTC P1722 ESTM VEHICLE SPEED SIGNAL. 127		
Wiring Diagram - CVT - SECPS	110	Description	127	L
Diagnosis Procedure	111	CONSULT-III Reference Value in Data Monitor Mode	127	
DTC P0841 PRESSURE SENSOR FUNCTION	113	On Board Diagnosis Logic	127	M
Description	113	Possible Cause	127	
CONSULT-III Reference Value in Data Monitor Mode	113	DTC Confirmation Procedure	127	
On Board Diagnosis Logic	113	Diagnosis Procedure	127	N
Possible Cause	113	DTC P1723 CVT SPEED SENSOR FUNCTION	129	
DTC Confirmation Procedure	113	Description	129	O
Diagnosis Procedure	113	On Board Diagnosis Logic	129	
DTC P0845 TRANSMISSION FLUID PRESSURE SENSOR B CIRCUIT (PRI PRESSURE SENSOR)	115	Possible Cause	129	
Description	115	DTC Confirmation Procedure	129	
CONSULT-III Reference Value in Data Monitor Mode	115	Diagnosis Procedure	129	P
DTC P1726 ELECTRIC THROTTLE CONTROL SYSTEM	131	Description	131	
Description	131	On Board Diagnosis Logic	131	
On Board Diagnosis Logic	131	Possible Cause	131	
Possible Cause	131	DTC Confirmation Procedure	131	
DTC Confirmation Procedure	131	Diagnosis Procedure	131	
Diagnosis Procedure	131			

DTC P1740 LOCK-UP SELECT SOLENOID VALVE CIRCUIT	132	O/D OFF Indicator Lamp Does Not Come On	151
Description	132	Engine Cannot Be Started in "P" and "N" Position.	153
CONSULT-III Reference Value in Data Monitor		In "P" Position, Vehicle Moves Forward or Back-	
Mode	132	ward When Pushed	153
On Board Diagnosis Logic	132	In "N" Position, Vehicle Moves	154
Possible Cause	132	Large Shock "N" → "R" Position	154
DTC Confirmation Procedure	132	Vehicle Does Not Creep Backward in "R" Position.	155
Wiring Diagram - CVT - L/USSV	133	Vehicle Does Not Creep Forward in "D" or "L" Po-	
Diagnosis Procedure	134	sition	156
Component Inspection	135	Vehicle Speed Does Not Change in "L" Position .	157
		Vehicle Speed Does Not Change in overdrive-off	
		mode	158
		Vehicle Speed Does Not Change in "D" Position .	159
		Vehicle Does Not Decelerate by Engine Brake ...	159
DTC P1745 LINE PRESSURE CONTROL	136	TRANSMISSION CONTROL MODULE	161
Description	136	Removal and Installation	161
On Board Diagnosis Logic	136	CVT SHIFT LOCK SYSTEM	162
Possible Cause	136	Description	162
DTC Confirmation Procedure	136	Shift Lock System Electrical Parts Location	162
Diagnosis Procedure	136	Wiring Diagram - CVT - SHIFT	163
		Diagnosis Procedure	163
DTC P1777 STEP MOTOR - CIRCUIT	137	SHIFT CONTROL SYSTEM	167
Description	137	Removal and Installation	167
CONSULT-III Reference Value in Data Monitor		Control Device Disassembly and Assembly	170
Mode	137	Selector Lever Knob Removal and Installation	170
On Board Diagnosis Logic	137	Adjustment of CVT Position	171
Possible Cause	137	Checking of CVT Position	171
DTC Confirmation Procedure	137	KEY INTERLOCK CABLE	173
Wiring Diagram - CVT - STM	138	Removal and Installation	173
Diagnosis Procedure	139	AIR BREATHER HOSE	176
Component Inspection	140	Removal and Installation	176
DTC P1778 STEP MOTOR - FUNCTION	141	DIFFERENTIAL SIDE OIL SEAL	177
Description	141	Removal and Installation	177
CONSULT-III Reference Value in Data Monitor		TRANSAXLE ASSEMBLY	178
Mode	141	Removal and Installation	178
On Board Diagnosis Logic	141	SERVICE DATA AND SPECIFICATIONS	
Possible Cause	141	(SDS)	181
DTC Confirmation Procedure	141	General Specification	181
Diagnosis Procedure	142	Vehicle Speed When Shifting Gears	181
		Stall Speed	181
OVERDRIVE CONTROL SWITCH	143	Line Pressure	181
Description	143	Solenoid Valves	182
CONSULT-III Reference Value in Data Monitor		CVT Fluid Temperature Sensor	182
Mode	143	Primary Speed Sensor	182
Wiring Diagram - CVT - ODSW	144	Secondary Speed Sensor	182
Diagnosis Procedure	144	Removal and Installation	182
Component Inspection	146		
SHIFT POSITION INDICATOR CIRCUIT	148		
Description	148		
CONSULT-III Reference Value in Data Monitor			
Mode	148		
Diagnosis Procedure	148		
TROUBLE DIAGNOSIS FOR SYMPTOMS	149		
Wiring Diagram - CVT - NONDTC	149		

INDEX FOR DTC

< SERVICE INFORMATION >

SERVICE INFORMATION

INDEX FOR DTC

Alphabetical Index

INFOID:000000001703422

NOTE:

If DTC “U1000 CAN COMM CIRCUIT” is displayed with other DTCs, first perform the trouble diagnosis for “DTC U1000 CAN COMMUNICATION LINE”. Refer to [CVT-56](#).

Items (CONSULT-III screen terms)	DTC		Reference page
	OBD-II	Except OBD-II	
	CONSULT-III GST*1	CONSULT-III only “TRANSMISSION”	
A/T TCC S/V FNCTN	P0744	P0744	CVT-93
ATF TEMP SEN/CIRC	P0710	P0710	CVT-71
BELT DAMG	—	P0730	CVT-87
BRAKE SW/CIRC	—	P0703	CVT-63
CAN COMM CIRCUIT	U1000	U1000	CVT-56
CONTROL UNIT(CAN)	U1010	U1010	CVT-59
CVT SPD SEN/FNCTN	—	P1723	CVT-129
ENGINE SPEED SIG	—	P0725	CVT-85
ELEC TH CONTROL	—	P1726	CVT-131
ESTM VEH SPD SIG*2	—	P1722	CVT-127
INPUT SPD SEN/CIRC	P0715	P0715	CVT-76
L/PRESS CONTROL	—	P1745	CVT-136
L/PRESS SOL/CIRC	P0745	P0745	CVT-95
LU-SLCT SOL/CIRC	P1740	P1740	CVT-132
PNP SW/CIRC	P0705	P0705	CVT-65
PRESS SEN/FNCTN	—	P0841	CVT-113
PRS CNT SOL/A FCTN	P0746	P0746	CVT-100
PRS CNT SOL/B CIRC	P0778	P0778	CVT-104
PRS CNT SOL/B FCTN	P0776	P0776	CVT-102
SEC/PRESS DOWN	—	P0868	CVT-119
STARTER RELAY/CIRC	—	P0615	CVT-60
STEP MOTR CIRC	P1777	P1777	CVT-137
STEP MOTR/FNC	P1778	P1778	CVT-141
TCC SOLENOID/CIRC	P0740	P0740	CVT-88
TCM-POWER SUPPLY	—	P1701	CVT-121
TP SEN/CIRC A/T	—	P1705	CVT-125
TR PRS SENS/A CIRC	P0840	P0840	CVT-109
TR PRS SENS/B CIRC	P0845	P0845	CVT-115
VEH SPD SEN/CIR AT	P0720	P0720	CVT-80

*1: These numbers are prescribed by SAE J2012.

*2: Models without ABS does not indicate.

DTC No. Index

INFOID:000000001703423

NOTE:

INDEX FOR DTC

< SERVICE INFORMATION >

If DTC “U1000 CAN COMM CIRCUIT” is displayed with other DTCs, first perform the trouble diagnosis for “DTC U1000 CAN COMMUNICATION LINE”. Refer to [CVT-56](#).

DTC		Items (CONSULT-III screen terms)	Reference page
OBD-II	Except OBD-II		
CONSULT-III GST*1	CONSULT-III only “TRANSMISSION”		
—	P0615	STARTER RELAY/CIRC	CVT-60
—	P0703	BRAKE SW/CIRC	CVT-63
P0705	P0705	PNP SW/CIRC	CVT-65
P0710	P0710	ATF TEMP SEN/CIRC	CVT-71
P0715	P0715	INPUT SPD SEN/CIRC	CVT-76
P0720	P0720	VEH SPD SEN/CIR AT	CVT-80
—	P0725	ENGINE SPEED SIG	CVT-85
—	P0730	BELT DAMG	CVT-87
P0740	P0740	TCC SOLENOID/CIRC	CVT-88
P0744	P0744	A/T TCC S/V FNCTN	CVT-93
P0745	P0745	L/PRESS SOL/CIRC	CVT-95
P0746	P0746	PRS CNT SOL/A FCTN	CVT-100
P0776	P0776	PRS CNT SOL/B FCTN	CVT-102
P0778	P0778	PRS CNT SOL/B CIRC	CVT-104
P0840	P0840	TR PRS SENS/A CIRC	CVT-109
—	P0841	PRESS SEN/FNCTN	CVT-113
P0845	P0845	TR PRS SENS/B CIRC	CVT-115
—	P0868	SEC/PRESS DOWN	CVT-119
—	P1701	TCM-POWER SUPPLY	CVT-121
—	P1705	TP SEN/CIRC A/T	CVT-125
—	P1722	ESTM VEH SPD SIG*2	CVT-127
—	P1723	CVT SPD SEN/FNCTN	CVT-129
—	P1726	ELEC TH CONTROL	CVT-131
P1740	P1740	LU-SLCT SOL/CIRC	CVT-132
—	P1745	L/PRESS CONTROL	CVT-136
P1777	P1777	STEP MOTR CIRC	CVT-137
P1778	P1778	STEP MOTR/FNC	CVT-141
U1000	U1000	CAN COMM CIRCUIT	CVT-56
U1010	U1010	CONTROL UNIT(CAN)	CVT-59

*1: These numbers are prescribed by SAE J2012.

*2: Models without ABS does not indicate.

PRECAUTIONS

< SERVICE INFORMATION >

PRECAUTIONS

Precaution for Supplemental Restraint System (SRS) "AIR BAG" and "SEAT BELT PRE-TENSIONER"

INFOID:000000001703424

The Supplemental Restraint System such as "AIR BAG" and "SEAT BELT PRE-TENSIONER", used along with a front seat belt, helps to reduce the risk or severity of injury to the driver and front passenger for certain types of collision. This system includes seat belt switch inputs and dual stage front air bag modules. The SRS system uses the seat belt switches to determine the front air bag deployment, and may only deploy one front air bag, depending on the severity of a collision and whether the front occupants are belted or unbelted. Information necessary to service the system safely is included in the SRS and SB section of this Service Manual.

WARNING:

- To avoid rendering the SRS inoperative, which could increase the risk of personal injury or death in the event of a collision which would result in air bag inflation, all maintenance must be performed by an authorized NISSAN/INFINITI dealer.
- Improper maintenance, including incorrect removal and installation of the SRS, can lead to personal injury caused by unintentional activation of the system. For removal of Spiral Cable and Air Bag Module, see the SRS section.
- Do not use electrical test equipment on any circuit related to the SRS unless instructed to in this Service Manual. SRS wiring harnesses can be identified by yellow and/or orange harnesses or harness connectors.

Precaution Necessary for Steering Wheel Rotation After Battery Disconnect

INFOID:000000001703425

NOTE:

- This Procedure is applied only to models with Intelligent Key system and NVIS/IVIS (NISSAN/INFINITI VEHICLE IMMOBILIZER SYSTEM - NATS).
- Remove and install all control units after disconnecting both battery cables with the ignition knob in the "LOCK" position.
- Always use CONSULT-III to perform self-diagnosis as a part of each function inspection after finishing work. If DTC is detected, perform trouble diagnosis according to self-diagnostic results.

For models equipped with the Intelligent Key system and NVIS/IVIS, an electrically controlled steering lock mechanism is adopted on the key cylinder.

For this reason, if the battery is disconnected or if the battery is discharged, the steering wheel will lock and steering wheel rotation will become impossible.

If steering wheel rotation is required when battery power is interrupted, follow the procedure below before starting the repair operation.

OPERATION PROCEDURE

1. Connect both battery cables.

NOTE:

Supply power using jumper cables if battery is discharged.

2. Use the Intelligent Key or mechanical key to turn the ignition switch to the "ACC" position. At this time, the steering lock will be released.
3. Disconnect both battery cables. The steering lock will remain released and the steering wheel can be rotated.
4. Perform the necessary repair operation.
5. When the repair work is completed, return the ignition switch to the "LOCK" position before connecting the battery cables. (At this time, the steering lock mechanism will engage.)
6. Perform a self-diagnosis check of all control units using CONSULT-III.

Precaution for On Board Diagnosis (OBD) System of CVT and Engine

INFOID:000000001703426

The ECM has an on board diagnostic system. It will light up the malfunction indicator lamp (MIL) to warn the driver of a malfunction causing emission deterioration.

CAUTION:

PRECAUTIONS

< SERVICE INFORMATION >

- Be sure to turn the ignition switch OFF and disconnect the battery cable from the negative terminal before any repair or inspection work. The open/short circuit of related switches, sensors, solenoid valves, etc. will cause the MIL to light up.
- Be sure to connect and lock the connectors securely after work. A loose (unlocked) connector will cause the MIL to light up due to an open circuit. (Be sure the connector is free from water, grease, dirt, bent terminals, etc.)
- Be sure to route and secure the harnesses properly after work. Interference of the harness with a bracket, etc. may cause the MIL to light up due to a short circuit.
- Be sure to connect rubber tubes properly after work. A misconnected or disconnected rubber tube may cause the MIL to light up due to a malfunction of the EVAP system or fuel injection system, etc.
- Be sure to erase the unnecessary malfunction information (repairs completed) from the TCM and ECM before returning the vehicle to the customer.

Service After Replacing TCM and Transaxle Assembly

INFOID:000000001703427

SERVICE AFTER REPLACING TCM AND TRANSAXLE ASSEMBLY

Perform the applicable service in the following sheet when replacing TCM or transaxle assembly

CAUTION:

- Do not start the engine until the service is completed.
- "A/T C/U POWER SUPPLY [P1701]" may be indicated soon after replacing TCM or transaxle assembly (after erasing the memory at the pattern B). Restart the self-diagnosis after erasing the self-diagnosis result. Check that no error is detected.

TCM	CVT assembly	Service pattern
Replace the new unit.	Do not replace the unit.	"PATTERN A"
Do not replace the unit.	Replace the new or old unit.	"PATTERN B"
Replace the old unit.	Do not replace the unit.	
	Replace the new or old unit.	
Replace the new unit.	Replace the new or old unit.	"PATTERN C"

NOTE:

Old unit means that the unit has been already used for another vehicle.

PATTERN A

1. Shift the selector lever to "P" position after replacing TCM. Turn the ignition switch ON.
2. Check that the shift position indicator in the combination meter turns ON (It indicates approximately 1 or 2 seconds after turning the ignition switch ON.)
 - Check the following items if the shift position indicator does not turn ON. Repair or replace the shift position indicator if necessary.
 - The harness between TCM and ROM ASSY in the transaxle assembly is open or short.
 - Cable disconnected, loosen, or bent from the connector housing.

PATTERN B

1. Turn the ignition switch ON after replacing each part.
2. Start engine.
CAUTION:
Do not start the driving.
3. Touch CONSULT-III screen in the order of "START (NISSAN BASED VHCL)", "TRANSMISSION", "DATA MONITOR", and "MAIN SIGNALS".
4. Warm up the transaxle assembly until "ATFTEMPCOUNT" indicates 47 [approximately 20°C (68°F)] or more. Turn the ignition switch OFF.
5. Turn the ignition switch ON.
CAUTION:
Do not start engine.
6. Select "SELF-DIAG RESULTS".
7. Shift the selector lever to "R" position.
8. Depress slightly the accelerator pedal (Pedal angle: 2/8) while depressing the brake pedal.
9. Perform "ERASE".

PRECAUTIONS

< SERVICE INFORMATION >

10. Shift the selector lever to "R" position after replacing TCM. Turn the ignition switch OFF.
11. Wait approximately 10 minutes after turning the ignition switch OFF.
12. Turn the ignition switch ON while shifting the selector lever to "R" position.
CAUTION:
Do not start engine.
13. Select "CALIBRATION DATA".
14. Check that the value on "CALIBRATION DATA" is same as the data after erasing "Calibration Data".
 - Restart the procedure from step 3 if the values are not same.
15. Shift the selector lever to "P" position.
16. Check that the shift position indicator in the combination meter turns ON (It indicates approximately 1 or 2 seconds after shifting the selector lever to "P" position.)
 - Check the following items if the shift position indicator does not turn ON. Repair or replace the shift position indicator if necessary.
 - The harness between TCM and ROM ASSY in the transaxle assembly is open or short.
 - Cable disconnected, loosen, or bent from the connector housing.
 - Power supply and ground of TCM. Refer to [CVT-121](#).

PATTERN C

1. Replace the transaxle assembly first, and then replace TCM.
2. Perform the service of "PATTERN A".
(Perform the service of "Pattern B" if TCM is replaced first.)

Removal and Installation Procedure for CVT Unit Connector

INFOID:000000001703428

REMOVAL

Rotate bayonet ring counterclockwise, pull out CVT unit harness connector upward and disconnect it.

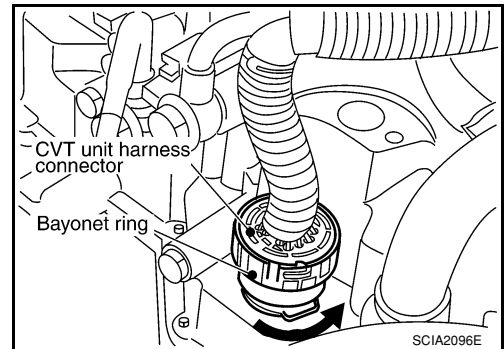

INSTALLATION

1. Align CVT unit harness connector terminal body marking with bayonet ring marking, insert CVT unit harness connector, and then rotate bayonet ring clockwise.

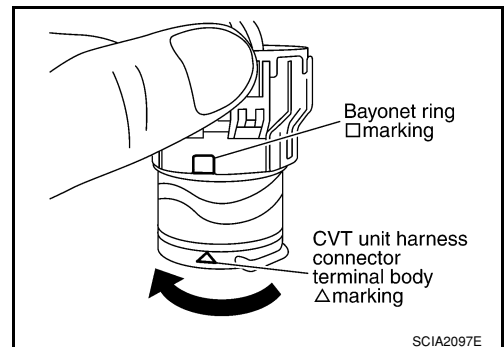

A
B
CVT
D
E
F
G
H
I
J
K
L
M
N
O
P

PRECAUTIONS

< SERVICE INFORMATION >

2. Rotate bayonet ring clockwise until CVT unit harness connector terminal body marking is aligned with the bayonet ring marking (linear slit) as shown.

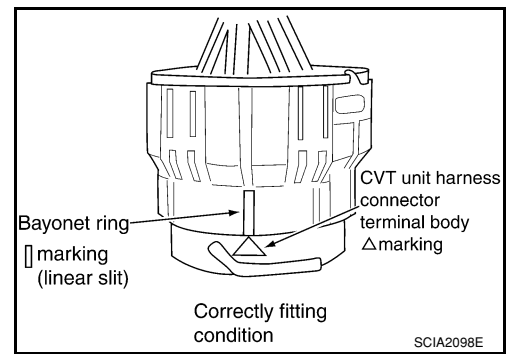

CAUTION:

- Securely align CVT unit harness connector terminal body marking with bayonet ring marking (linear slit). Do not make a half fit condition as shown.
- Do not mistake the bayonet ring marking (linear slit) for other dent portion.

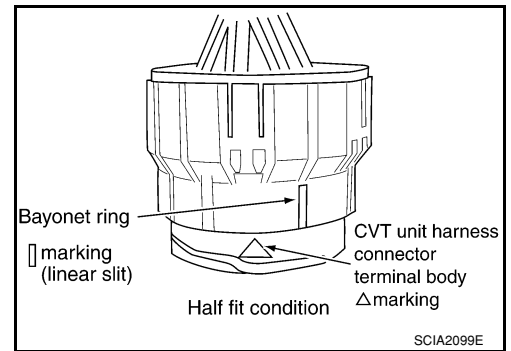

Precaution

INFOID:000000001703429

NOTE:

If any malfunction occurs in the RE0F08A model transaxle, replace the entire transaxle assembly.

- Before connecting or disconnecting the TCM harness connector, turn ignition switch OFF and disconnect negative battery cable. Because battery voltage is applied to TCM even if ignition switch is turned OFF.

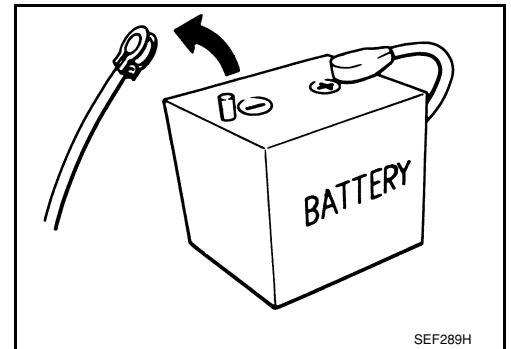

- When connecting or disconnecting pin connectors into or from TCM, take care not to damage pin terminals (bend or break).
When connecting pin connectors make sure that there are not any bends or breaks on TCM pin terminal.

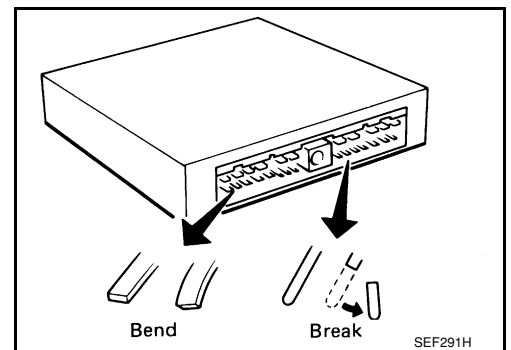

PRECAUTIONS

< SERVICE INFORMATION >

- Before replacing TCM, perform TCM input/output signal inspection and make sure whether TCM functions properly or not. [CVT-45, "TCM Terminal and Reference Value"](#).

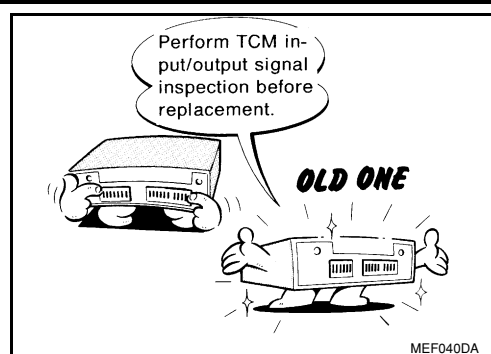

- After performing each TROUBLE DIAGNOSIS, perform “DTC Confirmation Procedure”.
If the repair is completed the DTC should not be displayed in the “DTC Confirmation Procedure”.
- Always use the specified brand of CVT fluid. Refer to [MA-10, "Fluids and Lubricants"](#).
- Use lint-free paper, not cloth rags, during work.
- After replacing the CVT fluid, dispose of the waste oil using the methods prescribed by law, ordinance, etc.

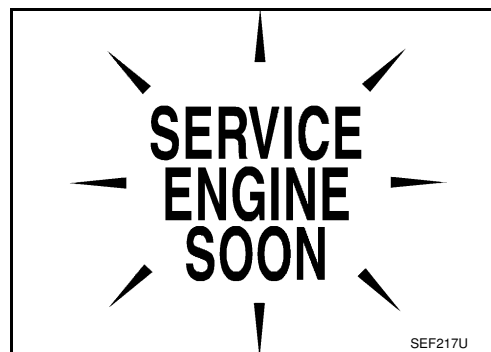

Service Notice or Precaution

INFOID:000000001703430

CVT FLUID COOLER SERVICE

If CVT fluid contains friction material (clutches, brakes, etc.), or if an CVT is replaced, inspect and clean the CVT fluid cooler mounted in the radiator or replace the radiator. Flush cooler lines using cleaning solvent and compressed air after repair. For CVT fluid cooler cleaning procedure, refer to [CVT-14, "CVT Fluid Cooler Cleaning"](#). For radiator replacement, refer to [CO-11](#).

OBD-II SELF-DIAGNOSIS

- CVT self-diagnosis is performed by the TCM in combination with the ECM. The results can be read through the blinking pattern of the malfunction indicator lamp (MIL). Refer to the table on [CVT-47, "CONSULT-III Function \(TRANSMISSION\)"](#) for the indicator used to display each self-diagnostic result.
- The self-diagnostic results indicated by the MIL are automatically stored in both the ECM and TCM memories.

Always perform the procedure on [CVT-26, "OBD-II Diagnostic Trouble Code \(DTC\)"](#) to complete the repair and avoid unnecessary blinking of the MIL.

For details of OBD-II, refer to [EC-46](#).

- **Certain systems and components, especially those related to OBD, may use the new style slide-locking type harness connector. For description and how to disconnect, refer to [PG-65](#).**

PREPARATION

< SERVICE INFORMATION >

PREPARATION

Special Service Tool

INFOID:000000001703431

The actual shapes of Kent-Moore tools may differ from those of special service tools illustrated here.

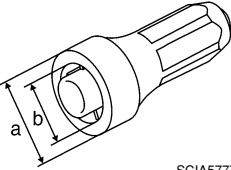
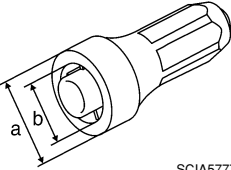
Tool number (Kent-Moore No.) Tool name	Description
<p>— (OTC3492) Oil pressure gauge set</p>  <p style="text-align: right;">SCIA7531E</p>	<p>Measuring line pressure</p>
<p>— (J-47244) Drift</p>  <p style="text-align: right;">SCIA5777E</p>	<p>Installing differential side oil seal</p> <ul style="list-style-type: none"> • Transaxle case side (left) <p>a: 65.83 mm (2.59 in) dia. b: 53.85 mm (2.12 in) dia.</p>
<p>ST33400001 (J-47005) Drift</p>  <p style="text-align: right;">SCIA5777E</p>	<p>Installing differential side oil seal</p> <ul style="list-style-type: none"> • Converter housing side (right) <p>a: 69.85 mm (2.75 in) dia. b: 49.53 mm (1.95 in) dia.</p>

Commercial Service Tool

INFOID:000000001703432

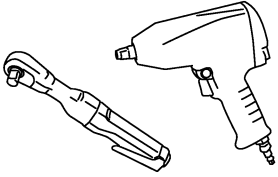
Tool number Tool name	Description
<p>Power tool</p>  <p style="text-align: right;">PBIC0190E</p>	<p>Loosening nuts and bolts</p>

CVT FLUID

< SERVICE INFORMATION >

CVT FLUID

Checking CVT Fluid

INFOID:000000001703433

FLUID LEVEL CHECK

Fluid level should be checked with the fluid warmed up to 50 to 80°C (122 to 176°F).

1. Check for fluid leakage.
2. With the engine warmed up, drive the vehicle to warm up the CVT fluid. When ambient temperature is 20°C (68°F), it takes about 10 minutes for the CVT fluid to warm up to 50 to 80°C (122 to 176°F).
3. Park the vehicle on a level surface and set the parking brake.
4. With engine at idle, while depressing brake pedal, move the selector lever throughout the entire shift range and return it to the "P" position.

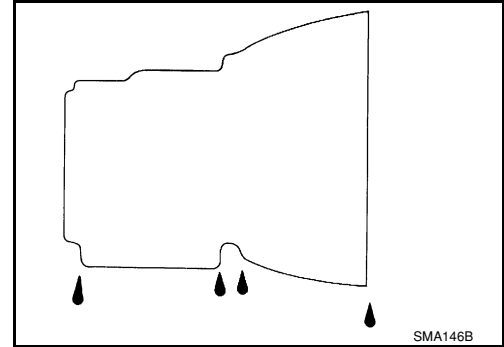

5. Press the tab on the CVT fluid level gauge to release the lock and pull out the CVT fluid level gauge from the CVT fluid charging pipe.

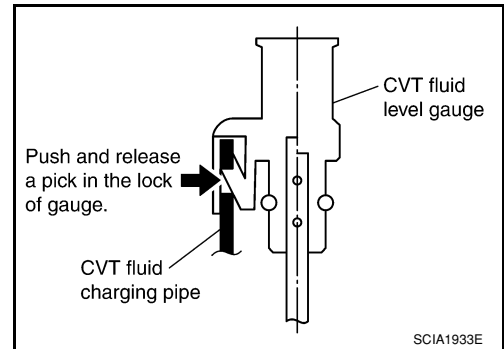

6. Wipe fluid off the CVT fluid level gauge. Then rotate the CVT fluid level gauge 180° and re-insert it into the CVT charging pipe as far as it will go.

CAUTION:

Always use lint free paper towels to wipe fluid off the CVT fluid level gauge.

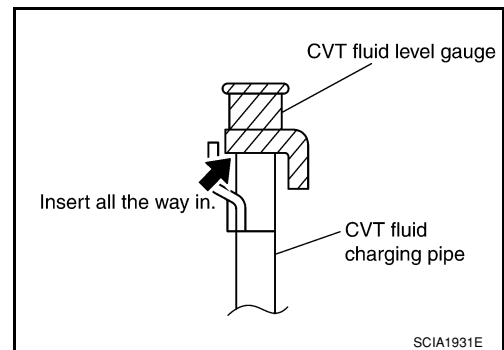

7. Remove the CVT fluid level gauge and check that the fluid level is within the specified range as shown. If the fluid level is at or below the low side of the range, add the necessary specified NISSAN CVT fluid through the CVT charging pipe.

Fluid grade: Refer to [MA-10, "Fluids and Lubricants"](#).

CAUTION:

- Only use specified NISSAN CVT fluid.
- Do not overfill the CVT.

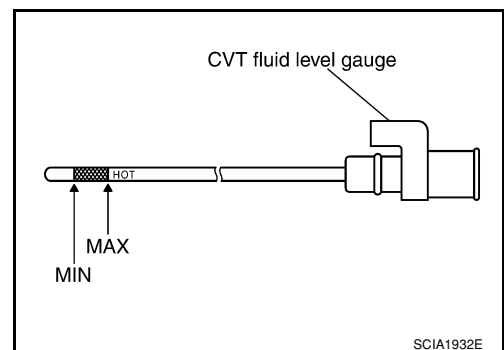

8. Install the CVT fluid level gauge to the CVT fluid charging pipe until it locks.

CAUTION:

When CVT fluid level gauge is installed into the CVT fluid charging pipe, make sure that the CVT fluid level gauge is securely locked in place.

A
B
CVT
D
E
F
G
H
I
J
K
L
M
N
O
P

CVT FLUID

< SERVICE INFORMATION >

FLUID CONDITION CHECK

Fluid status	Conceivable cause	Required operation
Varnished (viscous varnish state)	Clutch, brake scorched	Replace the CVT fluid and check the CVT main unit and the vehicle for malfunctions (wire harness, cooler pipes, etc.)
Milky white or cloudy	Water in the fluid	Replace the CVT fluid and check for places where water is getting in.
Large amount of metal powder mixed in fluid	Unusual wear of sliding parts within CVT	Replace the CVT fluid and check for improper operation of the CVT.

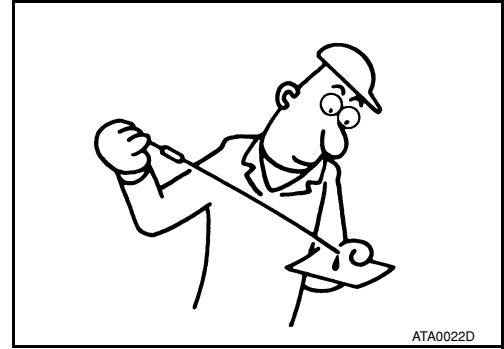

Changing CVT Fluid

INFOID:000000001703434

- Warm up CVT fluid by driving the vehicle for 10 minutes.
 - ↔: Vehicle front
 - Radiator (2)
 - CVT fluid cooler hose [inlet side (3)]
 - Transaxle assembly (4)
- Drain CVT fluid from CVT fluid cooler hose [outlet side (1)] and refill with new specified NISSAN CVT fluid in the CVT fluid charging pipe with the engine running at idle speed.

Fluid capacity and grade: Refer to [MA-10, "Fluids and Lubricants"](#).

CAUTION:

Only use the specified NISSAN CVT fluid.

- Refill until new CVT fluid comes out from CVT fluid cooler hose [outlet side (1)].

NOTE:

About 30 to 50% extra fluid will be required for this procedure.

- Check fluid level and condition. Refer to [MA-19, "Checking CVT Fluid"](#).

CAUTION:

Delete CVT fluid deterioration date with CONSULT-III after changing CVT fluid. Refer to [CVT-47, "CONSULT-III Function \(TRANSMISSION\)"](#).

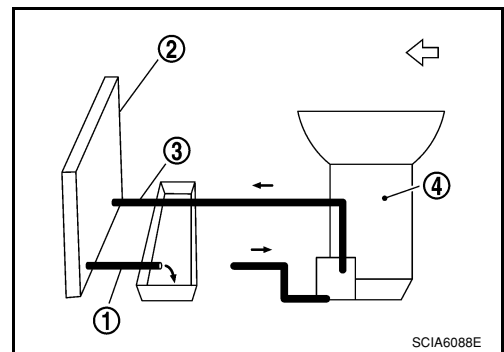

CVT Fluid Cooler Cleaning

INFOID:000000001703435

Whenever a CVT is repaired, overhauled, or replaced, the CVT fluid cooler mounted in the radiator must be inspected and cleaned.

Metal debris and friction material, if present, can be trapped or become deposit in the CVT fluid cooler. This debris can contaminate the newly serviced CVT or, in severe cases, can block or restrict the flow of CVT fluid. In either case, malfunction of the newly serviced CVT may occur.

Debris, if present, may deposit as CVT fluid enters the cooler inlet. It will be necessary to back flush the cooler through the cooler outlet in order to flush out any built up debris.

CVT FLUID COOLER CLEANING PROCEDURE

- Identify the CVT inlet and outlet fluid cooler hoses.
- Position an oil pan under the inlet and outlet cooler hoses.

CVT FLUID

< SERVICE INFORMATION >

3. Disconnect the fluid cooler inlet and outlet rubber hoses from the steel cooler tubes.

NOTE:

Replace the cooler hoses if rubber material from the hose remains on the tube fitting.

4. Allow any CVT fluid that remains in the cooler hoses to drain into the oil pan.

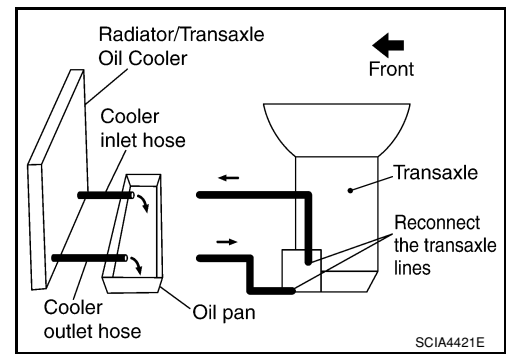

5. Insert the extension adapter hose of a can of Transmission Cooler Cleaner (Nissan P/N 999MP-AM006) into the cooler outlet hose.

CAUTION:

- **Wear safety glasses and rubber gloves when spraying the Transmission Cooler Cleaner.**
- **Spray Transmission Cooler Cleaner only with adequate ventilation.**
- **Avoid contact with eyes and skin.**
- **Do not breath vapors or spray mist.**

6. Hold the hose and can as high as possible and spray Transmission Cooler Cleaner in a continuous stream into the cooler outlet hose until CVT fluid flows out of the cooler inlet hose for 5 seconds.

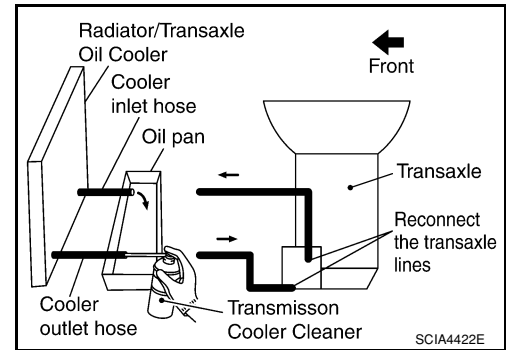

7. Insert the tip of an air gun into the end of the cooler outlet hose.

8. Wrap a shop rag around the air gun tip and of the cooler outlet hose.

9. Blow compressed air regulated to 5 to 9 kg/cm² (70 to 130 psi) through the cooler outlet hose for 10 seconds to force out any remaining CVT fluid.

10. Repeat steps 5 through 9 three additional times.

11. Position an oil pan under the banjo bolts that connect the CVT fluid cooler steel lines to the transaxle.

12. Remove the banjo bolts.

13. Flush each steel line from the cooler side back toward the transaxle by spraying Transmission Cooler Cleaner in a continuous stream for 5 seconds.

14. Blow compressed air regulated to 5 to 9 kg/cm² (70 to 130 psi) through each steel line from the cooler side back toward the transaxle for 10 seconds to force out any remaining CVT fluid.

15. Ensure all debris is removed from the steel cooler lines.

16. Ensure all debris is removed from the banjo bolts and fittings.

17. Perform "CVT FLUID COOLER DIAGNOSIS PROCEDURE".

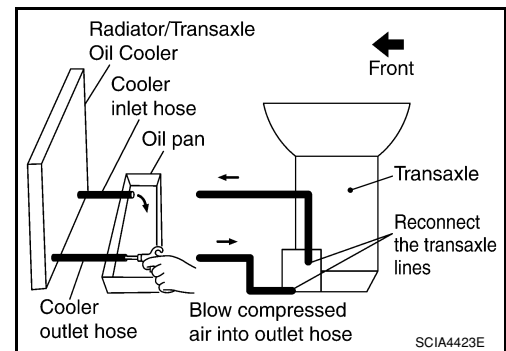

CVT FLUID COOLER DIAGNOSIS PROCEDURE

NOTE:

Insufficient cleaning of the cooler inlet hose exterior may lead to inaccurate debris identification.

1. Position an oil pan under the transaxle's inlet and outlet cooler hoses.
2. Clean the exterior and tip of the cooler inlet hose.

CVT FLUID

< SERVICE INFORMATION >

3. Insert the extension adapter hose of a can of Transmission Cooler Cleaner (Nissan P/N 999MP-AM006) into the cooler outlet hose.

CAUTION:

- **Wear safety glasses and rubber gloves when spraying the Transmission Cooler Cleaner.**
 - **Spray Transmission Cooler Cleaner only with adequate ventilation.**
 - **Avoid contact with eyes and skin.**
 - **Do not breath vapors or spray mist.**
4. Hold the hose and can as high as possible and spray Transmission Cooler Cleaner in a continuous stream into the cooler outlet hose until CVT fluid flows out of the cooler inlet hose for 5 seconds.
 5. Tie a common white, basket-type coffee filter to the end of the cooler inlet hose.

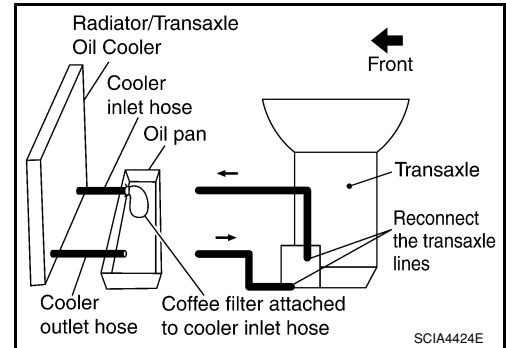
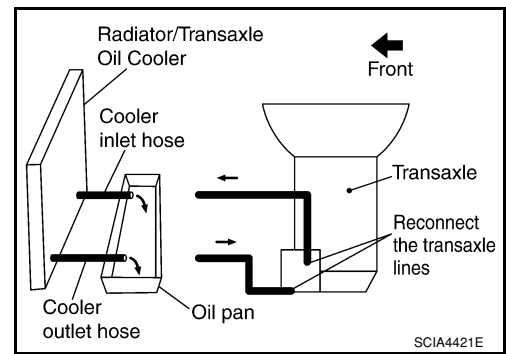

6. Insert the tip of an air gun into the end of the cooler outlet hose.
7. Wrap a shop rag around the air gun tip and end of cooler outlet hose.
8. Blow compressed air regulated to 5 to 9 kg/cm² (70 to 130 psi) through the cooler outlet hose to force any remaining CVT fluid into the coffee filter.
9. Remove the coffee filter from the end of the cooler inlet hose.
10. Perform "CVT FLUID COOLER INSPECTION PROCEDURE".

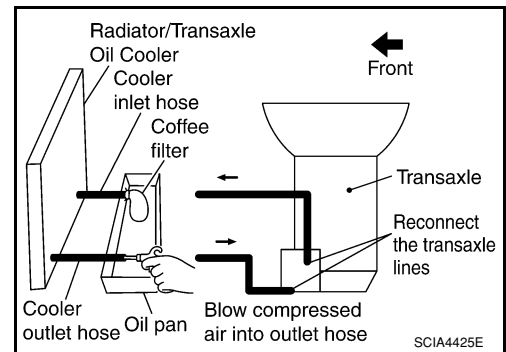

CVT FLUID COOLER INSPECTION PROCEDURE

1. Inspect the coffee filter for debris.
 - a. If small metal debris less than 1 mm (0.040 in) in size or metal powder is found in the coffee filter, this is normal. If normal debris is found, the CVT fluid cooler/radiator can be re-used and the procedure is ended.

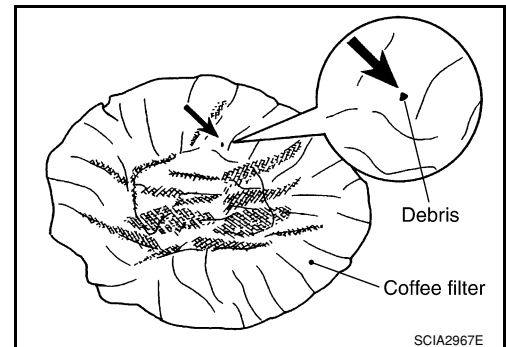

CVT FLUID

< SERVICE INFORMATION >

- b. If one or more pieces of debris are found that are over 1 mm (0.040 in) in size and/or peeled clutch facing material is found in the coffee filter, the fluid cooler is not serviceable. The radiator/fluid cooler must be replaced and the inspection procedure is ended.

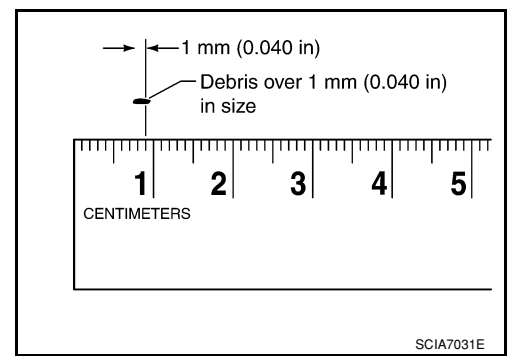

CVT FLUID COOLER FINAL INSPECTION

After performing all procedures, ensure that all remaining oil is cleaned from all components.

A
B
CVT
D
E
F
G
H
I
J
K
L
M
N
O
P

CVT SYSTEM

< SERVICE INFORMATION >

CVT SYSTEM

Cross-Sectional View - RE0F08A

INFOID:000000001703436

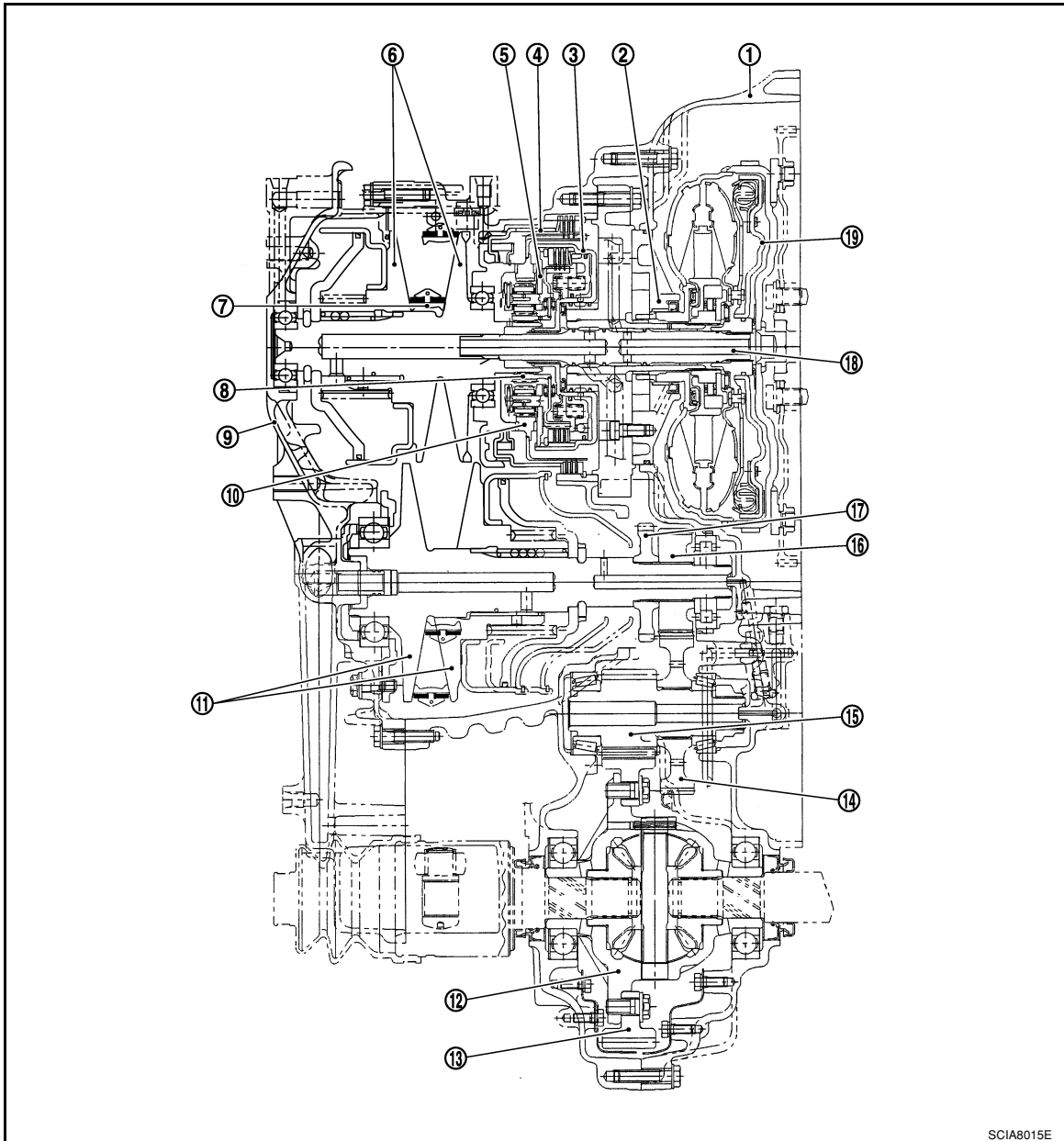

SCIA8015E

- | | | |
|----------------------|----------------------|-----------------------|
| 1. Converter housing | 2. Oil pump | 3. Forward clutch |
| 4. Reverse brake | 5. Planetary carrier | 6. Primary pulley |
| 7. Steel belt | 8. Sun gear | 9. Side cover |
| 10. Internal gear | 11. Secondary pulley | 12. Differential case |
| 13. Final gear | 14. Idler gear | 15. Reduction gear |
| 16. Output gear | 17. Parking gear | 18. Input shaft |
| 19. Torque converter | | |

CVT SYSTEM

< SERVICE INFORMATION >

Control System

INFOID:000000001703437

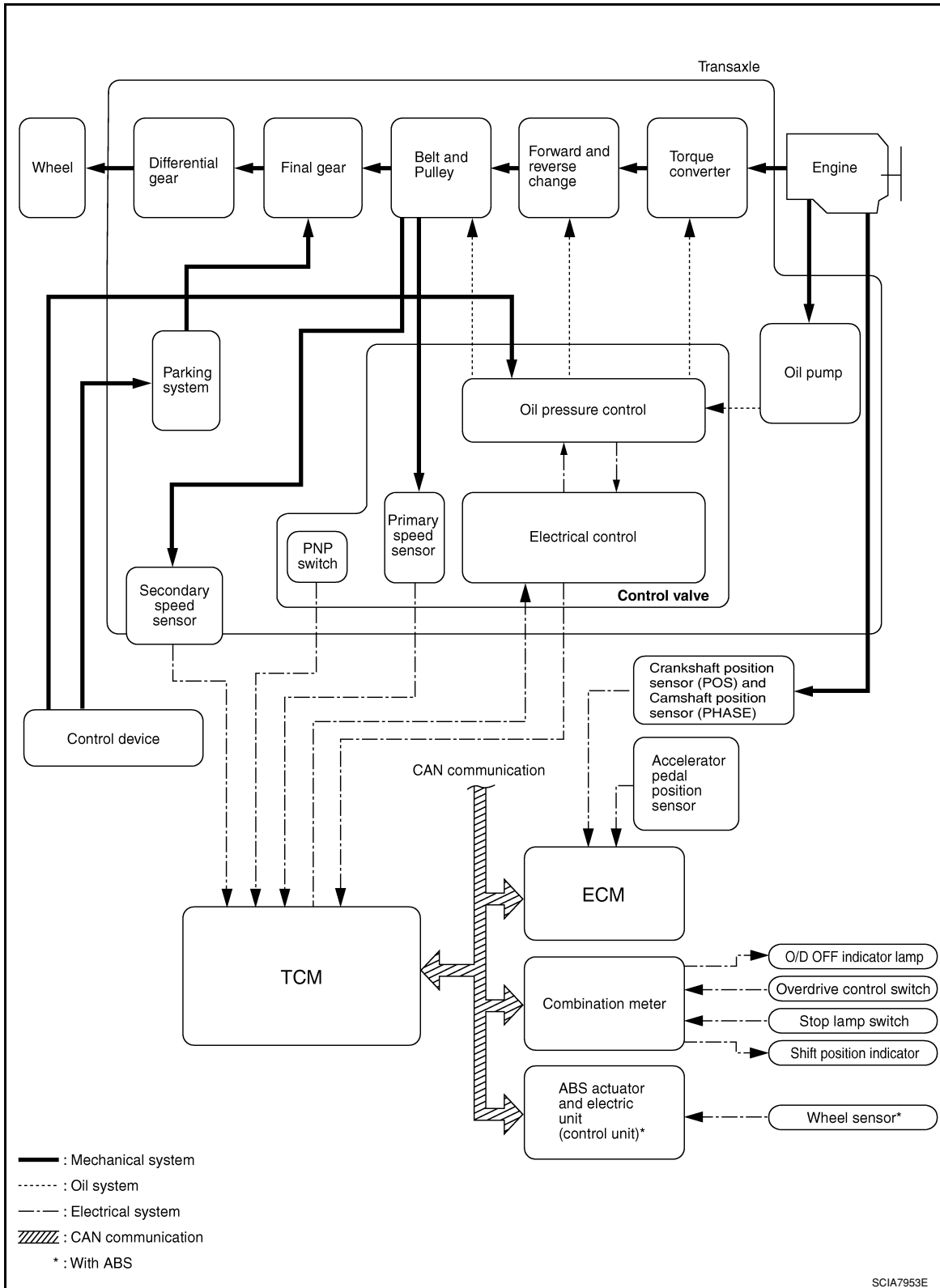

SCIA7953E

A
B
C
D
E
F
G
H
I
J
K
L
M
N
O
P

CVT

CVT SYSTEM

< SERVICE INFORMATION >

Hydraulic Control System

INFOID:000000001703439

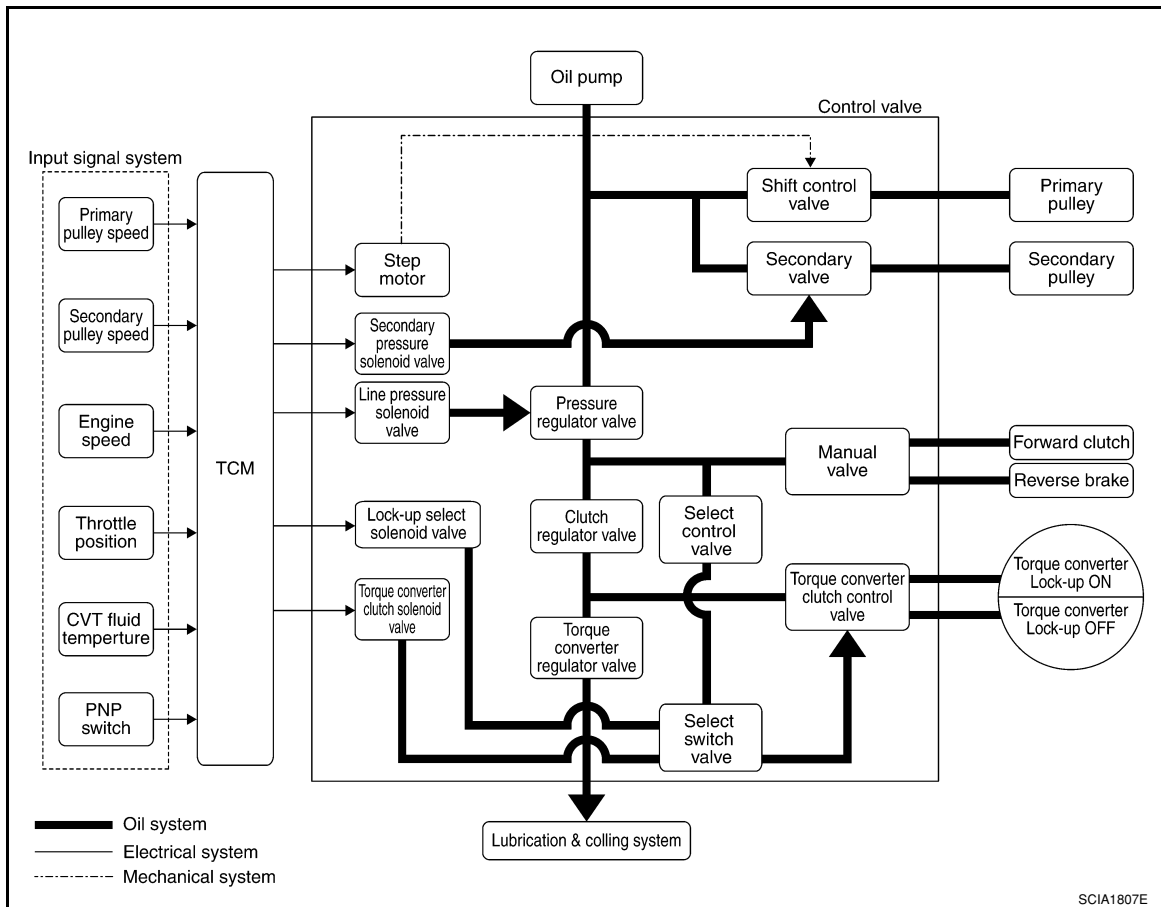

TCM Function

INFOID:000000001703439

The function of the TCM is to:

- Receive input signals sent from various switches and sensors.
- Determine required line pressure, shifting point, and lock-up operation.
- Send required output signals to the step motor and the respective solenoids.

CONTROL SYSTEM OUTLINE

The CVT senses vehicle operating conditions through various sensors. It always controls the optimum shift position and reduces shifting and lock-up shocks.

SENSORS (or SIGNAL)		TCM		ACTUATORS
PNP switch Accelerator pedal position signal Closed throttle position signal Engine speed signal CVT fluid temperature sensor Vehicle speed signal Overdrive control signal Stop lamp switch signal Primary speed sensor Secondary speed sensor Primary pressure sensor Secondary pressure sensor	⇒	Shift control Line pressure control Primary pressure control Secondary pressure control Lock-up control Engine brake control Vehicle speed control Fail-safe control Self-diagnosis CONSULT-III communication line Duet-EA control CAN system On board diagnosis	⇒	Step motor Torque converter clutch solenoid valve Lock-up select solenoid valve Line pressure solenoid valve Secondary pressure solenoid valve Shift position indicator O/D OFF indicator lamp Starter relay

CVT SYSTEM

< SERVICE INFORMATION >

CONTROL SYSTEM DIAGRAM

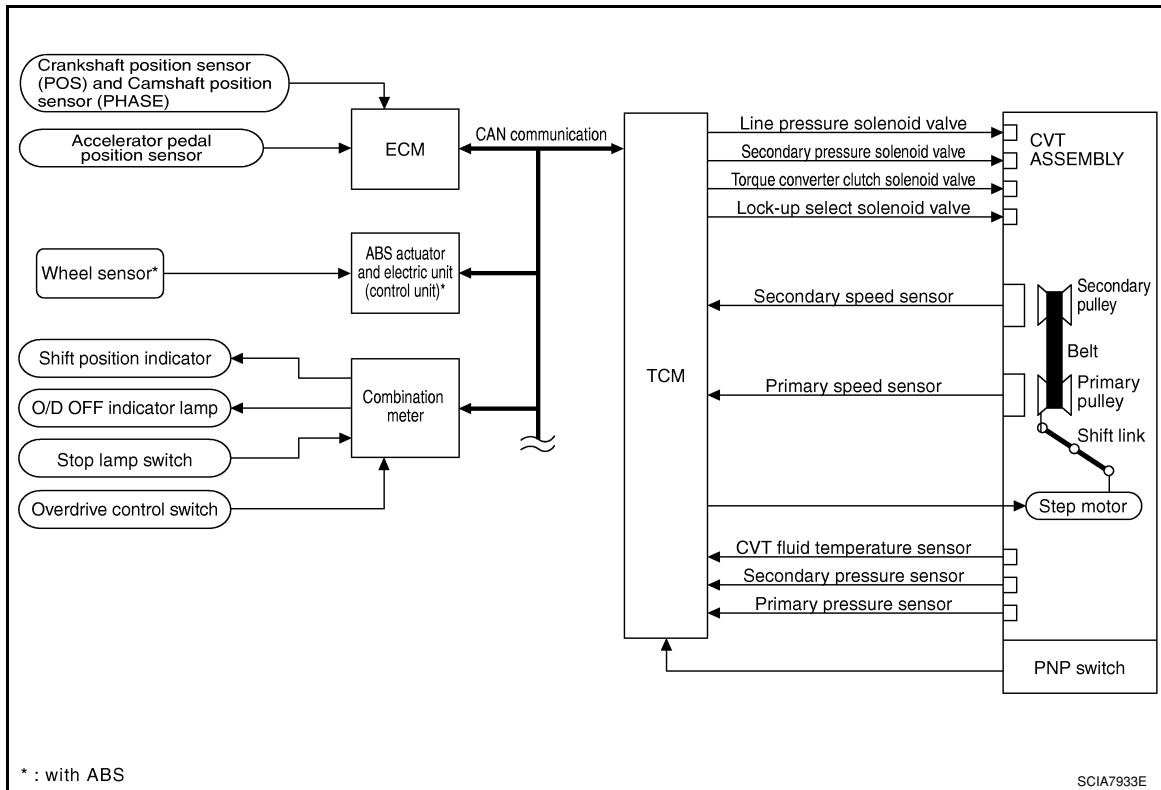

CAN Communication

INFOID:000000001703440

SYSTEM DESCRIPTION

CAN (Controller Area Network) is a serial communication line for real time application. It is an on-vehicle multiplex communication line with high data communication speed and excellent error detection ability. Many electronic control units are equipped onto a vehicle, and each control unit shares information and links with other control units during operation (not independent). In CAN communication, control units are connected with 2 communication lines (CAN-H line, CAN-L line) allowing a high rate of information transmission with less wiring. Each control unit transmits/receives data but selectively reads required data only. For details, refer to [LAN-6](#). "[System Description](#)".

CVT SYSTEM

< SERVICE INFORMATION >

Input/Output Signal of TCM

INFOID:000000001703441

Control item		Fluid pressure control	Select control	Shift control	Lock-up control	CAN communication control	Fail-safe function (*3)
Input	PNP switch	X	X	X	X	X	X
	Accelerator pedal position signal (*1)	X	X	X	X	X	X
	Closed throttle position signal(*1)	X		X	X	X	
	Engine speed signal(*1)	X	X		X	X	X
	CVT fluid temperature sensor	X	X	X	X		X
	Stop lamp switch signal(*1)	X		X	X	X	
	Overdrive control signal(*1)			X		X	
	Primary speed sensor	X		X	X	X	X
	Secondary speed sensor	X	X	X	X	X	X
	Primary pressure sensor	X		X			
	Secondary pressure sensor	X		X			X
	TCM power supply voltage signal	X	X	X	X	X	X
Output	Step motor			X			X
	TCC solenoid valve		X		X		X
	Lock-up select solenoid valve		X		X		X
	Line pressure solenoid valve	X	X	X			X
	Secondary pressure solenoid valve	X		X			X
	O/D OFF indicator signal(*2)			X		X	

*1: Input by CAN communications.

*2: Output by CAN communications.

*3: If these input and output signals are different, the TCM triggers the fail-safe function.

Line Pressure and Secondary Pressure Control

INFOID:000000001703442

- When an input torque signal equivalent to the engine drive force is sent from the ECM to the TCM, the TCM controls the line pressure solenoid valve and secondary pressure solenoid valve.
- This line pressure solenoid controls the pressure regulator valve as the signal pressure and adjusts the pressure of the operating oil discharged from the oil pump to the line pressure most appropriate to the driving state. Secondary pressure is controlled by decreasing line pressure.

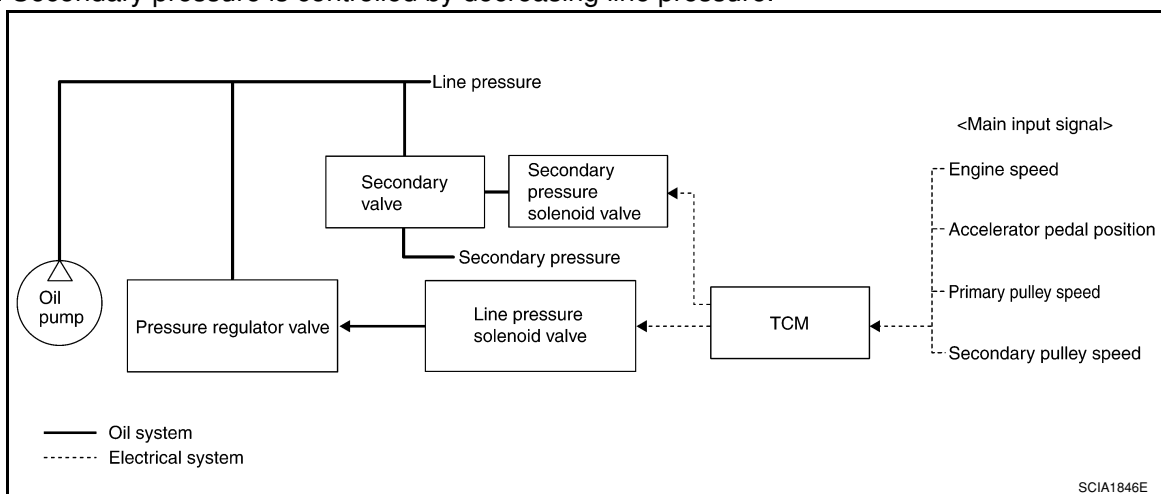

NORMAL CONTROL

CVT SYSTEM

< SERVICE INFORMATION >

Optimize the line pressure and secondary pressure, depending on driving conditions, on the basis of the throttle position, the engine speed, the primary pulley (input) revolution speed, the secondary pulley (output) revolution speed, the brake signal, the PNP switch signal, the lock-up signal, the voltage, the target gear ratio, the fluid temperature, and the fluid pressure.

FEEDBACK CONTROL

When controlling the normal fluid pressure or the selected fluid pressure, the secondary pressure can be set more accurately by using the fluid pressure sensor to detect the secondary pressure and controlling the feedback.

Shift Control

INFOID:000000001703443

In order to select the gear ratio which can obtain the driving force in accordance with driver's intention and the vehicle condition, TCM monitors the driving conditions, such as the vehicle speed and the throttle position and selects the optimum gear ratio, and determines the gear change steps to the gear ratio. Then send the command to the step motor, and control the flow-in/flow-out of line pressure from the primary pulley to determine the position of the moving-pulley and control the gear ratio.

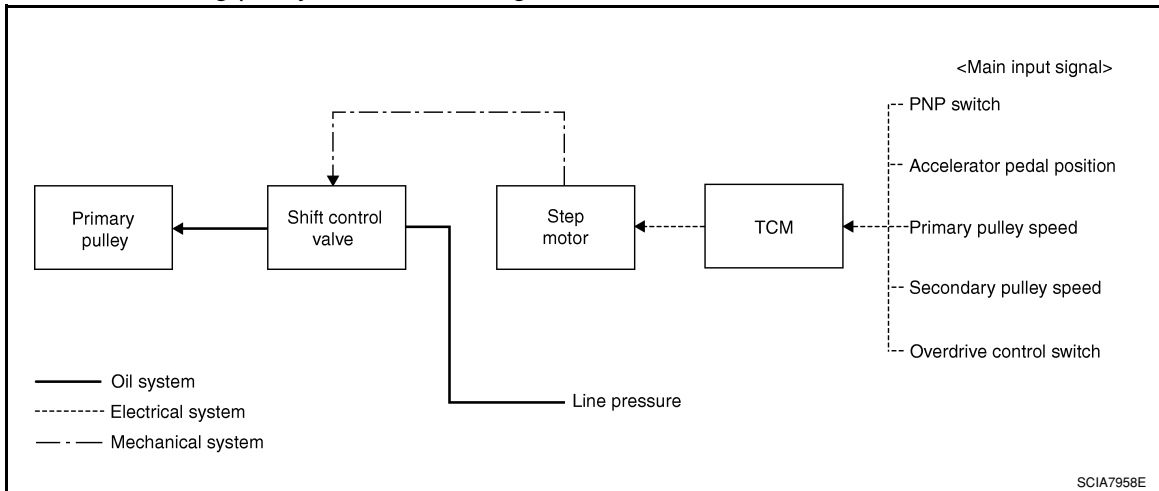

NOTE:

The gear ratio is set for every position separately.

“D” POSITION

Shifting over all the ranges of gear ratios from the lowest to the highest.

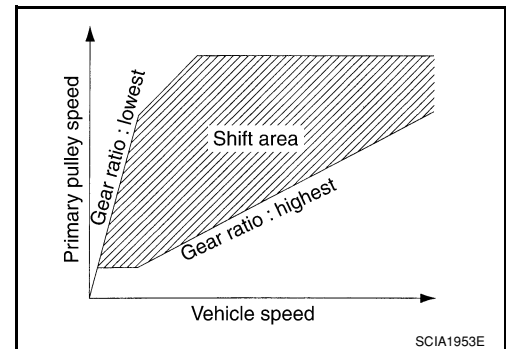

OVERDRIVE-OFF MODE

Use this position for the improved engine braking.

“L” POSITION

CVT SYSTEM

< SERVICE INFORMATION >

By limiting the gear range to the lowest position, the strong driving force and the engine brake can be secured.

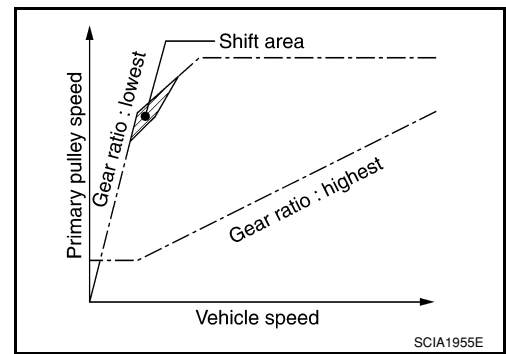

DOWNHILL ENGINE BRAKE CONTROL (AUTO ENGINE BRAKE CONTROL)

When downhill is detected with the accelerator pedal released, the engine brake will be strengthened up by downshifting so as not to accelerate the vehicle more than necessary.

ACCELERATION CONTROL

According to vehicle speed and a change of accelerator pedal angle, driver's request for acceleration and driving scene are judged. This function assists improvement in acceleration feeling by making the engine speed proportionate to the vehicle speed. And a shift map which can gain a larger driving force is available for compatibility of mileage with driveability.

Lock-up and Select Control

INFOID:000000001703444

- The torque converter clutch piston in the torque converter is engaged to eliminate torque converter slip to increase power transmission efficiency.
- The torque converter clutch control valve operation is controlled by the torque converter clutch solenoid valve, which is controlled by a signal from TCM. The torque converter clutch control valve engages or releases the torque converter clutch piston.
- When shifting between "N" ("P") ↔ "D" ("R"), torque converter clutch solenoid controls engagement power of forward clutch and reverse brake.
- The lock-up applied gear range was expanded by locking up the torque converter at a lower vehicle speed than conventional CVT models.

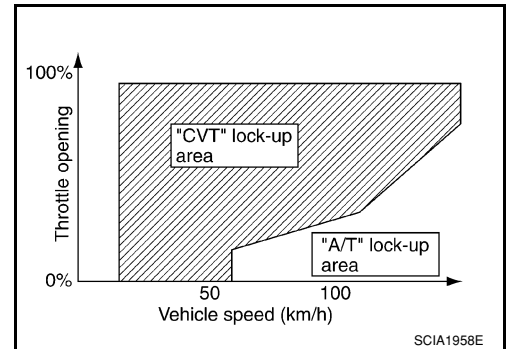

TORQUE CONVERTER CLUTCH AND SELECT CONTROL VALVE CONTROL

CVT SYSTEM

< SERVICE INFORMATION >

Lock-up and Select Control System Diagram

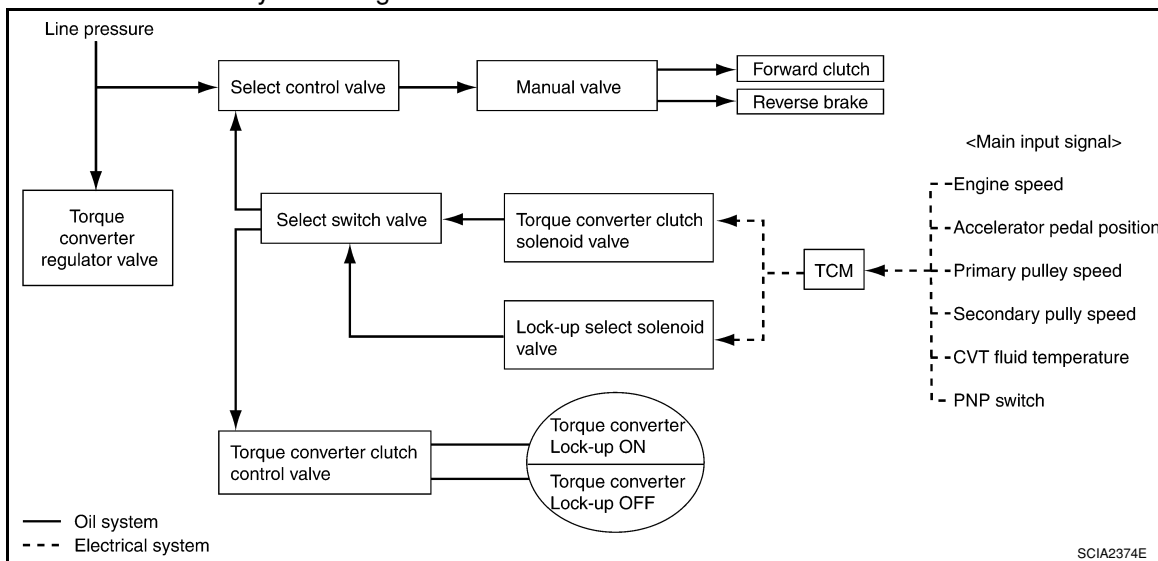

Lock-up Released

In the lock-up released state, the torque converter clutch control valve is set into the unlocked state by the torque converter clutch solenoid and the lock-up apply pressure is drained. In this way, the torque converter clutch piston is not coupled.

Lock-up Applied

In the lock-up applied state, the torque converter clutch control valve is set into the locked state by the torque converter clutch solenoid and lock-up apply pressure is generated. In this way, the torque converter clutch piston is pressed and coupled.

Select Control

When shifting between “N” (“P”) ↔ “D” (“R”), optimize the operating pressure on the basis of the throttle position, the engine speed, and the secondary pulley (output) revolution speed to lessen the shift shock.

Control Valve

INFOID:000000001703445

FUNCTION OF CONTROL VALVE

Name	Function
Torque converter regulator valve	Optimizes the supply pressure for the torque converter depending on driving conditions.
Pressure regulator valve	Optimizes the discharge pressure from the oil pump depending on driving conditions.
TCC control valve	<ul style="list-style-type: none"> Activates or deactivate the lock-up. Lock-up smoothly by opening lock-up operation excessively.
TCC solenoid valve	Controls the TCC control valve or select control valve.
Shift control valve	Controls flow-in/out of line pressure from the primary pulley depending on the stroke difference between the stepping motor and the primary pulley.
Secondary valve	Controls the line pressure from the secondary pulley depending on operating conditions.
Clutch regulator valve	Adjusts the clutch operating pressure depending on operating conditions.
Secondary pressure solenoid valve	Controls the secondary valve.
Line pressure solenoid valve	Controls the line pressure control valve.
Step motor	Controls the pulley ratio.
Manual valve	Transmits the clutch operating pressure to each circuit in accordance with the selected position.
Select control valve	Engages forward clutch, reverse brake smoothly depending on select operation.
Select switch valve	Switches torque converter clutch solenoid valve control pressure use to torque converter clutch control valve or select control valve.
Lock-up select solenoid valve	Controls the select switch valve.

ON BOARD DIAGNOSTIC (OBD) SYSTEM

< SERVICE INFORMATION >

ON BOARD DIAGNOSTIC (OBD) SYSTEM

Introduction

INFOID:000000001703446

The CVT system has two self-diagnostic systems.

The first is the emission-related on board diagnostic system (OBD-II) performed by the TCM in combination with the ECM. The malfunction is indicated by the MIL (malfunction indicator lamp) and is stored as a DTC in the ECM memory, and the TCM memory.

The second is the TCM original self-diagnosis performed by the TCM. The malfunction is stored in the TCM memory. The detected items are overlapped with OBD-II self-diagnostic items. For detail, refer to [CVT-47, "CONSULT-III Function \(TRANSMISSION\)"](#).

OBD-II Function for CVT System

INFOID:000000001703447

The ECM provides emission-related on board diagnostic (OBD-II) functions for the CVT system. One function is to receive a signal from the TCM used with OBD-related parts of the CVT system. The signal is sent to the ECM when a malfunction occurs in the corresponding OBD-related part. The other function is to indicate a diagnostic result by means of the MIL (malfunction indicator lamp) on the instrument panel. Sensors, switches and solenoid valves are used as sensing elements.

The MIL automatically illuminates in One or Two Trip Detection Logic when a malfunction is sensed in relation to CVT system parts.

One or Two Trip Detection Logic of OBD-II

INFOID:000000001703448

ONE TRIP DETECTION LOGIC

If a malfunction is sensed during the first test drive, the MIL will illuminate and the malfunction will be stored in the ECM memory as a DTC. The TCM is not provided with such a memory function.

TWO TRIP DETECTION LOGIC

When a malfunction is sensed during the first test drive, it is stored in the ECM memory as a 1st trip DTC (diagnostic trouble code) or 1st trip freeze frame data. At this point, the MIL will not illuminate. — 1st trip

If the same malfunction as that experienced during the first test drive is sensed during the second test drive, the MIL will illuminate. — 2nd trip

The "trip" in the "One or Two Trip Detection Logic" means a driving mode in which self-diagnosis is performed during vehicle operation.

OBD-II Diagnostic Trouble Code (DTC)

INFOID:000000001703449

HOW TO READ DTC AND 1ST TRIP DTC

DTC and 1st trip DTC can be read by the following methods.

( with **CONSULT-III** or ( **GST**) CONSULT-III or GST (Generic Scan Tool) Examples: P0705, P0720 etc.

These DTC are prescribed by SAE J2012.

(CONSULT-III also displays the malfunctioning component or system.)

- **1st trip DTC No. is the same as DTC No.**
- **Output of the diagnostic trouble code indicates that the indicated circuit has a malfunction. However, in case of the Mode II and GST, they do not indicate whether the malfunction is still occurring or occurred in the past and returned to normal.**
CONSULT-III can identify them as shown below, therefore, CONSULT-III (if available) is recommended.

DTC or 1st trip DTC of a malfunction is displayed in SELF-DIAGNOSTIC RESULTS mode for "ENGINE" with CONSULT-III. Time data indicates how many times the vehicle was driven after the last detection of a DTC.

If the DTC is being detected currently, the time data will be "0".

If a 1st trip DTC is stored in the ECM, the time data will be "1t".

Freeze Frame Data and 1st Trip Freeze Frame Data

ON BOARD DIAGNOSTIC (OBD) SYSTEM

< SERVICE INFORMATION >

The ECM has a memory function, which stores the driving condition such as fuel system status, calculated load value, engine coolant temperature, short term fuel trim, long term fuel trim, engine speed and vehicle speed at the moment the ECM detects a malfunction.

Data which are stored in the ECM memory, along with the 1st trip DTC, are called 1st trip freeze frame data, and the data, stored together with the DTC data, are called freeze frame data and displayed on CONSULT-III or GST. The 1st trip freeze frame data can only be displayed on the CONSULT-III screen, not on the GST. For details, refer to [EC-109. "CONSULT-II Function \(ENGINE\)"](#).

Only one set of freeze frame data (either 1st trip freeze frame data or freeze frame data) can be stored in the ECM. 1st trip freeze frame data is stored in the ECM memory along with the 1st trip DTC. There is no priority for 1st trip freeze frame data, and it is updated each time a different 1st trip DTC is detected. However, once freeze frame data (2nd trip detection/MIL on) is stored in the ECM memory, 1st trip freeze frame data is no longer stored. Remember, only one set of freeze frame data can be stored in the ECM. The ECM has the following priorities to update the data.

Priority	Items	
1	Freeze frame data	Misfire — DTC: P0300 - P0306 Fuel Injection System Function — DTC: P0171, P0172, P0174, P0175
2		Except the above items (Includes CVT related items)
3	1st trip freeze frame data	

Both 1st trip freeze frame data and freeze frame data (along with the DTC) are cleared when the ECM memory is erased.

HOW TO ERASE DTC

The diagnostic trouble code can be erased by CONSULT-III, GST or ECM DIAGNOSTIC TEST MODE as described following.

- **If the battery cable is disconnected, the diagnostic trouble code will be lost within 24 hours.**
- **When you erase the DTC, using CONSULT-III or GST is easier and quicker than switching the mode selector on the ECM.**

The following emission-related diagnostic information is cleared from the ECM memory when erasing DTC related to OBD-II. For details, refer to [EC-47. "Emission-related Diagnostic Information"](#).

- **Diagnostic trouble codes (DTC)**
- **1st trip diagnostic trouble codes (1st trip DTC)**
- **Freeze frame data**
- **1st trip freeze frame data**
- **System readiness test (SRT) codes**
- **Test values**

HOW TO ERASE DTC (WITH CONSULT-III)

- **If a DTC is displayed for both ECM and TCM, it is necessary to be erased for both ECM and TCM.**
1. If the ignition switch stays ON after repair work, be sure to turn ignition switch OFF once. Wait at least 10 seconds and then turn it ON (engine stopped) again.
 2. Turn CONSULT-III ON and touch "TRANSMISSION".
 3. Touch "SELF-DIAG RESULTS".
 4. Touch "ERASE". (The DTC in the TCM will be erased.) Then touch "BACK" twice.
 5. Touch "ENGINE".
 6. Touch "SELF-DIAG RESULTS".
 7. Touch "ERASE". (The DTC in the ECM will be erased.)

HOW TO ERASE DTC (WITH GST)

1. If the ignition switch stays ON after repair work, be sure to turn ignition switch OFF once. Wait at least 10 seconds and then turn it ON (engine stopped) again.
2. Select Mode 4 with GST (Generic Scan Tool). For details, refer to [EC-119. "Generic Scan Tool \(GST\) Function"](#).

Malfunction Indicator Lamp (MIL)

INFOID:000000001703450

DESCRIPTION

ON BOARD DIAGNOSTIC (OBD) SYSTEM

< SERVICE INFORMATION >

The MIL is located on the instrument panel.

1. The MIL will light up when the ignition switch is turned ON without the engine running. This is a bulb check.
 - If the MIL does not light up, refer to [DI-21](#), or see [EC-546](#).
2. When the engine is started, the MIL should go off.
If the MIL remains on, the on board diagnostic system has detected an engine system malfunction.

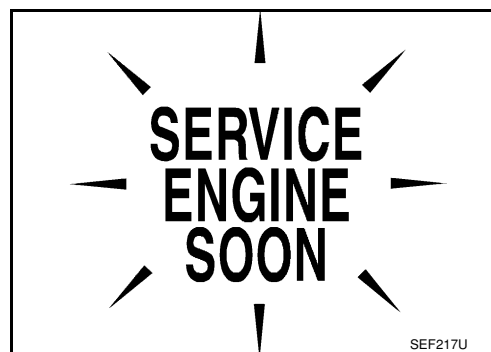

TROUBLE DIAGNOSIS

< SERVICE INFORMATION >

TROUBLE DIAGNOSIS

DTC Inspection Priority Chart

INFOID:000000001703451

If some DTCs are displayed at the same time, perform inspections one by one based on the following priority chart.

NOTE:

If DTC “U1000 CAN COMM CIRCUIT” is displayed with other DTCs, first perform the trouble diagnosis for “DTC U1000 CAN COMMUNICATION LINE”. Refer to [CVT-56](#).

Priority	Detected items (DTC)
1	U1000 CAN communication line
2	Except above

Fail-Safe

INFOID:000000001703452

The TCM has an electrical fail-safe mode. This mode makes it possible to operate even if there is an error in a main electronic control input/output signal circuit.

FAIL-SAFE FUNCTION

If any malfunction occurs in a sensor or solenoid, this function controls the CVT to make driving possible.

Output Speed Sensor (Secondary Speed Sensor)

The shift pattern is changed in accordance with throttle position when an unexpected signal is sent from the output speed sensor (secondary speed sensor) to the TCM. The overdrive-off mode is inhibited, and the transaxle is put in “D”.

Input Speed Sensor (Primary Speed Sensor)

The shift pattern is changed in accordance with throttle position and secondary speed (vehicle speed) when an unexpected signal is sent from the input speed sensor (primary speed sensor) to the TCM. The sport mode is inhibited, and the transaxle is put in “D”.

PNP Switch

If an unexpected signal is sent from the PNP switch to the TCM, the transaxle is put in “D”.

CVT Fluid Temperature Sensor

If an unexpected signal is sent from the CVT fluid temperature sensor to the TCM, the gear ratio in use before receiving the unexpected signal is maintained or the gear ratio is controlled to keep engine speed under 3500 rpm.

Transmission Fluid Pressure Sensor A (Secondary Pressure Sensor)

- If an unexpected signal is sent from the transmission fluid pressure sensor A (secondary pressure sensor) to the TCM, the secondary pressure feedback control is stopped and the offset value obtained before the non-standard condition occurs is used to control line pressure.
- If transmission fluid pressure sensor A (secondary pressure sensor) error signal is input to TCM, secondary pressure feedback control stops, but line pressure is controlled normally.

Pressure Control Solenoid A (Line Pressure Solenoid)

If an unexpected signal is sent from the solenoid to the TCM, the pressure control solenoid A (line pressure solenoid) is turned OFF to achieve the maximum fluid pressure.

Pressure Control Solenoid B (Secondary Pressure Solenoid)

If an unexpected signal is sent from the solenoid to the TCM, the pressure control solenoid B (secondary pressure solenoid) is turned OFF to achieve the maximum fluid pressure.

Torque Converter Clutch Solenoid

If an unexpected signal is sent from the solenoid to the TCM, the torque converter clutch solenoid is turned OFF to cancel the lock-up.

Step Motor

If an unexpected signal is sent from the step motor to the TCM, the step motor coil phases “A” through “D” are all turned OFF to hold the gear ratio used right before the non-standard condition occurred.

CVT Lock-up Select Solenoid

TROUBLE DIAGNOSIS

< SERVICE INFORMATION >

If an unexpected signal is sent from the solenoid to the TCM, the CVT lock-up select solenoid is turned OFF to cancel the lock-up.

TCM Power Supply (Memory Back-up)

Transaxle assembly is protected by limiting the engine torque when the memory back-up power supply (for controlling) from the battery is not supplied to TCM. Normal status is restored when turning the ignition switch OFF to ON after the normal power supply.

How to Perform Trouble Diagnosis for Quick and Accurate Repair

INFOID:000000001703453

INTRODUCTION

The TCM receives a signal from the vehicle speed sensor, PNP switch and provides shift control or lock-up control via CVT solenoid valves.

The TCM also communicates with the ECM by means of a signal sent from sensing elements used with the OBD-related parts of the CVT system for malfunction-diagnostic purposes. The TCM is capable of diagnosing malfunctioning parts while the ECM can store malfunctions in its memory.

Input and output signals must always be correct and stable in the operation of the CVT system. The CVT system must be in good operating condition and be free of valve seizure, solenoid valve malfunction, etc.

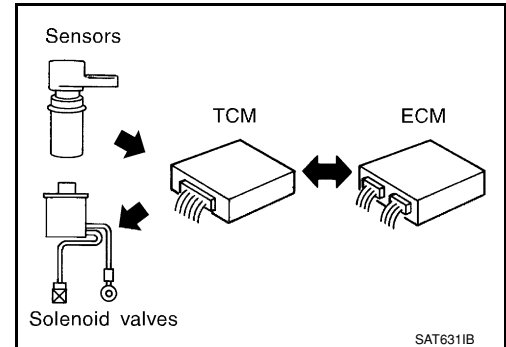

It is much more difficult to diagnose an error that occurs intermittently rather than continuously. Most intermittent errors are caused by poor electric connections or improper wiring. In this case, careful checking of suspected circuits may help prevent the replacement of good parts.

A visual check only may not find the cause of the errors. A road test with CONSULT-III (or GST) or a circuit tester connected should be performed. Follow the "WORK FLOW" .

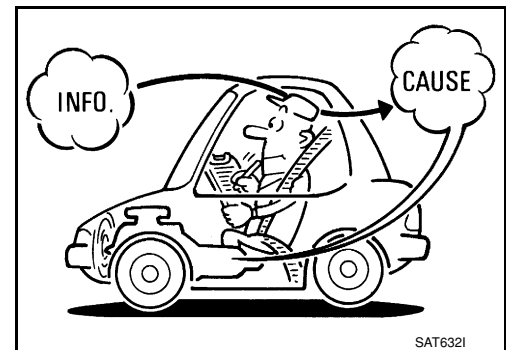

Before undertaking actual checks, take a few minutes to talk with a customer who approaches with a driveability complaint. The customer can supply good information about such errors, especially intermittent ones. Find out what symptoms are present and under what conditions they occur. A "DIAGNOSTIC WORKSHEET" as shown on the example (Refer to "Diagnostic Worksheet Chart") should be used.

Start your diagnosis by looking for "conventional" errors first. This will help troubleshoot driveability errors on an electronically controlled engine vehicle.

Also check related Service bulletins.

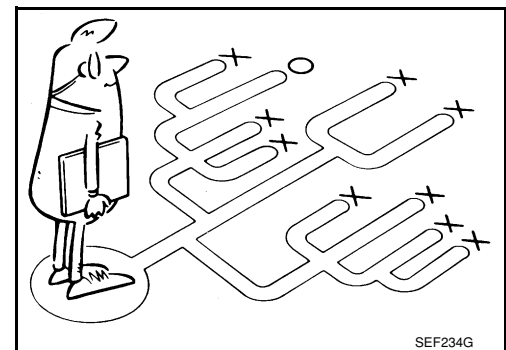

WORK FLOW

A good understanding of the malfunction conditions can make troubleshooting faster and more accurate. In general, each customer feels differently about a malfunction. It is important to fully understand the symptoms or conditions for a customer complaint.

Make good use of the two sheets provided, "Information From Customer" and "Diagnostic Worksheet Chart" , to perform the best troubleshooting possible.

Work Flow Chart

TROUBLE DIAGNOSIS

< SERVICE INFORMATION >

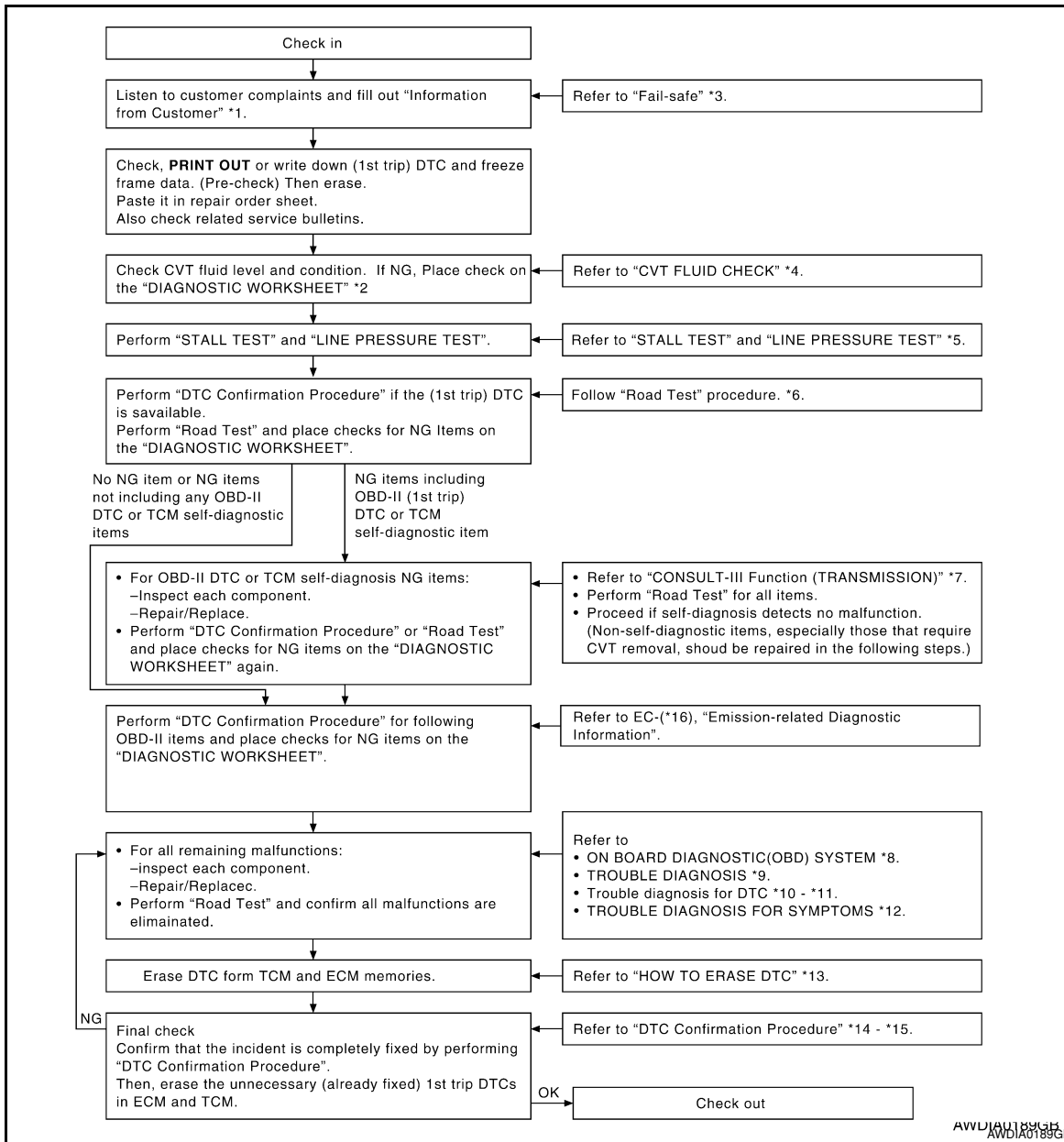

- | | | |
|---------------------------------|---|------------------------------|
| *1. "Information From Customer" | *2. "DIAGNOSTIC WORKSHEET" | *3. CVT-29 |
| *4. CVT-36 | *5. CVT-36 , CVT-36 | *6. CVT-40 |
| *7. CVT-47 | *8. CVT-26 | *9. CVT-29 |
| *10. CVT-56 | *11. CVT-141 | *12. CVT-149 |
| *13. CVT-26 | *14. CVT-56 | *15. CVT-141 |
| *16. EC-47 | | |

DIAGNOSTIC WORKSHEET

Information From Customer

KEY POINTS

- **WHAT**..... Vehicle & CVT model
- **WHEN**..... Date, Frequencies
- **WHERE**..... Road conditions
- **HOW**..... Operating conditions, Symptoms

TROUBLE DIAGNOSIS

< SERVICE INFORMATION >

		<input type="checkbox"/> Perform road test.	CVT-40	A
4	4-1.	Check before engine is started	CVT-41	B
		<input type="checkbox"/> CVT-151. "O/D OFF Indicator Lamp Does Not Come On"		B
		<input type="checkbox"/> Perform self-diagnosis. Enter checks for detected items. CVT-47		B
		<input type="checkbox"/> CVT-56 <input type="checkbox"/> CVT-60 <input type="checkbox"/> CVT-63 <input type="checkbox"/> CVT-65 <input type="checkbox"/> CVT-71 <input type="checkbox"/> CVT-76 <input type="checkbox"/> CVT-80 <input type="checkbox"/> CVT-85 <input type="checkbox"/> CVT-87 <input type="checkbox"/> CVT-88 <input type="checkbox"/> CVT-93 <input type="checkbox"/> CVT-95 <input type="checkbox"/> CVT-100 <input type="checkbox"/> CVT-102 <input type="checkbox"/> CVT-104 <input type="checkbox"/> CVT-109 <input type="checkbox"/> CVT-113 <input type="checkbox"/> CVT-115 <input type="checkbox"/> CVT-119 <input type="checkbox"/> CVT-121 <input type="checkbox"/> CVT-125 <input type="checkbox"/> CVT-127 <input type="checkbox"/> CVT-129 <input type="checkbox"/> CVT-131 <input type="checkbox"/> CVT-132 <input type="checkbox"/> CVT-137 <input type="checkbox"/> CVT-141		D E F G H I
		Check at idle	CVT-41	J
	4-2.	<input type="checkbox"/> CVT-153. "Engine Cannot Be Started in "P" and "N" Position" <input type="checkbox"/> CVT-153. "In "P" Position. Vehicle Moves Forward or Backward When Pushed" <input type="checkbox"/> CVT-154. "In "N" Position. Vehicle Moves" <input type="checkbox"/> CVT-154. "Large Shock "N" → "R" Position" <input type="checkbox"/> CVT-155. "Vehicle Does Not Creep Backward in "R" Position" <input type="checkbox"/> CVT-156. "Vehicle Does Not Creep Forward in "D" or "L" Position"		K

CVT

TROUBLE DIAGNOSIS

< SERVICE INFORMATION >

4	4-3.	Cruise test	CVT-43
		<input type="checkbox"/> CVT-157. "Vehicle Speed Does Not Change in "L" Position" <input type="checkbox"/> CVT-158. "Vehicle Speed Does Not Change in overdrive-off mode" <input type="checkbox"/> CVT-159. "Vehicle Speed Does Not Change in "D" Position" <input type="checkbox"/> CVT-159. "Vehicle Does Not Decelerate by Engine Brake" <input type="checkbox"/> perform self-diagnosis. Enter checks for detected items. CVT-47	
		<input type="checkbox"/> CVT-56 <input type="checkbox"/> CVT-60 <input type="checkbox"/> CVT-63 <input type="checkbox"/> CVT-65 <input type="checkbox"/> CVT-71 <input type="checkbox"/> CVT-76 <input type="checkbox"/> CVT-80 <input type="checkbox"/> CVT-85 <input type="checkbox"/> CVT-87 <input type="checkbox"/> CVT-88 <input type="checkbox"/> CVT-93 <input type="checkbox"/> CVT-95 <input type="checkbox"/> CVT-100 <input type="checkbox"/> CVT-102 <input type="checkbox"/> CVT-104 <input type="checkbox"/> CVT-109 <input type="checkbox"/> CVT-113 <input type="checkbox"/> CVT-115 <input type="checkbox"/> CVT-119 <input type="checkbox"/> CVT-121 <input type="checkbox"/> CVT-125 <input type="checkbox"/> CVT-127 <input type="checkbox"/> CVT-129 <input type="checkbox"/> CVT-131 <input type="checkbox"/> CVT-132 <input type="checkbox"/> CVT-137 <input type="checkbox"/> CVT-141	
5		<input type="checkbox"/> Inspect each system for items found to be NG in the self-diagnosis and repair or replace the malfunctioning parts.	
6		<input type="checkbox"/> Perform all road tests and enter the checks again for the required items.	CVT-40
7		<input type="checkbox"/> For any remaining NG items, perform the "diagnosis procedure" and repair or replace the malfunctioning parts.	
8		<input type="checkbox"/> Erase the results of the self-diagnosis from the TCM.	CVT-26 , CVT-26

TROUBLE DIAGNOSIS

< SERVICE INFORMATION >

CVT Electrical Parts Location

INFOID:000000001703454

A
B
CVT
D
E
F
G
H
I
J
K
L
M
N
O
P

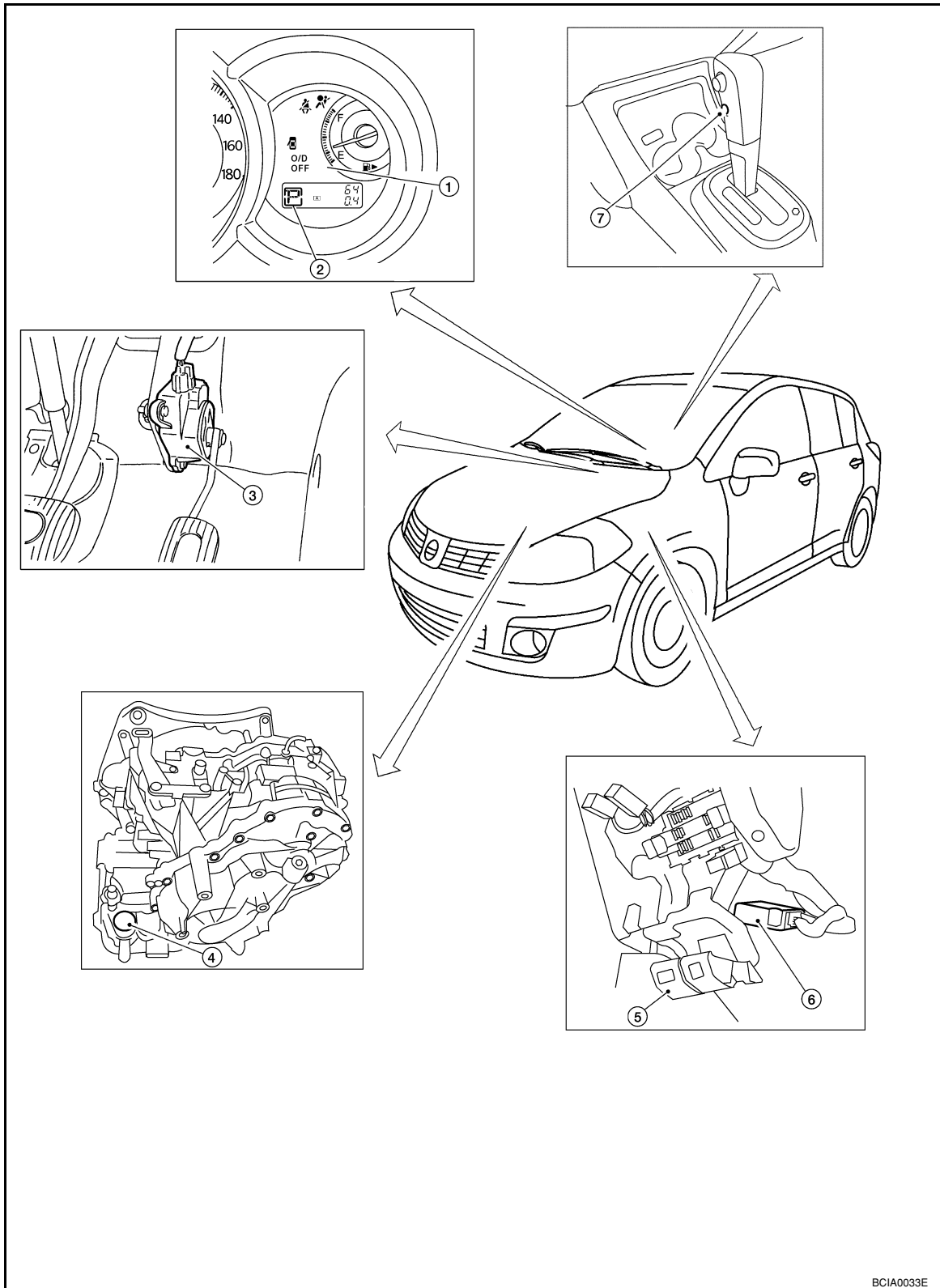

BCIA0033E

- | | | |
|-------------------------------|-----------------------------|--------------------------------------|
| 1. O/D OFF indicator lamp | 2. Shift position indicator | 3. Accelerator pedal position sensor |
| 4. CVT unit harness connector | 5. Fuel door release | 6. TCM |
| 7. Overdrive control switch | | |

TROUBLE DIAGNOSIS

< SERVICE INFORMATION >

Circuit Diagram

INFOID:000000001703455

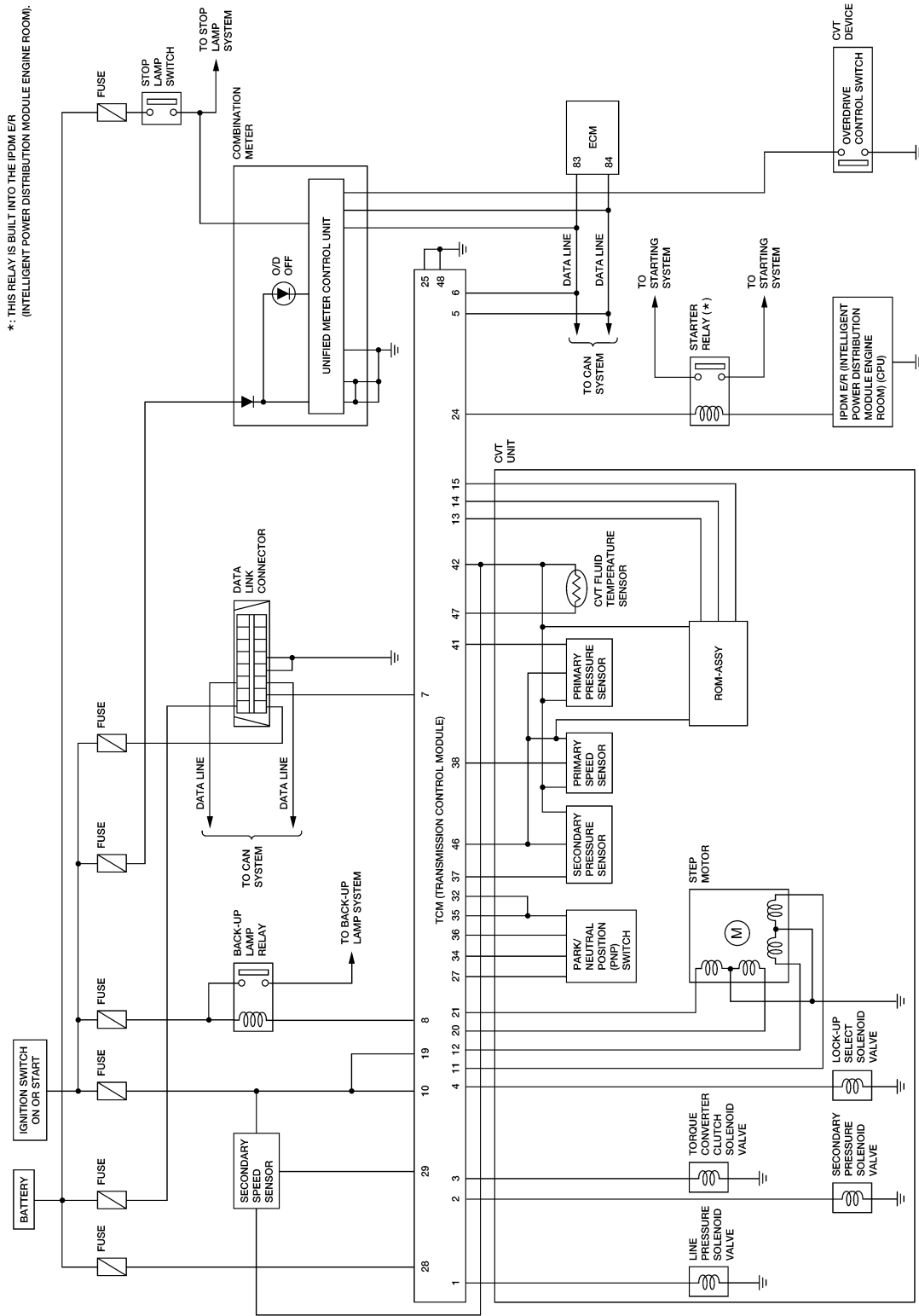

BCWA0667E

Inspections before Trouble Diagnosis

CVT FLUID CHECK

Fluid Leakage and Fluid Level Check

INFOID:000000001703456

TROUBLE DIAGNOSIS

< SERVICE INFORMATION >

- Inspect for fluid leakage and check the fluid level. Refer to [MA-19. "Checking CVT Fluid"](#).

Fluid Condition Check

Inspect the fluid condition.

Fluid status	Conceivable cause	Required operation
Varnished (viscous varnish state)	Clutch, brake scorched	Replace the CVT fluid and check the CVT main unit and the vehicle for malfunctions (wire harnesses, cooler pipes, etc.)
Milky white or cloudy	Water in the fluid	Replace the CVT fluid and check for places where water is getting in.
Large amount of metal powder mixed in	Unusual wear of sliding parts within CVT	Replace the CVT fluid and check for improper operation of the CVT.

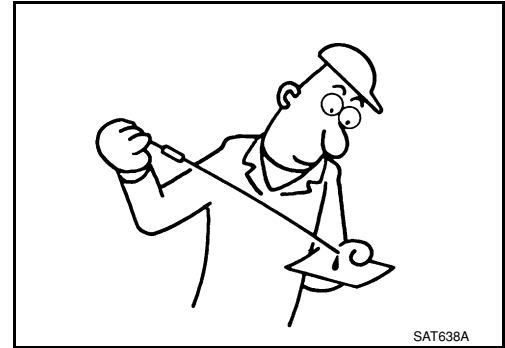

STALL TEST

Stall Test Procedure

1. Inspect the amount of engine oil. Replenish the engine oil if necessary.
2. Drive for about 10 minutes to warm up the vehicle so that the CVT fluid temperature is 50 to 80°C (122 to 176°F). Inspect the amount of CVT fluid. Replenish if necessary.

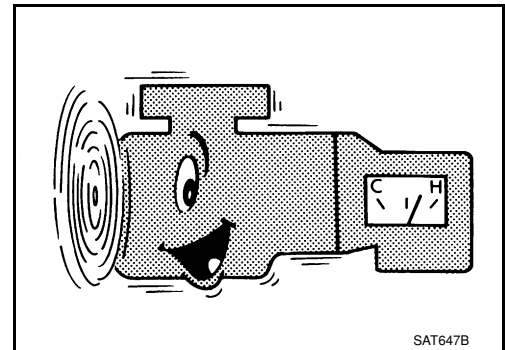

3. Securely engage the parking brake so that the tires do not turn.
4. Install a tachometer where it can be seen by driver during test.
 - **It is good practice to mark the point of specified engine rpm on indicator.**

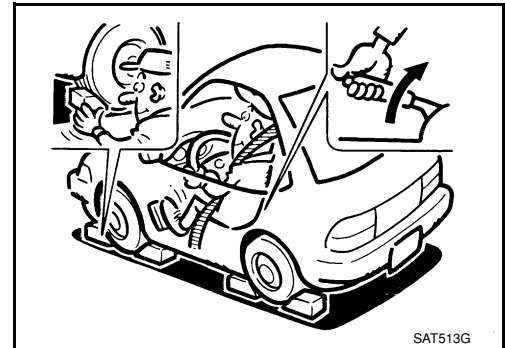

5. Start engine, apply foot brake, and place selector lever in "D" position.

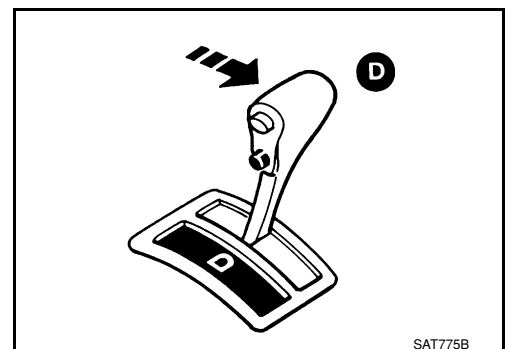

A
B
CVT
D
E
F
G
H
I
J
K
L
M
N
O
P

TROUBLE DIAGNOSIS

< SERVICE INFORMATION >

6. While holding down the foot brake, gradually press down the accelerator pedal.
7. Quickly read off the stall speed, and then quickly remove your foot from the accelerator pedal.

CAUTION:

Do not hold down the accelerator pedal for more than 5 seconds during this test.

Stall speed: 2,600 - 3,150 rpm

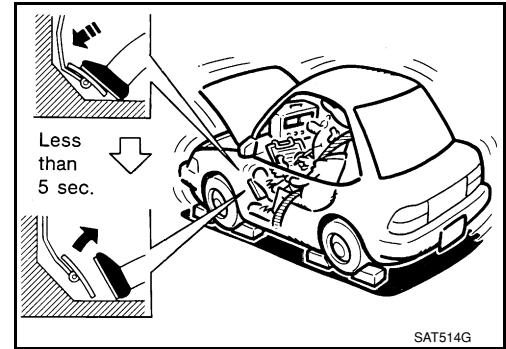

8. Move the selector lever to the "N" position.
9. Cool down the CVT fluid.
CAUTION:
Run the engine at idle for at least 1 minute.
10. Repeat steps 6 through 9 with selector lever in "R" position.

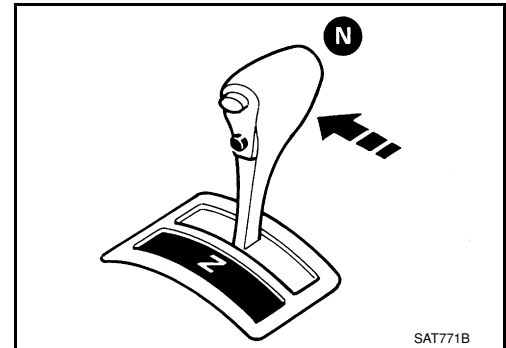

Judgement Stall Test

	Selector lever position		Expected problem location
	"D"	"R"	
Stall rotation	H	O	• Forward clutch
	O	H	• Reverse brake
	L	L	• Engine and torque converter one-way clutch
	H	H	• Line pressure low • Primary pulley • Secondary pulley • Steel belt

O: Stall speed within standard value position.

H: Stall speed is higher than standard value.

L: Stall speed is lower than standard value.

LINE PRESSURE TEST

Line Pressure Test Port

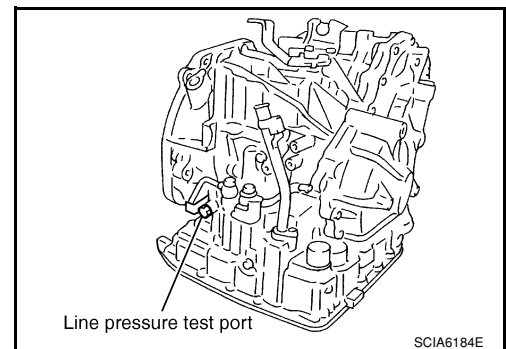

Line Pressure Test Procedure

1. Inspect the amount of engine oil and replenish if necessary.
2. Drive the car for about 10 minutes to warm it up so that the CVT fluid reaches in the range of 50 to 80°C (122 to 176°F), then inspect the amount of CVT fluid and replenish if necessary.

NOTE:

TROUBLE DIAGNOSIS

< SERVICE INFORMATION >

The CVT fluid temperature rises in the range of 50 - 80°C (122 - 176°F) during 10 minutes of driving.

- After warming up CVT, remove the oil pressure detection plug and install the oil pressure gauge [special service tool: - (OTC3492)].

CAUTION:

When using the oil pressure gauge, be sure to use the O-ring attached to the oil pressure detection plug.

- Securely engage the parking brake so that the tires do not turn.

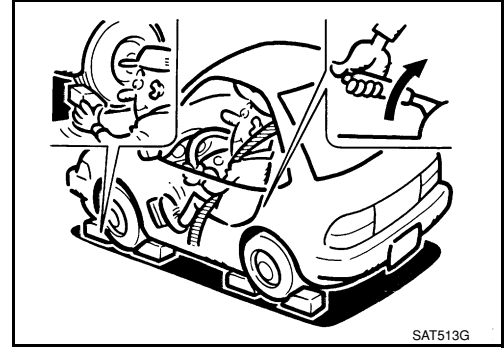

- Start the engine, and then measure the line pressure at both idle and the stall speed.

CAUTION:

- Keep the brake pedal pressed all the way down during measurement.
- When measuring the line pressure at the stall speed, refer to "STALL TEST" .

- After the measurements are complete, install the oil pressure detection plug and tighten to the specified torque below.

 : 7.5 N·m (0.77 kg-m, 66 in-lb)

CAUTION:

- Do not reuse O-ring.
- Apply CVT fluid to O-ring.

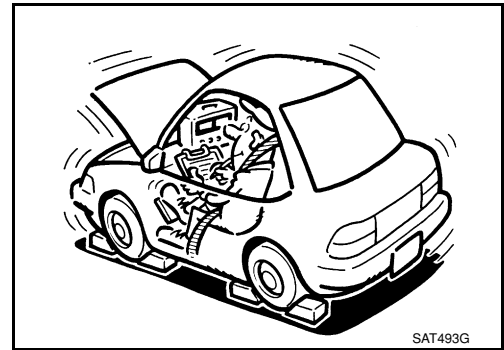

Line Pressure

Engine speed	Line pressure kPa (kg/cm ² , psi)
	"R", "D" and "L" positions
At idle	650 (6.63, 94.3)
At stall	4,250 (43.35, 616.3)*

*: Reference values

Judgement of Line Pressure Test

A
B
CVT
D
E
F
G
H
I
J
K
L
M
N
O
P

TROUBLE DIAGNOSIS

< SERVICE INFORMATION >

Judgement		Possible cause
Idle speed	Low for all positions ("P", "R", "N", "D", "L")	Possible causes include malfunctions in the pressure supply system and low oil pump output. For example <ul style="list-style-type: none"> • Oil pump wear • Pressure regulator valve or plug sticking or spring fatigue • Oil strainer ⇒ oil pump ⇒ pressure regulator valve passage oil leak • Engine idle speed too low
	Only low for a specific position	Possible causes include an oil pressure leak in a passage or device related to the position after the pressure is distributed by the manual valve.
	High	Possible causes include a sensor malfunction or malfunction in the line pressure adjustment function. For example <ul style="list-style-type: none"> • Accelerator pedal position signal malfunction • CVT fluid temperature sensor malfunction • Pressure control solenoid A (line pressure solenoid) malfunction (sticking in OFF state, filter clog, cut line) • Pressure regulator valve or plug sticking
Stall speed	Line pressure does not rise higher than the line pressure for idle.	Possible causes include a sensor malfunction or malfunction in the pressure adjustment function. For example <ul style="list-style-type: none"> • Accelerator pedal position signal malfunction • TCM malfunction • Pressure control solenoid A (line pressure solenoid) malfunction (shorting, sticking in ON state) • Pressure regulator valve or plug sticking
	The pressure rises, but does not enter the standard position.	Possible causes include malfunctions in the pressure supply system and malfunction in the pressure adjustment function. For example <ul style="list-style-type: none"> • Accelerator pedal position signal malfunction • Pressure control solenoid A (line pressure solenoid) malfunction (sticking, filter clog) • Pressure regulator valve or plug sticking
	Only low for a specific position	Possible causes include an oil pressure leak in a passage or device related to the position after the pressure is distributed by the manual valve.

Road Test

INFOID:000000001703457

DESCRIPTION

- The purpose of the test is to determine overall performance of CVT and analyze causes of problems.
- The road test consists of the following three parts:
 1. "Check Before Engine Is Started"[CVT-41](#) .
 2. "Check at Idle"[CVT-41](#) .
 3. "Cruise Test"[CVT-43](#) .

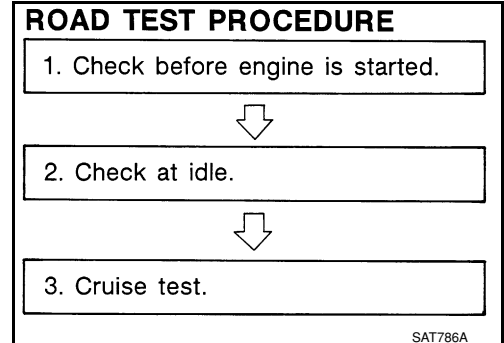

TROUBLE DIAGNOSIS

< SERVICE INFORMATION >

- Before road test, familiarize yourself with all test procedures and items to check.
- Perform tests on all items until specified symptom is found. Troubleshoot items which check out No Good after road test.

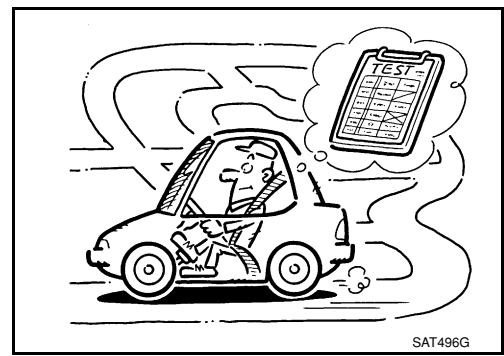

CONSULT-III START PROCEDURE

- Using CONSULT-III, perform a cruise test and record the result.
 - Print the result and ensure that shifts and lock-ups take place as per Shift Schedule.
1. Touch "DATA MONITOR" on "SELECT DIAG MODE" screen.
 2. Touch "MAIN SIGNALS" to set recording condition.
 3. See "Numerical Display", "Bar chart Display" or "Line Graph Display".
 4. Touch "START".
 5. When performing cruise test. Refer to [CVT-43, "Cruise Test"](#).
 6. After finishing cruise test part, touch "RECORD".
 7. Touch "STORE".
 8. Touch "BACK".
 9. Touch "DISPLAY".
 10. Touch "PRINT".
 11. Check the monitor data printed out.

Check before Engine Is Started

INFOID:000000001703458

1. CHECK O/D OFF INDICATOR LAMP

1. Park vehicle on flat surface.
2. Move selector lever to "P" position.
3. Turn ignition switch OFF. Wait at least 5 seconds.
4. Turn ignition switch ON. (Do not start engine.)

Does O/D OFF indicator lamp come on for about 2 seconds?

- YES >> 1. Turn ignition switch OFF.
2. Perform self-diagnosis and note NG items.
Refer to [CVT-47, "CONSULT-III Function \(TRANSMISSION\)"](#).
3. Go to [CVT-41, "Check at Idle"](#).
- NO >> Stop "Road Test". Go to [CVT-151, "O/D OFF Indicator Lamp Does Not Come On"](#).

Check at Idle

INFOID:000000001703459

1. CHECK STARTING THE ENGINE

1. Park vehicle on flat surface.
2. Move selector lever to "P" or "N" position.
3. Turn ignition switch OFF.
4. Turn ignition switch START.

Is engine started?

TROUBLE DIAGNOSIS

< SERVICE INFORMATION >

YES >> GO TO 2.

NO >> Stop "Road Test". Mark the box on the [CVT-30, "How to Perform Trouble Diagnosis for Quick and Accurate Repair"](#) . Go to [CVT-153, "Engine Cannot Be Started in "P" and "N" Position"](#) .

2.CHECK STARTING THE ENGINE

1. Turn ignition switch ON.
2. Move selector lever to "D", "L" or "R" position.
3. Turn ignition switch START.

Is engine started?

YES >> Stop "Road Test". Mark the box on the [CVT-30, "How to Perform Trouble Diagnosis for Quick and Accurate Repair"](#) . Go to [CVT-153, "Engine Cannot Be Started in "P" and "N" Position"](#) .

NO >> GO TO 3.

3.CHECK "P" POSITION FUNCTION

1. Move selector lever to "P" position.
2. Turn ignition switch OFF.
3. Release parking brake.
4. Push vehicle forward or backward.
5. Apply parking brake.

Does vehicle move when it is pushed forward or backward?

YES >> Mark the box [CVT-153, "In "P" Position, Vehicle Moves Forward or Backward When Pushed"](#) on the [CVT-30, "How to Perform Trouble Diagnosis for Quick and Accurate Repair"](#) . Continue "Road Test".

NO >> GO TO 4.

4.CHECK "N" POSITION FUNCTION

1. Start engine.
2. Move selector lever to "N" position.
3. Release parking brake.

Does vehicle move forward or backward?

YES >> Mark the box [CVT-154, "In "N" Position, Vehicle Moves"](#) on the [CVT-30, "How to Perform Trouble Diagnosis for Quick and Accurate Repair"](#) . Continue "Road Test".

NO >> GO TO 5.

5.CHECK SHIFT SHOCK

1. Apply foot brake.
2. Move selector lever to "R" position.

Is there large shock when changing from "N" to "R" position?

YES >> Mark the box [CVT-154, "Large Shock "N" → "R" Position"](#) on the [CVT-30, "How to Perform Trouble Diagnosis for Quick and Accurate Repair"](#) . Continue "Road Test".

NO >> GO TO 6.

6.CHECK "R" POSITION FUNCTION

Release foot brake for several seconds.

Does vehicle creep backward when foot brake is released?

YES >> GO TO 7.

NO >> Mark the box [CVT-155, "Vehicle Does Not Creep Backward in "R" Position"](#) on the [CVT-30, "How to Perform Trouble Diagnosis for Quick and Accurate Repair"](#) . Continue "Road Test".

7.CHECK "D", "L" POSITIONS FUNCTION

Move selector lever to "D" and "L" positions and check if vehicle creeps forward.

Does vehicle creep forward in all positions?

YES >> Go to [CVT-43, "Cruise Test"](#) .

NO >> Stop "Road Test". Mark the box on the [CVT-30, "How to Perform Trouble Diagnosis for Quick and Accurate Repair"](#) . Go to [CVT-156, "Vehicle Does Not Creep Forward in "D" or "L" Position"](#) .

TROUBLE DIAGNOSIS

< SERVICE INFORMATION >

Cruise Test

INFOID:000000001703460

1. CHECK VEHICLE SPEED WHEN SHIFTING GEARS — PART 1

1. Drive vehicle for approximately 10 minutes to warm engine oil and CVT fluid up to operating temperature.

CVT fluid operating temperature: 50 - 80°C (122 - 176°F)

2. Park vehicle on flat surface.
3. Move selector lever to "P" position.
4. Start engine.
5. Move selector lever to "L" position.
6. Accelerate vehicle to 2/8-way throttle depressing accelerator pedal constantly.

 **Read vehicle speed and engine speed. Refer to [CVT-45, "Vehicle Speed When Shifting Gears"](#).**

OK or NG

OK >> GO TO 2.

NG >> Mark the box of [CVT-157, "Vehicle Speed Does Not Change in "L" Position"](#) on the [CVT-30, "How to Perform Trouble Diagnosis for Quick and Accurate Repair"](#). Continue "Road Test".

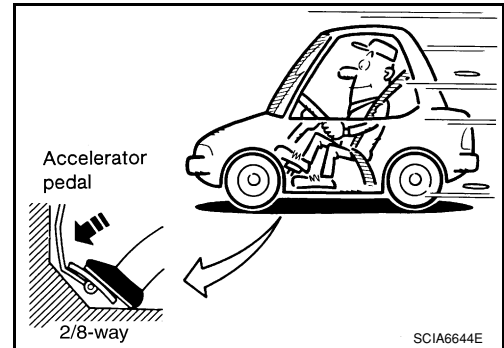

2. CHECK VEHICLE SPEED WHEN SHIFTING GEARS — PART 2

1. Park vehicle on flat surface.
2. Move selector lever to "D" position.
3. Push overdrive control switch. (O/D OFF indicator lamp is on.)
4. Accelerate vehicle to 2/8-way throttle depressing accelerator pedal constantly.

 **Read vehicle speed and engine speed. Refer to [CVT-45, "Vehicle Speed When Shifting Gears"](#).**

OK or NG

OK >> GO TO 3.

NG >> Mark the box of [CVT-158, "Vehicle Speed Does Not Change in overdrive-off mode"](#) on the [CVT-30, "How to Perform Trouble Diagnosis for Quick and Accurate Repair"](#). Continue "Road Test".

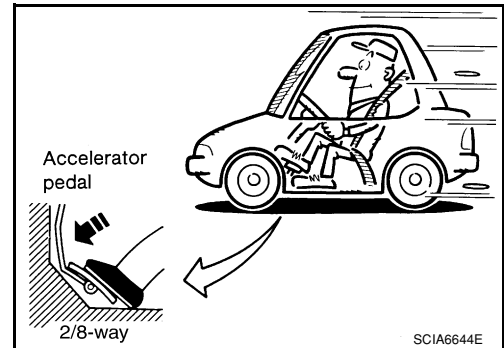

3. CHECK VEHICLE SPEED WHEN SHIFTING GEARS — PART 3

1. Park vehicle on flat surface.
2. Move selector lever to "D" position.
3. Push overdrive control switch. (O/D OFF indicator lamp is off.)
4. Accelerate vehicle to 2/8-way throttle depressing accelerator pedal constantly.

 **Read vehicle speed and engine speed. Refer to [CVT-45, "Vehicle Speed When Shifting Gears"](#).**

OK or NG

OK >> GO TO 4.

NG >> Mark the box of [CVT-159, "Vehicle Speed Does Not Change in "D" Position"](#) on the [CVT-30, "How to Perform Trouble Diagnosis for Quick and Accurate Repair"](#). Continue "Road Test".

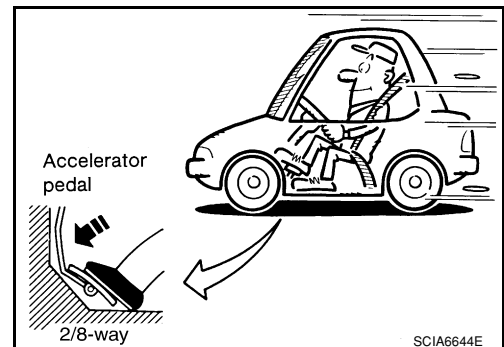

4. CHECK VEHICLE SPEED WHEN SHIFTING GEARS — PART 4

1. Park vehicle on flat surface.
2. Move selector lever to "L" position.

A
B
C
D
E
F
G
H
I
J
K
L
M
N
O
P

CVT

TROUBLE DIAGNOSIS

< SERVICE INFORMATION >

3. Accelerate vehicle to full depression depressing accelerator pedal constantly.

 **Read vehicle speed and engine speed. Refer to [CVT-45, "Vehicle Speed When Shifting Gears"](#).**

OK or NG

- OK >> GO TO 5.
NG >> Mark the box of [CVT-157, "Vehicle Speed Does Not Change in "L" Position"](#) on the [CVT-30, "How to Perform Trouble Diagnosis for Quick and Accurate Repair"](#). Continue "Road Test".

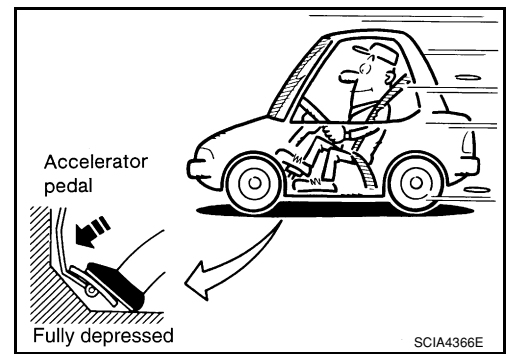

5. CHECK VEHICLE SPEED WHEN SHIFTING GEARS — PART 5

1. Park vehicle on flat surface.
2. Move selector lever to "D" position.
3. Push overdrive control switch. (O/D OFF indicator lamp is on.)
4. Accelerate vehicle to full depression depressing accelerator pedal constantly.

 **Read vehicle speed and engine speed. Refer to [CVT-45, "Vehicle Speed When Shifting Gears"](#).**

OK or NG

- OK >> GO TO 6.
NG >> Mark the box of [CVT-158, "Vehicle Speed Does Not Change in overdrive-off mode"](#) on the [CVT-30, "How to Perform Trouble Diagnosis for Quick and Accurate Repair"](#). Continue "Road Test".

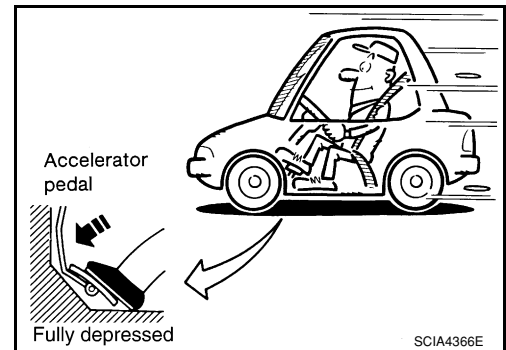

6. CHECK VEHICLE SPEED WHEN SHIFTING GEARS — PART 6

1. Park vehicle on flat surface.
2. Move selector lever to "D" position.
3. Push overdrive control switch. (O/D OFF indicator lamp is off.)
4. Accelerate vehicle to full depression depressing accelerator pedal constantly.

 **Read vehicle speed and engine speed. Refer to [CVT-45, "Vehicle Speed When Shifting Gears"](#).**

OK or NG

- OK >> GO TO 7.
NG >> Mark the box of [CVT-159, "Vehicle Speed Does Not Change in "D" Position"](#) on the [CVT-30, "How to Perform Trouble Diagnosis for Quick and Accurate Repair"](#). Continue "Road Test".

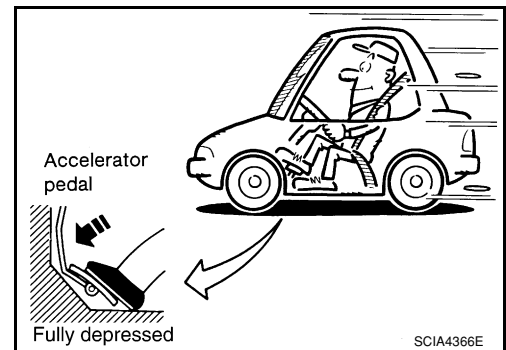

7. CHECK ENGINE BRAKE FUNCTION — PART 1

1. Release accelerator pedal.
2. Check engine brake. (O/D OFF indicator lamp is off.)

Does engine braking effectively reduce speed in "D" position?

- YES >> GO TO 8.
NO >> Mark the box of [CVT-159, "Vehicle Does Not Decelerate by Engine Brake"](#) on the [CVT-30, "How to Perform Trouble Diagnosis for Quick and Accurate Repair"](#). Continue "Road Test".

8. CHECK ENGINE BRAKE FUNCTION — PART 2

1. Push overdrive control switch. (O/D OFF indicator lamp is on.)
2. Check engine brake.

Does engine braking effectively reduce speed in "D" position?

- YES >> GO TO 9.
NO >> Mark the box of [CVT-159, "Vehicle Does Not Decelerate by Engine Brake"](#) on the [CVT-30, "How to Perform Trouble Diagnosis for Quick and Accurate Repair"](#). Continue "Road Test".

TROUBLE DIAGNOSIS

< SERVICE INFORMATION >

9. CHECK ENGINE BRAKE FUNCTION — PART 3

1. Move selector lever to "L" position.
2. Check engine brake.

Does engine braking effectively reduce speed in "L" position?

- YES >> 1. Stop the vehicle.
2. Perform self-diagnosis. Refer to [CVT-47, "CONSULT-III Function \(TRANSMISSION\)"](#).
- NO >> Mark the box of [CVT-159, "Vehicle Does Not Decelerate by Engine Brake"](#) on the [CVT-30, "How to Perform Trouble Diagnosis for Quick and Accurate Repair"](#). Then continue trouble diagnosis.

Vehicle Speed When Shifting Gears

INFOID:000000001703461

Numerical value data are reference values.

Engine type	Throttle position	Shift pattern	Engine speed (rpm)	
			At 40 km/h (25 MPH)	At 60 km/h (37 MPH)
MR18DE	8/8	"D" position	3,600 - 4,500	4,400 - 5,300
		Overdrive-off mode "L" position		
	2/8	"D" position	1,300 - 3,100	1,400 - 3,500
		Overdrive-off mode	2,200 - 3,000	2,800 - 3,600
		"L" position	3,200 - 4,100	3,900 - 4,800

CAUTION:

Lock-up clutch is engaged when vehicle speed is approximately 18 km/h (11 MPH) to 90 km/h (56 MPH).

TCM Terminal and Reference Value

INFOID:000000001703462

TCM HARNESS CONNECTOR TERMINAL LAYOUT

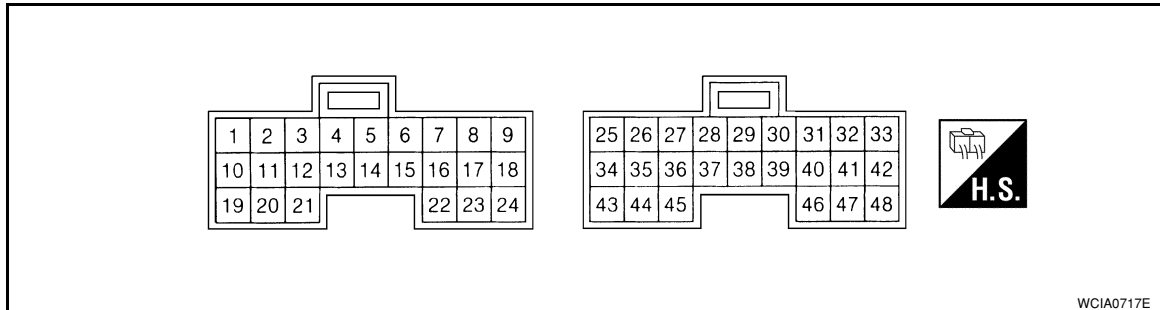









TERMINALS AND REFERENCE VALUES FOR TCM

Data are reference values and are measured between each terminal and ground.

Terminal	Wire color	Item	Condition		Data (Approx.)
1	GR	Pressure control solenoid valve A (Line pressure solenoid valve)		Release your foot from the accelerator pedal.	5.0 - 7.0 V
				Press the accelerator pedal all the way down.	1.0 - 3.0 V
2	LG	Pressure control solenoid valve B (Secondary pressure solenoid valve)	 	Release your foot from the accelerator pedal.	5.0 - 7.0 V
				Press the accelerator pedal all the way down.	3.0 - 4.0 V
3	SB	Torque converter clutch solenoid valve		When vehicle cruises in "D" position.	When CVT performs lock-up. 6.0 V
					When CVT does not perform lock-up. 1.0 V







TROUBLE DIAGNOSIS

< SERVICE INFORMATION >

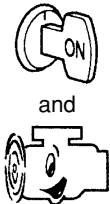
Terminal	Wire color	Item	Condition		Data (Approx.)
4	BR	Lock-up select solenoid valve		Selector lever in "P" and "N" positions	Battery voltage
				Wait at least for 5 seconds with the selector lever in "R", "D" and "L" positions	0 V
5	L	CAN-H	—		—
6	P	CAN-L	—		—
8	V	Back-up lamp relay		Selector lever in "R" position.	0 V
				Selector lever in other positions.	Battery voltage
10	R	Power supply		—	Battery voltage
					—
11	L	Step motor A	Within 2 seconds after ignition switch ON, the time measurement by using the pulse width measurement function (Hi level) of CONSULT-III.*1 *1: A circuit tester cannot be used to test this item.		30.0 msec
12	Y	Step motor B			10.0 msec
13	G	ROM assembly	—		—
14	Y	ROM assembly	—		—
15	G	ROM assembly	—		—
19	R	Power supply		—	Battery voltage
					—
20	W	Step motor C	Within 2 seconds after ignition switch ON, the time measurement by using the pulse width measurement function (Hi level) of CONSULT-III.*1 *1: A circuit tester cannot be used to test this item.		30.0 msec
21	P	Step motor D			10.0 msec
24	BR	Starter relay		Selector lever in "N" and "P" positions.	Battery voltage
				Selector lever in other positions.	0 V
25	B	Ground	Always		0 V
27	GR	PNP switch 1		Selector lever in "R", "N" and "D" positions.	0 V
				Selector lever in "P" and "L" positions.	Battery voltage
28	Y	Power supply (memory back-up)	Always		Battery voltage
29	R	Output speed sensor (Secondary speed sensor)		When driving ["D" position, 20 km/h (12 MPH)].	570 Hz
31	LG	K-LINE	—		—

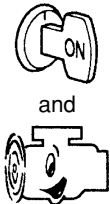
TROUBLE DIAGNOSIS

< SERVICE INFORMATION >

Terminal	Wire color	Item	Condition		Data (Approx.)	
32	Y	PNP switch 3 (monitor)		Selector lever in "D" and "L" positions.	0 V	A
				Selector lever in "P", "R" and "N" positions.	8.0 V - Battery voltage	B
34	SB	PNP switch 2		Selector lever in "N", "D" and "L" positions.	0 V	CVT
				Selector lever in "P" and "R" positions.	10.0 V - Battery voltage	
35	W	PNP switch 3		Selector lever in "D" and "L" positions.	0 V	D
				Selector lever in "P", "R" and "N" positions.	8.0 V - Battery voltage	
36	W	PNP switch 4	Selector lever in "R" and "D" positions.	0 V	E	
			Selector lever in "P", "N" and "L" positions.	10.0 V - Battery voltage		
37	L	Transmission fluid pressure sensor A (Secondary pressure sensor)		"N" position idle	1.0 V	F
38	V	Input speed sensor (Primary speed sensor)		When driving ["L" position, 20 km/h (12 MPH)].	1000 Hz	H
41	G	Transmission fluid pressure sensor B (Primary pressure sensor)		"N" position idle	0.7 V	I
42	LG	Sensor ground	Always		0 V	K
46	O	Sensor power		—	5.0 V	L
				—	0 V	M
47	G	CVT fluid temperature sensor		When CVT fluid temperature is 20°C (68°F)	2.0 V	N
				When CVT fluid temperature is 80°C (176°F)	1.0 V	
48	B	Ground	Always		0 V	

CONSULT-III Function (TRANSMISSION)

INFOID:000000001703463

CONSULT-III can display each diagnostic item using the diagnostic test modes shown below.

FUNCTION

Diagnostic test mode	Function
Work support	This mode enables a technician to adjust some devices faster and more accurately by following the indications on CONSULT-III.
Self-diagnostic results	Self-diagnostic results can be read and erased quickly.
Data monitor	Input/Output data in the TCM can be read.

TROUBLE DIAGNOSIS

< SERVICE INFORMATION >

Diagnostic test mode	Function
CAN diagnostic support monitor	The results of transmit/receive diagnosis of CAN communication can be read.
CALIB data	Characteristic information for TCM and CVT assembly can be read.
Function test	Performed by CONSULT-III instead of a technician to determine whether each system is "OK" or "NG".
ECU part number	TCM part number can be read.

CONSULT-III REFERENCE VALUE

Item name	Condition	Display value (Approx.)
VSP SENSOR	During driving	Approximately matches the speedometer reading.
ESTM VSP SIG*		
PRI SPEED SEN	During driving (lock-up ON)	Approximately matches the engine speed.
ENG SPEED SIG	Engine running	Closely matches the tachometer reading.
SEC HYDR SEN	"N" position idle	1.0 V
PRI HYDR SEN	"N" position idle	0.7 V
ATF TEMP SEN	When CVT fluid temperature is 20°C (68°F).	2.0 V
	When CVT fluid temperature is 80°C (176°F).	1.0 V
VIGN SEN	Ignition switch: ON	Battery voltage
VEHICLE SPEED	During driving	Approximately matches the speedometer reading.
PRI SPEED	During driving (lock-up ON)	Approximately matches the engine speed.
SEC SPEED	During driving	50 X Approximately matches the speedometer reading.
ENG SPEED	Engine running	Closely matches the tachometer reading.
GEAR RATIO	During driving	2.56 - 0.43
ACC PEDAL OPEN	Released accelerator pedal - Fully depressed accelerator pedal	0.0/8 - 8.0/8
SEC PRESS	"N" position idle	0.8 MPa
PRI PRESS	"N" position idle	0.4 MPa
STM STEP	During driving	-20 step - 180 step
ISOLT1	Lock-up OFF	0.0 A
	Lock-up ON	0.7 A
ISOLT2	Release your foot from the accelerator pedal.	0.8 A
	Press the accelerator pedal all the way down.	0.0 A
ISOLT3	Secondary pressure low - Secondary pressure high.	0.8 - 0.0 A
SOLMON1	Lock-up OFF	0.0 A
	Lock-up ON	0.7 A
SOLMON2	"N" position idle	0.8 A
	When stalled	0.3 - 0.6 A
SOLMON3	"N" position idle	0.6 - 0.7 A
	When stalled	0.4 - 0.6 A
INH SW3M	Selector lever in "D" and "L" positions	ON
	Selector lever in "P", "R" and "N" positions	OFF
INH SW4	Selector lever in "R" and "D" positions	ON
	Selector lever in "P", "N" and "L" positions	OFF

TROUBLE DIAGNOSIS

< SERVICE INFORMATION >

Item name	Condition	Display value (Approx.)	
INH SW3	Selector lever in "D" and "L" positions	ON	A
	Selector lever in "P", "R" and "N" positions	OFF	
INH SW2	Selector lever in "N", "D" and "L" positions	ON	B
	Selector lever in "P" and "R" positions	OFF	
INH SW1	Selector lever in "R", "N" and "D" positions	ON	CVT
	Selector lever in "P" and "L" positions	OFF	
BRAKE SW	Depressed brake pedal	ON	
	Released brake pedal	OFF	D
FULL SW	Fully depressed accelerator pedal	ON	
	Released accelerator pedal	OFF	E
IDLE SW	Released accelerator pedal	ON	
	Fully depressed accelerator pedal	OFF	F
SPORT MODE SW	While pushing overdrive cancel switch	ON	
	Other conditions	OFF	G
INDDRNG	Selector lever in "D" position	ON	
	Selector lever in other positions	OFF	H
INDLRNG	Selector lever in "L" position	ON	
	Selector lever in other positions	OFF	I
INDNRNG	Selector lever in "N" position	ON	
	Selector lever in other positions	OFF	J
INDRRNG	Selector lever in "R" position	ON	
	Selector lever in other positions	OFF	K
INDPRNG	Selector lever in "P" position	ON	
	Selector lever in other positions	OFF	L
SMCOIL D	During driving	Changes ON ⇔ OFF.	
SMCOIL C			
SMCOIL B			
SMCOIL A			
LUSEL SOL OUT	Selector lever in "P" and "N" positions	ON	
	Wait at least for 5 seconds with the selector lever in "R", "D" and "L" positions	OFF	M
STRTR RLY OUT	Selector lever in "P" and "N" positions	ON	
	Selector lever in other positions	OFF	N
STRTR RLY MON	Selector lever in "P" and "N" positions	ON	
	Selector lever in other positions	OFF	O
RANGE	Selector lever in "N" or "P" position.	N·P	
	Selector lever in "R" position.	R	
	Selector lever in "D" position.	D	
	Selector lever in "L" position.	L	P

*: Models without ABS does not indicate.

WORK SUPPORT MODE

Display Item List

TROUBLE DIAGNOSIS

< SERVICE INFORMATION >

Item name	Description
ENGINE BRAKE ADJ.	The engine brake level setting can be canceled.
CONFORM CVTF DETERIORATION	The CVT fluid deterioration level can be checked.

Engine Brake Adjustment

“ENGINE BRAKE LEVEL”

0: Initial set value (Engine brake level control is activated)

OFF: Engine brake level control is deactivated.

CAUTION:

Mode of “+1” “0” “-1” “-2” “OFF” can be selected by pressing the “UP” “DOWN” on CONSULT-III screen. However, do not select mode other than “0” and “OFF”. If the “+1” or “-1” or “-2” is selected, that might cause the irregular driveability.

Check CVT Fluid Deterioration Date

“CVTF DETERIORATION DATE”

More than 210000:

It is necessary to change CVT fluid.

Less than 210000:

It is not necessary to change CVT fluid.

CAUTION:

Touch “CLEAR” after changing CVT fluid, and then erase “CVTF DETERIORATION DATE”.

SELF-DIAGNOSTIC RESULT MODE

After performing self-diagnosis, place check marks for results on the [CVT-30, "How to Perform Trouble Diagnosis for Quick and Accurate Repair"](#). Reference pages are provided following the items.

Display Items List

X: Applicable —: Not applicable

Items (CONSULT-III screen terms)	Malfunction is detected when...	TCM self-diagnosis	OBD-III (DTC)	Reference page
		“TRANSMISSION” with CONSULT-III	MIL indicator lamp*1, “ENGINE” with CONSULT-III or GST	
CAN COMM CIRCUIT	When TCM is not transmitting or receiving CAN communication signal for 2 seconds or more	U1000	U1000	CVT-56
CONTROL UNIT(CAN)	When detecting error during the initial diagnosis of CAN controller of TCM	U1010	U1010	CVT-59
STARTER RELAY/CIRC	If this signal is ON other than in “P” or “N” position, this is judged to be a malfunction (And if it is OFF in “P” or “N” position, this is judged to be a malfunction too)	P0615	—	CVT-60
BRAKE SW/CIRC	When the brake switch does not switch to ON or OFF	P0703	—	CVT-63
PNP SW/CIRC	<ul style="list-style-type: none"> PNP switch 1-4 signals input with impossible pattern PNP switch 3 monitor terminal open or short circuit 	P0705	P0705	CVT-65
ATF TEMP SEN/CIRC	During running, the CVT fluid temperature sensor signal voltage is excessively high or low	P0710	P0710	CVT-71
INPUT SPD SEN/CIRC	<ul style="list-style-type: none"> Input speed sensor (primary speed sensor) signal is not input due to an open circuit An unexpected signal is input when vehicle is being driven 	P0715	P0715	CVT-76

TROUBLE DIAGNOSIS

< SERVICE INFORMATION >

Items (CONSULT-III screen terms)	Malfunction is detected when...	TCM self-diagnosis	OBD-III (DTC)	Reference page	
		"TRANSMISSION" with CONSULT-III	MIL indicator lamp*1, "ENGINE" with CONSULT-III or GST		
VEH SPD SEN/CIR AT	<ul style="list-style-type: none"> Signal from vehicle speed sensor CVT [Output speed sensor (Secondary speed sensor)] not input due to open or short circuit Unexpected signal input during running 	P0720	P0720	CVT-80	CVT
ENGINE SPEED SIG	<ul style="list-style-type: none"> TCM does not receive the CAN communication signal from the ECM Engine speed is too low while driving 	P0725	—	CVT-85	D
BELT DAMG	Unexpected gear ratio detected	P0730	—	CVT-87	E
TCC SOLENOID/CIRC	Normal voltage not applied to solenoid due to open or short circuit	P0740	P0740	CVT-88	
A/T TCC S/V FNCTN	<ul style="list-style-type: none"> CVT cannot perform lock-up even if electrical circuit is good TCM detects as irregular by comparing difference value with slip rotation There is big difference engine speed and primary speed when TCM lock-up signal is on 	P0744	P0744	CVT-93	F
L/PRESS SOL/CIRC	<ul style="list-style-type: none"> Normal voltage not applied to solenoid due to open or short circuit TCM detects as irregular by comparing target value with monitor value 	P0745	P0745	CVT-95	G
PRS CNT SOL/A FCTN	Unexpected gear ratio was detected in the LOW side due to excessively low line pressure	P0746	P0746	CVT-100	H
PRS CNT SOL/B FCTN	Secondary pressure is too high or too low compared with the commanded value while driving	P0776	P0776	CVT-102	I
PRS CNT SOL/B CIRC	<ul style="list-style-type: none"> Normal voltage not applied to solenoid due to cut line, short, or the like TCM detects as irregular by comparing target value with monitor value 	P0778	P0778	CVT-104	J
TR PRS SENS/A CIRC	Signal voltage of the transmission fluid pressure sensor A (secondary pressure sensor) is too high or too low while driving	P0840	P0840	CVT-109	K
PRESS SEN/FNCTN	Correlation between the values of the transmission fluid pressure sensor A (secondary pressure sensor) and the transmission fluid pressure sensor B (primary pressure sensor) is out of specification	P0841	—	CVT-113	L
TR PRS SENS/B CIRC	Signal voltage of the transmission fluid pressure sensor B (primary pressure sensor) is too high or too low while driving	P0845	P0845	CVT-115	M
SEC/PRESS DOWN	Secondary fluid pressure is too low compared with the commanded value while driving	P0868	—	CVT-119	N
TCM-POWER SUPPLY	<ul style="list-style-type: none"> When the power supply to the TCM is cut OFF, for example because the battery is removed, and the self-diagnosis memory function stops This is not a malfunction message (Whenever shutting OFF a power supply to the TCM, this message appears on the screen) 	P1701	—	CVT-121	O
TP SEN/CIRC A/T	TCM does not receive the proper accelerator pedal position signals (input by CAN communication) from ECM	P1705	—	CVT-125	P
ESTM VEH SPD SIG*2	<ul style="list-style-type: none"> CAN communication with the ABS actuator and the electric unit (control unit) is malfunctioning There is a great difference between the vehicle speed signal from the ABS actuator and the electric unit (control unit), and the vehicle speed sensor signal 	P1722	—	CVT-127	

TROUBLE DIAGNOSIS

< SERVICE INFORMATION >

Items (CONSULT-III screen terms)	Malfunction is detected when...	TCM self-diagnosis	OBD-III (DTC)	Reference page
		"TRANSMISSION" with CONSULT-III	MIL indicator lamp*1, "ENGINE" with CONSULT-III or GST	
CVT SPD SEN/FUNCTN	A rotation sensor error is detected because the gear does not change in accordance with the position of the stepping motor CAUTION: One of the "P0720 VEH SPD SEN/CIR AT", the "P0715 INPUT SPD SEN/CIRC" or the "P0725 ENGINE SPEED SIG" is displayed with the DTC at the same time	P1723	—	CVT-129
ELEC TH CONTROL	The electronically controlled throttle for ECM is malfunctioning	P1726	—	CVT-131
LU-SLCT SOL/CIRC	<ul style="list-style-type: none"> Normal voltage not applied to solenoid due to cut line, short, or the like TCM detects as irregular by comparing target value with monitor value 	P1740	P1740	CVT-132
L/PRESS CONTROL	TCM detects the unexpected line pressure	P1745	—	CVT-136
STEP MOTR CIRC	Each coil of the step motor is not energized properly due to an open or a short	P1777	P1777	CVT-137
STEP MOTR/FNC	There is a great difference between the number of steps for the stepping motor and for the actual gear ratio	P1778	P1778	CVT-141
NO DTC IS DETECTED: FURTHER TESTING MAY BE REQUIRED	No NG item has been detected	X	X	—

*1: Refer to [CVT-27, "Malfunction Indicator Lamp \(MIL\)"](#) .

*2: Models without ABS does not indicate.

DATA MONITOR MODE

Display Items List

X: Standard, —: Not applicable, ▼: Option

Monitored item (Unit)	Monitor item selection			Remarks
	ECU INPUT SIGNALS	MAIN SIGNALS	SELECTION FROM MENU	
VSP SENSOR (km/h)	X	—	▼	Output speed sensor (secondary speed sensor).
ESTM VSP SIG (km/h)	X	—	▼	Models without ABS does not indicate.
PRI SPEED SEN (rpm)	X	—	▼	
ENG SPEED SIG (rpm)	X	—	▼	
SEC HYDR SEN (V)	X	—	▼	
PRI HYDR SEN (V)	X	—	▼	
ATF TEMP SEN (V)	X	—	▼	CVT fluid temperature sensor
VIGN SEN (V)	X	—	▼	
VEHICLE SPEED (km/h)	—	X	▼	Vehicle speed recognized by the TCM.
PRI SPEED (rpm)	—	X	▼	Primary pulley speed.
SEC SPEED (rpm)	—	—	▼	Secondary pulley speed.

TROUBLE DIAGNOSIS

< SERVICE INFORMATION >

Monitored item (Unit)	Monitor item selection			Remarks
	ECU INPUT SIGNALS	MAIN SIGNALS	SELECTION FROM MENU	
ENG SPEED (rpm)	—	X	▼	
SLIP REV (rpm)	—	X	▼	Difference between engine speed and primary pulley speed
GEAR RATIO	—	X	▼	
G SPEED (G)	—	—	▼	
ACC PEDAL OPEN (0.0/8)	X	X	▼	Degree of opening for accelerator recognized by the TCM For fail-safe operation, the specific value used for control is displayed.
TRQ RTO	—	—	▼	
SEC PRESS (MPa)	—	X	▼	
PRI PRESS (MPa)	—	X	▼	
ATFTEMP COUNT	—	X	▼	Means CVT fluid temperature. Actual oil temperature (°C) cannot be checked unless a numeric value is converted. Refer to CVT-8 .
DSR REV (rpm)	—	—	▼	
DGEAR RATIO	—	—	▼	
DSTM STEP (step)	—	—	▼	
STM STEP (step)	—	X	▼	
LU PRS (MPa)	—	—	▼	
LINE PRS (MPa)	—	—	▼	
TGT SEC PRESS (MPa)	—	—	▼	
ISOLT1 (A)	—	X	▼	Torque converter clutch solenoid valve output current
ISOLT2 (A)	—	X	▼	Pressure control solenoid valve A (line pressure solenoid valve) output current
ISOLT3 (A)	—	X	▼	Pressure control solenoid valve B (secondary pressure solenoid valve) output current
SOLMON1 (A)	X	X	▼	Torque converter clutch solenoid valve monitor current
SOLMON2 (A)	X	X	▼	Pressure control solenoid valve A (line pressure solenoid valve) monitor current
SOLMON3 (A)	X	X	▼	Pressure control solenoid valve B (secondary pressure solenoid valve) monitor current
INH SW3M (ON/OFF)	X	—	▼	PNP switch 3 ON-OFF status monitor
INH SW4 (ON/OFF)	X	—	▼	PNP switch 4 ON-OFF status
INH SW3 (ON/OFF)	X	—	▼	PNP switch 3 ON-OFF status
INH SW2 (ON/OFF)	X	—	▼	PNP switch 2 ON-OFF status
INH SW1 (ON/OFF)	X	—	▼	PNP switch 1 ON-OFF status
BRAKE SW (ON/OFF)	X	X	▼	Stop lamp switch (Signal input with CAN communication)

A

B

CVT

D

E

F

G

H

I

J

K

L

M

N

O

P

TROUBLE DIAGNOSIS

< SERVICE INFORMATION >

Monitored item (Unit)	Monitor item selection			Remarks
	ECU INPUT SIGNALS	MAIN SIGNALS	SELECTION FROM MENU	
FULL SW (ON/OFF)	X	X	▼	Signal input with CAN communications
IDLE SW (ON/OFF)	X	X	▼	
SPORT MODE SW (ON/OFF)	X	X	▼	Overdrive control switch (Signal input with CAN communication)
STRDWNSW (ON/OFF)	X	—	▼	Not mounted but displayed.
STRUPSW (ON/OFF)	X	—	▼	
DOWNLVR (ON/OFF)	X	—	▼	
UPLVR (ON/OFF)	X	—	▼	
NONMMODE (ON/OFF)	X	—	▼	
MMODE (ON/OFF)	X	—	▼	
INDLRNG (ON/OFF)	—	—	▼	
INDDRNG (ON/OFF)	—	—	▼	"D" position indicator output
INDNRNG (ON/OFF)	—	—	▼	"N" position indicator output
INDRRNG (ON/OFF)	—	—	▼	"R" position indicator output
INDPRNG (ON/OFF)	—	—	▼	"P" position indicator output
CVT LAMP (ON/OFF)	—	—	▼	
SPORT MODE IND (ON/OFF)	—	—	▼	
MMODE IND (ON/OFF)	—	—	▼	Not mounted but displayed.
SMCOIL D (ON/OFF)	—	—	▼	Step motor coil "D" energizing status
SMCOIL C (ON/OFF)	—	—	▼	Step motor coil "C" energizing status
SMCOIL B (ON/OFF)	—	—	▼	Step motor coil "B" energizing status
SMCOIL A (ON/OFF)	—	—	▼	Step motor coil "A" energizing status
LUSEL SOL OUT (ON/OFF)	—	—	▼	
REV LAMP (ON/OFF)	—	X	▼	
STRTR RLY OUT (ON/OFF)	—	—	▼	Starter relay
LUSEL SOL MON (ON/OFF)	—	—	▼	
STRTR RLY MON (ON/OFF)	—	—	▼	Starter relay
VDC ON (ON/OFF)	X	—	▼	Not mounted but displayed.
TCS ON (ON/OFF)	X	—	▼	
ABS ON (ON/OFF)	X	—	▼	
ACC ON (ON/OFF)	X	—	▼	Not mounted but displayed.
RANGE	—	X	▼	Indicates position is recognized by TCM. Indicates a specific value required for control when fail-safe function is activated.
M GEAR POS	—	X	▼	
Voltage (V)	—	—	▼	Displays the value measured by the voltage probe.

TROUBLE DIAGNOSIS

< SERVICE INFORMATION >

Monitored item (Unit)	Monitor item selection			Remarks
	ECU INPUT SIGNALS	MAIN SIGNALS	SELECTION FROM MENU	
Frequency (Hz)	—	—	▼	The value measured by the pulse probe is displayed.
DUTY-HI (high) (%)	—	—	▼	
DUTY-LOW (low) (%)	—	—	▼	
PLS WIDTH-HI (ms)	—	—	▼	
PLS WIDTH-LOW (ms)	—	—	▼	

Diagnosis Procedure without CONSULT-III

INFOID:000000001703464

OBD-II SELF-DIAGNOSTIC PROCEDURE (WITH GST)

Refer to [EC-119. "Generic Scan Tool \(GST\) Function"](#).

A
B
CVT
D
E
F
G
H
I
J
K
L
M
N
O
P

DTC U1000 CAN COMMUNICATION LINE

< SERVICE INFORMATION >

DTC U1000 CAN COMMUNICATION LINE

Description

INFOID:000000001703465

CAN (Controller Area Network) is a serial communication line for real time application. It is an on-vehicle multiplex communication line with high data communication speed and excellent malfunction detection ability. Many electronic control units are equipped onto a vehicle, and each control unit shares information and links with other control units during operation (not independent). In CAN communication, control units are connected with 2 communication lines (CAN-H line, CAN-L line) allowing a high rate of information transmission with less wiring. Each control unit transmits/receives data but selectively reads required data only.

On Board Diagnosis Logic

INFOID:000000001703466

- This is an OBD-II self-diagnostic item.
- Diagnostic trouble code "U1000 CAN COMM CIRCUIT" with CONSULT-III is detected when TCM cannot communicate to other control units.

Possible Cause

INFOID:000000001703467

Harness or connectors
(CAN communication line is open or shorted.)

DTC Confirmation Procedure

INFOID:000000001703468

NOTE:

If "DTC Confirmation Procedure" has been previously performed, always turn ignition switch OFF and wait at least 10 seconds before performing the next test.

After the repair, touch "ERASE" on "SELF-DIAG RESULTS" and then perform the following procedure to confirm the malfunction is eliminated.

Ⓜ WITH CONSULT-III

1. Turn ignition switch ON. (Do not start engine.)
2. Select "DATA MONITOR" mode for "TRANSMISSION" with CONSULT-III.
3. Start engine and wait for at least 6 seconds.
4. If DTC is detected, go to [CVT-58. "Diagnosis Procedure"](#).

Ⓜ WITH GST

Follow the procedure "WITH CONSULT-III".



DTC U1000 CAN COMMUNICATION LINE

< SERVICE INFORMATION >

Wiring Diagram - CVT - CAN

INFOID:000000001703469

CVT-CAN-01

-  : DETECTABLE LINE FOR DTC
-  : NON-DETECTABLE LINE FOR DTC
-  : DATA LINE

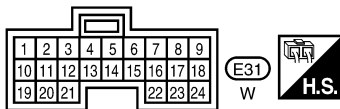
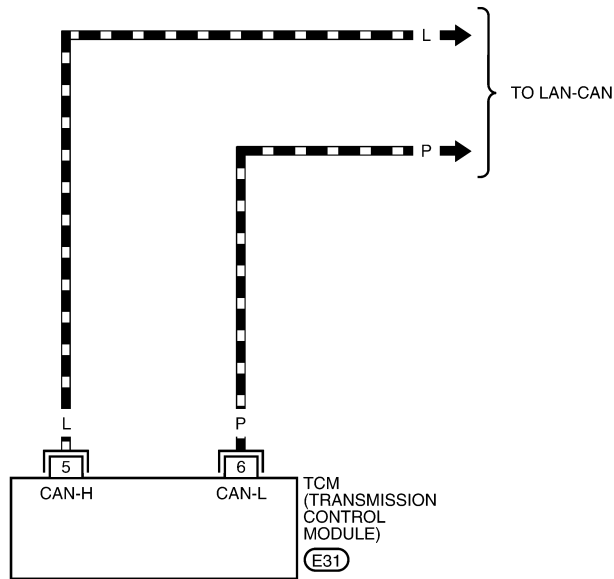

TCM TERMINALS AND REFERENCE VALUES
Refer to [CVT-45, "TCM Terminal and Reference Value"](#).

BCWA0668E

DTC U1000 CAN COMMUNICATION LINE

< SERVICE INFORMATION >

Diagnosis Procedure

INFOID:000000001703470

1. CHECK CAN COMMUNICATION CIRCUIT

Ⓟ **With CONSULT-III**

1. Turn ignition switch ON and start engine.
2. Select "SELF-DIAG RESULTS" mode for "TRANSMISSION" with CONSULT-III.

Is any malfunction of the "U1000 CAN COMM CIRCUIT" indicated?

YES >> Print out CONSULT-III screen, go to LAN section. Refer to [LAN-23. "CAN System Specification Chart"](#).

NO >> **INSPECTION END**

DTC U1010 TRANSMISSION CONTROL MODULE (CAN)

< SERVICE INFORMATION >

DTC U1010 TRANSMISSION CONTROL MODULE (CAN)

Description

INFOID:000000001703471

CAN (Controller Area Network) is a serial communication line for real time application. It is an on-vehicle multiplex communication line with high data communication speed and excellent malfunction detection ability. Many electronic control units are equipped onto a vehicle, and each control unit shares information and links with other control units during operation (not independent). In CAN communication, control units are connected with 2 communication lines (CAN-H line, CAN-L line) allowing a high rate of information transmission with less wiring. Each control unit transmits/receives data but selectively reads required data only.

On Board Diagnosis Logic

INFOID:000000001703472

- This is an OBD-II self-diagnostic item.
- Diagnostic trouble code "U1010 CONTROL UNIT(CAN)" with CONSULT-III is detected when TCM cannot communicate to other control units.

Possible Cause

INFOID:000000001703473

Harness or connectors
(CAN communication line is open or shorted.)

DTC Confirmation Procedure

INFOID:000000001703474

NOTE:

If "DTC Confirmation Procedure" has been previously performed, always turn ignition switch OFF and wait at least 10 seconds before performing the next test.

After the repair, touch "ERASE" on "SELF-DIAG RESULTS" and then perform the following procedure to confirm the malfunction is eliminated.

Ⓟ WITH CONSULT-III

1. Turn ignition switch ON. (Do not start engine.)
2. Select "DATA MONITOR" mode for "TRANSMISSION" with CONSULT-III.
3. Start engine and wait for at least 6 seconds.
4. If DTC is detected, go to [CVT-59. "Diagnosis Procedure"](#).

Ⓢ WITH GST

Follow the procedure "WITH CONSULT-III".

Diagnosis Procedure

INFOID:000000001703475

1. CHECK DTC

Ⓟ With CONSULT-III

1. Turn ignition switch ON. (Do not start engine.)
2. Select "SELF-DIAG RESULTS" mode for "TRANSMISSION" with CONSULT-III.
3. Touch "ERASE".
4. Turn ignition switch OFF and wait for at least 10 seconds.
5. Perform "DTC confirmation procedure". Refer to [CVT-59. "DTC Confirmation Procedure"](#).

Is any malfunction of the "U1010 CONTROL UNIT(CAN)" indicated?

- YES >> Replace the TCM. Refer to [CVT-161. "Removal and Installation"](#).
NO >> **INSPECTION END**

DTC P0615 START SIGNAL CIRCUIT

< SERVICE INFORMATION >

DTC P0615 START SIGNAL CIRCUIT

Description

INFOID:000000001703476

- TCM controls starter relay in IPDM E/R.
- TCM switches starter relay ON at “P” or “N” position and allows to crank engine.
- Then it prohibits cranking other than at “P” or “N” position.

CONSULT-III Reference Value in Data Monitor Mode

INFOID:000000001703477

Item name	Condition	Display value
STRTR RLY OUT	Selector lever in “P” and “N” positions	ON
	Selector lever in other positions	OFF
STRTR RLY MON	Selector lever in “P” and “N” positions	ON
	Selector lever in other positions	OFF

On Board Diagnosis Logic

INFOID:000000001703478

- This is not an OBD-II self-diagnostic item.
- Diagnostic trouble code “P0615 STARTER RELAY/CIRC” with CONSULT-III is detected when starter relay switched ON other than at “P” or “N” position. (or when switched OFF at “P” or “N” position).

Possible Cause

INFOID:000000001703479

- Harness or connectors
(Starter relay and TCM circuit is open or shorted.)
- Starter relay

DTC Confirmation Procedure

INFOID:000000001703480

CAUTION:

Always drive vehicle at a safe speed.

NOTE:

If “DTC Confirmation Procedure” has been previously performed, always turn ignition switch OFF and wait at least 10 seconds before performing the next test.

After the repair, touch “ERASE” on “SELF-DIAG RESULTS” and then perform the following procedure to confirm the malfunction is eliminated.

Ⓟ WITH CONSULT-III

1. Turn ignition switch ON. (Do not start engine.)
2. Select “DATA MONITOR” mode for “TRANSMISSION” with CONSULT-III.
3. Start engine.
4. Drive vehicle for at least 2 consecutive seconds.
5. If DTC is detected, go to [CVT-62. "Diagnosis Procedure"](#) .

DTC P0615 START SIGNAL CIRCUIT

< SERVICE INFORMATION >

Wiring Diagram - CVT - STSIG

INFOID:000000001703481

CVT-STSIG-01

: DETECTABLE LINE FOR DTC
 : NON-DETECTABLE LINE FOR DTC

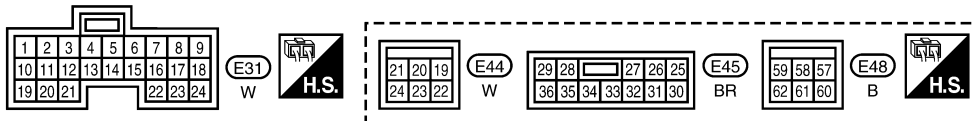
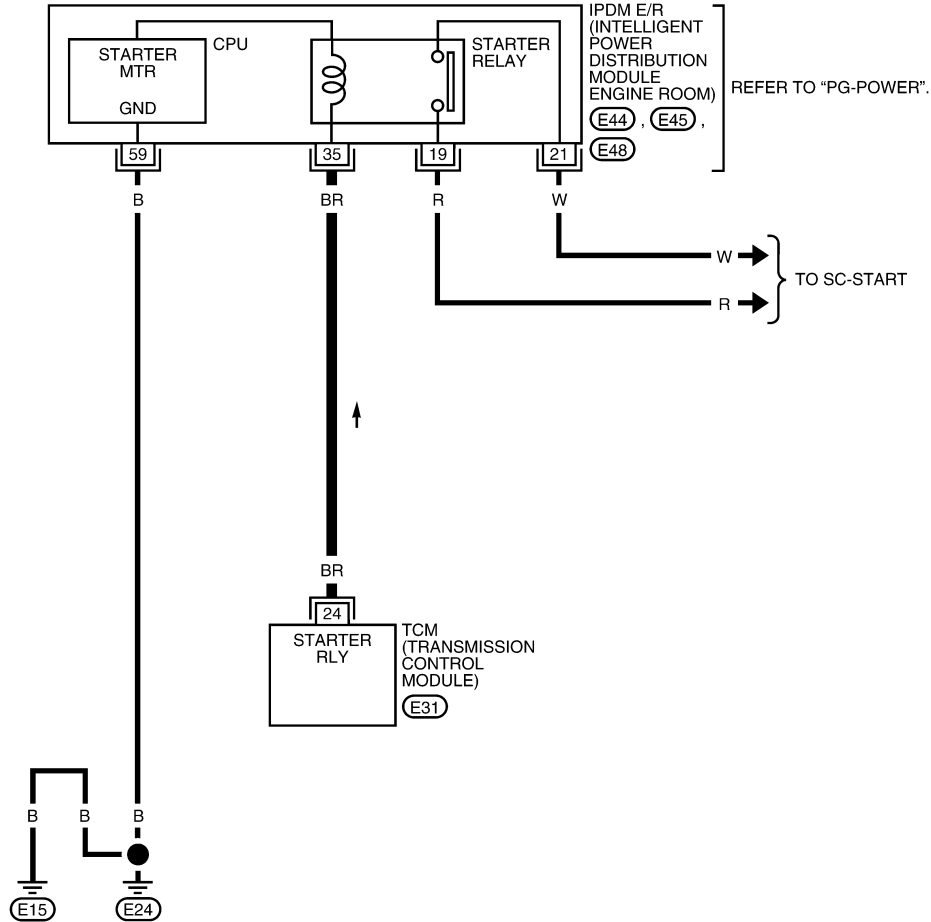

TCM TERMINALS AND REFERENCE VALUES
 Refer to [CVT-45, "TCM Terminal and Reference Value"](#).

BCWA0669E

DTC P0615 START SIGNAL CIRCUIT

< SERVICE INFORMATION >

Diagnosis Procedure

INFOID:000000001703482

1. CHECK STARTER RELAY SIGNAL

④ With CONSULT-III

- Turn ignition switch ON. (Do not start engine.)
- Select "SELECTION FROM MENU" in "DATA MONITOR" mode for "TRANSMISSION" with CONSULT-III and check monitor "STRTR RLY OUT", "STRTR RLY MON"(PNP relay) ON/OFF.

Item name	Condition	Display value
STRTR RLY OUT	Selector lever in "P" and "N" positions	ON
	Selector lever in other positions	OFF
STRTR RLY MON	Selector lever in "P" and "N" positions	ON
	Selector lever in other positions	OFF

⊗ Without CONSULT-III

- Turn ignition switch ON. (Do not start engine.)
- Check voltage between the TCM connector terminal and ground.

Terminal	Item	Condition	Data (Approx.)
24	Starter relay	Selector lever in "N" and "P" positions	Battery voltage
		Selector lever in other positions	0 V

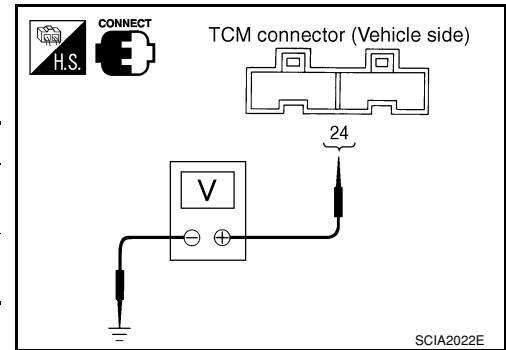

OK or NG

- OK >> GO TO 3.
 NG >> GO TO 2.

2. DETECT MALFUNCTIONING ITEM

Check the following:

- Starter relay. Refer to [PG-69](#).
- Open or short-circuit in the harness between TCM and the starter relay. Refer to [CVT-61, "Wiring Diagram - CVT - STSIG"](#).
- Ground circuit for the starter relay. Refer to [SC-10, "Wiring Diagram - START -"](#).

OK or NG

- OK >> GO TO 3.
 NG >> Repair or replace damaged parts.

3. CHECK DTC

Perform [CVT-60, "DTC Confirmation Procedure"](#).

OK or NG

- OK >> **INSPECTION END**
 NG >> GO TO 4.

4. CHECK TCM

- Check TCM input/output signals. Refer to [CVT-45, "TCM Terminal and Reference Value"](#).
- If NG, re-check TCM pin terminals for damage or loose connection with harness connector.

OK or NG

- OK >> **INSPECTION END**
 NG >> Repair or replace damaged parts.

DTC P0703 STOP LAMP SWITCH CIRCUIT

< SERVICE INFORMATION >

DTC P0703 STOP LAMP SWITCH CIRCUIT

Description

INFOID:000000001703483

ON, OFF status of the stop lamp switch is sent via the CAN communication from the combination meter to TCM using the signal.

CONSULT-III Reference Value in Data Monitor Mode

INFOID:000000001703484

Item name	Condition	Display value
BRAKE SW	Depressed brake pedal	ON
	Released brake pedal	OFF

On Board Diagnosis Logic

INFOID:000000001703485

- This is not an OBD-II self-diagnostic item.
- Diagnostic trouble code "P0703 BRAKE SW/CIRC" with CONSULT-III is detected when the stop lamp switch does not switch to ON and OFF.
- The stop lamp switch does not switch to ON, OFF.

Possible Cause

INFOID:000000001703486

- Harness or connectors
(Stop lamp switch, and combination meter circuit are open or shorted.)
(CAN communication line is open or shorted.)
- Stop lamp switch

DTC Confirmation Procedure

INFOID:000000001703487

CAUTION:

Always drive vehicle at a safe speed.

NOTE:

If "DTC Confirmation Procedure" has been previously performed, always turn ignition switch OFF and wait at least 10 seconds before performing the next test.

After the repair, touch "ERASE" on "SELF-DIAG RESULTS" and then perform the following procedure to confirm the malfunction is eliminated.

④ WITH CONSULT-III

1. Turn ignition switch ON. (Do not start engine.)
2. Select "DATA MONITOR" mode for "TRANSMISSION" with CONSULT-III.
3. Start engine.
4. Start vehicle for at least 3 consecutive seconds.
5. If DTC is detected, go to [CVT-63. "Diagnosis Procedure"](#).

Diagnosis Procedure

INFOID:000000001703488

1. CHECK CAN COMMUNICATION LINE

Perform the self-diagnosis check. Refer to [CVT-47. "CONSULT-III Function \(TRANSMISSION\)"](#).

Is any malfunction of the "U1000 CAN COMM CIRCUIT" indicated?

- YES >> Check CAN communication line. Refer to [CVT-56](#).
NO >> GO TO 2.

2. CHECK STOP LAMP SWITCH CIRCUIT

④ With CONSULT-III

1. Turn ignition switch ON. (Do not start engine.)
2. Select "ECU INPUT SIGNALS" in "DATA MONITOR" mode for "TRANSMISSION" with CONSULT-III.
3. Read out ON/OFF switching action of the "BRAKE SW".

DTC P0703 STOP LAMP SWITCH CIRCUIT

< SERVICE INFORMATION >

Item name	Condition	Display value
BRAKE SW	Depressed brake pedal	ON
	Released brake pedal	OFF

OK or NG

OK >> **INSPECTION END**

NG >> GO TO 3.

3.CHECK STOP LAMP SWITCH

Check continuity between stop lamp switch harness connector E13 terminals 1 and 2. Refer to [CVT-149. "Wiring Diagram - CVT - NON-DTC"](#).

Condition	Continuity
When brake pedal is depressed	Yes
When brake pedal is released	No

Check stop lamp switch after adjusting brake pedal — refer to [BR-5](#).

OK or NG

OK >> Check the following. If NG, repair or replace damaged parts.

- Harness for short or open between battery and stop lamp switch.
- Harness for short or open between stop lamp switch and combination meter.

NG >> Repair or replace the stop lamp switch.

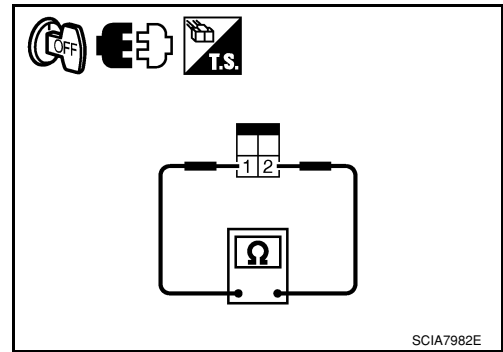

DTC P0705 PARK/NEUTRAL POSITION SWITCH

< SERVICE INFORMATION >

DTC P0705 PARK/NEUTRAL POSITION SWITCH

Description

INFOID:000000001703489

- The PNP switch is included in the control valve assembly.
- The PNP switch includes 4 transmission position switches.
- TCM judges the selector lever position by the PNP switch signal.

Shift position	PNP switch 1	PNP switch 2	PNP switch 3	PNP switch 4	PNP switch 3 (monitor)
P	OFF	OFF	OFF	OFF	OFF
R	ON	OFF	OFF	ON	OFF
N	ON	ON	OFF	OFF	OFF
D	ON	ON	ON	ON	ON
L	OFF	ON	ON	OFF	ON

CONSULT-III Reference Value in Data Monitor Mode

INFOID:000000001703490

Item name	Condition	Display value
INH SW3M	Selector lever in "D" and "L" positions	ON
	Selector lever in "P", "R" and "N" positions	OFF
INH SW4	Selector lever in "R" and "D" positions	ON
	Selector lever in "P", "N" and "L" positions	OFF
INH SW3	Selector lever in "D" and "L" positions	ON
	Selector lever in "P", "R" and "N" positions	OFF
INH SW2	Selector lever in "N", "D" and "L" positions	ON
	Selector lever in "P" and "R" positions	OFF
INH SW1	Selector lever in "R", "N" and "D" positions	ON
	Selector lever in "P" and "L" positions	OFF

On Board Diagnosis Logic

INFOID:000000001703491

- This is an OBD-II self-diagnostic item.
- Diagnostic trouble code "P0705 PNP SW/CIRC" with CONSULT-III is detected under the following conditions.
 - When TCM does not receive the correct voltage signal from the PNP switches 1, 2, 3 and 4 based on the gear position.
 - When the signal from monitor terminal of PNP switch 3 is different from PNP switch 3.

Possible Cause

INFOID:000000001703492

- Harness or connectors (PNP switches 1, 2, 3, 4 and TCM circuit is open or shorted.)
- PNP switches 1, 2, 3, 4
- PNP switch 3 monitor terminal is open or shorted

DTC Confirmation Procedure

INFOID:000000001703493

CAUTION:

Always drive vehicle at a safe speed.

NOTE:

If "DTC Confirmation Procedure" has been previously performed, always turn ignition switch OFF and wait at least 10 seconds before performing the next test.

After the repair, touch "ERASE" on "SELF-DIAG RESULTS" and then perform the following procedure to confirm the malfunction is eliminated.

 WITH CONSULT-III

DTC P0705 PARK/NEUTRAL POSITION SWITCH

< SERVICE INFORMATION >

1. Turn ignition switch ON. (Do not start engine.)
2. Select "DATA MONITOR" mode for "TRANSMISSION" with CONSULT-III.
3. Start engine.
4. Drive vehicle and maintain the following conditions for at least 2 consecutive seconds.
VEHICLE SPEED: More than 10 km/h (6 MPH)
ENG SPEED: More than 450 rpm
ACC PEDAL OPEN: More than 1.0/8
5. If DTC is detected, go to [CVT-68, "Diagnosis Procedure"](#) .

WITH GST

Follow the procedure "WITH CONSULT-III".

DTC P0705 PARK/NEUTRAL POSITION SWITCH

< SERVICE INFORMATION >

Wiring Diagram - CVT - PNP/SW

INFOID:000000001703494

CVT-PNP/SW-01

: DETECTABLE LINE FOR DTC
 : NON-DETECTABLE LINE FOR DTC

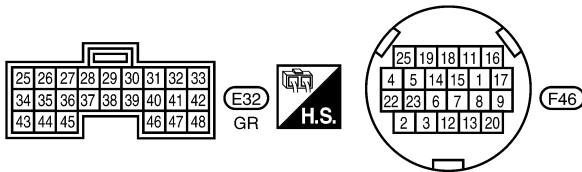
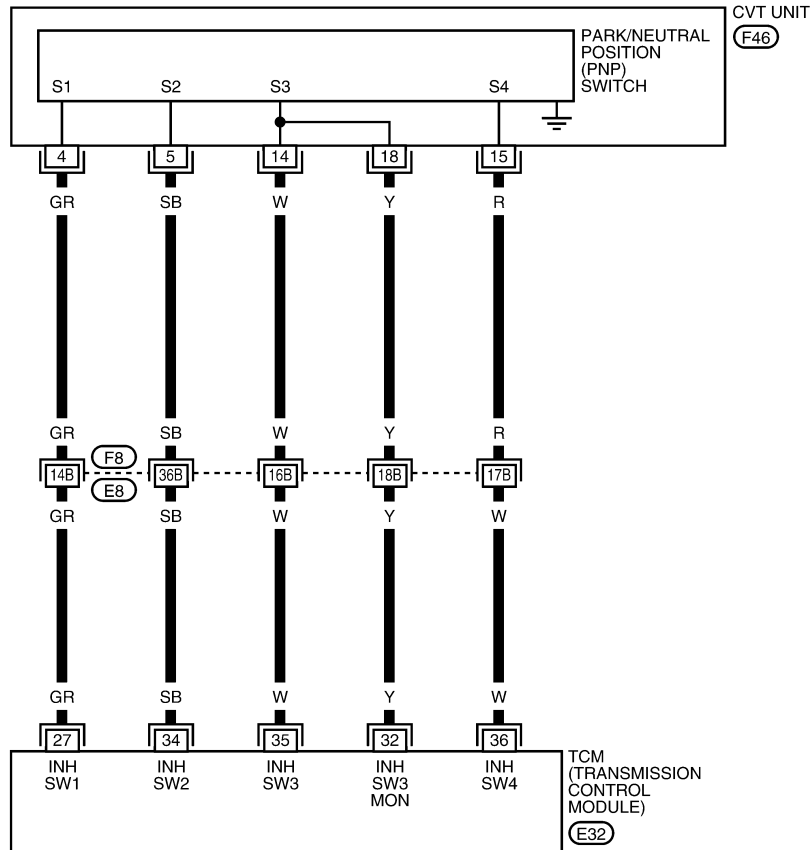

REFER TO THE FOLLOWING.

(F8) - SUPER MULTIPLE JUNCTION (SMJ)

TCM TERMINALS AND REFERENCE VALUES
 Refer to [CVT-45, "TCM Terminal and Reference Value"](#).

DTC P0705 PARK/NEUTRAL POSITION SWITCH

< SERVICE INFORMATION >

Diagnosis Procedure

INFOID:000000001703495

1. CHECK PNP SW SIGNALS

④ With CONSULT-III

1. Turn ignition switch ON. (Do not start engine.)
2. Select "ECU INPUT SIGNALS" in "DATA MONITOR" mode for "TRANSMISSION" with CONSULT-III.
3. Change selector lever to "P", "R", "N", "D" and "L" positions to check the value of "INH SW1" "INH SW2" "INH SW3" "INH SW4" and "INH SW3M".

Shift position	"INH SW1"	"INH SW2"	"INH SW3"	"INH SW4"	"INH SW3M"
P	OFF	OFF	OFF	OFF	OFF
R	ON	OFF	OFF	ON	OFF
N	ON	ON	OFF	OFF	OFF
D	ON	ON	ON	ON	ON
L	OFF	ON	ON	OFF	ON

⊗ Without CONSULT-III

1. Turn ignition switch ON. (Do not start engine.)
2. Change selector lever to "P", "R", "N", "D" and "L" positions to check voltage between the TCM connector terminals and ground.

Shift position	Connector		E32			
	Terminal					
	27 - Ground	34 - Ground	35 - Ground	36 - Ground	32 - Ground	
P	Battery voltage	10.0 V - Battery voltage	8.0 V - Battery voltage	10.0 V - Battery voltage	8.0 V - Battery voltage	
R	0 V	10.0 V - Battery voltage	8.0 V - Battery voltage	0 V	8.0 V - Battery voltage	
N	0 V	0 V	8.0 V - Battery voltage	10.0 V - Battery voltage	8.0 V - Battery voltage	
D	0 V	0 V	0 V	0 V	0 V	
L	Battery voltage	0 V	0 V	10.0 V - Battery voltage	0 V	

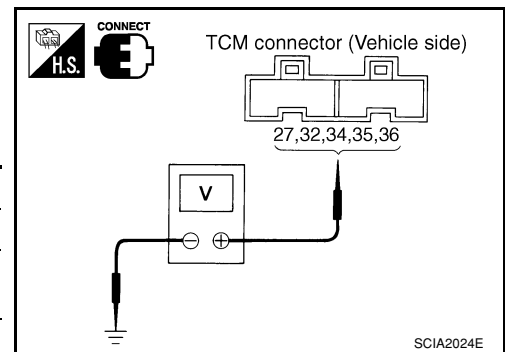

OK or NG

- OK >> GO TO 5.
 NG >> GO TO 2.

2. CHECK PNP SWITCH CIRCUIT

1. Turn ignition switch OFF.
2. Disconnect TCM connector.

DTC P0705 PARK/NEUTRAL POSITION SWITCH

< SERVICE INFORMATION >

3. Check continuity between TCM connector terminals and ground.

Connector	Terminal	Condition	Continuity
E32	27 - ground	Select lever in "P" and "L" positions	No
		Select lever in other positions	Yes
	34 - ground	Select lever in "P" and "R" positions	No
		Select lever in other positions	Yes
	35 - ground	Select lever in "P", "R" and "N" positions	No
		Select lever in other positions	Yes
	36 - ground	Select lever in "P", "N" and "L" positions	No
		Select lever in other positions	Yes
32 - ground	Select lever in "P", "R" and "N" positions	No	
	Select lever in other positions	Yes	

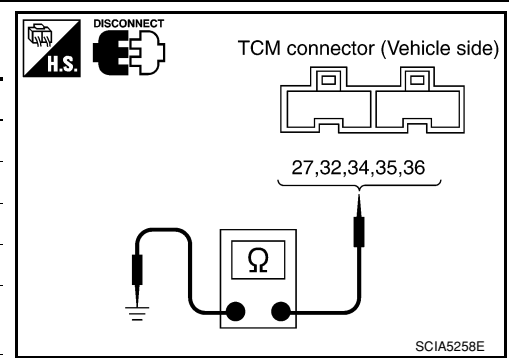

4. If OK, check harness for short-circuit to ground or power supply.

OK or NG

- OK >> GO TO 5.
- NG >> GO TO 3.

3. CHECK HARNESS BETWEEN TCM AND PNP SWITCH

1. Turn ignition switch OFF.
2. Disconnect TCM connector and CVT unit harness connector.
3. Check continuity between TCM connector terminals and CVT unit harness connector terminals.

Item	Connector	Terminal	Continuity
TCM	E32	27	Yes
CVT unit harness connector	F46	4	
TCM	E32	34	Yes
CVT unit harness connector	F46	5	
TCM	E32	35	Yes
CVT unit harness connector	F46	14	
TCM	E32	32	Yes
CVT unit harness connector	F46	18	
TCM	E32	36	Yes
CVT unit harness connector	F46	15	

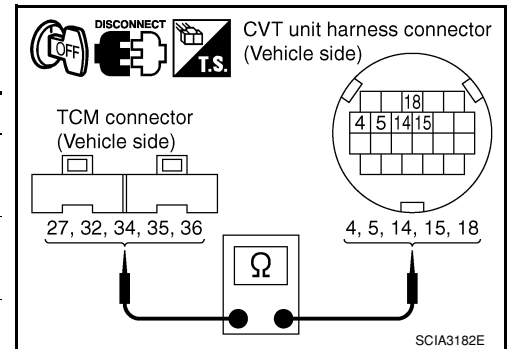

4. If OK, check harness for short to ground and short to power.

5. Reinstall any part removed.

OK or NG

- OK >> GO TO 4.
- NG >> Repair or replace damaged parts.

4. DETECT MALFUNCTIONING ITEM

Check PNP switch. Refer to [CVT-70, "Component Inspection"](#).

OK or NG

- OK >> GO TO 5.
- NG >> Repair or replace damaged parts.

5. CHECK DTC

Perform [CVT-65, "DTC Confirmation Procedure"](#).

DTC P0705 PARK/NEUTRAL POSITION SWITCH

< SERVICE INFORMATION >

OK or NG

- OK >> **INSPECTION END**
- NG >> GO TO 6.

6. CHECK TCM

1. Check TCM input/output signals. Refer to [CVT-45. "TCM Terminal and Reference Value"](#).
2. If NG, re-check TCM pin terminals for damage or loose connection with harness connector.

OK or NG

- OK >> **INSPECTION END**
- NG >> 1. Repair or replace damaged parts.
- 2. Replace the transaxle assembly. Refer to [CVT-178. "Removal and Installation"](#).

Component Inspection

INFOID:000000001703496

PNP SWITCH

1. Change selector lever to various positions to check the continuity between terminals on the PNP switch and ground.

PNP SW	Shift position	Connector	Terminal	Continuity
SW 1	"R", "N", "D"	F46	4 - Ground	Yes
	other positions			No
SW 2	"N", "D", "L"		5 - Ground	Yes
	other positions			No
SW 3	"D", "L"		14 - Ground	Yes
	other positions			No
SW 4	"R", "D"		15 - Ground	Yes
	other positions			No
SW 3 Monitor	"D", "L"		18 - Ground	Yes
	other positions			No

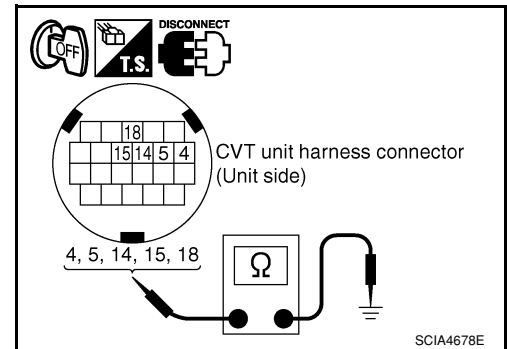

2. If NG, check continuity with control cable disconnected. (Refer to step 1 above.)
3. If OK, with the control cable disconnected, adjust the control cable. Refer to [CVT-171. "Adjustment of CVT Position"](#).
4. If NG, even when the control cable is disconnected, replace the transaxle assembly. Refer to [CVT-178. "Removal and Installation"](#).

DTC P0710 CVT FLUID TEMPERATURE SENSOR CIRCUIT

< SERVICE INFORMATION >

DTC P0710 CVT FLUID TEMPERATURE SENSOR CIRCUIT

Description

INFOID:000000001703497

- The CVT fluid temperature sensor is included in the control valve assembly.
- The CVT fluid temperature sensor detects the CVT fluid temperature and sends a signal to the TCM.

CONSULT-III Reference Value in Data Monitor Mode

INFOID:000000001703498

Remarks: Specification data are reference values.

Item name	Condition	Display value (Approx.)
ATF TEMP SEN	When CVT fluid temperature is 20°C (68°F).	2.0 V
	When CVT fluid temperature is 80°C (176°F).	1.0 V

On Board Diagnosis Logic

INFOID:000000001703499

- This is an OBD-II self-diagnostic item.
- Diagnostic trouble code “P0710 ATF TEMP SEN/CIRC” with CONSULT-III is detected when TCM receives an excessively low or high voltage from the sensor.

Possible Cause

INFOID:000000001703500

- Harness or connectors
(Sensor circuit is open or shorted.)
- CVT fluid temperature sensor

DTC Confirmation Procedure

INFOID:000000001703501

CAUTION:

Always drive vehicle at a safe speed.

NOTE:

If “DTC Confirmation Procedure” has been previously performed, always turn ignition switch OFF and wait at least 10 seconds before performing the next test.

After the repair, touch “ERASE” on “SELF-DIAG RESULTS” and then perform the following procedure to confirm the malfunction is eliminated.

Ⓜ WITH CONSULT-III

1. Turn ignition switch ON. (Do not start engine.)
2. Select “DATA MONITOR” mode for “TRANSMISSION” with CONSULT-III.
3. Start engine and maintain the following conditions for at least 10 minutes (Total).
VEHICLE SPEED: 10 km/h (6 MPH) or more
ENG SPEED: 450 rpm more than
ACC PEDAL OPEN: More than 1.0/8
RANGE: “D” position
4. If DTC is detected, go to [CVT-73. "Diagnosis Procedure"](#).

Ⓜ WITH GST

Follow the procedure “WITH CONSULT-III”.

DTC P0710 CVT FLUID TEMPERATURE SENSOR CIRCUIT

< SERVICE INFORMATION >

Wiring Diagram - CVT - FTS

INFOID:000000001703502

CVT-FTS-01

— : DETECTABLE LINE FOR DTC
 - - - : NON-DETECTABLE LINE FOR DTC

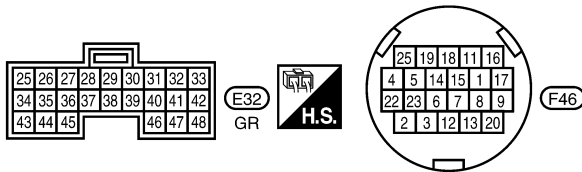
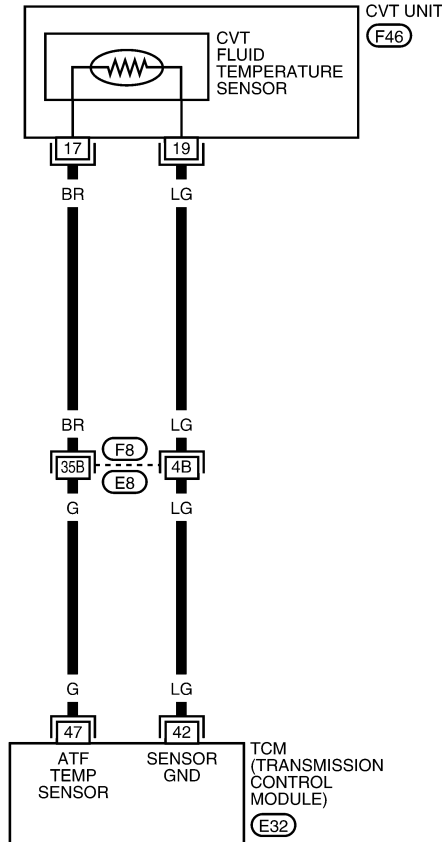

REFER TO THE FOLLOWING.

(F8) - SUPER MULTIPLE JUNCTION (SMJ)

BCWA0671E

TCM TERMINALS AND REFERENCE VALUES

Refer to [CVT-45, "TCM Terminal and Reference Value"](#).

DTC P0710 CVT FLUID TEMPERATURE SENSOR CIRCUIT

< SERVICE INFORMATION >

INFOID:000000001703503

Diagnosis Procedure

1. CHECK CVT FLUID TEMPERATURE SENSOR SIGNAL

④ With CONSULT-III

1. Start engine.
2. Select "ECU INPUT SIGNALS" in "DATA MONITOR" mode for "TRANSMISSION" with CONSULT-III.
3. Read out the value of "ATF TEMP SEN".

Item name	Condition	Display value (Approx.)
ATF TEMP SEN	When CVT fluid temperature is 20°C (68°F).	2.0 V
	When CVT fluid temperature is 80°C (176°F).	1.0 V

⊗ Without CONSULT-III

1. Start engine.
2. Check voltage between TCM connector terminals.

Name	Connector	Terminal	Temperature °C (°F)	Voltage (Approx.)
CVT fluid temperature sensor	E32	47 - 42	20 (68)	2.0 V
			80 (176)	1.0 V

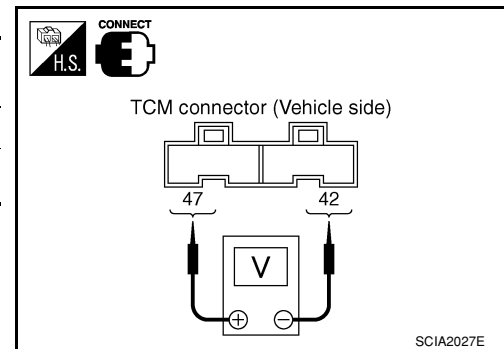

3. Turn ignition switch OFF.
4. Disconnect TCM connector.
5. Check if there is continuity between connector terminal and ground.

OK or NG

- OK >> GO TO 5.
 NG >> GO TO 2.

2. CHECK CVT FLUID TEMPERATURE SENSOR CIRCUIT

1. Turn ignition switch OFF.
2. Disconnect the TCM connector.
3. Check resistance between TCM connector terminals.

Name	Connector	Terminal	Temperature °C (°F)	Resistance (Approx.)
CVT fluid temperature sensor	E32	47 - 42	20 (68)	6.5 kΩ
			80 (176)	0.9 kΩ

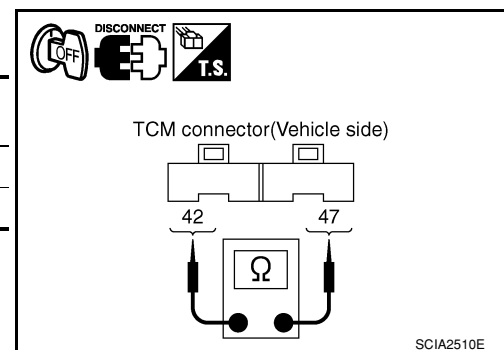

OK or NG

- OK >> GO TO 5.
 NG >> GO TO 3.

3. CHECK CVT FLUID TEMPERATURE SENSOR

1. Turn ignition switch OFF.
2. Disconnect CVT unit harness connector.

DTC P0710 CVT FLUID TEMPERATURE SENSOR CIRCUIT

< SERVICE INFORMATION >

3. Check resistance between CVT unit harness connector terminals.

Name	Connector	Terminal	Temperature °C (°F)	Resistance (Approx.)
CVT fluid temperature sensor	F46	17 - 19	20 (68)	6.5 kΩ
			80 (176)	0.9 kΩ

4. Reinstall any part removed.

OK or NG

OK >> GO TO 4.

NG >> Replace the transaxle assembly. Refer to [CVT-178. "Removal and Installation"](#).

4. CHECK HARNESS BETWEEN TCM AND CVT FLUID TEMPERATURE SENSOR

1. Turn ignition switch OFF.
2. Disconnect the TCM connector and CVT unit harness connector.
3. Check continuity between TCM connector terminals and CVT unit harness connector terminals.

Item	Connector	Terminal	Continuity
TCM	E32	42	Yes
CVT unit harness connector	F46	19	
TCM	E32	47	Yes
CVT unit harness connector	F46	17	

4. If OK, check harness for short to ground and short to power.
5. Reinstall any part removed.

OK or NG

OK >> GO TO 5.

NG >> Repair or replace damaged parts.

5. CHECK DTC

Perform [CVT-71. "DTC Confirmation Procedure"](#).

OK or NG

OK >> **INSPECTION END**

NG >> GO TO 6.

6. CHECK TCM

1. Check TCM input/output signals. Refer to [CVT-45. "TCM Terminal and Reference Value"](#).
2. If NG, re-check TCM pin terminals for damage or loose connection with harness connector.

OK or NG

OK >> **INSPECTION END**

NG >> Repair or replace damaged parts.

Component Inspection

CVT FLUID TEMPERATURE SENSOR

1. Turn ignition switch OFF.
2. Disconnect CVT unit harness connector.

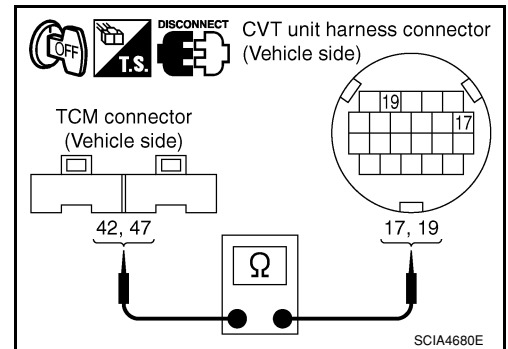
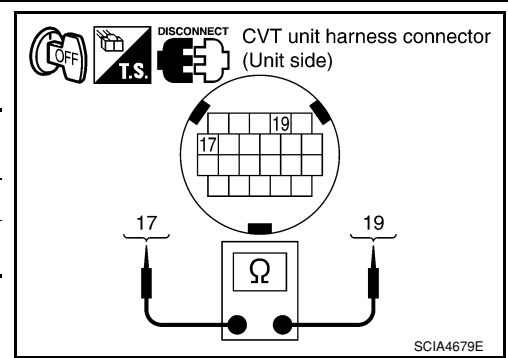

INFOID:000000001703504

DTC P0710 CVT FLUID TEMPERATURE SENSOR CIRCUIT

< SERVICE INFORMATION >

3. Check resistance between CVT unit harness connector terminals.

Name	Connector	Terminal	Temperature °C (°F)	Resistance (Approx.)
CVT fluid temperature sensor	F46	17 - 19	20 (68)	6.5 kΩ
			80 (176)	0.9 kΩ

4. If NG, replace the transaxle assembly. Refer to [CVT-178](#). ["Removal and Installation"](#).

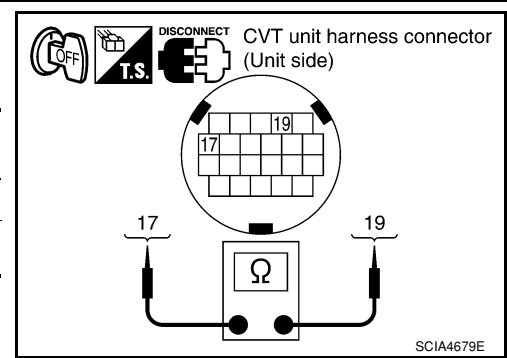

A
B
CVT
D
E
F
G
H
I
J
K
L
M
N
O
P

DTC P0715 INPUT SPEED SENSOR CIRCUIT (PRI SPEED SENSOR)

< SERVICE INFORMATION >

DTC P0715 INPUT SPEED SENSOR CIRCUIT (PRI SPEED SENSOR)

Description

INFOID:000000001703505

- The input speed sensor (primary speed sensor) is included in the control valve assembly.
- The input speed sensor (primary speed sensor) detects the primary pulley revolution speed and sends a signal to the TCM.

CONSULT-III Reference Value in Data Monitor Mode

INFOID:000000001703506

Remarks: Specification data are reference values.

Item name	Condition	Display value
ENG SPEED SIG	Engine running	Closely matches the tachometer reading.
PRI SPEED SEN	During driving (lock-up ON)	Approximately matches the engine speed.

On Board Diagnosis Logic

INFOID:000000001703507

- This is an OBD-II self-diagnostic item.
- Diagnostic trouble code "P0715 INPUT SPD SEN/CIRC" with CONSULT-III is detected when TCM does not receive the proper signal from the sensor.

Possible Cause

INFOID:000000001703508

- Harness or connectors
(Sensor circuit is open or shorted.)
- Input speed sensor (Primary speed sensor)

DTC Confirmation Procedure

INFOID:000000001703509

CAUTION:

Always drive vehicle at a safe speed.

NOTE:

If "DTC Confirmation Procedure" has been previously performed, always turn ignition switch OFF and wait at least 10 seconds before performing the next test.

After the repair, touch "ERASE" on "SELF-DIAG RESULTS" and then perform the following procedure to confirm the malfunction is eliminated.

④ WITH CONSULT-III

1. Turn ignition switch ON and select "DATA MONITOR" mode for "TRANSMISSION" with CONSULT-III.
2. Start engine and maintain the following conditions for at least 5 consecutive seconds.
VEHICLE SPEED: 10 km/h (6 MPH) or more
ACC PEDAL OPEN: More than 1.0/8
RANGE: "D" position
ENG SPEED: 450 rpm or more
Driving location: Driving the vehicle uphill (increased engine load) will help maintain the driving conditions required for this test.
3. If DTC is detected, go to [CVT-78. "Diagnosis Procedure"](#) .

④ WITH GST

Follow the procedure "WITH CONSULT-III".

DTC P0715 INPUT SPEED SENSOR CIRCUIT (PRI SPEED SENSOR)

< SERVICE INFORMATION >

Wiring Diagram - CVT - PRSCVT

INFOID:000000001703510

CVT-PRSCVT-01

: DETECTABLE LINE FOR DTC
 : NON-DETECTABLE LINE FOR DTC

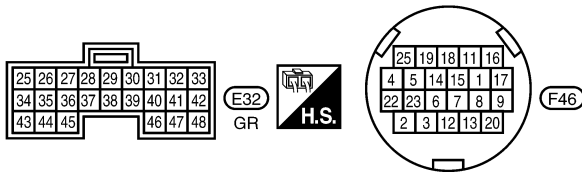
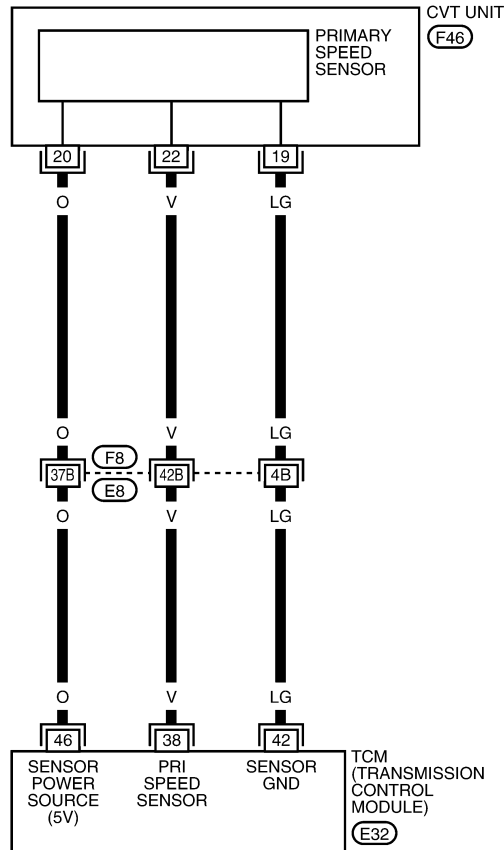

REFER TO THE FOLLOWING.

(F8) - SUPER MULTIPLE JUNCTION (SMJ)

TCM TERMINALS AND REFERENCE VALUES
 Refer to [CVT-45, "TCM Terminal and Reference Value"](#).

BCWA0672E

DTC P0715 INPUT SPEED SENSOR CIRCUIT (PRI SPEED SENSOR)

< SERVICE INFORMATION >

INFOID:000000001703511

Diagnosis Procedure

1. CHECK INPUT SIGNALS

With CONSULT-III

1. Start engine.
2. Select "ECU INPUT SIGNALS" in "DATA MONITOR" mode for "TRANSMISSION" with CONSULT-III.
3. Start vehicle and read out the value of "PRI SPEED SEN".

Item name	Condition	Display value
PRI SPEED SEN	During driving (lock-up ON)	Approximately matches the engine speed.

OK or NG

- OK >> GO TO 6.
 NG >> GO TO 2.

2. CHECK INPUT SPEED SENSOR (PRIMARY SPEED SENSOR)

1. Start engine.
2. Check voltage between TCM connector terminals.

Item	Connector	Terminal	Data (Approx.)
TCM	E32	46 - 42	5.0 V

3. Check the pulse with CONSULT-III or oscilloscope, when vehicle cruises.

Name	Condition
Input speed sensor (Primary speed sensor)	When running at 20 km/h (12 MPH) in "L" position with the closed throttle position signal OFF, use the CONSULT-III pulse frequency measuring function. CAUTION: Connect the data link connector to the vehicle-side diagnosis connector.

Item	Connector	Terminal	Name	Data (Approx.)
TCM	E32	38	Input speed sensor (Primary speed sensor)	1000 Hz

OK or NG

- OK >> GO TO 6.
 NG - 1 >> Battery voltage is not supplied: GO TO 3.
 NG - 2 >> Battery voltage is supplied, but there is a malfunction in the frequency: GO TO 4.

3. CHECK HARNESS BETWEEN TCM AND CVT UNIT HARNESS CONNECTOR (SENSOR POWER AND SENSOR GROUND)

1. Turn ignition switch OFF.
2. Disconnect TCM connector and CVT unit harness connector.

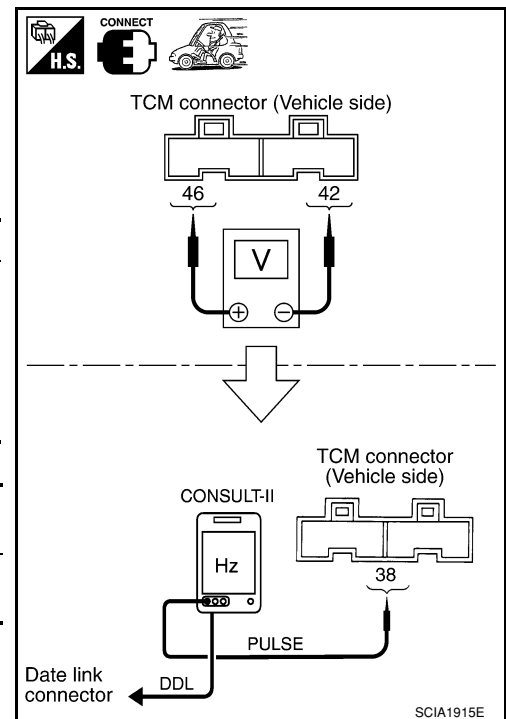

DTC P0715 INPUT SPEED SENSOR CIRCUIT (PRI SPEED SENSOR)

< SERVICE INFORMATION >

3. Check continuity between TCM connector terminals and CVT unit harness connector terminals.

Item	Connector	Terminal	Continuity
TCM	E32	42	Yes
CVT unit harness connector	F46	19	
TCM	E32	46	Yes
CVT unit harness connector	F46	20	

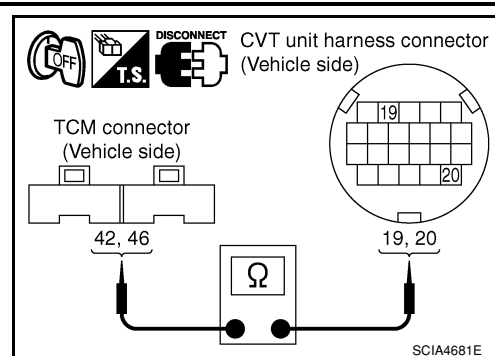

4. If OK, check harness for short to ground and short to power.
5. Reinstall any part removed.

OK or NG

OK >> GO TO 6.

NG >> Repair open circuit or short to ground or short to power in harness or connectors.

4. CHECK HARNESS BETWEEN TCM AND CVT UNIT HARNESS CONNECTOR [INPUT SPEED SENSOR (PRIMARY SPEED SENSOR)]

1. Turn ignition switch OFF.
2. Disconnect TCM connector and CVT unit harness connector.
3. Check continuity between TCM connector terminal and CVT unit harness connector terminal.

Item	Connector	Terminal	Continuity
TCM	E32	38	Yes
CVT unit harness connector	F46	22	

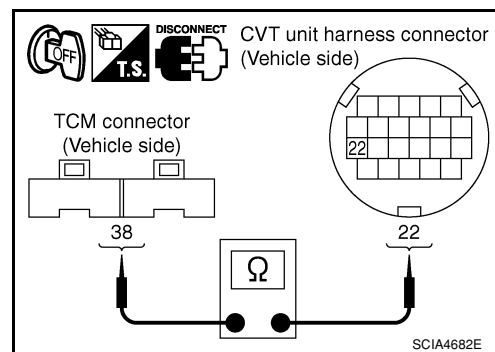

4. If OK, check harness for short to ground and short to power.
5. Reinstall any part removed.

OK or NG

OK >> GO TO 5.

NG >> Repair open circuit or short to ground or short to power in harness or connectors.

5. CHECK THE TCM SHORT

Replace same type TCM, perform self-diagnosis check. Erase self-diagnostic results and then drive the vehicle [10 km/h (6 MPH) or more], perform self-diagnosis check. Refer to [CVT-76. "DTC Confirmation Procedure"](#)

Is the "P0715 INPUT SPD SEN/CIRC" detected again?

YES >> Replace the transaxle assembly. Refer to [CVT-178. "Removal and Installation"](#).

NO >> Replace TCM. Refer to [CVT-8. "Service After Replacing TCM and Transaxle Assembly"](#).

6. CHECK DTC

Perform [CVT-76. "DTC Confirmation Procedure"](#).

OK or NG

OK >> **INSPECTION END**

NG >> GO TO 7.

7. CHECK TCM

1. Check TCM input/output signals. Refer to [CVT-45. "TCM Terminal and Reference Value"](#).
2. If NG, re-check TCM pin terminals for damage or loose connection with harness connector.

OK or NG

OK >> **INSPECTION END**

NG >> Repair or replace damaged parts.

DTC P0720 VEHICLE SPEED SENSOR CVT (SECONDARY SPEED SENSOR)

< SERVICE INFORMATION >

DTC P0720 VEHICLE SPEED SENSOR CVT (SECONDARY SPEED SENSOR)

Description

INFOID:000000001703512

The vehicle speed sensor CVT [output speed sensor (secondary speed sensor)] detects the revolution of the CVT output shaft and emits a pulse signal. The pulse signal is sent to the TCM, which converts it into vehicle speed.

CONSULT-III Reference Value in Data Monitor Mode

INFOID:000000001703513

Remarks: Specification data are reference values.

Item name	Condition	Display value
VSP SENSOR	During driving	Approximately matches the speedometer reading.

On Board Diagnosis Logic

INFOID:000000001703514

- This is an OBD-II self-diagnostic item.
- Diagnostic trouble code "P0720 VEH SPD SEN/CIR AT" with CONSULT-III is detected TCM does not receive the proper signal from the sensor.

Possible Cause

INFOID:000000001703515

- Harness or connectors
(Sensor circuit is open or shorted.)
- Output speed sensor (Secondary speed sensor)

DTC Confirmation Procedure

INFOID:000000001703516

CAUTION:

Always drive vehicle at a safe speed.

NOTE:

If "DTC Confirmation Procedure" has been previously performed, always turn ignition switch OFF and wait at least 10 seconds before performing the next test.

After the repair, touch "ERASE" on "SELF-DIAG RESULTS" and then perform the following procedure to confirm the malfunction is eliminated.

Ⓟ WITH CONSULT-III

1. Turn ignition switch ON and select "DATA MONITOR" mode for "TRANSMISSION" with CONSULT-III.
2. Start engine and maintain the following conditions for at least 12 consecutive seconds.
ACC PEDAL OPEN: More than 1.0/8
RANGE: "D" position
Driving location: Driving the vehicle uphill (increased engine load) will help maintain the driving conditions required for this test.
3. If DTC is detected, go to [CVT-82, "Diagnosis Procedure"](#).

Ⓟ WITH GST

Follow the procedure "WITH CONSULT-III".

DTC P0720 VEHICLE SPEED SENSOR CVT (SECONDARY SPEED SENSOR)

< SERVICE INFORMATION >

Wiring Diagram - CVT - SESCOVT

INFOID:000000001703517

A
B
C
D
E
F
G
H
I
J
K
L
M
N
O
P

CVT

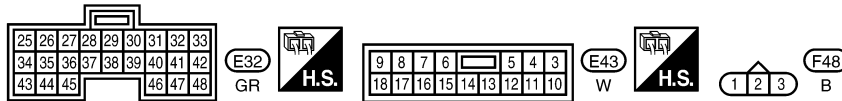
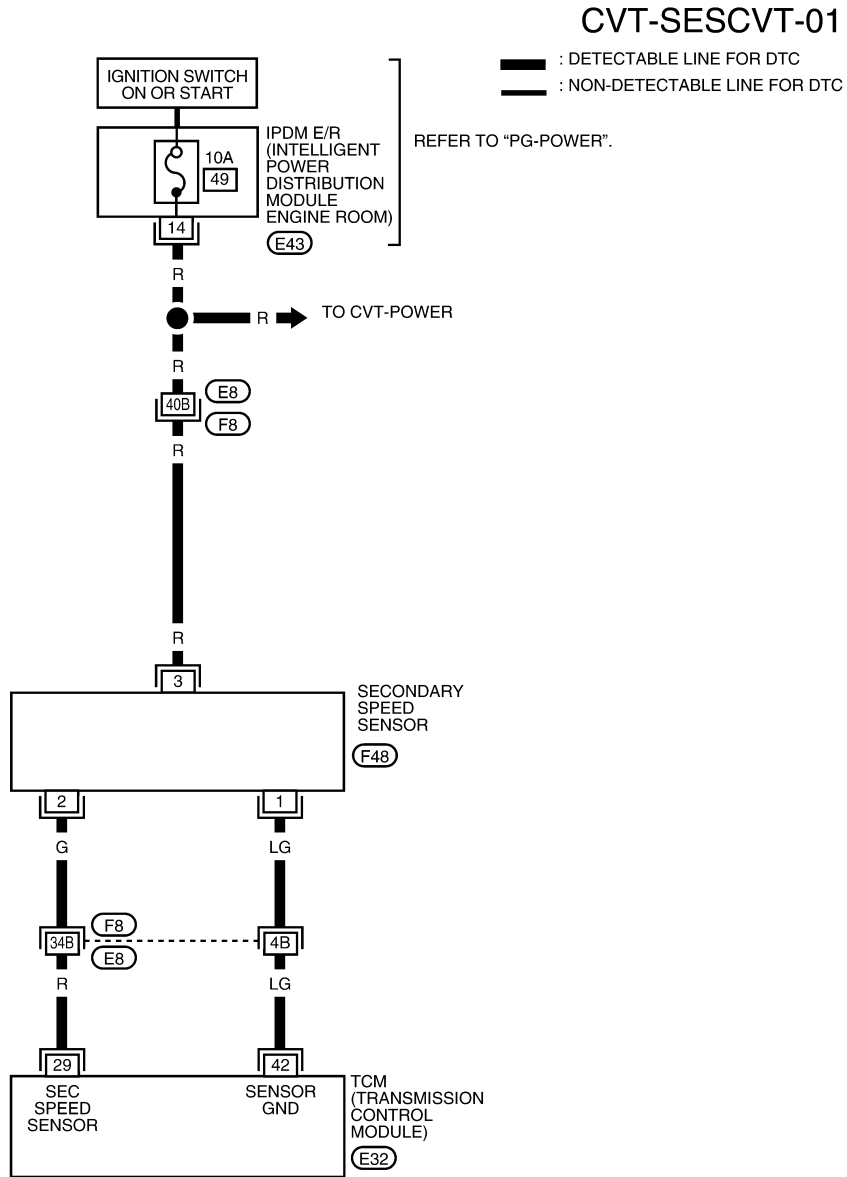

REFER TO THE FOLLOWING.
 (F8) - SUPER MULTIPLE JUNCTION (SMJ)

TCM TERMINALS AND REFERENCE VALUES
 Refer to [CVT-45, "TCM Terminal and Reference Value"](#).

BCWA0673E

DTC P0720 VEHICLE SPEED SENSOR CVT (SECONDARY SPEED SENSOR)

< SERVICE INFORMATION >

INFOID:000000001703518

Diagnosis Procedure

1. CHECK INPUT SIGNAL

With CONSULT-III

1. Start engine.
2. Select "ECU INPUT SIGNALS" in "DATA MONITOR" mode for "TRANSMISSION" with CONSULT-III.
3. Start vehicle and read out the value of "VSP SENSOR".

Item name	Condition	Display value
VSP SENSOR	During driving	Approximately matches the speedometer reading.

OK or NG

- OK >> GO TO 8.
 NG >> GO TO 2.

2. CHECK SECONDARY SPEED SENSOR

With CONSULT-III

1. Start engine.
2. Check power supply to output speed sensor (secondary speed sensor) by voltage between TCM connector terminals 10, 19 and 42. Refer to [CVT-36. "Circuit Diagram"](#).

Item	Connector	Terminal	Data (Approx.)
TCM	E31, E32	10 - 42	Battery voltage
		19 - 42	

3. If OK, check the pulse when vehicle cruises.

Name	Condition
Output speed sensor (Secondary speed sensor)	When running at 20 km/h (12 MPH) in "D" position, use the CONSULT-III pulse frequency measuring function. CAUTION: Connect the data link connector to the vehicle-side diagnosis connector.

Item	Connector	Terminal	Name	Data (Approx.)
TCM	E32	29	Output speed sensor (Secondary speed sensor)	570 Hz

OK or NG

- OK >> GO TO 8.
 NG >> GO TO 3.

3. CHECK POWER AND SENSOR GROUND

1. Turn ignition switch OFF.
2. Disconnect the output speed sensor (secondary speed sensor) harness connector.
3. Turn ignition switch ON.

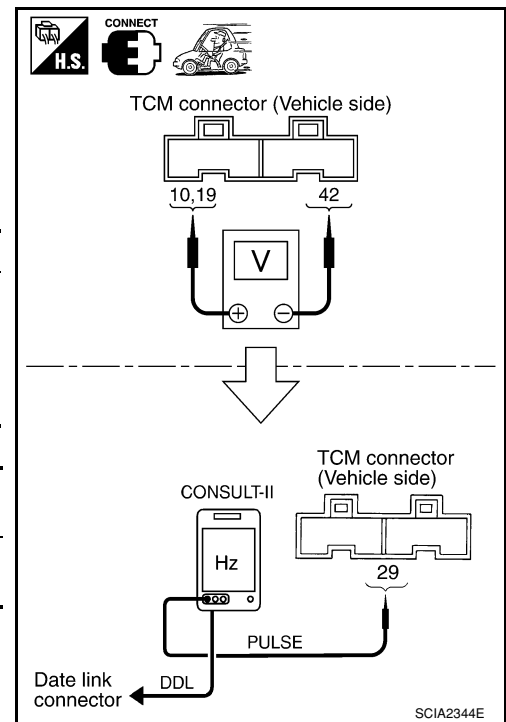

DTC P0720 VEHICLE SPEED SENSOR CVT (SECONDARY SPEED SENSOR)

< SERVICE INFORMATION >

- Check voltage between output speed sensor (secondary speed sensor) harness connector terminals.

Item	Connector	Terminal	Data (Approx.)
Output speed sensor (Secondary speed sensor)	F48	3 - 1	Battery voltage

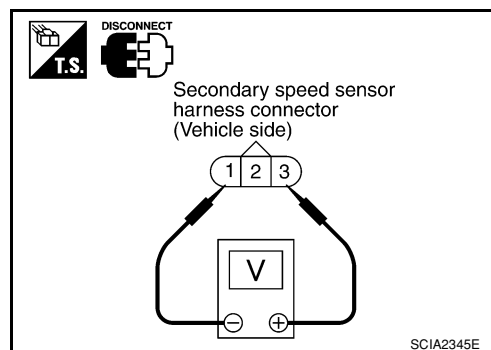

- Check voltage between output speed sensor (secondary speed sensor) harness connector terminal and ground.

Item	Connector	Terminal	Data (Approx.)
Output speed sensor (Secondary speed sensor)	F48	3 - ground	Battery voltage

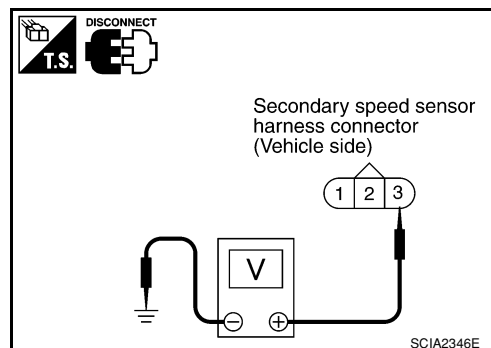

- If OK, check harness for short to ground and short to power.
- Reinstall any part removed.

OK or NG

OK >> GO TO 4.

NG - 1 >> Battery voltage is not supplied between terminals 1 and 3, terminals 1 and ground.: GO TO 6.

NG - 2 >> Battery voltage is not supplied between terminals 1 and 3 only.: GO TO 7.

4. CHECK HARNESS BETWEEN TCM AND OUTPUT SPEED SENSOR (SECONDARY SPEED SENSOR)

- Turn ignition switch OFF.
- Disconnect TCM connector and output speed sensor (secondary speed sensor) harness connector.
- Check continuity between TCM connector terminal and output speed sensor (secondary speed sensor) harness connector terminal.

Item	Connector	Terminal	Continuity
TCM	E32	29	Yes
Output speed sensor (Secondary speed sensor)	F48	2	

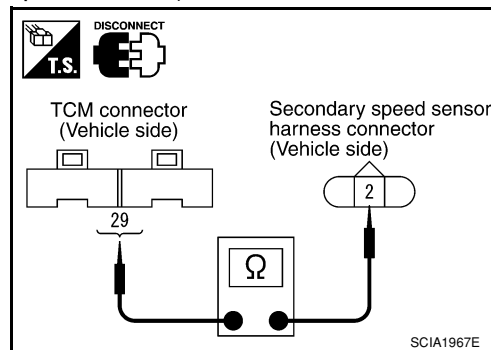

- If OK, check harness for short to ground and short to power.
- Reinstall any part removed.

OK or NG

OK >> GO TO 5.

NG >> Repair open circuit or short to ground or short to power in harness or connectors.

5. CHECK THE TCM SHORT

Replace same type TCM, perform self-diagnosis check. Erase self-diagnostic results and then drive the vehicle [more than 40 km/h (25 MPH)], perform self-diagnosis check. Refer to [CVT-80, "DTC Confirmation Procedure"](#).

Is "P0720 VEH SPD SEN/CIR AT" detected again?

YES >> Replace the transaxle assembly. Refer to [CVT-178, "Removal and Installation"](#).

NO >> Replace TCM. Refer to [CVT-8, "Service After Replacing TCM and Transaxle Assembly"](#).

6. CHECK HARNESS BETWEEN TCM AND OUTPUT SPEED SENSOR (SECONDARY SPEED SENSOR) (POWER)

- Turn ignition switch OFF.
- Disconnect TCM connector and output speed sensor (secondary speed sensor) harness connector.

DTC P0720 VEHICLE SPEED SENSOR CVT (SECONDARY SPEED SENSOR)

< SERVICE INFORMATION >

3. Check continuity between TCM connector terminals and output speed sensor (secondary speed sensor) harness connector terminal. Refer to [CVT-36. "Circuit Diagram"](#).

Item	Connector	Terminal	Continuity
TCM	E31	10	Yes
Output speed sensor (Secondary speed sensor)	F48	3	
TCM	E31	19	Yes
Output speed sensor (Secondary speed sensor)	F48	3	

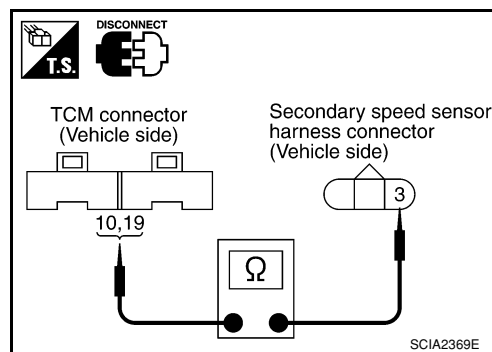

4. If OK, check harness for short to ground and short to power.
5. Reinstall any part removed.

OK or NG

- OK >> 10 A fuse (No. 49, located in the IPDM E/R) or ignition switch are malfunctioning.
- NG >> Repair open circuit or short to ground or short to power in harness or connectors.

7. CHECK HARNESS BETWEEN TCM AND OUTPUT SPEED SENSOR (SECONDARY SPEED SENSOR) (SENSOR GROUND)

1. Turn ignition switch OFF.
2. Disconnect TCM connector and output speed sensor (secondary speed sensor) harness connector.
3. Check continuity between TCM connector terminal and output speed sensor (secondary speed sensor) harness connector terminal.

Item	Connector	Terminal	Continuity
TCM	E32	42	Yes
Output speed sensor (Secondary speed sensor)	F48	1	

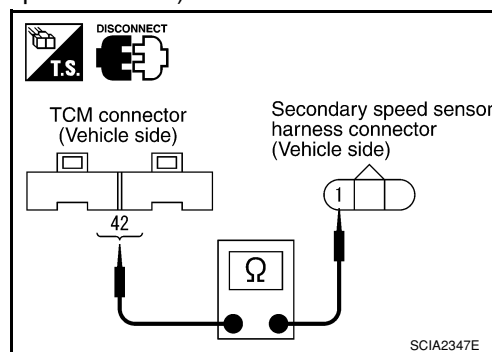

4. If OK, check harness for short to ground and short to power.
5. Reinstall any part removed.

OK or NG

- OK >> GO TO 8.
- NG >> Repair open circuit or short to ground or short to power in harness or connectors.

8. CHECK DTC

Perform [CVT-80. "DTC Confirmation Procedure"](#).

OK or NG

- OK >> **INSPECTION END**
- NG >> GO TO 9.

9. CHECK TCM

1. Check TCM input/output signals. Refer to [CVT-45. "TCM Terminal and Reference Value"](#).
2. If NG, re-check TCM pin terminals for damage or loose connection with harness connector.

OK or NG

- OK >> **INSPECTION END**
- NG >> Repair or replace damaged parts.

DTC P0725 ENGINE SPEED SIGNAL

< SERVICE INFORMATION >

DTC P0725 ENGINE SPEED SIGNAL

Description

INFOID:000000001703519

The engine speed signal is sent from the ECM to the TCM.

CONSULT-III Reference Value in Data Monitor Mode

INFOID:000000001703520

Remarks: Specification data are reference values.

Item name	Condition	Display value
ENG SPEED SIG	Engine running	Closely matches the tachometer reading.
ACC PEDAL OPEN	Released accelerator pedal - Fully depressed accelerator pedal	0.0/8 - 8.0/8

On Board Diagnosis Logic

INFOID:000000001703521

- This is not an OBD-II self-diagnostic item.
- Diagnostic trouble code "P0725 ENGINE SPEED SIG" with CONSULT-III is detected when TCM does not receive the engine speed signal (input by CAN communication) from ECM.

Possible Cause

INFOID:000000001703522

Harness or connectors
(The ECM to the TCM circuit is open or shorted.)

DTC Confirmation Procedure

INFOID:000000001703523

CAUTION:

Always drive vehicle at a safe speed.

NOTE:

If "DTC Confirmation Procedure" has been previously performed, always turn ignition switch OFF and wait at least 10 seconds before performing the next test.

After the repair, touch "ERASE" on "SELF-DIAG RESULTS" and then perform the following procedure to confirm the malfunction is eliminated.

Ⓜ WITH CONSULT-III

1. Turn ignition switch ON and select "DATA MONITOR" mode for "TRANSMISSION" with CONSULT-III.
2. Start engine and maintain the following conditions for at least 10 consecutive seconds.
PRI SPEED SEN: More than 1000 rpm
3. If DTC is detected, go to [CVT-85. "Diagnosis Procedure"](#).

Diagnosis Procedure

INFOID:000000001703524

1. CHECK DTC WITH ECM

Ⓜ With CONSULT-III

1. Turn ignition switch ON. (Do not start engine.)
2. Select "SELF-DIAG RESULTS" mode for "ENGINE" with CONSULT-III. Refer to [EC-109. "CONSULT-II Function \(ENGINE\)"](#).

OK or NG

- OK >> GO TO 2.
NG >> Check the DTC detected item. Refer to [EC-109. "CONSULT-II Function \(ENGINE\)"](#).

2. CHECK DTC WITH TCM

Ⓜ With CONSULT-III

1. Turn ignition switch ON. (Do not start engine.)
2. Select "SELF-DIAG RESULTS" mode for "TRANSMISSION" with CONSULT-III. Refer to [CVT-47. "CONSULT-III Function \(TRANSMISSION\)"](#).

OK or NG

- OK >> GO TO 3.
NG >> Check the DTC detected item. Refer to [CVT-47. "CONSULT-III Function \(TRANSMISSION\)"](#).

DTC P0725 ENGINE SPEED SIGNAL

< SERVICE INFORMATION >

- If DTC of CAN communication line is detected, go to [CVT-56](#).

3. CHECK INPUT SIGNALS

With CONSULT-III

1. Start engine.
2. Select "ECU INPUT SIGNALS" in "DATA MONITOR" mode for "TRANSMISSION" with CONSULT-III.
3. While monitoring "ENG SPEED SIG", check for engine speed change corresponding to "ACC PEDAL OPEN".

Item name	Condition	Display value
ENG SPEED SIG	Engine running	Closely matches the tachometer reading.
ACC PEDAL OPEN	Released accelerator pedal - Fully depressed accelerator pedal	0.0/8 - 8.0/8

OK or NG

- OK >> GO TO 4.
NG >> Check ignition signal circuit. Refer to [EC-531](#).

4. CHECK DTC

Perform [CVT-85. "DTC Confirmation Procedure"](#).

OK or NG

- OK >> **INSPECTION END**
NG >> GO TO 5.

5. CHECK TCM

1. Check TCM input/output signals. Refer to [CVT-45. "TCM Terminal and Reference Value"](#).
2. If NG, re-check TCM pin terminals for damage or loose connection with harness connector.

OK or NG

- OK >> **INSPECTION END**
NG >> Repair or replace damaged parts.

DTC P0730 BELT DAMAGE

< SERVICE INFORMATION >

DTC P0730 BELT DAMAGE

Description

INFOID:000000001703525

TCM selects the gear ratio using the engine load (throttle position), the primary pulley revolution speed, and the secondary pulley revolution speed as input signal. Then it changes the operating pressure of the primary pulley and the secondary pulley and changes the groove width of the pulley.

CONSULT-III Reference Value in Data Monitor Mode

INFOID:000000001703526

Remarks: Specification data are reference values.

Item name	Condition	Display value (Approx.)
GEAR RATIO	During driving	2.56 - 0.43

On Board Diagnosis Logic

INFOID:000000001703527

- This is not an OBD-II self-diagnostic item.
- TCM calculates the actual gear ratio with input speed sensor (primary speed sensor) and output speed sensor (secondary speed sensor).
- Diagnostic trouble code "P0730 BELT DAMG" with CONSULT-III is detected, when TCM receives an unexpected gear ratio signal.

Possible Cause

INFOID:000000001703528

Transaxle assembly

DTC Confirmation Procedure

INFOID:000000001703529

CAUTION:

Always drive vehicle at a safe speed.

NOTE:

If "DTC Confirmation Procedure" has been previously performed, always turn ignition switch OFF and wait at least 10 seconds before performing the next test.

After the repair, perform the following procedure to confirm the malfunction is eliminated.

Ⓟ WITH CONSULT-III

1. Turn ignition switch ON and select "DATA MONITOR" mode for "TRANSMISSION" with CONSULT-III.
2. Make sure that output voltage of CVT fluid temperature sensor is within the range below.
ATF TEMP SEN: 1.0 - 2.0 V
If out of range, drive the vehicle to decrease the voltage (warm up the fluid) or stop engine to increase the voltage (cool down the fluid)
3. Select "DATA MONITOR" mode for "TRANSMISSION" with CONSULT-III.
4. Start engine and maintain the following conditions for at least 30 consecutive seconds.
TEST START FROM 0 km/h (0 MPH)
CONSTANT ACCELERATION: Keep 30 sec or more
VEHICLE SPEED: 10 km/h (6 MPH) or more
ACC PEDAL OPEN: More than 1.0/8
RANGE: "D" position
ENG SPEED: 450 rpm or more
5. If DTC is detected, go to [CVT-87, "Diagnosis Procedure"](#).

Diagnosis Procedure

INFOID:000000001703530

1. CHECK DTC

Perform [CVT-87, "DTC Confirmation Procedure"](#).

Are any DTC displayed?

YES - 1>> DTC except for "P0730 BELT DAMG" is displayed: Go to Check the DTC detected item. Refer to [CVT-47, "CONSULT-III Function \(TRANSMISSION\)"](#).

YES - 2>> DTC for "P0730 BELT DAMG" is displayed: Replace the transaxle assembly. Refer to [CVT-178, "Removal and Installation"](#).

NO >> **INSPECTION END**

DTC P0740 TORQUE CONVERTER CLUTCH SOLENOID VALVE

< SERVICE INFORMATION >

DTC P0740 TORQUE CONVERTER CLUTCH SOLENOID VALVE

Description

INFOID:000000001703531

- The torque converter clutch solenoid valve is included in the control valve assembly.
- The torque converter clutch solenoid valve is activated by the TCM in response to signals sent from the vehicle speed and accelerator pedal position sensors. Lock-up piston operation will then be controlled.
- Lock-up operation, however, is prohibited when CVT fluid temperature is too low.
- When the accelerator pedal is depressed (less than 2.0/8) in lock-up condition, the engine speed should not change abruptly. If there is a big jump in engine speed, there is no lock-up.

CONSULT-III Reference Value in Data Monitor Mode

INFOID:000000001703532

Remarks: Specification data are reference values.

Item name	Condition	Display value (Approx.)
ISOLT1	Lock-up OFF	0.0 A
	Lock-up ON	0.7 A

On Board Diagnosis Logic

INFOID:000000001703533

- This is an OBD-II self-diagnostic item.
- Diagnostic trouble code "P0740 TCC SOLENOID/CIRC" with CONSULT-III is detected under the following conditions.
 - TCM detects an improper voltage drop when it tries to operate the solenoid valve.

Possible Cause

INFOID:000000001703534

- Torque converter clutch solenoid valve
- Harness or connectors
(Solenoid circuit is open or shorted.)

DTC Confirmation Procedure

INFOID:000000001703535

NOTE:

If "DTC Confirmation Procedure" has been previously performed, always turn ignition switch OFF and wait at least 10 seconds before performing the next test.

After the repair, touch "ERASE" on "SELF-DIAG RESULTS" and then perform the following procedure to confirm the malfunction is eliminated.

④ WITH CONSULT-III

1. Turn ignition switch ON. (Do not start engine.)
2. Select "DATA MONITOR" mode for "TRANSMISSION" with CONSULT-III and wait at least 10 consecutive seconds.
3. If DTC is detected, go to [CVT-90. "Diagnosis Procedure"](#).

④ WITH GST

Follow the procedure "WITH CONSULT-III".

DTC P0740 TORQUE CONVERTER CLUTCH SOLENOID VALVE

< SERVICE INFORMATION >

Wiring Diagram - CVT - TCV

INFOID:000000001703536

CVT-TCV-01

— : DETECTABLE LINE FOR DTC
 - - - : NON-DETECTABLE LINE FOR DTC

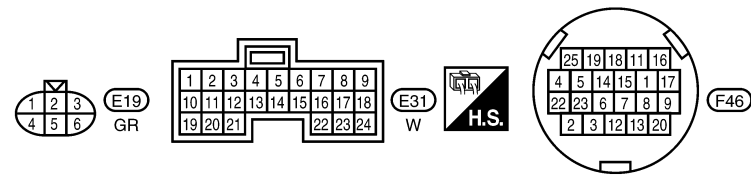
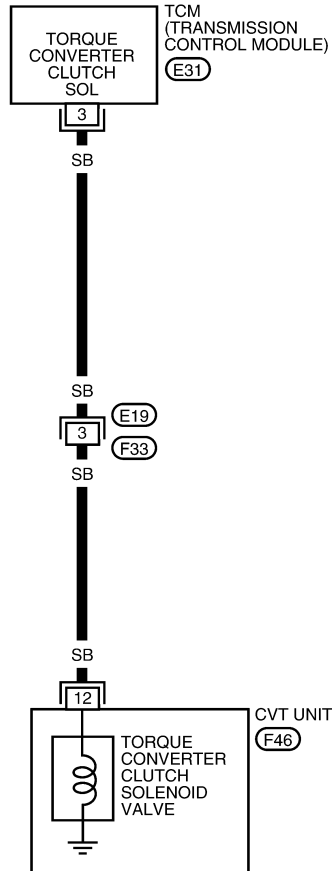

TCM TERMINALS AND REFERENCE VALUES

Refer to [CVT-45, "TCM Terminal and Reference Value"](#).

BCWA0674E

DTC P0740 TORQUE CONVERTER CLUTCH SOLENOID VALVE

< SERVICE INFORMATION >

Diagnosis Procedure

INFOID:000000001703537

1. CHECK INPUT SIGNAL

Ⓜ With CONSULT-III

1. Start engine.
2. Select "MAIN SIGNALS" in "DATA MONITOR" mode for "TRANSMISSION" with CONSULT-III.
3. Start vehicle and read out the value of "ISOLT1".

Item name	Condition	Display value (Approx.)
ISOLT1	Lock-up OFF	0.0 A
	Lock-up ON	0.7 A

ⓧ Without CONSULT-III

1. Start engine.
2. Check voltage between TCM connector terminal and ground.

Name	Connector	Terminal	Condition	Voltage (Approx.)	
Torque converter clutch solenoid valve	E31	3 - ground	When vehicle cruises in "D" position	Lock-up ON	6.0 V
			Lock-up OFF	1.0 V	

3. Turn ignition switch OFF.
4. Disconnect TCM connector.
5. Check if there is continuity between the connector terminal and ground.

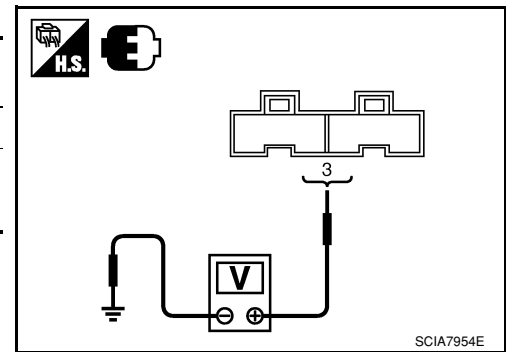

OK or NG

- OK >> GO TO 5.
NG >> GO TO 2.

2. CHECK TORQUE CONVERTER CLUTCH SOLENOID VALVE CIRCUIT

1. Turn ignition switch OFF.
2. Disconnect TCM connector.
3. Check resistance between TCM connector terminal and ground.

Solenoid valve	Connector	Terminal	Resistance (Approx.)
Torque converter clutch solenoid valve	E31	3 - Ground	3 - 9 Ω

OK or NG

- OK >> GO TO 5.
NG >> GO TO 3.

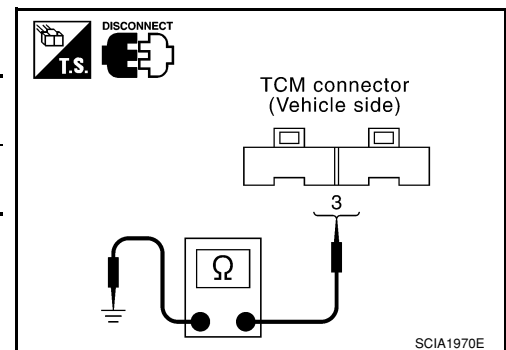

3. CHECK HARNESS BETWEEN TCM AND TORQUE CONVERTER CLUTCH SOLENOID VALVE

1. Turn ignition switch OFF.
2. Disconnect TCM connector and CVT unit harness connector.

DTC P0740 TORQUE CONVERTER CLUTCH SOLENOID VALVE

< SERVICE INFORMATION >

3. Check continuity between TCM connector terminal and CVT unit harness connector terminal.

Item	Connector	Terminal	Continuity
TCM	E31	3	Yes
CVT unit harness connector	F46	12	

4. If OK, check harness for short to ground and short to power.
5. If OK, check continuity between ground and CVT assembly.
6. Reinstall any part removed.

OK or NG

- OK >> GO TO 4.
- NG >> Repair or replace damaged parts.

4.CHECK VALVE RESISTANCE

1. Turn ignition switch OFF.
2. Disconnect CVT unit harness connector.
3. Check resistance between CVT unit harness connector terminal and ground.

Solenoid Valve	Connector	Terminal	Resistance (Approx.)
Torque converter clutch solenoid valve	F46	12 - Ground	3 - 9 Ω

OK or NG

- OK >> GO TO 5.
- NG >> Repair or replace damaged parts.

5.CHECK DTC

Perform [CVT-88. "DTC Confirmation Procedure"](#) .

OK or NG

- OK >> **INSPECTION END**
- NG >> GO TO 6.

6.CHECK TCM

1. Check TCM input/output signals. Refer to [CVT-45. "TCM Terminal and Reference Value"](#) .
2. If NG, re-check TCM pin terminals for damage or loose connection with harness connector.

OK or NG

- OK >> **INSPECTION END**
- NG >> Repair or replace damaged parts.

Component Inspection

INFOID:000000001703538

TORQUE CONVERTER CLUTCH SOLENOID VALVE

1. Turn ignition switch OFF.
2. Disconnect CVT unit harness connector.

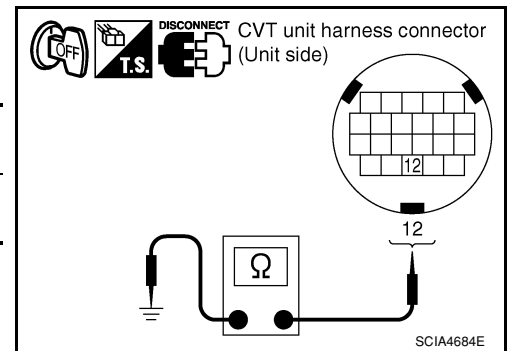
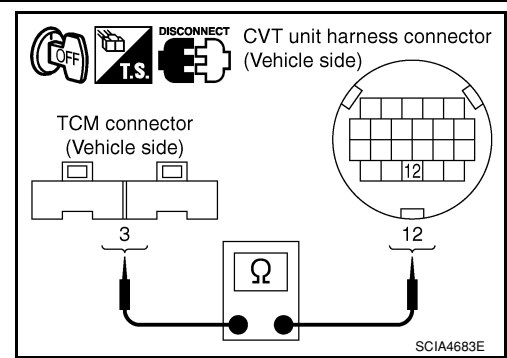

DTC P0740 TORQUE CONVERTER CLUTCH SOLENOID VALVE

< SERVICE INFORMATION >

3. Check resistance between CVT unit harness connector terminal and ground.

Solenoid Valve	Connector	Terminal	Resistance (Approx.)
Torque converter clutch solenoid valve	F46	12 - Ground	3 - 9 Ω

4. If NG, replace the transaxle assembly. Refer to [CVT-178](#), "[Removal and Installation](#)".

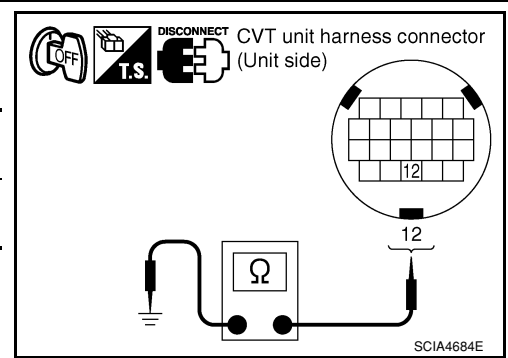

DTC P0744 A/T TCC S/V FUNCTION (LOCK-UP)

< SERVICE INFORMATION >

DTC P0744 A/T TCC S/V FUNCTION (LOCK-UP)

Description

INFOID:000000001703539

- The torque converter clutch solenoid valve is included in the control valve assembly.
- This malfunction is detected when the torque converter clutch does not lock-up as instructed by the TCM. This is not only caused by electrical malfunction (circuits open or shorted), but also by mechanical malfunction such as control valve sticking, improper solenoid valve operation, etc.

CONSULT-III Reference Value in Data Monitor Mode

INFOID:000000001703540

Remarks: Specification data are reference values.

Item name	Condition	Display value
ENG SPEED SIG	Engine running	Closely matches the tachometer reading.
PRI SPEED SEN	During driving (lock-up ON)	Approximately matches the engine speed.

On Board Diagnosis Logic

INFOID:000000001703541

- This is an OBD-II self-diagnostic item.
- Diagnostic trouble code “P0744 A/T TCC S/V FNCTN” with CONSULT-III is detected under the following conditions.
 - When CVT cannot perform lock-up even if electrical circuit is good.
 - When TCM compares difference value with slip revolution and detects an irregularity.

Possible Cause

INFOID:000000001703542

- Torque converter clutch solenoid valve
- Hydraulic control circuit

DTC Confirmation Procedure

INFOID:000000001703543

CAUTION:

Always drive vehicle at a safe speed.

NOTE:

If “DTC Confirmation Procedure” has been previously performed, always turn ignition switch OFF and wait at least 10 seconds before performing the next test.

After the repair, touch “ERASE” on “SELF-DIAG RESULTS” and then perform the following procedure to confirm the malfunction is eliminated.

Ⓜ WITH CONSULT-III

1. Turn ignition switch ON. (Do not start engine.)
2. Select “DATA MONITOR” mode for “TRANSMISSION” with CONSULT-III.
3. Start engine and maintain the following condition for at least 30 seconds.
ACC PEDAL OPEN: More than 1.0/8
RANGE: “D” position
[Vehicle speed: Constant speed of more than 40 km/h (25 MPH)]
4. If DTC is detected go to [CVT-93. "Diagnosis Procedure"](#).

Ⓜ WITH GST

Follow the procedure “WITH CONSULT-III”.

Diagnosis Procedure

INFOID:000000001703544

1. CHECK INPUT SIGNALS

Ⓜ With CONSULT-III

1. Start engine.
2. Select “ECU INPUT SIGNALS” in “DATA MONITOR” mode for “TRANSMISSION” with CONSULT-III.
3. Start vehicle.
4. Check if there is a great difference between “ENG SPEED SIG” and “PRI SPEED SEN”. (Lock-up ON.)

DTC P0744 A/T TCC S/V FUNCTION (LOCK-UP)

< SERVICE INFORMATION >

Item name	Condition	Display value
ENG SPEED SIG	Engine running	Closely matches the tachometer reading.
PRI SPEED SEN	During driving (lock-up ON)	Approximately matches the engine speed.

OK or NG

- OK >> GO TO 5.
NG >> GO TO 2.

2.CHECK LINE PRESSURE

Perform line pressure test. Refer to [CVT-36, "Inspections before Trouble Diagnosis"](#).

OK or NG

- OK >> GO TO 3.
NG >> Repair or replace damaged parts. Refer to [CVT-36, "Inspections before Trouble Diagnosis"](#).

3.DETECT MALFUNCTIONING ITEM

Check the following:

- Torque converter clutch solenoid valve. Refer to [CVT-91, "Component Inspection"](#).
- Lock-up select solenoid valve. Refer to [CVT-135, "Component Inspection"](#).

OK or NG

- OK >> GO TO 4.
NG >> Repair or replace damaged parts.

4.CHECK OUTPUT SPEED SENSOR (SECONDARY SPEED SENSOR) SYSTEM AND INPUT SPEED SENSOR (PRIMARY SPEED SENSOR) SYSTEM

Check output speed sensor (secondary speed sensor) system and input speed sensor (primary speed sensor) system. Refer to [CVT-80, CVT-76](#).

OK or NG

- OK >> GO TO 5.
NG >> Repair or replace damaged parts.

5.CHECK DTC

Perform [CVT-93, "DTC Confirmation Procedure"](#).

OK or NG

- OK >> **INSPECTION END**
NG >> GO TO 6.

6.CHECK TCM

1. Check TCM input/output signals. Refer to [CVT-45, "TCM Terminal and Reference Value"](#).
2. If NG, re-check TCM pin terminals for damage or loose connection with harness connector.

OK or NG

- OK >> **INSPECTION END**
NG >> 1. Repair or replace damaged parts.
2. Replace the transaxle assembly. Refer to [CVT-178, "Removal and Installation"](#).

DTC P0745 LINE PRESSURE SOLENOID VALVE

< SERVICE INFORMATION >

DTC P0745 LINE PRESSURE SOLENOID VALVE

Description

INFOID:000000001703545

- The pressure control solenoid valve A (line pressure solenoid valve) is included in the control valve assembly.
- The pressure control solenoid valve A (line pressure solenoid valve) regulates the oil pump discharge pressure to suit the driving condition in response to a signal sent from the TCM.

CONSULT-III Reference Value in Data Monitor Mode

INFOID:000000001703546

Remarks: Specification data are reference values.

Item name	Condition	Display value (Approx.)
ISOLT2	Release your foot from the accelerator pedal.	0.8 A
	Press the accelerator pedal all the way down.	0.0 A

On Board Diagnosis Logic

INFOID:000000001703547

- This is an OBD-II self-diagnostic item.
- Diagnostic trouble code "P0745 L/PRESS SOL/CIRC" with CONSULT-III is detected under the following conditions.
 - TCM detects an improper voltage drop when it tries to operate the solenoid valve.
 - When TCM compares target value with monitor value and detects an irregularity.

Possible Cause

INFOID:000000001703548

- Harness or connectors
(Solenoid circuit is open or shorted.)
- Pressure control solenoid valve A (Line pressure solenoid valve)

DTC Confirmation Procedure

INFOID:000000001703549

NOTE:

If "DTC Confirmation Procedure" has been previously performed, always turn ignition switch OFF and wait at least 10 seconds before performing the next test.

After the repair, perform the following procedure to confirm the malfunction is eliminated.

④ WITH CONSULT-III

1. Turn ignition switch ON and select "DATA MONITOR" mode for "TRANSMISSION" with CONSULT-III.
2. Start engine and wait at least 5 seconds.
3. If DTC is detected, go to [CVT-97. "Diagnosis Procedure"](#).

④ WITH GST

Follow the procedure "WITH CONSULT-III".

DTC P0745 LINE PRESSURE SOLENOID VALVE

< SERVICE INFORMATION >

Wiring Diagram - CVT - LPSV

INFOID:000000001703550

CVT-LPSV-01

: DETECTABLE LINE FOR DTC
 : NON-DETECTABLE LINE FOR DTC

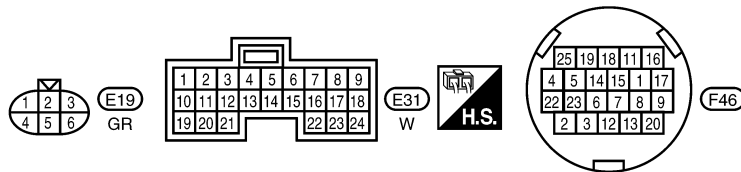
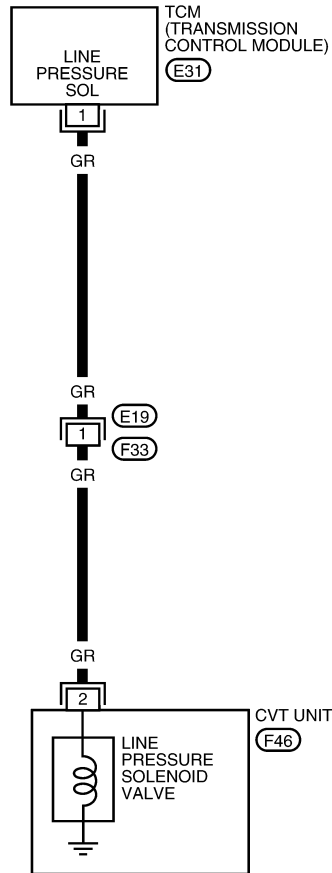

BCWA0675E

TCM TERMINALS AND REFERENCE VALUES
 Refer to [CVT-45, "TCM Terminal and Reference Value"](#).

DTC P0745 LINE PRESSURE SOLENOID VALVE

< SERVICE INFORMATION >

Diagnosis Procedure

INFOID:000000001703551

1. CHECK INPUT SIGNAL

④ With CONSULT-III

1. Start engine.
2. Select "MAIN SIGNALS" in "DATA MONITOR" mode for "TRANSMISSION" with CONSULT-III.
3. Read out the value of "ISOLT2".

Item name	Condition	Display value (Approx.)
ISOLT2	Release your foot from the accelerator pedal.	0.8 A
	Press the accelerator pedal all the way down.	0.0 A

⊗ Without CONSULT-III

1. Start engine.
2. Check voltage between TCM connector terminal and ground.

Name	Connector	Terminal	Condition	Voltage (Approx.)
Pressure control solenoid valve A (Line pressure solenoid valve)	E31	1 - ground	Release your foot from the accelerator pedal.	5.0 - 7.0 V
			Press the accelerator pedal all the way down.	1.0 - 3.0 V

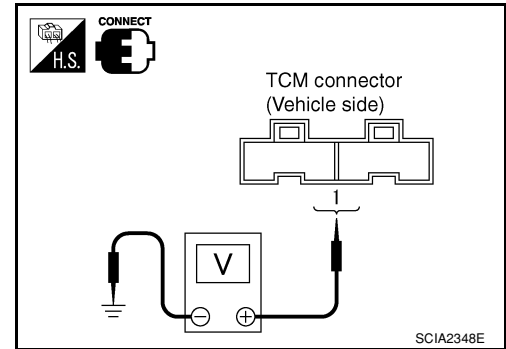

3. Turn ignition switch OFF.
4. Disconnect TCM connector.
5. Check if there is continuity between connector terminal and ground.

OK or NG

- OK >> GO TO 5.
NG >> GO TO 2.

2. CHECK PRESSURE CONTROL SOLENOID VALVE A (LINE PRESSURE SOLENOID VALVE) CIRCUIT

1. Turn ignition switch OFF.
2. Disconnect TCM connector.
3. Check resistance between TCM connector terminal and ground.

Solenoid valve	Connector	Terminal	Resistance (Approx.)
Pressure control solenoid valve A (Line pressure solenoid valve)	E31	1 - ground	3 - 9 Ω

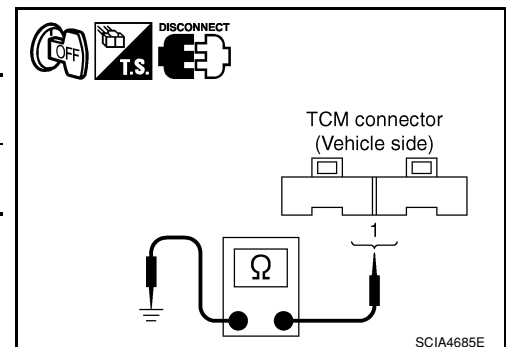

OK or NG

- OK >> GO TO 5.
NG >> GO TO 3.

3. CHECK VALVE RESISTANCE

1. Turn ignition switch OFF.
2. Disconnect CVT unit harness connector.

DTC P0745 LINE PRESSURE SOLENOID VALVE

< SERVICE INFORMATION >

3. Check resistance between CVT unit harness connector terminal and ground.

Solenoid valve	Connector	Terminal	Resistance (Approx.)
Pressure control solenoid valve A (Line pressure solenoid valve)	F46	2 - Ground	3 - 9 Ω

OK or NG

- OK >> GO TO 4.
 NG >> Replace the transaxle assembly. Refer to [CVT-178](#), "[Removal and Installation](#)".

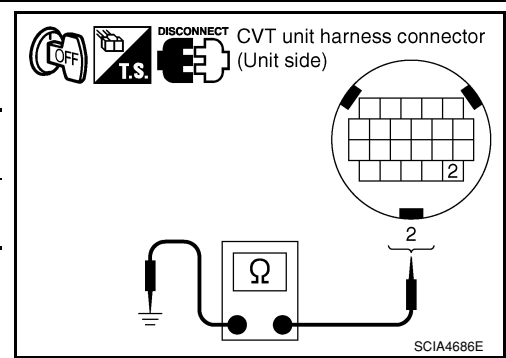

4. CHECK HARNESS BETWEEN TCM AND PRESSURE CONTROL SOLENOID VALVE A (LINE PRESSURE SOLENOID VALVE)

1. Turn ignition switch OFF.
2. Disconnect CVT unit harness connector and TCM connector.
3. Check continuity between TCM connector terminal and CVT unit harness connector terminal.

Item	Connector	Terminal	Continuity
TCM	E31	1	Yes
CVT unit harness connector	F46	2	

4. If OK, check harness for short to ground and short to power.
5. If OK, check continuity between ground and CVT assembly.
6. Reinstall any part removed.

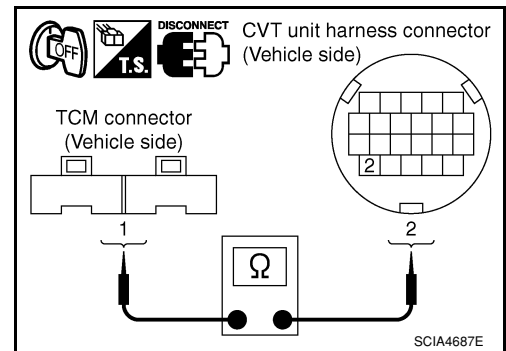

OK or NG

- OK >> GO TO 5.
 NG >> Repair open circuit or short to ground or short to power in harness or connectors.

5. CHECK DTC

Perform [CVT-95](#), "[DTC Confirmation Procedure](#)".

OK or NG

- OK >> **INSPECTION END**
 NG >> GO TO 6.

6. CHECK TCM

1. Check TCM terminals and reference values. Refer to [CVT-45](#), "[TCM Terminal and Reference Value](#)".
2. If NG, re-check TCM pin terminals for damage or loose connection with harness connector.

OK or NG

- OK >> **INSPECTION END**
 NG >> 1. Repair or replace damaged parts.
 2. Replace the transaxle assembly. Refer to [CVT-178](#), "[Removal and Installation](#)".

Component Inspection

INFOID:000000001703552

PRESSURE CONTROL SOLENOID VALVE A (LINE PRESSURE SOLENOID VALVE)

1. Turn ignition switch OFF.
2. Disconnect CVT unit harness connector.

DTC P0745 LINE PRESSURE SOLENOID VALVE

< SERVICE INFORMATION >

- Check resistance between CVT unit harness connector terminal and ground.

Solenoid valve	Connector	Terminal	Resistance (Approx.)
Pressure control solenoid valve A (Line pressure solenoid valve)	F46	2 - Ground	3 - 9 Ω

- If NG, replace the transaxle assembly. Refer to [CVT-178](#), "[Removal and Installation](#)".

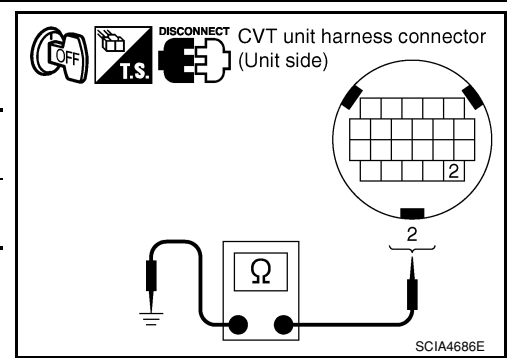

A
B
CVT
D
E
F
G
H
I
J
K
L
M
N
O
P

DTC P0746 PRESSURE CONTROL SOLENOID A PERFORMANCE (LINE PRESSURE SOLENOID VALVE)

< SERVICE INFORMATION >

DTC P0746 PRESSURE CONTROL SOLENOID A PERFORMANCE (LINE PRESSURE SOLENOID VALVE)

Description

INFOID:000000001703554

- The pressure control solenoid valve A (line pressure solenoid valve) is included in the control valve assembly.
- The pressure control solenoid valve A (line pressure solenoid valve) regulates the oil pump discharge pressure to suit the driving condition in response to a signal sent from the TCM.

CONSULT-III Reference Value in Data Monitor Mode

INFOID:000000001703554

Remarks: Specification data are reference values.

Item name	Condition	Display value (Approx.)
PRI PRESS	"N" position idle	0.4 MPa

On Board Diagnosis Logic

INFOID:000000001703555

- This is an OBD-II self-diagnostic item.
- Diagnostic trouble code "P0746 PRS CNT SOL/A FCTN" with CONSULT-III is detected under the following conditions.
 - Unexpected gear ratio was detected in the LOW side due to excessively low line pressure.

Possible Cause

INFOID:000000001703556

- Line pressure control system
- Output speed sensor (Secondary speed sensor)
- Input speed sensor (Primary speed sensor)

DTC Confirmation Procedure

INFOID:000000001703557

CAUTION:

Always drive vehicle at a safe speed.

NOTE:

If "DTC Confirmation Procedure" has been previously performed, always turn ignition switch OFF and wait at least 10 seconds before performing the next test.

After the repair, touch "ERASE" on "SELF-DIAG RESULTS" and then perform the following procedure to confirm the malfunction is eliminated.

Ⓜ WITH CONSULT-III

1. Turn ignition switch ON and select "DATA MONITOR" mode for "TRANSMISSION" with CONSULT-III.
2. Start engine and maintain the following conditions for at least 10 consecutive seconds. Test start from 0 km/h (0 MPH).
 - ATF TEMP SEN: 1.0 - 2.0 V**
 - ACC PEDAL OPEN: More than 1.0/8**
 - RANGE: "D" position**
 - VEHICLE SPEED: 10 km/h (6 MPH) More than**
 - Driving location: Driving the vehicle uphill (increased engine load) will help maintain the driving conditions required for this test.**
3. If DTC is detected, go to [CVT-100, "Diagnosis Procedure"](#).

Ⓜ WITH GST

Follow the procedure "WITH CONSULT-III".

Diagnosis Procedure

INFOID:000000001703558

1. CHECK INPUT SIGNAL

Ⓜ With CONSULT-III

1. Start engine.
2. Select "MAIN SIGNALS" in "DATA MONITOR" mode for "TRANSMISSION" with CONSULT-III.
3. Start vehicle and read out the value of "PRI PRESS".

DTC P0746 PRESSURE CONTROL SOLENOID A PERFORMANCE (LINE PRESSURE SOLENOID VALVE)

< SERVICE INFORMATION >

Item name	Condition	Display value (Approx.)
PRI PRESS	"N" position idle	0.4 MPa

⊗ Without CONSULT-III

- Start engine.
- Check voltage between TCM connector terminal and ground.

Name	Connector	Terminal	Condition	Voltage (Approx.)
Transmission fluid pressure sensor B (Primary pressure sensor)	E32	41 - Ground	"N" position idle	0.7 V

OK or NG

- OK >> GO TO 5.
 NG >> GO TO 2.

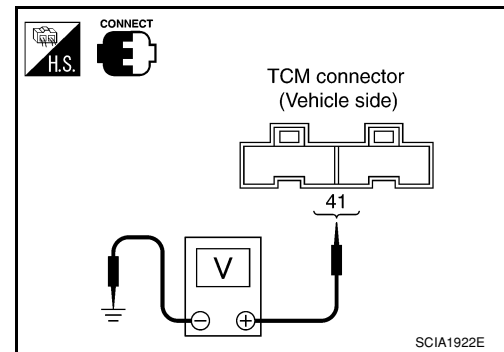

2. CHECK LINE PRESSURE

Perform line pressure test. Refer to [CVT-36, "Inspections before Trouble Diagnosis"](#).

OK or NG

- OK >> GO TO 3.
 NG >> Repair or replace damaged parts. Refer to [CVT-36, "Inspections before Trouble Diagnosis"](#).

3. DETECT MALFUNCTIONING ITEM

Check pressure control solenoid valve A (line pressure solenoid valve). Refer to [CVT-98, "Component Inspection"](#).

OK or NG

- OK >> GO TO 4.
 NG >> Repair or replace damaged parts.

4. CHECK OUTPUT SPEED SENSOR (SECONDARY SPEED SENSOR) SYSTEM AND INPUT SPEED SENSOR (PRIMARY SPEED SENSOR) SYSTEM

Check output speed sensor (secondary speed sensor) system and input speed sensor (primary speed sensor) system. Refer to [CVT-80, CVT-76](#).

OK or NG

- OK >> GO TO 5.
 NG >> Repair or replace damaged parts.

5. DETECT MALFUNCTIONING ITEM

Check the following:

- Power supply and ground circuit for TCM. Refer to [CVT-122, "Wiring Diagram - CVT - POWER"](#).
- The TCM pin terminals for damage or loose connection with harness connector.

OK or NG

- OK >> GO TO 6.
 NG >> Repair or replace damaged parts.

6. CHECK DTC

Perform [CVT-100, "DTC Confirmation Procedure"](#).

OK or NG

- OK >> **INSPECTION END**
 NG >> Replace the transaxle assembly or TCM. Refer to [CVT-178, "Removal and Installation"](#).

DTC P0776 PRESSURE CONTROL SOLENOID B PERFORMANCE (SEC PRESSURE SOLENOID VALVE)

< SERVICE INFORMATION >

DTC P0776 PRESSURE CONTROL SOLENOID B PERFORMANCE (SEC PRESSURE SOLENOID VALVE)

Description

INFOID:000000001703559

- The pressure control solenoid valve B (secondary pressure solenoid valve) is included in the control valve assembly.
- The pressure control solenoid valve B (secondary pressure solenoid valve) regulates the secondary pressure to suit the driving condition in response to a signal sent from the TCM.

CONSULT-III Reference Value in Data Monitor Mode

INFOID:000000001703560

Remarks: Specification data are reference values.

Item name	Condition	Display value (Approx.)
SEC PRESS	"N" position idle	0.8 MPa

On Board Diagnosis Logic

INFOID:000000001703561

- This is an OBD-II self-diagnostic item.
- Diagnostic trouble code "P0776 PRS CNT SOL/B FCTN" with CONSULT-III is detected when secondary pressure is too high or too low compared with the commanded value while driving.

Possible Cause

INFOID:000000001703562

- Harness or connectors
(Solenoid circuit is open or shorted.)
- Pressure control solenoid valve B (Secondary pressure solenoid valve system)
- Transmission fluid pressure sensor A (Secondary pressure sensor)
- Line pressure control system

DTC Confirmation Procedure

INFOID:000000001703563

CAUTION:

Always drive vehicle at a safe speed.

NOTE:

If "DTC Confirmation Procedure" has been previously performed, always turn ignition switch OFF and wait at least 10 seconds before performing the next test.

After the repair, perform the following procedure to confirm the malfunction is eliminated.

Ⓟ WITH CONSULT-III

1. Turn ignition switch ON and select "DATA MONITOR" mode for "TRANSMISSION" with CONSULT-III.
2. Start engine and maintain the following conditions for at least 30 consecutive seconds.
ATF TEMP SEN: 1.0 - 2.0 V
ACC PEDAL OPEN: More than 1.0/8
RANGE: "D" position
VEHICLE SPEED: 10 km/h (6 MPH) More than
Driving location: Driving the vehicle uphill (increased engine load) will help maintain the driving conditions required for this test.
3. If DTC is detected, go to [CVT-102. "Diagnosis Procedure"](#).

Ⓟ WITH GST

Follow the procedure "WITH CONSULT-III".

Diagnosis Procedure

INFOID:000000001703564

1. CHECK INPUT SIGNAL

Ⓟ With CONSULT-III

1. Start engine.
2. Select "MAIN SIGNALS" in "DATA MONITOR" mode for "TRANSMISSION" with CONSULT-III.
3. Start vehicle and read out the value of "SEC PRESS".

DTC P0776 PRESSURE CONTROL SOLENOID B PERFORMANCE (SEC PRESSURE SOLENOID VALVE)

< SERVICE INFORMATION >

Item name	Condition	Display value (Approx.)
SEC PRESS	"N" position idle	0.8 MPa

OK or NG

- OK >> GO TO 5.
- NG >> GO TO 2.

2.CHECK LINE PRESSURE

Perform line pressure test. Refer to [CVT-36. "Inspections before Trouble Diagnosis"](#).

OK or NG

- OK >> GO TO 3.
- NG >> Repair or replace damaged parts. Refer to [CVT-36. "Inspections before Trouble Diagnosis"](#).

3.DETECT MALFUNCTIONING ITEM

Check the following:

- Pressure control solenoid valve B (Secondary pressure solenoid valve). Refer to [CVT-107. "Component Inspection"](#).
- Pressure control solenoid valve A (Line pressure solenoid valve). Refer to [CVT-98. "Component Inspection"](#).

OK or NG

- OK >> GO TO 4.
- NG >> Repair or replace damaged parts.

4.CHECK TRANSMISSION FLUID PRESSURE SENSOR A (SECONDARY PRESSURE SENSOR) SYSTEM

Check transmission fluid pressure sensor A (secondary pressure sensor) system. Refer to [CVT-109](#).

OK or NG

- OK >> GO TO 5.
- NG >> Repair or replace damaged parts.

5.DETECT MALFUNCTIONING ITEM

Check the following:

- Power supply and ground circuit for TCM. Refer to [CVT-122. "Wiring Diagram - CVT - POWER"](#).
- The TCM pin terminals for damage or loose connection with harness connector.

OK or NG

- OK >> GO TO 6.
- NG >> Repair or replace damaged parts.

6.CHECK DTC

Perform [CVT-102. "DTC Confirmation Procedure"](#).

OK or NG

- OK >> **INSPECTION END**
- NG >> Replace the transaxle assembly. Refer to [CVT-178. "Removal and Installation"](#).

A
B
CVT
D
E
F
G
H
I
J
K
L
M
N
O
P

DTC P0778 PRESSURE CONTROL SOLENOID B ELECTRICAL (SEC PRESSURE SOLENOID VALVE)

< SERVICE INFORMATION >

DTC P0778 PRESSURE CONTROL SOLENOID B ELECTRICAL (SEC PRESSURE SOLENOID VALVE)

Description

INFOID:000000001703565

- The pressure control solenoid valve B (secondary pressure solenoid valve) is included in the control valve assembly.
- The pressure control solenoid valve B (secondary pressure solenoid valve) regulates the oil pump discharge pressure to suit the driving condition in response to a signal sent from the TCM.

CONSULT-III Reference Value in Data Monitor Mode

INFOID:000000001703566

Remarks: Specification data are reference values.

Item name	Condition	Display value (Approx.)
ISOLT3	Secondary pressure low - Secondary pressure high	0.8 - 0.0 A
SOLMON3	"N" position idle	0.6 - 0.7 A
	When stalled	0.4 - 0.6 A

On Board Diagnosis Logic

INFOID:000000001703567

- This is an OBD-II self-diagnostic item.
- Diagnostic trouble code "P0778 PRS CNT SOL/B CIRC" with CONSULT-III is detected under the following conditions.
 - TCM detects an improper voltage drop when it tries to operate the solenoid valve.
 - When TCM compares target value with monitor value and detects an irregularity.

Possible Cause

INFOID:000000001703568

- Harness or connectors
(Solenoid circuit is open or shorted.)
- Pressure control solenoid valve B (Secondary pressure solenoid valve)

DTC Confirmation Procedure

INFOID:000000001703569

NOTE:

If "DTC Confirmation Procedure" has been previously performed, always turn ignition switch OFF and wait at least 10 seconds before performing the next test.

After the repair, perform the following procedure to confirm the malfunction is eliminated.

WITH CONSULT-III

1. Turn ignition switch ON.
2. Select "DATA MONITOR" mode for "TRANSMISSION" with CONSULT-III.
3. Start engine and wait at least 5 seconds.
4. If DTC is detected, go to [CVT-106. "Diagnosis Procedure"](#) .

WITH GST

Follow the procedure "WITH CONSULT-III".

DTC P0778 PRESSURE CONTROL SOLENOID B ELECTRICAL (SEC PRES- SURE SOLENOID VALVE)

< SERVICE INFORMATION >

Wiring Diagram - CVT - SECPSV

INFOID:000000001703570

CVT-SECPSV-01

— : DETECTABLE LINE FOR DTC
 - - - : NON-DETECTABLE LINE FOR DTC

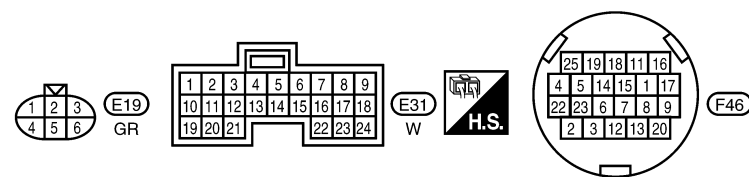
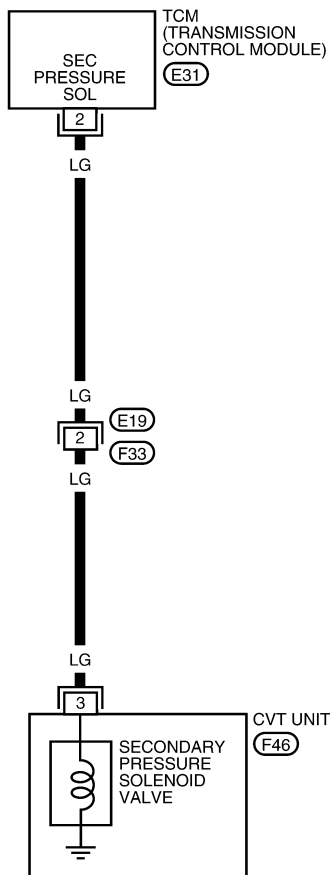

TCM TERMINALS AND REFERENCE VALUES
 Refer to [CVT-45, "TCM Terminal and Reference Value"](#).

BCWA0676E

DTC P0778 PRESSURE CONTROL SOLENOID B ELECTRICAL (SEC PRES- SURE SOLENOID VALVE)

< SERVICE INFORMATION >

Diagnosis Procedure

INFOID:000000001703571

1. CHECK INPUT SIGNAL

④ With CONSULT-III

1. Start engine.
2. Select "MAIN SIGNALS" in "DATA MONITOR" mode for "TRANSMISSION" with CONSULT-III.
3. Read out the value of "ISOLT3".

Item name	Condition	Display value (Approx.)
ISOLT3	Secondary pressure low - Secondary pressure high	0.8 - 0.0 A

⊗ Without CONSULT-III

1. Start engine.
2. Check voltage between TCM connector terminal and ground.

Name	Connector	Terminal	Condition	Voltage (Approx.)
Pressure control solenoid valve B (Secondary pressure solenoid valve)	E31	2 - ground	Release your foot from the accelerator pedal.	5.0 - 7.0 V
			Press the accelerator pedal all the way down.	3.0 - 4.0 V

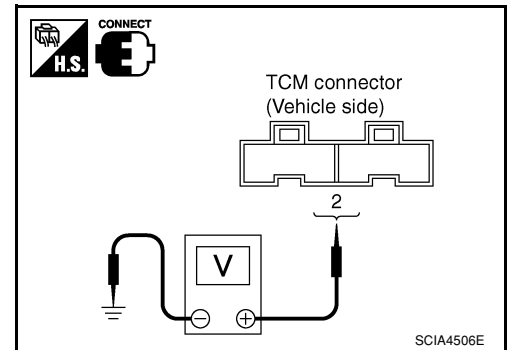

3. Turn ignition switch OFF.
4. Disconnect TCM connector.
5. Check if there is continuity between connector terminal and ground.

OK or NG

- OK >> GO TO 5.
NG >> GO TO 2.

2. CHECK PRESSURE CONTROL SOLENOID VALVE B (SECONDARY PRESSURE SOLENOID VALVE) CIRCUIT

1. Turn ignition switch OFF.
2. Disconnect TCM connector.
3. Check resistance between TCM connector terminal and ground.

Solenoid valve	Connector	Terminal	Resistance (Approx.)
Pressure control solenoid valve B (Secondary pressure solenoid valve)	E31	2 - Ground	3 - 9 Ω

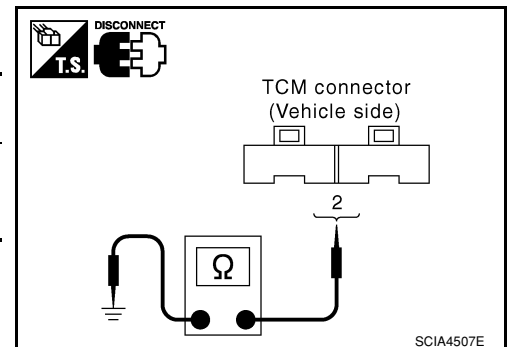

OK or NG

- OK >> GO TO 5.
NG >> GO TO 3.

3. CHECK VALVE RESISTANCE

1. Turn ignition switch OFF.
2. Disconnect CVT unit harness connector.

DTC P0778 PRESSURE CONTROL SOLENOID B ELECTRICAL (SEC PRESSURE SOLENOID VALVE)

< SERVICE INFORMATION >

3. Check resistance between CVT unit harness connector terminal and ground.

Solenoid valve	Connector	Terminal	Resistance (Approx.)
Pressure control solenoid valve B (Secondary pressure solenoid valve)	F46	3 - Ground	3 - 9 Ω

OK or NG

- OK >> GO TO 4.
- NG >> Repair or replace damaged parts.

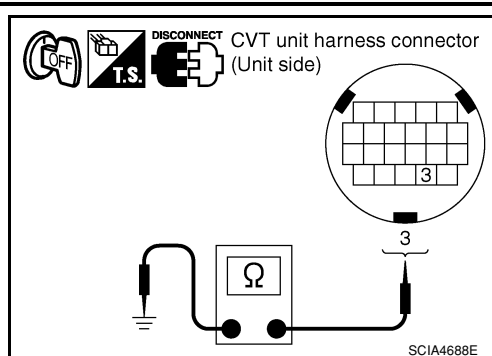

4. CHECK HARNESS BETWEEN TCM AND PRESSURE CONTROL SOLENOID VALVE B (SECONDARY PRESSURE SOLENOID VALVE)

1. Turn ignition switch OFF.
2. Disconnect TCM connector and CVT unit harness connector.
3. Check continuity between TCM connector terminal and CVT unit harness connector terminal.

Item	Connector	Terminal	Continuity
TCM connector	E31	2	Yes
CVT unit harness connector	F46	3	

4. If OK, check harness for short to ground and short to power.
5. Reinstall any part removed.

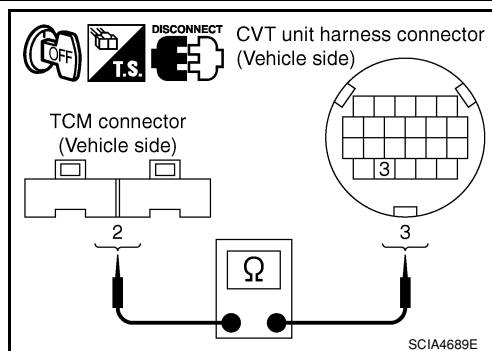

OK or NG

- OK >> GO TO 5.
- NG >> Repair or replace damaged parts.

5. CHECK DTC

Perform [CVT-104. "DTC Confirmation Procedure"](#) .

OK or NG

- OK >> **INSPECTION END**
- NG >> GO TO 6.

6. CHECK TCM

1. Check TCM input/output signals. Refer to [CVT-45. "TCM Terminal and Reference Value"](#) .
2. If NG, re-check TCM pin terminals for damage or loose connection with harness connector.

OK or NG

- OK >> **INSPECTION END**
- NG >> 1. Repair or replace damaged parts.
- 2. Replace the transaxle assembly. Refer to [CVT-178. "Removal and Installation"](#) .

Component Inspection

INFOID:000000001703572

PRESSURE CONTROL SOLENOID VALVE B (SECONDARY PRESSURE SOLENOID VALVE)

1. Turn ignition switch OFF.
2. Disconnect CVT unit harness connector.

DTC P0778 PRESSURE CONTROL SOLENOID B ELECTRICAL (SEC PRES- SURE SOLENOID VALVE)

< SERVICE INFORMATION >

3. Check resistance between CVT unit harness connector terminal and ground.

Solenoid Valve	Connector	Terminal	Resistance (Approx.)
Pressure control solenoid valve B (Secondary pressure solenoid valve)	F46	3 - Ground	3 - 9 Ω

4. If NG, replace the transaxle assembly. Refer to [CVT-178](#). "[Removal and Installation](#)".

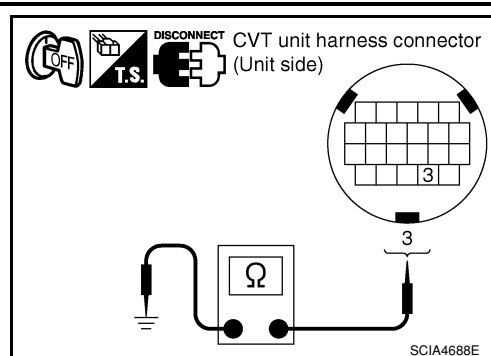

DTC P0840 TRANSMISSION FLUID PRESSURE SENSOR A CIRCUIT (SEC PRESSURE SENSOR)

< SERVICE INFORMATION >

DTC P0840 TRANSMISSION FLUID PRESSURE SENSOR A CIRCUIT (SEC PRESSURE SENSOR)

Description

INFOID:000000001703573

- The transmission fluid pressure sensor A (secondary pressure sensor) is included in the control valve assembly.
- The transmission fluid pressure sensor A (secondary pressure sensor) detects secondary pressure of CVT and sends TCM the signal.

CONSULT-III Reference Value in Data Monitor Mode

INFOID:000000001703574

Remarks: Specification data are reference values.

Item name	Condition	Display value (Approx.)
SEC HYDR SEN	"N" position idle	1.0 V
SEC PRESS		0.8 MPa

On Board Diagnosis Logic

INFOID:000000001703575

- This is an OBD-II self-diagnostic item.
- Diagnostic trouble code "P0840 TR PRS SENS/A CIRC" with CONSULT-III is detected when TCM detects an improper voltage drop when it receives the sensor signal.

Possible Cause

INFOID:000000001703576

- Transmission fluid pressure sensor A (Secondary pressure sensor)
- Harness or connectors
(Switch circuit is open or shorted.)

DTC Confirmation Procedure

INFOID:000000001703577

NOTE:

If "DTC Confirmation Procedure" has been previously performed, always turn ignition switch OFF and wait at least 10 seconds before performing the next test.

After the repair, perform the following procedure to confirm the malfunction is eliminated.

Ⓟ WITH CONSULT-III

1. Turn ignition switch ON and select "DATA MONITOR" mode for "TRANSMISSION" with CONSULT-III.
2. Make sure that output voltage of line temperature sensor is within the range below.
ATF TEMP SEN: 1.0 - 2.0 V
If out of range, drive the vehicle to decrease the voltage (warm up the fluid) or stop engine to increase the voltage (cool down the fluid)
3. Start engine and wait for at least 5 consecutive seconds.
4. If DTC is detected, go to [CVT-111, "Diagnosis Procedure"](#).

Ⓢ WITH GST

Follow the procedure "WITH CONSULT-III".

DTC P0840 TRANSMISSION FLUID PRESSURE SENSOR A CIRCUIT (SEC PRESSURE SENSOR)

< SERVICE INFORMATION >

Wiring Diagram - CVT - SECPS

INFOID:000000001703578

CVT-SECPS-01

— : DETECTABLE LINE FOR DTC
 - - - : NON-DETECTABLE LINE FOR DTC

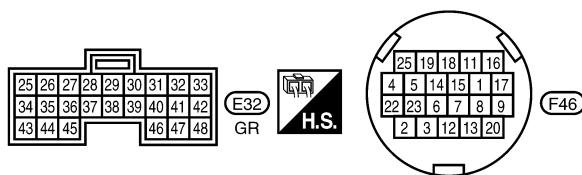
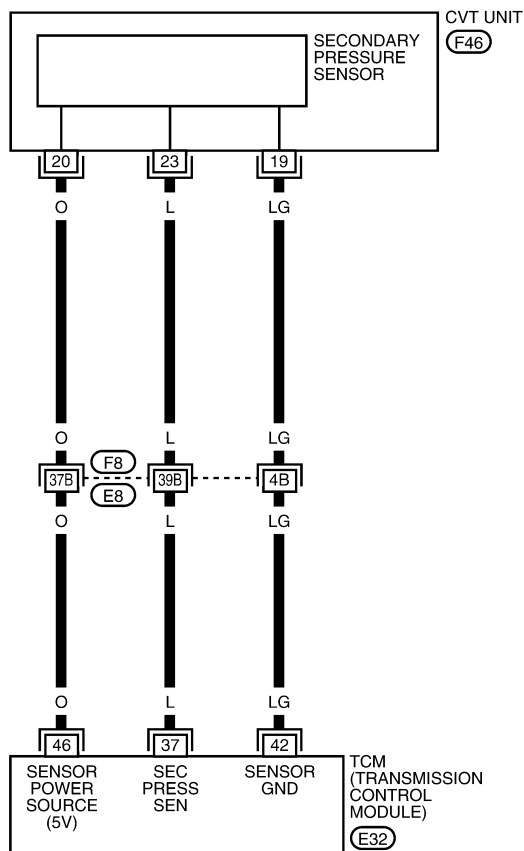

REFER TO THE FOLLOWING.

F8 - SUPER MULTIPLE JUNCTION (SMJ)

BCWA0677E

TCM TERMINALS AND REFERENCE VALUES

Refer to [CVT-45, "TCM Terminal and Reference Value"](#).

DTC P0840 TRANSMISSION FLUID PRESSURE SENSOR A CIRCUIT (SEC PRESSURE SENSOR)

< SERVICE INFORMATION >

Diagnosis Procedure

INFOID:000000001703579

1. CHECK INPUT SIGNAL

With CONSULT-III

1. Start engine.
2. Select "ECU INPUT SIGNALS" in "DATA MONITOR" mode for "TRANSMISSION" with CONSULT-III.
3. Start vehicle and read out the value of "SEC HYDR SEN".

Item name	Condition	Display value (Approx.)
SEC HYDR SEN	"N" position idle	1.0 V

Without CONSULT-III

1. Start engine.
2. Check voltage between TCM connector terminal and ground.

Name	Connector	Terminal	Condition	Voltage (Approx.)
Transmission fluid pressure sensor A (Secondary pressure sensor)	E32	37 - Ground	"N" position idle	1.0 V

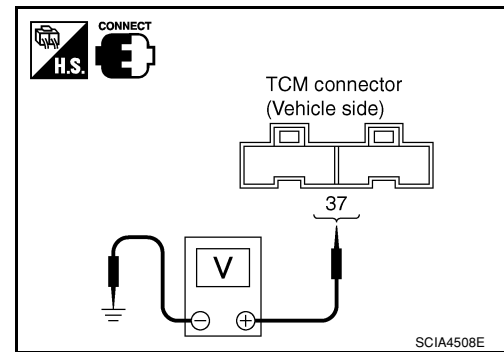

OK or NG

- OK >> GO TO 5.
 NG >> GO TO 2.

2. CHECK SENSOR POWER AND SENSOR GROUND

1. Turn ignition switch ON. (Do not start engine)
2. Check voltage between TCM connector terminals.

Item	Connector	Terminal	Data (Approx.)
TCM connector	E32	46 - 42	5.0 V

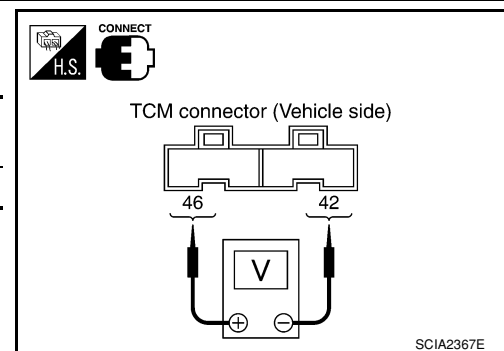

OK or NG

- OK >> GO TO 4.
 NG >> GO TO 3.

3. CHECK HARNESS BETWEEN TCM AND CVT UNIT HARNESS CONNECTOR (SENSOR POWER AND SENSOR GROUND)

1. Turn ignition switch OFF.
2. Disconnect TCM connector and CVT unit harness connector.
3. Check continuity between TCM connector terminals and CVT unit harness connector terminals.

Item	Connector	Terminal	Continuity
TCM	E32	42	Yes
CVT unit harness connector	F46	19	
TCM	E32	46	Yes
CVT unit harness connector	F46	20	

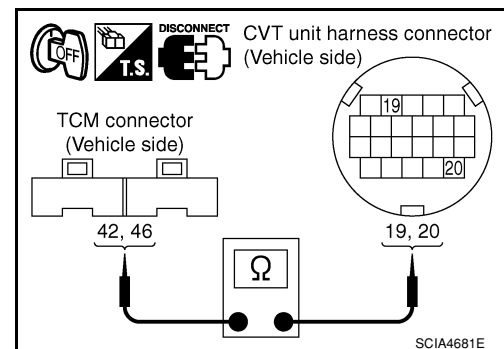

4. If OK, check harness for short to ground and short to power.
5. Reinstall any part removed.

OK or NG

A

B

CVT

D

E

F

G

H

I

J

K

L

M

N

O

P

DTC P0840 TRANSMISSION FLUID PRESSURE SENSOR A CIRCUIT (SEC PRESSURE SENSOR)

< SERVICE INFORMATION >

- OK >> Replace TCM. Refer to [CVT-8. "Service After Replacing TCM and Transaxle Assembly"](#).
- NG >> Repair open circuit or short to ground or short to power in harness or connectors.

4. CHECK HARNESS BETWEEN TCM AND TRANSMISSION FLUID PRESSURE SENSOR A (SECONDARY PRESSURE SENSOR)

1. Turn ignition switch OFF.
2. Disconnect TCM connector and CVT unit harness connector.
3. Check continuity between TCM connector terminal and CVT unit harness connector terminal.

Item	Connector	Terminal	Continuity
TCM	E32	37	Yes
CVT unit harness connector	F46	23	

4. If OK, check harness for short to ground and short to power.
5. Reinstall any part removed.

OK or NG

- OK >> GO TO 5.
- NG >> Repair open circuit or short to ground or short to power in harness or connectors.

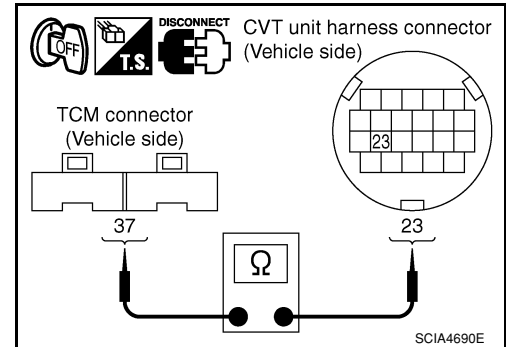

5. CHECK DTC

Perform [CVT-109. "DTC Confirmation Procedure"](#).

OK or NG

- OK >> **INSPECTION END**
- NG >> GO TO 6.

6. CHECK TCM

1. Check TCM input/output signals. Refer to [CVT-45. "TCM Terminal and Reference Value"](#).
2. If NG, re-check TCM pin terminals for damage or loose connection with harness connector.

OK or NG

- OK >> Replace the transaxle assembly. Refer to [CVT-178. "Removal and Installation"](#).
- NG >> Repair or replace damaged parts.

DTC P0841 PRESSURE SENSOR FUNCTION

< SERVICE INFORMATION >

DTC P0841 PRESSURE SENSOR FUNCTION

Description

INFOID:000000001703580

Using the engine load (throttle position), the primary pulley revolution speed, and the secondary pulley revolution speed as input signal, TCM changes the operating pressure of the primary pulley and the secondary pulley and changes the groove width of the pulley to control the gear ratio.

CONSULT-III Reference Value in Data Monitor Mode

INFOID:000000001703581

Remarks: Specification data are reference values.

Item name	Condition	Display value (Approx.)
PRI HYDR SEN	"N" position idle	0.7 V
SEC HYDR SEN		1.0 V

On Board Diagnosis Logic

INFOID:000000001703582

- This is not an OBD-II self-diagnostic item.
- Diagnostic trouble code "P0841 PRESS SEN/FNCTN" with CONSULT-III is detected when correlation between the values of the secondary pressure sensor and the primary pressure sensor is out of specification.

Possible Cause

INFOID:000000001703583

- Transmission fluid pressure sensor A (Secondary pressure sensor)
- Transmission fluid pressure sensor B (Primary pressure sensor)
- Harness or connectors
(Sensor circuit is open or shorted.)

DTC Confirmation Procedure

INFOID:000000001703584

CAUTION:

Always drive vehicle at a safe speed.

NOTE:

If "DTC Confirmation Procedure" has been previously performed, always turn ignition switch OFF and wait at least 10 seconds before performing the next test.

After the repair, perform the following procedure to confirm the malfunction is eliminated.

④ WITH CONSULT-III

1. Turn ignition switch ON and select "DATA MONITOR" mode for "TRANSMISSION" with CONSULT-III.
2. Start engine and maintain the following conditions for at least 12 consecutive seconds.
VEHICLE SPEED: 40 km/h (25 MPH) More than
RANGE: "D" position
3. If DTC is detected, go to [CVT-113. "Diagnosis Procedure"](#).

Diagnosis Procedure

INFOID:000000001703585

1. CHECK CAN COMMUNICATION LINE

Perform the self-diagnosis. Refer to [CVT-47. "CONSULT-III Function \(TRANSMISSION\)"](#).

Is any malfunction of the "U1000 CAN COMM CIRCUIT" indicated?

YES >> Check CAN communication line. Refer to [CVT-56](#).

NO >> GO TO 2.

2. CHECK INPUT SIGNALS

④ With CONSULT-III

1. Start engine.
2. Select "ECU INPUT SIGNALS" in "DATA MONITOR" mode for "TRANSMISSION" with CONSULT-III.
3. Start vehicle and read out the value of "SEC HYDR SEN" and "PRI HYDR SEN".

DTC P0841 PRESSURE SENSOR FUNCTION

< SERVICE INFORMATION >

Item name	Condition	Display value (Approx.)
PRI HYDR SEN	"N" position idle	0.7 V
SEC HYDR SEN		1.0 V

⊗ Without CONSULT-III

1. Start engine.
2. Check voltage between TCM connector terminals and ground.

Name	Connector	Terminal	Condition	Voltage (Approx.)
Transmission fluid pressure sensor B (Primary pressure sensor)	E32	41 - Ground	"N" position idle	0.7 V
Transmission fluid pressure sensor A (Secondary pressure sensor)		37 - Ground		1.0 V

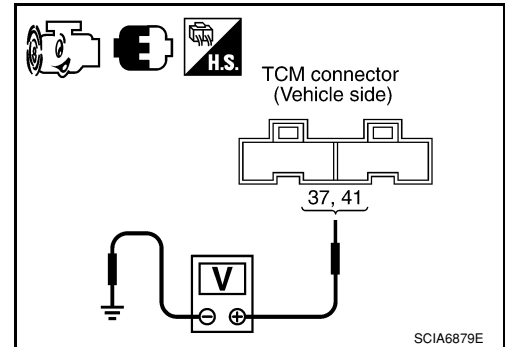

OK or NG

- OK >> GO TO 6.
 NG >> GO TO 3.

3. CHECK LINE PRESSURE

Perform line pressure test. Refer to [CVT-36. "Inspections before Trouble Diagnosis"](#).

OK or NG

- OK >> GO TO 4.
 NG >> Repair or replace damaged parts. Refer to [CVT-36. "Inspections before Trouble Diagnosis"](#).

4. CHECK TRANSMISSION FLUID PRESSURE SENSOR A (SECONDARY PRESSURE SENSOR) SYSTEM AND TRANSMISSION FLUID PRESSURE SENSOR B (PRIMARY PRESSURE SENSOR) SYSTEM

Check transmission fluid pressure sensor A (secondary pressure sensor) system and transmission fluid pressure sensor B (primary pressure sensor) system. Refer to [CVT-109](#), [CVT-115](#).

OK or NG

- OK >> GO TO 5.
 NG >> Repair or replace damaged parts.

5. DETECT MALFUNCTIONING ITEM

Check the following:

- Pressure control solenoid valve A (Line pressure solenoid valve). Refer to [CVT-98. "Component Inspection"](#).
- Pressure control solenoid valve B (Secondary pressure solenoid valve). Refer to [CVT-107. "Component Inspection"](#).
- Step motor. Refer to [CVT-140. "Component Inspection"](#).

OK or NG6

- OK >> GO TO 6.
 NG >> Repair or replace damaged parts.

6. CHECK DTC

Perform [CVT-113. "DTC Confirmation Procedure"](#).

OK or NG

- OK >> **INSPECTION END**
 NG >> Replace TCM or transaxle assembly. Refer to [CVT-178. "Removal and Installation"](#).

DTC P0845 TRANSMISSION FLUID PRESSURE SENSOR B CIRCUIT (PRI PRESSURE SENSOR)

< SERVICE INFORMATION >

DTC P0845 TRANSMISSION FLUID PRESSURE SENSOR B CIRCUIT (PRI PRESSURE SENSOR)

Description

INFOID:000000001703586

- The transmission fluid pressure sensor B (primary pressure sensor) is included in the control valve assembly.
- The transmission fluid pressure sensor B (primary pressure sensor) detects primary pressure of CVT and sends TCM the signal.

CONSULT-III Reference Value in Data Monitor Mode

INFOID:000000001703587

Remarks: Specification data are reference values.

Item name	Condition	Display value (Approx.)
PRI HYDR SEN	"N" position idle	0.7 V

On Board Diagnosis Logic

INFOID:000000001703588

- This is an OBD-II self-diagnostic item.
- Diagnostic trouble code "P0845 TR PRS SENS/B CIRC" with CONSULT-III is detected under the following conditions.
 - When TCM detects an improper voltage drop when it receives the sensor signal.
 - When TCM compares target value with monitor value and detects an irregularity.

Possible Cause

INFOID:000000001703589

- Transmission fluid pressure sensor B (Primary pressure sensor)
- Harness or connectors
(Sensor circuit is open or shorted.)

DTC Confirmation Procedure

INFOID:000000001703590

NOTE:

If "DTC Confirmation Procedure" has been previously performed, always turn ignition switch OFF and wait at least 10 seconds before performing the next test.

After the repair, perform the following procedure to confirm the malfunction is eliminated.

④ WITH CONSULT-III

1. Turn ignition switch ON and select "DATA MONITOR" mode for "TRANSMISSION" with CONSULT-III.
2. Make sure that output voltage of line temperature sensor is within the range below.
ATF TEMP SEN: 1.0 - 2.0 V
If out of range, drive the vehicle to decrease the voltage (warm up the fluid) or stop engine to increase the voltage (cool down the fluid)
3. Start engine and wait for at least 5 consecutive seconds.
4. If DTC is detected, go to [CVT-117, "Diagnosis Procedure"](#).

④ WITH GST

Follow the procedure "WITH CONSULT-III".

DTC P0845 TRANSMISSION FLUID PRESSURE SENSOR B CIRCUIT (PRI PRESSURE SENSOR)

< SERVICE INFORMATION >

Wiring Diagram - CVT - PRIPS

INFOID:000000001703591

CVT-PRIPS-01

: DETECTABLE LINE FOR DTC
 : NON-DETECTABLE LINE FOR DTC

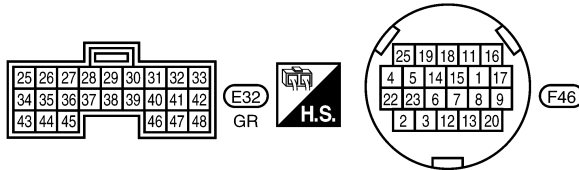
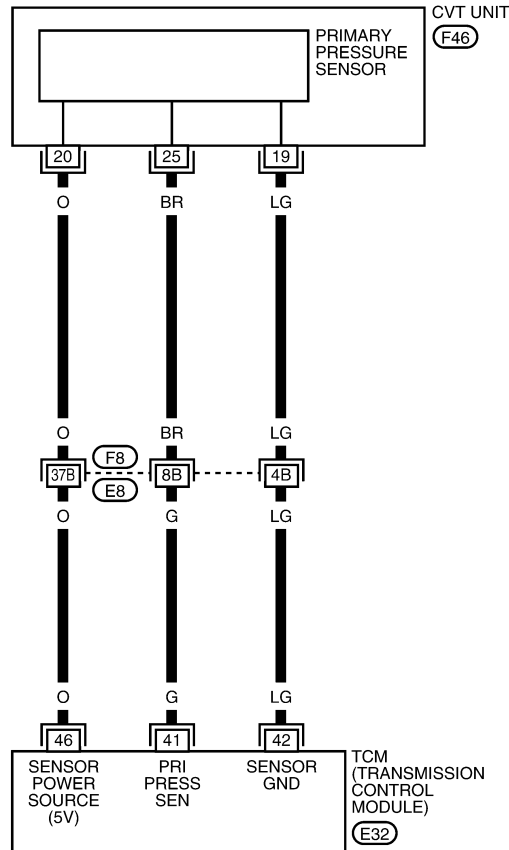

REFER TO THE FOLLOWING.

(F8) - SUPER MULTIPLE JUNCTION (SMJ)

BCWA0678E

CM TERMINALS AND REFERENCE VALUES

Refer to [CVT-45, "TCM Terminal and Reference Value"](#).

DTC P0845 TRANSMISSION FLUID PRESSURE SENSOR B CIRCUIT (PRI PRESSURE SENSOR)

< SERVICE INFORMATION >

Diagnosis Procedure

INFOID:000000001703592

1. CHECK INPUT SIGNAL

Ⓜ With CONSULT-III

1. Start engine.
2. Select "ECU INPUT SIGNALS" in "DATA MONITOR" mode for "TRANSMISSION" with CONSULT-III.
3. Start vehicle and read out the value of "PRI HYDR SEN".

Item name	Condition	Display value (Approx.)
PRI HYDR SEN	"N" position idle	0.7 V

⊗ Without CONSULT-III

1. Start engine.
2. Check voltage between TCM connector terminal and ground.

Name	Connector	Terminal	Condition	Voltage (Approx.)
Transmission fluid pressure sensor B (Primary pressure sensor)	E32	41 - Ground	"N" position idle	0.7 V

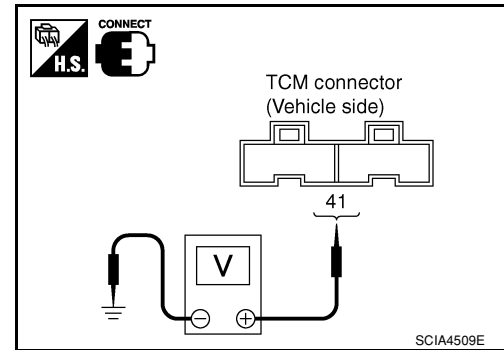

OK or NG

- OK >> GO TO 5.
 NG >> GO TO 2.

2. CHECK SENSOR POWER AND SENSOR GROUND

1. Turn ignition switch ON. (Do not start engine)
2. Check voltage between TCM connector terminals.

Item	Connector	Terminal	Data (Approx.)
TCM connector	E32	46 - 42	5.0 V

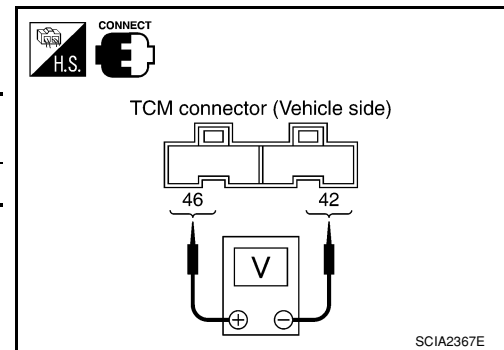

OK or NG

- OK >> GO TO 4.
 NG >> GO TO 3.

3. CHECK HARNESS BETWEEN TCM AND CVT UNIT HARNESS CONNECTOR (SENSOR POWER AND SENSOR GROUND)

1. Turn ignition switch OFF.
2. Disconnect TCM connector and CVT unit harness connector.
3. Check continuity between TCM connector terminals and CVT unit harness connector terminals.

Item	Connector	Terminal	Continuity
TCM	E32	42	Yes
CVT unit harness connector	F46	19	
TCM	E32	46	Yes
CVT unit harness connector	F46	20	

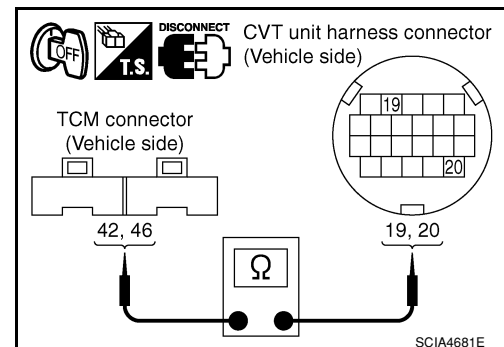

4. If OK, check harness for short to ground and short to power.
5. Reinstall any part removed.

A

B

CVT

D

E

F

G

H

I

J

K

L

M

N

O

P

DTC P0845 TRANSMISSION FLUID PRESSURE SENSOR B CIRCUIT (PRI PRESSURE SENSOR)

< SERVICE INFORMATION >

OK or NG

- OK >> Replace TCM. Refer to [CVT-8, "Service After Replacing TCM and Transaxle Assembly"](#) .
- NG >> Repair open circuit or short to ground or short to power in harness or connectors.

4.CHECK HARNESS BETWEEN TCM AND TRANSMISSION FLUID PRESSURE SENSOR B (PRIMARY PRESSURE SENSOR)

1. Turn ignition switch OFF.
2. Disconnect TCM connector and CVT unit harness connector.
3. Check continuity between TCM connector terminal and CVT unit harness connector terminal.

Item	Connector	Terminal	Continuity
TCM	E32	41	Yes
CVT unit harness connector	F46	25	

4. If OK, check harness for short to ground and short to power.
5. Reinstall any part removed.

OK or NG

- OK >> GO TO 5.
- NG >> Repair open circuit or short to ground or short to power in harness or connectors.

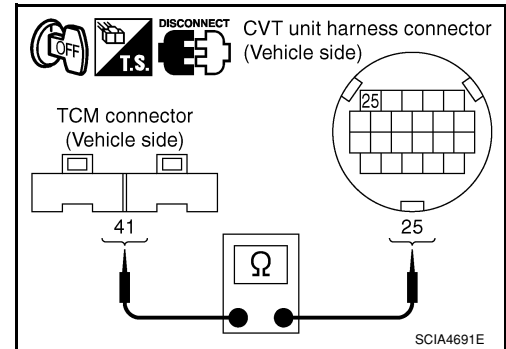

5.CHECK DTC

Perform [CVT-115, "DTC Confirmation Procedure"](#) .

OK or NG

- OK >> **INSPECTION END**
- NG >> GO TO 6.

6.CHECK TCM

1. Check TCM input/output signals. Refer to [CVT-45, "TCM Terminal and Reference Value"](#) .
2. If NG, re-check TCM pin terminals for damage or loose connection with harness connector.

OK or NG

- OK >> Replace the transaxle assembly. Refer to [CVT-178, "Removal and Installation"](#) .
- NG >> Repair or replace damaged parts.

DTC P0868 SECONDARY PRESSURE DOWN

< SERVICE INFORMATION >

DTC P0868 SECONDARY PRESSURE DOWN

Description

INFOID:000000001703593

- The pressure control solenoid valve B (secondary pressure solenoid valve) is included in the control valve assembly.
- The pressure control solenoid valve B (secondary pressure solenoid valve) regulates the secondary pressure to suit the driving condition in response to a signal sent from the TCM.

CONSULT-III Reference Value in Data Monitor Mode

INFOID:000000001703594

Remarks: Specification data are reference values.

Item name	Condition	Display value (Approx.)
SEC PRESS	"N" position idle	0.8 MPa

On Board Diagnosis Logic

INFOID:000000001703595

- This is not an OBD-II self-diagnostic item.
- Diagnostic trouble code "P0868 SEC/PRESS DOWN" with CONSULT-III is detected when secondary fluid pressure is too low compared with the commanded value while driving.

Possible Cause

INFOID:000000001703596

- Harness or connectors
(Solenoid circuit is open or shorted.)
- Pressure control solenoid valve B (Secondary pressure solenoid valve) system
- Transmission fluid pressure sensor A (Secondary pressure sensor)
- Line pressure control system

DTC Confirmation Procedure

INFOID:000000001703597

CAUTION:

Always drive vehicle at a safe speed.

NOTE:

If "DTC Confirmation Procedure" has been previously performed, always turn ignition switch OFF and wait at least 10 seconds before performing the next test.

After the repair, perform the following procedure to confirm the malfunction is eliminated.

Ⓜ WITH CONSULT-III

1. Turn ignition switch ON and select "DATA MONITOR" mode for "TRANSMISSION" with CONSULT-III.
2. Make sure that output voltage of CVT fluid temperature sensor is within the range below.
ATF TEMP SEN: 1.0 - 2.0 V
If out of range, drive the vehicle to decrease the voltage (warm up the fluid) or stop engine to increase the voltage (cool down the fluid)
3. Start engine and maintain the following conditions for at least 10 consecutive seconds.
VEHICLE SPEED (accelerate slowly): 0 → 50 km/h (31 MPH)
ACC PEDAL OPEN: 0.5/8 - 1.0/8
RANGE: "D" position
4. If DTC is detected, go to [CVT-119, "Diagnosis Procedure"](#).

Diagnosis Procedure

INFOID:000000001703598

1. CHECK INPUT SIGNAL

Ⓜ With CONSULT-III

1. Start engine.
2. Select "MAIN SIGNALS" in "DATA MONITOR" mode for "TRANSMISSION" with CONSULT-III.
3. Start vehicle and read out the value of "SEC PRESS".

Item name	Condition	Display value (Approx.)
SEC PRESS	"N" position idle	0.8 MPa

DTC P0868 SECONDARY PRESSURE DOWN

< SERVICE INFORMATION >

OK or NG

- OK >> GO TO 5.
- NG >> GO TO 2.

2.CHECK LINE PRESSURE

Perform line pressure test. Refer to [CVT-36. "Inspections before Trouble Diagnosis"](#).

OK or NG

- OK >> GO TO 3.
- NG >> Repair or replace damaged parts. Refer to [CVT-36. "Inspections before Trouble Diagnosis"](#).

3.DETECT MALFUNCTIONING ITEM

Check the following:

- Pressure control solenoid valve B (Secondary pressure solenoid valve). Refer to [CVT-107. "Component Inspection"](#).
- Pressure control solenoid valve A (Line pressure solenoid valve). Refer to [CVT-98. "Component Inspection"](#).

OK or NG

- OK >> GO TO 4.
- NG >> Repair or replace damaged parts.

4.CHECK TRANSMISSION FLUID PRESSURE SENSOR A (SECONDARY PRESSURE SENSOR) SYSTEM

Check transmission fluid pressure sensor A (secondary pressure sensor) system. Refer to [CVT-109](#).

OK or NG

- OK >> GO TO 5.
- NG >> Repair or replace damaged parts.

5.DETECT MALFUNCTIONING ITEM

Check the following:

- Power supply and ground circuit for TCM. Refer to [CVT-122. "Wiring Diagram - CVT - POWER"](#).
- The TCM pin terminals for damage or loose connection with harness connector.

OK or NG

- OK >> GO TO 6.
- NG >> Repair or replace damaged parts.

6.CHECK DTC

Perform [CVT-119. "DTC Confirmation Procedure"](#).

OK or NG

- OK >> **INSPECTION END**
- NG >> Replace the transaxle assembly. Refer to [CVT-178. "Removal and Installation"](#).

DTC P1701 TRANSMISSION CONTROL MODULE (POWER SUPPLY)

< SERVICE INFORMATION >

DTC P1701 TRANSMISSION CONTROL MODULE (POWER SUPPLY)

Description

INFOID:000000001703599

When the power supply to the TCM is cut OFF, for example because the battery is removed, and the self-diagnosis memory function stops, malfunction is detected.

NOTE:

Since "P1701 TCM-POWER SUPPLY" will be indicated when replacing TCM, perform diagnosis after erasing "SELF-DIAG RESULTS"

On Board Diagnosis Logic

INFOID:000000001703600

- This is not an OBD-II self-diagnostic item.
- Diagnostic trouble code "P1701 TCM-POWER SUPPLY" with CONSULT-III is detected when TCM does not receive the voltage signal from the battery power supply.
- This is not a malfunction message. (Whenever shutting OFF a power supply to the TCM, this message appears on the screen.)

Possible Cause

INFOID:000000001703601

Harness or connectors
(Battery or ignition switch and TCM circuit is open or shorted.)

DTC Confirmation Procedure

INFOID:000000001703602

NOTE:

If "DTC Confirmation Procedure" has been previously conducted, always turn ignition switch OFF and wait at least 10 seconds before conducting the next test.

After the repair, perform the following procedure to confirm the malfunction is eliminated.

Ⓜ WITH CONSULT-III

1. Turn ignition switch ON. (Do not start engine.)
2. Select "DATA MONITOR" mode for "TRANSMISSION" with CONSULT-III.
3. Wait for at least 2 consecutive seconds.
4. If DTC is detected, go to [CVT-123. "Diagnosis Procedure"](#).

DTC P1701 TRANSMISSION CONTROL MODULE (POWER SUPPLY)

< SERVICE INFORMATION >

Wiring Diagram - CVT - POWER

INFOID:000000001703603

CVT-POWER-01

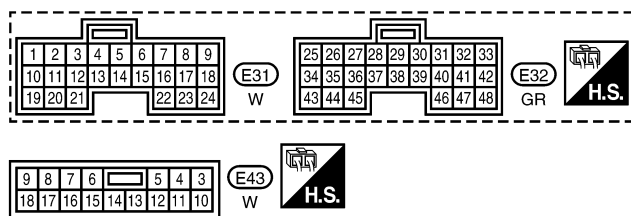
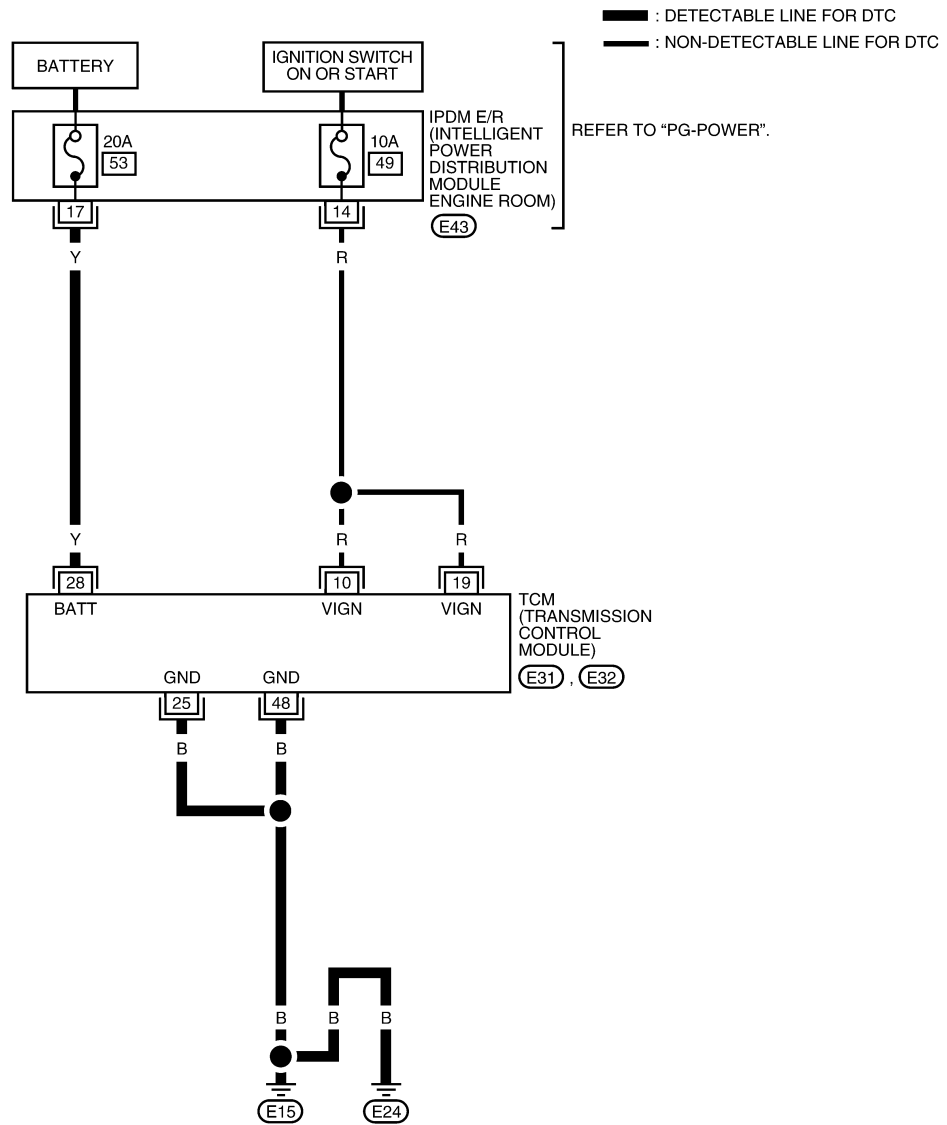

REFER TO THE FOLLOWING.

(F8) - SUPER MULTIPLE JUNCTION (SMJ)

BCWA0679E

TCM TERMINALS AND REFERENCE VALUES

Refer to [CVT-45, "TCM Terminal and Reference Value"](#).

DTC P1701 TRANSMISSION CONTROL MODULE (POWER SUPPLY)

< SERVICE INFORMATION >

INFOID:000000001703604

Diagnosis Procedure

1. CHECK DTC

1. Turn ignition switch ON. (Do not start engine.)
2. Select "SELF-DIAG RESULTS" mode for "TRANSMISSION" with CONSULT-III.
3. Erase self-diagnostic results. Refer to [CVT-26. "OBD-II Diagnostic Trouble Code \(DTC\)"](#).
4. Turn ignition switch OFF, and wait for 5 seconds or more.
5. Start engine.
6. Confirm self-diagnostic results again. Refer to [CVT-47. "CONSULT-III Function \(TRANSMISSION\)"](#).

Is the "P1701 TCM-POWER SUPPLY" displayed?

YES >> GO TO 2.

NO >> **INSPECTION END**

2. CHECK TCM POWER SOURCE, STEP 1

1. Turn ignition switch OFF.
2. Check voltage between TCM connector terminal and ground.

Name	Connector	Terminal	Condition	Voltage (Approx.)
Power supply (memory back-up)	E32	28 - Ground	Always	Battery voltage

OK or NG

OK >> GO TO 3.

NG >> GO TO 4.

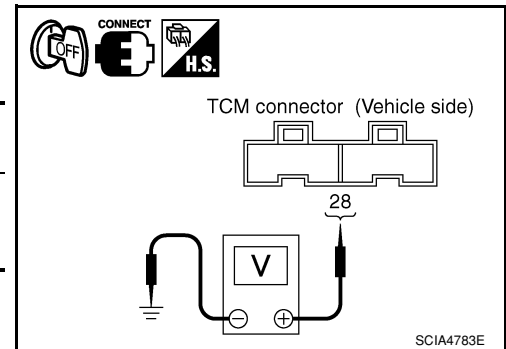

3. CHECK TCM POWER SOURCE, STEP 2

1. Turn ignition switch ON. (Do not start engine.)
2. Check voltage between TCM connector terminals and ground.

Name	Connector	Terminal	Condition	Voltage (Approx.)
Power supply	E31	10 - Ground		Battery voltage
				0 V
Power supply	E31	19 - Ground		Battery voltage
				0 V
Power supply (memory back-up)	E32	28 - Ground	Always	Battery voltage

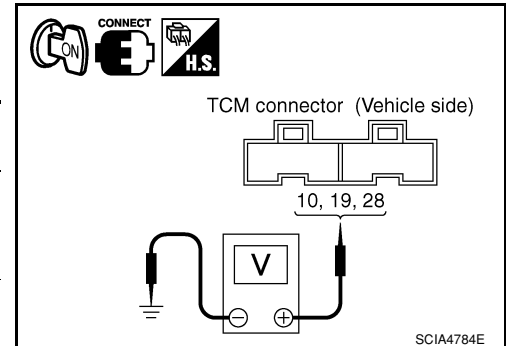

OK or NG

OK >> GO TO 5.

NG >> GO TO 4.

4. DETECT MALFUNCTIONING ITEM

Check the following.

- Harness for short or open between battery and TCM connector terminal 28
- Harness for short or open between ignition switch and TCM connector terminal 10, 19

DTC P1701 TRANSMISSION CONTROL MODULE (POWER SUPPLY)

< SERVICE INFORMATION >

- 10 A fuse (No.49, located in the IPDM E/R)
- 20 A fuse (No.53, located in the IPDM E/R)
- Ignition switch. Refer to [PG-3](#).

OK or NG

- OK >> GO TO 5.
NG >> Repair or replace damaged parts.

5.CHECK TCM GROUND CIRCUIT

1. Turn ignition switch OFF.
2. Disconnect TCM connector.
3. Check continuity between TCM connector terminals and ground.

Name	Connector	Terminal	Continuity
Ground	E32	25	Yes
		48	

OK or NG

- OK >> GO TO 6.
NG >> Repair open circuit or short to ground or short to power in harness or connectors.

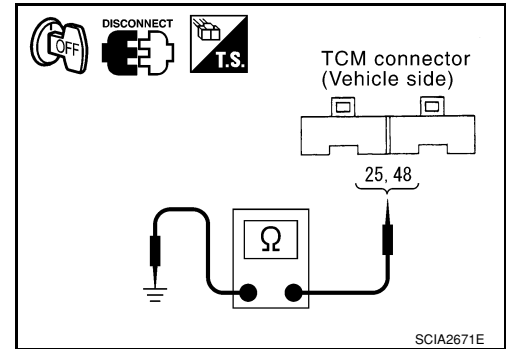

6.CHECK DTC

Perform [CVT-121, "DTC Confirmation Procedure"](#).

OK or NG

- OK >> **INSPECTION END**
NG >> GO TO 7.

7.CHECK TCM

1. Check TCM input/output signals. Refer to [CVT-45, "TCM Terminal and Reference Value"](#).
2. If NG, re-check TCM pin terminals for damage or loose connection with harness connector.

OK or NG

- OK >> **INSPECTION END**
NG >> Repair or replace damaged parts.

DTC P1705 THROTTLE POSITION SENSOR

< SERVICE INFORMATION >

DTC P1705 THROTTLE POSITION SENSOR

Description

INFOID:000000001703605

Electric throttle control actuator consists of throttle control motor, accelerator pedal position sensor, throttle position sensor etc. The actuator sends a signal to the ECM, and ECM sends the signal to TCM with CAN communication.

CONSULT-III Reference Value in Data Monitor Mode

INFOID:000000001703606

Remarks: Specification data are reference values.

Item name	Condition	Display value (Approx.)
ACC PEDAL OPEN	Released accelerator pedal - Fully depressed accelerator pedal	0.0/8 - 8.0/8

On Board Diagnosis Logic

INFOID:000000001703607

- This is not an OBD-II self-diagnostic item.
- Diagnostic trouble code "P1705 TP SEN/CIRC A/T" with CONSULT-III is detected when TCM does not receive the proper accelerator pedal position signals (input by CAN communication) from ECM.

Possible Cause

INFOID:000000001703608

- ECM
- Harness or connectors
(CAN communication line is open or shorted.)

DTC Confirmation Procedure

INFOID:000000001703609

NOTE:

If "DTC Confirmation Procedure" has been previously performed, always turn ignition switch OFF and wait at least 10 seconds before performing the next test.

After the repair, perform the following procedure to confirm the malfunction is eliminated.

Ⓜ WITH CONSULT-III

1. Turn ignition switch ON. (Do not start engine.)
2. Select "DATA MONITOR" mode for "TRANSMISSION" with CONSULT-III.
3. Depress accelerator pedal fully and release it, then wait for 5 seconds.
4. If DTC is detected, go to [CVT-125, "Diagnosis Procedure"](#).

Diagnosis Procedure

INFOID:000000001703610

1.CHECK CAN COMMUNICATION LINE

Perform the self-diagnosis check. Refer to [CVT-47, "CONSULT-III Function \(TRANSMISSION\)"](#).

Is any malfunction of the "U1000 CAN COMM CIRCUIT" indicated?

YES >> Check the CAN communication line. Refer to [CVT-56](#).

NO >> GO TO 2.

2.CHECK INPUT SIGNAL

Ⓜ With CONSULT-III

1. Turn ignition switch ON. (Do not start engine.)
2. Select "ECU INPUT SIGNALS" in "DATA MONITOR" mode for "TRANSMISSION" with CONSULT-III.
3. Read out the value of "ACC PEDAL OPEN".

Item name	Condition	Display value (Approx.)
ACC PEDAL OPEN	Release accelerator pedal.	0.0/8
	↓ Fully depressed accelerator pedal	↓ 8.0/8

OK or NG

DTC P1705 THROTTLE POSITION SENSOR

< SERVICE INFORMATION >

- OK >> GO TO 4.
- NG >> GO TO 3.

3. CHECK DTC WITH ECM

With CONSULT-III

1. Turn ignition switch ON. (Do not start engine.)
2. Select "SELF-DIAG RESULTS" mode for "ENGINE" with CONSULT-III. Refer to [EC-109. "CONSULT-II Function \(ENGINE\)".](#)

OK or NG

- OK >> GO TO 4.
- NG >> Check the DTC Detected Item. Go to [EC-109. "CONSULT-II Function \(ENGINE\)".](#)

4. CHECK DTC

Perform [CVT-125. "DTC Confirmation Procedure".](#)

OK or NG

- OK >> **INSPECTION END**
- NG >> Repair or replace damaged parts.

DTC P1722 ESTM VEHICLE SPEED SIGNAL

< SERVICE INFORMATION >

DTC P1722 ESTM VEHICLE SPEED SIGNAL

Description

INFOID:000000001703611

The vehicle speed signal is transmitted from ABS actuator and electric unit (control unit) to TCM by CAN communication line.

CONSULT-III Reference Value in Data Monitor Mode

INFOID:000000001703612

Remarks: Specification data are reference values.

Item name	Condition	Display value
ESTM VSP SIG	During driving	Approximately matches the speedometer reading.
VEHICLE SPEED		

On Board Diagnosis Logic

INFOID:000000001703613

- This is not an OBD-II self-diagnostic item.
- Diagnostic trouble code “P1722 ESTM VEH SPD SIG” with CONSULT-III is detected when TCM does not receive the proper vehicle speed signal (input by CAN communication) from ABS actuator and electric unit (control unit).

Possible Cause

INFOID:000000001703614

- Harness or connectors
(Sensor circuit is open or shorted.)
- ABS actuator and electric unit (control unit)

DTC Confirmation Procedure

INFOID:000000001703615

CAUTION:

Always drive vehicle at a safe speed.

NOTE:

If “DTC Confirmation Procedure” has been previously performed, always turn ignition switch OFF and wait at least 10 seconds before performing the next test.

After the repair, touch “ERASE” on “SELF-DIAG RESULTS” and then perform the following procedure to confirm the malfunction is eliminated.

Ⓜ WITH CONSULT-III

1. Turn ignition switch ON. (Do not start engine.)
2. Select “DATA MONITOR” mode for “TRANSMISSION” with CONSULT-III.
3. Start engine and maintain the following conditions for at least 5 consecutive seconds.
ACC PEDAL OPEN: 1.0/8 or less
VEHICLE SPEED SE: 30 km/h (17 MPH) or more
4. If DTC is detected, go to [CVT-127. "Diagnosis Procedure"](#).

Diagnosis Procedure

INFOID:000000001703616

1. CHECK CAN COMMUNICATION LINE

Perform the self-diagnosis check. Refer to [CVT-47. "CONSULT-III Function \(TRANSMISSION\)"](#).

Is any malfunction of the “U1000 CAN COMM CIRCUIT” indicated?

- YES >> Check CAN communication line. Refer to [CVT-56](#).
NO >> GO TO 2.

2. CHECK ABS ACTUATOR AND ELECTRIC UNIT (CONTROL UNIT)

Perform ABS actuator and electric unit (control unit) self-diagnosis check. Refer to [BRC-18. "CONSULT-III Function \(ABS\)"](#).

OK or NG

- OK >> GO TO 3.
NG >> Repair or replace damaged parts.

DTC P1722 ESTM VEHICLE SPEED SIGNAL

< SERVICE INFORMATION >

3. CHECK INPUT SIGNALS

With CONSULT-III

1. Start engine.
2. Select "SELECTION FROM MENU" in "DATA MONITOR" mode for "TRANSMISSION" with CONSULT-III.
3. Drive vehicle and read out the value of "VEHICLE SPEED" and "ESTM VSP SIG".

Item name	Condition	Display value
ESTM VSP SIG	During driving	Approximately matches the speedometer reading.
VEHICLE SPEED		

4. Check if there is a great difference between the two values.

OK or NG

- OK >> GO TO 5.
NG >> GO TO 4.

4. CHECK TCM

Check TCM input/output signals. Refer to [CVT-45. "TCM Terminal and Reference Value"](#).

OK or NG

- OK >> GO TO 5.
NG >> Repair or replace damaged parts.

5. CHECK DTC

Perform [CVT-127. "DTC Confirmation Procedure"](#).

OK or NG

- OK >> **INSPECTION END**
NG >> GO TO 2.

DTC P1723 CVT SPEED SENSOR FUNCTION

< SERVICE INFORMATION >

DTC P1723 CVT SPEED SENSOR FUNCTION

Description

INFOID:000000001703617

- The input speed sensor (primary speed sensor) is included in the control valve assembly.
- The vehicle speed sensor CVT [output speed sensor (secondary speed sensor)] detects the revolution of the idler gear and generates a pulse signal. The pulse signal is sent to the TCM, which converts it into vehicle speed.
- The input speed sensor (primary speed sensor) detects the primary pulley revolution speed and sends a signal to the TCM.

On Board Diagnosis Logic

INFOID:000000001703618

- This is not an OBD-II self-diagnostic item.
- Diagnostic trouble code “P1723 CVT SPD SEN/FNCTN” with CONSULT-III is detected when there is a great difference between the vehicle speed signal and the secondary speed sensor signal.

CAUTION:

One of the “P0720 VEH SPD SEN/CIR AT”, the “P0715 INPUT SPD SEN/CIRC” or the “P0725 ENGINE SPEED SIG” is displayed with the DTC at the same time.

Possible Cause

INFOID:000000001703619

- Harness or connectors
(Sensor circuit is open or shorted.)
- Output speed sensor (Secondary speed sensor)
- Input speed sensor (Primary speed sensor)
- Engine speed signal system

DTC Confirmation Procedure

INFOID:000000001703620

CAUTION:

Always drive vehicle at a safe speed.

NOTE:

If “DTC Confirmation Procedure” has been previously performed, always turn ignition switch OFF and wait at least 10 seconds before performing the next test.

After the repair, touch “ERASE” on “SELF-DIAG RESULTS” and then perform the following procedure to confirm the malfunction is eliminated.

④ WITH CONSULT-III

1. Turn ignition switch ON and select “DATA MONITOR” mode for “TRANSMISSION” with CONSULT-III.
2. Start engine and maintain the following conditions for at least 5 consecutive seconds.
VEHICLE SPEED SE: 10 km/h (6 MPH) or more
ACC PEDAL OPEN: More than 1.0/8
RANGE: “D” position
ENG SPEED: 450 rpm or more
Driving location: Driving the vehicle uphill (increased engine load) will help maintain the driving conditions required for this test.
3. If DTC is detected, go to [CVT-129. "Diagnosis Procedure"](#).

Diagnosis Procedure

INFOID:000000001703621

1.CHECK STEP MOTOR FUNCTION

Perform the self-diagnosis check. Refer to [CVT-47. "CONSULT-III Function \(TRANSMISSION\)"](#).

Is a malfunction in the step motor function indicated in the results?

YES >> Repair or replace damaged parts. (Check the step motor function. Refer to [CVT-141.](#))

NO >> GO TO 2.

2.CHECK OUTPUT SPEED SENSOR (SECONDARY SPEED SENSOR SYSTEM) AND INPUT SPEED SENSOR (PRIMARY SPEED SENSOR) SYSTEM

Check output speed sensor (secondary speed sensor) system and input speed sensor (primary speed sensor) system. Refer to [CVT-80](#), [CVT-76](#).

DTC P1723 CVT SPEED SENSOR FUNCTION

< SERVICE INFORMATION >

OK or NG

OK >> GO TO 3.

NG >> Repair or replace damaged parts.

3. CHECK ENGINE SPEED SIGNAL SYSTEM

Check engine speed signal system. Refer to [CVT-85](#).

OK or NG

OK >> GO TO 4.

NG >> Repair or replace damaged parts. Refer to [EC-531](#).

4. DETECT MALFUNCTIONING ITEM

Check the following:

- Power supply and ground circuit for TCM. Refer to [CVT-121](#).
- The TCM pin terminals for damage or loose connection with harness connector.

OK or NG

OK >> GO TO 5.

NG >> Repair or replace damaged parts.

5. CHECK DTC

Perform [CVT-129, "DTC Confirmation Procedure"](#).

OK or NG

OK >> **INSPECTION END**

NG >> Replace TCM or transaxle assembly. Refer to [CVT-8, "Service After Replacing TCM and Transaxle Assembly"](#), [CVT-178, "Removal and Installation"](#).

DTC P1726 ELECTRIC THROTTLE CONTROL SYSTEM

< SERVICE INFORMATION >

DTC P1726 ELECTRIC THROTTLE CONTROL SYSTEM

Description

INFOID:000000001703622

Electric throttle control actuator consists of throttle control motor, accelerator pedal position sensor, throttle position sensor etc. The actuator sends a signal to the ECM, and ECM sends the signal to TCM with CAN communication.

On Board Diagnosis Logic

INFOID:000000001703623

- This is not an OBD-II self-diagnostic item.
- Diagnostic trouble code "P1726 ELEC TH CONTROL" with CONSULT-III is detected when the electronically controlled throttle for ECM is malfunctioning.

Possible Cause

INFOID:000000001703624

Harness or connectors
(Sensor circuit is open or shorted.)

DTC Confirmation Procedure

INFOID:000000001703625

NOTE:

If "DTC Confirmation Procedure" has been previously performed, always turn ignition switch OFF and wait at least 10 seconds before performing the next test.

After the repair, touch "ERASE" on "SELF-DIAG RESULTS" and then perform the following procedure to confirm the malfunction is eliminated.

Ⓟ WITH CONSULT-III

1. Turn ignition switch ON. (Do not start engine.)
2. Select "DATA MONITOR" mode for "TRANSMISSION" with CONSULT-III.
3. Start engine and let it idle for 5 second.
4. If DTC is detected, go to [CVT-131, "Diagnosis Procedure"](#).

Diagnosis Procedure

INFOID:000000001703626

1.CHECK DTC WITH ECM

Ⓟ With CONSULT-III

1. Turn ignition switch ON. (Do not start engine.)
2. Select "SELF-DIAG RESULTS" mode for "ENGINE" with CONSULT-III. Refer to [EC-109, "CONSULT-II Function \(ENGINE\)"](#).

OK or NG

- OK >> GO TO 2.
NG >> Check the DTC Detected Item. Refer to [EC-109, "CONSULT-II Function \(ENGINE\)"](#).
• If CAN communication line is detected, go to [CVT-56](#).

2.CHECK DTC

Perform [CVT-131, "DTC Confirmation Procedure"](#).

OK or NG

- OK >> **INSPECTION END**
NG >> GO TO 3.

3.DETECT MALFUNCTIONING ITEM

Check the following:

- The TCM pin terminals for damage or loose connection with harness connector.

OK or NG

- OK >> Replace TCM. Refer to [CVT-8, "Service After Replacing TCM and Transaxle Assembly"](#).
NG >> Repair or replace damaged parts.

DTC P1740 LOCK-UP SELECT SOLENOID VALVE CIRCUIT

< SERVICE INFORMATION >

DTC P1740 LOCK-UP SELECT SOLENOID VALVE CIRCUIT

Description

INFOID:000000001703627

- The lock-up select solenoid valve is included in the control valve assembly.
- The lock-up select solenoid valve controls lock-up clutch pressure or forward clutch pressure (reverse brake pressure).
- When controlling lock-up clutch, the valve is turned OFF. When controlling forward clutch, it is turned ON.

CONSULT-III Reference Value in Data Monitor Mode

INFOID:000000001703628

Item name	Condition	Display value
LUSEL SOL OUT	Selector lever in "P" and "N" positions	ON
	Wait at least for 5 seconds with the selector lever in "R", "D" and "L" positions	OFF

On Board Diagnosis Logic

INFOID:000000001703629

- This is an OBD-II self-diagnostic item.
- Diagnostic trouble code "P1740 LU-SLCT SOL/CIRC" with CONSULT-III is detected under the following conditions.
 - When TCM compares target value with monitor value and detects an irregularity.

Possible Cause

INFOID:000000001703630

- Lock-up select solenoid valve
- Harness or connectors
(Solenoid circuit is open or shorted.)

DTC Confirmation Procedure

INFOID:000000001703631

CAUTION:

Always drive vehicle at a safe speed.

NOTE:

If "DTC Confirmation Procedure" has been previously performed, always turn ignition switch OFF and wait at least 10 seconds before performing the next test.

After the repair, touch "ERASE" on "SELF-DIAG RESULTS" and then perform the following procedure to confirm the malfunction is eliminated.

WITH CONSULT-III

1. Turn ignition switch ON. (Do not start engine.)
2. Select "DATA MONITOR" mode for "TRANSMISSION" with CONSULT-III.
3. Start engine and maintain the following conditions for at least 5 consecutive seconds.
RANGE: "D" position and "N" position
(At each time, wait for 5 seconds.)
4. If DTC is detected, go to [CVT-134. "Diagnosis Procedure"](#) .

WITH GST

Follow the procedure "WITH CONSULT-III".

DTC P1740 LOCK-UP SELECT SOLENOID VALVE CIRCUIT

< SERVICE INFORMATION >

Wiring Diagram - CVT - L/USSV

INFOID:000000001703632

CVT-L/USSV-01

: DETECTABLE LINE FOR DTC
 : NON-DETECTABLE LINE FOR DTC

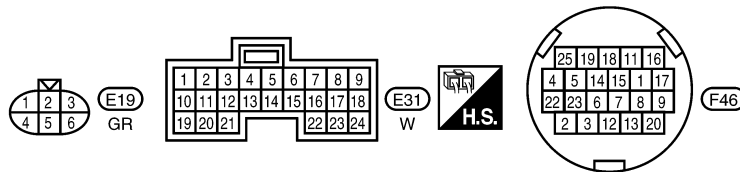
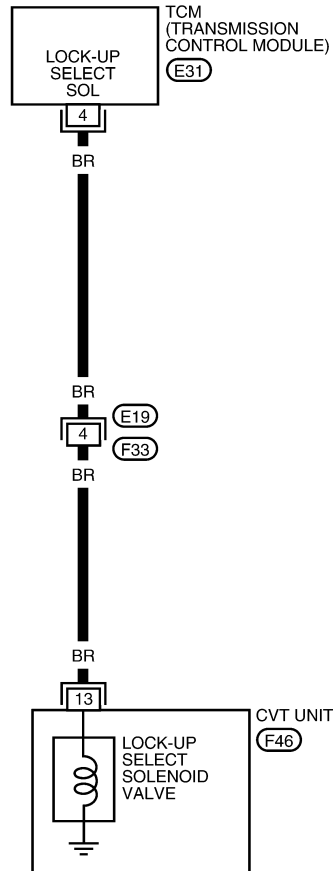

TCM TERMINALS AND REFERENCE VALUES
 Refer to [CVT-45, "TCM Terminal and Reference Value"](#).

BCWA0680E

DTC P1740 LOCK-UP SELECT SOLENOID VALVE CIRCUIT

< SERVICE INFORMATION >

Diagnosis Procedure

INFOID:000000001703633

1. CHECK INPUT SIGNAL

Ⓜ With CONSULT-III

- Turn ignition switch ON.
- Select "SELECTION FROM MENU" in "DATA MONITOR" mode for "TRANSMISSION" with CONSULT-III.
- Read out the value of "LUSEL SOL OUT".

Item name	Condition	Display value
LUSEL SOL OUT	Selector lever in "P" and "N" positions	ON
	Wait at least for 5 seconds with the selector lever in "R", "D" and "L" positions	OFF

ⓧ Without CONSULT-III

- Turn ignition switch ON.
- Check voltage between TCM connector terminal and ground.

Name	Connector	Terminal	Condition	Voltage (Approx.)
Lock-up select solenoid valve	E31	4 - Ground	Selector lever in "P" and "N" positions	Battery voltage
			Wait at least for 5 seconds with the selector lever in "R", "D" and "L" positions	0 V

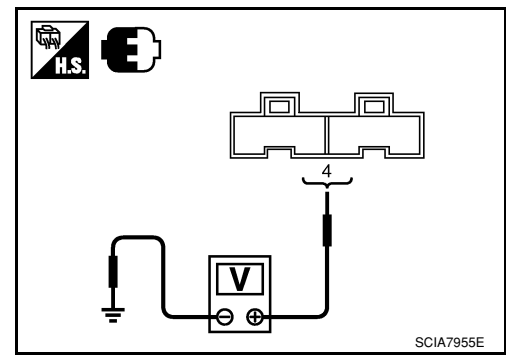

- Turn ignition switch OFF.
- Disconnect the TCM connector.
- Check if there is continuity between connector terminal and ground.

OK or NG

- OK >> GO TO 5.
NG >> GO TO 2.

2. CHECK LOCK-UP SELECT SOLENOID VALVE CIRCUIT

- Turn ignition switch OFF.
- Disconnect TCM connector.
- Check resistance between TCM connector terminal and ground.

Solenoid valve	Connector	Terminal	Resistance (Approx.)
Lock-up select solenoid valve	E31	4 - Ground	6 - 19 Ω

OK or NG

- OK >> GO TO 5.
NG >> GO TO 3.

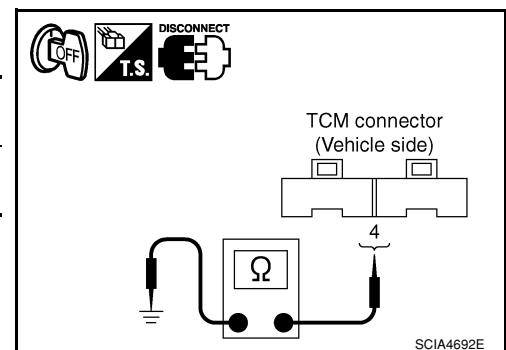

3. CHECK VALVE RESISTANCE

- Turn ignition switch OFF.
- Disconnect CVT unit harness connector.

DTC P1740 LOCK-UP SELECT SOLENOID VALVE CIRCUIT

< SERVICE INFORMATION >

- Check resistance between CVT unit harness connector terminal and ground.

Solenoid valve	Connector	Terminal	Resistance (Approx.)
Lock-up select solenoid valve	F46	13 - Ground	6 - 19 Ω

OK or NG

- OK >> GO TO 4.
- NG >> Replace the transaxle assembly. Refer to [CVT-178](#), "[Removal and Installation](#)".

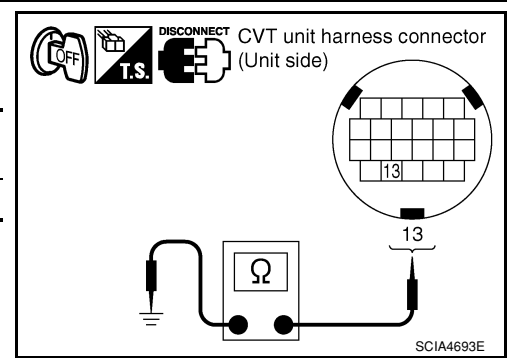

4. CHECK HARNESS BETWEEN TCM AND LOCK-UP SELECT SOLENOID VALVE

- Turn ignition switch OFF.
- Disconnect TCM connector.
- Check continuity between TCM connector terminal and CVT unit harness connector terminal.

Item	Connector	Terminal	Continuity
TCM	E31	4	Yes
CVT unit harness connector	F46	13	

- If OK, check harness for short to ground and short to power.
- Reinstall any part removed.

OK or NG

- OK >> GO TO 5.
- NG >> Repair open circuit or short to ground or short to power in harness or connectors.

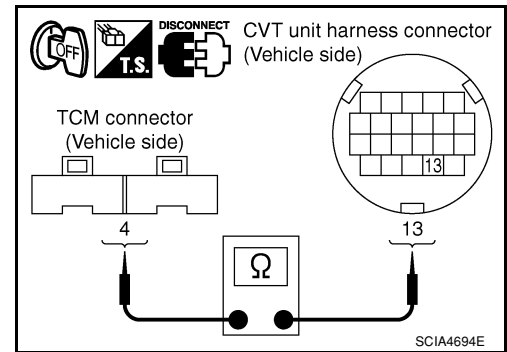

5. CHECK DTC

Perform [CVT-132](#), "[DTC Confirmation Procedure](#)".

OK or NG

- OK >> **INSPECTION END**
- NG >> GO TO 6.

6. CHECK TCM

- Check TCM input/output signals. Refer to [CVT-45](#), "[TCM Terminal and Reference Value](#)".
- If NG, re-check TCM pin terminals for damage or loose connection with harness connector.

OK or NG

- OK >> **INSPECTION END**
- NG >> 1. Repair or replace damaged parts.
2. Replace TCM. Refer to [CVT-8](#), "[Service After Replacing TCM and Transaxle Assembly](#)".

Component Inspection

INFOID:000000001703634

LOCK-UP SELECT SOLENOID VALVE

- Turn ignition switch OFF.
- Disconnect CVT unit harness connector.
- Check resistance between CVT unit harness connector terminal and ground.

Solenoid valve	Connector	Terminal	Resistance (Approx.)
Lock-up select solenoid valve	F46	13 - Ground	6 - 19 Ω

- If NG, replace the transaxle assembly. Refer to [CVT-178](#), "[Removal and Installation](#)".

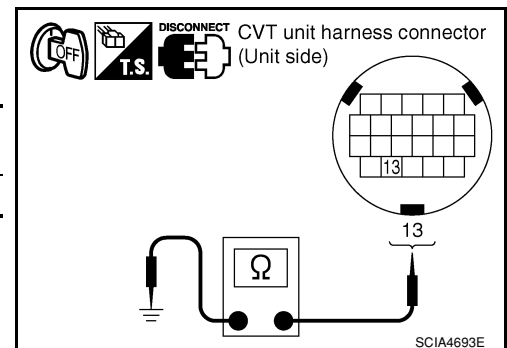

DTC P1745 LINE PRESSURE CONTROL

< SERVICE INFORMATION >

DTC P1745 LINE PRESSURE CONTROL

Description

INFOID:000000001703635

The pressure control solenoid valve A (line pressure solenoid valve) regulates the oil pump discharge pressure to suit the driving condition in response to a signal sent from the TCM.

On Board Diagnosis Logic

INFOID:000000001703636

- This is not an OBD-II self-diagnostic item.
- Diagnostic trouble code "P1745 L/PRESS CONTROL" with CONSULT-III is detected when TCM detects the unexpected line pressure.

Possible Cause

INFOID:000000001703637

TCM

DTC Confirmation Procedure

INFOID:000000001703638

NOTE:

If "DTC Confirmation Procedure" has been previously performed, always turn ignition switch OFF and wait at least 10 seconds before performing the next test.

After the repair, touch "ERASE" on "SELF-DIAG RESULTS" and then perform the following procedure to confirm the malfunction is eliminated.

Ⓟ WITH CONSULT-III

1. Turn ignition switch ON and select "DATA MONITOR" mode for "TRANSMISSION" with CONSULT-III.
2. Make sure that output voltage of CVT fluid temperature sensor is within the range below.
ATF TEMP SEN: 1.0 - 2.0 V
If out of range, drive the vehicle to decrease the voltage (warm up the fluid) or stop engine to increase the voltage (cool down the fluid)
3. If DTC is detected, go to [CVT-136. "Diagnosis Procedure"](#) .

Diagnosis Procedure

INFOID:000000001703639

1. CHECK DTC

1. Turn ignition switch ON. (Do not start engine.)
2. Select "SELF-DIAG RESULTS" mode for "TRANSMISSION" with CONSULT-III.
3. Erase self-diagnostic results. Refer to [CVT-26. "OBD-II Diagnostic Trouble Code \(DTC\)"](#).
4. Turn ignition switch OFF, and wait for 10 seconds or more.
5. Start engine.
6. Confirm self-diagnostic results again. Refer to [CVT-47. "CONSULT-III Function \(TRANSMISSION\)"](#) .

Is the "P1745 L/PRESS CONTROL" displayed?

- YES >> Replace TCM. Refer to [CVT-8. "Service After Replacing TCM and Transaxle Assembly"](#) .
- NO >> **INSPECTION END**

DTC P1777 STEP MOTOR - CIRCUIT

< SERVICE INFORMATION >

DTC P1777 STEP MOTOR - CIRCUIT

Description

INFOID:000000001703640

- The step motor is included in the control valve assembly.
- The step motor changes the step with turning 4 coils ON/OFF according to the signal from TCM. As a result, the flow of line pressure to primary pulley is changed and pulley ratio is controlled

CONSULT-III Reference Value in Data Monitor Mode

INFOID:000000001703641

Remarks: Specification data are reference values.

Item name	Condition	Display value (Approx.)
STM STEP	During driving	-20 step - 180 step
SMCOIL A		Changes ON⇔OFF.
SMCOIL B		
SMCOIL C		
SMCOIL D		

On Board Diagnosis Logic

INFOID:000000001703642

- This is an OBD-II self-diagnostic item.
- Diagnostic trouble code "P1777 STEP MOTR CIRC" with CONSULT-III is detected under the following conditions.
 - When operating step motor ON and OFF, there is no proper change in the voltage of TCM terminal which corresponds to it.

Possible Cause

INFOID:000000001703643

- Step motor
- Harness or connectors
(Step motor circuit is open or shorted.)

DTC Confirmation Procedure

INFOID:000000001703644

CAUTION:

Always drive vehicle at a safe speed.

NOTE:

If "DTC Confirmation Procedure" has been previously performed, always turn ignition switch OFF and wait at least 10 seconds before performing the next test.

After the repair, touch "ERASE" on "SELF-DIAG RESULTS" and then perform the following procedure to confirm the malfunction is eliminated.

WITH CONSULT-III

1. Turn ignition switch ON and select "DATA MONITOR" mode for "TRANSMISSION" with CONSULT-III.
2. Drive vehicle for at least 5 consecutive seconds.
3. If DTC is detected, go to [CVT-139. "Diagnosis Procedure"](#).

WITH GST

Follow the procedure "WITH CONSULT-III".

DTC P1777 STEP MOTOR - CIRCUIT

< SERVICE INFORMATION >

Wiring Diagram - CVT - STM

INFOID:000000001703645

CVT-STM-01

: DETECTABLE LINE FOR DTC
 : NON-DETECTABLE LINE FOR DTC

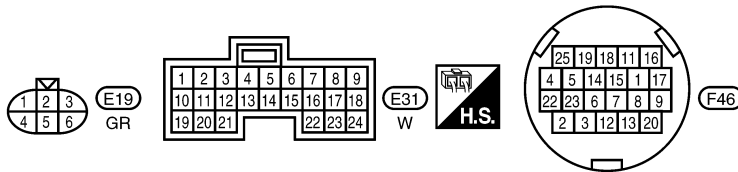
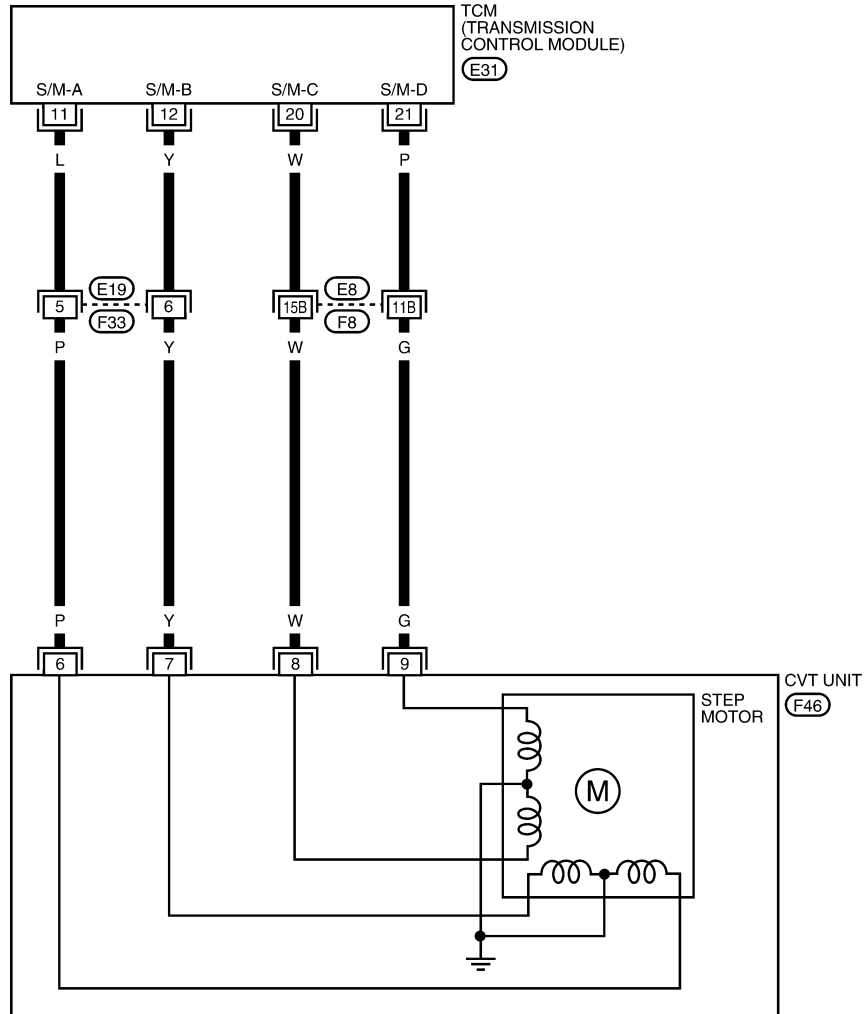

REFER TO THE FOLLOWING.

(F8) - SUPER MULTIPLE JUNCTION (SMJ)

BCWA0681E

TCM TERMINALS AND REFERENCE VALUES

Refer to [CVT-45, "TCM Terminal and Reference Value"](#).

DTC P1777 STEP MOTOR - CIRCUIT

< SERVICE INFORMATION >

Diagnosis Procedure

INFOID:000000001703646

1. CHECK INPUT SIGNALS

With CONSULT-III

1. Start engine.
2. Select "SELECTION FROM MENU" in "DATA MONITOR" mode for "TRANSMISSION" with CONSULT-III.
3. Start vehicle and read out the value of "STM STEP", "SMCOIL A", "SMCOIL B", "SMCOIL C", and "SMCOIL D".

Item name	Condition	Display value (Approx.)
STM STEP	During driving	-20 step - 180 step
SMCOIL A		Changes ON⇔OFF.
SMCOIL B		
SMCOIL C		
SMCOIL D		

OK or NG

- OK >> GO TO 4.
 NG >> GO TO 2.

2. CHECK HARNESS BETWEEN TCM AND STEP MOTOR

1. Turn ignition switch OFF.
2. Disconnect CVT unit connector and TCM connector.
3. Check continuity between TCM connector terminals and CVT unit harness connector terminals.

Item	Connector	Terminal	Continuity
TCM	E31	11	Yes
CVT unit harness connector	F46	6	
TCM	E31	12	Yes
CVT unit harness connector	F46	7	
TCM	E31	20	Yes
CVT unit harness connector	F46	8	
TCM	E31	21	Yes
CVT unit harness connector	F46	9	

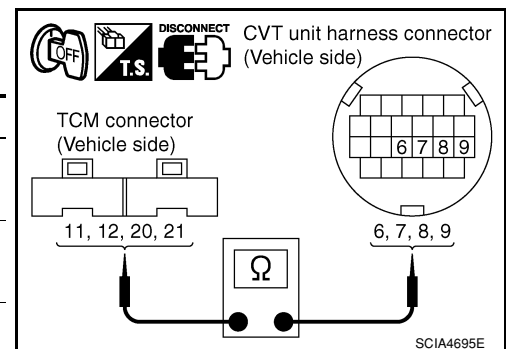

4. If OK, check harness for short to ground and short to power.
5. If OK, check continuity between body ground and CVT assembly.
6. Reinstall any part removed.

OK or NG

- OK >> GO TO 3.
 NG >> Repair open circuit or short to ground or short to power in harness or connectors.

3. CHECK STEP MOTOR

Check step motor. Refer to [CVT-140. "Component Inspection"](#).

OK or NG

- OK >> GO TO 4.
 NG >> Repair or replace damaged parts.

4. CHECK DTC

Perform [CVT-137. "DTC Confirmation Procedure"](#).

OK or NG

- OK >> **INSPECTION END**
 NG >> GO TO 5.

DTC P1777 STEP MOTOR - CIRCUIT

< SERVICE INFORMATION >

5. CHECK TCM

1. Check TCM input/output signals. Refer to [CVT-45. "TCM Terminal and Reference Value"](#).
2. If NG, re-check TCM pin terminals for damage or loose connection with harness connector.

OK or NG

- OK >> **INSPECTION END**
NG >> Repair or replace damaged parts.

Component Inspection

INFOID:000000001703647

STEP MOTOR

1. Turn ignition switch OFF.
2. Disconnect CVT unit harness connector.
3. Check resistance between CVT unit harness connector terminals and ground.

Name	Connector	Terminal	Resistance (Approx.)
Step motor	F46	6 - 7	30 Ω
		8 - 9	
		6 - Ground	15 Ω
		7 - Ground	
		8 - Ground	
		9 - Ground	

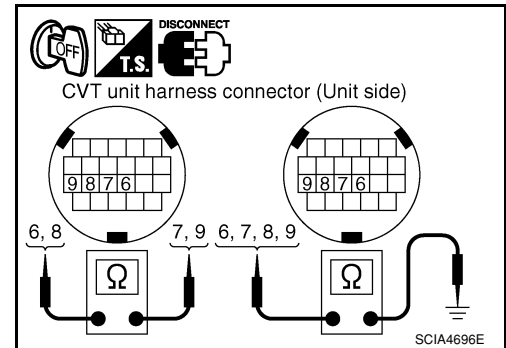

4. If NG, replace the transaxle assembly. Refer to [CVT-178. "Removal and Installation"](#).

DTC P1778 STEP MOTOR - FUNCTION

< SERVICE INFORMATION >

DTC P1778 STEP MOTOR - FUNCTION

Description

INFOID:000000001703648

- The step motor is included in the control valve assembly.
- The step motor's 4 aspects of ON/OFF change according to the signal from TCM. As a result, the flow of line pressure to primary pulley is changed and pulley ratio is controlled.
- This diagnosis item is detected when electrical system is OK, but mechanical system is NG.
- This diagnosis item is detected when the state of the changing the speed mechanism in unit does not operate normally.

CONSULT-III Reference Value in Data Monitor Mode

INFOID:000000001703649

Remarks: Specification data are reference values.

Item name	Condition	Display value (Approx.)
STM STEP	During driving	-20 step - 180 step
GEAR RATIO		2.56 - 0.43

On Board Diagnosis Logic

INFOID:000000001703650

- This is an OBD-II self-diagnostic item.
- Diagnostic trouble code "P1778 STEP MOTR/FNC" with CONSULT-III is detected under the following conditions.
 - When not changing the pulley ratio according to the instruction of TCM.

Possible Cause

INFOID:000000001703651

Step motor

DTC Confirmation Procedure

INFOID:000000001703652

CAUTION:

- **Always drive vehicle at a safe speed.**
- **Before starting "DTC Confirmation Procedure", confirm "Hi" or "Mid" or "Low" fixation by "PRI SPEED" and "VEHICLE SPEED" on "DATA MONITOR MODE".**
- **If hi-gear fixation occurred, go to [CVT-142, "Diagnosis Procedure"](#).**

NOTE:

If "DTC Confirmation Procedure" has been previously performed, always turn ignition switch OFF and wait at least 10 seconds before performing the next test.

After the repair, touch "ERASE" on "SELF-DIAG RESULTS" and then perform the following procedure to confirm the malfunction is eliminated.

① WITH CONSULT-III

1. Turn ignition switch ON and select "DATA MONITOR" mode for "TRANSMISSION" with CONSULT-III.
2. Make sure that output voltage of CVT fluid temperature sensor is within the range below.
ATF TEMP SEN: 1.0 - 2.0 V
If out of range, drive the vehicle to decrease the voltage (warm up the fluid) or stop engine to increase the voltage (cool down the fluid)
3. Select "DATA MONITOR" mode for "TRANSMISSION" with CONSULT-III.
4. Start engine and maintain the following conditions for at least 30 consecutive seconds.
TEST START FROM 0 km/h (0 MPH)
CONSTANT ACCELERATION: Keep 30 sec or more
VEHICLE SPEED: 10 km/h (6 MPH) or more
ACC PEDAL OPEN: More than 1.0/8
RANGE: "D" position
ENG SPEED: 450 rpm or more
5. If DTC is detected, go to [CVT-142, "Diagnosis Procedure"](#).

② WITH GST

Follow the procedure "WITH CONSULT-III".

DTC P1778 STEP MOTOR - FUNCTION

< SERVICE INFORMATION >

Diagnosis Procedure

INFOID:000000001703653

1. CHECK STEP MOTOR

With CONSULT-III

It is monitoring whether "GEAR RATIO: 2.56 - 0.43" changes similarly to "STM STEP: -20 - 180" by DATA MONITOR mode. Refer to [CVT-47, "CONSULT-III Function \(TRANSMISSION\)"](#).

Without CONSULT-III

Inspect the engine speed (rise and descend), vehicle speed, throttle position, and check shift change. Refer to [CVT-181, "Vehicle Speed When Shifting Gears"](#).

OK or NG

OK >> **INSPECTION END**

NG >> Replace the transaxle assembly. Refer to [CVT-178, "Removal and Installation"](#).

OVERDRIVE CONTROL SWITCH

< SERVICE INFORMATION >

OVERDRIVE CONTROL SWITCH

Description

INFOID:000000001703654

- Overdrive control switch is installed to the selector lever.
- O/D OFF indicator turns ON, and overdrive driving activates when pressing the overdrive control switch while driving in "D" position. O/D OFF indicator turns OFF, and "D" position driving starts when pressing the overdrive control switch while driving in the overdrive-off mode. Shifting the selector lever in any position other than "D" releases the overdrive-off mode.

CONSULT-III Reference Value in Data Monitor Mode

INFOID:000000001703655

Item name	Condition	Display value
SPORT MODE SW	While pushing overdrive cancel switch	ON
	Other conditions	OFF

A

B

CVT

D

E

F

G

H

I

J

K

L

M

N

O

P

OVERDRIVE CONTROL SWITCH

< SERVICE INFORMATION >

Wiring Diagram - CVT - ODSW

INFOID:000000001703656

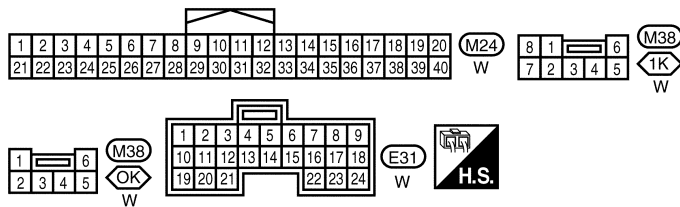
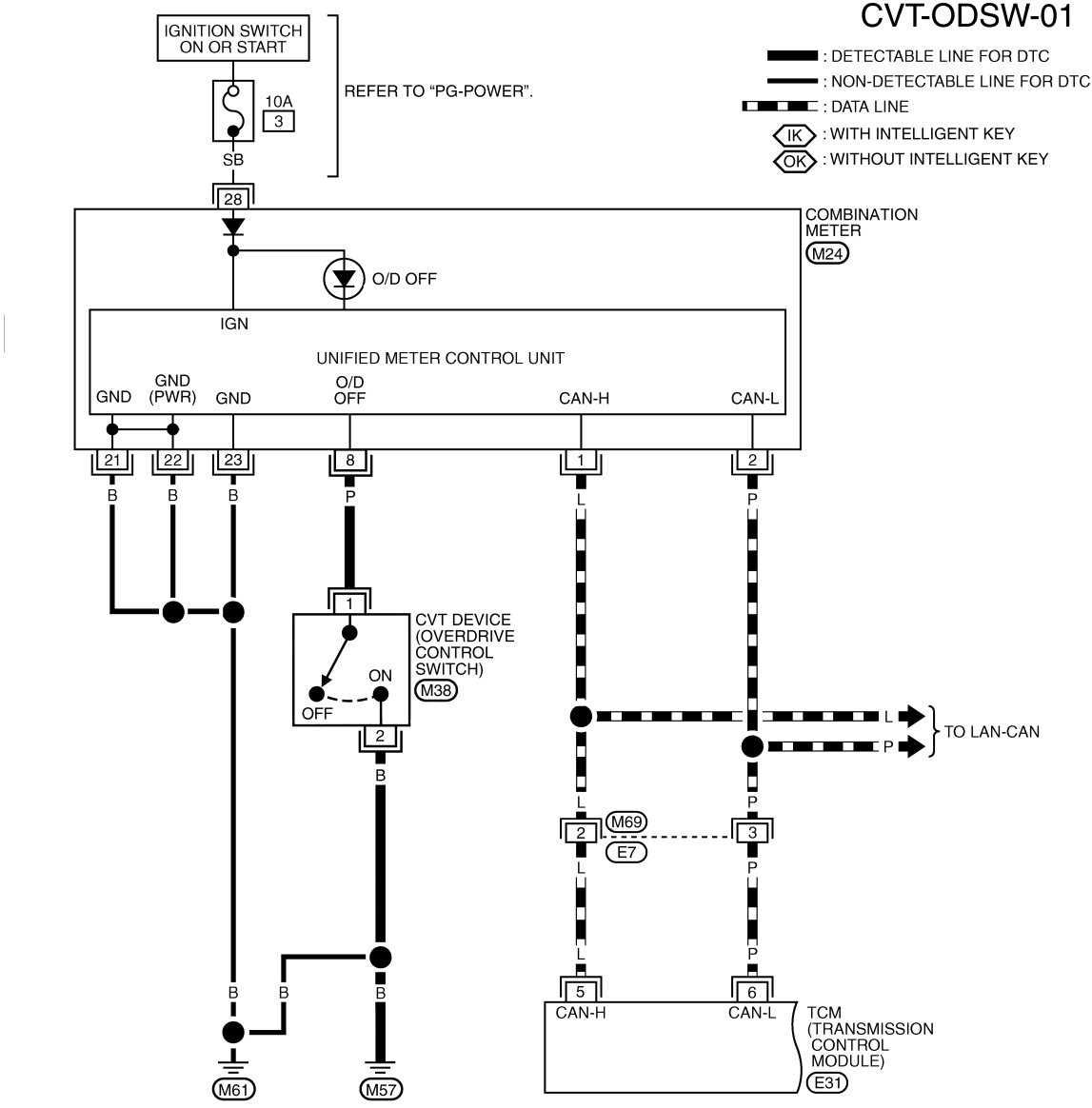

REFER TO THE FOLLOWING.

(M69) -SUPER MULTIPLE JUNCTION (SMJ)

BCWA0686E

TCM TERMINALS AND REFERENCE VALUES

Refer to [CVT-45. "TCM Terminal and Reference Value"](#).

Diagnosis Procedure

INFOID:000000001703657

1. CHECK CAN COMMUNICATION LINE

OVERDRIVE CONTROL SWITCH

< SERVICE INFORMATION >

Perform the self-diagnosis check. Refer to [CVT-47, "CONSULT-III Function \(TRANSMISSION\)"](#).

Is any malfunction of the "U1000 CAN COMM CIRCUIT" indicated in the results?

- YES >> Check CAN communication line. Refer to [CVT-56](#).
- NO >> GO TO 2.

2. CHECK OVERDRIVE CONTROL SWITCH SIGNAL

Ⓜ With CONSULT-III

1. Turn ignition switch ON.
2. Select "ECU INPUT SIGNALS" in "DATA MONITOR" mode for "TRANSMISSION" with CONSULT-III.
3. Read out ON/OFF switching action of the "SPORT MODE SW".

Item name	Condition	Display value
SPORT MODE SW	While pushing overdrive cancel switch	ON
	Other conditions	OFF

OK or NG

- OK >> **INSPECTION END**
- NG >> GO TO 3.

3. CHECK OVERDRIVE CONTROL SWITCH

Check overdrive control switch. Refer to [CVT-146, "Component Inspection"](#)

OK or NG

- OK >> GO TO 4.
- NG >> Repair or replace damaged parts.

4. CHECK SELF-DIAGNOSTIC RESULTS (COMBINATION METER)

Perform self-diagnosis check. Refer to [DI-11, "Self-Diagnosis Mode of Combination Meter"](#).

Is any malfunction detected by self-diagnostic?

- YES >> Check the malfunctioning system.
- NO - 1 >> With intelligent key: GO TO 5.
- NO - 2 >> Without intelligent key: GO TO 6.

5. CHECK OVERDRIVE CONTROL SWITCH CIRCUIT

1. Turn ignition switch OFF.
2. Disconnect CVT device connector and combination meter connector.
3. Check continuity between CVT device harness connector (A) terminal and combination meter harness connector (B) terminal.

Item	Connector	Terminal	Continuity
CVT device harness connector	M38	1	Yes
Combination meter harness connector	M24	8	

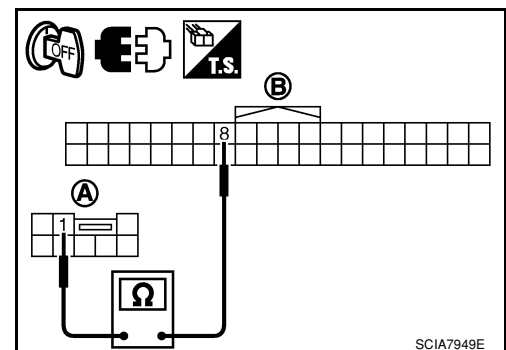

OVERDRIVE CONTROL SWITCH

< SERVICE INFORMATION >

4. Check continuity between CVT device harness connector terminal and ground.

Item	Connector	Terminal	Continuity
CVT device harness connector	M38	2 - ground	Yes

5. If OK, check harness for short to ground and short to power.
6. Reinstall any part removed.

OK or NG

OK >> **INSPECTION END**

NG >> Repair open circuit or short to ground or short to power in harness or connectors.

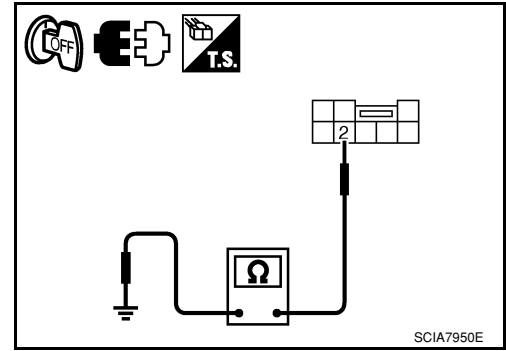

6. CHECK OVERDRIVE CONTROL SWITCH CIRCUIT

1. Turn ignition switch OFF.
2. Disconnect CVT device connector and combination meter connector.
3. Check continuity between CVT device harness connector (A) terminal and combination meter harness connector (B) terminal.

Item	Connector	Terminal	Continuity
CVT device harness connector	M38	1	Yes
Combination meter harness connector	M24	8	

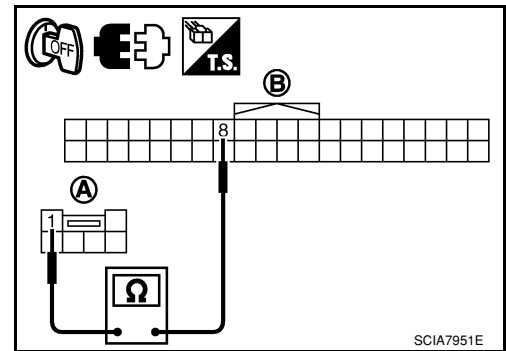

4. Check continuity between CVT device harness connector terminal and ground.

Item	Connector	Terminal	Continuity
CVT device harness connector	M38	2 - ground	Yes

5. If OK, check harness for short to ground and short to power.
6. Reinstall any part removed.

OK or NG

OK >> **INSPECTION END**

NG >> Repair open circuit or short to ground or short to power in harness or connectors.

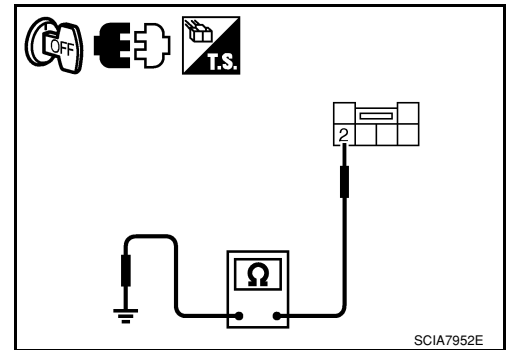

Component Inspection

INFOID:000000001703658

OVERDRIVE CONTROL SWITCH

With Intelligent Key

Check continuity between CVT device harness connector terminals.

Item	Condition	Connector	Terminal	Continuity
Overdrive control switch	While pushing overdrive control switch	M38	1 - 2	Yes
	Other conditions			No

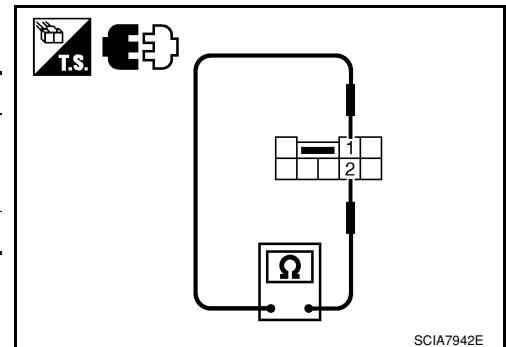

Without Intelligent Key

OVERDRIVE CONTROL SWITCH

< SERVICE INFORMATION >

Check continuity between CVT device harness connector terminals.

Item	Condition	Connector	Terminal	Continuity
Overdrive control switch	While pushing overdrive control switch	M38	1 - 2	Yes
	Other conditions			No

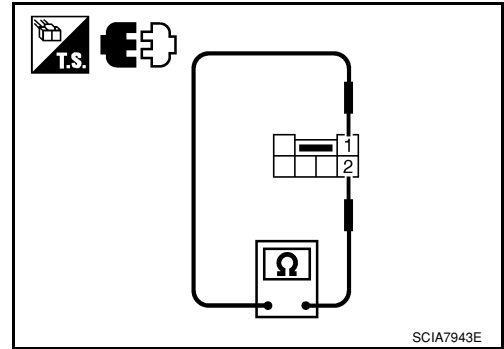

A

B

CVT

D

E

F

G

H

I

J

K

L

M

N

O

P

SHIFT POSITION INDICATOR CIRCUIT

< SERVICE INFORMATION >

SHIFT POSITION INDICATOR CIRCUIT

Description

INFOID:000000001703659

TCM sends the switch signals to combination meter via CAN communication line. Then selector lever position is indicated on the shift position indicator.

CONSULT-III Reference Value in Data Monitor Mode

INFOID:000000001703660

Item name	Condition	Display value
RANGE	Selector lever in "N" or "P" position.	N-P
	Selector lever in "R" position.	R
	Selector lever in "D" position.	D
	Selector lever in "L" position.	L

Diagnosis Procedure

INFOID:000000001703661

1. CHECK INPUT SIGNALS

With CONSULT-III

1. Start engine.
2. Select "MAIN SIGNALS" in "DATA MONITOR" mode for "TRANSMISSION" with CONSULT-III and read out the value of "RANGE".
3. Check that the following three positions or indicators are same.
 - Actual position of the selector lever
 - "RANGE" on CONSULT-III screen
 - Shift position indicator in the combination meter

OK or NG

OK >> **INSPECTION END**

NG >> Check the following.

SHIFT POSITION INDICATOR SYMPTOM CHART

Items	Presumed location of trouble
Actual position does not change.	Park/neutral position switch <ul style="list-style-type: none">• Refer to CVT-65.CVT main system (Fail-safe function actuated)• Refer to CVT-47, "CONSULT-III Function (TRANSMISSION)".
Shift position indicator in the combination meter does not indicate any position.	Perform the self-diagnosis for CVT and the combination meter. <ul style="list-style-type: none">• Refer to CVT-47, "CONSULT-III Function (TRANSMISSION)" and DI-4.
Actual position changes, but the shift position indicator in the combination meter does not change.	
Actual position differs from the shift position indicator in the combination meter.	
Shift position indicator in the combination meter does not indicate specific position only.	Check the combination meter. <ul style="list-style-type: none">• Refer to DI-4.

TROUBLE DIAGNOSIS FOR SYMPTOMS



< SERVICE INFORMATION >

TROUBLE DIAGNOSIS FOR SYMPTOMS

Wiring Diagram - CVT - NONDTC

INFOID:000000001703662

CVT-NONDTC-01

-  : DETECTABLE LINE FOR DTC
-  : NON-DETECTABLE LINE FOR DTC
-  : DATA LINE

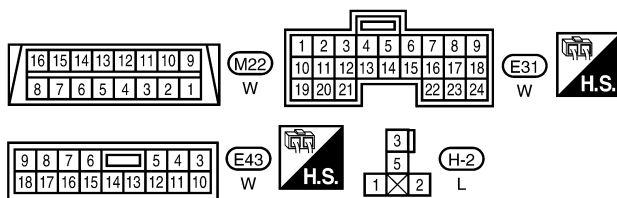
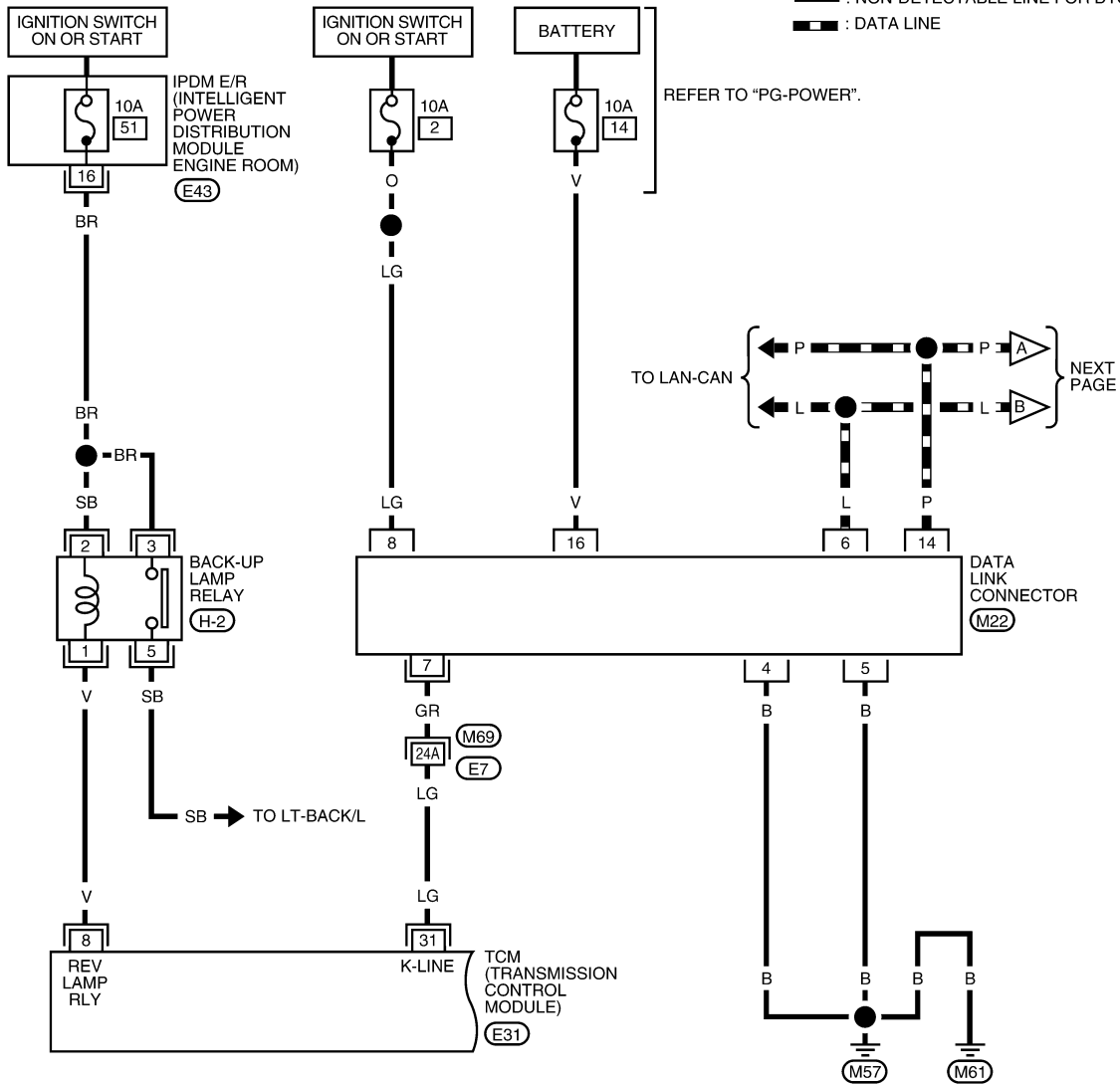

REFER TO THE FOLLOWING.

(M69) - SUPER MULTIPLE JUNCTION (SMJ)

BCWA0682E

TROUBLE DIAGNOSIS FOR SYMPTOMS

< SERVICE INFORMATION >

CVT-NONDTC-02

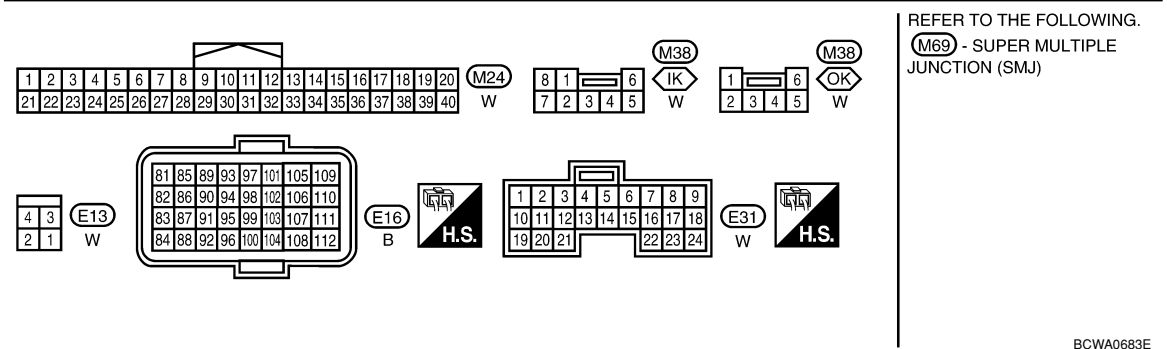
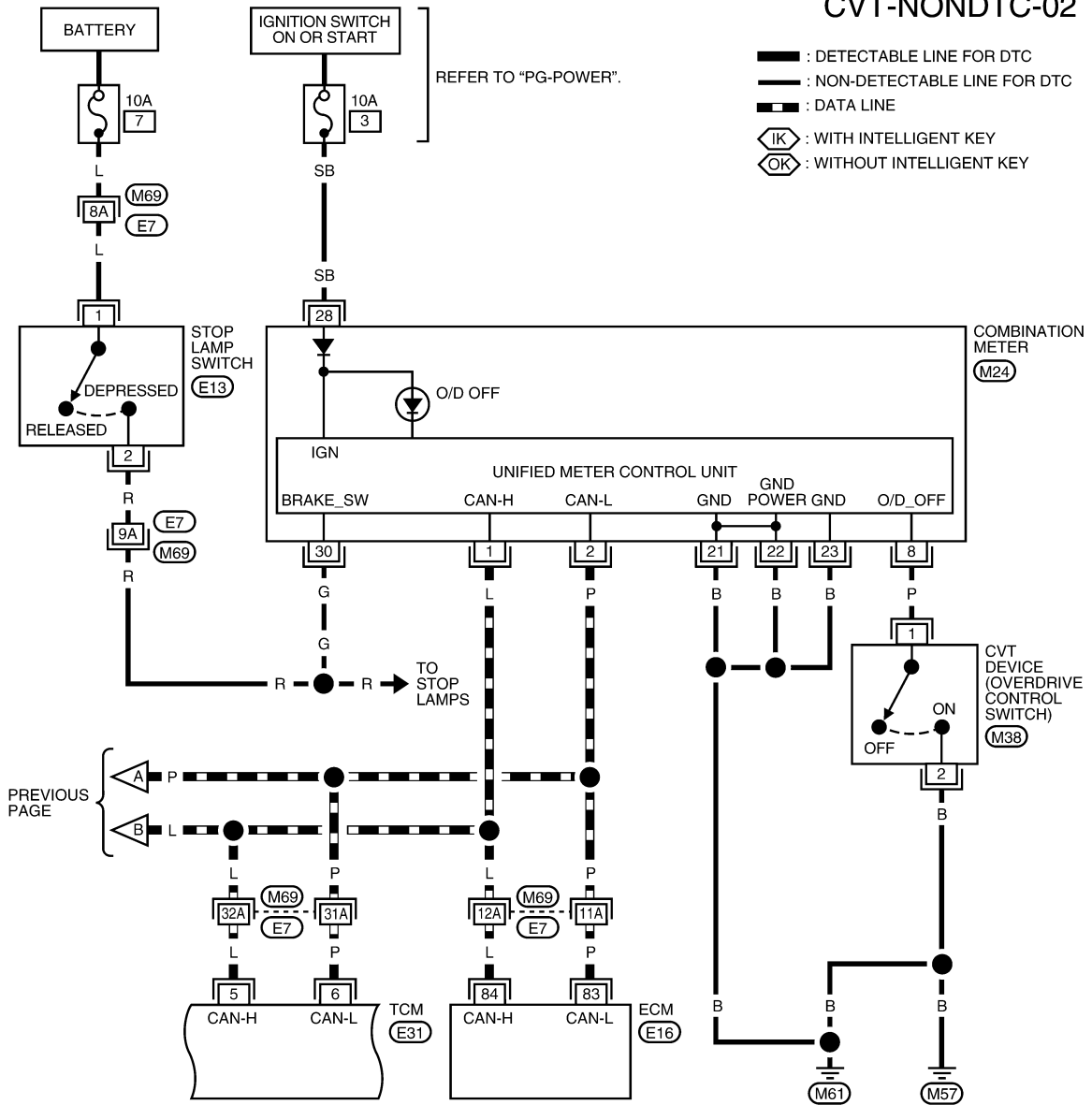

BCWA0683E

TROUBLE DIAGNOSIS FOR SYMPTOMS

< SERVICE INFORMATION >

CVT-NONDTC-03

— : DETECTABLE LINE FOR DTC
 - - - : NON-DETECTABLE LINE FOR DTC

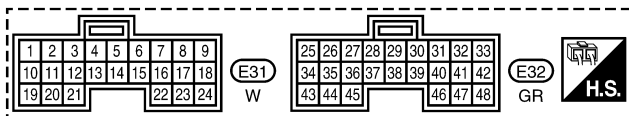
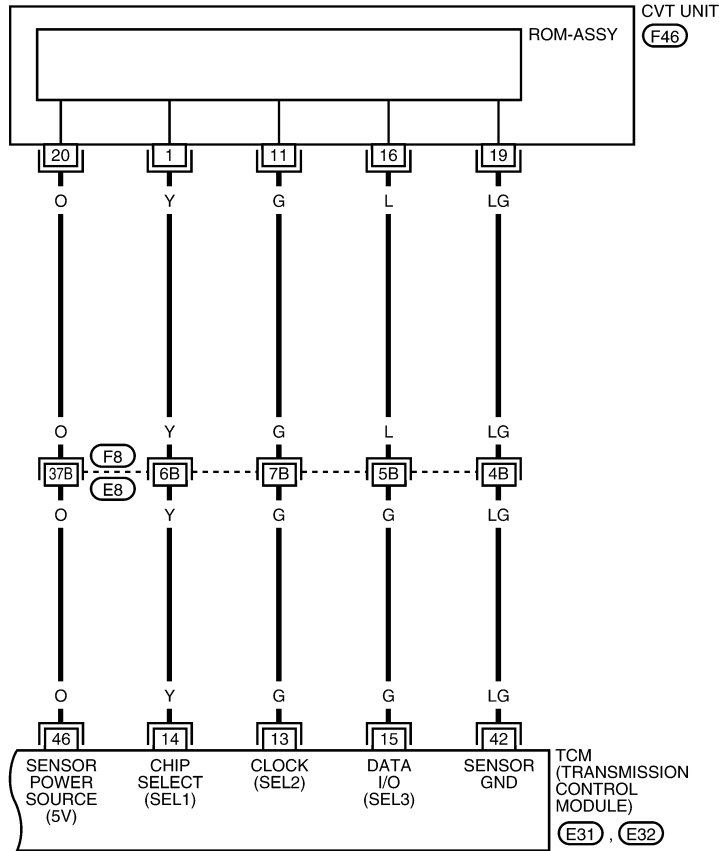

REFER TO THE FOLLOWING.

(F8) - SUPER MULTIPLE JUNCTION (SMJ)

BCWA0684E

TCM TERMINALS AND REFERENCE VALUES

Refer to [CVT-45. "TCM Terminal and Reference Value"](#).

O/D OFF Indicator Lamp Does Not Come On

SYMPTOM:

TROUBLE DIAGNOSIS FOR SYMPTOMS

< SERVICE INFORMATION >

O/D OFF indicator lamp does not come on for about 2 seconds when turning ignition switch ON.

DIAGNOSTIC PROCEDURE

1. CHECK CAN COMMUNICATION LINE

Perform the self-diagnosis check. Refer to [CVT-47, "CONSULT-III Function \(TRANSMISSION\)"](#).

Is any malfunction of the "U1000 CAN COMM CIRCUIT" indicated in the results?

- YES >> Check CAN communication line. Refer to [CVT-56](#).
- NO >> GO TO 2.

2. CHECK TCM POWER SOURCE

1. Turn ignition switch ON.
2. Check voltage between TCM connector terminals and ground. Refer to [CVT-122, "Wiring Diagram - CVT - POWER"](#).

Name	Connector	Terminal	Voltage (Approx.)
Power supply	E31	10	Battery voltage
		19	Battery voltage

OK or NG

- OK >> GO TO 4.
- NG >> GO TO 3.

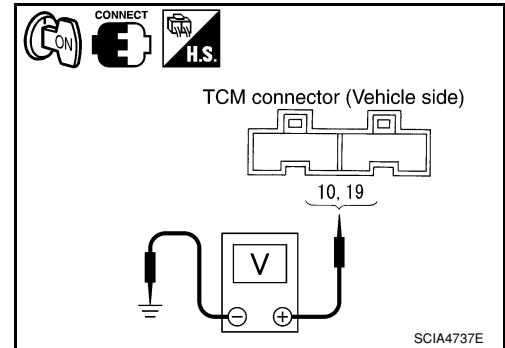

3. DETECT MALFUNCTIONING ITEM

Check the following.

- Harness for short or open between ignition switch and TCM connector terminal 10, 19. Refer to [CVT-122, "Wiring Diagram - CVT - POWER"](#).
- 10 A fuse (No.49, located in the IPDM E/R). Refer to [CVT-122, "Wiring Diagram - CVT - POWER"](#).
- Ignition switch. Refer to [PG-3](#).

OK or NG

- OK >> GO TO 4.
- NG >> Repair or replace damaged parts.

4. CHECK TCM GROUND CIRCUIT

1. Turn ignition switch OFF.
2. Disconnect TCM connector.
3. Check continuity between TCM connector terminals and ground. Refer to [CVT-122, "Wiring Diagram - CVT - POWER"](#).

Name	Connector	Terminal	Continuity
Ground	E32	25	Yes
		48	

OK or NG

- OK >> GO TO 5.
- NG >> Repair open circuit or short to ground or short to power in harness or connectors.

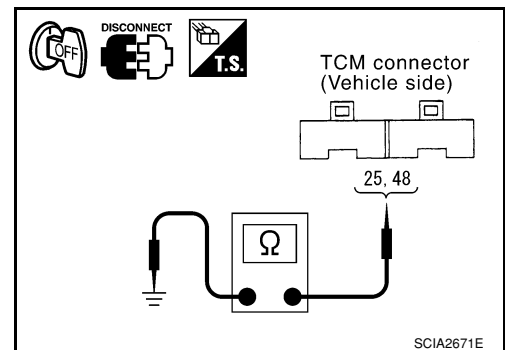

5. DETECT MALFUNCTIONING ITEM

Check the following.

- Harness and fuse for short or open between ignition switch and O/D OFF indicator lamp. Refer to [PG-3](#).

OK or NG

- OK >> GO TO 6.
- NG >> Repair or replace damaged parts.

6. CHECK SYMPTOM

TROUBLE DIAGNOSIS FOR SYMPTOMS

< SERVICE INFORMATION >

Check again. Refer to [CVT-41, "Check before Engine Is Started"](#).

OK or NG

- OK >> **INSPECTION END**
- NG >> GO TO 7.

7.CHECK COMBINATION METERS

Check combination meters. Refer to [DI-4](#)

OK or NG

- OK >> **INSPECTION END**
- NG >> Repair or replace damaged parts.

Engine Cannot Be Started in "P" and "N" Position

INFOID:000000001703664

SYMPTOM:

- Engine cannot be started with selector lever in "P" or "N" position.
- Engine can be started with selector lever in "D", "L" or "R" position.

DIAGNOSTIC PROCEDURE

1.CHECK SELF-DIAGNOSTIC RESULTS

Perform self-diagnosis check. Refer to [CVT-47, "CONSULT-III Function \(TRANSMISSION\)"](#).

Do the self-diagnostic results indicate PNP switch circuit or start signal circuit?

- YES >> Check PNP switch circuit or start signal circuit. Refer to [CVT-65](#) or [CVT-60](#).
- NO >> GO TO 2.

2.CHECK CVT POSITION

Check CVT position. Refer to [CVT-171, "Checking of CVT Position"](#)

OK or NG

- OK >> GO TO 3.
- NG >> Adjust CVT position. Refer to [CVT-171, "Adjustment of CVT Position"](#).

3.CHECK STARTING SYSTEM

Check starting system. Refer to [SC-8](#).

OK or NG

- OK >> **INSPECTION END**
- NG >> Repair or replace damaged parts.

In "P" Position, Vehicle Moves Forward or Backward When Pushed

INFOID:000000001703665

SYMPTOM:

Vehicle moves when it is pushed forward or backward with selector lever in "P" position.

DIAGNOSTIC PROCEDURE

1.CHECK SELF-DIAGNOSTIC RESULTS

Perform self-diagnosis check. Refer to [CVT-47, "CONSULT-III Function \(TRANSMISSION\)"](#).

Do the self-diagnostic results indicate PNP switch circuit?

- YES >> Check PNP switch circuit. Refer to [CVT-65](#).
- NO >> GO TO 2.

2.CHECK CVT POSITION

Check CVT position. Refer to [CVT-171, "Checking of CVT Position"](#)

OK or NG

- OK >> GO TO 3.
- NG >> Adjust CVT position. Refer to [CVT-171, "Adjustment of CVT Position"](#).

3.CHECK SYMPTOM

Check again. Refer to [CVT-41, "Check at Idle"](#).

TROUBLE DIAGNOSIS FOR SYMPTOMS

< SERVICE INFORMATION >

OK or NG

OK >> **INSPECTION END**

NG >> Replace the transaxle assembly. Refer to [CVT-178, "Removal and Installation"](#).

In "N" Position, Vehicle Moves

INFOID:000000001703666

SYMPTOM:

Vehicle moves forward or backward when selecting "N" position.

DIAGNOSTIC PROCEDURE

1. CHECK SELF-DIAGNOSTIC RESULTS

Perform self-diagnosis check. Refer to [CVT-47, "CONSULT-III Function \(TRANSMISSION\)"](#).

Do the self-diagnostic results indicate PNP switch circuit?

YES >> Check PNP switch circuit. Refer to [CVT-65](#).

NO >> GO TO 2.

2. CHECK CVT POSITION

Check CVT position. Refer to [CVT-171, "Checking of CVT Position"](#)

OK or NG

OK >> GO TO 3.

NG >> Adjust CVT position. Refer to [CVT-171, "Adjustment of CVT Position"](#).

3. CHECK CVT FLUID LEVEL

Check CVT fluid level. Refer to [MA-19, "Checking CVT Fluid"](#).

OK or NG

OK >> GO TO 4.

NG >> Refill CVT fluid.

4. CHECK SYMPTOM

Check again. Refer to [CVT-41, "Check at Idle"](#).

OK or NG

OK >> **INSPECTION END**

NG >> GO TO 5.

5. CHECK TCM

1. Check TCM input/output signals. Refer to [CVT-45, "TCM Terminal and Reference Value"](#).

2. If NG, re-check TCM pin terminals for damage or loose connection with harness connector.

OK or NG

OK >> Replace the transaxle assembly. Refer to [CVT-178, "Removal and Installation"](#).

NG >> Repair or replace damaged parts.

Large Shock "N" → "R" Position

INFOID:000000001703667

SYMPTOM:

There is large shock when shifting from "N" to "R" position.

DIAGNOSTIC PROCEDURE

1. CHECK SELF-DIAGNOSTIC RESULTS

Perform self-diagnosis check. Refer to [CVT-47, "CONSULT-III Function \(TRANSMISSION\)"](#).

Is any malfunction detected by self-diagnosis?

YES >> Check the malfunctioning system. Refer to [CVT-47, "CONSULT-III Function \(TRANSMISSION\)"](#).

NO >> GO TO 2.

2. CHECK ENGINE IDLE SPEED

Check the engine idle speed. Refer to [EC-73, "Idle Speed and Ignition Timing Check"](#).

OK or NG

TROUBLE DIAGNOSIS FOR SYMPTOMS

< SERVICE INFORMATION >

- OK >> GO TO 3.
- NG >> Repair.

3.CHECK CVT FLUID LEVEL

Check CVT fluid level. Refer to [MA-19. "Checking CVT Fluid"](#).

OK or NG

- OK >> GO TO 4.
- NG >> Refill CVT fluid.

4.CHECK LINE PRESSURE

Check line pressure at idle. Refer to [CVT-36. "Inspections before Trouble Diagnosis"](#).

OK or NG

- OK >> GO TO 5.
- NG >> Check the malfunctioning item. Refer to [CVT-36. "Inspections before Trouble Diagnosis"](#).

5.SYMPTOM CHECK

Check again. Refer to [CVT-41. "Check at Idle"](#).

OK or NG

- OK >> **INSPECTION END**
- NG >> GO TO 6.

6.CHECK TCM

1. Check TCM input/output signals. Refer to [CVT-45. "TCM Terminal and Reference Value"](#).
2. If NG, re-check TCM pin terminals for damage or loose connection with harness connector.

OK or NG

- OK >> Replace the transaxle assembly. Refer to [CVT-178. "Removal and Installation"](#).
- NG >> Repair or replace damaged parts.

Vehicle Does Not Creep Backward in "R" Position

INFOID:000000001703668

SYMPTOM:

Vehicle does not creep backward when selecting "R" position.

DIAGNOSTIC PROCEDURE

1.CHECK SELF-DIAGNOSTIC RESULTS

Perform self-diagnosis check. Refer to [CVT-47. "CONSULT-III Function \(TRANSMISSION\)"](#).

Is any malfunction detected by self-diagnosis

- YES >> Check the malfunctioning system. Refer to [CVT-47. "CONSULT-III Function \(TRANSMISSION\)"](#).
- NO >> GO TO 2.

2.CHECK CVT POSITION

Check CVT position. Refer to [CVT-171. "Checking of CVT Position"](#)

OK or NG

- OK >> GO TO 3.
- NG >> Adjust CVT position. Refer to [CVT-171. "Adjustment of CVT Position"](#).

3.CHECK CVT FLUID LEVEL

Check CVT fluid level. Refer to [MA-19. "Checking CVT Fluid"](#).

OK or NG

- OK >> GO TO 4.
- NG >> Refill CVT fluid.

4.CHECK LINE PRESSURE

Check line pressure at idle. Refer to [CVT-36. "Inspections before Trouble Diagnosis"](#).

OK or NG

- OK >> GO TO 5.

TROUBLE DIAGNOSIS FOR SYMPTOMS

< SERVICE INFORMATION >

NG >> Check the malfunctioning item. Refer to [CVT-36, "Inspections before Trouble Diagnosis"](#).

5.CHECK STALL REVOLUTION

Check stall revolution. Refer to [CVT-36, "Inspections before Trouble Diagnosis"](#).

OK or NG

OK >> GO TO 6.

NG >> Check the malfunctioning item. Refer to [CVT-36, "Inspections before Trouble Diagnosis"](#).

6.CHECK SYMPTOM

Check again. Refer to [CVT-41, "Check at Idle"](#).

OK or NG

OK >> **INSPECTION END**

NG >> GO TO 7.

7.CHECK TCM

1. Check TCM input/output signals. Refer to [CVT-45, "TCM Terminal and Reference Value"](#).

2. If NG, re-check TCM pin terminals for damage or loose connection with harness connector.

OK or NG

OK >> Replace the transaxle assembly. Refer to [CVT-178, "Removal and Installation"](#).

NG >> Repair or replace damaged parts.

Vehicle Does Not Creep Forward in "D" or "L" Position

INFOID:000000001703669

SYMPTOM:

Vehicle does not creep forward when selecting "D" or "L" position.

DIAGNOSTIC PROCEDURE

1.CHECK SELF-DIAGNOSTIC RESULTS

Perform self-diagnosis check. Refer to [CVT-47, "CONSULT-III Function \(TRANSMISSION\)"](#).

Is any malfunction detected by self-diagnosis?

YES >> Check the malfunctioning system. Refer to [CVT-47, "CONSULT-III Function \(TRANSMISSION\)"](#).

NO >> GO TO 2.

2.CHECK CVT POSITION

Check CVT position. Refer to [CVT-171, "Checking of CVT Position"](#)

OK or NG

OK >> GO TO 3.

NG >> Adjust CVT position. Refer to [CVT-171, "Adjustment of CVT Position"](#).

3.CHECK CVT FLUID LEVEL

Check CVT fluid level. Refer to [MA-19, "Checking CVT Fluid"](#).

OK or NG

OK >> GO TO 4.

NG >> Refill CVT fluid.

4.CHECK LINE PRESSURE

Check line pressure at idle. Refer to [CVT-36, "Inspections before Trouble Diagnosis"](#).

OK or NG

OK >> GO TO 5.

NG >> Check the malfunctioning item. Refer to [CVT-36, "Inspections before Trouble Diagnosis"](#).

5.CHECK STALL REVOLUTION

Check stall revolution. Refer to [CVT-36, "Inspections before Trouble Diagnosis"](#).

OK or NG

OK >> GO TO 6.

NG >> Check the malfunctioning item. Refer to [CVT-36, "Inspections before Trouble Diagnosis"](#).

TROUBLE DIAGNOSIS FOR SYMPTOMS

< SERVICE INFORMATION >

6.CHECK SYMPTOM

Check again. Refer to [CVT-41. "Check at Idle"](#) .

OK or NG

OK >> **INSPECTION END**

NG >> GO TO 7.

7.CHECK TCM

1. Check TCM input/output signals. Refer to [CVT-45. "TCM Terminal and Reference Value"](#) .
2. If NG, re-check TCM pin terminals for damage or loose connection with harness connector.

OK or NG

OK >> Replace the transaxle assembly. Refer to [CVT-178. "Removal and Installation"](#) .

NG >> Repair or replace damaged parts.

Vehicle Speed Does Not Change in "L" Position

INFOID:000000001703670

SYMPTOM:

Vehicle speed does not change in "L" position while the cruise test.

DIAGNOSTIC PROCEDURE

1.CHECK SELF-DIAGNOSTIC RESULTS

Perform self-diagnosis check. Refer to [CVT-47. "CONSULT-III Function \(TRANSMISSION\)"](#) .

Is any malfunction detected by self-diagnosis?

YES >> Check the malfunctioning system. Refer to [CVT-47. "CONSULT-III Function \(TRANSMISSION\)"](#) .

NO >> GO TO 2.

2.CHECK CVT POSITION

Check CVT position. Refer to [CVT-171. "Checking of CVT Position"](#)

OK or NG

OK >> GO TO 3.

NG >> Adjust CVT position. Refer to [CVT-171. "Adjustment of CVT Position"](#) .

3.CHECK CVT FLUID LEVEL

Check CVT fluid level. Refer to [MA-19. "Checking CVT Fluid"](#) .

OK or NG

OK >> GO TO 4.

NG >> Refill CVT fluid.

4.CHECK LINE PRESSURE

Check line pressure at idle. Refer to [CVT-36. "Inspections before Trouble Diagnosis"](#) .

OK or NG

OK >> GO TO 5.

NG >> Check the malfunctioning item. Refer to [CVT-36. "Inspections before Trouble Diagnosis"](#) .

5.CHECK STALL REVOLUTION

Check stall revolution. Refer to [CVT-36. "Inspections before Trouble Diagnosis"](#) .

OK or NG

OK >> GO TO 6.

NG >> Check the malfunctioning item. Refer to [CVT-36. "Inspections before Trouble Diagnosis"](#) .

6.CHECK SYMPTOM

Check again. Refer to [CVT-43. "Cruise Test"](#) .

OK or NG

OK >> **INSPECTION END**

NG >> GO TO 7.

TROUBLE DIAGNOSIS FOR SYMPTOMS

< SERVICE INFORMATION >

7.CHECK TCM

1. Check TCM input/output signals. Refer to [CVT-45, "TCM Terminal and Reference Value"](#) .
2. If NG, re-check TCM pin terminals for damage or loose connection with harness connector.

OK or NG

- OK >> Replace the transaxle assembly. Refer to [CVT-178, "Removal and Installation"](#) .
- NG >> Repair or replace damaged parts.

Vehicle Speed Does Not Change in overdrive-off mode

INFOID:000000001703671

SYMPTOM:

Vehicle speed does not change in overdrive-off mode while the cruise test.

DIAGNOSTIC PROCEDURE

1.CHECK SELF-DIAGNOSTIC RESULTS

Perform self-diagnosis check. Refer to [CVT-47, "CONSULT-III Function \(TRANSMISSION\)"](#) .

Is any malfunction detected by self-diagnosis?

- YES >> Check the malfunctioning system. Refer to [CVT-47, "CONSULT-III Function \(TRANSMISSION\)"](#) .
- NO >> GO TO 2.

2.CHECK OVERDRIVE CONTROL SWITCH

Check overdrive control switch. Refer to [CVT-143](#) .

OK or NG

- OK >> GO TO 3.
- NG >> Repair or replace damaged parts.

3.CHECK CVT FLUID LEVEL

Check CVT fluid level. Refer to [MA-19, "Checking CVT Fluid"](#) .

OK or NG

- OK >> GO TO 4.
- NG >> Refill CVT fluid.

4.CHECK LINE PRESSURE

Check line pressure at idle. Refer to [CVT-36, "Inspections before Trouble Diagnosis"](#) .

OK or NG

- OK >> GO TO 5.
- NG >> Check the malfunctioning item. Refer to [CVT-36, "Inspections before Trouble Diagnosis"](#) .

5.CHECK STALL REVOLUTION

Check stall revolution. Refer to [CVT-36, "Inspections before Trouble Diagnosis"](#) .

OK or NG

- OK >> GO TO 6.
- NG >> Check the malfunctioning item. Refer to [CVT-36, "Inspections before Trouble Diagnosis"](#) .

6.CHECK SYMPTOM

Check again. Refer to [CVT-43, "Cruise Test"](#) .

OK or NG

- OK >> **INSPECTION END**
- NG >> GO TO 7.

7.CHECK TCM

1. Check TCM input/output signals. Refer to [CVT-45, "TCM Terminal and Reference Value"](#) .
2. If NG, re-check TCM pin terminals for damage or loose connection with harness connector.

OK or NG

- OK >> Replace the transaxle assembly. Refer to [CVT-178, "Removal and Installation"](#) .
- NG >> Repair or replace damaged parts.

TROUBLE DIAGNOSIS FOR SYMPTOMS

< SERVICE INFORMATION >

Vehicle Speed Does Not Change in "D" Position

INFOID:000000001703672

SYMPTOM:

Vehicle speed does not change in "D" position while the cruise test.

DIAGNOSTIC PROCEDURE

1. CHECK SELF-DIAGNOSTIC RESULTS

Perform self-diagnosis check. Refer to [CVT-47, "CONSULT-III Function \(TRANSMISSION\)"](#) .

Is any malfunction detected by self-diagnosis?

- YES >> Check the malfunctioning system. Refer to [CVT-47, "CONSULT-III Function \(TRANSMISSION\)"](#) .
- NO >> GO TO 2.

2. CHECK CVT POSITION

Check CVT position. Refer to [CVT-171, "Checking of CVT Position"](#)

OK or NG

- OK >> GO TO 3.
- NG >> Adjust CVT position. Refer to [CVT-171, "Adjustment of CVT Position"](#) .

3. CHECK CVT FLUID LEVEL

Check CVT fluid level. Refer to [MA-19, "Checking CVT Fluid"](#) .

OK or NG

- OK >> GO TO 4.
- NG >> Refill CVT fluid.

4. CHECK LINE PRESSURE

Check line pressure at idle. Refer to [CVT-36, "Inspections before Trouble Diagnosis"](#) .

OK or NG

- OK >> GO TO 5.
- NG >> Check the malfunctioning item. Refer to [CVT-36, "Inspections before Trouble Diagnosis"](#) .

5. CHECK STALL REVOLUTION

Check stall revolution. Refer to [CVT-36, "Inspections before Trouble Diagnosis"](#) .

OK or NG

- OK >> GO TO 6.
- NG >> Check the malfunctioning item. Refer to [CVT-36, "Inspections before Trouble Diagnosis"](#) .

6. CHECK SYMPTOM

Check again. Refer to [CVT-43, "Cruise Test"](#) .

OK or NG

- OK >> **INSPECTION END**
- NG >> GO TO 7.

7. CHECK TCM

1. Check TCM input/output signals. Refer to [CVT-45, "TCM Terminal and Reference Value"](#) .
2. If NG, re-check TCM pin terminals for damage or loose connection with harness connector.

OK or NG

- OK >> Replace the transaxle assembly. Refer to [CVT-178, "Removal and Installation"](#) .
- NG >> Repair or replace damaged parts.

Vehicle Does Not Decelerate by Engine Brake

INFOID:000000001703673

SYMPTOM:

Engine brake does not operate when releasing the accelerator pedal while the cruise test.

DIAGNOSTIC PROCEDURE

1. CHECK SELF-DIAGNOSTIC RESULTS

A
B
CVT
D
E
F
G
H
I
J
K
L
M
N
O
P

TROUBLE DIAGNOSIS FOR SYMPTOMS

< SERVICE INFORMATION >

Perform self-diagnosis check. Refer to [CVT-47. "CONSULT-III Function \(TRANSMISSION\)"](#) .

Is any malfunction detected by self-diagnosis?

- YES >> Check the malfunctioning system. Refer to [CVT-47. "CONSULT-III Function \(TRANSMISSION\)"](#) .
- NO >> GO TO 2.

2.CHECK CVT POSITION

Check CVT position. Refer to [CVT-171. "Checking of CVT Position"](#)

OK or NG

- OK >> GO TO 3.
- NG >> Adjust CVT position. Refer to [CVT-171. "Adjustment of CVT Position"](#) .

3.CHECK CVT FLUID LEVEL

Check CVT fluid level. Refer to [MA-19. "Checking CVT Fluid"](#) .

OK or NG

- OK >> GO TO 4.
- NG >> Refill CVT fluid.

4.CHECK LINE PRESSURE

Check line pressure at idle. Refer to [CVT-36. "Inspections before Trouble Diagnosis"](#) .

OK or NG

- OK >> GO TO 5.
- NG >> Check the malfunctioning item. Refer to [CVT-36. "Inspections before Trouble Diagnosis"](#) .

5.CHECK SYMPTOM

Check again. Refer to [CVT-43. "Cruise Test"](#) .

OK or NG

- OK >> **INSPECTION END**
- NG >> GO TO 6.

6.CHECK TCM

1. Check TCM input/output signals. Refer to [CVT-45. "TCM Terminal and Reference Value"](#) .
2. If NG, re-check TCM pin terminals for damage or loose connection with harness connector.

OK or NG

- OK >> Replace the transaxle assembly. Refer to [CVT-178. "Removal and Installation"](#) .
- NG >> Repair or replace damaged parts.

TRANSMISSION CONTROL MODULE

< SERVICE INFORMATION >

TRANSMISSION CONTROL MODULE

Removal and Installation

INFOID:000000001703674

COMPONENTS

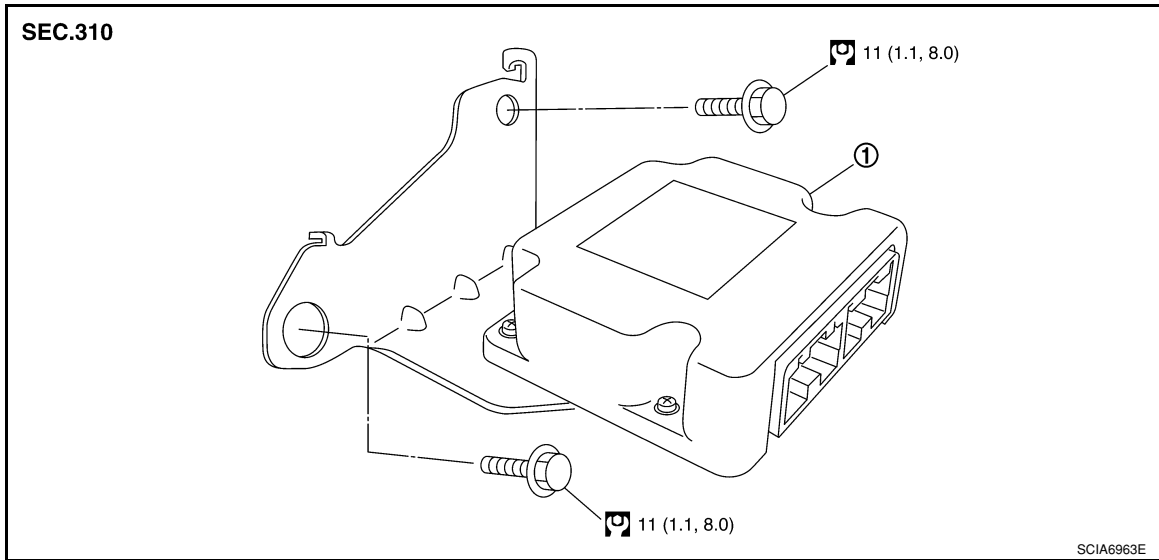

1. TCM

REMOVAL

1. Disconnect the battery negative terminal.
2. Disconnect the TCM harness connector (1) from the TCM (2).
 - Instrument lower finisher (3)
3. Remove the TCM (2).

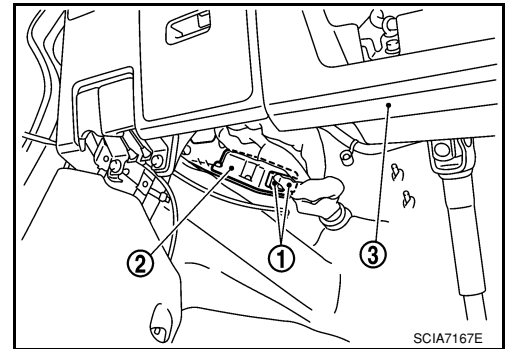

INSTALLATION

Installation is in the reverse order of removal.

A

B

CVT

D

E

F

G

H

I

J

K

L

M

N

O

P

CVT SHIFT LOCK SYSTEM

< SERVICE INFORMATION >

CVT SHIFT LOCK SYSTEM

Description

INFOID:000000001703675

- The mechanical key interlock mechanism also operates as a shift lock:
With the ignition switch turned to ON, selector lever cannot be shifted from "P" position to any other position unless brake pedal is depressed.
With the key removed, selector lever cannot be shifted from "P" position to any other position.
The key cannot be removed unless selector lever is placed in "P" position.
- The shift lock and key interlock mechanisms are controlled by the ON-OFF operation of the shift lock solenoid and by the operation of the rotator and slider located inside key cylinder, respectively.

Shift Lock System Electrical Parts Location

INFOID:000000001703676

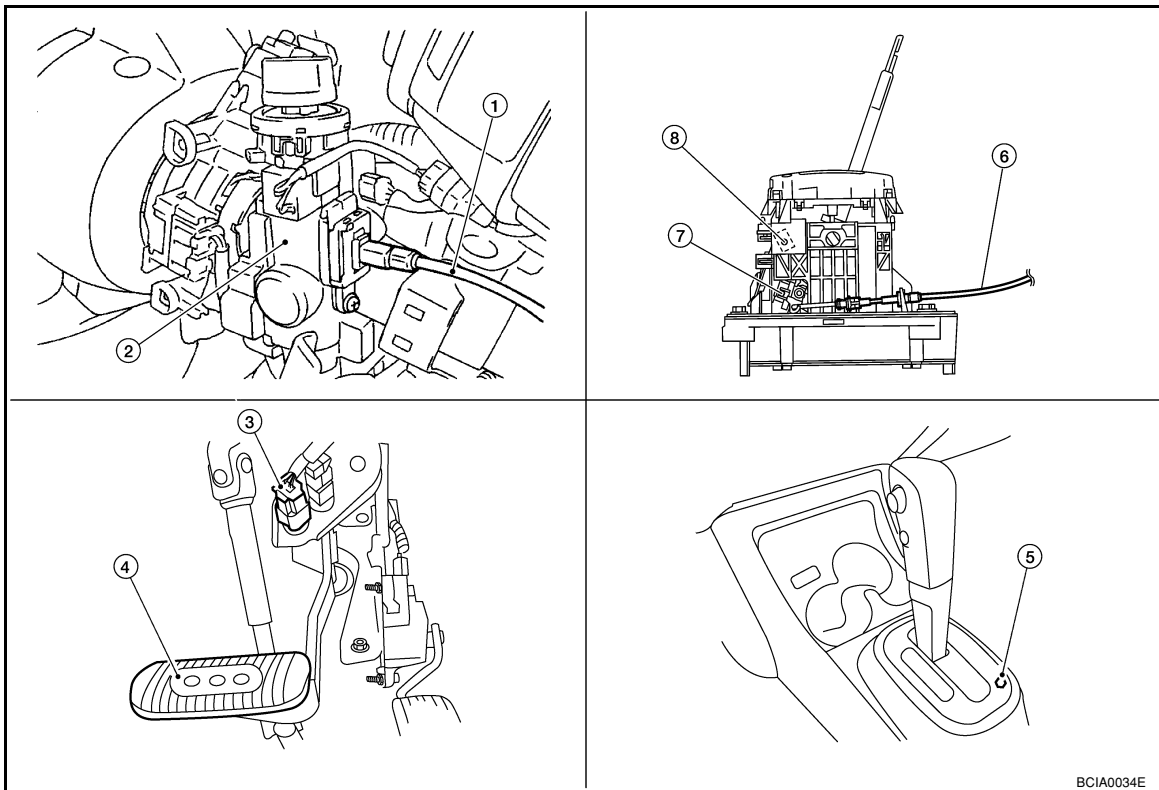

1. Key interlock cable
4. Brake pedal
7. Shift lock solenoid

2. Key cylinder
5. Shift lock release button
8. Park position switch

3. Stop lamp switch
6. Key interlock cable

CVT SHIFT LOCK SYSTEM

< SERVICE INFORMATION >

Wiring Diagram - CVT - SHIFT

INFOID:000000001703678

A
B
C
D
E
F
G
H
I
J
K
L
M
N
O
P

CVT

CVT-SHIFT-01

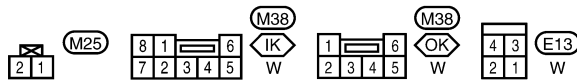
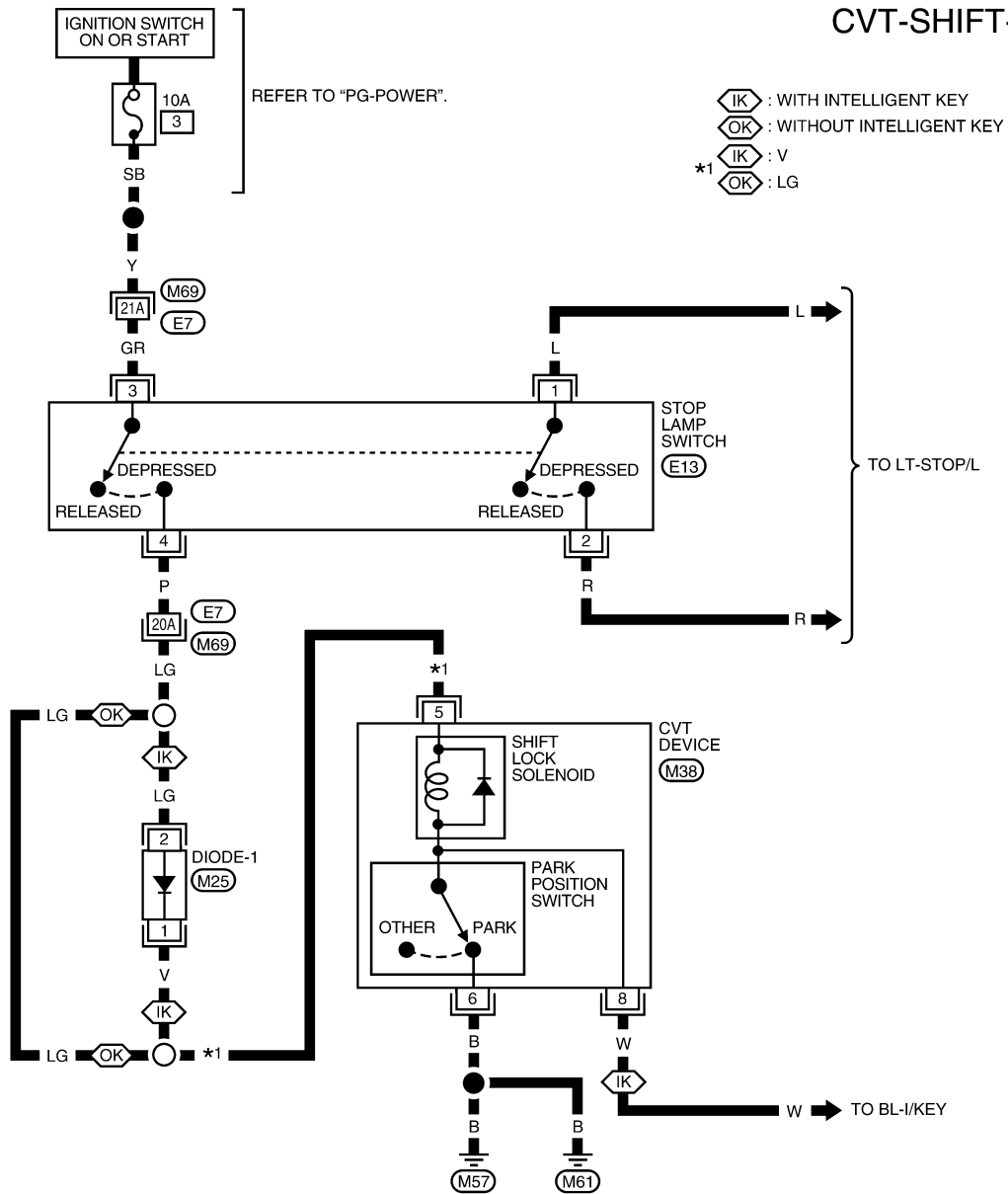

REFER TO THE FOLLOWING.
M69 - SUPER MULTIPLE JUNCTION (SMJ)

BCWA0685E

Diagnosis Procedure

INFOID:000000001703678

SYMPTOM 1:

- Selector lever cannot be moved from "P" position with ignition switch in ON position and brake pedal depressed.

CVT SHIFT LOCK SYSTEM

< SERVICE INFORMATION >

- Selector lever can be moved from “P” position with ignition key in ON position and brake pedal released.
- Selector lever can be moved from “P” position when ignition switch is removed from key cylinder.

SYMPTOM 2:

- Ignition key cannot be removed when selector lever is set to “P” position.
- Ignition key can be removed when selector lever is set to any position except “P” position.

1. CHECK KEY INTERLOCK CABLE

Check key interlock cable for damage.

OK or NG

- OK >> GO TO 2.
- NG >> Repair key interlock cable. Refer to [AT-213. "Removal and Installation"](#).

2. CHECK CVT POSITION

Check CVT position. Refer to [CVT-171. "Checking of CVT Position"](#).

OK or NG

- OK >> GO TO 3.
- NG >> Adjust control cable. Refer to [CVT-171. "Adjustment of CVT Position"](#).

3. CHECK SHIFT LOCK SOLENOID AND PARK POSITION SWITCH

1. Turn ignition switch ON. (Do not start engine.)
2. Selector lever is set in “P” position.
3. Check operation sound.

Condition	Brake pedal	Operation sound
When ignition switch is turned to ON position and selector lever is set in “P” position.	Depressed	Yes
	Released	No

OK or NG

- OK >> **INSPECTION END**
- NG - 1 >> With intelligent key: GO TO 4.
- NG - 2 >> Without intelligent key: GO TO 5.

4. CHECK POWER SOURCE

1. Turn ignition switch ON. (Do not start engine.)
2. Check voltage between CVT device harness connector terminal 5 and ground.

Voltage:

Brake pedal depressed: Battery voltage

Brake pedal released: 0V

OK or NG

- OK >> GO TO 8.
- NG >> GO TO 6.

5. CHECK POWER SOURCE

1. Turn ignition switch ON. (Do not start engine.)

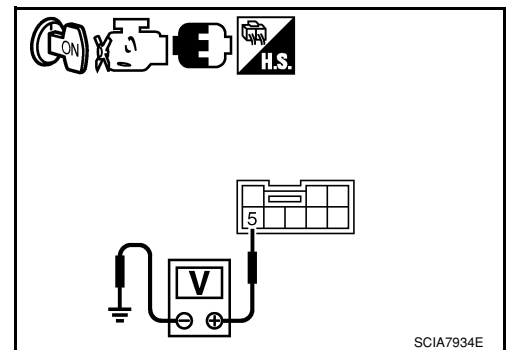

CVT SHIFT LOCK SYSTEM

< SERVICE INFORMATION >

- Check voltage between CVT device harness connector terminal 5 and ground.

Voltage:

Brake pedal depressed: Battery voltage

Brake pedal released: 0V

OK or NG

- OK >> GO TO 9.
NG >> GO TO 6.

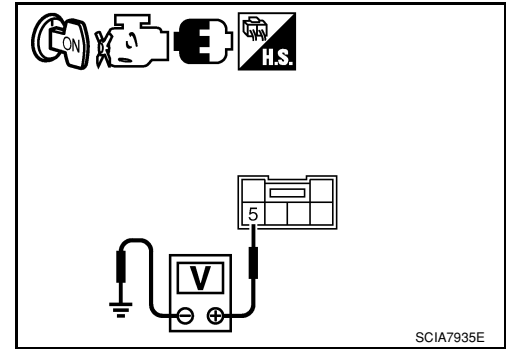

6. CHECK STOP LAMP SWITCH

- Turn ignition switch OFF.
- Disconnect stop lamp switch harness connector.
- Check continuity between stop lamp switch harness connector terminals 3 and 4.

Condition	Continuity
When brake pedal is depressed	Yes
When brake pedal is released	No

Check stop lamp switch after adjusting brake pedal. Refer to BR-5.

OK or NG

- OK >> GO TO 7.
NG >> Repair or replace damaged parts.

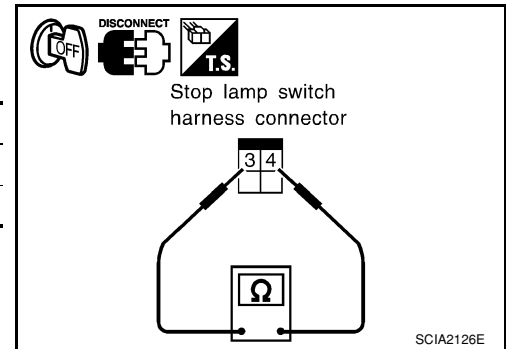

7. DETECT MALFUNCTIONING ITEM

Check the following. If any items are damaged, repair or replace damaged parts.

- Harness for short or open between ignition switch and stop lamp switch harness connector
- Harness for short or open between stop lamp switch harness connector and CVT device harness connector
- 10A fuse [No.3, located in the fuse block (J/B)]
- Ignition switch, Refer to PG-3.

OK or NG

- OK >> **INSPECTION END**
NG >> Repair or replace damaged parts.

8. CHECK GROUND CIRCUIT

- Turn ignition switch OFF.
- Disconnect CVT device harness connector.
- Check continuity between CVT device harness connector terminal 6 and ground.

Continuity should exist.

- Connect CVT device harness connector.

OK or NG

- OK >> Replace shift lock solenoid and park position switch assembly.
NG >> Repair open circuit or short to ground or short to power in harness or connectors.

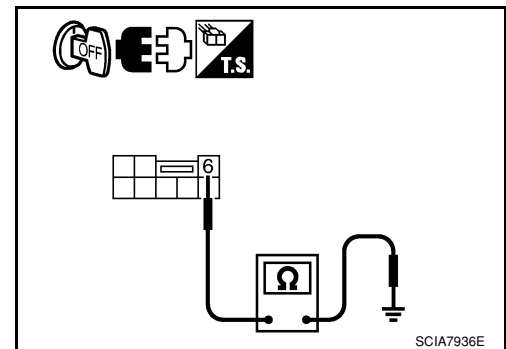

9. CHECK GROUND CIRCUIT

- Turn ignition switch OFF.
- Disconnect CVT device harness connector.

CVT SHIFT LOCK SYSTEM

< SERVICE INFORMATION >

3. Check continuity between CVT device harness connector terminal 6 and ground.

Continuity should exist.

4. Connect CVT device harness connector.

OK or NG

- OK >> Replace shift lock solenoid and park position switch assembly.
- NG >> Repair open circuit or short to ground or short to power in harness or connectors.

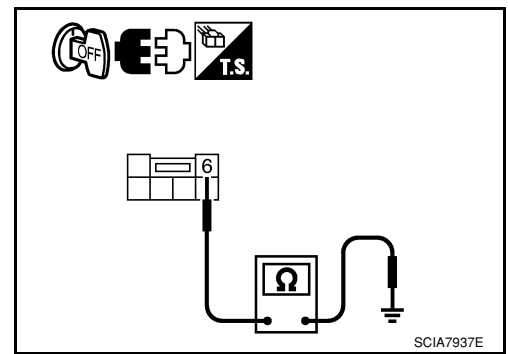

SHIFT CONTROL SYSTEM

< SERVICE INFORMATION >

SHIFT CONTROL SYSTEM

Removal and Installation

INFOID:000000001703679

CONTROL DEVICE COMPONENTS

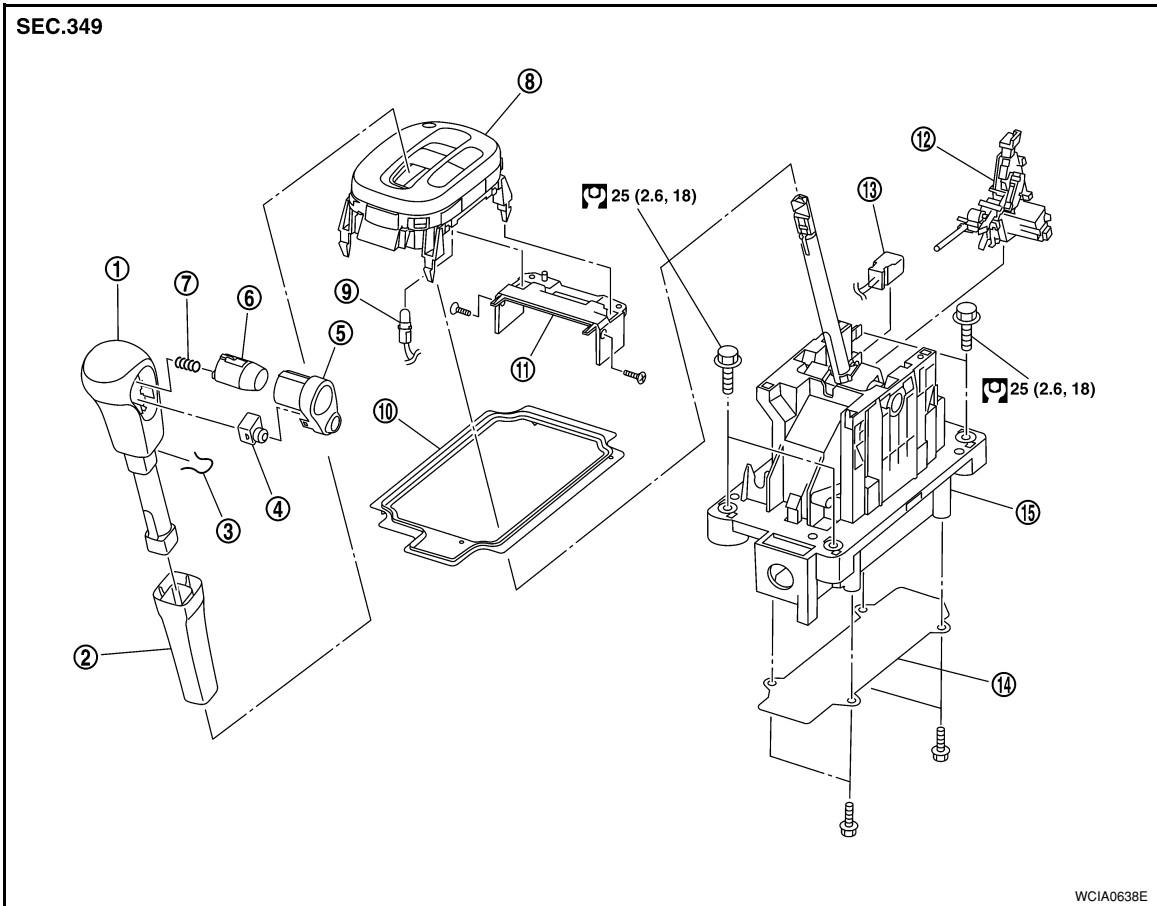

- | | | |
|----------------------------------|-----------------------------|---|
| 1. Selector lever knob | 2. Knob cover | 3. Lock pin |
| 4. Overdrive control switch | 5. Knob finisher | 6. Selector button |
| 7. Selector button return spring | 8. Position indicator plate | 9. Position lamp |
| 10. Dust cover | 11. Bracket | 12. Shift lock solenoid and park position switch assembly |
| 13. CVT device harness connector | 14. Plate | 15. Control device assembly |

CONTROL CABLE COMPONENTS

Refer to the figure below for control cable removal and installation procedure.

SHIFT CONTROL SYSTEM

< SERVICE INFORMATION >

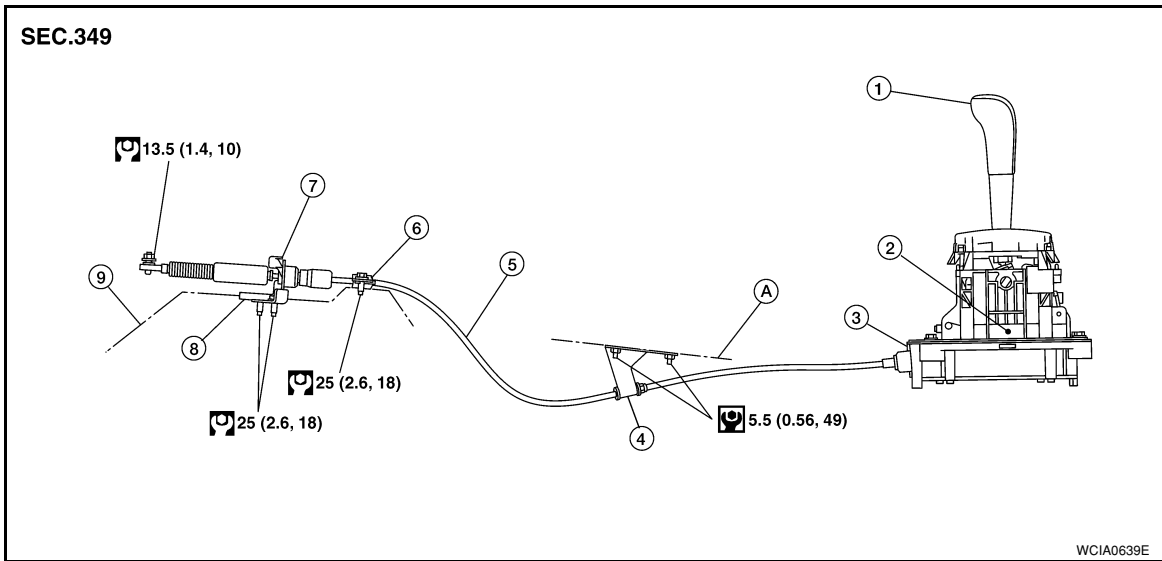

- | | | |
|------------------------|----------------------------|-----------------------|
| 1. Selector lever knob | 2. Control device assembly | 3. Lock plate |
| 4. Bracket | 5. Control cable | 6. Bracket |
| 7. Lock plate | 8. Bracket | 9. Transaxle assembly |
| A. Floor | | |

REMOVAL

CAUTION:

Make sure that parking brake is applied before removal and installation.

1. Place the selector lever in the "N" position.
2. Remove the center console assembly. Refer to [IP-10](#).
3. Disconnect the CVT device harness connector (1).
4. Remove the key interlock cable from the control device assembly. Refer to [CVT-173. "Removal and Installation"](#).

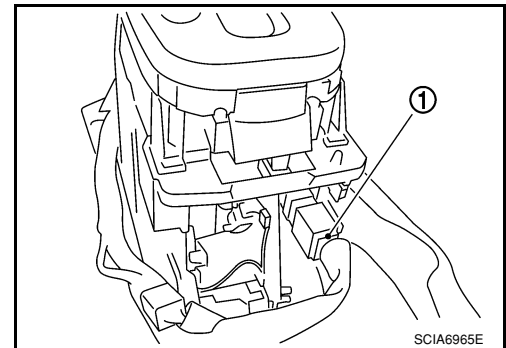

5. Remove the bolts (A) from the control device assembly (1).
6. Remove exhaust front tube, center muffler and heat plates. Refer to [EM-21](#).

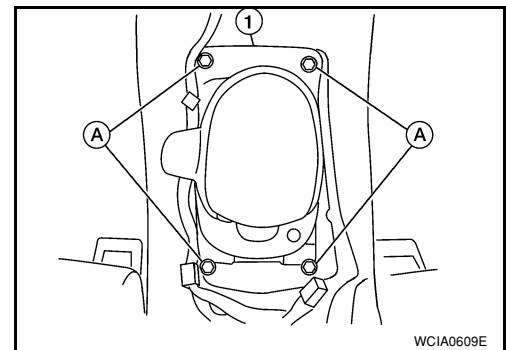

SHIFT CONTROL SYSTEM

< SERVICE INFORMATION >

7. Remove the plate (1) from the control device assembly.

⇐: Vehicle front

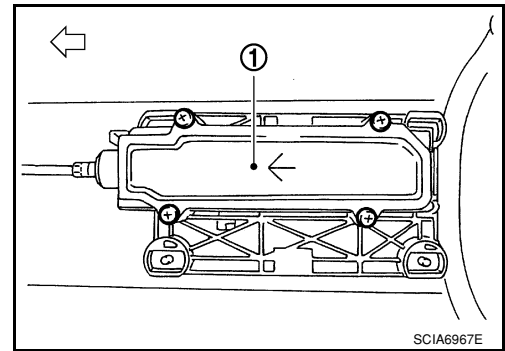

8. Remove the lock plate (1) from the control cable (2).

⇐: Vehicle front

9. Remove the control cable (2) from the control device assembly.

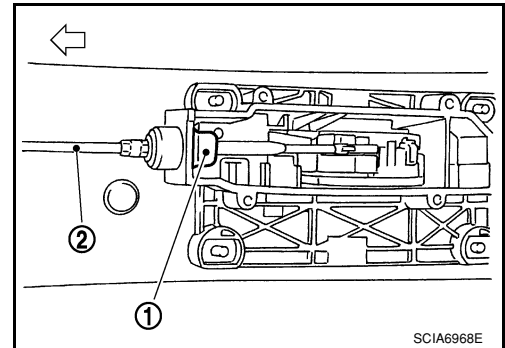

10. Insert flat-bladed screwdrivers at points (A) and (B) as shown, and press both tabs (E) and (F) at the front (C) and rear (D) slightly toward the center of the control device assembly to remove the control device assembly from the underside of the vehicle.

⇐: Vehicle front

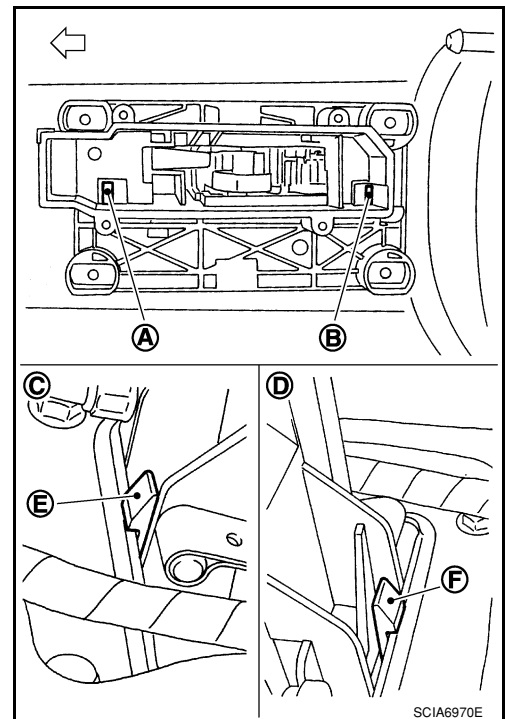

INSTALLATION

Installation is in the reverse order of removal.

A
B
CVT
D
E
F
G
H
I
J
K
L
M
N
O
P

SHIFT CONTROL SYSTEM

< SERVICE INFORMATION >

- When installing the control cable (1) to the control device assembly (2), make sure that the control cable (1) is fully pressed in with the ribbed surface (A) facing downward from the vehicle.

⇐: Vehicle front

- After installation is completed, adjust and check the CVT position. Refer to [CVT-171. "Adjustment of CVT Position"](#) and [CVT-171. "Checking of CVT Position"](#).

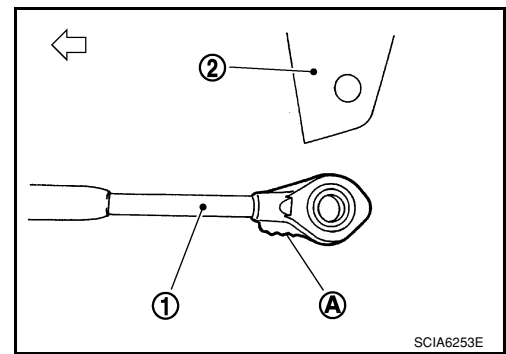

Control Device Disassembly and Assembly

INFOID:000000001703680

DISASSEMBLY

NOTE:

Refer to [CVT-167. "Removal and Installation"](#) to disassemble.

1. Remove selector lever knob from control device assembly. Refer to [CVT-170. "Selector Lever Knob Removal and Installation"](#).
2. Remove position lamp from position indicator plate (1).
3. Insert a flat-bladed screwdriver to (A) (at 4 locations) as shown, and bend each hook slightly to raise position indicator plate (1) and remove from control device assembly (2).
4. Remove bracket from control device assembly (2).
5. Remove CVT device harness connector from control device assembly (2).
6. Release tabs (A) on shift lock solenoid and park position switch assembly from hooks (B) on control device assembly to shift lock solenoid and park position switch assembly.

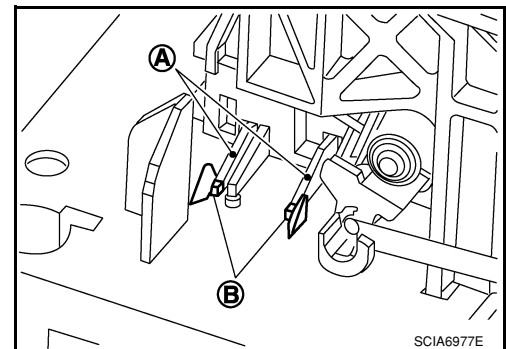
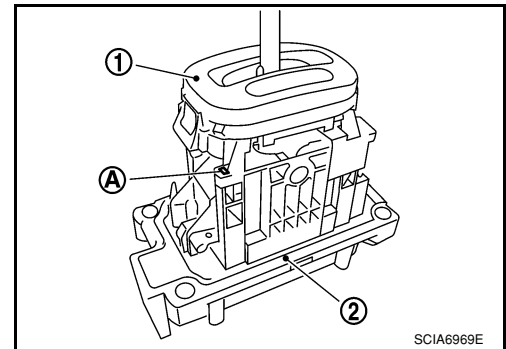

ASSEMBLY

Assembly is in the reverse order of disassembly.

Selector Lever Knob Removal and Installation

INFOID:000000001703681

REMOVAL

CAUTION:

Make sure that parking brake is applied before removal/installation.

SHIFT CONTROL SYSTEM

< SERVICE INFORMATION >

1. Set selector lever knob (1) in "N" position.
2. Slide knob cover (2) downward.
3. Pull out lock pin (3) from selector lever knob (1).
4. Remove selector lever knob (1) and knob cover (2) as a set from selector lever.

CAUTION:

Do not push selector button.

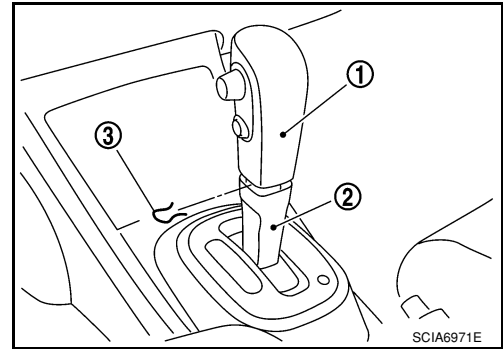

INSTALLATION

1. Insert lock pin (1) to selector lever knob (2).
2. Install knob cover (3) to selector lever knob (2).
3. Set selector lever in "N" position.
4. Install selector lever knob over selector lever until a click is felt.

CAUTION:

- Do not tilt selector lever knob when installing. Install it straight, and do not tap or apply any shock to install it.
- Do not push selector button.

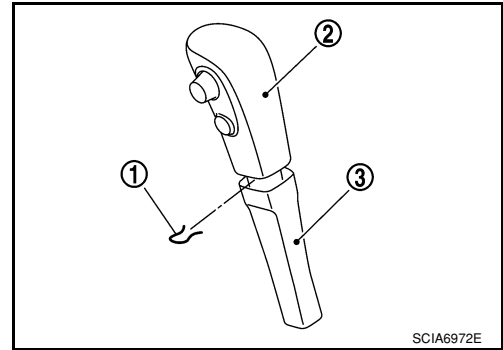

Adjustment of CVT Position

INFOID:000000001703682

CAUTION:

Make sure that parking brake is applied before adjustment.

1. Loosen the control cable nut (A) and place the manual lever (1) in "P" position.
2. Place selector lever in "P" position.
3. Push the control cable (2) in with a load of 9.8 N (approximately 1 kg, 2.2 lb). Release the control cable and temporarily tighten the control cable nut.

NOTE:

Do not move the manual lever. Make sure the manual lever stays in the "P" position.

4. Tighten the control cable nut.

CAUTION:

Secure the manual lever when tightening nut.

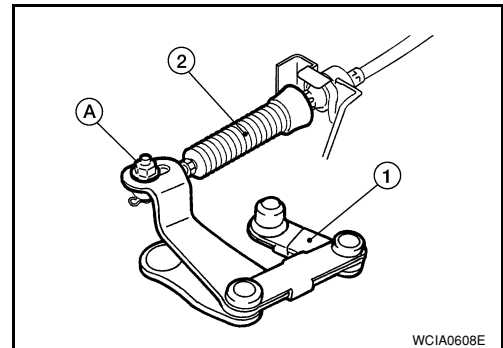

Control cable nut: Refer to [CVT-167, "Removal and Installation"](#).

5. Check the operation of the CVT. Refer to [CVT-171, "Checking of CVT Position"](#).

Checking of CVT Position

INFOID:000000001703683

1. Place selector lever in "P" position, and turn ignition switch ON. (Do not start engine.)
2. Make sure selector lever can be shifted to other than "P" position when brake pedal is depressed. Also make sure selector lever can be shifted from "P" position only when brake pedal is depressed.
3. Move the selector lever and check for excessive effort, sticking, noise or rattle.
4. Confirm the selector lever stops at each position with the feel of engagement when it is moved through all the positions. Check that the actual position of the selector lever matches the position shown by the shift position indicator and the manual lever on the transaxle.

SHIFT CONTROL SYSTEM

< SERVICE INFORMATION >

5. The method of operating the selector lever to individual positions correctly should be as shown.
 - (A): Press selector button to operate selector lever, while depressing the brake pedal.
 - (B): Press selector button to operate selector lever.
 - (C): Selector lever can be operated without pressing selector button.
6. Confirm the back-up lamps illuminate only when selector lever is placed in the “R” position. Confirm the back-up lamps do not illuminate when the selector lever is pushed toward the “R” position side with the gear position remained in the “P” or “N” position.
7. Confirm the engine can only be started with the selector lever in the “P” and “N” positions.
8. Make sure transaxle is locked completely in “P” position.

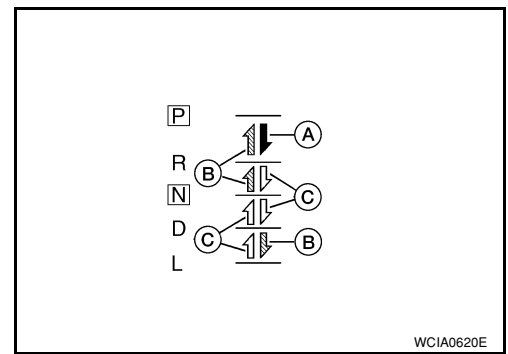

KEY INTERLOCK CABLE

< SERVICE INFORMATION >

KEY INTERLOCK CABLE

Removal and Installation

INFOID:000000001703684

COMPONENTS

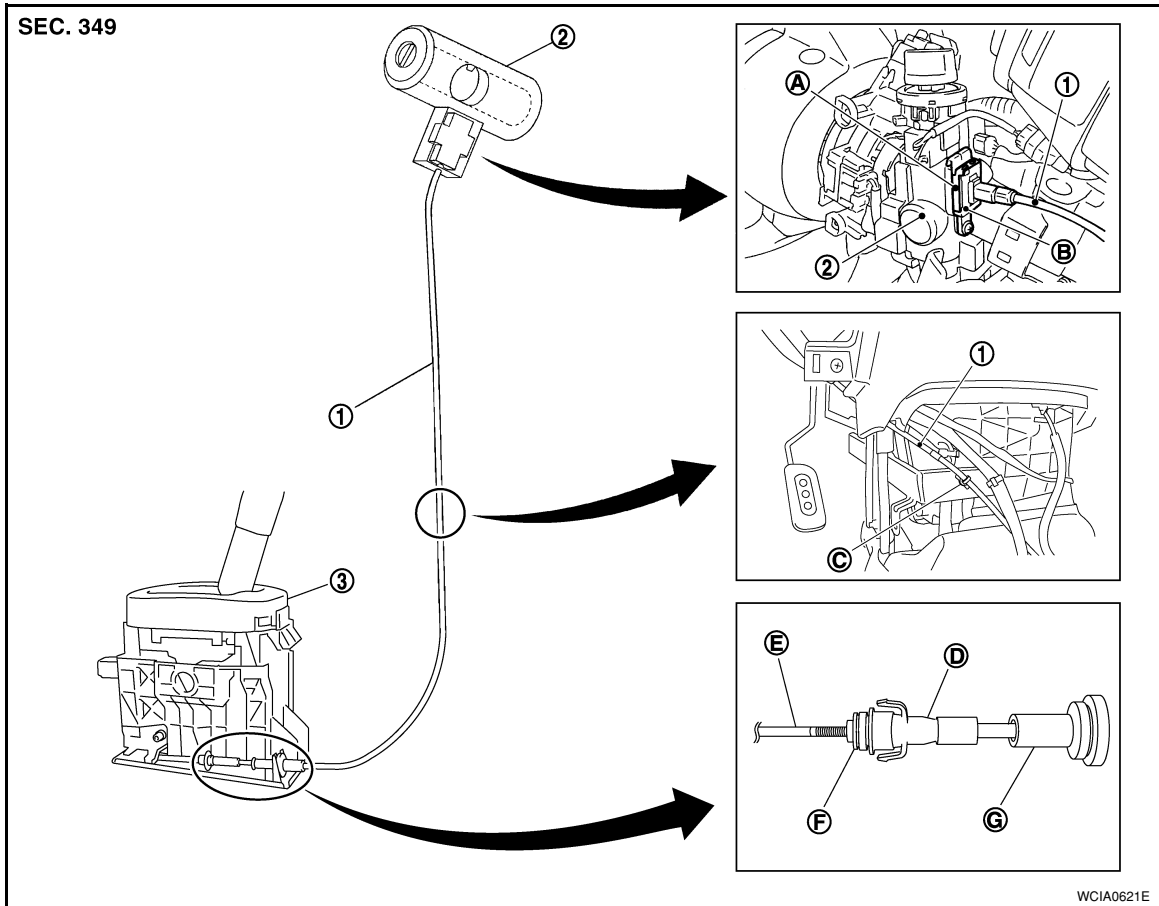

- | | | |
|------------------------|----------------------|----------------------------|
| 1. Key interlock cable | 2. Key cylinder | 3. Control device assembly |
| A. Lock plate | B. Holder | C. Clip |
| D. Slider | E. Key interlock rod | F. Adjust holder |
| G. Casing cap | | |

REMOVAL

Refer to the figure for key interlock cable removal procedure.

CAUTION:

Make sure that parking brake is applied before removal/installation.

1. Place the selector lever in the "N" position.
2. Remove the selector lever knob. Refer to [CVT-170, "Selector Lever Knob Removal and Installation"](#).
3. Remove the center console assembly. Refer to [IP-10](#).

KEY INTERLOCK CABLE

< SERVICE INFORMATION >

- Slide the slider (A) toward the casing cap (B) while pressing tabs (C) on the slider to separate the slider (A) from the adjust holder (D).
- Remove the casing cap (B) from the cable bracket on the control device assembly.
- Remove the key interlock cable from the key interlock rod (E).

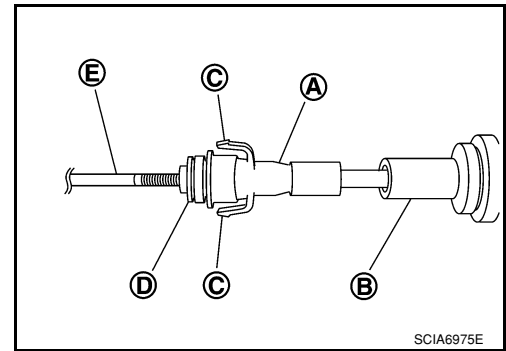

- Remove steering column cover (upper and lower) and instrument lower finisher. Refer to [IP-10](#).
- Pull out the lock plate (A) from the holder (B).
- Remove the key interlock cable (1) from the key cylinder (2).

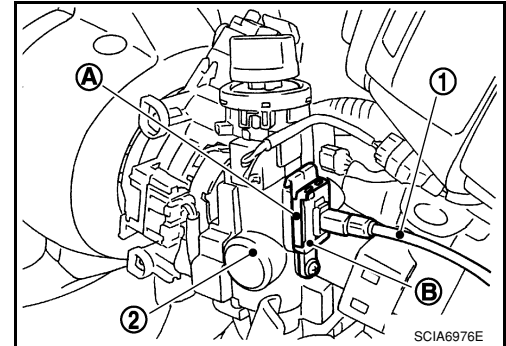

- Remove the clip (A), and then remove the key interlock cable (1).

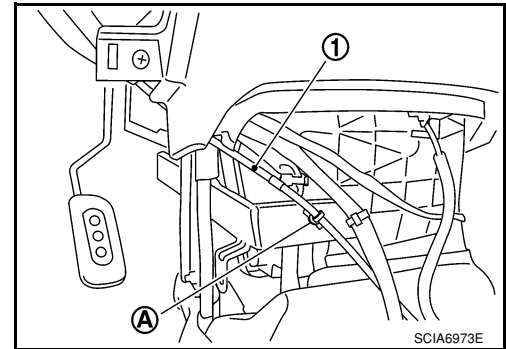

INSTALLATION

CAUTION:

- Install key interlock cable in such a way that it will not be damaged by sharp bends, twists or interference with adjacent parts.
- After installing key interlock cable to control device assembly, make sure that casing cap and bracket are firmly secured in their positions.

- Place the selector lever in the "P" position.
- Turn ignition switch to "ACC" or "ON" position.
- Set the key interlock cable (1) to the key cylinder (2).
- Install the lock plate (A) to the holder (B).
- Turn ignition switch to "LOCK" position.

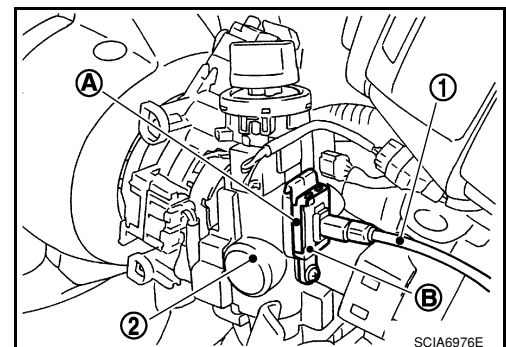

KEY INTERLOCK CABLE

< SERVICE INFORMATION >

- Temporarily install the adjust holder (A) to the key interlock rod (B).
- Install the casing cap (C) to the cable bracket (D) on the control device assembly.

CAUTION:

- Do not bend or twist key interlock cable excessively when installing.
- After installing key interlock cable to cable bracket (D) on control device assembly, make sure casing caps (C) is firmly secured in cable bracket (D) on control device assembly.
- If casing cap (C) is loose [less than 39.2 N (4.0 kg, 8.8 lb) removing force], replace key interlock cable.

- Slide the slider (A) toward the key interlock rod (D) while pressing the pull lock (B) down to securely connect the adjust holder (C) with the key interlock rod (D).

CAUTION:

- Do not press tabs when holding slider (A).
- Do not apply any side to side force to key interlock rod (D) when sliding slider (A).

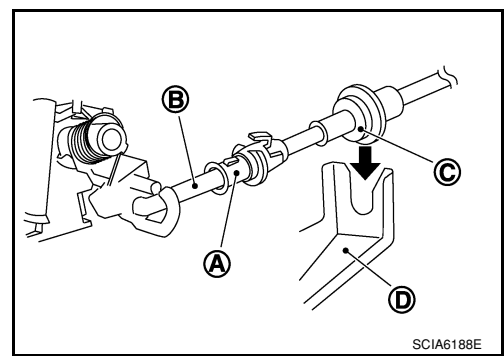

SCIA6188E

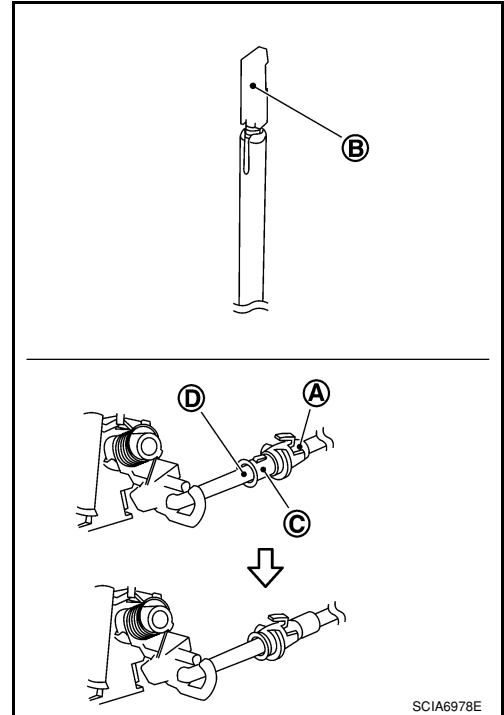

SCIA6978E

- Secure the key interlock cable (1) with the clip (A).
- Install steering column cover (upper and lower) and instrument lower finisher. Refer to [IP-10](#).
- Install the center console assembly. Refer to [IP-10](#).
- Install the selector lever knob. Refer to [CVT-170](#). "[Selector Lever Knob Removal and Installation](#)".
- Check shift lock system. Refer to [CVT-162](#). "[Description](#)".

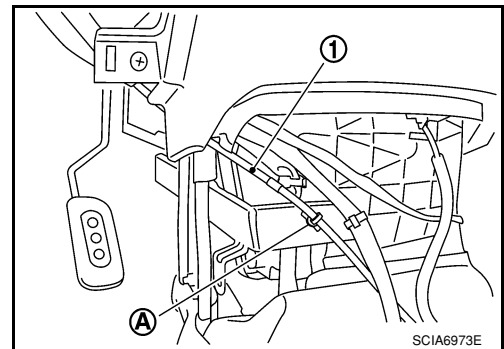

SCIA6973E

AIR BREATHER HOSE

< SERVICE INFORMATION >

AIR BREATHER HOSE

Removal and Installation

INFOID:000000001703685

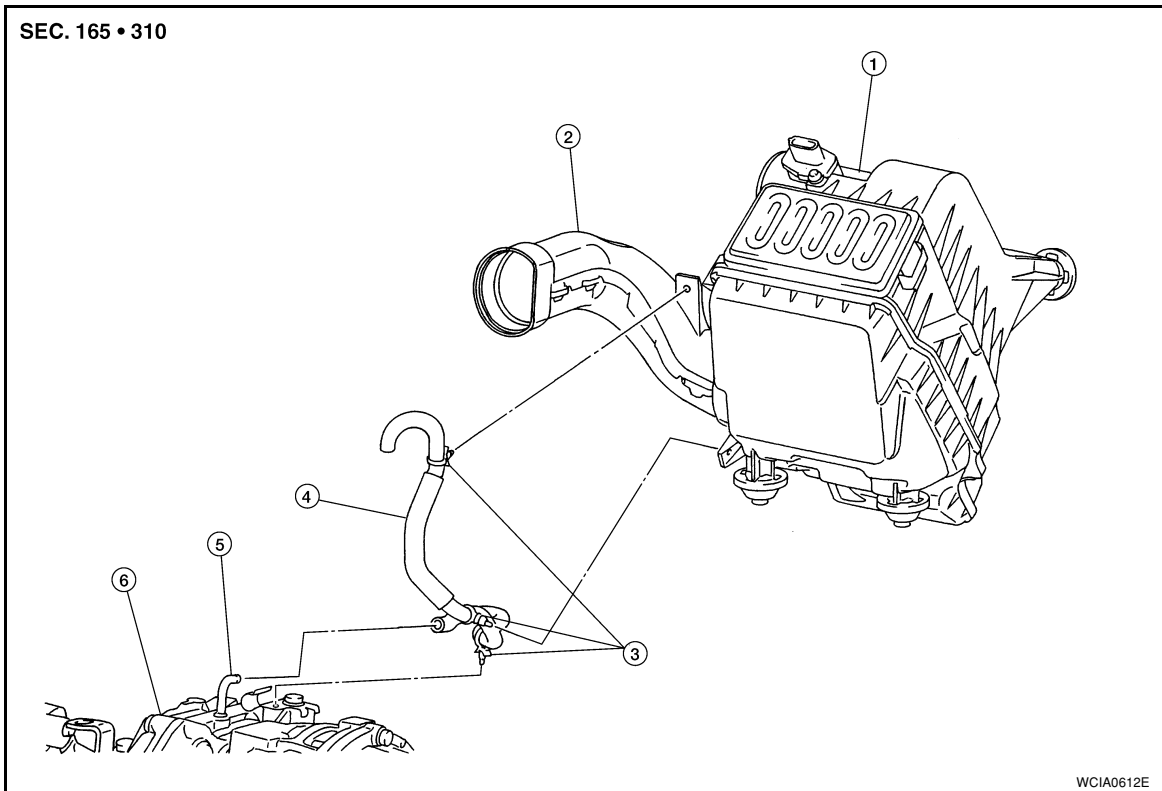

- | | | |
|----------------------|----------------------|---------|
| 1. Air cleaner case | 2. Air duct | 3. Clip |
| 4. Air breather hose | 5. Air breather tube | 6. CVT |

REMOVAL

1. Remove air duct (inlet), air duct and air cleaner case. Refer to [EM-16](#).
2. Remove air breather hose.

INSTALLATION

Installation is in the reverse order of removal.

CAUTION:

Make sure air breather hose is not collapsed or blocked due to folding or bending when installed.

NOTE:

- Install the air breather hose (1) to the air breather tube (2) so that the paint mark (A) faces upward. Also make sure the air breather hose end is pushed up to the tube bend portion.
- When installing air breather hose (1) to air duct and air cleaner case, make sure to fully insert the hose clips.

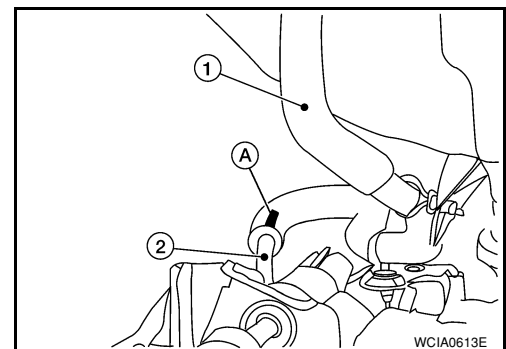

DIFFERENTIAL SIDE OIL SEAL

< SERVICE INFORMATION >

DIFFERENTIAL SIDE OIL SEAL

Removal and Installation

INFOID:000000001703686

COMPONENTS

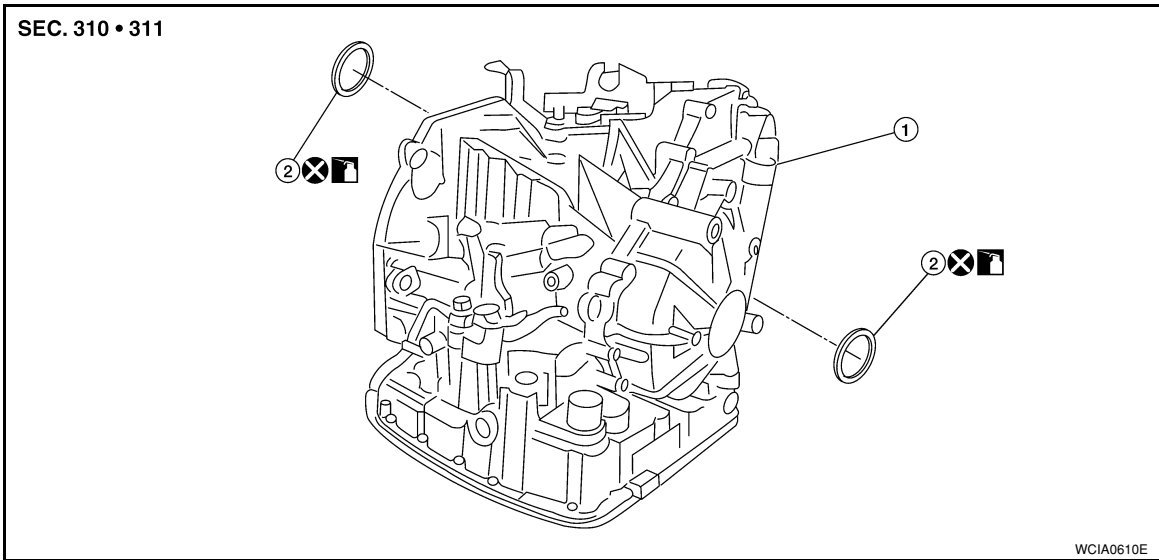

1. CVT

2. Differential side oil seal

: Apply CVT Fluid NS-2.

REMOVAL

1. Remove drive shaft assembly. Refer to [FAX-8](#).
2. Remove differential side oil seal using a suitable tool.

CAUTION:

Do not scratch transaxle case or converter housing.

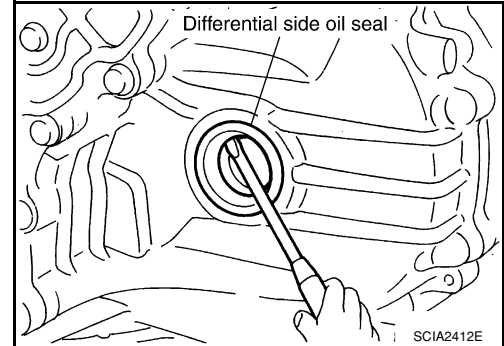

INSTALLATION

1. Drive the new differential side oil seal into the transaxle case side (B) and converter housing side (C) until it is flush using tool.

Unit: mm (in)

Tool number (Kent-Moore No.)	— (J-47244)
	ST333400001 (J-47005)
Dimensions A	0±0.5 (0±0.020)

CAUTION:

- Do not reuse differential side oil seals.
- Apply specified NISSAN CVT fluid to side oil seals.

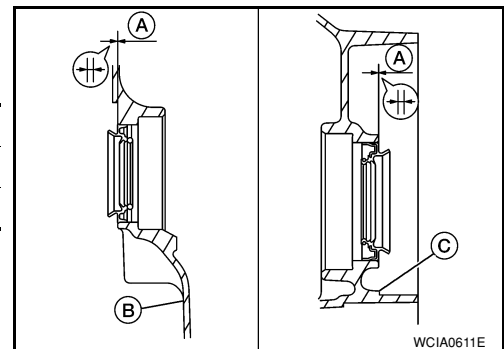

2. Install drive shaft assembly. Refer to [FAX-8](#).
3. Check CVT fluid level and leakage. Refer to [MA-19. "Checking CVT Fluid"](#).

A
B
CVT
D
E
F
G
H
I
J
K
L
M
N
O
P

TRANSAXLE ASSEMBLY

< SERVICE INFORMATION >

TRANSAXLE ASSEMBLY

Removal and Installation

INFOID:000000001703687

COMPONENTS

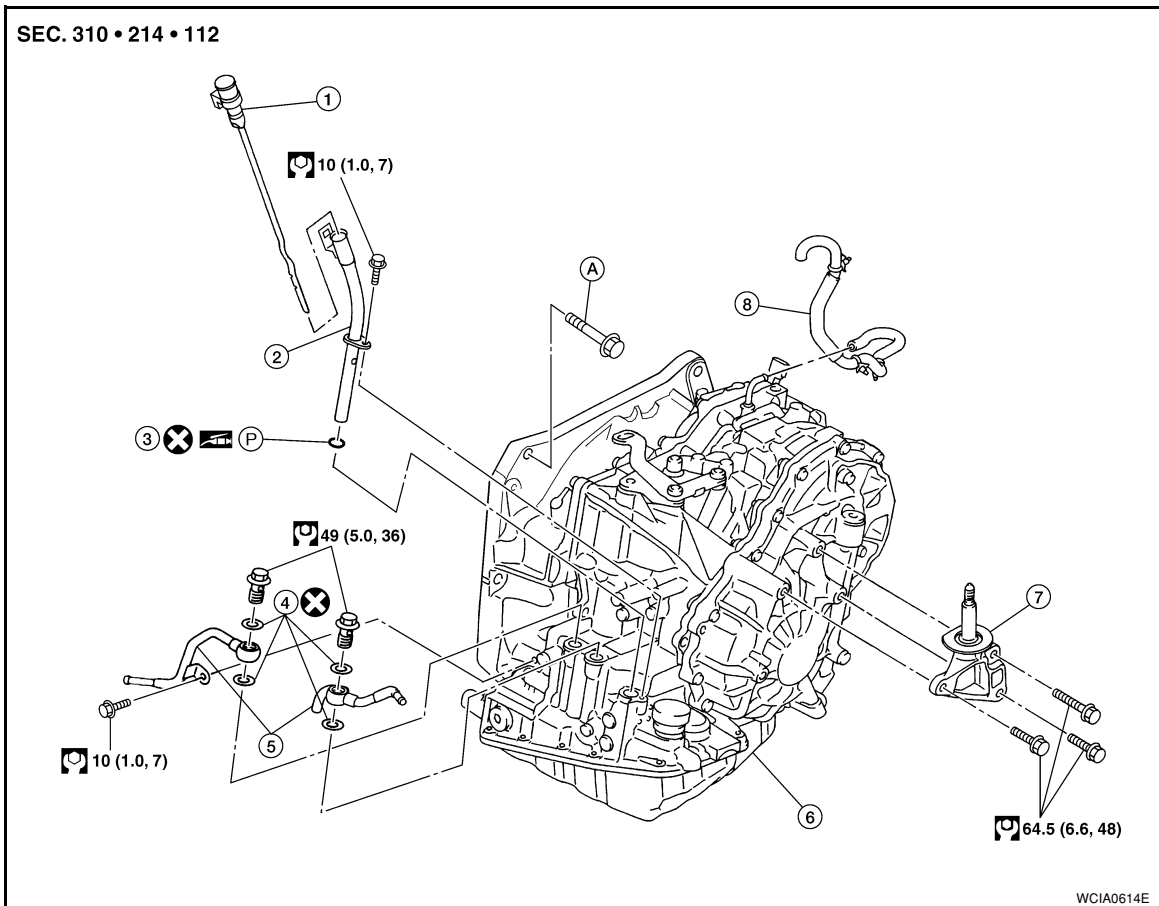

- | | | |
|---------------------------------|----------------------------|-----------------------------|
| 1. CVT fluid level gauge | 2. CVT fluid charging pipe | 3. O-ring |
| 4. Copper washer | 5. Fluid cooler tube | 6. Transaxle assembly |
| 7. Engine mounting bracket (LH) | 8. Air breather hose | A. Refer to "INSTALLATION". |

REMOVAL

1. Remove the engine and transaxle as an assembly. Refer to [EM-72. "Removal and Installation"](#).
2. Disconnect the secondary speed sensor connector (A) and CVT unit connector (B). Refer to [CVT-9. "Removal and Installation Procedure for CVT Unit Connector"](#).
3. Remove the harness from the transaxle.

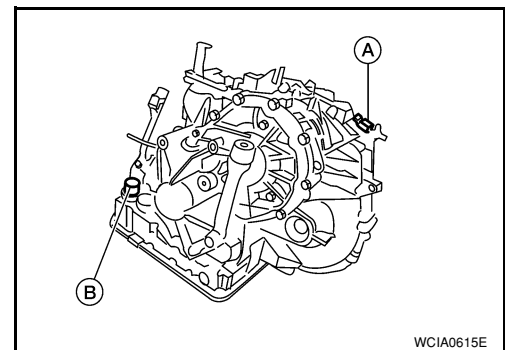

TRANSAXLE ASSEMBLY

< SERVICE INFORMATION >

4. Remove the four drive plate to torque converter nuts.

NOTE:

Rotate the crankshaft clockwise as viewed from front of engine for access to drive plate to torque converter nuts.

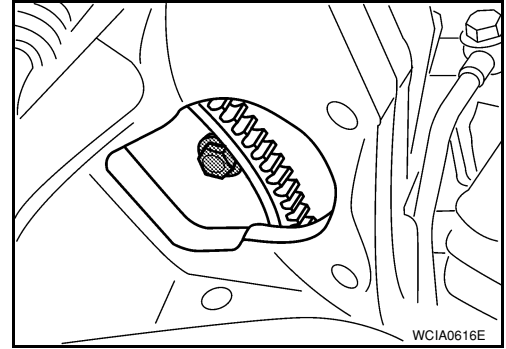

5. Put matching marks on the drive plate and torque converter alignment stud.

CAUTION:

For matching marks, use paint. Never damage the drive plate or torque converter.

6. Remove the transaxle to engine and engine to transaxle bolts.
7. Separate the transaxle from the engine.
8. If necessary, remove the following from the transaxle:
 - CVT fluid charging pipe
 - Engine mounting bracket (LH)
 - Fluid cooler tubes
 - Air breather hose
 - Any necessary brackets

INSTALLATION

Installation is in the reverse order of removal.

CAUTION:

- When replacing an engine or transmission you must make sure any dowels are installed correctly during re-assembly.
- Improper alignment caused by missing dowels may cause vibration, oil leaks or breakage of drive train components.
- Do not reuse O-rings and copper washers.
- When turning crankshaft, turn it clockwise as viewed from the front of the engine.
- When tightening the nuts for the torque converter while securing the crankshaft pulley bolt, be sure to confirm the tightening torque of the crankshaft pulley bolt. Refer to [EM-37](#).
- After converter is installed to drive plate, rotate crankshaft several turns to check that transaxle rotates freely without binding.
- When installing the torque converter to the transaxle measure distance A.

Distance A: 14.4 mm (0.57 in) or more

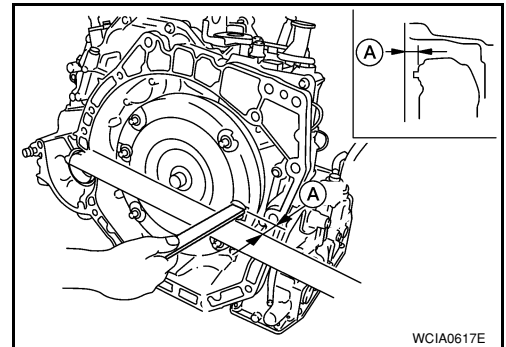

A
B
CVT
D
E
F
G
H
I
J
K
L
M
N
O
P

TRANSAXLE ASSEMBLY

< SERVICE INFORMATION >

- When installing the cooler outlet tube (1) to the transaxle assembly (2), align the cooler tube bracket (A) against the transaxle as shown.

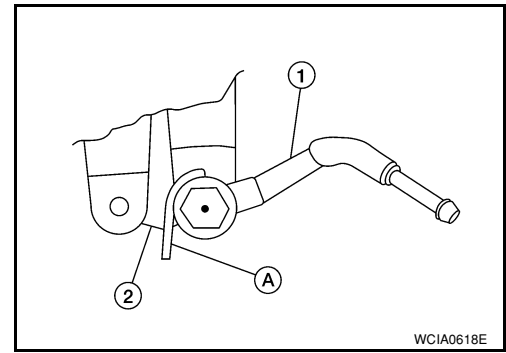

- When installing the transaxle to the engine, align the matching mark on the drive plate with the matching mark on the torque converter alignment stud.
- When securing the transaxle to the engine, attach the bolts in accordance with the following standard.

Bolt No.	1 (Transaxle to engine)	2 (Engine to transaxle)
Number of bolts	2	7
Bolt length "A" mm (in)	55 (2.17)	50 (1.97)
Tightening torque N·m (kg·m, ft·lb)	62 (6.3, 46)	

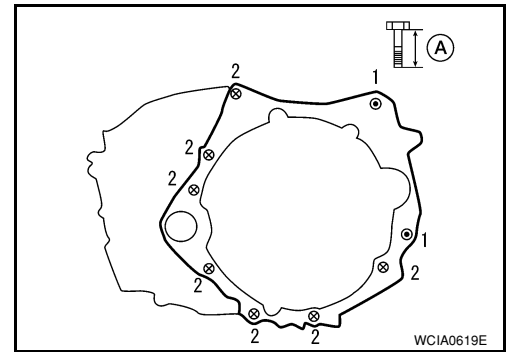

- When installing the drive plate to torque converter nuts, tighten them temporarily. Then tighten the nuts to the specified torque.

Converter nuts: : 51 N·m (5.2 kg·m, 38 ft·lb)

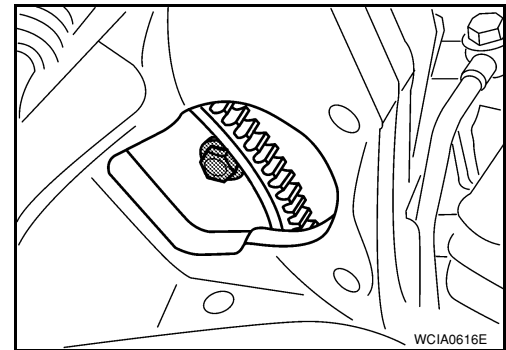

- After completing installation check for fluid level, fluid leakage, and the positions of CVT. Refer to [MA-19, "Checking CVT Fluid"](#), [CVT-171, "Adjustment of CVT Position"](#) and [CVT-171, "Checking of CVT Position"](#).
- When replacing the CVT assembly, erase EEP ROM in TCM. Refer to [CVT-8, "Service After Replacing TCM and Transaxle Assembly"](#).

SERVICE DATA AND SPECIFICATIONS (SDS)

< SERVICE INFORMATION >

SERVICE DATA AND SPECIFICATIONS (SDS)

General Specification

INFOID:000000001703688

Applied model		MR18DE engine
CVT model		RE0F08A
CVT assembly	Model code number	1XB6B
Transmission gear ratio	"D" position	Variable
	Reverse	2.689
	Final drive	5.473
Recommended fluid		NISSAN CVT Fluid NS-2*1
Fluid capacity		8.3 liter (8-3/4 US qt, 7-1/4 Imp qt)

CAUTION:

- Use only Genuine NISSAN CVT Fluid NS-2. Do not mix with other fluid.
- Using CVT fluid other than Genuine NISSAN CVT Fluid NS-2 will deteriorate in driveability and CVT durability, and may damage the CVT, which is not covered by the warranty.

*1: Refer to [MA-10. "Fluids and Lubricants"](#).

Vehicle Speed When Shifting Gears

INFOID:000000001703689

Numerical value data are reference values.

Engine type	Throttle position	Shift pattern	Engine speed (rpm)	
			At 40 km/h (25 MPH)	At 60 km/h (37 MPH)
MR18DE	8/8	"D" position Overdrive-off mode "L" position	3,600 - 4,500	4,400 - 5,300
		2/8	"D" position	1,300 - 3,100
	Overdrive-off mode		2,200 - 3,000	2,800 - 3,600
	"L" position		3,200 - 4,100	3,900 - 4,800

CAUTION:

Lock-up clutch is engaged when vehicle speed is approximately 18 km/h (11 MPH) to 90 km/h (56 MPH).

Stall Speed

INFOID:000000001703690

Stall speed	2,600 - 3,150 rpm
-------------	-------------------

Line Pressure

INFOID:000000001703691

Engine speed	Line pressure kPa (kg/cm ² , psi)
	"R", "D" and "L" positions
At idle	650 (6.63, 94.3)
At stall	4,250 (43.35, 616.3)

SERVICE DATA AND SPECIFICATIONS (SDS)

< SERVICE INFORMATION >

Solenoid Valves

INFOID:000000001703692

Name	Resistance (Approx.)	Terminal
Pressure control solenoid valve B (secondary pressure solenoid valve)	3 - 9 Ω	3
Pressure control solenoid valve A (line pressure solenoid valve)		2
Torque converter clutch solenoid valve		12
Lock-up select solenoid valve	6 - 19 Ω	13

CVT Fluid Temperature Sensor

INFOID:000000001703693

Name	Condition	CONSULT-II "DATA MONITOR" (Approx.)	Resistance (Approx.)
ATF TEMP SEN	20°C (68°F)	2.0 V	6.5 k Ω
	80°C (176°F)	1.0 V	0.9 k Ω

Primary Speed Sensor

INFOID:000000001703694

Name	Condition	Data (Approx.)
Primary speed sensor	When driving ["L" position, 20 km/h (12 MPH)].	1000 Hz

Secondary Speed Sensor

INFOID:000000001703695

Name	Condition	Data (Approx.)
Secondary speed sensor	When driving ["D" position, 20 km/h (12 MPH)].	570 Hz

Removal and Installation

INFOID:000000001703696

Distance between end of converter housing and torque converter	14.4 mm (0.57 in) or more
--	---------------------------