

# SECTION **BRC**

## BRAKE CONTROL SYSTEM

A  
B  
C  
D  
E  
G  
H  
I  
J  
K  
L  
M  
N  
O  
P

### CONTENTS

<b>ABS</b>		
<b>SERVICE INFORMATION</b> .....	Basic Inspection .....	16
<b>PRECAUTIONS</b> .....	Warning Lamp and Indicator Timing .....	17
Precaution for Supplemental Restraint System (SRS) "AIR BAG" and "SEAT BELT PRE-TENSIONER" .....	Control Unit Input/Output Signal Standard .....	17
Precaution for Brake System .....	CONSULT-III Function (ABS) .....	18
Precaution for Brake Control .....	<b>TROUBLE DIAGNOSIS FOR SELF-DIAGNOSTIC ITEMS</b> .....	<b>24</b>
Precaution for CAN System .....	Wheel Sensor System .....	24
<b>PREPARATION</b> .....	ABS Control Unit Inspection .....	25
Special Service Tool .....	Solenoid Valve System Inspection .....	25
Commercial Service Tool .....	Actuator Motor, Motor Relay, and Circuit Inspection .....	26
<b>SYSTEM DESCRIPTION</b> .....	ABS Control Unit Power and Ground Systems Inspection .....	27
System Component .....	CAN Communication System Inspection .....	28
ABS Function .....	<b>TROUBLE DIAGNOSES FOR SYMPTOMS</b> .....	<b>29</b>
EBD Function .....	ABS Works Frequently .....	29
Fail-Safe Function .....	Unexpected Pedal Action .....	29
Hydraulic Circuit Diagram .....	Long Stopping Distance .....	30
<b>CAN COMMUNICATION</b> .....	ABS Does Not Work .....	30
System Description .....	Pedal Vibration or ABS Operation Noise .....	30
<b>TROUBLE DIAGNOSIS</b> .....	<b>WHEEL SENSORS</b> .....	<b>32</b>
How to Perform Trouble Diagnosis for Quick and Accurate Repair .....	Removal and Installation .....	32
Component Parts and Harness Connector Location .....	<b>SENSOR ROTOR</b> .....	<b>34</b>
Schematic .....	Removal and Installation .....	34
Wiring Diagram - ABS - .....	<b>ACTUATOR AND ELECTRIC UNIT (ASSEMBLY)</b> .....	<b>35</b>
	Removal and Installation .....	35



## SERVICE INFORMATION

### PRECAUTIONS

#### Precaution for Supplemental Restraint System (SRS) "AIR BAG" and "SEAT BELT PRE-TENSIONER"

INFOID:000000004784402

The Supplemental Restraint System such as "AIR BAG" and "SEAT BELT PRE-TENSIONER", used along with a front seat belt, helps to reduce the risk or severity of injury to the driver and front passenger for certain types of collision. This system includes seat belt switch inputs and dual stage front air bag modules. The SRS system uses the seat belt switches to determine the front air bag deployment, and may only deploy one front air bag, depending on the severity of a collision and whether the front occupants are belted or unbelted. Information necessary to service the system safely is included in the SRS and SB section of this Service Manual.

**WARNING:**

- To avoid rendering the SRS inoperative, which could increase the risk of personal injury or death in the event of a collision which would result in air bag inflation, all maintenance must be performed by an authorized NISSAN/INFINITI dealer.
- Improper maintenance, including incorrect removal and installation of the SRS can lead to personal injury caused by unintentional activation of the system. For removal of Spiral Cable and Air Bag Module, see the SRS section.
- Do not use electrical test equipment on any circuit related to the SRS unless instructed to in this Service Manual. SRS wiring harnesses can be identified by yellow and/or orange harnesses or harness connectors.

#### PRECAUTIONS WHEN USING POWER TOOLS (AIR OR ELECTRIC) AND HAMMERS

**WARNING:**

- When working near the Airbag Diagnosis Sensor Unit or other Airbag System sensors with the Ignition ON or engine running, DO NOT use air or electric power tools or strike near the sensor(s) with a hammer. Heavy vibration could activate the sensor(s) and deploy the air bag(s), possibly causing serious injury.
- When using air or electric power tools or hammers, always switch the Ignition OFF, disconnect the battery, and wait at least 3 minutes before performing any service.

#### Precaution for Brake System

INFOID:000000004307251

**CAUTION:**

- Refer to [MA-14](#) for recommended brake fluid.
- Never reuse drained brake fluid.
- Be careful not to splash brake fluid on painted areas; it may cause paint damage. If brake fluid is splashed on painted areas, wash it away with water immediately.
- To clean or wash all parts of master cylinder and disc brake caliper, use clean brake fluid.
- Never use mineral oils such as gasoline or kerosene. They will ruin rubber parts of the hydraulic system.
- Use flare nut wrench when removing and installing brake tube.
- If a brake fluid leak is found, the part must be disassembled without fail. Then it has to be replaced with a new one if a defect exists.
- Turn the ignition switch OFF and remove the connector of the ABS actuator and electric unit (control unit) or the battery terminal before performing the work.
- Always torque brake lines when installing.
- Burnish the brake contact surfaces after refinishing or replacing rotors, after replacing pads, or if a soft pedal occurs at very low mileage. Refer to [BR-32](#), "[Brake Burnishing Procedure](#)".

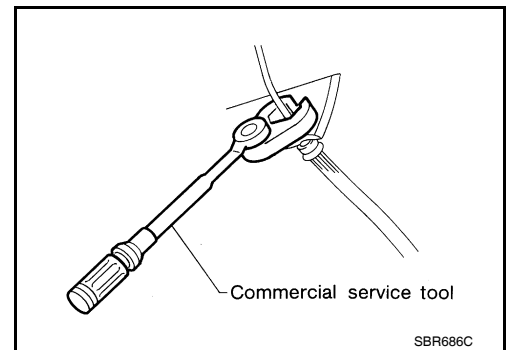

**WARNING:**

- Clean brake pads and shoes with a waste cloth, then wipe with a dust collector.

# PRECAUTIONS

< SERVICE INFORMATION >

[ABS]

## Precaution for Brake Control

INFOID:000000004307252

- During ABS operation, the brake pedal may vibrate lightly and a mechanical noise may be heard. This is normal.
- Just after starting the vehicle, the brake pedal may vibrate or motor operating noises may be heard from engine compartment. This is normal due to the self check operation.
- Stopping distance may be longer than that of vehicles without ABS when vehicle drives on rough, gravel, or snow-covered (fresh, deep snow) roads.
- When an error is indicated by ABS or another warning lamp, collect all necessary information from customer (what symptoms are present under what conditions) and check for simple causes before starting diagnosis. Besides electrical system inspection, check brake booster operation, brake fluid level, and fluid leaks.
- If incorrect tire sizes or types are installed on the vehicle or brake pads are not Genuine NISSAN parts, stopping distance or steering stability may deteriorate.
- If there is a radio, antenna or related wiring near the control module, ABS function may have a malfunction or error.
- If aftermarket parts (car stereo, CD player, etc.) have been installed, check for incidents such as harness pinches, open circuits or improper wiring.

## Precaution for CAN System

INFOID:000000004307253

- Do not apply voltage of 7.0V or higher to terminal to be measured.
- Maximum open terminal voltage of tester in use must be less than 7.0V.
- Before checking harnesses, turn ignition switch OFF and disconnect battery negative cable.
- Area to be repaired must be soldered and wrapped with tape. Make sure that fraying of twisted wire is within 110 mm (4.33 in).

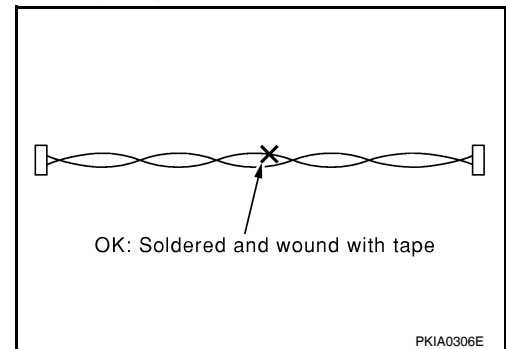

- Do not make a bypass connection to repaired area. (If the circuit is bypassed, characteristics of twisted wire will be lost.)

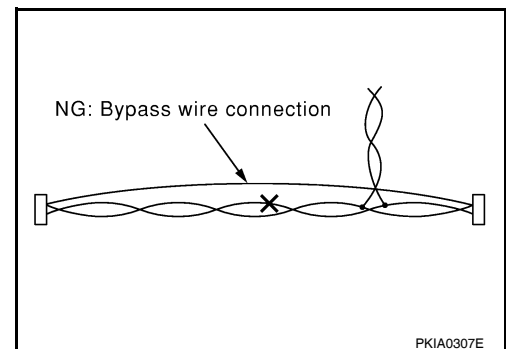

# PREPARATION

< SERVICE INFORMATION >

[ABS]

## PREPARATION

### Special Service Tool

INFOID:000000004307254

The actual shapes of Kent-Moore tools may differ from those of special service tools illustrated here.

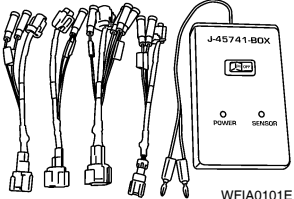
Tool number (Kent-Moore No.) Tool name	Description
<p>KV991J0080 (J-45741) ABS active wheel sensor tester</p>  <p>WFA0101E</p>	Checking operation of ABS active wheel sensors

### Commercial Service Tool

INFOID:000000004307255

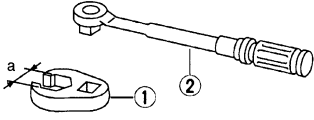
Tool name	Description
<p>1. Flare nut crowfoot 2. Torque wrench</p>  <p>S-NT360</p>	Removing and installing brake piping <b>a: 10 mm (0.39 in)/12 mm (0.47 in)</b>

## SYSTEM DESCRIPTION

### System Component

INFOID:000000004307256

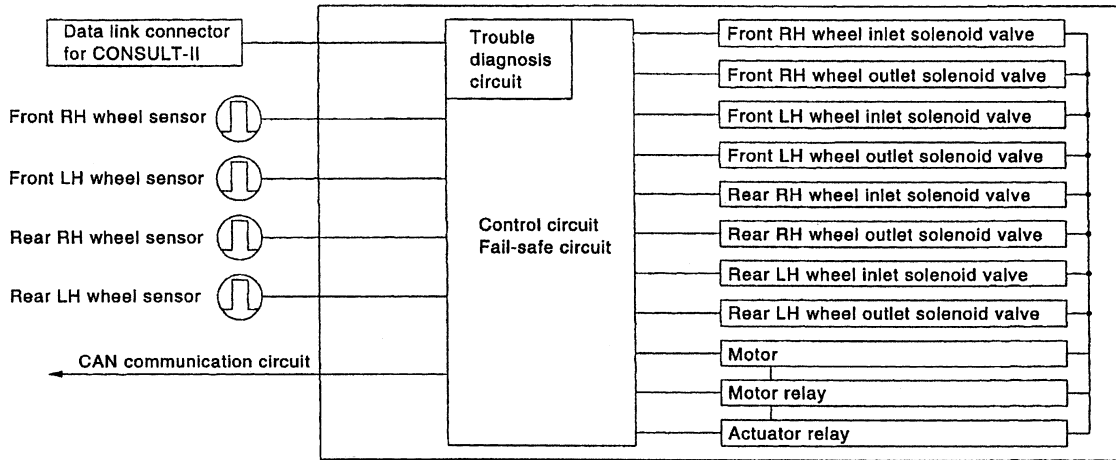

ABS actuator and control unit

WFIA0118E

### ABS Function

INFOID:000000004307257

- The Anti-Lock Brake System detects wheel revolution while braking and improves handling stability during sudden braking by electrically preventing wheel lockup. Maneuverability is also improved for avoiding obstacles during emergency braking.
- If the electrical system malfunctions, the Fail-Safe function is activated, the ABS becomes inoperative and the ABS warning lamp turns on.
- The electrical system can be diagnosed using CONSULT-III.
- During ABS operation, the brake pedal may vibrate lightly and a mechanical noise may be heard. This is normal.
- Just after starting the vehicle, the brake pedal may vibrate or motor operating noises may be heard from the engine compartment. This is normal due to the self check operation.
- Stopping distance may be longer than that of vehicles without ABS when vehicle drives on rough, gravel, or snow-covered (fresh, deep snow) roads.

### EBD Function

INFOID:000000004307258

- Electronic Brake Distribution is a function that detects subtle slippages between the front and rear wheels during braking, and it improves handling stability by electronically controlling the brake fluid pressure which results in reduced rear wheel slippage.
- If the electrical system malfunctions, the Fail-Safe function is activated, the EBD and ABS become inoperative, and the ABS warning lamp and brake warning lamp are turned on.
- The electrical system can be diagnosed using CONSULT-III.
- During EBD operation, the brake pedal may vibrate lightly and a mechanical noise may be heard. This is normal.
- Just after starting the vehicle, the brake pedal may vibrate or motor operating noises may be heard from the engine compartment. This is normal due to the self check operation.

### Fail-Safe Function

INFOID:000000004307259

**CAUTION:**

**If the Fail-Safe function is activated, perform the Self Diagnosis for ABS system.**

### ABS/EBD SYSTEM

In case of an electrical malfunction with the ABS, the ABS warning lamp will turn on. In case of an electrical malfunction with the EBD system, the brake warning lamp and the ABS warning lamp will turn on. The system will revert to one of the following conditions of the Fail-Safe function.

1. For ABS malfunction, only the EBD is operative and the condition of the vehicle is the same condition of vehicles without ABS system.

# SYSTEM DESCRIPTION

[ABS]

< SERVICE INFORMATION >

- For EBD malfunction, the EBD and ABS become inoperative, and the condition of the vehicle is the same as the condition of vehicles without ABS or EBD system.

## Hydraulic Circuit Diagram

INFOID:000000004307260

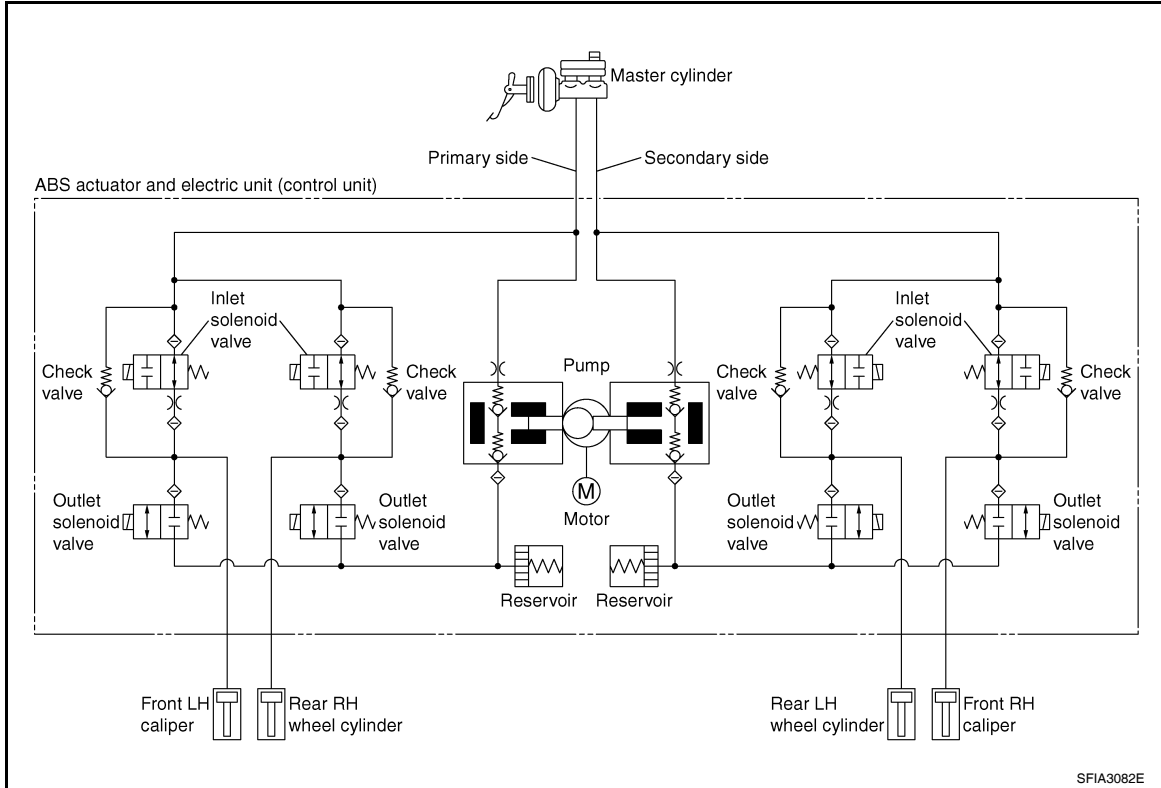

---

CAN COMMUNICATION

System Description

INFOID:000000004307261

Refer to [LAN-8. "System Description"](#).

A

B

C

D

E

**BRC**

G

H

I

J

K

L

M

N

O

P

## TROUBLE DIAGNOSIS

## How to Perform Trouble Diagnosis for Quick and Accurate Repair

INFOID:000000004307262

## INTRODUCTION

The ABS system has an electronic control unit to control major functions. The control unit accepts input signals from sensors and controls actuator operation. It is also important to check for air leaks in the booster or brake and vacuum lines, lack of brake fluid, or other malfunctions in the brake system.

It is much more difficult to diagnose a malfunction that occurs intermittently rather than continuously. Most intermittent conditions are caused by poor electrical connections or damaged wiring. In this case, careful checking of suspicious circuits may help prevent the replacement of good parts.

A visual check only may not find the cause of the malfunction, so a road test should be performed.

Before undertaking actual checks, take just a few minutes to talk with a customer who approaches with an ABS complaint. The customer is a very good source of information, especially for intermittent conditions. Through the talks with the customer, find out what symptoms are present and under what conditions they occur.

Start your diagnosis by looking for "conventional" malfunctions first. This is one of the best ways to troubleshoot brake malfunctions on an ABS equipped vehicle. Also check related Service Bulletins for information.

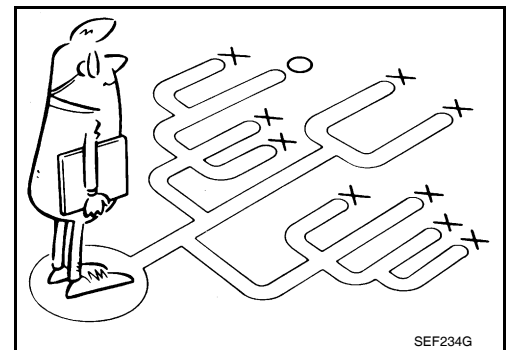
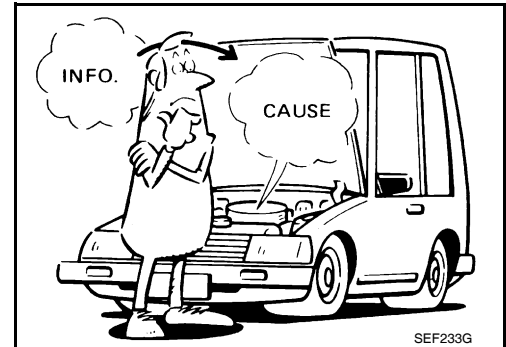



# TROUBLE DIAGNOSIS

[ABS]

< SERVICE INFORMATION >

WORK FLOW

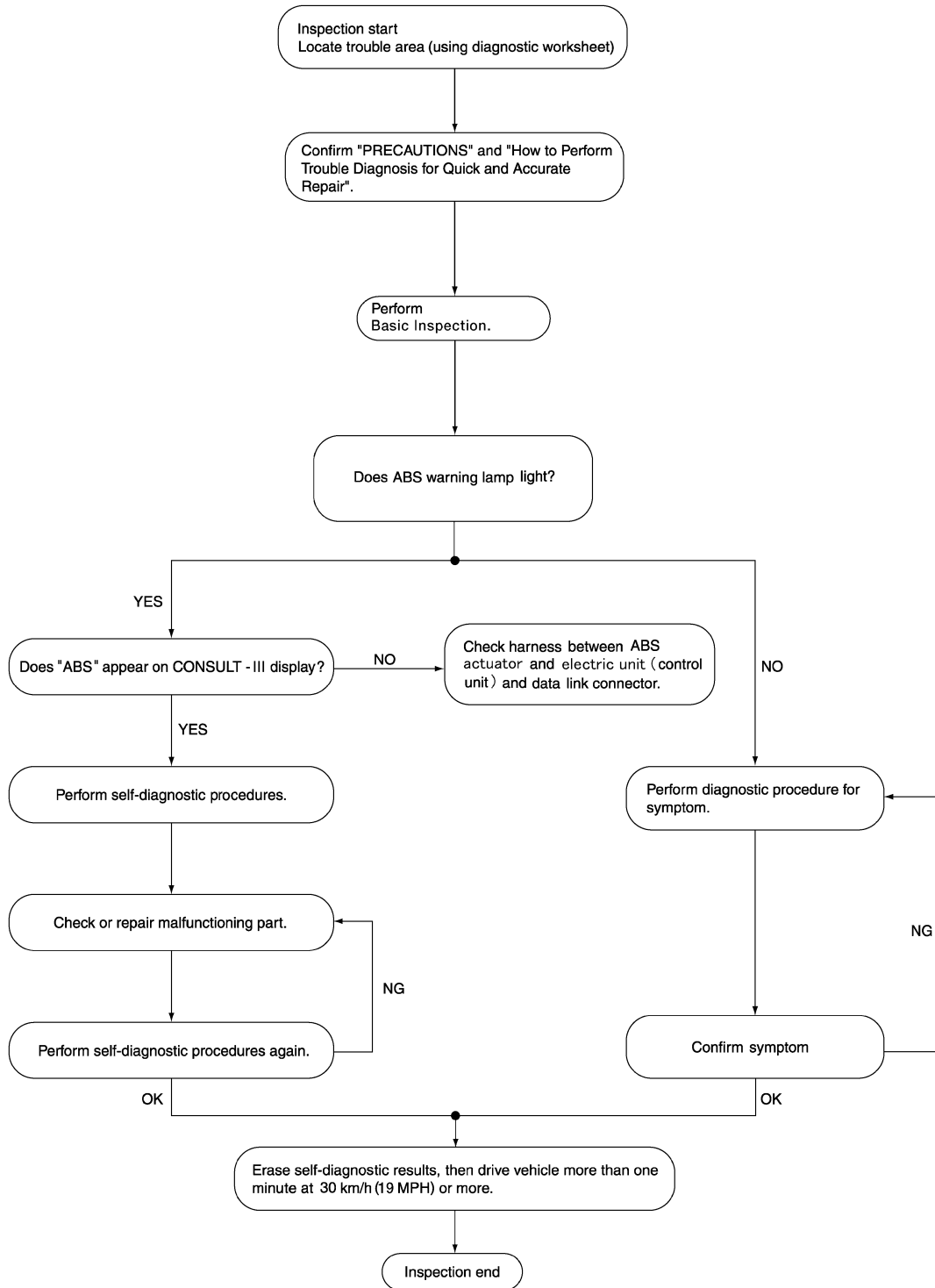

A

B

C

D

E

BRC

G

H

I

J

K

L

M

N

O

P

CLARIFY CONCERN

AWFIA0086GB

# TROUBLE DIAGNOSIS

[ABS]

< SERVICE INFORMATION >

- A customer's description of a vehicle concern may vary depending on the individual. It is important to clarify the customer's concern.
- Ask the customer about what symptoms are present under what conditions. Use this information to reproduce the symptom while driving.
- It is also important to use the diagnosis sheet to understand what type of symptoms the customer is experiencing.

**KEY POINTS**

**WHAT** ..... Vehicle model  
**WHEN** ..... Date, Frequencies  
**WHERE** ..... Road conditions  
**HOW** ..... Operating conditions,  
 Weather conditions,  
 Symptoms

SBR339B

EXAMPLE OF DIAGNOSIS SHEET

Customer name MR/MS	Model & Year	VIN	
Engine #	Trans.	Mileage	
Incident Date	Manuf. Date	In Service Date	
Symptoms	<input type="checkbox"/> Noise and vibration (from engine compartment) <input type="checkbox"/> Noise and vibration (from axle)	<input type="checkbox"/> Warning / Indicator activate	<input type="checkbox"/> Firm pedal operation <input type="checkbox"/> Large stroke pedal operation
	<input type="checkbox"/> ABS does not work (Wheels lock when braking)	<input type="checkbox"/> Lack of sense of acceleration	
Engine conditions	<input type="checkbox"/> When starting <input type="checkbox"/> After starting		
Road conditions	<input type="checkbox"/> Low friction road ( <input type="checkbox"/> Snow <input type="checkbox"/> Gravel <input type="checkbox"/> Other ) <input type="checkbox"/> Bumps / potholes		
Driving conditions	<input type="checkbox"/> Full-acceleration <input type="checkbox"/> High speed cornering <input type="checkbox"/> Vehicle speed: Greater than 10 km/h (6 MPH) <input type="checkbox"/> Vehicle speed: 10 km/h (6 MPH) or less <input type="checkbox"/> Vehicle is stopped		
Applying brake conditions	<input type="checkbox"/> Suddenly <input type="checkbox"/> Gradually		
Other conditions	<input type="checkbox"/> Operation of electrical equipment <input type="checkbox"/> Shift change <input type="checkbox"/> Other descriptions		

SFIA3264E

# TROUBLE DIAGNOSIS

< SERVICE INFORMATION >

[ABS]

## Component Parts and Harness Connector Location

INFOID:000000004307263

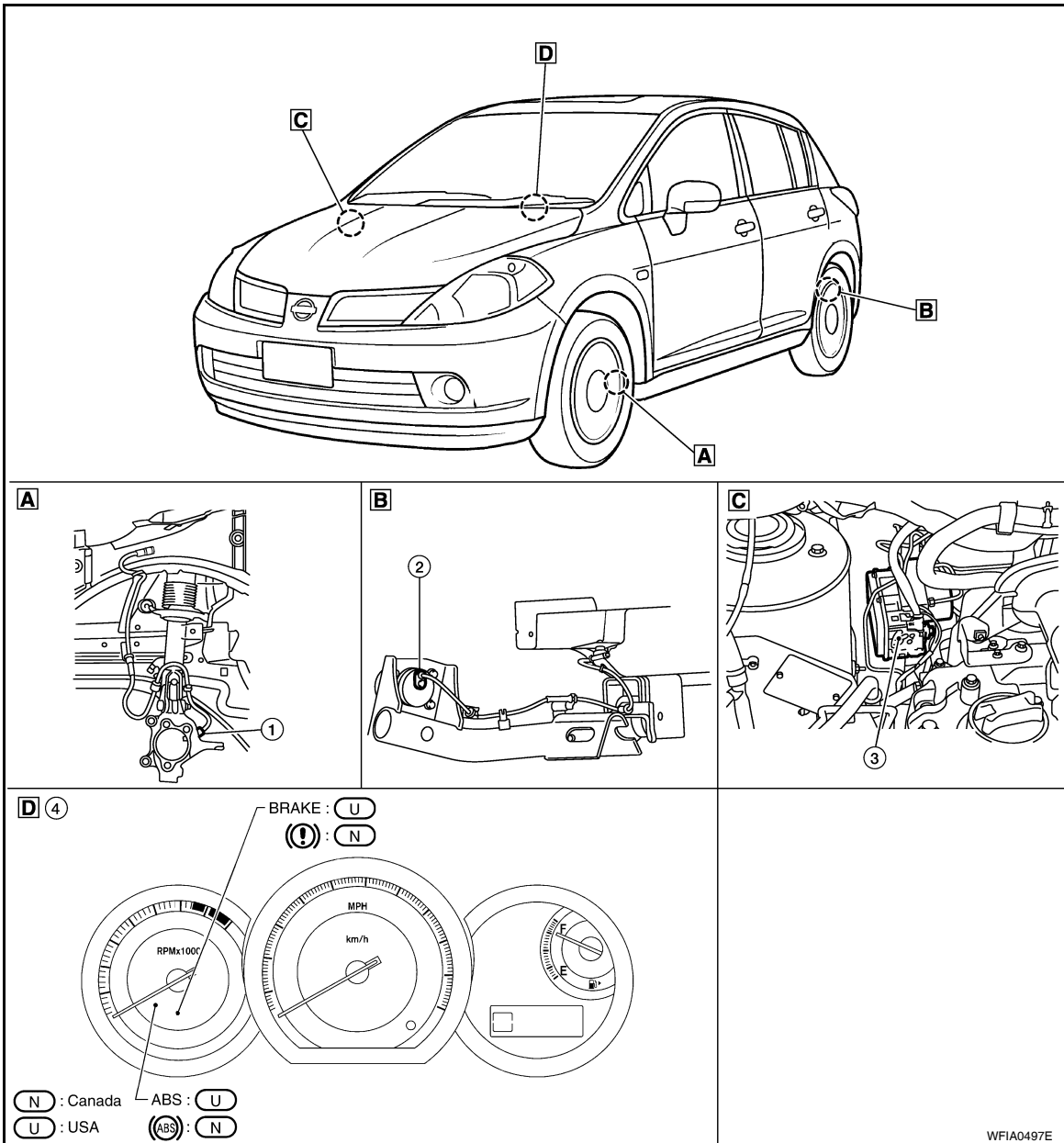

- |  |   |   |
|--|---|---|
| <p>1. Front wheel sensor<br/>LH E51<br/>RH E52</p> | <p>2. Rear wheel sensor<br/>LH B123<br/>RH B124</p> | <p>3. ABS actuator and electric unit (control unit) E33</p> |
| <p>4. Combination meter M24</p>                    |   |   |

A  
B  
C  
D  
E  
BRC  
G  
H  
I  
J  
K  
L  
M  
N  
O  
P

# TROUBLE DIAGNOSIS

[ABS]

< SERVICE INFORMATION >

## Schematic

INFOID:000000004307264

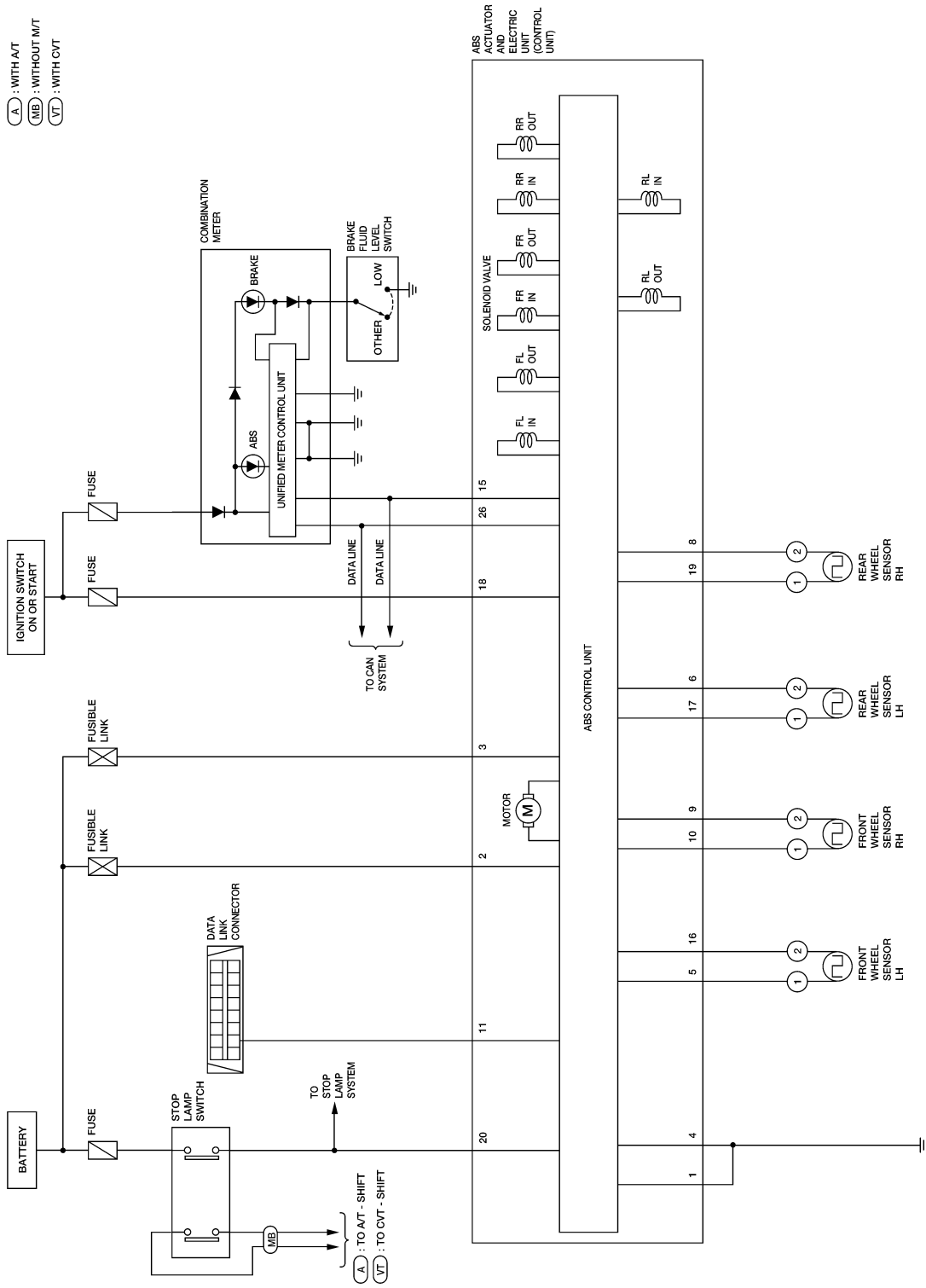

WFWA0418E

# TROUBLE DIAGNOSIS

[ABS]

< SERVICE INFORMATION >

## Wiring Diagram - ABS -

INFOID:000000004307265

### BRC-ABS-01

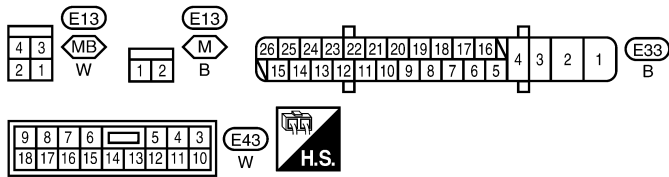
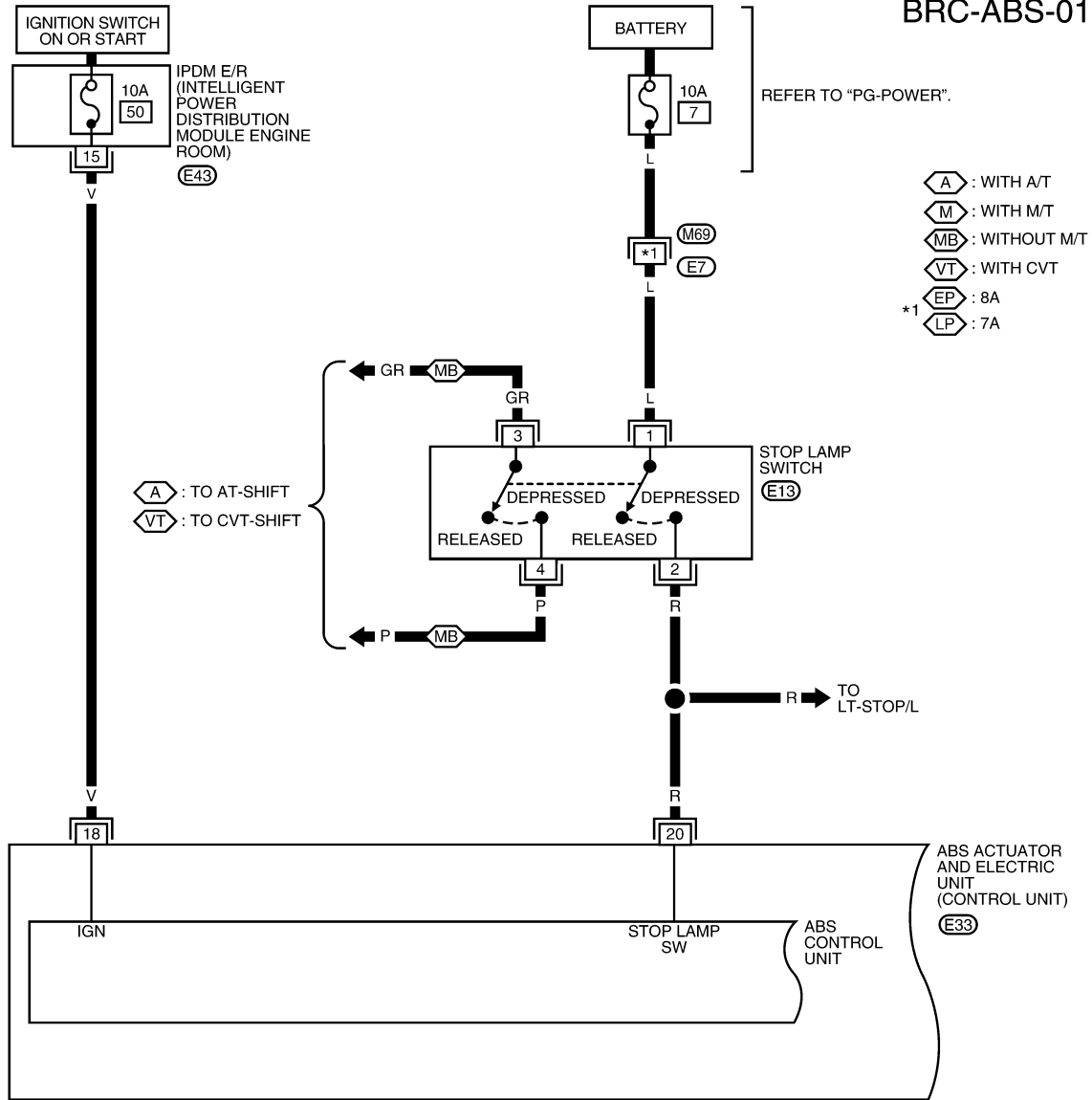

REFER TO THE FOLLOWING.  
(M69) - SUPER MULTIPLE JUNCTION (SMJ)

AAFWA0013GE

# TROUBLE DIAGNOSIS

< SERVICE INFORMATION >

[ABS]

BRC-ABS-02

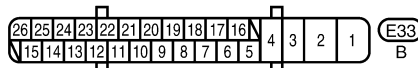
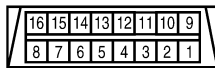
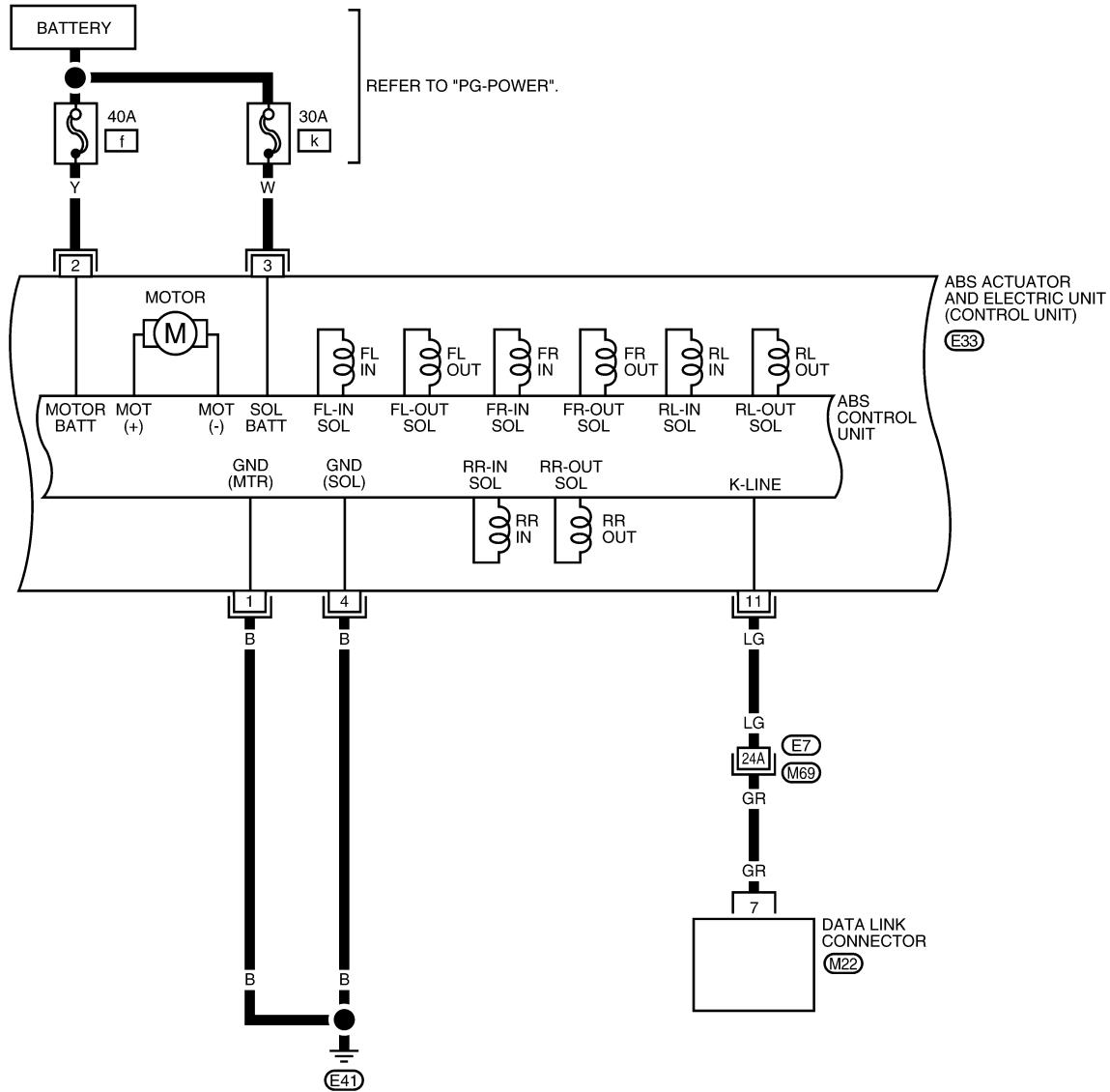

REFER TO THE FOLLOWING.  
 (M69) - SUPER MULTIPLE JUNCTION (SMJ)

WFWA0420E

# TROUBLE DIAGNOSIS

< SERVICE INFORMATION >

[ABS]

BRC-ABS-03

— : DATA LINE

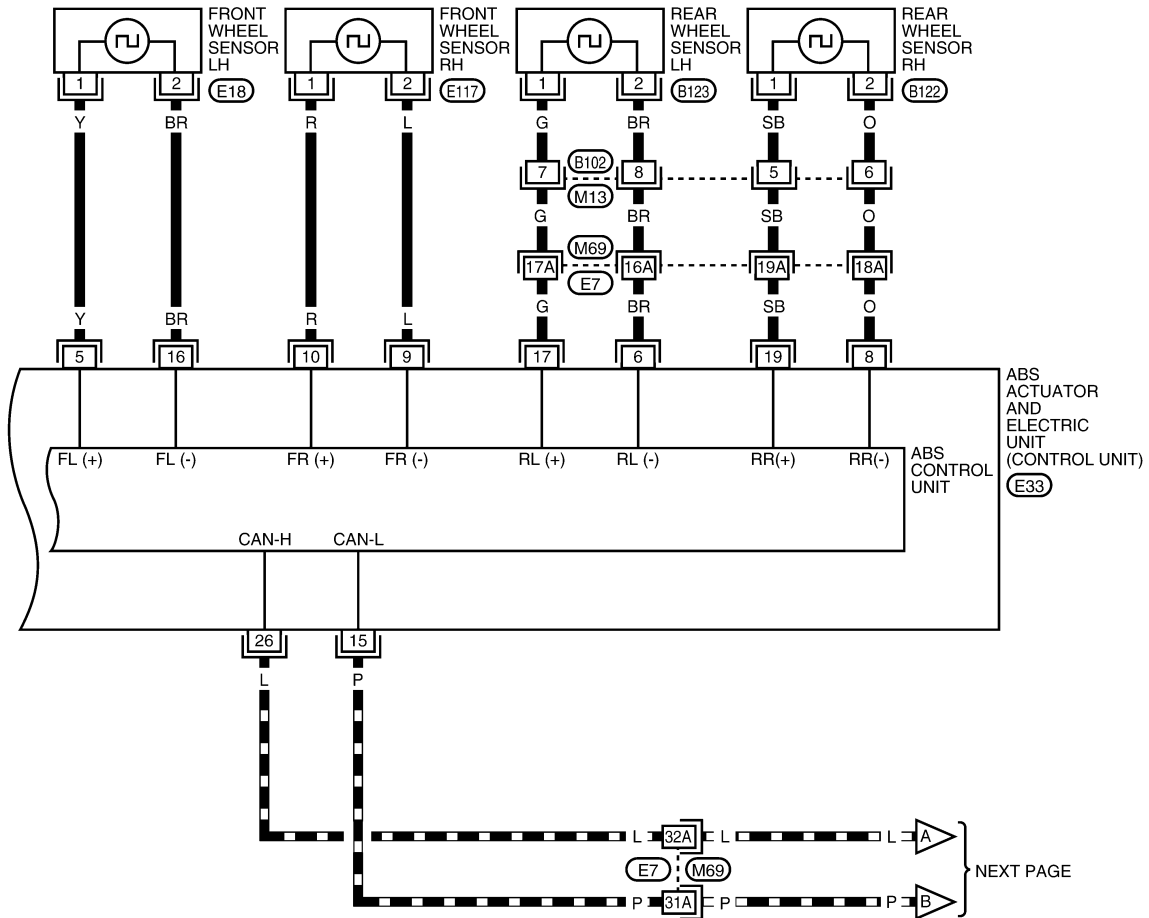

A  
B  
C  
D  
E  
BRC  
G  
H  
I  
J  
K  
L  
M  
N  
O  
P

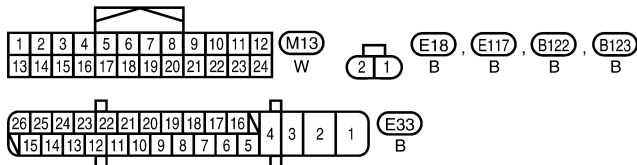

REFER TO THE FOLLOWING.  
M69 - SUPER MULTIPLE JUNCTION (SMJ)

WFWA0421E

# TROUBLE DIAGNOSIS

## BRC-ABS-04

— : DATA LINE

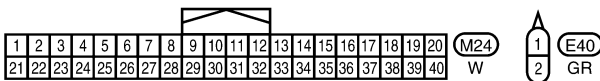
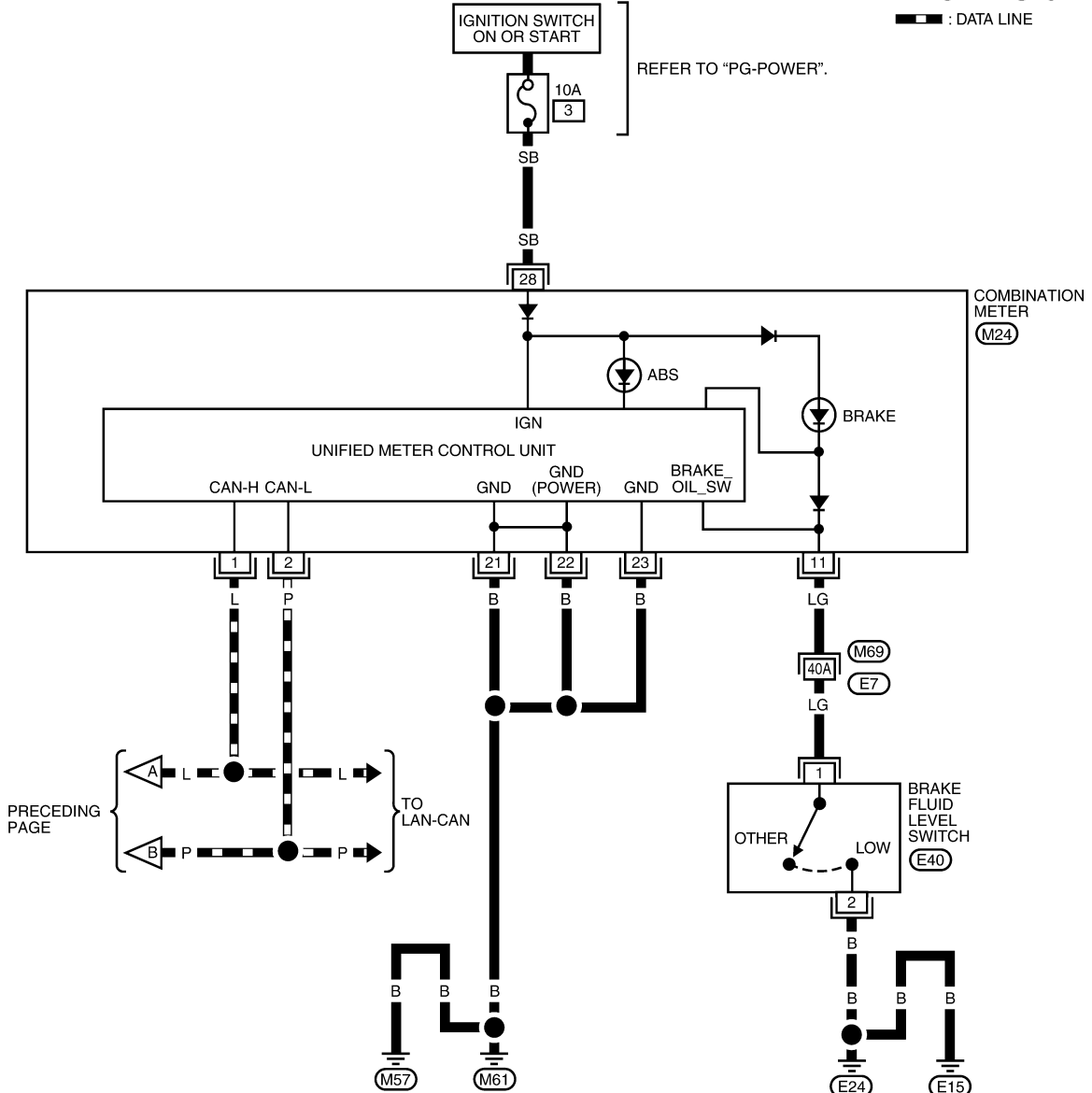

REFER TO THE FOLLOWING.  
**(M69)** - SUPER MULTIPLE JUNCTION (SMJ)

WFWA0422E

## Basic Inspection

INFOID:000000004307266

### BRAKE FLUID LEVEL, FLUID LEAK, AND BRAKE PAD INSPECTION

1. Check fluid level in the brake fluid reservoir. If fluid level is low, add fluid.
2. Check the brake piping and around the ABS actuator and electric unit (control unit) for leaks. If there is leaking or seeping fluid, check the following items.



# TROUBLE DIAGNOSIS

[ABS]

## < SERVICE INFORMATION >

- If ABS actuator and electric unit (control unit) connection is loose, tighten the piping to the specified torque and recheck for leaks.
- If there is damage to the connection flare nut or ABS actuator and electric unit (control unit) threads, replace the damaged part and recheck for leaks.
- When there is fluid leaking or seeping from a fluid connection, use a clean cloth to wipe off the fluid and recheck for leaks. If fluid is still seeping out, replace the damaged part. If the fluid is leaking at the ABS actuator and electric unit (control unit), replace the ABS actuator and electric unit (control unit) assembly.

### **CAUTION:**

**The ABS actuator and electric unit (control unit) cannot be disassembled and must be replaced as an assembly.**

3. Check the brake pads for excessive wear.

## POWER SYSTEM TERMINAL LOOSENESS AND BATTERY INSPECTION

Make sure the battery positive cable, negative cable and ground connection are not loose. In addition, make sure the battery is sufficiently charged.

## ABS WARNING LAMP INSPECTION

1. Make sure ABS warning lamp turns on for approximately 2 seconds when the ignition switch is turned ON. If it does not, check CAN communications. If there are no errors with the CAN communication system, replace the combination meter. Refer to [IP-12, "Removal and Installation"](#).
2. Make sure the lamp turns off approximately 2 seconds after the ignition switch is turned ON. If the lamp does not turn off, conduct self-diagnosis of ABS actuator and electric unit (control unit). If no malfunctions are detected in self-diagnosis, replace combination meter. Refer to [IP-12, "Removal and Installation"](#).
3. After conducting the self-diagnosis, be sure to erase the error memory. Refer to [BRC-18, "CONSULT-III Function \(ABS\)"](#).

## Warning Lamp and Indicator Timing

INFOID:000000004307267

Condition	ABS warning lamp	BRAKE warning lamp [Note 1]	Remarks
When the ignition switch is OFF	–	–	–
After the ignition switch is turned ON for approx. 1 second	×	×	–
After the ignition switch is turned ON for approx. 2 seconds	–	–	Lamp goes off approx. 2 seconds after the engine is started.
ABS malfunction	×	–	–
EBD malfunction	×	×	–

Note 1: Brake warning lamp will turn on when the parking brake is applied or when the brake fluid level is low.

x: ON

–: OFF

## Control Unit Input/Output Signal Standard

INFOID:000000004307268

## REFERENCE VALUE FROM CONSULT-III

### **CAUTION:**

**The display shows the control unit calculation data, so a normal value might be displayed even in the event the output circuit (harness) is open or short circuited.**

# TROUBLE DIAGNOSIS

< SERVICE INFORMATION >

[ABS]

Monitor item	Display content	Data monitor		Note: Error inspection checklist
		Condition	Reference value in normal operation	
FR RH SENSOR FR LH SENSOR RR RH SENSOR RR LH SENSOR	Wheel speed	Vehicle stopped	0 [km/h (MPH)]	<a href="#">BRC-24, "Wheel Sensor System"</a>
		Vehicle running (Note 1)	Almost in accordance with speedometer display (within ±10%)	
BATTERY VOLT	Battery voltage supplied to ABS actuator and electric unit (control unit)	Ignition switch ON	10 to 16V	<a href="#">BRC-27, "ABS Control Unit Power and Ground Systems Inspection"</a>
STOP LAMP SW	Stop lamp switch operation	Brake pedal depressed	ON	—
		Brake pedal not depressed	OFF	
ABS WARN LAMP	ABS warning lamp ON condition (Note 2)	ABS warning lamp ON	ON	<a href="#">BRC-16, "Basic Inspection"</a>
		ABS warning lamp OFF	OFF	
MOTOR RELAY	Operation status of motor and motor relay	Ignition switch ON or running (ABS not activated)	OFF	<a href="#">BRC-26, "Actuator Motor, Motor Relay, and Circuit Inspection"</a>
		Ignition switch ON or engine running (ABS activated)	ON	
ACTUATOR RLY	Actuator relay operation status	Vehicle stopped (Ignition switch ON)	OFF	<a href="#">BRC-26, "Actuator Motor, Motor Relay, and Circuit Inspection"</a>
		Vehicle stopped (Engine running)	ON	
FR LH IN SOL FR LH OUT SOL FR RH IN SOL FR RH OUT SOL RR RH IN SOL RR RH OUT SOL RR LH IN SOL RR LH OUT SOL	Solenoid valve operation	Actuator (solenoid) is active ("ACTIVE TEST" with CONSULT-III) or actuator relay is inactive (in fail-safe mode).	ON	<a href="#">BRC-25, "Solenoid Valve System Inspection"</a>
		When actuator (solenoid) is not active and actuator relay is active (ignition switch ON).	OFF	
ABS SIGNAL EBD SIGNAL	Signal status	ABS active EBD active	ON	ABS system EBD system
		ABS not active EBD not active	OFF	
ABS FAIL SIG EBD FAIL SIG	Fail signal status	ABS fail EBD fail	ON	ABS system EBD system
		ABS normal EBD normal	OFF	

Note 1: Confirm tire pressure is normal.

Note 2: ON/OFF timing of ABS warning lamp

ON: For approximately 2 seconds after ignition switch is turned ON, or when a malfunction is detected.

OFF: Approximately 2 seconds after ignition switch is turned ON (when system is in normal operation).

## CONSULT-III Function (ABS)

INFOID:000000004307269

CONSULT-III can display each diagnostic item using the diagnostic test modes shown following.

ABS diagnostic mode	Description
SELF-DIAG RESULTS	Displays ABS actuator and electric unit (control unit) self-diagnosis results.
DATA MONITOR	Displays ABS actuator and electric unit (control unit) input/output data in real time.
CAN DIAG SUPPORT MNTR	The result of transmit/receive diagnosis of CAN communication can be read.
ACTIVE TEST	Operation of electrical loads can be checked by sending drive signal to them.

# TROUBLE DIAGNOSIS

[ABS]

## < SERVICE INFORMATION >

ABS diagnostic mode	Description
FUNCTION TEST	Conducted by CONSULT-III instead of a technician to determine whether each system is "OK" or "NG".
ECU PART NUMBER	ABS actuator and electric unit (control unit) part number can be read.

## SELF-DIAGNOSIS

### Description

If an error is detected in the system, the ABS warning lamp will turn on. In this case, perform self-diagnosis as follows:

### Operation Procedure

1. Turn ignition switch OFF.
2. Connect CONSULT-III to the data link connector.
3. Turn ignition switch ON.
4. Start engine and drive at approximately 30 km/h (19 MPH) or more for approximately 1 minute.
5. After stopping the vehicle, with the engine running, touch "ABS", "SELF-DIAG RESULTS" in order on the CONSULT-III screen.
6. The self-diagnostic results are displayed. (If necessary, the self-diagnostic results can be printed out by touching "PRINT".)
  - When "NO DTC IS DETECTED" is displayed, check the ABS warning lamp.
7. Conduct the appropriate inspection from the display item list, and repair or replace the malfunctioning component.
8. Start engine and drive at approximately 30 km/h (19 MPH) or more for approximately 1 minute.

**CAUTION:**

  - **When a wheel sensor "short-circuit" is detected, if the vehicle is not driven at 30 km/h (19 MPH) for at least 1 minute, the ABS warning lamp will not turn off even if the malfunction is repaired.**
9. Turn ignition switch OFF to prepare for erasing the memory.
10. Start the engine and touch "ABS", "SELF-DIAG RESULTS", "ERASE" in order on the CONSULT-III screen to erase the error memory.

If "ABS" is not indicated, go to [GI-36, "CONSULT-III Data Link Connector \(DLC\) Circuit"](#).

**CAUTION:**

**If the error memory is not erased, re-conduct the operation from step 5.**
11. For the final inspection, drive at approximately 30 km/h (19 MPH) or more for approximately 1 minute and confirm that the ABS warning lamp is off.

### Display Item List

# TROUBLE DIAGNOSIS

< SERVICE INFORMATION >

[ABS]

Self-diagnostic item	Malfunction detecting condition	Check system	
RR RH SENSOR-1 [C1101]	Circuit of rear RH wheel sensor is open.		
RR LH SENSOR-1 [C1102]	Circuit of rear LH wheel sensor is open.		
FR RH SENSOR-1 [C1103]	Circuit of front RH wheel sensor is open.		
FR LH SENSOR-1 [C1104]	Circuit of front LH wheel sensor is open.		
RR RH SENSOR-2 [C1105]	When the circuit in the rear RH wheel sensor is short-circuited or when the sensor power voltage is outside the standard. When the distance between the wheel sensor and sensor rotor is too large and the sensor pulse cannot be recognized by the control unit.		
RR LH SENSOR-2 [C1106]	When the circuit in the rear LH wheel sensor is short-circuited or when the sensor power voltage is outside the standard. When the distance between the wheel sensor and sensor rotor is too large and the sensor pulse cannot be recognized by the control unit.		<a href="#">BRC-24, "Wheel Sensor System"</a> (Note 1)
FR RH SENSOR-2 [C1107]	When the circuit in the front RH wheel sensor is short-circuited or when the sensor power voltage is outside the standard. When the distance between the wheel sensor and sensor rotor is too large and the sensor pulse cannot be recognized by the control unit.		
FR LH SENSOR-2 [C1108]	When the circuit in the front LH wheel sensor is short-circuited or when the sensor power voltage is outside the standard. When the distance between the wheel sensor and sensor rotor is too large and the sensor pulse cannot be recognized by the control unit.		
ABS SENSOR [ABNORMAL SIGNAL] [C1115]	Wheel sensor input is abnormal.		
BATTERY VOLTAGE [ABNORMAL] [C1109]	ABS actuator and electric unit (control unit) power voltage is too low.		<a href="#">BRC-27, "ABS Control Unit Power and Ground Systems Inspection"</a>
CONTROLLER FAILURE [C1110]	Internal malfunction of ABS actuator and electric unit (control unit)	<a href="#">BRC-25, "ABS Control Unit Inspection"</a>	
PUMP MOTOR [C1111]	During actuator motor operation with ON, when actuator motor turns OFF or when control line for actuator motor relay is open.	<a href="#">BRC-26, "Actuator Motor, Motor Relay, and Circuit Inspection"</a>	
	During actuator motor operation with OFF, when actuator motor turns ON or when control line for relay is shorted to ground.		
FR LH IN ABS SOL [C1120]	Circuit of front LH IN ABS solenoid is open or shorted, or control line is open or shorted to power supply or ground.	<a href="#">BRC-25, "Solenoid Valve System Inspection"</a>	
FR LH OUT ABS SOL [C1121]	Circuit of front LH OUT ABS solenoid is open or shorted, or control line is open or shorted to power supply or ground.		
FR RH IN ABS SOL [C1122]	Circuit of front RH IN ABS solenoid is open or shorted, or control line is open or shorted to power supply or ground.		
FR RH OUT ABS SOL [C1123]	Circuit of front RH OUT ABS solenoid is open or shorted, or control line is open or shorted to power supply or ground.		
RR LH IN ABS SOL [C1124]	Circuit of rear LH IN ABS solenoid is open or shorted, or control line is open or shorted to power supply or ground.		
RR LH OUT ABS SOL [C1125]	Circuit of rear LH OUT ABS solenoid is open or shorted, or control line is open or shorted to power supply or ground.		
RR RH IN ABS SOL [C1126]	Circuit of rear RH IN ABS solenoid is open or shorted, or control line is open or shorted to power supply or ground.		
RR RH OUT ABS SOL [C1127]	Circuit of rear RH OUT ABS solenoid is open or shorted, or control line is open or shorted to power supply or ground.		

# TROUBLE DIAGNOSIS

[ABS]

## < SERVICE INFORMATION >

Self-diagnostic item	Malfunction detecting condition	Check system
MAIN RELAY [C1114]	ABS actuator relay or circuit malfunction.	<a href="#">BRC-26. "Actuator Motor, Motor Relay, and Circuit Inspection"</a>
CAN COMM CIRCUIT [U1000]	<ul style="list-style-type: none"> <li>• CAN communication line is open or shorted.</li> <li>• ABS actuator and electric unit (control unit) internal malfunction</li> <li>• Battery voltage for ECM is suddenly interrupted for approximately 0.5 second or more.</li> </ul>	<a href="#">BRC-28. "CAN Communication System Inspection"</a> (Note 2)

Note 1: If wheel sensor 2 for each wheel is indicated, check ABS actuator and electric unit (control unit) power supply voltage in addition to wheel sensor circuit check.

Note 2: If multiple malfunctions are detected including CAN communication line [U1000], perform diagnosis for CAN communication line first.

## DATA MONITOR

### Operation Procedure

1. After turning OFF the ignition switch, connect CONSULT-III to the data link connector.
2. Touch "ABS", "DATA MONITOR" in order on the CONSULT-III screen.  
If "ABS" is not indicated, go to [GI-36. "CONSULT-III Data Link Connector \(DLC\) Circuit"](#).
3. Return to the SELECT MONITOR ITEM screen, and touch "ECU INPUT SIGNALS", "MAIN SIGNALS" or "SELECTION FROM MENU". Refer to the following information.
4. When "START" is touched, the data monitor screen is displayed.

### Display Item List

Item (Unit)	Data monitor item selection			Remarks
	ECU INPUT SIGNALS	MAIN SIGNALS	SELECTION FROM MENU	
FR RH SENSOR (km/h, MPH)	×	×	×	Wheel speed calculated by front RH wheel sensor signal is displayed.
FR LH SENSOR (km/h, MPH)	×	×	×	Wheel speed calculated by front LH wheel sensor signal is displayed.
RR RH SENSOR (km/h, MPH)	×	×	×	Wheel speed calculated by rear RH wheel sensor signal is displayed.
RR LH SENSOR (km/h, MPH)	×	×	×	Wheel speed calculated by rear LH wheel sensor signal is displayed.
BATTERY VOLT (V)	×	×	×	Voltage supplied to ABS actuator and electric unit (control unit) is displayed.
STOP LAMP SW (ON/OFF)	×	×	×	Stop lamp switch (ON/OFF) status is displayed.
ABS WARN LAMP (ON/OFF)	-	×	×	ABS warning lamp (ON/OFF) status is displayed.
FR LH IN SOL (ON/OFF)	-	×	×	Front LH IN ABS solenoid (ON/OFF) status is displayed.
FR LH OUT SOL (ON/OFF)	-	×	×	Front LH OUT ABS solenoid (ON/OFF) status is displayed.
FR RH IN SOL (ON/OFF)	-	×	×	Front RH IN ABS solenoid (ON/OFF) status is displayed.
FR RH OUT SOL (ON/OFF)	-	×	×	Front RH OUT ABS solenoid (ON/OFF) status is displayed.
RR LH IN SOL (ON/OFF)	-	×	×	Rear LH IN ABS solenoid (ON/OFF) status is displayed.
RR LH OUT SOL (ON/OFF)	-	×	×	Rear LH OUT ABS solenoid (ON/OFF) status is displayed.

# TROUBLE DIAGNOSIS

< SERVICE INFORMATION >

[ABS]

Item (Unit)	Data monitor item selection			Remarks
	ECU INPUT SIGNALS	MAIN SIGNALS	SELECTION FROM MENU	
RR RH IN SOL (ON/OFF)	-	×	×	Rear RH IN ABS solenoid (ON/OFF) status is displayed.
RR RH OUT SOL (ON/OFF)	-	×	×	Rear RH OUT ABS solenoid (ON/OFF) status is displayed.
MOTOR RELAY (ON/OFF)	-	×	×	ABS motor relay signal (ON/OFF) status is displayed.
ACTUATOR RLY (ON/OFF)	-	×	×	ABS actuator relay signal (ON/OFF) status is displayed.
ABS FAIL SIG (ON/OFF)	-	-	×	ABS fail signal (ON/OFF) status is displayed.
EBD FAIL SIG (ON/OFF)	-	-	×	EBD fail signal (ON/OFF) status is displayed.
EBD SIGNAL (ON/OFF)	-	-	×	EBD operation (ON/OFF) status is displayed.
ABS SIGNAL (ON/OFF)	-	-	×	ABS operation (ON/OFF) status is displayed.

×: Applicable

-: Not applicable

## ACTIVE TEST

### CAUTION:

- Do not perform active test while driving.
- Make sure to completely bleed air from the brake system.
- The ABS and brake warning lamps turn on during the active test.

### Operation Procedure

1. Connect the CONSULT-III to the data link connector and start the engine.
2. Touch "ABS".  
If "ABS" is not indicated, go to [GI-36. "CONSULT-III Data Link Connector \(DLC\) Circuit"](#).
3. Touch "ACTIVE TEST".
4. The SELECT TEST ITEM screen is displayed.
5. Touch necessary test item.
6. With the "MAIN SIGNALS" display selected, touch "START".
7. The Active Test screen will be displayed, so conduct the following test.

### Solenoid Valve Operation Chart

TEST ITEM	CONDITION	JUDGEMENT		
FR RH SOL FR LH SOL RR RH SOL RR LH SOL	Ignition switch is turned ON.	Brake fluid pressure control operation		
			IN SOL	OUT SOL
		UP (Increase):	OFF	OFF
		KEEP (Hold):	ON	OFF
		DOWN (Decrease):	ON	ON

### NOTE:

- If active test is performed with brake pedal depressed, pedal stroke may change. This is normal.
- "TEST IS STOPPED" is displayed approximately 10 seconds after operation starts.
- After "TEST IS STOPPED" is displayed, to perform test again, repeat Step 6.

### ABS Motor

Touch "ON" and "OFF" on the screen. Check that ABS motor relay operates as shown in table below.

# TROUBLE DIAGNOSIS

< SERVICE INFORMATION >

[ABS]

Operation	ON	OFF
ABS actuator relay	ON	ON
ABS motor relay	ON	OFF

**NOTE:**

- If active test is performed with brake pedal depressed, pedal stroke may change. This is normal.
- "TEST IS STOPPED" is displayed approximately 10 seconds after operation starts.

A

B

C

D

E

**BRC**

G

H

I

J

K

L

M

N

O

P

# TROUBLE DIAGNOSIS FOR SELF-DIAGNOSTIC ITEMS

< SERVICE INFORMATION >

[ABS]

## TROUBLE DIAGNOSIS FOR SELF-DIAGNOSTIC ITEMS

### Wheel Sensor System

INFOID:000000004307270

#### INSPECTION PROCEDURE

##### 1. CONNECTOR INSPECTION

Disconnect the ABS actuator and electric unit (control unit) connector E33 and wheel sensor of malfunctioning code.

Check the terminals for deformation, disconnection, looseness or damage.

##### OK or NG

OK >> GO TO 2.

NG >> Repair or replace as necessary.

##### 2. CHECK WHEEL SENSOR OUTPUT SIGNAL

1. Connect ABS active wheel sensor tester (J-45741) to wheel sensor using appropriate adapter.

2. Turn on the ABS active wheel sensor tester power switch.

##### **NOTE:**

The green POWER indicator should illuminate. If the POWER indicator does not illuminate, replace the battery in the ABS active wheel sensor tester before proceeding.

3. Spin the wheel of the vehicle by hand and observe the red SENSOR indicator on the ABS active wheel sensor tester. The red SENSOR indicator should flash on and off to indicate an output signal.

##### **NOTE:**

If the red SENSOR indicator illuminates but does not flash, reverse the polarity of the tester leads and retest.

Does the ABS active wheel sensor tester detect a signal?

YES >> GO TO 3.

NO >> Replace the wheel sensor. Refer to [BRC-32. "Removal and Installation"](#).

##### 3. CHECK TIRES

Check for inflation pressure, wear and size of each tire. Refer to [WT-27](#).

Are tire pressure and size correct and is tire wear within specifications?

YES >> GO TO 4.

NO >> Adjust tire pressure or replace tire(s).

##### 4. CHECK WHEEL BEARINGS

Check wheel bearing axial end play. Refer to [FAX-6. "On-Vehicle Inspection and Service"](#) or [RAX-5. "On-Vehicle Inspection and Service"](#).

##### OK or NG

OK >> GO TO 5.

NG >> Repair or replace as necessary. Refer to [FAX-6. "Removal and Installation"](#) or [RAX-5. "Removal and Installation"](#).

##### 5. CHECK WIRING HARNESS FOR SHORT CIRCUIT

1. Disconnect ABS actuator and electric unit (control unit) connector and wheel sensor connector of malfunction code No.

2. Check continuity between wheel sensor harness connector terminals and ground.

**Continuity should not exist.**

##### OK or NG

OK >> GO TO 6.

NG >> Repair the circuit.

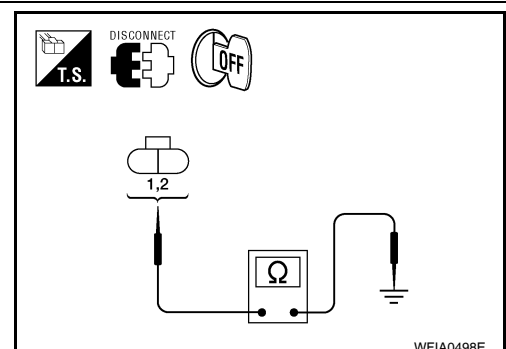

##### 6. CHECK WIRING HARNESS FOR OPEN CIRCUIT



# TROUBLE DIAGNOSIS FOR SELF-DIAGNOSTIC ITEMS

[ABS]

< SERVICE INFORMATION >

Check continuity between ABS actuator and electric unit (control unit) harness connector and wheel sensor harness connector.

Wheel sensor	ABS actuator and electric unit (control unit)		Wheel sensor		Continuity
	Connector	Terminals	Connector	Terminals	
Front LH	E33	5	E51	1	Yes
		16		2	
Front RH		10	E52	1	
		9		2	
Rear LH		17	B123	1	
		6		2	
Rear RH		19	B124	1	
		8		2	

OK or NG

- OK >> Replace the ABS actuator and electric unit (control unit). Refer to [BRC-35, "Removal and Installation"](#).
- NG >> Repair the circuit.

## ABS Control Unit Inspection

INFOID:000000004307271

INSPECTION PROCEDURE

### 1. SELF-DIAGNOSIS RESULT CHECK

Check self-diagnosis results.

Self-diagnosis results
CONTROLLER FAILURE

Is the above displayed in the self-diagnosis display items?

- YES >> Replace ABS actuator and electric unit (control unit). Refer to [BRC-35, "Removal and Installation"](#).
- NO >> Inspection End.

## Solenoid Valve System Inspection

INFOID:000000004307272

INSPECTION PROCEDURE

### 1. SELF-DIAGNOSIS RESULT CHECK

Check self-diagnosis results.

Self-diagnosis results
FR LH IN ABS SOL
FR LH OUT ABS SOL
FR RH IN ABS SOL
FR RH OUT ABS SOL
RR LH IN ABS SOL
RR LH OUT ABS SOL
RR RH IN ABS SOL
RR RH OUT ABS SOL

Is the above displayed in the self-diagnosis display items?

- YES >> GO TO 2.
- NO >> Inspection End.

# TROUBLE DIAGNOSIS FOR SELF-DIAGNOSTIC ITEMS

[ABS]

< SERVICE INFORMATION >

## 2. CONNECTOR INSPECTION

1. Disconnect ABS actuator and electric unit (control unit) connector E33.
2. Check the terminals for deformation, disconnection, looseness or damage.

OK or NG

- OK >> GO TO 3.  
 NG >> Repair or replace as necessary.

## 3. CHECKING SOLENOID POWER AND GROUND

1. Check voltage between ABS actuator and electric unit (control unit) harness connector E33 and body ground.

ABS actuator and electric unit (control unit) harness connector E33	Body ground	Measured value (Approx.)
3	—	12V

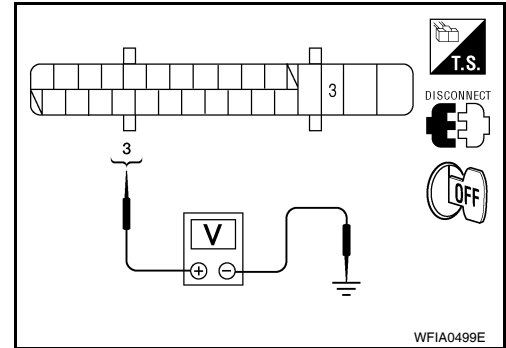

2. Check resistance between ABS actuator and electric unit (control unit) harness connector E33 and body ground.

ABS actuator and electric unit (control unit) harness connector E33	Body ground	Measured value (Approx.)
4	—	0Ω

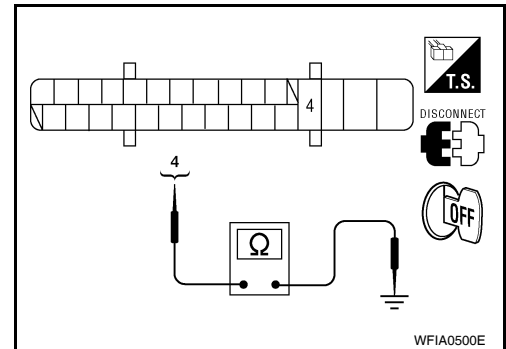

OK or NG

- OK >> Perform self-diagnosis again. If the same results appear, replace ABS actuator and electric unit (control unit). Refer to [BRC-35, "Removal and Installation"](#).  
 NG >> Repair the circuit.

## Actuator Motor, Motor Relay, and Circuit Inspection

INFOID:000000004307273

### INSPECTION PROCEDURE

#### 1. CHECKING SELF-DIAGNOSIS RESULTS

Check self-diagnosis results.

Self-diagnosis results
PUMP MOTOR
MAIN RELAY

Is the above displayed in the self-diagnosis display items?

- YES >> GO TO 2.  
 NO >> Inspection End.

#### 2. CONNECTOR INSPECTION

1. Disconnect ABS actuator and electric unit (control unit) connector E33.
2. Check the terminals for deformation, disconnection, looseness or damage.

OK or NG

- OK >> GO TO 3.  
 NG >> Repair or replace as necessary.

#### 3. CHECKING ABS MOTOR AND MOTOR RELAY POWER SYSTEM

# TROUBLE DIAGNOSIS FOR SELF-DIAGNOSTIC ITEMS

[ABS]

## < SERVICE INFORMATION >

1. Check voltage between ABS actuator and electric unit (control unit) harness connector E33 and ground.

ABS actuator and electric unit (control unit) harness connector E33	Body ground	Measured value (Approx.)
2	—	12V

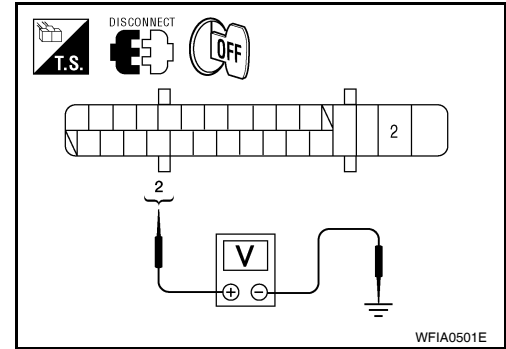

2. Check resistance between ABS actuator and electric unit (control unit) connector E33 and ground.

ABS actuator and electric unit (control unit) harness connector E33	Body ground	Measured value (Approx.)
1	—	0Ω

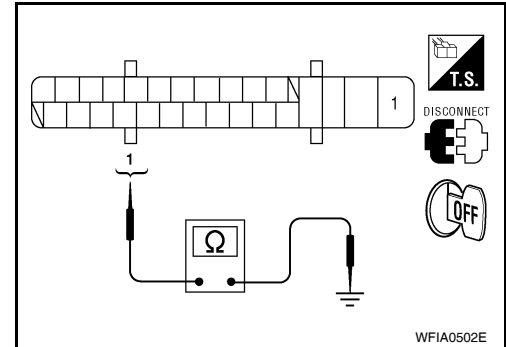

### OK or NG

- OK >> Perform self-diagnosis again. If the same results appear, replace ABS actuator and electric unit (control unit). Refer to [BRC-35, "Removal and Installation"](#).
- NG >> Repair the circuit.

## ABS Control Unit Power and Ground Systems Inspection

INFOID:000000004307274

### INSPECTION PROCEDURE

#### 1.SELF-DIAGNOSIS RESULT CHECK

Check self-diagnosis results.

Self-diagnosis results
BATTERY VOLTAGE

Is the above displayed in the self-diagnosis display items?

- YES >> GO TO 2.  
 NO >> Inspection End.

#### 2.CONNECTOR INSPECTION

1. Disconnect the ABS actuator and electric unit (control unit) connector E33.
2. Check the terminals for deformation, disconnection, looseness or damage.

### OK or NG

- OK >> GO TO 3.  
 NG >> Repair or replace as necessary.

#### 3.ABS CONTROL UNIT POWER AND GROUND CIRCUIT INSPECTION

Measure the voltage and continuity between the ABS actuator and electric unit (control unit) harness connector E33 and ground.

Signal name	ABS actuator and electric unit (control unit) harness connector E33	Body ground	Measured value
Power supply	2	—	Battery voltage (Approx. 12V)
	3		

# TROUBLE DIAGNOSIS FOR SELF-DIAGNOSTIC ITEMS

< SERVICE INFORMATION >

[ABS]

Ground	1	—	Continuity should exist.
	4		

## OK or NG

- OK >> Check the battery for loose terminals, low voltage, etc. Repair as necessary.
- NG >> Repair the circuit.

## CAN Communication System Inspection

INFOID:000000004307275

### INSPECTION PROCEDURE

#### 1. CHECK CONNECTOR

1. Turn ignition switch OFF, disconnect the ABS actuator and electric unit (control unit) connector and check the terminals for deformation, disconnection, looseness, and so on. If there is a malfunction, repair or replace the terminal.
2. Reconnect connector to perform self-diagnosis.

#### Is "CAN COMM CIRCUIT" displayed in self-diagnosis display items?

- YES >> Print out the self-diagnostic results, and refer to [LAN-17, "Trouble Diagnosis Flow Chart"](#).
- NO >> Connector terminal is loose, damaged, open, or shorted.

# TROUBLE DIAGNOSES FOR SYMPTOMS

< SERVICE INFORMATION >

[ABS]

## TROUBLE DIAGNOSES FOR SYMPTOMS

### ABS Works Frequently

INFOID:000000004307276

#### 1.CHECK WARNING LAMP ACTIVATION

Make sure warning lamp remains off while driving.

##### OK or NG

OK >> GO TO 2.

NG >> Carry out self-diagnosis. Refer to [BRC-18, "CONSULT-III Function \(ABS\)"](#).

#### 2.CHECK WHEEL SENSORS

Check the following.

- Wheel sensor mounting for looseness
- Wheel sensors for physical damage
- Wheel sensor connectors for terminal damage or loose connections
- Sensor rotor and mount for physical damage

##### OK or NG

OK >> GO TO 3.

NG >> Repair or replace as necessary.

#### 3.CHECK WHEEL BEARINGS

Check wheel bearing axial end play. Refer to [FAX-6, "On-Vehicle Inspection and Service"](#) or [RAX-5, "On-Vehicle Inspection and Service"](#).

##### OK or NG

OK >> GO TO 4.

NG >> Repair as necessary.

#### 4.CHECK BRAKE FLUID PRESSURE

Check brake fluid pressure distribution.

Refer to [BRC-16, "Basic Inspection"](#).

Is brake fluid pressure distribution normal?

YES >> Inspection End.

NO >> Perform Basic Inspection. Refer to [BRC-16, "Basic Inspection"](#).

### Unexpected Pedal Action

INFOID:000000004307277

#### 1.CHECK WARNING LAMP ACTIVATION

Make sure warning lamp remains off while driving.

##### OK or NG

OK >> GO TO 2.

NG >> Carry out self-diagnosis. Refer to [BRC-18, "CONSULT-III Function \(ABS\)"](#).

#### 2.CHECK BRAKE PEDAL STROKE

Check brake pedal stroke.

Is brake pedal stroke excessive?

YES >> Perform Basic Inspection. Refer to [BRC-16, "Basic Inspection"](#).

NO >> GO TO 3.

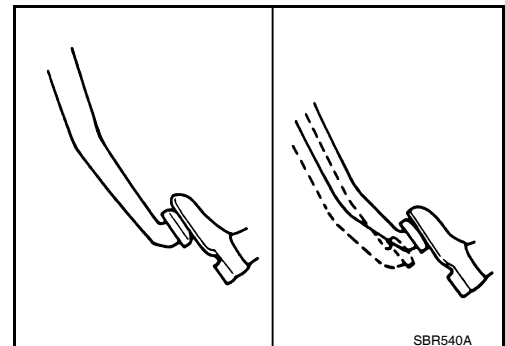

#### 3.CHECK CONNECTOR AND BRAKING PERFORMANCE

1. Disable ABS by disconnecting ABS actuator and electric unit (control unit) connector.

A  
B  
C  
D  
E  
G  
H  
I  
J  
K  
L  
M  
N  
O  
P

BRC

# TROUBLE DIAGNOSES FOR SYMPTOMS

[ABS]

## < SERVICE INFORMATION >

2. Drive vehicle and check brake operation.

**NOTE:**

- Stopping distance may be longer than vehicles without ABS when road condition is slippery.
- Driving the vehicle with the ABS actuator and electric unit (control unit) disconnected may induce DTCs in electrical control units using CAN communication. After the inspection, clear all DTCs. Refer to [LAN-8, "System Description"](#).

OK or NG

OK >> GO TO 4.

NG >> Perform Basic Inspection. Refer to [BRC-16, "Basic Inspection"](#).

## 4. CHECK WHEEL SENSORS

Check the following.

- Wheel sensor mounting for looseness
- Wheel sensors for physical damage
- Wheel sensor connectors for terminal damage or loose connections
- Sensor rotor and mount for physical damage

OK or NG

OK >> Check ABS actuator and electric unit (control unit) connector terminals for deformation, disconnection, looseness or damage. Reconnect ABS actuator and electric unit (control unit) harness connector. Then retest.

NG >> Repair or replace as necessary.

## Long Stopping Distance

INFOID:000000004307278

### 1. CHECK BASE BRAKING SYSTEM PERFORMANCE

1. Disable ABS by disconnecting ABS actuator and electric unit (control unit) connector.

2. Drive vehicle and check brake operation.

**NOTE:**

- Stopping distance may be longer than vehicles without ABS when road condition is slippery.
- Driving the vehicle with the ABS actuator and electric unit (control unit) disconnected may induce DTCs in electrical control units using CAN communication. After the inspection, clear all DTCs. Refer to [LAN-8, "System Description"](#).

OK or NG

OK >> Go to [BRC-29, "ABS Works Frequently"](#).

NG >> Perform Basic Inspection. Refer to [BRC-16, "Basic Inspection"](#).

## ABS Does Not Work

INFOID:000000004307279

**CAUTION:**

The ABS does not operate when the vehicle speed is 10 km/h (6 MPH) or less.

### 1. CHECK WARNING LAMP ACTIVATION

Turn ignition switch ON and check for warning lamp activation.

- Warning lamp should activate for approximately 2 seconds after turning the ignition switch ON.

OK or NG

OK >> Carry out self-diagnosis. Refer to [BRC-18, "CONSULT-III Function \(ABS\)"](#).

NG >> Go to [BRC-16, "Basic Inspection"](#).

## Pedal Vibration or ABS Operation Noise

INFOID:000000004307280

**NOTE:**

During ABS activation, pedal vibration may be felt and a noise may be heard. This is normal and does not indicate a malfunction.

### 1. CHECK SYMPTOM

1. Apply brake.

2. Start engine.

Does the symptom occur only when engine is started?

YES >> Carry out self-diagnosis. Refer to [BRC-18, "CONSULT-III Function \(ABS\)"](#).

# TROUBLE DIAGNOSES FOR SYMPTOMS

[ABS]

< SERVICE INFORMATION >

NO >> GO TO 2.

## 2.RECHECK SYMPTOM

Does the symptom occur only when electrical equipment switches (such as headlamps) are turned on?

YES >> Check for radio, antenna or related wiring that is routed too close to the ABS actuator and electric unit (control unit) and reroute as necessary.

NO >> Go to [BRC-29, "ABS Works Frequently"](#).

A

B

C

D

E

**BRC**

G

H

I

J

K

L

M

N

O

P

# WHEEL SENSORS

< SERVICE INFORMATION >

[ABS]

## WHEEL SENSORS

### Removal and Installation

INFOID:000000004307281

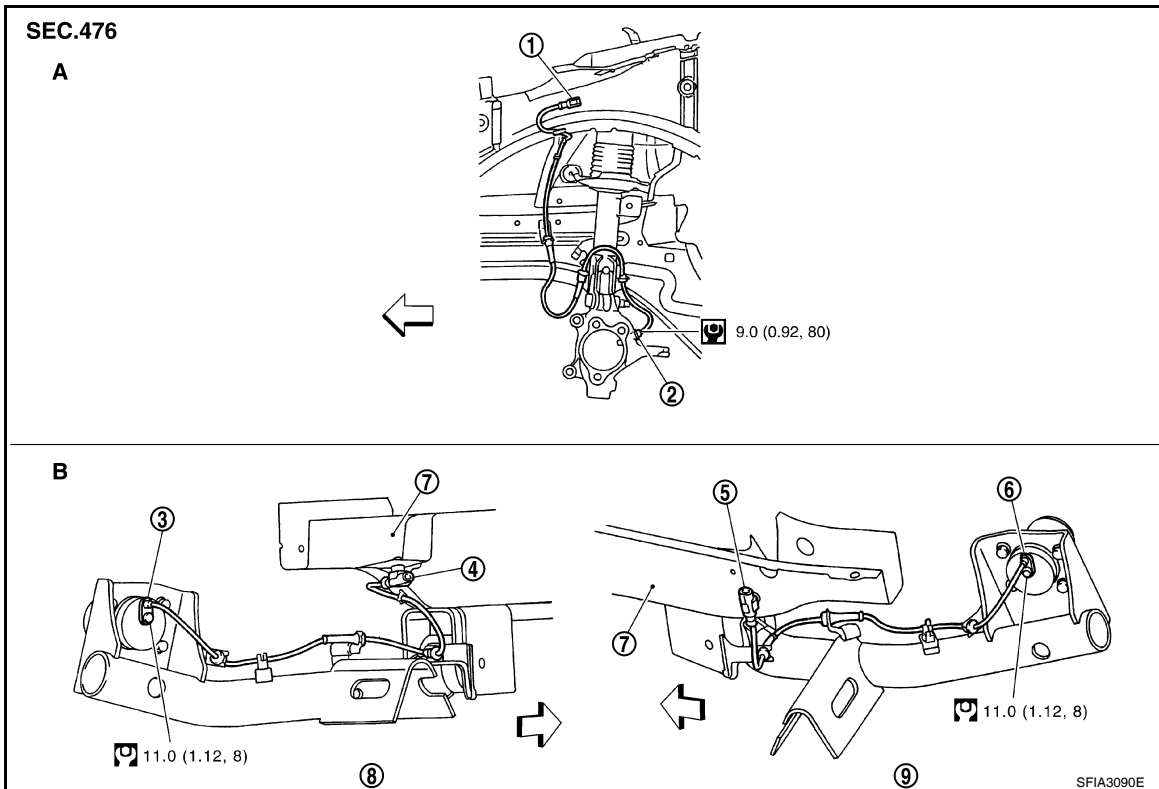

- |                                     |                           |                                      |
|-------------------------------------|---------------------------|--------------------------------------|
| A. Front                            | B. Rear                   | 1. Front wheel sensor connector (LH) |
| 2. Front wheel sensor (LH)          | 3. Rear wheel sensor (LH) | 4. Rear wheel sensor connector (LH)  |
| 5. Rear wheel sensor connector (RH) | 6. Rear wheel sensor (RH) | 7. Side member                       |
| 8. LH side                          | 9. RH side                | Front                                |

#### NOTE:

The top portion of the figure (front side) shows the view from LH side of the vehicle. The RH side is the mirror image of the LH side.

### FRONT WHEEL SENSOR

#### Removal

#### CAUTION:

- As much as possible, avoid rotating wheel sensor when removing it. Pull wheel sensors out without pulling on sensor harness.
- Take care to avoid damaging wheel sensor edges or rotor teeth. Remove wheel sensor first before removing front or rear wheel hub. This is to avoid damage to wheel sensor wiring and loss of sensor function.

1. Remove the front wheel and tire. Refer to [WT-7, "Rotation"](#).
2. Remove the front fender protector. Refer to [EI-24, "Removal and Installation"](#).
3. Disconnect the front wheel sensor connector.
4. Remove the front wheel sensor.

#### Installation

Installation is in the reverse order of removal.

#### CAUTION:

- When installing, make sure there is no foreign material such as iron chips on and in the mounting hole of the wheel sensor. Make sure no foreign material has been caught in the sensor rotor. Remove any foreign material and clean the mount.



# WHEEL SENSORS

[ABS]

< SERVICE INFORMATION >

- When installing front wheel sensor, press rubber grommets of strut bracket and body all the way in until they get locked, and be careful not to apply a twist to harness. Harness should not be twisted after installation. (Install it with harness paint mark on body side grommet facing front of vehicle, and the strut side grommet facing outside of vehicle.)

A

## REAR WHEEL SENSOR

B

Removal

### CAUTION:

- As much as possible, avoid rotating wheel sensor when removing it. Pull wheel sensors out without pulling on sensor harness.
- Take care to avoid damaging wheel sensor edges or rotor teeth. Remove wheel sensor first before removing front or rear wheel hub. This is to avoid damage to wheel sensor wiring and loss of sensor function.

C

1. Disconnect the rear wheel sensor connector.
2. Remove the rear wheel sensor.

D

E

Installation

Installation is in the reverse order of removal.

### CAUTION:

- When installing, make sure there is no foreign material such as iron chips on and in the mounting hole of the wheel sensor. Make sure no foreign material has been caught in the sensor rotor. Remove any foreign material and clean the mount.
- When installing rear wheel sensor, press rubber grommets of suspension arm bracket and harness of side member all the way in until they get locked, and be careful not to apply a twist to harness. Harness should not be twisted after installation. (Aim the paint mark upward of vehicle.)

BRC

G

H

I

J

K

L

M

N

O

P

# SENSOR ROTOR

< SERVICE INFORMATION >

[ABS]

---

## SENSOR ROTOR

### Removal and Installation

INFOID:000000004307282

The front and rear sensor rotors are part of the hub bearing assembly and cannot be removed separately. To replace the front or rear sensor rotors, the hub bearing assembly must be replaced. Refer to [FAX-6. "Removal and Installation"](#) (front axle), [RAX-5. "Removal and Installation"](#) (rear axle).

# ACTUATOR AND ELECTRIC UNIT (ASSEMBLY)

< SERVICE INFORMATION >

[ABS]

## ACTUATOR AND ELECTRIC UNIT (ASSEMBLY)

### Removal and Installation

INFOID:00000004307283

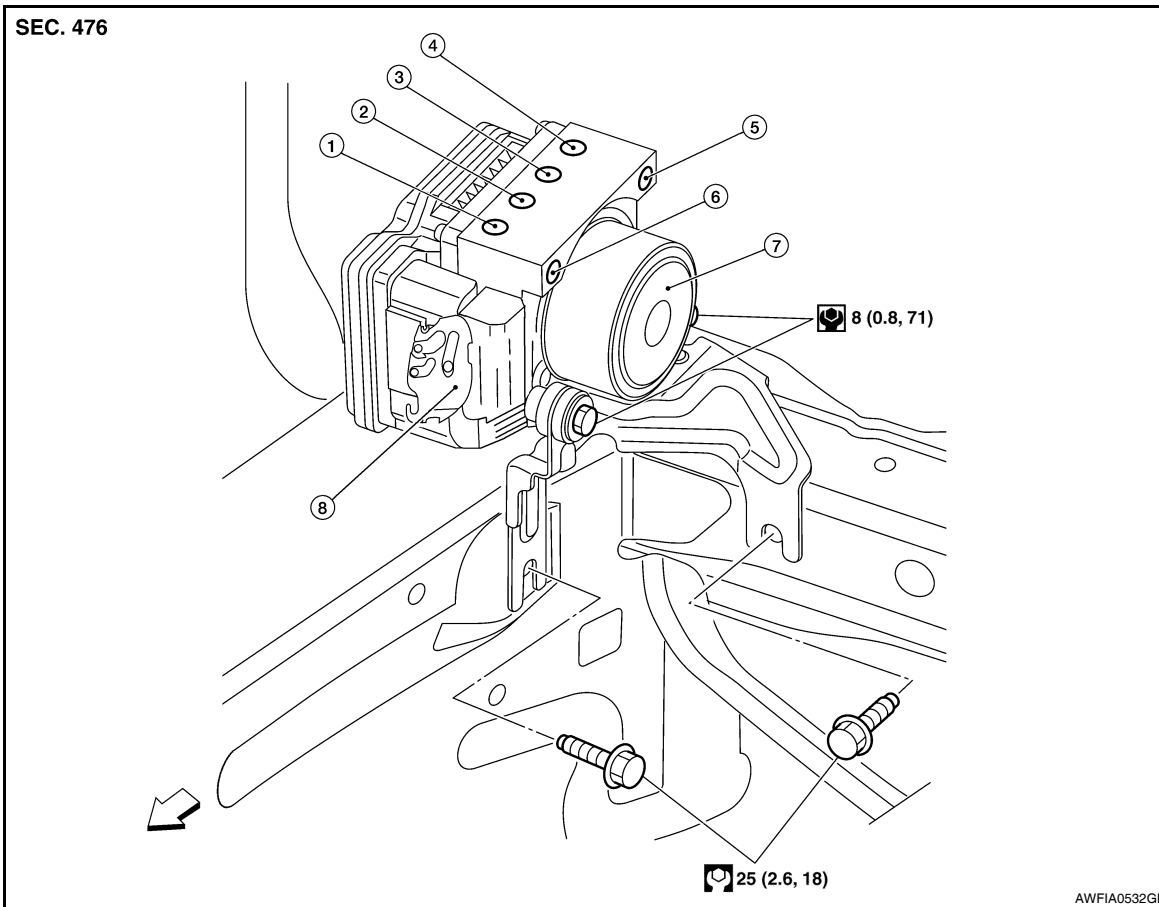

- |  |                                      |  |
|--|--------------------------------------|--|
| 1. To front right caliper                        | 2. To rear left wheel cylinder       | 3. To rear right wheel cylinder        |
| 4. To front left caliper                         | 5. From master cylinder primary side | 6. From master cylinder secondary side |
| 7. ABS actuator and electric unit (control unit) | 8. Harness connector                 | ■ Front                                |

#### CAUTION:

- Before servicing, disconnect battery negative terminal.
- To remove brake tube, use flare nut wrench to prevent flare nuts and brake tube from being damaged. To install, use flare nut torque wrench, tighten flare nut to the specified torque. Refer to [BR-11, "Hydraulic Circuit"](#).
- Do not apply excessive impact to ABS actuator and electric unit (control unit), such as dropping it.
- Do not remove and install actuator by holding harness.
- After work is completed, bleed the air from the brake hydraulic system. Refer to [BR-9, "Bleeding Brake System"](#).

#### REMOVAL

1. Disconnect the battery negative terminal.
2. Remove the cowl top. Refer to [EI-22, "Removal and Installation"](#).
3. Disconnect ABS actuator and electric unit (control unit) connector.
4. Loosen brake tube flare nuts, then remove brake tubes from ABS actuator and electric unit (control unit).
5. Remove brake booster hose from engine. Refer to [BR-23, "Removal and Installation"](#).
6. Remove ABS actuator and electric unit (control unit) bracket bolts.
7. Remove ABS actuator and electric unit (control unit).

## ACTUATOR AND ELECTRIC UNIT (ASSEMBLY)

< SERVICE INFORMATION >

[ABS]

---

### INSTALLATION

Installation is in the reverse order of removal.

- Bleed the brake system. Refer to [BR-9, "Bleeding Brake System"](#).

#### **CAUTION:**

**After installing harness connector in the ABS actuator and electric unit (control unit), make sure the connector is securely locked.**