

# SECTION TF

## CONTENTS

<b>PREPARATION</b> .....	2	<b>DISASSEMBLY</b> .....	13
Special Service Tools .....	2	<b>REPAIR FOR COMPONENT PARTS</b> .....	18
Commercial Service Tools .....	3	Mainshaft .....	18
<b>NOISE, VIBRATION AND HARSHNESS (NVH)</b>		Front Drive Shaft .....	20
<b>TROUBLESHOOTING</b> .....	4	Counter Gear .....	21
NVH Troubleshooting Chart.....	4	Main Gear .....	21
Transfer .....	4	Front Case .....	23
<b>DESCRIPTION</b> .....	5	Shift Shaft Oil Seal.....	23
Cross-sectional View .....	5	Front Case Cover .....	23
<b>ON-VEHICLE SERVICE</b> .....	6	Cover Oil Seal.....	23
Replacing Oil Seal .....	6	Bearing Retainer.....	24
Center Case Oil Seal .....	6	Oil Catcher .....	24
Shift Shaft Oil Seal.....	6	Rear Case.....	24
Rear Oil Seal.....	7	Rear Oil Seal.....	24
<b>REMOVAL AND INSTALLATION</b> .....	8	Air Breather .....	24
<b>TRANSFER GEAR CONTROL</b> .....	9	Shift Control Components .....	25
<b>MAJOR OVERHAUL</b> .....	10	<b>ASSEMBLY</b> .....	26
Case Components .....	10	<b>SERVICE DATA AND SPECIFICATIONS (SDS)</b> .....	33
Gear Components .....	11	General Specifications.....	33
Shift Control Components .....	12	Inspection and Adjustment .....	33

GI

MA

EM

LC

EC

FE

CL

MT

AT

TF

PD

FA

RA

BR

ST

RS

BT

HA

EL

IDX

# PREPARATION

## Special Service Tools

The actual shapes of Kent-Moore tools may differ from those of special service tools illustrated here.

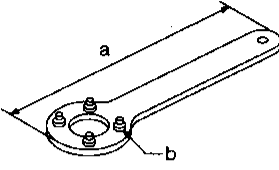
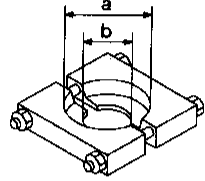
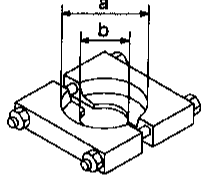
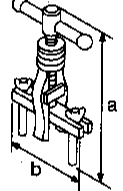
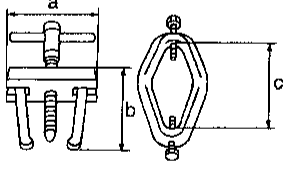
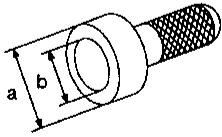
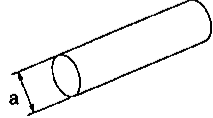
Tool number (Kent-Moore No.) Tool name	Description	
ST38060002 (J34311) Flange wrench	 <p style="text-align: center;">NT428</p>	Removing companion flange nut Installing companion flange nut  <b>a: 480 mm (18.90 in)</b> <b>b: Pitch dia.: 75 mm (2.95 in)</b> <b>Pin dia.: 10 mm (0.39 in)</b>
ST30021000 (J22912-01) Puller	 <p style="text-align: center;">NT411</p>	Removing counter gear front bearing (Use with ST36710010) Removing L & H hub  <b>a: 110 mm (4.33 in) dia.</b> <b>b: 68 mm (2.68 in) dia.</b>
ST30031000 (J22912-01) Puller	 <p style="text-align: center;">NT411</p>	Removing counter gear rear bearing (Use with ST36710010)  <b>a: 90 mm (3.54 in) dia.</b> <b>b: 50 mm (1.97 in) dia.</b>
ST33290001 (J34286) Puller	 <p style="text-align: center;">NT414</p>	Removing center case oil seal Removing rear oil seal  <b>a: 250 mm (9.84 in)</b> <b>b: 160 mm (6.30 in)</b>
ST33051001 (J22888) Puller	 <p style="text-align: center;">NT657</p>	Removing companion flange  <b>a: 135 mm (5.31 in)</b> <b>b: 100 mm (3.94 in)</b> <b>c: 130 mm (5.12 in)</b>
ST30720000 ① (J25273) ② (J25405) Drift	 <p style="text-align: center;">NT115</p>	① Installing center case oil seal ② Installing rear oil seal  <b>a: 77 mm (3.03 in) dia.</b> <b>b: 55.5 mm (2.185 in) dia.</b>
ST36710010 ( — ) Drift	 <p style="text-align: center;">NT063</p>	Removing counter gear front bearing (Use with ST30021000) Removing counter gear rear bearing (Use with ST30031000)  <b>a: 34.5 mm (1.358 in) dia.</b>

## PREPARATION

### Special Service Tools (Cont'd)

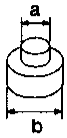
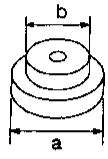
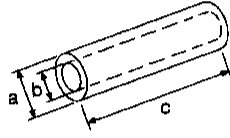
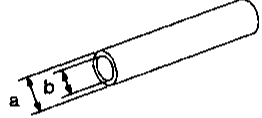
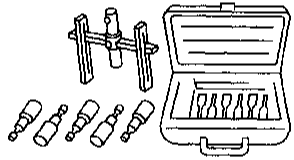
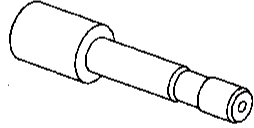
Tool number (Kent-Moore No.) Tool name	Description	
ST33061000 (J8107-2) Drift	NT116	 <p>Removing main gear bearing</p> <p>a: 28.5 mm (1.122 in) dia. b: 38 mm (1.50 in) dia.</p>
ST30613000 ① (J25742-3) ② (J34339) Drift	NT073	 <p>① Installing main gear bearing (Use with ST30611000) ② Installing cover oil seal (Use with ST30611000)</p> <p>a: 72 mm (2.83 in) dia. b: 48 mm (1.89 in) dia.</p>
(J35864) Drift	NT117	 <p>Installing shift shaft oil seal</p> <p>a: 26 mm (1.02 in) dia. b: 20 mm (0.79 in) dia. c: 150 mm (5.91 in)</p>
(J26092) Drift	NT065	 <p>Seating counter gear assembly</p> <p>a: 44.5 mm (1.752 in) dia. b: 38.5 mm (1.516 in) dia.</p>
(J34291) Shim setting gauge set	NT101	 <p>Selecting counter gear rear bearing shim</p>
(J34291-20) Plunger-shim setting gauge	NT118	 <p>Selecting counter gear rear bearing shim</p>

### Commercial Service Tools

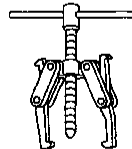
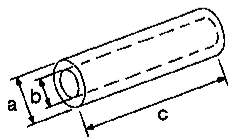
Tool name	Description	
Puller	NT077	 <p>Removing front drive shaft front bearing Removing front drive shaft rear bearing Removing main gear bearing Removing companion flange</p>
Drift	NT117	 <p>① Installing mainshaft rear bearing ② Installing L &amp; H hub</p> <p>① a: 50 mm (1.97 in) dia. b: 42 mm (1.65 in) dia. c: 180 mm (7.09 in) ② a: 60 mm (2.36 in) dia. b: 50 mm (1.97 in) dia. c: 60 mm (2.36 in)</p>

# NOISE, VIBRATION AND HARSHNESS (NVH) TROUBLESHOOTING

## NVH Troubleshooting Chart

Use the chart below to help you find the cause of the symptom. The numbers indicate the order of inspection. If necessary, repair or replace these parts.

### TRANSFER

Reference page		Refer to MA section ("Checking Transfer Fluid", "CHASSIS AND BODY MAINTENANCE").										
SUSPECTED PARTS (Possible cause)		FLUID (Level low)	FLUID (Wrong)	FLUID (Level too high)	LIQUID GASKET (Damaged)	OIL SEAL (Worn or damaged)	CHECK SPRING AND CHECK BALL (Worn or damaged)	SHIFT FORK (Worn)	GEAR (Worn or damaged)	BEARING (Worn or damaged)	BAULK RING (Worn or damaged)	SHIFTING INSERT (Damaged)
Symptom	Noise	1	2						3	3		
	Fluid leakage		3	1	2	2						
	Hard to shift or will not shift		1	1							2	2
	Jumps out of gear						1	2	2			
Reference page					TF-10	TF-10	TF-10, 12	TF-12	TF-11	TF-11	TF-11	TF-11

# DESCRIPTION

## Cross-sectional View

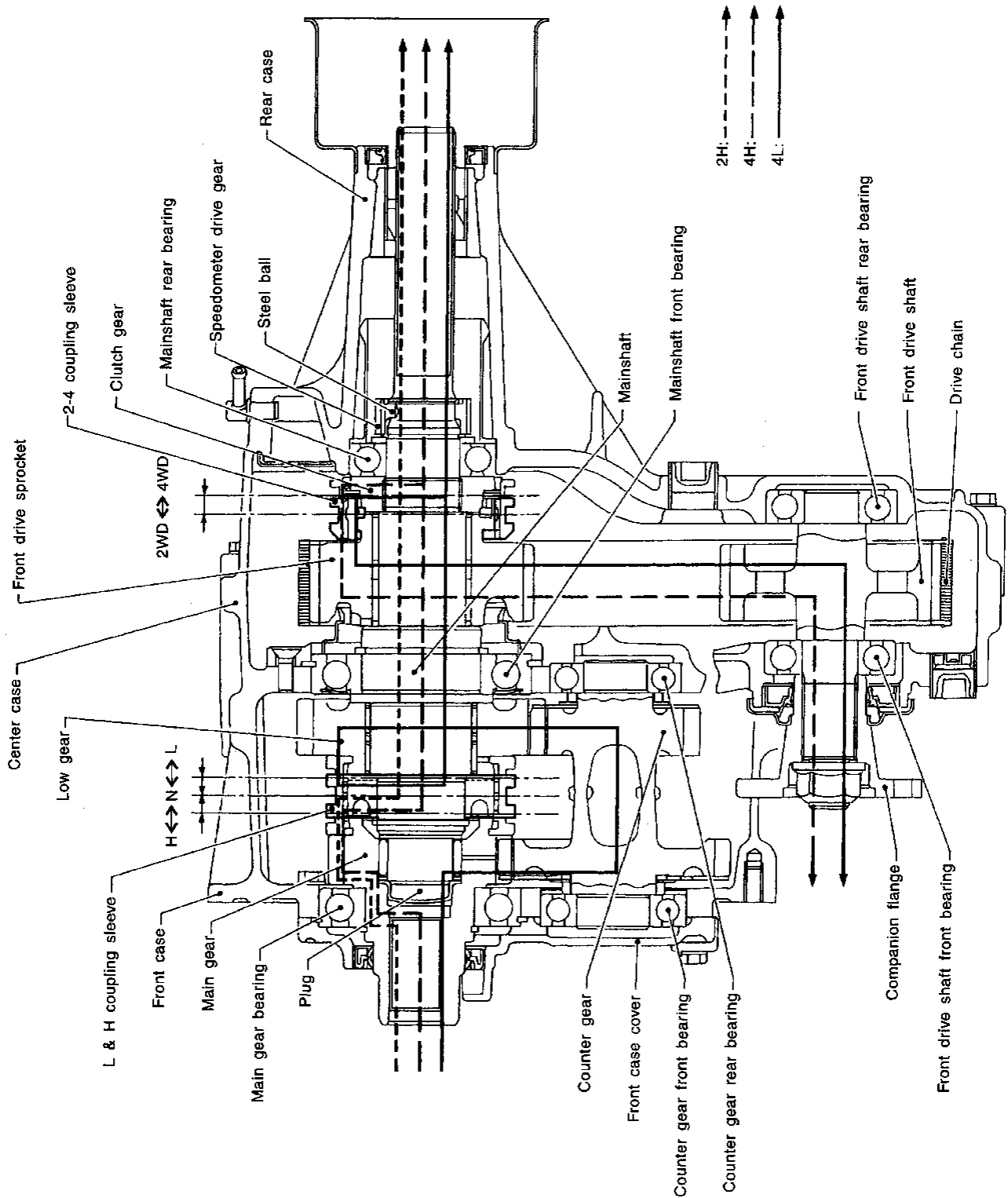

GI  
MA  
EM  
LC  
EC  
FE  
CL  
MT  
AT  
TF  
PD  
FA  
RA  
BR  
ST  
RS  
BT  
HA  
EL  
IDX

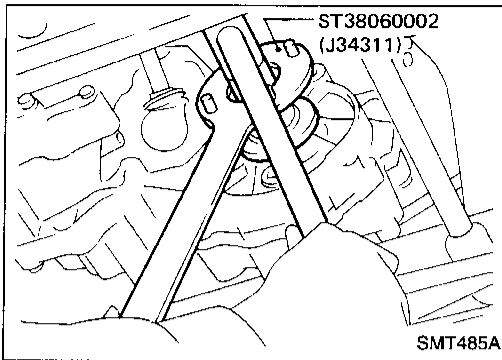

## Replacing Oil Seal

### CENTER CASE OIL SEAL

1. Remove front propeller shaft. Refer to PD section ("Removal and Installation", "PROPELLER SHAFT").
2. Remove companion flange nut.

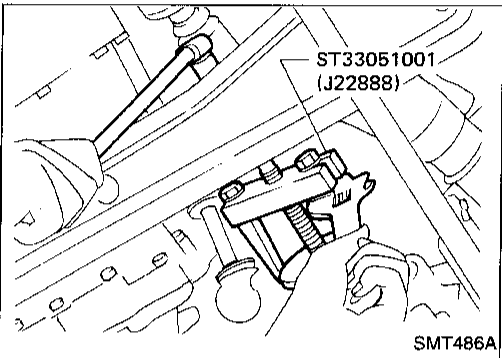

3. Remove companion flange.

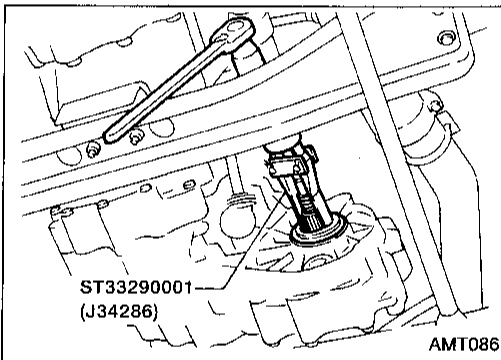

4. Remove center case oil seal.
5. Install center case oil seal.
  - **Before installing, apply multi-purpose grease to seal lip.**
6. Install companion flange.

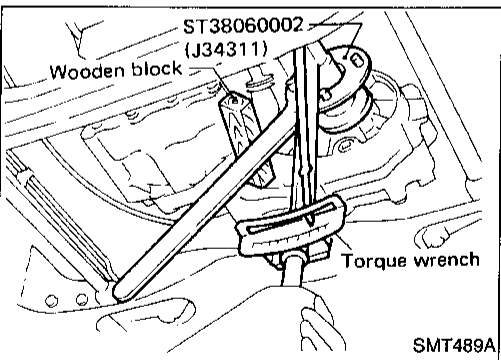

7. Tighten companion flange nut.

: **226 - 324 N·m (23 - 33 kg·m, 166 - 239 ft·lb)**

8. Install front propeller shaft. Refer to PD section ("Removal and Installation", "PROPELLER SHAFT").

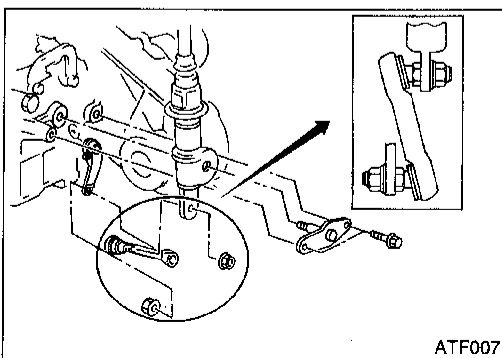

### SHIFT SHAFT OIL SEAL

1. Remove front propeller shaft. Refer to PD section ("Removal and Installation", "PROPELLER SHAFT").
2. Remove companion flange. Refer to "CENTER CASE OIL SEAL", above.
3. Remove transfer control lever from transfer outer shift lever. Then remove outer shift lever.

## ON-VEHICLE SERVICE

### Replacing Oil Seal (Cont'd)

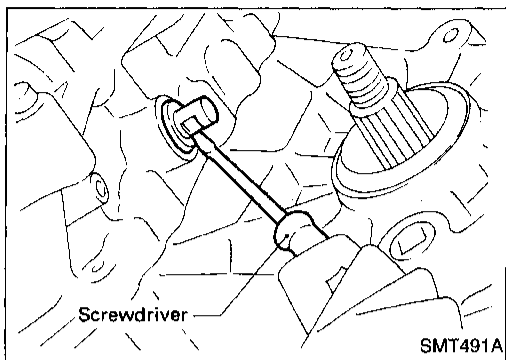

4. Remove shift shaft oil seal.
  - **Be careful not to damage cross shaft.**

GI

MA

EM

LC

EC

FE

CL

MT

AT

TF

PD

FA

RA

BR

ST

RS

BT

HA

EL

IDX

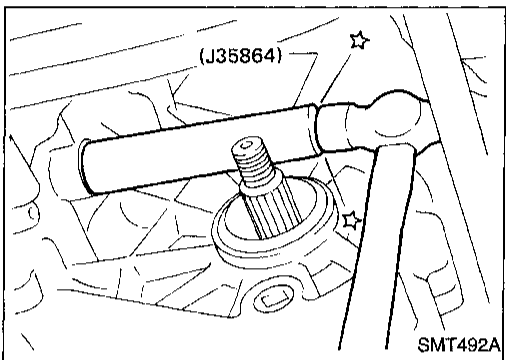

5. Install shift shaft oil seal.
  - **Before installing, apply multi-purpose grease to seal lip.**
6. Install transfer control linkage.
7. Install companion flange. Refer to "CENTER CASE OIL SEAL", TF-6.
8. Install front propeller shaft. Refer to PD section ("Removal and Installation", "PROPELLER SHAFT").

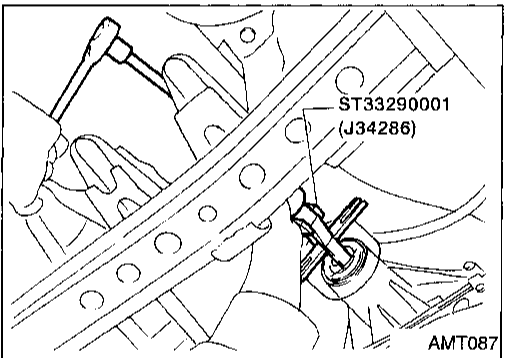

### REAR OIL SEAL

1. Remove rear propeller shaft. Refer to PD section ("Removal and Installation", "PROPELLER SHAFT").
2. Remove rear oil seal.

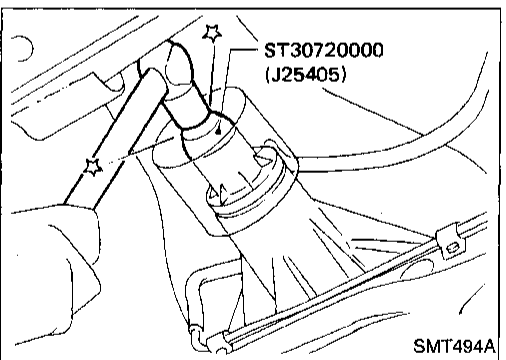

3. Install rear oil seal.
  - **Before installing apply multi-purpose grease to seal lip.**
4. Install rear propeller shaft. Refer to PD section ("Removal and Installation", "PROPELLER SHAFT").

# REMOVAL AND INSTALLATION

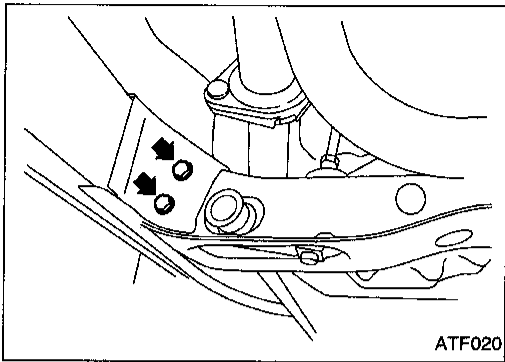

ATF020

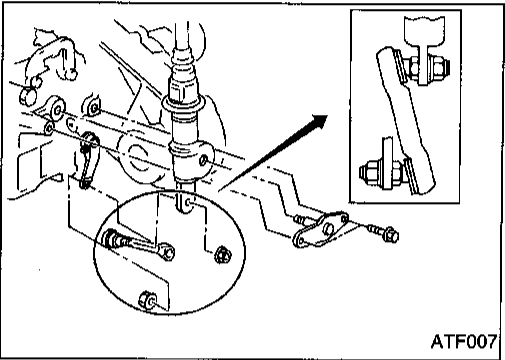

ATF007

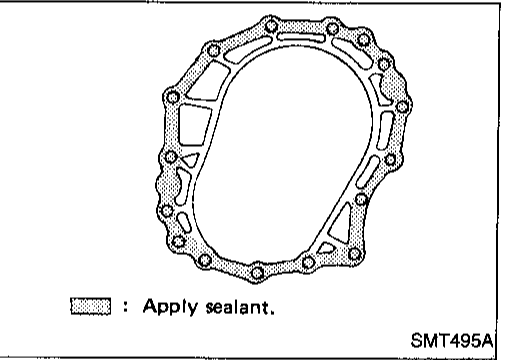

SMT495A

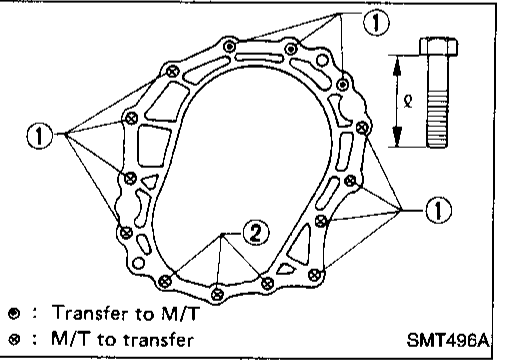

SMT496A

## Removal

1. Drain oil from transfer and transmission.
2. Remove front and rear propeller shaft. Refer to PD section ("Removal and Installation", "PROPELLER SHAFT"). Insert plug into rear oil seal after removing propeller shaft.
  - **Be careful not to damage spline, sleeve yoke and rear oil seal, when removing propeller shaft.**
3. Remove torsion bar spring. Refer to FA section ("Torsion Bar Spring", "FRONT SUSPENSION"). Then remove second crossmember.
4. Remove exhaust front and rear tubes. Refer to FE section ("EXHAUST SYSTEM").
5. Disconnect vehicle speed sensor, transfer neutral position switch and 4WD switch harness connectors.
6. Remove air breather hose.
7. Remove transfer control lever from transfer outer shift lever.
8. Separate transfer from transmission.

### WARNING:

**Support transfer while removing it.**

## Installation

- Apply sealant to mating surface of transfer case to transmission.
- **Use genuine anaerobic liquid gasket, Three Bond TB1215, Loctite Part No. 51813 or equivalent.**

- Tighten bolts securing transfer.

Bolt No.	Tightening torque N·m (kg·m, ft·lb)	ℓ mm (in)
①	31 - 41 (3.2 - 4.2, 23 - 30)	45 (1.77)
②	31 - 41 (3.2 - 4.2, 23 - 30)	60 (2.36)



# TRANSFER GEAR CONTROL

SEC. 333

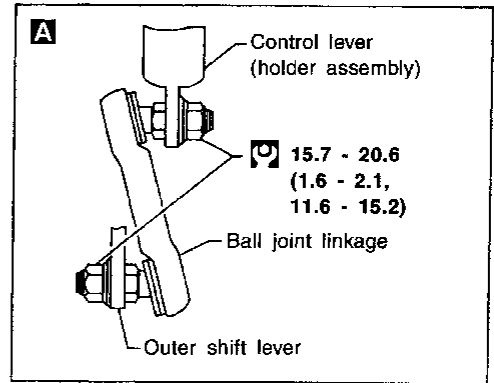
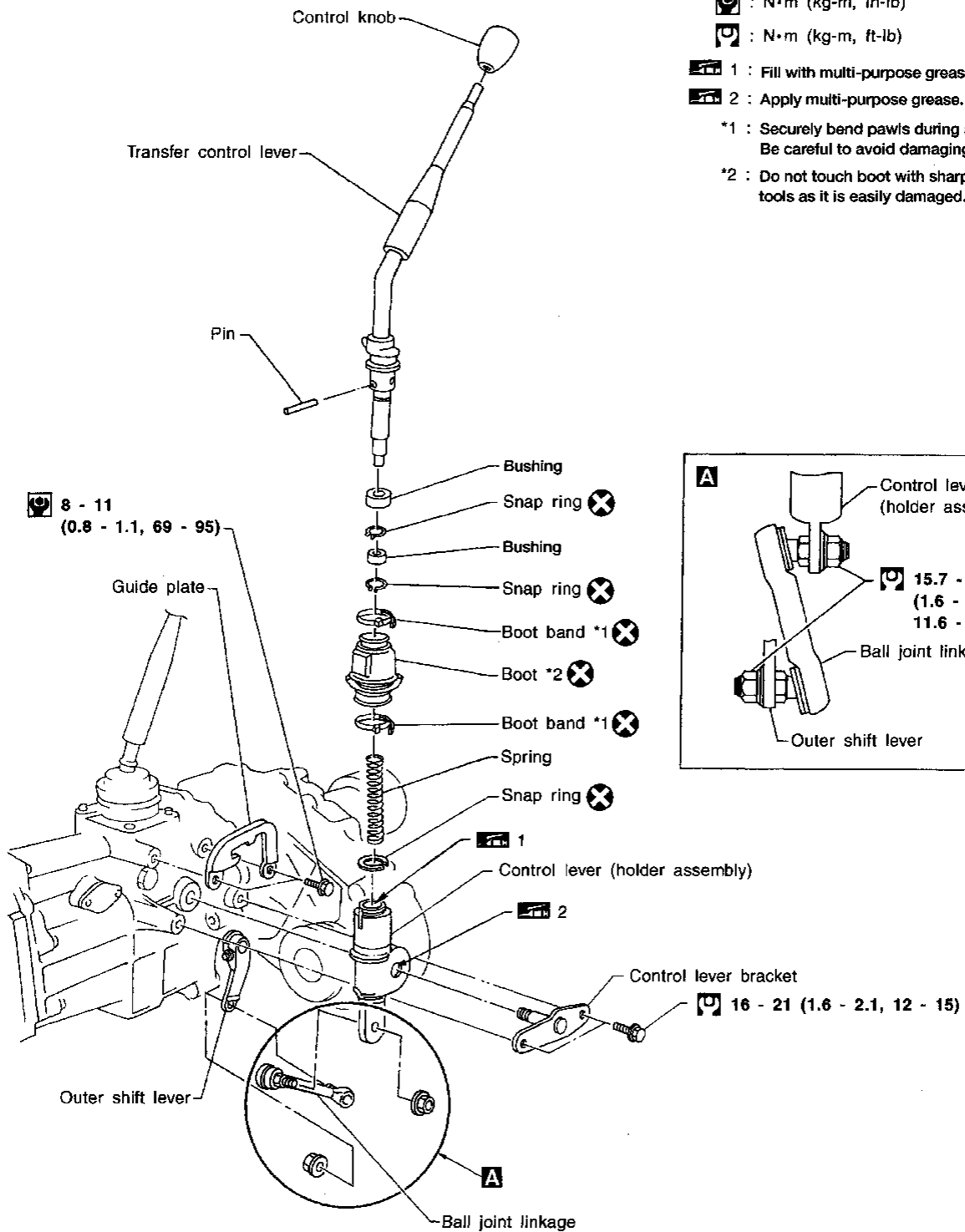

GI  
MA  
EM  
LC  
EC  
FE  
CL  
MT  
AT  
TF  
PD  
FA  
RA  
BR  
ST  
RS  
BT  
HA  
EL  
IDX

# MAJOR OVERHAUL

## Case Components

SEC. 331

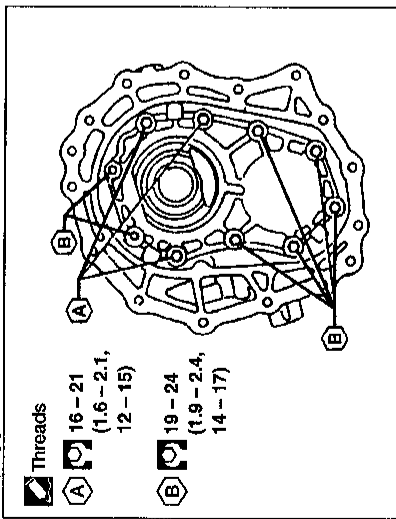

Threads

**A** 16-21  
(1.6-2.1,  
12-15)

**B** 19-24  
(1.9-2.4,  
14-17)

4WD switch  
Threads

15-20 (1.5-2.0, 11-14)

Rear oil seal Seal lip

Air breather

Breather cover

3.7 - 5.0 (0.38 - 0.51, 33.0 - 44.3)

Transfer neutral position switch  
Threads

15-20 (1.5-2.0, 11-14)

Oil gutter

Knock pin

Dust cover

Filler plug  
Threads 25-34  
(2.5-3.5,  
18-25)

Check balls

Shift shaft  
oil seal Seal lip

Drain plug  
Threads

25-34 (2.5-3.5, 18-25)

Center case  
Mating surface to front case

26-36  
(2.7-3.7, 20-27)

Rear case  
Mating surface to center case

26-36  
(2.7-3.7, 20-27)

Center case  
Mating surface to front case

26-36  
(2.7-3.7, 20-27)

Center case oil seal Seal lip

25-34 (2.5-3.5, 18-25)

Seal lip

Front case cover  
Mating surface to front case

26-36  
(2.7-3.7, 20-27)

Cover oil seal Seal lip

Front case  
Mating surface to transmission

26-36  
(2.7-3.7, 20-27)

: N·m (kg-m, in-lb)

: N·m (kg-m, ft-lb)

: Apply genuine anaerobic liquid gasket, Three Bond TB1215, Loctite Part No. 51813 or equivalent.

: Apply genuine locking sealant, Three Bond TB1324, Loctite 271 or equivalent.

# MAJOR OVERHAUL

## Gear Components

SEC. 332

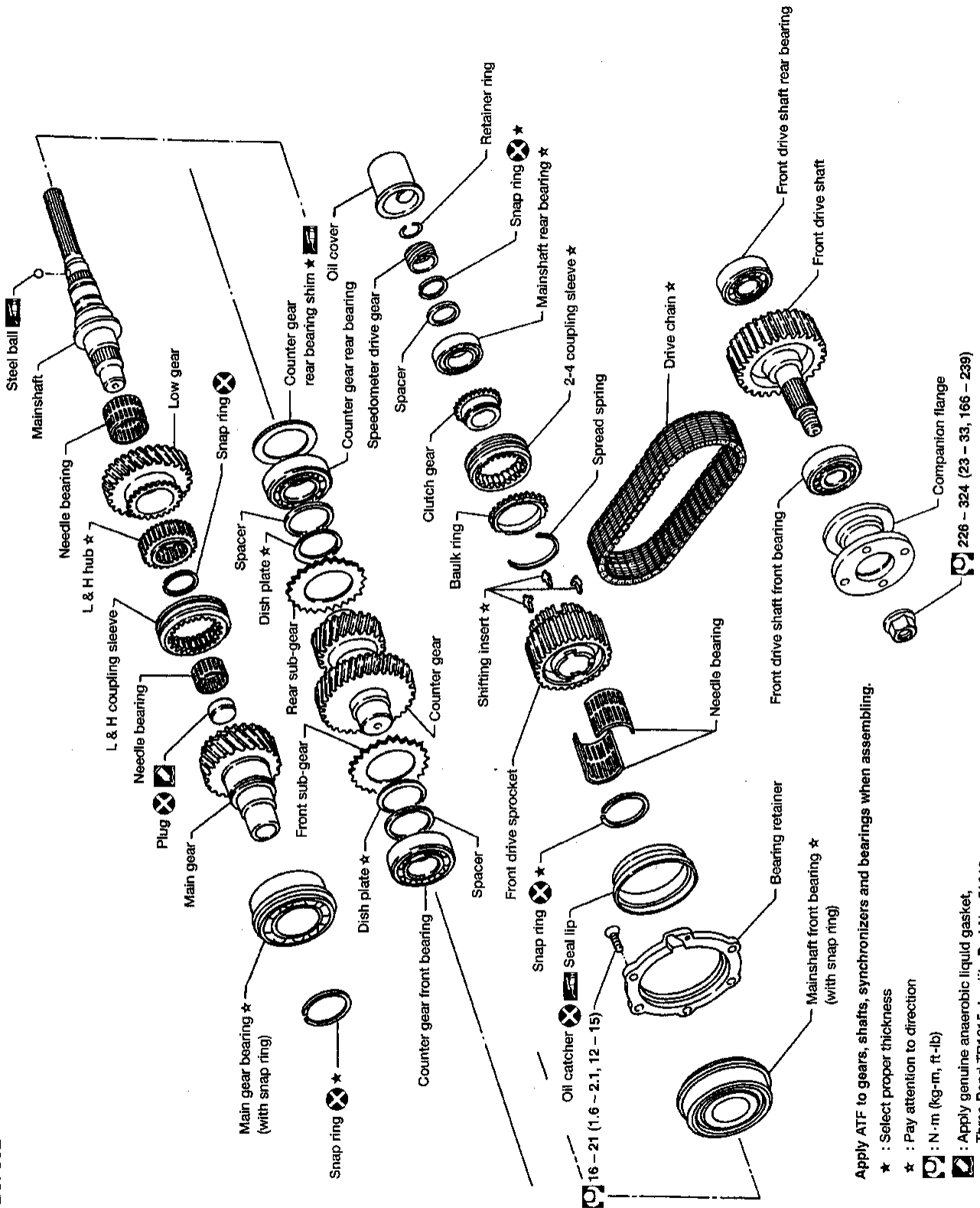

Apply ATF to gears, shafts, synchronizers and bearings when assembling.

★ : Select proper thickness

★ : Pay attention to direction

☒ : N·m (kg-m, ft-lb)

☒ : Apply genuine anaerobic liquid gasket.

Three Bond TB1215, Loctite Part No. 51813 or equivalent.

GI  
MA  
EM  
LC  
EC  
FE  
CL  
MT  
AT  
TF  
PD  
FA  
RA  
BR  
ST  
RS  
BT  
HA  
EL  
IDX

# MAJOR OVERHAUL

## Shift Control Components

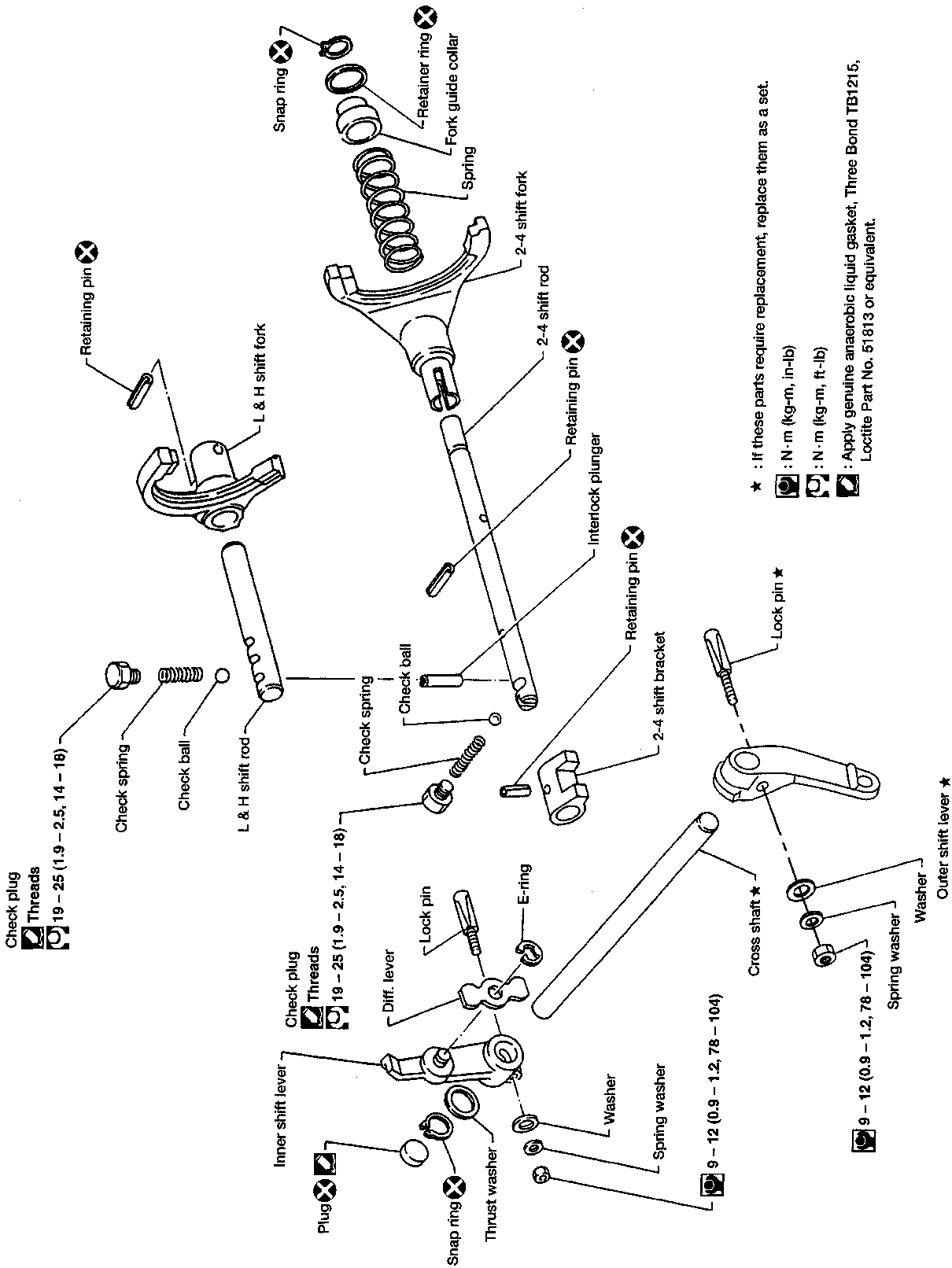

SEC. 333

## DISASSEMBLY

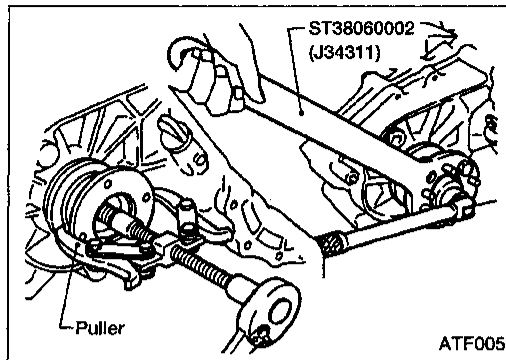

1. Remove companion flange nut.
2. Remove companion flange.

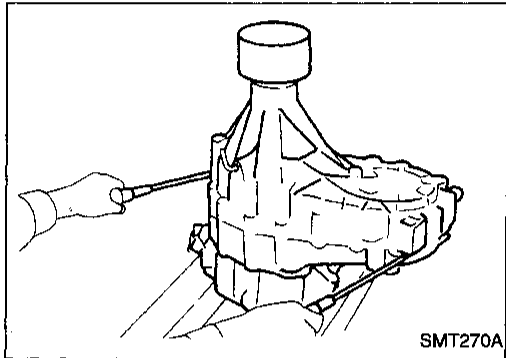

3. Remove 4WD switch and vehicle speed sensor.
4. Remove rear case.
  - **Be careful not to damage the mating surface.**

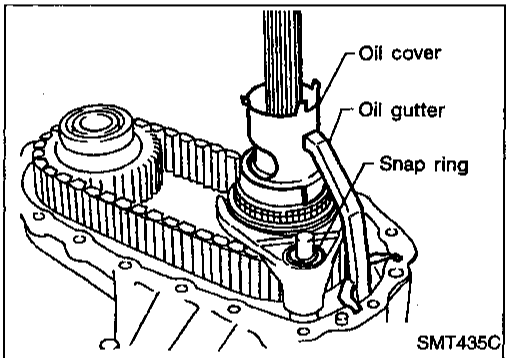

5. Remove oil cover and oil gutter.
6. Remove snap ring from 2-4 shift rod.

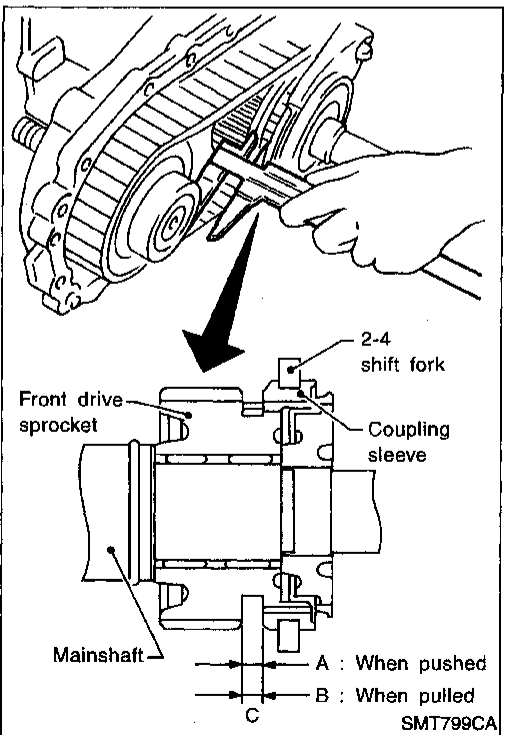

7. Using calipers, measure the difference between front drive sprocket and 2-4 coupling sleeve as outlined under Measuring method below. If it is outside specifications, check front drive sprocket, 2-4 coupling sleeve, clutch gear, 2-4 shift fork and 2-4 fork rod for abnormalities. Replace faulty part(s) as required.

### Measuring method

- a. Move coupling sleeve until it is in contact with sprocket, then measure dimension A. Move coupling sleeve until it is in contact with clutch gear, then measure dimension B. Obtain dimensional difference C between two measurements A and B.

$$C = A - B$$

- b. To determine dimension A, measure at 3 or 4 different points by rotating sprocket and obtain average value of 3 or 4 measurements.

**Specification C:**  
Refer to TF-33.

GI  
MA  
EM  
LC  
EC  
FE  
CL  
MT  
AT  
TF  
PD  
FA  
RA  
BR  
ST  
RS  
BT  
HA  
EL  
IDX

## DISASSEMBLY

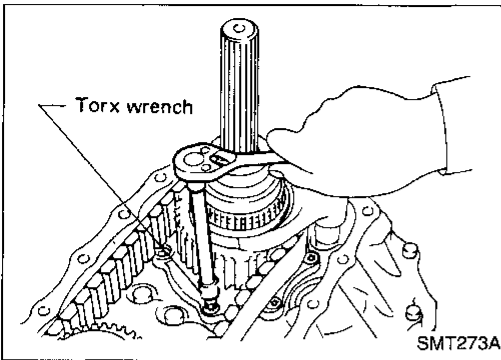

8. Remove bolts securing bearing retainer.
  - **This step is necessary to remove mainshaft from center case.**

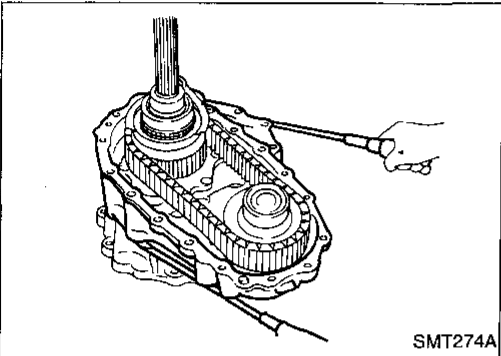

9. Remove bolts securing center case to front case, then separate center case from front case.

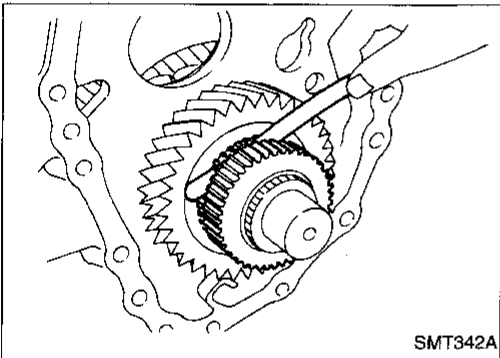

10. Measure low gear end play.

**Standard:**

0.2 - 0.35 mm (0.0079 - 0.0138 in)

- **If end play is not within specification, check low gear and L & H hub for wear.**

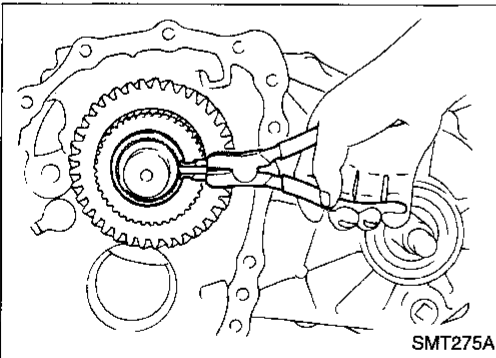

11. Disassemble center case assembly.
  - a. Remove snap ring from mainshaft.

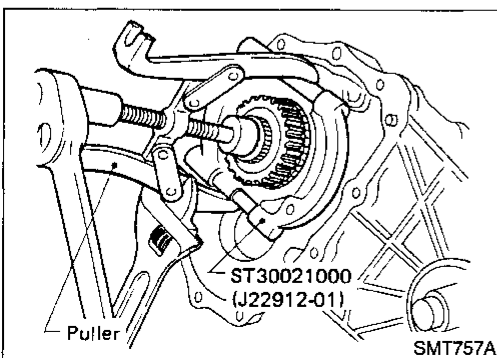

- b. Remove low gear with L & H hub.

# DISASSEMBLY

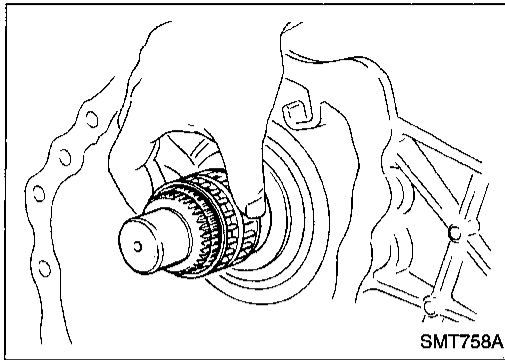

c. Remove needle bearing from main shaft.

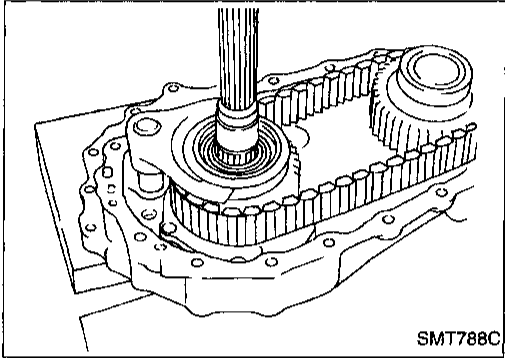

d. Make sure of the direction of the drive chain before removing it. (It must be reinstalled in the same direction.)

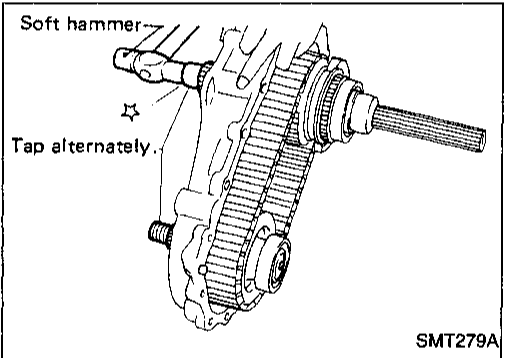

e. Remove mainshaft, front drive and drive chain as a set by tapping front end of mainshaft and front drive shaft alternately.  
 • **Be careful not to bend drive chain.**

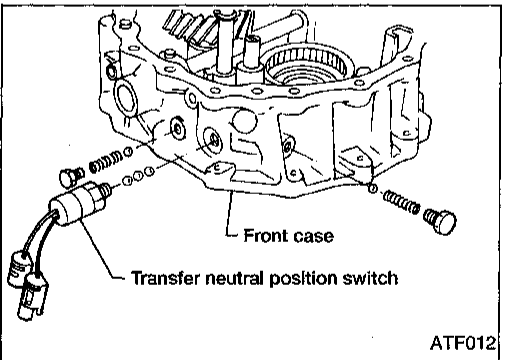

12. Disassemble front case assembly.

a. Remove transfer neutral position switch, plugs, check springs and check balls.

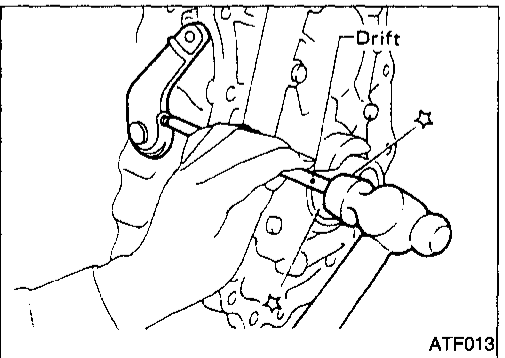

b. Remove lock pin from outer shift lever, then remove outer shift lever.

GI  
MA  
EM  
LC  
EC  
FE  
CL  
MT  
AT  
TF  
PD  
FA  
RA  
BR  
ST  
RS  
BT  
HA  
EL  
IDX

## DISASSEMBLY

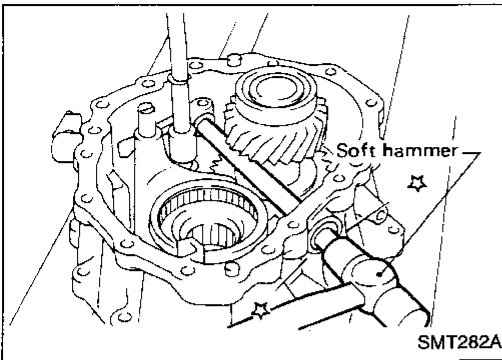

- c. Remove lock pin from inner shift lever, then drive out cross shaft and plug together.

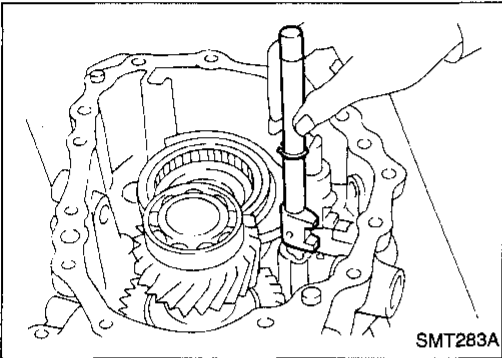

- d. Remove 2-4 shift rod.

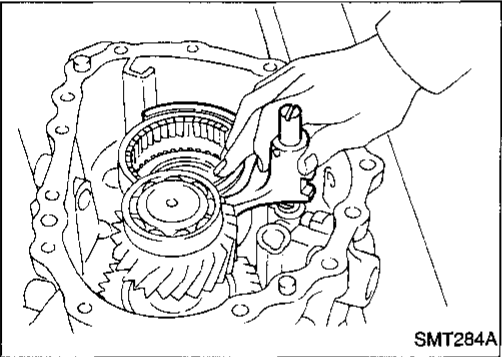

- e. Remove L & H shift rod and fork assembly with coupling sleeve.

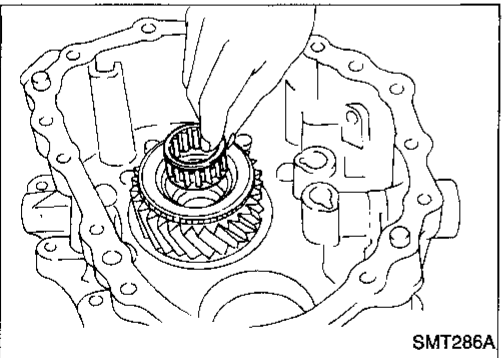

- f. Remove needle bearing from main gear.

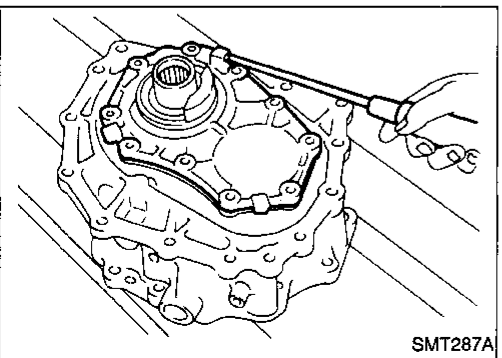

- g. Remove bolts securing front case cover, then remove case cover.



# DISASSEMBLY

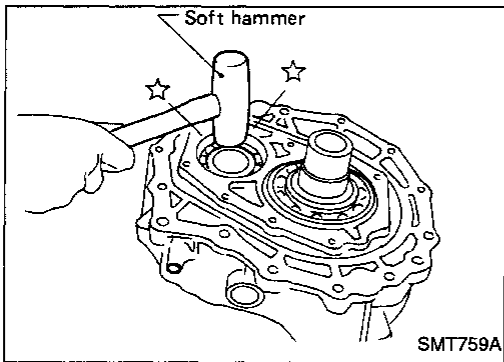

h. Remove counter gear by tapping lightly.

GI

MA

EM

LC

EC

FE

CL

MT

AT

**TF**

PD

FA

RA

BR

ST

RS

BT

HA

EL

IDX

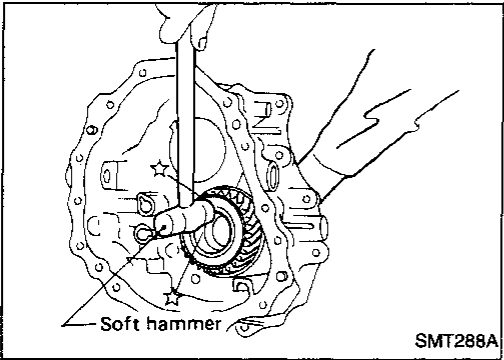

i. Remove main gear by tapping lightly.

# REPAIR FOR COMPONENT PARTS

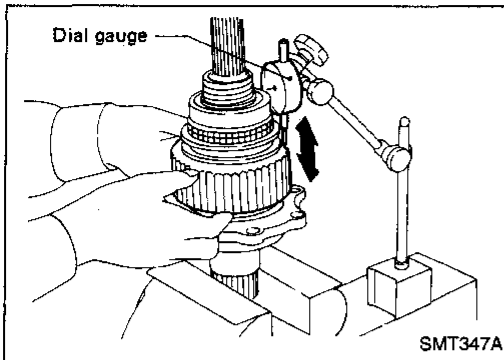

## Mainshaft

### DISASSEMBLY

1. Check front drive sprocket end play.

**Standard:**

**0.2 - 0.35 mm (0.0079 - 0.0138 in)**

- If end play is not within specification, check front drive sprocket and clutch gear for wear.

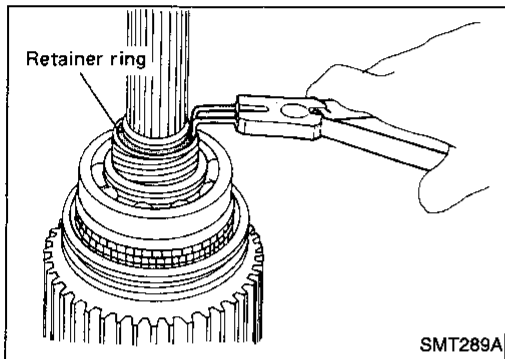

2. Remove retainer ring, speedometer drive gear and steel ball.
- Be careful not to lose the steel ball.

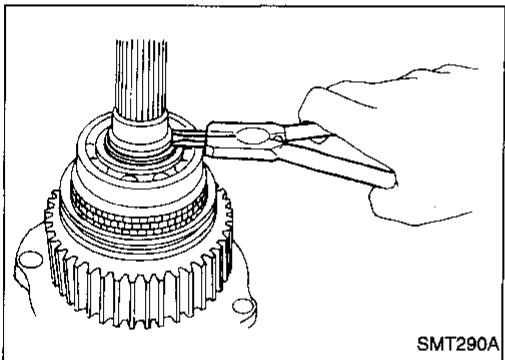

3. Remove snap ring and spacer.

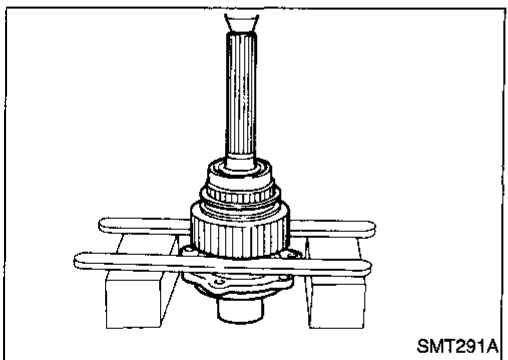

4. Use a press to remove front drive sprocket with mainshaft rear bearing and clutch gear together.
5. Remove needle bearing.

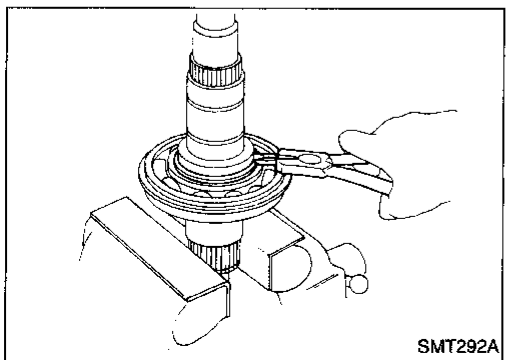

6. Remove bearing retainer, then remove snap ring.

# REPAIR FOR COMPONENT PARTS

## Mainshaft (Cont'd)

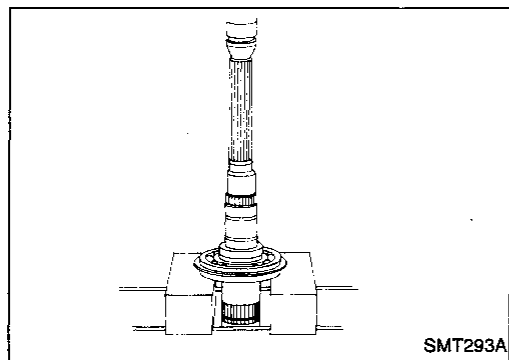

7. Use a press to remove mainshaft front bearing from mainshaft.

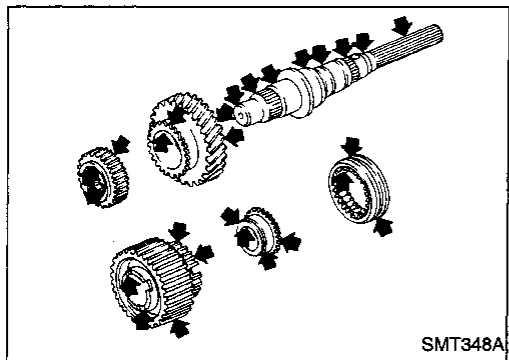

### INSPECTION

#### Gear and shaft

- Check gears for excessive wear, chips or cracks.
- Check shaft for cracks, wear or bending.
- Check coupling sleeve for wear or damage.

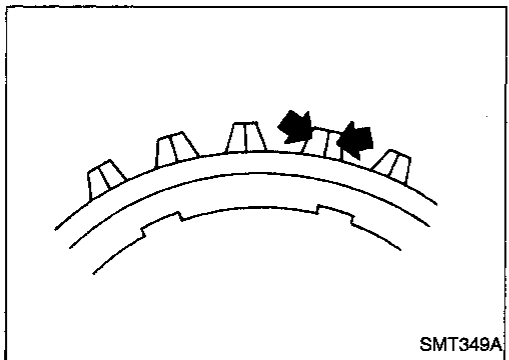

#### Baulk ring

- Check baulk ring for cracks or deformation.

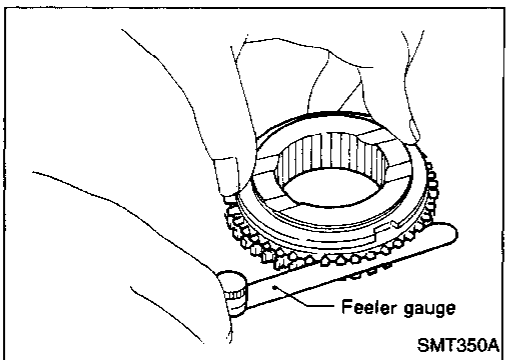

- Measure clearance between baulk ring and clutch gear.  
**Baulk ring to clutch gear clearance:**  
Refer to SDS, TF-33.

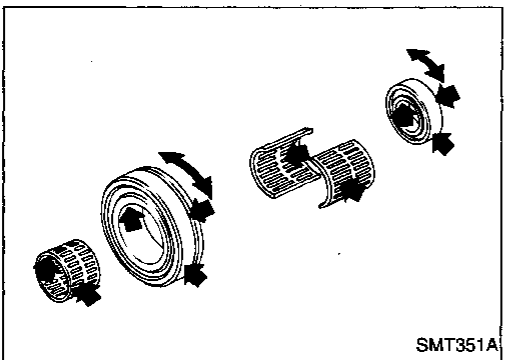

#### Bearing

- Make sure bearings roll freely and are free from noise, cracks, pitting or wear.

GI  
MA  
EM  
LC  
EC  
FE  
CL  
MT  
AT  
TF  
PD  
FA  
RA  
BR  
ST  
RS  
BT  
HA  
EL  
IDX

## REPAIR FOR COMPONENT PARTS

### Mainshaft (Cont'd)

#### ASSEMBLY

1. Press mainshaft front bearing onto mainshaft.
  - Pay attention to its direction.

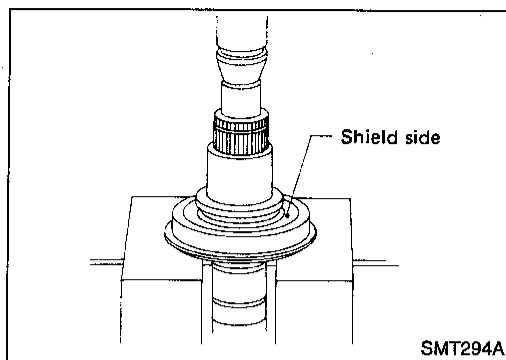

2. Select and install snap ring with proper thickness.  
**Allowable clearance between snap ring and groove:**  
0 - 0.15 mm (0 - 0.0059 in)  
**Available snap ring for mainshaft front bearing:**  
Refer to SDS, TF-33.
3. For further procedures, refer to "ASSEMBLY", TF-26.

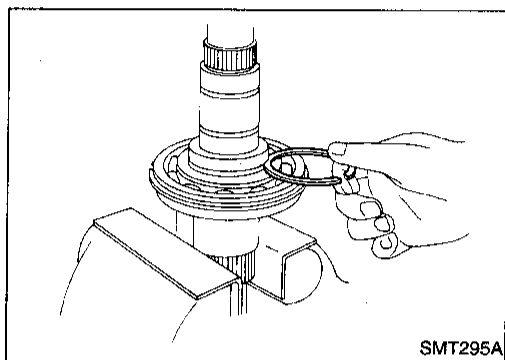

### Front Drive Shaft

#### DISASSEMBLY

- Using a gear puller, remove front drive shaft front and rear bearings.

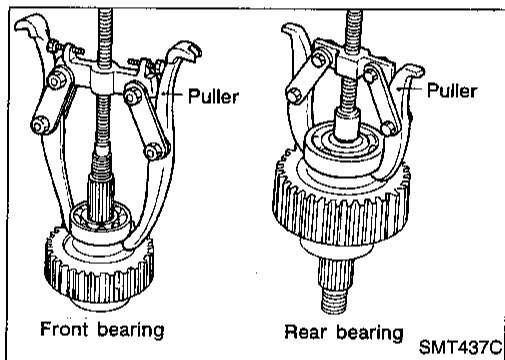

#### INSPECTION

##### Sprocket and shaft

- Check sprocket for excessive wear, chips or cracks.
- Check shaft for cracks or wear.

##### Bearing

- Make sure bearings roll freely and are free from noise, cracks, pitting or wear.

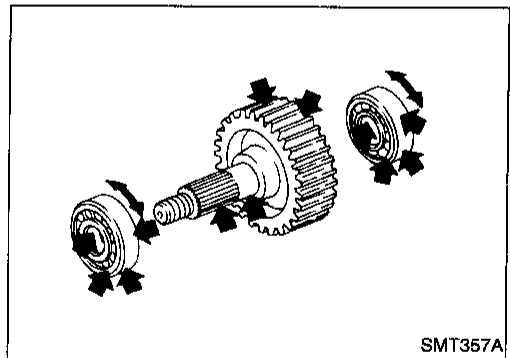

#### ASSEMBLY

- Press front drive shaft front and rear bearings onto front drive shaft.

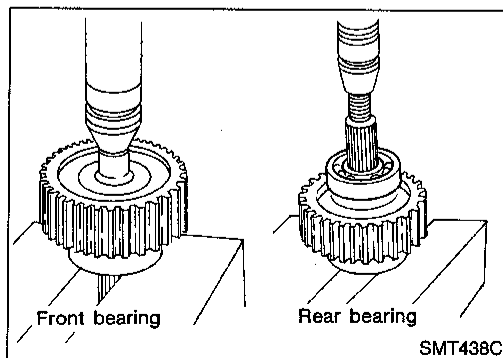

# REPAIR FOR COMPONENT PARTS

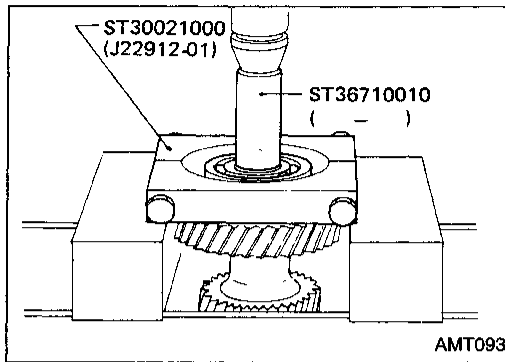

## Counter Gear

### DISASSEMBLY

1. Press out counter gear front bearing.
  - Remove front sub-gear, dish plate and spacer.

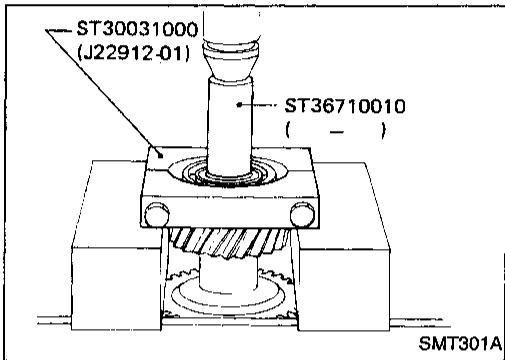

2. Press out counter gear rear bearing.
  - Remove rear sub-gear, dish plate and spacer.

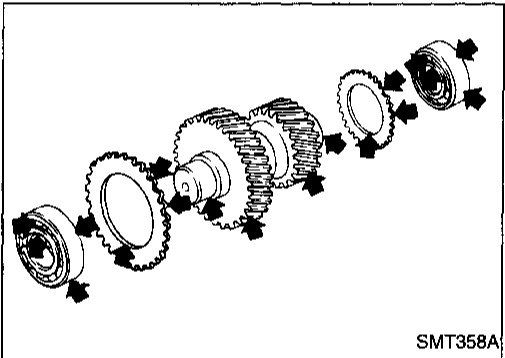

### INSPECTION

#### Gear and shaft

- Check gears for excessive wear, chips or cracks.
- Check shaft for cracks or wear.

#### Bearing

- Make sure bearings roll freely and are free from noise, cracks, pitting or wear.

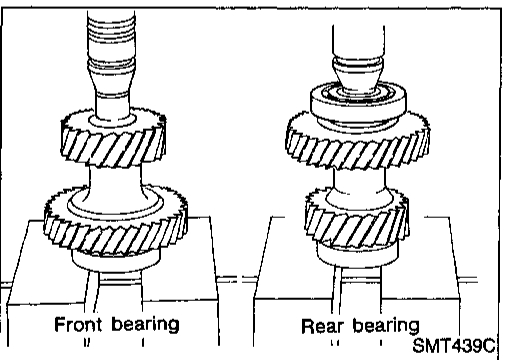

### ASSEMBLY

1. Install front sub-gear, dish plate and spacer.
2. Press on counter gear front bearing.
3. Install rear sub-gear, dish plate and spacer.
4. Press on counter gear rear bearing.

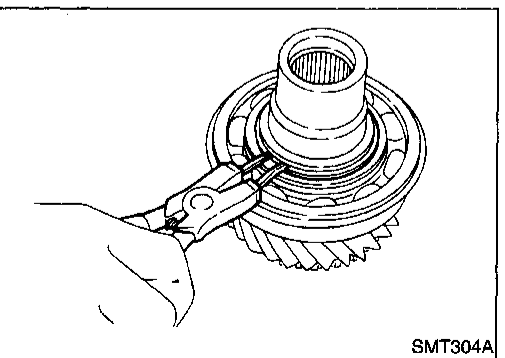

## Main Gear

### DISASSEMBLY

#### Main gear bearing

1. Remove snap ring.

GI  
MA  
EM  
LC  
EC  
FE  
CL  
MT  
AT  
TF  
PD  
FA  
RA  
BR  
ST  
RS  
BT  
HA  
EL  
IDX

## REPAIR FOR COMPONENT PARTS

### Main Gear (Cont'd)

2. Pull out main gear bearing.

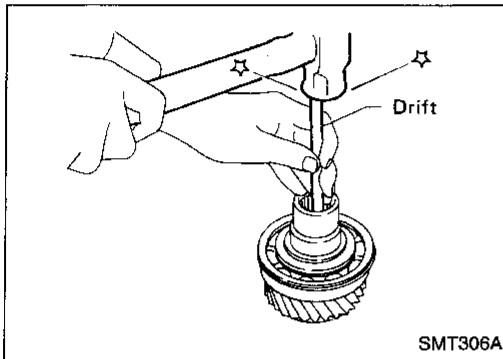
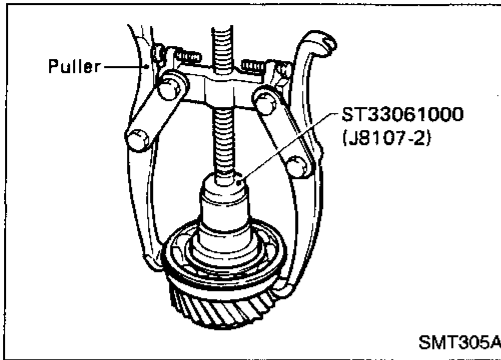

### Plug

- Always replace with a new one whenever it has been removed.

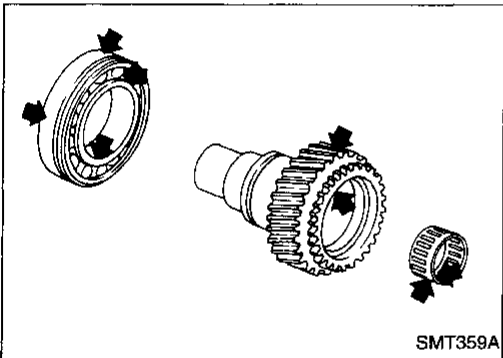

### INSPECTION

#### Gear and shaft

- Check gears for excessive wear, chips or cracks.
- Check shaft for cracks or wear.

#### Bearing

- Make sure bearings roll freely and are free from noise, cracks, pitting or wear.

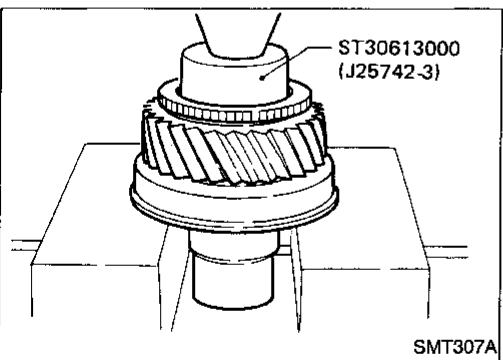

### ASSEMBLY

#### Main gear bearing

1. Press on main gear bearing.

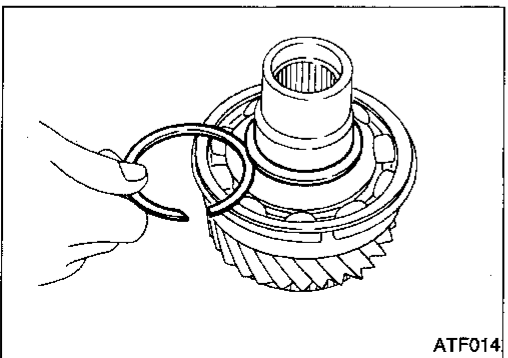

2. Select and install snap ring with proper thickness.  
**Allowable clearance between snap ring and groove:**  
0 - 0.15 mm (0 - 0.0059 in)  
**Available snap ring for main gear bearing:**  
Refer to SDS, TF-33.

# REPAIR FOR COMPONENT PARTS

## Main Gear (Cont'd)

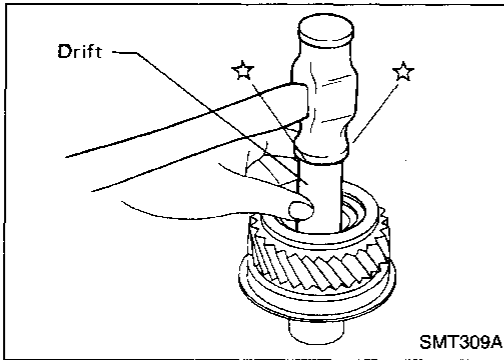

### Plug

Apply sealant to plug, then install.

- Use genuine anaerobic liquid gasket, Three Bond TB1215, Loctite Part No. 51813 or equivalent.

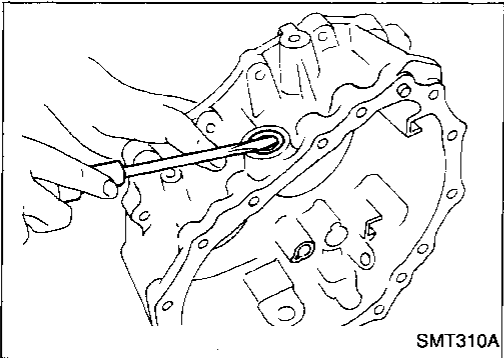

## Front Case

### SHIFT SHAFT OIL SEAL

#### Removal

- Use a screwdriver to pry out old seal.
- Be careful not to damage case.
- Always replace with a new one whenever it has been removed.

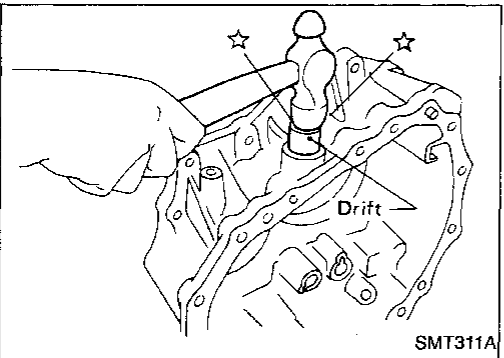

#### Installation

- Install new shift shaft oil seal until flush with case.
- Before installing, apply multi-purpose grease to seal lip.

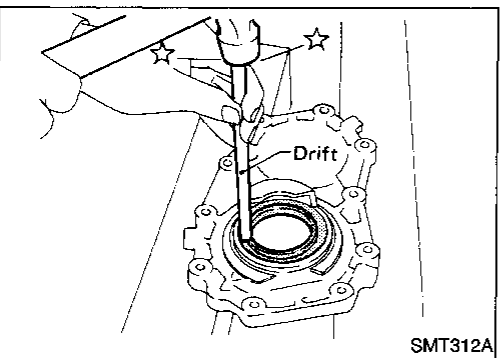

## Front Case Cover

### COVER OIL SEAL

#### Removal

- Drive out old seal from inside of front case cover.
- Be careful not to damage front case cover.

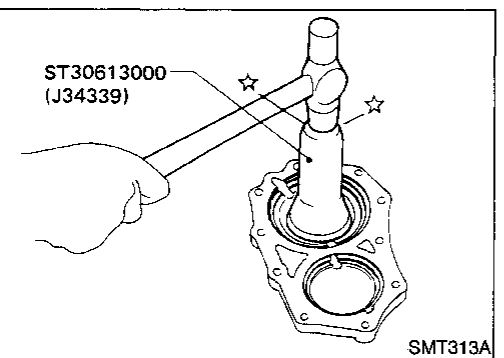

#### Installation

- Install new front case cover oil seal until it stops.
- Before installing, apply multi-purpose grease to seal lip.

GI

MA

EM

LC

EC

FE

CL

MT

AT

TF

PD

FA

RA

BR

ST

RS

BT

HA

EL

IDX

## REPAIR FOR COMPONENT PARTS

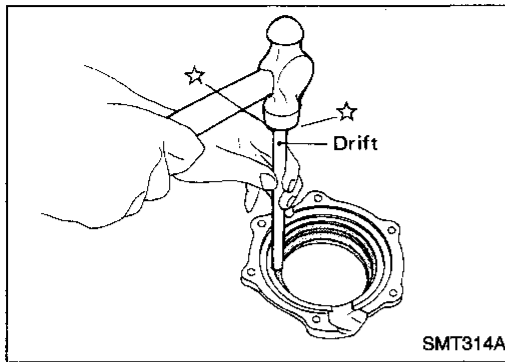

### Bearing Retainer

#### OIL CATCHER

##### Removal

- Drive out oil catcher from inside of bearing retainer.
- Be careful not to damage bearing retainer.

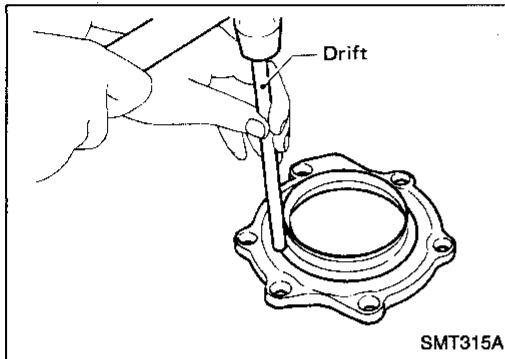

##### Installation

- Install oil catcher until it stops.
- Be careful not to damage or distort oil catcher or bearing retainer.
- Before installing, apply multi-purpose grease to seal lip.

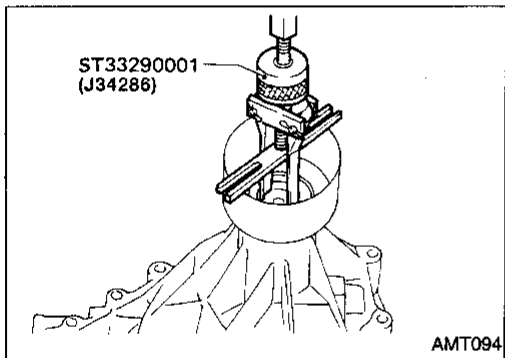

### Rear Case

#### REAR OIL SEAL

##### Removal

- Pull out rear oil seal.

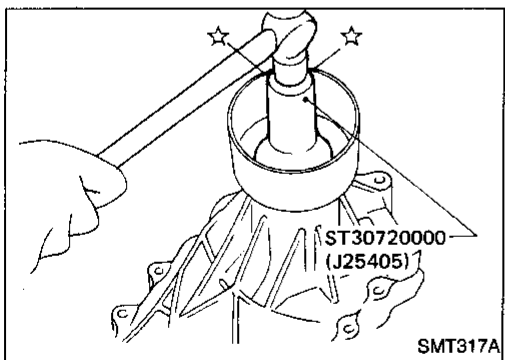

##### Installation

- Install new rear oil seal until it stops.
- Before installing, apply multi-purpose grease to seal lip.

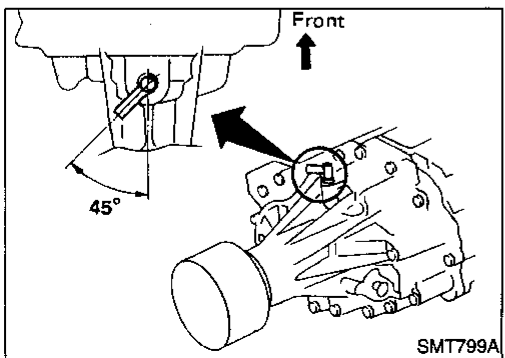

### AIR BREATHER

Install as shown in illustration.

- Use genuine thread locker, Three Bond TB1324, Loctite 271 or equivalent.



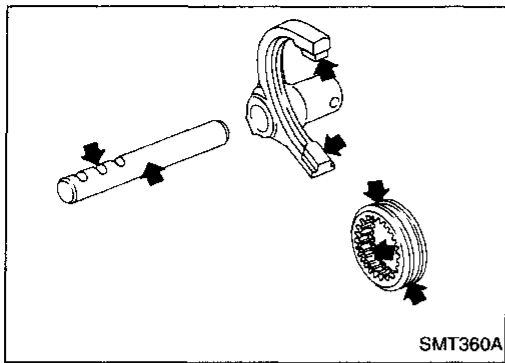

## Shift Control Components

### INSPECTION

- Check contact surface and sliding surface for wear, scratches, projections or other faulty conditions.

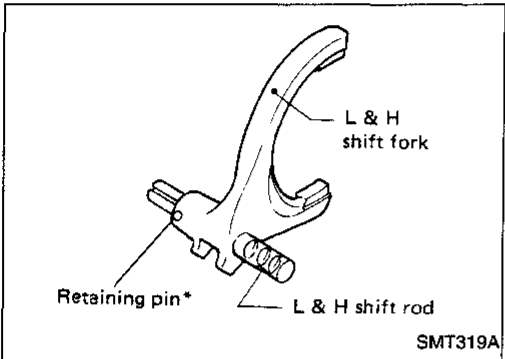

### L & H SHIFT ROD & FORK

- Assemble as shown in illustration.

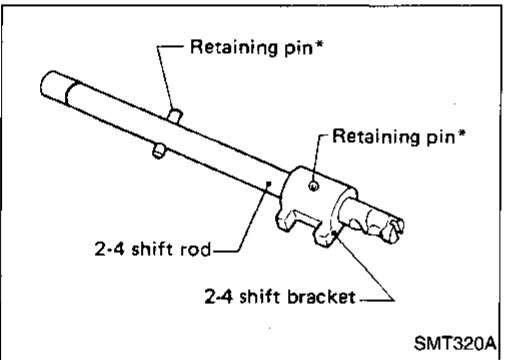

### 2-4 SHIFT ROD & FORK

- Assemble as shown in illustration.

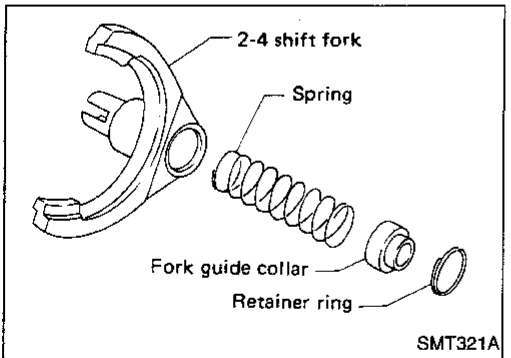

- Pay special attention to the direction of fork guide collar.

GI

MA

EM

LC

EC

FE

CL

MT

AT

TF

PD

FA

RA

BR

ST

RS

BT

HA

EL

IDX

## ASSEMBLY

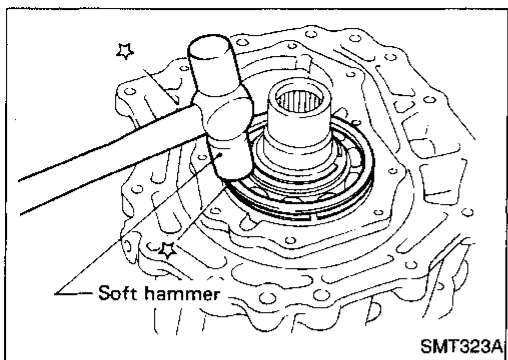

1. Assemble front case.
  - a. Install main gear assembly by tapping lightly.

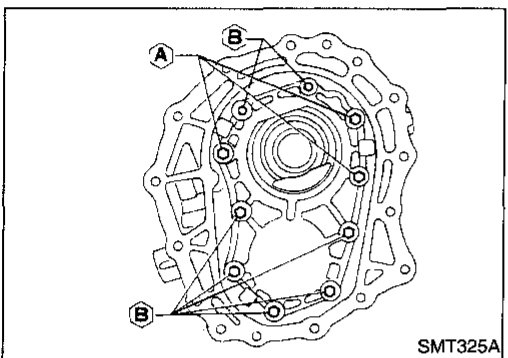

- b. Apply sealant to the mating surface and bolts of front case cover, then attach it to the front case.
      - Use genuine anaerobic liquid gasket, Three Bond TB1215, Loctite Part No. 51813 or equivalent.
      - These ten bolts should be coated with sealant.
        - Bolts A:**  
☑: 16 - 21 N·m (1.6 - 2.1 kg·m, 12 - 15 ft·lb)
        - Bolts B:**  
☑: 19 - 24 N·m (1.9 - 2.4 kg·m, 14 - 17 ft·lb)

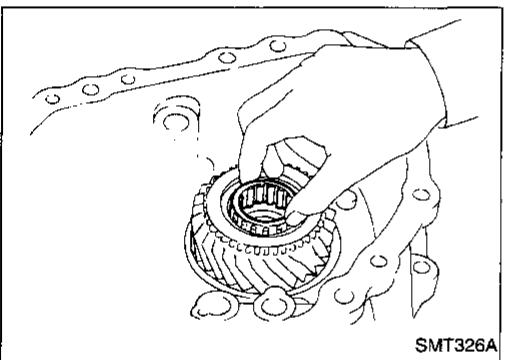

- c. Apply ATF to needle bearing and install it into main gear.

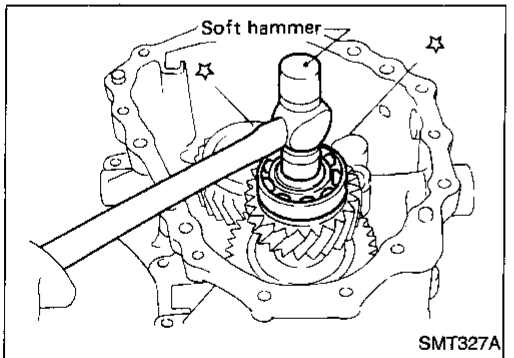

- d. Install counter gear assembly by tapping lightly.

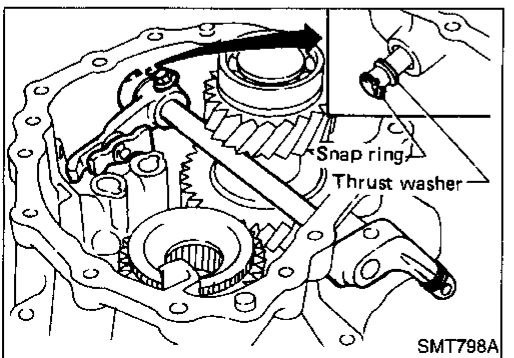

- e. Install cross shaft and inner shift lever.
          - When replacing cross shaft, outer shift lever or outer shift lever lock pin, replace them as a set.

# ASSEMBLY

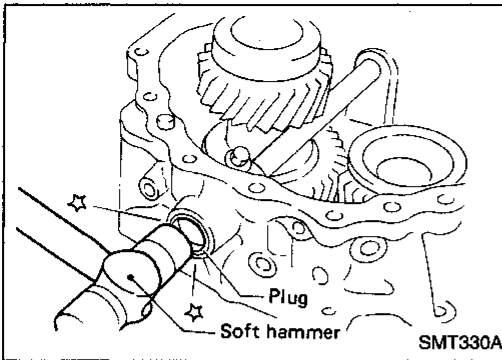

- f. Apply sealant to plug, then install it into front case.
- Use genuine anaerobic liquid gasket, Three Bond TB1215, Loctite Part No. 51813 or equivalent.

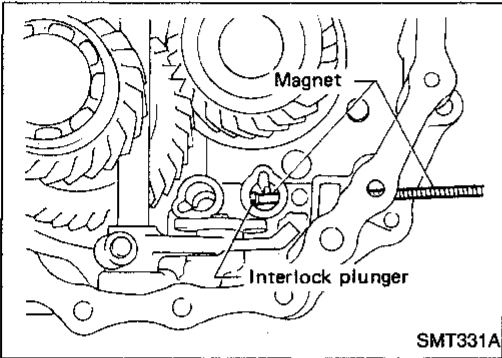

- g. Insert interlock plunger into front case.

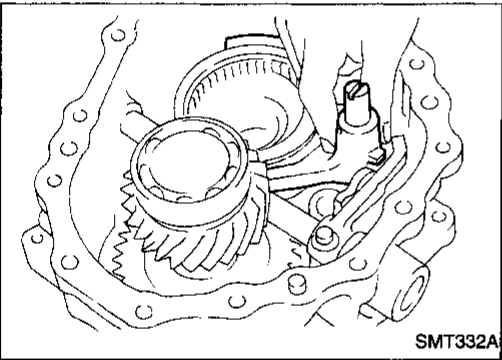

- h. Install L & H shift rod and fork assembly with coupling sleeve.

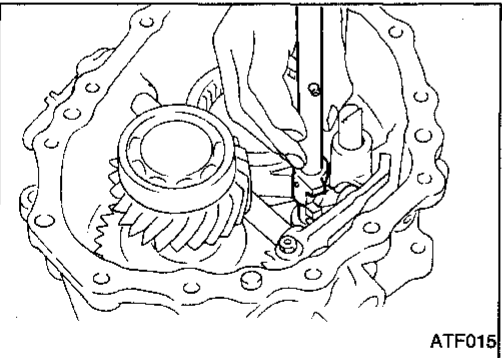

- i. Install 2-4 shift rod.

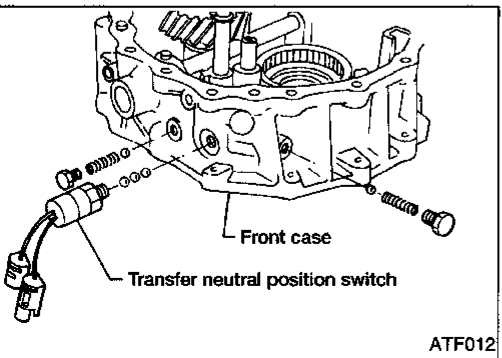

- j. Install transfer neutral position switch, check balls, check springs and plugs.
- Apply sealant to switch and plugs.
  - Use genuine anaerobic liquid gasket, Three Bond TB1215, Loctite Part No. 51813 or equivalent.

GI  
MA  
EM  
LC  
EC  
FE  
CL  
MT  
AT  
TF  
PD  
FA  
RA  
BR  
ST  
RS  
BT  
HA  
EL  
IDX

# ASSEMBLY

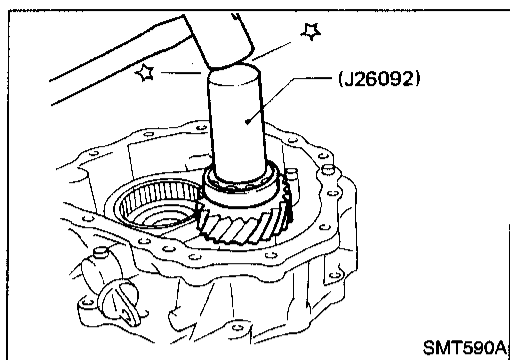

2. Select counter gear rear bearing shim.
  - a. Seat counter gear assembly.

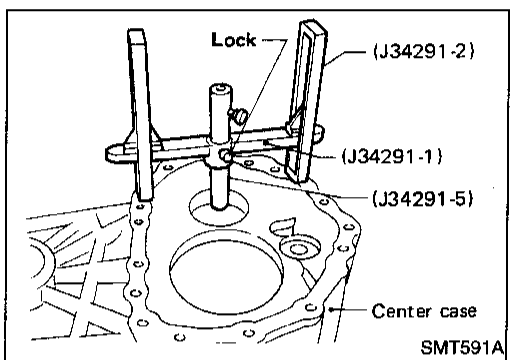

- b. Place J34291-1 (bridge), J34291-2 (legs) and J34291-5 (gauging cylinder) on machined surface of center case, allowing gauging cylinder to rest on top outer portion of counter gear rear bearing. Lock gauging cylinder in place.

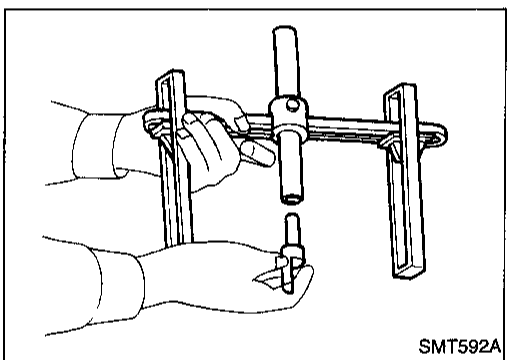

- c. Insert J34291-20 (gauging plunger) into J34291-5 (gauging cylinder).

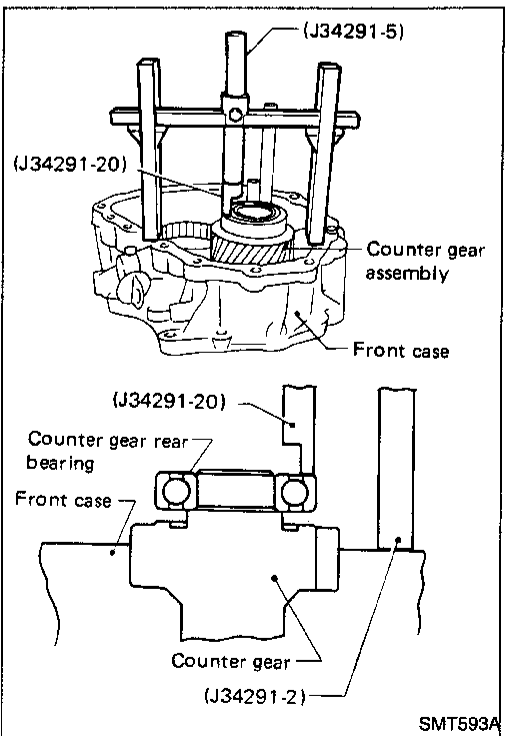

- d. Place bridge, legs, gauging cylinder and gauging plunger onto machined surface of front case assembly, allowing gauging plunger to drop until it contacts counter gear rear bearing mating surface.

# ASSEMBLY

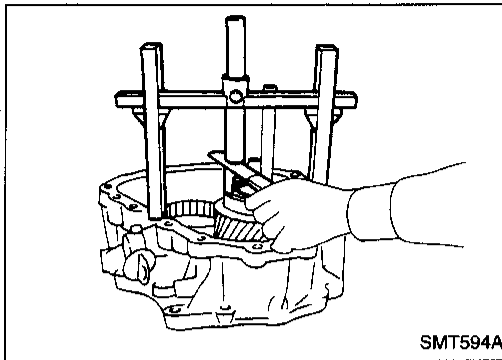

- e. Lock gauging plunger in place and use feeler gauge to measure end play between gauging cylinder and gauging plunger.
- f. Use measured distance to select correct counter gear rear bearing shim.

**Allowable counter gear end play:**  
0 - 0.2 mm (0 - 0.008 in)

**Available counter gear rear bearing shim:**  
Refer to SDS, TF-33.

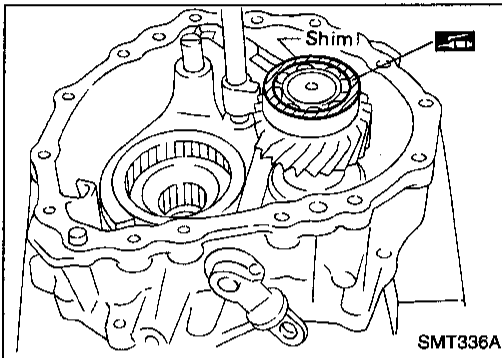

- 3. Place suitable shim with grease on counter gear rear bearing.
- 4. Apply ATF to each part in front case.

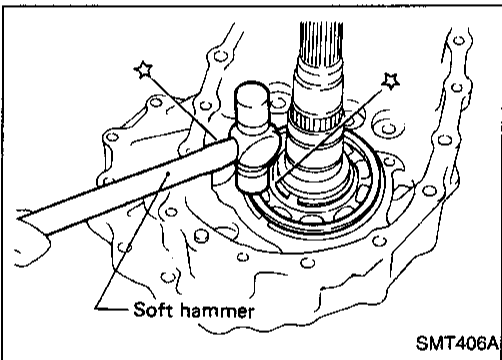

- 5. Assemble center case assembly.
  - a. Install mainshaft on center case by tapping lightly.
- **Apply ATF to mainshaft front bearing.**

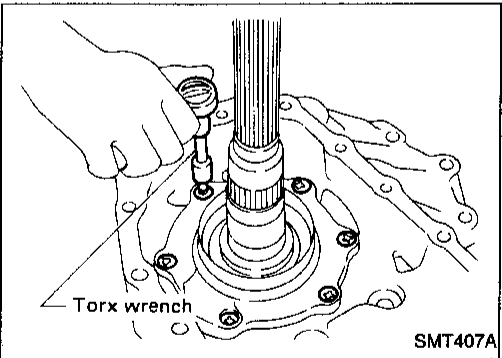

- b. Install bearing retainer.  
Ⓜ: 16 - 21 N·m (1.6 - 21 kg-m, 12 - 15 ft-lb)

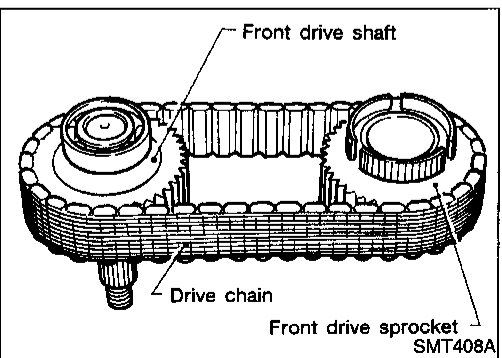

- c. Put drive chain onto the front drive sprocket and front drive shaft, and then put them in center case.
- **Be sure to install drive chain in same direction as removed.**

GI  
MA  
EM  
LC  
EC  
FE  
CL  
MT  
AT  
TF  
PD  
FA  
RA  
BR  
ST  
RS  
BT  
HA  
EL  
IDX  
805

# ASSEMBLY

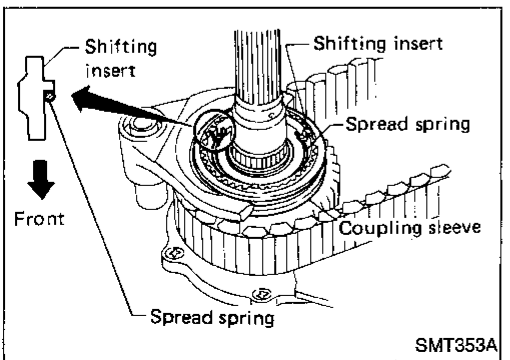
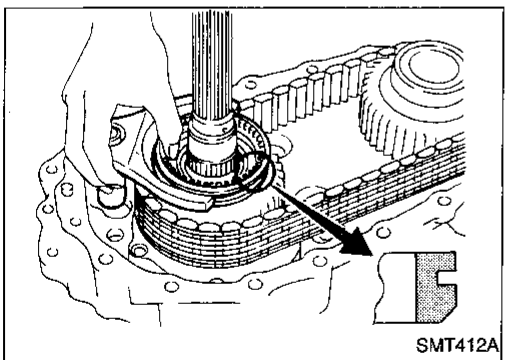
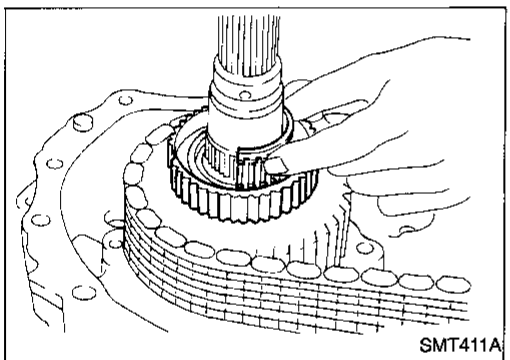
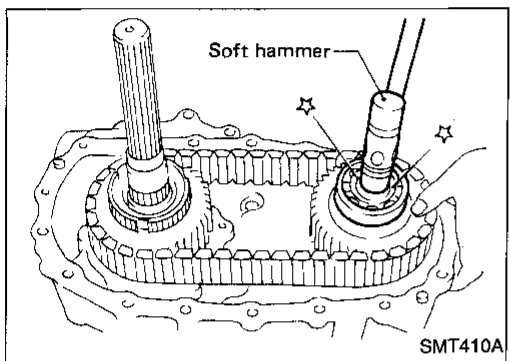
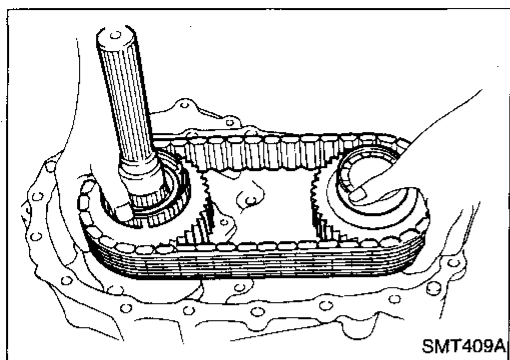

- d. Install front drive shaft by tapping lightly.
- **Make sure shafts are aligned in the case.**

- e. Apply ATF to needle bearings and install them into front drive sprocket.
- **These needle bearings will be installed more easily if front drive sprocket is rotated while installing them.**

- f. Install 2-4 coupling sleeve with 2-4 shift fork.
- **Pay attention to the direction of the coupling sleeve.**

- g. Install shifting inserts and spread spring.
- **Pay attention to the direction of shifting inserts.**

# ASSEMBLY

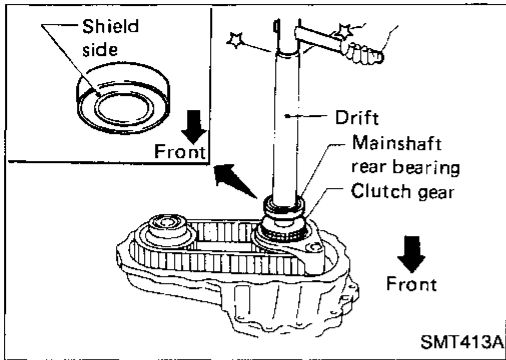

- h. Install baulk ring, then install clutch gear and mainshaft rear bearing.
- **Place wooden block under mainshaft in order to protect mainshaft front bearing.**

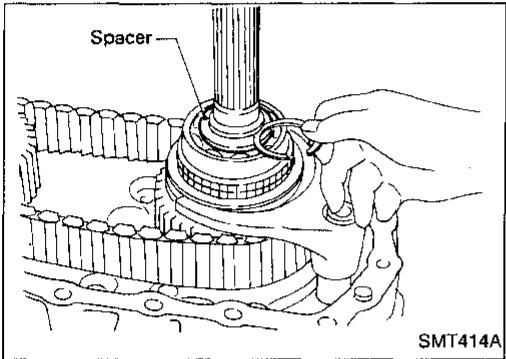

- i. Install spacer.
- j. Select and install snap ring with proper thickness.
- Allowable clearance between snap ring and groove:  
0 - 0.15 mm (0 - 0.0059 in)**
- Available snap ring for mainshaft rear bearing:  
Refer to SDS, TF-33.**

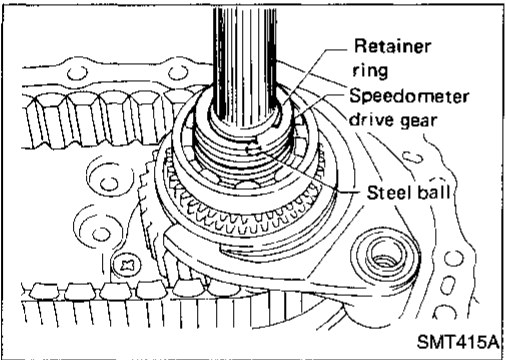

- k. Install steel ball, speedometer drive gear and retainer ring.
- **Steel ball is the smallest check ball for this unit.**

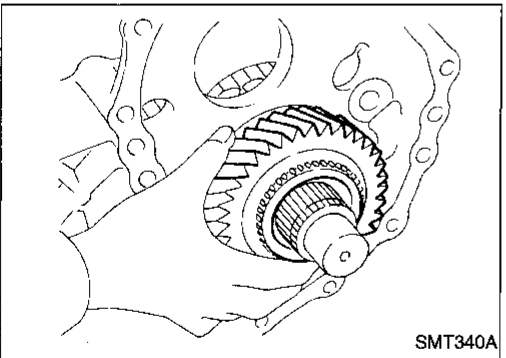

- l. Install low gear and bearing onto mainshaft.
- **Apply ATF to needle bearing.**

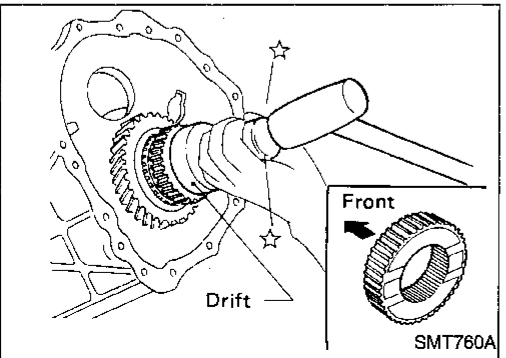

- m. Install L & H hub and snap ring onto mainshaft.
- **Pay attention to the direction of L & H hub.**

## ASSEMBLY

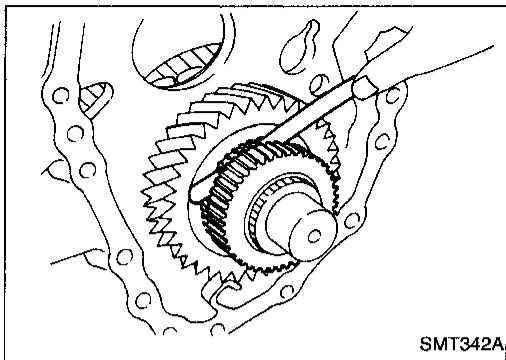

- n. Measure low gear end play.
- **Standard: 0.2 - 0.35 mm (0.0079 - 0.0138 in)**

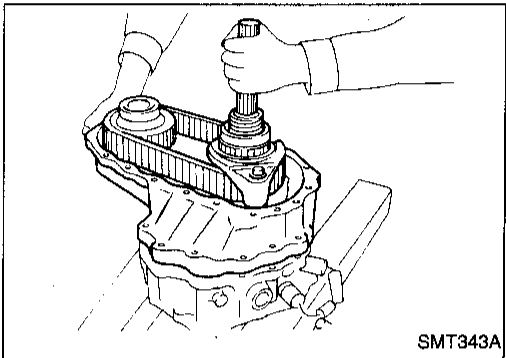

6. Apply sealant to mating surface of center case, then attach to front case and tighten bolts.
- **Use genuine anaerobic liquid gasket, Three Bond TB1215, Loctite Part No. 51813 or equivalent.**

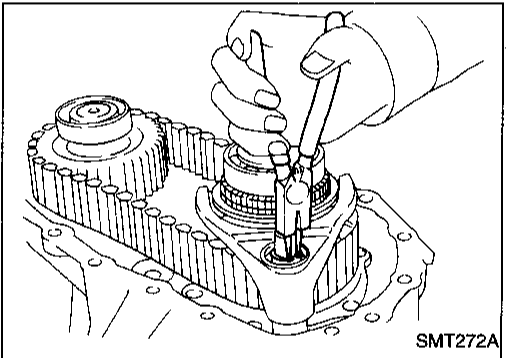

7. Install snap ring to 2-4 shift rod.

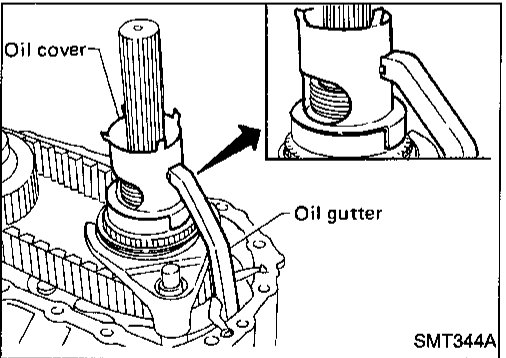

8. Install oil gutter and oil cover.
9. Apply ATF to each part in center case.

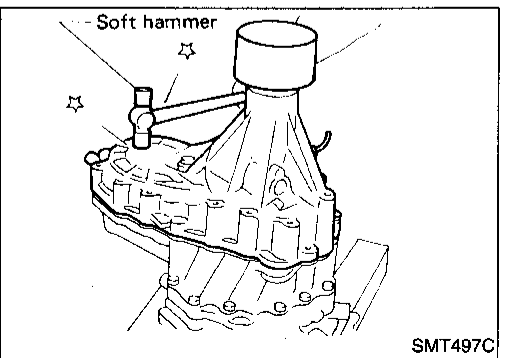

10. Apply sealant to mating surface of rear case, then attach it to center case and tighten bolts.
- **Use genuine anaerobic liquid gasket, Three Bond TB1215, Loctite Part No. 51813 or equivalent.**
11. Install 4WD switch and vehicle speed sensor.
- **Apply sealant to switch threads.**
  - **Use genuine anaerobic liquid gasket, Three Bond TB1215, Loctite Part No. 51813 or equivalent.**



# SERVICE DATA AND SPECIFICATIONS (SDS)

## General Specifications

Transfer model		TX10A	
Gear ratio	High	1.000	
	Low	2.020	
Number of teeth	Main gear	29	
	Low gear	37	
	Counter gear	High	38
		Low	24
	Front drive sprocket	41	
Front drive shaft	41		
Fluid capacity	ℓ (US qt, Imp qt)	2.2 (2-3/8, 2)	

## Inspection and Adjustment

### CLEARANCE BETWEEN FRONT DRIVE SPROCKET AND 2-4 COUPLING SLEEVE

Unit: mm (in)

Allowable clearance "C"	0.2 - 0.54 (0.008 - 0.0213)
-------------------------	-----------------------------

### GEAR END PLAY

Unit: mm (in)

Front drive sprocket	0.2 - 0.35 (0.0079 - 0.0138)
Low gear	0.2 - 0.35 (0.0079 - 0.0138)
Counter gear	0 - 0.2 (0 - 0.008)

### CLEARANCE BETWEEN BAULK RING AND CLUTCH GEAR

Unit: mm (in)

Standard	Wear limit
1.0 - 1.5 (0.039 - 0.059)	0.5 (0.020)

### AVAILABLE SHIM

#### Counter gear rear bearing

Unit: mm (in)

Allowable clearance		0 - 0.2 (0 - 0.008)	
Thickness	Part number	Thickness	Part number
0.1 (0.004)	33112-C6900	0.2 (0.008)	33112-C6901
0.2 (0.008)	33112-C6901	0.3 (0.012)	33112-C6902
0.3 (0.012)	33112-C6902	0.4 (0.016)	33112-C6903
0.4 (0.016)	33112-C6903	0.5 (0.020)	33112-33G00
0.5 (0.020)	33112-33G00	0.6 (0.024)	33112-33G01
0.6 (0.024)	33112-33G01		

### AVAILABLE SNAP RING

#### Mainshaft front bearing

Unit: mm (in)

Allowable clearance		0 - 0.15 (0 - 0.0059)	
Thickness	Part number	Thickness	Part number
3.1 (0.122)	33138-73P10	3.19 (0.126)	33138-73P11
3.19 (0.126)	33138-73P11	3.28 (0.129)	33138-73P12
3.28 (0.129)	33138-73P12		

#### Main gear bearing

Unit: mm (in)

Allowable clearance		0 - 0.15 (0 - 0.0059)	
Thickness	Part number	Thickness	Part number
2.60 (0.102)	33114-73P00	2.69 (0.106)	33114-73P01
2.69 (0.106)	33114-73P01	2.78 (0.109)	33114-73P02
2.78 (0.109)	33114-73P02		

#### Mainshaft rear bearing

Unit: mm (in)

Allowable clearance		0 - 0.15 (0 - 0.0059)	
Thickness	Part number	Thickness	Part number
1.8 (0.071)	33138-73P20	1.89 (0.074)	33138-73P21
1.89 (0.074)	33138-73P21	1.98 (0.078)	33138-73P22
1.98 (0.078)	33138-73P22	2.07 (0.081)	33138-73P23
2.07 (0.081)	33138-73P23	2.16 (0.085)	33138-73P24
2.16 (0.085)	33138-73P24		