

MANUAL TRANSMISSION

SECTION MT

CONTENTS

	FS5W71C	
PREPARATION	3	
Special Service Tools	3	
Commercial Service Tools	5	
NOISE, VIBRATION AND HARSHNESS (NVH)		
TROUBLESHOOTING	6	
NVH Troubleshooting Chart.....	6	
MANUAL TRANSMISSION.....	6	
DESCRIPTION	7	
Cross-sectional View	7	
ON-VEHICLE SERVICE	8	
Replacing Rear Oil Seal.....	8	
REMOVAL.....	8	
INSTALLATION.....	8	
Position Switch Check.....	8	
REMOVAL AND INSTALLATION	9	
Removal.....	9	
Installation.....	10	
OVERHAUL	11	
Case Components.....	11	
Gear Components	12	
Shift Control Components	13	
DISASSEMBLY	14	
Case Components.....	14	
DISASSEMBLY.....	14	
Shift Control Components	14	
DISASSEMBLY.....	14	
Gear Components	15	
DISASSEMBLY.....	15	
INSPECTION	18	
Shift Control Components	18	
INSPECTION.....	18	
Gear Components	18	
INSPECTION.....	18	
ASSEMBLY	20	
Gear Components	20	
ASSEMBLY	20	
Shift Control Components	26	
ASSEMBLY	26	

Case Components	27	
ASSEMBLY	27	
SERVICE DATA AND SPECIFICATIONS (SDS)	30	
General Specifications.....	30	
Gear End Play	30	
Clearance Between Baulk Ring and Gear	31	
Available Snap Rings	31	
MAIN DRIVE GEAR BEARING.....	31	
MAINSHAFT FRONT.....	31	
COUNTER DRIVE GEAR	31	
OD MAINSHAFT BEARING	32	
Available Shims	32	
COUNTERSHAFT FRONT BEARING	32	

	FS5R30A	
PREPARATION	33	
Special Service Tools	33	
Commercial Service Tool.....	35	
NOISE, VIBRATION AND HARSHNESS (NVH)		
TROUBLESHOOTING	36	
NVH Troubleshooting Chart.....	36	
MANUAL TRANSMISSION.....	36	
DESCRIPTION	37	
Cross-sectional View - 2WD Model.....	37	
Cross-sectional View - 4WD Model.....	38	
ON-VEHICLE SERVICE	39	
Replacing Rear Oil Seal - 2WD Model	39	
REMOVAL.....	39	
INSTALLATION.....	39	
Position Switch Check.....	40	
REMOVAL AND INSTALLATION	41	
Removal.....	41	
2WD MODEL.....	41	
4WD MODEL.....	42	
Installation.....	43	
OVERHAUL	44	
Case Components	44	
Gear Components	45	
Shift Control Components (2/4WD models)	47	

GI
MA
EM
LC
EC
FE
CL
MT
AT
TF
PD
AX
SU
BR
ST
RS
BT
HA
SC
EL
IDX

CONTENTS (Cont'd)

DISASSEMBLY	48	ASSEMBLY.....	65
Case Components.....	48	SERVICE DATA AND SPECIFICATIONS (SDS)	67
DISASSEMBLY.....	48	General Specifications.....	67
Shift Control Components.....	49	Gear End Play.....	67
DISASSEMBLY.....	49	Clearance Between Single Baulk Ring and Gear.....	67
Gear Components.....	50	DOUBLE BAULK RING.....	68
DISASSEMBLY.....	50	Distance Between Rear Surface of Reverse	
INSPECTION	54	Cone and Reverse Baulk Ring.....	68
Shift Control Components.....	54	Available Snap Ring.....	68
INSPECTION.....	54	MAIN DRIVE GEAR SNAP RING.....	68
Gear Components.....	54	MAINSHAFT FRONT SNAP RING.....	68
INSPECTION.....	54	COUNTER GEAR REAR SNAP RING.....	69
ASSEMBLY	56	Available C-ring.....	69
Gear Components.....	56	MAINSHAFT C-RING.....	69
ASSEMBLY.....	56	Available Shim and Washer.....	69
Shift Control Components.....	64	TABLE FOR SELECTING PROPER COUNTER	
ASSEMBLY.....	64	GEAR FRONT BEARING THRUST WASHER.....	69
Case Components.....	65	REVERSE IDLER REAR THRUST WASHER.....	70

Special Service Tools

NEMT0050

The actual shapes of Kent-Moore tools may differ from those of special service tools illustrated here.

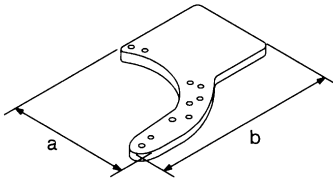
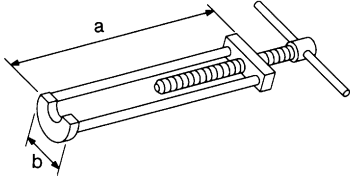
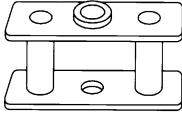
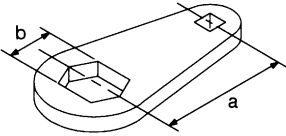
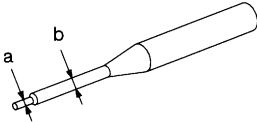
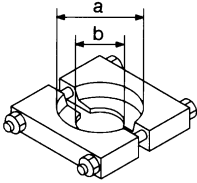
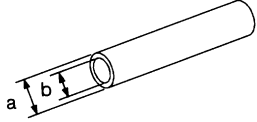
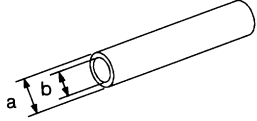
Tool number (Kent-Moore No.) Tool name	Description	
ST23810001 (—) Adapter setting plate		Fixing adapter plate with gear assembly a: 166 mm (6.54 in) b: 270 mm (10.63 in)
	NT407	
KV32101330 (See J34286) Puller		Removing overdrive mainshaft bearing a: 447 mm (17.60 in) b: 100 mm (3.94 in)
	NT408	
KV31100401 (—) Transmission press stand		Pressing counter gear and mainshaft
	NT068	
ST22520000 (J26348) Wrench		Tightening mainshaft lock nut a: 100 mm (3.94 in) b: 41 mm (1.61 in)
	NT409	
ST23540000 (J25689-A) Pin punch		Removing and installing fork rod retaining pin a: 2.3 mm (0.091 in) dia. b: 4 mm (0.16 in) dia.
	NT442	
ST30031000 (J22912-01) Puller		Removing and installing 1st gear bushing Removing main drive gear bearing a: 90 mm (3.54 in) dia. b: 50 mm (1.97 in) dia.
	NT411	
ST23860000 (—) Drift		Installing counter drive gear a: 38 mm (1.50 in) dia. b: 33 mm (1.30 in) dia.
	NT065	
ST22360002 (J25679-01) Drift		Installing counter gear front and rear end bearings a: 29 mm (1.14 in) dia. b: 23 mm (0.91 in) dia.
	NT065	

GI

MA

EM

LC

EC

FE

CL

MT

AT

TF

PD

AX

SU

BR

ST

RS

BT

HA

SC

EL

IDX

PREPARATION

FS5W71C

Special Service Tools (Cont'd)

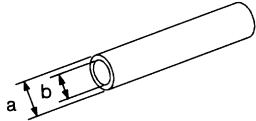
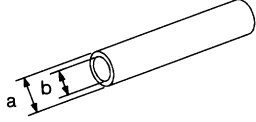
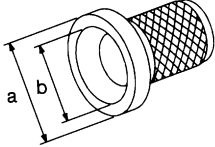
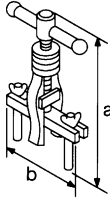
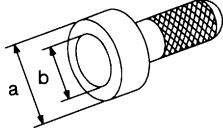
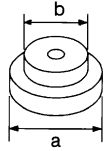
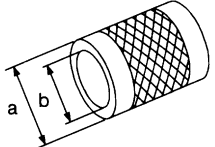
Tool number (Kent-Moore No.) Tool name	Description	
ST22350000 (J25678-01) Drift		Installing OD gear bushing a: 34 mm (1.34 in) dia. b: 28 mm (1.10 in) dia.
NT065		
ST23800000 (J25691-01) Drift		Installing front cover oil seal a: 44 mm (1.73 in) dia. b: 31 mm (1.22 in) dia.
NT065		
ST33400001 (J26082) Drift		Installing rear oil seal a: 60 mm (2.36 in) dia. b: 47 mm (1.85 in) dia.
NT086		
ST33290001 (J34286) Puller		Removing rear oil seal a: 250 mm (9.84 in) b: 160 mm (6.30 in)
NT414		
ST30720000 (J25405) Drift		Installing mainshaft ball bearing a: 77 mm (3.03 in) dia. b: 55.5 mm (2.185 in) dia.
NT115		
ST30613000 (J25742-3) Drift		Installing main drive gear bearing a: 71.5 mm (2.815 in) dia. b: 47.5 mm (1.870 in) dia.
NT073		
ST33200000 (J26082) Drift		Installing counter rear bearing a: 60 mm (2.36 in) dia. b: 44.5 mm (1.752 in) dia.
NT091		

PREPARATION

FS5W71C

Commercial Service Tools

Commercial Service Tools

NEMT0051

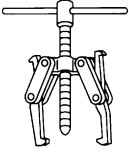
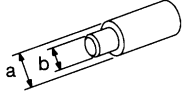
Tool name	Description	GI
Puller	 <p>Removing counter bearings, counter drive and OD gears</p> <p>NT077</p>	<p>MA</p> <p>EM</p>
Drift	 <p>Installing countershaft rear end bearing a: 40 mm (1.57 in) dia. b: 30 mm (1.18 in) dia.</p> <p>NT074</p>	<p>LC</p> <p>EC</p>

FE

CL

MT

AT

TF

PD

AX

SU

BR

ST

RS

BT

HA

SC

EL

IDX

NOISE, VIBRATION AND HARSHNESS (NVH) TROUBLESHOOTING

NEMT0052

FS5W71C

NVH Troubleshooting Chart

NVH Troubleshooting Chart

NEMT0052S01

Use the chart below to help you find the cause of the symptom. The numbers indicate the order of the inspection. If necessary, repair or replace these parts.

MANUAL TRANSMISSION

NEMT0052S0101

Reference page				Refer to MA-37 , "Checking M/T Oil".	MT-11	MT-11	MT-13	MT-13	MT-12	MT-12	MT-12	MT-12
SUSPECTED PARTS (Possible cause)		OIL (Oil level is low.)	OIL (Wrong oil.)	OIL (Oil level is high.)	GASKET (Damaged)	OIL SEAL (Worn or damaged)	CHECK PLUG RETURN SPRING AND CHECK BALL (Worn or damaged)	SHIFT FORK (Worn)	GEAR (Worn or damaged)	BEARING (Worn or damaged)	BAULK RING (Worn or damaged)	INSERT SPRING (Damaged)
Symptom	Noise	1	2						3	3		
	Oil leakage		3	1	2	2						
	Hard to shift or will not shift		1	1							2	2
	Jumps out of gear						1	2	2			

Cross-sectional View

- GI
- MA
- EM
- LC
- EC
- FE
- CL
- MT**
- AT
- TF
- PD
- AX
- SU
- BR
- ST
- RS
- BT
- HA
- SC
- EL
- IDX

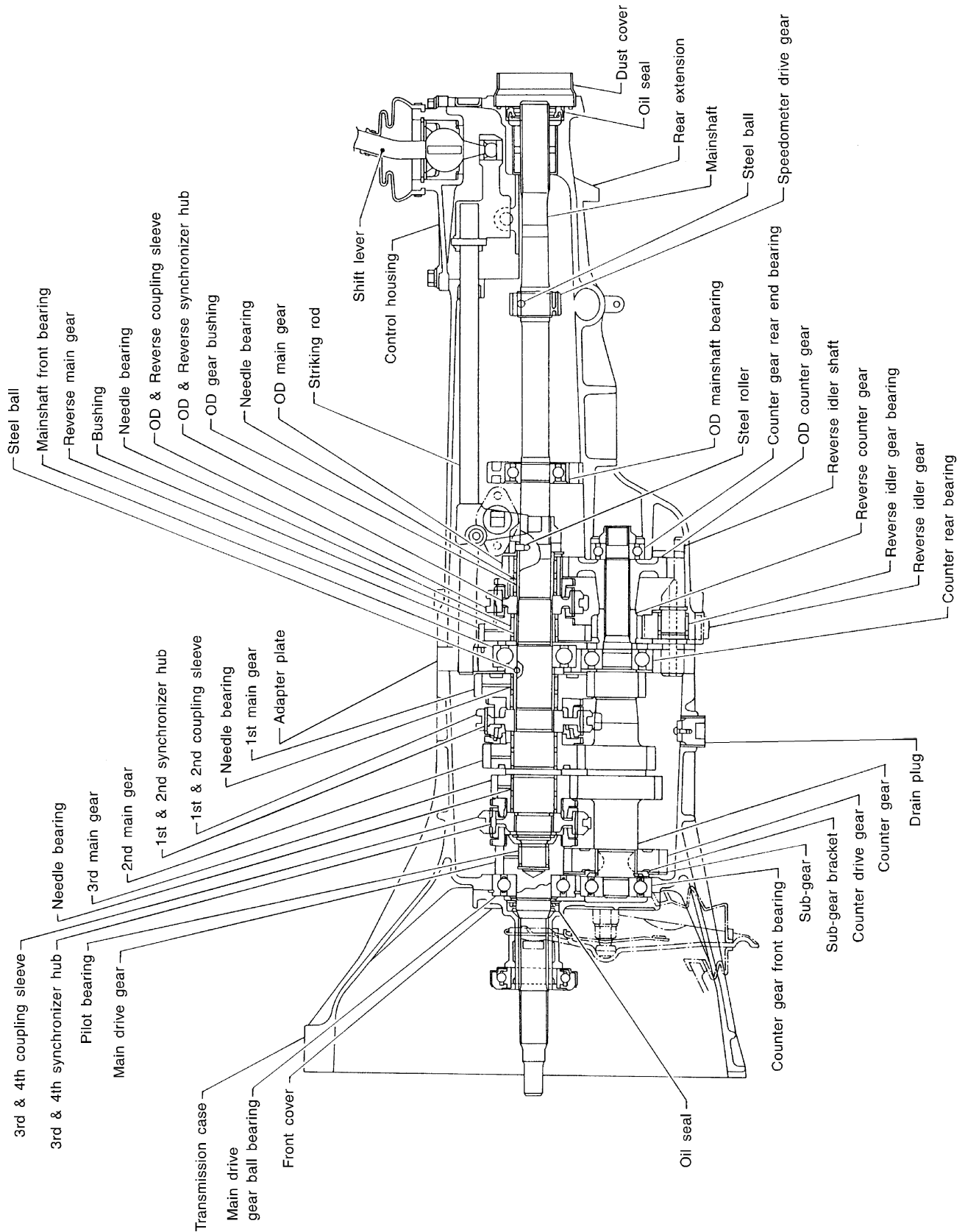

Replacing Rear Oil Seal

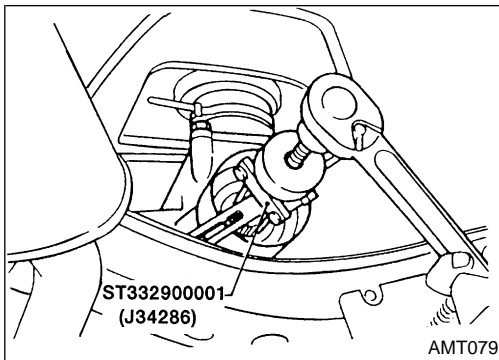

Replacing Rear Oil Seal

NEMT0054

REMOVAL

NEMT0054S01

1. Remove the propeller shaft. Refer to **PD-9**, "Removal and Installation".
2. Remove rear oil seal using Tool.
 - **Always replace with a new seal once it has been removed.**

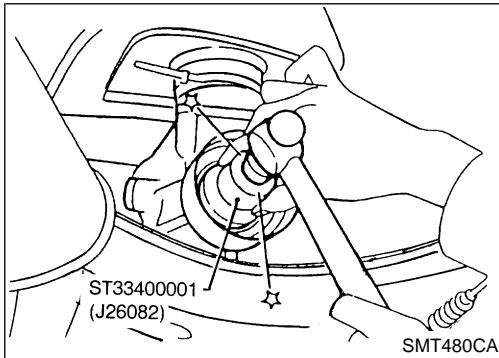

INSTALLATION

NEMT0054S02

1. Install new oil seal until it stops.
 - **Apply multi-purpose grease to seal lip of oil seal before installing.**
2. Install any part removed.

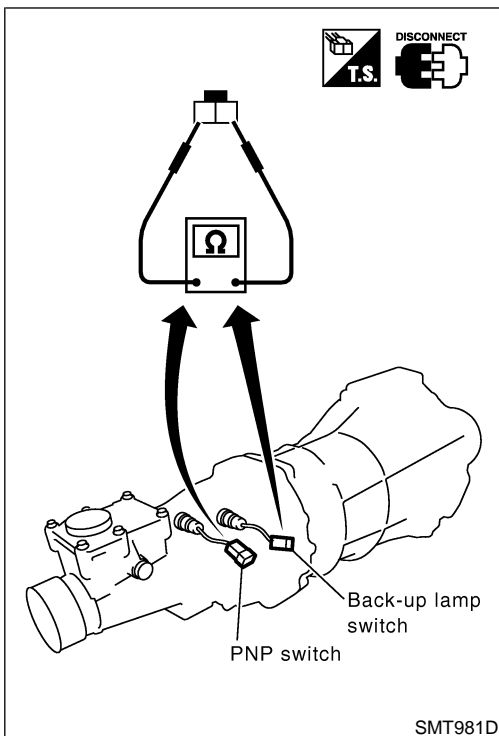

Position Switch Check

NEMT0055

- Check continuity.

Switch	Gear position	Continuity
Back-up lamp switch	Reverse	Yes
	Except reverse	No
Park/neutral position (PNP) switch	Neutral	Yes
	Except neutral	No

Removal

NEMT0056S01

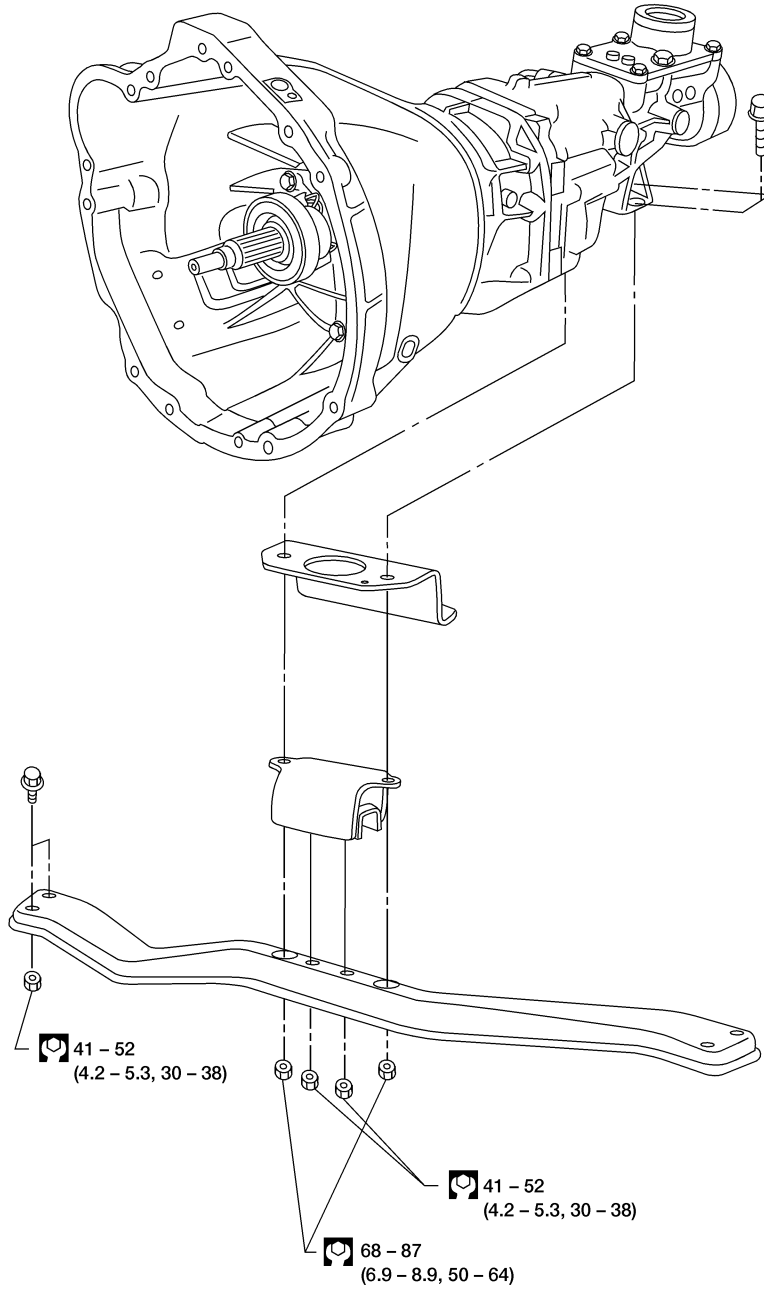

: N·m (kg-m, ft-lb)

WMT030

CAUTION:

Before separating the transmission from the engine, remove the crankshaft position sensor (OBD) from the transmission. Be careful not to damage sensor edge or ring gear teeth.

GI

MA

EM

LC

EC

FE

CL

MT

AT

TF

PD

AX

SU

BR

ST

RS

BT

HA

SC

EL

IDX

NOTE:

To prevent oil spills, drain transmission oil before removing transmission or insert plug into rear oil seal after removing propeller shaft.

- Be careful not to damage spline, sleeve yoke, and rear oil seal when removing propeller shaft.

1. Remove battery negative terminal.
2. Remove the crankshaft position sensor (OBD) from transmission upper side.
3. Remove the clutch operating cylinder from transmission.
4. Disconnect the vehicle speed sensor, back-up switch, and park/neutral position (PNP) switch harness connectors.
5. Remove the starter motor from transmission.
6. Disconnect the exhaust hanger.
7. Remove the propeller shaft. Refer to **PD-9**, "Removal and Installation".

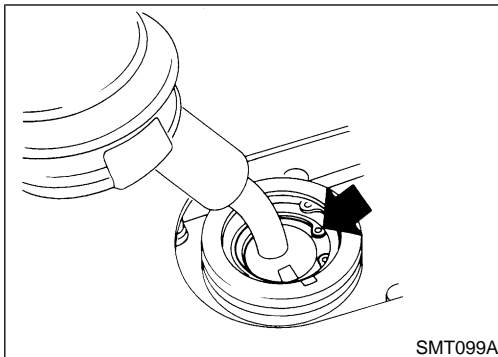

8. Remove the shift lever.
9. Support the engine by placing a jack under the oil pan.
- Do not place jack under oil pan drain plug.
10. Remove the transmission crossmember.
11. Separate the transmission from the engine.

WARNING:

Support manual transmission while removing it.

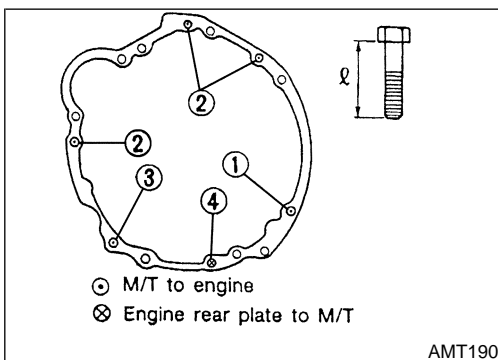

Installation

NEMT0056S02

1. Tighten bolts securing transmission.

Bolt No.	Tightening torque N-m (kg-m, ft-lb)	ℓ mm (in)
1	39 - 49 (4.0 - 5.0, 29 - 36)	65 (2.56)
2	39 - 49 (4.0 - 5.0, 29 - 36)	58 (2.28)
3*	16 - 22 (1.6 - 2.2, 12 - 16)	25 (0.98)
4	16 - 22 (1.6 - 2.2, 12 - 16)	16 (0.63)

*: With nut

2. Tighten clutch operating cylinder to the specified torque. Refer to **CL-5**, "CLUTCH SYSTEM".

Case Components

NEMT0057S01

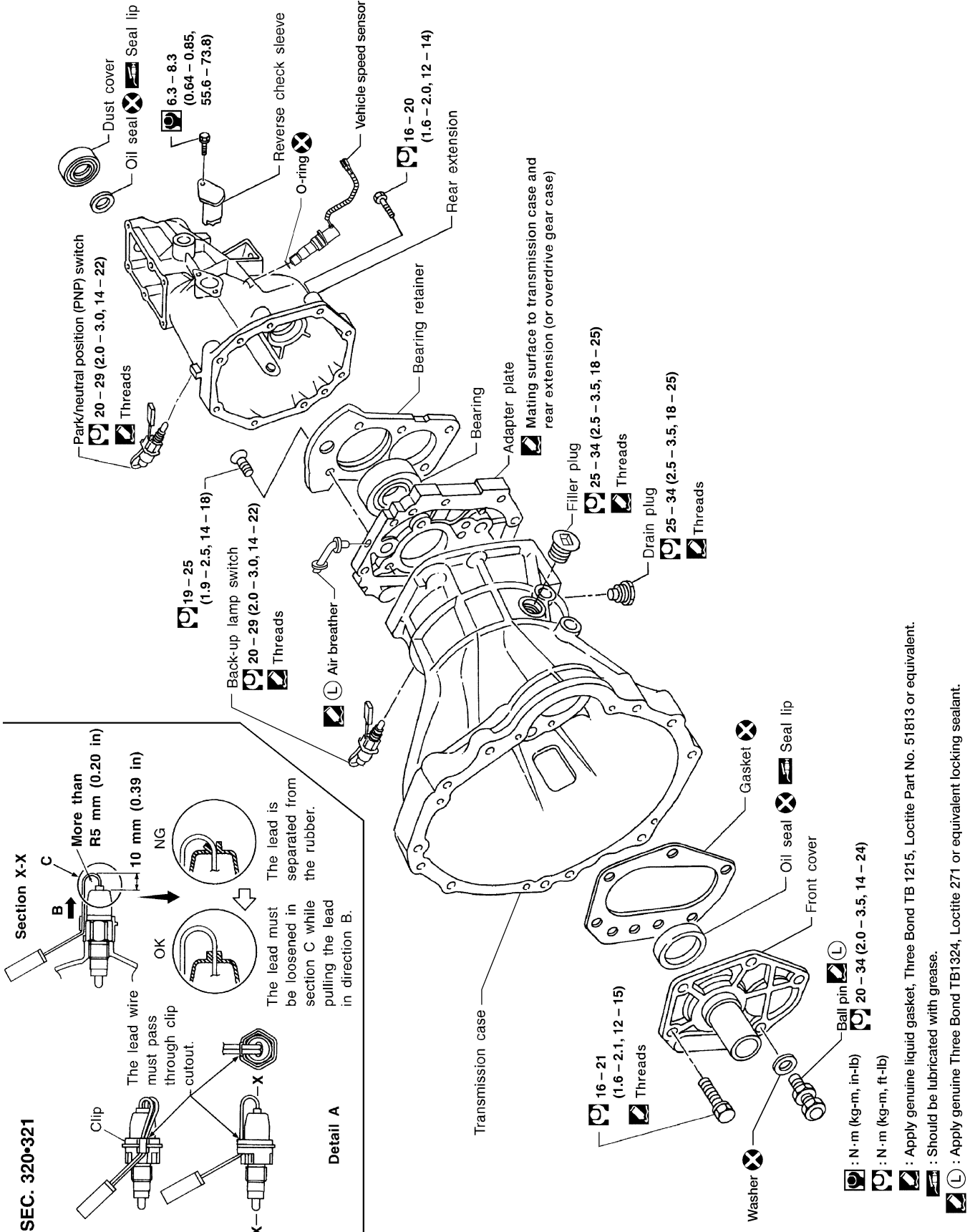

- GI
- MA
- EM
- LC
- EC
- FE
- CL
- MT**
- AT
- TF
- PD
- AX
- SU
- BR
- ST
- RS
- BT
- HA
- SC
- EL
- IDX

⊙ : N·m (kg-m, in-lb)

⊚ : N·m (kg-m, ft-lb)

⊛ : Apply genuine liquid gasket, Three Bond TB 1215, Loctite Part No. 51813 or equivalent.

⊜ : Should be lubricated with grease.

⊝ : Apply genuine Three Bond TB1324, Loctite 271 or equivalent locking sealant.

WMT055

Gear Components

NEMT0057S02

SEC. 322

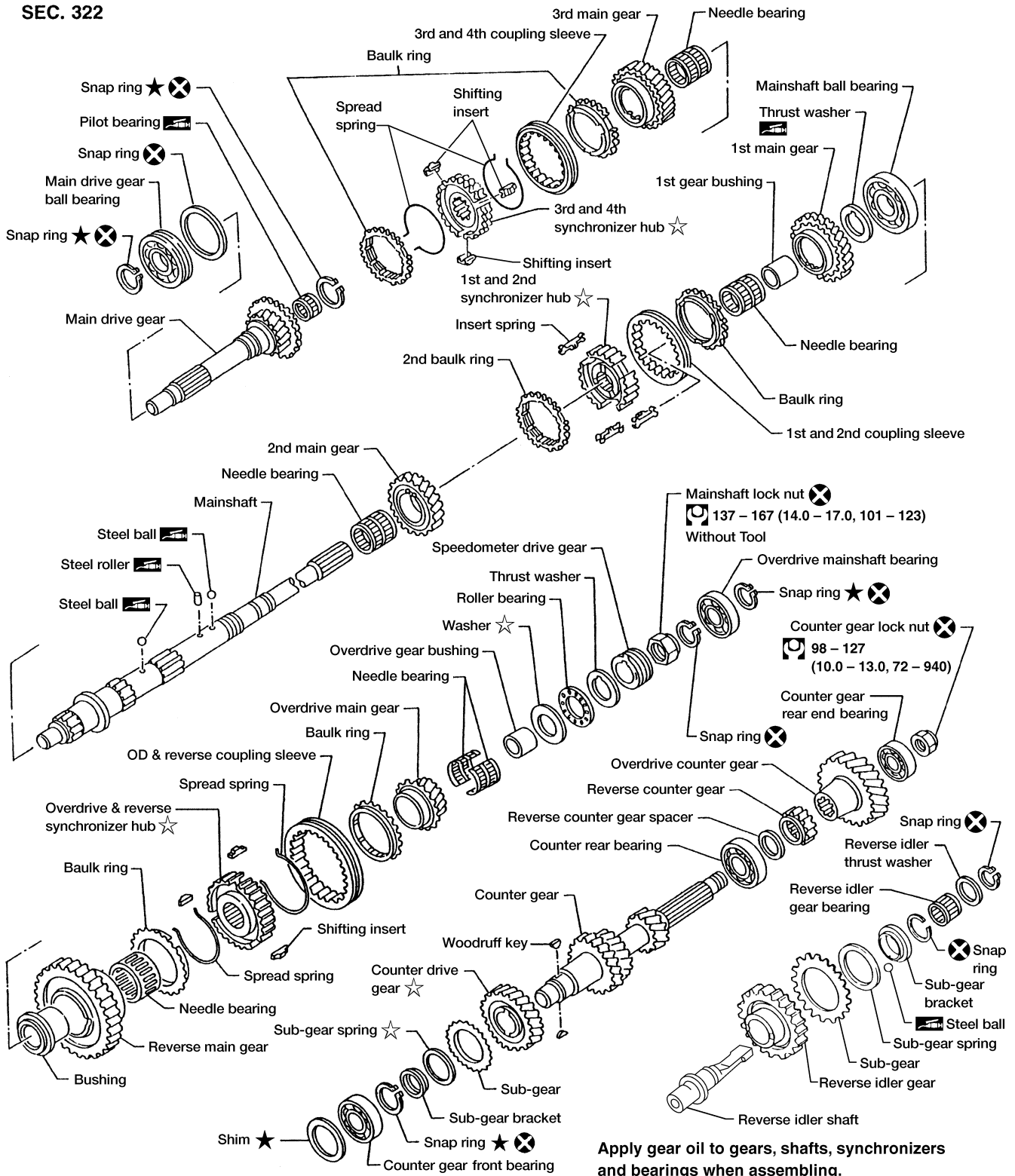

Apply gear oil to gears, shafts, synchronizers and bearings when assembling.

★ : Select proper thickness.

☆ : Pay attention to its direction.

⊗ : N · m (kg-m, ft-lb)

⊗ : Should be lubricated with grease.

Shift Control Components

NEMT0057S03

CAUTION:

To avoid damage when replacing shift knob, remove shift lever with knob, as assembled.

GI

MA

EM

LC

EC

FE

CL

MT

AT

TF

PD

AX

SU

BR

ST

RS

BT

HA

SC

EL

IDX

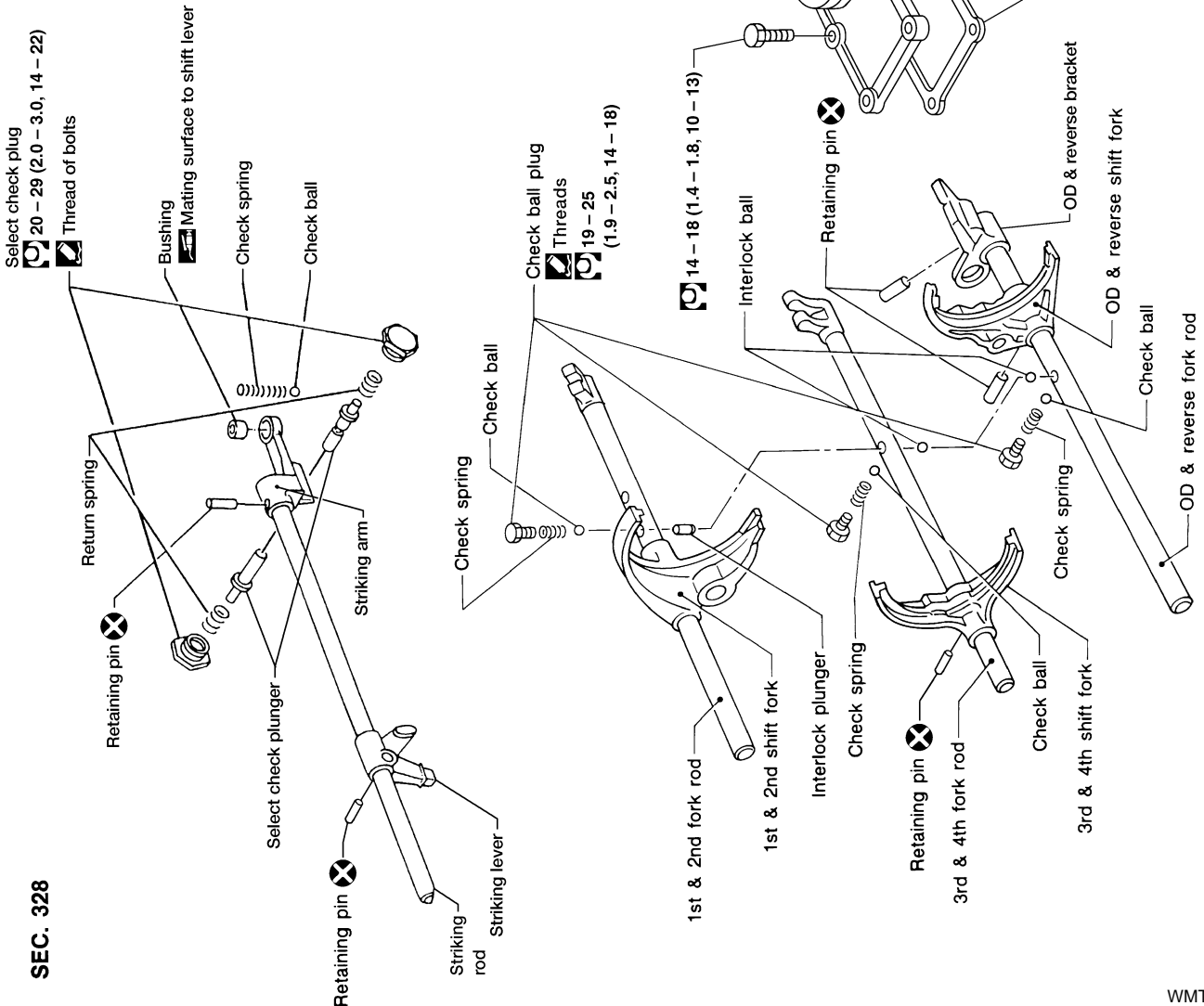

SEC. 328

WMT040

Case Components

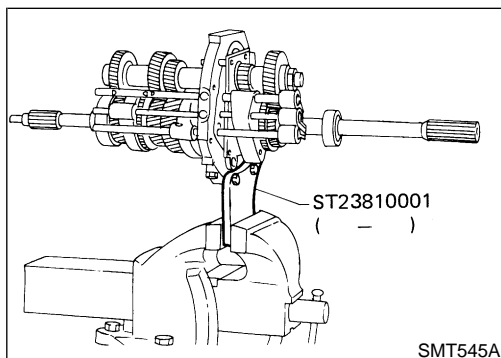
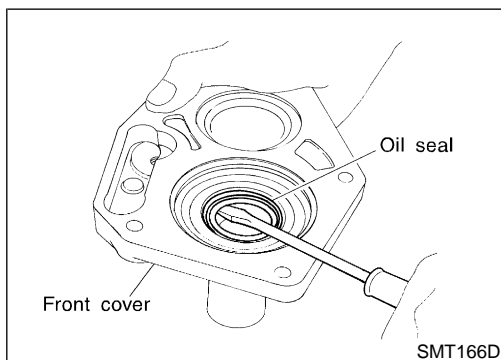
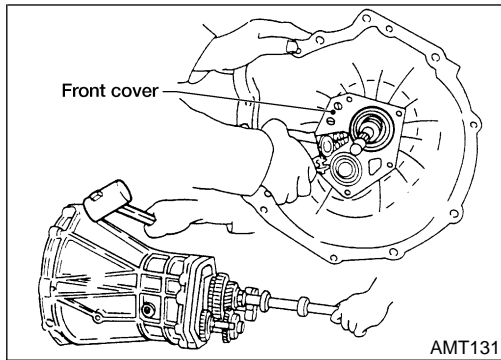
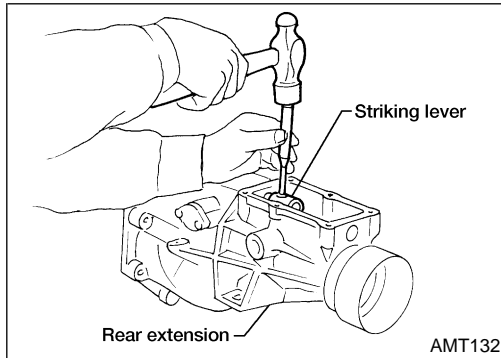
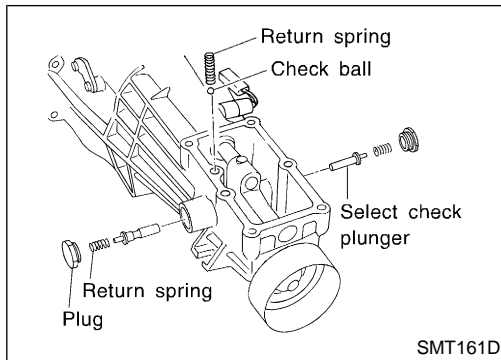

Case Components DISASSEMBLY

NEMT0058

1. Remove rear extension.
 - a. Remove control housing, check ball, return spring plugs, select check plungers and return springs. Also remove reverse check plug, check spring and check ball.

- **Be careful not to lose check balls.**

- b. Drive out striking lever retaining pin.
- c. Remove striking lever from striking rod.
- d. Remove rear extension by lightly tapping on it.

2. Remove front cover, gasket, counter gear front bearing shim and main drive gear ball bearing snap ring.
3. Separate transmission case from adapter plate by lightly tapping on it.

4. Remove oil seal from front cover.
 - **Be careful not to damage mating surface of front cover.**

Shift Control Components DISASSEMBLY

NEMT0059

1. Set up Tool on adapter plate.
2. Remove striking rod from adapter plate.
3. Remove check ball plugs, check springs, and check balls.

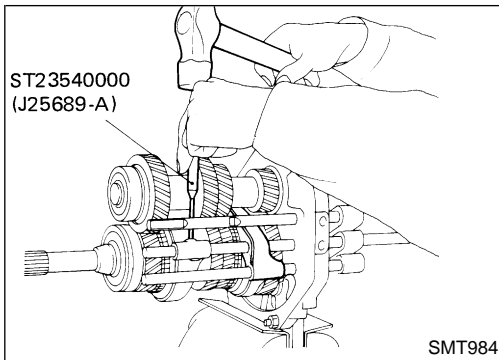

4. Drive out retaining pins. Then drive out fork rods and remove interlock balls.

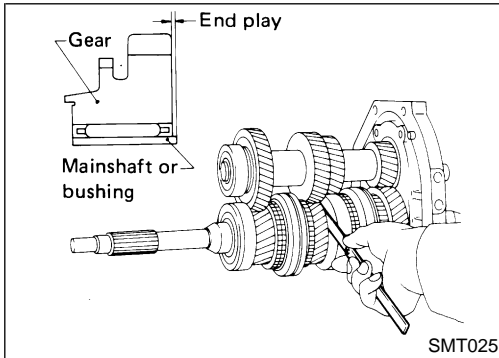

Gear Components DISASSEMBLY

1. Before disassembly, measure the end play of each gear. NEMT0060
 - If end play is not within the specified limit, disassemble and inspect the parts.
 - Replace any part which is worn or damaged. Refer to "Gear End Play", MT-30.

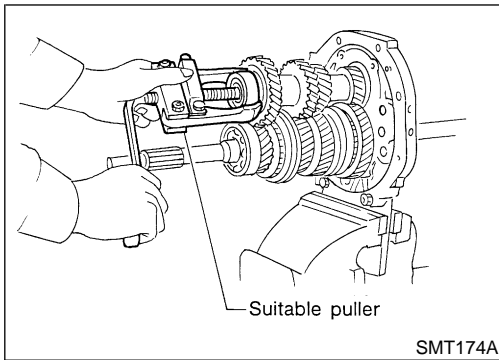

2. Mesh 2nd and reverse gear, then remove counter gear front bearing using a suitable puller.
3. Remove snap ring, then remove sub-gear bracket, sub-gear spring and sub-gear.

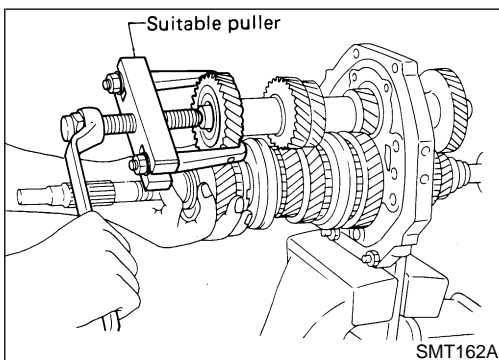

4. Remove counter drive gear together with main drive gear assembly using a suitable puller.
 - **When removing main drive gear assembly, be careful not to drop pilot bearing or baulk ring.**
5. Remove snap ring, then remove 3rd and 4th synchronizer assembly and 3rd main gear.

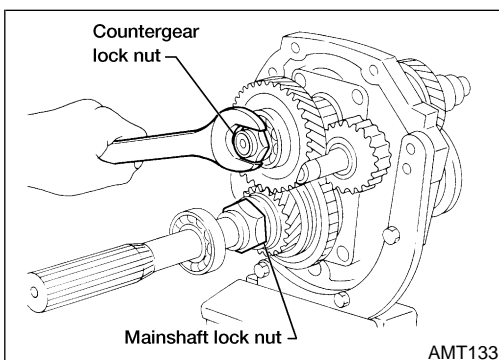

6. Disassemble parts at rear of adapter plate as follows:
 - a. Release staking on both countergear and mainshaft lock nuts, then loosen both nuts.

Mainshaft lock nut: Left-hand thread

GI
MA
EM
LC
EC
FE
CL
MT
AT
TF
PD
AX
SU
BR
ST
RS
BT
HA
SC
EL
IDX

Gear Components (Cont'd)

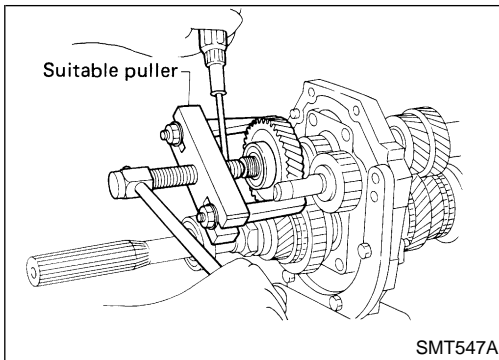

- b. Remove overdrive counter gear together with counter gear rear end bearing using a suitable puller.
- c. Remove reverse counter gear and spacer.
- d. Remove snap rings from reverse idler shaft, then remove reverse idler gear, thrust washers and reverse idler gear bearing.

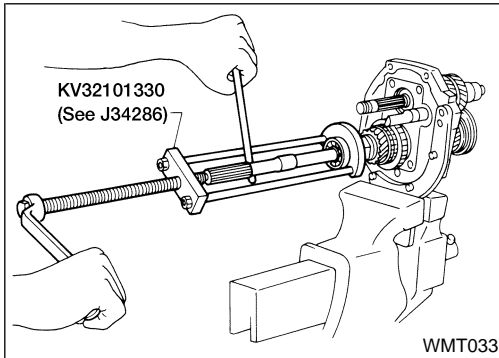

- e. Remove snap ring and pull out overdrive mainshaft bearing, then remove snap ring. (2WD model)
- f. Remove mainshaft lock nut.
- g. Remove speedometer drive gear and steel ball. (2WD model)
- h. Remove thrust washer, steel roller, roller bearing and washer.
- i. Remove overdrive main gear, needle bearing and baulk ring (overdrive).
- j. Remove counter gear by tapping on rear end of counter gear.
- k. Press out overdrive gear bushing and overdrive & reverse synchronizer assembly.
- l. Remove reverse main gear and needle bearing.
- m. Press out reverse gear bushing.

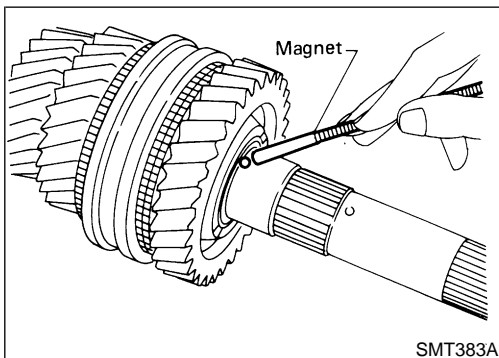
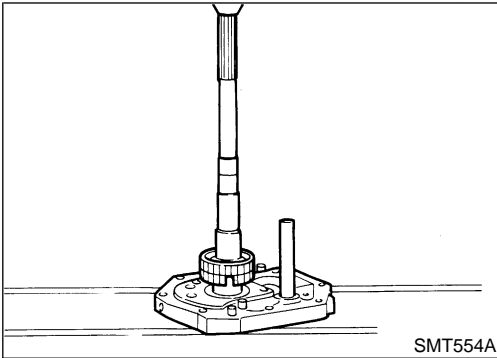

7. Remove thrust washer, steel ball, 1st main gear and needle bearing.
 - **Be careful not to lose steel ball.**

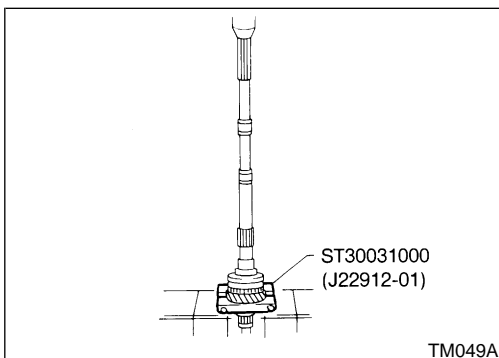

8. Press out 1st gear bushing together with 2nd main gear using Tool. Remove 2nd gear needle bearing.

DISASSEMBLY

FS5W71C

Gear Components (Cont'd)

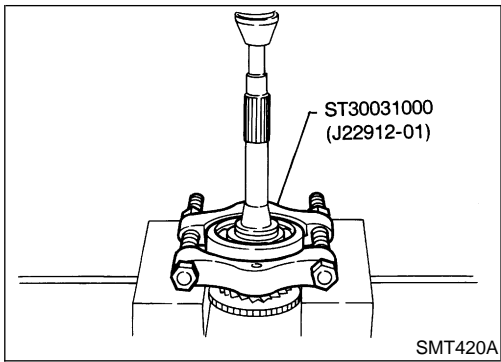

9. Remove main drive gear ball bearing.
 - a. Remove snap ring.
 - b. Remove main drive gear ball bearing.

GI

MA

EM

LC

EC

FE

CL

MT

AT

TF

PD

AX

SU

BR

ST

RS

BT

HA

SC

EL

IDX

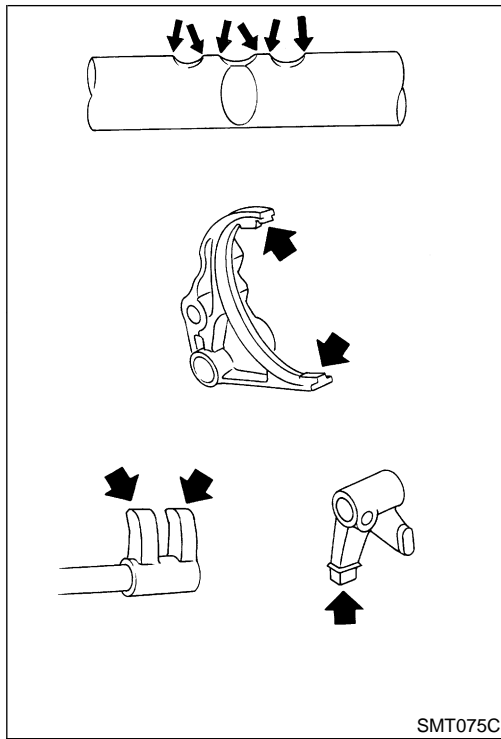

Shift Control Components

INSPECTION

- Check contact and sliding surfaces of fork rods for wear, scratches, projections and other damage. NEMT0061

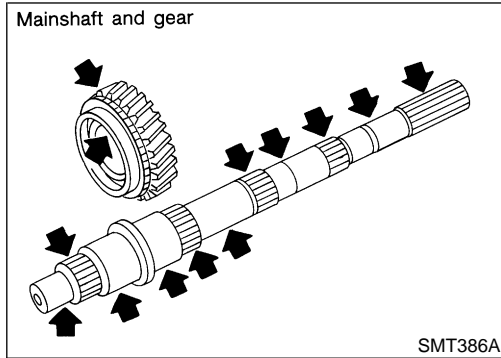

Gear Components

INSPECTION

Gears and Shafts

- Check shafts for cracks, wear and bending. NEMT0062
- Check gears for excessive wear, chips and cracks. NEMT0062S01

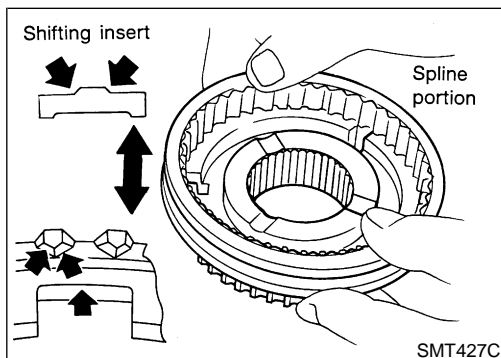
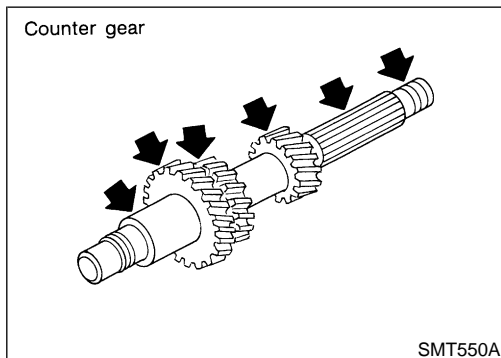

Synchronizers

- Check spline portion of coupling sleeves, synchronizer hubs, and gears for wear, chips, and cracks. NEMT0062S02
- Check baulk rings for cracks and deformation.
- Check shifting inserts for wear and deformation.
- Check insert spread springs for deformation.

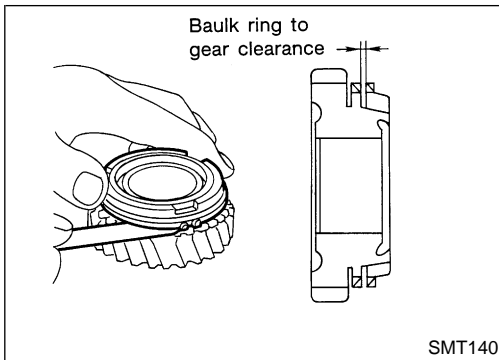

- Measure baulk ring wear.
- 1) Measure clearance between baulk ring and gear.
 - **Clearance between baulk ring and gear:**
 Refer to “Clearance Between Baulk Ring and Gear”, MT-31.
 - If the clearance is less than the wear limit, replace baulk ring.

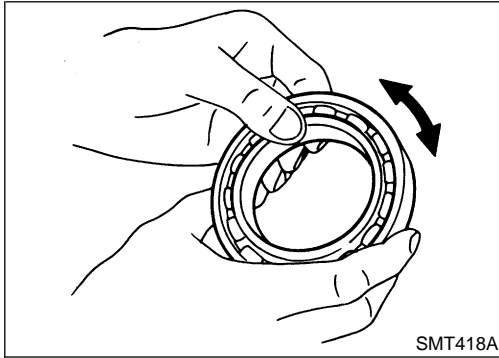

Bearings

- Make sure all bearings roll freely and are free from noise, cracks, pitting or wear. NEMT0062S03

GI

MA

EM

LC

EC

FE

CL

MT

AT

TF

PD

AX

SU

BR

ST

RS

BT

HA

SC

EL

IDX

Gear Components ASSEMBLY

NEMT0063

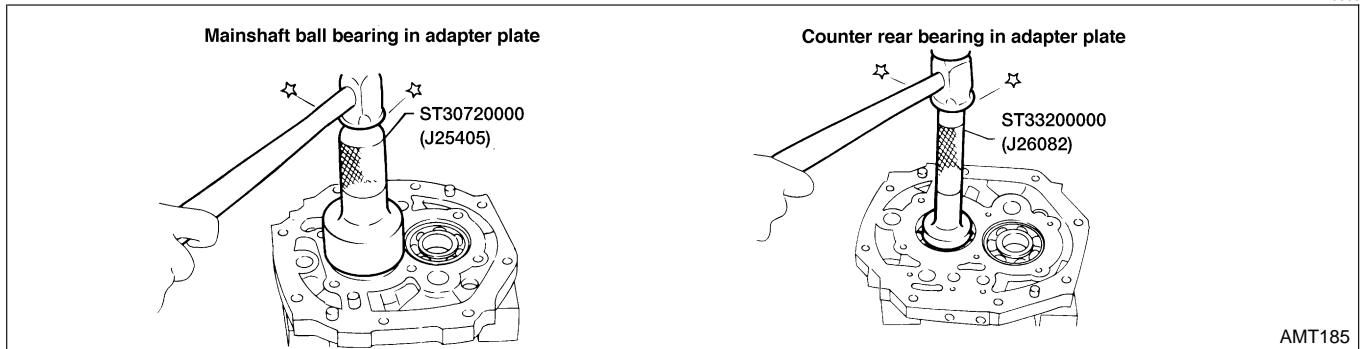

AMT185

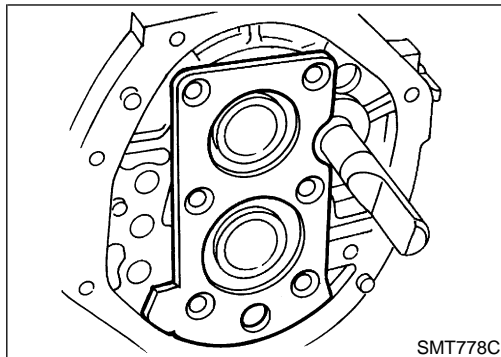

SMT778C

1. Install bearings into case components.
2. Assemble adapter plate parts.
 - Install oil gutter on adapter plate and expand on rear side.
 - Install bearing retainer.
 - a. Insert reverse idler shaft, then install bearing retainer.

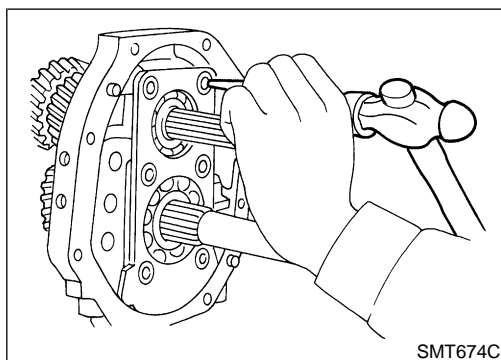

SMT674C

- b. Tighten each screw, then stake each one at two points.

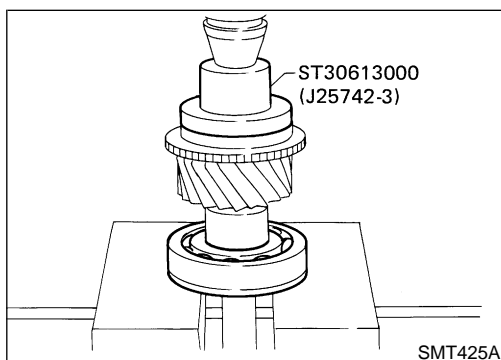

SMT425A

3. Install main drive gear ball bearing.
 - a. Press main drive gear ball bearing.

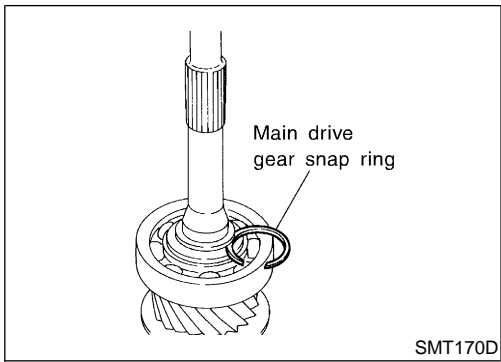

- b. Select and install proper main drive gear snap ring to achieve proper clearance of groove.

Allowable clearance of groove:

0 - 0.13 mm (0 - 0.0051 in)

Main drive gear bearing snap ring:

Refer to "MAIN DRIVE GEAR BEARING", MT-31.

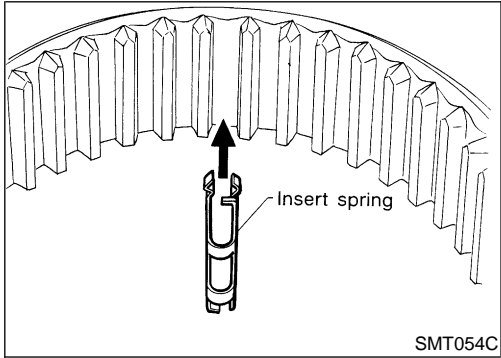

4. Assemble synchronizers.
- Assemble the 1st and 2nd synchronizer.

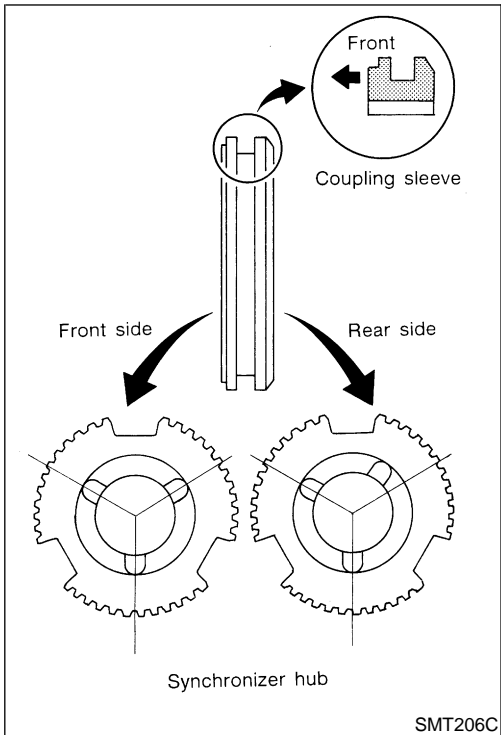

- Check coupling sleeve and synchronizer hub orientation.

GI

MA

EM

LC

EC

FE

CL

MT

AT

TF

PD

AX

SU

BR

ST

RS

BT

HA

SC

EL

IDX

Gear Components (Cont'd)

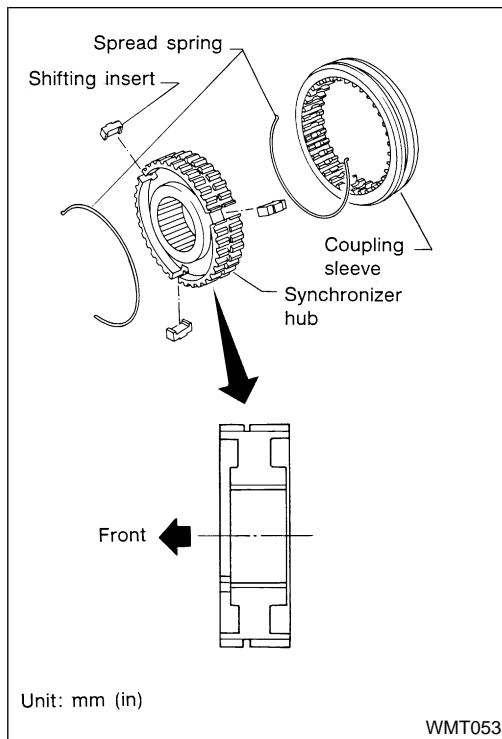

- Assemble the 3rd and 4th synchronizer.

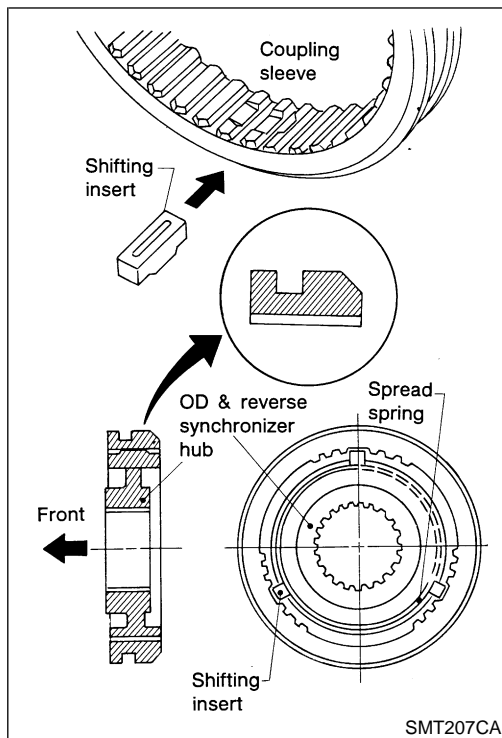

- Assemble the overdrive and reverse synchronizer.

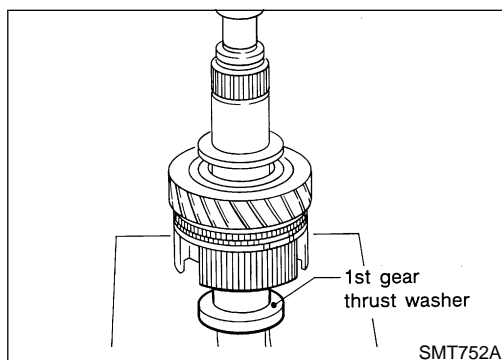

5. Assemble front side components to mainshaft.
 - a. Install 2nd main gear, needle bearing and 1st and 2nd synchronizer assembly; then press 1st gear bushing onto the mainshaft.
 - b. Install 1st main gear.

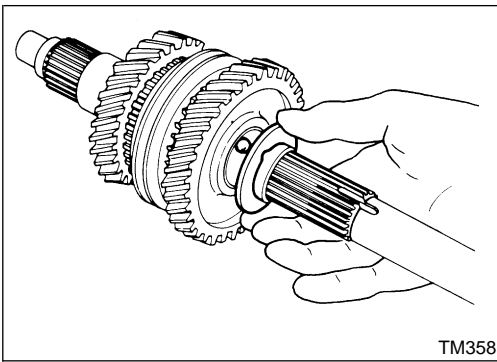

- c. Install steel ball and 1st gear washer.
- Before installation, apply multi-purpose grease to steel ball and to both sides of the 1st gear washer.

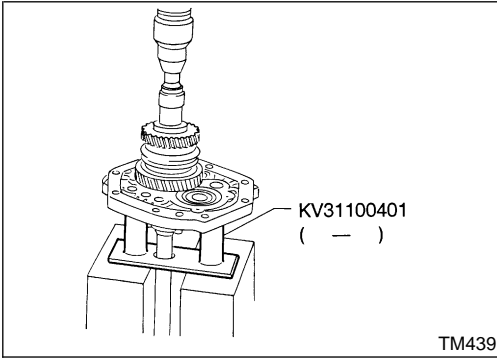

6. Install mainshaft and counter gear on adapter plate and main drive gear on mainshaft as follows:
- a. Press mainshaft assembly into adapter plate using Tool.

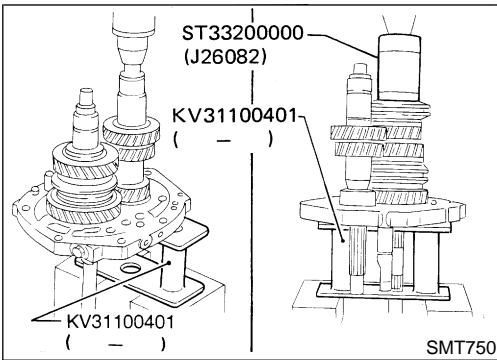

- b. Press counter gear into adapter plate using Tool.
- c. Install 3rd main gear and needle bearing, then press 3rd and 4th synchronizer assembly onto mainshaft.
- Pay attention to the direction of 3rd and 4th synchronizer.

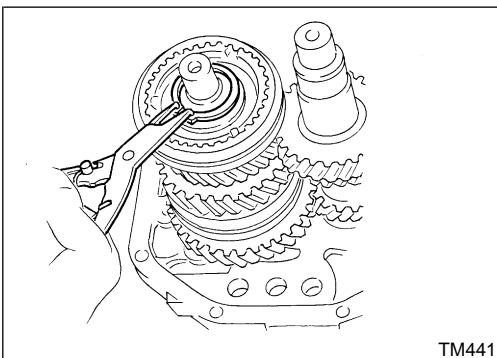

- d. Install front mainshaft snap ring.
Select proper front mainshaft snap ring to achieve proper clearance of groove.

Allowable clearance of groove:

0 - 0.18 mm (0 - 0.0071 in)

Mainshaft front snap ring:

Refer to "MAINSHAFT FRONT", MT-31.

- e. Apply gear oil to mainshaft pilot bearing and install it on mainshaft.

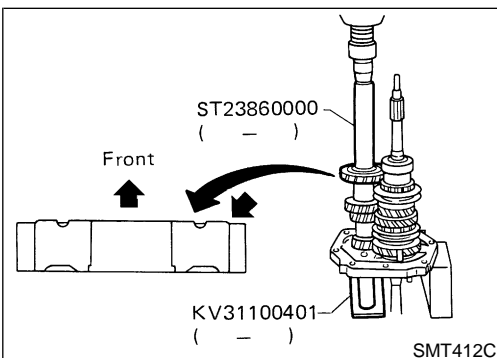

- f. Press counter drive gear together with main drive gear using Tool.
- Pay attention to the direction of counter drive gear.

Gear Components (Cont'd)

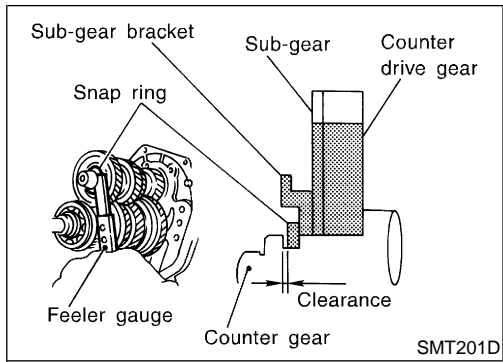

- g. Install sub-gear components.
- i. Install sub-gear and sub-gear bracket on counter drive gear and then select proper snap ring that will minimize clearance of groove in counter gear.

- **Do not install sub-gear spring at this time.**

Allowable clearance of groove:

0 - 0.13 mm (0 - 0.0051 in)

Counter drive gear snap ring:

Refer to "COUNTER DRIVE GEAR", MT-31.

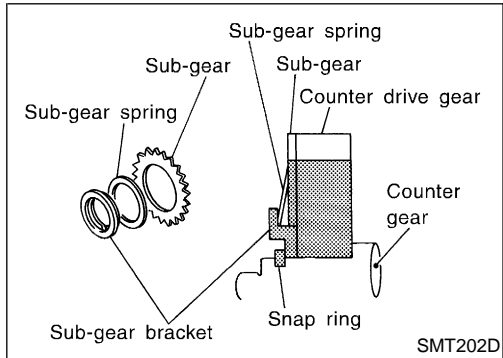

- ii. Remove snap ring, sub-gear bracket and sub-gear from counter gear.
- iii. Reinstall sub-gear, sub-gear spring, sub-gear bracket and snap ring.

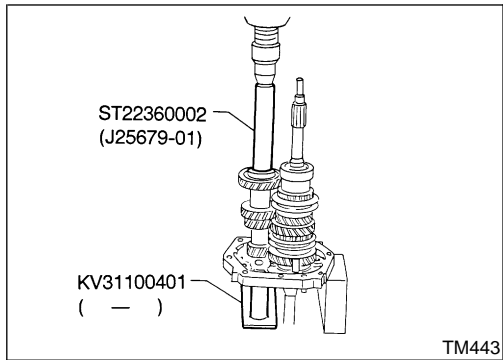

- h. Press counter/gear front bearing onto counter gear using Tool.

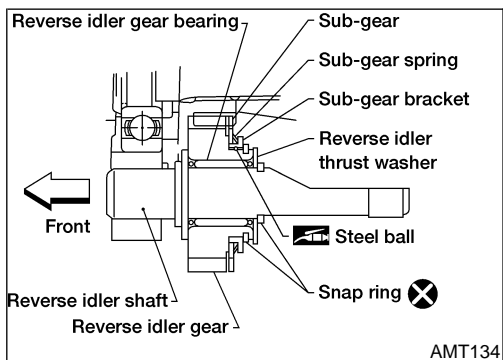

- 7. Install rear side components on mainshaft and counter gear as follows:
 - a. Install sub-gear parts (sub-gear, sub-gear spring, sub-gear bracket, steel ball and snap ring) on the reverse idler gear.
 - b. Install reverse idler gear to reverse idler shaft along with reverse idler thrust washer, snap rings and reverse idler gear bearing.

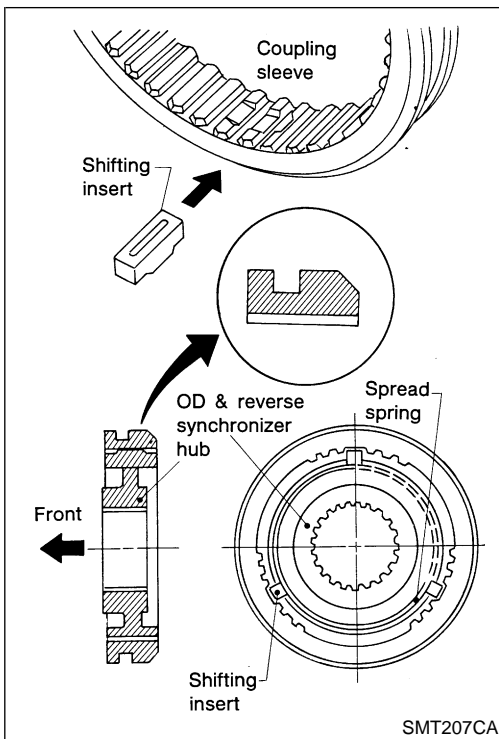

- c. Install bushing, reverse main gear and overdrive and reverse synchronizer to mainshaft.

- **Pay attention to the direction of synchronizer hub.**

GI

MA

EM

LC

EC

FE

CL

MT

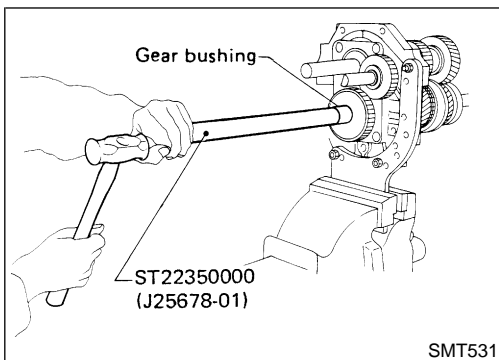

- d. Install overdrive gear bushing to mainshaft using Tool.

- e. Install overdrive main gear and needle bearing to mainshaft.

- f. Install spacer, reverse counter gear and overdrive counter gear to counter/gear.

- **OD main gear and OD counter gear should be handled as a matched set.**

- g. Install washer, roller bearing, steel roller and thrust washer.

- h. Tighten mainshaft lock nut temporarily.

- **Always use new lock nut.**

AT

TF

PD

AX

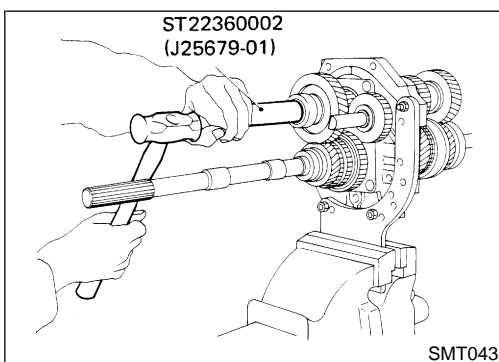

- i. Install counter/gear rear end bearing using Tool.

SU

BR

ST

RS

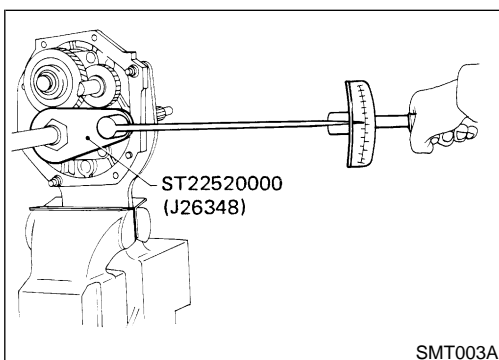

8. Mesh 2nd and reverse gears, then tighten mainshaft lock nut using Tool.

- **Always use new lock nut.**

Mainshaft lock nut:

 : 137 - 167 N·m (14.0 - 17.0 kg·m, 101 - 123 ft·lb)

BT

HA

SC

EL

IDX

Gear Components (Cont'd)

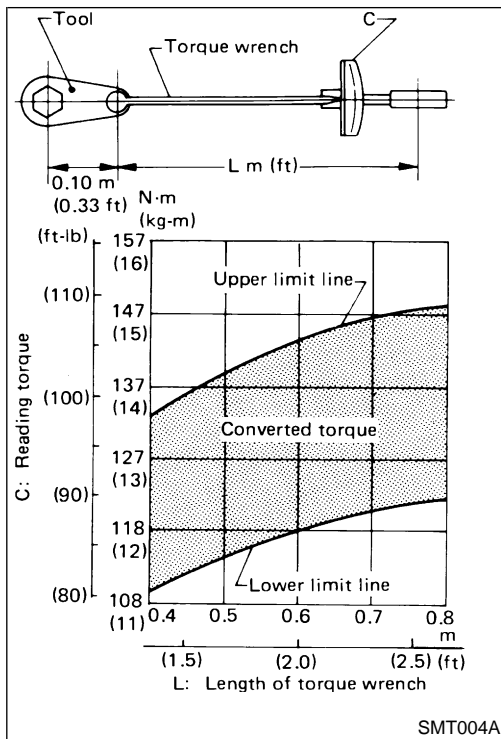

- Use the chart shown at left to determine the proper reading torque.
(Length of torque wrench vs. setting or reading torque)
Reference: Formula to convert torque wrench indication to the true torque value:
 $T = (0.1 \text{ m (0.33 ft)} + L) / L \times C$
If the specified torque is T kg-m (ft-lb), the torque wrench scale indication C is determined using the following formula:
 $C = (T \times L) / (0.1 \text{ m (0.33 ft)} + L)$

9. Tighten counter gear lock nut.

- Always use new lock nut.**

Counter gear lock nut:

: 98 - 127 N-m (10.0 - 13.0 kg-m, 72 - 94 ft-lb)

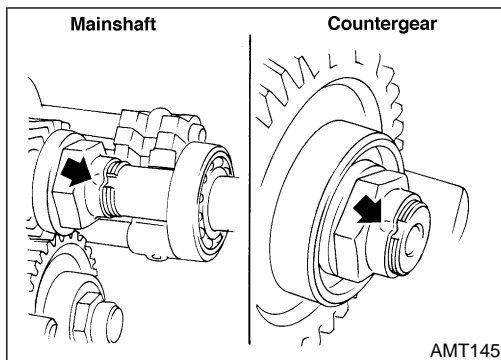

10. Stake mainshaft lock nut and counter gear lock nut using a punch.

11. Measure gear end play. Refer to "DISASSEMBLY", MT-15.

12. Install snap ring and OD mainshaft bearing, then snap ring.

Allowable clearance:

0 - 0.14 mm (0 - 0.0055 in)

OD mainshaft bearing snap ring:

Refer to "OD MAINSHAFT BEARING", MT-32.

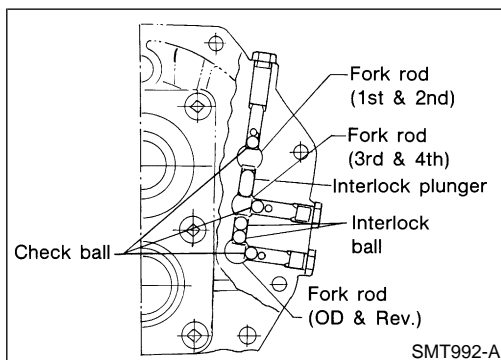

Shift Control Components

ASSEMBLY

1. Install fork rods, interlock plunger, interlock balls and check balls. NEMT0064

2. Install 1st and 2nd shift fork, then drive in retaining pin.

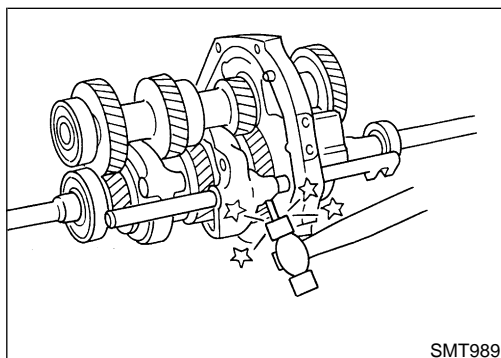

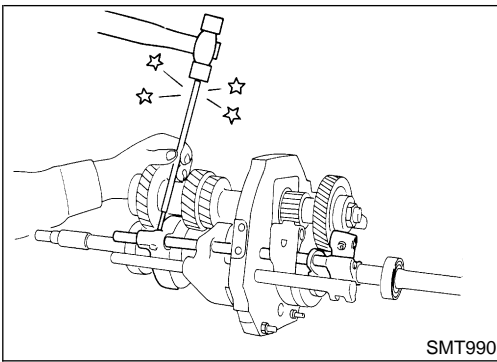

SMT990

3. Install 3rd and 4th shift fork, then drive in retaining pin.

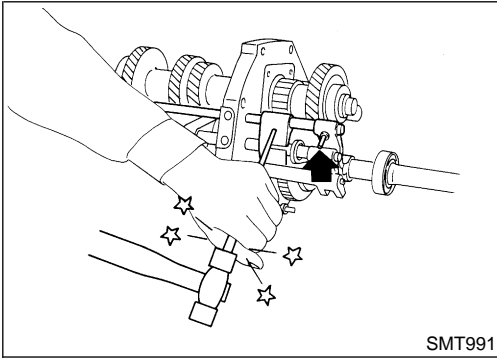

SMT991

4. Install overdrive and reverse shift fork, then drive in retaining pin.

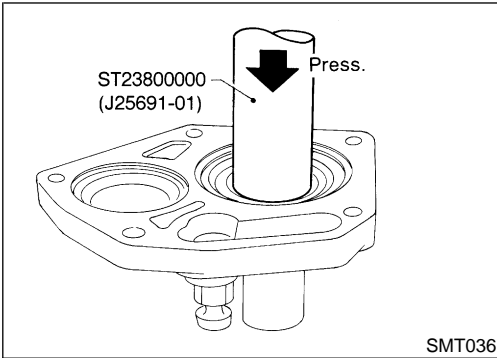

SMT036

Case Components

ASSEMBLY

NEMT0065

1. Install front cover oil seal using Tool.
 - Apply multi-purpose grease to seal lip.

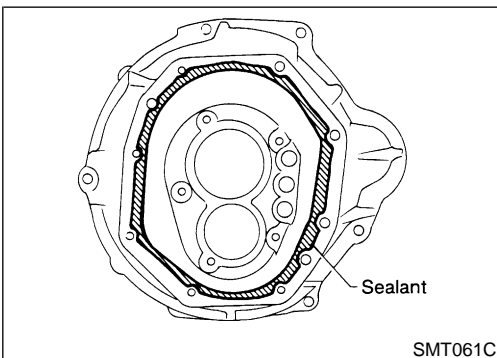

SMT061C

2. Apply sealant to mating surface of transmission case as shown in the figure at left.
 - Use genuine anaerobic liquid gasket, Three Bond TB1215, Loctite Part No. 51813 or equivalent.

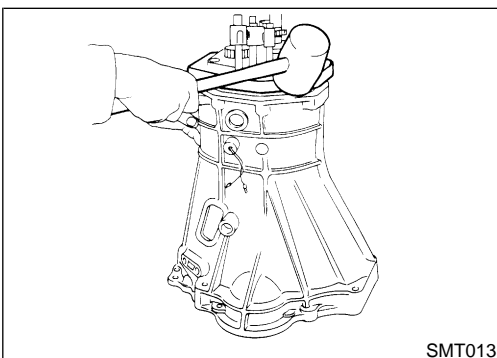

SMT013

3. Slide gear assembly onto adapter plate by lightly tapping it using a soft hammer.

GI

MA

EM

LC

EC

FE

CL

MT

AT

TF

PD

AX

SU

BR

ST

RS

BT

HA

SC

EL

IDX

Case Components (Cont'd)

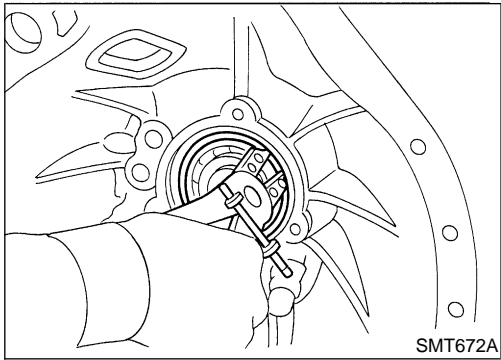

4. Install main drive gear ball bearing snap ring.

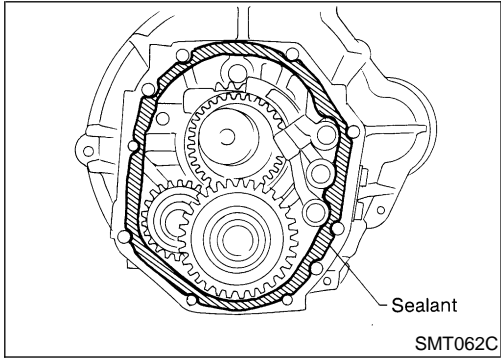

5. Apply sealant to mating surface of adapter plate as shown at left.
 - Use genuine anaerobic liquid gasket Three Bond TB1215, Loctite Part No. 51813 or equivalent.

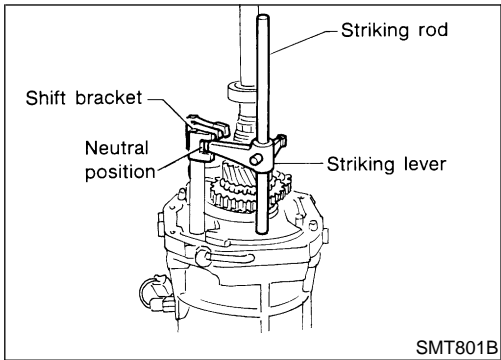

6. Place shift forks in neutral position.
7. Install striking lever and rod onto adapter plate and align striking lever with shift brackets.

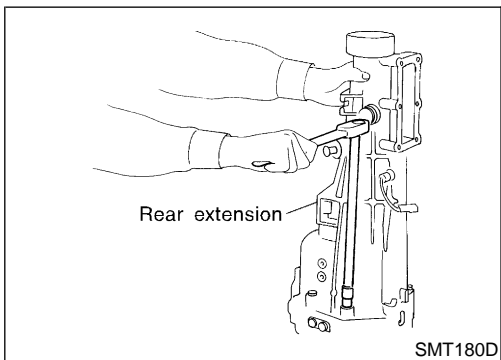

8. Install rear extension.
 - Tighten mounting bolts equally in a criss-cross pattern.

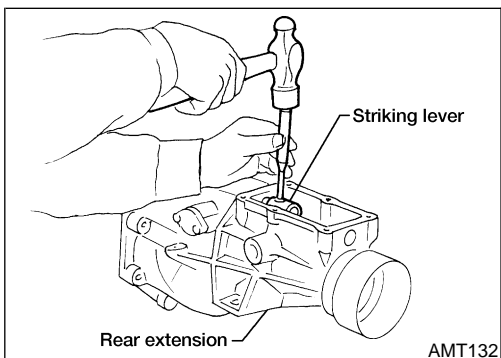

9. Install striking lever retaining pin.

ASSEMBLY

FS5W71C

Case Components (Cont'd)

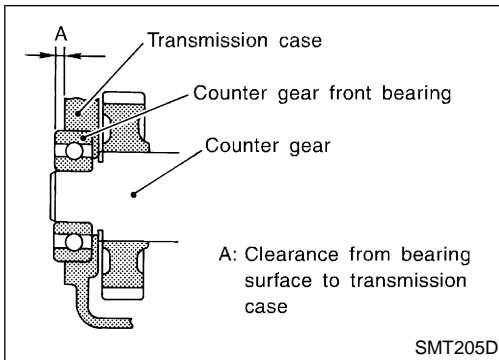

10. Select counter gear front bearing shim.

Allowable clearance (A) from bearing surface to transmission case:

0 - 0.16 mm (0 - 0.0063 in)

Countershaft front bearing shim:

Refer to "COUNTERSHAFT FRONT BEARING", MT-32.

11. Install gasket and front cover.

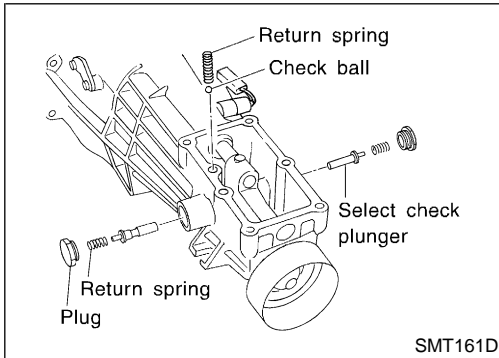

12. Install check ball, return springs, select check plungers and plugs.

13. Install control housing and gasket.

GI

MA

EM

LC

EC

FE

CL

MT

AT

TF

PD

AX

SU

BR

ST

RS

BT

HA

SC

EL

IDX

General Specifications

NEMT0066

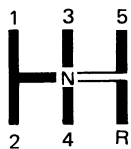
Applied model		KA24DE
		2WD
Transmission		FS5W71C
Number of speed		5
Shift pattern		 MT-SDS-2
Synchromesh type		Warner
Gear ratio	1st	3.321
	2nd	1.902
	3rd	1.308
	4th	1.000
	OD	0.838
	Reverse	3.382
Mainshaft (Number of teeth)	Drive	22
	1st	33
	2nd	27
	3rd	26
	OD	22
	Reverse	36
Countershaft gear (Number of teeth)	Drive	31
	1st	14
	2nd	20
	3rd	28
	OD	37
	Reverse	15
Reverse idler gear (Number of teeth)		21
Oil capacity ℓ (US pt, Imp pt)		2.0 (4-1/4, 3-1/2)
Remarks	Reverse synchronizer	Installed
	Sub gear	Counter drive gear and reverse idler gear

Gear End Play

NEMT0067
Unit: mm (in)

1st gear	0.31 - 0.41 (0.0122 - 0.0161)
2nd gear	0.11 - 0.21 (0.0043 - 0.0083)
3rd gear	0.11 - 0.21 (0.0043 - 0.0083)
Overdrive gear	0.24 - 0.41 (0.0094 - 0.0161)

SERVICE DATA AND SPECIFICATIONS (SDS)

FS5W71C

Clearance Between Baulk Ring and Gear

Clearance Between Baulk Ring and Gear

NEMT0068
Unit: mm (in)

Standard	1st & 2nd	1.20 - 1.60 (0.0472 - 0.0630)
	3rd & main drive	1.20 - 1.60 (0.0472 - 0.0630)
	Overdrive	1.20 - 1.60 (0.0472 - 0.0630)
	Reverse	1.10 - 1.55 (0.0433 - 0.0610)
Wear limit	1st & 2nd	0.80 (0.0315)
	3rd & main drive	0.80 (0.0315)
	Overdrive	0.80 (0.0315)
	Reverse	0.70 (0.0276)

Available Snap Rings

NEMT0069

MAIN DRIVE GEAR BEARING

NEMT0069S01
Unit: mm (in)

Allowable clearance 0 - 0.13 (0 - 0.0051)

Thickness	Part number*
1.87 (0.0736)	32204-78001
1.94 (0.0764)	32204-78002
2.01 (0.0791)	32204-78003

*Always check with the Parts Department for the latest parts information.

MAINSHAFT FRONT

NEMT0069S02
Unit: mm (in)

Allowable clearance 0 - 0.18 (0 - 0.0071)

Thickness	Part number*
2.4 (0.094)	32263-V5200
2.5 (0.098)	32263-V5201

*Always check with the Parts Department for the latest parts information.

COUNTER DRIVE GEAR

NEMT0069S03
Unit: mm (in)

Allowable clearance 0 - 0.13 (0 - 0.0051)

Thickness	Part number*
1.4 (0.055)	32215-E9000
1.5 (0.059)	32215-E9001
1.6 (0.063)	32215-E9002

*Always check with the Parts Department for the latest parts information.

GI

MA

EM

LC

EC

FE

CL

MT

AT

TF

PD

AX

SU

BR

ST

RS

BT

HA

SC

EL

IDX

SERVICE DATA AND SPECIFICATIONS (SDS)

FS5W71C

Available Snap Rings (Cont'd)

OD MAINSHAFT BEARING

NEMT0068S04
Unit: mm (in)

Allowable clearance 0 - 0.14 (0 - 0.0055)

Thickness	Part number*
1.1 (0.043)	32228-20100
1.2 (0.047)	32228-20101
1.3 (0.051)	32228-20102
1.4 (0.055)	32228-20103

*Always check with the Parts Department for the latest parts information.

Available Shims

COUNTERSHAFT FRONT BEARING

NEMT0070
NEMT0070S01
Unit: mm (in)

Allowable clearance "A" 0 - 0.16 (0 - 0.0063)

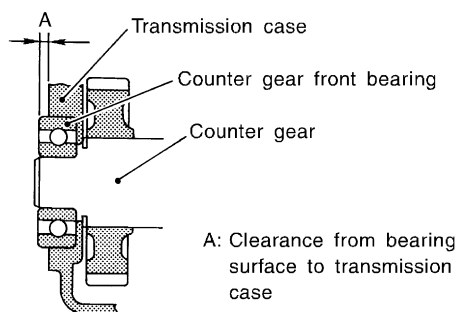

SMT205D

"A"	Thickness of shim	Part number*
4.52 - 4.71 (0.1780 - 0.1854)	Not necessary	
4.42 - 4.51 (0.1740 - 0.1776)	0.1 (0.004)	32218-V5000
4.32 - 4.41 (0.1701 - 0.1736)	0.2 (0.008)	32218-V5001
4.22 - 4.31 (0.1661 - 0.1697)	0.3 (0.012)	32218-V5002
4.12 - 4.21 (0.1622 - 0.1657)	0.4 (0.016)	32218-V5003
4.02 - 4.11 (0.1583 - 0.1618)	0.5 (0.020)	32218-V5004
3.92 - 4.01 (0.1543 - 0.1579)	0.6 (0.024)	32218-V5005

*Always check with the Parts Department for the latest parts information.

Special Service Tools

NEMT0001

The actual shapes of Kent-Moore tools may differ from those of special service tools illustrated here.

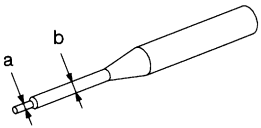
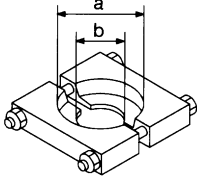
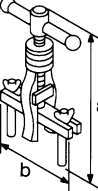
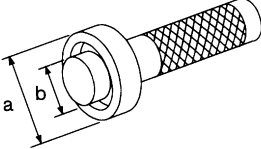
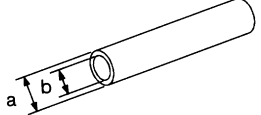
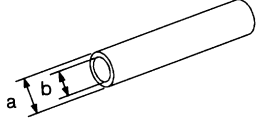
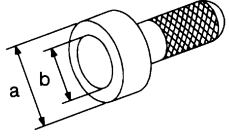
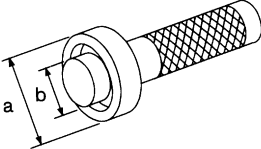
Tool number (Kent-Moore No.) Tool name	Description		
ST23540000 (J25689-A) Pin punch		Removing and installing retaining pin a: 2.3 mm (0.091 in) dia. b: 4 mm (0.16 in) dia.	GI MA EM LC
ST30031000 (J22912-01) Puller		Removing 1st & 2nd synchronizer assembly Removing counter gear rear thrust bearing Removing main drive bearing a: 90 mm (3.54 in) dia. b: 50 mm (1.97 in) dia.	EC FE
ST33290001 (J34286) Puller		Removing rear oil seal a: 250 mm (9.84 in) b: 160 mm (6.30 in)	CL MT AT
ST33230000 (—) Drift		Removing mainshaft and counter gear a: 51 mm (2.01 in) dia. b: 28.5 mm (1.122 in) dia.	TF PD AX
ST22350000 (J25678-01) Drift		Removing counter gear front bearing (Use with KV38100300) a: 34 mm (1.34 in) dia. b: 28 mm (1.10 in) dia.	SU BR
KV38100300 (J25523) Drift		Removing counter gear front bearing (Use with ST22350000) Installing counter gear rear bearing a: 54 mm (2.13 in) dia. b: 32 mm (1.26 in) dia.	ST RS
ST30720000 1 (J34286) 2 (J34331) Drift		1 Removing mainshaft front bearing 2 Installing mainshaft front bearing a: 77 mm (3.03 in) dia. b: 55.5 mm (2.185 in) dia.	BT HA
ST33210000 1 (J25523) 2 (J25803-01) Drift		1 Installing counter gear front bearing 2 Installing front cover oil seal a: 44 mm (1.73 in) dia. b: 24.5 mm (0.965 in) dia.	SC EL IDX

PREPARATION

FS5R30A

Special Service Tools (Cont'd)

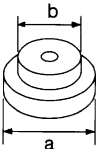
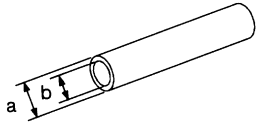
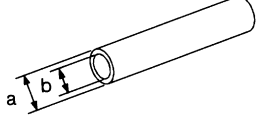
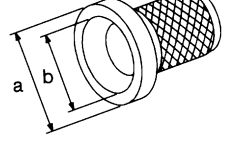
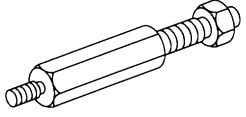
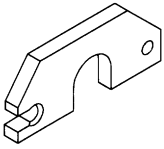
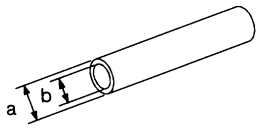
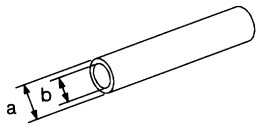
Tool number (Kent-Moore No.) Tool name	Description
ST30613000 (J25742-3) Drift	 <p>Installing main drive gear bearing a: 72 mm (2.83 in) dia. b: 48 mm (1.89 in) dia.</p>
NT073	
ST37750000 1 (J34286) 2 (J34332) 3 (J34334) 4 (J25679-01) Drift	 <p>1 Removing counter gear rear bearing 2 Installing OD gear bushing 2 Removing and installing mainshaft rear bearing (4WD model) 2 Installing reverse cone 3 Installing reverse counter gear 4 Installing counter gear rear end bearing a: 40 mm (1.57 in) dia. b: 31 mm (1.22 in) dia.</p>
NT065	
ST22452000 (J34337) Drift	 <p>Installing reverse hub Installing mainshaft rear bearing (2WD model) a: 45 mm (1.77 in) dia. b: 36 mm (1.42 in) dia.</p>
NT065	
ST33400001 (J26082) Drift	 <p>Installing rear oil seal a: 60 mm (2.36 in) dia. b: 47 mm (1.85 in) dia.</p>
NT086	
(J26349-3) Puller leg	 <p>Installing mainshaft and counter gear (Use with J34328)</p>
NT078	
(J34328) Puller	 <p>Installing mainshaft and counter gear (Use with J26349-3)</p>
NT079	
(J26092) Drift	 <p>Installing sub-gear snap ring a: 44.5 mm (1.752 in) dia. b: 38.5 mm (1.516 in) dia.</p>
NT065	
(J34342) Drift	 <p>Installing OD main gear Installing reverse gear bushing a: 44.5 mm (1.752 in) dia. b: 40.5 mm (1.594 in) dia.</p>
NT065	

PREPARATION

FS5R30A

Special Service Tools (Cont'd)

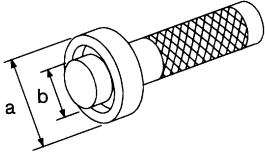
Tool number (Kent-Moore No.) Tool name	Description	GI
ST33220000 (J25804-01) Drift	 <p data-bbox="948 279 1273 359">Installing mainshaft rear bearing a: 37 mm (1.46 in) dia. b: 22 mm (0.87 in) dia.</p> <p data-bbox="412 457 472 474">NT084</p>	MA EM

Commercial Service Tool

NEMT0002

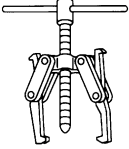
Tool name	Description	LC
Puller	 <p data-bbox="948 615 1430 722">Removing counter gear rear end bearing Removing mainshaft rear bearing (2WD model) Removing reverse synchronizer hub Removing reverse counter gear</p> <p data-bbox="412 785 472 802">NT077</p>	EC FE CL

MT

AT

TF

PD

AX

SU

BR

ST

RS

BT

HA

SC

EL

IDX

NOISE, VIBRATION AND HARSHNESS (NVH) TROUBLESHOOTING

NEMT0023

FS5R30A

NVH Troubleshooting Chart

NVH Troubleshooting Chart

NEMT0023S01

Use the chart below to help you find the cause of the problem. The numbers indicate the order of the inspection. If necessary, repair or replace these parts.

MANUAL TRANSMISSION

NEMT0023S0101

Reference page		MA-37 "Checking M/T Oil".											
SUSPECTED PARTS (Possible cause)		OIL (Level low)	OIL (Wrong)	OIL (Level too high)	GASKET (Damaged)	OIL SEAL (Worn or damaged)	O-RING (Worn or damaged)	CHECK PLUG RETURN SPRING AND CHECK BALL (Worn or damaged)	SHIFT FORK (Worn)	GEAR (Worn or damaged)	BEARING (Worn or damaged)	BAULK RING (Worn or damaged)	INSERT SPRING (Damaged)
Symptom	Noise	1	2							3	3		
	Oil leakage		3	1	2	2	2						
	Hard to shift or will not shift		1	1								2	2
	Jumps out of gear							1	2	2			

DESCRIPTION

NEMT0005

FS5R30A

Cross-sectional View — 2WD Model

Cross-sectional View — 2WD Model

NEMT0005S01

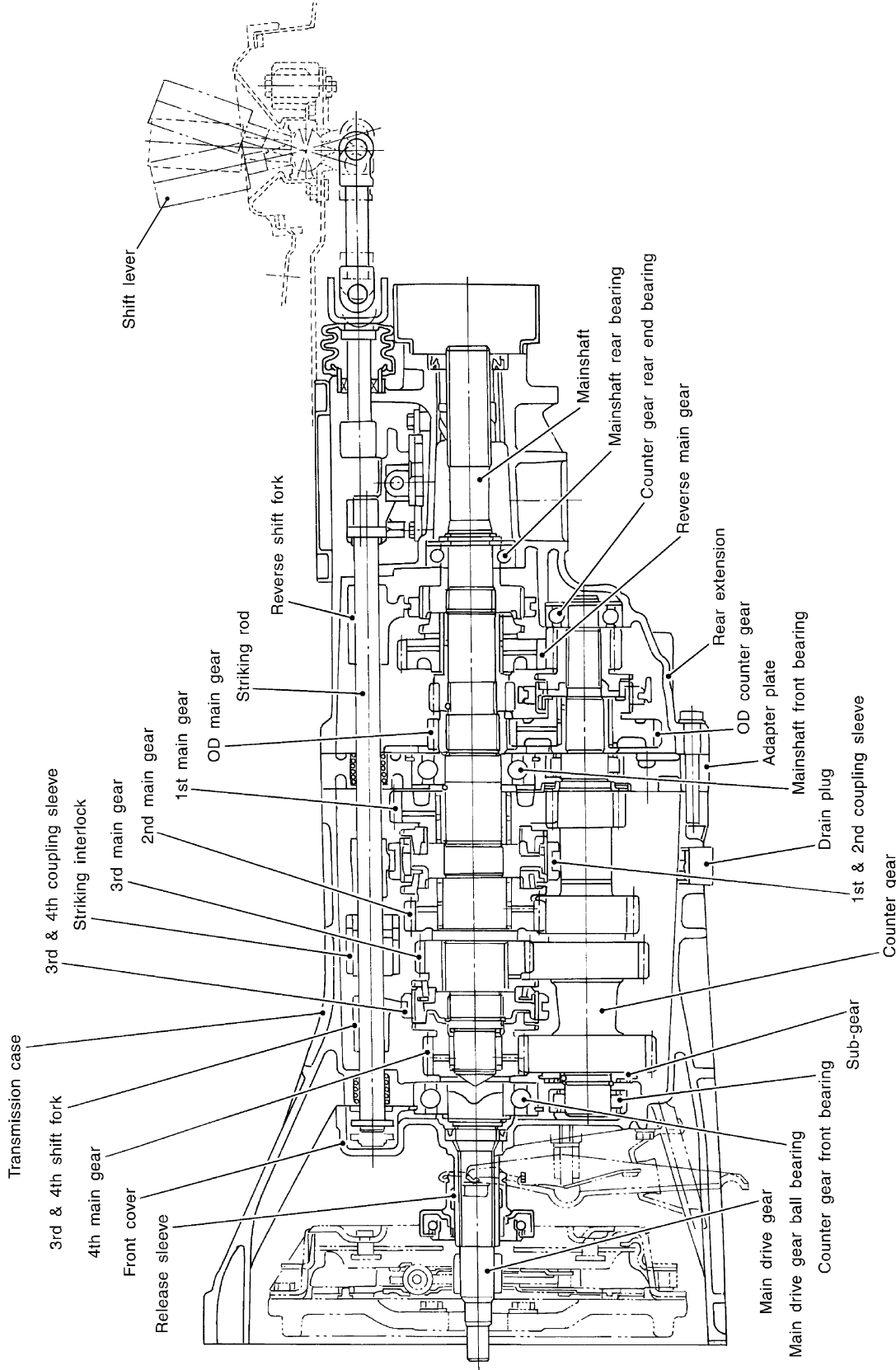

GI

MA

EM

LC

EC

FE

CL

MT

AT

TF

PD

AX

SU

BR

ST

RS

BT

HA

SC

EL

IDX

WMT041

DESCRIPTION

FS5R30A

Cross-sectional View — 4WD Model

Cross-sectional View — 4WD Model

NEMT0005S02

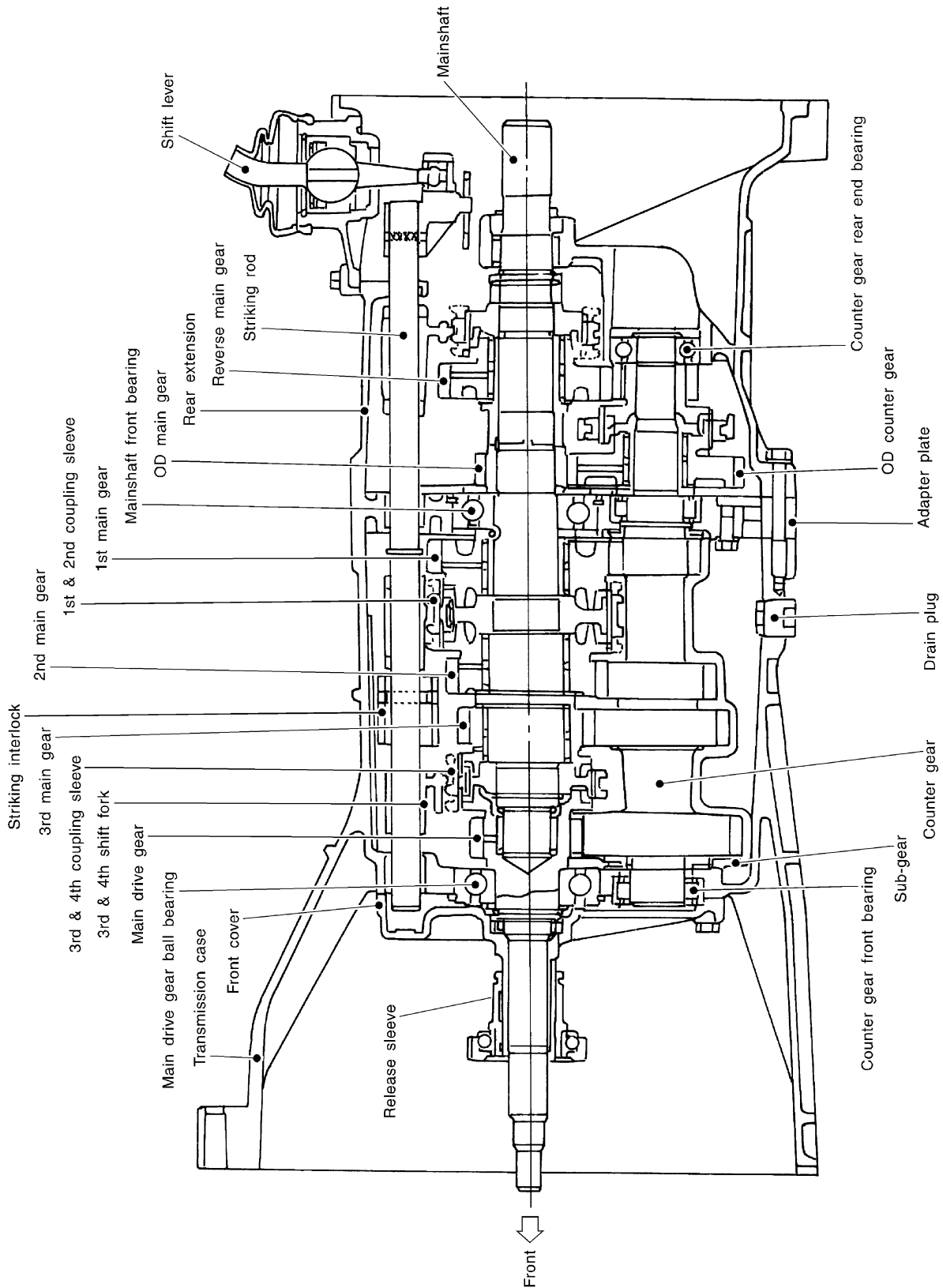

SMT320D

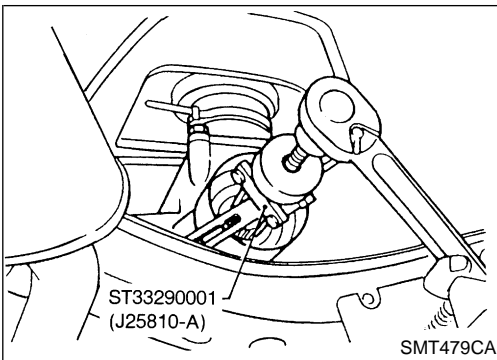

Replacing Rear Oil Seal — 2WD Model
REMOVAL

NEMT0003

NEMT0003S01

1. Remove the propeller shaft. Refer to **PD-9**, "Removal and Installation".
2. Remove rear oil seal using Tool.
 - **Always replace with a new seal once it has been removed.**

GI
 MA
 EM

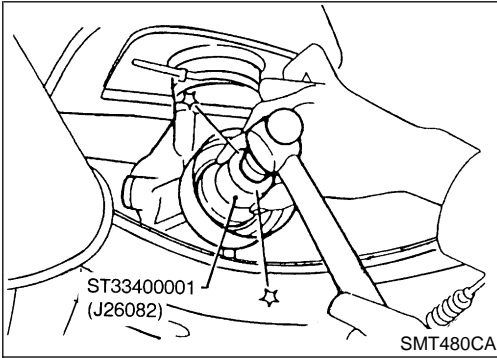

INSTALLATION

NEMT0003S02

1. Install new oil seal until it stops.
 - **Apply multi-purpose grease to seal lip of oil seal before installing.**
2. Install any part removed.

LC
 EC
 FE
 CL

MT

AT
 TF

PD
 AX

SU
 BR

ST
 RS

BT
 HA

SC
 EL

IDX

Position Switch Check

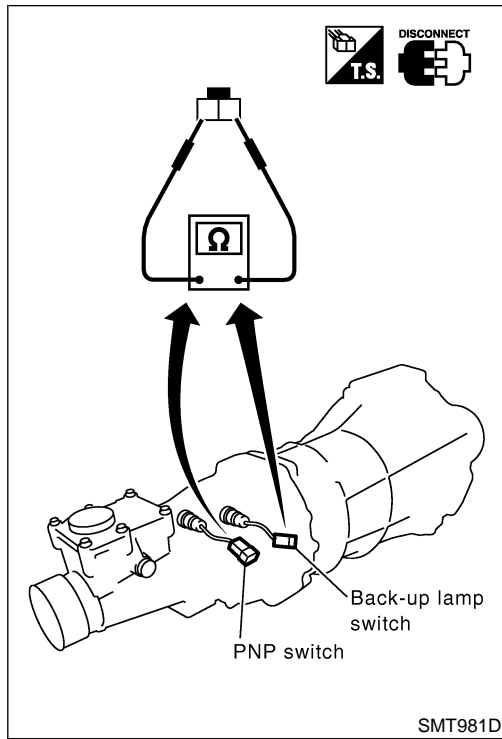

Position Switch Check

NEMT0004

Switch	Gear position	Continuity
Back-up lamp switch	Reverse	Yes
	Except reverse	No
Park/neutral position (PNP) switch	Neutral	Yes
	Except neutral	No

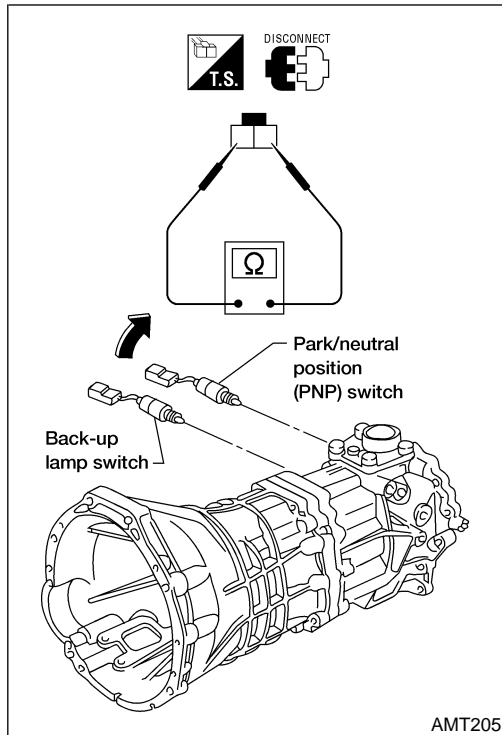

Removal

NEMT0006S01

CAUTION:

When removing the M/T assembly from engine, first remove the crankshaft position sensor (OBD) from the M/T assembly. Be careful not to damage sensor edge.

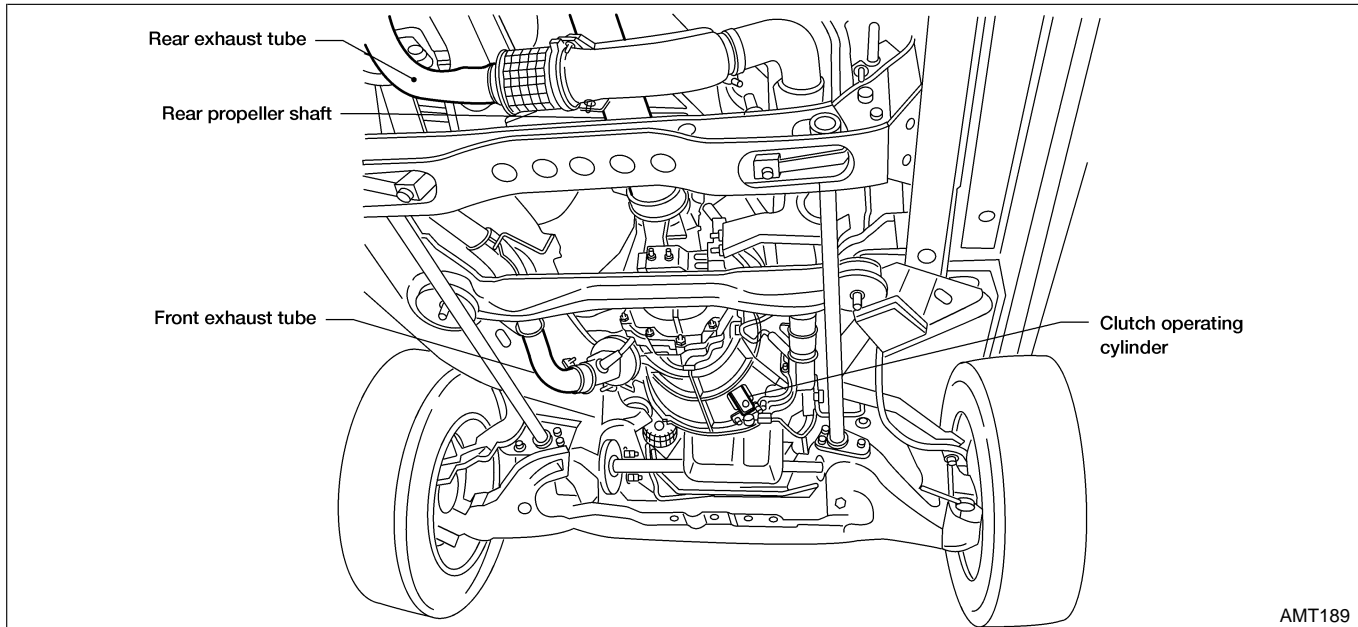

AMT189

GI
MA
EM
LC
EC
FE
CL
MT

2WD MODEL

NEMT0006S0101

1. Remove battery negative terminal.
2. Remove shift lever with control housing from transmission.
3. Remove crankshaft position sensor (OBD) from upper side of transmission case.
4. Remove clutch operating cylinder from transmission. Tighten clutch operating cylinder to the specified torque. Refer to **CL-5**, "CLUTCH SYSTEM".
5. Disconnect vehicle speed sensor, back-up lamp switch, heated oxygen sensor (rear) and park/neutral position (PNP) switch harness connectors.
6. Remove starter motor from transmission.
🔧 : 41 - 52 N·m (4.2 - 5.3 kg·m, 30 - 38 ft·lb)
7. Remove propeller shaft. Refer to **PD-9**, "Removal and Installation".
 - Insert plug into rear oil seal after removing propeller shaft.
 - Be careful not to damage spline, sleeve yoke and rear oil seal when removing propeller shaft.
8. Remove gussets from transmission or engine.
9. Remove exhaust tube mounting bracket from transmission. Refer to **FE-8**, "EXHAUST SYSTEM".
10. Support manual transmission with a jack.
11. Remove rear mounting member. Tighten rear mounting member to the specified torque. Refer to **EM-112**, "Removal and Installation".
12. Lower manual transmission as much as possible.

TF
PD
AX
SU
BR
ST
RS
BT
HA
SC

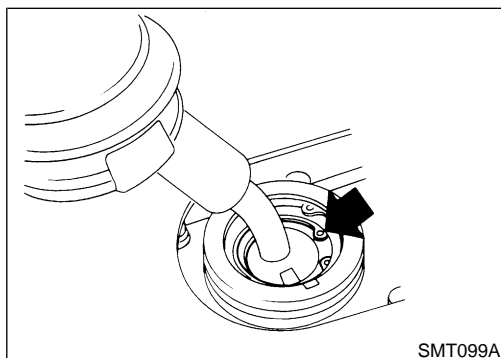

SMT099A

WARNING:

Support manual transmission together with transfer, while removing it.

EL

Removal (Cont'd)

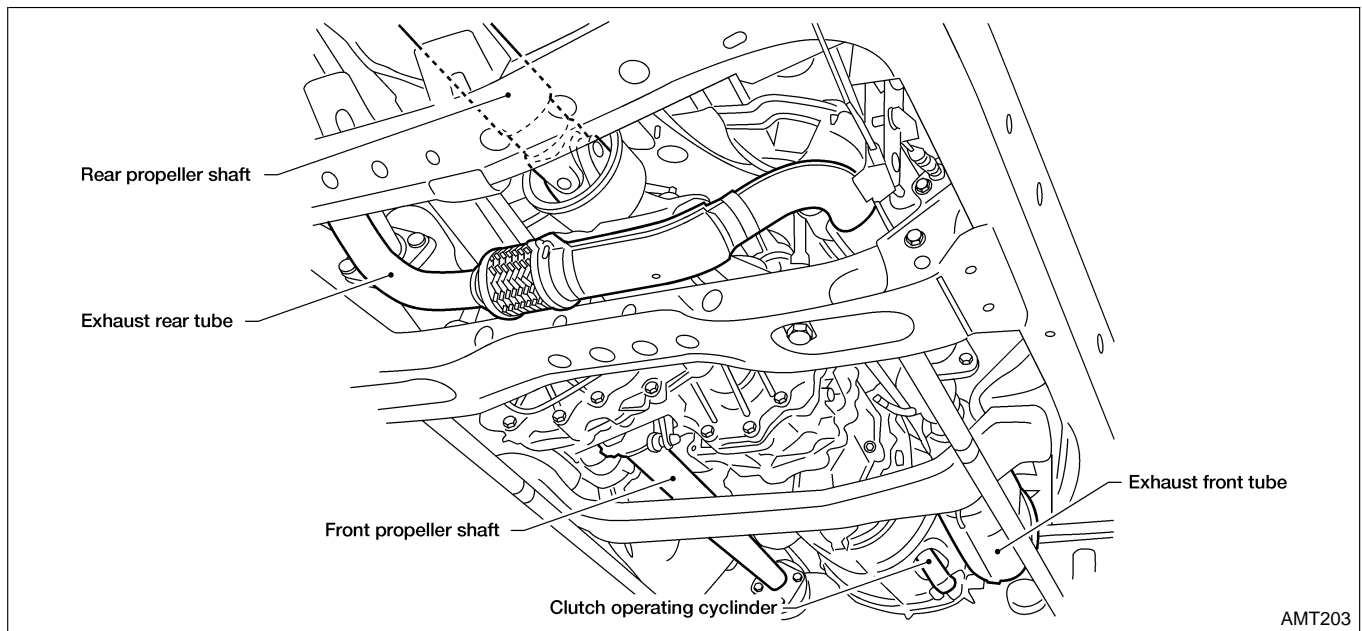

AMT203

4WD MODEL

NEMT0006S0102

1. Disconnect the battery negative terminal.
2. Remove shift lever from transmission and control lever from transfer.
3. Remove clutch operating cylinder from transmission. Tighten clutch operating cylinder to the specified torque. Refer to **CL-5**, "CLUTCH SYSTEM".
4. Disconnect the vehicle speed sensor, back-up lamp switch, heated oxygen sensor (rear) and Park/neutral position (PNP) switch harness connectors.
5. Remove the starter motor from transmission.
 - 🔧 : 41 - 52 N·m (4.2 - 5.3 kg·m, 30 - 38 ft·lb)
6. Remove front and rear propeller shafts. Refer to **PD-9**, "PROPELLER SHAFT".
 - Insert plug into rear oil seal after removing propeller shaft.
 - Be careful not to damage spline, sleeve yoke and rear oil seal when removing propeller shaft.
7. Remove exhaust tube mounting bracket from transmission. Refer to **FE-8**, "EXHAUST SYSTEM".
8. Remove front exhaust tubes and center pipe.
9. Remove the torsion bars and mounts. Refer to **SU-14**, "Removal".
10. Remove the rear torsion bar cross member.
11. Remove the gussets from the transmission or engine.
12. Support the manual transmission with a jack.
13. Remove rear mounting member. Tighten rear mounting member to the specified torque. Refer to **EM-112**, "Engine Mounting".
14. Lower manual transmission as much as possible.

WARNING:

Support manual transmission together with transfer while removing it.

REMOVAL AND INSTALLATION

FS5R30A

Removal (Cont'd)

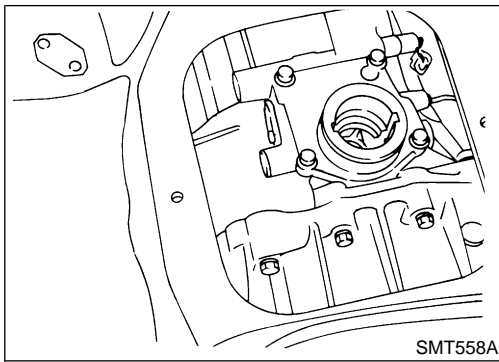

15. Remove crankshaft position sensor (OBD) from upper side of transmission case.

16. Remove transmission bolts.

WARNING:

Support manual transmission together with transfer while removing it.

GI
MA
EM
LC
EC
FE
CL

MT

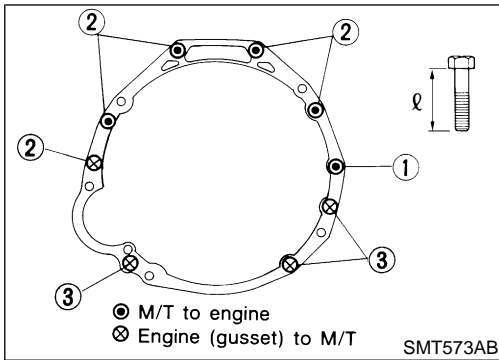

Installation

NEMT0006S02

- Tighten the bolts securing the transmission to the specified torques in the chart below.

Bolt No.	Tightening torque N-m (kg-m, ft-lb)	ℓ mm (in)
1	39 - 49 (4.0 - 5.0, 29 - 36)	65 (2.56)
2	39 - 49 (4.0 - 5.0, 29 - 36)	58 (2.28)
3	29 - 39 (3.0 - 4.0, 22 - 29)	25 (0.98)
4 (Gusset to engine)	29 - 39 (3.0 - 4.0, 22 - 29)	20 (0.79)

AT
TF
PD
AX

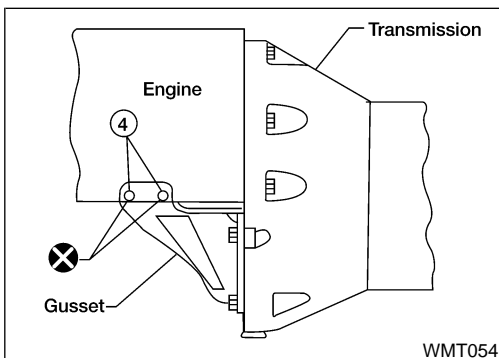

- Adjust the torsion bars for the correct vehicle height. Refer to **SU-15**, "INSTALLATION AND ADJUSTMENT".

SU
BR
ST
RS
BT
HA
SC
EL
IDX

OVERHAUL

FS5R30A

Gear Components (Cont'd)

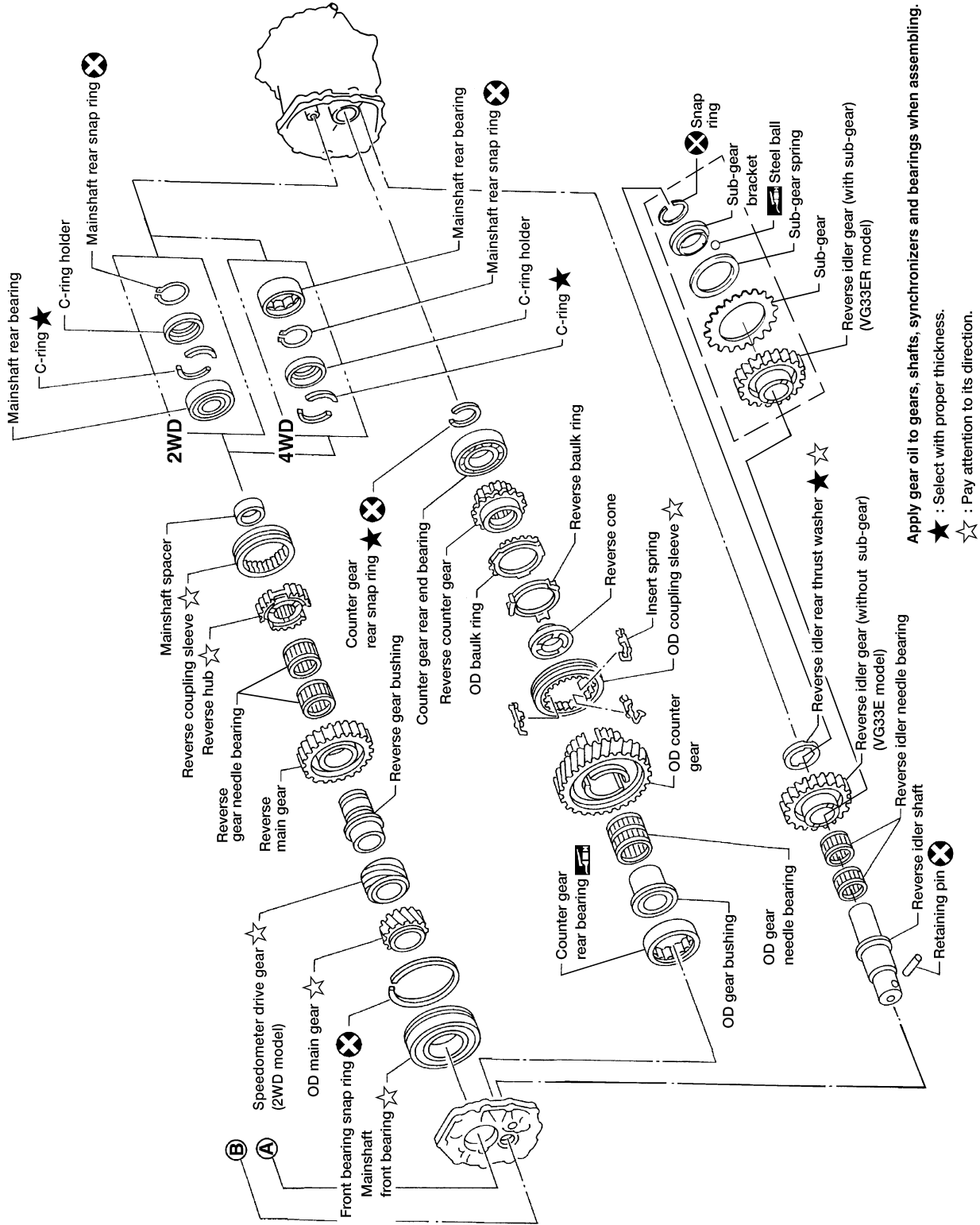

Apply gear oil to gears, shafts, synchronizers and bearings when assembling.

★ : Select with proper thickness.

☆ : Pay attention to its direction.

SEC. 322

MT-46

WMT048

Shift Control Components (2/4WD models)

NEMT0007S03

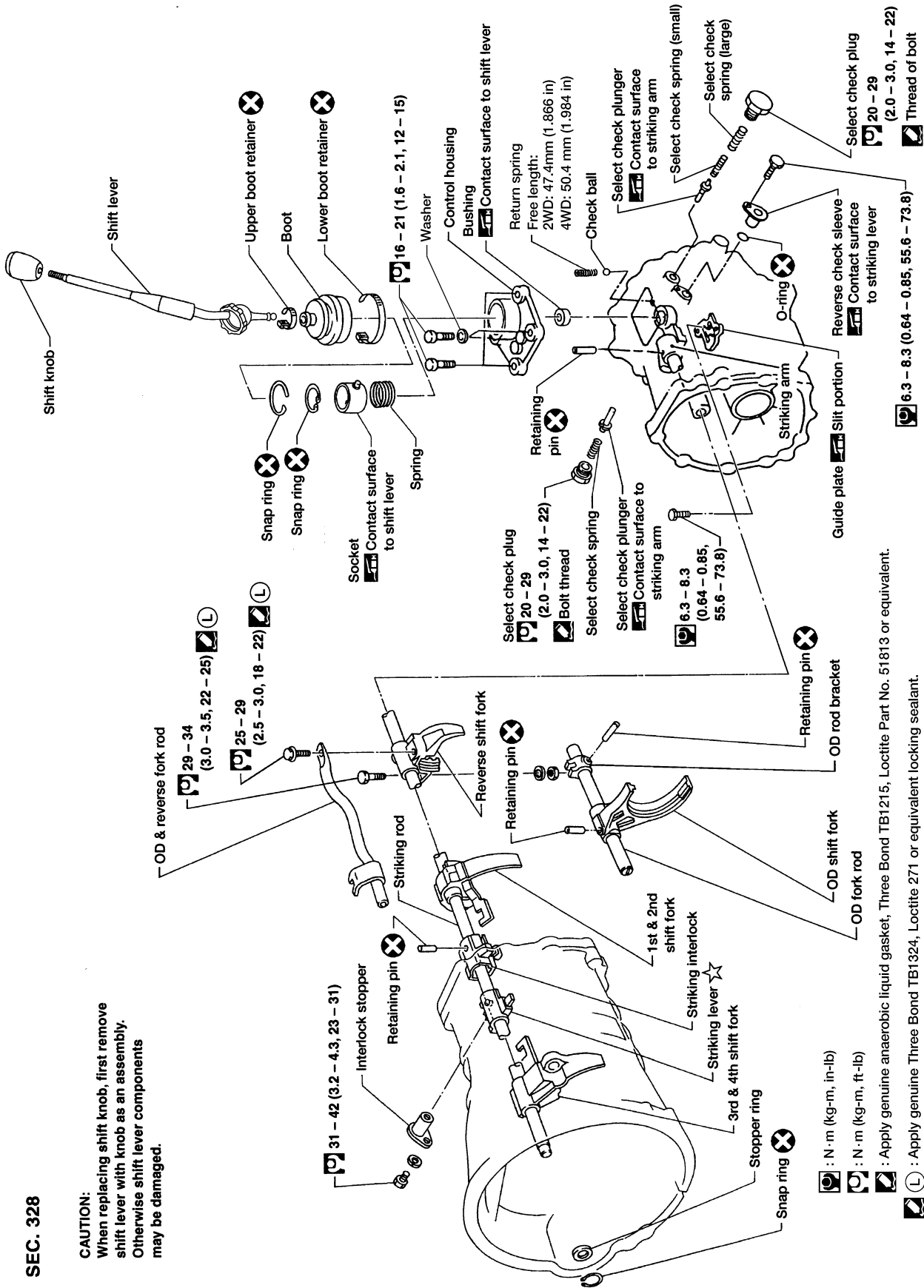

SEC. 328

CAUTION:

When replacing shift knob, first remove shift lever with knob as an assembly. Otherwise shift lever components may be damaged.

⊗ : N·m (kg·m, in·lb)

⊙ : N·m (kg·m, ft·lb)

⊠ : Apply genuine anaerobic liquid gasket, Three Bond TB1215, Loctite Part No. 51813 or equivalent.

⊡ : Apply genuine Three Bond TB1324, Loctite 271 or equivalent locking sealant.

Ⓛ : Pay attention to its direction.

☆

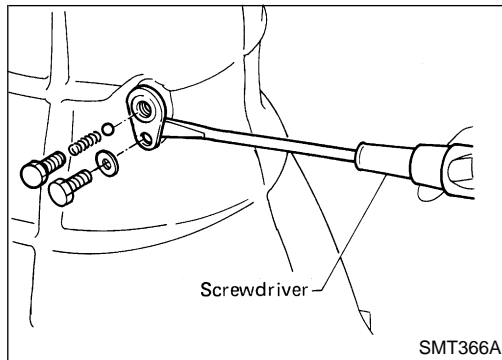

Case Components

DISASSEMBLY

NEMT0008

1. Remove check ball plug, check spring and check ball. Then remove interlock stopper.
 - If interlock assembly is removed as a unit, the check ball can fall into transmission case.
 - Be careful not to lose check ball.

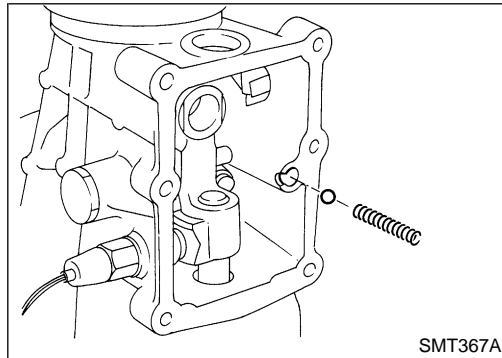

2. Remove control housing, return spring and check ball.
 - Be careful not to lose check ball.

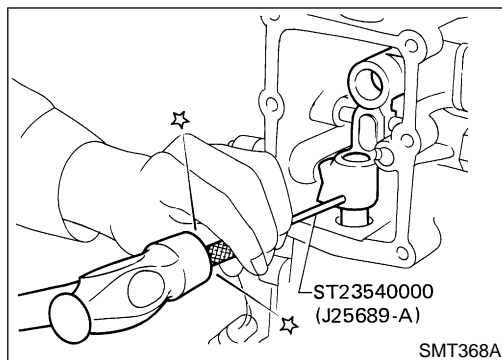

3. Drive out retaining pin from striking arm.

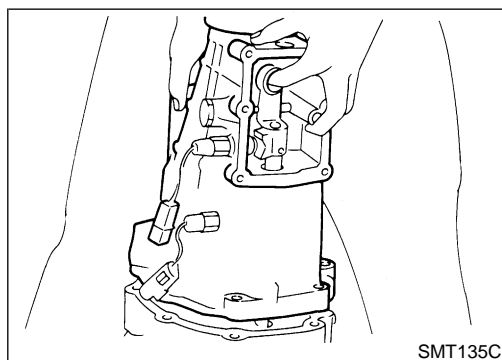

4. Remove rear extension (or OD gear case) together with striking arm by tapping lightly.

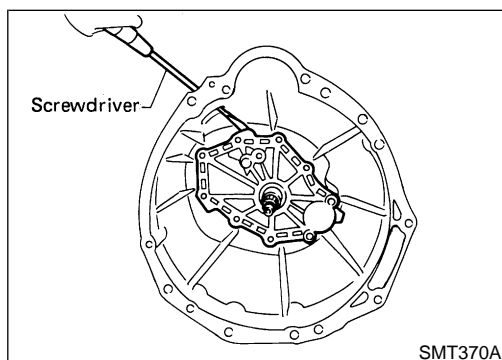

5. Remove front cover and gasket.

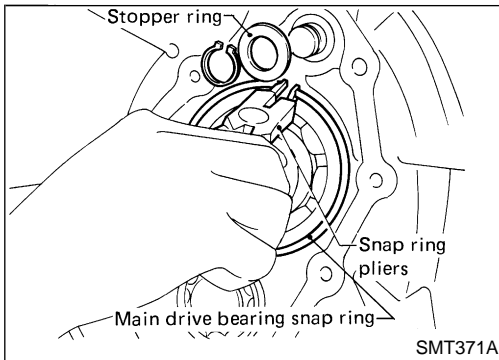

6. Remove stopper ring and main drive bearing snap ring.

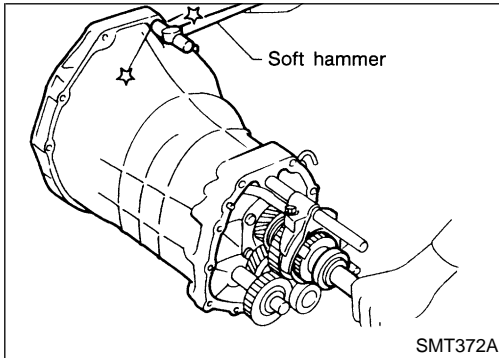

7. Remove transmission case by tapping lightly.

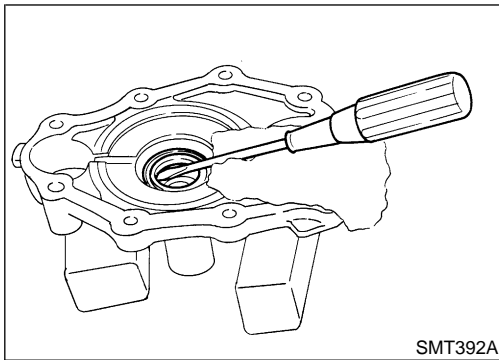

8. Remove front cover oil seal.

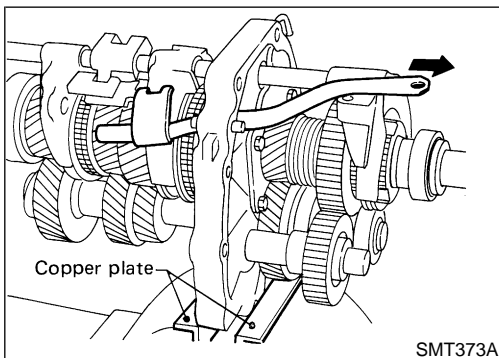

Shift Control Components DISASSEMBLY

1. Mount adapter plate on vise.
2. Remove OD & reverse fork rod.

NEMT0009

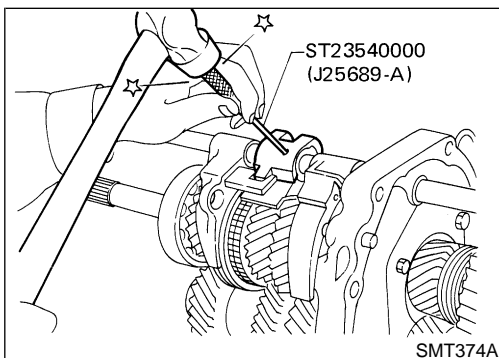

3. Drive out retaining pin from striking lever.
4. While pulling out striking rod, remove striking lever and striking interlock. Then remove 1st and 2nd, 3rd and 4th, and reverse shift forks.

GI

MA

EM

LC

EC

FE

CL

MT

AT

TF

PD

AX

SU

BR

ST

RS

BT

HA

SC

EL

IDX

Shift Control Components (Cont'd)

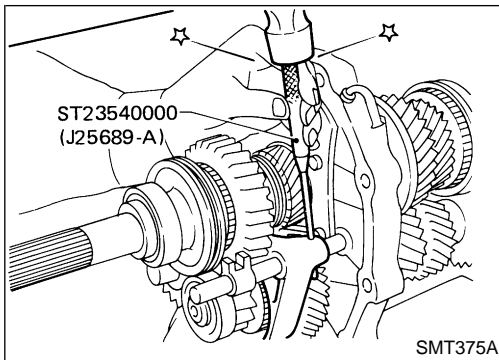

5. Drive out retaining pin from OD shift fork.
6. Pull out OD fork rod and then remove OD shift fork.

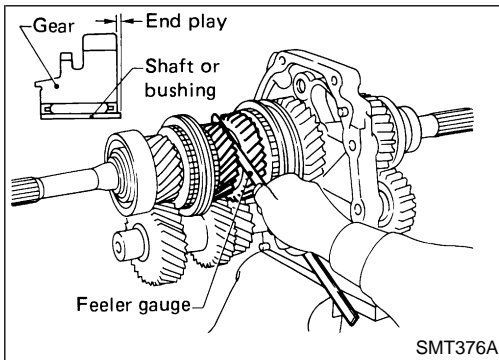

Gear Components

DISASSEMBLY

NEMT0010

1. Before removing gears and shafts, measure each gear end play. Refer to "Gear End Play", MT-67.
 - If not within specification, disassemble and check contact surface of gear to hub, washer, bushing, needle bearing and shaft.

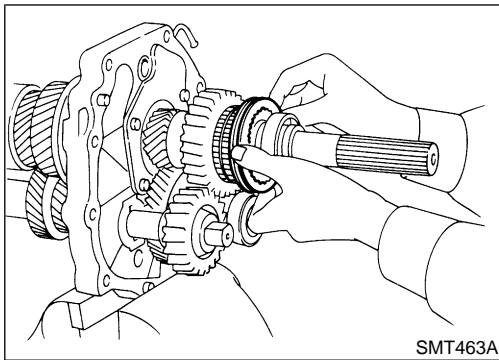

2. Remove rear side components on mainshaft and counter gear.
 - a. Remove reverse coupling sleeve.

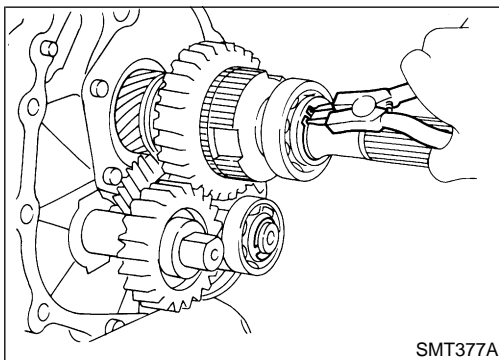

- b. Remove mainshaft rear snap ring and counter gear rear snap ring.
 - c. Remove C-ring holder and mainshaft C-rings from mainshaft. Use punch and hammer to remove C-rings.

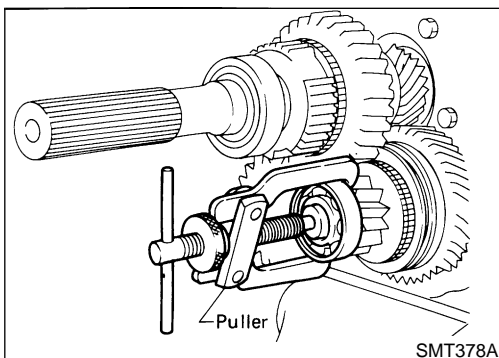

- d. Pull out counter gear rear end bearing.
 - e. Remove reverse idler gear and reverse idler thrust washers.

DISASSEMBLY

FS5R30A

Gear Components (Cont'd)

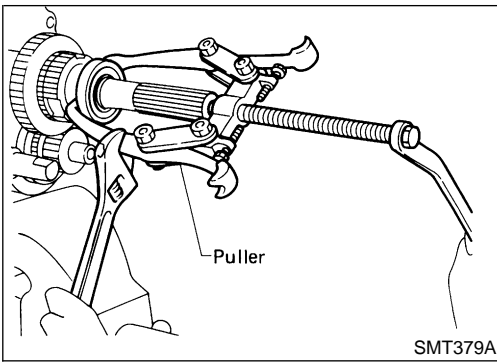

f. Pull out mainshaft rear bearing (2WD model).

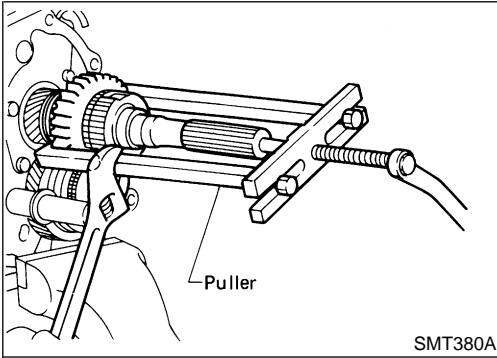

g. Pull out reverse main gear together with mainshaft spacer and reverse synchronizer hub. Then remove reverse gear needle bearings.

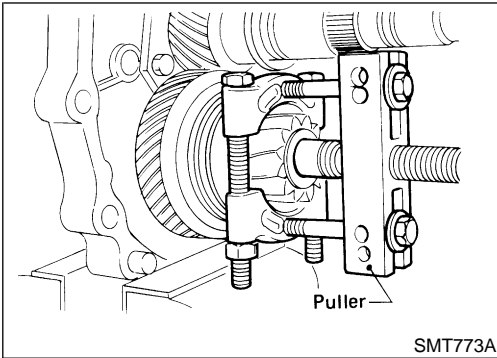

h. Pull out reverse counter gear.

i. Remove OD coupling sleeve together with OD baulk ring, reverse baulk ring and spring inserts.

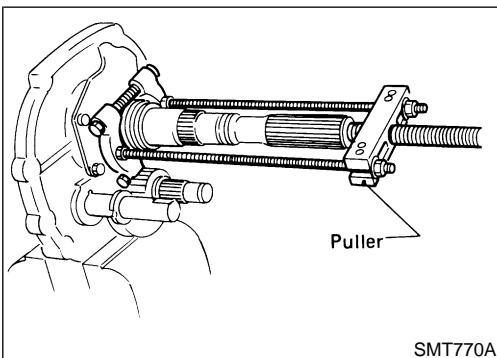

j. Pull out reverse gear bushing.

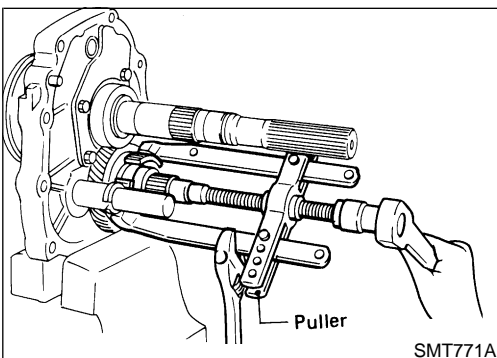

k. Pull out OD counter gear together with reverse cone.

GI

MA

EM

LC

EC

FE

CL

MT

AT

TF

PD

AX

SU

BR

ST

RS

BT

HA

SC

EL

IDX

3. Press out mainshaft and counter gear alternately.

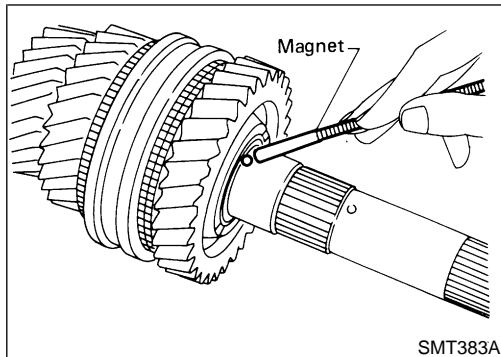
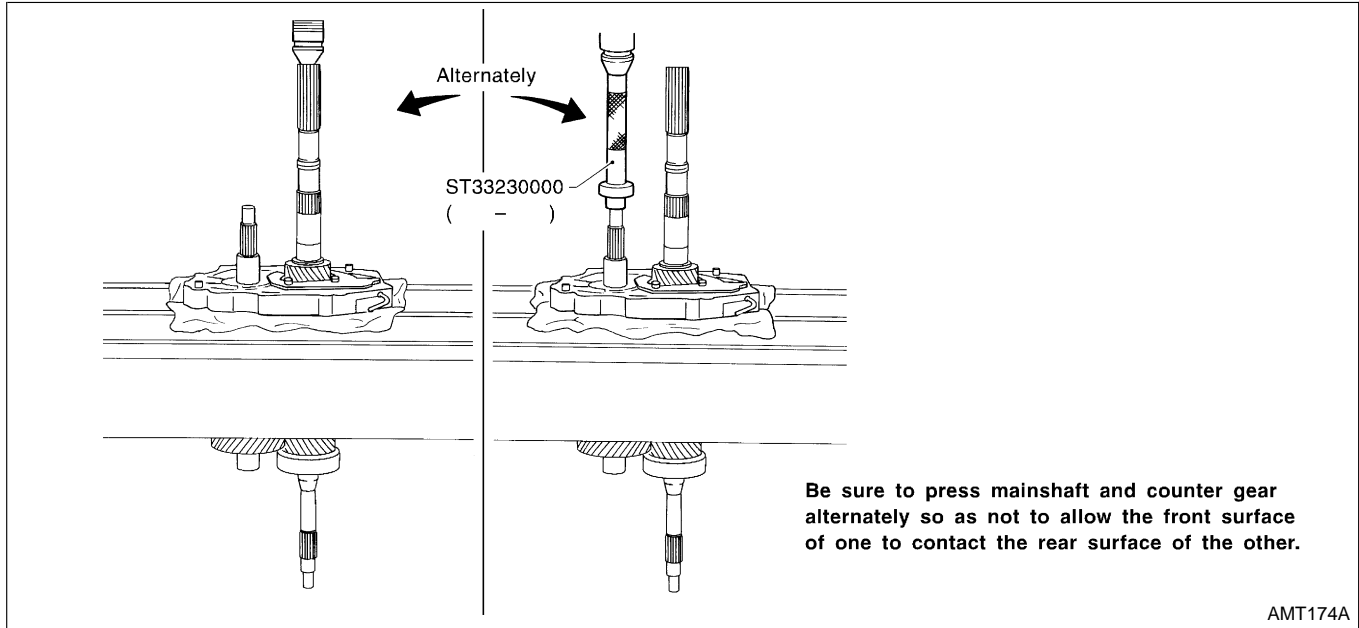

4. Remove front side components on mainshaft.
- Remove 1st gear washer and steel ball.
 - Remove 1st main gear and 1st gear needle bearing.
- Be careful not to lose steel ball.**

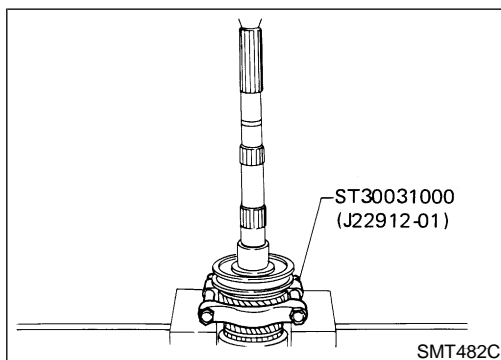

- Press out 2nd main gear together with 1st gear bushing and 1st and 2nd synchronizer assembly.
- Remove mainshaft front snap ring.

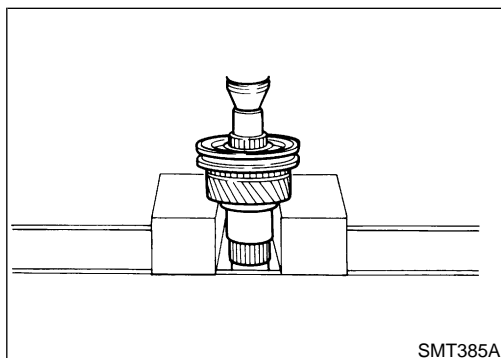

- Press out 3rd main gear together with 3rd and 4th synchronizer assembly and 3rd gear needle bearing.

DISASSEMBLY

FS5R30A

Gear Components (Cont'd)

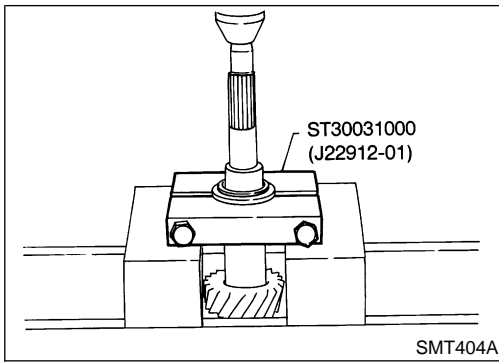

5. Remove front side components on counter gear.
 - a. Remove counter gear rear thrust bearing.

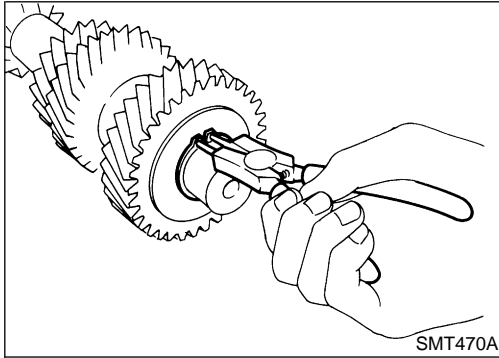

- b. Remove sub-gear components.

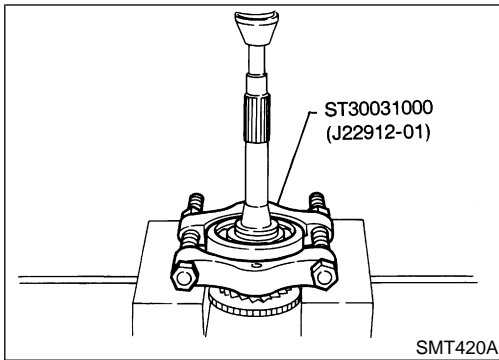

6. Remove main drive gear bearing.
 - a. Remove main drive gear snap ring.
 - b. Press out main drive gear bearing.

7. Remove bearings from case components.

<p>Counter gear front bearing in transmission case</p>	<p>Mainshaft front bearing in adapter plate</p>
<p>Mainshaft rear bearing in OD gear case</p>	<p>Counter gear rear bearing in adapter plate</p>

AMT173

GI
MA
EM
LC
EC
FE
CL
MT
AT
TF
PD
AX
SU
BR
ST
RS
BT
HA
SC
EL
IDX

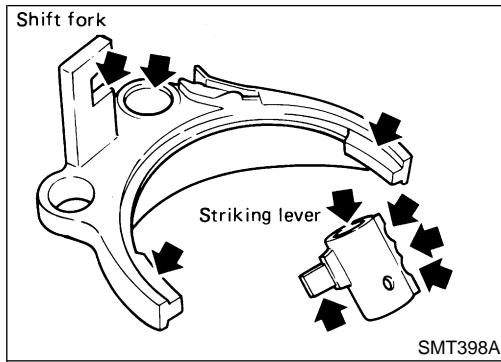

Shift Control Components

INSPECTION

- Check contact surface and sliding surface for wear, scratches, projections or other damage. NEMT0011

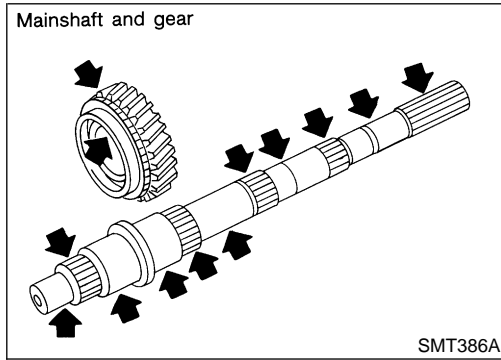

Gear Components

INSPECTION

Gears and Shafts

- Check shafts for cracks, wear or bending. NEMT0012
- Check gears for excessive wear, chips or cracks. NEMT0012S01

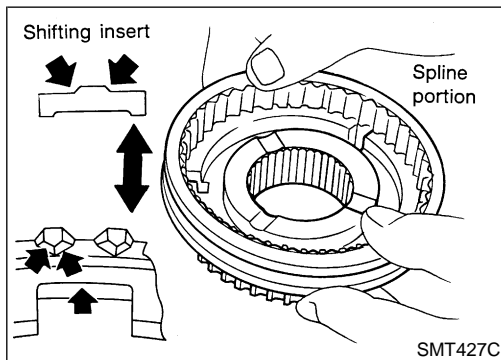
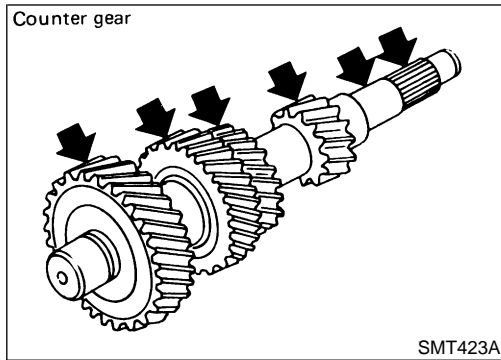

Synchronizers

- Check spline portion of coupling sleeves, hubs, and gears for wear or cracks. NEMT0012S02
- Check baulk rings for cracks or deformation.
- Check shifting inserts for wear or deformation.
- Check insert springs for deformation.

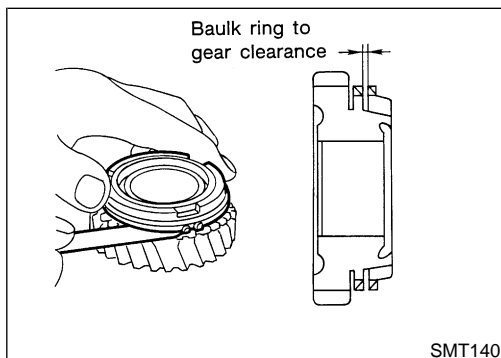

- Measure wear of main drive, 1st (VG33E model) and OD baulk rings. Refer to "Clearance Between Baulk Ring and Gear", MT-67.
- If the clearance is smaller than the wear limit, replace baulk ring.

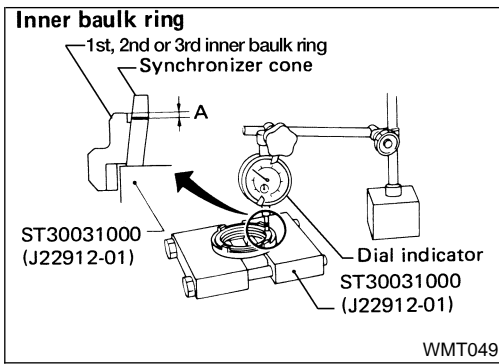

- Measure wear of 1st, 2nd and 3rd double baulk rings.
1st, 2nd and 3rd double baulk rings: VG33ER model.
2nd and 3rd double baulk rings: VG33E model.
- a) Place baulk rings in position on synchronizer cone.
- b) While holding baulk rings against synchronizer cone as far as it will go, measure dimensions "A" and "B".

Standard:

A 0.7 - 0.9 mm (0.028 - 0.035 in)

B 0.6 - 1.1 mm (0.024 - 0.043 in)

Wear limit:

0.2 mm (0.008 in)

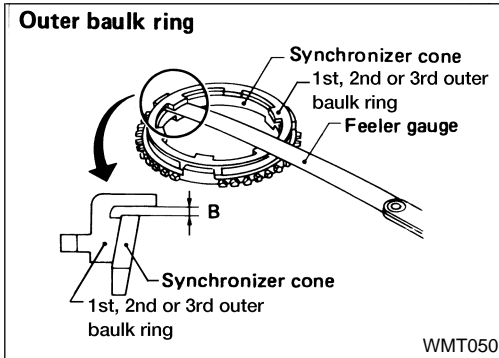

- If dimension "A" or "B" is smaller than the wear limit, replace outer baulk ring, inner baulk ring and synchronizer cone as a set.

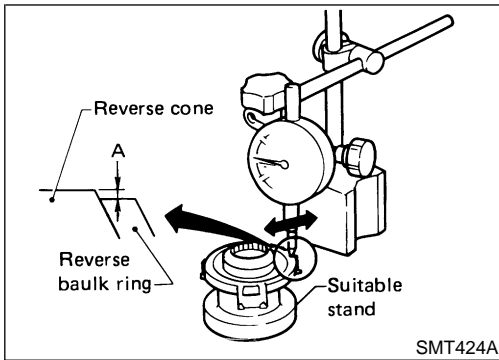

- Measure wear of reverse baulk ring.
- a) Place baulk ring in position on reverse cone.
- b) While holding baulk ring against reverse cone as far as it will go, measure dimension "A" with dial indicator.

Dimension "A":

Standard -0.1 to 0.35 mm (-0.0039 to 0.0138 in)

Wear limit 0.7 mm (0.028 in)

- c) If dimension "A" is larger than the wear limit, replace baulk ring.

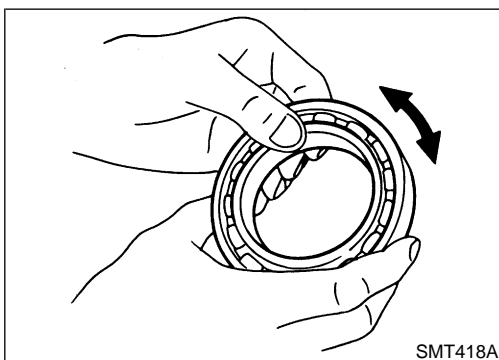

Bearings

- Make sure bearings roll freely and are free from noise, crack, pitting or wear.

GI

MA

EM

LC

EC

FE

CL

MT

AT

TF

PD

AX

SU

BR

ST

RS

BT

HA

SC

EL

IDX

Gear Components ASSEMBLY

NEMT0013

Counter gear front bearing in transmission case

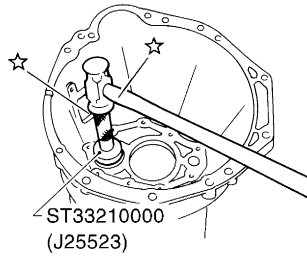

Mainshaft front bearing in adapter plate

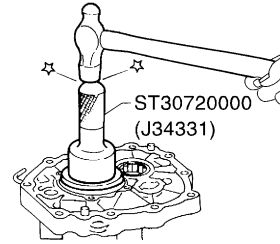

Mainshaft rear bearing in OD gear case

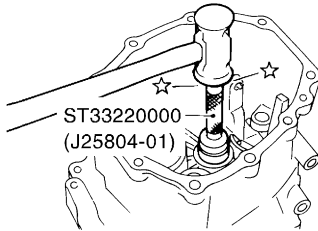

Counter gear rear bearing in adapter plate

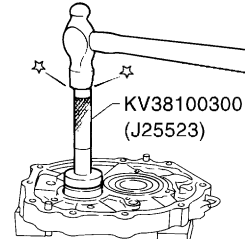

Be flush with front surface of OD gear case.

AMT172

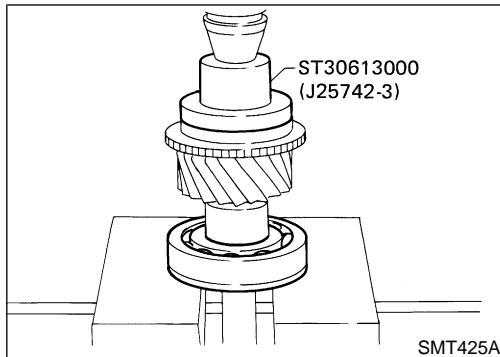

SMT425A

1. Install bearings into case components.
2. Install main drive gear bearing.
 - a. Press main drive gear bearing.

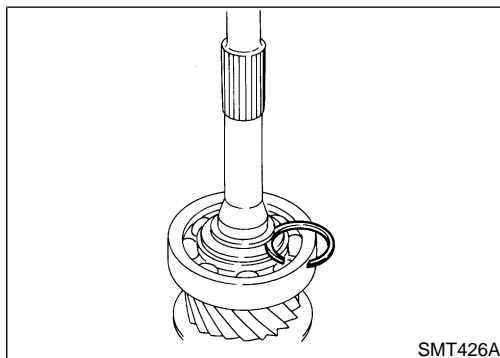

SMT426A

- b. Select proper main drive gear snap ring to minimize clearance of groove. Refer to "MAIN DRIVE GEAR SNAP RING", MT-68.

Allowable clearance of groove:

0 - 0.11 mm (0 - 0.004 in)

- c. Install selected snap ring on main drive gear.

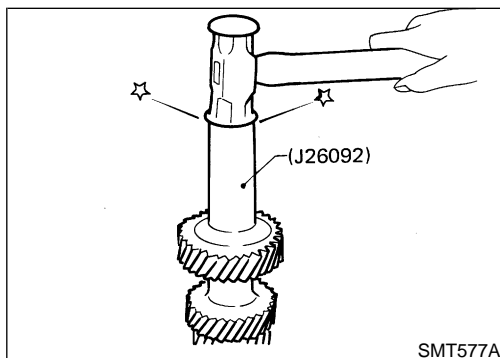

SMT577A

3. Install components on counter gear.
 - a. Install sub-gear components.
 - **When installing sub-gear snap ring, tap sub-gear snap ring into position on counter gear.**

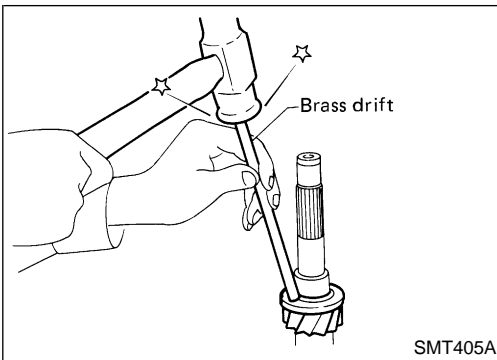

b. Install counter gear rear thrust bearing.

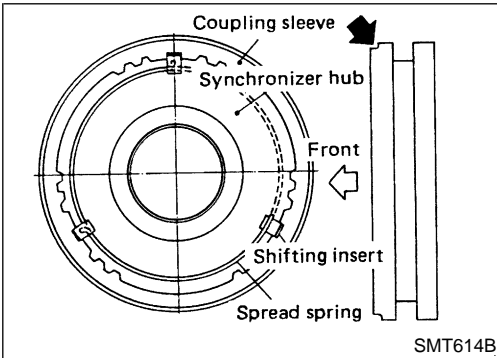

4. Install front side components on mainshaft.

a. Assemble 1st and 2nd synchronizer.

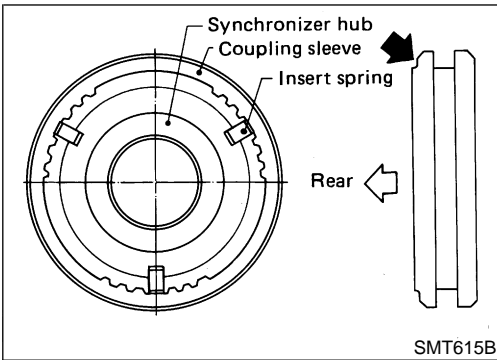

b. Assemble 3rd and 4th synchronizer.

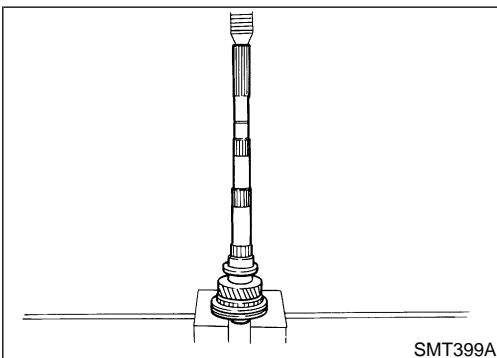

c. Press on 3rd and 4th synchronizer assembly together with 3rd main gear and 3rd gear needle bearing.

● **Pay attention to direction of synchronizer assembly.**

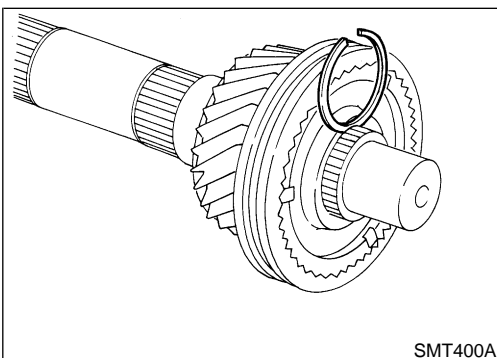

d. Select proper snap ring to minimize clearance of groove. Refer to "MAINSHAFT FRONT SNAP RING", MT-68.

Allowable clearance of groove:

0 - 0.1 mm (0 - 0.004 in)

e. Install selected snap ring on mainshaft.

GI

MA

EM

LC

EC

FE

CL

MT

AT

TF

PD

AX

SU

BR

ST

RS

BT

HA

SC

EL

IDX

Gear Components (Cont'd)

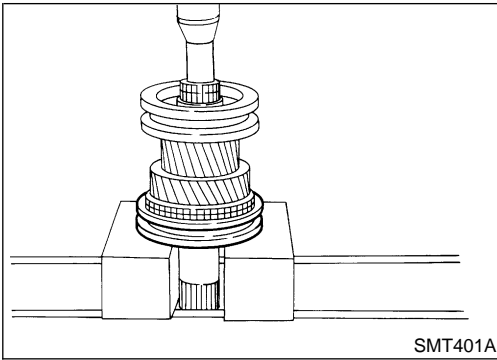

- f. Press on 1st and 2nd synchronizer assembly together with 2nd main gear and 2nd gear needle bearing.

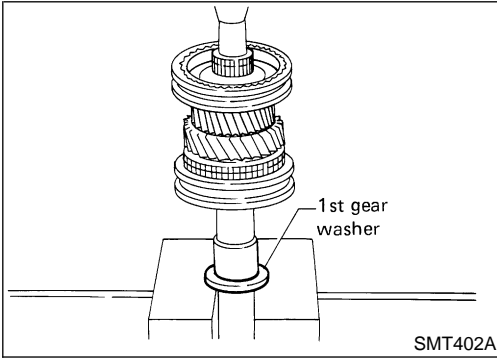

- g. Press on 1st gear bushing using 1st gear washer.
- h. Install 1st main gear and needle bearing.

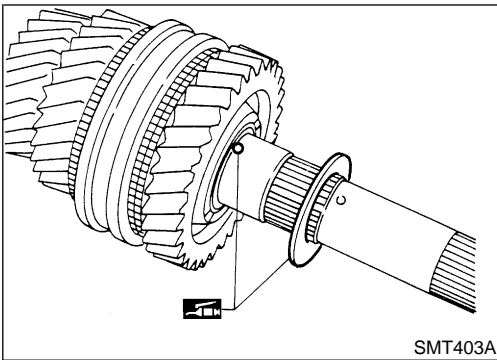

- i. Install steel ball and 1st gear washer.
- **Apply multi-purpose grease to steel ball and 1st gear washer before installing.**

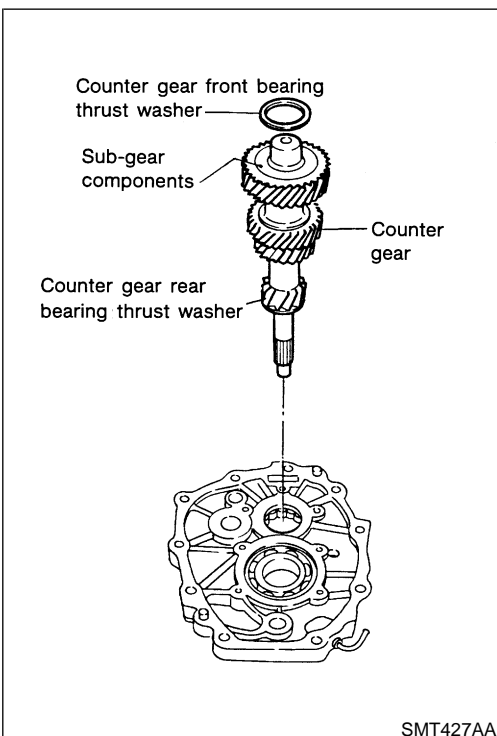

5. Select proper counter gear front bearing thrust washer when replacing transmission case, counter gear, counter gear rear thrust bearing or sub-gear components.
 - a. Install counter gear with sub-gear components, counter gear front and rear bearing thrust washer on adapter plate.
 - b. Remove counter gear front bearing thrust washer from transmission case.
 - c. Place adapter plate and counter gear assembly in transmission case (case inverted).

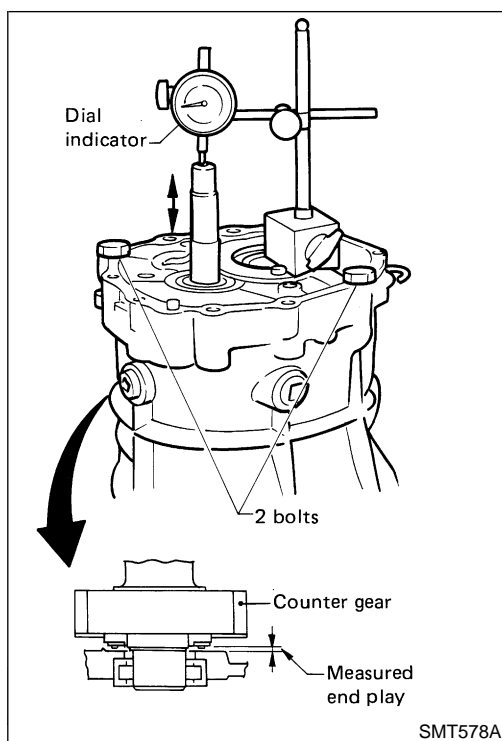

- d. Tighten adapter plate to transmission case using 2 bolts.
- e. Place dial indicator on rear end of counter gear.
- f. Move counter gear up and down and measure dial indicator deflection.
- g. Select proper thrust washer using the table as a guide. Refer to "TABLE FOR SELECTING PROPER COUNTER GEAR FRONT BEARING THRUST WASHER", MT-69.

Counter gear end play:

0.10 - 0.26 mm (0.0040 - 0.0102 in)

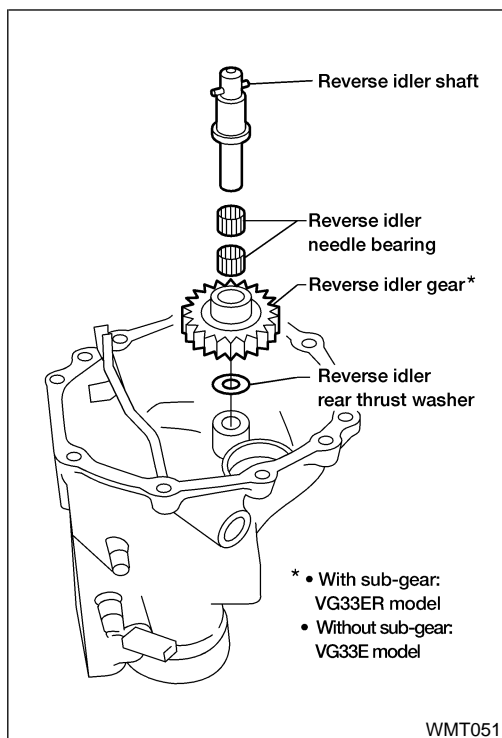

6. Select proper reverse idler rear thrust washer when replacing rear extension (or OD gear case), reverse idler gear, reverse idler shaft or reverse idler front thrust washer.
- a. Install reverse idler gear, reverse idler needle bearings, reverse idler front thrust washers and reverse idler shaft into rear extension (or OD gear case).
- **When replacing reverse idler rear thrust washer, install either A or B. Refer to "REVERSE IDLER REAR THRUST WASHER", MT-70.**

GI

MA

EM

LC

EC

FE

CL

MT

AT

TF

PD

AX

SU

BR

ST

RS

BT

HA

SC

EL

IDX

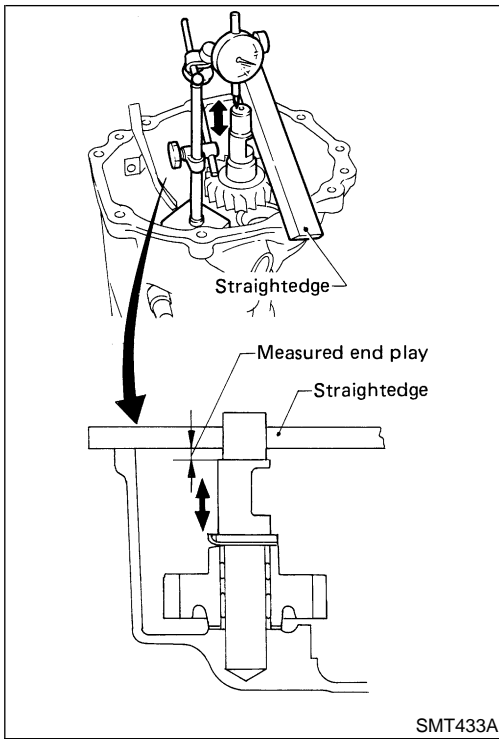

- b. Place dial indicator on front end of reverse idler shaft.
- c. Put straightedge on front surface of rear extension (or O/D gear case) as a stopper of reverse idler shaft.
- d. Move reverse idler shaft up and down and measure reverse idler gear end play.

Reverse idler gear end play:

0.30 - 0.53 mm (0.0119 - 0.0208 in)

- e. If not within specification, replace reverse idler rear thrust washer with the other (A or B) and check again.

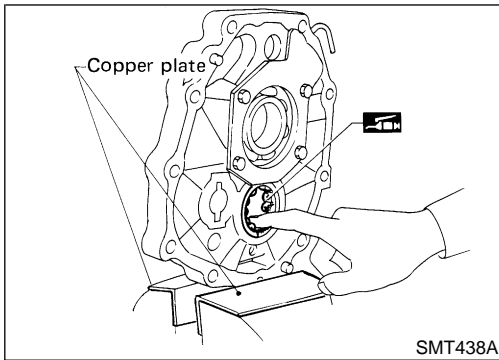

7. Install mainshaft and counter gear on adapter plate and main drive gear on mainshaft.

- a. Mount adapter plate on vise and apply multi-purpose grease to counter gear rear bearing.

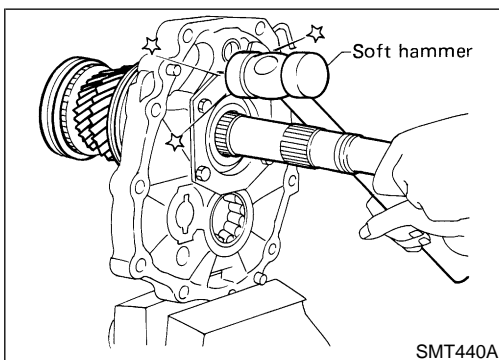

- b. Install mainshaft a little on mainshaft front bearing.
- **To allow for installation of counter gear, do not install mainshaft completely.**

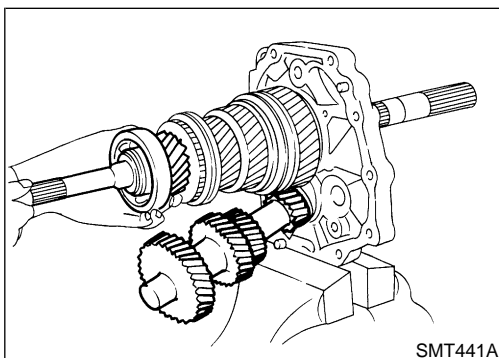

- c. Install counter gear on counter gear rear bearing and install main drive gear, pilot bearing and spacer on mainshaft.

ASSEMBLY

FS5R30A

Gear Components (Cont'd)

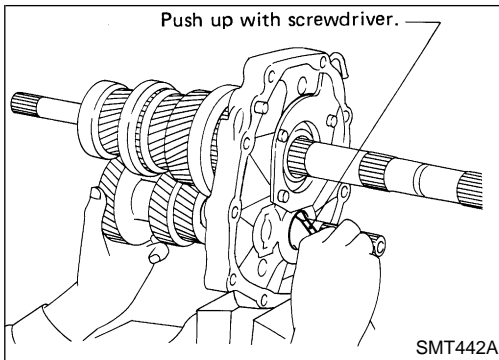

- When installing counter gear into counter gear rear bearing, push up on upper roller of counter gear rear bearing with screwdriver.

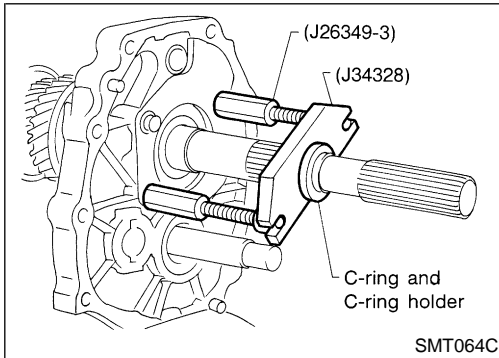

- Install Tools (J26349-3) onto adapter plate and C-ring and C-ring holder on mainshaft.
- Install Tool (J34328) on mainshaft.

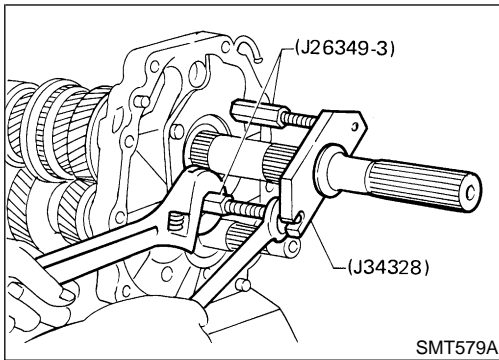

- Install mainshaft and counter gear completely by extending length of (J26349-3).

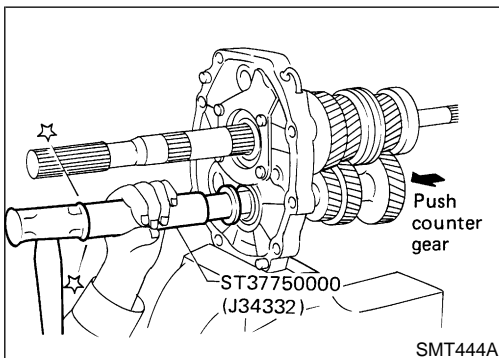

- Install rear side components on mainshaft and counter gear.
 - Install OD gear bushing while pushing on the front of counter gear.

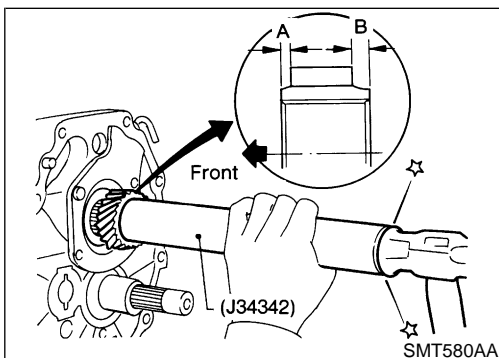

- Install OD main gear.
 - Pay attention to direction of OD main gear. (B is wider than A as shown at left.)
- Install adapter plate with gear assembly onto transmission case.
- Install OD gear needle bearing and then install OD counter gear and reverse idler shaft.

GI

MA

EM

LC

EC

FE

CL

MT

AT

TF

PD

AX

SU

BR

ST

RS

BT

HA

SC

EL

IDX

Gear Components (Cont'd)

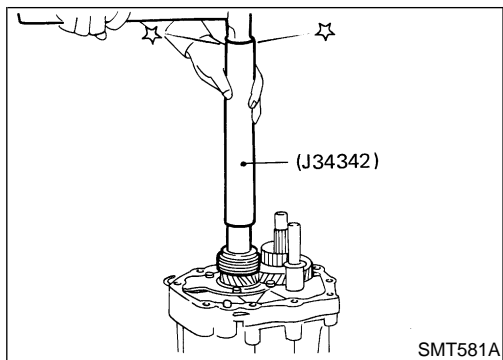

- e. Install reverse gear bushing with speedometer drive gear (2WD model).

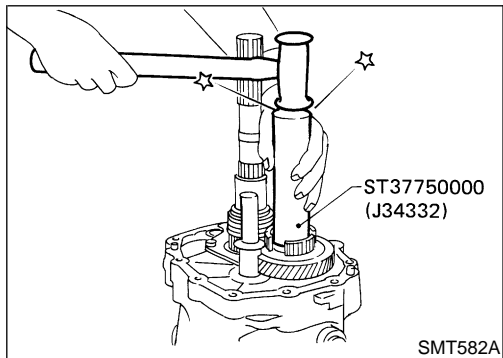

- f. Install reverse cone.

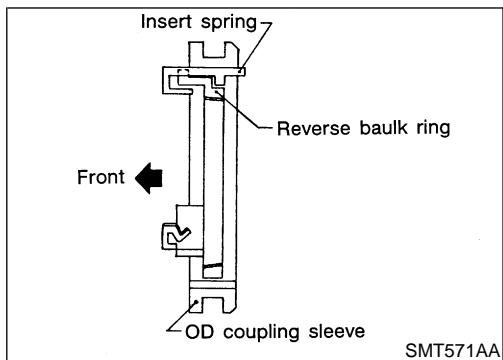

- g. Install insert springs and reverse baulk ring on OD coupling sleeve. Then install them and OD baulk ring on OD counter gear.
- **Pay attention to direction of OD coupling sleeve.**

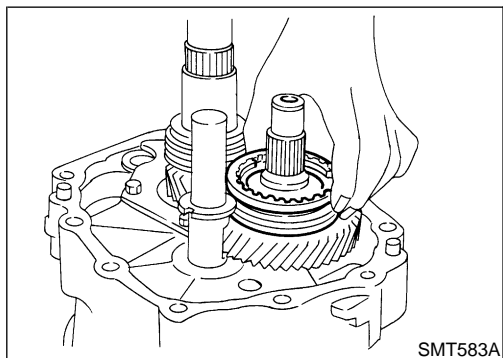

- h. Install reverse counter gear.
i. Install reverse gear needle bearing and then install reverse main gear, reverse idler gear and reverse idler thrust washers.

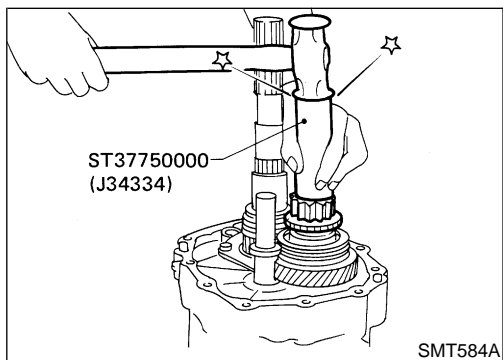

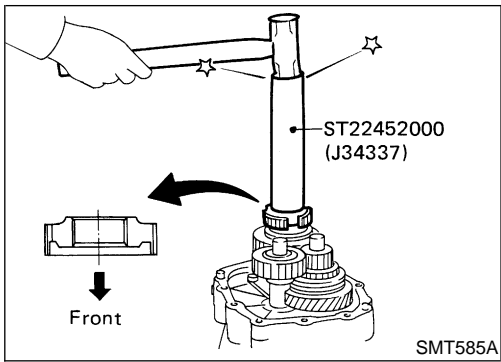

- j. Install reverse hub.
- Pay attention to its direction.

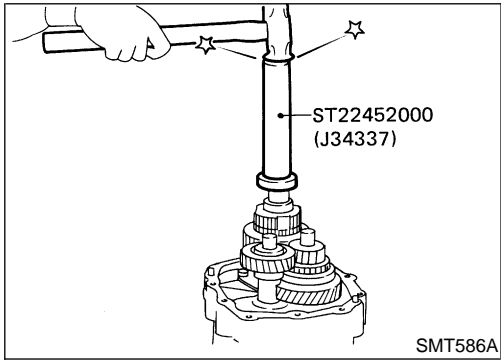

- k. Install mainshaft spacer and mainshaft rear bearing (2WD model).

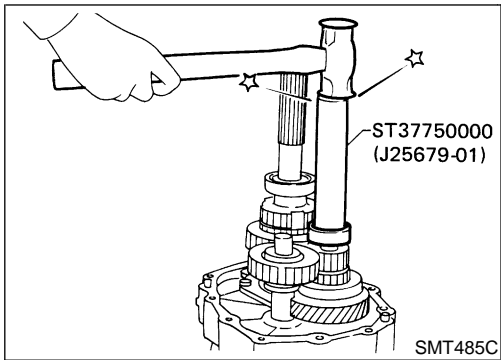

- l. Install counter gear rear end bearing.
- m. Separate adapter plate from transmission case and mount adapter plate on vise again.

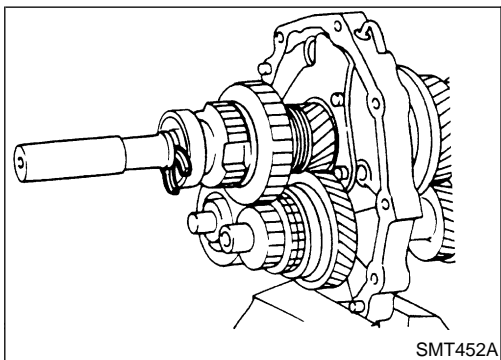

- n. Select proper mainshaft C-ring to minimize clearance of groove. Refer to "MAINSHAFT C-RING", MT-69.

Allowable clearance of groove:

0 - 0.1 mm (0 - 0.004 in)

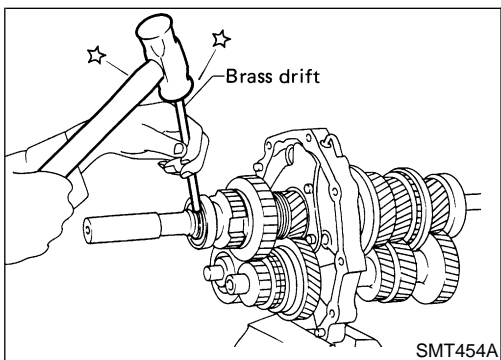

- o. Install selected C-ring, C-ring holder and mainshaft rear snap ring.

GI

MA

EM

LC

EC

FE

CL

MT

AT

TF

PD

AX

SU

BR

ST

RS

BT

HA

SC

EL

IDX

Gear Components (Cont'd)

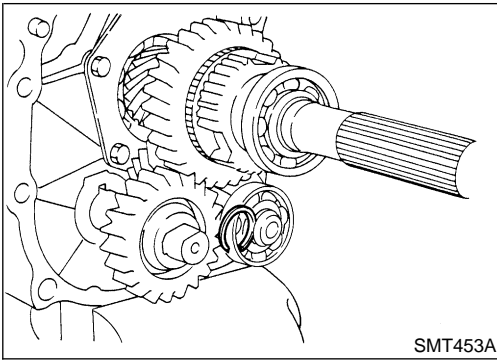

- p. Select proper counter gear rear snap ring to minimize clearance of groove. Refer to "COUNTER GEAR REAR SNAP RING", MT-69.

Allowable clearance of groove:

0 - 0.11 mm (0 - 0.004 in)

- q. Install selected counter gear rear snap ring.

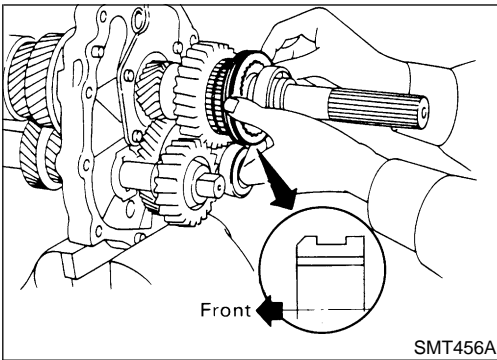
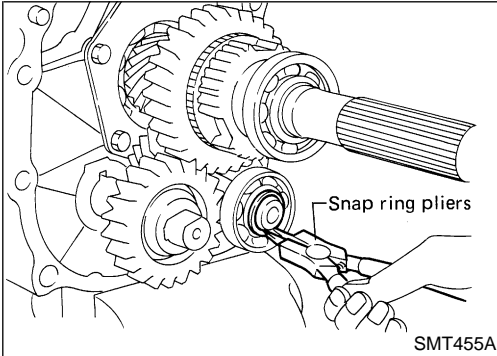

- r. Install reverse coupling sleeve.

- **Pay attention to its direction.**

- s. Measure each gear end play as a final check. Refer to "DISASSEMBLY", MT-50.

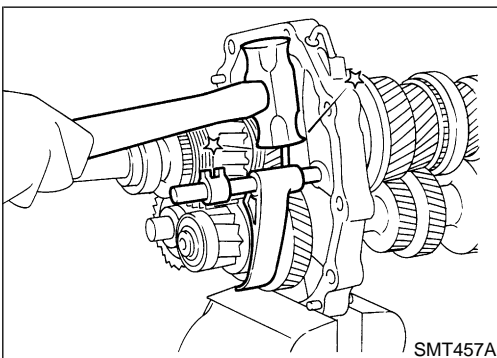

Shift Control Components

ASSEMBLY

NEMT0014

1. Install OD fork rod and OD shift fork. Then install retaining pin into OD shift fork.
2. Install 1st and 2nd, 3rd and 4th, and reverse shift forks onto coupling sleeve.

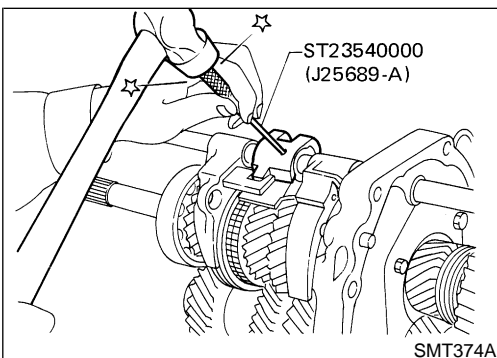

3. Install striking rod into hole of shift forks, striking lever and interlock and then install retaining pin into striking lever.

- **Make sure that striking rod moves smoothly.**

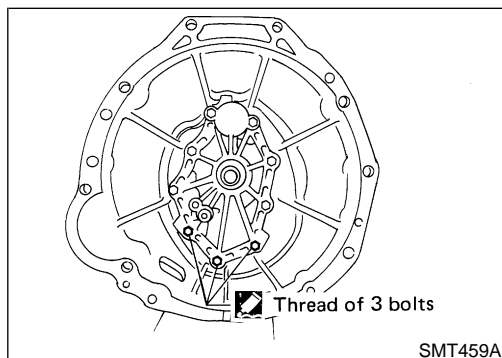
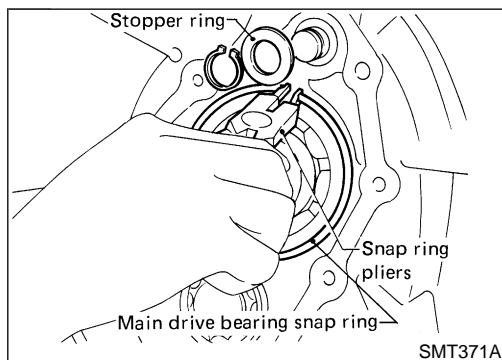
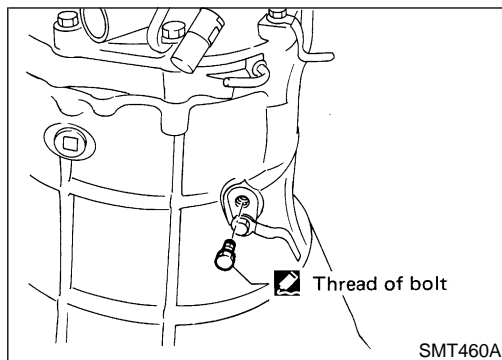
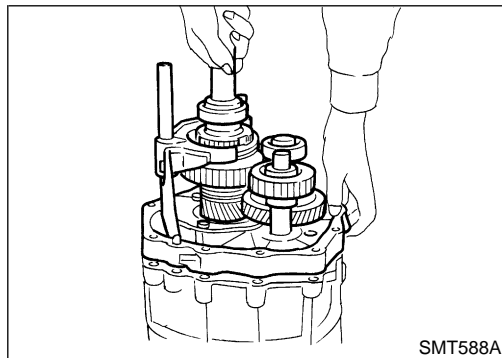
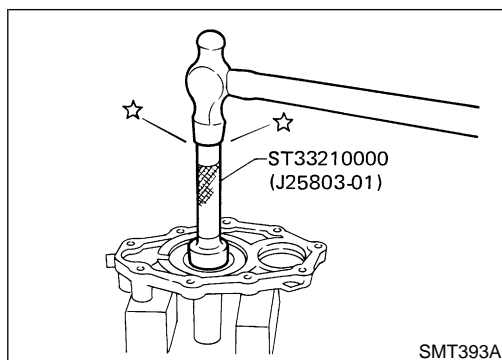

Case Components

ASSEMBLY

NEMT0015

1. Install front cover oil seal.
 - **Apply multi-purpose grease to seal lip.**
2. Install selected counter gear front bearing shim onto transmission case.
 - **Apply multi-purpose grease.**
3. Apply sealant to mating surface of transmission case.
4. Install gear assembly onto transmission case.
5. Install check spring and check ball into interlock stopper.
 - **Apply multi-purpose grease to check ball.**
6. Install interlock stopper assembly and then tighten check ball plug. Refer to "Shift Control Components", MT-47.
 - **Apply sealant to thread of check ball plug.**
7. Install stopper ring and main drive bearing snap ring.
8. Install front cover and gasket. Refer to "Case Components", MT-44.
 - **Apply sealant to thread of 3 bolts shown left.**
9. Apply sealant to mating surface of adapter plate.

GI

MA

EM

LC

EC

FE

CL

MT

AT

TF

PD

AX

SU

BR

ST

RS

BT

HA

SC

EL

IDX

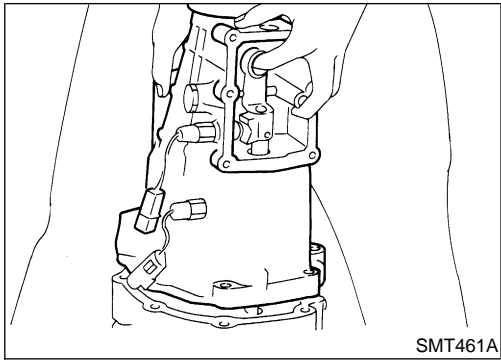

10. Install OD gear case together with striking arm.

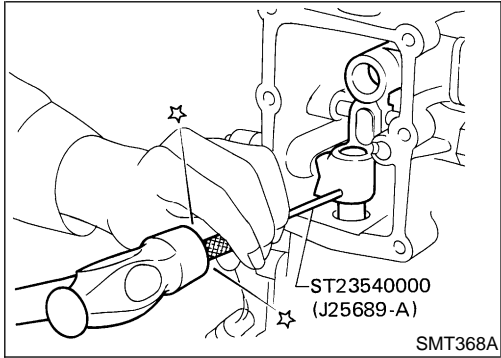

11. Install retaining pin into striking arm.

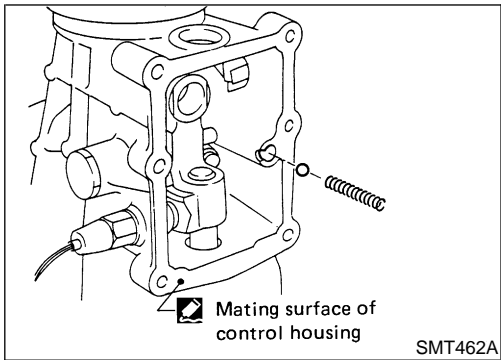

12. Install return spring and check ball and then install control housing.

- Apply sealant to mating surface of OD gear case. Refer to “Case Components”, MT-44.

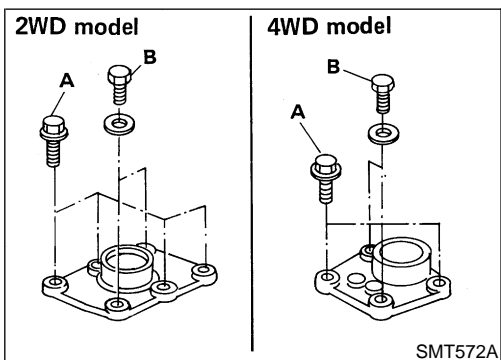

13. Tighten control housing bolts.

Bolt head size:

A bolts 12 mm (0.47 in)

B bolts 13 mm (0.51 in)

General Specifications

NEMT0016

	VG33E/VG33ER		
Transmission	FS5R30A		
	2WD	4WD	
Number of speed	5		
Shift pattern			
Synchromesh type	Warner		
	Gear ratio	Number of teeth	
		Mainshaft	Countershaft
Drive	—	22	32
1st	3.580	32	13
2nd	2.077	30	21
3rd	1.360	29	31
4th	1.000	—	—
OD	0.811	24	43
Reverse	3.636	30	12
Reverse idler gear	22		
Oil capacity ℓ (US pt, Imp pt)	2.8 (5-7/8, 4-7/8) — 2WD model		5.1 (10-3/4, 9) — 4WD model
Remarks	2nd & 3rd double baulk ring type synchronizer—VG33E model 1st, 2nd & 3rd double baulk ring type synchronizer—VG33ER model		

GI
MA
EM
LC
EC
FE
CL
MT
AT
TF
PD
AX
SU
BR
ST
RS
BT
HA
SC
EL
IDX

Gear End Play

NEMT0017
Unit: mm (in)

Gear	End play
1st main gear	0.23 - 0.33 (0.0091 - 0.0130)
2nd main gear	0.23 - 0.33 (0.0091 - 0.0130)
3rd main gear	0.06 - 0.16 (0.0024 - 0.0063)
OD counter gear	0.23 - 0.33 (0.0091 - 0.0130)
Reverse main gear	0.33 - 0.43 (0.0130 - 0.0169)
Counter gear	0.10 - 0.25 (0.0039 - 0.0098)
Reverse idler gear	0.30 - 0.53 (0.0118 - 0.0209)

Clearance Between Single Baulk Ring and Gear

NEMT0018
Unit: mm (in)

	Standard	Wear limit
1st (VG33E model)	1.05 - 1.3 (0.0413 - 0.0512)	0.7 (0.028)
Main drive	1.05 - 1.3 (0.0413 - 0.0512)	
OD	1.05 - 1.3 (0.0413 - 0.0512)	

SERVICE DATA AND SPECIFICATIONS (SDS)

FS5R30A

Clearance Between Single Baulk Ring and Gear (Cont'd)

DOUBLE BAULK RING

NEMT0018S01
Unit: mm (in)

VG33E model	2nd & 3rd baulk rings
VG33ER model	1st, 2nd & 3rd baulk rings

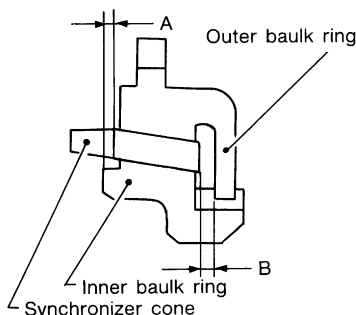

SMT742C

Dimension	Standard	Wear limit
A	0.7 - 0.9 (0.028 - 0.035)	0.2 (0.008)
B	0.6 - 1.1 (0.024 - 0.043)	

Distance Between Rear Surface of Reverse Cone and Reverse Baulk Ring

NEMT0019
Unit: mm (in)

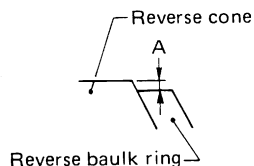

SMT428C

Dimension	Standard	Wear limit
A	-0.1 to 0.35 (-0.0039 to 0.0138)	0.7 (0.028)

Available Snap Ring

NEMT0020

MAIN DRIVE GEAR SNAP RING

NEMT0020S01
Unit: mm (in)

Allowable clearance		0 - 0.11 (0 - 0.004)	
Thickness	Part number*	Thickness	Part number*
1.89 (0.0744)	32204-01G60	2.03 (0.0799)	32204-01G63
1.95 (0.0768)	32204-01G61	2.07 (0.0815)	32204-01G64
1.99 (0.0783)	32204-01G62	2.11 (0.0831)	32204-01G65

*Always check with the Parts Department for the latest parts information.

MAINSHAFT FRONT SNAP RING

NEMT0020S02
Unit: mm (in)

Allowable clearance		0 - 0.1 (0 - 0.004)	
Thickness	Part number*	Thickness	Part number*
1.99 (0.0783)	32204-01G62	2.11 (0.0831)	32204-01G65
2.03 (0.0799)	32204-01G63	2.15 (0.0846)	32204-01G66
2.07 (0.0815)	32204-01G64	2.19 (0.0862)	32204-01G67

*Always check with the Parts Department for the latest parts information.

SERVICE DATA AND SPECIFICATIONS (SDS)

FS5R30A

Available Snap Ring (Cont'd)

COUNTER GEAR REAR SNAP RING

NEMT0020S03
Unit: mm (in)

Allowable clearance		0 - 0.11 (0 - 0.004)	
Thickness	Part number*	Thickness	Part number*
1.32 (0.0520)	32236-01G00	1.56 (0.0614)	32236-01G04
1.38 (0.0543)	32236-01G01	1.62 (0.0638)	32236-01G05
1.44 (0.0567)	32236-01G02	1.68 (0.0661)	32236-01G06
1.50 (0.0591)	32236-01G03	1.74 (0.0685)	32236-01G07

*Always check with the Parts Department for the latest parts information.

Available C-ring

NEMT0021

MAINSHAFT C-RING

NEMT0021S01
Unit: mm (in)

Allowable clearance		0 - 0.1 (0 - 0.004)	
Thickness	Part number*	Thickness	Part number*
2.63 (0.1035)	32348-01G15	3.19 (0.1256)	32348-01G07
2.70 (0.1063)	32348-01G00	3.26 (0.1283)	32348-01G08
2.77 (0.1091)	32348-01G01	3.33 (0.1311)	32348-01G09
2.84 (0.1118)	32348-01G02	3.40 (0.1339)	32348-01G10
2.91 (0.1146)	32348-01G03	3.47 (0.1366)	32348-01G11
2.98 (0.1173)	32348-01G04	3.54 (0.1394)	32348-01G12
3.05 (0.1201)	32348-01G05	3.61 (0.1421)	32348-01G13
3.12 (0.1228)	32348-01G06	3.68 (0.1449)	32348-01G14

*Always check with the Parts Department for the latest parts information.

Available Shim and Washer

NEMT0022

TABLE FOR SELECTING PROPER COUNTER GEAR FRONT BEARING THRUST WASHER

NEMT0022S01
Unit: mm (in)

Allowable clearance		0.10 - 0.26 (0.040 - 0.0102)	
Dial indicator deflection	Thickness of proper washer	Part number*	
0.93 - 1.02 (0.0366 - 0.0402)	0.80 (0.0315)	32218-01G00	
1.01 - 1.10 (0.0398 - 0.0433)	0.88 (0.0346)	32218-01G11	
1.09 - 1.18 (0.0429 - 0.0465)	0.96 (0.0378)	32218-01G12	
1.17 - 1.26 (0.0461 - 0.0496)	1.04 (0.0409)	32218-01G13	
1.25 - 1.34 (0.0492 - 0.0528)	1.12 (0.0441)	32218-01G14	
1.33 - 1.42 (0.0524 - 0.0559)	1.20 (0.0472)	32218-01G04	
1.41 - 1.50 (0.0555 - 0.0591)	1.28 (0.0504)	32218-01G15	
1.49 - 1.58 (0.0587 - 0.0622)	1.36 (0.0535)	32218-01G16	
1.57 - 1.66 (0.0618 - 0.0654)	1.44 (0.0567)	32218-01G17	

*Always check with the Parts Department for the latest parts information.

SERVICE DATA AND SPECIFICATIONS (SDS)

FS5R30A

Available Shim and Washer (Cont'd)

REVERSE IDLER REAR THRUST WASHER

NEMT0022S02
Unit: mm (in)

Allowable clearance		0.30 - 0.53 (0.0119 - 0.0208)
Thickness		Part number*
A	1.97 (0.0776)	32284-01G10
B	2.07 (0.0815)	32284-01G11

*Always check with the Parts Department for the latest parts information.