

# RESTRAINT SYSTEM

## SECTION **RS**

### CONTENTS

<b>SEAT BELTS</b> .....	3	INSTALLATION.....	24	GI
Precautions .....	3	Passenger Air Bag Deactivation Switch .....	25	MA
SUPPLEMENTAL RESTRAINT SYSTEM (SRS)		REMOVAL.....	25	EM
"AIR BAG" AND "SEAT BELT PRE-TENSIONER" .....	3	INSTALLATION.....	25	LC
PRECAUTIONS FOR SEAT BELT SERVICE .....	3	Passenger Air Bag Deactivation Switch Lock		EC
AFTER A COLLISION.....	3	Cylinder .....	26	FE
Front Seat Belt.....	5	REMOVAL.....	26	CL
REMOVAL AND INSTALLATION.....	5	INSTALLATION.....	26	AT
Rear Seat Belt .....	6	Passenger Air Bag Deactivation Switch Indicator .....	27	TF
REMOVAL AND INSTALLATION.....	6	REMOVAL.....	27	PD
Seat Belt Inspection.....	8	INSTALLATION.....	27	AX
AFTER A COLLISION.....	8	Disposal of Air Bag Module and Seat Belt Pre-		SU
PRELIMINARY CHECKS .....	8	tensioner .....	27	BR
SEAT BELT RETRACTOR ON-VEHICLE CHECK .....	9	CHECKING DEPLOYMENT TOOL.....	28	ST
SEAT BELT RETRACTOR OFF-VEHICLE CHECK .....	10	DEPLOYMENT PROCEDURES FOR AIR BAG		RS
Top Tether Strap Child Restraint .....	11	MODULE (OUTSIDE OF VEHICLE).....	29	BT
REMOVAL AND INSTALLATION.....	11	DEPLOYMENT OF AIR BAG MODULE AND SEAT		HA
<b>SUPPLEMENTAL RESTRAINT SYSTEM (SRS)</b> .....	12	BELT PRE-TENSIONER WHILE MOUNTED IN		SC
Precautions .....	12	VEHICLE .....	33	EL
SUPPLEMENTAL RESTRAINT SYSTEM (SRS)		DISPOSING OF AIR BAG MODULE AND SEAT		IDX
"AIR BAG" AND "SEAT BELT PRE-TENSIONER" .....	12	BELT PRE-TENSIONER.....	33	
PRECAUTIONS FOR SRS "AIR BAG" AND "SEAT		Trouble Diagnoses Introduction.....	34	
BELT PRE-TENSIONER" SERVICE .....	12	DIAGNOSIS FUNCTION.....	34	
AFTER A COLLISION.....	13	DIAGNOSIS MODE FOR CONSULT-II .....	34	
WIRING DIAGRAMS AND TROUBLE DIAGNOSIS .....	13	Ⓜ HOW TO CHANGE SELF-DIAGNOSIS MODE		
Preparation .....	14	WITH CONSULT-II .....	35	
SPECIAL SERVICE TOOLS .....	14	Ⓧ HOW TO CHANGE SELF-DIAGNOSIS MODE		
Description .....	15	WITHOUT CONSULT-II .....	35	
PASSENGER AIR BAG DEACTIVATION SWITCH		HOW TO ERASE SELF-DIAGNOSIS RESULTS .....	36	
(KING CAB MODELS) .....	16	How to Perform Trouble Diagnoses for Quick		
SRS Component Parts Location .....	17	and Accurate Repair .....	37	
Diagnosis Sensor Unit.....	17	INFORMATION FROM CUSTOMER.....	37	
REMOVAL AND INSTALLATION.....	17	PRELIMINARY CHECK .....	37	
Seat Belt Pre-tensioner .....	18	WORK FLOW .....	38	
REMOVAL AND INSTALLATION.....	18	Wiring Diagram - SRS -.....	39	
Driver Air Bag Module and Spiral Cable .....	19	Passenger Air Bag Deactivation Switch Indicator		
REMOVAL AND INSTALLATION.....	19	Operation Check.....	41	
REMOVAL.....	19	SRS Operation Check .....	42	
INSTALLATION.....	21	DIAGNOSTIC PROCEDURE 1 .....	42	
Front Passenger Air Bag Module .....	22	Ⓜ Trouble Diagnoses with CONSULT-II.....	42	
REMOVAL.....	22	DIAGNOSTIC PROCEDURE 2 .....	42	

# CONTENTS (Cont'd)

DIAGNOSTIC PROCEDURE 3.....	47	Trouble Diagnoses: "AIR BAG" Warning Lamp	
DIAGNOSTIC PROCEDURE 4 (CONTINUED		Does Not Turn Off .....	59
FROM DIAGNOSTIC PROCEDURE 2) .....	48	DIAGNOSTIC PROCEDURE 9.....	59
DIAGNOSTIC PROCEDURE 5.....	49	Trouble Diagnoses: "AIR BAG" Warning Lamp	
⊗ Trouble Diagnoses without CONSULT-II.....	53	Does Not Turn On .....	61
DIAGNOSTIC PROCEDURE 6.....	53	DIAGNOSTIC PROCEDURE 10 .....	61
DIAGNOSTIC PROCEDURE 7.....	57	Collision Diagnosis .....	61
DIAGNOSTIC PROCEDURE 8 (CONTINUED		SRS INSPECTION .....	62
FROM DIAGNOSTIC PROCEDURE 6) .....	58		

## Precautions

**SUPPLEMENTAL RESTRAINT SYSTEM (SRS) “AIR BAG” AND “SEAT BELT PRE-TENSIONER”**

NERS0001

The Supplemental Restraint System such as “AIR BAG” and “SEAT BELT PRE-TENSIONER” used along with a seat belt, helps to reduce the risk or severity of injury to the driver and front passenger in a frontal collision. The Supplemental Restraint System consists of air bag modules (located in the center of the steering wheel and in the instrument panel on the passenger side), seat belt pre-tensioners, a diagnosis sensor unit, warning lamp, wiring harness, and spiral cable.

The vehicle (except Crew Cab model) is equipped with a passenger air bag deactivation switch. Because no rear seat exists where a rear-facing child restraint can be placed, the switch is designed to turn off the passenger air bag so that a rear-facing child restraint can be used in the front passenger seat. The switch is located in the center of the instrument panel, near the ashtray. When the switch is turned to the ON position, the passenger air bag is enabled and could inflate in a frontal collision. When the switch is turned to the OFF position, the passenger air bag is disabled and will not inflate in a frontal collision. A passenger air bag OFF indicator on the instrument panel lights up when the passenger air bag is switched OFF. The driver air bag always remains enabled and is not affected by the passenger air bag deactivation switch.

**WARNING:**

- To avoid rendering the SRS inoperative, which could increase the risk of personal injury or death in the event of a collision which would result in air bag inflation, all maintenance should be performed by an authorized NISSAN dealer.
- Improper maintenance, including incorrect removal and installation of the SRS, can lead to personal injury caused by unintentional activation of the system.
- Do not use electrical test equipment on any circuit related to the SRS unless instructed to in this Service Manual. SRS wiring harnesses can be identified by yellow harness connectors.
- The vehicle (except Crew Cab model) is equipped with a passenger air bag deactivation switch which can be operated by the customer. When the passenger air bag is switched OFF, the passenger air bag is disabled and will not inflate in a frontal collision. When the passenger air bag is switched ON, the passenger air bag is enabled and could inflate in a frontal collision. After SRS maintenance or repair, make sure the passenger air bag deactivation switch is in the same position (ON or OFF) as when the vehicle arrived for service.

**PRECAUTIONS FOR SEAT BELT SERVICE**

NERS0002

**CAUTION:**

- Before removing the seat belt pre-tensioner assembly, turn the ignition switch OFF, disconnect both battery cables and wait at least 3 minutes.
- After replacing or reinstalling seat belt pre-tensioner assembly, or reconnecting seat belt pre-tensioner assembly connector, ensure entire SRS operates properly. Refer to “SRS Operation Check”, RS-42.
- Do not disassemble buckle or seat belt assembly.
- Do not reuse seat belt anchor bolts after removal. Replace with new ones.
- Never oil tongue and buckle.
- If any component (including anchor bolts) of seat belt assembly is questionable, do not repair. Replace the whole seat belt assembly.
- If webbing is cut, frayed, or damaged, replace seat belt assembly.
- When replacing seat belt assembly, use a genuine NISSAN seat belt assembly.

**AFTER A COLLISION**

NERS0044

**WARNING:**

Inspect all seat belt assemblies including retractors, buckles and attaching hardware after any collision.

NISSAN recommends that all seat belt assemblies in use during a collision be replaced unless the collision was minor and the belts show no damage and continue to operate properly. Failure to do so could result in serious personal injury in an accident. Seat belt assemblies not in use during a collision should also be replaced if either damage or improper operation is noted. Seat belt assemblies which are equipped with pre-tensioners should be replaced even if the seat belts are not in use during a frontal collision in which the air bags are deployed.

Replace any seat belt assembly (including anchor bolts) if:

- The seat belt was in use at the time of a collision (except after minor collisions when the belts, retractors

## SEAT BELTS

### *Precautions (Cont'd)*

---

and buckles show no damage and continue to operate properly).

- The seat belt was damaged in an accident (i.e., torn webbing, bent retractor or guide, etc.).
- The seat belt attaching point was damaged in an accident. Inspect the seat belt attaching area for damage or distortion and repair as necessary before installing a new seat belt assembly.
- Anchor bolts are deformed or worn out.
- The seat belt assembly is equipped with a pre-tensioner, even if the seat belt is not in use during a collision in which the air bags are deployed.

# SEAT BELTS

Front Seat Belt

## Front Seat Belt

### REMOVAL AND INSTALLATION

=NERS0003

Slide the seat all the way forward and tilt the seatback toward the front.

1. Remove buckle. For driver side, disconnect seat belt switch connector.
2. Remove floor anchor bolts.
3. Remove adjuster cover and upper guide loop anchor bolt.
4. Remove center pillar lower and upper garnishes. Refer to **BT-24**, "SIDE AND FLOOR TRIM".
5. Remove two adjuster bolts and adjuster assembly.
6. Remove retractor anchor bolt and screw.
7. Remove retractor.
8. Disconnect seat belt pre-tensioner connector.

SEC. 868

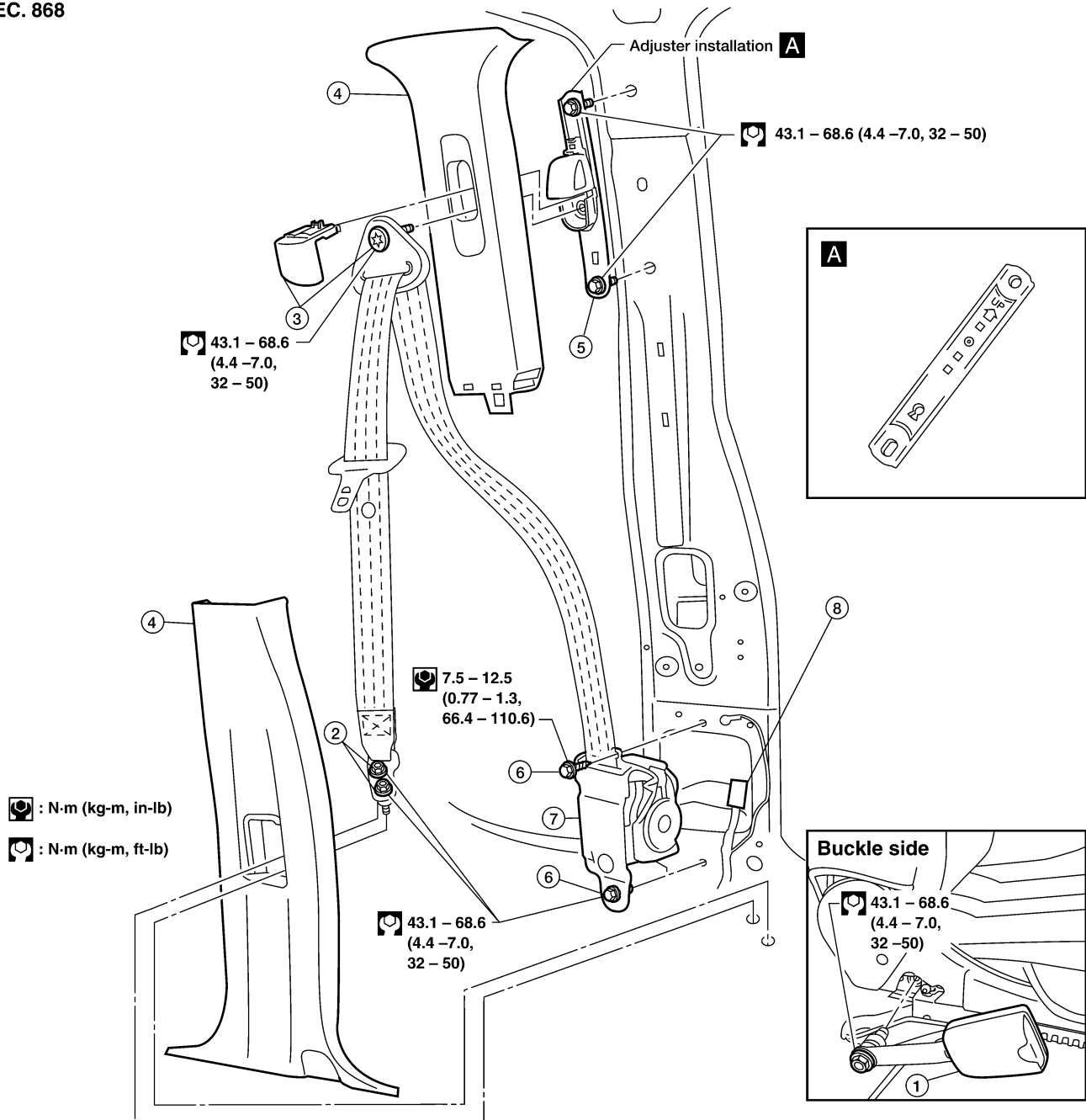

: N·m (kg·m, in·lb)

: N·m (kg·m, ft·lb)

WRS230

GI  
MA  
EM  
LC  
EC  
FE  
CL  
MT  
AT  
TF  
PD  
AX  
SU  
BR  
ST  
RS  
BT  
HA  
SC  
EL  
IDX

# SEAT BELTS

Rear Seat Belt

## Rear Seat Belt

### REMOVAL AND INSTALLATION

#### King Cab Models

1. Remove underseat storage.
2. Remove buckle.
3. Remove seat belt anchor bolt.

=NERS0004

NERS0004S01

SEC. 869

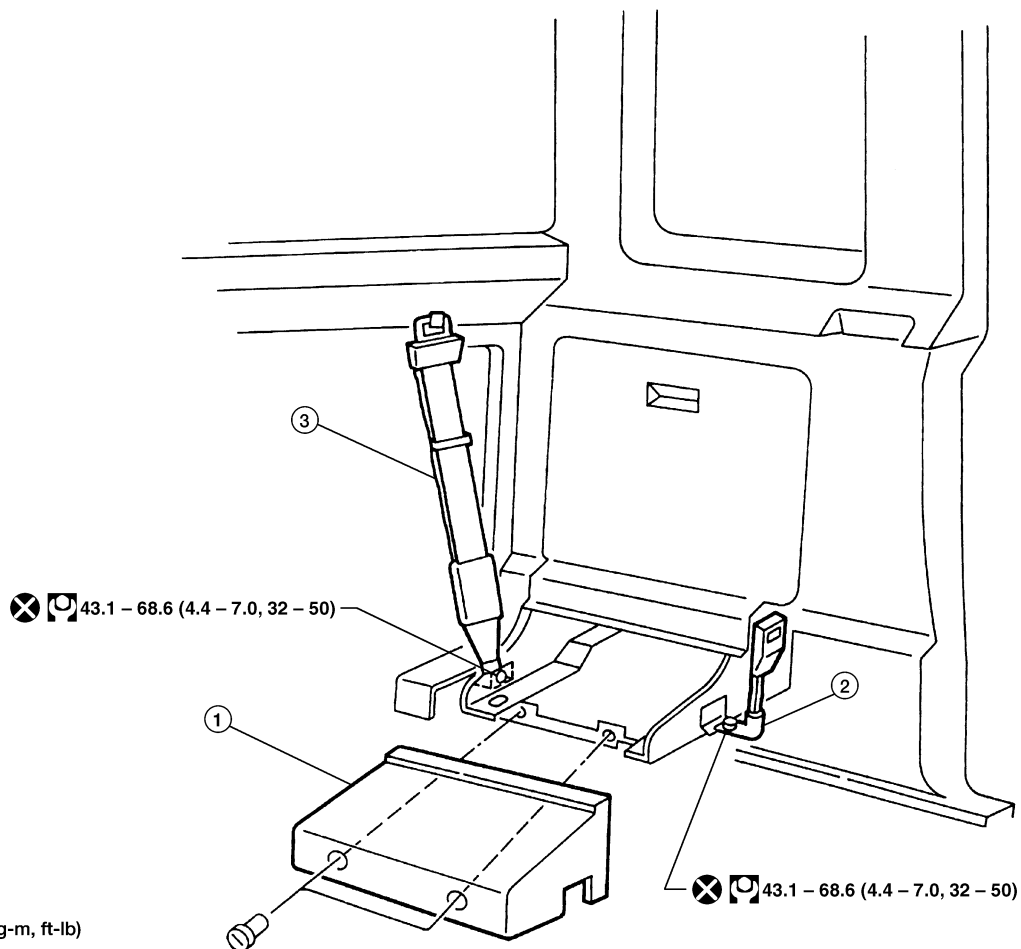

: N-m (kg-m, ft-lb)

LRS231

# SEAT BELTS

Rear Seat Belt (Cont'd)

=NERS0004S02

## Crew Cab Models

1. Remove lower seat belt anchor bolt.
2. Remove shoulder anchor cover.
3. Remove shoulder anchor bolt.
4. Remove retractor bolt.
5. Remove retractor.
6. Remove anchor bolts.
7. Remove seat belt assembly.

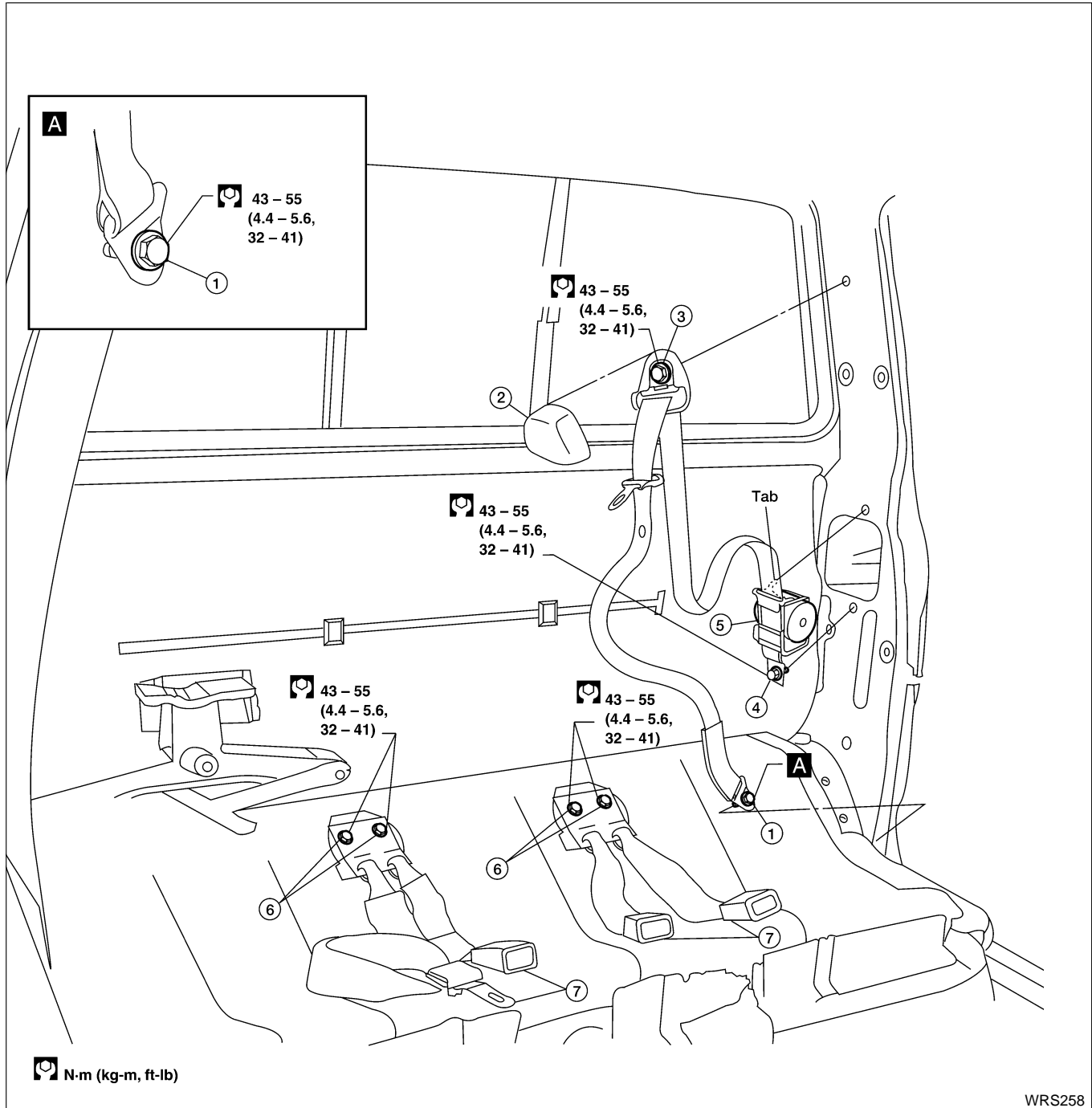

GI

MA

EM

LC

EC

FE

CL

MT

AT

TF

PD

AX

SU

BR

ST

**RS**

BT

HA

SC

EL

IDX

# SEAT BELTS

## Seat Belt Inspection

=NERS0029

NERS0029S01

### AFTER A COLLISION

#### **WARNING:**

Inspect all seat belt assemblies including retractors and attaching hardware after any collision. NISSAN recommends that all seat belt assemblies in use during a collision be replaced unless the collision was minor and the belts show no damage and continue to operate properly. Failure to do so could result in serious personal injury in an accident. Seat belt assemblies not in use during a collision should also be replaced if either damage or improper operation is noted. Seat belt assemblies which are equipped with pre-tensioners should be replaced even if the seat belts are not in use during a frontal collision in which the air bags are deployed.

Replace any seat belt assembly (including anchor bolts) if:

- The seat belt was in use at the time of a collision (except after minor collisions when the belts, retractors and buckles show no damage and continue to operate properly.)
- The seat belt was damaged in an accident (i.e. torn webbing, bent retractor or guide, etc.).
- The seat belt attaching point was damaged in an accident. Inspect the seat belt attaching area for damage or distortion and repair as necessary before installing a new seat belt assembly.
- The seat belt assembly is equipped with a pre-tensioner, even if the seat belt is not in use during a collision in which the air bags are deployed.

### PRELIMINARY CHECKS

NERS0029S02

1. Check the seat belt warning lamp/chime for proper operation as follows:
  - a. Switch ignition ON. With driver seat belt unfastened, the seat belt warning lamp should illuminate. Also, the seat belt warning chime should sound for about seven seconds.
  - b. Fasten driver seat belt. The seat belt warning lamp should go out and the chime (if sounding) should stop.
2. If the "AIR BAG" warning lamp is blinking, conduct self-diagnosis using CONSULT-II and "AIR BAG" warning lamp. Refer to "SRS Operation Check", RS-42.
3. Check that the seat belt retractor, seat belt anchor and buckle bolts are securely attached.
4. Check the shoulder seat belt guide and shoulder belt height adjuster for front seats. Ensure guide swivels freely and that belt lays flat and does not bind in guide. Ensure height adjuster operates properly and holds securely.
5. Check retractor operation:
  - a. Fully extend the seat belt webbing and check for twists, tears or other damage.
  - b. Allow the seat belt to retract. Ensure that belt returns smoothly and completely into the retractor. If the seat belt does not return smoothly, wipe the inside of the loops with a clean paper cloth etc. Dirt built up in the loops of the upper anchors can cause the seat belts to retract slowly.

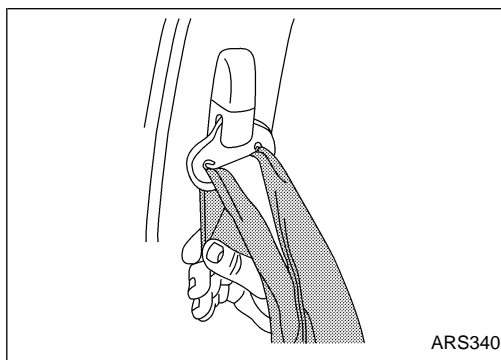

- c. Fasten the seat belt. Pull firmly on belt and buckle to ensure belt remains latched. Unfasten seat belt. Ensure belt releases freely and buckle button returns to original position.
6. For non-retractable seat belts, check that the seat belts are accessible. Check seat belt webbing for twists, tears or other damage. Fasten the seat belt. Pull firmly on belt and buckle to ensure belt remains latched. Unfasten seat belts. Ensure belt releases freely and buckle button returns to original position.
  7. Repeat steps above as necessary to check the other seat belts.



# SEAT BELTS

Seat Belt Inspection (Cont'd)

## SEAT BELT RETRACTOR ON-VEHICLE CHECK

-NERS0029S03

### Emergency Locking Retractors (ELR) and Automatic Locking Retractors (ALR)

NERS0029S0301

#### NOTE:

All seat belt retractors are of the Emergency Locking (ELR) type. In an emergency (sudden stop) the retractor will lock and prevent the belt from extending any further. All outboard 3-point type seat belt retractors except the driver seat belt also have an Automatic Locking (ALR) mode. The ALR mode (also called child restraint mode) is used when installing child seats in outboard seating positions. The ALR mode is activated when the seat belt is fully extended. When the belt is then retracted partially, the ALR mode automatically locks the seat belt in a specific position so the belt cannot be extended any further. To cancel the ALR mode, allow the seat belt to fully wind back into the retractor.

Check the seat belt retractors using the following test(s) to determine if a retractor assembly is operating properly.

#### ELR Function Stationary Check

NERS0029S0302

Grasp the shoulder belt and pull forward quickly. The retractor should lock and prevent the belt from extending further.

#### ALR Function Stationary Check

NERS0029S0304

1. Pull out entire length of seat belt from retractor until a click is heard.
2. Retract the belt partially. A clicking noise should be heard as the belt retracts, indicating that the retractor is in the Automatic Locking (ALR) mode.
3. Grasp the seat belt and try to pull out of retractor. The belt must lock and not extend any further. If NG, replace the retractor assembly.
4. Allow the entire length of the belt to retract to cancel the automatic locking mode.

#### ELR Function Moving Check (all outboard seating positions)

NERS0029S0303

#### WARNING:

Perform the following test in a safe, open area clear of other vehicles and obstructions (for example, a large, empty parking lot). Road surface must be paved and dry. DO NOT perform the following test on wet roads, gravel roads, public streets or highways. This could result in an accident and serious personal injury. The driver and passenger must be prepared to brace themselves in the event the retractor does not lock.

1. Fasten driver seat belt. Buckle a passenger into the seat for the belt that is to be tested.
2. Proceed to the designated safe area.
3. Drive the vehicle at approximately 16 km/h (10 mph). Notify any passengers of a pending sudden stop and the driver and passenger must be prepared to brace themselves in the event the retractor does not lock. Apply brakes firmly and make a very hard stop.

During stop, seat belts should lock and not extend. If the seat belt retractor assembly does not lock, perform the retractor off-vehicle check.

GI

MA

EM

LC

EC

FE

CL

MT

AT

TF

PD

AX

SU

BR

ST

RS

BT

HA

SC

EL

IDX

# SEAT BELTS

Seat Belt Inspection (Cont'd)

## SEAT BELT RETRACTOR OFF-VEHICLE CHECK

=NERS0029S04

1. Remove the seat belt retractor assembly.
2. Slowly pull out belt while tilting the retractor assembly forward from the mounted position as shown in the illustration.

**15 degrees or less tilt: Belt can be pulled out.**

**35 degrees or more tilt: Belt locks and cannot be pulled out.**

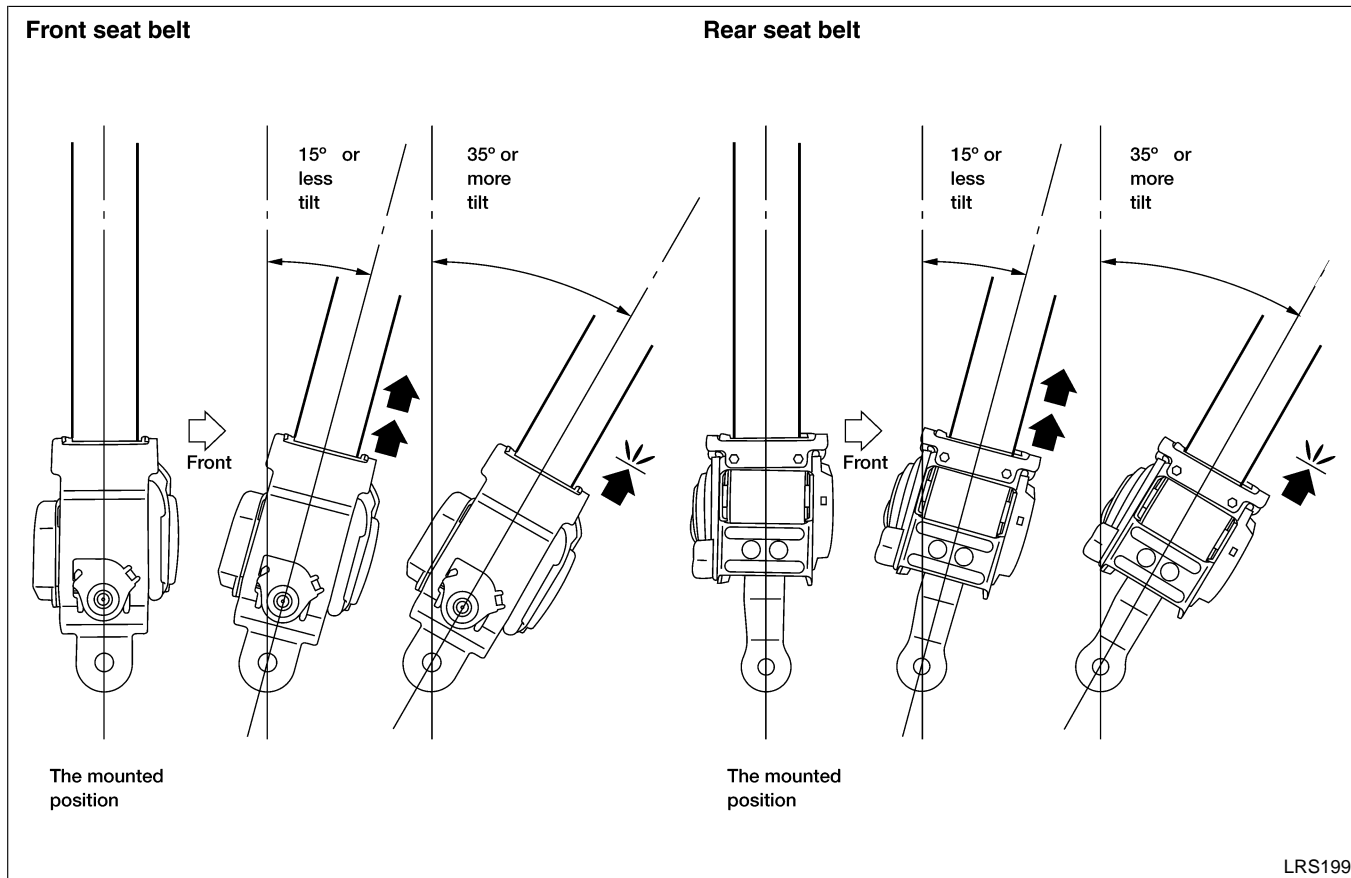

If NG, replace the retractor assembly.

# SEAT BELTS

Top Tether Strap Child Restraint

## Top Tether Strap Child Restraint REMOVAL AND INSTALLATION King Cab Models

NERS0053

NERS0053S01

NERS0053S0101

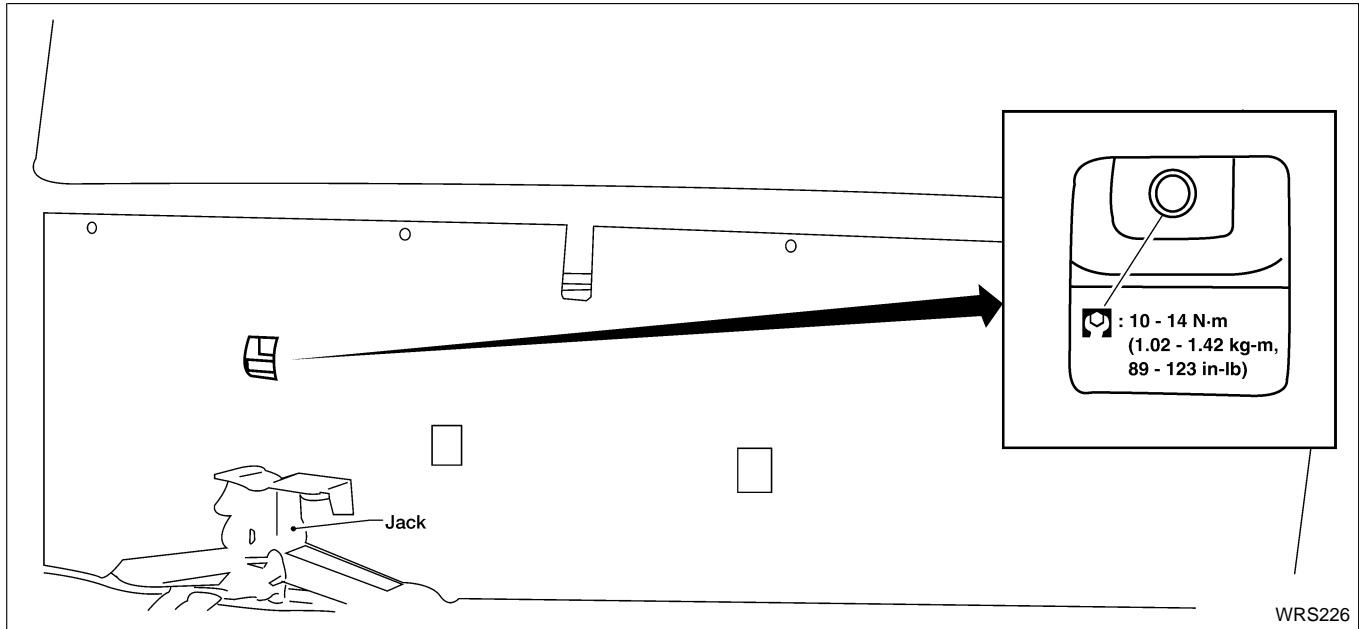

**CAUTION:**  
Replace anchor bolts if they are deformed or worn out.

## Crew Cab Models

NERS0053S0102

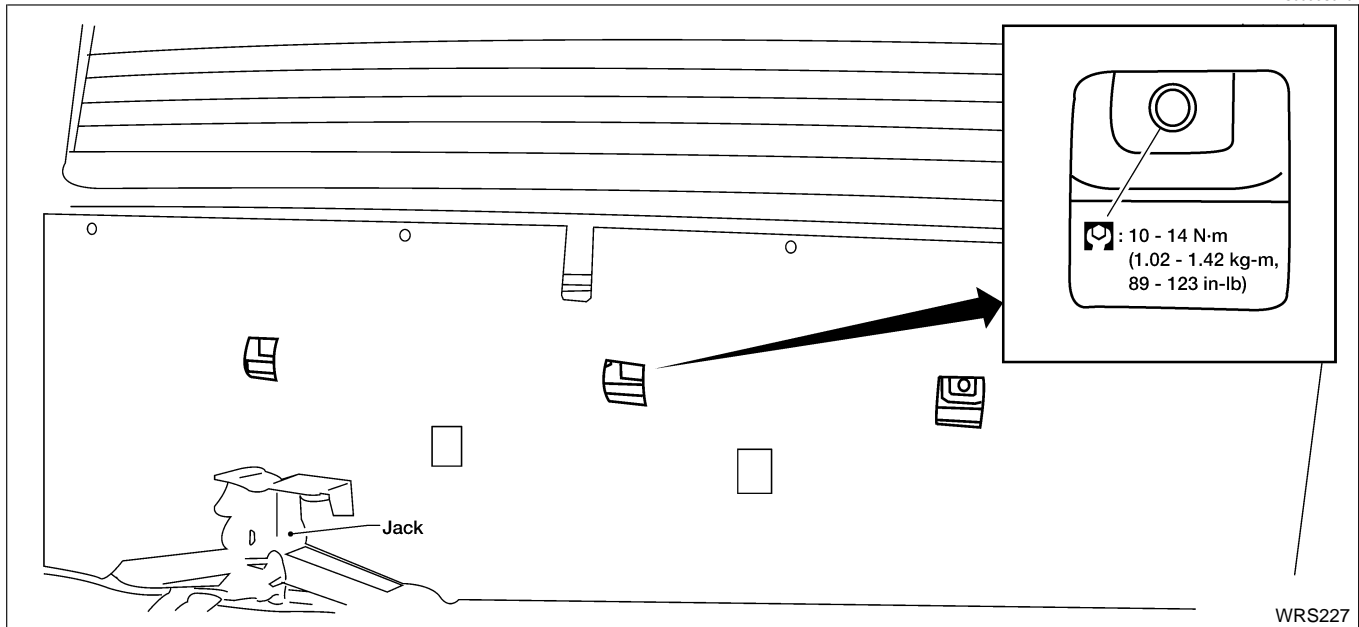

**CAUTION:**  
Replace anchor bolts if they are deformed or worn out.

GI  
MA  
EM  
LC  
EC  
FE  
CL  
MT  
AT  
TF  
PD  
AX  
SU  
BR  
ST  
RS  
BT  
HA  
SC  
EL  
IDX

# SUPPLEMENTAL RESTRAINT SYSTEM (SRS)

Precautions

## Precautions

### SUPPLEMENTAL RESTRAINT SYSTEM (SRS) “AIR BAG” AND “SEAT BELT PRE-TENSIONER”

NERS0005

The Supplemental Restraint System such as “AIR BAG” and “SEAT BELT PRE-TENSIONER” used along with a seat belt, helps to reduce the risk or severity of injury to the driver and front passenger in a frontal collision. The Supplemental Restraint System consists of air bag modules (located in the center of the steering wheel and in the instrument panel on the passenger side), seat belt pre-tensioners, a diagnosis sensor unit, warning lamp, wiring harness, and spiral cable.

The vehicle (except Crew Cab model) is equipped with a passenger air bag deactivation switch. Because no rear seat exists where a rear-facing child restraint can be placed, the switch is designed to turn off the passenger air bag so that a rear-facing child restraint can be used in the front passenger seat. The switch is located in the center of the instrument panel, near the ashtray. When the switch is turned to the ON position, the passenger air bag is enabled and could inflate in a frontal collision. When the switch is turned to the OFF position, the passenger air bag is disabled and will not inflate in a frontal collision. A passenger air bag OFF indicator on the instrument panel lights up when the passenger air bag is switched OFF. The driver air bag always remains enabled and is not affected by the passenger air bag deactivation switch.

#### **WARNING:**

- To avoid rendering the SRS inoperative, which could increase the risk of personal injury or death in the event of a collision which would result in air bag inflation, all maintenance should be performed by an authorized NISSAN dealer.
- Improper maintenance, including incorrect removal and installation of the SRS, can lead to personal injury caused by unintentional activation of the system.
- Do not use electrical test equipment on any circuit related to the SRS unless instructed to in this Service Manual. SRS wiring harnesses can be identified by yellow harness connectors.
- The vehicle (except Crew Cab model) is equipped with a passenger air bag deactivation switch which can be operated by the customer. When the passenger air bag is switched OFF, the passenger air bag is disabled and will not inflate in a frontal collision. When the passenger air bag is switched ON, the passenger air bag is enabled and could inflate in a frontal collision. After SRS maintenance or repair, make sure the passenger air bag deactivation switch is in the same position (ON or OFF) as when the vehicle arrived for service.

### PRECAUTIONS FOR SRS “AIR BAG” AND “SEAT BELT PRE-TENSIONER” SERVICE

NERS0006

- Do not use a circuit tester to check SRS circuits unless instructed to in this Service Manual.
- Before servicing the SRS, turn ignition switch OFF, disconnect both battery cables and wait at least 3 minutes.  
For approximately 3 minutes after the cables are removed, it is still possible for the air bags and seat belt pre-tensioners to deploy. Therefore, do not work on any SRS connectors or wires until at least 3 minutes have passed.
- Air bag diagnosis sensor unit must always be installed with forward mark “←” pointing toward the front of the vehicle for proper operation. Also check air bag diagnosis sensor unit for deformities, dents, cracks and rust before installation and replace as required.
- The spiral cable must be aligned in the neutral position since its rotations are limited. Do not rotate steering column while steering gear is removed to avoid damaging spiral cable.
- Handle air bag module carefully. Always place it with the pad side facing upward.
- Conduct Self-diagnosis to check entire SRS for proper function after replacing any components. Refer to “SRS Operation Check”, “TROUBLE DIAGNOSES — Supplemental Restraint System (SRS)”, RS-42.
- After air bag inflates, the instrument panel assembly should be replaced if damaged.

## AFTER A COLLISION

-NERS0045

### WARNING:

Inspect all seat belt assemblies including retractors, buckles and attaching hardware after any collision.

NISSAN recommends that all seat belt assemblies in use during a collision be replaced unless the collision was minor and the belts show no damage and continue to operate properly. Failure to do so could result in serious personal injury in an accident. Seat belt assemblies not in use during a collision should also be replaced if either damage or improper operation is noted. Seat belt assemblies which are equipped with pre-tensioners should be replaced even if the seat belts are not in use during a frontal collision in which the air bags are deployed.

Replace any seat belt assembly (including anchor bolts) if:

- The seat belt was in use at the time of a collision (except after minor collisions when the belts, retractors and buckles show no damage and continue to operate properly).
- The seat belt was damaged in an accident (i.e., torn webbing, bent retractor or guide, etc.).
- The seat belt attaching point was damaged in an accident. Inspect the seat belt attaching area for damage or distortion and repair as necessary before installing a new seat belt assembly.
- Anchor bolts are deformed or worn out.
- The seat belt assembly is equipped with a pre-tensioner, even if the seat belt is not in use during a collision in which the air bags are deployed.

## WIRING DIAGRAMS AND TROUBLE DIAGNOSIS

NERS0007

When you read wiring diagrams, refer to the following:

- **GI-11**, "HOW TO READ WIRING DIAGRAMS"
- **EL-10**, "POWER SUPPLY ROUTING" for power distribution circuit

When you perform trouble diagnosis, refer to the following:

- **GI-34**, "How to Follow Test Groups In Trouble Diagnoses"
- **GI-23**, "HOW TO PERFORM EFFICIENT DIAGNOSIS FOR AN ELECTRICAL INCIDENT"

GI

MA

EM

LC

EC

FE

CL

MT

AT

TF

PD

AX

SU

BR

ST

**RS**

BT

HA

SC

EL

IDX

# SUPPLEMENTAL RESTRAINT SYSTEM (SRS)

Preparation

## Preparation

### SPECIAL SERVICE TOOLS

=NERS0008

The actual shapes of Kent-Moore tools may differ from those of special service tools illustrated here.

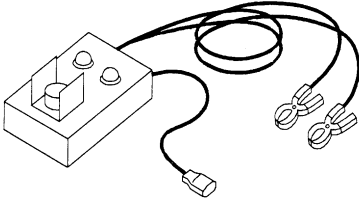
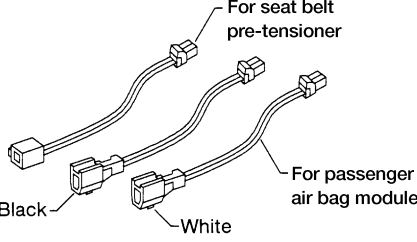
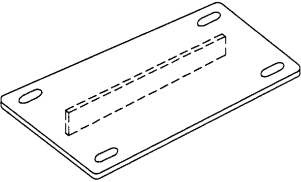
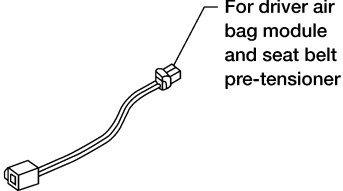
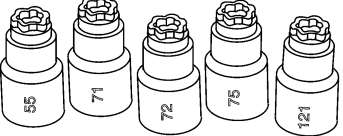
Tool number (Kent-Moore No.) Tool name	Description
KV991072S0 (J38381-KIT) Air bag deployment kit KV99106400 (J38381) Deployment tool	 <p>NT357</p> <p>Disposing of air bag module and seat belt pre-tensioner</p>
KV991065S0 (J38381-30) Deployment tool adapters	 <p>ARS269</p>
KV99105300 (J41246) Air bag module bracket	 <p>NT354</p> <p>Anchoring air bag module</p>
KV99109000 (J44230) Deployment tool adapter	 <p>LRS138</p> <p>For driver air bag module and seat belt pre-tensioner</p>
(J-44615) Air bag master key set	 <p>LRS210</p> <p>Removing and installing accessory air bag locking bolts</p>

\*: Special tool or commercial equivalent

# SUPPLEMENTAL RESTRAINT SYSTEM (SRS)

Description

## Description

NERS0009

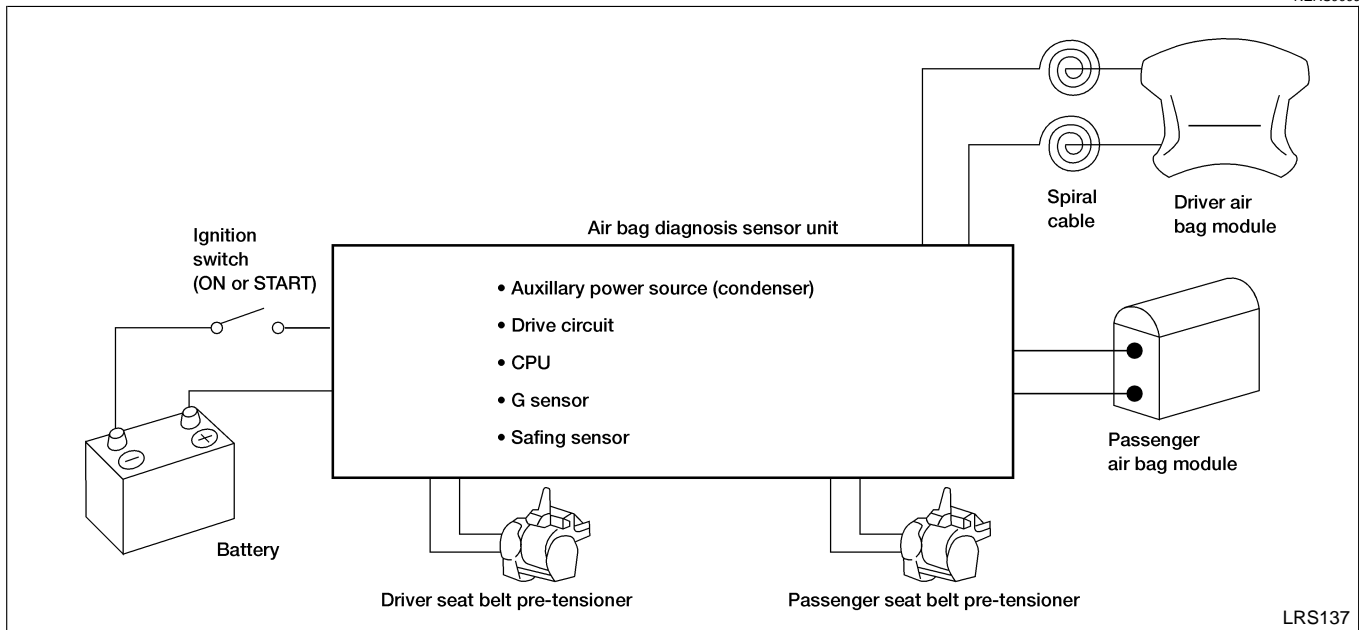

LRS137

The air bags and seat belt pre-tensioners deploy if the air bag diagnosis sensor unit activates while the ignition switch is in the ON or START position.

The air bag diagnosis sensor unit will deploy the air bags and the seat belt pre-tensioners if the G sensor activates simultaneously with the safing sensor while the ignition switch is ON.

Ignition	Diagnosis sensor unit		Driver air bag	Passenger air bag	Driver seat belt pre-tensioner	Passenger seat belt pre-tensioner
	G sensor	Safing sensor				
ON	ON	ON	Deploy			
ON	—	ON	Deploy			
ON	ON	ON	Deploy			

GI  
MA  
EM  
LC  
EC  
FE  
CL  
MT  
AT  
TF  
PD  
AX  
SU  
BR  
ST  
RS  
BT  
HA  
SC  
EL  
IDX

## SUPPLEMENTAL RESTRAINT SYSTEM (SRS)

Description (Cont'd)

### PASSENGER AIR BAG DEACTIVATION SWITCH (KING CAB MODELS)

-NERS0009S03

The vehicle is equipped with a passenger air bag deactivation switch which can be operated by the customer. When the switch is turned to the ON position, the passenger air bag is enabled and could inflate in a frontal collision. When the switch is turned to the OFF position, the passenger air bag is disabled and will not inflate in a frontal collision.

After turning the ignition switch ON, the passenger air bag deactivation switch indicator on the instrument panel illuminates for bulb check. The indicator will remain illuminated if the passenger air bag deactivation switch is in the OFF position. If the passenger air bag deactivation switch is in the ON position, the indicator will turn off after about 7 seconds.

After SRS maintenance or repair, make sure the passenger air bag deactivation switch is in the same position (ON or OFF) as when the vehicle arrived for service.

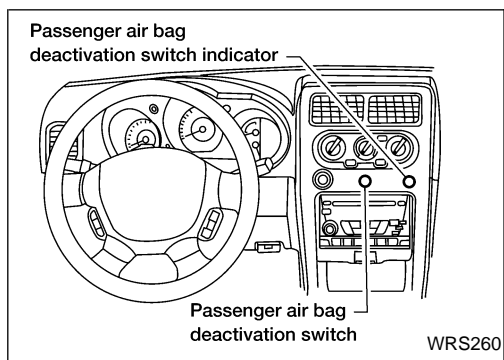

### IGN OFF → ON

NERS0009S0301

Passenger air bag deactivation switch position	Passenger air bag deactivation switch indicator	Passenger air bag deployment
ON	Turns off within 7 seconds	Enabled
OFF	Remains illuminated	Disabled



# SUPPLEMENTAL RESTRAINT SYSTEM (SRS)

SRS Component Parts Location

## SRS Component Parts Location

NEERS0010

SEC. 240 • 253 • 484 • 680

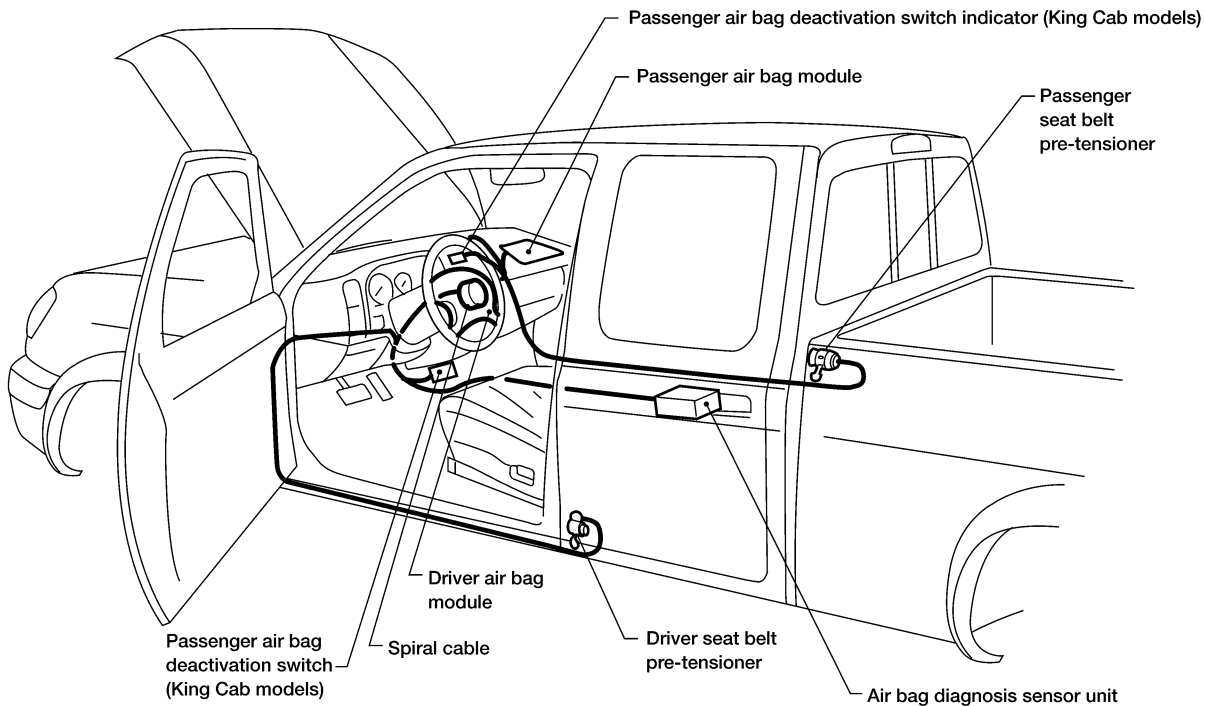

WRS232

### Diagnosis Sensor Unit REMOVAL AND INSTALLATION

NEERS0012

#### CAUTION:

- Before servicing SRS, turn the ignition switch off, disconnect both battery cables and wait for at least 3 minutes.
- The special bolts are coated with bonding agent while the other bolt is for ground. Do not reuse bolts after removal; replace with new ones.
- Check air bag diagnosis sensor unit for proper installation.
- Check air bag diagnosis sensor unit to ensure it is free of deformities, dents, cracks and rust. If there are any visible signs of damage, replace it with a new one.
- Check air bag diagnosis sensor unit brackets to ensure they are free of deformities or rust.
- Replace air bag diagnosis sensor unit if it has been dropped or has sustained an impact.
- After replacement, perform self-diagnosis for SRS. Refer to "SRS Operation Check", RS-42.

GI  
MA  
EM  
LC  
EC  
FE  
CL  
MT  
AT  
TF  
PD  
AX  
SU  
BR  
ST  
RS  
BT  
HA  
SC  
EL  
IDX

# SUPPLEMENTAL RESTRAINT SYSTEM (SRS)

## Diagnosis Sensor Unit (Cont'd)

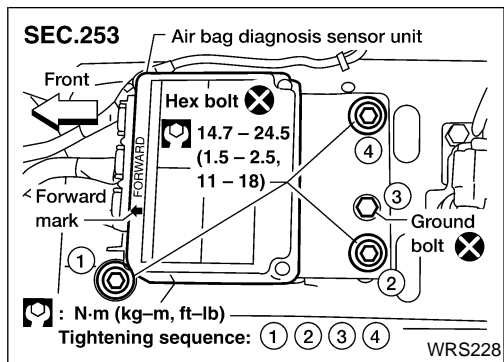

1. Disconnect driver and passenger air bag module connectors and seat belt pre-tensioner connectors.
2. Remove console box. Refer to **BT-20**, "INSTRUMENT PANEL ASSEMBLY".
3. Disconnect air bag diagnosis sensor unit connector.
4. Remove ground bolt and also remove special bolts from air bag diagnosis sensor unit. Then remove the air bag diagnosis sensor unit.

### NOTE:

- To install, reverse the removal procedure and tighten new bolts in the sequence indicated in the illustration.

### CAUTION:

Air bag diagnosis sensor unit must always be installed with forward mark "←" pointing toward the front of the vehicle for proper operation. Also check air bag diagnosis sensor unit for deformities, dents, cracks and rust before installation and replace as required.

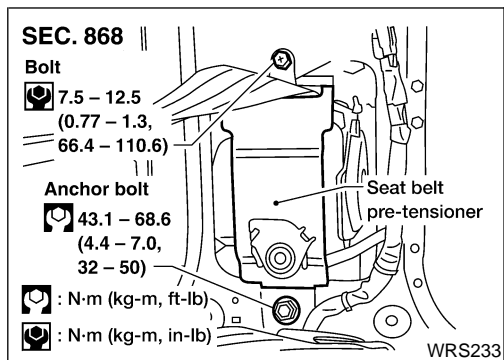

## Seat Belt Pre-tensioner REMOVAL AND INSTALLATION

NERS0040

### CAUTION:

- Before servicing SRS, turn the ignition switch OFF, disconnect both battery cables and wait at least 3 minutes.
- Do not use old bolts and nuts after removal; replace with new ones.
- Check seat belt pre-tensioner for proper installation.
- After replacement of seat belt pre-tensioner, check SRS function and perform self-diagnosis for SRS. Refer to "SRS Operation Check", RS-42.
- Do not attempt to disassemble air bag diagnosis sensor unit or seat belt pre-tensioner.
- Replace air bag diagnosis sensor unit or seat belt pre-tensioner if it has been dropped or sustained an impact.
- Do not expose seat belt pre-tensioner to temperatures exceeding 80°C (176°F).

For removal of seat belt pre-tensioner, refer to "Front Seat Belt", RS-5.

### NOTE:

To install, reverse removal procedure.

# SUPPLEMENTAL RESTRAINT SYSTEM (SRS)

Driver Air Bag Module and Spiral Cable

## Driver Air Bag Module and Spiral Cable

### REMOVAL AND INSTALLATION

NERS0013

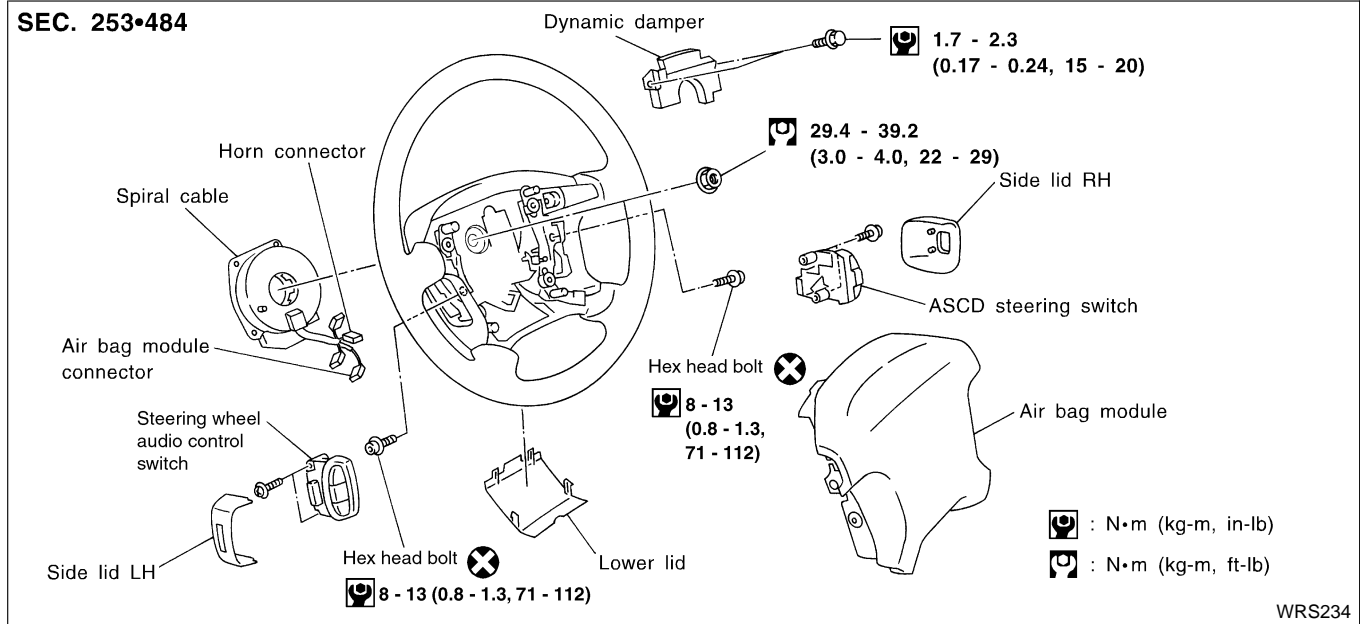

### REMOVAL

NERS0014

#### CAUTION:

- Before servicing SRS, turn the ignition switch OFF, disconnect both battery cables and wait at least 3 minutes.
- Always work from the side of an air bag module.

1. Remove side lids and/or switch covers and switches. Remove the hex bolts.

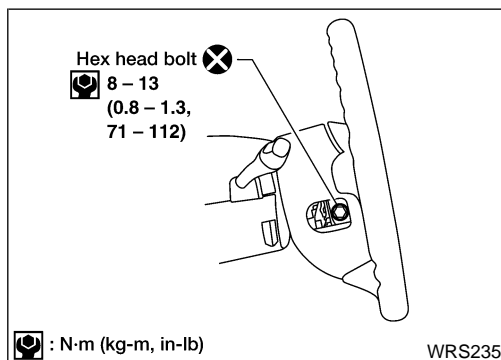

2. Lift driver air bag module out of the steering wheel slowly, releasing the connector at the back of the module by pulling out the black lock mechanism.

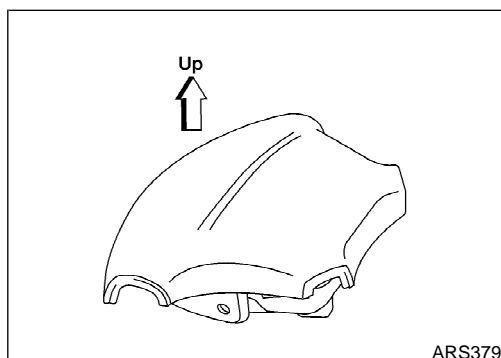

#### CAUTION:

- Always place air bag module with pad side facing upward.
- Do not attempt to disassemble air bag module.
- The special bolts are coated with bonding agent. Do not use old bolts after removal; replace with new ones.
- Do not insert any foreign objects (screwdriver, etc.) into air bag module connector.

GI  
MA  
EM  
LC  
EC  
FE  
CL  
MT  
AT  
TF  
PD  
AX  
SU  
BR  
ST  
RS  
BT  
HA  
SC  
EL  
IDX

## SUPPLEMENTAL RESTRAINT SYSTEM (SRS)

### Driver Air Bag Module and Spiral Cable (Cont'd)



- Do not drop or impact air bag module. If any portion is deformed or cracked, replace the module.
- Do not expose the air bag module to temperatures exceeding 90°C (194°F).
- Do not allow oil, grease or water to come in contact with the air bag module.

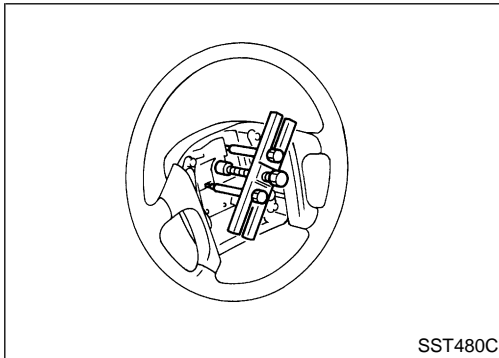

3. Set steering wheel in the neutral position.
4. Disconnect horn connector from steering wheel (floating horn bracket).
5. Release the spiral cable connectors from the steering wheel by sliding off the connector brackets and remove nut.
6. Using steering wheel puller, remove steering wheel. Be careful not to over-tighten puller bolt on steering wheel.

#### CAUTION:

- Do not tap or bump the steering wheel.
7. Remove steering column covers, instrument panel lower LH and knee protector.
  8. Disconnect spiral cable connector from air bag harness.

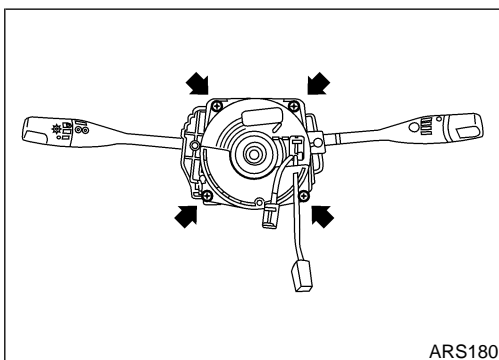

9. Remove the four spiral cable retaining screws. Remove the spiral cable.

#### CAUTION:

- Do not attempt to disassemble spiral cable.
- Do not apply lubricant to the spiral cable.

# SUPPLEMENTAL RESTRAINT SYSTEM (SRS)

Driver Air Bag Module and Spiral Cable (Cont'd)

NEERS0015

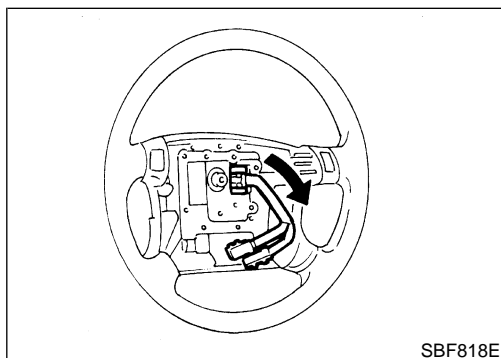
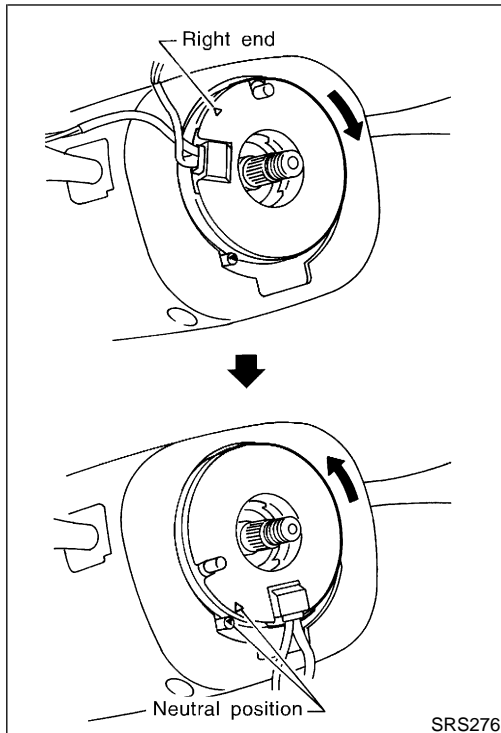
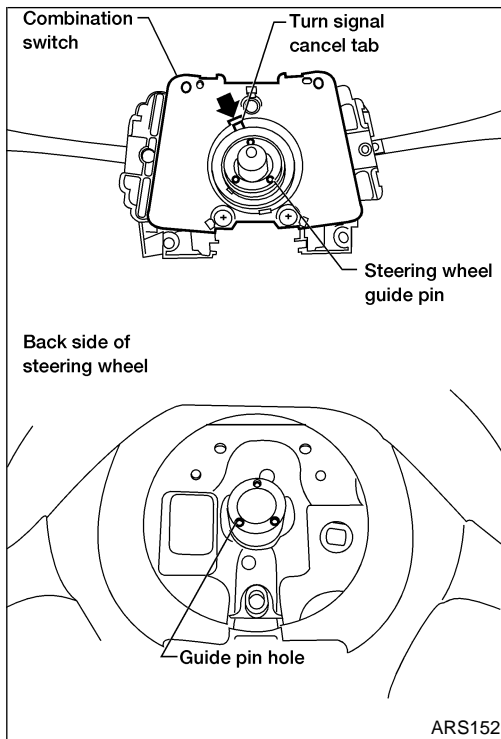

## INSTALLATION

1. Set the front wheels in the straight-ahead position.
2. Align the turn signal cancel tab with the notch of the combination switch as shown.

3. Rotate the spiral cable fully clockwise until tight.
4. Rotate the spiral cable counterclockwise approximately 2.25 turns and align white pin with arrow on housing.

- When the spiral cable is centered, white pin is aligned with arrow on housing and yellow wheel shows in window.

### CAUTION:

- The spiral cable may snap during steering operation if the spiral cable is installed in an improper position.
- Also, with the steering linkage disconnected, the cable may snap by turning the steering wheel beyond the limited number of turns. The spiral cable can be turned counterclockwise approximately 2.25 turns. Always perform SRS self-diagnosis after installing the air bag module. Refer to "SRS Operation Check", RS-42.

5. Connect spiral cable to air bag harness and tighten screws. Install steering column covers.

6. Install steering wheel, setting spiral cable pin guide, and pull spiral cable connectors through.
7. Install dynamic damper.
8. Tighten steering wheel nut.

 : 29 - 39 N·m (3.0 - 4.0 kg-m, 22 - 29 ft-lb)

9. Connect spiral cable connectors to floating horn bracket and attach to any switch connector brackets.
10. Attach spiral cable air bag connector to driver air bag module.

GI

MA

EM

LC

EC

FE

CL

MT

AT

TF

PD

AX

SU

BR

ST

RS

BT

HA

SC

EL

IDX

# SUPPLEMENTAL RESTRAINT SYSTEM (SRS)

## Driver Air Bag Module and Spiral Cable (Cont'd)

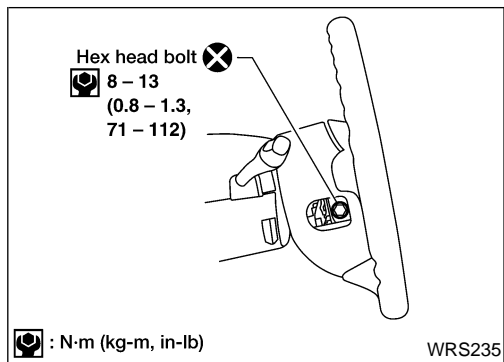

11. Position driver air bag module and install two new hex head bolts.
12. Install any switches.
13. Install all lids.
14. Connect both battery cables.
15. Conduct self-diagnosis to ensure entire SRS operates properly. (Use CONSULT-II or "AIR BAG" warning lamp check.) Turn the steering wheel fully to the right and left to check that the spiral cable is set in the neutral position.
16. If "AIR BAG" warning lamp blinks (in User mode), it shows the spiral cable may be snapped due to its improper position. Perform Self-diagnosis again. (Use CONSULT-II or "AIR BAG" warning lamp check.) If a malfunction is detected, replace the spiral cable with a new one.

### NOTE:

- After replacement, perform self-diagnosis for SRS. Refer to "SRS Operation Check", RS-42.

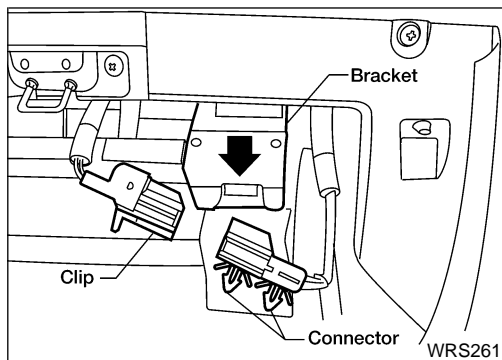

## Front Passenger Air Bag Module

### REMOVAL

NERS0016

#### CAUTION:

- Before servicing SRS, turn the ignition switch OFF, disconnect both battery cables and wait for at least 3 minutes.
  - Always work from the side of an air bag module.
1. Open glove box assembly.
  2. Reach up and bend down deformable connector bracket assembly.
  3. Remove passenger air bag module connector clip from bracket.
  4. Disconnect passenger air bag module connector from air bag harness connector.
  5. Remove glove box. Refer to **BT-20**, "INSTRUMENT PANEL ASSEMBLY".

# SUPPLEMENTAL RESTRAINT SYSTEM (SRS)

Front Passenger Air Bag Module (Cont'd)

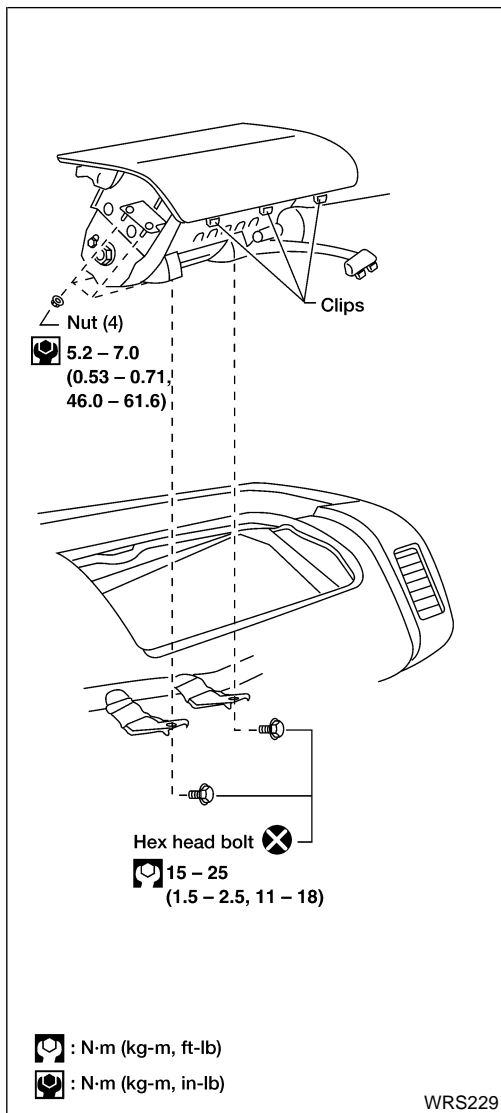

6. Remove two hex head bolts.
  7. Remove four mounting nuts.
  8. Remove passenger air bag module by releasing the clips from the top of the instrument panel.
- **The air bag module is heavy and should be supported using both hands during removal.**

GI

MA

EM

LC

EC

FE

CL

MT

AT

TF

PD

AX

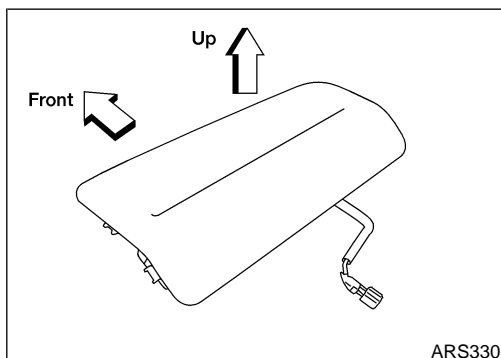

## CAUTION:

- Always place air bag module with pad side facing upward.
- Do not attempt to disassemble air bag module.
- Do not use old bolts after removal; replace with new bolts.
- Do not insert any foreign objects (screwdriver, etc.) into air bag module connector.

SU

BR

ST

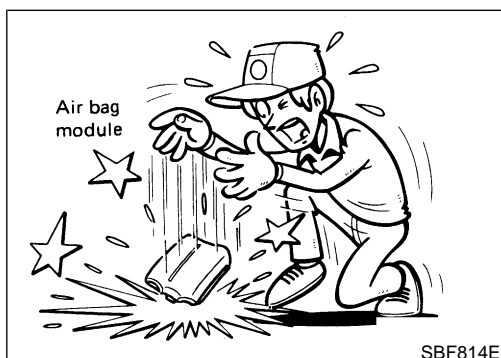

- Do not drop or impact air bag module. If any portion is deformed or cracked, replace the module.
- Do not expose the air bag module to temperatures exceeding 90°C (194°F).
- Do not allow oil, grease or water to come in contact with the air bag module.
- After air bag inflates, the instrument panel assembly should be replaced if damaged.

RS

BT

HA

SC

EL

IDX

# SUPPLEMENTAL RESTRAINT SYSTEM (SRS)

## Front Passenger Air Bag Module (Cont'd)

NEERS0017

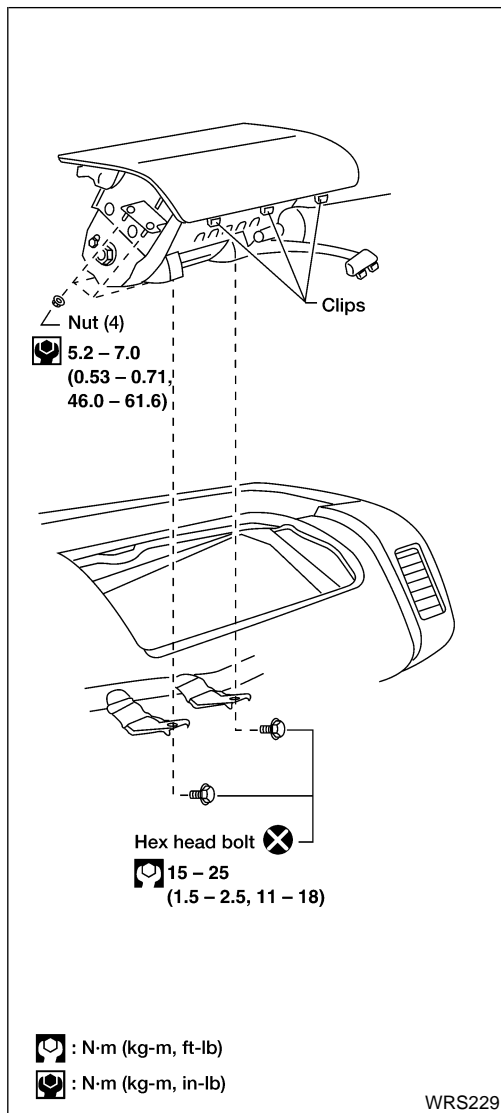

## INSTALLATION

### CAUTION:

- Always work from the side of an air bag module.
1. Install passenger air bag module in instrument panel.
    - 1) Insert front edge of passenger air bag module first to ease installation.
  - Ensure harness is not caught between passenger air bag module and support bracket.
  - 2) Install four mounting nuts.
  - 3) Install two new hex head bolts.
  2. Install glove box. Refer to **BT-20**, "INSTRUMENT PANEL ASSEMBLY".

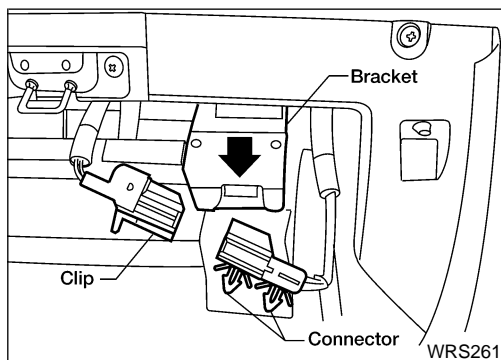

3. Connect air bag harness connector to passenger air bag module harness connector.
4. Attach passenger air bag module connector clip to bracket (Bracket in down position).
5. Bend bracket up clear of glove box and close glove box.
6. Connect both battery cables.
7. Conduct self-diagnosis to ensure entire SRS operates properly. (Use CONSULT-II or "AIR BAG" warning lamp check.)

### NOTE:

- After replacement, perform self-diagnosis for SRS. Refer to "SRS Operation Check", RS-42.



# SUPPLEMENTAL RESTRAINT SYSTEM (SRS)

Passenger Air Bag Deactivation Switch

## Passenger Air Bag Deactivation Switch REMOVAL

=NERS0046

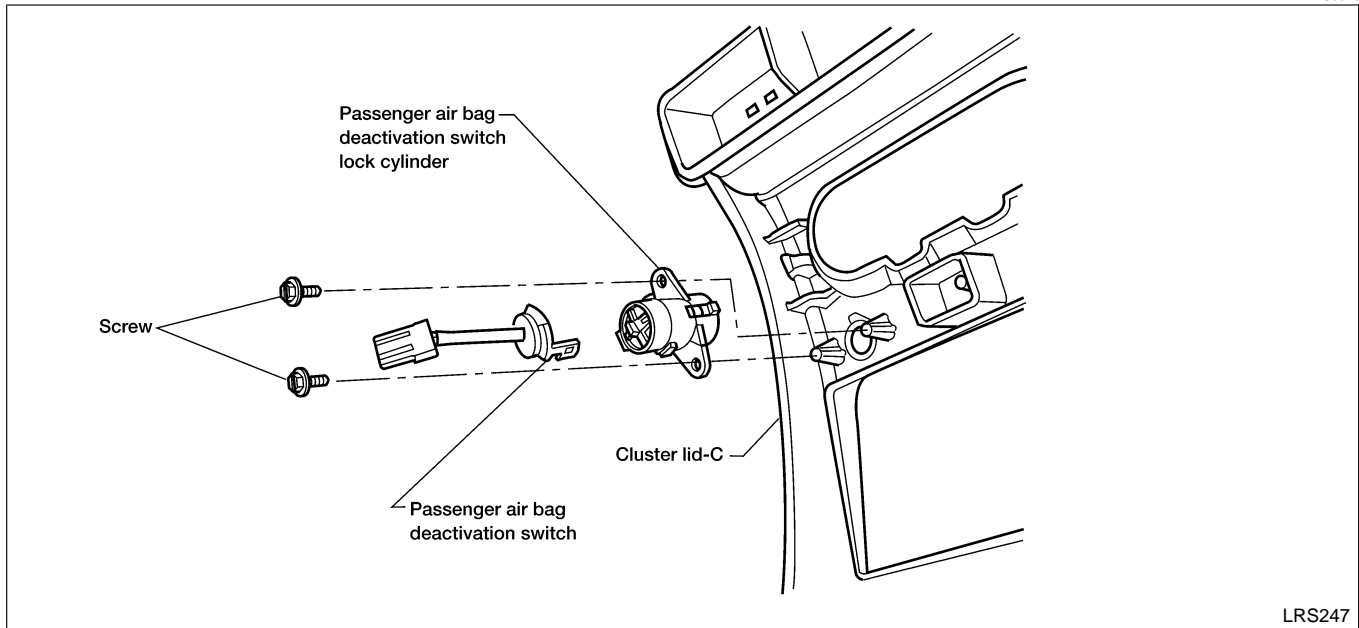

LRS247

- Before servicing SRS, turn the ignition switch OFF, disconnect both battery cables and wait for at least 3 minutes.
1. Remove cluster lid-C. Refer to **BT-20**, "Removal and Installation".
  2. Disengage the two locking tabs from the passenger air bag deactivation switch lock cylinder and remove passenger air bag deactivation switch.

### INSTALLATION

NERS0047

#### **CAUTION:**

Passenger air bag deactivation switch is keyed for proper installation. Improper positioning of the switch will result in damage to the switch.

#### **NOTE:**

- Be sure that the passenger air bag deactivation switch and lock cylinder is connected and in the same position as during removal for proper engagement.
- To install, reverse removal procedure.
- After replacement, perform self-diagnosis for SRS. Refer to "SRS Operation Check", RS-42.

GI

MA

EM

LC

EC

FE

CL

MT

AT

TF

PD

AX

SU

BR

ST

RS

BT

HA

SC

EL

IDX

# SUPPLEMENTAL RESTRAINT SYSTEM (SRS)

Passenger Air Bag Deactivation Switch Lock Cylinder

## Passenger Air Bag Deactivation Switch Lock Cylinder REMOVAL

=NERS0048

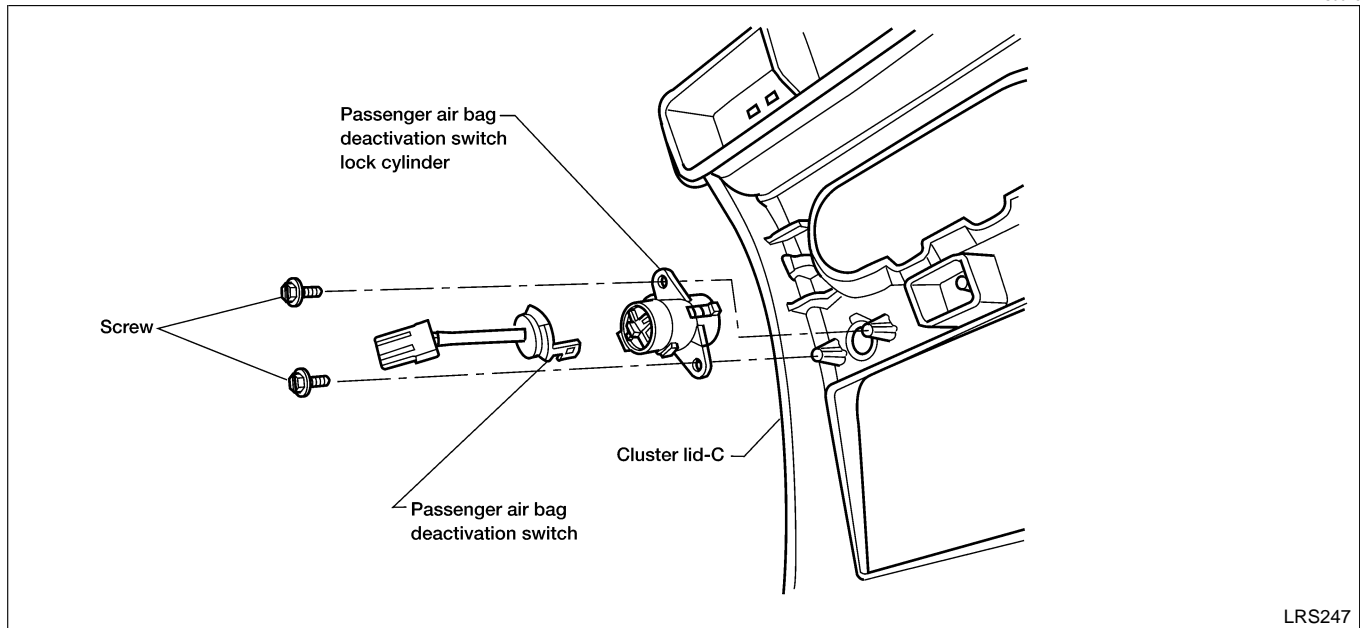

LRS247

- Before servicing SRS, turn ignition switch OFF, disconnect both battery cables and wait for at least 3 minutes.
1. Remove cluster lid-C. Refer to **BT-20**, "Removal and Installation".
  2. Disengage the two locking tabs from the passenger air bag deactivation switch lock cylinder and remove the passenger air bag deactivation switch.
  3. Remove two retaining screws from the cluster lid-C and remove the passenger air bag deactivation switch lock cylinder.

## INSTALLATION

NERS0049

### NOTE:

- Be sure that the passenger air bag deactivation switch and lock cylinder is connected and in the same position as during removal for proper engagement.
- To install, reverse removal procedure.
- After replacement, perform self-diagnosis for SRS. Refer to "SRS Operation Check", RS-42.

# SUPPLEMENTAL RESTRAINT SYSTEM (SRS)

Passenger Air Bag Deactivation Switch Indicator

## Passenger Air Bag Deactivation Switch Indicator REMOVAL

=NERS0050

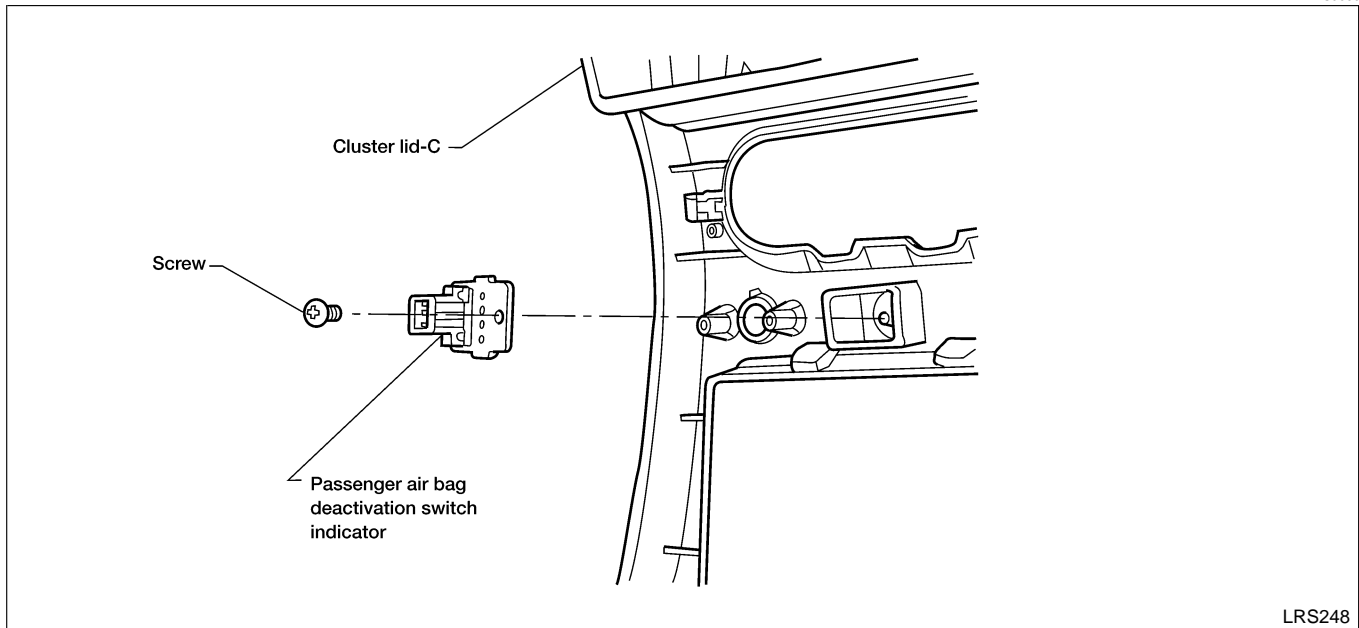

- Before servicing SRS, turn ignition switch OFF, disconnect both battery cables and wait for at least 3 minutes.

1. Remove cluster lid-C. Refer to **BT-20**, "Removal and Installation".
2. Remove one screw and remove passenger air bag deactivation switch indicator.

### INSTALLATION

#### NOTE:

NERS0051

- To install, reverse removal procedure.
- After replacement, perform self-diagnosis for SRS. Refer to "SRS Operation Check", RS-42.

### Disposal of Air Bag Module and Seat Belt Pre-tensioner

NERS0018

- Before disposing of air bag modules and seat belt pretensioners, or vehicles equipped with such systems, deploy the systems. If such systems have already been deployed due to an accident, dispose of as indicated in "DISPOSING OF AIR BAG MODULE AND SEAT BELT PRE-TENSIONER", RS-33.
- When deploying air bag module or seat belt pre-tensioner, always use the Special Service Tool; Deployment tool KV99106400 (Kent-Moore No. J38381).
- When deploying air bag module or seat belt pre-tensioner,

RS-27

GI

MA

EM

LC

EC

FE

CL

MT

LRS248

AT

TF

PD

AX

SU

BR

ST

RS

BT

HA

SC

EL

IDX

# SUPPLEMENTAL RESTRAINT SYSTEM (SRS)

## Disposal of Air Bag Module and Seat Belt Pre-tensioner (Cont'd)

stand at least 5 m (16 ft) away from the deployment component.

- When deploying air bag module or seat belt pre-tensioner, a fairly loud noise is made, followed by smoke being released. The smoke is not poisonous, however, be careful not to inhale smoke as it irritates the throat and can cause choking.
- Only activate one air bag module or seat belt pre-tensioner at a time.
- Due to heat, leave air bag module unattended for more than 30 minutes after deployment. Leave seat belt pre-tensioner unattended for more than 10 minutes after deployment.
- Be sure to wear gloves when handling a deployed air bag module or seat belt pre-tensioner.
- Never apply water to a deployed air bag module or seat belt pre-tensioner.
- Wash your hands clean after finishing work.
- Place the vehicle outdoors with an open space of at least 6 m (20 ft) on all sides when deploying air bag module or seat belt pre-tensioner while mounted in vehicle.
- Use a voltmeter to make sure the vehicle battery is fully charged.
- Do not dispose of the air bag module or seat belt pre-tensioner un-deployed.

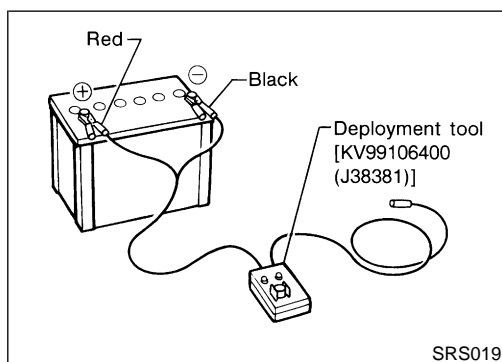

### CHECKING DEPLOYMENT TOOL

#### Connecting to Battery

NERS0018S01

NERS0018S0101

#### **CAUTION:**

**The battery must show voltage of 9.6V or more.**

Remove the battery from the vehicle and place it on dry wood blocks approximately 5 m (16 ft) away from the vehicle.

- Wait 3 minutes after the vehicle battery is disconnected before proceeding.
- Connect red clip of deployment tool [SST: KV99106400 (J38381)] to battery positive terminal and black clip to negative terminal.

#### **CAUTION:**

**Make sure the polarity is correct. The right side lamp on the deployment tool [SST: KV99106400 (J38381)], marked "DEPLOYMENT TOOL POWER", should glow with a green light. If the right side lamp glows red, reverse the connections to the battery.**

# SUPPLEMENTAL RESTRAINT SYSTEM (SRS)

Disposal of Air Bag Module and Seat Belt Pre-tensioner (Cont'd)

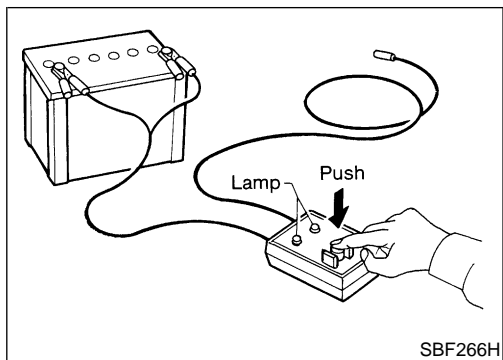

## Deployment Tool Check

NERS0018S0102

Press the deployment tool [SST: KV99106400 (J38381)] switch to the ON position. The left side lamp on the deployment tool [SST: KV99106400 (J38381)], marked "AIR BAG CONNECTOR VOLTAGE", should illuminate. If it does not illuminate, replace the tool.

## Air Bag Deployment Tool Lamp Illumination Chart (Battery connected)

NERS0018S0103

Switch operation	Left side lamp, green* "AIR BAG CONNECTOR VOLTAGE"	Right side lamp, green* "DEPLOYMENT TOOL POWER"
OFF	OFF	ON
ON	ON	ON

\*: If this lamp glows red, the tool is connected to the battery incorrectly. Reverse the connections and make sure the lamp glows green.

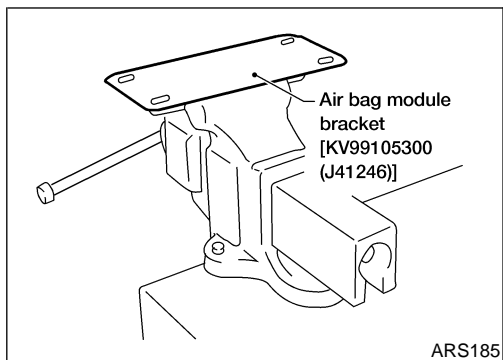

## DEPLOYMENT PROCEDURES FOR AIR BAG MODULE (OUTSIDE OF VEHICLE)

NERS0018S02

Unless the vehicle is being scrapped, deploying the air bag modules in the vehicle is not recommended. This may cause damage to the vehicle interior.

Anchor air bag module bracket [KV99105300 (J41246)] in a vise secured to a firm foundation during deployment.

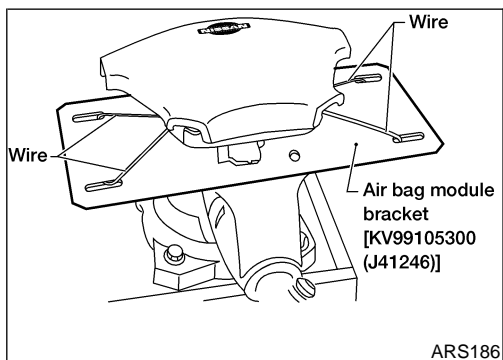

## Deployment of Driver Air Bag Module (Outside of vehicle)

NERS0018S0201

- Using wire, secure driver air bag module to air bag module bracket [SST: KV99105300 (J41246)] at two places.

### CAUTION:

If a gap exists between driver air bag module and air bag module bracket, use a piece of wood inserted in the gap to stabilize the air bag module.

Use wire of at least 1 mm (0.04 in) diameter.

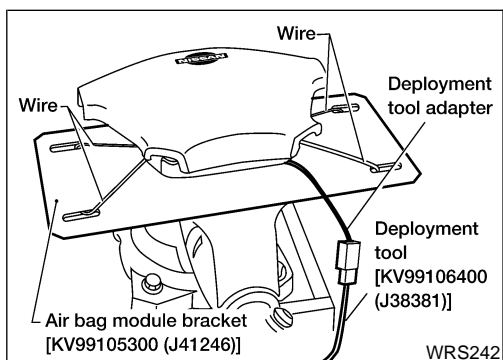

- Firmly secure air bag module bracket [SST: KV99105300 (J41246)] with driver air bag module attached, in a vise.
- Connect deployment tool adapter [SST: KV99109000 (J44230)] to deployment tool [SST: KV99106400 (J38381)] and driver air bag module connector.
- Connect red clip of deployment tool [SST: KV99106400 (J38381)] to battery positive terminal and black clip to negative terminal.
- The right side lamp on the deployment tool [SST: KV99106400 (J38381)], marked "DEPLOYMENT TOOL POWER", should glow green, not red.
- Press the button on the deployment tool [SST: KV99106400 (J38381)]. The left side lamp on the deployment tool [SST: KV99106400 (J38381)] should glow green.

GI  
MA  
EM  
LC  
EC  
FE  
CL  
MT  
AT  
TF  
PD  
AX  
SU  
BR  
ST  
RS  
BT  
HA  
SC  
EL  
IDX

# SUPPLEMENTAL RESTRAINT SYSTEM (SRS)

Disposal of Air Bag Module and Seat Belt Pre-tensioner (Cont'd)

KV99106400 (J38381)], marked "AIR BAG CONNECTOR VOLTAGE", will illuminate and the air bag module will deploy.

**CAUTION:**

**When deploying the air bag module, stand at least 5 m (16 ft) away from the air bag module.**

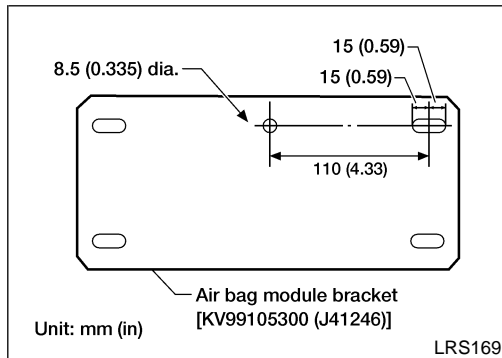

## Deployment of Passenger Air Bag Module (Outside of vehicle)

NERS0018S0202

1. Make an 8.5 mm (0.335 in) diameter hole in air bag module bracket [SST: KV99105300 (J41246)] at the position shown in figure at left.

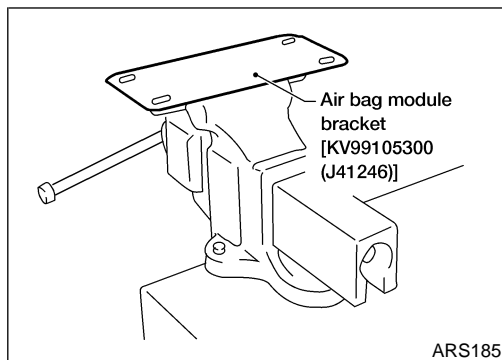

2. Firmly secure air bag module bracket [SST: KV99105300 (J41246)] in a vise.

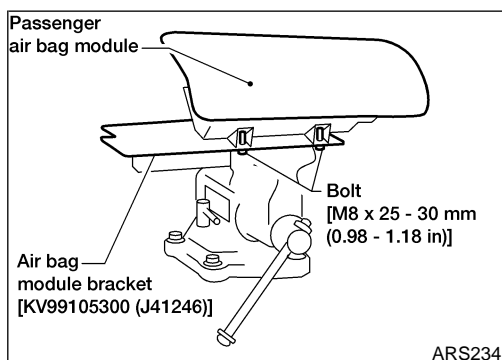

3. Match the two holes in air bag module bracket [SST: KV99105300 (J41246)] (held in vise) and passenger air bag module and fix them with two bolts [M8 x 25 - 30 mm (0.98 - 1.18 in)].

**CAUTION:**

**If a gap exists between passenger air bag module and air bag module bracket, use a piece of wood inserted in the gap to stabilize the air bag module.**

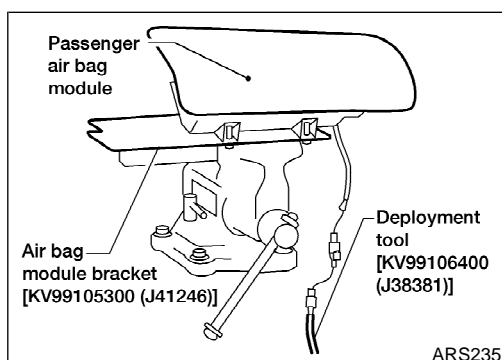

4. Connect deployment tool adapter [SST: KV991065S0 (J38381-30)] to deployment tool [SST: KV99106400 (J38381)] connector and passenger air bag module connector.

## SUPPLEMENTAL RESTRAINT SYSTEM (SRS)

*Disposal of Air Bag Module and Seat Belt Pre-tensioner (Cont'd)*

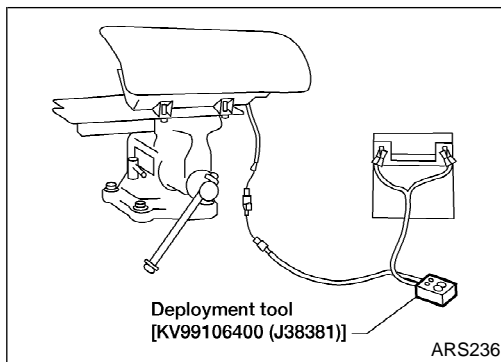

5. Connect red clip of deployment tool [SST: KV99106400 (J38381)] to battery positive terminal and black clip to negative terminal.
6. The right side lamp on the deployment tool [SST: KV99106400 (J38381)], marked "DEPLOYMENT TOOL POWER", should glow green, not red.
7. Press the button on the deployment tool [SST: KV99106400 (J38381)]. The left side lamp on the deployment tool [SST: KV99106400 (J38381)], marked "AIR BAG CONNECTOR VOLTAGE", will illuminate and the air bag module will deploy.

### CAUTION:

- When deploying the air bag module, stand at least 5 m (16 ft) away from the air bag module.

GI  
MA  
EM  
LC  
EC  
FE  
CL  
MT  
AT  
TF  
PD  
AX  
SU  
BR  
ST  
RS  
BT  
HA  
SC  
EL  
IDX

# SUPPLEMENTAL RESTRAINT SYSTEM (SRS)

Disposal of Air Bag Module and Seat Belt Pre-tensioner (Cont'd)

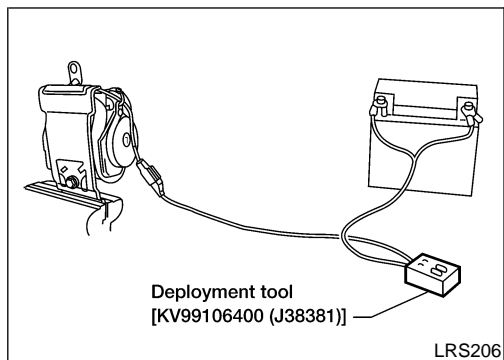
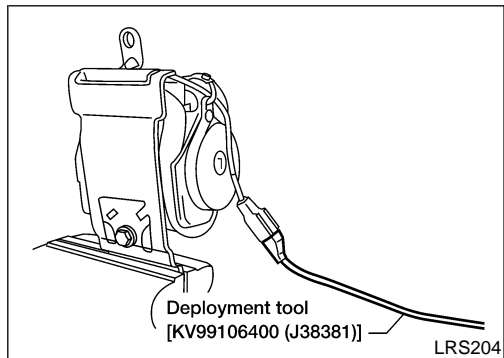
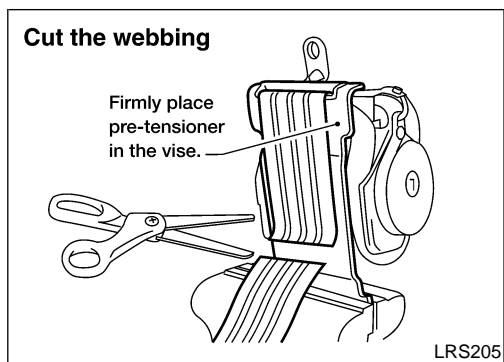

## Deployment of Seat Belt Pre-tensioner (Outside of vehicle)

=NERS0018S0203

1. Firmly anchor seat belt pre-tensioner in a vise, then cut webbing off.
2. Connect deployment tool [SST: KV99106400 (J38381)] connector to seat belt pre-tensioner connector.
  - Use deployment tool adapter [SST: KV99109000 (J44230)] for pre-tensioners that have a built in harness lead.
3. Connect red clip of deployment tool [SST: KV99106400 (J38381)] to battery positive terminal and black clip to negative terminal.
4. The right side lamp on the deployment tool [SST: KV99106400 (J38381)], marked "DEPLOYMENT TOOL POWER", should glow green, not red.
5. Press the button on the deployment tool [SST: KV99106400 (J38381)]. The left side lamp on the deployment tool [SST: KV99106400 (J38381)], marked "AIR BAG CONNECTOR VOLTAGE", will illuminate and the seat belt pre-tensioner will deploy.

### CAUTION:

- When deploying the seat belt pre-tensioner, stand at least 5 m (16 ft) away from the seat belt pre-tensioner.



# SUPPLEMENTAL RESTRAINT SYSTEM (SRS)

Disposal of Air Bag Module and Seat Belt Pre-tensioner (Cont'd)

## DEPLOYMENT OF AIR BAG MODULE AND SEAT BELT PRE-TENSIONER WHILE MOUNTED IN VEHICLE

When disposing of a vehicle, deploy air bag modules and seat belt pre-tensioners while they are mounted in vehicle. =NERS0018S03

### CAUTION:

When deploying air bag module or seat belt pre-tensioner, ensure vehicle is empty.

1. Disconnect both battery cables and wait 3 minutes.
2. Disconnect air bag module connector or seat belt pre-tensioner connector.
3. Remove air bag module from steering wheel, disconnecting spiral cable from air bag module.
4. Connect deployment tool [SST: KV99106400 (SST: J38381)] to air bag module and reattach module with side bolts.  
For passenger air bag module, use deployment tool adapter [SST: KV991065S0 (J38381-30)] to attach air bag module to deployment tool [SST: KV99106400 (J38381)] connector. For driver air bag module, use deployment tool adapter [SST: KV99109000 (J44230)] to attach air bag module to deployment tool [SST: KV99106400 (J38381)] connector.

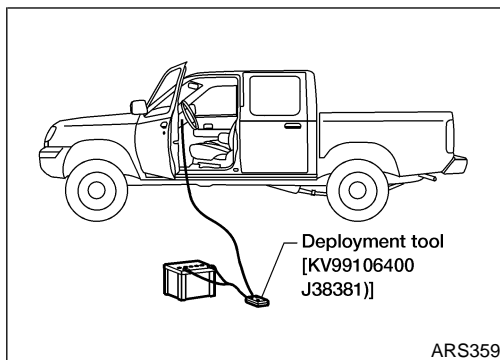

5. Connect red clip of deployment tool [SST: KV99106400 (J38381)] to battery positive terminal and black clip to negative terminal.
6. The right side lamp on the deployment tool [SST: KV99106400 (J38381)], marked "DEPLOYMENT TOOL POWER", should glow green, not red.
7. Press the button on the deployment tool [SST: KV99106400 (J38381)]. The left side lamp on the deployment tool [SST: KV99106400 (J38381)], marked "AIR BAG CONNECTOR VOLTAGE", will illuminate and the air bag module or seat belt pre-tensioner will deploy.

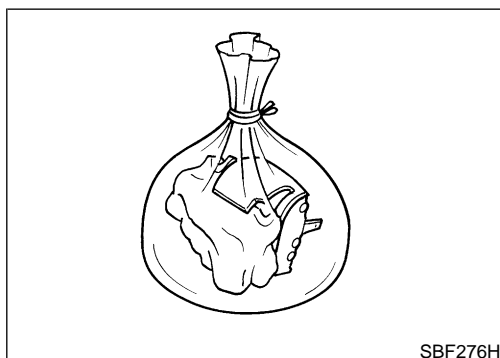

## DISPOSING OF AIR BAG MODULE AND SEAT BELT PRE-TENSIONER

Deployed air bag modules and seat belt pre-tensioners are very hot. Before disposing of air bag modules and seat belt pre-tensioners, wait at least 30 minutes and 10 minutes, respectively. Seal them in a plastic bag before disposal. NERS0018S04

### CAUTION:

- Never apply water to a deployed air bag module or seat belt pre-tensioner.
- Be sure to wear gloves when handling a deployed air bag module or seat belt pre-tensioner.
- No poisonous gas is produced upon air bag module or seat belt pre-tensioner deployment. However, be careful not to inhale gas since it irritates the throat and can cause choking.
- Do not attempt to disassemble air bag module or seat belt pre-tensioner.
- Air bag module or seat belt pre-tensioner cannot be reused.
- Wash your hands clean after finishing work.

# SUPPLEMENTAL RESTRAINT SYSTEM (SRS)

## Trouble Diagnoses Introduction

=NERS0030

### CAUTION:

- Do not use electrical test equipment on any circuit related to the SRS unless instructed to in this Service Manual. SRS wiring harnesses can be identified by yellow harness connectors.
- Do not attempt to repair, splice or modify the SRS wiring harness. If the harness is damaged, replace it with a new one.
- Keep ground portion clean.

### DIAGNOSIS FUNCTION

NERS0030S01

The SRS self-diagnosis results can be read by using “AIR BAG” warning lamp and/or CONSULT-II. The reading of these results is accomplished using one of two modes — “User mode” and “Diagnosis mode”.

The User mode is exclusively prepared for the customer (driver). This mode warns the driver of a system malfunction through the operation of the “AIR BAG” warning lamp.

The Diagnosis mode allows the technician to locate and inspect the malfunctioning part.

The mode applications for the “AIR BAG” warning lamp and CONSULT-II are as follows:

	User mode	Diagnosis mode	Display type
“AIR BAG” warning lamp	X	X	ON-OFF operation
CONSULT-II	—	X	Monitoring

### NOTE:

Seat belt pre-tensioner malfunction is indicated by “AIR BAG” warning lamp.

### DIAGNOSIS MODE FOR CONSULT-II

NERS0030S02

- “SELF-DIAG [CURRENT]”  
A current Self-diagnosis result (also indicated by the number of warning lamp flashes in the Diagnosis mode) is displayed on the CONSULT-II screen in real time. This refers to a malfunctioning part requiring repairs.
- “SELF-DIAG [PAST]”  
Diagnosis results previously stored in the memory are displayed on the CONSULT-II screen. The stored results are not erased until memory erasing is executed.
- “TROUBLE DIAG RECORD”  
With TROUBLE DIAG RECORD, diagnosis results previously erased by a reset operation can be displayed on the CONSULT-II screen.
- “ECU DISCRIMINATED NO.”  
The diagnosis sensor unit for each vehicle model is assigned with its own, individual classification number. This number will be displayed on the CONSULT-II screen, as shown. When replacing the diagnosis sensor unit, refer to the part number for the compatibility. After installation, replacement with a correct unit can be checked by confirming this classification number on the CONSULT-II screen.

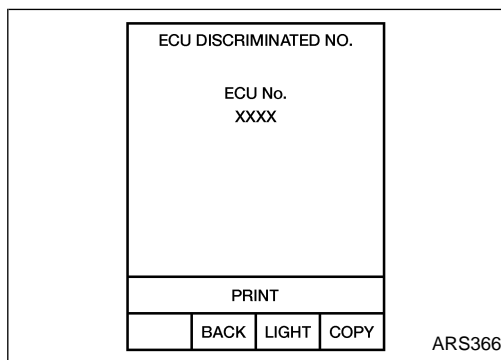

Model	ECU Part No.	ECU Discriminated No.
King Cab	28556 8Z300	A60C
Crew Cab	28556 8Z500	A60D

# SUPPLEMENTAL RESTRAINT SYSTEM (SRS)

Trouble Diagnoses Introduction (Cont'd)

## ① HOW TO CHANGE SELF-DIAGNOSIS MODE WITH CONSULT-II

-NERS0030S03

### From User Mode to Diagnosis Mode

NERS0030S0301

After selecting "AIR BAG" on the "SELECT SYSTEM" screen, User mode automatically changes to Diagnosis mode.

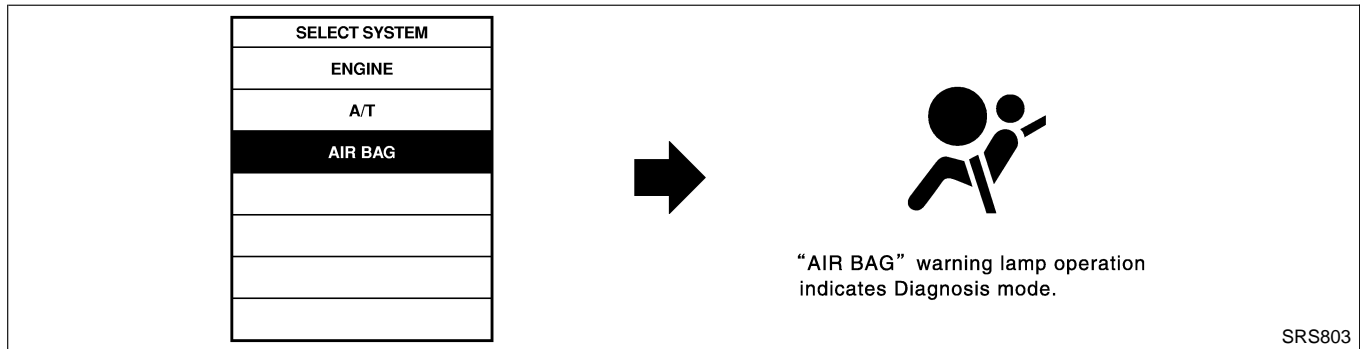

### From Diagnosis Mode to User Mode

NERS0030S0303

To return to User mode from Diagnosis mode, touch "BACK" key of CONSULT-II until "SELECT SYSTEM" appears, Diagnosis mode automatically changes to User mode.

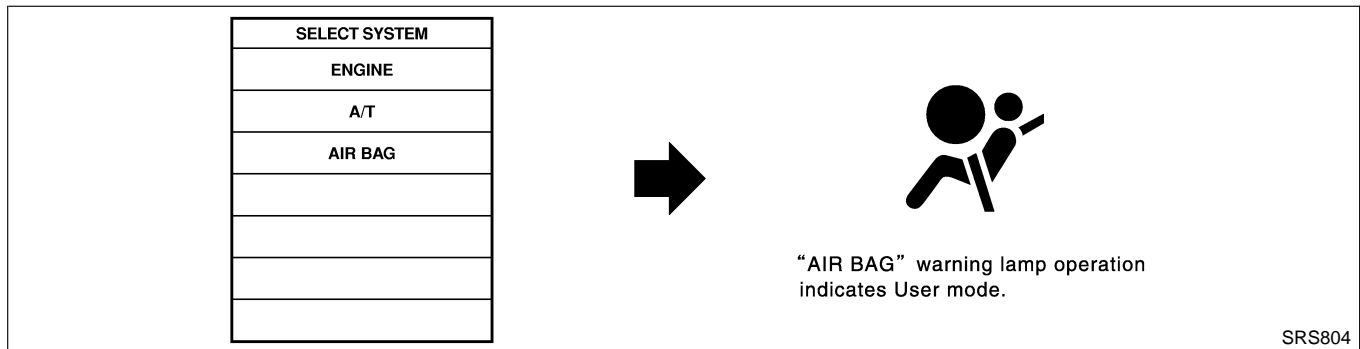

## ⊗ HOW TO CHANGE SELF-DIAGNOSIS MODE WITHOUT CONSULT-II

NERS0030S05

### From User Mode to Diagnosis Mode

NERS0030S0501

Diagnosis mode activates only when a malfunction is detected, by turning ignition switch as follows:

- 1) Turn ignition switch "ON".
- 2) After "AIR BAG" warning lamp lights for 7 seconds, turn ignition switch "OFF" within 1 second.
- 3) Wait more than 3 seconds.
- 4) Repeat steps 1 to 3 three times.
- 5) Turn ignition switch "ON".

SRS will not enter Diagnosis mode if no malfunction is detected.

### From Diagnosis Mode to User Mode

NERS0030S0502

After a malfunction is repaired, switch the ignition "OFF" for at least one second, then back "ON". Diagnosis mode is returned to User mode.

If switching Diagnosis mode to User mode is required while malfunction is being detected, by turning ignition switch as follows:

- 1) Turn ignition switch "ON".
- 2) After "AIR BAG" warning lamp lights for 7 seconds, turn ignition switch "OFF" within 1 second.
- 3) Wait more than 3 seconds.
- 4) Repeat steps 1 to 3 three times.
- 5) Turn ignition switch "ON".

GI  
MA  
EM  
LC  
EC  
FE  
CL  
MT  
AT  
TF  
PD  
AX  
SU  
BR  
ST  
RS  
BT  
HA  
SC  
EL  
IDX

# SUPPLEMENTAL RESTRAINT SYSTEM (SRS)

Trouble Diagnoses Introduction (Cont'd)

## HOW TO ERASE SELF-DIAGNOSIS RESULTS

=NERS0030S04

NERS0030S0401

### ④ With CONSULT-II

- “SELF-DIAG [CURRENT]”  
A current self-diagnosis result is displayed on the CONSULT-II screen in real time.  
After the malfunction is repaired completely, no malfunction is detected on “SELF-DIAG [CURRENT]”.
- “SELF-DIAG [PAST]”  
Return to the “SELF-DIAG [CURRENT]” CONSULT-II screen by pushing “BACK” key of CONSULT-II and select “SELF-DIAG [CURRENT]” in SELECT DIAG MODE. Touch “ERASE” in “SELF-DIAG [CURRENT]” mode.

### NOTE:

If the memory of the malfunction in “SELF-DIAG [PAST]” is not erased, the User mode shows the system malfunction by the operation of the warning lamp even if the malfunction is repaired completely.

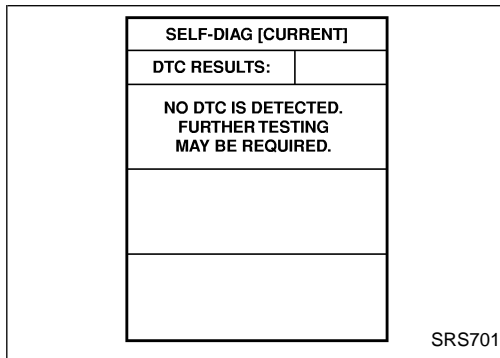

- “TROUBLE DIAG RECORD”  
The memory of “TROUBLE DIAG RECORD” cannot be erased.

### ⊗ Without CONSULT-II

NERS0030S0402

After a malfunction is repaired, switch the ignition “OFF” for at least one second, then back “ON”. Diagnosis mode returns to the User mode. At that time, the self-diagnostic result is cleared.

# SUPPLEMENTAL RESTRAINT SYSTEM (SRS)

*How to Perform Trouble Diagnoses for Quick and Accurate Repair*

## How to Perform Trouble Diagnoses for Quick and Accurate Repair

A good understanding of the malfunction conditions can make troubleshooting faster and more accurate. In general, each customer feels differently about a malfunction. It is important to fully understand the symptoms or conditions for a customer complaint.

### INFORMATION FROM CUSTOMER

WHAT ..... Vehicle model

WHEN ..... Date, Frequencies

WHERE ..... Road conditions

HOW ..... Operating conditions, Symptoms

### PRELIMINARY CHECK

Check that the following parts are in good order.

- Battery, refer to **SC-4**, "BATTERY"
- Fuse
- System component-to-harness connections

=NERS0031

GI

MA

NERS0031S01

EM

LC

NERS0031S02

EC

FE

CL

MT

AT

TF

PD

AX

SU

BR

ST

**RS**

BT

HA

SC

EL

IDX

# SUPPLEMENTAL RESTRAINT SYSTEM (SRS)

How to Perform Trouble Diagnoses for Quick and Accurate Repair (Cont'd)

## WORK FLOW

=NERS0031S03

### NOTE:

Seat belt pre-tensioner malfunction is indicated by "AIR BAG" warning lamp.

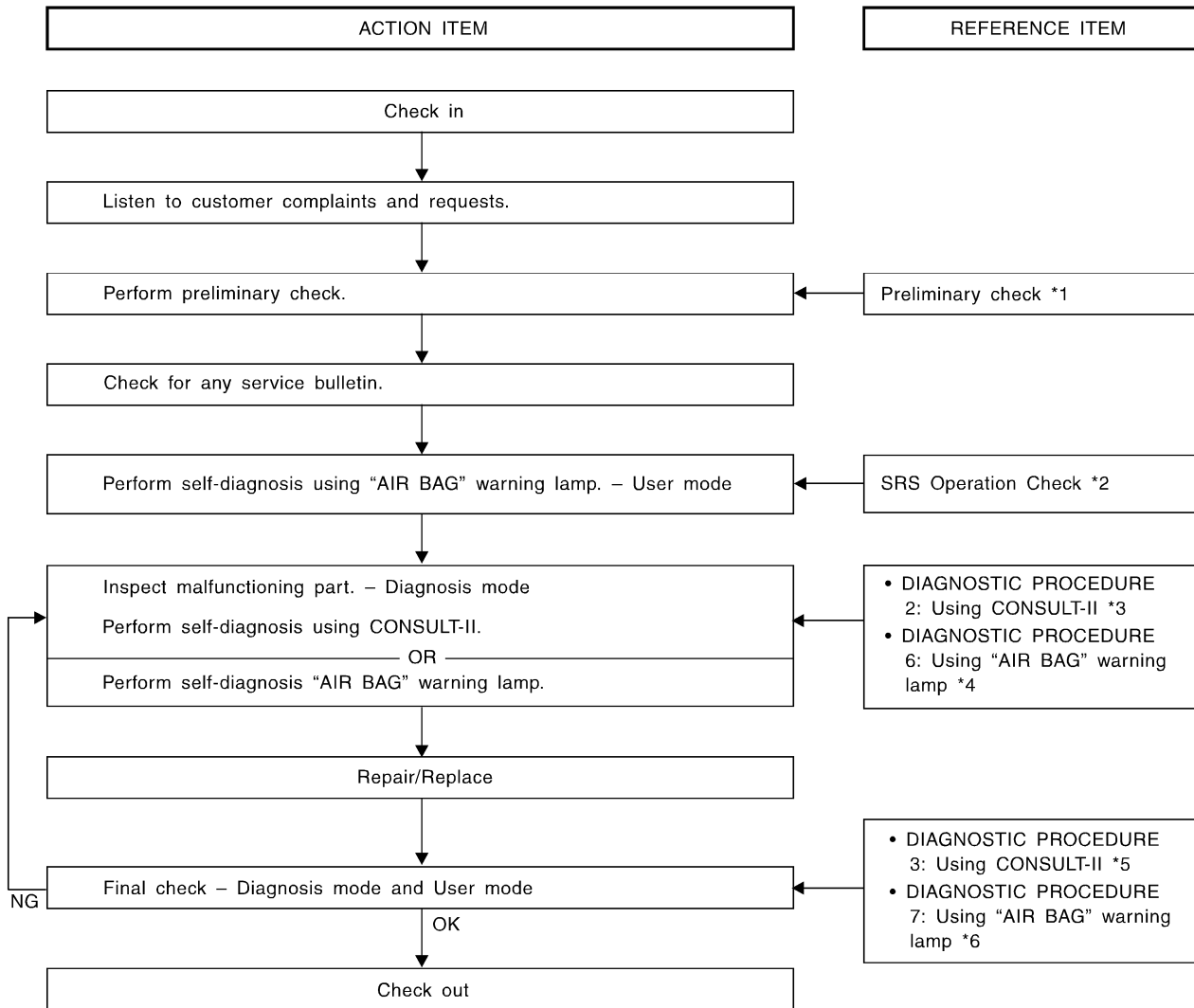

SRS799

\*1: RS-37  
\*2: RS-42

\*3: RS-42  
\*4: RS-53

\*5: RS-47  
\*6: RS-57

# SUPPLEMENTAL RESTRAINT SYSTEM (SRS)

Wiring Diagram — SRS —

## Wiring Diagram — SRS —

NER50021

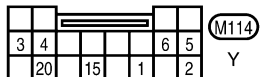
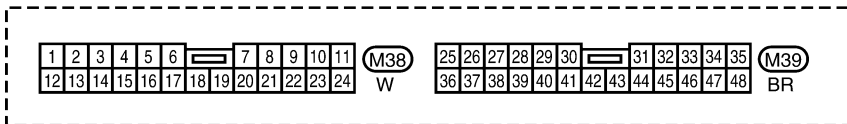
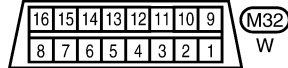
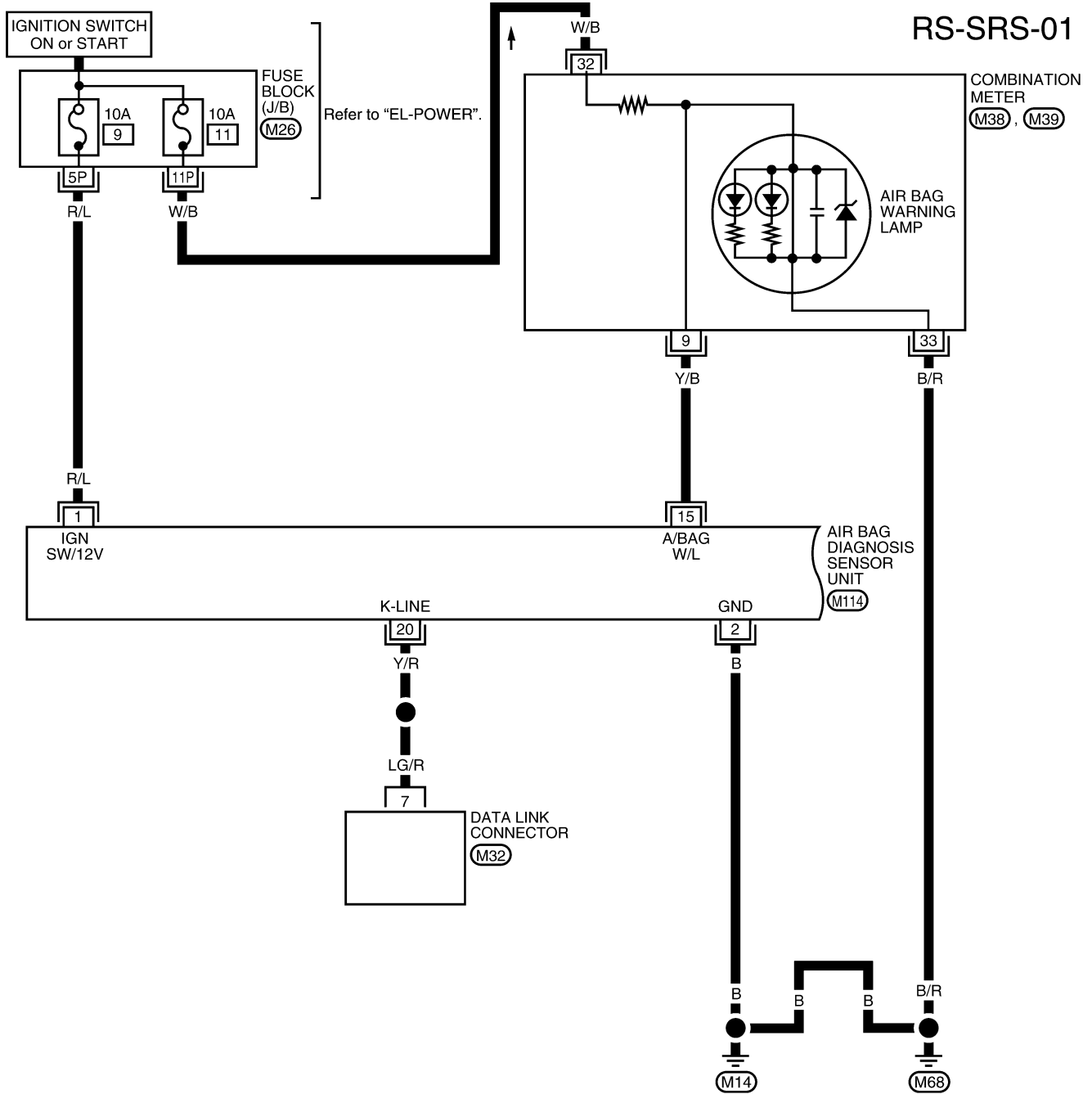

GI  
MA  
EM  
LC  
EC  
FE  
CL  
MT  
AT  
TF  
PD  
AX  
SU  
BR  
ST

**RS**

BT

HA

SC

EL

IDX

WRS221

# SUPPLEMENTAL RESTRAINT SYSTEM (SRS)

Wiring Diagram — SRS — (Cont'd)

RS-SRS-02

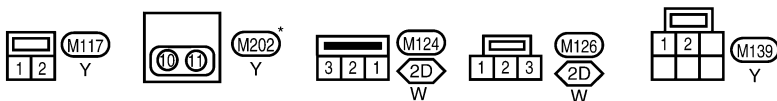
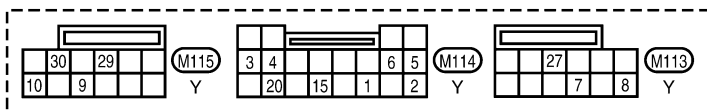
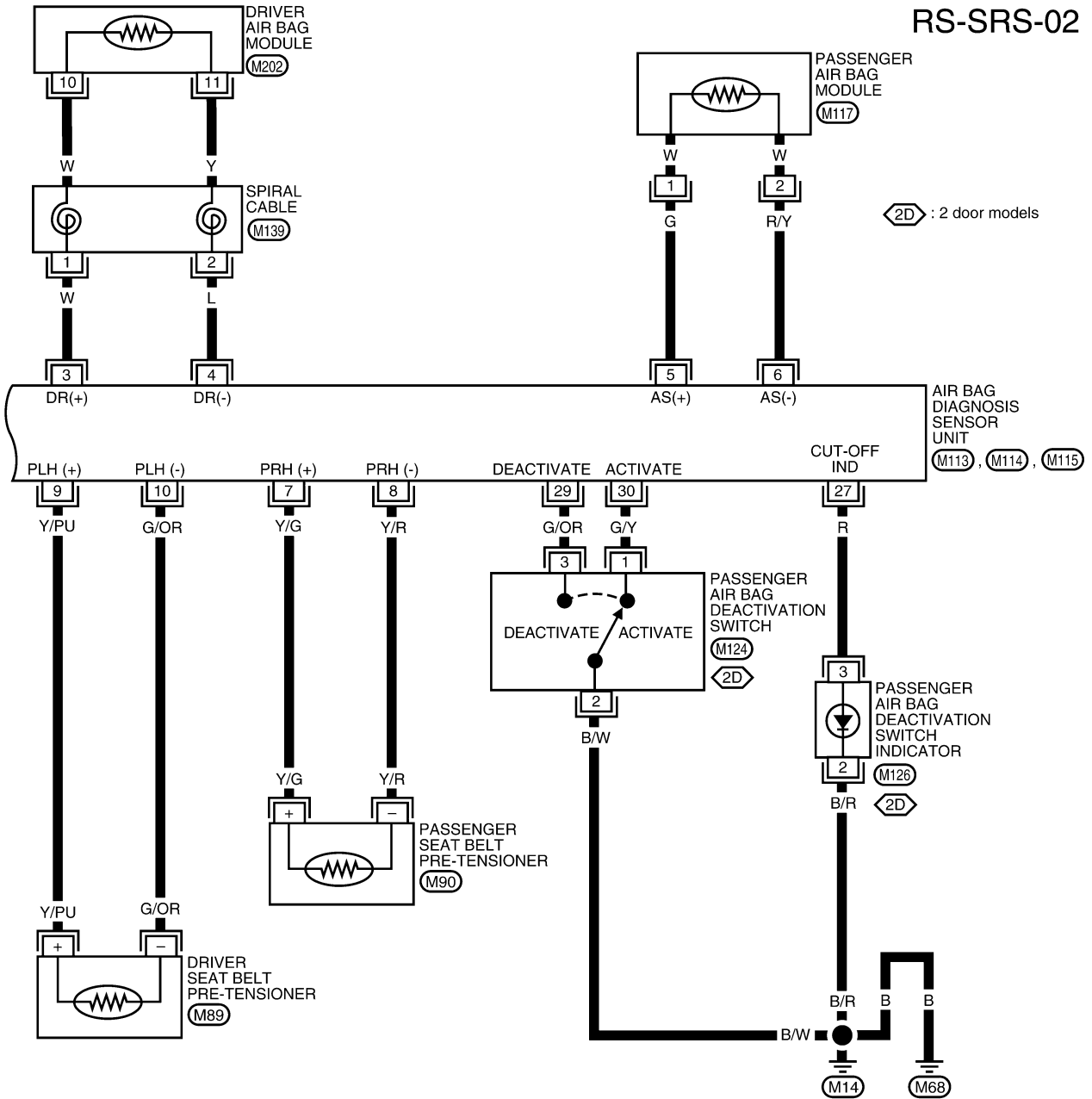

\* : This connector is not shown in "HARNESS LAYOUT" of EL section.

WRS222



# SUPPLEMENTAL RESTRAINT SYSTEM (SRS)

Passenger Air Bag Deactivation Switch Indicator Operation Check

## Passenger Air Bag Deactivation Switch Indicator Operation Check

NEERS0052

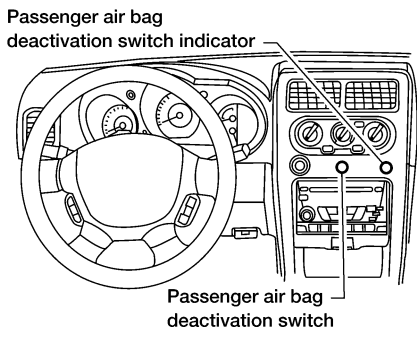
<b>1</b>	<b>INDICATOR OPERATION CHECK</b>							
<p>Check passenger air bag deactivation switch indicator operation when turning ignition switch ON with passenger air bag deactivation switch in ON and OFF positions.</p> <div style="text-align: center;">  </div> <p style="text-align: right;">WRS260</p> <table border="1" style="margin: 20px auto;"> <thead> <tr> <th>Passenger air bag deactivation switch position</th> <th>Passenger air bag deactivation switch indicator</th> </tr> </thead> <tbody> <tr> <td style="text-align: center;">ON</td> <td style="text-align: center;">Turns off within 7 seconds</td> </tr> <tr> <td style="text-align: center;">OFF</td> <td style="text-align: center;">Remains illuminated</td> </tr> </tbody> </table> <p style="text-align: right;">ARS365</p> <p style="text-align: center;"><b>OK or NG</b></p>			Passenger air bag deactivation switch position	Passenger air bag deactivation switch indicator	ON	Turns off within 7 seconds	OFF	Remains illuminated
Passenger air bag deactivation switch position	Passenger air bag deactivation switch indicator							
ON	Turns off within 7 seconds							
OFF	Remains illuminated							
OK	▶	Passenger air bag deactivation switch indicator operation is OK. Conduct "SRS Operation Check". Refer to "SRS Operation Check", RS-42.						
NG	▶	GO TO 2.						

<b>2</b>	<b>PERFORM SELF-DIAGNOSIS</b>	
<p>Perform self-diagnosis using "AIR BAG" warning lamp in User mode. Refer to "SRS Operation Check", RS-42.</p> <p><b>NOTE:</b>  <b>The passenger air bag deactivation switch indicator can only be self-diagnosed when a malfunction occurs and indicator illumination does not correspond to switch position.</b></p> <p style="text-align: center;"><b>OK or NG</b></p>		
OK	▶	Replace passenger air bag deactivation including the key cylinder. Conduct "Passenger Air Bag Deactivation Switch Indicator Operation Check" as a final check.
NG	▶	Perform self-diagnosis using CONSULT-II or "AIR BAG" warning lamp in Diagnosis mode. Refer to "SRS Operation Check", RS-42 or "DIAGNOSTIC PROCEDURE 6", RS-53 respectively. If the passenger air bag deactivation switch indicator remains illuminated with the passenger air bag deactivation switch ON, leave passenger air bag deactivation switch in ON position during diagnosis. If the passenger air bag deactivation switch indicator does not illuminate with the passenger air bag deactivation switch OFF, leave the passenger air bag deactivation switch in the OFF position during diagnosis.

GI  
MA  
EM  
LC  
EC  
FE  
CL  
MT  
AT  
TF  
PD  
AX  
SU  
BR  
ST  
RS  
BT  
HA  
SC  
EL  
IDX

# SUPPLEMENTAL RESTRAINT SYSTEM (SRS)

## SRS Operation Check

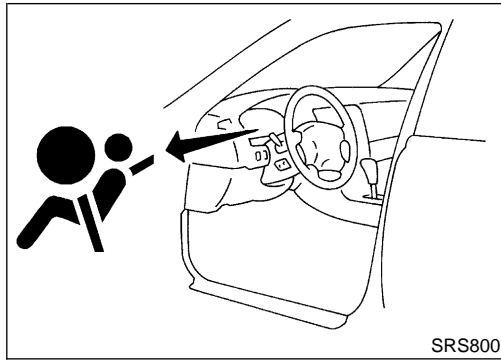

### SRS Operation Check DIAGNOSTIC PROCEDURE 1 Checking Air Bag Operation by Using “AIR BAG” Warning Lamp — User Mode

NERS0022

NERS0022S01

NERS0022S0101

1. After turning ignition switch from “OFF” to “ON”, “AIR BAG” warning lamp operates.
2. Compare “AIR BAG” warning lamp operation to the chart below.

“AIR BAG” warning lamp operation — User mode —	SRS condition	Reference item
<p>MRS095A</p>	No malfunction is detected. No further action is necessary.	—
<p>MRS096A</p>	The system is malfunctioning and needs to be repaired as indicated.	Go to “DIAGNOSTIC PROCEDURE 2”, RS-42 or “DIAGNOSTIC PROCEDURE 6” RS-53.
<p>MRS097A</p>	Air bag is deployed. Seat belt pre-tensioner is deployed.	Go to “Collision Diagnosis”, RS-61.
<p>MRS098A</p>	Air bag fuse, diagnosis sensor unit or harness is malfunctioning and needs to be repaired.	Go to “DIAGNOSTIC PROCEDURE 9”, RS-59.
<p>MRS098A</p>	One of the following has occurred and needs to be repaired. <ul style="list-style-type: none"> <li>• Meter fuse is blown.</li> <li>• “AIR BAG” warning lamp circuit has open or short.</li> <li>• Diagnosis sensor unit is malfunctioning.</li> </ul>	Go to “DIAGNOSTIC PROCEDURE 10”, RS-61.

### Ⓜ Trouble Diagnoses with CONSULT-II DIAGNOSTIC PROCEDURE 2 Inspecting SRS malfunctioning parts by using CONSULT-II — Diagnosis mode

NERS0023

NERS0023S01

1. Turn ignition switch “OFF”.
2. Connect CONSULT-II to data link connector.

# SUPPLEMENTAL RESTRAINT SYSTEM (SRS)

④ Trouble Diagnoses with CONSULT-II (Cont'd)

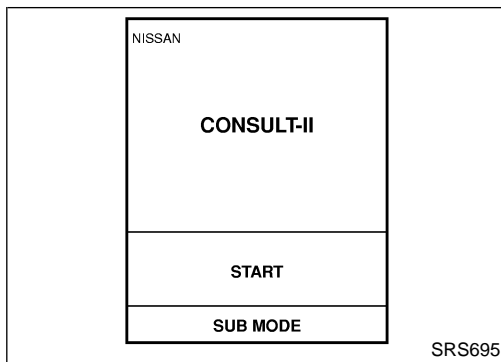

3. Turn ignition switch "ON".
4. Touch "START".

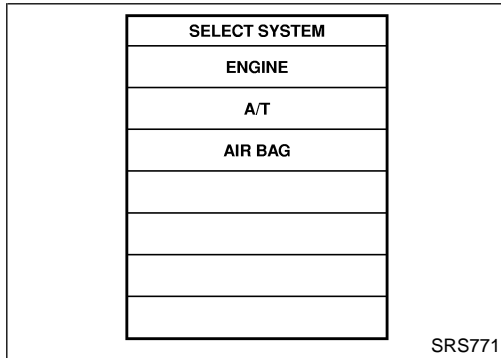

5. Touch "AIR BAG".

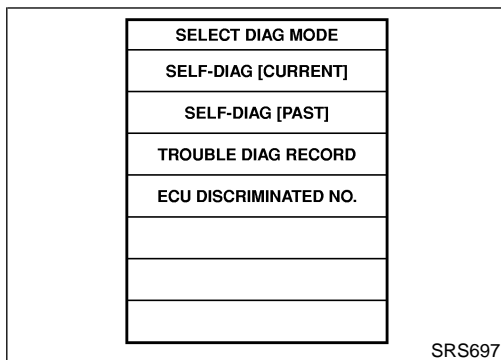

6. Touch "SELF-DIAG [CURRENT]".

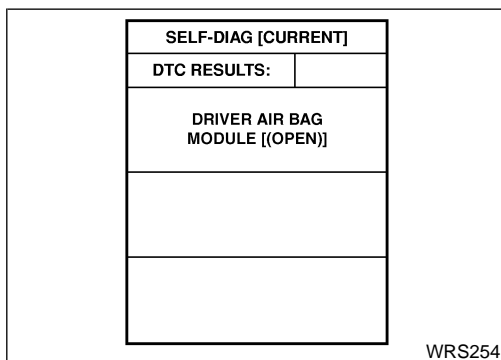

7. Diagnostic codes are displayed on "SELF-DIAG [CURRENT]".

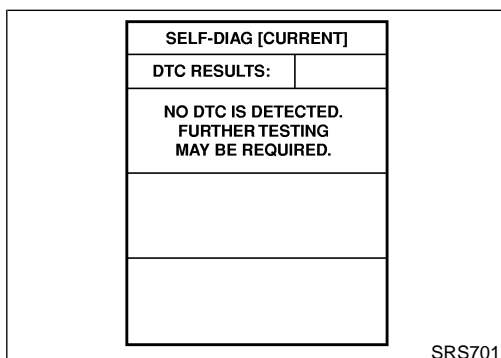

If no malfunction is detected on "SELF-DIAG [CURRENT]" even though malfunction is detected in "SRS Operation Check", check the battery voltage.

If the battery voltage is less than 9V, charge the battery. Then go to "DIAGNOSTIC PROCEDURE 3", RS-47.

If the battery voltage is OK, refer to "DIAGNOSTIC PROCEDURE 4 (CONTINUE FROM DIAGNOSTIC PROCEDURE 2)", RS-48, to diagnose the following cases:

- Self-diagnostic result "SELF-DIAG [PAST]" (previously stored in the memory) might not be erased after repair.
- The SRS system malfunctions intermittently.

GI  
MA  
EM  
LC  
EC  
FE  
CL  
MT  
AT  
TF  
PD  
AX  
SU  
BR  
ST  
RS  
BT  
HA  
SC  
EL  
IDX

## SUPPLEMENTAL RESTRAINT SYSTEM (SRS)

 Trouble Diagnoses with CONSULT-II (Cont'd)

---

8. Touch "COPY".
9. Compare diagnostic codes to "CONSULT-II Diagnostic Code Chart". Refer to "CONSULT-II Diagnostic Code Chart ('SELF-DIAG [CURRENT]')", RS-45.
10. Touch "BACK" key of CONSULT-II until "SELECT SYSTEM" appears in order to return to User mode from Diagnosis mode.
11. Turn ignition switch "OFF", then turn off and disconnect CONSULT-II, and disconnect both battery cables.
12. Repair the system as outlined by the "Repair order" in "CONSULT-II Diagnostic Code Chart", that corresponds to the self-diagnostic result. For replacement procedure of component parts, refer to the applicable Removal and Installation procedure.
13. After repairing the system, refer to "DIAGNOSTIC PROCEDURE 3", RS-47 for final checking.

# SUPPLEMENTAL RESTRAINT SYSTEM (SRS)

Trouble Diagnoses with CONSULT-II (Cont'd)

## CONSULT-II Diagnostic Code Chart ("SELF-DIAG [CURRENT]")

=NERS0023S0101

Self-diagnosis result	Explanation		Repair order **"Recheck SRS at each replacement."
NO DTC IS DETECTED.	When malfunction is indicated by the "AIR BAG" warning lamp in User mode	<ul style="list-style-type: none"> <li>• Low battery voltage (Less than 9V)</li> <li>• Self-diagnosis result " SELF-DIAG [PAST]" (previously stored in the memory) might not have been erased after repair.</li> <li>• Intermittent malfunction has been detected in the past.</li> </ul>	<ul style="list-style-type: none"> <li>• Go to "DIAGNOSTIC PROCEDURE 3", RS-47 after charging battery.</li> <li>• Go to "DIAGNOSTIC PROCEDURE 4", RS-48.</li> </ul>
	<ul style="list-style-type: none"> <li>• No malfunction is detected.</li> </ul>		<ul style="list-style-type: none"> <li>• Go to "DIAGNOSTIC PROCEDURE 3", RS-47.</li> </ul>
DRIVER AIRBAG MODULE [OPEN]	<ul style="list-style-type: none"> <li>• Driver air bag module circuit is open (including the spiral cable).</li> </ul>		<ol style="list-style-type: none"> <li>1. Visually check wiring harness connections.</li> <li>2. Replace harness if it has visible damage.</li> </ol>
DRIVER AIRBAG MODULE [VB-SHORT]	<ul style="list-style-type: none"> <li>• Driver air bag module circuit is shorted to some power supply circuit (including the spiral cable).</li> </ul>		<ol style="list-style-type: none"> <li>3. Replace spiral cable.</li> <li>4. Replace driver air bag module. (Before disposing of it, it must be deployed.)</li> </ol>
DRIVER AIRBAG MODULE [GND-SHORT]	<ul style="list-style-type: none"> <li>• Driver air bag module circuit is shorted to ground (including the spiral cable).</li> </ul>		<ol style="list-style-type: none"> <li>5. Replace air bag diagnosis sensor unit.</li> <li>6. Replace the related harness.</li> </ol>
DRIVER AIRBAG MODULE [SHORT]	<ul style="list-style-type: none"> <li>• Driver air bag module circuits are shorted to each other.</li> </ul>		
ASSIST A/B MODULE [OPEN]	<ul style="list-style-type: none"> <li>• Passenger air bag module circuit is open.</li> </ul>		<ol style="list-style-type: none"> <li>1. Visually check wiring harness connections.</li> <li>2. Replace harness if it has visible damage.</li> </ol>
ASSIST A/B MODULE [VB-SHORT]	<ul style="list-style-type: none"> <li>• Passenger air bag module circuit is shorted to some power supply circuit.</li> </ul>		<ol style="list-style-type: none"> <li>3. Replace passenger air bag module. (Before disposing of it, it must be deployed.)</li> </ol>
ASSIST A/B MODULE [GND-SHORT]	<ul style="list-style-type: none"> <li>• Passenger air bag module circuit is shorted to ground.</li> </ul>		<ol style="list-style-type: none"> <li>4. Replace air bag diagnosis sensor unit.</li> </ol>
ASSIST A/B MODULE [SHORT]	<ul style="list-style-type: none"> <li>• Passenger air bag module circuits are shorted to each other.</li> </ul>		<ol style="list-style-type: none"> <li>5. Replace the related harness.</li> </ol>
PRE-TEN FRONT LH [OPEN]	<ul style="list-style-type: none"> <li>• The circuit for the driver seat belt pre-tensioner is open.</li> </ul>		<ol style="list-style-type: none"> <li>1. Visually check wiring harness connections.</li> <li>2. Replace harness if it has visible damage.</li> </ol>
PRE-TEN FRONT LH [VB-SHORT]	<ul style="list-style-type: none"> <li>• The circuit for the driver seat belt pre-tensioner is shorted to some power supply circuit.</li> </ul>		<ol style="list-style-type: none"> <li>3. Replace the driver's seat belt. (Before disposing of it, it must be deployed.)</li> </ol>
PRE-TEN FRONT LH [GND-SHORT]	<ul style="list-style-type: none"> <li>• The circuit for the driver seat belt pre-tensioner is shorted to ground.</li> </ul>		<ol style="list-style-type: none"> <li>4. Replace air bag diagnosis sensor unit.</li> <li>5. Replace the related harness.</li> </ol>
PRE-TEN FRONT RH [OPEN]	<ul style="list-style-type: none"> <li>• The circuit for the passenger seat belt pre-tensioner is open.</li> </ul>		<ol style="list-style-type: none"> <li>1. Visually check wiring harness connections.</li> <li>2. Replace harness if it has visible damage.</li> </ol>
PRE-TEN FRONT RH [VB-SHORT]	<ul style="list-style-type: none"> <li>• The circuit for the passenger seat belt pre-tensioner is shorted to some power supply circuit.</li> </ul>		<ol style="list-style-type: none"> <li>3. Replace the front passenger's seat belt. (Before disposing of it, it must be deployed.)</li> </ol>
PRE-TEN FRONT RH [GND-SHORT]	<ul style="list-style-type: none"> <li>• The circuit for the passenger seat belt pre-tensioner is shorted to ground.</li> </ul>		<ol style="list-style-type: none"> <li>4. Replace air bag diagnosis sensor unit.</li> <li>5. Replace the related harness.</li> </ol>

GI

MA

EM

LC

EC

FE

CL

MT

AT

TF

PD

AX

SU

BR

ST

RS

BT

HA

SC

EL

IDX

## SUPPLEMENTAL RESTRAINT SYSTEM (SRS)

 Trouble Diagnoses with CONSULT-II (Cont'd)

Self-diagnosis result	Explanation	Repair order **“Recheck SRS at each replacement.”
CONTROL UNIT	<ul style="list-style-type: none"> <li>● Air bag diagnosis sensor unit is malfunctioning.</li> </ul>	<ol style="list-style-type: none"> <li>1. Visually check wiring harness connections.</li> <li>2. Replace harness if it has visible damage.</li> <li>3. Replace air bag diagnosis sensor unit.</li> <li>4. Replace the related harness.</li> </ol>
Code B4 or PASS A/B DEACT SW	<ul style="list-style-type: none"> <li>● Activate terminal is open.</li> </ul>	<ol style="list-style-type: none"> <li>1. Visually check wiring harness connections.</li> <li>2. Replace harness if it has visible damage.</li> <li>3. Replace passenger air bag deactivation switch. (The key cylinder of passenger air bag deactivation switch does not have to be replaced.)</li> <li>4. Replace air bag diagnosis sensor unit.</li> <li>5. Replace the related harness.</li> </ol>
	<ul style="list-style-type: none"> <li>● Activate terminal is shorted to ground.</li> </ul>	
	<ul style="list-style-type: none"> <li>● Deactivate terminal is open.</li> </ul>	
	<ul style="list-style-type: none"> <li>● Deactivate terminal is shorted to ground.</li> </ul>	
	<ul style="list-style-type: none"> <li>● Activate terminal and deactivate terminal are shorted to each other.</li> </ul>	
Code B5 or PASS A/B DEACT SW INDICATOR	<ul style="list-style-type: none"> <li>● Passenger air bag deactivation switch indicator circuit is open.</li> </ul>	<ol style="list-style-type: none"> <li>1. Visually check wiring harness connections.</li> <li>2. Replace harness if it has visible damage.</li> <li>3. Replace passenger air bag deactivation switch indicator.</li> <li>4. Replace air bag diagnosis sensor unit.</li> <li>5. Replace the related harness.</li> </ol>
	<ul style="list-style-type: none"> <li>● Passenger air bag deactivation switch indicator circuit is shorted to some power supply circuit.</li> </ul>	
	<ul style="list-style-type: none"> <li>● Passenger air bag deactivation switch indicator circuit is shorted to ground.</li> </ul>	
INDEFINITE FAILURES [AIR BAGS]	<ul style="list-style-type: none"> <li>● Passenger air bag deactivation switch status is not identified.</li> </ul>	<ol style="list-style-type: none"> <li>1. Visually check wiring harness connections.</li> <li>2. Replace harness if it has visible damage.</li> <li>3. Replace passenger air bag deactivation switch.</li> <li>4. Replace air bag diagnosis sensor unit.</li> <li>5. Replace the related harness.</li> </ol>

\*: Follow the procedures in numerical order when repairing malfunctioning parts. Confirm whether malfunction is eliminated using the “AIR BAG” warning lamp (in User mode) or CONSULT-II each time repair is finished. If malfunction is still observed, proceed to the next step. When malfunction is eliminated, further repair work is not required.

# SUPPLEMENTAL RESTRAINT SYSTEM (SRS)

 Trouble Diagnoses with CONSULT-II (Cont'd)

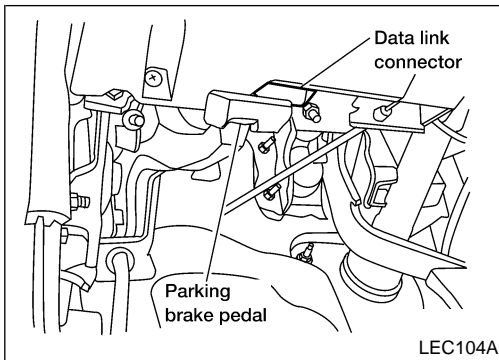

## DIAGNOSTIC PROCEDURE 3

=NERS0023S02

### Final checking after repairing SRS by using CONSULT-II — Diagnosis mode

1. After repairing SRS, connect both battery cables.
2. Connect CONSULT-II to data link connector.
3. Turn ignition switch ON.

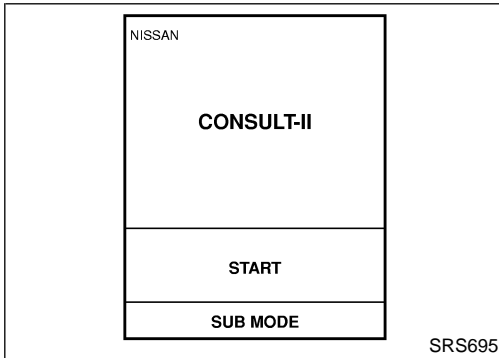

4. Touch "START".

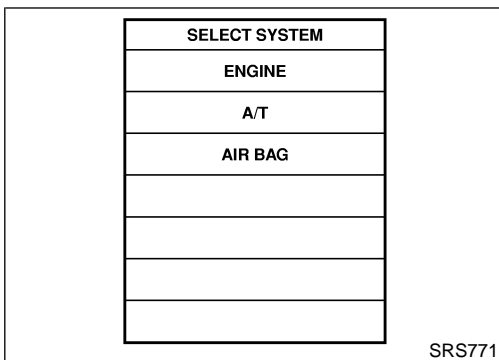

5. Touch "AIR BAG".

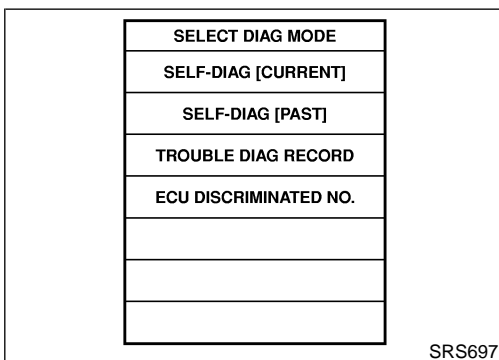

6. Touch "SELF-DIAG [CURRENT]".

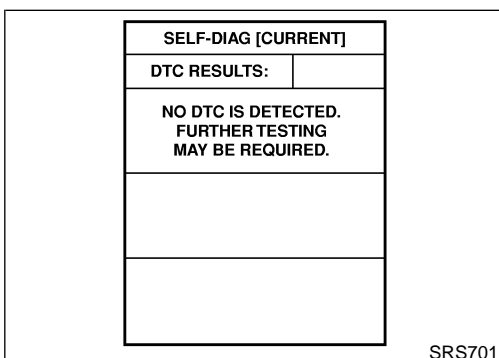

7. If no malfunction is detected on "SELF-DIAG [CURRENT]", repair of SRS is completed. Refer to step 8. If any malfunction was detected on "SELF-DIAG [CURRENT]", the malfunctioning part is not repaired completely or another malfunctioning part is detected. Refer to "DIAGNOSTIC PROCEDURE 2", RS-42 and repair malfunctioning part completely.

GI

MA

EM

LC

EC

FE

CL

MT

AT

TF

PD

AX

SU

BR

ST

RS

BT

HA

SC

EL

IDX

# SUPPLEMENTAL RESTRAINT SYSTEM (SRS)

Trouble Diagnoses with CONSULT-II (Cont'd)

SELF-DIAG [CURRENT]
DTC RESULTS:
PRE-TEN FRONT LH [OPEN]
ERASE

WRS259

8. Touch "ERASE".

**NOTE:**

Touch "ERASE" to clear the memory of the malfunction ("SELF-DIAG [PAST]").

If the memory of the malfunction in "SELF-DIAG [PAST]" is not erased, the User mode BAG shows the system malfunction by the operation of the "AIR BAG" warning lamp even if the malfunction is repaired completely.

SELECT DIAG MODE
SELF-DIAG [CURRENT]
SELF-DIAG [PAST]
TROUBLE DIAG RECORD
ECU DISCRIMINATED NO.

SRS697

9. Touch "BACK" key of CONSULT-II to "SELECT DIAG MODE" screen. Touch "SELF-DIAG [PAST]".

SELF-DIAG [PAST]
DTC RESULTS:
NO DTC IS DETECTED. FURTHER TESTING MAY BE REQUIRED.

SRS702

10. Check that no malfunction is detected on "SELF-DIAG [PAST]".

11. Touch "BACK" key of CONSULT-II until "SELECT SYSTEM" appears in order to return to User mode from Diagnosis mode.

12. Turn ignition switch OFF, then turn off and disconnect CONSULT-II.

13. Go to "SRS Operation Check", RS-42 to check SRS operation by using "AIR BAG" warning lamp with User mode.

**DIAGNOSTIC PROCEDURE 4 (CONTINUED FROM DIAGNOSTIC PROCEDURE 2)**

NERS0023S03

**Inspecting SRS malfunction record**

<b>1</b>	<b>CHECK FOR PROBLEM CODE THAT MIGHT NOT HAVE BEEN ERASED AFTER PREVIOUS REPAIR</b>	
Is it the first time for maintenance of SRS?		
Yes or No		
Yes	▶	Go to "DIAGNOSTIC PROCEDURE 5", RS-49.
No	▶	Self-diagnosis result "SELF-DIAG [PAST]" (previously stored in the memory) might not have been erased after repair. Go to "DIAGNOSTIC PROCEDURE 3", step 8, RS-47.



# SUPPLEMENTAL RESTRAINT SYSTEM (SRS)

Trouble Diagnoses with CONSULT-II (Cont'd)

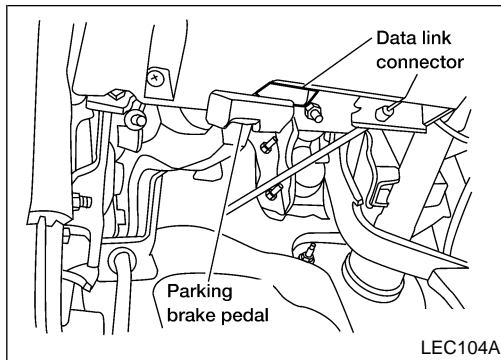

## DIAGNOSTIC PROCEDURE 5

NEFS0023S04

### Inspecting SRS intermittent malfunction by using CONSULT-II — Diagnosis mode

1. Turn ignition switch OFF.
2. Connect CONSULT-II to data link connector.
3. Turn ignition switch ON.

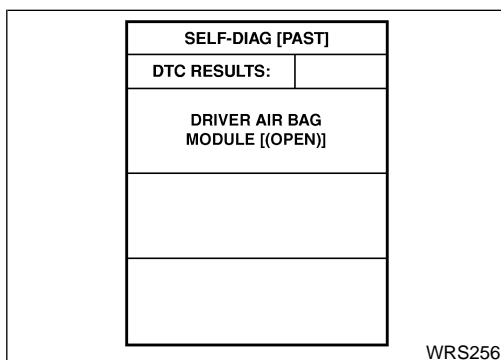
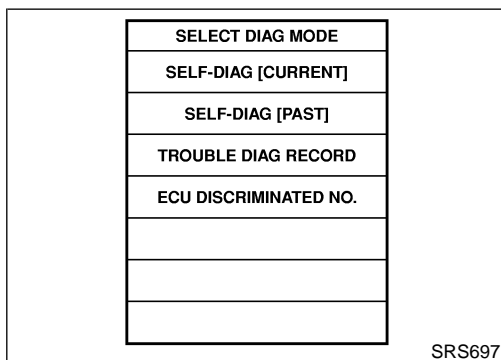
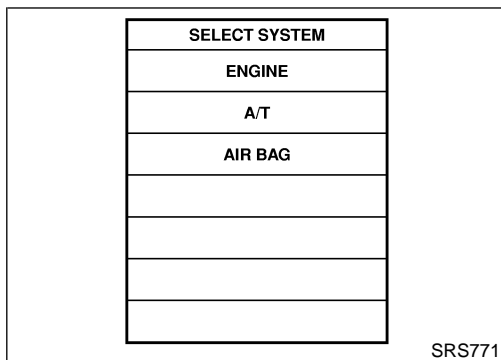
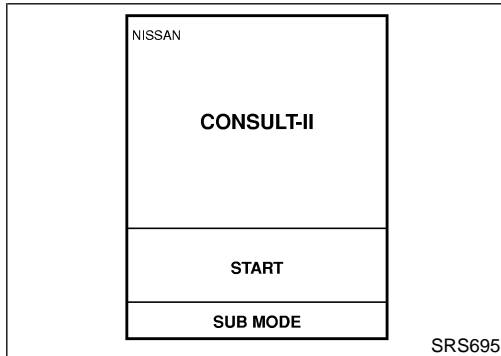

4. Touch "START".

5. Touch "AIR BAG".

6. Touch "SELF-DIAG [PAST]".

7. If self-diagnosis result is displayed on "SELF-DIAG [PAST]", go to step 10.

GI

MA

EM

LC

EC

FE

CL

MT

AT

TF

PD

AX

SU

BR

ST

**RS**

BT

HA

SC

EL

IDX

## SUPPLEMENTAL RESTRAINT SYSTEM (SRS)

 Trouble Diagnoses with CONSULT-II (Cont'd)

SELF-DIAG [PAST]	
DTC RESULTS:	
NO DTC IS DETECTED. FURTHER TESTING MAY BE REQUIRED.	

SRS702

If no malfunction is detected on "SELF-DIAG [PAST]", touch "BACK" and go back to "SELECT DIAG MODE".

SELECT DIAG MODE
SELF-DIAG [CURRENT]
SELF-DIAG [PAST]
TROUBLE DIAG RECORD
ECU DISCRIMINATED NO.

SRS697

8. Touch "TROUBLE DIAG RECORD".

**NOTE:**

With "TROUBLE DIAG RECORD", self-diagnosis results previously erased by a reset operation can be displayed.

TROUBLE DIAG RECORD	
DTC RESULTS:	
DRIVER AIR BAG MODULE [(OPEN)]	

WRS257

9. Self-diagnosis result is displayed on "TROUBLE DIAG RECORD".

10. Touch "PRINT".

11. Compare self-diagnosis result to "Intermittent Malfunction Diagnostic Code Chart", RS-51.

12. Touch "BACK" key of CONSULT-II until "SELECT SYSTEM" appears.

13. Turn ignition switch OFF, then turn off and disconnect CONSULT-II, and both battery cables.

14. Repair the system as outlined by the repair order that corresponds to the self-diagnosis result in "Intermittent Malfunction Diagnostic Code Chart", RS-51. For replacement procedure of component parts, refer to RS-17.

15. Go to "DIAGNOSTIC PROCEDURE 3", RS-47 for final checking.

# SUPPLEMENTAL RESTRAINT SYSTEM (SRS)

Trouble Diagnoses with CONSULT-II (Cont'd)

## Intermittent Malfunction Diagnostic Code Chart (SELF-DIAG [PAST] or TROUBLE DIAG RECORD)

=NERS0023S0401

Self-diagnosis result	Explanation	Repair order*		
NO DTC IS DETECTED.	When malfunction is indicated by the "AIR BAG" warning lamp in User mode	<ul style="list-style-type: none"> <li>Low battery voltage (Less than 9V)</li> </ul>	<ul style="list-style-type: none"> <li>Go to "DIAGNOSTIC PROCEDURE 3", RS-47 after charging battery.</li> </ul>	GI
	<ul style="list-style-type: none"> <li>No malfunction is detected.</li> </ul>		<ul style="list-style-type: none"> <li>Go to "DIAGNOSTIC PROCEDURE 3", RS-47.</li> </ul>	MA
DRIVER AIRBAG MODULE [OPEN]	<ul style="list-style-type: none"> <li>Driver air bag module circuit is open. (including the spiral cable)</li> </ul>	<ol style="list-style-type: none"> <li>Visually check the wiring harness connection.</li> <li>Replace the harness if it has visible damage.</li> <li>If the harness check result is OK, replace driver air bag module (Before disposal of it, it must be deployed.), diagnosis sensor unit and spiral cable.</li> </ol>	<ol style="list-style-type: none"> <li>1. Visually check the wiring harness connection.</li> <li>2. Replace the harness if it has visible damage.</li> <li>3. If the harness check result is OK, replace driver air bag module (Before disposal of it, it must be deployed.), diagnosis sensor unit and spiral cable.</li> </ol>	EM
DRIVER AIRBAG MODULE [VB-SHORT]	<ul style="list-style-type: none"> <li>Driver air bag module circuit is shorted to some power supply circuit. (including the spiral cable)</li> </ul>		LC	
DRIVER AIRBAG MODULE [GND-SHORT]	<ul style="list-style-type: none"> <li>Driver air bag module circuit is shorted to ground. (including the spiral cable)</li> </ul>		EC	
DRIVER AIRBAG MODULE [SHORT]	<ul style="list-style-type: none"> <li>Driver air bag module circuits are shorted to each other.</li> </ul>		FE	
ASSIST A/B MODULE [VB-SHORT]	<ul style="list-style-type: none"> <li>Front passenger air bag module circuit is shorted to some power supply circuit.</li> </ul>	<ol style="list-style-type: none"> <li>1. Visually check the wiring harness connection.</li> <li>2. Replace the harness if it has visible damage.</li> <li>3. If the harness check result is OK, replace front passenger air bag module (Before disposal of it, it must be deployed.), and diagnosis sensor unit.</li> </ol>	<ol style="list-style-type: none"> <li>1. Visually check the wiring harness connection.</li> <li>2. Replace the harness if it has visible damage.</li> <li>3. If the harness check result is OK, replace front passenger air bag module (Before disposal of it, it must be deployed.), and diagnosis sensor unit.</li> </ol>	CL
ASSIST A/B MODULE [OPEN]	<ul style="list-style-type: none"> <li>Front passenger air bag module circuit is open.</li> </ul>		MT	
ASSIST A/B MODULE [GND-SHORT]	<ul style="list-style-type: none"> <li>Front passenger air bag module circuit is shorted to ground.</li> </ul>		AT	
ASSIST A/B MODULE [SHORT]	<ul style="list-style-type: none"> <li>Front passenger air bag module circuits are shorted to each other.</li> </ul>		TF	
PRE-TEN FRONT LH [OPEN]	<ul style="list-style-type: none"> <li>The circuit for driver seat belt pre-tensioner is open.</li> </ul>	<ol style="list-style-type: none"> <li>1. Visually check the wiring harness connections.</li> <li>2. Replace the harness if it has visible damage.</li> <li>3. If the harness check is OK, replace the diagnosis sensor unit and driver seat belt. (Before disposing the driver seat belt pre-tensioner, it must be deployed.)</li> </ol>	<ol style="list-style-type: none"> <li>1. Visually check the wiring harness connections.</li> <li>2. Replace the harness if it has visible damage.</li> <li>3. If the harness check is OK, replace the diagnosis sensor unit and driver seat belt. (Before disposing the driver seat belt pre-tensioner, it must be deployed.)</li> </ol>	PD
PRE-TEN FRONT LH [VB-SHORT]	The circuit for driver seat belt pre-tensioner is shorted to some power supply circuit.		AX	
PRE-TEN FRONT LH [GND-SHORT]	<ul style="list-style-type: none"> <li>The circuit for driver seat belt pre-tensioner is shorted to ground.</li> </ul>		SU	
PRE-TEN FRONT RH [OPEN]	<ul style="list-style-type: none"> <li>The circuit for passenger seat belt pre-tensioner is open.</li> </ul>	<ol style="list-style-type: none"> <li>1. Visually check the wiring harness connections.</li> <li>2. Replace the harness if it has visible damage.</li> <li>3. If the harness check is OK, replace the diagnosis sensor unit and front passenger seat belt. (Before disposing the passenger seat belt pre-tensioner, it must be deployed.)</li> </ol>	<ol style="list-style-type: none"> <li>1. Visually check the wiring harness connections.</li> <li>2. Replace the harness if it has visible damage.</li> <li>3. If the harness check is OK, replace the diagnosis sensor unit and front passenger seat belt. (Before disposing the passenger seat belt pre-tensioner, it must be deployed.)</li> </ol>	BR
PRE-TEN FRONT RH [VB-SHORT]	The circuit for passenger seat belt pre-tensioner is shorted to some power supply circuit.		ST	
PRE-TEN FRONT RH [GND-SHORT]	<ul style="list-style-type: none"> <li>The circuit for passenger seat belt pre-tensioner is shorted to ground.</li> </ul>		RS	
CONTROL UNIT	<ul style="list-style-type: none"> <li>Diagnosis sensor unit is malfunctioning.</li> </ul>	<ol style="list-style-type: none"> <li>1. Visually check the wiring harness connection.</li> <li>2. Replace the harness if it has visible damage.</li> <li>3. If the harness check is OK, replace the diagnosis sensor unit.</li> </ol>	<ol style="list-style-type: none"> <li>1. Visually check the wiring harness connection.</li> <li>2. Replace the harness if it has visible damage.</li> <li>3. If the harness check is OK, replace the diagnosis sensor unit.</li> </ol>	BT

## SUPPLEMENTAL RESTRAINT SYSTEM (SRS)

 Trouble Diagnoses with CONSULT-II (Cont'd)

Self-diagnosis result	Explanation	Repair order*
Code B4 or PASS A/B DEACT SW	● Activate terminal is open.	<ol style="list-style-type: none"> <li>1. Visually check wiring harness connections.</li> <li>2. Replace harness if it has visible damage.</li> <li>3. If the harness visual check result is OK, replace passenger air bag deactivation switch. (The key cylinder of passenger air bag deactivation switch does not have to be replaced.)</li> </ol>
	● Activate terminal is shorted to ground.	
	● Deactivate terminal is open.	
	● Deactivate terminal is shorted to ground.	
	● Activate terminal and deactivate terminal are shorted to each other.	
Code B5 or PASS A/B DEACT SW INDICATOR	● Passenger air bag deactivation switch indicator circuit is open.	<ol style="list-style-type: none"> <li>1. Visually check wiring harness connections.</li> <li>2. Replace harness if it has visible damage.</li> <li>3. If the harness visual check result is OK, replace passenger air bag deactivation switch indicator.</li> </ol>
	● Passenger air bag deactivation switch indicator circuit is shorted to some power supply circuit.	
	● Passenger air bag deactivation switch indicator circuit is shorted to ground.	
INDEFINITE FAILURES [AIR BAGS]	● Passenger air bag deactivation switch status is not identified.	<ol style="list-style-type: none"> <li>1. Visually check wiring harness connections.</li> <li>2. Replace harness if it has visible damage.</li> <li>3. If the harness visual check result is OK, replace passenger air bag deactivation switch and air bag diagnosis sensor unit.</li> </ol>

\*: Intermittent malfunction areas cannot be easily located. For this reason, perform the procedures outlined under the repair order, then make the final system check.

# SUPPLEMENTAL RESTRAINT SYSTEM (SRS)

Trouble Diagnoses without CONSULT-II

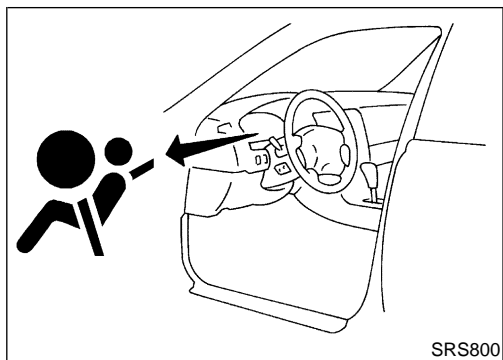

## Trouble Diagnoses without CONSULT-II

=NERS0024

### DIAGNOSTIC PROCEDURE 6

NERS0024S01

Inspecting SRS malfunctioning parts by using "AIR BAG" warning lamp — Diagnosis mode

#### NOTE:

SRS will not enter Diagnosis mode if no malfunction is detected in User mode.

1. Turn ignition switch "ON".
2. After "AIR BAG" warning lamp lights for 7 seconds, turn ignition switch "OFF" within 1 second.
3. Wait more than 3 seconds.
4. Repeat steps 1 to 3 three times.
5. Turn ignition switch "ON".  
SRS is now in Diagnosis mode.
6. "AIR BAG" warning lamp operates in Diagnosis mode as follows:

#### NOTE:

If SRS does not enter Diagnosis mode even though malfunction is detected in User mode, check the battery voltage.

If the battery voltage is less than 9V, charge the battery. Then refer to "DIAGNOSTIC PROCEDURE 7", RS-57.

If the battery voltage is OK, replace the diagnosis sensor unit.

No.	"AIR BAG" warning lamp flash pattern — Diagnosis mode —	SRS condition
1		<p>a through b are repeated.</p> <ul style="list-style-type: none"> <li>• Diagnosis results (previously stored in the memory) might not be erased after repair.</li> <li>• Intermittent malfunction has been detected in the past.</li> </ul> <p>Go to "DIAGNOSTIC PROCEDURE 8", RS-58.</p>
2		<p>a through d are repeated.</p> <p><b>b</b> — Driver and passenger air bag and seat belt pre-tensioner marker (For identifying driver air bag, passenger air bag and/or seat belt pre-tensioners malfunctioning)</p> <p><b>d</b> — Indicates malfunctioning part. The number of flash varies with malfunctioning part (0.5 sec. ON and 0.5 sec. OFF is counted as one flash.)</p> <p>The system is malfunctioning and needs to be repaired.</p>

7. Malfunctioning part is indicated by the number of flashes (part **d**). Compare the number of flashes to "Air Bag Warning Lamp Flash Code Chart". Refer to "Air Bag Warning Lamp Flash Code Chart (Diagnosis Mode)", RS-55, and locate malfunctioning part.
8. Turn ignition switch "OFF", and disconnect both battery cables.

## SUPPLEMENTAL RESTRAINT SYSTEM (SRS)

 *Trouble Diagnoses without CONSULT-II (Cont'd)*

---

9. Repair the system as outlined by the "Repair order" in "Warning Lamp Flash Code Chart" that corresponds to the flash code. For replacement procedure of component parts, refer to the applicable Removal and Installation procedure.
10. After repairing the system, refer to "DIAGNOSTIC PROCEDURE 7", RS-57.

# SUPPLEMENTAL RESTRAINT SYSTEM (SRS)

Trouble Diagnoses without CONSULT-II (Cont'd)

## Air Bag Warning Lamp Flash Code Chart (Diagnosis Mode)

=NERS0024S0101

Warning lamp	Flash code d (# of flashes)	Explanation	Repair order <b>*Recheck SRS at each replacement.</b>
"AIR BAG" warning lamp	0	<ul style="list-style-type: none"> <li>Self-diagnosis result (previously stored in the memory) might not have been erased after repair.</li> <li>Intermittent malfunction has been detected in the past.</li> </ul>	Go to "DIAGNOSTIC PROCEDURE 8", RS-58.
	1	The driver seat belt pre-tensioner circuit is malfunctioning.	<ol style="list-style-type: none"> <li>Visually check wiring harness connections.</li> <li>Replace harness if it has visible damage.</li> <li>Replace driver seat belt pre-tensioner. (Before disposing, it must be deactivated.)</li> <li>Replace air bag diagnosis sensor unit.</li> <li>Replace the related harness.</li> </ol>
	2	The driver air bag module circuit is malfunctioning.	<ol style="list-style-type: none"> <li>Visually check wiring harness connections.</li> <li>Replace harness if it has visible damage.</li> <li>Replace spiral cable.</li> <li>Replace driver air bag module. (Before disposing of it, it must be deployed.)</li> <li>Replace air bag diagnosis sensor unit.</li> <li>Replace the related harness.</li> </ol>
	3	The passenger seat belt pre-tensioner circuit is malfunctioning.	<ol style="list-style-type: none"> <li>Visually check wiring harness connections.</li> <li>Replace harness if it has visible damage.</li> <li>Replace passenger seat belt pre-tensioner. (Before disposing of it, it must be deactivated.)</li> <li>Replace air bag diagnosis sensor unit.</li> <li>Replace the related harness.</li> </ol>
	7	The air bag diagnosis sensor unit is malfunctioning.	<ol style="list-style-type: none"> <li>Visually check wiring harness connections.</li> <li>Replace harness if it has visible damage.</li> <li>Replace air bag diagnosis sensor unit.</li> <li>Replace the related harness.</li> </ol>
	8	The passenger air bag module circuit is malfunctioning.	<ol style="list-style-type: none"> <li>Visually check wiring harness connections.</li> <li>Replace harness if it has visible damage.</li> <li>Replace passenger air bag module. (Before disposing of it, it must be deployed.)</li> <li>Replace air bag diagnosis sensor unit.</li> <li>Replace the related harness.</li> </ol>
	9	Passenger air bag deactivation switch is not identified.	<ol style="list-style-type: none"> <li>Visually check wiring harness connections.</li> <li>Replace harness if it has visible damage.</li> <li>Replace passenger air bag deactivation switch. (The key cylinder of the deactivation switch does not have to be replaced.)</li> <li>Replace air bag diagnosis sensor unit.</li> <li>Replace the related harness.</li> </ol>

GI

MA

EM

LC

EC

FE

CL

MT

AT

TF

PD

AX

SU

BR

ST

**RS**

BT

HA

SC

EL

IDX

## SUPPLEMENTAL RESTRAINT SYSTEM (SRS)

⊗ Trouble Diagnoses without CONSULT-II (Cont'd)

Warning lamp	Flash code <b>d</b> (# of flashes)	Explanation	Repair order <b>*Recheck SRS at each replacement.</b>
“AIR BAG” warning lamp	10	Passenger air bag deactivation switch is malfunctioning.	<ol style="list-style-type: none"> <li>1. Visually check wiring harness connections.</li> <li>2. Replace harness if it has visible damage.</li> <li>3. Replace passenger air bag deactivation switch. (The key cylinder of the deactivation switch does not have to be replaced.)</li> <li>4. Replace air bag diagnosis sensor unit.</li> <li>5. Replace the related harness.</li> </ol>
	11	Passenger air bag deactivation switch indicator is malfunctioning.	<ol style="list-style-type: none"> <li>1. Visually check wiring harness connections.</li> <li>2. Replace harness if it has visible damage.</li> <li>3. Replace passenger air bag deactivation switch indicator.</li> <li>4. Replace air bag diagnosis sensor unit.</li> <li>5. Replace the related harness.</li> </ol>

\* Follow the procedures in numerical order when repairing malfunctioning parts. Confirm whether malfunction is eliminated using the “AIR BAG” warning lamp (in User mode) or CONSULT-II each time repair is finished. If malfunction is still observed, proceed to the next step. When malfunction is eliminated, further repair work is not required.



# SUPPLEMENTAL RESTRAINT SYSTEM (SRS)

Trouble Diagnoses without CONSULT-II (Cont'd)

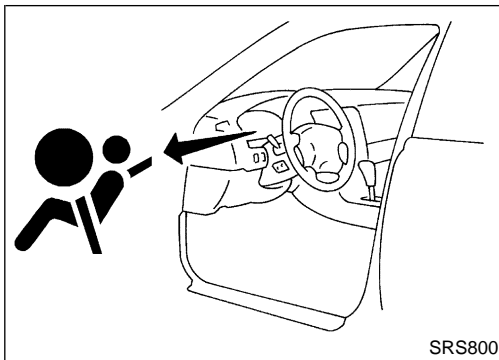

## DIAGNOSTIC PROCEDURE 7

Final checking after repairing SRS by using "AIR BAG" warning lamp — Diagnosis mode and User mode =NERS0024S02

1. After repairing SRS connect both battery cables.
2. Open driver's door.
3. Turn ignition switch from "OFF" to "ON".
4. "AIR BAG" warning lamp operates in Diagnosis mode as follows:

No.	"AIR BAG" warning lamp flash pattern — Diagnosis mode —	SRS condition
1	<p style="text-align: right;">SRS333</p>	<p>a through b are repeated.</p> <p>No malfunction is detected or repair is completed. No further action is necessary.</p>
2	<p style="text-align: right;">SRS341</p>	<p>a through d are repeated.</p> <p>b — Driver and passenger air bag and seat belt pre-tensioner marker (For identifying driver air bag, passenger air bag and/or seat belt pre-tensioners malfunctioning)</p> <p>d — Indicates malfunctioning part. The number of flashes varies with malfunctioning part (0.5 sec. ON and 0.5 sec. OFF is counted as one flash.)</p> <p>The system is malfunctioning and needs to be repaired.</p>

### NOTE:

When diagnosis sensor unit is replaced with new one, "AIR BAG" warning lamp will operate in User mode. Checking "AIR BAG" warning lamp operation in Diagnosis mode is not required. Go to step 6.

5. If "AIR BAG" warning lamp operates as shown in No. 1 in chart above, turn ignition switch "OFF" to reset from Diagnosis mode to User mode and to erase the memory of the malfunction. Then go to step 6.

If "AIR BAG" warning lamp operates as shown in No. 2 or No. 3 in chart above, the malfunctioning part is not repaired completely, or another malfunctioning part is detected. Refer to "DIAGNOSTIC PROCEDURE 6", RS-53, and repair malfunctioning part completely.

6. Turn ignition switch "ON". "AIR BAG" warning lamp operates in User mode. Compare "AIR BAG" warning lamp operation to the chart below.

### NOTE:

If switching Diagnosis mode to User mode is required while malfunction is being detected, by turning ignition switch as follows:

- 1) Turn ignition switch "ON".
- 2) After "AIR BAG" warning lamp lights for 7 seconds, turn ignition switch "OFF" within 1 second.
- 3) Wait more than 3 seconds.
- 4) Repeat steps 1 to 3 three times.

# SUPPLEMENTAL RESTRAINT SYSTEM (SRS)

⊗ Trouble Diagnoses without CONSULT-II (Cont'd)

5) Turn ignition switch "ON".  
SRS is now in User mode.

"AIR BAG" warning lamp operation — User mode —	SRS condition	Reference item
<p>MRS095A</p>	No malfunction is detected. No further action is necessary.	—
<p>MRS096A</p>	The system is malfunctioning and needs to be repaired as indicated.	Go to "DIAGNOSTIC PROCEDURE 6", RS-53.
<p>MRS097A</p>	Air bag is deployed. Seat belt pre-tensioner is deployed.	Go to "COLLISION DIAGNOSIS", RS-61.
<p>MRS098A</p>	Air bag fuse, diagnosis sensor unit or harness is malfunctioning and needs to be repaired.	Go to "DIAGNOSTIC PROCEDURE 9", RS-59.
<p>MRS098A</p>	One of the following has occurred and needs to be repaired. <ul style="list-style-type: none"> <li>• Meter fuse is blown.</li> <li>• "AIR BAG" warning lamp circuit has open or short.</li> <li>• Diagnosis sensor unit is malfunctioning.</li> </ul>	Go to "DIAGNOSTIC PROCEDURE 10", RS-61.

## DIAGNOSTIC PROCEDURE 8 (CONTINUED FROM DIAGNOSTIC PROCEDURE 6)

### Inspecting SRS malfunction record

NERS0024S03

<b>1</b>	<b>CHECK FOR PROBLEM CODE THAT MIGHT NOT HAVE BEEN ERASED AFTER PREVIOUS REPAIR</b>	
Is it the first time for maintenance of SRS?		
<b>Yes or No</b>		
Yes	▶	Go to "DIAGNOSTIC PROCEDURE 5", RS-49. (Further inspection cannot be performed without CONSULT-II.)
No	▶	Self-diagnosis result (previously stored in the memory) might not have been erased after repair. Go to "DIAGNOSTIC PROCEDURE 7", step 5, RS-57.

# SUPPLEMENTAL RESTRAINT SYSTEM (SRS)

Trouble Diagnoses: "AIR BAG" Warning Lamp Does Not Turn Off

## Trouble Diagnoses: "AIR BAG" Warning Lamp Does Not Turn Off DIAGNOSTIC PROCEDURE 9

=NERS0025

NERS0025S01

<b>1</b>	<b>CHECK FOR DEPLOYMENT OF AIR BAG MODULE</b>	
Is air bag module deployed?		
<b>Yes or No</b>		
Yes	▶	Refer to "Collision Diagnosis", RS-61.
No	▶	GO TO 2.

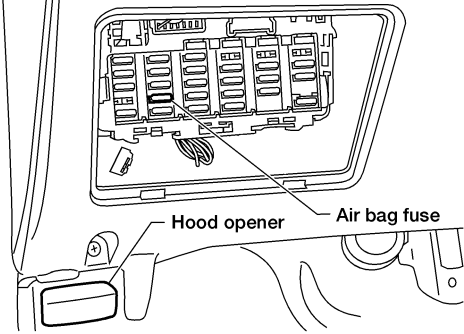
<b>2</b>	<b>CHECK AIR BAG FUSE</b>	
Is air bag fuse OK?		
 <p style="text-align: center;">Hood opener      Air bag fuse</p>		
ARS349		
<b>OK or NG</b>		
OK	▶	GO TO 4.
NG	▶	GO TO 3.

<b>3</b>	<b>CHECK AIR BAG FUSE AGAIN</b>	
Replace air bag fuse and turn ignition switch ON.		
<b>Does air bag fuse blow again?</b>		
Yes	▶	Repair main harness.
No	▶	<b>INSPECTION END</b>

GI  
MA  
EM  
LC  
EC  
FE  
CL  
MT  
AT  
TF  
PD  
AX  
SU  
BR  
ST  
RS  
BT  
HA  
SC  
EL  
IDX

# SUPPLEMENTAL RESTRAINT SYSTEM (SRS)

*Trouble Diagnoses: "AIR BAG" Warning Lamp Does Not Turn Off (Cont'd)*

<b>4</b>	<b>CHECK AIR BAG DIAGNOSIS SENSOR UNIT</b>									
<p>Ⓜ</p> <ol style="list-style-type: none"> <li>1. Turn ignition switch OFF.</li> <li>2. Connect CONSULT-II.</li> <li>3. Turn ignition switch ON.</li> <li>4. Touch "START" on CONSULT-II screen.</li> </ol> <p><b>Is "AIRBAG" displayed on CONSULT-II?</b></p> <div style="text-align: center; margin: 20px 0;"> <table border="1" style="margin: auto; border-collapse: collapse;"> <tr><td style="text-align: center;">SELECT DIAG MODE</td></tr> <tr><td style="text-align: center;">SELF-DIAG [CURRENT]</td></tr> <tr><td style="text-align: center;">SELF-DIAG [PAST]</td></tr> <tr><td style="text-align: center;">TROUBLE DIAG RECORD</td></tr> <tr><td style="text-align: center;">ECU DISCRIMINATED NO.</td></tr> <tr><td style="text-align: center;"> </td></tr> <tr><td style="text-align: center;"> </td></tr> <tr><td style="text-align: center;"> </td></tr> </table> </div> <p style="text-align: right; margin-right: 20px;">SRS697</p> <p style="text-align: center;"><b>Yes or No</b></p>			SELECT DIAG MODE	SELF-DIAG [CURRENT]	SELF-DIAG [PAST]	TROUBLE DIAG RECORD	ECU DISCRIMINATED NO.			
SELECT DIAG MODE										
SELF-DIAG [CURRENT]										
SELF-DIAG [PAST]										
TROUBLE DIAG RECORD										
ECU DISCRIMINATED NO.										
Yes	▶	GO TO 5.								
No	▶	Visually check wiring harness connection of air bag diagnosis sensor unit. If harness connection check result is OK, replace air bag diagnosis sensor unit.								

<b>5</b>	<b>CHECK HARNESS CONNECTION</b>	
<p>Are harness connections between "AIR BAG" warning lamp and air bag diagnosis sensor unit OK?</p> <p style="text-align: center;"><b>OK or NG</b></p>		
OK	▶	Replace air bag diagnosis sensor unit.
NG	▶	Connect combination meter, air bag diagnosis sensor unit and inline harness connectors properly. If "AIR BAG" warning lamp still does not go off, repair main harness.

# SUPPLEMENTAL RESTRAINT SYSTEM (SRS)

Trouble Diagnoses: "AIR BAG" Warning Lamp Does Not Turn On

## Trouble Diagnoses: "AIR BAG" Warning Lamp Does Not Turn On DIAGNOSTIC PROCEDURE 10

=NERS0026

NERS0026S01

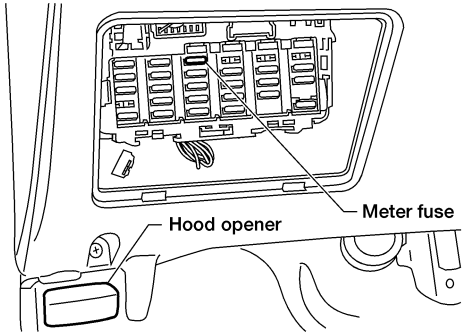
<b>1</b>	<b>CHECK "AIR BAG" WARNING LAMP FUSE</b>	
Is meter fuse OK?		
 <p style="text-align: center;">OK or NG</p>		
OK	▶	GO TO 3.
NG	▶	GO TO 2.

<b>2</b>	<b>CHECK "AIR BAG" WARNING LAMP FUSE AGAIN</b>	
Replace meter fuse and turn ignition switch ON.		
<b>Does meter fuse blow again?</b>		
Yes	▶	Repair main harness.
No	▶	<b>INSPECTION END</b>

<b>3</b>	<b>CHECK HARNESS CONNECTION BETWEEN AIR BAG DIAGNOSIS SENSOR UNIT AND "AIR BAG" WARNING LAMP</b>	
Disconnect air bag diagnosis sensor unit harness connector and turn ignition switch ON.		
<b>Does "AIR BAG" warning lamp turn on?</b>		
Yes	▶	Replace air bag diagnosis sensor unit.
No	▶	Check the ground circuit of "AIR BAG" warning lamp. If ground circuit is OK, replace combination meter.

## Collision Diagnosis

NERS0028

To repair the SRS, perform the following steps.

**When SRS is activated in a collision:**

- 1) Replace the diagnosis sensor unit.
- 2) Remove the air bag modules and seat belt pre-tensioner assemblies.
- 3) Check the SRS components using the table shown below:
  - Replace any SRS components showing visible signs of damage (dents, cracks and deformation).
- 4) Install new air bag modules and seat belt pre-tensioner assemblies.
- 5) Conduct self-diagnosis using CONSULT-II or "AIR BAG" warning lamp. Refer to "SRS Operation Check", RS-42. Ensure entire SRS operates properly.

# SUPPLEMENTAL RESTRAINT SYSTEM (SRS)

Collision Diagnosis (Cont'd)

## When SRS is not activated in a collision:

- 1) Check the SRS components using the table shown below:
  - Replace any SRS components showing visible signs of damage (dents, cracks and deformation).
- 2) Conduct self-diagnosis using CONSULT-II or "AIR BAG" warning lamp. Refer to "SRS Operation Check", RS-42. Ensure entire SRS operates properly.

## SRS INSPECTION

NERS0028S01

Part	SRS is activated	SRS is NOT activated
Air bag module (driver and passenger side)	REPLACE Install with new bolts coated with bonding agent.	<ol style="list-style-type: none"> <li>1. Remove air bag module. Check harness cover and connectors for damage, terminals for deformities, and harness for binding.</li> <li>2.                             <ol style="list-style-type: none"> <li>a. Install driver air bag module into the steering wheel to check fit and alignment with the wheel.</li> <li>b. Install passenger air bag module into the instrument panel to check fit with the instrument panel.</li> </ol> </li> <li>3. No damage found, reinstall with new bolts coated with bonding agent.</li> <li>4. If damaged—REPLACE. Install air bag modules with new bolts coated with bonding agent. Air bag must be deployed before discarding.</li> </ol>
Seat belt pre-tensioner assembly	REPLACE Install seat belt pre-tensioner with new bolts.	<ol style="list-style-type: none"> <li>1. Remove seat belt pre-tensioners. Check harness cover and connectors for damage, terminals for deformities, and harness for binding.</li> <li>2. Check belts for damage and anchors for loose mounting.</li> <li>3. Check retractor for smooth operation.</li> <li>4. If no damage is found, reinstall seat belt pre-tensioner assembly.</li> <li>5. If damaged—REPLACE. Install the seat belt pre-tensioners with new bolts coated with bonding agent. Seat belt pre-tensioners must be deployed before discarding.</li> </ol>
Diagnosis sensor unit	REPLACE Install with new bolts coated with bonding agent.	<ol style="list-style-type: none"> <li>1. Check case for dents, cracks or deformities.</li> <li>2. Check connectors for damage, and terminals for deformities.</li> <li>3. If no damage is found, reinstall with new bolts and ground bolt coated with bonding agent.</li> <li>4. If damaged—REPLACE. Install diagnosis sensor unit with new bolts and ground bolt coated with bonding agent.</li> </ol>
Steering wheel		<ol style="list-style-type: none"> <li>1. Visually check steering wheel for deformities.</li> <li>2. Install air bag module to check fit or alignment with steering wheel.</li> <li>3. Check steering wheel for excessive free play.</li> <li>4. If no damage is found, reinstall with new bolts.</li> <li>5. If damaged—REPLACE.</li> </ol>
Spiral cable		<ol style="list-style-type: none"> <li>1. Visually check spiral cable and combination switch for damage.</li> <li>2. Check connectors and protective tape for damage.</li> <li>3. Check steering wheel for noise, binding or heavy operation.</li> <li>4. If no damage is found, reinstall with new bolts.</li> <li>5. If damaged—REPLACE.</li> </ol>
Harness and Connectors		<ol style="list-style-type: none"> <li>1. Check connectors for poor connection, damage, and terminals for deformities.</li> <li>2. Check harness for binding, chafing, cuts, or deformities.</li> <li>3. If no damage is found, reinstall the harness and connectors.</li> <li>4. Damaged—REPLACE damaged harness. Do not attempt to repair, splice or modify any SRS harness.</li> </ol>
Passenger air bag deactivation switch and indicator		<ol style="list-style-type: none"> <li>1. Visually check passenger air bag deactivation switch and indicator for dents, cracks and deformities.</li> <li>2. Check the harness and connectors for damage, and terminals for deformities.</li> <li>3. If damaged—REPLACE.</li> </ol> <p><b>WARNING:</b> After SRS maintenance or repair, make sure the passenger air bag deactivation switch is in the same position (ON or OFF) as when the vehicle arrived for service.</p>

# SUPPLEMENTAL RESTRAINT SYSTEM (SRS)

Collision Diagnosis (Cont'd)

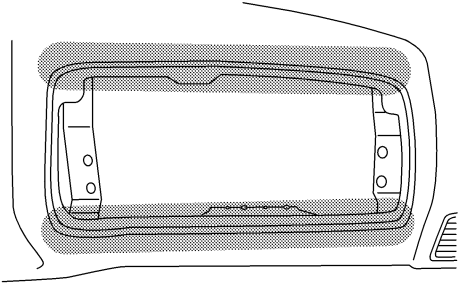
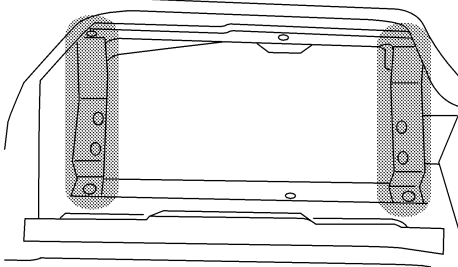
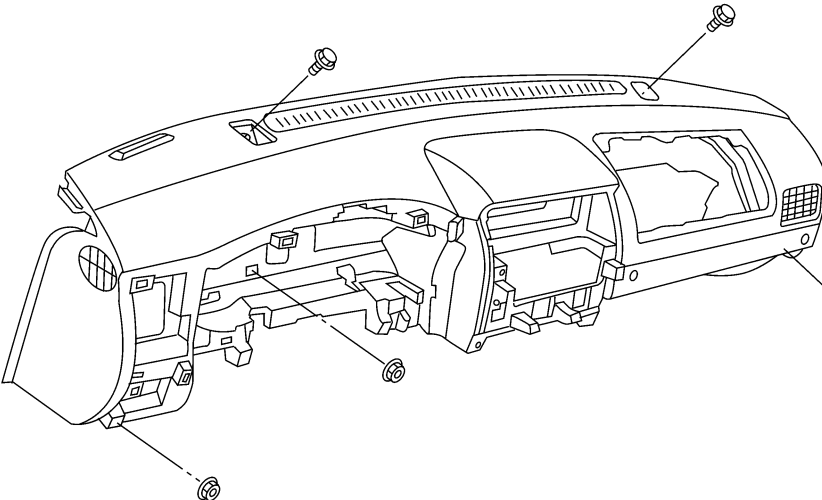
Part	SRS is activated	SRS is NOT activated
Instrument panel	<p>1. When passenger air bag inflates, check the following points for bending, deformities and cracks:</p> <ul style="list-style-type: none"> <li>Opening portion for passenger air bag</li> </ul>  <p>● Passenger air bag module brackets <b>Back face of instrument panel</b></p>  <ul style="list-style-type: none"> <li>The portions securing the instrument panel</li> </ul>  <p>2. If no damage is found, reinstall the instrument panel. 3. If damaged — REPLACE the instrument panel with new nuts and bolts.</p>	<p>GI MA EM LC EC FE CL MT AT TF PD AX SU BR ST <b>RS</b> BT HA SC EL IDX</p>

## NOTES