

SECTION **BRC**

BRAKE CONTROL SYSTEM

A
B
C
D
E

CONTENTS

ABS	
PRECAUTIONS	4
Precautions for Supplemental Restraint System (SRS) "AIR BAG" and "SEAT BELT PRE-TENSIONER"	4
Precautions for Brake System	4
Wiring Diagrams and Trouble Diagnosis	4
Precautions for Brake Control	4
PREPARATION	6
Special Service Tools	6
Commercial Service Tools	6
GENERAL INFORMATION	7
Fail-Safe	7
ABS SYSTEM	7
Hydraulic Circuit Diagram	7
ABS Function	7
System Diagram	8
TROUBLE DIAGNOSIS	9
How to Proceed With Diagnosis	9
BASIC CONCEPT	9
DIAGNOSIS FLOWCHART	10
ASKING COMPLAINTS	11
EXAMPLE OF DIAGNOSIS SHEET	11
Component Installation Location	12
Schematic	13
2-WHEEL DRIVE	13
4-WHEEL DRIVE	14
Wiring Diagram — ABS — 2WD —	15
Wiring Diagram — ABS — 4WD —	18
ABS Actuator and Electric Unit (Control Unit) Input/Output Signal Standard	21
STANDARDS USING CIRCUIT TESTER AND OSCILLOSCOPE	21
STANDARDS BY CONSULT-II	23
CONSULT-II Functions	24
CONSULT-II FUNCTION APPLICATION TABLE	24
CONSULT-II BASIC OPERATION PROCEDURE	25
SELF-DIAGNOSIS	26
DATA MONITOR	29
ACTIVE TEST	31
For Fast and Accurate Diagnosis	33
PRECAUTIONS FOR DIAGNOSIS	33
Basic Inspection	34
BASIC INSPECTION 1: BRAKE FLUID LEVEL AND LEAK INSPECTION	34
BASIC INSPECTION 2: INSPECTION FOR LOOSENESS OF POWER SYSTEM TERMINALS	34
BASIC INSPECTION 3: INSPECTION OF ABS WARNING LAMP	34
Symptom Chart	34
Inspection 1 Wheel Sensor System	35
INSPECTION PROCEDURE	35
Inspection 2 ABS Actuator and Electric Unit (Control Unit) System	36
Inspection 3 Pressure Switch and Circuit Between Pressure Switch and ABS Actuator and Electric Unit (Control Unit)	37
Inspection 4 Solenoid Valve and Circuits	38
Inspection 5 Actuator Motor, Motor Relay, and Circuit	39
Inspection 6 Stop Lamp Switch and Circuit	40
Inspection 7 ABS Actuator and Electric Unit (Control Unit) Power Supply and Ground Circuit	41
Inspection 8 ABS Warning Lamp Does Not Come On When Ignition Switch Is Turned On	42
Inspection 9 When "DECEL G-SENSOR" Appears on Self-Diagnosis Results Display (4WD Models)..	44
Symptom 1 ABS Works Frequently	44
Symptom 2 Unexpected Pedal Reaction	44
Symptom 3 Long Stopping Distance	45
Symptom 4 ABS Does Not Work	46
Symptom 5 Pedal Vibration and Noise	46
REMOVAL AND INSTALLATION	48
Front Wheel Sensor	48
Rear Wheel Sensor	48
4WD MODELS	48
2WD MODELS	48
Front Sensor Rotor	49

BRC

G
H
I
J
K
L
M

REMOVAL	49	SELF-DIAGNOSIS	79
INSTALLATION	49	DATA MONITOR	84
Rear Sensor Rotor (4WD)	49	ACTIVE TEST	87
REMOVAL	49	For Fast and Accurate Diagnosis	90
INSTALLATION	50	PRECAUTIONS FOR DIAGNOSIS	90
ABS Actuator and Electric Unit	51	Basic Inspection	92
REMOVAL	51	BASIC INSPECTION 1: BRAKE FLUID LEVEL AND LEAK INSPECTION	92
INSTALLATION	51	BASIC INSPECTION 2: INSPECTION FOR LOOSENESS OF POWER SYSTEM TERMI- NALS	92
VDC/TCS/ABS		BASIC INSPECTION 3: INSPECTION OF ABS WARNING LAMP, VDC OFF INDICATOR LAMP, AND SLIP INDICATOR LAMP	92
PRECAUTIONS	52	Symptom Chart	92
Precautions for Supplemental Restraint System (SRS) "AIR BAG" and "SEAT BELT PRE-TEN- SIONER"	52	Inspection 1 Wheel Sensor System	94
Precautions for Brake System	52	INSPECTION PROCEDURE	94
Wiring Diagrams and Trouble Diagnosis	52	Inspection 2 ABS Actuator and Electric Unit (Control Unit) System	95
Precautions for Brake Control	52	Inspection 3 Pressure Sensor and Circuit Between Pressure Sensor and ABS Actuator and Electric Unit (Control Unit)	96
Diagnosis Precaution	53	Inspection 4 Steering Angle Sensor and Circuit Between Steering Angle Sensor and ABS Actuator and Electric Unit (Control Unit)	97
CAN SYSTEM	53	Inspection 5 Yaw Rate/Side/Decel G Sensor and Circuit Between Yaw Rate/Side/Decel G Sensor and ABS Actuator and Electric Unit (Control Unit)...	98
Precaution for Harness Repair	53	Inspection 6 Solenoid, VDC Switching Valve, Actu- ator Relay and Circuits	99
CAN SYSTEM	53	Inspection 7 Actuator Motor, Motor Relay, and Cir- cuit	101
PREPARATION	54	Inspection 8 Stop Lamp Switch and Circuit	102
Special Service Tools	54	Inspection 9 ABS Actuator and Electric Unit (Control Unit) Power Supply and Ground Circuit	103
Commercial Service Tools	54	Inspection 10 When "STEERING ANGLE SENSOR HAS NOT BEEN CORRECTED" Appears on Self- Diagnosis Results Display	104
ON-VEHICLE SERVICE	55	Inspection 11 Brake Fluid Level in Reservoir Tank, Communication Circuit Between ABS Actuator and Electric Unit (Control Unit) and Brake Fluid Level Switch	105
Adjustment of Steering Angle Sensor Neutral Posi- tion	55	Inspection 12 CAN Communications Lines, ABS Actuator and Electric Unit (Control Unit), Steering Angle Sensor System and CAN-LAN Converter ECU (CLC)	106
Calibration of Decel G Sensor	55	Inspection 13 ENGINE SIGNAL 1 - Engine System	107
GENERAL INFORMATION	57	Inspection 14 ENG SPEED SIG - Engine Speed Sig- nal	108
Fail-Safe	57	Inspection 15 ENG CHECK SIG - LAN Monitoring	110
ABS SYSTEM	57	Inspection 16 LAN SIGNAL 2 - LAN Communication Start Procedure Incomplete	111
VDC/TCS SYSTEM	57	Inspection 17 LAN COMM 1 - LAN Communication System Failure	112
Hydraulic Circuit Diagram	57	Inspection 18 LAN SIGNAL 3 - Continued Reception After LAN Communication Starts	113
ABS Function	58	Inspection 19 SLIP Indicator Lamp Does Not Come On When Ignition Switch is Turned On	113
TCS Function	58	Inspection 20 VDC OFF Indicator Lamp Does Not	
VDC Function	58		
System Diagram	59		
CAN COMMUNICATION	60		
System Description	60		
SYSTEM DIAGRAM	60		
TROUBLE DIAGNOSIS	61		
How to Proceed With Diagnosis	61		
BASIC CONCEPT	61		
DIAGNOSIS FLOWCHART	62		
ASKING COMPLAINTS	63		
EXAMPLE OF DIAGNOSIS SHEET	63		
Component Installation Location	64		
Schematic	65		
Wiring Diagram — VDC —	66		
ABS Actuator and Electric Unit (Control Unit) Input/ Output Signal Standard	72		
STANDARDS USING CIRCUIT TESTER AND OSCILLOSCOPE	72		
STANDARDS BY CONSULT-II	74		
CONSULT-II Functions	78		
CONSULT-II FUNCTION APPLICATION TABLE ..	78		
CONSULT-II BASIC OPERATION PROCEDURE	79		

Come On When Ignition Switch Is Turned On	115	Symptom 6 Vehicle Behaves Jerkily During VDC/ TCS/ABS Operation	125	A
Inspection 21 VDC OFF Switch Is Inoperative	116	Symptom 7 Poor Acceleration	126	
Inspection 22 CAN-LAN Converter Power Supply Circuit	117	REMOVAL AND INSTALLATION	128	B
Inspection 23 CAN CIRCUIT 1 - CAN Communi- cation System Failure	119	Front Wheel Sensor	128	
Inspection 24 CAN-LAN Converter (CLC) Control Unit	119	Rear Wheel Sensor	128	C
Inspection 25 ABS Warning Lamp Does Not Come On When Ignition Switch Is Turned On	119	Front Sensor Rotor	128	
Inspection 26 When "DECEL G-SENSOR" Appears on Self-Diagnosis Results Display	121	REMOVAL	128	D
Inspecting Components	121	INSTALLATION	129	
VDC OFF SWITCH	121	Rear Sensor Rotor	129	E
Symptom 1 ABS Works Frequently	122	REMOVAL	129	
Symptom 2 Unexpected Pedal Reaction	122	INSTALLATION	129	
Symptom 3 Long Stopping Distance	123	ABS Actuator and Electric Unit	130	
Symptom 4 ABS Does Not Work	123	REMOVAL	130	
Symptom 5 Pedal Vibration and Noise	124	INSTALLATION	130	
		Yaw Rate/Side/Decel G Sensor	131	
		Steering Angle Sensor	131	
		CAN-LAN Converter (CLC)	131	BRC

PRECAUTIONS

Precautions for Supplemental Restraint System (SRS) “AIR BAG” and “SEAT BELT PRE-TENSIONER”

EFS003GF

The Supplemental Restraint System such as “AIR BAG” and “SEAT BELT PRE-TENSIONER”, used along with a front seat belt, helps to reduce the risk or severity of injury to the driver and front passenger for certain types of collision. This system includes seat belt switch inputs and dual stage front air bag modules. The SRS system uses the seat belt switches to determine the front air bag deployment, and may only deploy one front air bag, depending on the severity of a collision and whether the front occupants are belted or unbelted. Information necessary to service the system safely is included in the SRS and SB section of this Service Manual.

WARNING:

- To avoid rendering the SRS inoperative, which could increase the risk of personal injury or death in the event of a collision which would result in air bag inflation, all maintenance must be performed by an authorized NISSAN/INFINITI dealer.
- Improper maintenance, including incorrect removal and installation of the SRS, can lead to personal injury caused by unintentional activation of the system. For removal of Spiral Cable and Air Bag Module, see the SRS section.
- Do not use electrical test equipment on any circuit related to the SRS unless instructed to in this Service Manual. SRS wiring harnesses can be identified by yellow and/or orange harnesses or harness connectors.

Precautions for Brake System

EFS003GG

- Recommended fluid is brake fluid “DOT 3”.
- Never reuse drained brake fluid.
- Be careful not to splash brake fluid on painted areas such as body. If brake fluid is splashed, wipe it off and flush area with water immediately.
- Never use mineral oils such as gasoline or kerosene to clean. They will ruin rubber parts and cause improper operation.
- Using a flare nut torque wrench, securely tighten brake tube flare nuts.
- Brake system is an important safety part. If a brake fluid leak is detected, always disassemble the affected part. If a malfunction is detected, replace part with a new one.
- Before working, turn ignition switch OFF and disconnect electrical connectors of ABS actuator and electric unit (control unit) or battery terminals.
- When installing brake piping, be sure to check torque.

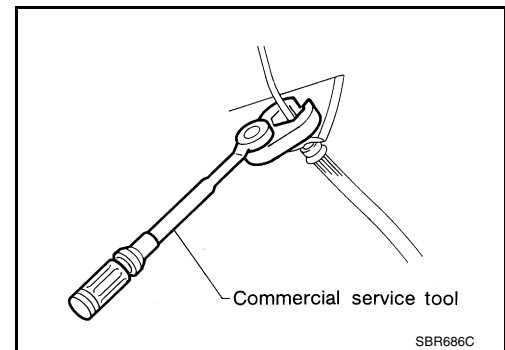

Wiring Diagrams and Trouble Diagnosis

EFS003GH

When you read wiring diagrams, refer to the following:

- [GI-13, "How to Read Wiring Diagrams"](#)
- [PG-9, "POWER SUPPLY ROUTING"](#)

When you perform trouble diagnosis, refer to the following:

- [GI-9, "HOW TO FOLLOW TEST GROUPS IN TROUBLE DIAGNOSES"](#)
- [GI-25, "How to Perform Efficient Diagnosis for an Electrical Incident"](#)

Check for any Service bulletins before servicing the vehicle.

Precautions for Brake Control

EFS003GI

- During ABS operation, brake pedal lightly vibrates and a mechanical noise may be heard. This is normal.
- Just after starting vehicle after ignition switch ON, brake pedal may vibrate or motor operating noise may be heard from engine compartment. This is a normal status of operation check.
- Stopping distance may be longer than that of vehicles without ABS when vehicle drives on rough, gravel, or snow-covered (fresh, deep snow) roads.

PRECAUTIONS

[ABS]

- When an error is indicated by ABS or another warning lamp, collect all necessary information from customer (what symptoms are present under what conditions) and check for simple causes before starting diagnostic servicing. Besides electrical system inspection, check booster operation, brake fluid level, and oil leaks. A
- If tire size and type are used in an improper combination, or brake pads are not Genuine NISSAN parts, stopping distance or steering stability may deteriorate. B
- If there is a radio, antenna, or antenna lead-in wire (including wiring) near control module, ABS function may have a malfunction or error. C
- If aftermarket parts (car stereo, CD player, etc.) have been installed, check for incidents such as harness pinches, open circuits, and improper wiring. D

D

E

BRC

G

H

I

J

K

L

M

PREPARATION

[ABS]

PFP:00002

EFS003GJ

PREPARATION

Special Service Tools

The actual shapes of Kent-Moore tools may differ from those of special service tools illustrated here.

Tool number (Kent-Moore No.) Tool name	Description
KV40106500 (JS25852-B) Wheel bearing puller	Removing rear wheel sensor rotor
(J-45741) ABS active wheel sensor tester	Checking operation of ABS active wheel sensor

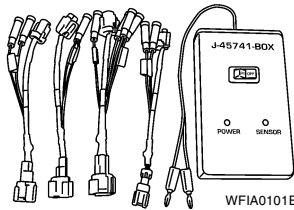
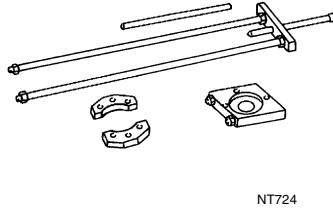

Commercial Service Tools

EFS003GK

Tool name	Description
1 Flare nut crowfoot 2 Torque wrench	Removing and installing each brake piping a: 10 mm (0.39 in)
Rear wheel sensor rotor drift	Installing rear wheel sensor rotor a: 75 mm (2.95 in) dia. b: 63 mm (2.48 in) dia.

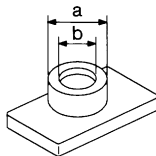
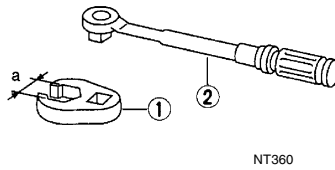

GENERAL INFORMATION

PFP:00000

EFS003GL

**Fail-Safe
ABS SYSTEM**

If a malfunction occurs in electrical system, ABS warning lamp in combination meter turns ON. In this condition, the fail-safe function puts ABS and electronic brake force distribution (EBD) into one of the following conditions.

1. Only EBD operates.
2. ABS and EBD do not operate. All 4 wheels operate as normal brakes.

NOTE:

In step 1 shown above, self-diagnosis when ignition switch is turned ON and when vehicle starts at initial time is carried out. ABS self-diagnosis noise may be heard as usual.

CAUTION:

If fail-safe mode is initiated, carry out self-diagnosis for ABS control system.

Hydraulic Circuit Diagram

EFS003GM

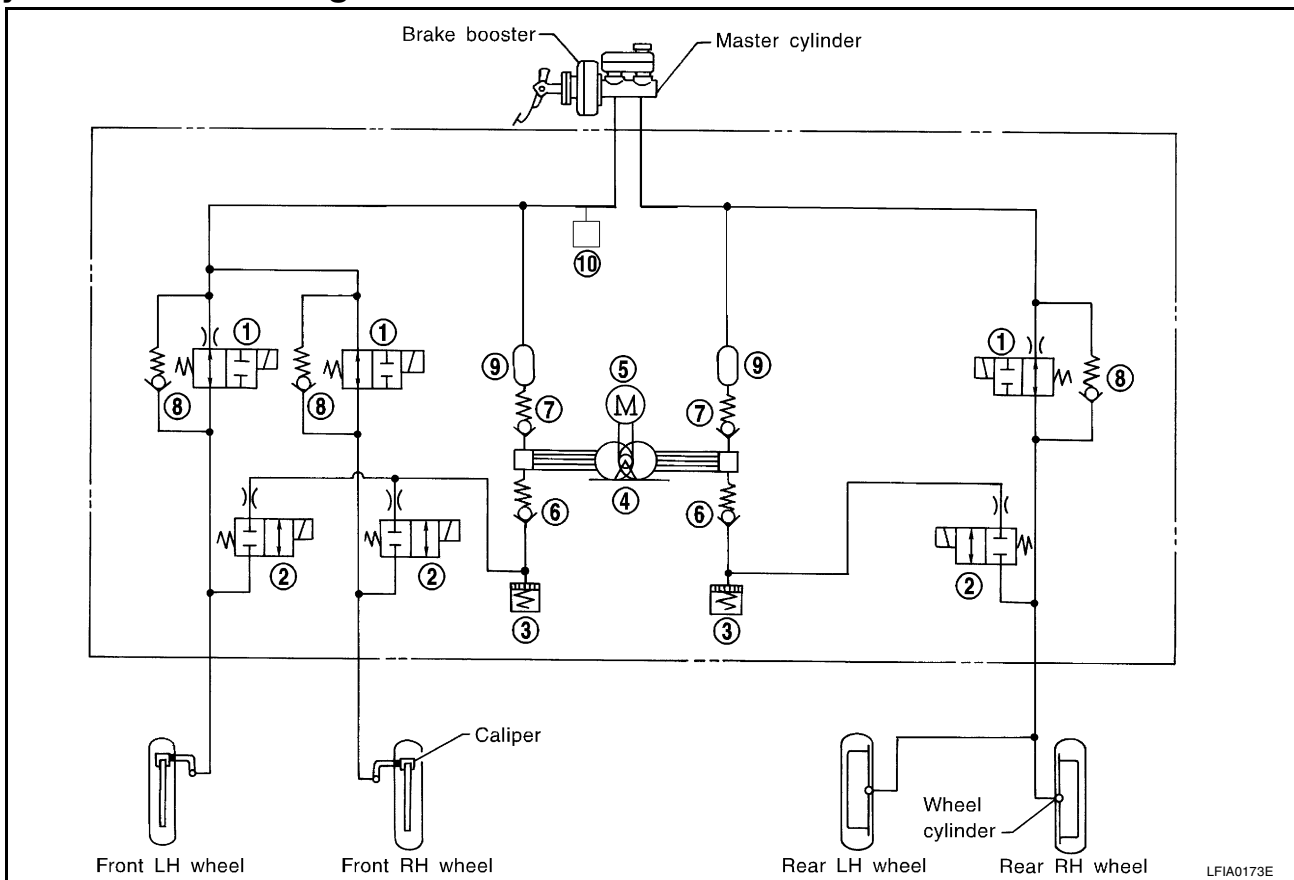

BRC

- | | | |
|-------------------------|--------------------------|----------------|
| 1. Inlet solenoid valve | 2. Outlet solenoid valve | 3. Reservoir |
| 4. Pump | 5. Motor | 6. Inlet valve |
| 7. Outlet valve | 8. Bypass check valve | 9. Damper |
| 10. Pressure switch | | |

CAUTION:

- When installing parts, avoid twist and fracture conditions.
- Make sure there is no interference with other parts when turning steering both clockwise and counterclockwise.
- Brake system is an important safety part. If a brake fluid leak is detected, always disassemble the affected part. If a malfunction is detected, replace it with a new one.

ABS Function

EFS003GN

1. During ABS operation, brake pedal lightly vibrates and a mechanical noise may be heard. This is normal.

G
H
I
J
K
L
M

GENERAL INFORMATION

[ABS]

2. When starting engine, or just after starting vehicle, brake pedal may vibrate or motor operating noises may be heard from engine compartment. This is a normal status of operation check.
3. Stopping distance may be longer than that of vehicles without ABS when vehicle drives on rough, gravel, or snow-covered (fresh, deep snow) roads.
4. EBD is integrated in ABS system.

System Diagram

EF5003GO

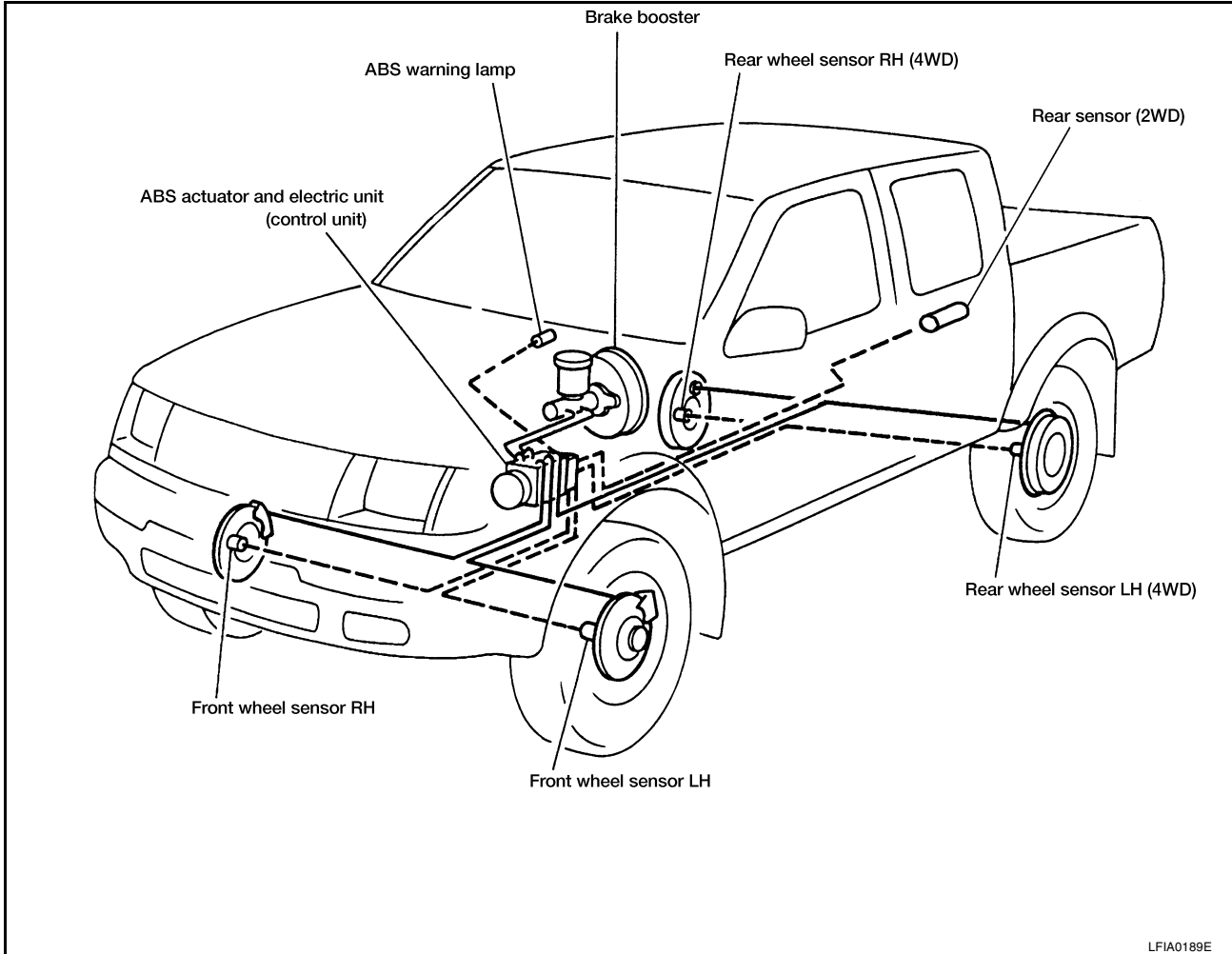

TROUBLE DIAGNOSIS

How to Proceed With Diagnosis
BASIC CONCEPT

- Most important point to perform diagnosis is to understand systems (control and mechanism) in vehicle thoroughly.

- It is also important to clarify customer complaints before inspection.
First of all, reproduce symptom, and understand it fully.
Ask customer about his/her complaints carefully. In some cases, it will be necessary to check symptom by driving vehicle with customer.

NOTE:

Customers are not professionals. Do not assume "maybe customer means..." or "maybe customer mentioned this symptom".

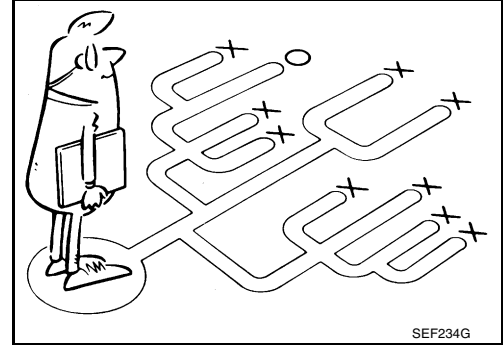

SEF234G

- It is essential to check symptoms right from beginning in order to repair a malfunction completely.
For an intermittent malfunction, it is important to reproduce symptom based on interview with customer and past examples. Do not perform inspection on ad hoc basis. Most intermittent malfunctions are caused by poor contacts. In this case, it will be effective to shake suspected harness or connector by hand. When repairs are performed without any symptom check, no one can judge if malfunction has actually been eliminated.

- After diagnosis, make sure to carry out "erase memory". Refer to [BRC-79. "Operation Procedure"](#).
- For an intermittent malfunction, move harness or harness connector by hand to check poor contact or false open circuit.
- Always read "GI General Information" to confirm general precautions.

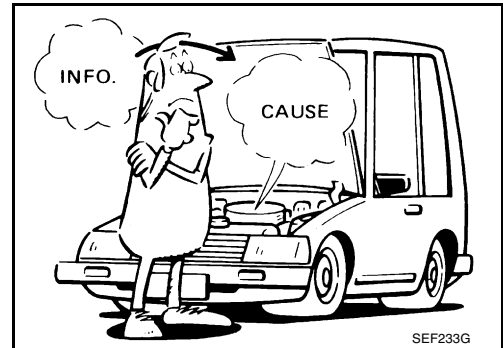

SEF233G

A

B

C

D

E

BRC

G

H

I

J

K

L

M

TROUBLE DIAGNOSIS

[ABS]

DIAGNOSIS FLOWCHART

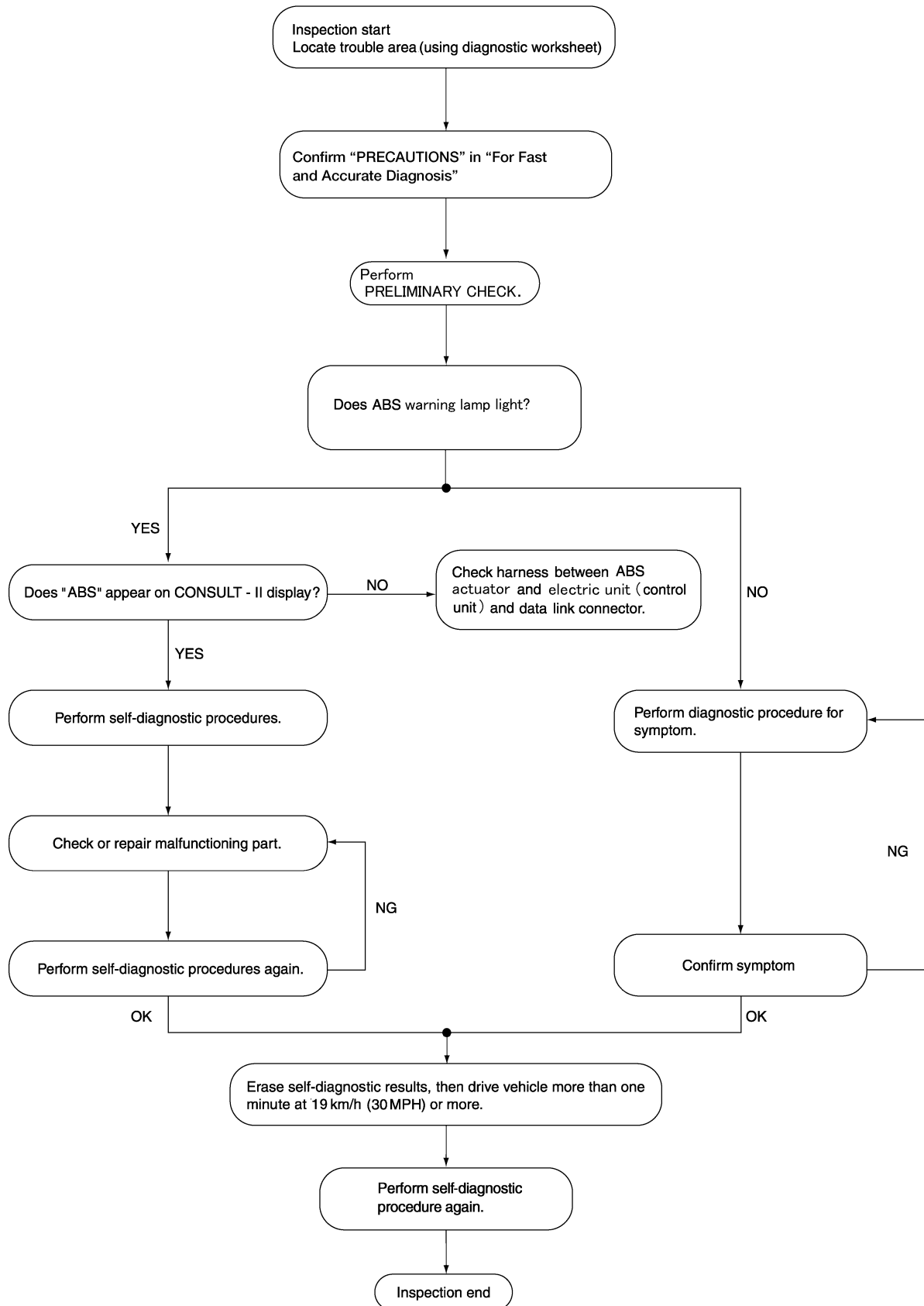

LFIA0175E

TROUBLE DIAGNOSIS

[ABS]

ASKING COMPLAINTS

- Complaints about malfunction vary depending on each person. It is important to clarify customer complaints.
- Ask customer about what symptoms are present and under what conditions. Use information to reproduce symptom while driving.
- It is also important to use diagnosis sheet so as not to miss information.

KEY POINTS

WHAT Vehicle model
WHEN Date, Frequencies
WHERE Road conditions
HOW Operating conditions,
 Weather conditions,
 Symptoms

SBR339B

EXAMPLE OF DIAGNOSIS SHEET

Customer name MR/MS	Model & Year		VIN
Engine #	Trans.		Mileage
Incident Date	Manuf. Date		In Service Date
Symptoms	<input type="checkbox"/> Noise and vibration (from engine compartment) <input type="checkbox"/> Noise and vibration (from axle)	<input type="checkbox"/> Warning / Indicator activate	<input type="checkbox"/> Firm pedal operation Large stroke pedal operation
	<input type="checkbox"/> ABS does not work (Wheels lock when braking)	<input type="checkbox"/> ABS does not work (wheels slip when braking)	<input type="checkbox"/> Lack of sense of acceleration
Engine conditions	<input type="checkbox"/> When starting <input type="checkbox"/> After starting		
Road conditions	<input type="checkbox"/> Low friction road (<input type="checkbox"/> Snow <input type="checkbox"/> Gravel <input type="checkbox"/> Other) <input type="checkbox"/> Bumps / potholes		
Driving conditions	<input type="checkbox"/> Full-acceleration <input type="checkbox"/> High speed cornering <input type="checkbox"/> Vehicle speed: Greater than 10 km/h (6 MPH) <input type="checkbox"/> Vehicle speed: 10 km/h (6 MPH) or less <input type="checkbox"/> Vehicle is stopped		
Applying brake conditions	<input type="checkbox"/> Suddenly <input type="checkbox"/> Gradually		
Other conditions	<input type="checkbox"/> Operation of electrical equipment <input type="checkbox"/> Shift change <input type="checkbox"/> Other descriptions		

LFIA0176E

Component Installation Location

EFS003G0

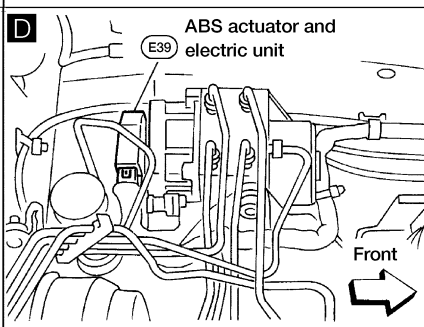
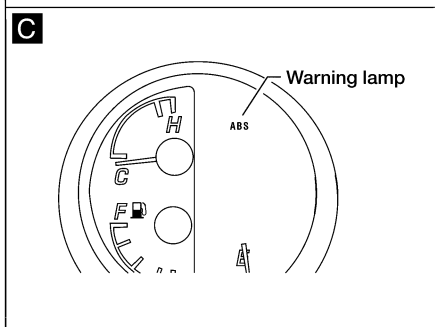
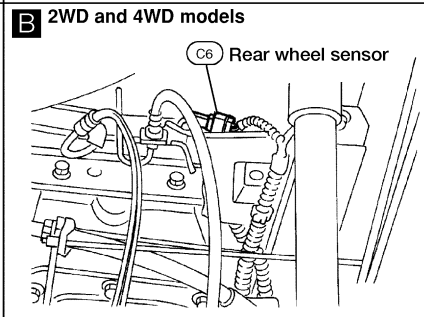
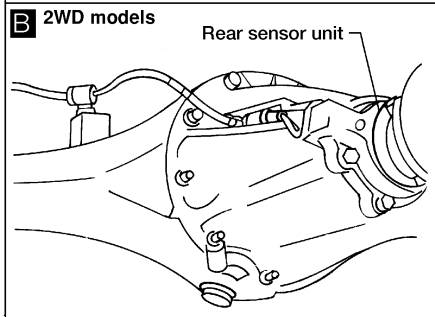
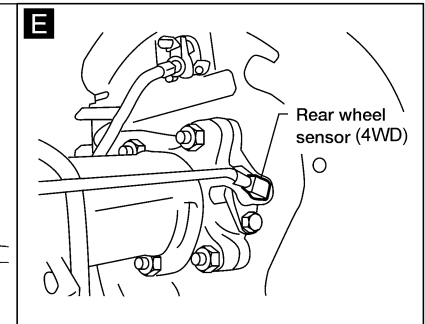
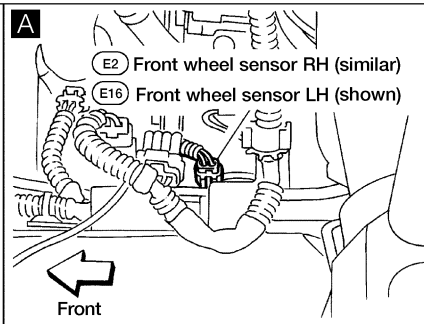
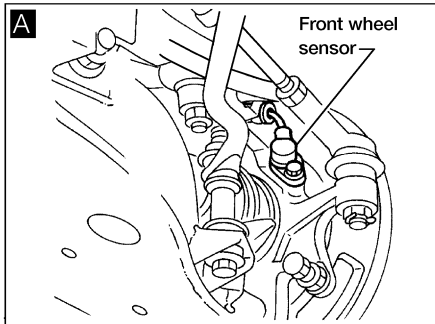
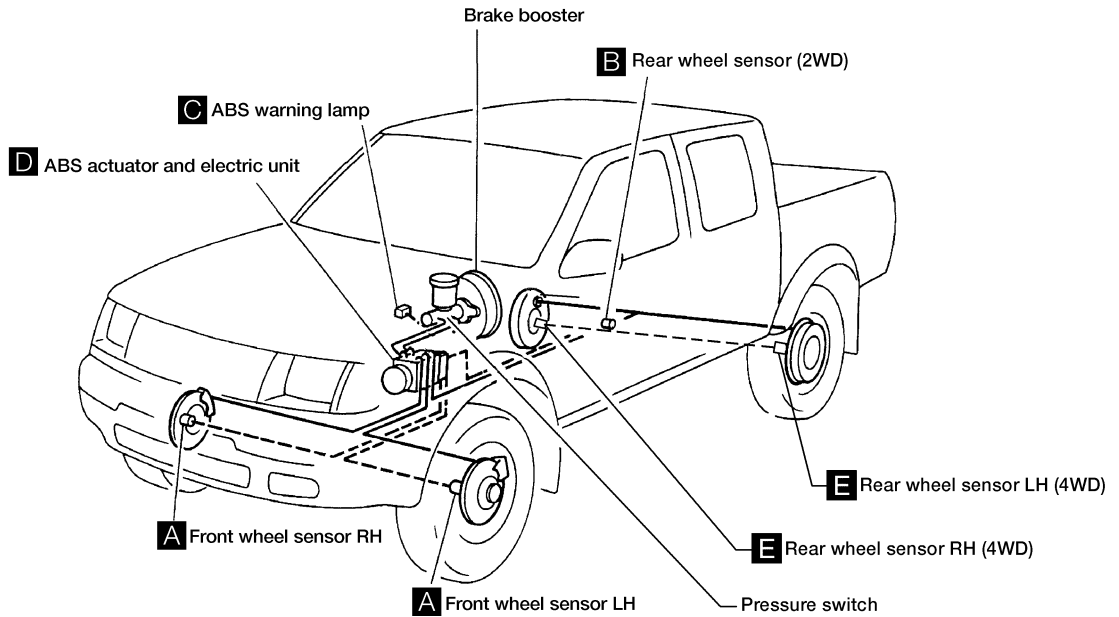

LFIA0187E

Schematic
2-WHEEL DRIVE

A
B
C
D
E
BRC
G
H
I
J
K
L
M

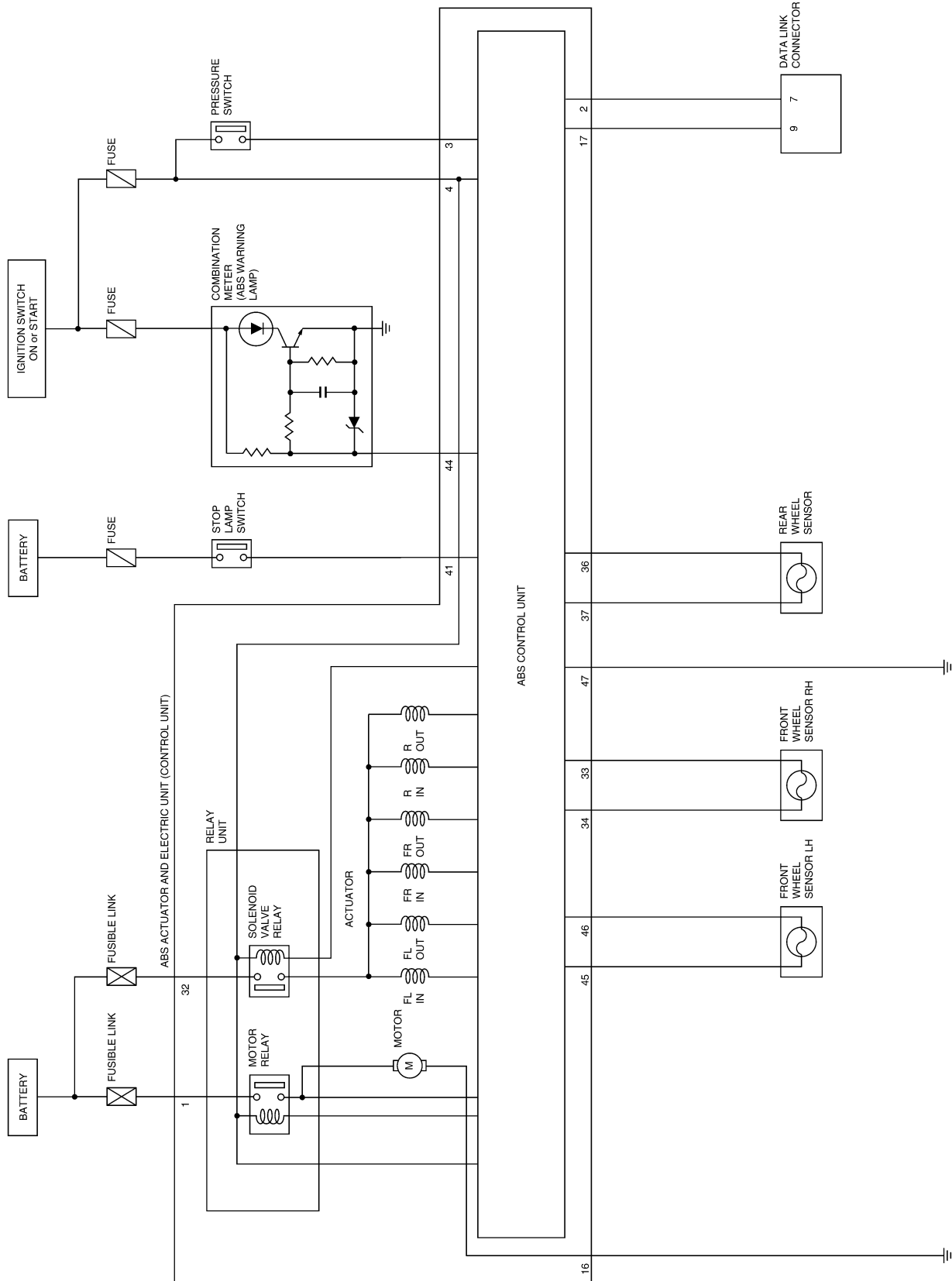

4-WHEEL DRIVE

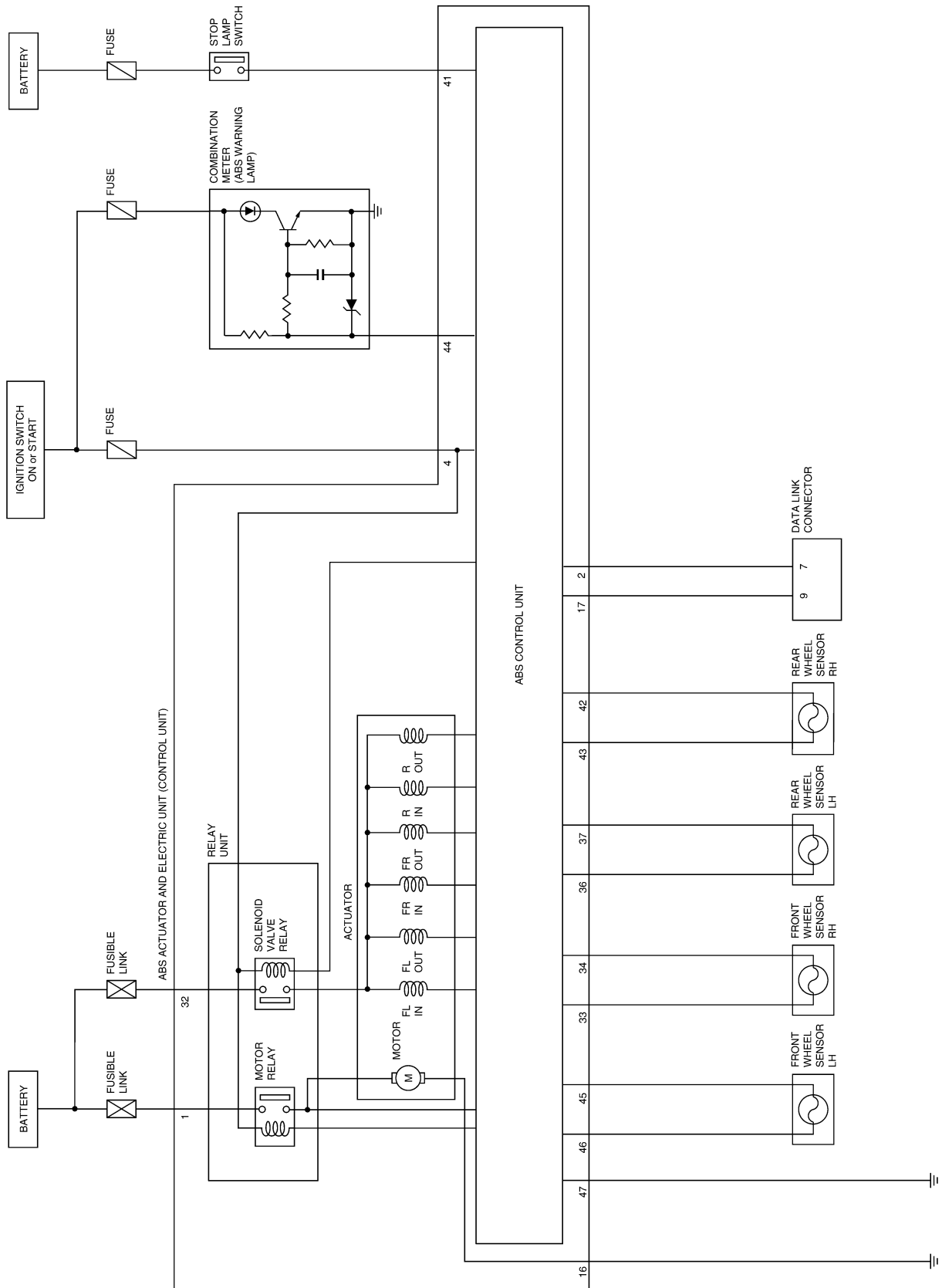

TROUBLE DIAGNOSIS

[ABS]

Wiring Diagram — ABS — 2WD —

EFS003GS

BRC-ABS-01

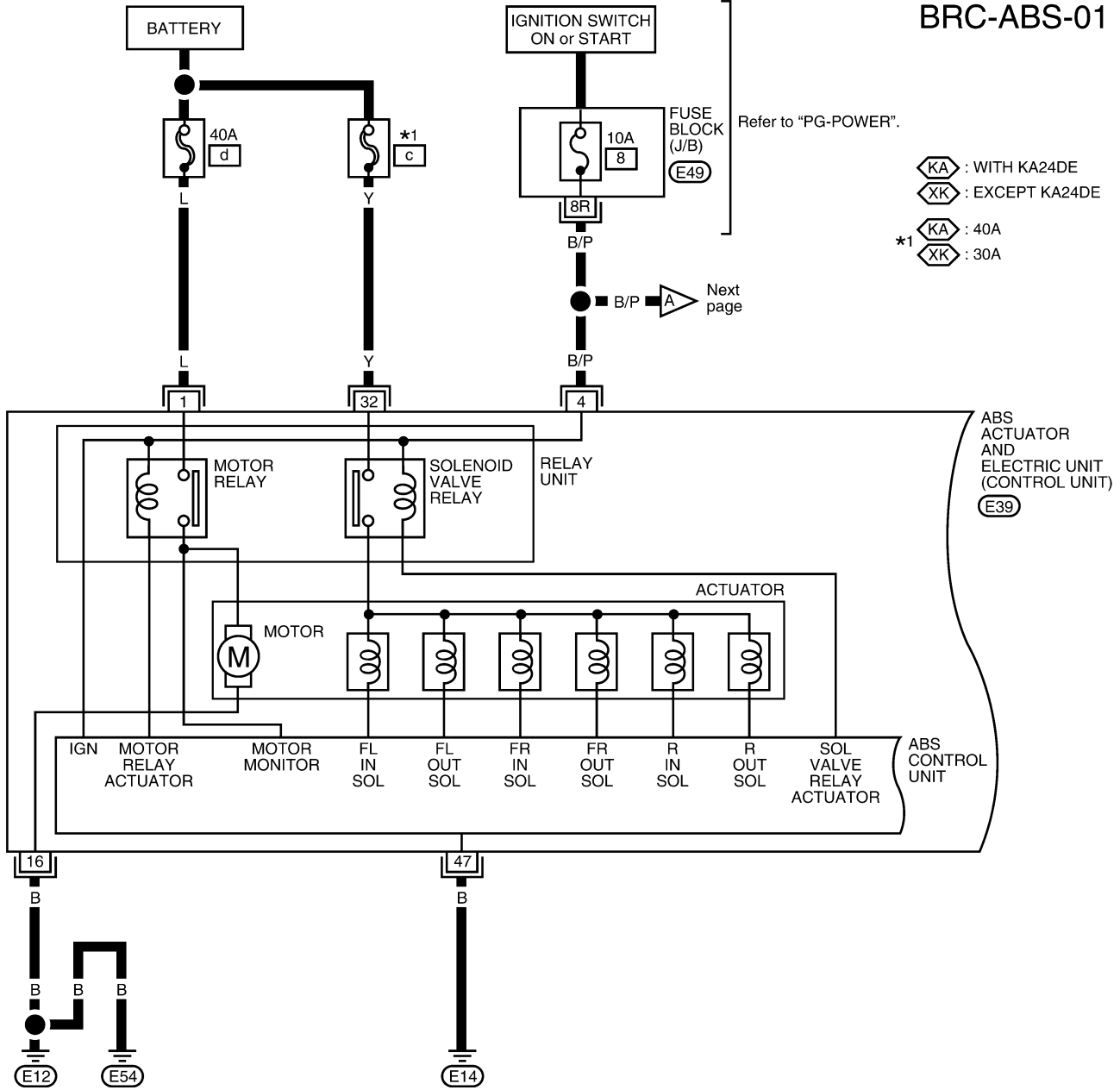

A
B
C
D
E
BRC
G
H
I
J
K
L
M

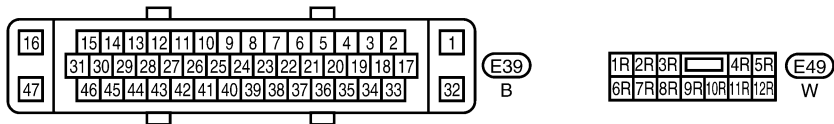

LFWA0018E

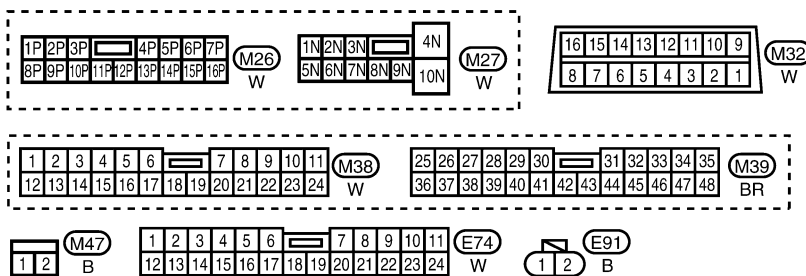
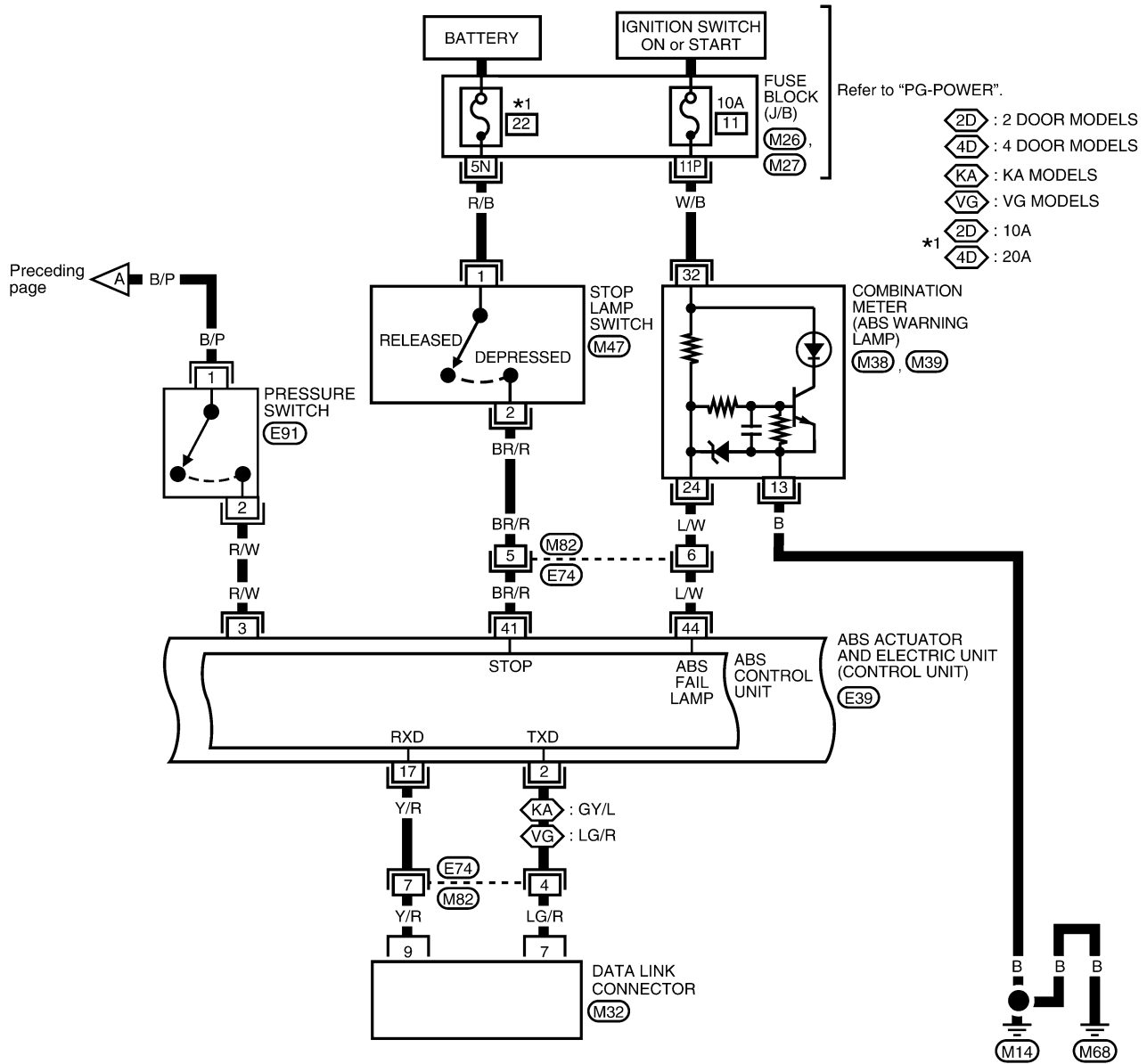

TROUBLE DIAGNOSIS

[ABS]

BRC-ABS-03

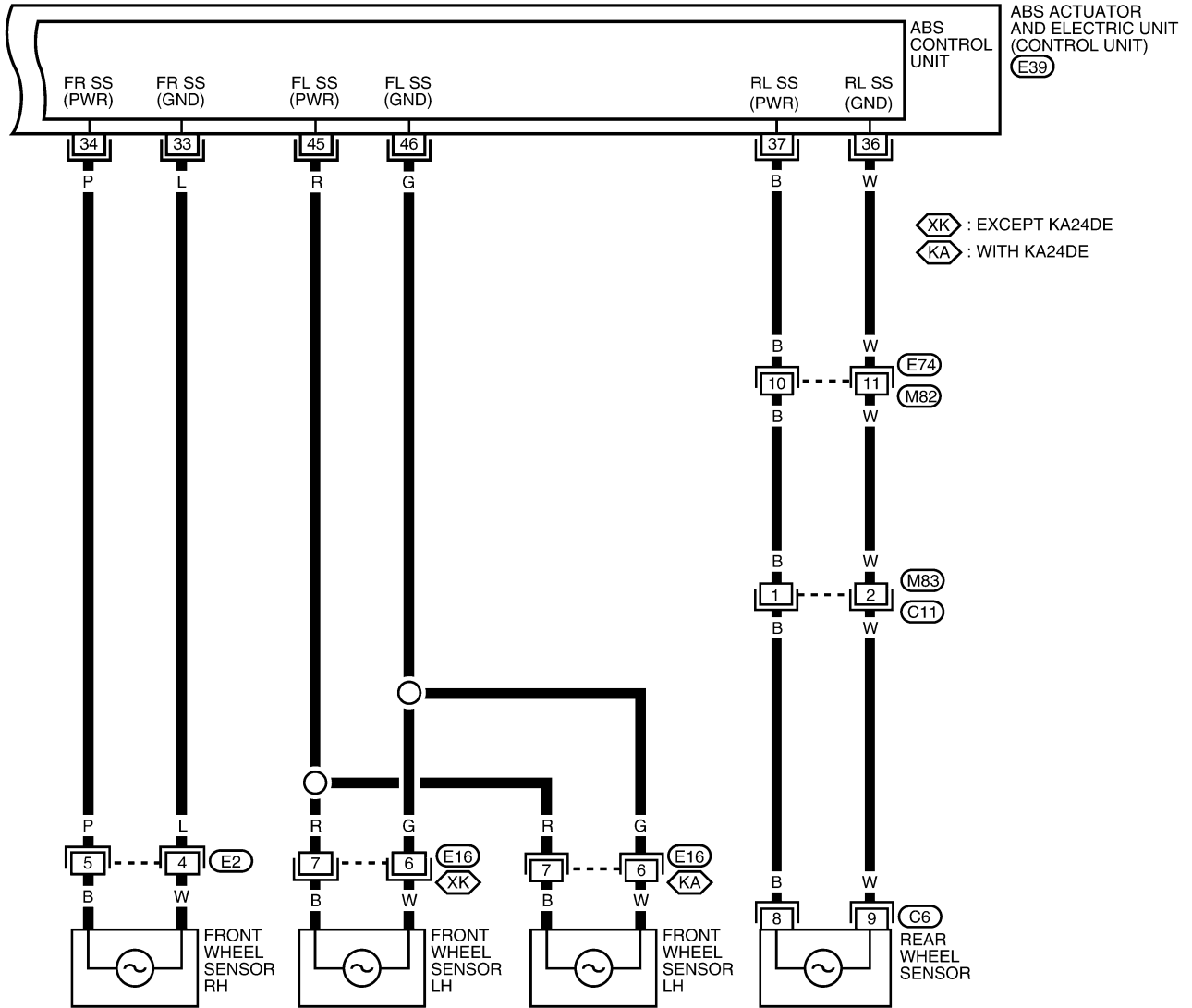

A
B
C
D
E
BRC
G
H
I
J
K
L
M

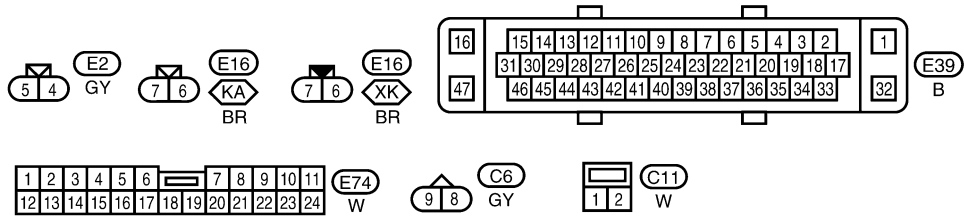

LFWA0020E

TROUBLE DIAGNOSIS

[ABS]

Wiring Diagram — ABS — 4WD —

EFS003GT

BRC-ABS-04

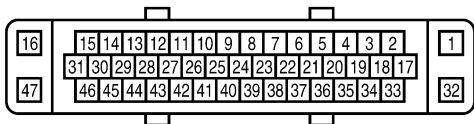
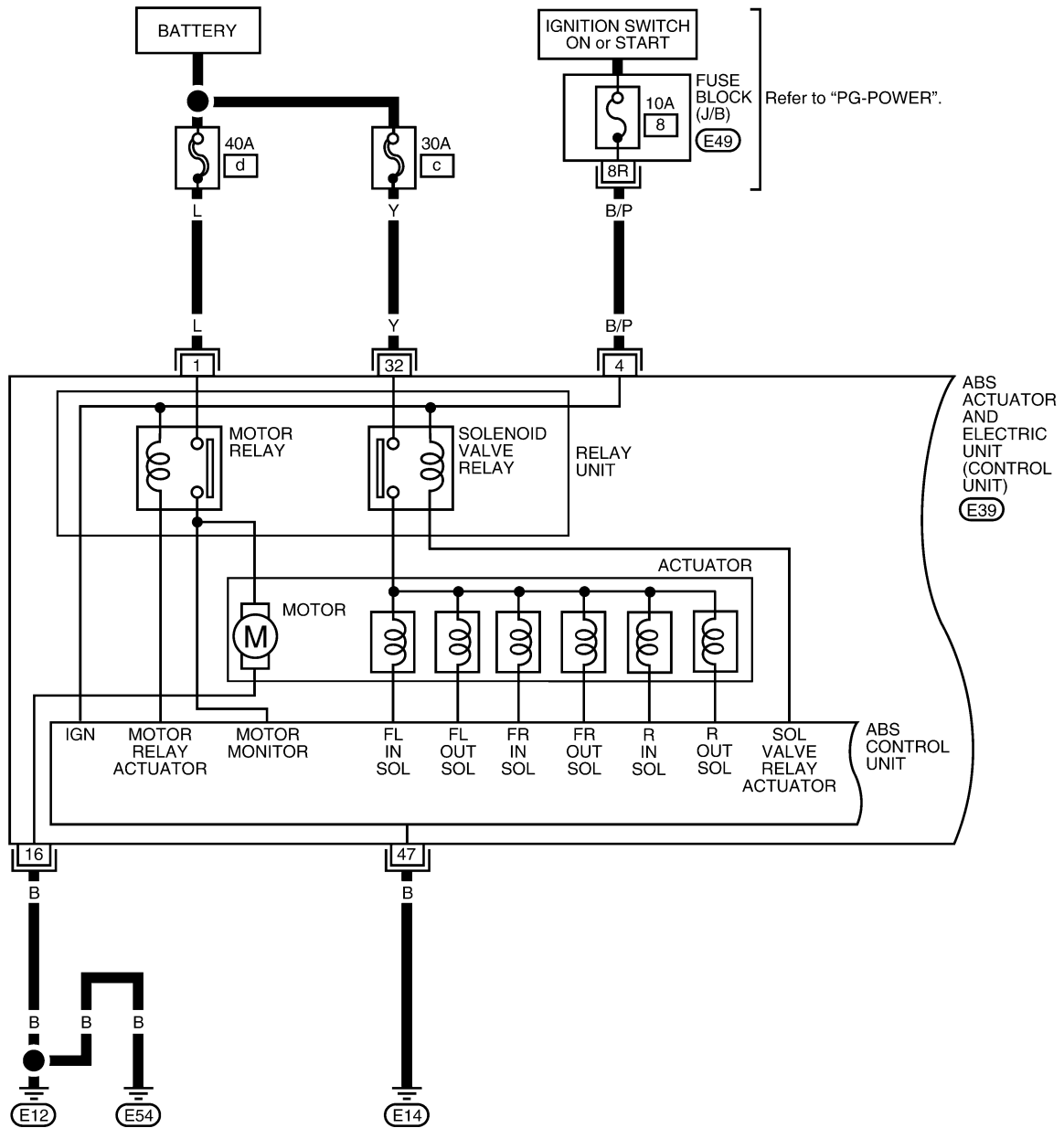

LFWA0022E

TROUBLE DIAGNOSIS

[ABS]

BRC-ABS-05

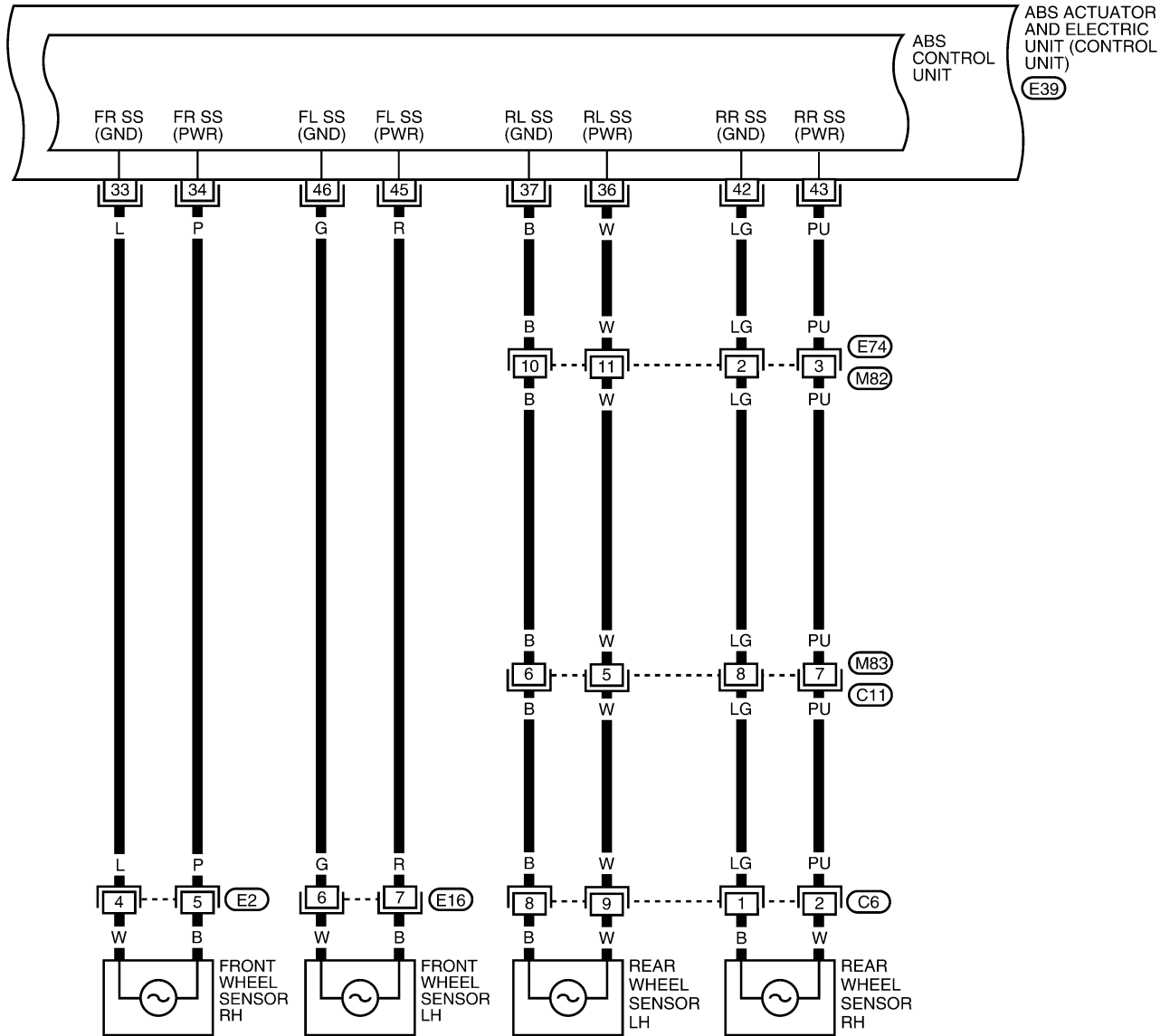

A
B
C
D
E
BRC
G
H
I
J
K
L
M

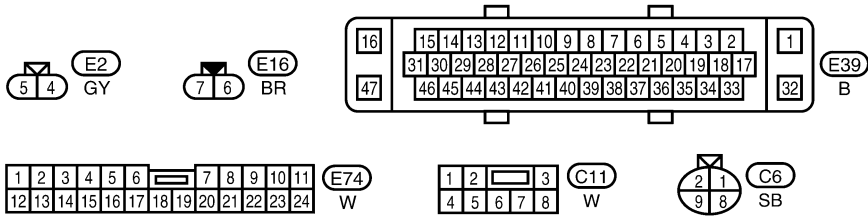

TROUBLE DIAGNOSIS

[ABS]

BRC-ABS-06

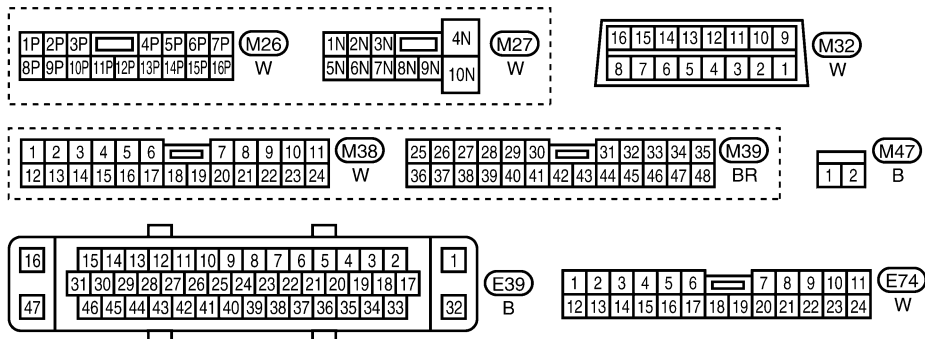
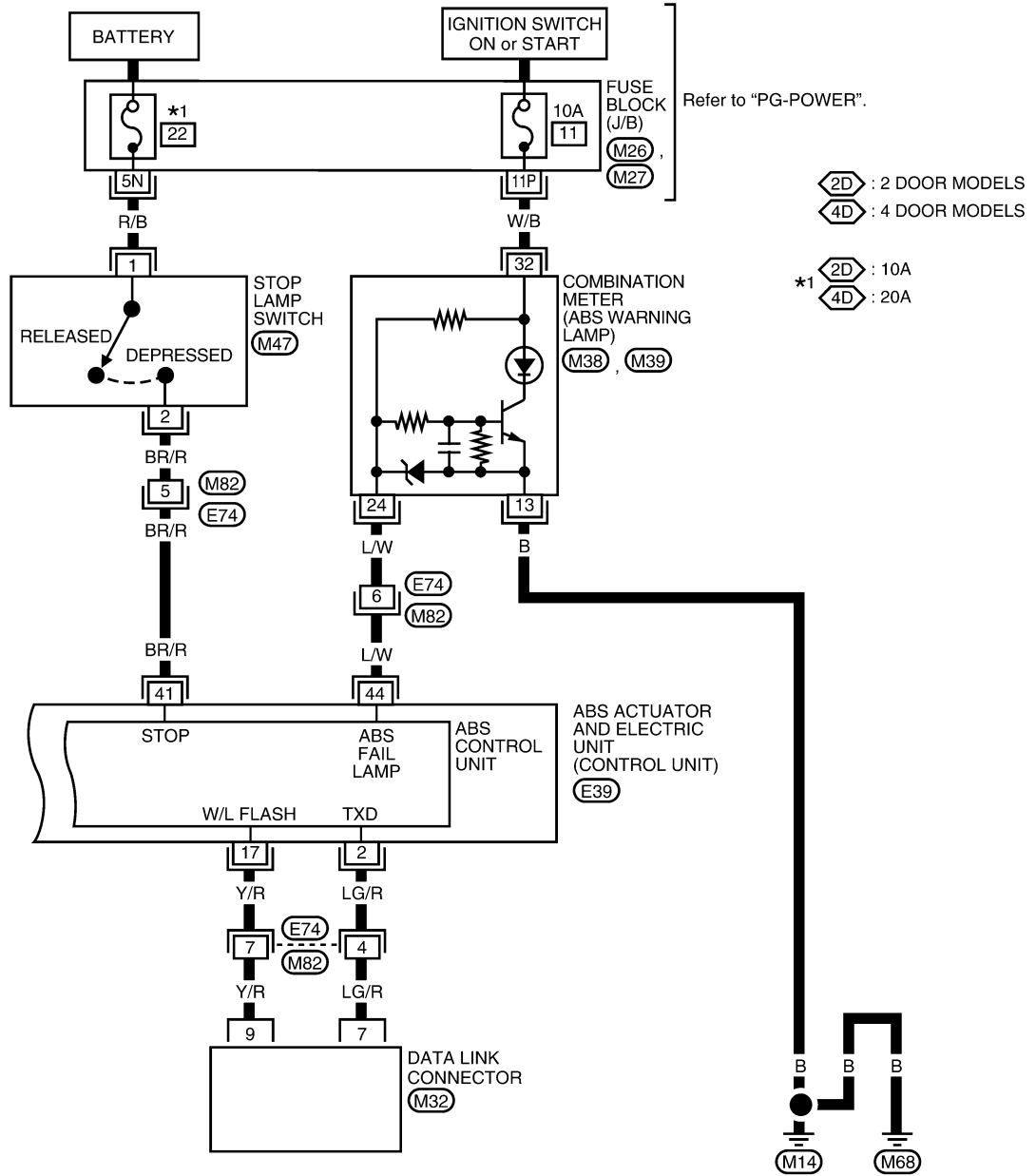

LFWA0024E

TROUBLE DIAGNOSIS

[ABS]

ABS Actuator and Electric Unit (Control Unit) Input/Output Signal Standard EFS003GU STANDARDS USING CIRCUIT TESTER AND OSCILLOSCOPE

CAUTION:

Connect ABS actuator and electric unit (control unit) connector, and then turn ignition switch ON.

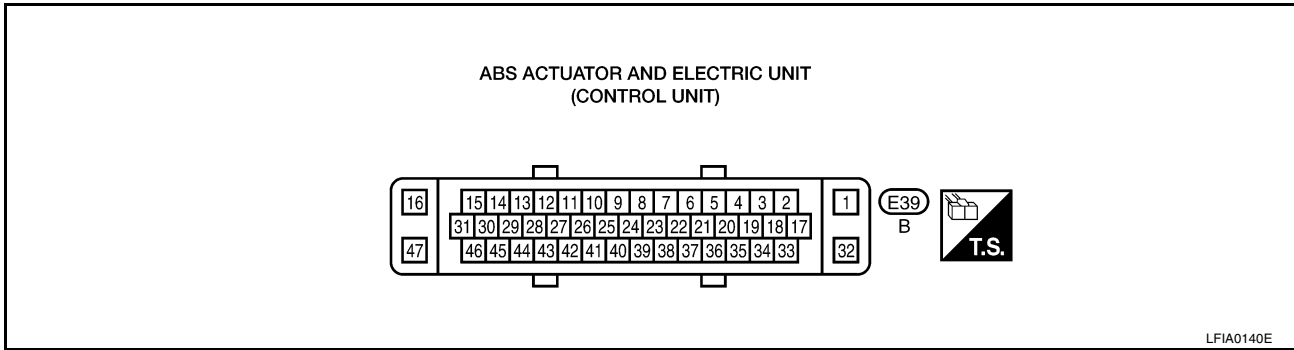

Measurement terminal		Measuring point	Standard value (Note 1)		Note: Error inspection checklist
+	-				
1		Actuator motor	Actuator motor being driven	Approx. 12V	BRC-39, "Inspection 5 Actuator Motor, Motor Relay, and Circuit"
			Actuator motor stopped	Approx. 12V	
3		Pressure switch (2WD models)	Brake pedal depressed	Approx. 12V	BRC-37, "Inspection 3 Pressure Switch and Circuit Between Pressure Switch and ABS Actuator and Electric Unit (Control Unit)"
			Brake pedal not depressed	Approx. 0V	
4	Body ground	Power supply	Ignition switch ON	Approx. 12V	BRC-41, "Inspection 7 ABS Actuator and Electric Unit (Control Unit) Power Supply and Ground Circuit"
16		Ground	—	Approx. 0Ω	BRC-41, "Inspection 7 ABS Actuator and Electric Unit (Control Unit) Power Supply and Ground Circuit"
32		Solenoid valve	Valve is active	Approx. 12V	BRC-38, "Inspection 4 Solenoid Valve and Circuits"
			Valve is inactive	Approx. 12V	
—	—	Front RH wheel sensor	Note 3	—	BRC-35, "Inspection 1 Wheel Sensor System"
—	—	Rear LH wheel sensor (4WD) Rear sensor (2WD)			
41	Body ground	Stop lamp signal	Brake pedal depressed	Approx. 12V	BRC-40, "Inspection 6 Stop Lamp Switch and Circuit"
			Brake pedal not depressed	Approx. 0V	
—	—	Rear RH wheel sensor (4WD)	Note 3	—	BRC-35, "Inspection 1 Wheel Sensor System"

TROUBLE DIAGNOSIS

[ABS]

Measurement terminal		Measuring point	Standard value (Note 1)		Note: Error inspection checklist
+	-				
44	Body ground	ABS warning lamp	ABS warning lamp ON (Note 2)	Approx. 12V	BRC-42, "Inspection 8 ABS Warning Lamp Does Not Come On When Ignition Switch Is Turned On"
			ABS warning lamp OFF (Note 2)	Approx. 0V	
—	—	Front LH wheel sensor	Note 3	—	BRC-35, "Inspection 1 Wheel Sensor System"
47	Body ground	Ground	—	Approx. 0Ω	BRC-41, "Inspection 7 ABS Actuator and Electric Unit (Control Unit) Power Supply and Ground Circuit"

Note 1: When standard value is checked using a circuit tester for voltage measurement, care must be taken to avoid damage to connector terminals.

Note 2: ON/OFF timing of ABS warning lamp

ON: For approximately 2 seconds after ignition switch is turned ON, or when a malfunction is detected.

OFF: Approximately 2 seconds after ignition switch is turned ON (when system is in normal operation).

Note 3: Confirm tire pressure is normal.

TROUBLE DIAGNOSIS

[ABS]

STANDARDS BY CONSULT-II

CAUTION:

Items displayed are data calculated by the control unit and may indicate normal operation even if output circuit (harness) is open or shorted.

Monitor item	Display content	Data monitor		Note: Error inspection checklist
		Condition	Reference value in normal operation	
FR RH SENSOR FR LH SENSOR RR RH SENSOR (4WD) RR LH SENSOR (4WD) REAR SENSOR (2WD)	Wheel speed	Vehicle stopped	0 [km/h (MPH)]	BRC-35. "Inspection 1 Wheel Sensor System"
		Vehicle running (Note 1)	Almost in accordance with speedometer display (within ±10%)	
PRESS SW	Brake fluid pressure detected by pressure switch (2WD models)	With ignition switch turned ON and brake pedal released	OFF	BRC-37. "Inspection 3 Pressure Switch and Circuit Between Pressure Switch and ABS Actuator and Electric Unit (Control Unit)"
		With ignition switch turned ON and brake pedal depressed	ON	
BATTERY VOLT	Battery voltage supplied to ABS actuator and electric unit (control unit)	Ignition switch ON	10 to 16V	BRC-41. "Inspection 7 ABS Actuator and Electric Unit (Control Unit) Power Supply and Ground Circuit"
STOP LAMP SW	Brake pedal operation	Brake pedal depressed	ON	BRC-40. "Inspection 6 Stop Lamp Switch and Circuit"
		Brake pedal not depressed	OFF	
ABS WARN LAMP	ABS warning lamp ON condition (Note 2)	ABS warning lamp ON	ON	BRC-42. "Inspection 8 ABS Warning Lamp Does Not Come On When Ignition Switch Is Turned On"
		ABS warning lamp OFF	OFF	
MOTOR RELAY	Operation status of motor and motor relay	Ignition switch ON or engine running (ABS not operated)	OFF	BRC-39. "Inspection 5 Actuator Motor, Motor Relay, and Circuit"
		Ignition switch ON or engine running (ABS operated)	ON	
ACTUATOR RLY	Actuator relay operation status	Vehicle stopped (Ignition switch ON)	OFF	BRC-39. "Inspection 5 Actuator Motor, Motor Relay, and Circuit"
		Vehicle stopped (Engine running)	ON	
FR LH IN SOL FR LH OUT SOL FR RH IN SOL FR RH OUT SOL RR RH IN SOL RR RH OUT SOL RR LH IN SOL RR LH OUT SOL	Solenoid valve operation	Actuator (solenoid) is active ("ACTIVE TEST" with CONSULT-II) or actuator relay is inactive (in fail-safe mode).	ON	BRC-38. "Inspection 4 Solenoid Valve and Circuits"
		When actuator (solenoid) is not active and actuator relay is active (ignition switch ON).	OFF	
ABS FAIL SIG EBD FAIL SIG	Fail signal status	ABS fail EBD fail	ON	ABS system EBD system
		ABS normal EBD normal	OFF	

Note 1: Confirm tire pressure is normal.

Note 2: ON/OFF timing of ABS warning lamp

ON: For approximately 2 seconds after ignition switch is turned ON, or when a malfunction is detected.

OFF: Approximately 2 seconds after ignition switch is turned ON (when system is in normal operation).

TROUBLE DIAGNOSIS

[ABS]

EFS003GV

CONSULT-II Functions CONSULT-II FUNCTION APPLICATION TABLE

CAUTION:

“FUNCTION TEST” shall not be used for diagnosis. For details, refer to separately supplied “CONSULT-II Instruction Manual (FUNCTION TEST)”.

Item	Self-diagnosis	Data monitor	Active test
Wheel sensors	×	×	—
Stop lamp switch	×	×	—
Solenoid valves	×	×	×
Pressure switch (2WD models)	×	×	—
Actuator relay	×	×	—
Motor relay	×	×	—
ABS warning lamp	—	×	—
Battery voltage	×	×	—
ABS actuator and electric unit (control unit)	×	—	—
ABS actuator motor	×	—	×

×:Applicable

—:Not applicable

CONSULT-II BASIC OPERATION PROCEDURE

1. Turn ignition switch OFF.
2. Connect CONSULT-II and CONSULT-II CONVERTER to the data link connector.

CAUTION:

If CONSULT-II is used with no connection of CONSULT-II CONVERTER, malfunctions might be detected in self-diagnosis depending on control unit which carry out CAN communication.

3. Turn ignition switch ON.

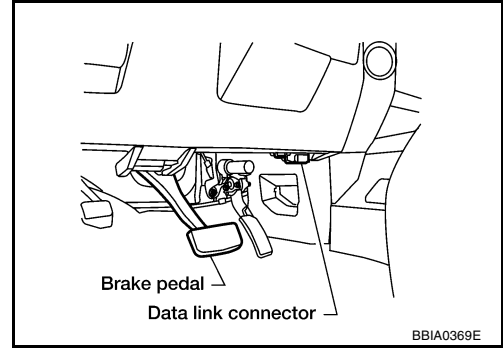

4. Touch "START (NISSAN BASED VHCL)".

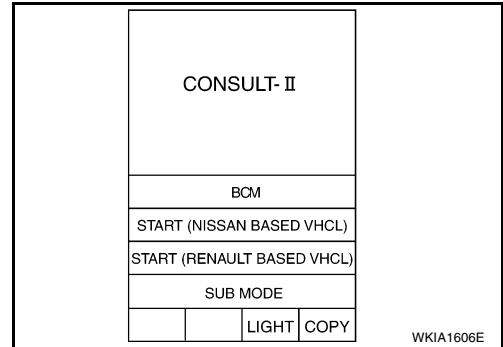

5. Touch "ABS" in the "Diagnosis System Selection" screen.
If "ABS" is not indicated, go to [GI-35. "CONSULT-II CHECKING SYSTEM"](#).

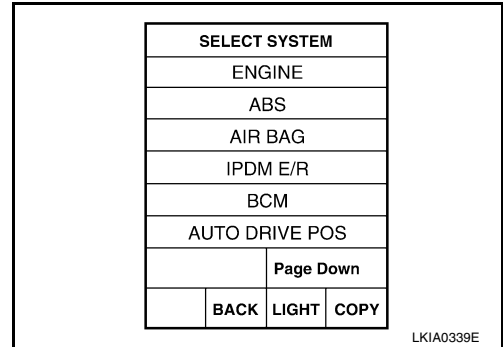

6. Select the required diagnostic location from the "Diagnosis Mode Selection" screen.
For further information, see the CONSULT-II Operation Manual.

A
B
C
D
E
BRC
G
H
I
J
K
L
M

SELF-DIAGNOSIS**Description**

If a malfunction is detected in system, ABS warning lamp in combination meter turns ON. In this case, perform self-diagnosis as follows:

Operation Procedure

1. Perform [BRC-34, "Basic Inspection"](#) using information from customer.
2. After ignition switch is turned OFF, connect CONSULT-II to data link connector.

CAUTION:

If CONSULT-II is used with no connection of CONSULT-II CONVERTER, malfunctions might be detected in self-diagnosis depending on control unit which carry out CAN communication.

3. Start engine and drive at approximately 30 km/h (19 MPH) for approximately 1 minute.
4. After stopping vehicle, with engine still idling, touch "START", "ABS", and "SELF-DIAG RESULTS" on CONSULT-II screen in this order.

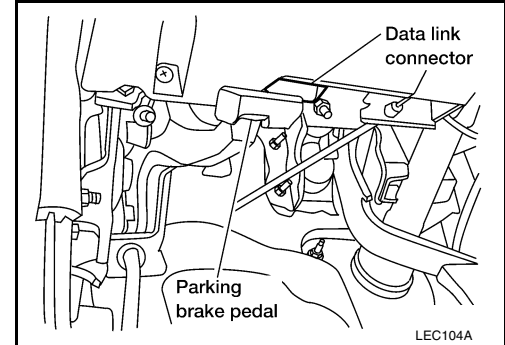
**CAUTION:**

Just after starting engine, or turning ignition switch ON, "ABS" may not be displayed on system selection screen even if "START" is touched. In this case, start self-diagnosis again from step 2. If it cannot be shown after several attempts, ABS actuator and electric unit (control unit) may have malfunctioned. Replace ABS actuator and electric unit (control unit). Refer to [BRC-51, "ABS Actuator and Electric Unit"](#) .

5. Self-diagnosis result is displayed. (If necessary, touch "PRINT" to print self-diagnosis result.)
 - When "NO FAILURE" is shown, check ABS warning lamp. Refer to [BRC-33, "For Fast and Accurate Diagnosis"](#) .
 - CONSULT-II self-diagnosis results are displayed without regard to occurrence timing. In some cases later ones (timing value is small) appear on next screen.
6. Go to appropriate "Inspection" chart according to "Display Item List", and repair or replace as necessary.
7. Start engine and drive at approximately 30 km/h (19 MPH) for approximately 1 minute.

CAUTION:

● **Check again to make sure that there is no malfunction on other parts.**

8. Turn ignition switch OFF to prepare for erasing memory.
9. Start engine and touch "START", "ABS", "SELF-DIAGNOSIS RESULTS", and "ERASE MEMORY" on CONSULT-II screen in this order to erase memory.

CAUTION:

If memory cannot be erased, return to step 6.

10. Drive vehicle at approximately 30 km/h (19 MPH) and check that ABS warning lamp stays off.

TROUBLE DIAGNOSIS

[ABS]

Self-Diagnostic Results Mode

Self-diagnostic item	Malfunction detecting condition	Check system	
FR LH SENSOR- 1 [C1104]	Circuit of front LH wheel sensor is open, shorted or sensor power voltage is unusual	BRC-35, "Inspection 1 Wheel Sensor System" (Note 1)	
RR RH SENSOR- 1 [C1101]	Circuit of rear RH wheel sensor (4WD) or rear sensor (2WD) is open, shorted or sensor voltage is unusual		
FR RH SENSOR- 1 [C1103]	Circuit of front RH wheel sensor is open, shorted or sensor voltage is unusual		
RR LH SENSOR- 1 [C1102]	Circuit of rear LH wheel sensor (4WD) or rear sensor (2WD) is open, shorted or sensor voltage is unusual		
FR LH SENSOR- 2 [C1108]	ABS actuator and electric unit (control unit) cannot identify sensor pulses, because of large gap between wheel sensor and sensor rotor.		
RR RH SENSOR- 2 [C1105]	ABS actuator and electric unit (control unit) cannot identify sensor pulses, because of large gap between wheel sensor and sensor rotor.		
FR RH SENSOR- 2 [C1107]	ABS actuator and electric unit (control unit) cannot identify sensor pulses, because of large gap between wheel sensor and sensor rotor.		
RR LH SENSOR- 2 [C1106]	ABS actuator and electric unit (control unit) cannot identify sensor pulses, because of large gap between wheel sensor and sensor rotor.		
STOP LAMP SW [C1116]	Stop lamp switch circuit is open.		BRC-40, "Inspection 6 Stop Lamp Switch and Circuit"
PRESS SEN CIRCUIT [C1142]	Pressure switch signal line is open or shorted, or pressure switch is malfunctioning (2WD models).		BRC-37, "Inspection 3 Pressure Switch and Circuit Between Pressure Switch and ABS Actuator and Electric Unit (Control Unit)"
FR LH IN ABS SOL [C1120]	Circuit of front LH IN ABS solenoid is open or shorted, or control line is open or shorted to power supply or ground.	BRC-38, "Inspection 4 Solenoid Valve and Circuits"	
FR LH OUT ABS SOL [C1121]	Circuit of front LH OUT ABS solenoid is open or shorted, or control line is open or shorted to power supply or ground.		
RR RH IN ABS SOL [C1126]	Circuit of rear RH IN ABS solenoid is open or shorted, or control line is open or shorted to power supply or ground.		
RR RH OUT ABS SOL [C1127]	Circuit of rear RH OUT ABS solenoid is open or shorted, or control line is open or shorted to power supply or ground.		
FR RH IN ABS SOL [C1122]	Circuit of front RH IN ABS solenoid is open or shorted, or control line is open or shorted to power supply or ground.		
FR RH OUT ABS SOL [C1123]	Circuit of front RH OUT ABS solenoid is open or shorted, or control line is open or shorted to power supply or ground.		
RR LH IN ABS SOL [C1124]	Circuit of rear LH IN ABS solenoid is open or shorted, or control line is open or shorted to power supply or ground.		
RR LH OUT ABS SOL [C1125]	Circuit of rear LH OUT ABS solenoid is open or shorted, or control line is open or shorted to power supply or ground.		
PUMP MOTOR (Note 2) [C1111]	During actuator motor operation with ON, when actuator motor turns OFF or when control line for actuator motor relay is open. During actuator motor operation with OFF, when actuator motor turns ON or when control line for relay is shorted to ground.		BRC-39, "Inspection 5 Actuator Motor, Motor Relay, and Circuit"
ABS SENSOR [ABNORMAL SIGNAL] [C1115]	Wheel sensor input is abnormal.		BRC-35, "Inspection 1 Wheel Sensor System" (Note 1)

A

B

C

D

E

BRC

G

H

I

J

K

L

M

TROUBLE DIAGNOSIS

[ABS]

Self-diagnostic item	Malfunction detecting condition	Check system
BATTERY VOLTAGE [ABNORMAL] [C1109]	ABS actuator and electric unit (control unit) power voltage is too low.	BRC-41, "Inspection 7 ABS Actuator and Electric Unit (Control Unit) Power Supply and Ground Circuit"
CONTROLLER FAILURE [C1110]	Internal malfunction of ABS actuator and electric unit (control unit)	BRC-36, "Inspection 2 ABS Actuator and Electric Unit (Control Unit) System"
DECEL G-SENSOR [C1113] (4WD models)	Decel G-sensor is malfunctioning or signal line of decel G-sensor is open or shorted	BRC-44, "Inspection 9 When "DECEL G-SENSOR" Appears on Self-Diagnosis Results Display (4WD Models)"
ACTUATOR [C1140]	Actuator solenoid valve relay is ON, even if control unit sends off signal	BRC-39, "Inspection 5 Actuator Motor, Motor Relay, and Circuit"
	Actuator solenoid valve relay is OFF, even if control unit sends on signal	

Note 1. If wheel sensor 2 for each wheel is indicated, check ABS actuator and electric unit (control unit) power supply voltage in addition to wheel sensor circuit check.

Note 2: "ACTUATOR RLY" on the CONSULT-II self-diagnosis results indicates the malfunction of the actuator motor relay or circuit.

DATA MONITOR

- For details of data monitor function, refer to “CONSULT-II Instruction Manual”.

Operation Procedure

- Turn ignition switch OFF.
- Connect CONSULT-II to data link connector.

CAUTION:

If CONSULT-II is used with no connection of CONSULT-II CONVERTER, malfunctions might be detected in self-diagnosis depending on control unit which carry out CAN communication.

- Turn ignition switch ON.
- Touch “START” on display.

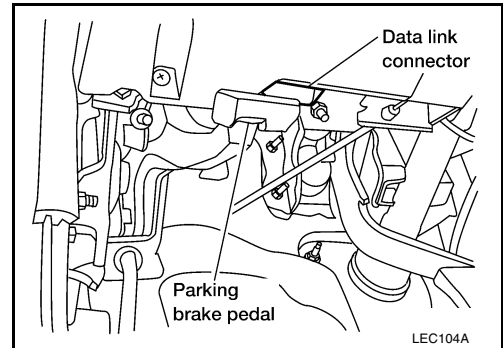

- Touch “ABS” on display.

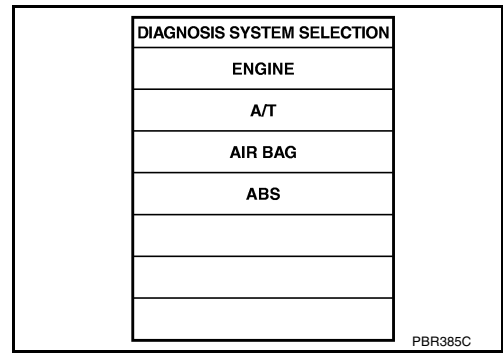

- Touch “DATA MONITOR”.

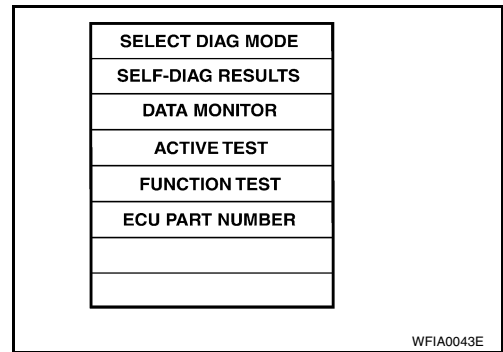

- Return to monitor item selection screen and touch any of “ECU INPUT SIGNALS”, “MAIN SIGNALS”, “CAN DIAG SUPPORT MNTR” or “SELECTION FROM MENU”. Refer to [BRC-30, "Display Item List"](#).

- Touch “START”.
- Screen of data monitor is displayed.

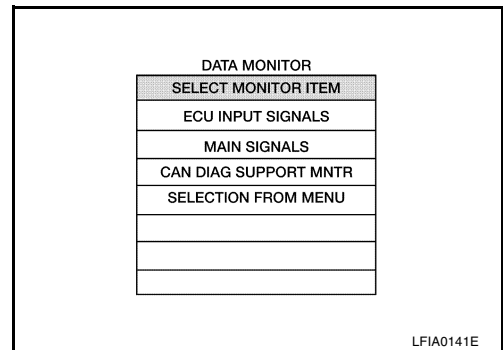

A
B
C
D
E

BRC

G
H
I
J
K
L
M

TROUBLE DIAGNOSIS

[ABS]

Display Item List

Item (Unit)	Data monitor item selection			Remarks
	ECU INPUT SIGNALS	MAIN SIGNALS	SELECTION FROM MENU	
FR RH SENSOR (km/h, MPH)	×	×	×	Wheel speed calculated by front RH wheel sensor signal is displayed.
FR LH SENSOR (km/h, MPH)	×	×	×	Wheel speed calculated by front LH wheel sensor signal is displayed.
RR RH SENSOR (km/h, MPH) (4WD)	×	×	×	Wheel speed calculated by rear RH wheel sensor signal is displayed.
RR LH SENSOR (km/h, MPH) (4WD)	×	×	×	Wheel speed calculated by rear LH sensor signal is displayed.
RR LH SENSOR (km/h, MPH) (2WD)	×	×	×	Wheel speed calculated by rear wheel sensor signal is displayed.
BATTERY VOLT (V)	×	×	×	Voltage supplied to ABS actuator and electric unit (control unit) is displayed.
SLCT LVR POSI	×	×	×	Shift position judged by PNP switch signal.
PRESS SW (ON/OFF) (2WD)	×	-	×	Brake fluid pressure detected by pressure switch is displayed.
STOP LAMP SW (ON/OFF)	×	×	×	Stop lamp switch (ON/OFF) status is displayed.
ABS WARN LAMP (ON/OFF)	-	×	×	ABS warning lamp (ON/OFF) status is displayed.
FR LH IN SOL (ON/OFF)	-	×	×	Front LH IN ABS solenoid (ON/OFF) status is displayed.
FR LH OUT SOL (ON/OFF)	-	×	×	Front LH OUT ABS solenoid (ON/OFF) status is displayed.
RR RH IN SOL (ON/OFF)	-	×	×	Rear RH IN ABS solenoid (ON/OFF) status is displayed.
RR RH OUT SOL (ON/OFF)	-	×	×	Rear RH OUT ABS solenoid (ON/OFF) status is displayed.
FR RH IN SOL (ON/OFF)	-	×	×	Front RH IN ABS solenoid (ON/OFF) status is displayed.
FR RH OUT SOL (ON/OFF)	-	×	×	Front RH OUT ABS solenoid (ON/OFF) status is displayed.
RR LH IN SOL (ON/OFF)	-	×	×	Rear LH IN ABS solenoid (ON/OFF) status is displayed.
RR LH OUT SOL (ON/OFF)	-	×	×	Rear LH OUT ABS solenoid (ON/OFF) status is displayed.
MOTOR RELAY (ON/OFF)	-	×	×	ABS motor relay signal (ON/OFF) status is displayed.
ACTUATOR RLY (ON/OFF)	-	×	×	ABS actuator relay signal (ON/OFF) status is displayed.
ABS FAIL SIG (ON/OFF)	-	-	×	ABS fail signal (ON/OFF) status is displayed.
EBD FAIL SIG (ON/OFF)	-	-	×	EBD fail signal (ON/OFF) status is displayed.
EBD SIGNAL (ON/OFF)	-	-	×	EBD operation (ON/OFF) status is displayed.
ABS SIGNAL (ON/OFF)	-	-	×	ABS operation (ON/OFF) status is displayed.

×:Applicable

For Fast and Accurate Diagnosis

PRECAUTIONS FOR DIAGNOSIS

- Before performing diagnosis, always read precautions. Refer to [BRC-4, "PRECAUTIONS"](#) .
- When replacing ABS actuator and electric unit (control unit), be sure labels on control units are the same color.
- After diagnosis is finished, be sure to erase memory. Refer to [BRC-26, "Operation Procedure"](#) .
- When checking continuity and voltage between units, be sure to check for disconnection, looseness, bend, or collapse of connector terminals. If any non-standard condition is found, repair or replace connector terminals.
- For intermittent symptoms, possible cause is malfunction in harness, harness connector, or terminals. Move harness, harness connector, and terminals to check for poor connections.
- If a circuit tester is used for the check, be careful not to forcibly extend any connector terminal.
- To use CONSULT-II to perform self-diagnosis of ABS actuator and electric unit (control unit), active tests, or work support, first stop work, then connect CONSULT-II and select "ABS".
- CONSULT-II self-diagnosis results are displayed without regard to occurrence timing. In some cases later ones (timing value is small) appear on the next screen.
- While self-diagnosis results of CONSULT-II shows an error, if CONSULT-II active test is performed, an engine system error may be indicated. In this case, start engine to resume the normal screen.
- The following symptoms may be caused by normal operations:

Symptom	Symptom description	Result
Motor operation noise	This is noise of motor inside ABS actuator. Slight noise may occur during ABS operation.	Normal
	When the vehicle speed goes over 20 km/h (12.5 mph), the motor and valves operating noise may be heard. It happens only once after IGN (ignition) is ON. This is a normal status of the system operation check.	
System operation check noise	When the engine starts, slight "click" noise may be heard from engine compartment. This is normal and is part of system operation check.	Normal
ABS operation (Longer stopping distance)	On roads with low friction coefficients, such as snowy roads or gravel roads, vehicles with ABS may require a longer stopping distance. Therefore, when driving on such roads, avoid overconfidence and keep speed sufficiently low.	Normal

ON and OFF Timing for ABS Warning Lamp

×: ON -: OFF

Condition	ABS warning lamp	Remarks
Ignition SW OFF	-	-
For approx. 2 seconds after ignition SW is turned ON	×	-
Approx. 2 seconds after ignition switch ON	-	Turns OFF 2 seconds after ignition switch ON.
There is an ABS error.	×	-
	×	There is an ABS actuator and electric unit (control unit) error. (Power or ground malfunction)

Basic Inspection

BASIC INSPECTION 1: BRAKE FLUID LEVEL AND LEAK INSPECTION

1. Check fluid level in the brake reservoir tank. If fluid level is low, refill the brake fluid.
2. Check for leakage in brake piping and around ABS actuator. If leakage or seepage is found, check as follows.
 - If ABS actuator and electric unit (control unit) connector is loose, tighten piping to specified torque. Then inspect again and confirm that there is no leakage.
 - If connection of flare nuts or screws of ABS actuator are damaged, replace damaged parts. Then inspect again and confirm that there is no leakage.
 - If there is leakage or seepage at any location other than ABS actuator connections, wipe away leakage or seepage with clean cloth. Then inspect again and confirm that there is no leakage.
 - If there is leakage from ABS actuator, wipe away leakage or seepage with clean cloth. Then inspect again. If there is leakage or seepage, replace ABS actuator unit.

CAUTION:

ABS actuator body cannot be disassembled.

3. Check brake disc rotor and pads and brake drum and linings. Refer to [MA-42, "Checking Disc Brake"](#) and [MA-42, "Checking Drum Brake"](#).

BASIC INSPECTION 2: INSPECTION FOR LOOSENESS OF POWER SYSTEM TERMINALS

Check battery for looseness on the battery positive/negative terminals and ground connection. If looseness is detected, tighten the cables to the specified torque. Check that the battery voltage does not drop and the generator is normal.

BASIC INSPECTION 3: INSPECTION OF ABS WARNING LAMP

1. Check that ABS warning lamp illuminates for approximately 2 seconds when ignition switch is turned ON. If it does not illuminate, inspect ABS warning lamp and circuit, and inspect combination meter. Refer to [BRC-13, "Schematic"](#).

Symptom Chart

Symptom	Malfunctioning part	Reference page
ABS works frequently	—	BRC-44
Unexpected pedal reaction	—	BRC-44
Long stopping distance	—	BRC-45
ABS does not work	—	BRC-46
Pedal vibration and noise	—	BRC-46
ABS warning lamp does not illuminate	<ul style="list-style-type: none"> ● Fuse ● Combination meter ● Circuit(s) ● ABS actuator and electric unit (control unit) 	BRC-42

Inspection 1 Wheel Sensor System**INSPECTION PROCEDURE****DTC C1101, C1102, C1103, C1104, C1105, C1106, C1107, C1108 or C1115**

First use CONSULT-II self-diagnosis results to determine positions of malfunctioning wheel sensors. Then inspect parts and determine which parts to replace.

1. CONNECTOR INSPECTION

1. Disconnect the ABS actuator and electric unit (control unit) connector E39 and wheel sensor of malfunction code. Check the terminals for deformation, disconnection, looseness or damage.

OK or NG

OK >> GO TO 2.

NG >> Repair or replace as necessary.

2. CHECK WHEEL SENSOR OUTPUT SIGNAL

1. Disconnect connector from wheel sensor of malfunction code No.
2. Connect ABS active wheel sensor tester (J-45741) to wheel sensor using appropriate adapter.
3. Turn on the ABS active wheel sensor tester power switch.

NOTE:

The green POWER indicator should illuminate. If the POWER indicator does not illuminate, replace the battery in the ABS active wheel sensor tester before proceeding.

4. Spin the wheel of the vehicle by hand and observe the red SENSOR indicator on the ABS active wheel sensor tester. The red SENSOR indicator should flash on and off to indicate an output signal.

NOTE:

If the red SENSOR indicator illuminates but does not flash, reverse the polarity of the tester leads and retest.

Does the ABS active wheel sensor tester detect a signal?

Yes >> GO TO 3.

No >> GO TO 6.

3. CHECK TIRE

Check for inflation pressure, wear and size of each tire.

Are tire pressure and size correct and is tire wear within specifications?

Yes >> GO TO 4.

No >> Adjust tire pressure or replace tire(s).

4. CHECK WHEEL BEARINGS

Check wheel bearing axial end play. Refer to [FAX-5, "Front Wheel Bearing"](#) or [RAX-6, "Rear Wheel Bearing"](#).

Is axial end play within specifications?

Yes >> GO TO 5.

No >> Repair as necessary. Refer to [FAX-9, "WHEEL HUB AND KNUCKLE"](#) or [RAX-7, "WHEEL HUB"](#). Then retest.

5. SENSOR ROTOR INSPECTION

Check for damage to sensor rotor teeth.

Is inspection result OK?

OK >> GO TO 6.

NG >> Replace sensor rotor. Refer to [BRC-49, "Front Sensor Rotor"](#) or [BRC-49, "Rear Sensor Rotor \(4WD\)"](#).

6. CHECK WIRING HARNESS FOR SHORT CIRCUIT

1. Disconnect ABS actuator and electric unit (control unit) connector and wheel sensor connector of malfunction code No.
2. Check resistance between harness connector terminal and ground.

Continuity should not exist.

OK or NG?

- OK >> GO TO 7.
 NG >> Repair the circuit.

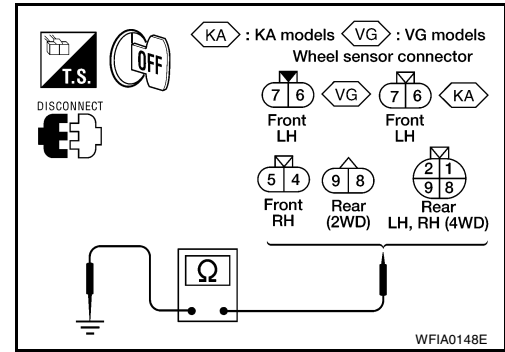

7. CHECK WIRING HARNESS FOR OPEN CIRCUIT

1. Disconnect ABS actuator and electric unit (control unit) connector and wheel sensor connector of malfunction code No.
2. Check continuity between both wiring harness ends.

Sensor	ABS actuator and electric unit (control unit)		Wheel sensor		Continuity
	Connector - terminal	Wire color	Connector - terminal	Wire color	
Front LH	E39 - 46	G	E16 - 6	G	Yes
	E39 - 45	R	E16 - 7	R	
Front RH	E39 - 34	P	E2 - 5	P	
	E39 - 33	L	E2 - 4	L	
Rear (2WD)	E39 - 36	W	C6 - 9	W	
	E39 - 37	B	C6 - 8	B	
Rear LH (4WD)	E39 - 36	W	C6 - 9	W	
	E39 - 37	B	C6 - 8	B	
Rear RH (4WD)	E39 - 42	LG	C6 - 1	LG	
	E39 - 43	PU	C6 - 2	PU	

Continuity should exist.

OK or NG?

- OK >> Replace the ABS actuator and electric unit (control unit). Refer to [BRC-51, "ABS Actuator and Electric Unit"](#) .
 NG >> Repair the circuit.

Inspection 2 ABS Actuator and Electric Unit (Control Unit) System

EFS003H0

DTC C1110

Inspection Procedure

1. CHECKING SELF-DIAGNOSIS RESULTS

Check self-diagnosis results.

Self-diagnosis results
CONSULT-II display items
CONTROLLER FAILURE

Does anything other than "CONTROLLER FAILURE" appear on self-diagnosis display?

- YES >> Repair or replace the items indicated. Then perform self-diagnosis again.
 NO >> Replace ABS actuator and electric unit (control unit). Then perform ABS actuator and electric unit (control unit) self-diagnosis again.

Inspection 3 Pressure Switch and Circuit Between Pressure Switch and ABS Actuator and Electric Unit (Control Unit)

NOTE:

Pressure switch applies to 2WD models only.

DTC C1142

Inspection Procedure

1. CHECKING SELF-DIAGNOSIS RESULTS (1)

Check self-diagnosis results.

Self-diagnosis results
CONSULT-II display items
PRESS SEN CIRCUIT

Does "PRESS SEN CIRCUIT" appear on self-diagnosis display?

YES >> GO TO 2.

NO >> Inspection is completed.

2. CHECKING SELF-DIAGNOSIS RESULTS (2)

1. Disconnect pressure switch connector E91 and ABS actuator and electric unit (control unit) connector E39. Then reconnect them securely.
2. Perform ABS actuator and electric unit (control unit) self-diagnosis again.

Is inspection result OK?

OK >> Poor connection of connectors. Repair or replace suspect connector. Perform self-diagnosis again.

NG >> GO TO 3.

3. CHECKING PRESSURE SWITCH CIRCUIT

1. Disconnect pressure switch connector E91 and ABS actuator and electric unit (control unit) connector E39.
2. Check continuity between ABS actuator and electric unit (control unit) harness connector E39 and pressure switch harness connector E91.

ABS actuator and electric unit (control unit) (Harness connector E39)	Pressure switch (Harness connector E91)	Continuity
3 (R/W)	2 (R/W)	Yes

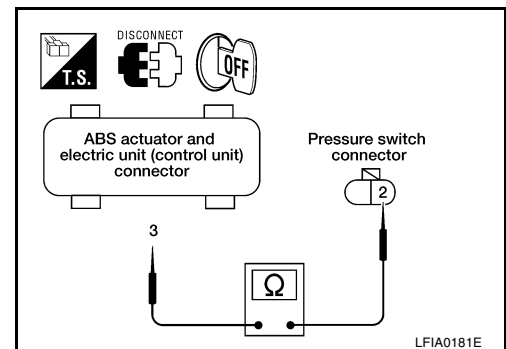

Is inspection result OK?

OK >> GO TO 4.

NG >> Open or short in harness. Repair or replace the suspect harness.

4. CHECKING PRESSURE SWITCH

Check pressure switch value on "DATA MONITOR".

Condition	Data monitor display
Brake pedal depressed	ON
When brake pedal is released.	OFF

Is inspection result OK?

OK >> Inspection is completed.

NG >> Pressure switch malfunction. Replace pressure switch. Refer to [BR-14, "MASTER CYLINDER"](#).

A

B

C

D

E

BRC

G

H

I

J

K

L

M

Inspection 4 Solenoid Valve and Circuits

DTC C1120, C1121, C1122, C1123, C1124, C1125, C1126 or C1127

Inspection Procedure

1. CHECKING SELF-DIAGNOSIS RESULTS (1)

Check self-diagnosis results.

Self-diagnosis results
CONSULT-II display items
FR LH IN ABS SOL
FR LH OUT ABS SOL
RR RH IN ABS SOL
RR RH OUT ABS SOL
FR RH IN ABS SOL
FR RH OUT ABS SOL
RR LH IN ABS SOL
RR LH OUT ABS SOL

Do above items appear on self-diagnosis results display?

YES >> GO TO 2.

NO >> Inspection is completed.

2. CHECKING SELF-DIAGNOSIS RESULTS (2)

1. Disconnect ABS actuator and electric unit (control unit) connector E39. Then reconnect it securely.
2. Perform self-diagnosis again.

Do any self-diagnosis items appear?

YES >> GO TO 3.

NO >> Poor connection. Repair or replace the connector.

3. CHECKING SOLENOID POWER AND GROUND

1. Disconnect ABS actuator and electric unit (control unit) connector E39.
2. Check voltage between ABS actuator and electric unit (control unit) harness connector E39 and ground.

ABS actuator and electric unit (control unit) (Harness connector E39)	Body ground	Voltage (V) (Approx.)
32 (Y)	—	12

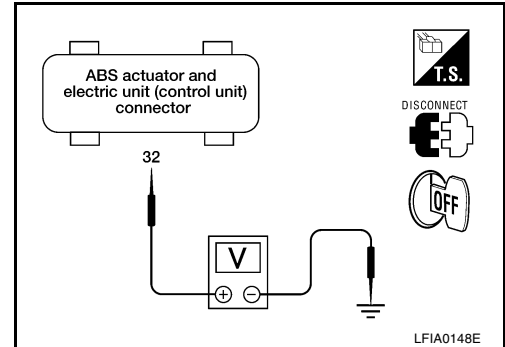

3. Check resistance between ABS actuator and electric unit (control unit) harness connector E39 and body ground.

ABS actuator and electric unit (control unit) (Harness connector E39)	Body ground	Resistance value (Ω) (Approx.)
16 (B)	—	0
47 (B)	—	0

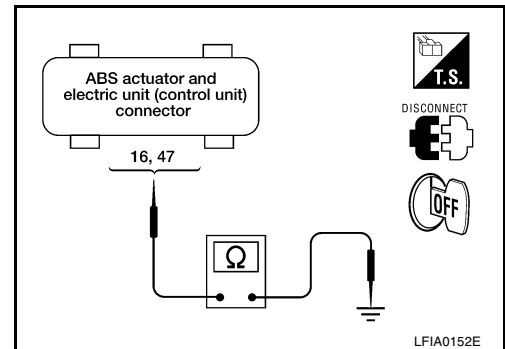

Is inspection result OK?

- OK >> Replace ABS actuator and electric unit (control unit).
- NG >> Repair harness or connectors.

Inspection 5 Actuator Motor, Motor Relay, and Circuit

EFS003H3

DTC C1111

Inspection Procedure

1. CHECKING SELF-DIAGNOSIS RESULTS (1)

Check self-diagnosis results.

Self-diagnosis results
CONSULT-II display items
PUMP MOTOR

Does “PUMP MOTOR” appear in self-diagnosis results display?

- YES >> GO TO 2.
- NO >> Inspection is completed.

2. CHECKING SELF-DIAGNOSIS RESULTS (2)

1. Disconnect ABS actuator and electric unit (control unit) connector E39. Then reconnect it securely.
2. Perform self-diagnosis again.

Do any self-diagnosis items appear?

- YES >> GO TO 3.
- NO >> Poor connection. Repair or replace the applicable connector.

3. CHECKING ABS MOTOR AND MOTOR RELAY POWER SYSTEM

1. Disconnect ABS actuator and electric unit (control unit) connector.
2. Check voltage between ABS actuator and electric unit (control unit) connector E39 and body ground.

ABS actuator and electric unit (control unit) (Harness connector E39)	Body ground	Voltage (V) (Approx.)
1 (L)	—	12

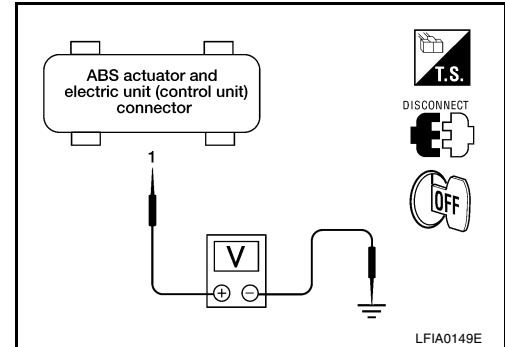

3. Check resistance between ABS actuator and electric unit (control unit) connector E39 and ground.

ABS actuator and electric unit (control unit) (Harness connector E39)	Body ground	Resistance value (Ω) (Approx.)
16 (B)	—	0

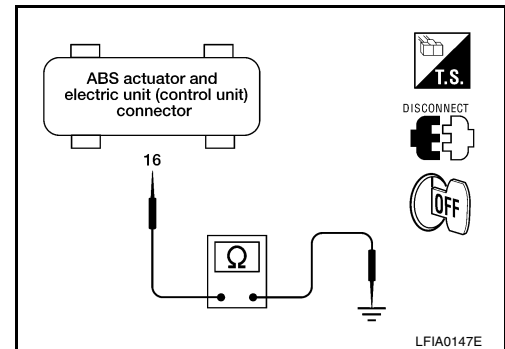

Is inspection result OK?

- YES >> Replace ABS actuator and electric unit (control unit).
 Refer to [BRC-51, "ABS Actuator and Electric Unit"](#).
- NO >> Repair harness or connectors.

Inspection 6 Stop Lamp Switch and Circuit

EFS003H4

DTC C1116

Inspection Procedure

1. CHECKING SELF-DIAGNOSIS RESULTS

Check self-diagnosis results.

Self-diagnosis results
CONSULT-II display items
STOP LAMP SW

Does "STOP LAMP SW" appear in self-diagnosis results display?

- YES >> GO TO 2.
 NO >> Inspection is completed.

2. CHECKING STOP LAMP

1. Disconnect stop lamp switch connector and ABS actuator and electric unit (control unit) connector.
2. Reconnect connectors securely.
3. Start engine.
4. Repeat pumping brake pedal carefully several times, then perform self-diagnosis again.

Do any self-diagnosis items appear?

- YES >> GO TO 3.
 NO >> Poor connection. Repair or replace the applicable connector.

3. CHECKING STOP LAMP SWITCH CIRCUIT

1. Disconnect stop lamp switch connector and ABS actuator and electric unit (control unit) connector.
2. Check continuity between stop lamp switch harness connector M47 and ABS actuator and electric unit (control unit) harness connector E39.

ABS actuator and electric unit (control unit) (Harness connector E39)	Stop lamp switch (Harness connector M47)	Continuity
41 (BR/R)	2 (BR/R)	Yes

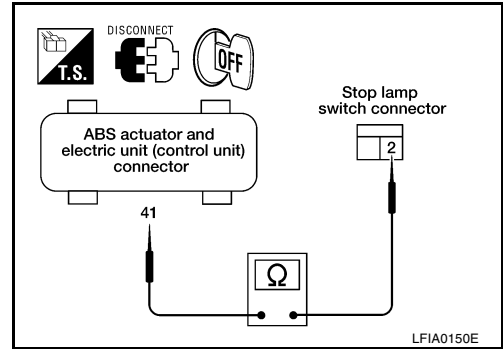

Is inspection result OK?

- OK >> Perform ABS actuator and electric unit (control unit) self-diagnosis again.
- NG >> Open or short in harness between ABS actuator and electric unit (control unit) and stop lamp switch.

Inspection 7 ABS Actuator and Electric Unit (Control Unit) Power Supply and Ground Circuit

EFS003H5

DTC C1109

Inspection Procedure

1. CHECKING SELF-DIAGNOSIS RESULT

Check self-diagnosis results.

Self-diagnosis results
CONSULT-II display items
BATTERY VOLTAGE

Does "BATTERY VOLTAGE" appear in self-diagnosis results display?

- YES >> GO TO 2.
- NO >> Inspection is completed.

2. STARTING INSPECTION

1. Disconnect ABS actuator and electric unit (control unit) connector E39. Then reconnect it securely.
2. Perform self-diagnosis.

Do any self-diagnosis items appear?

- YES >> GO TO 3.
- NO >> Poor connection. Repair or replace the connector.

3. CHECKING ABS ACTUATOR AND ELECTRIC UNIT (CONTROL UNIT) POWER SUPPLY

1. Disconnect ABS actuator and electric unit (control unit) connector E39.
2. Turn ignition switch ON (but do not start engine). Check voltage between ABS actuator and electric unit (control unit) harness connector E39 and body ground.

ABS actuator and electric unit (control unit) (Harness connector E39)	Body ground	Voltage (V) (Approx.)
4 (B/P)	—	12

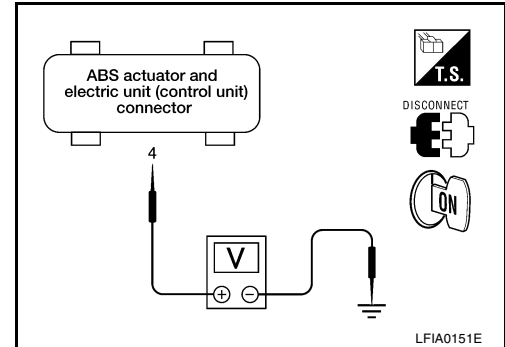

3. Check voltage between ABS actuator and electric unit (control unit) harness connector E39 and body ground.

ABS actuator and electric unit (control unit) (Harness connector E39)	Body ground	Voltage (V) (Approx.)
32 (Y)	—	12

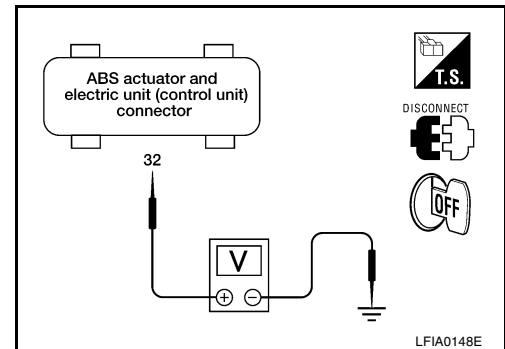

Is inspection result OK?

- OK >> GO TO 4.
- NG >> Repair power supply.

4. CHECKING ABS ACTUATOR AND ELECTRIC UNIT (CONTROL UNIT) GROUND CIRCUITS

Check ABS actuator and electric unit (control unit) ground circuits.

ABS actuator and electric unit (control unit) (Harness connector E39)	Body ground	Continuity
16 (B)	—	Yes
47 (B)	—	Yes

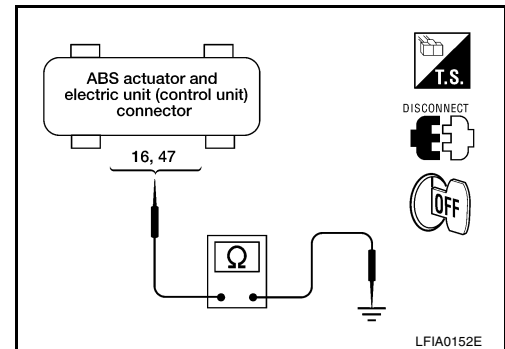

Is inspection result OK?

- OK >> Perform ABS actuator and electric unit (control unit) self-diagnosis again.
- NG >> Repair harness or connectors.

Inspection 8 ABS Warning Lamp Does Not Come On When Ignition Switch Is Turned On

EFS003H6

1. INSPECTION START

Warning lamp circuit inspection.

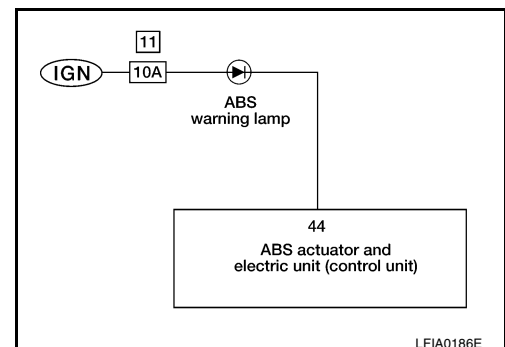

>> GO TO 2.

2. CHECK FUSE

Check 10A fuse [No. 11 located in the fuse block (J/B)]. For fuse layout, refer to [PG-9, "POWER SUPPLY ROUTING"](#).

OK or NG?

- OK >> GO TO 3.
- NG >> Replace fuse.

3. CHECK POWER SUPPLY CIRCUIT

1. Install 10A fuse [No. 11 located in the fuse block (J/B)].
2. Disconnect ABS actuator and electric unit (control unit) connector.
3. Turn ignition switch ON.
4. Check voltage between ABS actuator and electric unit (control unit) connector E39 terminal 44 (L/W) and ground.

Battery voltage should exist.

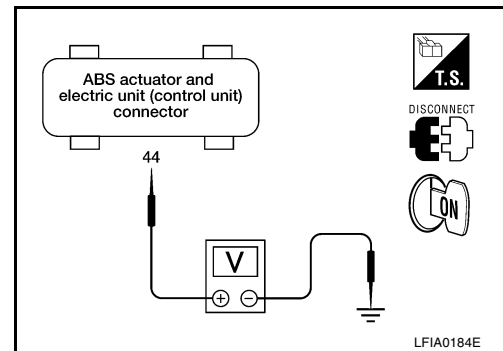

OK or NG?

- OK >> GO TO 5.
- NG >> GO TO 4.

4. CHECK INDICATOR BULB

Check indicator lamp bulb.

OK or NG?

- OK >> Repair harness or connectors between fuse and ABS actuator and electric unit (control unit) terminal 44 (including combination meter).
- NG >> Replace combination meter.

5. CHECK CIRCUIT

1. Turn ignition switch OFF.
2. Disconnect ABS actuator and electric unit (control unit) and combination meter connectors.
3. Check continuity between ABS actuator and electric unit (control unit) connector E39 terminal 44 (L/W) and combination meter connector M38 terminal 24 (L/W).

Continuity should exist.

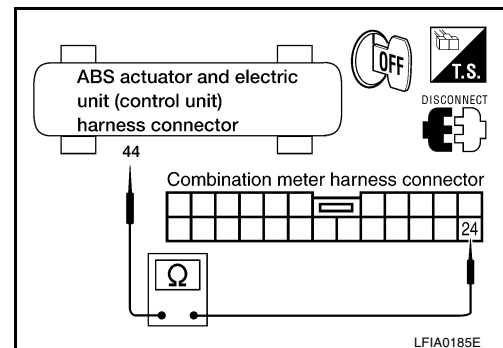

OK or NG?

- OK >> Reconnect connectors and perform self-diagnosis. Repair or replace.
- NG >>
 - Check harness connectors E39, M38
 - Harness for open or short between ABS actuator and electric unit (control unit) and combination meter

Inspection 9 When "DECEL G-SENSOR" Appears on Self-Diagnosis Results Display (4WD Models)

EFS003H7

DTC C1113

Inspection Procedure

1. CHECKING SELF-DIAGNOSIS RESULTS

Check self-diagnosis results.

Self-diagnosis results
CONSULT-II display items
DECEL G-SENSOR

Does anything besides "DECEL G-SENSOR" appear on self-diagnosis results display?

- YES >> Inspect and repair the indicated items. Then perform self-diagnosis again to confirm repair.
- NO >> Replace ABS actuator and electric unit (control unit). Refer to [BRC-51, "ABS Actuator and Electric Unit"](#) . Then perform self-diagnosis again to confirm repair.

Symptom 1 ABS Works Frequently

EFS003H8

Inspection Procedure

1. STARTING INSPECTION

Inspect wheel sensor system.

- Sensor mounting inspection
- Sensor pick-up inspection for iron chips
- Sensor rotor inspection (e.g. Number of teeth, damaged teeth)
- Sensor connector engagement inspection

Is inspection result OK?

- OK >> GO TO 2.
- NG >> Repair wheel sensor and rotor system.

2. CHECKING FOR LOOSENESS

Check for looseness of front axle.

Is inspection result OK?

- OK >> GO TO [BRC-44, "Symptom 2 Unexpected Pedal Reaction"](#) .
- NG >> Axle inspection and repair.

Symptom 2 Unexpected Pedal Reaction

EFS003H9

Inspection Procedure

1. BRAKE PEDAL STROKE INSPECTION

Check brake pedal stroke.

Is stroke excessively long?

- YES >> Check bleeding and brake system.
- NO >> GO TO 2.

2. CHECKING PEDAL FORCE

Check that brake is effective with pedal depressed.

Is pedal heavy, but effective?

- YES >> Normal.
NO >> GO TO 3.

3. CONNECTOR AND PERFORMANCE INSPECTION

Disconnect ABS actuator and electric unit (control unit) connector to deactivate ABS function. Check that brake is effective.

Is brake effective?

- YES >> GO TO 4.
NO >> Brake line inspection.

4. CHECKING ABS WARNING LAMP INDICATION

Check that ABS warning lamp illuminates.

Is inspection result OK?

- OK >> Perform self-diagnosis.
NG >> GO TO 5.

5. CHECKING WHEEL SENSORS

Inspect wheel sensor system.

- Sensor mounting inspection
- Check sensor pick-up for adhering iron chips.
- Sensor rotor inspection (e.g. Number of teeth, damaged teeth)
- Sensor connector engagement inspection

Is inspection result OK?

- OK >> Normal.
NG >> Repair wheel sensor and rotor system.

Symptom 3 Long Stopping Distance

EFS003HA

Inspection Procedure

1. STARTING INSPECTION

Check that stopping distance increases only on snowy roads and gravel roads.

Is inspection result OK?

- OK >> May be longer than for vehicles without ABS.
NG >> GO TO 2.

2. CHECKING PERFORMANCE

Disconnect ABS actuator and electric unit (control unit) to deactivate ABS function.

Is stopping distance still long?

- YES >> Inspect brake lines for leaks or damage. Repair as necessary. Bleed brakes. Refer to [BR-10](#), "[Bleeding Brake System](#)".
NO >> GO TO 3.

3. CHECKING ABS WARNING LAMP INDICATION

Check that ABS warning lamp illuminates.

Is inspection result OK?

- OK >> Perform self-diagnosis.
NG >> GO TO 4.

4. CHECKING WHEEL SENSORS

Inspect wheel sensor system.

- Sensor mounting inspection
- Check sensor pick-up for adhering iron chips.
- Sensor rotor inspection (e.g. Number of teeth, damaged teeth)
- Sensor connector engagement inspection

Is inspection result OK?

- OK >> Normal.
 NG >> Repair wheel sensor and rotor system.

Symptom 4 ABS Does Not Work

EFS003HB

Inspection Procedure

1. CHECKING ABS WARNING LAMP INDICATION

Check that ABS warning lamp illuminates.

Is inspection result OK?

- OK >> Perform self-diagnosis.
 NG >> GO TO 2.

2. CHECKING WHEEL SENSORS

Inspect wheel sensor system.

- Sensor mounting inspection
- Check sensor pick-up for adhering iron chips.
- Sensor rotor inspection (e.g. Number of teeth, damaged teeth)
- Sensor connector engagement inspection

Is inspection result OK?

- OK >> Normal.
 NG >> Repair wheel sensor and rotor system.

Symptom 5 Pedal Vibration and Noise

EFS003HC

Inspection Procedure

1. INSPECTION (1)

Check brake system for pedal vibration or noise at engine start.

Is inspection result OK?

- OK >> Perform self-diagnosis.
 NG >> GO TO 2.

2. INSPECTION (2)

Check for vibration during soft braking (just placing foot on pedal).

CAUTION:

ABS may activate in conditions such as those listed below, when wheel speed changes.

- **Gear shifting**
- **Turning at high speed**
- **Passing through gusts of wind**

Is inspection result OK?

- OK >> GO TO 3.
 NG >> Normal.

3. INSPECTION (3)

Does vibration occur during normal braking?

CAUTION:

In addition to activation for sudden braking, ABS may activate in conditions such as those listed below.

- Roads with low friction coefficients
- Turning at high speed
- Passing through gusts of wind

Is inspection result OK?

OK >> GO TO 4.

NG >> Normal.

4. INSPECTION (4)

Check for vibration when engine speed is increased while vehicle is stopped.

Is inspection result OK?

OK >> GO TO 5.

NG >> ● Normal.

CAUTION:

Vibration may occur when vehicle is stopped.

5. INSPECTION (5)

Check for vibration when switches of electrical components are operated.

Is inspection result OK?

OK >> Check for any wireless devices, antennas, or antenna lead near ABS actuator and electric unit (control unit) (including wiring).

NG >> GO TO 6.

6. CHECKING ABS WARNING LAMP INDICATION

Confirm ABS warning lamp turns on.

Is inspection result OK?

OK >> Perform self-diagnosis.

NG >> GO TO 7.

7. CHECKING WHEEL SENSORS

Inspect wheel sensor system.

- Sensor mounting inspection
- Sensor pick-up inspection for iron chips (e.g. Number of teeth, damaged teeth)
- Sensor connector engagement inspection
- Inspection of wheel sensor circuit

Is inspection result OK?

OK >> Normal.

NG >> Repair wheel sensor and rotor system.

A

B

C

D

E

BRC

G

H

I

J

K

L

M

REMOVAL AND INSTALLATION

Front Wheel Sensor

CAUTION:

Be careful not to damage sensor edge and sensor rotor teeth. When removing the front or rear wheel hub assembly, disconnect the ABS wheel sensor from the assembly and move it away.

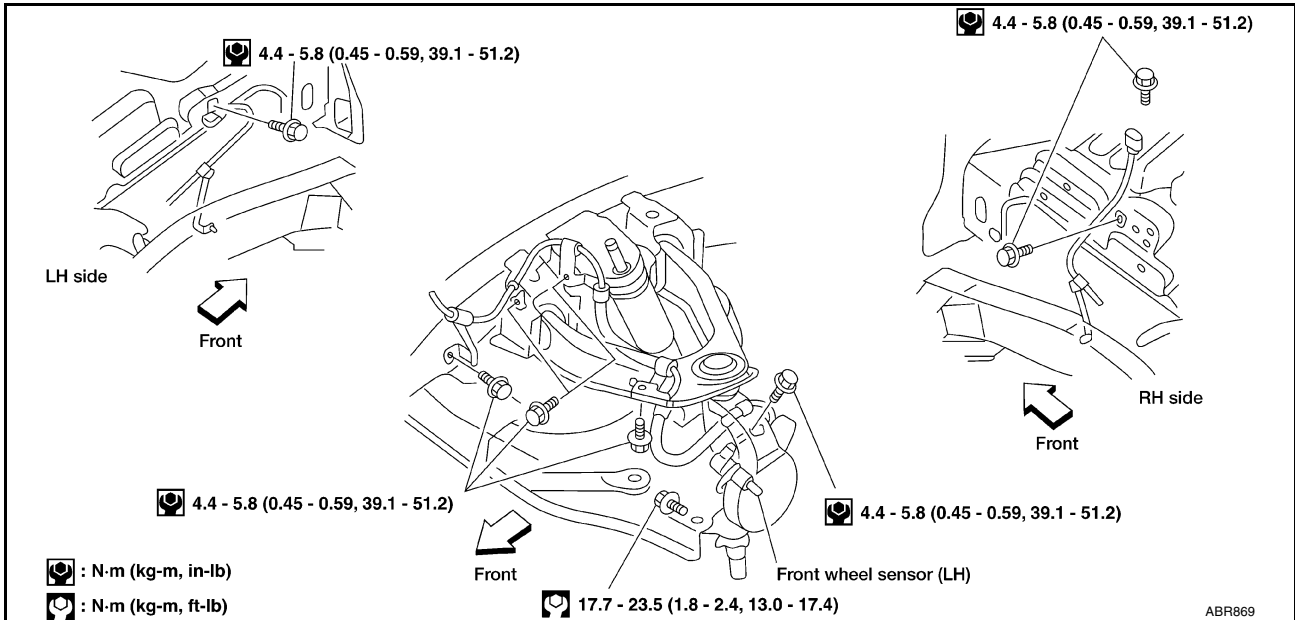

Rear Wheel Sensor 4WD MODELS

CAUTION:

Be careful not to damage sensor edge and sensor rotor teeth. When removing the front or rear wheel hub assembly, disconnect the ABS wheel sensor from the assembly and move it away.

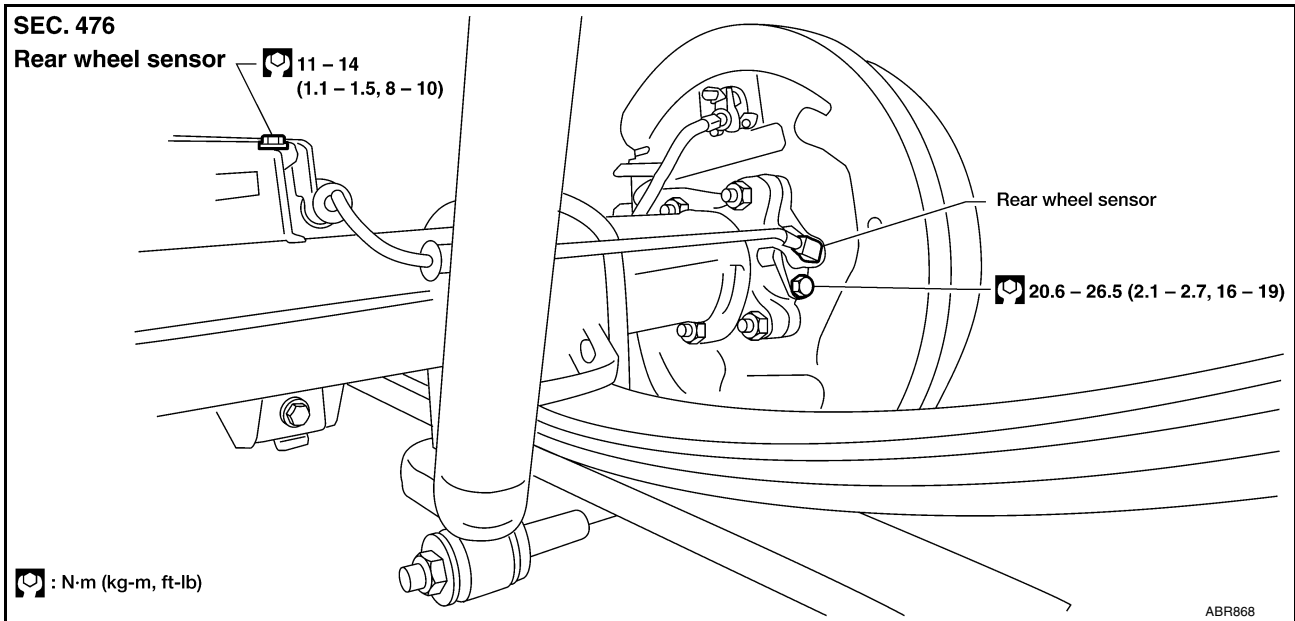

2WD MODELS

CAUTION:

Be careful not to damage sensor edge and sensor rotor teeth. In case the final drive assembly needs to be removed, disconnect the ABS sensor from the final drive assembly and move it away. Failure to do so may result in damage to the sensor wires making the sensor inoperative. For final drive models

REMOVAL AND INSTALLATION

[ABS]

using collapsible spacer (C200), bearing preload must be adjusted whenever companion flange is removed. Therefore, final drive overhaul is required. Refer to [RFD-11, "Components"](#).

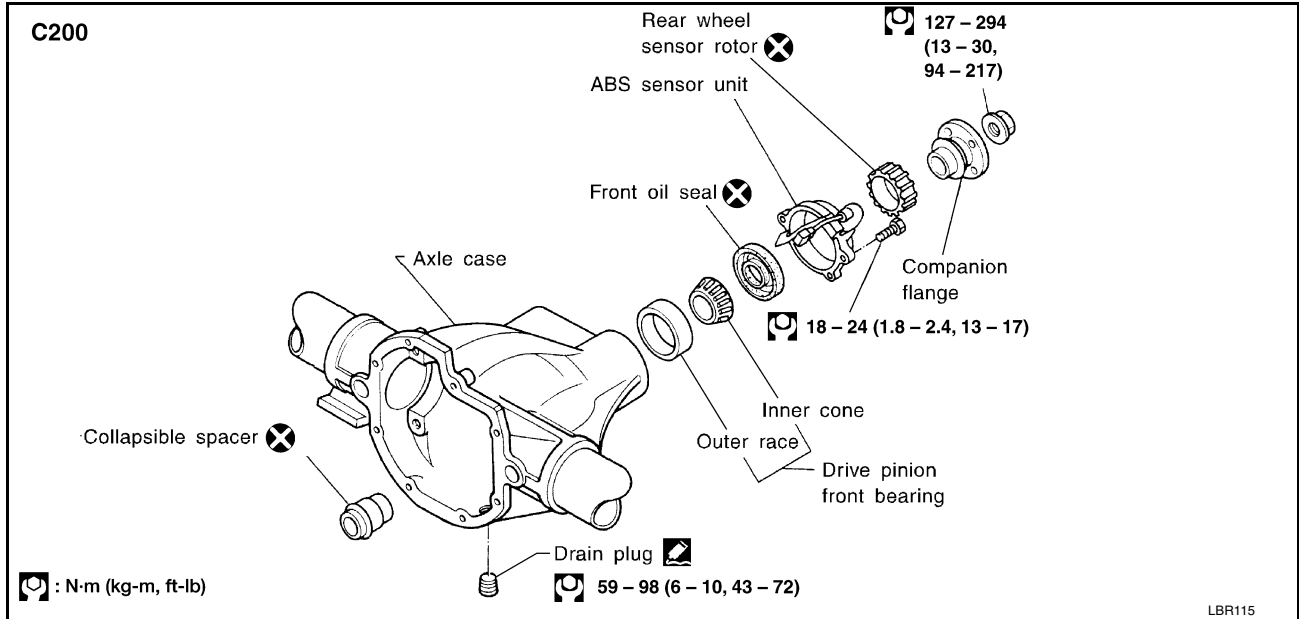

Front Sensor Rotor REMOVAL

EFS003HF

CAUTION:

Be careful not to damage sensor edge and sensor rotor teeth. When removing the front or rear wheel hub assembly, disconnect the ABS wheel sensor from the assembly and move it away.

1. Remove the front wheel hub. Refer to [FAX-14, "WHEEL HUB AND ROTOR DISC"](#).
2. Remove the sensor rotor using suitable puller, drift and bearing replacer.

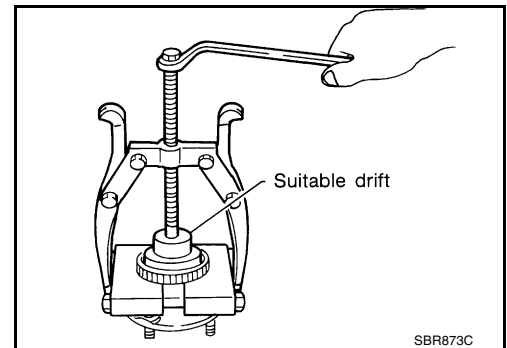

INSTALLATION

Install the sensor rotor using suitable drift and press.

- Always replace sensor rotor with new one.
- Pay attention to the direction of front sensor rotor as shown in figure.

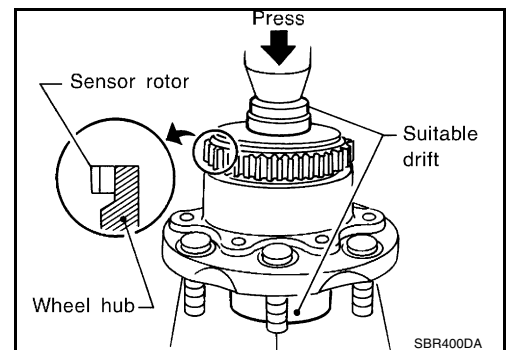

Rear Sensor Rotor (4WD) REMOVAL

EFS003HG

CAUTION:

Be careful not to damage sensor edge and sensor rotor teeth. When removing the front or rear wheel hub assembly, disconnect the ABS wheel sensor from the assembly and move it away.

REMOVAL AND INSTALLATION

[ABS]

- Remove the sensor rotor using Tool.

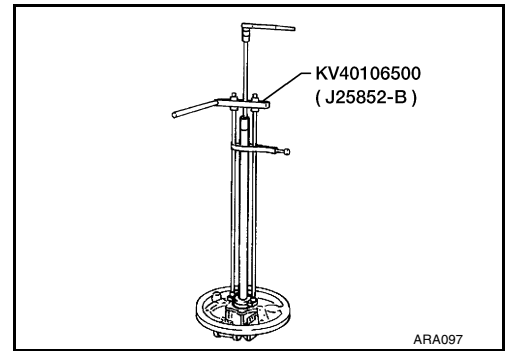

INSTALLATION

Install the sensor rotor using suitable drift and press.

- Always replace sensor rotor with a new one.
- Pay attention to the direction of front sensor rotor as shown in figure.

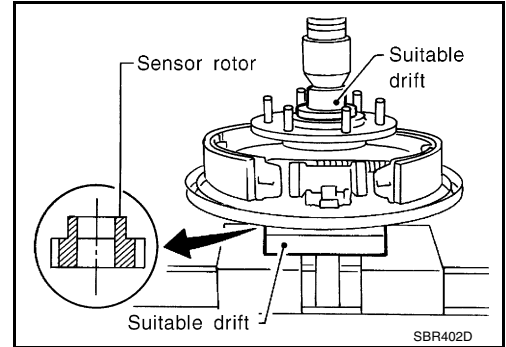

ABS Actuator and Electric Unit REMOVAL

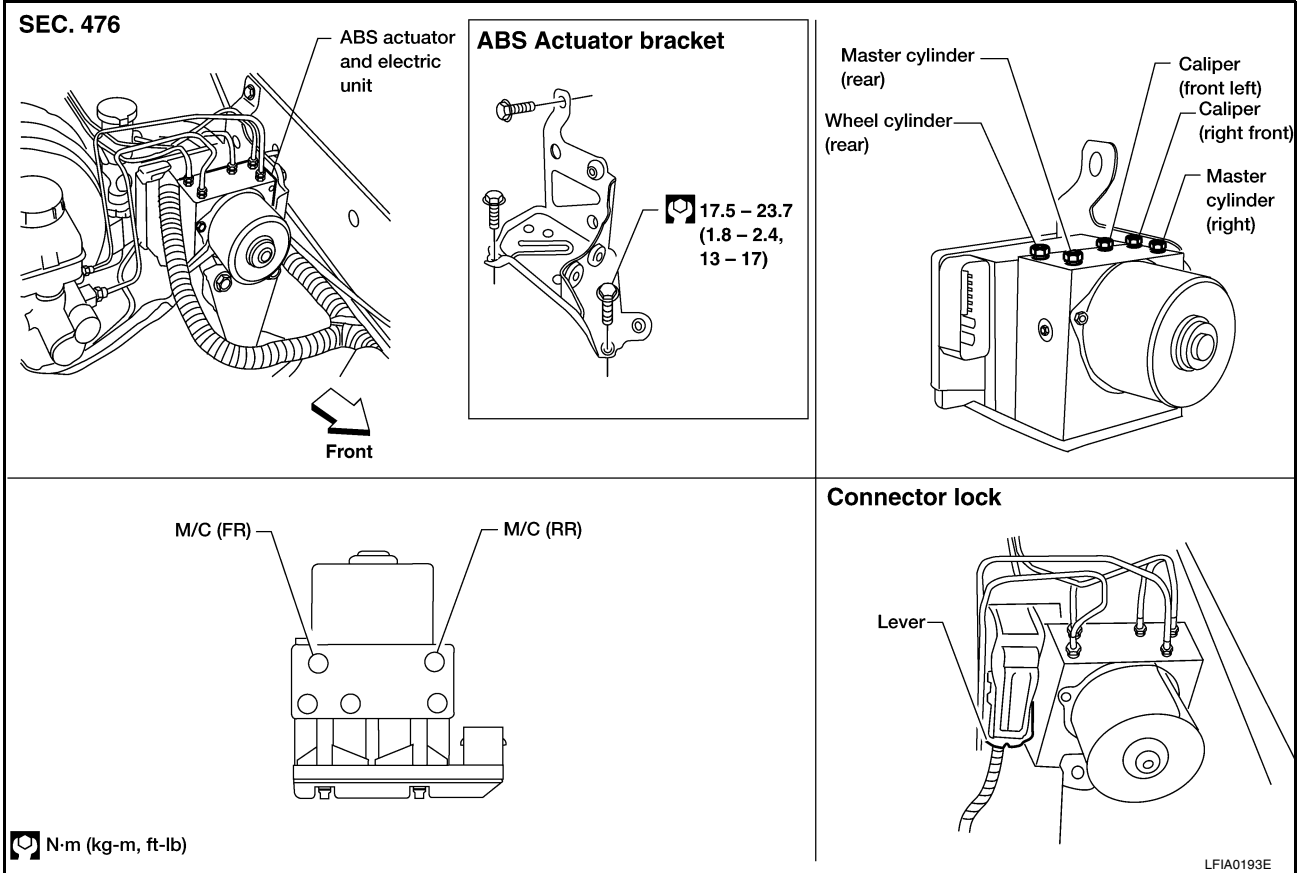

1. Disconnect battery cable.
2. Disconnect connector and brake pipes.
3. Remove fixing bolts.

INSTALLATION

CAUTION:

After installation, refill brake fluid. Then bleed air. Refer to [BR-10, "Bleeding Brake System"](#) .

1. Connect brake pipes temporarily.
2. Tighten fixing bolts.
3. Tighten brake pipes.

Tightening torque: 16.7 - 21.6 N·m (1.7 - 2.2 kg-m, 13 - 15 ft-lb)

4. Connect connector and battery cable.

A
B
C
D
E
BRC
G
H
I
J
K
L
M

PRECAUTIONS

PF0:00001

Precautions for Supplemental Restraint System (SRS) “AIR BAG” and “SEAT BELT PRE-TENSIONER”

EFS003HI

The Supplemental Restraint System such as “AIR BAG” and “SEAT BELT PRE-TENSIONER”, used along with a front seat belt, helps to reduce the risk or severity of injury to the driver and front passenger for certain types of collision. This system includes seat belt switch inputs and dual stage front air bag modules. The SRS system uses the seat belt switches to determine the front air bag deployment, and may only deploy one front air bag, depending on the severity of a collision and whether the front occupants are belted or unbelted. Information necessary to service the system safely is included in the SRS and SB section of this Service Manual.

WARNING:

- To avoid rendering the SRS inoperative, which could increase the risk of personal injury or death in the event of a collision which would result in air bag inflation, all maintenance must be performed by an authorized NISSAN/INFINITI dealer.
- Improper maintenance, including incorrect removal and installation of the SRS, can lead to personal injury caused by unintentional activation of the system. For removal of Spiral Cable and Air Bag Module, see the SRS section.
- Do not use electrical test equipment on any circuit related to the SRS unless instructed to in this Service Manual. SRS wiring harnesses can be identified by yellow and/or orange harnesses or harness connectors.

Precautions for Brake System

EFS003HJ

- Recommended fluid is brake fluid “DOT 3”.
- Never reuse drained brake fluid.
- Be careful not to splash brake fluid on painted areas such as body. If brake fluid is splashed, wipe it off and flush area with water immediately.
- Never use mineral oils such as gasoline or kerosene to clean. They will ruin rubber parts and cause improper operation.
- Using a flare nut torque wrench, securely tighten brake tube flare nuts.
- Brake system is an important safety part. If a brake fluid leak is detected, always disassemble the affected part. If a malfunction is detected, replace part with a new one.
- Before working, turn ignition switch OFF and disconnect electrical connectors of ABS actuator and electric unit (control unit) or battery terminals.
- When installing brake piping, be sure to check torque.

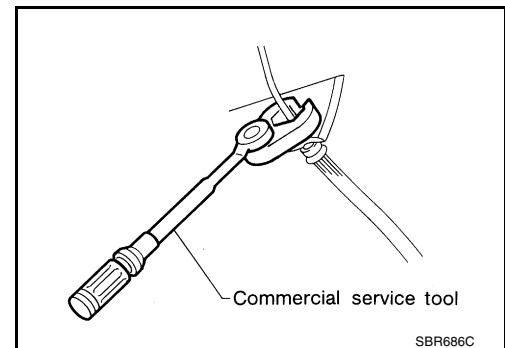

Wiring Diagrams and Trouble Diagnosis

EFS003HK

When you read wiring diagrams, refer to the following:

- [GI-13, "How to Read Wiring Diagrams"](#)
- [PG-9, "POWER SUPPLY ROUTING"](#)

When you perform trouble diagnosis, refer to the following:

- [GI-9, "HOW TO FOLLOW TEST GROUPS IN TROUBLE DIAGNOSES"](#)
- [GI-25, "How to Perform Efficient Diagnosis for an Electrical Incident"](#)

Check for any Service bulletins before servicing the vehicle.

Precautions for Brake Control

EFS003HL

- During ABS operation, brake pedal lightly vibrates and a mechanical noise may be heard. This is normal.
- Just after starting vehicle after ignition switch ON, brake pedal may vibrate or motor operating noise may be heard from engine compartment. This is a normal status of operation check.
- Stopping distance may be longer than that of vehicles without ABS when vehicle drives on rough, gravel, or snow-covered (fresh, deep snow) roads.

PRECAUTIONS

[VDC/TCS/ABS]

- When an error is indicated by ABS or another warning lamp, collect all necessary information from customer (what symptoms are present under what conditions) and check for simple causes before starting diagnostic servicing. Besides electrical system inspection, check booster operation, brake fluid level, and oil leaks.
- If tire size and type are used in an improper combination, or brake pads are not Genuine NISSAN parts, stopping distance or steering stability may deteriorate.
- If there is a radio, antenna, or antenna lead-in wire (including wiring) near control module, VDC/TCS/ABS function may have a malfunction or error.
- If aftermarket parts (car stereo, CD player, etc.) have been installed, check for incidents such as harness pinches, open circuits, and improper wiring.

Diagnosis Precaution CAN SYSTEM

EFS003HM

- Do not apply voltage of 7.0V or higher to terminal to be measured.
- Maximum open terminal voltage of tester in use shall be 7.0V or lower.
- Before checking harnesses, turn ignition switch to OFF and disconnect battery negative cable.

Precaution for Harness Repair CAN SYSTEM

EFS003HN

- Area to be repaired shall be soldered, and wrapped with a tape [be sure that fraying of twisted wire shall be within 110 mm (4.33 in)].

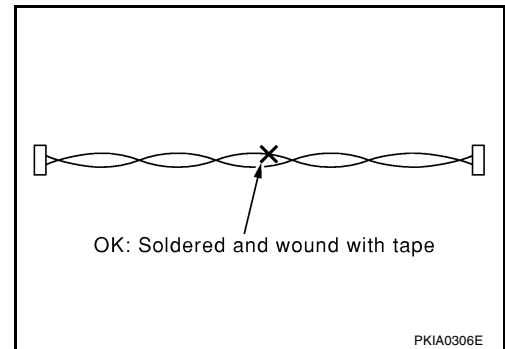

- Do not make a bypass connection to repaired area. (If it is done, branch part will be removed and characteristics of twisted wire will be lost.)

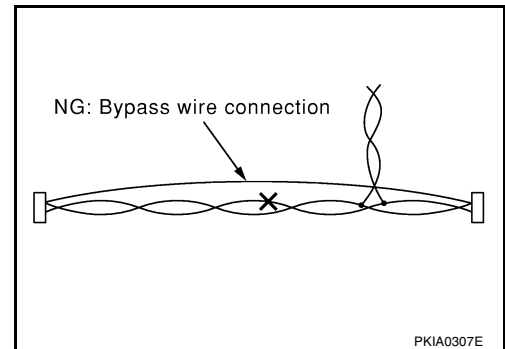

PREPARATION

[VDC/TCS/ABS]

PFP:00002

PREPARATION

Special Service Tools

EFS003HO

The actual shapes of Kent-Moore tools may differ from those of special service tools illustrated here.

Tool number (Kent-Moore No.) Tool name	Description
KV40106500 (JS25852-B) Wheel bearing puller	Removing rear wheel sensor rotor
(J-45741) ABS active wheel sensor tester	Checking operation of ABS active wheel sensor

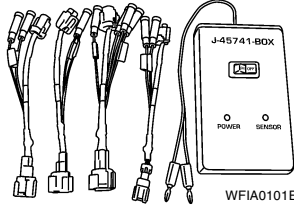
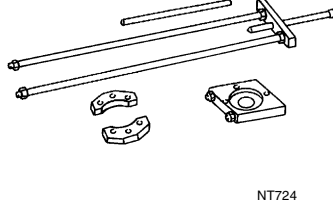

Commercial Service Tools

EFS003HP

Tool name	Description
1 Flare nut crowfoot 2 Torque wrench	Removing and installing each brake piping a: 10 mm (0.39 in) / 12 mm (0.47 in)
Rear wheel sensor rotor drift	Installing rear wheel sensor rotor a: 75 mm (2.95 in) dia. b: 63 mm (2.48 in) dia.

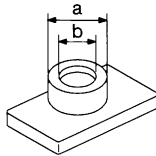
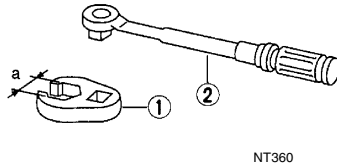

ON-VEHICLE SERVICE

Adjustment of Steering Angle Sensor Neutral Position

EFS003HQ

NOTE:

After removing/installing or replacing ABS control unit, steering angle sensor, steering components, suspension components, and tires, or after adjusting wheel alignment, make sure to adjust neutral position of steering angle sensor before running vehicle.

CAUTION:

To adjust neutral position of steering angle sensor, make sure to use CONSULT-II.
(Adjustment cannot be done without CONSULT-II.)

1. Stop vehicle with front wheels in straight-ahead position.
2. Connect CONSULT-II to data link connector on vehicle, and turn ignition switch ON (do not start engine).

CAUTION:

If CONSULT-II is used with no connection of CONSULT-II CONVERTER, malfunctions might be detected in self-diagnosis depending on control unit which carry out CAN communication.

3. Touch "ABS", "WORK SUPPORT" and "ST ANGLE SENSOR ADJUSTMENT" on CONSULT-II screen in this order.
4. Touch "START".

CAUTION:

Do not touch steering wheel while adjusting steering angle sensor.

5. After approximately 10 seconds, touch "END". (After approximately 60 seconds, it ends automatically.)

NOTE:

The CONSULT-II will display "ADJUSTMENT COMPLETE".

6. Turn ignition switch OFF, then turn it ON again.

CAUTION:

Be sure to carry out above operation.

7. Run vehicle with front wheels in straight-ahead position, then stop.
8. Select "DATA MONITOR", "SELECTION FROM MENU", and "STR ANGLE SIG" on CONSULT-II screen. Then check that "STR ANGLE SIG" is within 0 ± 3.5 deg. If value is more than specification, repeat steps 1 to 5.
9. Erase memory of ABS actuator and electric unit (control unit) and ECM.
10. Turn ignition switch to OFF.

Calibration of Decel G Sensor

EFS003HR

CAUTION:

To calibrate decel G sensor, make sure to use CONSULT-II.
(Adjustment cannot be done without CONSULT-II.)

1. Stop vehicle with front wheels in straight-ahead position.

NOTE:

Work must be done with the vehicle unladen and parked on a horizontal surface.

2. Connect CONSULT-II to data link connector on vehicle, and turn ignition switch ON (do not start engine).

CAUTION:

If CONSULT-II is used with no connection of CONSULT-II CONVERTER, malfunctions might be detected in self-diagnosis depending on control unit which carry out CAN communication.

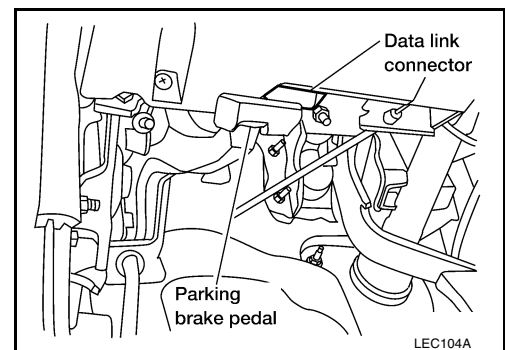
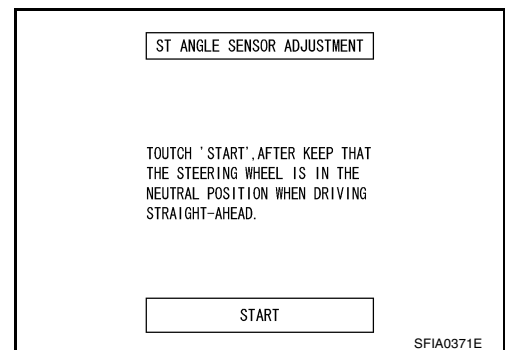
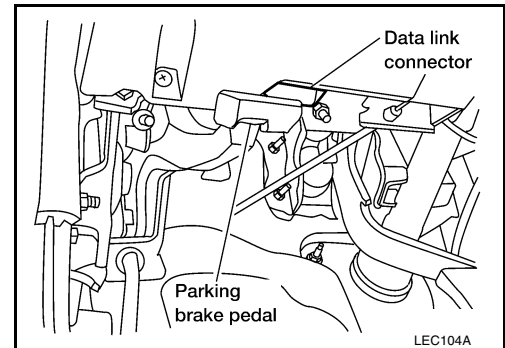

ON-VEHICLE SERVICE

[VDC/TCS/ABS]

3. Touch "ABS", "WORK SUPPORT" and "DECEL G SEN CALIBRATION" on CONSULT-II screen in this order.
4. Touch "START".
5. After approximately 10 seconds, touch "END". (After approximately 60 seconds, it ends automatically.)

NOTE:

The CONSULT-II will display "ADJUSTMENT COMPLETE".

6. Turn ignition switch OFF, then turn it ON again.

CAUTION:

Be sure to carry out above operation.

7. Run vehicle with front wheels in straight-ahead position, then stop.
8. Select "DATA MONITOR", "SELECTION FROM MENU", and "DECEL G SEN" on CONSULT-II screen. Then check that "DECEL G SEN" is within $\pm 0.08G$. If value is more than specification, repeat steps 1 to 5.
9. Erase memory of ABS actuator and electric unit (control unit) and ECM.
10. Turn ignition switch to OFF.

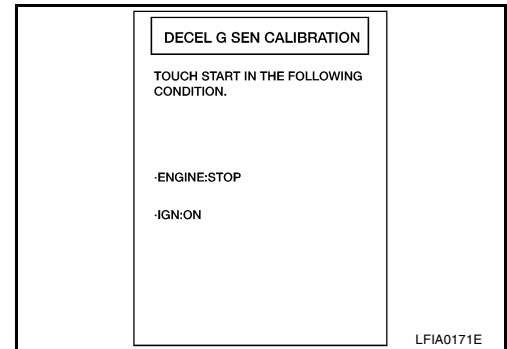

GENERAL INFORMATION

PFP:00000

**Fail-Safe
ABS SYSTEM**

EFS003HS

If a malfunction occurs in electrical system, ABS warning lamp, VDC OFF indicator lamp, and SLIP indicator lamp in combination meter turn ON. In this condition, the fail-safe function puts VDC/TCS/ABS and electronic brake force distribution (EBD) into one of the following conditions.

1. Only EBD operates. Same condition as that of models without VDC/TCS/ABS.
2. VDC/TCS/ABS and EBD do not operate. All 4 wheels operate as normal brakes.

NOTE:

In step 1 shown above, self-diagnosis when ignition switch is turned ON and when vehicle starts at initial time is carried out. ABS self-diagnosis noise may be heard as usual.

VDC/TCS SYSTEM

If a malfunction occurs in electrical system, VDC OFF indicator lamp and SLIP indicator lamp in combination meter turn on. In this condition, VDC/TCS will be deactivated and it becomes equal to that of models without VDC/TCS. However, ABS is controlled normally.

If a malfunction occurs in engine control system, VDC/TCS control will be deactivated and only ABS control will operate normally.

CAUTION:

If fail-safe mode is initiated, carry out self-diagnosis for VDC/TCS/ABS control system.

Hydraulic Circuit Diagram

EFS003HT

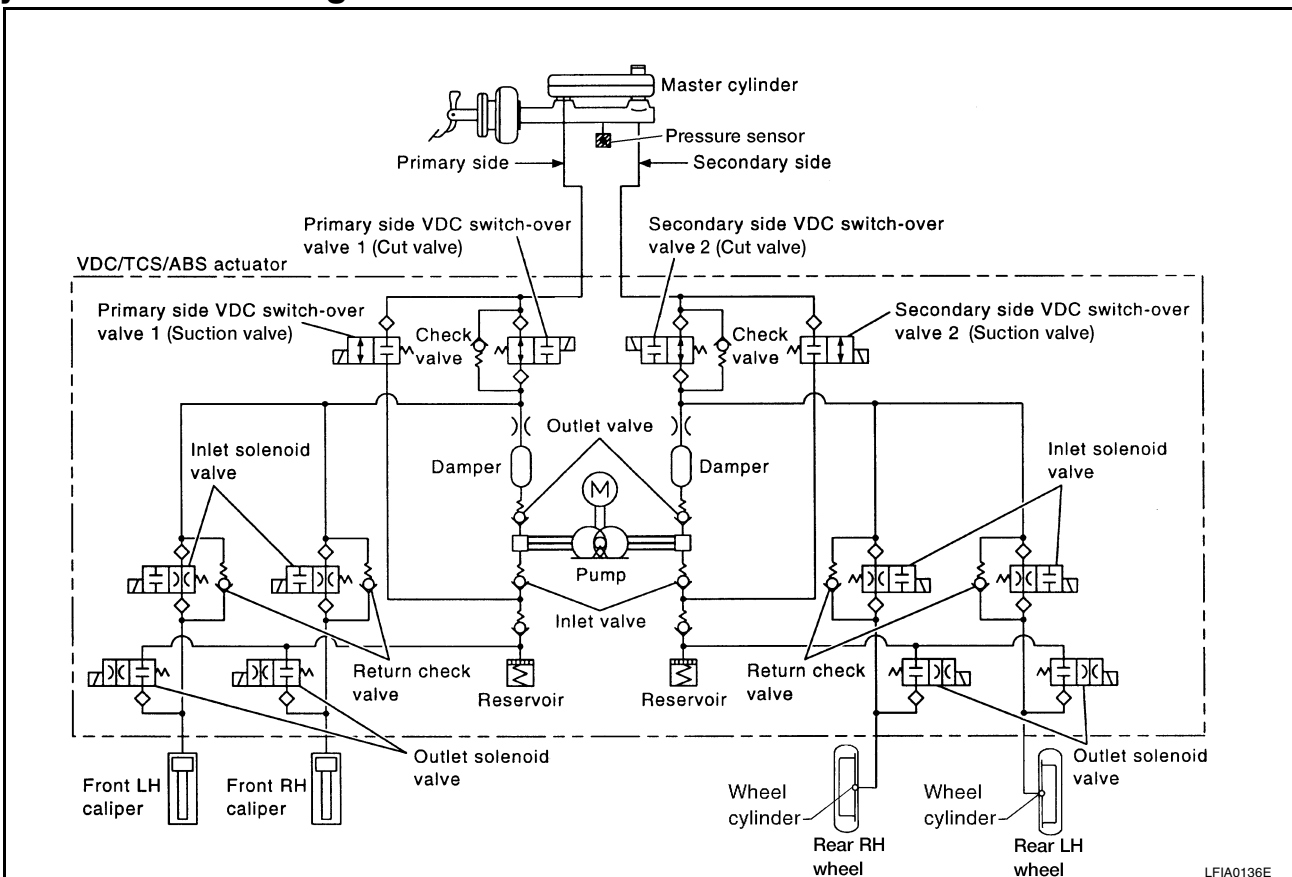

CAUTION:

- When installing parts, avoid twist and fracture conditions.
- Make sure there is no interference with other parts when turning steering both clockwise and counterclockwise.
- Brake system is an important safety part. If a brake fluid leak is detected, always disassemble the affected part. If a malfunction is detected, replace it with a new one.

ABS Function

EFS003HU

1. During ABS operation, brake pedal lightly vibrates and a mechanical noise may be heard. This is normal.
2. When starting engine, or just after starting vehicle, brake pedal may vibrate or motor operating noises may be heard from engine compartment. This is a normal status of operation check.
3. Stopping distance may be longer than that of vehicles without ABS when vehicle drives on rough, gravel, or snow-covered (fresh, deep snow) roads.
4. EBD is integrated in VDC/TCS/ABS system.

TCS Function

EFS003HV

1. VDC/TCS/ABS control unit detects a spin at drive wheels by comparing wheel speed signals from all 4 wheels. At this time, output from control unit controls brake fluid pressure to spinning wheels while cutting fuel to engine to reduce engine torque.
2. Depending on road circumstances, driver may have a sluggish feel. This is normal, because optimum traction has highest priority under TCS operation.
3. When vehicle is passing through a road where surface friction coefficient varies, downshifting/upshifting or depressing accelerator pedal fully may activate TCS temporarily.
4. During TCS operation, it informs driver of system operation by flashing SLIP indicator lamp.

VDC Function

EFS003HW

1. In addition to TCS/ABS function, VDC detects driver's steering operation amount and brake pedal travel from steering angle sensor and pressure sensor. Using information from yaw rate/side/decel G-sensor and wheel sensor, VDC judges driving condition (conditions of under steer and over steer) to improve stability by controlling brake application to 4 wheels and engine output.
2. SLIP indicator lamp flashes to inform driver of VDC operation.
3. During VDC operation, body and brake pedal lightly vibrate and mechanical noises may be heard. This is normal.
4. If vehicle is rotated on turn table, or rolled and rocked on ship, ABS warning lamp, VDC OFF indicator lamp, and SLIP indicator lamp may turn ON. In this case, start engine on normal road again. If ABS warning lamp, VDC OFF indicator lamp, and SLIP indicator lamp turn OFF after restart, it is normal.
5. When driving in steep slope such as bank, ABS warning lamp, VDC OFF indicator lamp, and SLIP indicator lamp may turn ON. In this case, start engine on normal road again. If ABS warning lamp, VDC OFF indicator lamp, and SLIP indicator lamp turn OFF after restart, it is normal.

System Diagram

EFS003HX

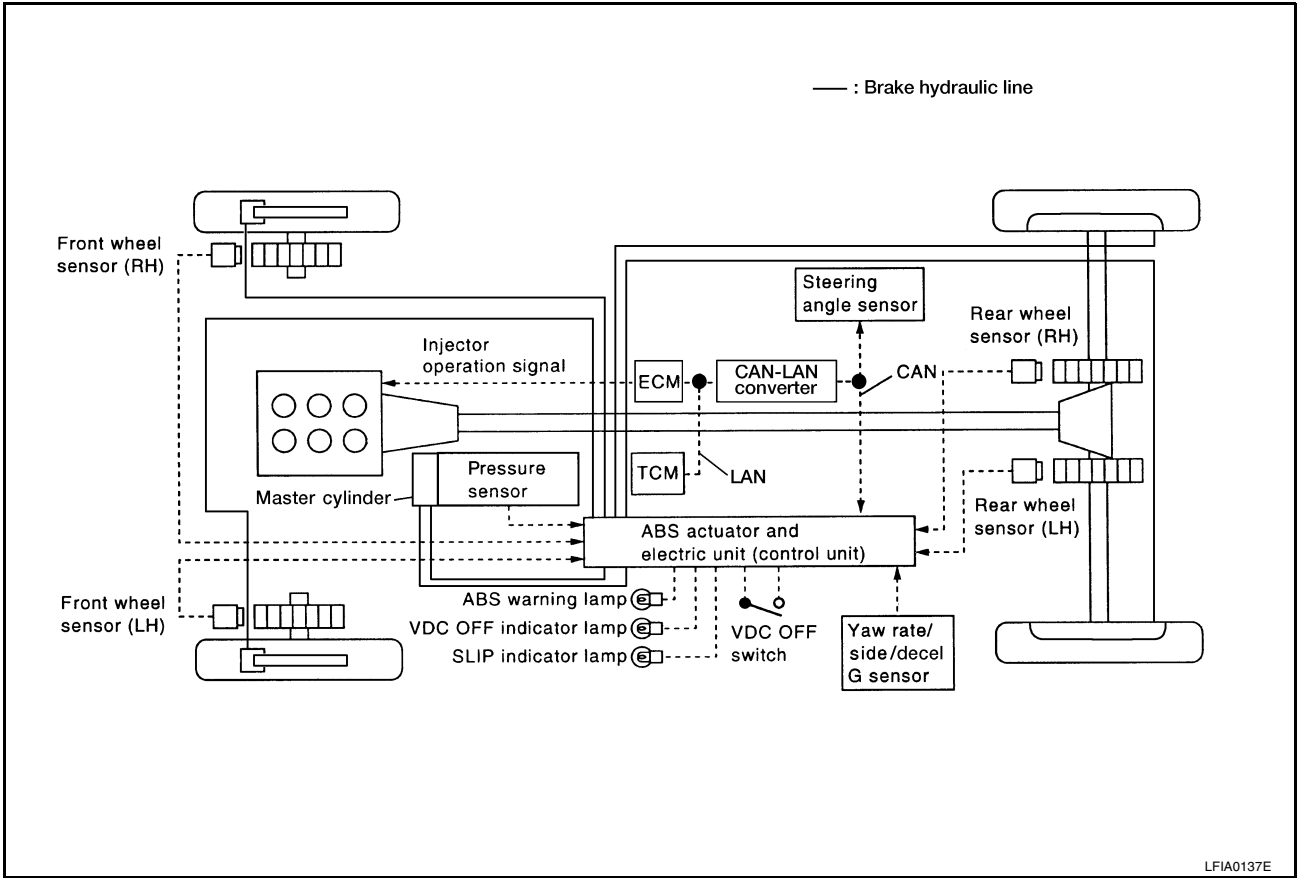

A
B
C
D
E
BRC
G
H
I
J
K
L
M

CAN COMMUNICATION

System Description

EFS003HY

CAN (Controller Area Network) is a serial communication line for real time application. It is an on-vehicle multiplex communication line with high data communication speed and excellent error detection ability. Many electronic control units are equipped onto a vehicle, and each control unit shares information and links with other control units during operation (not independent). In CAN communication, control units are connected with 2 communication lines (CAN H line, CAN L line) allowing a high rate of information transmission with less wiring. Each control unit transmits/receives data but selectively reads required data only.

SYSTEM DIAGRAM

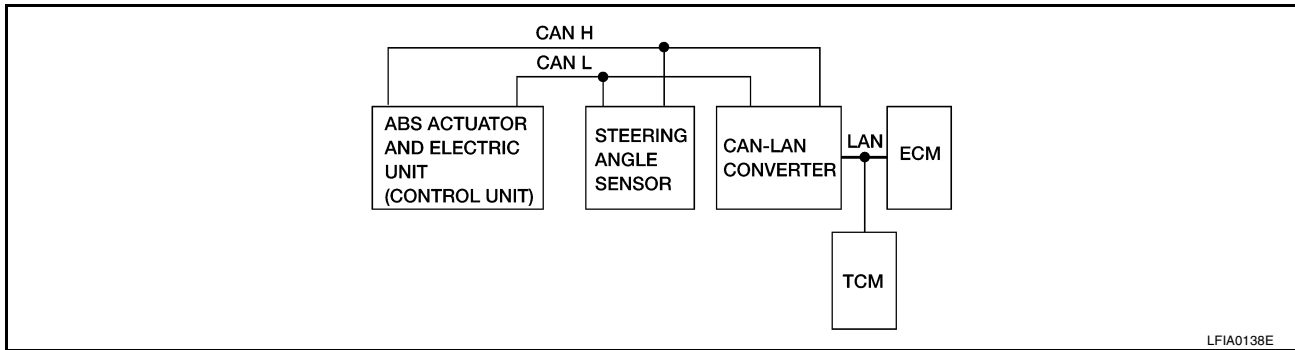

Input/output signal chart

T: Transmit R: Receive

Signals	ECM	Steering angle sensor	ABS actuator and electric unit (control unit)	TCM
Engine speed signal	T		R	
Accelerator pedal position signal	T		R	R
Steering angle sensor signal		T	R	

TROUBLE DIAGNOSIS

How to Proceed With Diagnosis
BASIC CONCEPT

- Most important point to perform diagnosis is to understand systems (control and mechanism) in vehicle thoroughly.

- It is also important to clarify customer complaints before inspection.
First of all, reproduce symptom, and understand it fully.
Ask customer about his/her complaints carefully. In some cases, it will be necessary to check symptom by driving vehicle with customer.

NOTE:

Customers are not professionals. Do not assume "maybe customer means..." or "maybe customer mentioned this symptom".

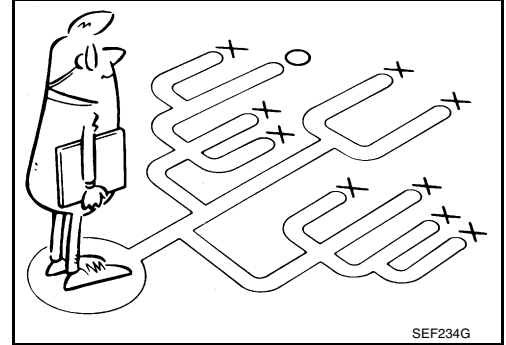

SEF234G

- It is essential to check symptoms right from beginning in order to repair a malfunction completely.
For an intermittent malfunction, it is important to reproduce symptom based on interview with customer and past examples. Do not perform inspection on ad hoc basis. Most intermittent malfunctions are caused by poor contacts. In this case, it will be effective to shake suspected harness or connector by hand. When repairs are performed without any symptom check, no one can judge if malfunction has actually been eliminated.
- After diagnosis, make sure to carry out "erase memory". Refer to [BRC-79, "Operation Procedure"](#).
- For an intermittent malfunction, move harness or harness connector by hand to check poor contact or false open circuit.
- Always read "GI General Information" to confirm general precautions.

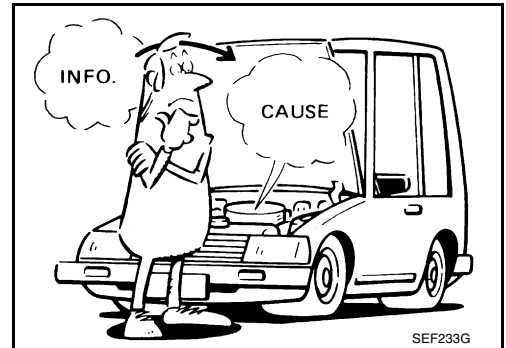

SEF233G

TROUBLE DIAGNOSIS

[VDC/TCS/ABS]

DIAGNOSIS FLOWCHART

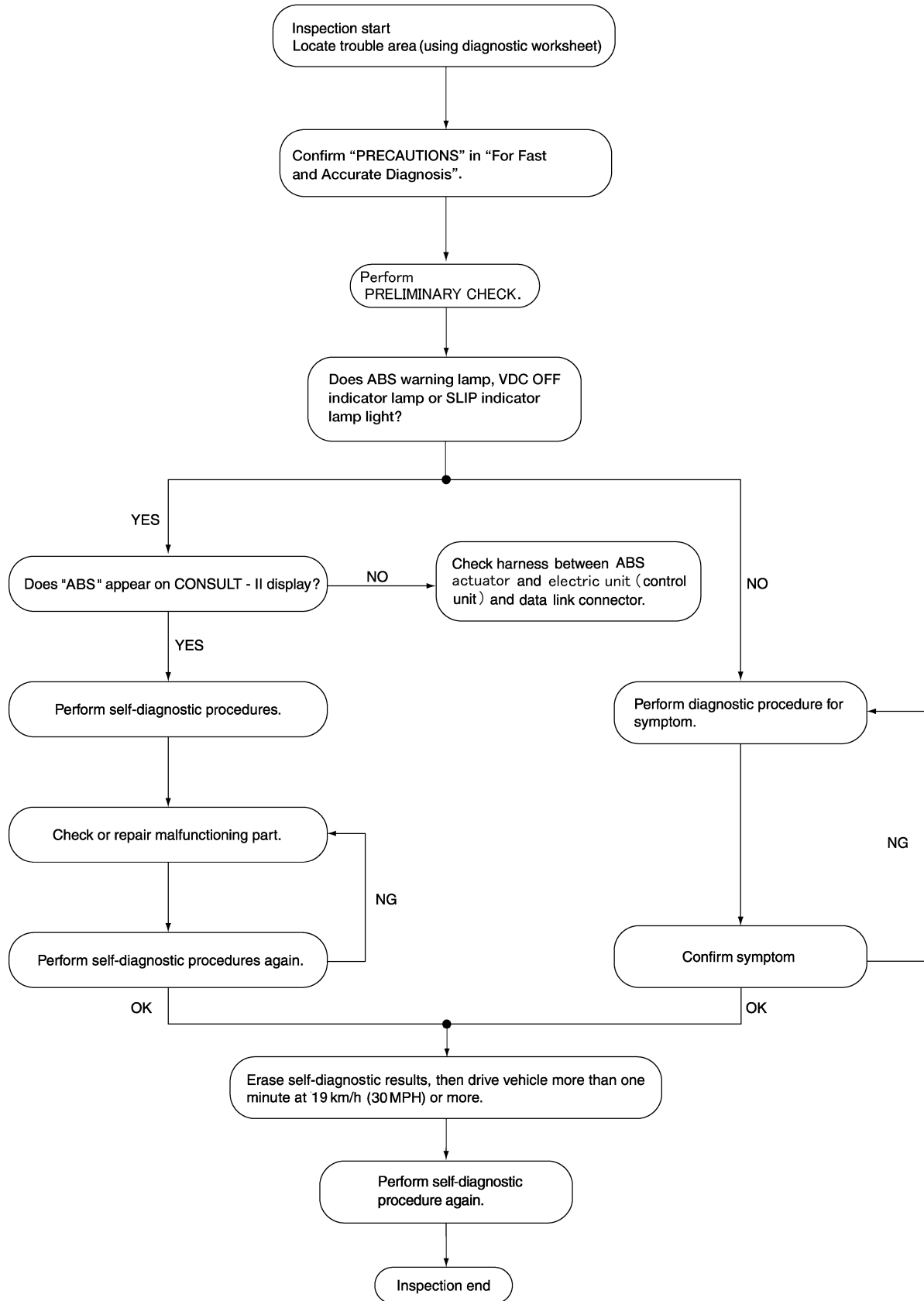

LFIA0182E

TROUBLE DIAGNOSIS

[VDC/TCS/ABS]

ASKING COMPLAINTS

- Complaints about malfunction vary depending on each person. It is important to clarify customer complaints.
- Ask customer about what symptoms are present and under what conditions. Use information to reproduce symptom while driving.
- It is also important to use diagnosis sheet so as not to miss information.

KEY POINTS

WHAT Vehicle model
WHEN Date, Frequencies
WHERE Road conditions
HOW Operating conditions,
 Weather conditions,
 Symptoms

SBR339B

EXAMPLE OF DIAGNOSIS SHEET

Customer name MR/MS	Model & Year		VIN
Engine #	Trans.		Mileage
Incident Date	Manuf. Date		In Service Date
Symptoms	<input type="checkbox"/> Noise and vibration (from engine compartment) <input type="checkbox"/> Noise and vibration (from axle)	<input type="checkbox"/> Warning / Indicator activate	<input type="checkbox"/> Firm pedal operation Large stroke pedal operation
	<input type="checkbox"/> TCS does not work (Rear wheels slip when accelerating : 2 WD mode)	<input type="checkbox"/> ABS does not work. (wheels slip when braking)	<input type="checkbox"/> Lack of sense of acceleration
Engine conditions	<input type="checkbox"/> When starting <input type="checkbox"/> After starting		
Road conditions	<input type="checkbox"/> Low friction road (<input type="checkbox"/> Snow <input type="checkbox"/> Gravel <input type="checkbox"/> Other) <input type="checkbox"/> Bumps / potholes		
Driving conditions	<input type="checkbox"/> Full-acceleration <input type="checkbox"/> High speed cornering <input type="checkbox"/> Vehicle speed: Greater than 10 km/h (6 MPH) <input type="checkbox"/> Vehicle speed: 10 km/h (6 MPH) or less <input type="checkbox"/> Vehicle is stopped		
Applying brake conditions	<input type="checkbox"/> Suddenly <input type="checkbox"/> Gradually		
Other conditions	<input type="checkbox"/> Operation of electrical equipment <input type="checkbox"/> Shift change <input type="checkbox"/> Other descriptions		

LFIA0183E

Component Installation Location

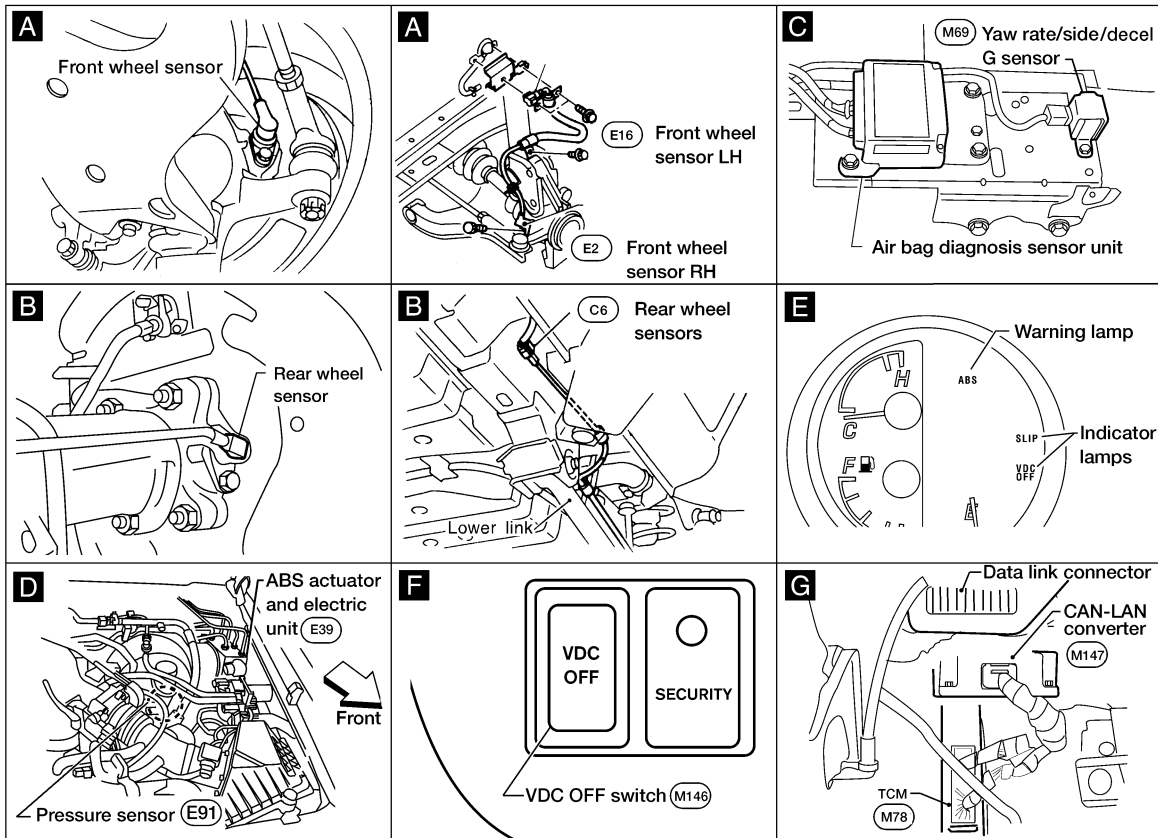
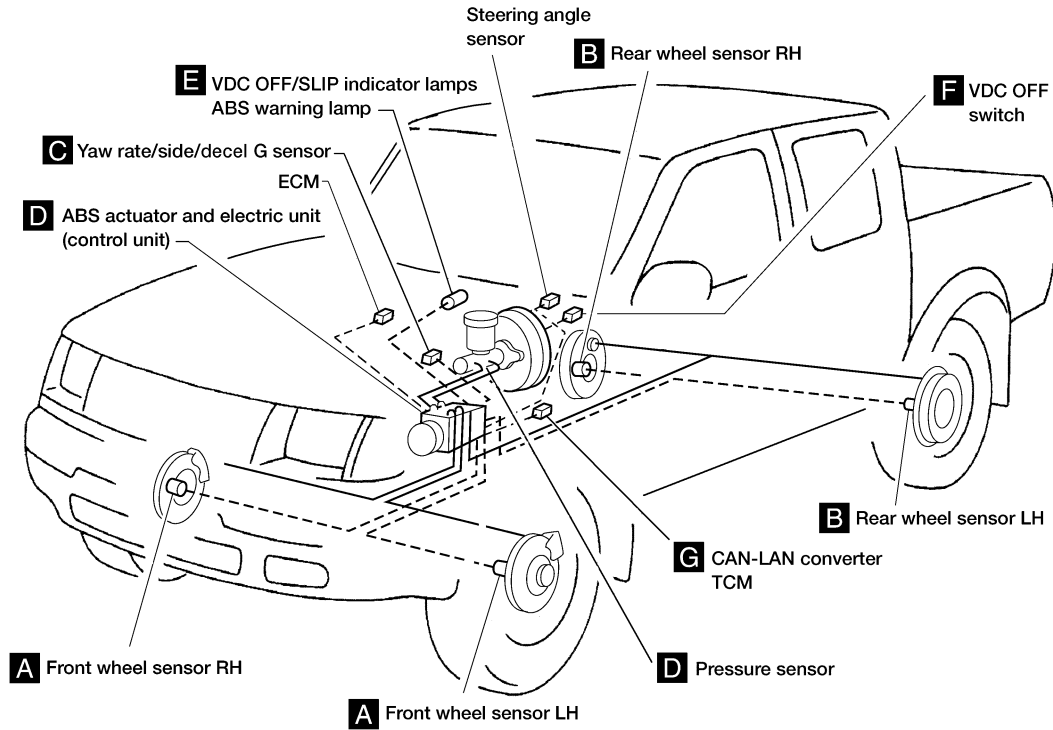

TROUBLE DIAGNOSIS

[VDC/TCS/ABS]

Schematic

EFS00311

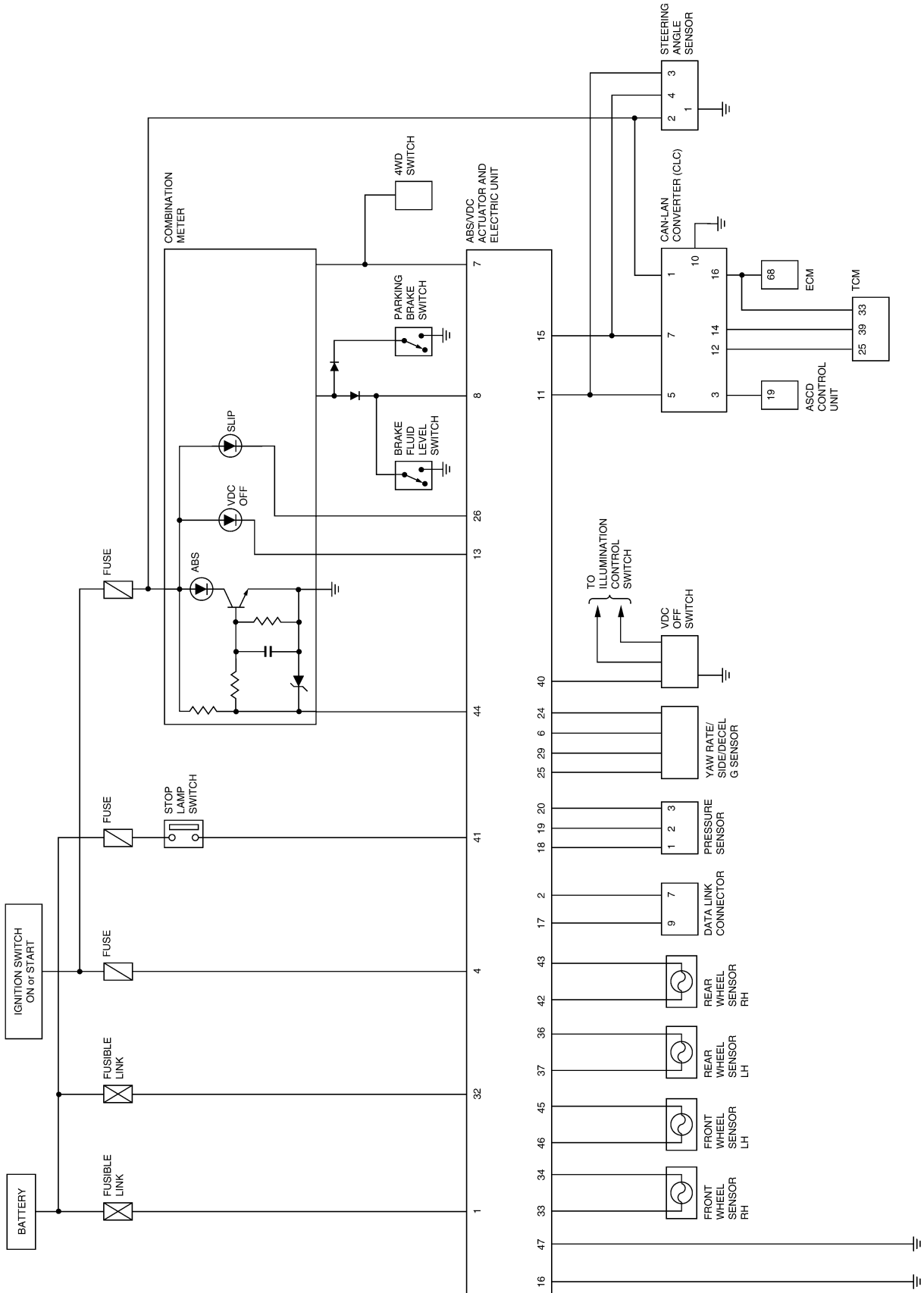

LFWA0025E

A
B
C
D
E
BRC
G
H
I
J
K
L
M

TROUBLE DIAGNOSIS

[VDC/TCS/ABS]

Wiring Diagram — VDC —

EFS00312

BRC-VDC-01

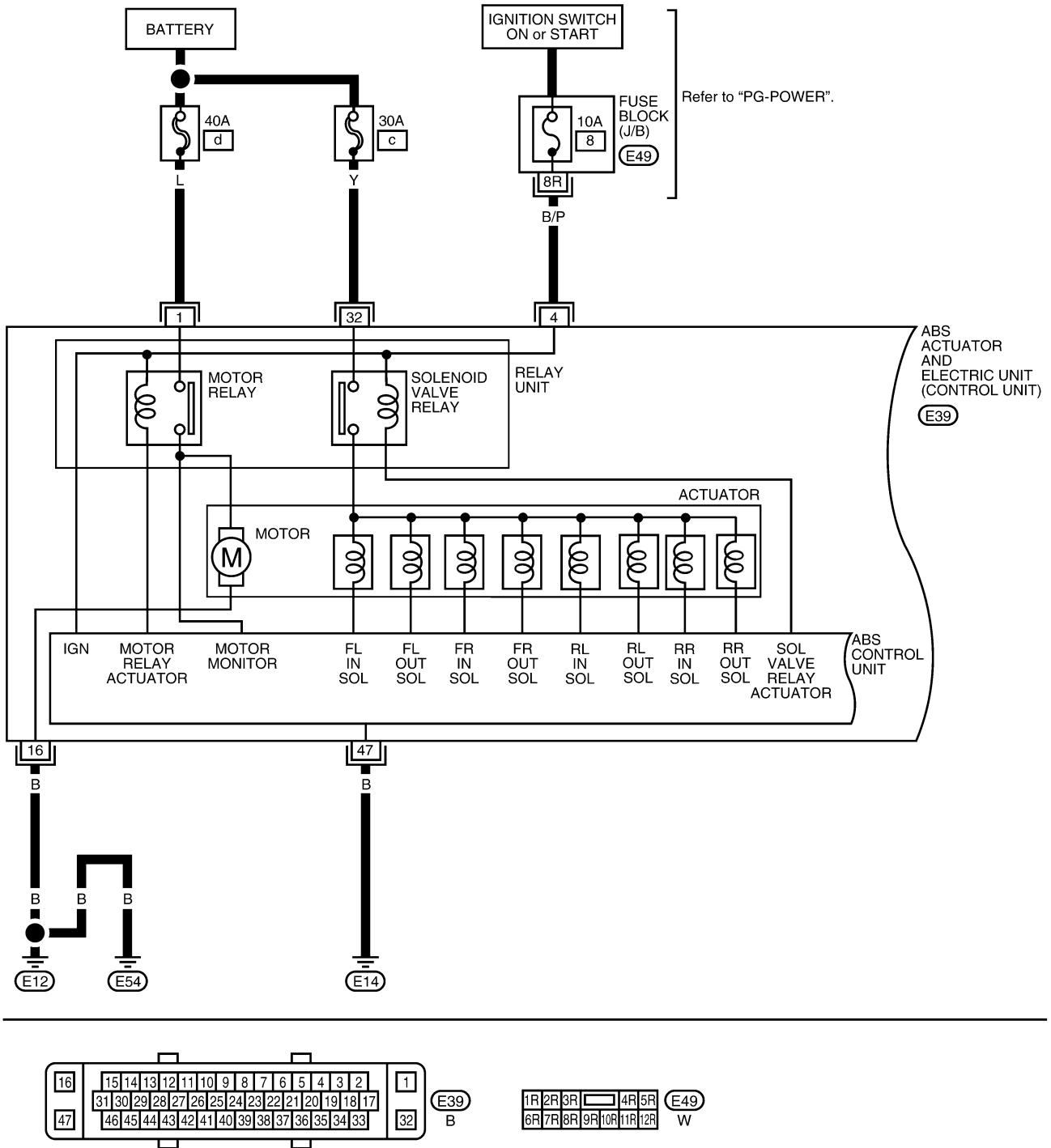

LFWA0026E

TROUBLE DIAGNOSIS

[VDC/TCS/ABS]

BRC-VDC-02

A
B
C
D
E
BRC
G
H
I
J
K
L
M

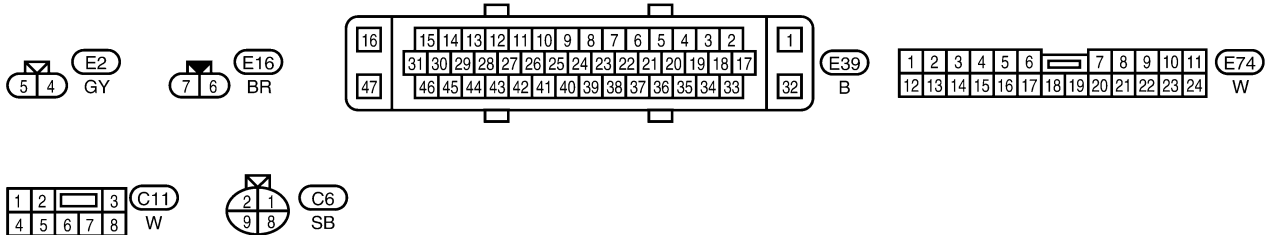
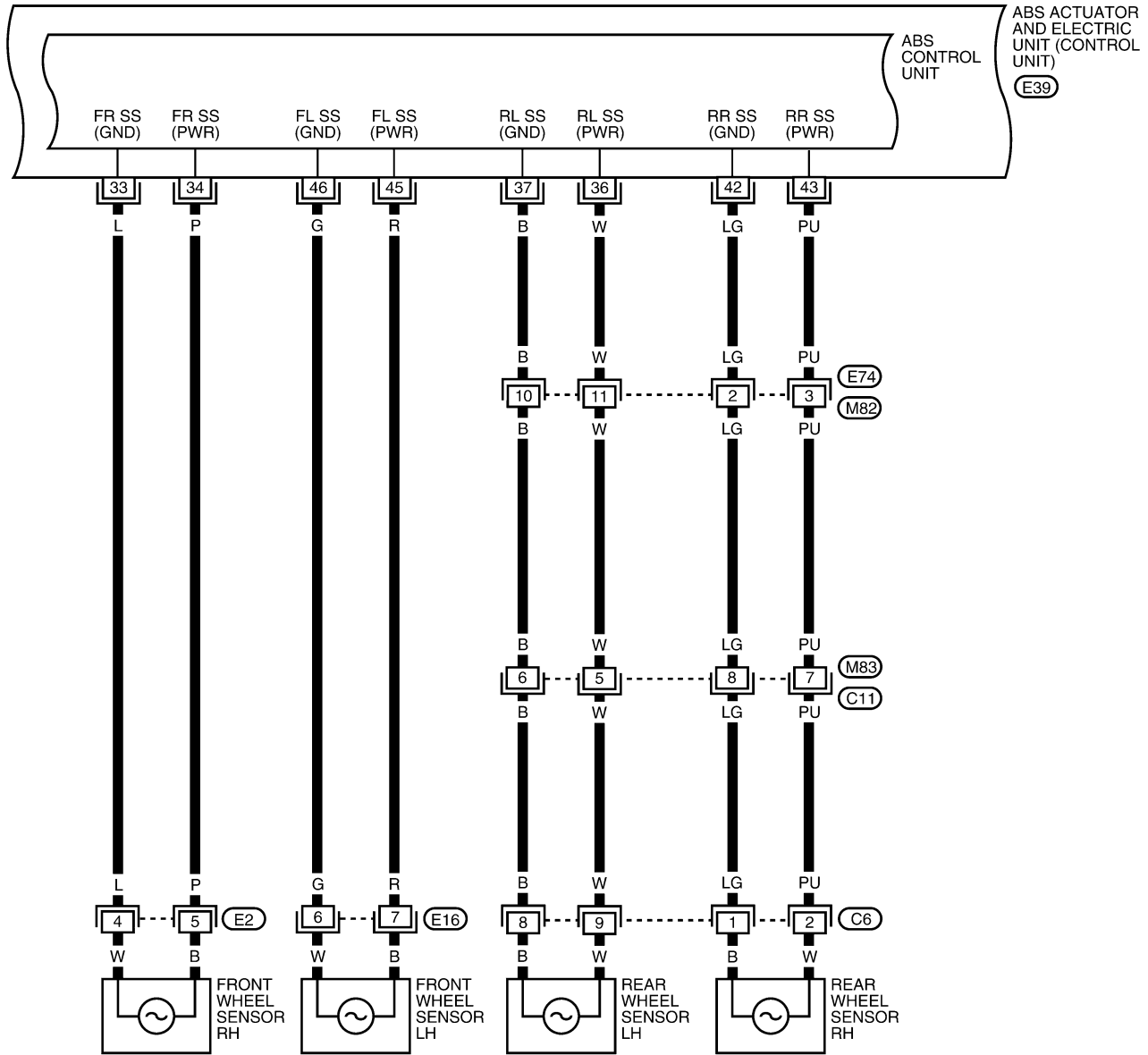

LFWA0027E

TROUBLE DIAGNOSIS

[VDC/TCS/ABS]

BRC-VDC-03

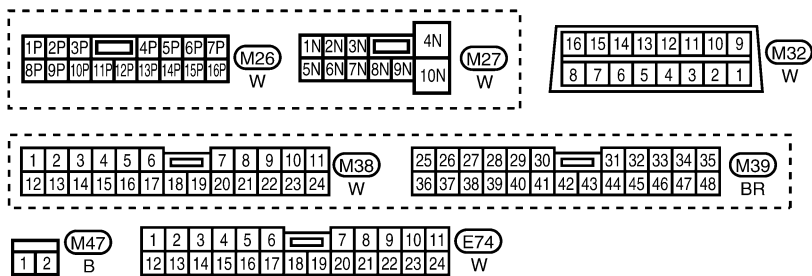
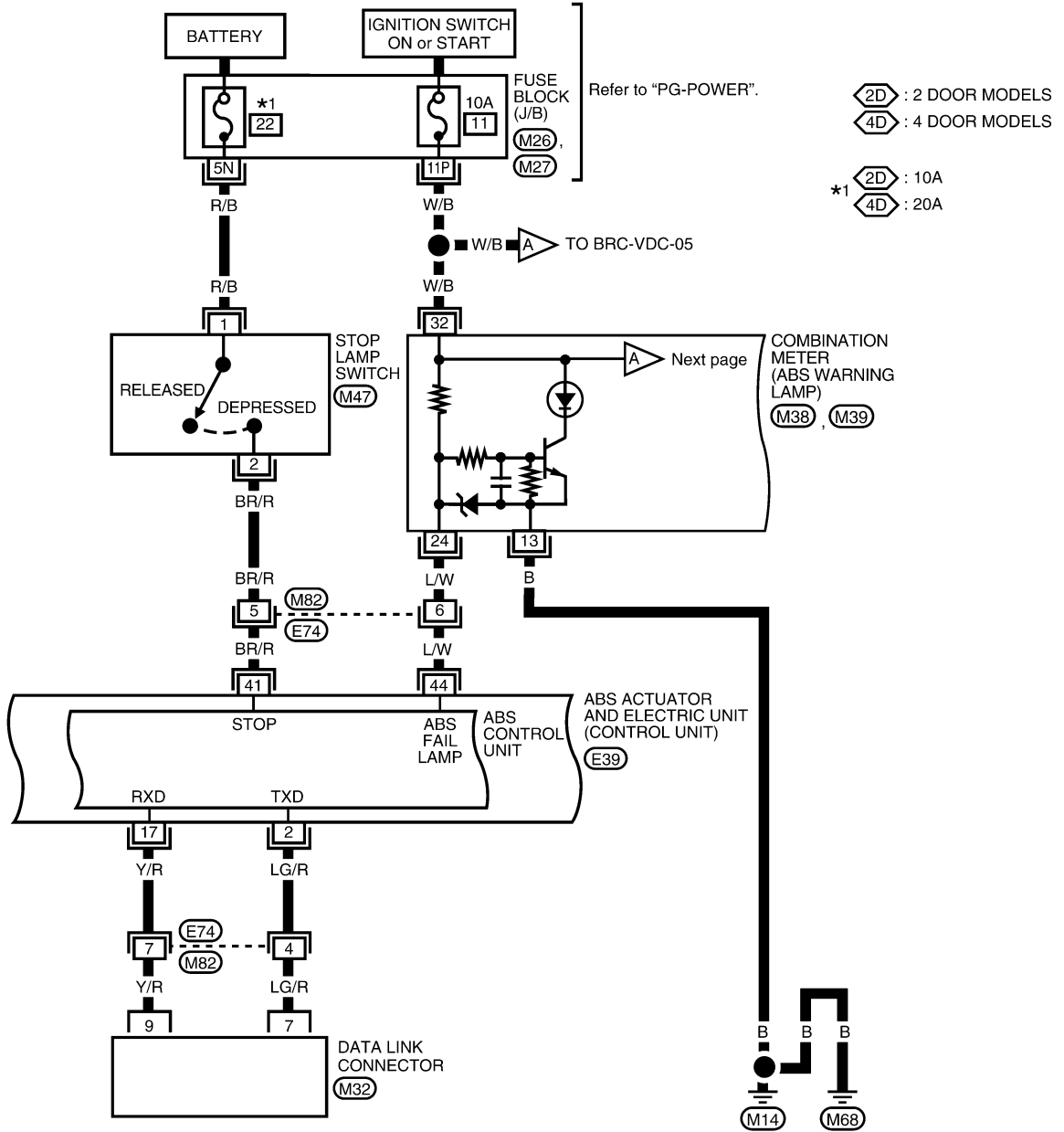

Refer to the following.
(E39) - ELECTRICAL UNITS

TROUBLE DIAGNOSIS

[VDC/TCS/ABS]

BRC-VDC-04

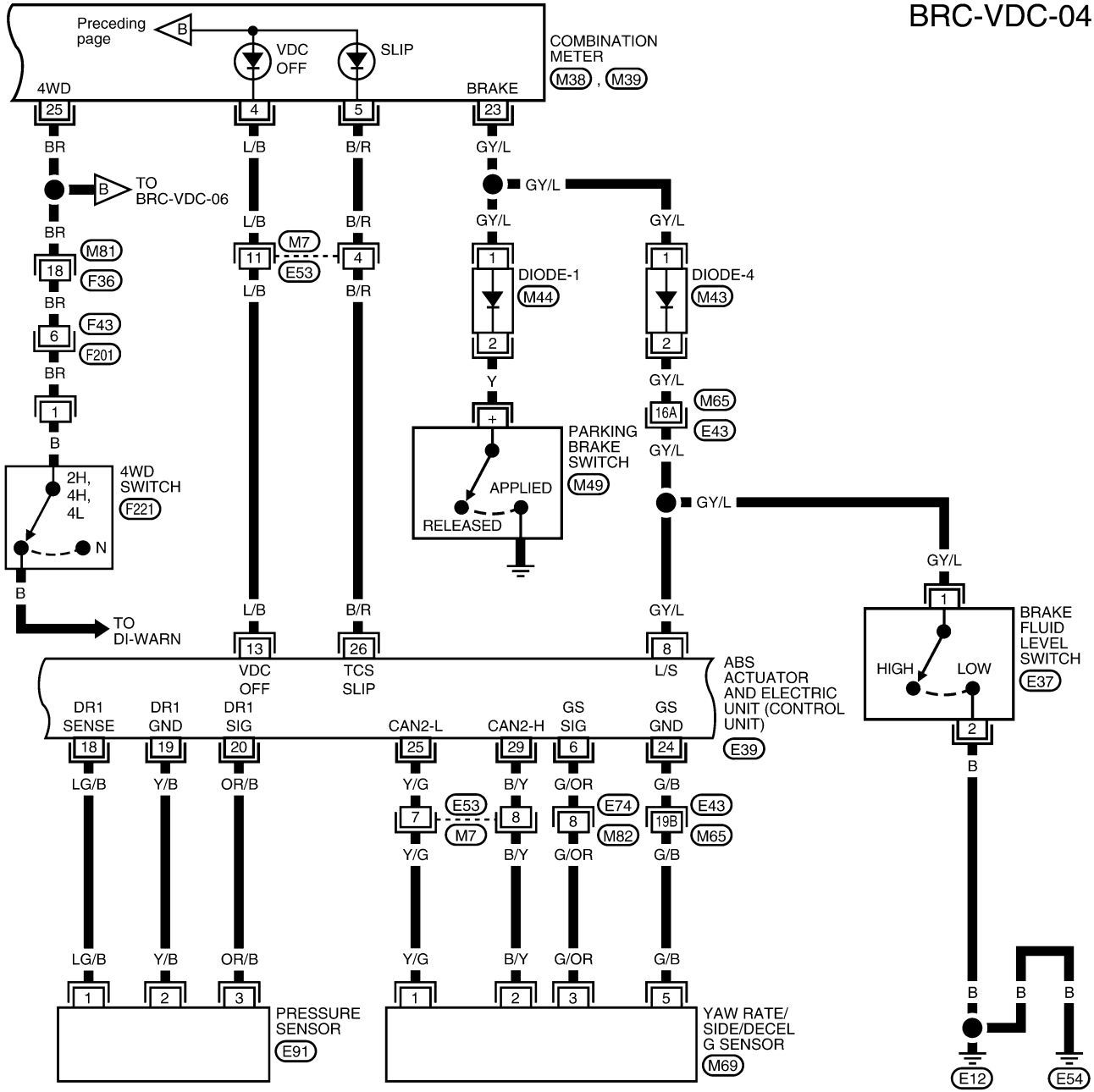

A
B
C
D
E
BRC
G
H
I
J
K
L
M

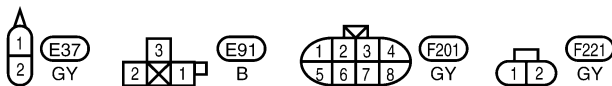
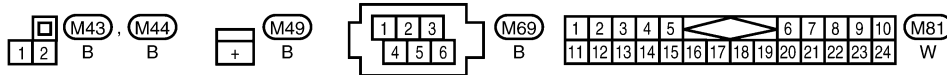
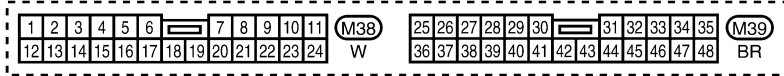
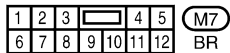

Refer to the following.
 (E39) - ELECTRICAL UNITS
 (E43) - SUPER MULTIPLE JUNCTION (SMJ)

TROUBLE DIAGNOSIS

[VDC/TCS/ABS]

BRC-VDC-05

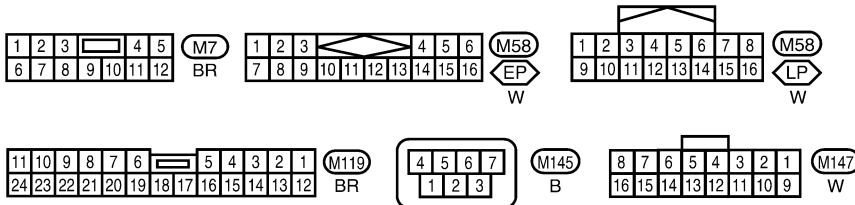
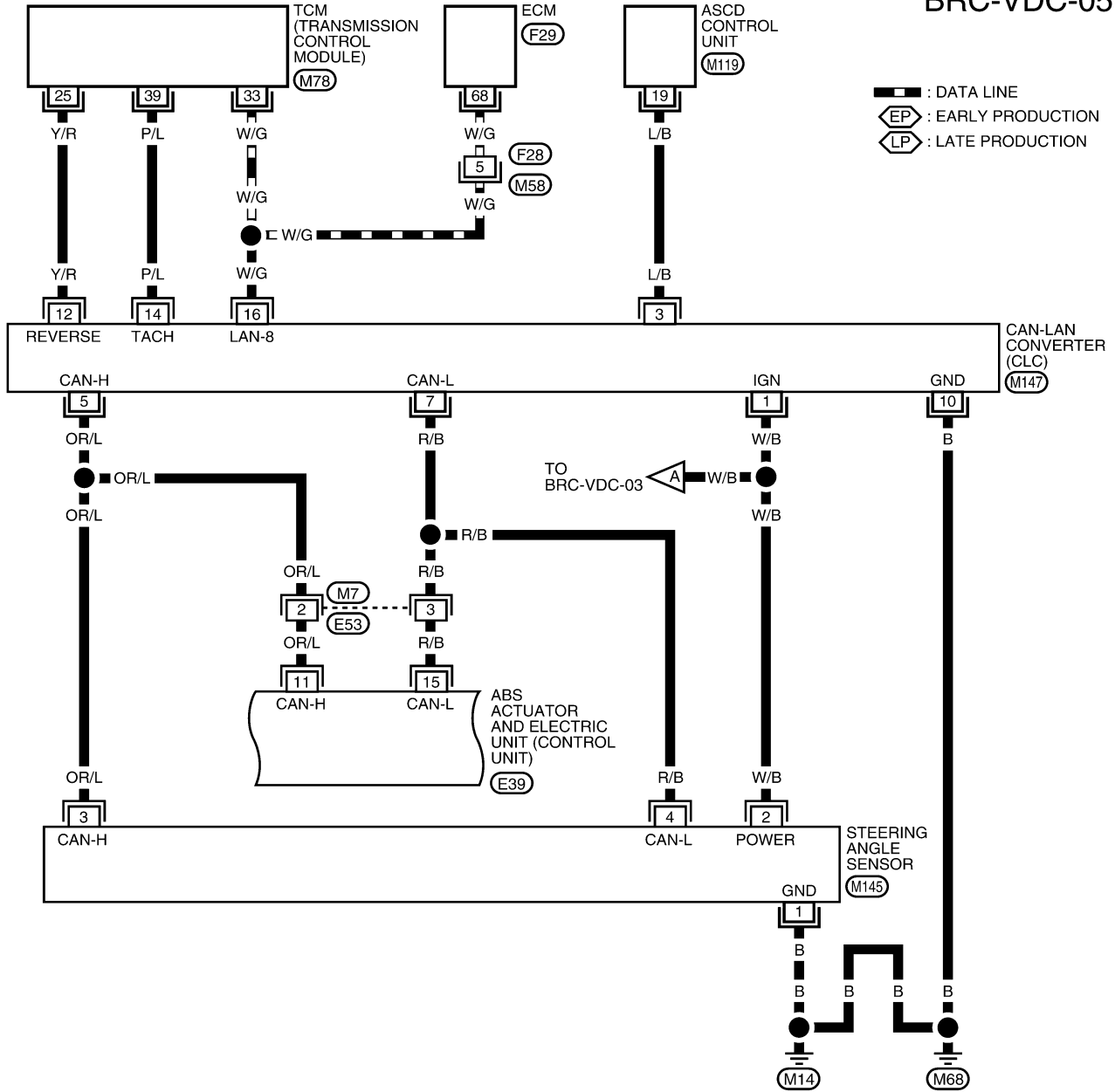

Refer to the following.
 (M78), (E39), (F29) -
 ELECTRICAL UNITS

TROUBLE DIAGNOSIS

[VDC/TCS/ABS]

BRC-VDC-06

A
B
C
D
E
BRC
G
H
I
J
K
L
M

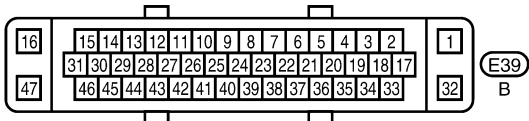
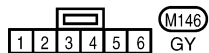
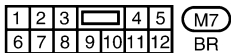
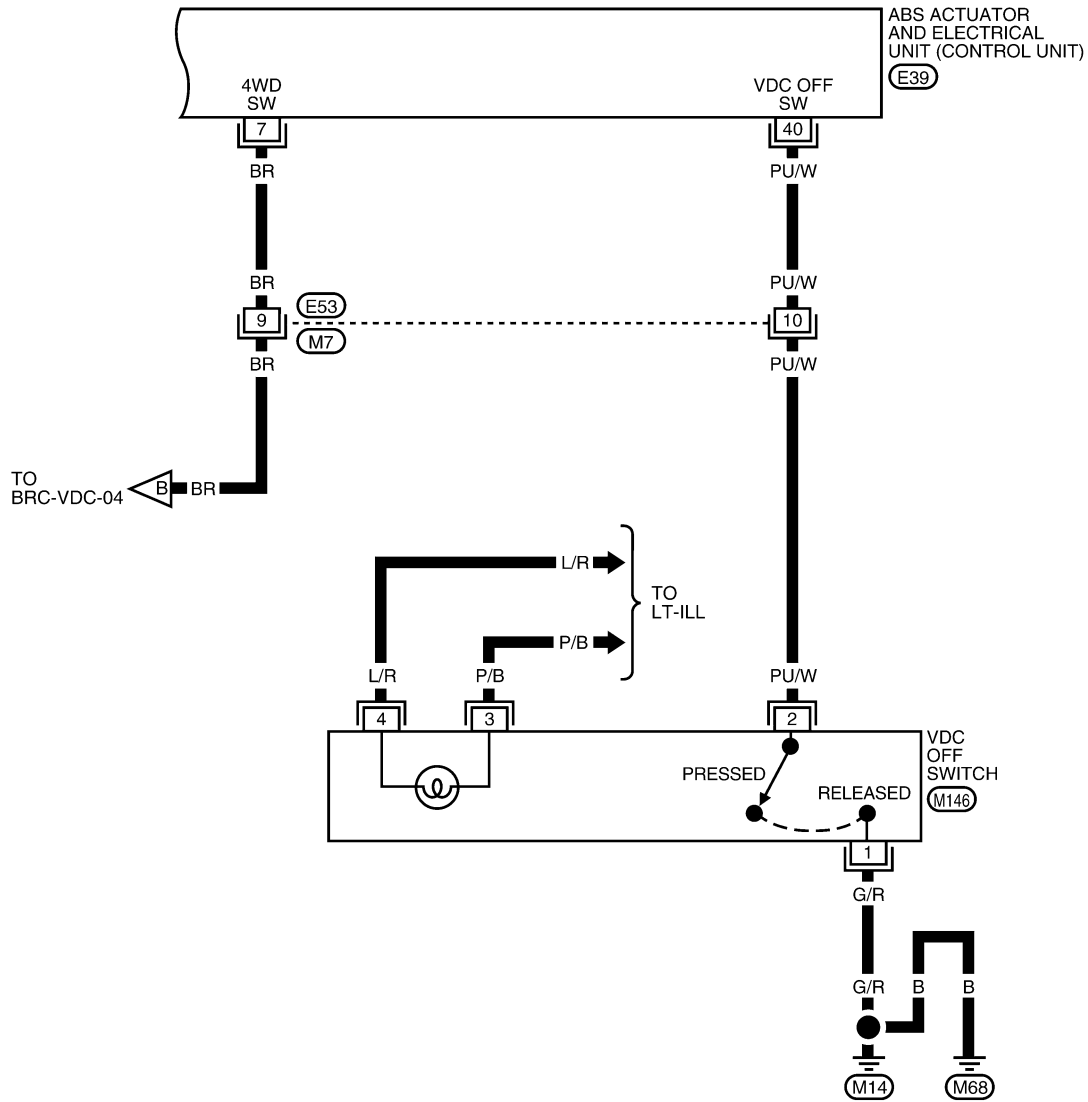

LFWA0031E

TROUBLE DIAGNOSIS

[VDC/TCS/ABS]

ABS Actuator and Electric Unit (Control Unit) Input/Output Signal Standard EF50033

STANDARDS USING CIRCUIT TESTER AND OSCILLOSCOPE

CAUTION:

Connect ABS actuator and electric unit (control unit) connector, and then turn ignition switch ON.

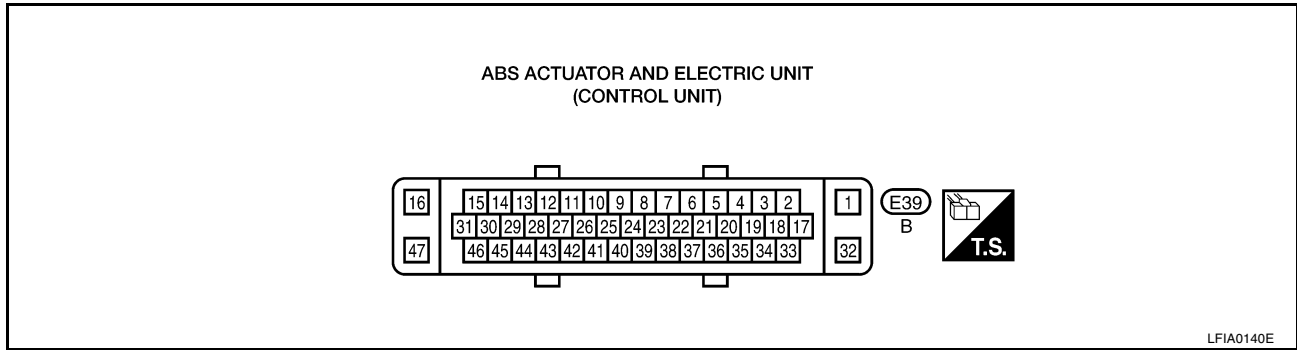

Measurement terminal		Measuring point	Standard value (Note 1)		Note: Error inspection checklist
+	-				
1		Actuator motor	Actuator motor being driven	Approx. 12V	BRC-101. "Inspection 7 Actuator Motor, Motor Relay, and Circuit"
			Actuator motor stopped	Approx. 12V	
4		Power supply (IGN)	Ignition switch ON	Approx. 12V	BRC-103. "Inspection 9 ABS Actuator and Electric Unit (Control Unit) Power Supply and Ground Circuit"
6		Yaw rate/side/decel G sensor	Power	Approx. 8V to 16V	BRC-98. "Inspection 5 Yaw Rate/Side/Decel G Sensor and Circuit Between Yaw Rate/Side/Decel G Sensor and ABS Actuator and Electric Unit (Control Unit)"
7	Body ground	4WD switch	4WD is ON	Approx. 12V	4WD switch and circuit
			4WD is OFF	Approx. 0V	
8		Brake fluid level switch	Brake fluid is not enough	Approx. 12V	BRC-105. "Inspection 11 Brake Fluid Level in Reservoir Tank. Communication Circuit Between ABS Actuator and Electric Unit (Control Unit) and Brake Fluid Level Switch"
			Brake fluid is enough	Approx. 0V	
11		CAN communication input/output signal (H)	Ignition switch ON		BRC-119. "Inspection 23 CAN CIRCUIT 1 - CAN Communication System Failure"

TROUBLE DIAGNOSIS

[VDC/TCS/ABS]

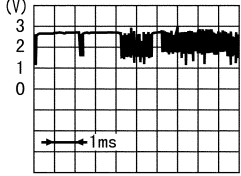
Measurement terminal		Measuring point	Standard value (Note 1)		Note: Error inspection checklist
+	-				
13		VDC OFF indicator lamp	VDC OFF indicator lamp ON (Note 4)	Approx. 12V	BRC-115. "Inspection 20 VDC OFF Indicator Lamp Does Not Come On When Ignition Switch Is Turned On"
			VDC OFF indicator lamp OFF (Note 4)	Approx. 0V	
15	Body ground	CAN communication input/output signal (L)	Ignition switch ON	 <p style="text-align: right; font-size: small;">PBIA0223J</p>	BRC-119. "Inspection 23 CAN CIRCUIT 1 - CAN Communication System Failure"
16	Body ground	Ground	—	Approx. 0Ω	BRC-103. "Inspection 9 ABS Actuator and Electric Unit (Control Unit) Power Supply and Ground Circuit"
18			Power	Approx. 5V	BRC-96. "Inspection 3 Pressure Sensor and Circuit Between Pressure Sensor and ABS Actuator and Electric Unit (Control Unit)"
19			Ground	Approx. 0V	
20			Output signal	Approx. 0.5V to 4.5V	
24			Ground	Approx. 0Ω	BRC-98. "Inspection 5 Yaw Rate/Side/Decel G Sensor and Circuit Between Yaw Rate/Side/Decel G Sensor and ABS Actuator and Electric Unit (Control Unit)"
25	—	Yaw rate/side/decel G sensor	CAN-L	—	BRC-98. "Inspection 5 Yaw Rate/Side/Decel G Sensor and Circuit Between Yaw Rate/Side/Decel G Sensor and ABS Actuator and Electric Unit (Control Unit)"
26	Body ground	SLIP indicator lamp	SLIP indicator lamp ON (Note 5)	Approx. 0V	BRC-113. "Inspection 19 SLIP Indicator Lamp Does Not Come On When Ignition Switch is Turned On"
			SLIP indicator lamp OFF (Note 5)	Approx. 12V	
29	—	Yaw rate/side/decel G sensor	CAN-H	—	BRC-98. "Inspection 5 Yaw Rate/Side/Decel G Sensor and Circuit Between Yaw Rate/Side/Decel G Sensor and ABS Actuator and Electric Unit (Control Unit)"
32	Body ground	Solenoid valve	Valve is active	Approx. 12V	BRC-99. "Inspection 6 Solenoid, VDC Switching Valve, Actuator Relay and Circuits"
			Valve is inactive	Approx. 12V	

A
B
C
D
E
BRC
G
H
I
J
K
L
M

TROUBLE DIAGNOSIS

[VDC/TCS/ABS]

Measurement terminal		Measuring point	Standard value (Note 1)		Note: Error inspection checklist
+	-				
—	—	Front RH wheel sensor	—	—	BRC-94. "Inspection 1 Wheel Sensor System"
—	—	Rear LH wheel sensor	—	—	
40	Body ground	VDC OFF switch	VDC OFF switch pressed	Approx. 0V	BRC-116. "Inspection 21 VDC OFF Switch Is Inoperative"
			VDC OFF switch released	Approx. 12V	
41		Stop lamp signal	Brake pedal depressed	Approx. 12V	BRC-102. "Inspection 8 Stop Lamp Switch and Circuit"
			Brake pedal not depressed	Approx. 0V	
—	—	Rear RH wheel sensor	—	—	BRC-94. "Inspection 1 Wheel Sensor System"
44	Body ground	ABS warning lamp	ABS warning lamp ON (Note 3)	Approx. 12V	BRC-119. "Inspection 25 ABS Warning Lamp Does Not Come On When Ignition Switch Is Turned On"
			ABS warning lamp OFF (Note 3)	Approx. 0V	
—	—	Front LH wheel sensor	—	—	BRC-94. "Inspection 1 Wheel Sensor System"
47	Body ground	Ground	—	Approx. 0Ω	BRC-103. "Inspection 9 ABS Actuator and Electric Unit (Control Unit) Power Supply and Ground Circuit"

Note 1: When standard value is checked using a circuit tester for voltage measurement, care must be taken to avoid damage to connector terminals.

Note 2: Confirm tire pressure is normal.

Note 3: ON/OFF timing of ABS warning lamp

ON: For approximately 2 seconds after ignition switch is turned ON, or when a malfunction is detected.

OFF: Approximately 2 seconds after ignition switch is turned ON (when system is in normal operation) and VDC/TCS function is not activated.

Note 4: ON/OFF timing of VDC OFF indicator lamp

ON: For approximately 2 seconds after ignition switch is turned ON, or when a malfunction is detected and VDC OFF switch is ON.

OFF: Approximately 2 seconds after ignition switch is turned ON (when system is in normal operation).

Note 5: SLIP indicator lamp ON/OFF timing

ON: For approximately 2 seconds after ignition switch is turned ON, or when a malfunction is detected and VDC/TCS function is activated while driving.

OFF: Approximately 2 seconds after ignition switch is turned ON (when system is in normal operation) and VDC/TCS function is not activated.

Flashing: VDC/TCS function is active during driving

STANDARDS BY CONSULT-II

CAUTION:

Items displayed are data calculated by the control unit and may indicate normal operation even if output circuit (harness) is open or shorted.

TROUBLE DIAGNOSIS

[VDC/TCS/ABS]

Monitor item	Display content	Data monitor		Note: Error inspection checklist
		Condition	Reference value in normal operation	
SLCT LVR POSI	PNP, reverse switch signal ON/OFF condition	A/T shift position = N or P position	N / P	PNP, reverse switch circuit
		A/T shift position = Reverse position	R	
		A/T shift position = other than N, P and reverse position	D	
GEAR	A/T gear position	1:1st gear 2:2nd gear 3:3rd gear 4:4th gear		<ul style="list-style-type: none"> Communication circuit between TCM and CLC CAN circuit
FR RH SENSOR FR LH SENSOR RR RH SENSOR RR LH SENSOR	Wheel speed	Vehicle stopped	0 [km/h (MPH)]	BRC-94, "Inspection 1 Wheel Sensor System"
		Vehicle running (Note 1)	Almost in accordance with speedometer display (within $\pm 10\%$)	
ACCEL POS SIG	Open/close condition of throttle valve (linked with accelerator pedal).	Accelerator pedal not depressed (ignition switch is ON)	0%	<ul style="list-style-type: none"> Communication circuit between CLC and ECM CAN circuit
		Depress accelerator pedal (engine running)	0 to 100%	
ENGINE SPEED	With engine running	Engine running	Almost in accordance with tachometer display	BRC-108, "Inspection 14 ENG SPEED SIG - Engine Speed Signal"
STR ANGLE SIG	Steering angle detected by steering angle sensor	Straight-ahead	Approx. 0 deg	BRC-97, "Inspection 4 Steering Angle Sensor and Circuit Between Steering Angle Sensor and ABS Actuator and Electric Unit (Control Unit)"
		Steering wheel turned	-756 to 756 deg	
YAW RATE SEN	Yaw rate detected by yaw rate sensor	Vehicle stopped	Approx. 0 d/s	BRC-98, "Inspection 5 Yaw Rate/Side/Decel G Sensor and Circuit Between Yaw Rate/Side/Decel G Sensor and ABS Actuator and Electric Unit (Control Unit)"
		Vehicle running	-100 to 100 d/s	
SIDE G SENSOR	Transverse G detected by side G-sensor	Vehicle stopped	Approx. 0 m/s ²	BRC-98, "Inspection 5 Yaw Rate/Side/Decel G Sensor and Circuit Between Yaw Rate/Side/Decel G Sensor and ABS Actuator and Electric Unit (Control Unit)"
		Vehicle running	-16.7 to 16.7 m/s ²	
PRESS SENSOR	Brake fluid pressure detected by pressure sensor	With ignition switch turned ON and brake pedal released	Approx. 0 bar	BRC-96, "Inspection 3 Pressure Sensor and Circuit Between Pressure Sensor and ABS Actuator and Electric Unit (Control Unit)"
		With ignition switch turned ON and brake pedal depressed	0 to 350 bar	
BATTERY VOLT	Battery voltage supplied to ABS actuator and electric unit (control unit)	Ignition switch ON	10 to 16V	BRC-103, "Inspection 9 ABS Actuator and Electric Unit (Control Unit) Power Supply and Ground Circuit"

A

B

C

D

E

BRC

G

H

I

J

K

L

M

TROUBLE DIAGNOSIS

[VDC/TCS/ABS]

Monitor item	Display content	Data monitor		Note: Error inspection checklist
		Condition	Reference value in normal operation	
STOP LAMP SW	Brake pedal operation	Brake pedal depressed	ON	BRC-102, "Inspection 8 Stop Lamp Switch and Circuit"
		Brake pedal not depressed	OFF	
OFF SW	VDC OFF switch ON/OFF status	VDC OFF switch ON (When VDC OFF indicator lamp is ON)	ON	BRC-116, "Inspection 21 VDC OFF Switch Is Inoperative"
		VDC OFF switch OFF (When VDC OFF indicator lamp is OFF)	OFF	
ABS WARN LAMP	ABS warning lamp ON condition (Note 2)	ABS warning lamp ON	ON	BRC-119, "Inspection 25 ABS Warning Lamp Does Not Come On When Ignition Switch Is Turned On"
		ABS warning lamp OFF	OFF	
MOTOR RELAY	Operation status of motor and motor relay	Ignition switch ON or engine running (ABS not operated)	OFF	BRC-101, "Inspection 7 Actuator Motor, Motor Relay, and Circuit"
		Ignition switch ON or engine running (ABS operated)	ON	
ACTUATOR RLY	Actuator relay operation status	Vehicle stopped (Ignition switch ON)	OFF	BRC-101, "Inspection 7 Actuator Motor, Motor Relay, and Circuit"
		Vehicle stopped (Engine running)	ON	
OFF LAMP	VDC OFF indicator lamp status (Note 3)	When VDC OFF indicator lamp is ON	ON	BRC-115, "Inspection 20 VDC OFF Indicator Lamp Does Not Come On When Ignition Switch Is Turned On"
		When VDC OFF indicator lamp is OFF	OFF	
SLIP LAMP	SLIP indicator lamp status (Note 4)	When SLIP indicator lamp is ON	ON	BRC-113, "Inspection 19 SLIP Indicator Lamp Does Not Come On When Ignition Switch is Turned On"
		When SLIP indicator lamp is OFF	OFF	
FR LH IN SOL FR LH OUT SOL FR RH IN SOL FR RH OUT SOL RR RH IN SOL RR RH OUT SOL RR LH IN SOL RR LH OUT SOL	Solenoid valve operation	Actuator (solenoid) is active ("ACTIVE TEST" with CONSULT-II) or actuator relay is inactive (in fail-safe mode).	ON	BRC-99, "Inspection 6 Solenoid, VDC Switching Valve, Actuator Relay and Circuits"
		When actuator (solenoid) is not active and actuator relay is active (ignition switch ON).	OFF	
CV1 CV2 SV1 SV2	VDC/TCS switch-over valve status	When actuator (switch-over valve) is active ("ACTIVE TEST" with CONSULT-II) or actuator relay is inactive (when in fail-safe mode).	ON	BRC-99, "Inspection 6 Solenoid, VDC Switching Valve, Actuator Relay and Circuits"
		When actuator (switch-over valve) is not active and actuator relay is active (ignition switch ON).	OFF	
DECCEL G-SEN	Longitudinal acceleration detected by Decel G-Sensor	Vehicle stopped	-0.08 to 0.08G	BRC-98, "Inspection 5 Yaw Rate/Side/Decel G Sensor and Circuit Between Yaw Rate/Side/Decel G Sensor and ABS Actuator and Electric Unit (Control Unit)"
		Vehicle running	-1.7 to 1.7G	

TROUBLE DIAGNOSIS

[VDC/TCS/ABS]

Monitor item	Display content	Data monitor		Note: Error inspection checklist
		Condition	Reference value in normal operation	
2WD/4WD SEL	4WD ON/OFF condition	2WD mode	2WD	4WD switch and circuit
		4WD mode	4WD	
FLUID LEV SW	ON/OFF status of brake fluid level switch	When brake fluid level switch ON	ON	BRC-105, "Inspection 11 Brake Fluid Level in Reservoir Tank, Communication Circuit Between ABS Actuator and Electric Unit (Control Unit) and Brake Fluid Level Switch"
		When brake fluid level switch OFF	OFF	
VDC FAIL SIG TCS FAIL SIG ABS FAIL SIG EBD FAIL SIG	Fail signal status	VDC fail TCS fail ABS fail EBD fail	ON	VDC system TCS system ABS system EBD system
		Normal	OFF	—

Note 1: Confirm tire pressure is normal.

Note 2: ON/OFF timing of ABS warning lamp

ON: For approximately 2 seconds after ignition switch is turned ON, or when a malfunction is detected.

OFF: Approximately 2 seconds after ignition switch is turned ON (when system is in normal operation) and VDC/TCS function is not activated.

Note 3: ON/OFF timing of VDC OFF indicator lamp

ON: For approximately 2 seconds after ignition switch is turned ON, or when a malfunction is detected and VDC OFF condition by VDC switch is ON.

OFF: Approximately 2 seconds after ignition switch is turned ON (when system is in normal operation).

Note 4: SLIP indicator lamp ON/OFF timing

ON: For approximately 2 seconds after ignition switch is turned ON, or when a malfunction is detected and VDC/TCS function is activated while driving.

OFF: Approximately 2 seconds after ignition switch is turned ON (when system is in normal operation) and VDC/TCS function is not activated.

Blinking: VDC/TCS function is active during driving

A
B
C
D
E
BRC
G
H
I
J
K
L
M

TROUBLE DIAGNOSIS

[VDC/TCS/ABS]

EFS00314

CONSULT-II Functions CONSULT-II FUNCTION APPLICATION TABLE

CAUTION:

“FUNCTION TEST” shall not be used for diagnosis. For details, refer to separately supplied “CONSULT-II Instruction Manual (FUNCTION TEST)”.

Item	Self-diagnosis	Data monitor	Active test
Wheel sensors	×	×	–
Stop lamp switch	×	×	–
Solenoid valves	×	×	×
Switch-over solenoid valves	×	×	–
Yaw rate/side/decel G sensor	×	×	–
Pressure sensor	×	×	–
Steering angle sensor	×	×	–
Actuator relay	×	×	–
Motor relay	×	×	–
ABS warning lamp	–	×	–
Battery voltage	×	×	–
ABS actuator and electric unit (control unit)	×	–	–
VDC/TCS/ABS actuator motor	×	×	×
CAN communication	×	–	–
Engine speed signal	×	×	–
VDC OFF switch	–	×	–
VDC OFF indicator lamp	–	×	–
SLIP indicator lamp	–	×	–
Throttle angle	–	×	–
Gear	–	×	–
Selector lever position	–	×	–
4WD switch	×	×	–
CAN-LAN converter voltage supply	×	×	–
EBD/ABS/TCS/VDC signals	×	×	–
Brake fluid level switch	×	×	–

×:Applicable

–:Not applicable

CONSULT-II BASIC OPERATION PROCEDURE

1. Turn ignition switch OFF.
2. Connect CONSULT-II and CONSULT-II CONVERTER to the data link connector.

CAUTION:

If CONSULT-II is used with no connection of CONSULT-II CONVERTER, malfunctions might be detected in self-diagnosis depending on control unit which carry out CAN communication.

3. Turn ignition switch ON.

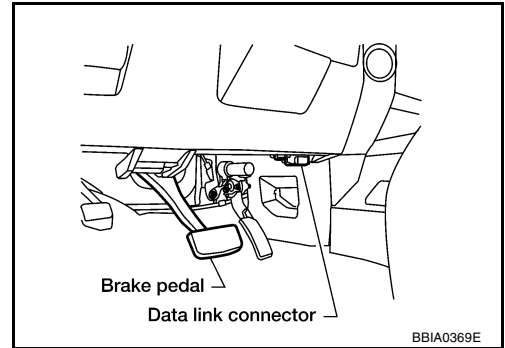

4. Touch "START (NISSAN BASED VHCL)".

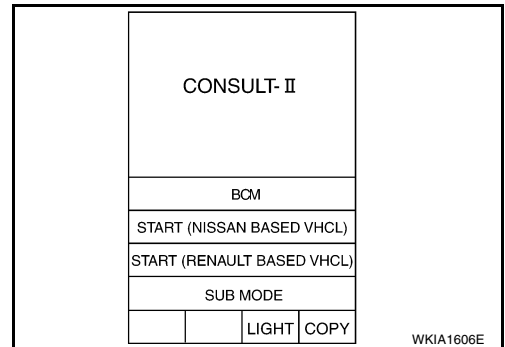

5. Touch "ABS" in the "Diagnosis System Selection" screen.
If "ABS" is not indicated, go to [GI-35, "CONSULT-II CHECKING SYSTEM"](#).

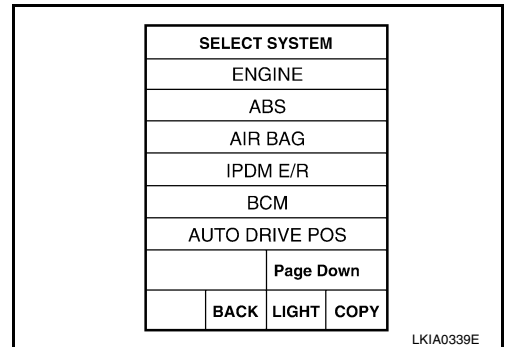

6. Select the required diagnostic location from the "Diagnosis Mode Selection" screen.
For further information, see the CONSULT-II Operation Manual.

SELF-DIAGNOSIS

Description

If a malfunction is detected in system, ABS warning lamp, VDC OFF indicator lamp, and SLIP indicator lamp in combination meter turn ON. In this case, perform self-diagnosis as follows:

Operation Procedure

1. Perform [BRC-92, "Basic Inspection"](#) using information from customer.
2. After ignition switch is turned OFF, connect CONSULT-II to data link connector.

CAUTION:

If CONSULT-II is used with no connection of CONSULT-II CONVERTER, malfunctions might be detected in self-diagnosis depending on control unit which carry out CAN communication.

3. Start engine and drive at approximately 30 km/h (19 MPH) for approximately 1 minute.

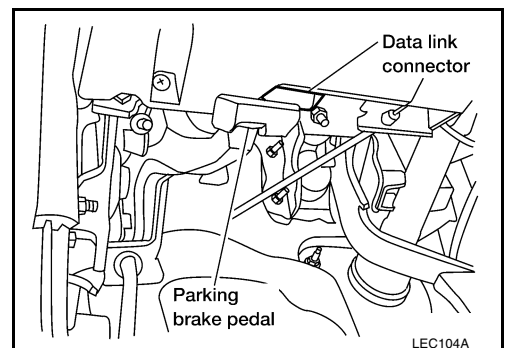

A
B
C
D
E
BRC
G
H
I
J
K
L
M

TROUBLE DIAGNOSIS

[VDC/TCS/ABS]

4. After stopping vehicle, with engine still idling, touch “START”, “ABS”, and “SELF-DIAG RESULTS” on CONSULT-II screen in this order.

CAUTION:
Just after starting engine, or turning ignition switch ON, “ABS” may not be displayed on system selection screen even if “START” is touched. In this case, start self-diagnosis again from step 2. If it cannot be shown after several attempts, ABS actuator and electric unit (control unit) may have malfunctioned. Replace ABS actuator and electric unit (control unit). Refer to [BRC-130, "ABS Actuator and Electric Unit"](#) .
5. Self-diagnosis result is displayed. (If necessary, touch “PRINT” to print self-diagnosis result.)
 - When “NO FAILURE” is shown, check ABS warning lamp, VDC OFF indicator lamp, SLIP indicator lamp. Refer to [BRC-90, "For Fast and Accurate Diagnosis"](#) .
 - CONSULT-II self-diagnosis results are displayed without regard to occurrence timing. In some cases later ones (timing value is small) appear on next screen.
6. Go to appropriate “Inspection” chart according to “Display Item List”, and repair or replace as necessary.
7. Start engine and drive at approximately 30 km/h (19 MPH) for approximately 1 minute.

CAUTION:
● Check again to make sure that there is no malfunction on other parts.
8. Turn ignition switch OFF to prepare for erasing memory.
9. Start engine and touch “START”, “ABS”, “SELF-DIAGNOSIS RESULTS”, and “ERASE MEMORY” on CONSULT-II screen in this order to erase memory.

CAUTION:
If memory cannot be erased, return to step 6.
10. Drive vehicle at approximately 30 km/h (19 MPH) and check that ABS warning lamp, VDC OFF indicator lamp, and SLIP indicator lamp stay off.

Self-Diagnostic Results Mode

Self-diagnostic item	Malfunction detecting condition	Check system
FR LH SENSOR- 1 [C1104]	Circuit of front LH wheel sensor is open, shorted or sensor power voltage is unusual	
RR RH SENSOR- 1 [C1101]	Circuit of rear RH wheel sensor is open, shorted or sensor power voltage is unusual	
FR RH SENSOR- 1 [C1103]	Circuit of front RH wheel sensor is open, shorted or sensor power voltage is unusual	
RR LH SENSOR- 1 [C1102]	Circuit of rear LH wheel sensor is open, shorted or sensor power voltage is unusual	
FR LH SENSOR- 2 [C1108]	ABS actuator and electric unit (control unit) cannot identify sensor pulses, because of large gap between wheel sensor and sensor rotor.	BRC-94, "Inspection 1 Wheel Sensor System" (Note 1)
RR RH SENSOR- 2 [C1105]	ABS actuator and electric unit (control unit) cannot identify sensor pulses, because of large gap between wheel sensor and sensor rotor.	
FR RH SENSOR- 2 [C1107]	ABS actuator and electric unit (control unit) cannot identify sensor pulses, because of large gap between wheel sensor and sensor rotor.	
RR LH SENSOR- 2 [C1106]	ABS actuator and electric unit (control unit) cannot identify sensor pulses, because of large gap between wheel sensor and sensor rotor.	
STOP LAMP SW [C1116]	Stop lamp switch circuit is open.	BRC-102, "Inspection 8 Stop Lamp Switch and Circuit"
PRESS SEN CIRCUIT [C1142]	Pressure sensor signal line is open or shorted, or pressure sensor is malfunctioning.	BRC-96, "Inspection 3 Pressure Sensor and Circuit Between Pressure Sensor and ABS Actuator and Electric Unit (Control Unit)"

TROUBLE DIAGNOSIS

[VDC/TCS/ABS]

Self-diagnostic item	Malfunction detecting condition	Check system	
ST ANGLE SEN CIRCUIT [C1143]	Neutral position of steering angle sensor is dislocated, or steering angle sensor is malfunctioning.	BRC-97. "Inspection 4 Steering Angle Sensor and Circuit Between Steering Angle Sensor and ABS Actuator and Electric Unit (Control Unit)"	
YAW RATE SENSOR [C1145]	Yaw rate sensor has generated an error, or yaw rate sensor signal line is open or shorted.	BRC-98. "Inspection 5 Yaw Rate/Side/Decel G Sensor and Circuit Between Yaw Rate/Side/Decel G Sensor and ABS Actuator and Electric Unit (Control Unit)"	
DECEL G SENSOR [C1113]	Decel G sensor is malfunctioning or signal line of decel G sensor is open or shorted.	BRC-121. "Inspection 26 When "DECEL G-SENSOR" Appears on Self-Diagnosis Results Display"	
ACTUATOR RLY [C1140]	Actuator solenoid valve relay is ON, even if control unit sends OFF signal.	BRC-101. "Inspection 7 Actuator Motor, Motor Relay, and Circuit"	
	Actuator solenoid valve relay is OFF, even if control unit sends ON signal.		
FR LH IN ABS SOL [C1120]	Circuit of front LH IN ABS solenoid is open or shorted, or control line is open or shorted to power supply or ground.	BRC-99. "Inspection 6 Solenoid, VDC Switching Valve, Actuator Relay and Circuits"	
FR LH OUT ABS SOL [C1121]	Circuit of front LH OUT ABS solenoid is open or shorted, or control line is open or shorted to power supply or ground.		
RR RH IN ABS SOL [C1126]	Circuit of rear RH IN ABS solenoid is open or shorted, or control line is open or shorted to power supply or ground.		
RR RH OUT ABS SOL [C1127]	Circuit of rear RH OUT ABS solenoid is open or shorted, or control line is open or shorted to power supply or ground.		
FR RH IN ABS SOL [C1122]	Circuit of front RH IN ABS solenoid is open or shorted, or control line is open or shorted to power supply or ground.		
FR RH OUT ABS SOL [C1123]	Circuit of front RH OUT ABS solenoid is open or shorted, or control line is open or shorted to power supply or ground.		
RR LH IN ABS SOL [C1124]	Circuit of rear LH IN ABS solenoid is open or shorted, or control line is open or shorted to power supply or ground.		
RR LH OUT ABS SOL [C1125]	Circuit of rear LH OUT ABS solenoid is open or shorted, or control line is open or shorted to power supply or ground.		
CV1 [C1164]	Front side VDC switch-over solenoid valve (cut valve 1) is open or shorted, or control line is open or shorted to power supply or ground.		
CV2 [C1165]	Rear side VDC switch-over solenoid valve (cut valve 2) is open or shorted, or control line is open or shorted to power supply or ground.		
SV1 [C1166]	Front side VDC switch-over solenoid valve (suction valve 1) is open or shorted, or control line is open or shorted to power supply or ground.		
SV2 [C1167]	Rear side VDC switch-over solenoid valve (suction valve 2) is open or shorted, or control line is open or shorted to power supply or ground.		
PUMP MOTOR (Note 3) [C1111]	During actuator motor operation with ON, when actuator motor turns OFF or when control line for actuator motor relay is open.		BRC-101. "Inspection 7 Actuator Motor, Motor Relay, and Circuit"
	During actuator motor operation with OFF, when actuator motor turns ON or when control line for relay is shorted to ground.		

A
B
C
D
E
G
H
I
J
K
L
M

BRC

TROUBLE DIAGNOSIS

[VDC/TCS/ABS]

Self-diagnostic item	Malfunction detecting condition	Check system
ABS SENSOR [ABNORMAL SIGNAL] [C1115]	Wheel sensor input is abnormal.	BRC-94, "Inspection 1 Wheel Sensor System" (Note 1)
BATTERY VOLTAGE [ABNORMAL] [C1109]	ABS actuator and electric unit (control unit) power voltage is too low.	BRC-103, "Inspection 9 ABS Actuator and Electric Unit (Control Unit) Power Supply and Ground Circuit"
ST ANGLE SEN SIGNAL [C1144]	Neutral position correction of steering angle sensor is not finished.	BRC-97, "Inspection 4 Steering Angle Sensor and Circuit Between Steering Angle Sensor and ABS Actuator and Electric Unit (Control Unit)"
ST ANG SEN COM CIR [C1156]	CAN communication line or steering angle sensor has generated an error.	
SIDE G-SEN CIRCUIT [C1146]	Side G-sensor is malfunctioning, or signal line of side G-sensor is open or shorted.	BRC-98, "Inspection 5 Yaw Rate/Side/Decel G Sensor and Circuit Between Yaw Rate/Side/Decel G Sensor and ABS Actuator and Electric Unit (Control Unit)"
CONTROLLER FAILURE [C1110]	Internal malfunction of ABS actuator and electric unit (control unit)	BRC-95, "Inspection 2 ABS Actuator and Electric Unit (Control Unit) System"
CAN COMM CIRCUIT [U1000]	<ul style="list-style-type: none"> ● CAN communication line is open or shorted. ● ABS actuator and electric unit (control unit) internal malfunction ● Battery voltage for ECM is suddenly interrupted for approximately 0.5 seconds or more. 	BRC-106, "Inspection 12 CAN Communications Lines, ABS Actuator and Electric Unit (Control Unit), Steering Angle Sensor System and CAN-LAN Converter ECU (CLC)" (Note 2)
BR FLUID LEVEL LOW [C1155]	Brake fluid level drops or circuit between ABS actuator and electric unit (control unit) and brake fluid level switch is open or shorted.	BRC-105, "Inspection 11 Brake Fluid Level in Reservoir Tank, Communication Circuit Between ABS Actuator and Electric Unit (Control Unit) and Brake Fluid Level Switch"
ENGINE SPEED SIG [C1168]	Engine speed signal from ECM is abnormal.	BRC-108, "Inspection 14 ENG SPEED SIG - Engine Speed Signal"
LAN COMM 1 [C1169]	The communication line between CAN-LAN converter (CLC) and ECM is open or shorted.	BRC-110, "Inspection 15 ENG CHECK SIG - LAN Monitoring"
LAN SIGNAL 2 [C1172]	On the local area network (LAN) between CLC and ECM, ECM does not transmit the LAN start signal to CLC.	BRC-111, "Inspection 16 LAN SIGNAL 2 - LAN Communication Start Procedure Incomplete"
LAN SIGNAL 3 [C1173]	The communication start signal output is not terminated and the ordinary signals are not entered to CLC.	BRC-113, "Inspection 18 LAN SIGNAL 3 - Continued Reception After LAN Communication Starts"
ENGINE SIGNAL 1 [C1130]	Based on the signal from ECM, the CLC judges that the engine control system is malfunctioning.	BRC-107, "Inspection 13 ENGINE SIGNAL 1 - Engine System"

TROUBLE DIAGNOSIS

[VDC/TCS/ABS]

Self-diagnostic item	Malfunction detecting condition	Check system
ENGINE CHECK SIG [C1171]	ECM judges the communication between VDC control unit or CLC and ECM is abnormal.	BRC-112, "Inspection 17. LAN COMM 1 - LAN Communication System Failure"
CAN COMM 1 [C1174]	CLC judges the CAN communication line between VDC control unit and CLC is open or shorted.	BRC-119, "Inspection 23. CAN CIRCUIT 1 - CAN Communication System Failure"
CLC CONTROL UNIT [C1175]	Function of calculation in CLC has failed.	BRC-117, "Inspection 22. CAN-LAN Converter Power Supply Circuit"
CLC BATTERY VOLT [C1177]	Power source voltage supplied to CLC is abnormally low.	
VARIANT CODING [C1170]	V coding is not functioning.	The ABS actuator and electric unit (control unit) and circuit

A
B
C
D
E
G
H
I
J
K
L
M

BRC

Note 1. If wheel sensor 2 for each wheel is indicated, check ABS actuator and electric unit (control unit) power supply voltage in addition to wheel sensor circuit check.

Note 2. If multiple malfunctions are detected including CAN communication line [U1000], perform diagnosis for CAN communication line first.

Note 3: "ACTUATOR RLY" on the CONSULT-II self-diagnosis results indicates the malfunction of the actuator motor relay or circuit.

DATA MONITOR

- For details of data monitor function, refer to "CONSULT-II Instruction Manual".

Operation Procedure

- Turn ignition switch OFF.
- Connect CONSULT-II to data link connector.

CAUTION:

If CONSULT-II is used with no connection of CONSULT-II CONVERTER, malfunctions might be detected in self-diagnosis depending on control unit which carry out CAN communication.

- Turn ignition switch ON.
- Touch "START" on display.

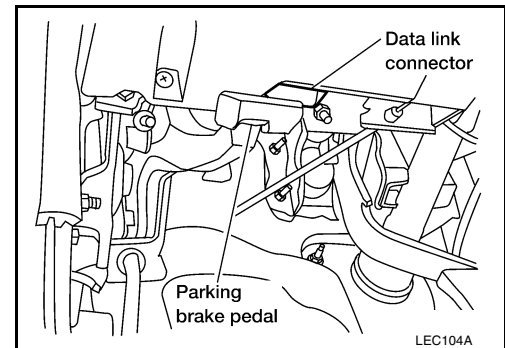

- Touch "ABS" on display.

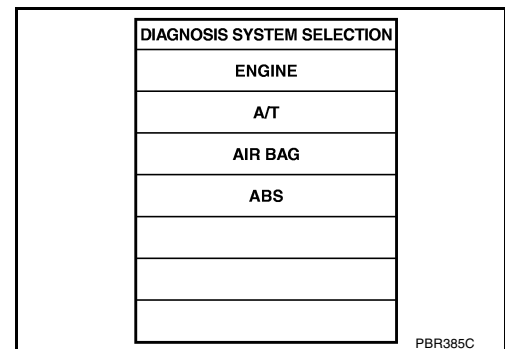

- Touch "DATA MONITOR".

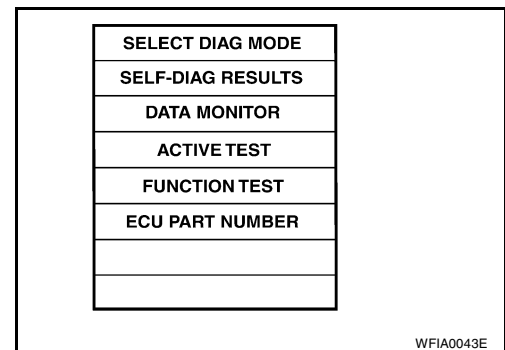

- Return to monitor item selection screen and touch any of "ECU INPUT SIGNALS", "MAIN SIGNALS", "CAN DIAG SUPPORT MNTR" or "SELECTION FROM MENU". Refer to [BRC-85, "Display Item List"](#).

- Touch "START".
- Screen of data monitor is displayed.

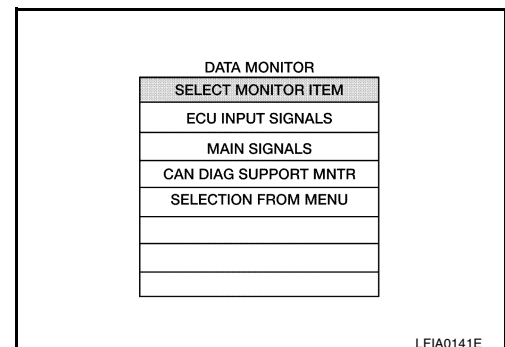

TROUBLE DIAGNOSIS

[VDC/TCS/ABS]

Display Item List

Item (Unit)	Data monitor item selection				Remarks
	ECU INPUT SIGNALS	MAIN SIGNALS	SELECTION FROM MENU	CAN DIAG SUPPORT MNTR	
GEAR	×	×	×	-	Gear position judged by TCM signal is displayed.
FR RH SENSOR (km/h, MPH)	×	×	×	-	Wheel speed calculated by front RH wheel sensor signal is displayed.
FR LH SENSOR (km/h, MPH)	×	×	×	-	Wheel speed calculated by front LH wheel sensor signal is displayed.
RR RH SENSOR (km/h, MPH)	×	×	×	-	Wheel speed calculated by rear RH wheel sensor signal is displayed.
RR LH SENSOR (km/h, MPH)	×	×	×	-	Wheel speed calculated by rear LH wheel sensor signal is displayed.
BATTERY VOLT (V)	×	×	×	-	Voltage supplied to ABS actuator and electric unit (control unit) is displayed.
SLCT LVR POSI	×	×	×	-	Shift position judged by PNP, reverse switch signal.
ACCEL POS SIG (%)	×	-	×	-	Throttle valve open/close status judged by ECM signal is displayed.
ENGINE SPEED (rpm)	×	×	×	-	Engine speed judged by ECM signal is displayed.
STR ANGLE SIG (deg)	×	-	×	-	Steering angle detected by steering angle sensor is displayed.
YAW RATE SEN (d/s)	×	×	×	-	Yaw rate detected by yaw rate sensor is displayed.
DECEL G SEN (G)	×	×	×	-	Longitudinal acceleration detected by decel G sensor is displayed.
SIDE G-SENSOR (m/s ²)	×	-	×	-	Transverse acceleration detected by side G-sensor is displayed.
PRESS SENSOR (bar)	×	-	×	-	Brake fluid pressure detected by pressure sensor is displayed.
STOP LAMP SW (ON/OFF)	×	×	×	-	Stop lamp switch (ON/OFF) status is displayed.
OFF SW (ON/OFF)	×	×	×	-	VDC OFF switch (ON/OFF) status is displayed.
ABS WARN LAMP (ON/OFF)	-	×	×	-	ABS warning lamp (ON/OFF) status is displayed.
SLIP LAMP (ON/OFF)	-	×	×	-	SLIP indicator lamp (ON/OFF) status is displayed.
FR LH IN SOL (ON/OFF)	-	×	×	-	Front LH IN ABS solenoid (ON/OFF) status is displayed.
FR LH OUT SOL (ON/OFF)	-	×	×	-	Front LH OUT ABS solenoid (ON/OFF) status is displayed.

A
B
C
D
E
BRC
G
H
I
J
K
L
M

TROUBLE DIAGNOSIS

[VDC/TCS/ABS]

Item (Unit)	Data monitor item selection				Remarks
	ECU INPUT SIGNALS	MAIN SIGNALS	SELECTION FROM MENU	CAN DIAG SUPPORT MNTR	
RR RH IN SOL (ON/OFF)	-	×	×	-	Rear RH IN ABS solenoid (ON/OFF) status is displayed.
RR RH OUT SOL (ON/OFF)	-	×	×	-	Rear RH OUT ABS solenoid (ON/OFF) status is displayed.
FR RH IN SOL (ON/OFF)	-	×	×	-	Front RH IN ABS solenoid (ON/OFF) status is displayed.
FR RH OUT SOL (ON/OFF)	-	×	×	-	Front RH OUT ABS solenoid (ON/OFF) status is displayed.
RR LH IN SOL (ON/OFF)	-	×	×	-	Rear LH IN ABS solenoid (ON/OFF) status is displayed.
RR LH OUT SOL (ON/OFF)	-	×	×	-	Rear LH OUT ABS solenoid (ON/OFF) status is displayed.
OFF LAMP (ON/OFF)	-	×	×	-	OFF Lamp (ON/OFF) status is displayed.
MOTOR RELAY (ON/OFF)	-	×	×	-	ABS motor relay signal (ON/ OFF) status is displayed.
ACTUATOR RLY (ON/OFF)	-	×	×	-	ABS actuator relay signal (ON/OFF) status is displayed.
CV1 (ON/OFF)	-	-	×	-	Front side switch-over sole- noid valve (cut valve 1) (ON/ OFF) status is displayed.
CV2 (ON/OFF)	-	-	×	-	Rear side switch-over sole- noid valve (cut valve 2) (ON/ OFF) status is displayed.
SV1 (ON/OFF)	-	-	×	-	Front side switch-over sole- noid valve (suction valve 1) (ON/OFF) status is displayed.
SV2 (ON/OFF)	-	-	×	-	Rear side switch-over sole- noid valve (suction valve 2) (ON/OFF) status is displayed.
VDC FAIL SIG (ON/OFF)	-	-	×	-	VDC fail signal (ON/OFF) sta- tus is displayed.
TCS FAIL SIG (ON/OFF)	-	-	×	-	TCS fail signal (ON/OFF) sta- tus is displayed.
ABS FAIL SIG (ON/OFF)	-	-	×	-	ABS fail signal (ON/OFF) sta- tus is displayed.
EBD FAIL SIG (ON/OFF)	-	-	×	-	EBD fail signal (ON/OFF) sta- tus is displayed.
FLUID LEV SW (ON/OFF)	×	-	×	-	Brake fluid level switch (ON/ OFF) status is displayed.
EBD SIGNAL (ON/OFF)	-	-	×	-	EBD operation (ON/OFF) sta- tus is displayed.
ABS SIGNAL (ON/OFF)	-	-	×	-	ABS operation (ON/OFF) sta- tus is displayed.
TCS SIGNAL (ON/OFF)	-	-	×	-	TCS operation (ON/OFF) sta- tus is displayed.
VDC SIGNAL (ON/OFF)	-	-	×	-	VDC operation (ON/OFF) sta- tus is displayed.
CAN COMM (OK/NG)	-	-	-	×	CAN communication signal (OK/NG) status is displayed.

TROUBLE DIAGNOSIS

[VDC/TCS/ABS]

Item (Unit)	Data monitor item selection				Remarks
	ECU INPUT SIGNALS	MAIN SIGNALS	SELECTION FROM MENU	CAN DIAG SUPPORT MNTR	
CAN CIRC 1 (OK/UNKWN)	-	-	-	×	CAN communication signal (OK/UNKWN) status is displayed.
CAN CIRC 2 (OK/UNKWN)	-	-	-	×	
CAN CIRC 3 (OK/UNKWN)	-	-	-	×	
CAN CIRC 4 (OK/UNKWN)	-	-	-	×	
CAN CIRC 5 (OK/UNKWN)	-	-	-	×	
CAN CIRC 6 (OK/UNKWN)	-	-	-	×	
CAN CIRC 7 (OK/UNKWN)	-	-	-	×	
CAN CIRC CLC (OK/UNKWN)	-	-	-	×	
TRQ MAP S/C	-	-	×	-	S/C is selected for engine torque map
TRQ MAP N/A	-	-	×	-	N/A is selected for engine
2WD/4WD SEL	-	-	×	-	Distinguish 2WD and 4WD
CLC VOLT (V)	-	-	×	-	Voltage supplied to CAN-LAN converter is displayed

×:Applicable

-:Not applicable

ACTIVE TEST

Operation Procedure

CAUTION:

- Do not perform active test while driving the vehicle.
- Make sure to completely bleed air from brake system.
- Active test cannot be performed when ABS warning lamp is on.

1. Connect the CONSULT-II connector to the data link connector and start the engine.

CAUTION:

If CONSULT-II is used with no connection of CONSULT-II CONVERTER, malfunctions might be detected in self-diagnosis depending on control unit which carry out CAN communication.

2. Touch "START" on the display.
3. Touch "ABS" and "ACTIVE TEST".

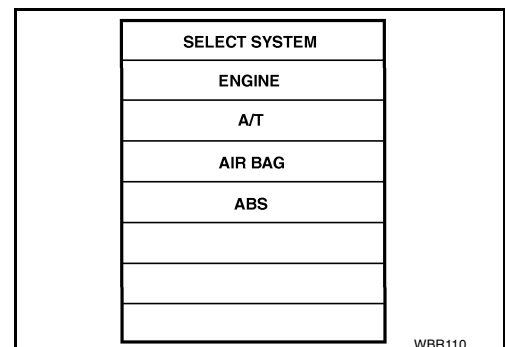

4. Test item selection screen is displayed.
5. Touch necessary test item.

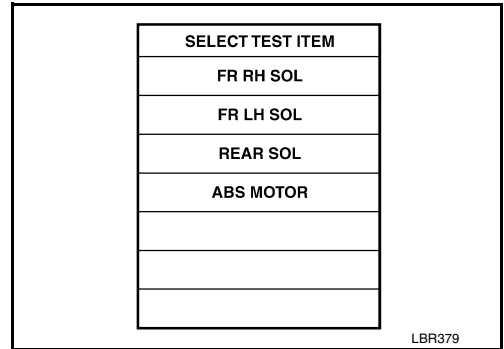
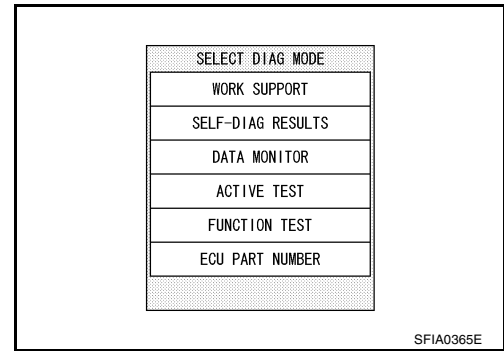

6. Touch "START" with "MAIN SIGNALS" line inverted.
7. Carry out active test by touching screen key.

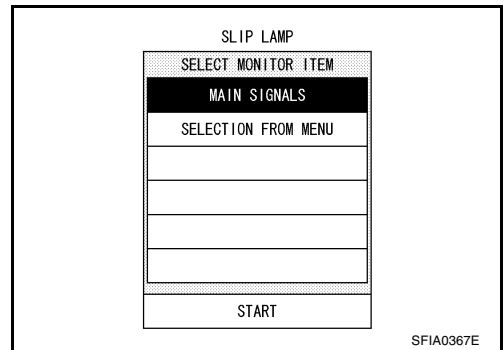

Solenoid Valve

1. To perform active test of ABS functions, select major items for each test item. To perform active test of VDC/TCS functions, select item menu for each test item.
2. For ABS solenoid valve, touch "UP", "KEEP" and "DOWN". For ABS solenoid valve (ACT), touch "UP," "ACTUATOR UP" and "ACTUATOR KEEP". Use screen monitor to check that solenoid valve operates as shown in Solenoid Valve Operation Chart. Refer to [BRC-88, "Solenoid Valve Operation Chart"](#) .

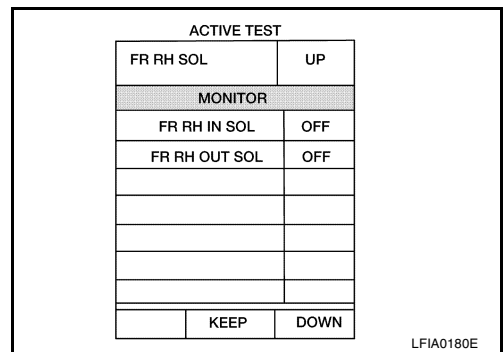

Solenoid Valve Operation Chart

Operation		ABS solenoid valve			ABS solenoid valve (ACT)		
		UP	KEEP	DOWN	UP	ACTUA-TOR UP	ACTUA-TOR KEEP
FR RH SOL FR RH ABS SOLE- NOID	FR RH IN SOL	OFF	ON	ON	OFF	OFF	ON
	FR RH OUT SOL	OFF	OFF	ON*	OFF	OFF	OFF
	CUT VALVE 1	OFF			OFF	ON	
	SUCTION VALVE 1	OFF			OFF	ON	

TROUBLE DIAGNOSIS

[VDC/TCS/ABS]

Operation		ABS solenoid valve			ABS solenoid valve (ACT)		
		UP	KEEP	DOWN	UP	ACTUA-TOR UP	ACTUA-TOR KEEP
FR LH SOL FR LH ABS SOLE- NOID	FR LH IN SOL	OFF	ON	ON	OFF	OFF	ON
	FR LH OUT SOL	OFF	OFF	ON*	OFF	OFF	OFF
	CUT VALVE 1	OFF			OFF	ON	
	SUCTION VALVE 1	OFF			OFF	ON	
RR RH SOL RR RH ABS SOLE- NOID	RR RH IN SOL	OFF	ON	ON	OFF	OFF	ON
	RR RH OUT SOL	OFF	OFF	ON*	OFF	OFF	OFF
	CUT VALVE 2	OFF			OFF	ON	
	SUCTION VALVE 2	OFF			OFF	ON	
RR LH SOL RR LH ABS SOLE- NOID	RR LH IN SOL	OFF	ON	ON	OFF	OFF	ON
	RR LH OUT SOL	OFF	OFF	ON*	OFF	OFF	OFF
	CUT VALVE 2	OFF			OFF	ON	
	SUCTION VALVE 2	OFF			OFF	ON	

*: ON for 1 to 2 seconds after the touch, and then OFF

NOTE:

- If active test is performed with brake pedal depressed, pedal stroke may change. This is normal.
- “TEST IS STOPPED” is displayed approximately 10 seconds after operation starts.
- After “TEST IS STOPPED” is displayed, to perform test again, repeat Step 6.

ABS Motor

Touch “ON” and “OFF” on the screen. Check that ABS motor relay operates as shown in table below.

Operation	ON	OFF
ABS actuator relay	ON	ON
ABS motor relay	ON	OFF

NOTE:

- If active test is performed with brake pedal depressed, pedal stroke may change. This is normal.
- “TEST IS STOPPED” is displayed approximately 10 seconds after operation starts.

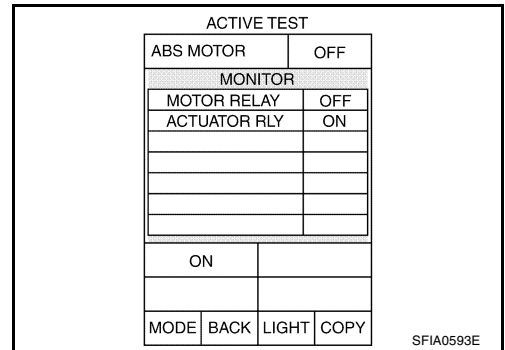

For Fast and Accurate Diagnosis

PRECAUTIONS FOR DIAGNOSIS

- Before performing diagnosis, always read precautions. Refer to [BRC-52, "PRECAUTIONS"](#) .
- If ABS actuator and electric unit (control unit), steering angle sensor, steering system parts, suspension system parts, or tires have been replaced, or if alignment has been adjusted, be sure to adjust neutral position of steering angle sensor before driving. Refer to [BRC-55, "Adjustment of Steering Angle Sensor Neutral Position"](#) .
- When replacing ABS actuator and electric unit (control unit), be sure labels on control units are the same part number.
- After diagnosis is finished, be sure to erase memory. Refer to [BRC-79, "Operation Procedure"](#) .
- When checking continuity and voltage between units, be sure to check for disconnection, looseness, bend, or collapse of connector terminals. If any non-standard condition is found, repair or replace connector terminals.
- For intermittent symptoms, possible cause is malfunction in harness, harness connector, or terminals. Move harness, harness connector, and terminals to check for poor connections.
- If a circuit tester is used for the check, be careful not to forcibly extend any connector terminal.
- To use CONSULT-II to perform self-diagnosis of ABS actuator and electric unit (control unit), active tests, or work support, first stop work, then connect CONSULT-II and select "ABS".
- CONSULT-II self-diagnosis results are displayed without regard to occurrence timing. In some cases later ones (timing value is small) appear on the next screen.
- While self-diagnosis results of CONSULT-II shows an error, if CONSULT-II active test is performed, an engine system error may be indicated. In this case, start engine to resume the normal screen.
- VDC/TCS/ABS system electronically controls brake operation and engine output. The following symptoms may be caused by normal operations:

Symptom	Symptom description	Result
Motor operation noise	This is noise of motor inside VDC/TCS/ABS actuator. Slight noise may occur during VDC, TCS, and ABS operation.	Normal
	When the vehicle speed goes over 20 km/h (12.5 mph), the motor and valves operating noise may be heard. It happens only once after IGN (ignition) is ON. This is a normal status of the system operation check.	
System operation check noise	When the engine starts, slight "click" noise may be heard from engine compartment. This is normal and is part of system operation check.	Normal
VDC/TCS operation (SLIP lamp blinking)	TCS may activate momentarily if wheel speed changes when driving over location where friction coefficient varies, when downshifting / upshifting, or when fully depressing accelerator pedal.	Normal Cancel the VDC/TCS function for the inspection on a chassis dynamometer.
	For inspection of speedometer or other instruments, press VDC OFF SW to turn VDC/TCS function off. When accelerator pedal is depressed on a chassis dynamometer (fixed front-wheel type), vehicle speed will not increase. This is not normal. It is result of TCS being activated by stationary front wheels. Warning lamp may also illuminate to indicate "sensor system error". This is also normal, and is the result of the stationary front wheels being detected. To be certain, restart engine, and drive vehicle at 30 km/h or above. Check that warning lamp does not illuminate.	
ABS operation (Longer stopping distance)	On roads with low friction coefficients, such as snowy roads or gravel roads, vehicles with ABS may require a longer stopping distance. Therefore, when driving on such roads, avoid overconfidence and keep speed sufficiently low.	Normal
Insufficient feeling of acceleration	Depending on road conditions, driver may feel that feeling of acceleration is insufficient. This is because traction control, which controls the engine and brakes to achieve optimal traction, has the highest priority (for safety). As a result, there may be times when acceleration is slightly less than usual for the same accelerator pedal operation.	Normal

TROUBLE DIAGNOSIS

[VDC/TCS/ABS]

ON and OFF Timing for ABS Warning Lamp, VDC OFF Indicator Lamp, and SLIP Indicator Lamp

x: ON -: OFF

Condition	ABS warning lamp	VDC OFF indicator lamp	SLIP indicator lamp	Remarks
Ignition SW OFF	-	-	-	—
For approx. 2 seconds after ignition SW is turned ON	x	x	x	—
Approx. 2 seconds after ignition switch ON	-	-	-	Turns OFF 2 seconds after ignition switch ON.
VDC OFF SW is turned ON. (VDC/TCS function is OFF.)	-	x	-	—
There is an VDC/TCS/ABS error.	x	x	x	—
	x	x	x	There is an ABS actuator and electric unit (control unit) or system error. (Power or ground malfunction)
When VDC/TCS is not functioning normally.	-	x	x	—

A
B
C
D
E
BRC
G
H
I
J
K
L
M

Basic Inspection

BASIC INSPECTION 1: BRAKE FLUID LEVEL AND LEAK INSPECTION

1. Check fluid level in the brake reservoir tank. If fluid level is low, refill the brake fluid.
2. Check for leakage in brake piping and around VDC/TCS/ABS actuator. If leakage or seepage is found, check as follows.
 - If ABS actuator and electric unit (control unit) connector is loose, tighten piping to specified torque. Then inspect again and confirm that there is no leakage.
 - If connection of flare nuts or screws of VDC/TCS/ABS actuator are damaged, replace damaged parts. Then inspect again and confirm that there is no leakage.
 - If there is leakage or seepage at any location other than VDC/TCS/ABS actuator connections, wipe away leakage or seepage with clean cloth. Then inspect again and confirm that there is no leakage.
 - If there is leakage from VDC/TCS/ABS actuator, wipe away leakage or seepage with clean cloth. Then inspect again. If there is leakage or seepage, replace VDC/TCS/ABS actuator unit.

CAUTION:

ABS actuator body cannot be disassembled.

3. Check brake disc rotor and pads and brake drum and linings. Refer to [MA-42, "Checking Disc Brake"](#) and [MA-42, "Checking Drum Brake"](#).

BASIC INSPECTION 2: INSPECTION FOR LOOSENESS OF POWER SYSTEM TERMINALS

Check cables for looseness on the battery positive/negative terminals and ground connection. If looseness is detected, tighten the cables to the specified torque. Check that the battery voltage does not drop and the generator is normal.

BASIC INSPECTION 3: INSPECTION OF ABS WARNING LAMP, VDC OFF INDICATOR LAMP, AND SLIP INDICATOR LAMP

1. Check that ABS warning lamp illuminates for approximately 2 seconds when ignition switch is turned ON. If it does not illuminate, inspect ABS warning lamp and circuit, and inspect combination meter. Refer to [BRC-66, "Wiring Diagram — VDC —"](#).
2. Check that VDC OFF indicator lamp illuminates for approximately 2 seconds when ignition switch is turned ON. If it does not illuminate, inspect VDC OFF indicator lamp and circuit, and inspect combination meter. Refer to [BRC-66, "Wiring Diagram — VDC —"](#).
3. Check that SLIP indicator lamp illuminates for approximately 2 seconds when ignition switch is turned ON. If it does not turn on, check SLIP indicator lamp and circuit and combination meter. Refer to [BRC-66, "Wiring Diagram — VDC —"](#).
4. With engine running, turn VDC OFF switch ON and OFF. Check that VDC OFF indicator lamp turns ON and OFF. If indicator lamp does not turn ON and OFF according to switch operation, inspect VDC OFF switch and circuit and combination meter. Refer to [BRC-66, "Wiring Diagram — VDC —"](#).

Symptom Chart

Symptom	Malfunctioning part	Reference page
ABS works frequently	—	BRC-122
Unexpected pedal reaction	—	BRC-122
Long stopping distance	—	BRC-123
ABS does not work	—	BRC-123
Pedal vibration and noise	—	BRC-124
ABS indicator lamp does not come on when ignition switch is turned ON	<ul style="list-style-type: none"> ● Fuse ● Combination meter ● Circuit(s) ● ABS actuator and electric unit (control unit) 	BRC-119
SLIP indicator lamp does not come on when ignition switch is turned ON	<ul style="list-style-type: none"> ● Fuse ● Combination meter ● Circuit(s) ● ABS actuator and electric unit (control unit) 	BRC-113

TROUBLE DIAGNOSIS

[VDC/TCS/ABS]

Symptom	Malfunctioning part	Reference page
VDC OFF indicator lamp does not come on when ignition switch is turned ON	<ul style="list-style-type: none"> ● Fuse ● Combination meter ● Circuit(s) ● ABS actuator and electric unit (control unit) 	BRC-115
Vehicle behaves jerkily during VDC/TCS/ABS operation	—	BRC-125

A

B

C

D

E

BRC

G

H

I

J

K

L

M

Inspection 1 Wheel Sensor System**INSPECTION PROCEDURE****DTC C1101, C1102, C1103, C1104, C1105, C1106, C1107, C1108 or C1115**

First use CONSULT-II self-diagnosis results to determine positions of malfunctioning wheel sensors. Then inspect parts and determine which parts to replace.

1. CONNECTOR INSPECTION

1. Disconnect the ABS actuator and electric unit (control unit) connector E39 and wheel sensor of malfunction code. Check the terminals for deformation, disconnection, looseness or damage.

OK or NG

OK >> GO TO 2.

NG >> Repair or replace as necessary.

2. CHECK WHEEL SENSOR OUTPUT SIGNAL

1. Disconnect connector from wheel sensor of malfunction code No.
2. Connect ABS active wheel sensor tester (J-45741) to wheel sensor using appropriate adapter.
3. Turn on the ABS active wheel sensor tester power switch.

NOTE:

The green POWER indicator should illuminate. If the POWER indicator does not illuminate, replace the battery in the ABS active wheel sensor tester before proceeding.

4. Spin the wheel of the vehicle by hand and observe the red SENSOR indicator on the ABS active wheel sensor tester. The red SENSOR indicator should flash on and off to indicate an output signal.

NOTE:

If the red SENSOR indicator illuminates but does not flash, reverse the polarity of the tester leads and retest.

Does the ABS active wheel sensor tester detect a signal?

Yes >> GO TO 3.

No >> GO TO 6.

3. CHECK TIRE

Check for inflation pressure, wear and size of each tire.

Are tire pressure and size correct and is tire wear within specifications?

Yes >> GO TO 4.

No >> Adjust tire pressure or replace tire(s).

4. CHECK WHEEL BEARINGS

Check wheel bearing axial end play. Refer to [FAX-5, "Front Wheel Bearing"](#) or [RAX-6, "Rear Wheel Bearing"](#).

Is axial end play within specifications?

Yes >> GO TO 5.

No >> Repair as necessary. Refer to [FAX-9, "WHEEL HUB AND KNUCKLE"](#) or [RAX-7, "WHEEL HUB"](#).
Then retest.

5. SENSOR ROTOR INSPECTION

Check for damage to sensor rotor teeth.

Is inspection result OK?

OK >> GO TO 6.

NG >> Replace sensor rotor. Refer to [BRC-128, "Front Sensor Rotor"](#) or [BRC-129, "Rear Sensor Rotor"](#)

6. CHECK WIRING HARNESS FOR SHORT CIRCUIT

1. Disconnect ABS actuator and electric unit (control unit) connector and wheel sensor connector of malfunction code No.
2. Check resistance between harness connector terminal and ground.

Continuity should not exist.

OK or NG?

- OK >> GO TO 7.
- NG >> Repair the circuit.

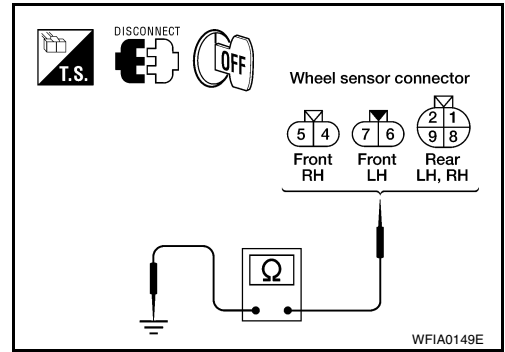

7. CHECK WIRING HARNESS FOR OPEN CIRCUIT

1. Disconnect ABS actuator and electric unit (control unit) connector and wheel sensor connector of malfunction code No.
2. Check continuity between both wiring harness ends.

Sensor	ABS actuator and electric unit (control unit)		Wheel sensor		Continuity
	Connector - terminal	Wire color	Connector - terminal	Wire color	
Front LH	E39 - 46	G	E16 - 6	G	Yes
	E39 - 45	R	E16 - 7	R	
Front RH	E39 - 34	P	E2 - 5	P	
	E39 - 33	L	E2 - 4	L	
Rear LH	E39 - 36	W	C6 - 9	W	
	E39 - 37	B	C6 - 8	B	
Rear RH	E39 - 42	LG	C6 - 1	LG	
	E39 - 43	PU	C6 - 2	PU	

Continuity should exist.

OK or NG?

- OK >> Replace the ABS actuator and electric unit (control unit). Refer to [BRC-130, "ABS Actuator and Electric Unit"](#).
- NG >> Repair the circuit.

Inspection 2 ABS Actuator and Electric Unit (Control Unit) System

EFS00319

DTC C1110

Inspection Procedure

1. CHECKING SELF-DIAGNOSIS RESULTS

Check self-diagnosis results.

Self-diagnosis results
CONSULT-II display items
CONTROLLER FAILURE

Does anything other than "CONTROLLER FAILURE" appear on self-diagnosis display?

- YES >> Repair or replace the items indicated. Then perform self-diagnosis again.
- NO >> Replace ABS actuator and electric unit (control unit). Refer to [BRC-130, "ABS Actuator and Electric Unit"](#). Then perform ABS actuator and electric unit (control unit) self-diagnosis again.

Inspection 3 Pressure Sensor and Circuit Between Pressure Sensor and ABS Actuator and Electric Unit (Control Unit)

DTC C1142

Inspection Procedure

1. CHECKING SELF-DIAGNOSIS RESULTS (1)

Check self-diagnosis results.

Self-diagnosis results
CONSULT-II display items
PRESS SEN CIRCUIT

Does "PRESS SEN CIRCUIT" appear on self-diagnosis display?

- YES >> GO TO 2.
- NO >> Inspection is completed.

2. CHECKING SELF-DIAGNOSIS RESULTS (2)

1. Disconnect pressure sensor connector E91 and ABS actuator and electric unit (control unit) connector E39. Then reconnect them securely.
2. Perform ABS actuator and electric unit (control unit) self-diagnosis again.

Is inspection result OK?

- OK >> Poor connection of connectors. Repair or replace suspect connector. Perform self-diagnosis again.
- NG >> GO TO 3.

3. CHECKING PRESSURE SENSOR CIRCUIT

1. Disconnect pressure sensor connector E91 and ABS actuator and electric unit (control unit) connector E39.
2. Check continuity between ABS actuator and electric unit (control unit) harness connector E39 and pressure sensor harness connector E91.

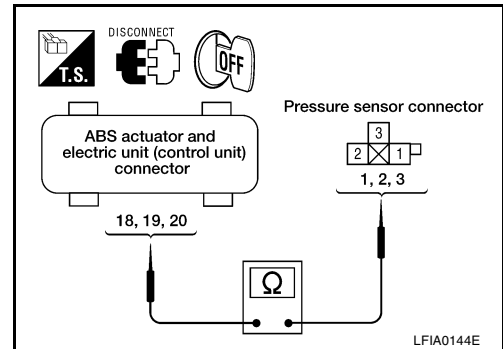

ABS actuator and electric unit (control unit) (Harness connector E39)	Pressure sensor (Harness connector E91)	Continuity
18 (LG/B)	1 (LG/B)	Yes
19 (Y/B)	2 (Y/B)	Yes
20 (OR/B)	3 (OR/B)	Yes

Is inspection result OK?

- OK >> GO TO 4.
- NG >> Open or short in harness. Repair or replace the suspect harness.

4. CHECKING PRESSURE SENSOR

Check pressure sensor value on "DATA MONITOR".

Condition	Data monitor display
Brake pedal depressed	Positive value
When brake pedal is released.	Approx. 0 bar

Is inspection result OK?

OK >> Inspection is completed.

NG >> Pressure sensor malfunction. Replace pressure sensor. Refer to [BR-14, "MASTER CYLINDER"](#).

Inspection 4 Steering Angle Sensor and Circuit Between Steering Angle Sensor and ABS Actuator and Electric Unit (Control Unit)

EFS0031B

DTC C1143

Inspection Procedure

1. CHECKING SELF-DIAGNOSIS RESULTS

Check self-diagnosis results.

Self-diagnosis results
CONSULT-II display items
ST ANGLE SEN SIGNAL

Also perform Inspection 1 for the CAN communication system.

Does "ST ANGLE SEN SIGNAL" appear on self-diagnosis display?

YES >> ● Poor connection. Repair or replace the applicable connector.

- Check connector housing for disconnected, loose, bent and collapsed terminals. If any errors are detected, repair or replace the applicable part.

NO >> GO TO 2.

2. CHECKING STEERING ANGLE SENSOR CIRCUIT

1. Disconnect ABS actuator and electric unit (control unit) harness connector and steering wheel angle sensor harness connector.
2. Check continuity between ABS actuator and electric unit (control unit) harness connector E39 and steering angle sensor harness connector M145.

ABS actuator and electric unit (control unit) (Harness connector E39)	Steering angle sensor (Harness connector M145)	Continuity
11 (OR/L)	3 (OR/L)	Yes
15 (R/B)	4 (R/B)	Yes

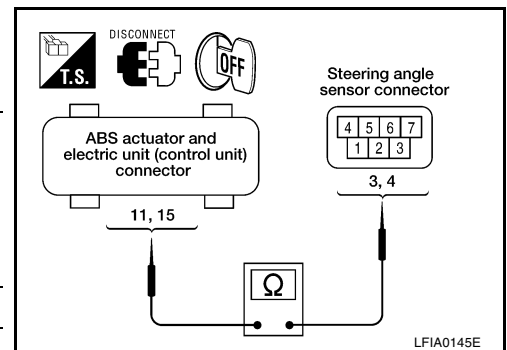

Is inspection result OK?

YES >> GO TO 3.

NO >> Open or short in harness. Repair or replace the suspect harness.

3. DATA MONITOR CHECK

Execute "DATA MONITOR" for "STR ANGLE SIG". Check that results are normal.

Steering condition	Data monitor
Driving straight	±3.5 deg
Turned 90° to right	Approx. +90 deg
Turned 90° to left	Approx. -90 deg

Is inspection result OK?

YES >> Perform ABS actuator and electric unit (control unit) self-diagnosis again.

NO >> Replace spiral cable (steering angle sensor). Refer to [SRS-42, "DRIVER AIR BAG MODULE AND SPIRAL CABLE"](#) . Adjust neutral position of steering angle sensor. Refer to [BRC-55, "Adjustment of Steering Angle Sensor Neutral Position"](#) .

Inspection 5 Yaw Rate/Side/Decel G Sensor and Circuit Between Yaw Rate/Side/Decel G Sensor and ABS Actuator and Electric Unit (Control Unit)

EFS0031C

DTC C1145, C1113, C1146

Inspection Procedure

1. CHECKING SELF-DIAGNOSIS RESULTS (1)

Check self-diagnosis results.

Self-diagnosis results
CONSULT-II display items
YAW RATE SENSOR SIDE G-SEN CIRCUIT G-SENSOR

CAUTION:

If vehicle is on turn-table at entrance to parking garage, or on other moving surface, VDC OFF indicator lamp may illuminate and CONSULT-II self-diagnosis may indicate yaw rate sensor system malfunction. However, in this case there is no malfunction in yaw rate sensor system. Take vehicle off of turn-table or other moving surface, and start engine. Results will return to normal.

Do "YAW RATE SENSOR", "SIDE G-SEN CIRCUIT" and "G-SENSOR" appear on self-diagnosis display?

YES >> GO TO 2.

NO >> Inspection is completed.

2. CHECKING SELF-DIAGNOSIS RESULTS (2)

1. Disconnect yaw rate/side/decel G sensor harness connector and ABS actuator and electric unit (control unit) harness connector.
2. Check continuity between ABS actuator and electric unit (control unit) harness connector E39 and yaw rate/side/decel G sensor connector M69.

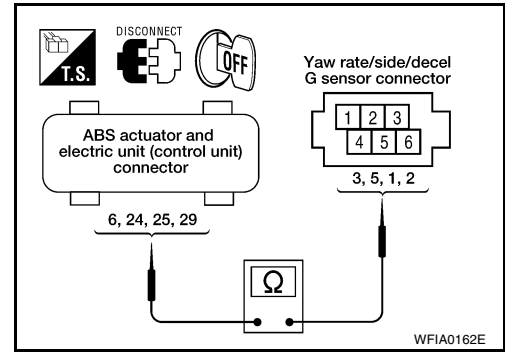

ABS actuator and electric unit (control unit) (Harness connector E39)	Yaw rate/ Side G-sensor (Harness connector M69)	Continuity
6 (G/OR)	3 (G/OR)	Yes
24 (G/B)	5 (G/B)	Yes
25 (Y/G)	1 (Y/G)	Yes
29 (B/Y)	2 (B/Y)	Yes

Is inspection result OK?

OK >> GO TO 3.

NG >> Open or short in harness. Repair or replace the suspect harness.

3. CHECKING YAW RATE/SIDE/DECEL G SENSOR CIRCUIT

Check "DATA MONITOR" for yaw rate/side/decel G sensor. Check that results are normal.

Vehicle condition	Yaw rate sensor (Data monitor standard)	Side G sensor (Data monitor standard)	Decel G sensor (Data monitor standard)
Stopped	-75 to +75 deg/s	-1 to +1 m/s ²	- 0.08 G to + 0.08 G
Turning right	Negative value	Negative value	Negative value
Turning left	Positive value	Positive value	Positive value

Is inspection result OK?

OK >> Perform ABS actuator and electric unit (control unit) self-diagnosis again.

NG >> Malfunction of yaw rate/side/decel G sensor. Replace sensor. Refer to [BRC-131, "Yaw Rate/Side/Decel G Sensor"](#). Perform ABS actuator and electric unit (control unit) self-diagnosis again.

Inspection 6 Solenoid, VDC Switching Valve, Actuator Relay and Circuits

EFS003ID

DTC C1120, C1121, C1122, C1123, C1124, C1125, C1126, C1127, C1164, C1165, C1166, C1167 or C1140

Inspection Procedure

1. CHECKING SELF-DIAGNOSIS RESULTS (1)

Check self-diagnosis results.

Self-diagnosis results
CONSULT-II display items
FR LH IN ABS SOL
FR LH OUT ABS SOL
RR RH IN ABS SOL
RR RH OUT ABS SOL
FR RH IN ABS SOL
FR RH OUT ABS SOL
RR LH IN ABS SOL
RR LH OUT ABS SOL
CV1
CV2
SV1
SV2

Do above items appear on self-diagnosis results display?

- YES >> GO TO 2.
- NO >> Inspection is completed.

2. CHECKING SELF-DIAGNOSIS RESULTS (2)

1. Disconnect ABS actuator and electric unit (control unit) connector E39. Then reconnect it securely.
2. Perform self-diagnosis again.

Do any self-diagnosis items appear?

- YES >> GO TO 3.
- NO >> Poor connection. Repair or replace the connector.

3. CHECKING SOLENOID POWER AND GROUND

1. Disconnect ABS actuator and electric unit (control unit) connector E39.
2. Check voltage between ABS actuator and electric unit (control unit) harness connector E39 and ground.

ABS actuator and electric unit (control unit) (Harness connector E39)	Body ground	Voltage (V) (Approx.)
32 (Y)	—	12

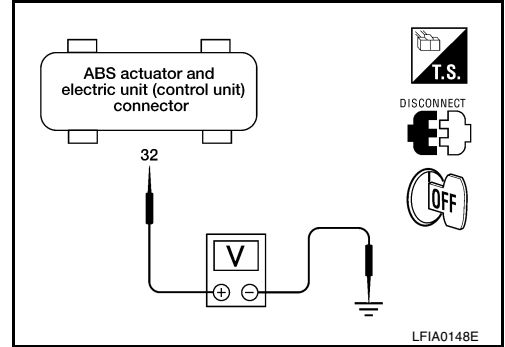

3. Check resistance between ABS actuator and electric unit (control unit) harness connector E39 and body ground.

ABS actuator and electric unit (control unit) (Harness connector E39)	Body ground	Resistance value (Ω) (Approx.)
16 (B)	—	0
47 (B)	—	0

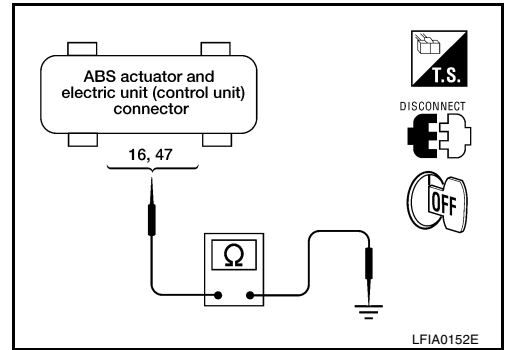

Is inspection result OK?

- OK >> Perform self-diagnosis again. If the same results appear, replace ABS actuator and electric unit (control unit). Refer to [BRC-130, "ABS Actuator and Electric Unit"](#).
- NG >> Repair harness or connectors.

Inspection 7 Actuator Motor, Motor Relay, and Circuit

EFS0031E

DTC C1111

Inspection Procedure

1. CHECKING SELF-DIAGNOSIS RESULTS (1)

Check self-diagnosis results.

Self-diagnosis results
CONSULT-II display items
PUMP MOTOR ACTUATOR RLY

Does "PUMP MOTOR" or "ACTUATOR RLY" appear in self-diagnosis results display?

- YES >> GO TO 2.
- NO >> Inspection is completed.

2. CHECKING SELF-DIAGNOSIS RESULTS (2)

1. Disconnect ABS actuator and electric unit (control unit) connector E39. Then reconnect it securely.
2. Perform self-diagnosis again.

Do any self-diagnosis items appear?

- YES >> GO TO 3.
- NO >> Poor connection. Repair or replace the applicable connector.

3. CHECKING ABS MOTOR AND MOTOR RELAY POWER SYSTEM

1. Disconnect ABS actuator and electric unit (control unit) connector.
2. Check voltage between ABS actuator and electric unit (control unit) connector E39 and body ground.

ABS actuator and electric unit (control unit) (Harness connector E39)	Body ground	Voltage (V) (Approx.)
1 (L)	—	12

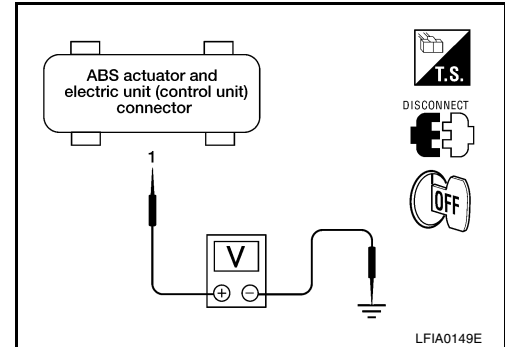

3. Check resistance between ABS actuator and electric unit (control unit) connector E39 and ground.

ABS actuator and electric unit (control unit) (Harness connector E39)	Body ground	Resistance value (Ω) (Approx.)
16 (B), 47 (B)	—	0

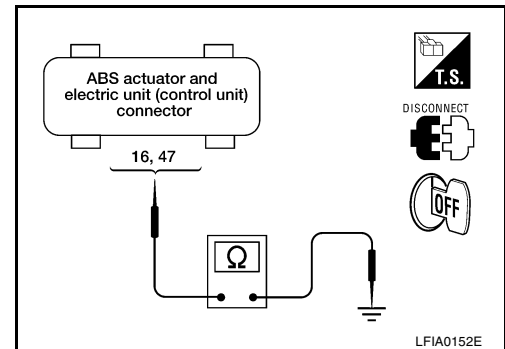

Is inspection result OK?

YES >> Perform self-diagnosis again. If the same result appears, replace ABS actuator and electric unit (control unit). Refer to [BRC-130](#), "ABS Actuator and Electric Unit".

NO >> Repair harness or connectors.

Inspection 8 Stop Lamp Switch and Circuit

EFS0031F

DTC C1116

Inspection Procedure

1. CHECKING SELF-DIAGNOSIS RESULTS

Check self-diagnosis results.

Self-diagnosis results
CONSULT-II display items
STOP LAMP SW

Does "STOP LAMP SW" appear in self-diagnosis results display?

YES >> GO TO 2.

NO >> Inspection is completed.

2. CHECKING STOP LAMP

1. Disconnect stop lamp switch connector and ABS actuator and electric unit (control unit) connector.
2. Reconnect connectors securely.
3. Start engine.
4. Repeat pumping brake pedal carefully several times, then perform self-diagnosis again.

Do any self-diagnosis items appear?

YES >> GO TO 3.

NO >> Poor connection. Repair or replace the applicable connector.

3. CHECKING STOP LAMP SWITCH CIRCUIT

1. Disconnect stop lamp switch connector and ABS actuator and electric unit (control unit) connector.
2. Check continuity between stop lamp switch harness connector M47 and ABS actuator and electric unit (control unit) harness connector E39.

ABS actuator and electric unit (control unit) (Harness connector E39)	Stop lamp switch (Harness connector M47)	Continuity
41 (BR/R)	2 (BR/R)	Yes

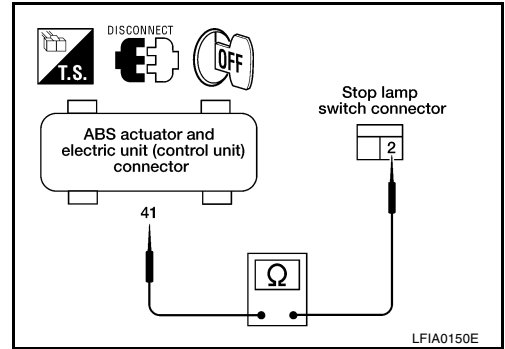

Is inspection result OK?

- OK >> Perform ABS actuator and electric unit (control unit) self-diagnosis again.
- NG >> Open or short in harness between ABS actuator and electric unit (control unit) and stop lamp switch.

Inspection 9 ABS Actuator and Electric Unit (Control Unit) Power Supply and Ground Circuit

EFS003IG

DTC C1109

Inspection Procedure

1. CHECKING SELF-DIAGNOSIS RESULT

Check self-diagnosis results.

Self-diagnosis results
CONSULT-II display items
BATTERY VOLTAGE

Does "BATTERY VOLTAGE" appear in self-diagnosis results display?

- YES >> GO TO 2.
- NO >> Inspection is completed.

2. STARTING INSPECTION

1. Disconnect ABS actuator and electric unit (control unit) connector E39. Then reconnect it securely.
2. Perform self-diagnosis.

Do any self-diagnosis items appear?

- YES >> GO TO 3.
- NO >> Poor connection. Repair or replace the connector.

3. CHECKING ABS ACTUATOR AND ELECTRIC UNIT (CONTROL UNIT) POWER SUPPLY

1. Disconnect ABS actuator and electric unit (control unit) connector E39.
2. Turn ignition switch ON (but do not start engine). Check voltage between ABS actuator and electric unit (control unit) harness connector E39 and body ground.

ABS actuator and electric unit (control unit) (Harness connector E39)	Body ground	Voltage (V) (Approx.)
4 (B/P)	—	12

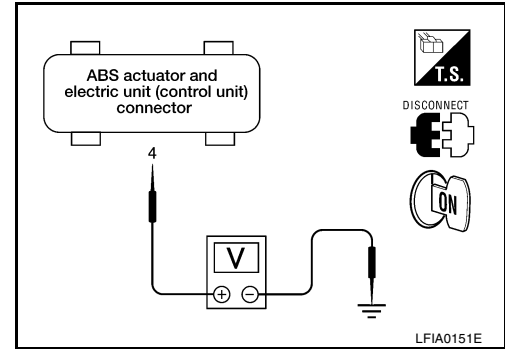

3. Check voltage between ABS actuator and electric unit (control unit) harness connector E39 and ground.

ABS actuator and electric unit (control unit) (Harness connector E39)	Body ground	Voltage (V) (Approx.)
32 (Y)	—	12

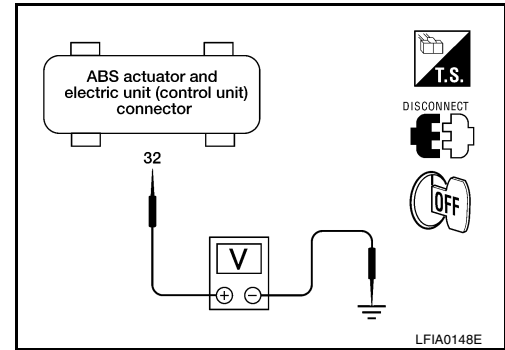

Is inspection result OK?

- OK >> GO TO 4.
- NG >> Repair power supply.

4. CHECKING ABS ACTUATOR AND ELECTRIC UNIT (CONTROL UNIT) GROUND CIRCUITS

Check ABS actuator and electric unit (control unit) ground circuits.

ABS actuator and electric unit (control unit) (Harness connector E39)	Body ground	Continuity
16 (B)	—	Yes
47 (B)	—	Yes

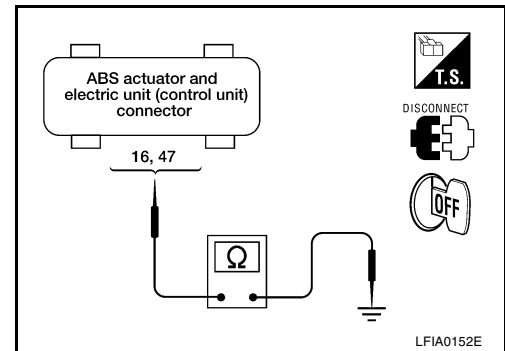

Is inspection result OK?

- OK >> Perform ABS actuator and electric unit (control unit) self-diagnosis again.
- NG >> Repair harness or connectors.

Inspection 10 When “STEERING ANGLE SENSOR HAS NOT BEEN CORRECTED” Appears on Self-Diagnosis Results Display

EFS0031H

DTC C1144

Inspection Procedure

1. CHECKING SELF-DIAGNOSIS RESULTS (1)

Check self-diagnosis results.

Self-diagnosis results
CONSULT-II display items
ST ANGLE SEN CIRCUIT

Does anything besides “ST ANGLE SEN CIRCUIT” appear on self-diagnosis results display?

- YES >> Inspect and repair the indicated items. Then perform self-diagnosis again.
- NO >> Perform adjustment of steering angle sensor neutral position. Refer to [BRC-55, "Adjustment of Steering Angle Sensor Neutral Position"](#). Then GO TO 2.

2. CHECKING SELF-DIAGNOSIS RESULTS (2)

1. Turn ignition switch OFF, and ON to erase self-diagnosis results, and perform ABS actuator and electric unit (control unit) self-diagnosis again.

Does anything appear on self-diagnosis results display?

- YES >> Replace steering angle sensor (built into spiral cable). Refer to [SRS-42, "DRIVER AIR BAG MODULE AND SPIRAL CABLE"](#) . Then perform adjustment of neutral position and perform self-diagnosis again. Refer to [BRC-55, "Adjustment of Steering Angle Sensor Neutral Position"](#) .
- NO >> Inspection is completed.

Inspection 11 Brake Fluid Level in Reservoir Tank, Communication Circuit Between ABS Actuator and Electric Unit (Control Unit) and Brake Fluid Level Switch

EFS003II

DTC C1155

Inspection Procedure

1. CHECKING SELF-DIAGNOSIS RESULTS (1)

Check self-diagnosis results.

Self-diagnosis results
CONSULT-II display items
BR FLUID LEVEL LOW

Does brake warning lamp turn on?

- YES >> Check brake linings for wear. Check brake fluid for leakage. Repair as necessary.
- NO >> GO TO 2.

2. CHECKING SELF-DIAGNOSIS RESULTS (2)

1. Disconnect brake fluid level switch connector and ABS actuator and electric unit (control unit) connector.
2. Reconnect connectors securely, then perform ABS actuator and electric unit (control unit) self-diagnosis again.

Does anything appear on self-diagnosis results display?

- YES >> Poor connector connections. Repair or replace connectors.
- NO >> GO TO 3.

3. CHECKING CIRCUIT BETWEEN BRAKE FLUID LEVEL SWITCH AND ABS ACTUATOR AND ELECTRIC UNIT (CONTROL UNIT)

1. Disconnect brake fluid level switch connector E37 and ABS actuator and electric unit (control unit) connector E39.
2. Check continuity between brake fluid level switch harness connector E37 and ABS actuator and electric unit (control unit) harness connector E39.

ABS actuator and electric unit (control unit) (Harness connector E39)	Brake fluid level switch (Harness connector E37)	Continuity
8 (GY/L)	1 (GY/L)	Yes

Is inspection result OK?

- OK >> Perform ABS actuator and electric unit (control unit) self-diagnosis again.
- NG >> Open or short in harness. Repair or replace the suspect harness.

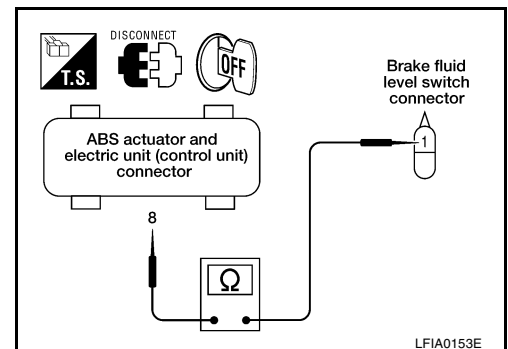

Inspection 12 CAN Communications Lines, ABS Actuator and Electric Unit (Control Unit), Steering Angle Sensor System and CAN-LAN Converter ECU (CLC)

EFS003U

DTC U1000, C1156

Inspection Procedure

1. CHECKING SELF-DIAGNOSIS RESULTS (1)

Check self-diagnosis results.

Self-diagnosis results
CONSULT-II display items
CAN COMM CIRCUIT ST ANGLE SEN COM CIR CAN COMM 1

Do self-diagnosis results indicate anything other than the above?

- YES >> Perform repair or replacement for the item indicated.
- NO >> GO TO 2.

2. CHECKING CONNECTORS AND HARNESS BETWEEN ABS ACTUATOR AND ELECTRIC UNIT (CONTROL UNIT) AND STEERING ANGLE SENSOR

1. Turn ignition switch OFF. Disconnect battery ground cable.
2. Disconnect ABS actuator and electric unit (control unit) harness connector and steering wheel angle sensor harness connector.
3. Check continuity between ABS actuator and electric unit (control unit) harness connector E39 and steering angle sensor harness connector M145.

ABS actuator and electric unit (control unit) (Harness connector E39)	Steering angle sensor (Harness connector M145)	Continuity
11 (OR/L)	3 (OR/L)	Yes
15 (R/B)	4 (R/B)	Yes

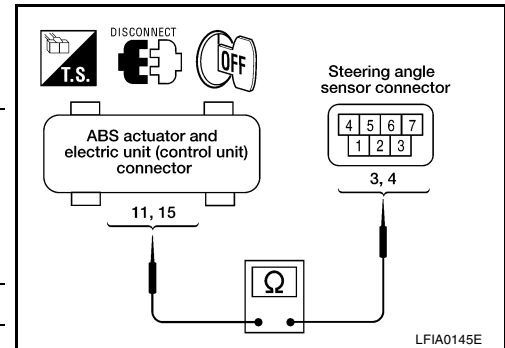

4. Check all control unit and sensor connectors. (Check for missing, bent, or collapsed terminals in terminal housing.)

Is inspection result OK?

- OK >> GO TO 3.
- NG >> Harness connector malfunction. Repair or replace. GO TO 3.

3. CHECKING CONNECTORS AND HARNESS BETWEEN ABS ACTUATOR AND ELECTRIC UNIT (CONTROL UNIT) AND CAN-LAN CONVERTER

1. Turn ignition switch OFF. Disconnect battery ground cable.
2. Disconnect ABS actuator and electric unit (control unit) harness connector and CAN-LAN converter harness connector.
3. Check continuity between ABS actuator and electric unit (control unit) harness connector E39 and CAN-LAN converter harness connector M147.

ABS actuator and electric unit (control unit) (Harness connector E39)	CAN-LAN converter (Harness connector M147)	Continuity
11 (OR/L)	5 (OR/L)	Yes
15 (R/B)	7 (R/B)	Yes

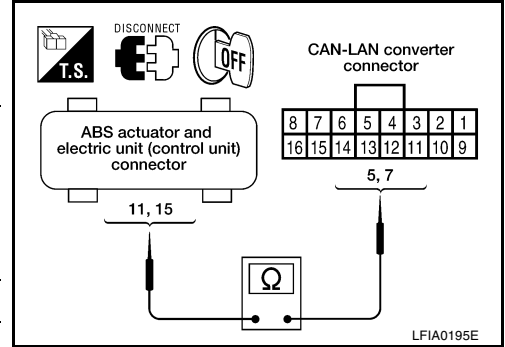

4. Check all control unit and sensor connectors. (Check for missing, bent, or collapsed terminals in terminal housing.)

Is inspection result OK?

- OK >> GO TO 4.
- NG >> Harness connector malfunction. Repair or replace. GO TO 4.

4. CHECKING SELF-DIAGNOSIS RESULTS (2)

1. Connect connectors to all control units and sensors.
2. Connect battery negative terminal. Turn ignition switch ON.
3. Erase self-diagnosis results. Then start engine and perform self-diagnosis.

Does only "ST ANGLE SEN COM CIR" appear on self-diagnosis results display?

- YES >> Replace steering angle sensor (built into spiral cable). Refer to [SRS-42, "DRIVER AIR BAG MODULE AND SPIRAL CABLE"](#). Then perform adjustment of neutral position and perform self-diagnosis again. Refer to [BRC-55, "Adjustment of Steering Angle Sensor Neutral Position"](#).
- NO >> GO TO 5.

5. CAN COMMUNICATION SYSTEM CHECK

Select "CAN DIAG SUPPORT MNTR" of data monitor items.

Normal	Error (example)
CAN COMM: OK	CAN COMM: OK
CAN CIRC 1: OK	CAN CIRC 1: UNKWN
CAN CIRC 2: UNKWN	CAN CIRC 2: UNKWN
CAN CIRC 3: UNKWN	CAN CIRC 3: UNKWN
CAN CIRC 4: UNKWN	CAN CIRC 4: UNKWN
CAN CIRC 5: OK	CAN CIRC 5: UNKWN
CAN CIRC 6: UNKWN	CAN CIRC 6: UNKWN
CAN CIRC 7: UNKWN	CAN CIRC 6: UNKWN
CAN CIRC CLC: OK	CAN CIRC CLC: UNKWN

>> Print out monitor items. Then refer to [BRC-60, "CAN COMMUNICATION"](#).

Inspection 13 ENGINE SIGNAL 1 - Engine System

DTC C1130

Inspection Procedure

1. CHECKING SELF-DIAGNOSIS RESULTS (1)

Check self-diagnosis results.

Self-diagnosis results
CONSULT-II display items
ENGINE SIGNAL 1

Do self-diagnosis results indicate anything other than the above?

- YES >> Perform repair or replacement for the item indicated.
- NO >> GO TO 2.

2. CHECK ENGINE SYSTEM

1. Perform self-diagnostic procedures for ECM.

Self-diagnosis results
CONSULT-II display items
P0101, P0102 MAF SENSOR*1
P0117, P0118 ECT SENSOR*1
P0121, P0122, P0123 TP SENSOR*1
P0125 ECT SENSOR*1
P0605 ECM*1
P1336 CKP SENSOR (COG)*1
IGNITION SIGNAL*1

*1: Out of ECM diagnostic items, the 7 items listed above cause VDC to be suspended (VDC OFF and SLIP indicators ON) and allow ABS actuator and electric unit (control unit) to indicate "ENGINE SIGNAL 1".

Do any of the above self-diagnostic items appear on the display?

- YES >> Refer to EC Section.
- NO >> GO TO 3.

3. CHECK ABS ACTUATOR AND ELECTRIC UNIT (CONTROL UNIT) TO ECM CIRCUIT

Do "ECM — ABSTCS COMM NG" and/or "ABS-TCS C/U SIGNAL" (ECM self-diagnostic items)*2 appear on display?

*2: Items which cause VDC to be suspended (VDC OFF and SLIP indicators ON) and allow ABS actuator and electric unit (control unit) to indicate "ENGINE CHECK SIG".

- YES >> Refer to [BRC-110, "Inspection 15 ENG CHECK SIG - LAN Monitoring"](#) , [BRC-111, "Inspection 16 LAN SIGNAL 2 - LAN Communication Start Procedure Incomplete"](#) and [BRC-112, "Inspection 17 LAN COMM 1 - LAN Communication System Failure"](#) .
- NO >> GO TO 4.

4. CHECK SELF-DIAGNOSTIC ITEMS

Check self-diagnostic items.

Do any other ECM self-diagnostic items appear?

- YES >> Refer to EC Section.
- NO >> Inspection end.

Inspection 14 ENG SPEED SIG - Engine Speed Signal

DTC C1168

EFS003IL

1. INSPECTION START A

Check self-diagnosis results.

Self-diagnosis results
CONSULT-II display items
ENGINE SPEED SIG

Do self-diagnosis results indicate anything other than the above? B

- YES >> Perform repair or replacement for the item indicated.
- NO >> GO TO 2. C

2. CHECK ENGINE SYSTEM D

1. Perform self-diagnostic procedures for ECM. E

Self-diagnosis results
CONSULT-II display items
P1336 CKP SENSOR (COG)*1

*1: Out of ECM diagnostic items, only P1336 CKP SENSOR (COG) causes VDC to be suspended (VDC OFF and SLIP indicators ON) and allow ABS actuator and electric unit (control unit) to indicate "ENGINE SPEED SIG". G

Does the above self-diagnostic item appear on the display? H

- YES >> Refer to EC Section.
- NO >> GO TO 3. I

3. CHECK CAN-LAN CONVERTER (CLC) TO ECM CIRCUIT J

Do "ECM-ABS/TCS/VDC COMM NG" and/or "ABS/TCS/VDC C/U SIGNAL" (ECM self-diagnostic items)*2 appear on display? K

*2: Items which cause VDC to be suspended (VDC OFF and SLIP indicators ON) and allow ABS actuator and electric unit (control unit) to indicate "ENGINE CHECK SIG". L

- YES >> Refer to [BRC-110, "Inspection 15 ENG CHECK SIG - LAN Monitoring"](#) , [BRC-111, "Inspection 16 LAN SIGNAL 2 - LAN Communication Start Procedure Incomplete"](#) and [BRC-112, "Inspection 17 LAN COMM 1 - LAN Communication System Failure"](#) . M
- NO >> GO TO 4.

4. CHECK CONNECTORS M

1. Disconnect CLC connector and ECM connector.
2. Check for terminal separation, looseness or bending, etc. at connector housing. If necessary, repair faulty terminals. Then reconnect them securely.
3. Perform self-diagnosis again.

Do any self-diagnosis items appear?

- YES >> GO TO 5.
- NO >>
 - Check harness connectors M147, F29
 - Check harness for open or short between ECM connector and CLC connector
If NG, repair harness or connectors.

5. CHECK LAN CIRCUIT

1. Disconnect CAN-LAN converter (CLC) connector and ECM connector.
2. Check continuity between CLC connector M147 terminal 14 (P/L) and ECM connector terminal 68 (W/G).

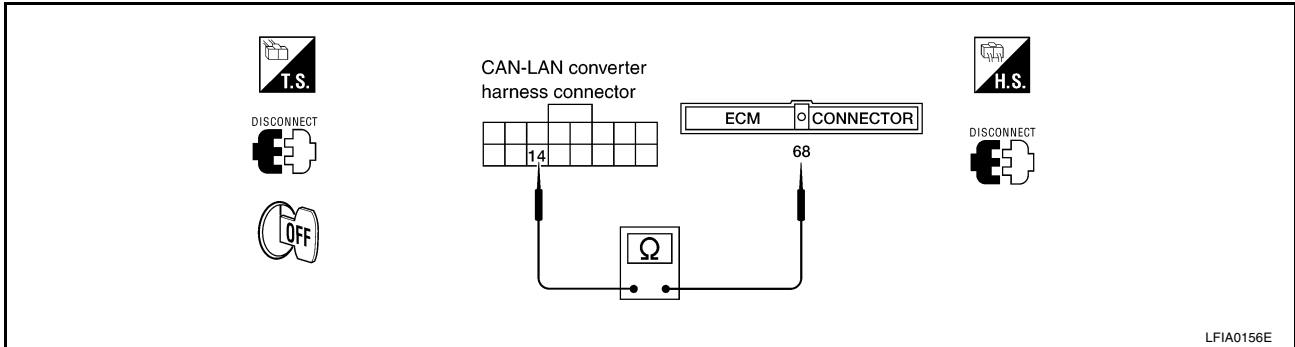

Continuity should exist.

OK or NG?

- OK >> Connect connectors and repeat self-diagnosis. Repair or replace.
- NG >> Repair harness or connectors.

Inspection 15 ENG CHECK SIG - LAN Monitoring

EFS003IM

DTC C1171

1. INSPECTION START

Check self-diagnosis results.

Self-diagnosis results
CONSULT-II display items
ENG CHECK SIG

Do self-diagnosis results indicate anything other than the above?

- YES >> Perform repair or replacement for the item indicated.
- NO >> GO TO 2.

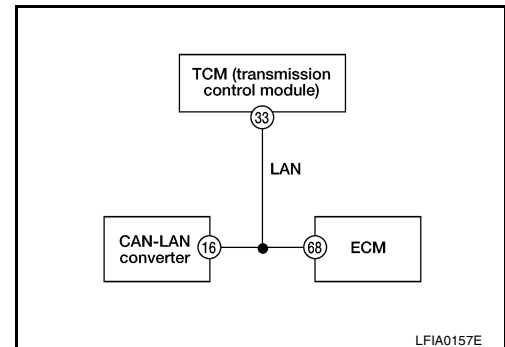

2. CHECK ENGINE SYSTEM

1. Perform self-diagnostic procedures for ECM.

Self-diagnosis results
CONSULT-II display items
CAN-LAN CONVERTER COMM NG

Does the above self-diagnostic item appear on the display?

- YES >> GO TO 6.
- NO >> GO TO 3.

3. CHECK ABS ACTUATOR AND ELECTRIC UNIT (CONTROL UNIT) SELF-DIAGNOSIS (1)

Does "LAN COMM 1" appear on display?

- YES >> GO TO 4.
- NO >> Replace CLC. Refer to [BRC-131, "CAN-LAN Converter \(CLC\)"](#).

4. CHECK ABS ACTUATOR AND ELECTRIC UNIT (CONTROL UNIT) SELF-DIAGNOSIS (2)

Does any other self-diagnostic item appear on display?

- YES >> Repair or replace.
- NO >> GO TO 5.

5. CHECK VOLTAGE

1. Check if battery voltage is too low (less than 9V) or battery terminals are loose.

OK or NG?

- OK >> GO TO 6.
- NG >> Faulty battery.

6. CHECK LAN CIRCUIT

1. Disconnect CAN-LAN converter (CLC), TCM and ECM connectors.
2. Check continuity between connector terminals.

CLC	ECM	TCM
16 (W/G)	68 (W/G)	—
16 (W/G)	—	33 (W/G)
—	68 (W/G)	33 (W/G)

Continuity should exist.

OK or NG?

- OK >> Connect connectors and repeat self-diagnosis. Repair or replace.
- NG >>
 - Check the following
 - Harness connectors M147, M78, F29
 - Harness for open or short between ABS actuator and electric unit (control unit) and ECM
 - Harness for open or short between ABS actuator and electric unit (control unit) and TCM
 - Harness for open or short between ECM and TCM
 - If NG, repair harness or connectors.

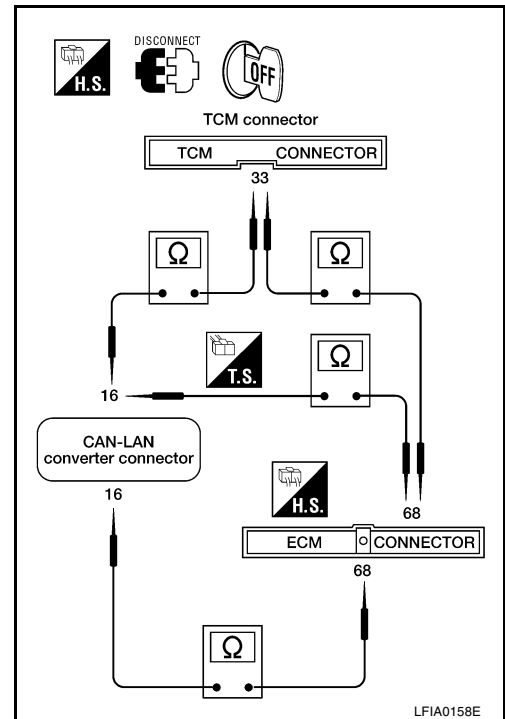

Inspection 16 LAN SIGNAL 2 - LAN Communication Start Procedure Incomplete

EFS003IN

DTC C1172

1. INSPECTION START

Check self-diagnosis results.

Self-diagnosis results
CONSULT-II display items
LAN SIGNAL 2

Do self-diagnosis results indicate anything other than the above?

- YES >> Perform repair or replacement for the item indicated.
- NO >> GO TO 2.

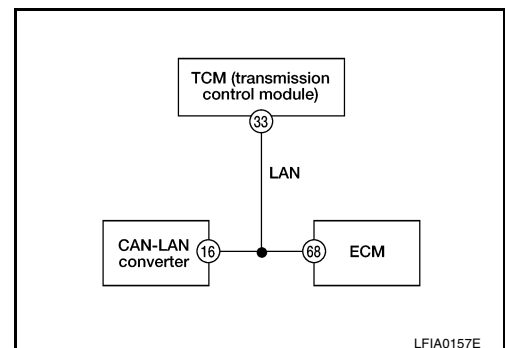

2. CHECK ENGINE SYSTEM

1. Perform self-diagnostic procedures for ECM.

Is self-diagnosis for ECM able to start?

YES >> GO TO 3.

NO >> ● Repair or replace data link connector to ECM harness or connector
● Faulty ECM (MIL remains ON during operation)

3. CHECK ABS ACTUATOR AND ELECTRIC UNIT (CONTROL UNIT) SELF-DIAGNOSIS

Check self-diagnosis results.

Self-diagnosis results

CONSULT-II display items

CAN-LAN CONVERTER COMM NG

Does "CAN-LAN CONVERTER COMM NG" appear on display?

YES >> Check LAN circuit. Refer to [BRC-110, "Inspection 15 ENG CHECK SIG - LAN Monitoring"](#) .

NO >> GO TO 4.

4. CHECK START SIGNAL TO ECM

Check START signal to ECM.

OK or NG?

YES >> ● If other items appear on display, repair or replace
● Repeat self-diagnosis procedures for control unit

NO >> Repair START input to ECM.

Inspection 17 LAN COMM 1 - LAN Communication System Failure

EFS00310

DTC C1169

1. INSPECTION START

Check self-diagnosis results.

Self-diagnosis results

CONSULT-II display items

LAN COMM 1

Do self-diagnosis results indicate anything other than the above?

YES >> Perform repair or replacement for the item indicated.

NO >> GO TO 2.

2. CHECK ENGINE SYSTEM

1. Perform self-diagnostic procedures for ECM.

Does "CAN-LAN CONVERTER" appear on display?

YES >> Check LAN circuit. Refer to [BRC-110, "Inspection 15 ENG CHECK SIG - LAN Monitoring"](#) .

NO >> GO TO 3.

3. CHECK ECM POWER SUPPLY

Check ECM to battery power circuits, harness and connectors.

OK or NG?

OK >> ● Repeat self-diagnosis procedures for control unit
● If NG, replace control unit

NG >> Repair or replace.

Inspection 18 LAN SIGNAL 3 - Continued Reception After LAN Communication Starts

EFS0031P

DTC 1173

1. INSPECTION START

Check self-diagnosis results.

Self-diagnosis results
CONSULT-II display items
LAN SIGNAL 3

Do self-diagnosis results indicate anything other than the above?

- YES >> Perform repair or replacement for the item indicated.
- NO >> GO TO 2.

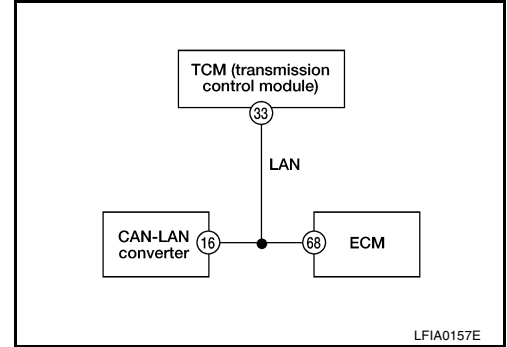

2. CHECK ENGINE SYSTEM

1. Perform self-diagnostic procedures for ECM.

Does "CAN-LAN CONVERTER COMM NG" appear on display?

- YES >> Check ECM. Refer to EC Section.
- NO >> GO TO 3.

3. CHECK ABS ACTUATOR AND ELECTRIC UNIT (CONTROL UNIT) SELF-DIAGNOSIS

Check self-diagnosis results.

Self-diagnosis results
CONSULT-II display items
ABS-TCS C/U SIGNAL

Does "ABS-TCS C/U SIGNAL" appear on display?

- YES >> Replace CLC. Refer to [BRC-131, "CAN-LAN Converter \(CLC\)"](#). Repeat self-diagnosis for control unit.
- NO >> If other items appear on display, repair or replace.

Inspection 19 SLIP Indicator Lamp Does Not Come On When Ignition Switch is Turned On

EFS0031Q

1. INSPECTION START

Indicator lamp circuit inspection.

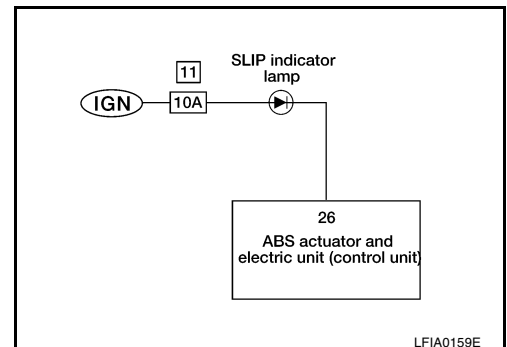

>> GO TO 2.

2. CHECK FUSE

Check 10A fuse [No. 11 located in the fuse block (J/B)]. For fuse layout, refer to [PG-9, "POWER SUPPLY ROUTING"](#) .

OK or NG?

- OK >> GO TO 3.
- NG >> Replace fuse.

3. CHECK POWER SUPPLY CIRCUIT

1. Install 10A fuse.
2. Disconnect ABS actuator and electric unit (control unit) connector.
3. Turn ignition switch ON.
4. Check voltage between ABS actuator and electric unit (control unit) connector E39 terminal 26 (B/R) and ground.

Battery voltage should exist.

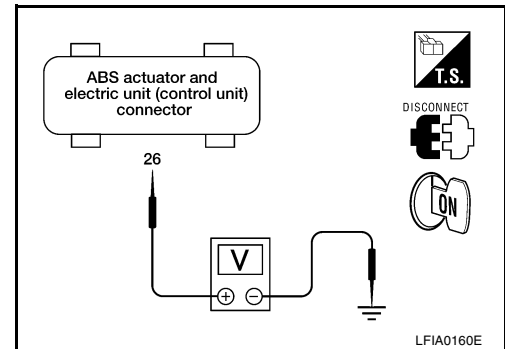

OK or NG?

- OK >> GO TO 5.
- NG >> GO TO 4.

4. CHECK INDICATOR BULB

Check indicator lamp bulb.

OK or NG?

- OK >> Repair harness or connectors between fuse and ABS actuator and electric unit (control unit) terminal 26 (including combination meter).
- NG >> Replace combination meter.

5. CHECK CIRCUIT

1. Turn ignition switch OFF.
2. Disconnect ABS actuator and electric unit (control unit) and combination meter connectors.
3. Check continuity between ABS actuator and electric unit (control unit) connector E39 terminal 26 (B/R) and combination meter connector M38 terminal 5 (B/R).

Continuity should exist.

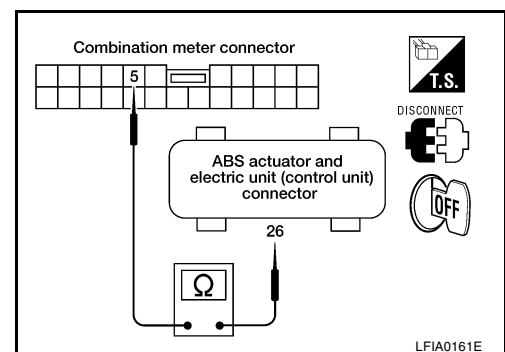

OK or NG?

- OK >> Reconnect connectors and perform self-diagnosis. Repair or replace.
- NG >> ● Check harness connectors E39, M38
 - Harness for open or short between ABS actuator and electric unit (control unit) and combination meter

Inspection 20 VDC OFF Indicator Lamp Does Not Come On When Ignition Switch Is Turned On

EFS0031R

1. INSPECTION START

Indicator lamp circuit inspection.

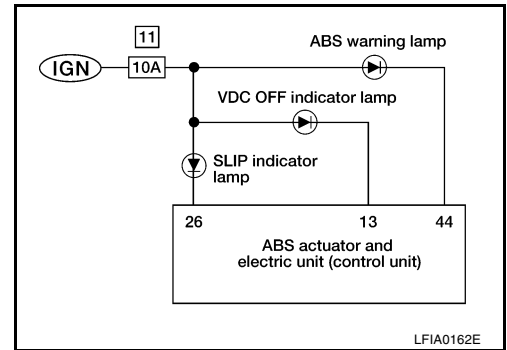

>> GO TO 2.

2. CHECK FUSE

Check 10A fuse [No. 11 located in the fuse block (J/B)]. For fuse layout, refer to [PG-9, "POWER SUPPLY ROUTING"](#).

OK or NG?

- OK >> GO TO 3.
- NG >> Replace fuse.

3. CHECK POWER SUPPLY CIRCUIT

1. Install 10A fuse.
2. Disconnect ABS actuator and electric unit (control unit) connector.
3. Turn ignition switch ON.
4. Check voltage between ABS actuator and electric unit (control unit) connector E39 terminal 13 (L/B) and ground.

Battery voltage should exist.

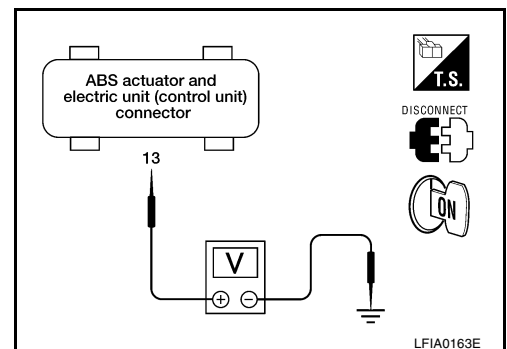

OK or NG?

- OK >> GO TO 5.
- NG >> GO TO 4.

4. CHECK INDICATOR BULB

Check indicator lamp bulb.

OK or NG?

- OK >> Repair harness or connectors between fuse and ABS actuator and electric unit (control unit) terminal 13 (including combination meter).
- NG >> Replace combination meter.

5. CHECK CIRCUIT

1. Turn ignition switch OFF.
2. Disconnect ABS actuator and electric unit (control unit) and combination meter connectors.
3. Check continuity between ABS actuator and electric unit (control unit) connector E39 terminal 13 (L/B) and combination meter connector M38 terminal 4 (L/B).

Continuity should exist.

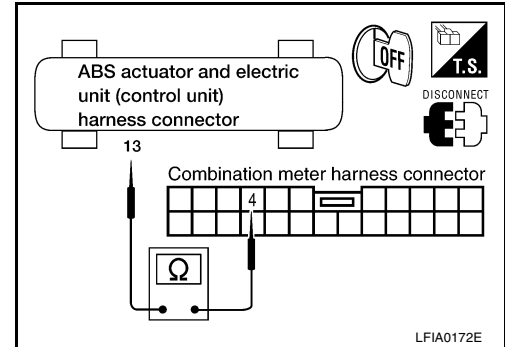

OK or NG?

- OK >> Reconnect connectors and perform self-diagnosis. Repair or replace.
- NG >> ● Check harness connectors E39, M38
 - Harness for open or short between ABS actuator and electric unit (control unit) and combination meter

Inspection 21 VDC OFF Switch Is Inoperative

EFS003IS

1. INSPECTION START

Inspect VDC OFF switch circuit.

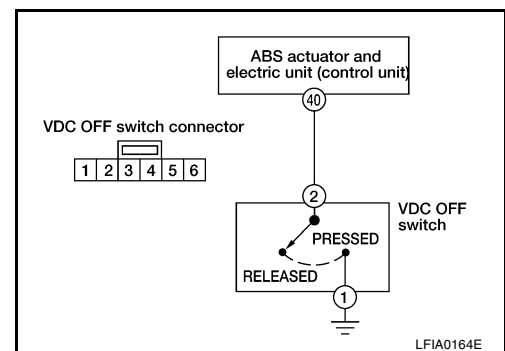

>> GO TO 2.

2. CHECK VDC OFF SWITCH

Refer to [BRC-121, "VDC OFF SWITCH"](#) .

OK or NG?

- OK >> GO TO 3.
- NG >> Replace VDC OFF switch.

3. CHECK VDC OFF SWITCH CIRCUIT FOR OPEN

1. Disconnect ABS actuator and electric unit (control unit) connector and VDC OFF switch connector.
2. Check continuity between ABS actuator and electric unit (control unit) connector E39 terminal 40 (PU/W) and VDC OFF switch connector M146 terminal 2 (PU/W).

Continuity should exist.

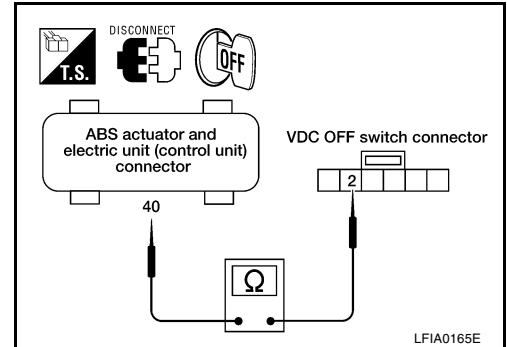

OK or NG?

- OK >> GO TO 4.
- NG >> Repair harness or connectors.

4. CHECK VDC OFF SWITCH CIRCUIT FOR SHORT

1. Check continuity between VDC OFF switch connector M146 terminal 2 (PU/W) and ground.

Continuity should not exist.

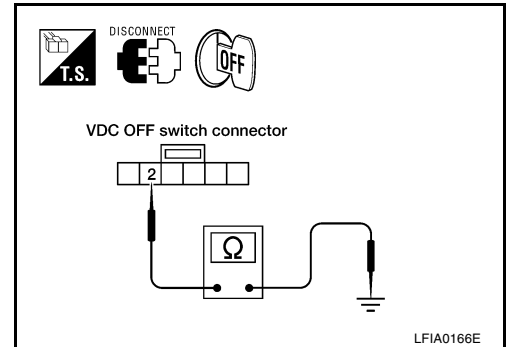

OK or NG?

- OK >> GO TO 5.
- NG >> Repair harness or connectors.

5. CHECK GROUND CIRCUIT

1. Check continuity between VDC OFF switch connector M146 terminal 1 (G/R) and ground.

Continuity should exist.

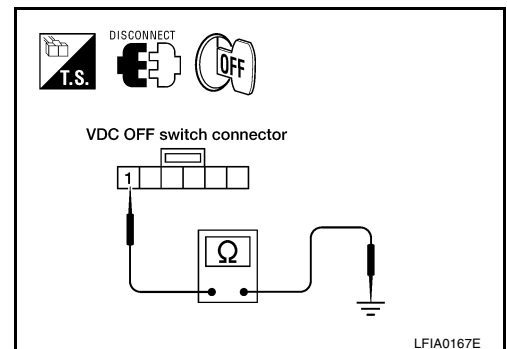

OK or NG?

- OK >> Reconnect connectors and perform self-diagnosis. Repair or replace.
- NG >> Repair harness or connectors.

Inspection 22 CAN-LAN Converter Power Supply Circuit

EFS0031T

DTC C1177

1. SELF-DIAGNOSIS RESULT CHECK 1

Check self-diagnosis results.

Self-diagnosis results
CONSULT-II display items
CLC BATTERY VOLTAGE [ABNORMAL]

Do self-diagnosis results indicate anything other than the above?

- YES >> Perform repair or replacement for the item indicated.
- NO >> GO TO 2.

2. SELF-DIAGNOSIS RESULT CHECK 2

1. Disconnect the CAN-LAN converter (CLC) connector. Securely connect it again.
2. Perform self-diagnosis.

Does "CLC BATTERY VOLTAGE [ABNORMAL]" appear on display?

- YES >> GO TO 3.
- NO >> Repair or replace the connector.

3. CHECK CLC POWER SUPPLY CIRCUIT

1. Disconnect CLC connector.
2. Turn ignition switch ON.
3. Check voltage between CLC connector M147 terminal 1 (W/B) and ground.

Battery voltage should exist.

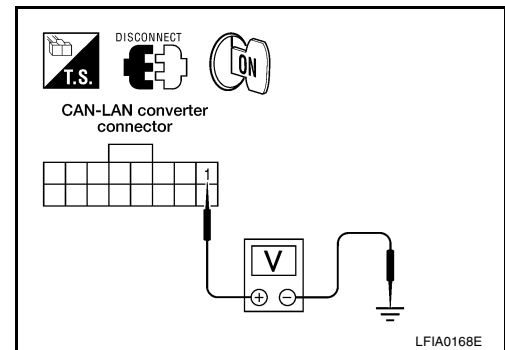

OK or NG?

- OK >> GO TO 4.
- NG >> Repair harness or connectors.

4. CHECK CLC GROUND CIRCUIT

1. Check continuity between CLC connector M147 terminal 10 (B) and ground.

Continuity should exist.

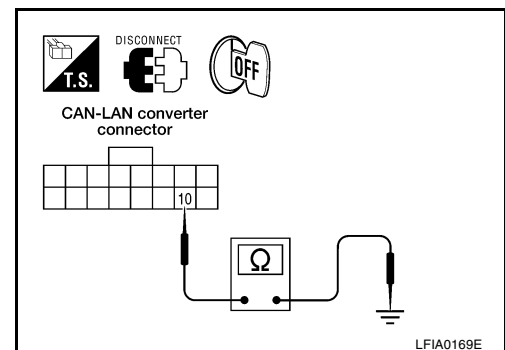

OK or NG?

- OK >> Reconnect connectors and perform self-diagnosis. Repair or replace.
- NG >> Repair harness or connectors.

Inspection 23 CAN CIRCUIT 1 - CAN Communication System Failure

EFS003IU

DTC C1174

1. INSPECTION START

Check self-diagnosis results.

Self-diagnosis results
CONSULT-II display items
CAN CIRCUIT 1

Do self-diagnosis results indicate anything other than the above?

- YES >> Perform repair or replacement for the item indicated.
- NO >> Refer to [BRC-106, "Inspection 12 CAN Communications Lines, ABS Actuator and Electric Unit \(Control Unit\), Steering Angle Sensor System and CAN-LAN Converter ECU \(CLC\)"](#).

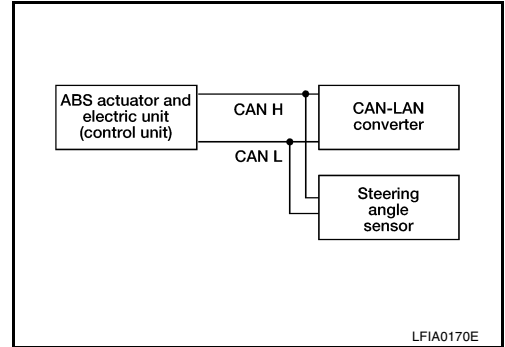

Inspection 24 CAN-LAN Converter (CLC) Control Unit

EFS003IV

BRC

1. INSPECTION START

Check self-diagnosis results.

Self-diagnosis results
CONSULT-II display items
CLC CONTROL UNIT

Do self-diagnosis results indicate anything other than the above?

- YES >> Perform repair or replacement for the item indicated.
- NO >> Replace CAN-LAN converter. Refer to [BRC-131, "CAN-LAN Converter \(CLC\)"](#). Perform self-diagnosis again.

Inspection 25 ABS Warning Lamp Does Not Come On When Ignition Switch Is Turned On

EFS003IW

1. INSPECTION START

Warning lamp circuit inspection.

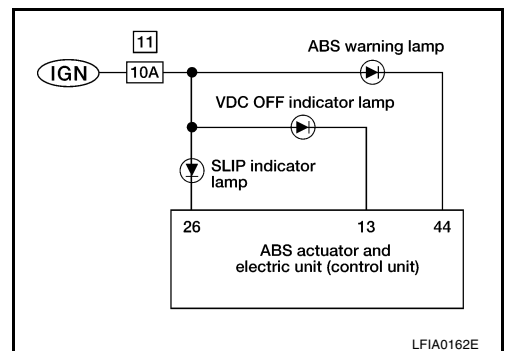

>> GO TO 2.

2. CHECK FUSE

Check 10A fuse [No. 11 located in the fuse block (J/B)]. For fuse layout, refer to [PG-9, "POWER SUPPLY ROUTING"](#) .

OK or NG?

- OK >> GO TO 3.
- NG >> Replace fuse.

3. CHECK POWER SUPPLY CIRCUIT

1. Install 10A fuse.
2. Disconnect ABS actuator and electric unit (control unit) connector.
3. Turn ignition switch ON.
4. Check voltage between ABS actuator and electric unit (control unit) connector E39 terminal 44 (L/W) and ground.

Battery voltage should exist.

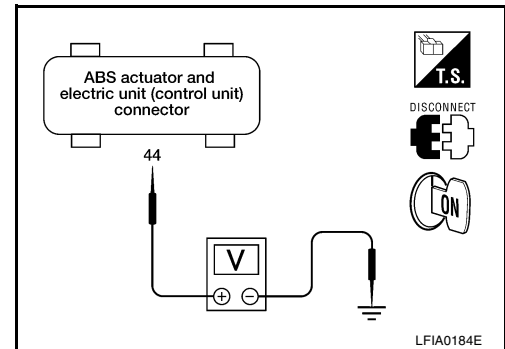

OK or NG?

- OK >> GO TO 5.
- NG >> GO TO 4.

4. CHECK INDICATOR BULB

Check indicator lamp bulb.

OK or NG?

- OK >> Repair harness or connectors between fuse and ABS actuator and electric unit (control unit) terminal 44 (including combination meter).
- NG >> Replace combination meter.

5. CHECK CIRCUIT

1. Turn ignition switch OFF.
2. Disconnect ABS actuator and electric unit (control unit) and combination meter connectors.
3. Check continuity between ABS actuator and electric unit (control unit) connector E39 terminal 44 (L/W) and combination meter connector M38 terminal 24 (L/W).

Continuity should exist.

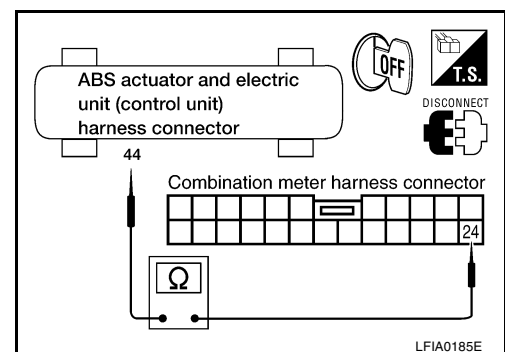

OK or NG?

- OK >> Reconnect connectors and perform self-diagnosis. Repair or replace.
- NG >> ● Check harness connectors E39, M38
 - Harness for open or short between ABS actuator and electric unit (control unit) and combination meter

Inspection 26 When "DECEL G-SENSOR" Appears on Self-Diagnosis Results Display

EFS0031X

DTC 1113

1. CHECKING SELF-DIAGNOSIS RESULTS (1)

Check self-diagnosis results.

Self-diagnosis results
CONSULT-II display items
DECEL G-SENSOR

Does anything besides "DECEL G-SENSOR" appear on self-diagnosis results display?

- YES >> Inspect and repair the indicated items. Then perform self-diagnosis again.
- NO >> Perform calibration of decel G-sensor. Refer to [BRC-55, "Calibration of Decel G Sensor"](#) .

2. CHECKING SELF-DIAGNOSIS RESULTS (2)

Turn ignition switch OFF and ON to erase self-diagnosis results and perform VDC/TCS/ABS self-diagnosis.

Does anything appear on self-diagnosis results display?

- YES >> Replace decel G-sensor. Refer to [BRC-131, "Yaw Rate/Side/Decel G Sensor"](#) . Then perform calibration of decel G-sensor and self-diagnosis again. Refer to [BRC-55, "Calibration of Decel G Sensor"](#) .
- NO >> Inspection is completed.

Inspecting Components
VDC OFF SWITCH

EFS0031Y

- Remove VDC OFF switch. Check continuity between terminals 1 and 2 as follows.

Switch condition:	Continuity
Pressed	: Yes
Released	: No

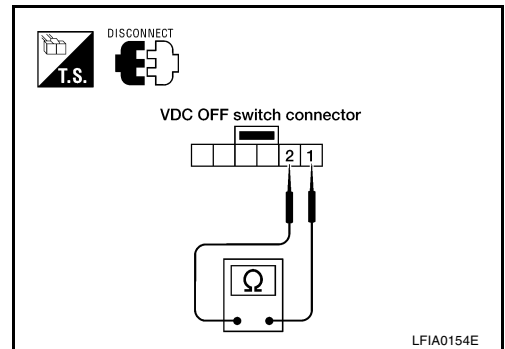

Symptom 1 ABS Works Frequently

Inspection Procedure

1. STARTING INSPECTION

Inspect wheel sensor system.

- Sensor mounting inspection
- Sensor pick-up inspection for iron chips
- Sensor rotor inspection (e.g. Number of teeth, damaged teeth)
- Sensor connector engagement inspection

Is inspection result OK?

- OK >> GO TO 2.
 NG >> Repair wheel sensor and rotor system.

2. CHECKING FOR LOOSENESS

Check for looseness of front axle.

Is inspection result OK?

- OK >> GO TO [BRC-122, "Symptom 2 Unexpected Pedal Reaction"](#) .
 NG >> Axle inspection and repair.

Symptom 2 Unexpected Pedal Reaction

Inspection Procedure

1. BRAKE PEDAL STROKE INSPECTION

Check brake pedal stroke.

Is stroke excessively long?

- YES >> Check bleeding and brake system.
 NO >> GO TO 2.

2. CHECKING PEDAL FORCE

Check that brake is effective with pedal depressed.

Is pedal heavy, but effective?

- YES >> Normal.
 NO >> GO TO 3.

3. CONNECTOR AND PERFORMANCE INSPECTION

Disconnect ABS actuator and electric unit (control unit) connector to deactivate ABS function. Check that brake is effective.

Is brake effective?

- YES >> GO TO 4.
 NO >> Brake line inspection.

4. CHECKING ABS WARNING LAMP INDICATION

Check that ABS warning lamp illuminates.

Is inspection result OK?

- OK >> Perform self-diagnosis.
 NG >> GO TO 5.

5. CHECKING WHEEL SENSORS

Inspect wheel sensor system.

- Sensor mounting inspection
- Check sensor pick-up for adhering iron chips.
- Sensor rotor inspection (e.g. Number of teeth, damaged teeth)
- Sensor connector engagement inspection

Is inspection result OK?

OK >> Normal.

NG >> Repair wheel sensor and rotor system.

Symptom 3 Long Stopping Distance

EFS003J1

Inspection Procedure

1. STARTING INSPECTION

Check that stopping distance increases only on snowy roads and gravel roads.

Is inspection result OK?

OK >> May be longer than for vehicles without ABS.

NG >> GO TO 2.

2. CHECKING PERFORMANCE

Disconnect ABS actuator and electric unit (control unit) to deactivate ABS function.

Is stopping distance still long?

YES >> Inspect brake lines for leaks or damage. Repair as necessary. Bleed brakes. Refer to [BR-10](#), "[Bleeding Brake System](#)".

NO >> GO TO 3.

3. CHECKING ABS WARNING LAMP INDICATION

Check that ABS warning lamp illuminates.

Is inspection result OK?

OK >> Perform self-diagnosis.

NG >> GO TO 4.

4. CHECKING WHEEL SENSORS

Inspect wheel sensor system.

- Sensor mounting inspection
- Check sensor pick-up for adhering iron chips.
- Sensor rotor inspection (e.g. Number of teeth, damaged teeth)
- Sensor connector engagement inspection

Is inspection result OK?

OK >> Normal.

NG >> Repair wheel sensor and rotor system.

Symptom 4 ABS Does Not Work

EFS003J2

Inspection Procedure

1. CHECKING ABS WARNING LAMP INDICATION

Check that ABS warning lamp illuminates.

Is inspection result OK?

OK >> Perform self-diagnosis.

NG >> GO TO 2.

2. CHECKING WHEEL SENSORS

Inspect wheel sensor system.

- Sensor mounting inspection
- Check sensor pick-up for adhering iron chips.
- Sensor rotor inspection (e.g. Number of teeth, damaged teeth)
- Sensor connector engagement inspection

Is inspection result OK?

- OK >> Normal.
 NG >> Repair wheel sensor and rotor system.

Symptom 5 Pedal Vibration and Noise

EFS003J3

Inspection Procedure

1. INSPECTION (1)

Check brake system for pedal vibration or noise at engine start.

Is inspection result OK?

- OK >> Perform self-diagnosis.
 NG >> GO TO 2.

2. INSPECTION (2)

Check for vibration during soft braking (just placing foot on pedal).

CAUTION:

ABS may activate in conditions such as those listed below, when wheel speed changes.

- Gear shifting
- Turning at high speed
- Passing through gusts of wind

Is inspection result OK?

- OK >> GO TO 3.
 NG >> Normal.

3. INSPECTION (3)

Does vibration occur during normal braking?

CAUTION:

In addition to activation for sudden braking, ABS may activate in conditions such as those listed below.

- Roads with low friction coefficients
- Turning at high speed
- Passing through gusts of wind

Is inspection result OK?

- OK >> GO TO 4.
 NG >> Normal.

4. INSPECTION (4)

Check for vibration when engine speed is increased while vehicle is stopped.

Is inspection result OK?

- OK >> GO TO 5.
 NG >> ● Normal.

CAUTION:

Vibration may occur when vehicle is stopped.

5. INSPECTION (5)

Check for vibration when switches of electrical components are operated.

Is inspection result OK?

- OK >> Check for any wireless devices, antennas, or antenna lead near ABS actuator and electric unit (control unit) (including wiring) or CAN-LAN converter (CLC).
- NG >> GO TO 6.

6. CHECKING ABS WARNING LAMP INDICATION

Confirm ABS warning lamp turns on.

Is inspection result OK?

- OK >> Perform self-diagnosis.
- NG >> GO TO 7.

7. CHECKING WHEEL SENSORS

Inspect wheel sensor system.

- Sensor mounting inspection
- Sensor pick-up inspection for iron chips (e.g. Number of teeth, damaged teeth)
- Sensor connector engagement inspection
- Inspection of wheel sensor circuit

Is inspection result OK?

- OK >> Normal.
- NG >> Repair wheel sensor and rotor system.

Symptom 6 Vehicle Behaves Jerkily During VDC/TCS/ABS Operation

EFS003J4

Inspection Procedure

1. CHECKING ENGINE SPEED SIGNAL

On CONSULT-II, perform "DATA MONITOR" for ABS actuator and electric unit (control unit).

Is engine speed at idle 400 rpm or higher?

- OK >> Normal.
- NG >> GO TO 2.

2. CHECKING SELF-DIAGNOSIS RESULTS (1)

Perform ABS actuator and electric unit (control unit) self-diagnosis.

Does anything appear on self-diagnosis results display?

- OK >> Inspect and repair items indicated. Then perform ABS actuator and electric unit (control unit) self-diagnosis again.
- NG >> GO TO 3.

3. ECM SELF-DIAGNOSIS RESULT ITEM CHECK

Perform the ECM self-diagnosis.

Is the result of self-diagnosis "P1336 CKP SENSOR (COG)"?

- YES >> Refer to EC Section.
- NO >> GO TO 4.

4. CHECKING SELF-DIAGNOSIS RESULTS (2)

Disconnect ABS actuator and electric unit (control unit) and ECM connectors. Then reconnect them securely. Perform the self-diagnosis again.

Is inspection result OK?

- OK >> Connector open, shorted or damaged. Repair or replace connector.
- NG >> GO TO 5.

5. CHECKING SELF-DIAGNOSIS RESULTS (3)

Perform the A/T self-diagnosis.

Is inspection result OK?

- OK >> GO TO 6.
- NG >> Repair or replace parts at location indicated.

6. CHECKING SELF-DIAGNOSIS RESULTS (4)

Perform ABS actuator and electric unit (control unit) self-diagnosis again.

Does anything appear on self-diagnosis results display?

- YES >> Repair or replace parts at location indicated.
- NO >> GO TO 7.

7. CHECKING CIRCUIT BETWEEN ABS ACTUATOR AND ELECTRIC UNIT (CONTROL UNIT) AND CAN-LAN CONVERTER (CLC)

1. Disconnect ABS actuator and electric unit (control unit) and CLC connectors.
2. Check for open circuit or short circuits in harness between ABS actuator and electric unit (control unit) and CLC.
3. Check ABS actuator and electric unit (control unit) and CLC connectors.

Is inspection result OK?

- OK >> GO TO 8.
- NG >> Repair or replace harness connector.

8. CHECKING CIRCUIT BETWEEN CAN-LAN CONVERTER (CLC) AND ECM

1. Disconnect CLC and ECM connectors.
2. Check for open or short circuit in harness between CLC and ECM.
3. Check CLC and ECM connectors.

Is inspection result OK?

- OK >> Reconnect connectors and perform ABS actuator and electric unit (control unit) self-diagnosis again.
- NG >> Repair or replace harness connector.

Symptom 7 Poor Acceleration

EFS003J5

Inspection Procedure

1. INSPECTION START

Engine acceleration is poor while VDC/TCS is operating. Vehicle instability is caused by unstable engine rpm operation. (Engine is shaking.)

>> GO TO 2.

2. CHECK PERFORMANCE

Cancel VDC/TCS operation using VDC OFF switch and drive vehicle.

Is engine acceleration still poor?

YES >> Refer to EC section.

NO >> GO TO 3.

3. CHECK SELF-DIAGNOSIS (TCM)

Perform self-diagnostic procedures for TCM.

Do any self-diagnosis results display?

YES >> Refer to AT Section.

NO >> GO TO 4.

4. CHECK SELF-DIAGNOSIS (VDC/TCS/ABS)

Perform self-diagnostic procedures for VDC/TCS/ABS.

Do any self-diagnosis results display?

YES >> Refer to [BRC-61, "TROUBLE DIAGNOSIS"](#) .

NO >> Inspection END.

A

B

C

D

E

BRC

G

H

I

J

K

L

M

REMOVAL AND INSTALLATION

Front Wheel Sensor

CAUTION:

Be careful not to damage sensor edge and sensor rotor teeth. When removing the front or rear wheel hub assembly, disconnect the ABS wheel sensor from the assembly and move it away.

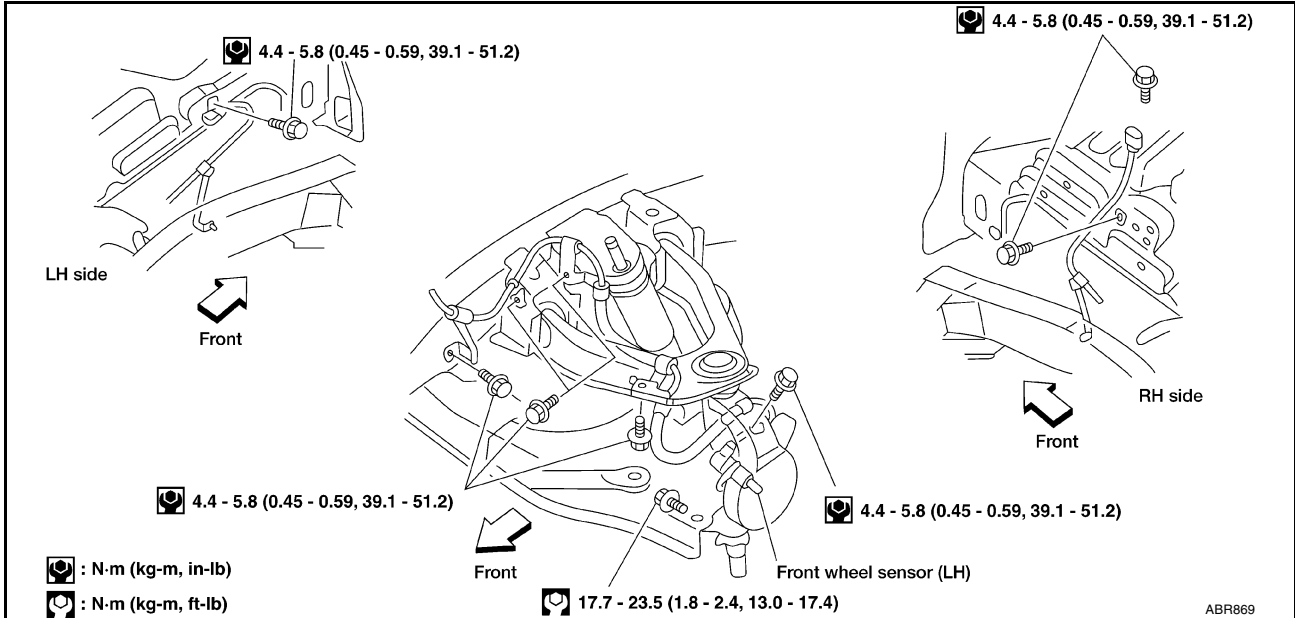

Rear Wheel Sensor

CAUTION:

Be careful not to damage sensor edge and sensor rotor teeth. When removing the front or rear wheel hub assembly, disconnect the ABS wheel sensor from the assembly and move it away.

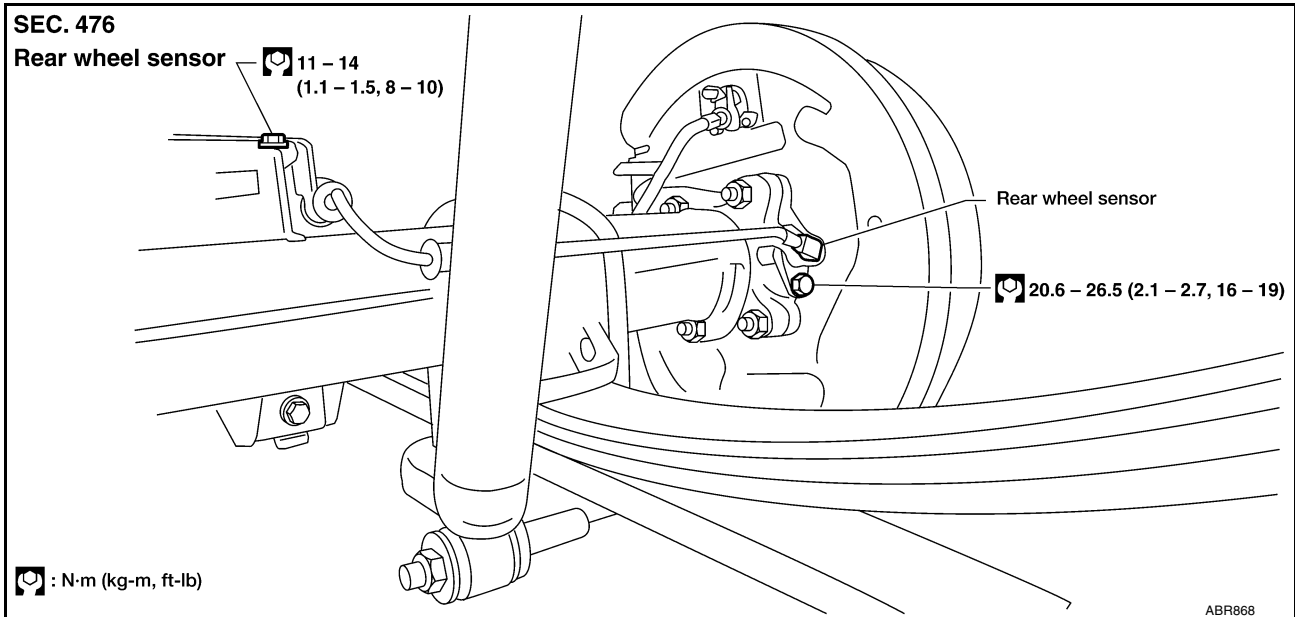

Front Sensor Rotor
REMOVAL

CAUTION:

Be careful not to damage sensor edge and sensor rotor teeth. When removing the front or rear wheel hub assembly, disconnect the ABS wheel sensor from the assembly and move it away.

REMOVAL AND INSTALLATION

[VDC/TCS/ABS]

1. Remove the front wheel hub. Refer to [FAX-14, "WHEEL HUB AND ROTOR DISC"](#).
2. Remove the sensor rotor using suitable puller, drift and bearing replacer.

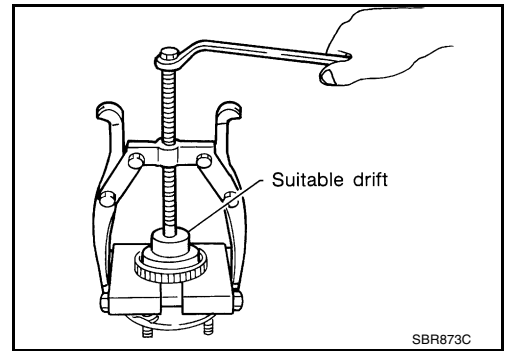

INSTALLATION

Install the sensor rotor using suitable drift and press.

- Always replace sensor rotor with new one.
- Pay attention to the direction of front sensor rotor as shown in figure.

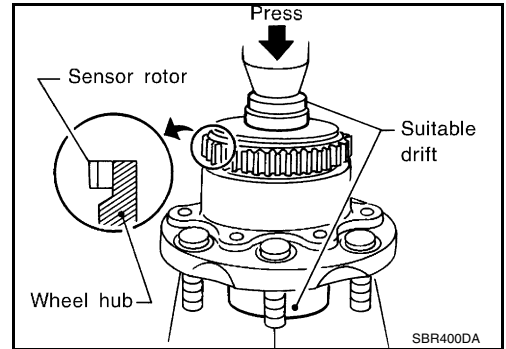

Rear Sensor Rotor REMOVAL

CAUTION:

Be careful not to damage sensor edge and sensor rotor teeth. When removing the front or rear wheel hub assembly, disconnect the ABS wheel sensor from the assembly and move it away.

- Remove the sensor rotor using Tool.

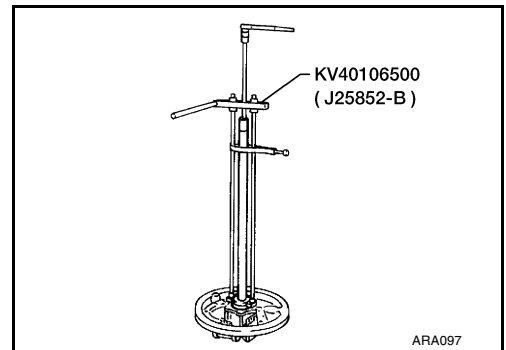

INSTALLATION

Install the sensor rotor using suitable drift and press.

- Always replace sensor rotor with a new one.
- Pay attention to the direction of front sensor rotor as shown in figure.

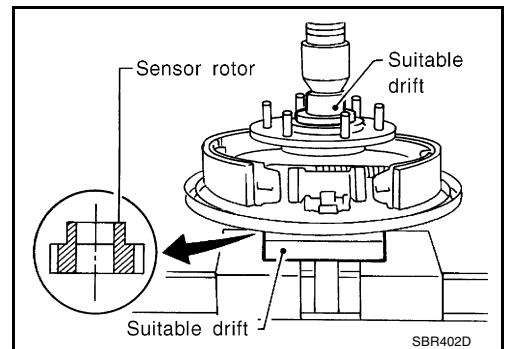

A
B
C
D
E
BRC
G
H
I
J
K
L
M

ABS Actuator and Electric Unit REMOVAL

SEC. 476

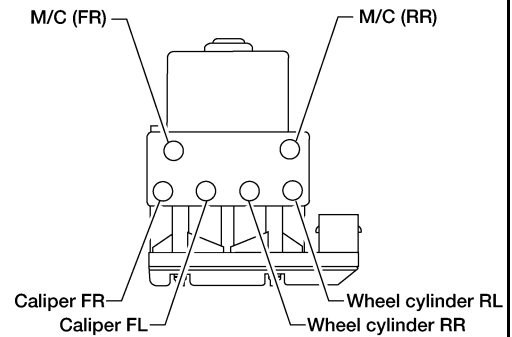
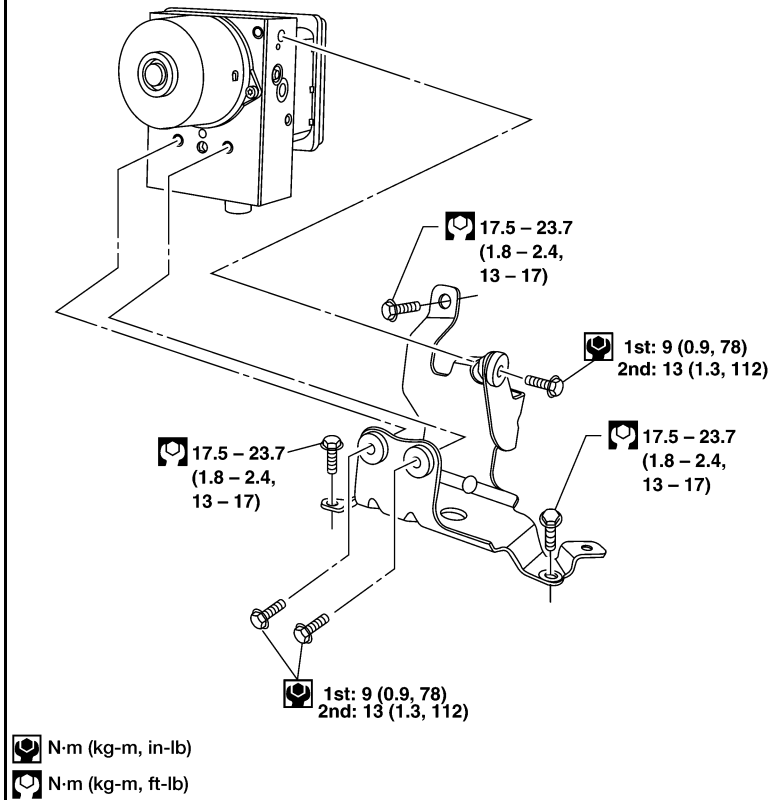

Connector lock

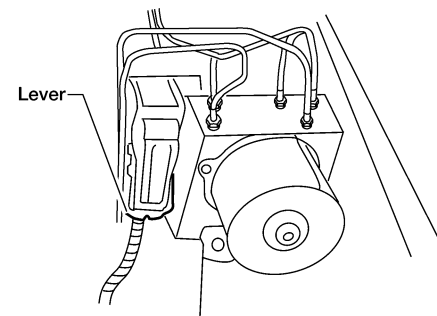

LFAI0133E

1. Disconnect battery cable.
2. Disconnect connector and brake pipes.
3. Remove fixing bolts.

INSTALLATION

CAUTION:

After installation, refill brake fluid. Then bleed air. Refer to [BR-10, "Bleeding Brake System"](#).

1. Connect brake pipes temporarily.
2. Tighten fixing bolts.
3. Tighten brake pipes.

Tightening torque : 16.7 - 21.6 N·m (1.7 - 2.2 kg-m, 13 - 15 ft-lb)

4. Connect connector and battery cable.
5. Adjust steering angle sensor neutral position. Refer to [BRC-55, "Adjustment of Steering Angle Sensor Neutral Position"](#).

Yaw Rate/Side/Decel G Sensor

EFS003JB

Always replace sensor if bumped or dropped. Otherwise, performance characteristics of sensor will be changed, which in turn changes ABS control performance characteristics.

CAUTION:

Do not exceed 9 N·m (0.9 kg-m, 80 in-lb) total tightening torque.

Tightening torque:

- Step 1 : 7 N·m (0.7 kg-m, 62 in-lb)
- Step 2 : 9 N·m (0.9 kg-m, 80 in-lb)

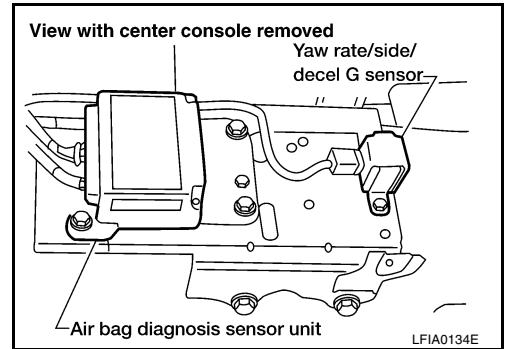

Steering Angle Sensor

EFS003JC

CAUTION:

The steering angle sensor must be adjusted after the spiral cable has been removed and reinstalled or replaced with a new one. Refer to [BRC-55, "Adjustment of Steering Angle Sensor Neutral Position"](#).

The steering angle sensor is built into the spiral cable. For removal and installation procedures, refer to [SRS-42, "DRIVER AIR BAG MODULE AND SPIRAL CABLE"](#).

CAN-LAN Converter (CLC)

EFS003JD

1. Disconnect battery cable.
2. Remove steering column cover.
3. Remove instrument lower panel driver side. Refer to [IP-10, "Removal and Installation"](#).
4. Place ASCD control unit aside.
5. Disconnect CLC harness connector.
6. Remove bolt and then remove CLC.

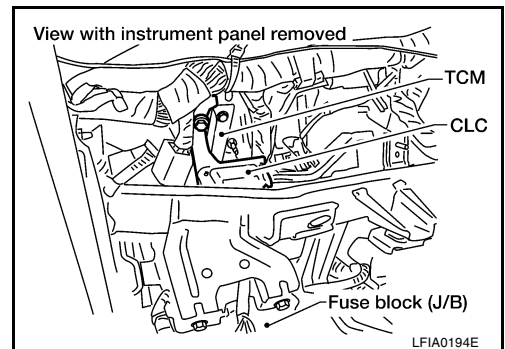

A
B
C
D
E
BRC
G
H
I
J
K
L
M

