

A
CO
C
D
E
F
G
H
I
J
K
L
M

SECTION CO

ENGINE COOLING SYSTEM

CONTENTS

KA24DE	VG33E and VG33ER
PRECAUTIONS 3	PRECAUTIONS 18
Precautions for Supplemental Restraint System (SRS) "AIR BAG" and "SEAT BELT PRE-TENSIONER" 3	Precautions for Supplemental Restraint System (SRS) "AIR BAG" and "SEAT BELT PRE-TENSIONER" 18
Precautions for Liquid Gasket 3	Precautions for Liquid Gasket 18
REMOVAL OF LIQUID GASKET 3	REMOVAL OF LIQUID GASKET 18
LIQUID GASKET APPLICATION PROCEDURE... 4	Precautions for Liquid Gasket 19
PREPARATION 5	REMOVAL OF LIQUID GASKET 19
Special Service Tools 5	LIQUID GASKET APPLICATION PROCEDURE.. 19
OVERHEATING CAUSE ANALYSIS 6	PREPARATION 20
Troubleshooting Chart 6	Special Service Tools 20
COOLING SYSTEM 7	OVERHEATING CAUSE ANALYSIS 21
Cooling Circuit 7	Troubleshooting Chart 21
ENGINE COOLANT 8	COOLING SYSTEM 22
System Check 8	Cooling Circuit 22
CHECKING COOLING SYSTEM HOSES 8	ENGINE COOLANT 23
CHECKING RADIATOR 8	System Check 23
CHECKING COOLING SYSTEM FOR LEAKS.... 8	CHECKING COOLING SYSTEM HOSES 23
CHECKING RADIATOR CAP 8	CHECKING RADIATOR 23
Refilling Engine Coolant 9	CHECKING COOLING SYSTEM FOR LEAKS... 23
WATER PUMP 10	CHECKING RADIATOR CAP 23
Removal 10	Refilling Engine Coolant 24
Inspection 11	WATER PUMP 25
Installation 11	Removal 25
THERMOSTAT 13	Inspection 26
Removal 13	Installation 26
Inspection 13	THERMOSTAT 28
Installation 13	Removal 28
RADIATOR 14	Inspection 28
Components 14	Installation 29
Removal and Installation 14	RADIATOR 30
Inspection 15	Components 30
COOLING FAN (CRANKSHAFT DRIVEN) 16	Removal and Installation 30
Removal and Installation 16	Inspection 31
Inspection 16	COOLING FAN (CRANKSHAFT DRIVEN) 32
SERVICE DATA AND SPECIFICATIONS (SDS) 17	Removal and Installation 32
Thermostat 17	Inspection 32
Radiator 17	

SERVICE DATA AND SPECIFICATIONS (SDS)	33
Thermostat	33
Radiator	33

PRECAUTIONS

Precautions for Supplemental Restraint System (SRS) “AIR BAG” and “SEAT BELT PRE-TENSIONER”

EBS00GV3

The Supplemental Restraint System such as “AIR BAG” and “SEAT BELT PRE-TENSIONER”, used along with a front seat belt, helps to reduce the risk or severity of injury to the driver and front passenger for certain types of collision. This system may include seat belt switch inputs and dual stage front air bag modules. If equipped with dual stage front air bag modules, the SRS system uses the seat belt switches to determine the front air bag deployment, and may only deploy one front air bag, depending on the severity of a collision and whether the front occupants are belted or unbelted. Information necessary to service the system safely is included in the SRS and SB section of this Service Manual.

The vehicle may be equipped with a passenger air bag deactivation switch. Because no rear seat exists where a rear-facing child restraint can be placed, the switch is designed to turn off the passenger air bag so that a rear-facing child restraint can be used in the front passenger seat. The switch is located in the center of the instrument panel, near the ashtray. When the switch is turned to the ON position, the passenger air bag is enabled and could inflate for certain types of collision. When the switch is turned to the OFF position, the passenger air bag is disabled and will not inflate. A passenger air bag OFF indicator on the instrument panel lights up when the passenger air bag is switched OFF. The driver air bag always remains enabled and is not affected by the passenger air bag deactivation switch.

WARNING:

- To avoid rendering the SRS inoperative, which could increase the risk of personal injury or death in the event of a collision which would result in air bag inflation, all maintenance must be performed by an authorized NISSAN/INFINITI dealer.
- Improper maintenance, including incorrect removal and installation of the SRS, can lead to personal injury caused by unintentional activation of the system. For removal of Spiral Cable and Air Bag Module, see the SRS section.
- Do not use electrical test equipment on any circuit related to the SRS unless instructed to in this Service Manual. SRS wiring harnesses can be identified by yellow and/or orange harnesses or harness connectors.
- The vehicle may be equipped with a passenger air bag deactivation switch which can be operated by the customer. When the passenger air bag is switched OFF, the passenger air bag is disabled and will not inflate. When the passenger air bag is switched ON, the passenger air bag is enabled and could inflate for certain types of collision. After SRS maintenance or repair, make sure the passenger air bag deactivation switch is in the same position (ON or OFF) as when the vehicle arrived for service.

**Precautions for Liquid Gasket
REMOVAL OF LIQUID GASKET**

EBS00GV4

- After removing the mounting bolts and nuts, separate the mating surface using a seal cutter and remove the sealant.

CAUTION:

Be careful not to damage the mating surfaces.

- In areas where the cutter is difficult to use, use a plastic hammer to lightly tap the areas where the sealant is applied.

CAUTION:

If for some unavoidable reason a tool such as a flat-bladed screwdriver is used, be careful not to damage the mating surfaces.

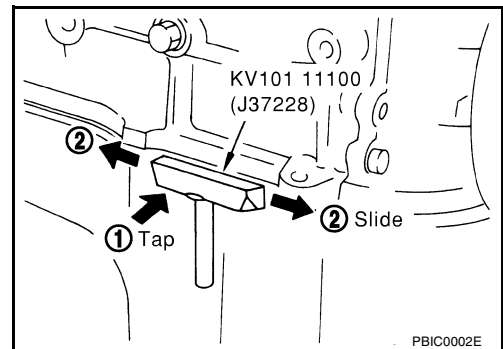

PRECAUTIONS

[KA24DE]

LIQUID GASKET APPLICATION PROCEDURE

1. Using a scraper, remove the old sealant adhering to the mating surface.
 - Remove the sealant completely from the groove, mounting bolts, and bolt holes.
2. Clean the mating surface thoroughly to remove adhering moisture, grease and foreign materials.
3. Install the sealant tube into the tube presser.
Use Genuine Silicone RTV or equivalent. Refer to [GI-42](#). "[RECOMMENDED CHEMICAL PRODUCTS AND SEALANTS](#)".

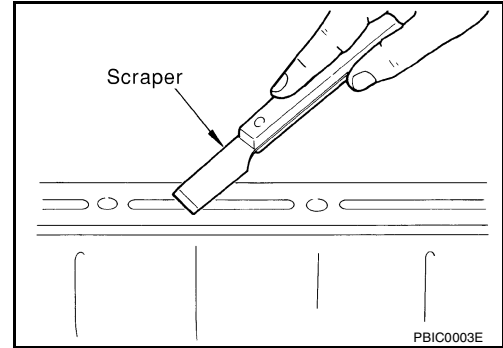

4. Apply the sealant without breaks to the specified area with the specified dimensions.
 - If there is a groove for the sealant application, apply the sealant to the groove.

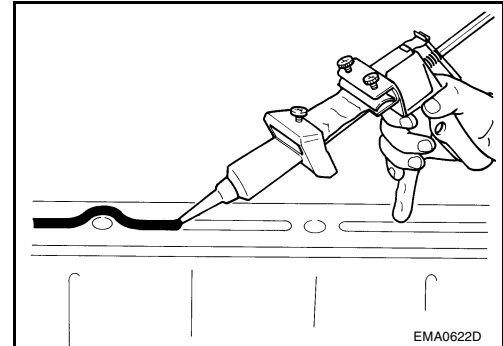

- As for the bolt holes, normally apply the sealant inside the holes. If specified, it should be applied outside the holes. Make sure to read the instructions in this manual.
- Within five minutes of sealant application, install the mating component.
- If the sealant protrudes, wipe it off immediately.
- Do not retighten after the installation.
- After 30 minutes or more have passed from the installation, fill the engine with the correct oil and coolant. Refer to [MA-12](#). "[Recommended Fluids and Lubricants](#)".

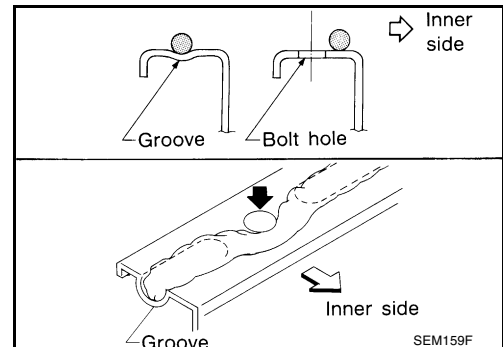

CAUTION:

If there are specific instructions in the service manual, observe them.

OVERHEATING CAUSE ANALYSIS

[KA24DE]

OVERHEATING CAUSE ANALYSIS

PFP:00012

Troubleshooting Chart

EBS00GV6

	Symptom		Check items	
Cooling system parts malfunction	Poor heat transfer	Water pump malfunction	Worn or loose drive belt	—
		Thermostat stuck closed	Coolant circulation	
		Damaged fins	Dust contamination or rock clogging	
			Mechanical damage	
		Clogged radiator cooling tube	Excess foreign material (rust, dirt, sand, etc.)	
	Reduced air flow	Fan coupling does not operate	Fan and coupling	—
		High resistance to fan rotation		
		Damaged fan blades		
	Damaged radiator shroud	—	—	—
	Improper coolant mixture ratio	—	—	—
	Poor coolant quality	—	Periodic maintenance	—
	Insufficient coolant	Coolant leaks	Cooling hose	Loose clamp
				Cracked hose
			Water pump	Poor sealing
				Radiator cap
Poor sealing				
Radiator			O-ring for damage, deterioration or improper fitting	
		Cracked radiator tank		
Reservoir tank		Cracked radiator core		
	Cracked reservoir tank			
Overflowing reservoir tank	Exhaust gas leaks into cooling system	Cylinder head deterioration		
		Cylinder head gasket deterioration		
	Abusive driving	High engine rpm under no load		
		Driving in low gear for extended time		
		Driving at extremely high speed		
		Powertrain system malfunction	—	
				Installed improper size wheels and tires
				Dragging brakes
Improper ignition timing				
Blocked or restricted air flow	Blocked radiator grille	Installed car brassiere	—	
	Blocked bumper	Mud contamination or paper clogging		
	Blocked radiator			
	Blocked condenser			
	Installed large fog lamp			

COOLING SYSTEM

[KA24DE]

PFP:21020

EBS00GV7

COOLING SYSTEM

Cooling Circuit

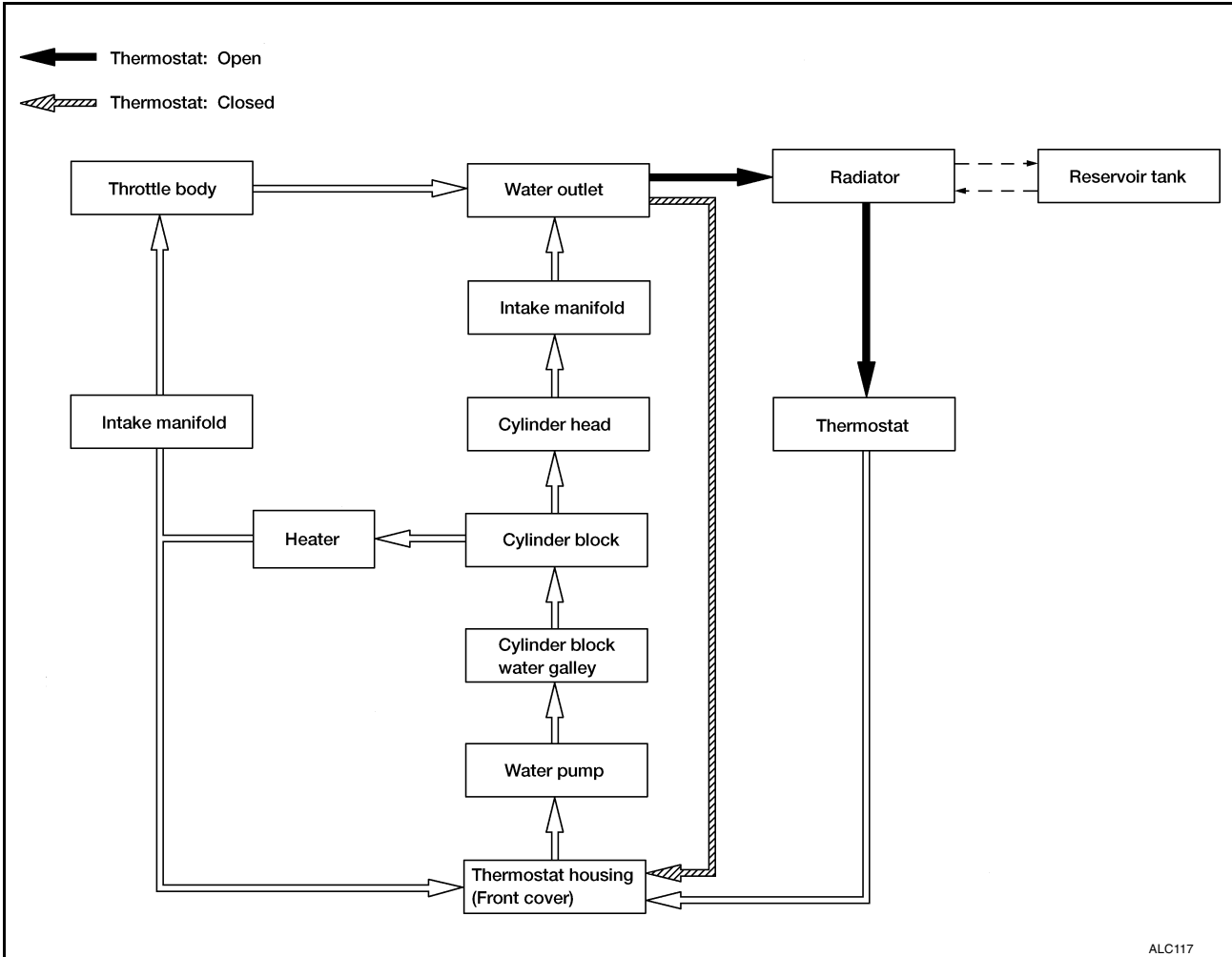

A

CO

C

D

E

F

G

H

I

J

K

L

M

ENGINE COOLANT

System Check

WARNING:

- Never remove the radiator cap when the engine is hot. Serious burns could occur from high pressure coolant escaping from the radiator.
- Wrap a thick cloth around the radiator cap. Slowly turn it a quarter turn to allow built-up pressure to escape. Carefully remove the radiator cap by turning it all the way.

CHECKING COOLING SYSTEM HOSES

- Check hoses for improper attachment, leaks, cracks, damage, chafing and deterioration.

CHECKING RADIATOR

Check radiator for mud or clogging. If necessary, clean radiator as follows:

CAUTION:

- Be careful not to bend or damage the radiator fins.
 - When radiator is cleaned without removal, remove all surrounding parts such as cooling fan, radiator shroud and horns.
 - Tape the harness connectors to prevent water from entering.
1. Apply water by hose to the back side of the radiator core vertically downward.
 2. Apply water again to all radiator core surfaces once per minute.
 3. Stop washing when water flows clear coming out of the radiator.
 4. Blow air into the back side of radiator core vertically downward.
 - Use compressed air lower than 490 kPa (5 kg/cm², 71 psi) and keep the air hose end more than 30 cm (11.8 in) away from the core.
 5. Blow air again into all the radiator core surfaces once per minute until no water blows out and the core is dry.

CHECKING COOLING SYSTEM FOR LEAKS

- To check for leakage, apply pressure to the cooling system with a radiator cap tester.

CAUTION:

Higher pressure than specified may cause radiator damage.

Testing pressure : 157 kPa (1.6 kg/cm², 23 psi)

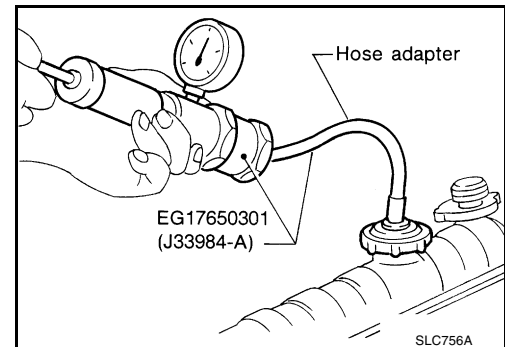

CHECKING RADIATOR CAP

- To check radiator cap, apply pressure to radiator cap with a radiator cap tester.

Radiator cap relief pressure

Standard : 78 - 98 kPa (0.8 - 1.0 kg/cm², 11 - 14 psi)

Limit : 59 kPa (0.6 kg/cm², 9 psi)

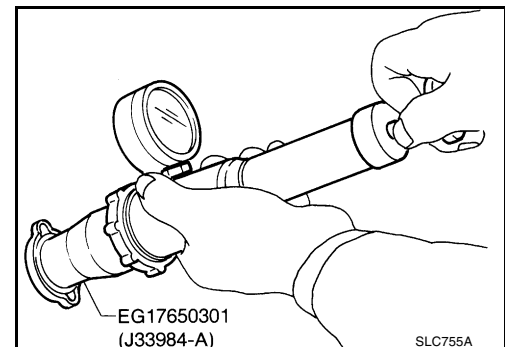

- Pull the negative pressure valve to open it.
Check that it closes completely when released.

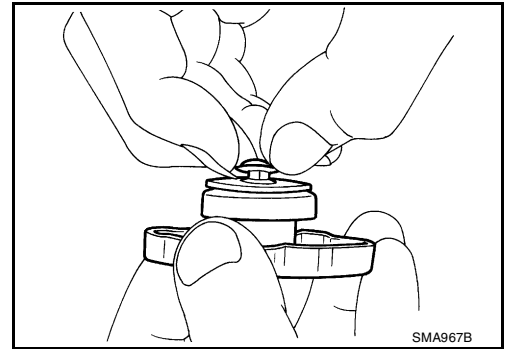

EBS00GV9

Refilling Engine Coolant

For details on refilling the engine cooling system, refer to [MA-17, "REFILLING ENGINE COOLANT"](#).

A
CO
C
D
E
F
G
H
I
J
K
L
M

WATER PUMP

Removal

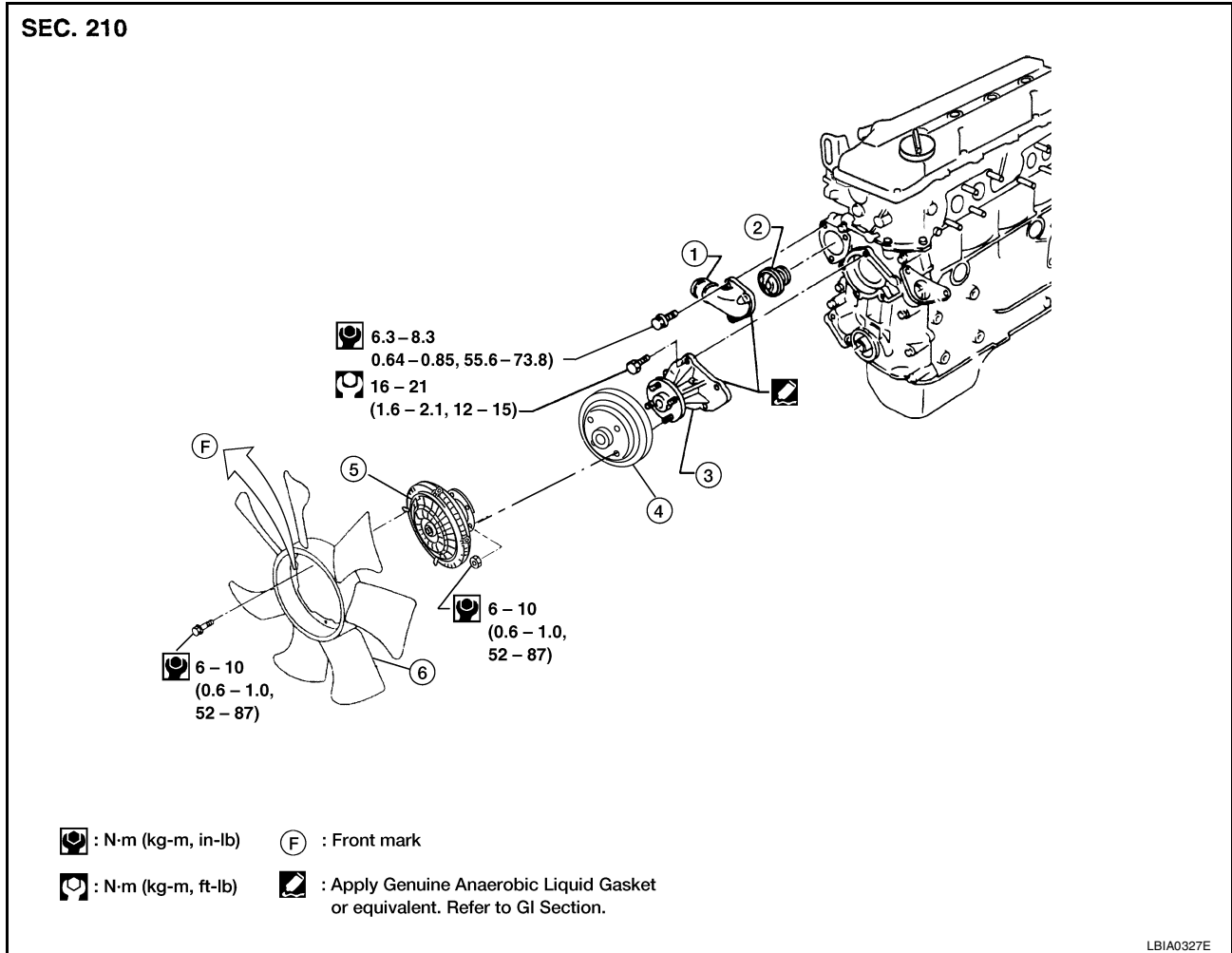

- | | | |
|----------------------|-----------------|---------------|
| 1. Water inlet | 2. Thermostat | 3. Water pump |
| 4. Water pump pulley | 5. Fan coupling | 6. Fan |

CAUTION:

- When removing water pump assembly, be careful not to get coolant on drive belts.
 - Water pump cannot be disassembled and should be replaced as a unit.
 - After installing water pump, connect hose and clamp securely. Check for leaks using radiator cap tester.
1. Drain coolant from engine.
Refer to [MA-16, "DRAINING ENGINE COOLANT"](#).
 2. Remove fan coupling with fan.
 3. Remove power steering pump drive belt, generator drive belt, and A/C compressor drive belt.
 4. Remove water pump pulley.
 5. Remove water pump.

EBS00GVB

Inspection

- Check body assembly for rust or corrosion.
- Check for rough operation due to excessive end play.

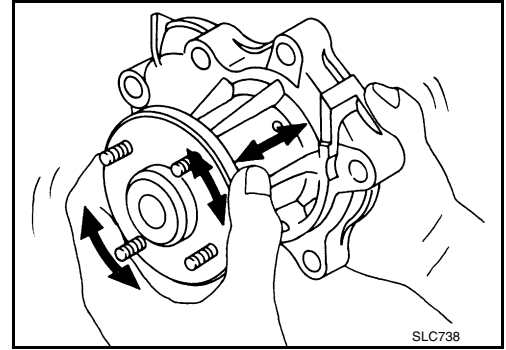

Installation

1. Use a scraper to remove liquid gasket from water pump.
 - Also remove traces of liquid gasket from mating surface of cylinder block.

EBS00GVC

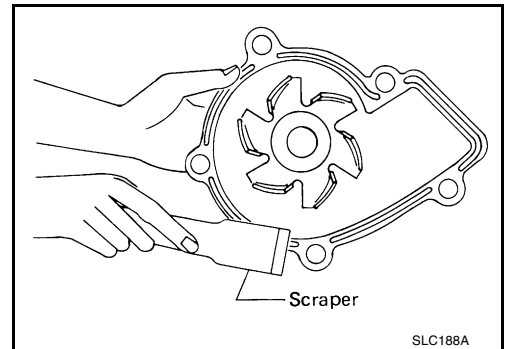

2. Apply a continuous bead of liquid gasket to mating surface of water pump.
 - Use **Genuine Anaerobic Liquid Gasket or equivalent.** Refer to [GI-42, "RECOMMENDED CHEMICAL PRODUCTS AND SEALANTS"](#).

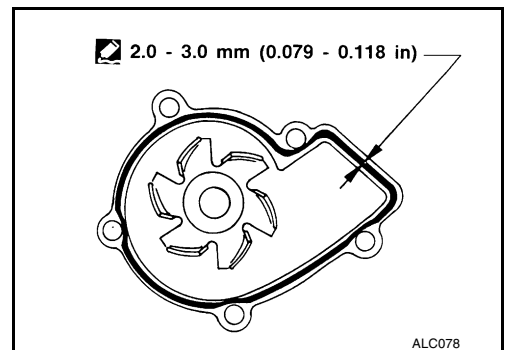

3. Install water pump. Tighten water pump bolts to specification as shown.

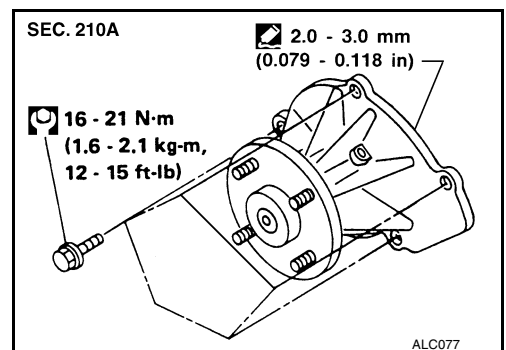

4. Install water pump pulley.
5. Install power steering pump drive belt, generator drive belt, and A/C compressor drive belt. Refer to [MA-15, "Checking Drive Belts"](#).

THERMOSTAT

Removal

- **Be careful not to spill coolant over engine compartment. Use a rag to absorb coolant.**
1. Drain coolant from engine. Refer to [MA-16, "DRAINING ENGINE COOLANT"](#).
 2. Remove air cleaner and air duct assembly.
 3. Remove water hose from water inlet housing.
 4. Remove water inlet housing, then take out thermostat.

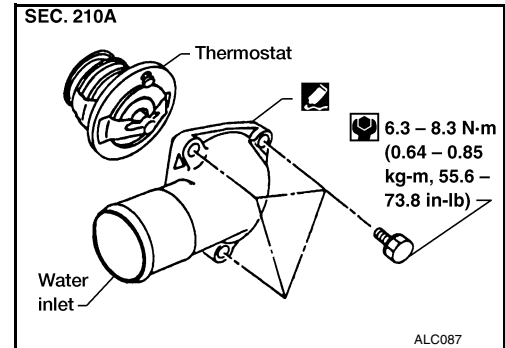

Inspection

1. Check valve seating condition at normal room temperature. It should seat tightly.
2. Check valve opening temperature and valve lift.

Valve opening temperature	76.5°C (170°F)
Valve lift	More than 8 mm/90°C (0.31 in/194°F)

3. Check if valve closes at 5°C (9°F) below valve opening temperature.

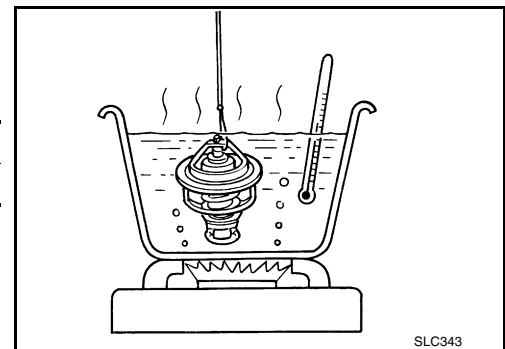

Installation

1. Use a scraper to remove old liquid gasket from water inlet.
 - **Also remove traces of liquid gasket from mating surface of front cover.**
2. Apply a continuous bead of liquid gasket to mating surface of water inlet.
 - **Use Genuine Anaerobic Liquid Gasket or equivalent. Refer to [GI-42, "RECOMMENDED CHEMICAL PRODUCTS AND SEALANTS"](#).**

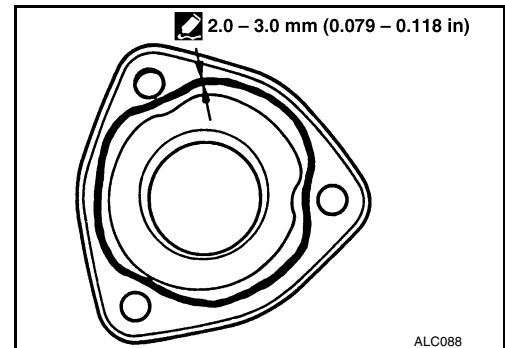

3. Install thermostat with jiggle valve or air bleeder at upper side.
4. Install water inlet housing.
5. Install water hose to water inlet housing.
6. Install air cleaner and air duct assembly.
7. Refill engine cooling system. Refer to [MA-17, "REFILLING ENGINE COOLANT"](#).
 - **After installation, run engine for a few minutes and check for leaks.**

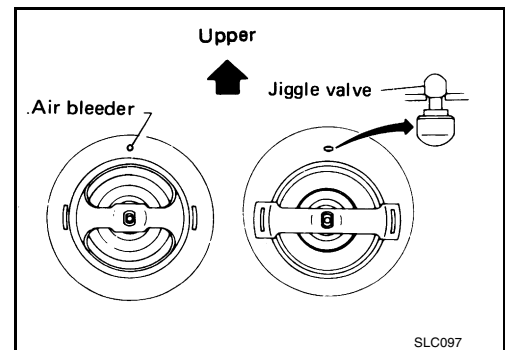

RADIATOR

Components

SEC. 214

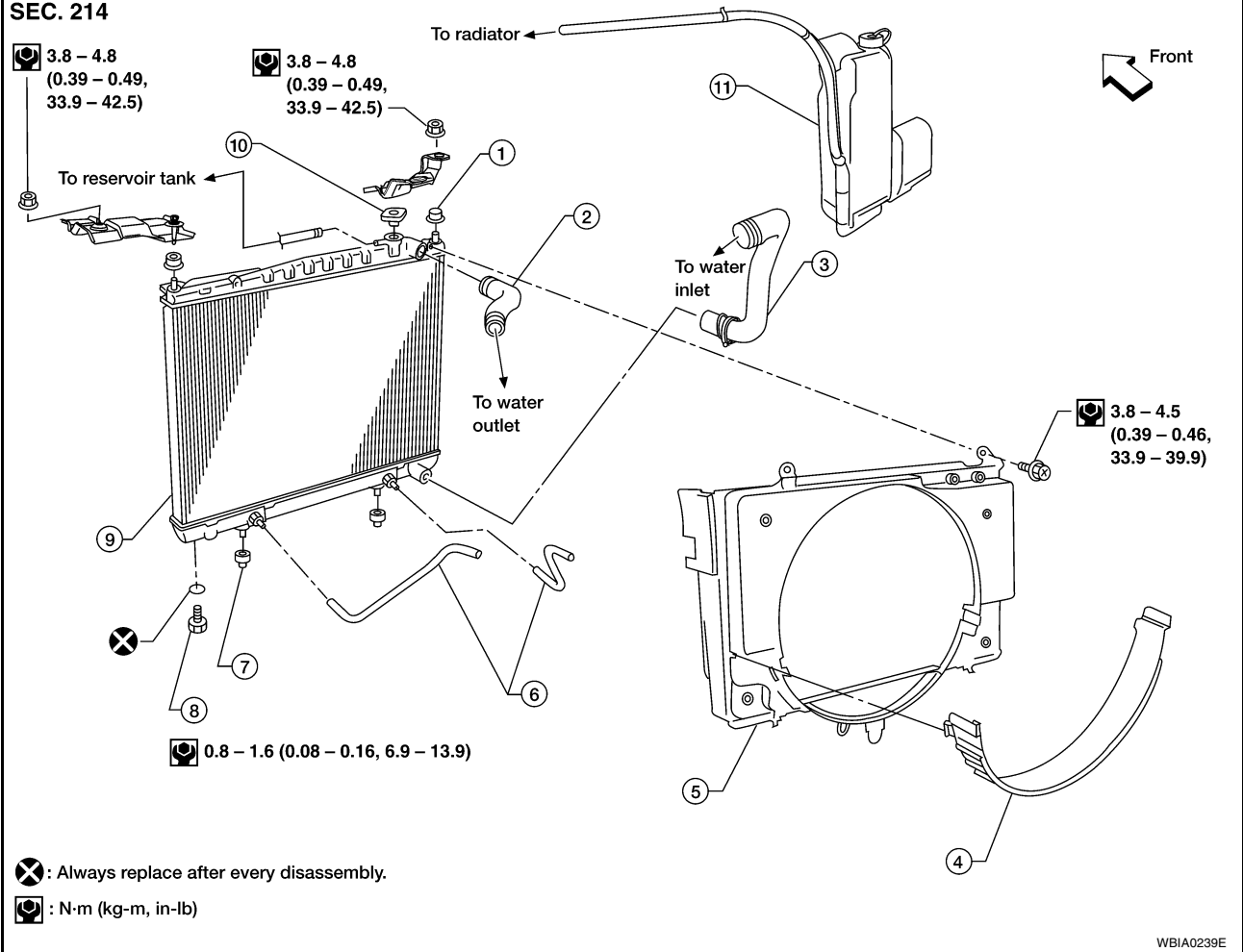

- | | | |
|--------------------------|--------------------------|-------------------------|
| 1. Mounting rubber | 2. Radiator upper hose | 3. Radiator lower hose |
| 4. Radiator lower shroud | 5. Radiator upper shroud | 6. A/T oil cooler hoses |
| 7. Mounting rubber | 8. Radiator drain plug | 9. Radiator |
| 10. Radiator filler cap | 11. Radiator reservoir | |

Removal and Installation

1. Remove undercover.
2. Drain coolant from radiator. Refer to [MA-16, "DRAINING ENGINE COOLANT"](#).
3. Disconnect upper and lower radiator hoses.
4. Remove air cleaner and air duct assembly.
5. Remove lower radiator shroud.
6. Remove radiator shroud.
7. Remove A/T oil cooler hoses (A/T models only).
8. Disconnect coolant reservoir hose.
9. Remove radiator.
10. After replacing radiator, install all parts in reverse order of removal.
11. Refill engine coolant. Refer to [MA-17, "REFILLING ENGINE COOLANT"](#).
 - After installation, run engine for a few minutes, and check for leaks.

RADIATOR

[KA24DE]

EBS00GV1

Inspection

1. Apply pressure with Tool.

Specified pressure value : 157 kPa (1.6 kg/cm² , 23 psi)

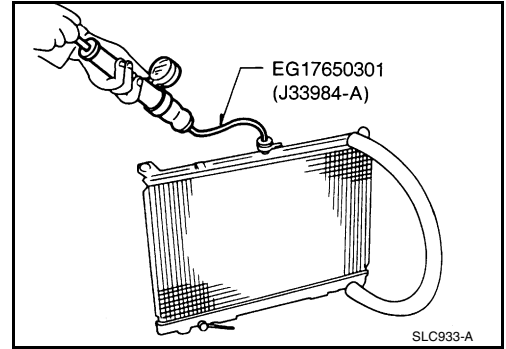

2. Check radiator for leaks in water tank by looking for bubbles.

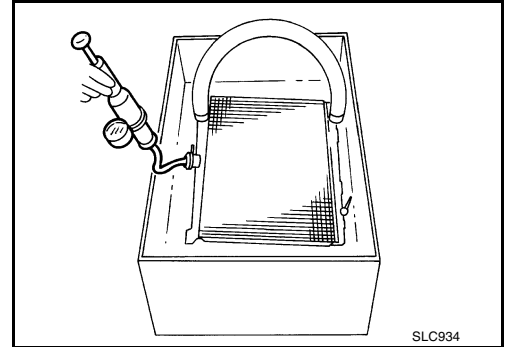

A
CO
C
D
E
F
G
H
I
J
K
L
M

COOLING FAN (CRANKSHAFT DRIVEN)

PFP:21060

Removal and Installation

EBS00GVJ

- Do not release the drive belt tension by removing the fan/water pump pulley.
- Fan coupling cannot be disassembled and should be replaced as a unit. If front mark **F** is present, install fan so that side marked **F** faces the front.
- Install the drive belt only after the fan and fan coupling to water pump flange bolts/nuts have been properly tightened.
- Proper alignment of these components is essential. Improper alignment will cause them to wobble and may eventually cause the fan to separate from the water pump, causing extensive damage.

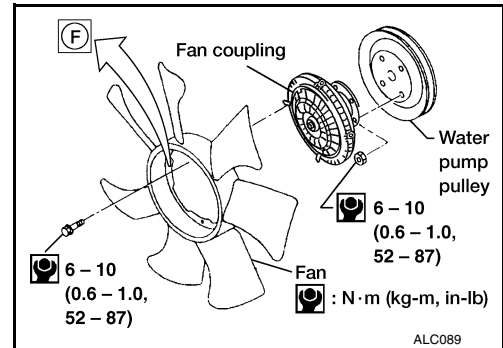

Inspection

EBS00GVK

WARNING:

When the engine is running, keep hands and clothing away from moving parts such as drive belts and fan.

- Check fan coupling for rough operation, wobbling, oil leakage or bent bimetal fins.

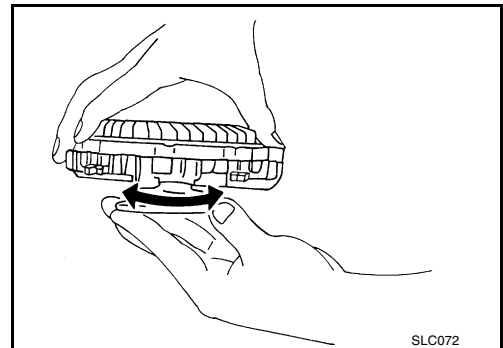

- After assembly, verify the fan does not wobble or flap while the engine is running.

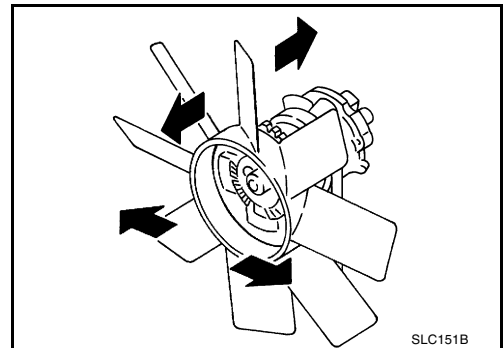

SERVICE DATA AND SPECIFICATIONS (SDS)

[KA24DE]

SERVICE DATA AND SPECIFICATIONS (SDS)

PF0:00030

Thermostat

EBS00GVL

Valve opening temperature	76.5°C (170°F)
Valve lift	More than 8 mm/90°C (0.31 in/194°F)

Radiator

EBS00GVM

Unit: kPa (kg/cm², psi)

Cap relief pressure	Standard	78 - 98 (0.8 - 1.0, 11 - 14)
	Limit	59 (0.6, 9)
Leakage test pressure		157 (1.6, 23)

A
CO
C
D
E
F
G
H
I
J
K
L
M

PRECAUTIONS

PF0:00001

Precautions for Supplemental Restraint System (SRS) “AIR BAG” and “SEAT BELT PRE-TENSIONER”

EBS00GVN

The Supplemental Restraint System such as “AIR BAG” and “SEAT BELT PRE-TENSIONER”, used along with a front seat belt, helps to reduce the risk or severity of injury to the driver and front passenger for certain types of collision. This system may include seat belt switch inputs and dual stage front air bag modules. If equipped with dual stage front air bag modules, the SRS system uses the seat belt switches to determine the front air bag deployment, and may only deploy one front air bag, depending on the severity of a collision and whether the front occupants are belted or unbelted. Information necessary to service the system safely is included in the SRS and SB section of this Service Manual.

The vehicle may be equipped with a passenger air bag deactivation switch. Because no rear seat exists where a rear-facing child restraint can be placed, the switch is designed to turn off the passenger air bag so that a rear-facing child restraint can be used in the front passenger seat. The switch is located in the center of the instrument panel, near the ashtray. When the switch is turned to the ON position, the passenger air bag is enabled and could inflate for certain types of collision. When the switch is turned to the OFF position, the passenger air bag is disabled and will not inflate. A passenger air bag OFF indicator on the instrument panel lights up when the passenger air bag is switched OFF. The driver air bag always remains enabled and is not affected by the passenger air bag deactivation switch.

WARNING:

- To avoid rendering the SRS inoperative, which could increase the risk of personal injury or death in the event of a collision which would result in air bag inflation, all maintenance must be performed by an authorized NISSAN/INFINITI dealer.
- Improper maintenance, including incorrect removal and installation of the SRS, can lead to personal injury caused by unintentional activation of the system. For removal of Spiral Cable and Air Bag Module, see the SRS section.
- Do not use electrical test equipment on any circuit related to the SRS unless instructed to in this Service Manual. SRS wiring harnesses can be identified by yellow and/or orange harnesses or harness connectors.
- The vehicle may be equipped with a passenger air bag deactivation switch which can be operated by the customer. When the passenger air bag is switched OFF, the passenger air bag is disabled and will not inflate. When the passenger air bag is switched ON, the passenger air bag is enabled and could inflate for certain types of collision. After SRS maintenance or repair, make sure the passenger air bag deactivation switch is in the same position (ON or OFF) as when the vehicle arrived for service.

Precautions for Liquid Gasket REMOVAL OF LIQUID GASKET

EBS00GVO

- After removing the mounting bolts and nuts, separate the mating surface using a seal cutter and remove the sealant.

CAUTION:

Be careful not to damage the mating surfaces.

- In areas where the cutter is difficult to use, use a plastic hammer to lightly tap the areas where the sealant is applied.

CAUTION:

If for some unavoidable reason a tool such as a flat-bladed screwdriver is used, be careful not to damage the mating surfaces.

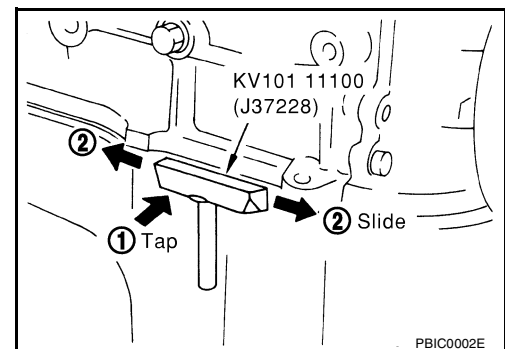

PRECAUTIONS

[VG33E and VG33ER]

EBS00GVP

Precautions for Liquid Gasket REMOVAL OF LIQUID GASKET

- After removing the mounting bolts and nuts, separate the mating surface using a seal cutter and remove the sealant.

CAUTION:

Be careful not to damage the mating surfaces.

- In areas where the cutter is difficult to use, use a plastic hammer to lightly tap the areas where the sealant is applied.

CAUTION:

If for some unavoidable reason a tool such as a flat-bladed screwdriver is used, be careful not to damage the mating surfaces.

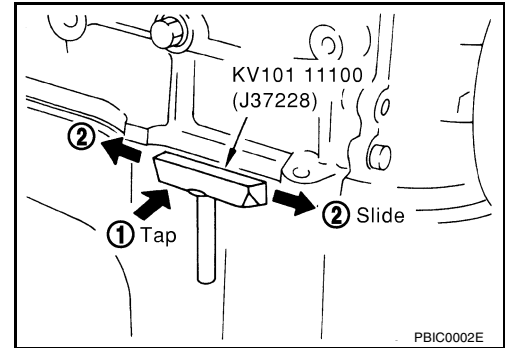

LIQUID GASKET APPLICATION PROCEDURE

1. Using a scraper, remove the old sealant adhering to the mating surface.
 - Remove the sealant completely from the groove, mounting bolts, and bolt holes.
2. Clean the mating surface thoroughly to remove adhering moisture, grease and foreign materials.
3. Install the sealant tube into the tube presser.
Use Genuine Silicone RTV or equivalent. Refer to [GI-42, "RECOMMENDED CHEMICAL PRODUCTS AND SEALANTS"](#).
4. Apply the sealant without breaks to the specified area with the specified dimensions.
 - If there is a groove for the sealant application, apply the sealant to the groove.

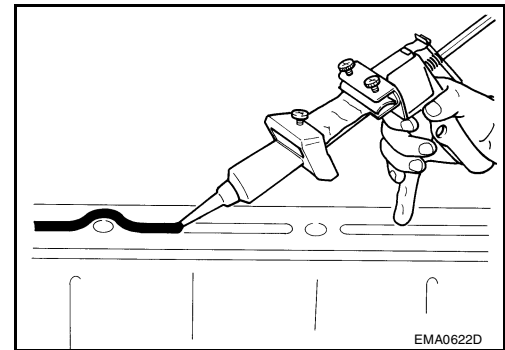
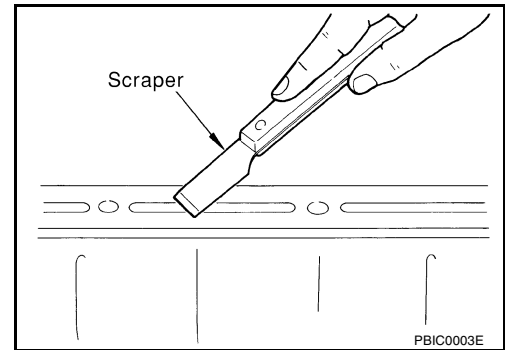

- As for the bolt holes, normally apply the sealant inside the holes. If specified, it should be applied outside the holes. Make sure to read the instructions in this manual.
- Within five minutes of sealant application, install the mating component.
- If the sealant protrudes, wipe it off immediately.
- Do not retighten after the installation.
- After 30 minutes or more have passed from the installation, fill the engine with the correct oil and coolant. Refer to [MA-12, "Recommended Fluids and Lubricants"](#).

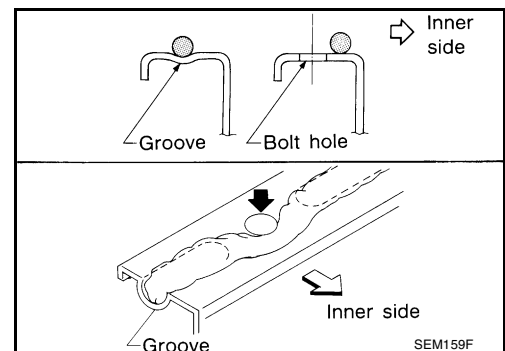

CAUTION:

If there are specific instructions in the service manual, observe them.

PREPARATION

Special Service Tools

The actual shapes of Kent-Moore tools may differ from those of special service tools illustrated here.

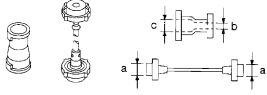
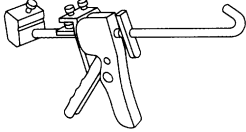
Tool number (Kent-Moore No.) Tool name	Description
EG17650301 (J33984-A) Radiator cap tester adapter	 <p style="text-align: center;">NT564</p> Adapting radiator cap tester to radiator filler neck a: 28 (1.10) dia. b: 31.4 (1.236) dia. c: 41.3 (1.626) dia. Unit: mm (in)
WS39930000 (—) Tube presser	 <p style="text-align: center;">NT052</p> Pressing the tube of liquid gasket

OVERHEATING CAUSE ANALYSIS

[VG33E and VG33ER]

OVERHEATING CAUSE ANALYSIS

PFP:00012

Troubleshooting Chart

EBS00GVR

	Symptom		Check items		
Cooling system parts malfunction	Poor heat transfer	Water pump malfunction	Worn or loose drive belt	—	CO
		Thermostat stuck closed	Coolant circulation		
		Damaged fins	Dust contamination or rock clogging		
			Mechanical damage		
	Reduced air flow	Fan coupling does not operate	Fans and coupling	—	C
		High resistance to fan rotation			
		Damaged fan blades			
	Damaged radiator shroud	—	—	—	D
	Improper coolant mixture ratio	—	—	—	E
	Poor coolant quality	—	Periodic maintenance	—	F
	Insufficient coolant	Coolant leaks	Cooling hose	Loose clamp	H
				Cracked hose	
			Water pump	Poor sealing	
				Radiator cap	Loose
		Poor sealing			
Radiator		O-ring for damage, deterioration or improper fitting	J		
		Cracked radiator tank			
		Cracked radiator core			
Reservoir tank	Cracked reservoir tank	K			
Overflowing reservoir tank	Exhaust gas leaks into cooling system	Cylinder head deterioration	L		
		Cylinder head gasket deterioration			
Except cooling system parts malfunction	—	Overload on engine	Abusive driving	High engine rpm under no load	M
				Driving in low gear for extended time	
				Driving at extremely high speed	
		Powertrain system malfunction	—		
	Installed improper size wheels and tires				
	Dragging brakes				
	Improper ignition timing				
	Blocked or restricted air flow	Blocked radiator grille	Installed car brassiere	—	
Blocked bumper		Mud contamination or paper clogging			
Blocked radiator					
Blocked condenser					
Installed large fog lamp					

COOLING SYSTEM

[VG33E and VG33ER]

COOLING SYSTEM

PFP:21020

Cooling Circuit

EBS00GVS

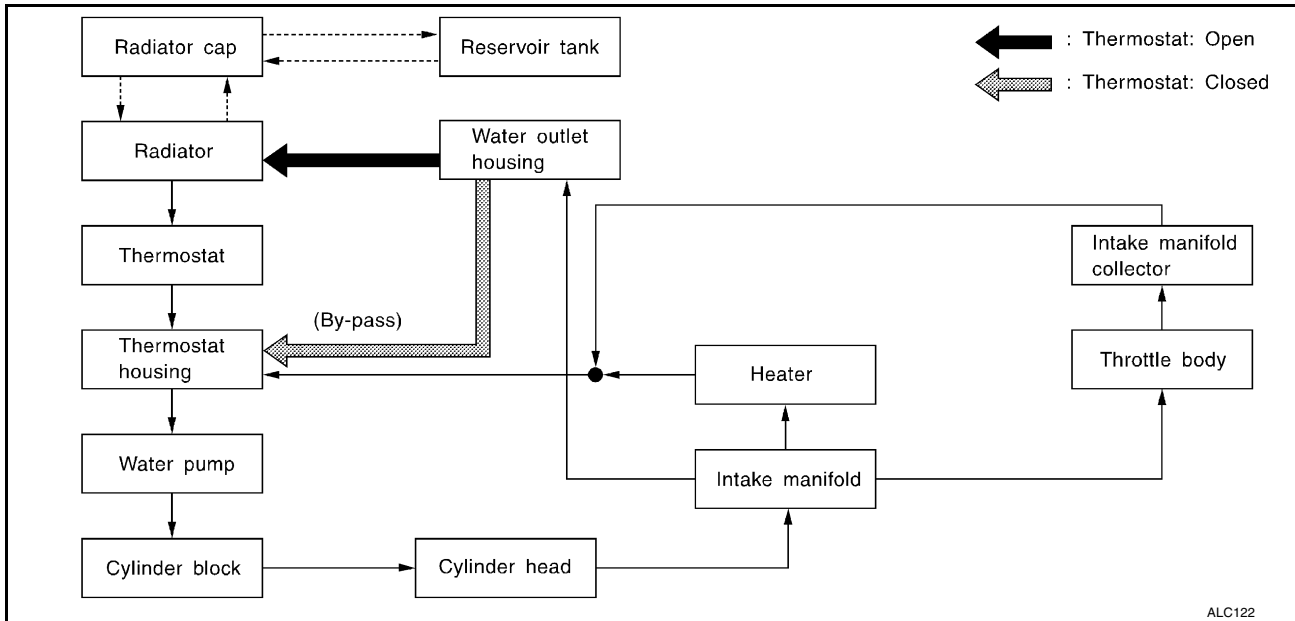

ENGINE COOLANT

System Check

WARNING:

- Never remove the radiator cap when the engine is hot. Serious burns could occur from high pressure coolant escaping from the radiator.
- Wrap a thick cloth around the cap. Slowly turn it a quarter turn to allow built-up pressure to escape. Carefully remove the cap by turning it all the way.

CHECKING COOLING SYSTEM HOSES

Check hoses for improper attachment, leaks, cracks, damage, loose connections, chafing and deterioration.

CHECKING RADIATOR

Check radiator for mud or clogging. If necessary, clean radiator as follows:

CAUTION:

- Be careful not to bend or damage the radiator fins.
 - When radiator is cleaned without removal, remove all surrounding parts such as cooling fan, radiator shroud and horns.
 - Tape the harness connectors to prevent water from entering.
1. Apply water by hose to the back side of the radiator core vertically downward.
 2. Apply water again to all radiator core surfaces once per minute.
 3. Stop washing when water flows clear coming out from the radiator.
 4. Blow air into the back side of radiator core vertically downward.
 - Use compressed air lower than 490 kPa (5 kg/cm², 71 psi) and keep the air hose end more than 30 cm (11.8 in) away from the core.
 5. Blow air again into all the radiator core surfaces once per minute until no water blows out and the core is dry.

CHECKING COOLING SYSTEM FOR LEAKS

- To check for leakage, apply pressure to the cooling system with a radiator cap tester.

CAUTION:

Higher pressure than specified may cause radiator damage.

Testing pressure : 157 kPa (1.6 kg/cm², 23 psi)

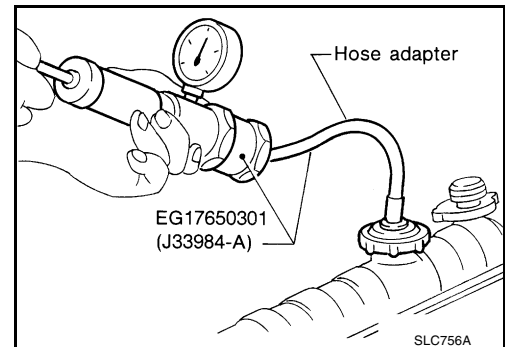

CHECKING RADIATOR CAP

- To check radiator cap, apply pressure to cap with a radiator cap tester.

Radiator cap relief pressure

Standard : 78 - 98 kPa (0.8 - 1.0 kg/cm², 11 - 14 psi)

Limit : 59 kPa (0.6 kg/cm², 9 psi)

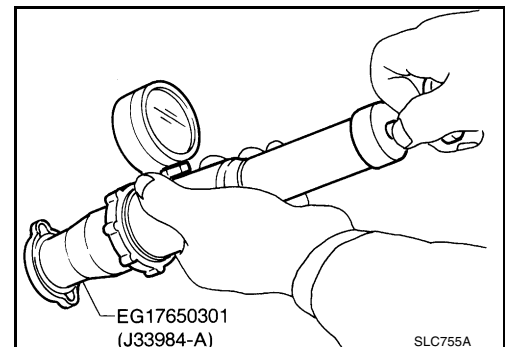

ENGINE COOLANT

[VG33E and VG33ER]

- Pull the negative pressure valve to open it.
Check that it closes completely when released.

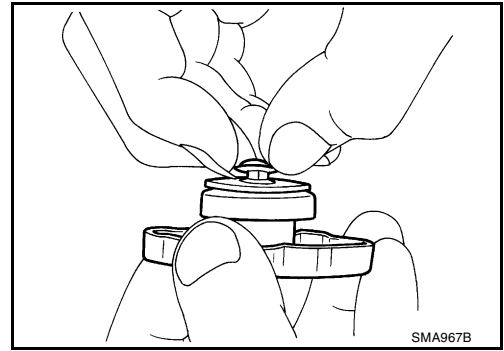

Refilling Engine Coolant

EBS00GVU

For details on refilling the engine cooling system, refer to [MA-26, "REFILLING ENGINE COOLANT"](#) .

WATER PUMP

PFP:21020

Removal

EBS00GVV

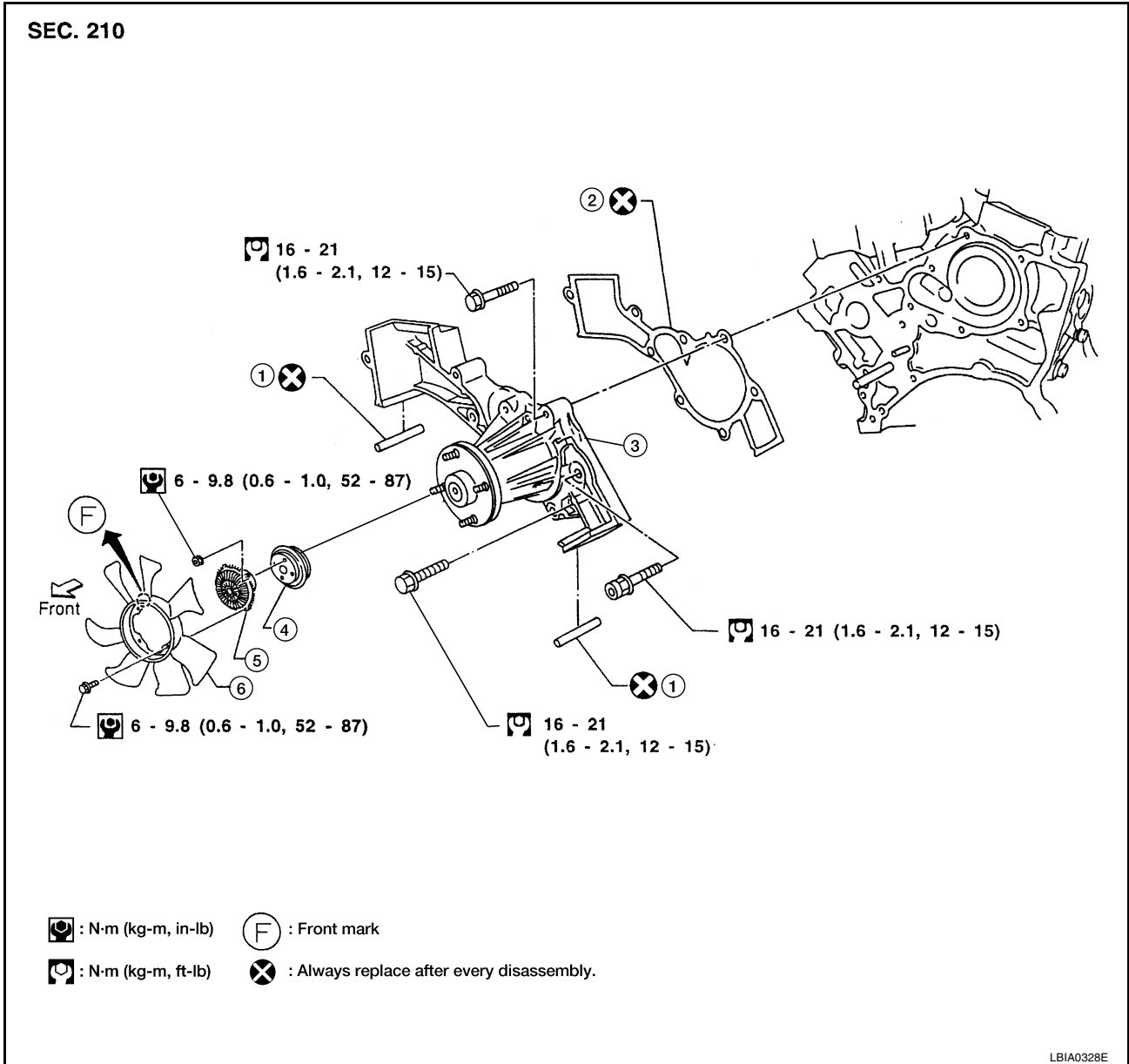

- | | | |
|----------------------|-----------------|----------------|
| 1. Rubber seal | 2. Gasket | 3. Water pump |
| 4. Water pump pulley | 5. Fan coupling | 6. Cooling fan |

CAUTION:

- When removing water pump assembly, be careful not to get coolant on timing belt.
- Water pump cannot be disassembled and should be replaced as a unit.
- After installing water pump, connect hose and clamp securely, then check for leaks using radiator cap tester.
- To avoid deforming timing cover, make sure there is adequate clearance between it and the hose clamp.

WATER PUMP

[VG33E and VG33ER]

1. Drain coolant from drain plugs on both sides of cylinder block and radiator. Refer to [MA-26, "DRAINING ENGINE COOLANT"](#)

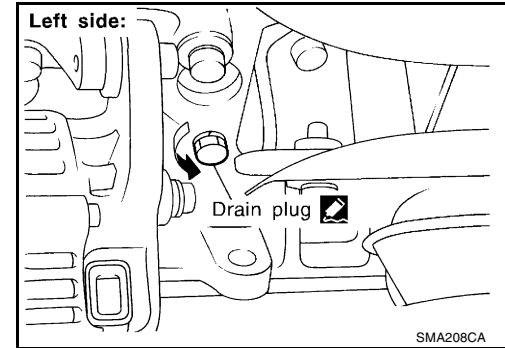
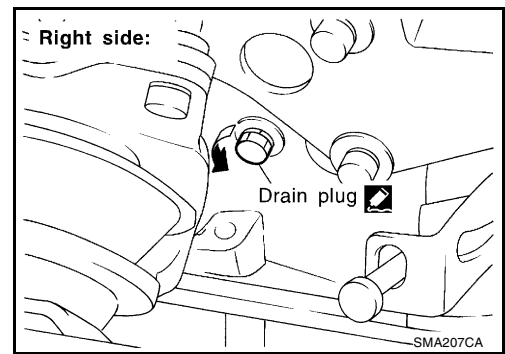

2. Remove radiator hoses (upper and lower) and fan shroud. Refer to [CO-30, "RADIATOR"](#) .
3. Remove fan coupling with fan.
4. Remove drive belts. Refer to [MA-24, "Checking Drive Belts"](#) .
5. Remove water pump pulley.
6. Remove crankshaft pulley and front (upper and lower) belt cover. Refer to [EM-91, "TIMING BELT"](#) .
7. Remove water pump.

Inspection

1. Check for badly rusted or corroded body assembly and vanes.
2. Check for rough operation due to excessive end play.

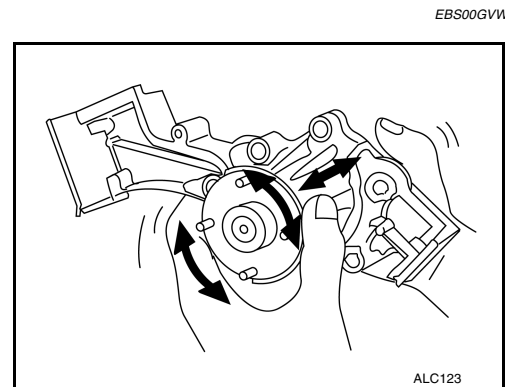

Installation

1. Use a scraper to remove liquid gasket from water pump.
 - Also remove traces of liquid gasket from mating surface of cylinder block.

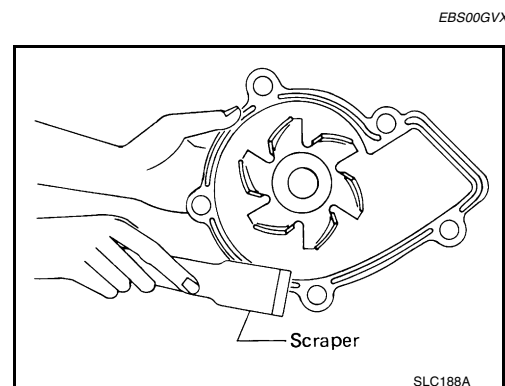

WATER PUMP

[VG33E and VG33ER]

2. Apply a continuous bead of liquid gasket to mating surface of water pump.
 - Use Genuine Anaerobic Liquid Gasket or equivalent. Refer to [GI-42, "RECOMMENDED CHEMICAL PRODUCTS AND SEALANTS"](#).

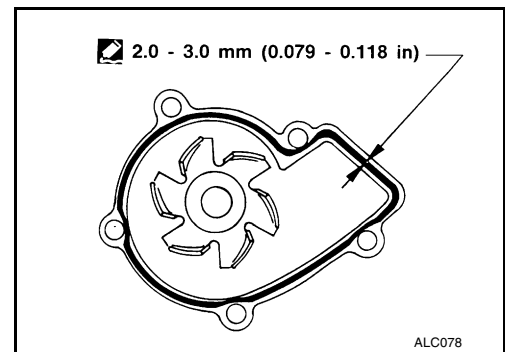

3. Installation is in the reverse order of removal.
 - When filling the radiator with coolant, refer to [MA-26, "REFILLING ENGINE COOLANT"](#).
 - When installing the drive belts, refer to [MA-24, "Checking Drive Belts"](#).

A

CO

C

D

E

F

G

H

I

J

K

L

M

THERMOSTAT

PFP:21200

Removal

EBS00GVY

- **Be careful not to spill coolant over engine compartment. Use a rag to absorb coolant.**
- 1. Drain engine coolant. Refer to [MA-26, "DRAINING ENGINE COOLANT"](#) .
- 2. Remove radiator hoses (upper and lower) and fan shroud.
- 3. Remove drive belts and pulley bracket.
- 4. Remove water inlet and thermostat assembly.

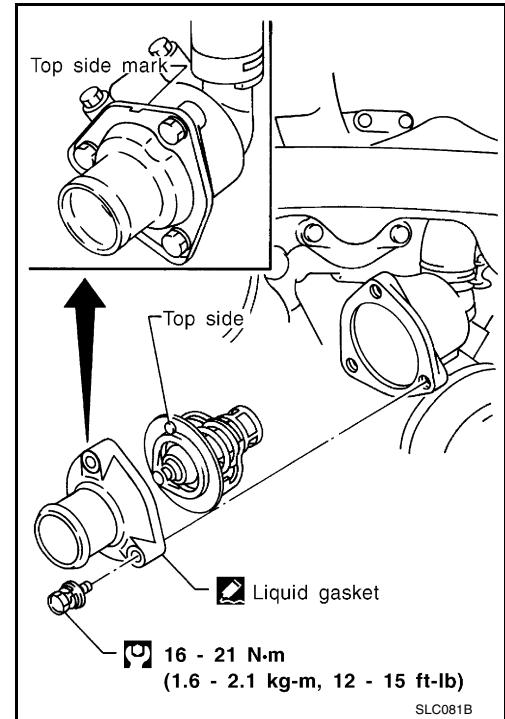

Inspection

EBS00GVZ

1. Check the thermostat valve seating condition at ordinary room temperature. The valve should seat tightly.
2. Check valve opening temperature and valve lift.

Description	VG33E	VG33ER
Valve opening temperature °C (°F)	82 (180)	76.5 (170)
Valve lift mm/°C (in/°F)	More than 10/95 (0.39/203)	More than 8 mm/90°C (0.31 in/194°F)

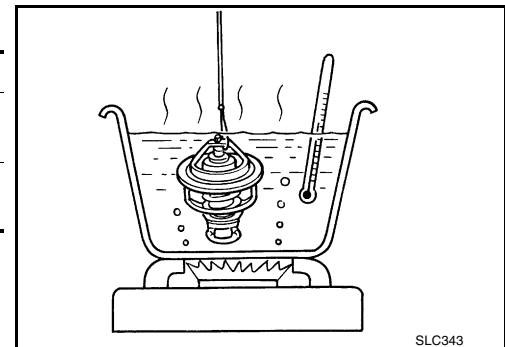

3. Check if valve closes at 5°C (9°F) below valve opening temperature.

THERMOSTAT

[VG33E and VG33ER]

EBS00GW0

Installation

1. Use a scraper to remove old liquid gasket from water inlet and engine mating surfaces.
2. Apply a continuous bead of liquid gasket to mating surface of water inlet.

- Use Genuine Anaerobic Liquid Gasket or equivalent. Refer to [GI-42, "RECOMMENDED CHEMICAL PRODUCTS AND SEALANTS"](#).

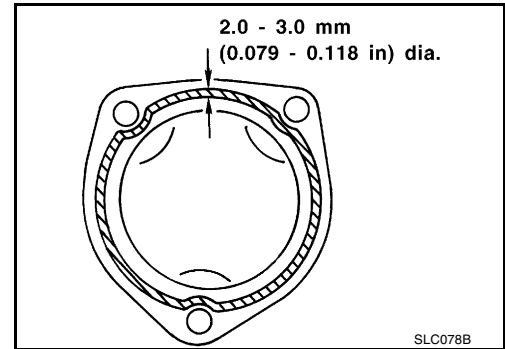

3. Install thermostat with jiggle valve or air bleeder at upper side.
 4. Install water inlet housing.
 5. Install pulley bracket and drive belts.
 6. Install radiator hoses (upper and lower) and fan shroud.
 7. Refill engine coolant. Refer to [MA-26, "REFILLING ENGINE COOLANT"](#).
- After installation, run engine for a few minutes, and check for leaks.

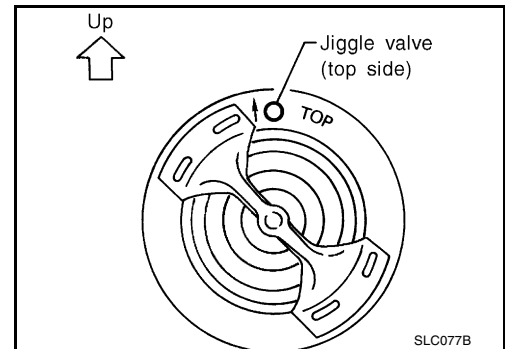

A
CO
C
D
E
F
G
H
I
J
K
L
M

RADIATOR

Components

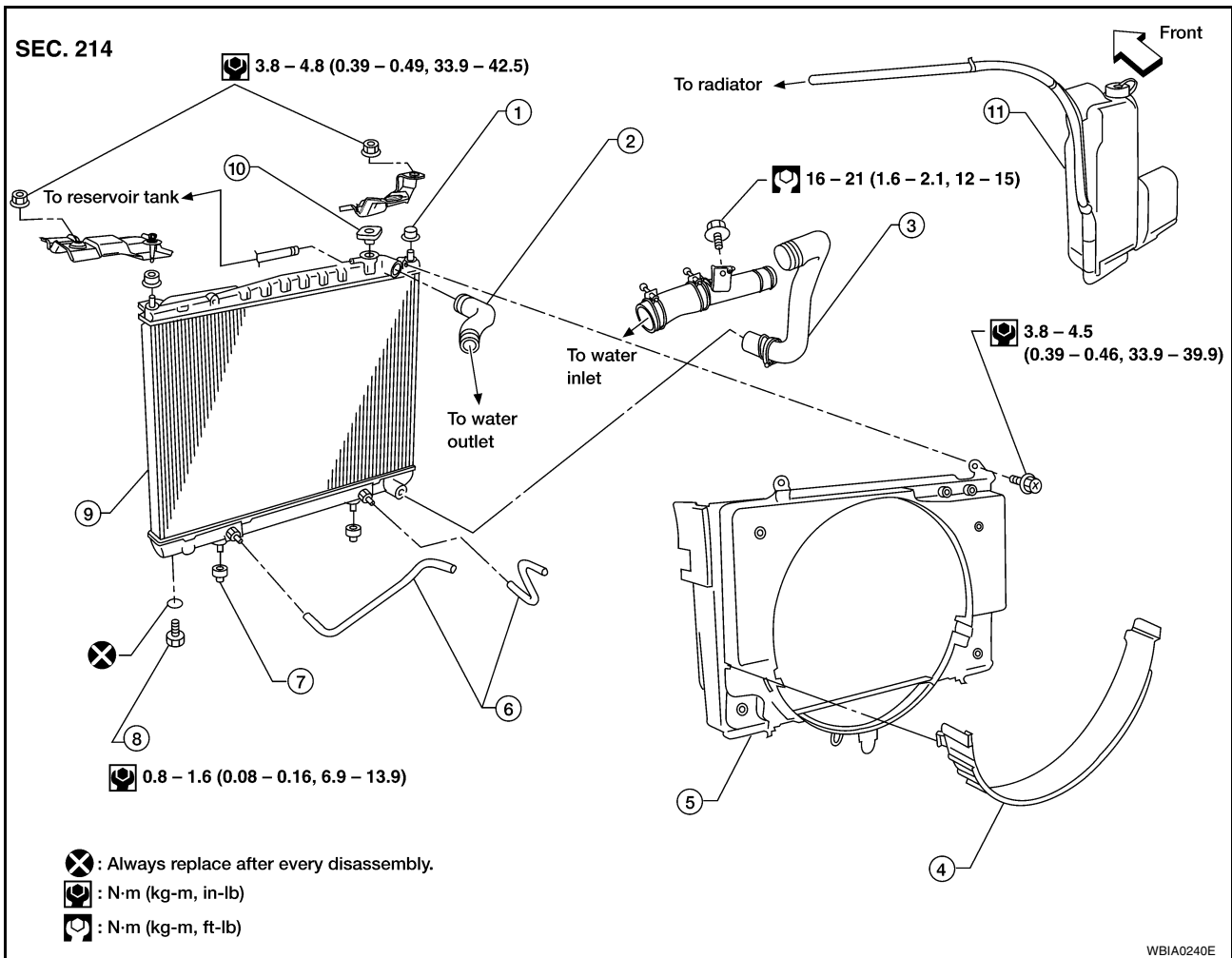

- | | | |
|--------------------------|--------------------------|-------------------------|
| 1. Mounting rubber | 2. Radiator upper hose | 3. Radiator lower hose |
| 4. Radiator lower shroud | 5. Radiator upper shroud | 6. A/T oil cooler hoses |
| 7. Mounting rubber | 8. Radiator drain plug | 9. Radiator |
| 10. Radiator filler cap | 11. Radiator reservoir | |

Removal and Installation

1. Remove undercover.
2. Drain coolant from radiator drain plug. Refer to [MA-26. "DRAINING ENGINE COOLANT"](#).
3. Remove air duct (from mass air flow sensor to throttle body).
4. Disconnect radiator upper and lower hoses.
5. Remove A/T oil cooler hoses, if equipped.
6. Remove radiator lower shroud.
7. Disconnect reservoir tank hose.
8. Remove the radiator.
9. After repairing or replacing the radiator as necessary, installation is in the reverse order of removal.
10. Refill the engine cooling system. Refer to [MA-26. "REFILLING ENGINE COOLANT"](#).
 - After installation, run the engine until it reaches operating temperature and check the system for leaks.

RADIATOR

[VG33E and VG33ER]

EBS00GW3

Inspection

1. Apply pressure with Tool.

Specified test pressure : 157 kPa (1.6 kg/cm² , 23 psi)

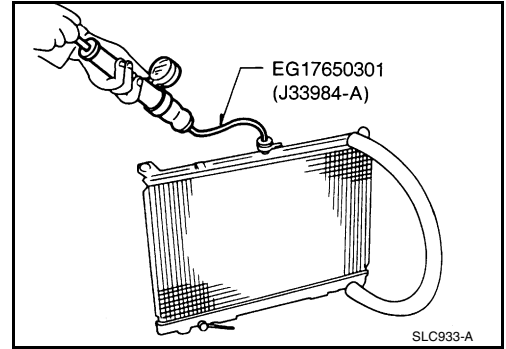

2. Check radiator for leaks in water tank by looking for bubbles.

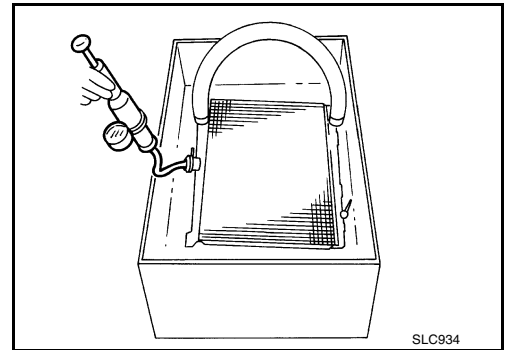

A
CO
C
D
E
F
G
H
I
J
K
L
M

COOLING FAN (CRANKSHAFT DRIVEN)

[VG33E and VG33ER]

COOLING FAN (CRANKSHAFT DRIVEN)

PFP:21060

Removal and Installation

EBS00GW4

- Do not release the drive belt tension by removing the fan/water pump pulley.
- Fan coupling cannot be disassembled and should be replaced as a unit. If front mark **F** is present, install fan so that side marked **F** faces the front.
- Install the drive belt only after the fan and fan coupling to water pump flange bolts/nuts have been properly torqued.
- Proper alignment of these components is essential. Improper alignment will cause them to wobble and may eventually cause the fan to separate from the water pump causing extensive damage.

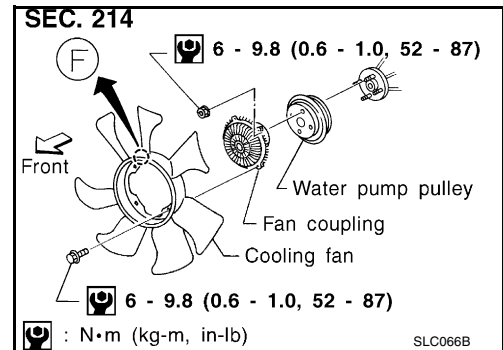

Inspection

EBS00GW5

WARNING:

When the engine is running, keep hands and clothing away from moving parts such as drive belts and fan.

- Check fan coupling for rough operation, wobbling, oil leakage or bent bimetal fins.

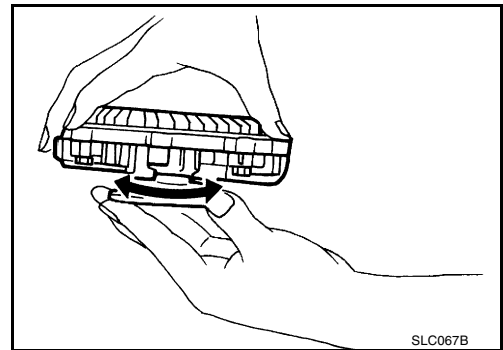

- After assembly, verify the fan does not wobble or flap while the engine is running.

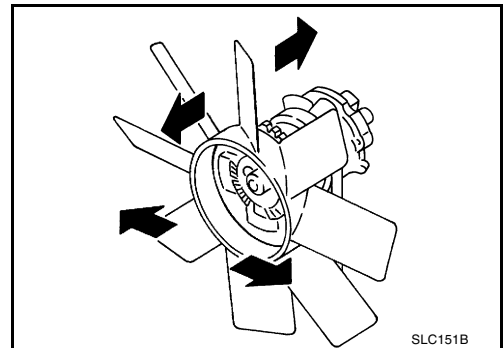

SERVICE DATA AND SPECIFICATIONS (SDS)

[VG33E and VG33ER]

SERVICE DATA AND SPECIFICATIONS (SDS)

PFP:00030

Thermostat

EBS00GW6

Description	VG33E	VG33ER
Valve opening temperature °C (°F)	82 (180)	76.5 (170)
Valve lift mm/°C (in/°F)	More than 10/95 (0.39/203)	More than 8 mm/90°C (0.31 in/194°F)

Radiator

EBS00GW7

Unit: kPa (kg/cm², psi)

Cap relief pressure	Standard	78 - 98 (0.8 - 1.0, 11 - 14)
	Limit	59 (0.6, 9)
Leakage test pressure	157 (1.6, 23)	

A
CO
C
D
E
F
G
H
I
J
K
L
M

SERVICE DATA AND SPECIFICATIONS (SDS)

[VG33E and VG33ER]
