

ENGINE LUBRICATION SYSTEM

CONTENTS

VQ			
PRECAUTIONS	3	SERVICE DATA AND SPECIFICATIONS (SDS)	16
Precautions for Liquid Gasket	3	Standard and Limit	16
LIQUID GASKET APPLICATION PROCEDURE...	3	OIL PRESSURE	16
PREPARATION	4	OIL CAPACITY (APPROXIMATE)	16
Special Service Tools	4	OIL PUMP	16
Commercial Service Tools	4	REGULATOR VALVE	16
LUBRICATION SYSTEM	5		
Lubrication Circuit	5	YD	
System Chart	6	PRECAUTIONS	17
ENGINE OIL	7	Precautions for Liquid Gasket	17
Inspection	7	LIQUID GASKET APPLICATION PROCEDURE..	17
ENGINE OIL LEVEL	7	PREPARATION	18
ENGINE OIL APPEARANCE	7	Special Service Tools	18
ENGINE OIL LEAKAGE	7	Commercial Service Tools	18
ENGINE OIL PRESSURE CHECK	7	LUBRICATION SYSTEM	19
Changing Engine Oil	8	Lubrication Circuit	19
OIL FILTER	10	ENGINE OIL	20
Removal and Installation	10	Inspection	20
REMOVAL	10	ENGINE OIL LEVEL	20
INSTALLATION	10	ENGINE OIL APPEARANCE	20
INSPECTION AFTER INSTALLATION	10	ENGINE OIL LEAKAGE	20
OIL COOLER	11	ENGINE OIL PRESSURE CHECK	20
Components	11	Changing Engine Oil	21
Removal and Installation	11	OIL FILTER	23
REMOVAL	11	Removal and Installation	23
INSPECTION AFTER REMOVAL	12	REMOVAL	23
INSTALLATION	12	INSTALLATION	23
INSPECTION AFTER INSTALLATION	12	INSPECTION AFTER INSTALLATION	23
OIL PUMP	13	OIL FILTER BRACKET	24
Components	13	Components	24
Removal and Installation	13	Removal and Installation	24
REMOVAL	13	REMOVAL	24
INSTALLATION	13	INSTALLATION	25
INSPECTION AFTER INSTALLATION	13	INSPECTION AFTER INSTALLATION	25
Disassembly and Assembly	13		
DISASSEMBLY	13		
INSPECTION AFTER DISASSEMBLY	14		
ASSEMBLY	15		

OIL COOLER	26	Components	29
Components	26	Disassembly and Assembly	29
Removal and Installation	26	DISASSEMBLY	29
REMOVAL	26	INSPECTION AFTER DISASSEMBLY	30
INSPECTION AFTER REMOVAL	27	ASSEMBLY	31
INSTALLATION	27	SERVICE DATA AND SPECIFICATIONS (SDS)	32
INSPECTION AFTER INSTALLATION	27	Standard and Limit	32
OIL PUMP	29	OIL PRESSURE	32
Removal and Installation	29	OIL CAPACITY (APPROXIMATE)	32
REMOVAL	29	OIL PUMP	32
INSTALLATION	29	REGULATOR VALVE	32
INSPECTION AFTER INSTALLATION	29		

PRECAUTIONS

Precautions for Liquid Gasket LIQUID GASKET APPLICATION PROCEDURE

1. Remove the old liquid gasket adhering to the liquid gasket application surface and the mating surface.
 - Remove the liquid gasket completely from the liquid gasket application surface, mounting bolts, and bolt holes.
2. Wipe the liquid gasket application surface and the mating surface with white gasoline (lighting and heating use) to remove adhering moisture, grease and foreign materials.
3. Attach liquid gasket tube to the tube presser [SST].
Use Genuine Liquid Gasket or equivalent.
 - Within five minutes of liquid gasket application, install the mating component.
 - If the liquid gasket protrudes, wipe it off immediately.
 - Do not retighten mounting bolts or nuts after the installation.
 - After 30 minutes or more have passed from the installation, fill engine oil and engine coolant.

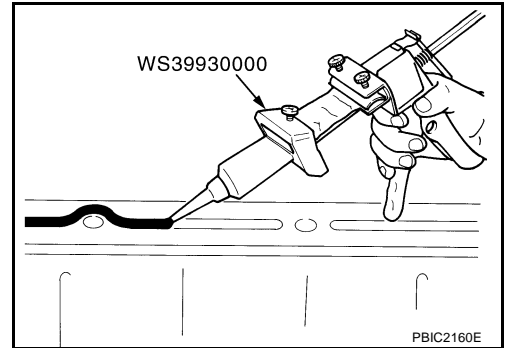

PREPARATION

[VQ]

PFP:00002

PREPARATION

Special Service Tools

GBS000FA

Tool number Tool name	Description
ST25051001 Oil pressure gauge	Measuring oil pressure Maximum measuring range: 2,452 kPa (25 kg/cm² , 356 psi)
ST25052000 Hose	Adapting oil pressure gauge to oil pan (upper)
KV10115801 Oil filter wrench	Removing oil filter a: 64.3 mm (2.531 in)
WS39930000 Tube presser	Pressing the tube of liquid gasket

Commercial Service Tools

GBS000FB

Tool name	Description
Deep socket	Removing and installing oil pressure switch a: 27 mm (1.06 in)

LUBRICATION SYSTEM

PFP:15010

Lubrication Circuit

GBS000FC

A
LU
C
D
E
F
G
H
I
J
K
L
M

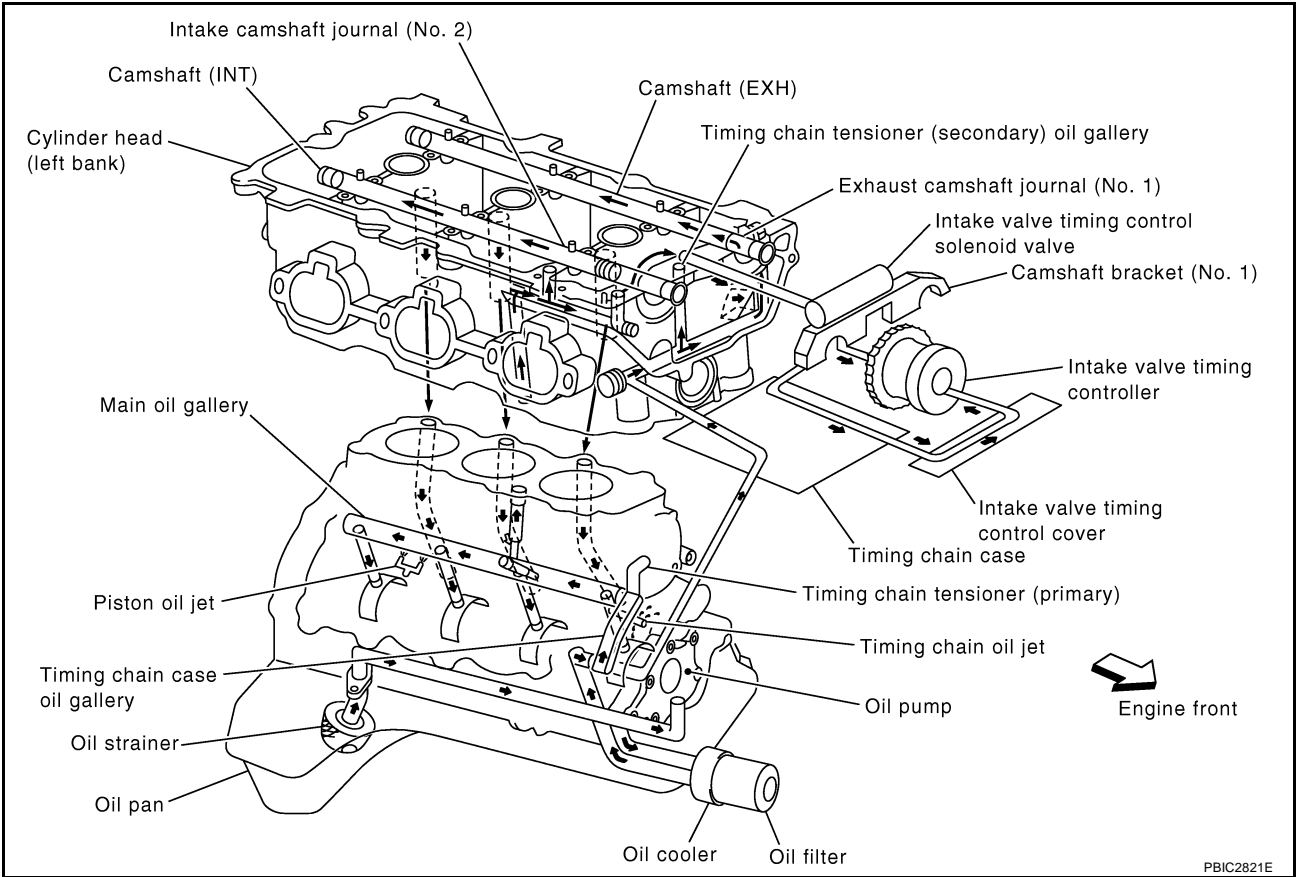

LUBRICATION SYSTEM

[VQ]

System Chart

GBS000FD

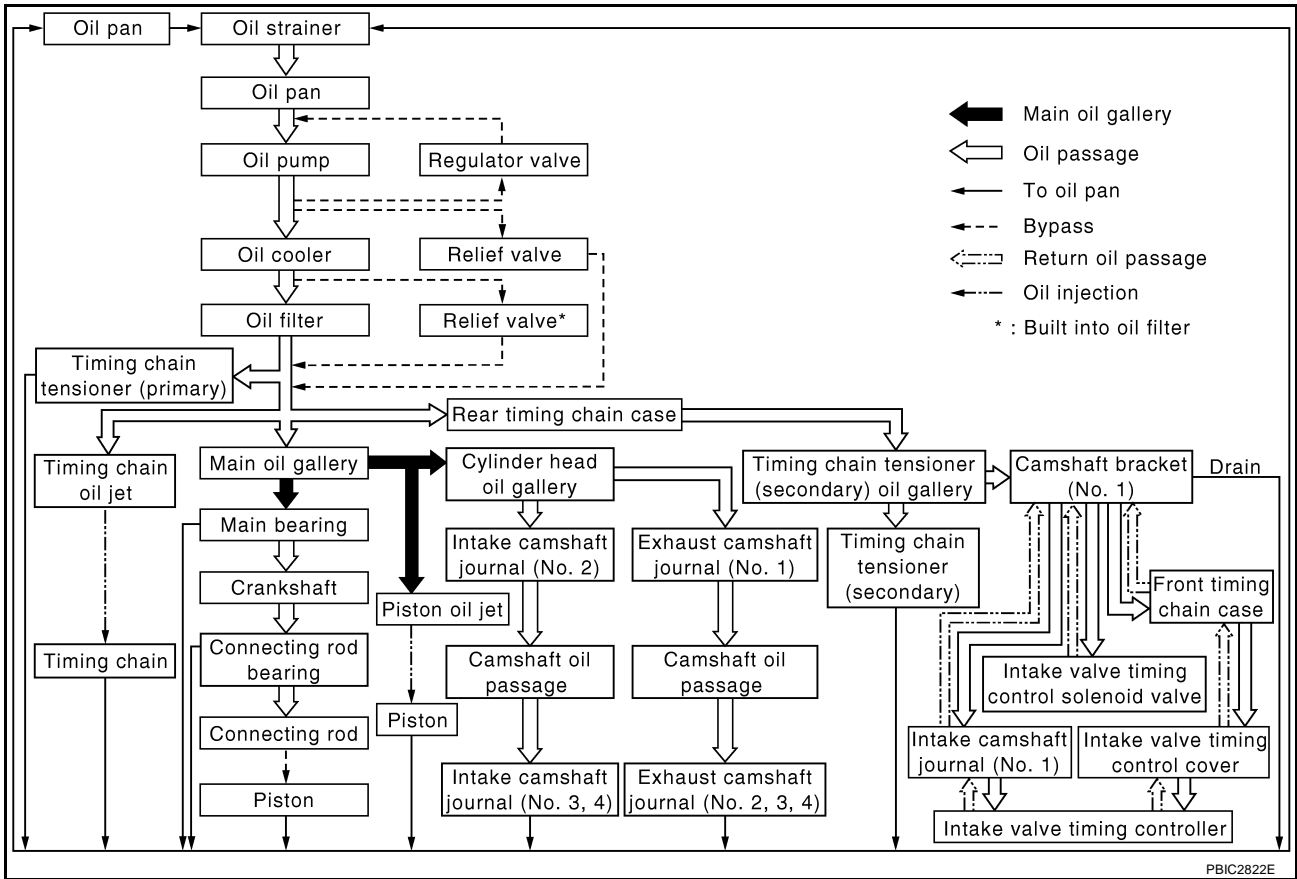

PBIC2822E

ENGINE OIL**Inspection
ENGINE OIL LEVEL****NOTE:**

Before starting engine, put vehicle horizontally and check the engine oil level. If engine is already started, stop it and allow 10 minutes before checking.

1. Pull out oil level gauge and wipe it clean.
2. Insert oil level gauge and make sure the engine oil level is within the range shown in the figure.
3. If it is out of range, adjust it.

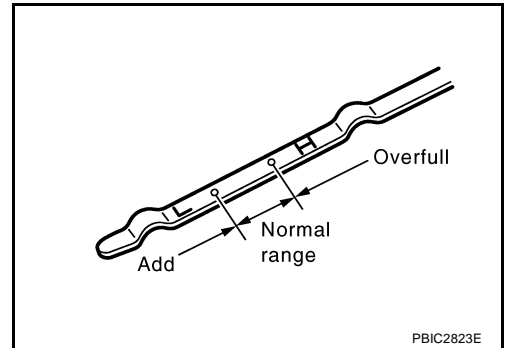
**ENGINE OIL APPEARANCE**

- Check engine oil for white turbidity or heavy contamination.
- If engine oil becomes turbid and white, it is highly probable that it is contaminated with engine coolant. Repair or replace damaged parts.

ENGINE OIL LEAKAGE

Check for oil leakage around the following areas:

- Oil pans (lower and upper)
- Oil pan drain plug
- Oil pressure switch
- Oil filter
- Oil cooler
- Water pump cover
- Chain tensioner cover
- Intake valve timing control cover and intake valve timing control solenoid valve
- Mating surface between cylinder block and cylinder head
- Mating surface between lower cylinder block and cylinder block
- Mating surface between cylinder head and rocker cover
- Mating surface between front timing chain case and rear timing chain case
- Mating surface between rear timing chain case and cylinder head
- Mating surface between rear timing chain case and cylinder block
- Mating surface between rear timing chain case and lower cylinder block
- Mating surface between rear timing chain case and oil pan (upper)
- Crankshaft oil seals (front and rear)
- Oil level gauge guide
- Camshaft position sensor (PHASE)

ENGINE OIL PRESSURE CHECK**WARNING:**

- **Be careful not to burn yourself, as the engine oil may be hot.**
 - **Oil pressure check should be done in "Neutral position" (M/T models) or "Parking position" (A/T models).**
1. Check the engine oil level. Refer to [LU-7, "ENGINE OIL LEVEL"](#).
 2. Remove engine undercover front and engine undercover middle. Refer to [EI-15, "FRONT BUMPER"](#).

ENGINE OIL

[VQ]

3. Disconnect harness connector at oil pressure switch (2), and remove oil pressure switch (2) using deep socket (commercial service tool).

1 : Oil pan (upper)

↔ : Engine front

CAUTION:

Do not drop or shock oil pressure switch.

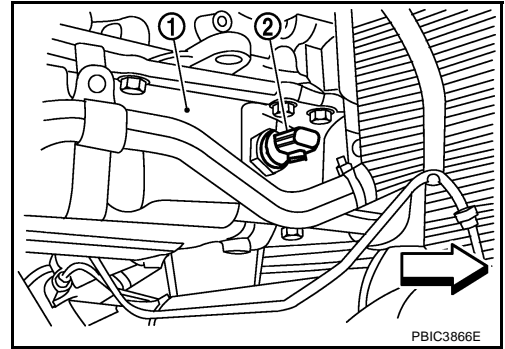

4. Install the oil pressure gauge and hose [SST].

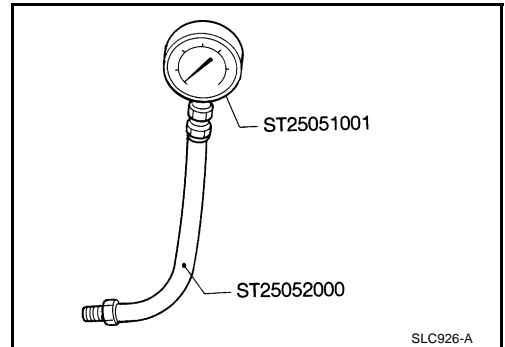

5. Start engine and warm it up to normal operating temperature.
6. Check oil pressure with engine running under no-load.

NOTE:

When engine oil temperature is low, engine oil pressure becomes high.

Engine oil pressure [Engine oil temperature at 80°C (176°F)]

Engine speed rpm	Approximate discharge pressure kPa (bar, kg/cm ² , psi)
Idle speed	More than 98 (0.98, 1.0, 14)
2,000	More than 294 (2.94, 3.0, 43)

If difference is extreme, check oil passage and oil pump for oil leaks.

7. After the inspections, install oil pressure switch as follows:
 - a. Remove old liquid gasket adhering to oil pressure switch and engine.
 - b. Apply liquid gasket and tighten oil pressure switch to the specification.
Use Genuine Liquid Gasket or equivalent.

Oil pressure switch:

: 14.7 N·m (1.5 kg-m, 11 ft-lb)

- c. After warming up engine, make sure there is no leakage of engine oil with running engine.

Changing Engine Oil

GBS000FF

WARNING:

- Be careful not to burn yourself, as the engine oil may be hot.
 - Prolonged and repeated contact with used engine oil may cause skin cancer; try to avoid direct skin contact with used engine oil. If skin contact is made, wash thoroughly with soap or hand cleaner as soon as possible.
1. Warm up engine, put vehicle horizontally and check for engine oil leakage from engine components. Refer to [LU-7, "ENGINE OIL LEAKAGE"](#).
 2. Stop engine and wait for 10 minutes.
 3. Loosen oil filler cap and then remove drain plug.
 4. Drain engine oil.

5. Install drain plug with new washer. Refer to [EM-28, "OIL PAN AND OIL STRAINER"](#) .

CAUTION:

Be sure to clean drain plug and install with new washer.

Oil pan drain plug:

: **34.3 N-m (3.5 kg-m, 25 ft-lb)**

6. Refill with new engine oil.

Engine oil specification and viscosity:

Refer to [MA-13, "RECOMMENDED FLUIDS AND LUBRICANTS"](#) .

Engine oil capacity (Approximate):

Unit: ℓ (Imp qt)

Drain and refill	With oil filter change	5.1 (4-1/2)
	Without oil filter change	4.8 (4-1/4)
Dry engine (Overhaul)		6.3 (5-1/2)

CAUTION:

- **When filling engine oil, do not pull out oil level gauge.**
 - **The refill capacity depends on the engine oil temperature and drain time. Use these specifications for reference only.**
 - **Always use the oil level gauge to determine when the proper amount of engine oil is in the engine.**
7. Warm up engine and check area around drain plug and oil filter for oil leakage.
8. Stop engine and wait for 10 minutes.
9. Check the engine oil level. Refer to [LU-7, "ENGINE OIL LEVEL"](#) .

OIL FILTER

Removal and Installation

REMOVAL

1. Remove engine undercover front and engine undercover middle. Refer to [EI-15, "FRONT BUMPER"](#) .
2. Using the oil filter wrench [SST: KV10115821] (A), remove oil filter (1).

2 : Oil cooler

← : Vehicle front

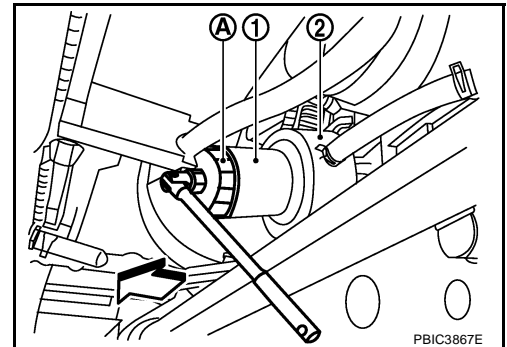

CAUTION:

- Be careful not to get burned when engine and engine oil are hot.
- When removing, prepare a shop cloth to absorb any engine oil leakage or spillage.
- Do not allow engine oil to adhere to drive belts.
- Completely wipe off any engine oil that adheres to engine and vehicle.
- Use Genuine Nissan Oil Filter or equivalent.

INSTALLATION

1. Remove foreign materials adhering to oil filter installation surface.
2. Apply new engine oil to the oil seal contact surface of new oil filter.

Use Genuine Nissan Oil Filter or equivalent.

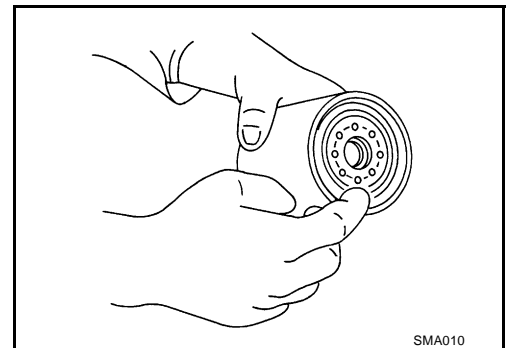

3. Screw oil filter manually until it touches the installation surface, then tighten it by 2/3 turn. Or tighten to specification.

Oil filter:

: 18 N·m (1.8 kg·m, 13 ft·lb)

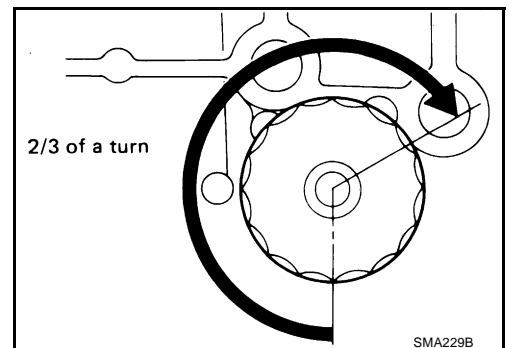

INSPECTION AFTER INSTALLATION

1. Check the engine oil level. Refer to [LU-7, "ENGINE OIL"](#) .
2. Start engine, and check there is no leaks of engine oil.
3. Stop engine and wait for 10 minutes.
4. Check the engine oil level and add engine oil. Refer to [LU-7, "ENGINE OIL"](#) .

OIL COOLER

PFP:21305

Components

GBS000FH

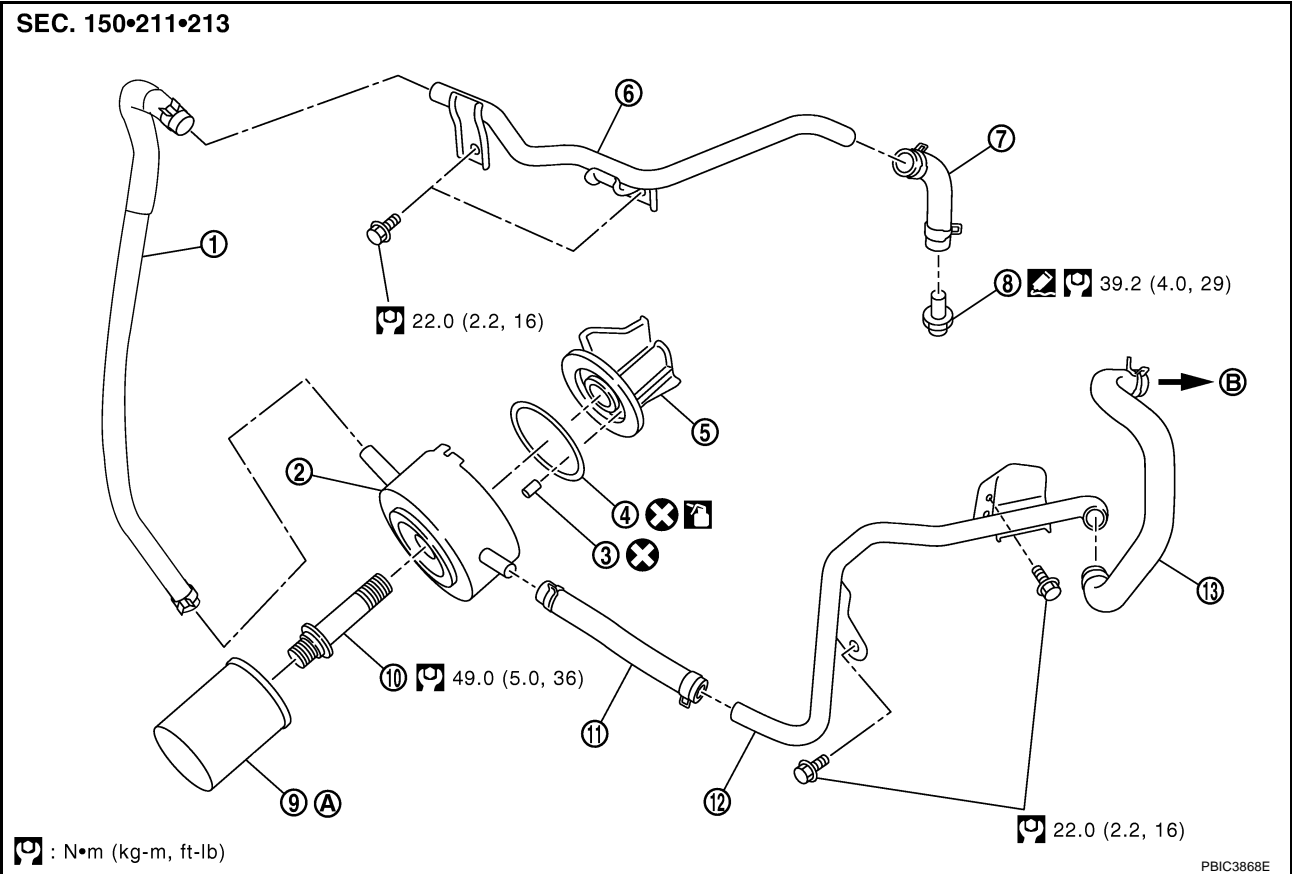

- | | | |
|--------------------|-------------------------------|-----------------|
| 1. Water hose | 2. Oil cooler | 3. Relief valve |
| 4. O-ring | 5. Oil pan (upper) front side | 6. Water pipe |
| 7. Water hose | 8. Water connector | 9. Oil filter |
| 10. Connector bolt | 11. Water hose | 12. Water pipe |
| 13. Water hose | | |
- A. Refer to "OIL FILTER" in LU section. B. To water inlet and thermostat assembly

- Refer to [GI-10, "Components"](#) for symbol marks in the figure.

Removal and Installation

GBS000FI

CAUTION:

- Be careful not to get burned when engine oil and engine coolant are hot.
- When removing, prepare a shop cloth to absorb any engine oil and engine coolant leakage or spillage.
- Completely wipe off any engine oil and engine coolant that adhere to engine and vehicle.
- Do not allow engine oil and engine coolant to adhere to drive belt.

REMOVAL

NOTE:

When removing oil cooler only, step 2 is unnecessary.

- Remove engine undercover front and engine undercover middle. Refer to [EI-15, "FRONT BUMPER"](#).
- Drain engine coolant from radiator and cylinder block. Refer to [CO-10, "Changing Engine Coolant"](#) and [EM-107, "CYLINDER BLOCK"](#).

NOTE:

Perform this step when removing water hoses and water pipes.

- Remove oil filter. Refer to [LU-10, "OIL FILTER"](#).

CAUTION:

Do not spill engine oil on drive belts.

4. Disconnect water hoses from oil cooler.

- When removing oil cooler only, pinching water hoses near oil cooler to prevent engine coolant spilling.

CAUTION:

- **Perform this step when engine is cold.**
- **Do not spill engine coolant on drive belts.**

5. Loosen connector bolt, and remove oil cooler.

CAUTION:

Do not spill engine oil and engine coolant to rubber parts such as drive belts and engine mounting insulator.

6. Remove water pipes, as necessary.

INSPECTION AFTER REMOVAL

Oil Cooler

Check oil cooler for cracks. Check oil cooler for clogging by blowing through engine coolant inlet. If necessary, replace oil cooler.

Relief Valve

Check relief valve for movement, cracks and breaks by pushing the ball. If replacement is necessary, remove relief valve by prying it out with suitable tool. Install a new relief valve in place by tapping it.

INSTALLATION

Note the following, and install in the reverse order of removal.

- Make sure that no foreign objects are adhering to the installation planes of oil cooler and oil pan (upper).
- Align cutout on oil cooler with protrusion on oil pan (upper) side, and tighten connector bolt.

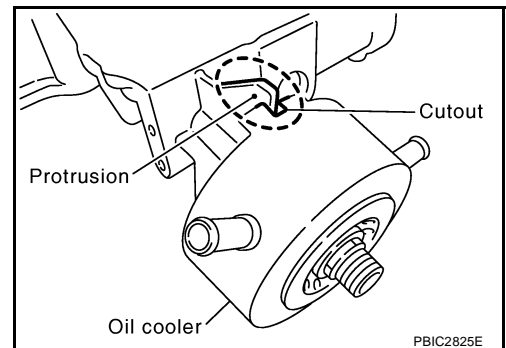

INSPECTION AFTER INSTALLATION

1. Check the engine oil level and the engine coolant level, and add engine oil and engine coolant. Refer to [LU-7, "ENGINE OIL"](#) and [CO-10, "ENGINE COOLANT"](#).
2. Start engine, and make sure that there is no leaks of engine oil or engine coolant.
3. Stop engine and wait for 10 minutes.
4. Check the engine oil level and the engine coolant level again. Refer to [LU-7, "ENGINE OIL"](#) and [CO-10, "ENGINE COOLANT"](#).

OIL PUMP

PFP:15010

Components

GBS000FJ

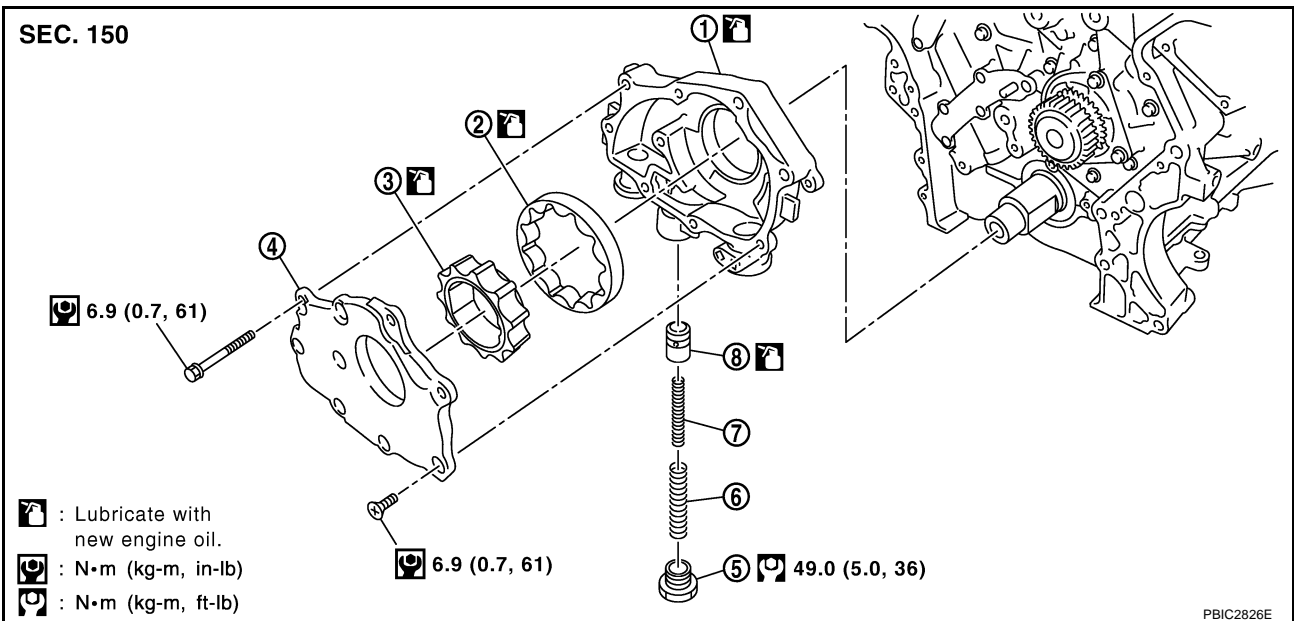

- | | | |
|---------------------------|-------------------------|---------------------------|
| 1. Oil pump body | 2. Oil pump outer rotor | 3. Oil pump inner rotor |
| 4. Oil pump cover | 5. Regulator valve plug | 6. Regulator valve spring |
| 7. Regulator valve spring | 8. Regulator valve | |

Removal and Installation

REMOVAL

GBS000FK

1. Remove oil pans (lower and upper). Refer to [EM-28, "OIL PAN AND OIL STRAINER"](#) .
2. Remove front timing chain case and timing chain (primary). Refer to [EM-53, "TIMING CHAIN"](#) .
3. Remove oil pump assembly.

INSTALLATION

Note the following, and install in the reverse order of removal.

- When installing, align crankshaft flat faces with inner rotor flat faces.

INSPECTION AFTER INSTALLATION

1. Check the engine oil level. Refer to [LU-7, "ENGINE OIL"](#) .
2. Start engine, and check there is no leaks of engine oil.
3. Stop engine and wait for 10 minutes.
4. Check the engine oil level and add engine oil. Refer to [LU-7, "ENGINE OIL"](#) .

Disassembly and Assembly

DISASSEMBLY

GBS000FL

1. Remove oil pump cover.
2. Remove oil pump inner rotor and oil pump outer rotor from oil pump body.
3. After removing regulator valve plug, remove regulator valve springs and regulator valve.

INSPECTION AFTER DISASSEMBLY

Oil Pump Clearance

- Measure the clearance with feeler gauge.
 - Clearance between oil pump outer rotor and oil pump body (position "1")

Standard : 0.120 - 0.195 mm (0.0047 - 0.0077 in)
 - Tip clearance between oil pump inner rotor and oil pump outer rotor (position "2")

Standard : 0.06 - 0.16 mm (0.0024 - 0.0063 in)

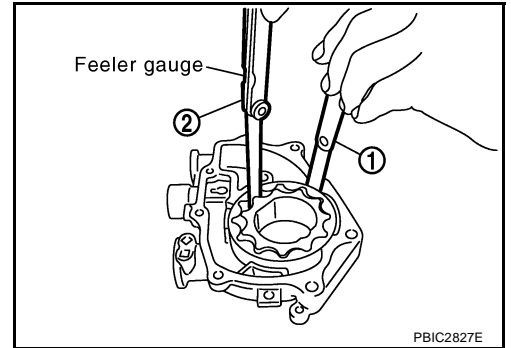

- Measure the clearance with the feeler gauge and straightedge.
 - Side clearance between oil pump inner rotor and oil pump body (position "3")

Standard : 0.030 - 0.070 mm (0.0012 - 0.0028 in)
 - Side clearance between oil pump outer rotor and oil pump body (position "4")

Standard : 0.05 - 0.09 mm (0.0020 - 0.0035 in)

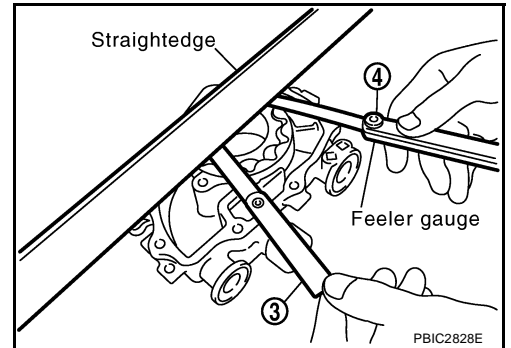

- Calculate the clearance between oil pump inner rotor and oil pump body as follows:

OIL PUMP BODY INNER DIAMETER

- Measure the inner diameter of oil pump body with inside micrometer. (Position "5")

OIL PUMP INNER ROTOR OUTER DIAMETER

- Measure the outer diameter of protruded portion of oil pump inner rotor with micrometer. (Position "6")

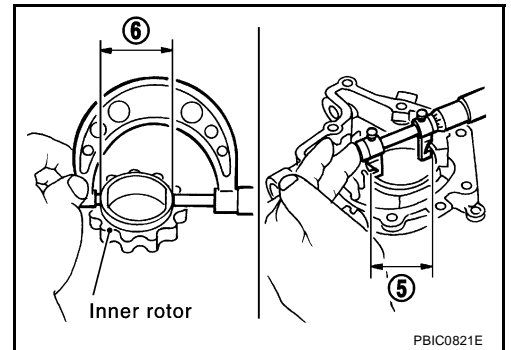

OIL PUMP INNER ROTOR TO OIL PUMP BODY CLEARANCE

- (Clearance) = (Oil pump body inner diameter) – (Oil pump inner rotor outer diameter)

Standard : 0.045 - 0.091 mm (0.0018 - 0.0036 in)

- If measured/calculated values are out of the standard, replace oil pump assembly.

Regulator Valve Clearance

(Clearance) = (Valve hole diameter) – (Regulator valve outer diameter)

Standard : 0.025 - 0.070 mm (0.0010 - 0.0028 in)

- If the calculated value is out of the standard, replace oil pump assembly.

CAUTION:

- Coat regulator valve with engine oil.
- Make sure that it falls smoothly into valve hole by its own weight.

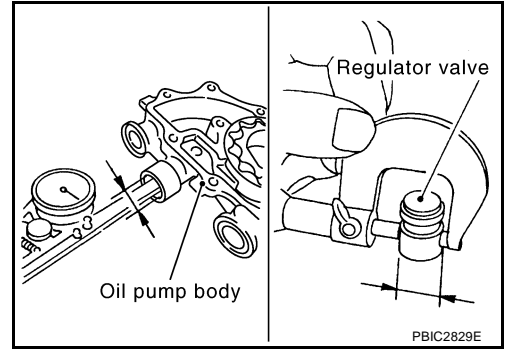

ASSEMBLY

Note the following, and assemble in the reverse order of disassembly.

- Install oil pump inner rotor with the groove faced and oil pump outer rotor with the punch mark to oil pump cover side.

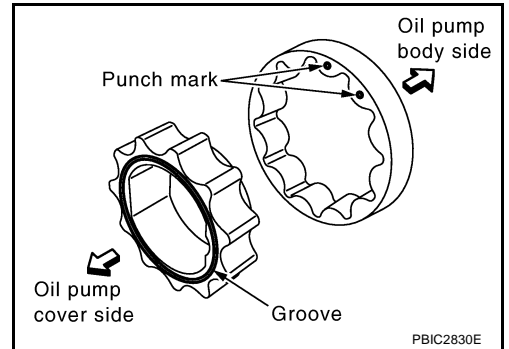

A
LU
 C
 D
 E
 F
 G
 H
 I
 J
 K
 L
 M

SERVICE DATA AND SPECIFICATIONS (SDS)

[VQ]

SERVICE DATA AND SPECIFICATIONS (SDS)

PFP:00030

Standard and Limit OIL PRESSURE

GBS000FM

Engine speed rpm	Approximate discharge pressure* kPa (bar, kg/cm ² , psi)
Idle speed	More than 98 (0.98, 1.0, 14)
2,000	More than 294 (2.94, 3.0, 43)

*: Engine oil temperature at 80°C (176°F)

OIL CAPACITY (APPROXIMATE)

Unit: ℓ (Imp qt)

Drain and refill	With oil filter change	5.1 (4-1/2)
	Without oil filter change	4.8 (4-1/4)
Dry engine (Overhaul)		6.3 (5-1/2)

OIL PUMP

Unit: mm (in)

Oil pump body to oil pump outer rotor radial clearance	0.120 - 0.195 (0.0047 - 0.0077)
Oil pump inner rotor to oil pump outer rotor tip clearance	0.06 - 0.16 (0.0024 - 0.0063)
Oil pump body to oil pump inner rotor side clearance	0.030 - 0.070 (0.0012 - 0.0028)
Oil pump body to oil pump outer rotor side clearance	0.05 - 0.09 (0.0020 - 0.0035)
Oil pump inner rotor to brazed portion of housing clearance	0.045 - 0.091 (0.0018 - 0.0036)

REGULATOR VALVE

Unit: mm (in)

Regulator valve to oil pump body clearance	0.025 - 0.070 (0.0010 - 0.0028)
--	---------------------------------

PRECAUTIONS

PFP:00001

Precautions for Liquid Gasket LIQUID GASKET APPLICATION PROCEDURE

GBS0001P

1. Remove the old liquid gasket adhering to the liquid gasket application surface and the mating surface.
 - Remove the liquid gasket completely from the liquid gasket application surface, mounting bolts, and bolt holes.
2. Wipe the liquid gasket application surface and the mating surface with white gasoline (lighting and heating use) to remove adhering moisture, grease and foreign materials.
3. Attach liquid gasket tube to the tube presser [SST].
Use Genuine Liquid Gasket or equivalent.
 - Within five minutes of liquid gasket application, install the mating component.
 - If the liquid gasket protrudes, wipe it off immediately.
 - Do not retighten mounting bolts and nuts after the installation.
 - After 30 minutes or more have passed from the installation, fill engine oil and engine coolant.

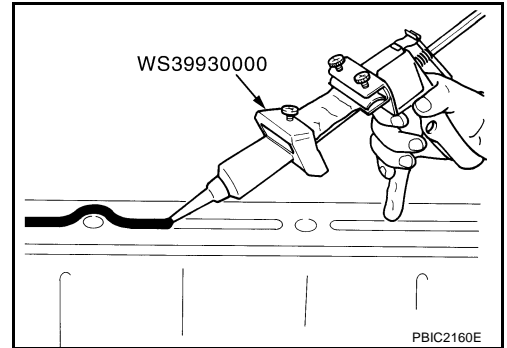

PREPARATION

[YD]

PREPARATION

PFP:00002

Special Service Tools

GBS0001Q

Tool number Tool name	Description
ST25051001 Oil pressure gauge	Measuring oil pressure Maximum measuring range: 2,452 kPa (25 kg/cm² , 356 psi)
ST25052000 Hose	Adapting oil pressure gauge to cylinder block
WS39930000 Tube presser	Pressing the tube of liquid gasket

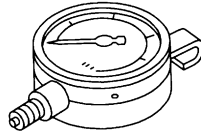

S-NT050

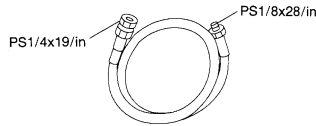

S-NT559

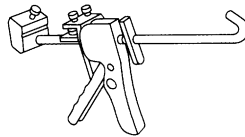

S-NT052

Commercial Service Tools

GBS0001R

Tool name	Description
Deep socket	Removing and installing oil pressure switch a: 24 mm (0.94 in)

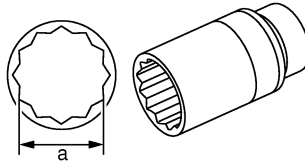

PBIC2072E

LUBRICATION SYSTEM

[YD]

LUBRICATION SYSTEM

PFP:15010

Lubrication Circuit

GBS0001S

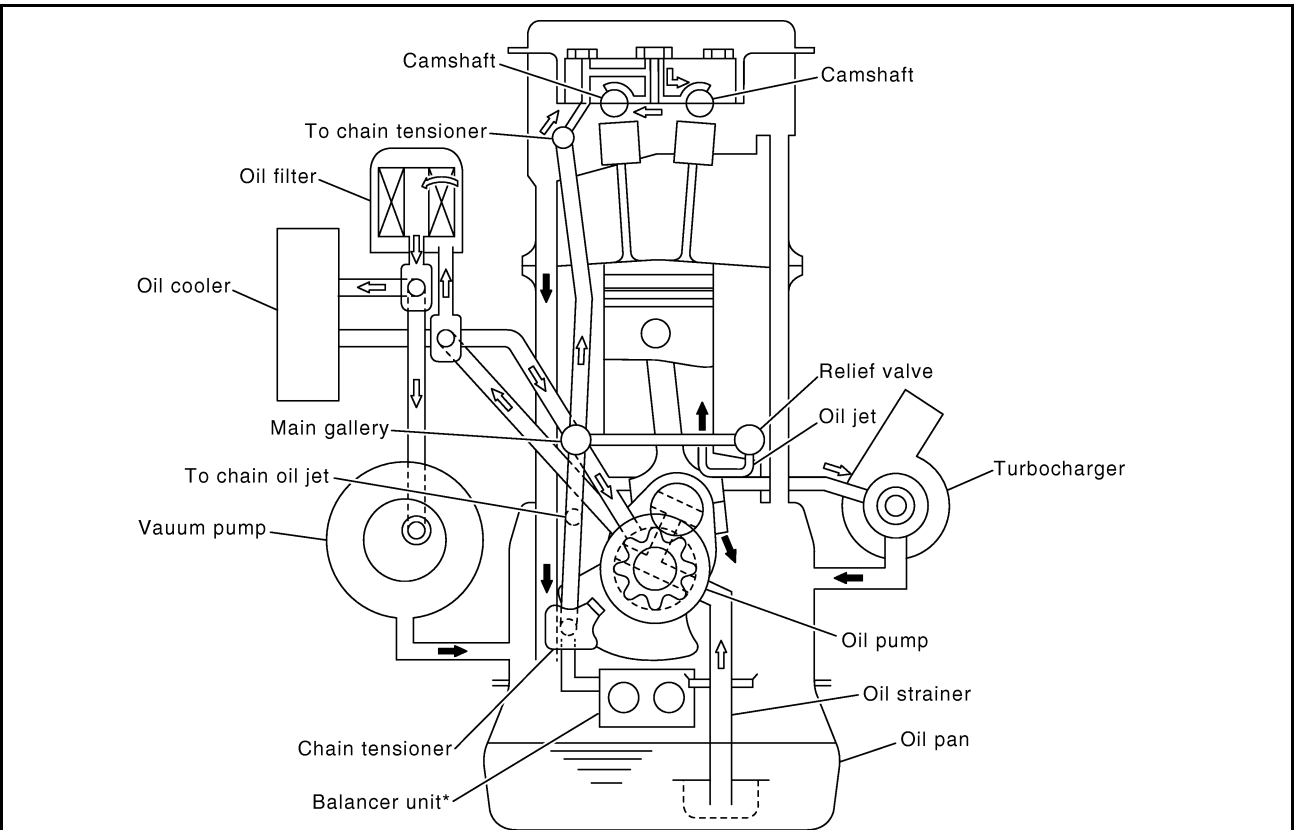

*: 4WD models

- Oil gallery
- By-pass passage
- ← To oil pan
- Oil injection

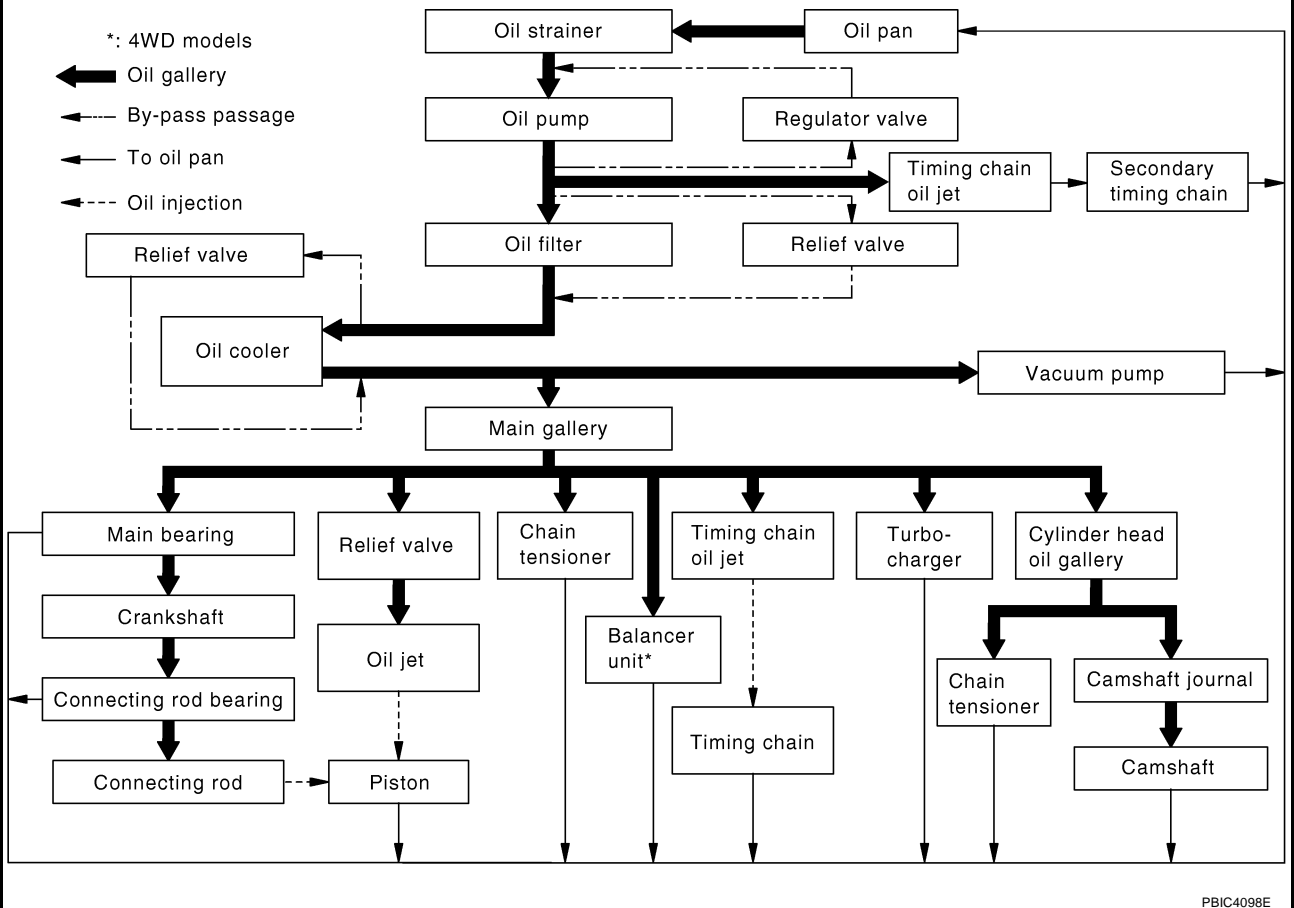

PBIC4098E

ENGINE OIL

PFP:KLA92

Inspection ENGINE OIL LEVEL

GBS0001T

NOTE:

Before starting engine, put vehicle horizontally and check the engine oil level. If engine is already started, stop it and allow 10 minutes before checking.

1. Pull out oil level gauge and wipe it clean.
2. Insert oil level gauge and make sure the engine oil level is within the range shown in the figure.
3. If it is out of range, adjust it.

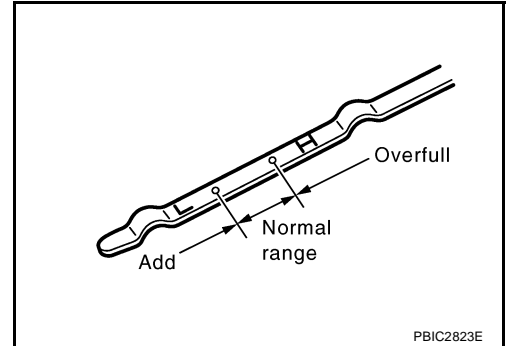

ENGINE OIL APPEARANCE

- Check engine oil for white turbidity or heavy contamination.
- If engine oil becomes turbid and white, it is highly probable that it is contaminated with engine coolant. Repair or replace damaged parts.

ENGINE OIL LEAKAGE

Check for engine oil leakage around the following area.

- Oil pan (lower and upper)
- Oil pan drain plug
- Oil pressure switch
- Oil filter and oil filter bracket
- Oil cooler
- Oil pump housing
- Vacuum pump
- Cylinder head rear cover assembly
- Front and rear chain cases
- Mating surface between cylinder block and cylinder head
- Mating surface between cylinder head and rocker cover
- Front and rear oil seals
- Turbocharger
- Oil tube connecting parts from turbocharger

ENGINE OIL PRESSURE CHECK

WARNING:

- Be careful not to burn yourself, as the engine oil may be hot.
 - Oil pressure check should be done in "Neutral position"(M/T models) or "Parking position"(A/T models).
1. Check the engine oil level. Refer to [LU-20, "ENGINE OIL LEVEL"](#) .
 2. Remove engine undercover front and engine undercover middle. Refer to [EI-15, "FRONT BUMPER"](#) .

ENGINE OIL

[YD]

3. Disconnect harness connector at oil pressure switch (1), and remove oil pressure switch (1) using deep socket (commercial service tool).

- 2 : Oil cooler
- ⇐ : Engine front

CAUTION:
Do not drop or shock oil pressure switch.

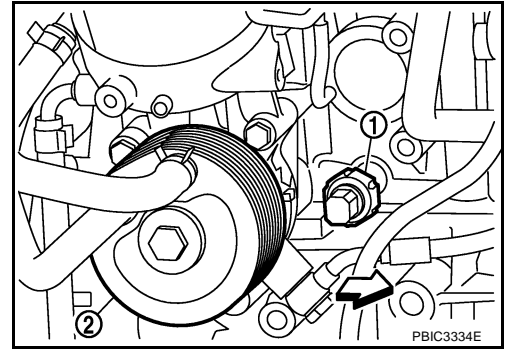

4. Install the oil pressure gauge and hose [SST].

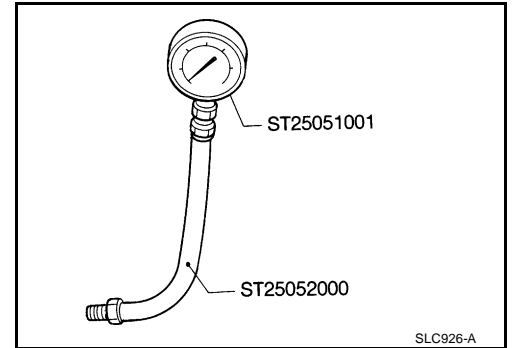

5. Start engine and warm it up to normal operating temperature.
6. Check oil pressure with engine running under no-load.

NOTE:
When engine oil temperature is low, engine oil pressure becomes high.

Engine oil pressure [Engine oil temperature at 80°C (176°F)]

Engine speed rpm	Approximate discharge pressure kPa (bar, kg/cm ² , psi)
Idle speed	More than 120 (1.20, 1.22, 17.4)
2,000	More than 250 (2.50, 2.55, 36.3)

If difference is extreme, check oil passage and oil pump for oil leaks.

7. After the inspections, install oil pressure switch as follows.
 - a. Remove old liquid gasket adhering to oil pressure switch and engine.
 - b. Apply liquid gasket and tighten oil pressure switch to the specification.
Use Genuine Liquid Gasket or equivalent.

Oil pressure switch:

: 14.7 N·m (1.5 kg·m, 11 ft·lb)

- c. After warming up engine, make sure that there is no leakage of engine oil with running engine.

Changing Engine Oil

GBS0001U

WARNING:

- Be careful not to burn yourself, as the engine oil may be hot.
 - Prolonged and repeated contact with used engine oil may cause skin cancer; try to avoid direct skin contact with used engine oil. If skin contact is made, wash thoroughly with soap or hand cleaner as soon as possible.
1. Warm up engine, put vehicle horizontally and check for engine oil leakage from engine components. Refer to [LU-20, "ENGINE OIL LEAKAGE"](#).
 2. Stop engine and wait for 10 minutes.

ENGINE OIL

[YD]

3. Loosen oil filler cap (1) and then remove drain plug (3).

2 : Oil filter

↶ : Engine front

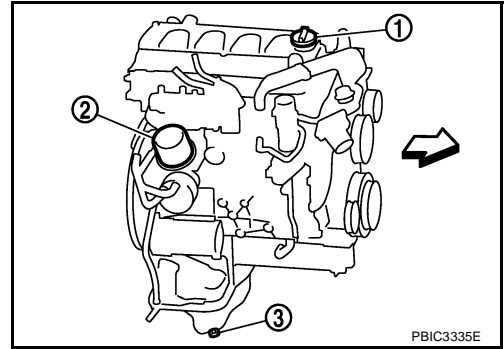

4. Drain engine oil.

5. Install drain plug with new washer. Refer to [EM-180, "OIL PAN AND OIL STRAINER"](#) .

CAUTION:

Be sure to clean drain plug and install with new washer.

Oil pan drain plug:

: 34.3 N·m (3.5 kg·m, 25 ft·lb)

6. Refill with new engine oil.

Engine oil specification and viscosity:

Refer to [MA-13, "RECOMMENDED FLUIDS AND LUBRICANTS"](#) .

Engine oil capacity (Approximate):

Unit: ℓ (Imp qt)

Drain and refill	With oil filter change	7.6 (6-5/8)
	Without oil filter change	7.1 (6-1/4)
Dry engine (Overhaul)		7.9 (7)

CAUTION:

- When filling engine oil, do not pull out oil level gauge.
 - The refill capacity depends on the engine oil temperature and drain time. Use these specifications for reference only.
 - Always use the oil level gauge to determine when the proper amount of engine oil is in the engine.
7. Warm up engine and check area around drain plug and oil filter for oil leakage.
8. Stop engine and wait for 10 minutes.
9. Check the engine oil level. Refer to [LU-20, "ENGINE OIL LEVEL"](#) .

OIL FILTER

Removal and Installation

REMOVAL

1. Remove engine undercover middle.
2. Place a pan to catch the engine oil under the lower part of drain hose outlet before removing oil filter.
3. Using the oil filter wrench, remove oil filter.

CAUTION:

- Be careful not to get burned when engine and engine oil are hot.
- When removing, prepare a shop cloth to absorb any engine oil leakage or spillage.
- Do not allow engine oil to adhere to drive belts.
- Completely wipe off any engine oil that adhere to engine and vehicle.
- Oil filter is provided with a relief valve. Use Genuine Nissan Oil Filter or equivalent.

INSTALLATION

1. Remove foreign materials adhering to the oil filter installation surface.
2. Apply new engine oil to the oil seal contact surface of new oil filter.

Use Genuine Nissan Oil Filter or equivalent.

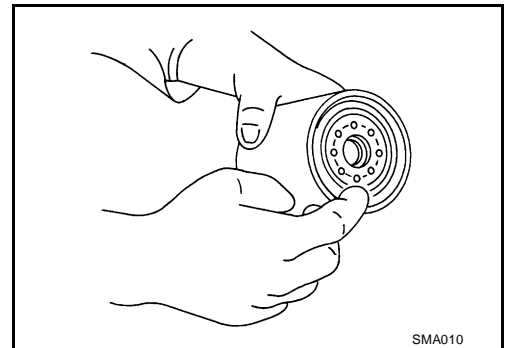

3. Screw oil filter manually until it touches the installation surface, then tighten it by 2/3 turn. Or tighten to specification.

Oil filter:

 **18 N·m (1.8 Kg-m, 13 ft-lb)**

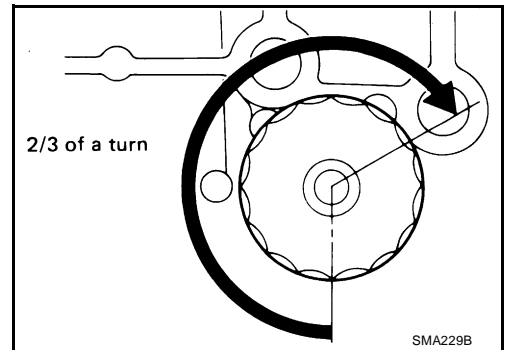

INSPECTION AFTER INSTALLATION

1. Check the engine oil level. Refer to [LU-20, "ENGINE OIL"](#).
2. Start engine, and check there is no leakage of engine oil.
3. Stop engine and wait for 10 minutes.
4. Check the engine oil level and add engine oil. Refer to [LU-20, "ENGINE OIL"](#).

OIL FILTER BRACKET

PFP:15238

Components

GBS0001W

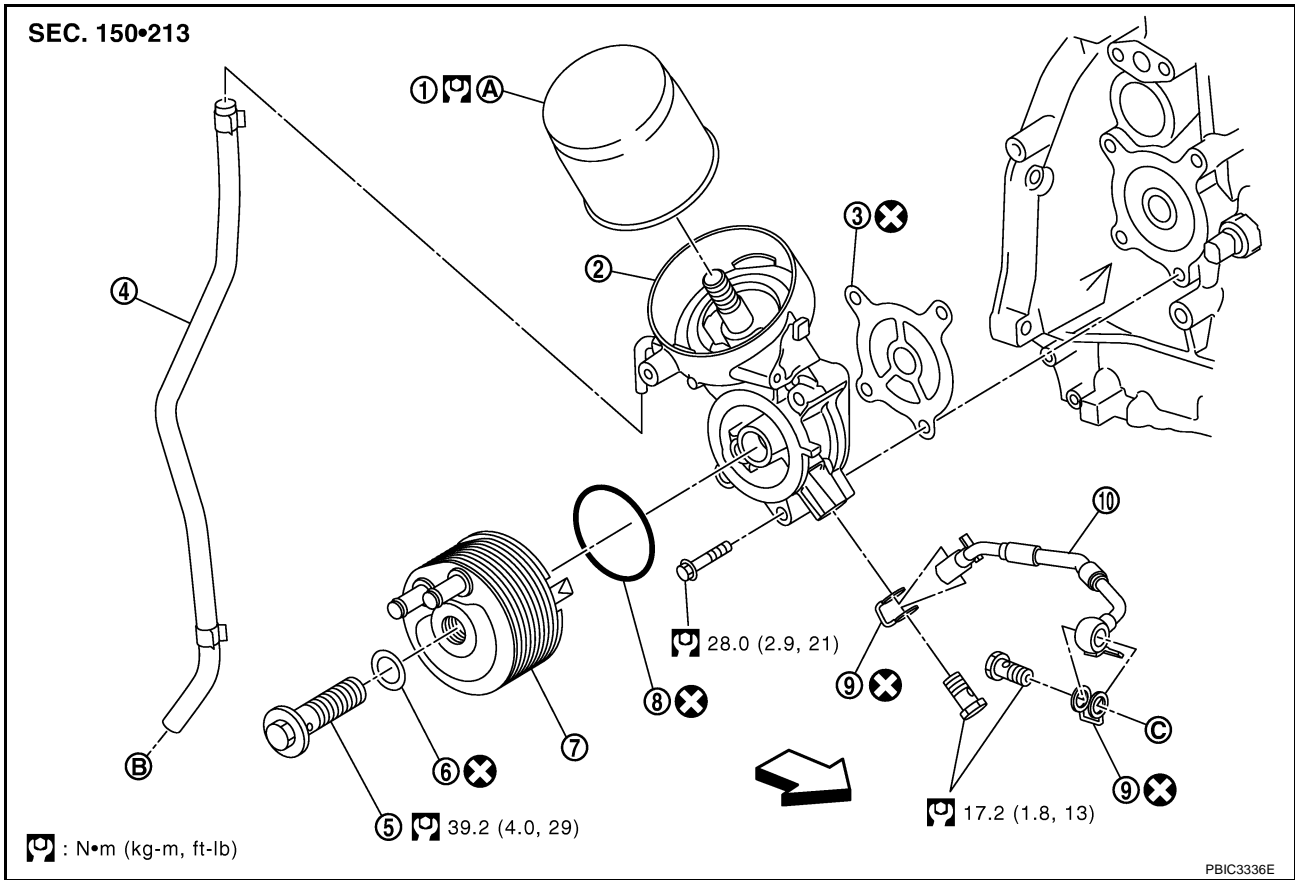

- | | | |
|-------------------------------------|-----------------------|-------------------|
| 1. Oil filter | 2. Oil filter bracket | 3. Gasket |
| 4. Drain hose | 5. Connecting bolt | 6. Washer |
| 7. Oil cooler | 8. O-ring | 9. Cooper washer |
| 10. Oil tube | | |
| A. Refer to LU-23 . | B. To oil pan | C. To vacuum pump |
- ↶ Vehicle front

- Refer to [GI-10, "Components"](#) for symbol marks except in the above.

Removal and Installation

REMOVAL

GBS0001X

- Remove mounting nuts (2) of fuel filter (1), and move it aside with its hoses connected. Temporarily secure it with a rope to avoid putting load on its hose.

↶ : Vehicle front

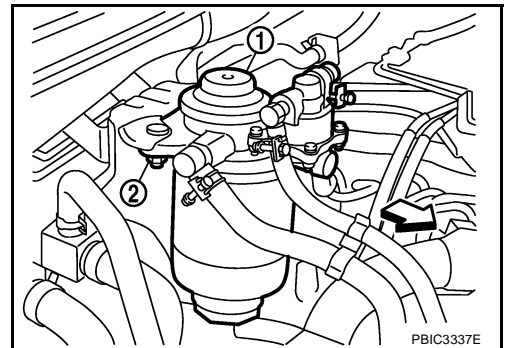

- Remove oil filter. Refer to [LU-23, "OIL FILTER"](#).
- Remove oil cooler. Refer to [LU-26, "OIL COOLER"](#).
- Remove oil filter bracket.

INSTALLATION

Install all removed parts in the reverse order of removal.

- Install fuel filter (1), and tighten mounting nuts (2) to the specified torque.

← : Vehicle front

Fuel filter mounting nut:

: 13.5 N·m(1.4 kg-m, 10 ft-lb)

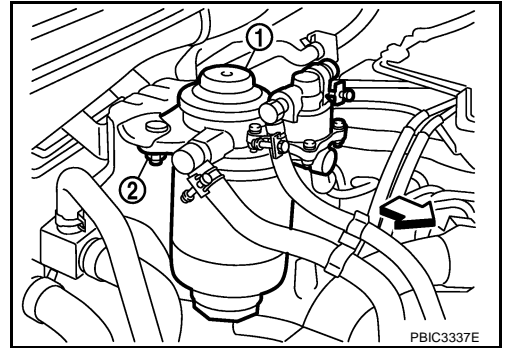
**INSPECTION AFTER INSTALLATION**

1. Check the engine oil level and add engine oil. Refer to [LU-20, "ENGINE OIL"](#) .
2. After warming up engine, check there is no leaks of engine oil.
3. Stop engine and wait for 10 minutes.
4. Check the engine oil level and adjust engine oil level. Refer to [LU-20, "ENGINE OIL"](#) .

A

LU

C

D

E

F

G

H

I

J

K

L

M

OIL COOLER

PFP:21305

Components

GBS0001Y

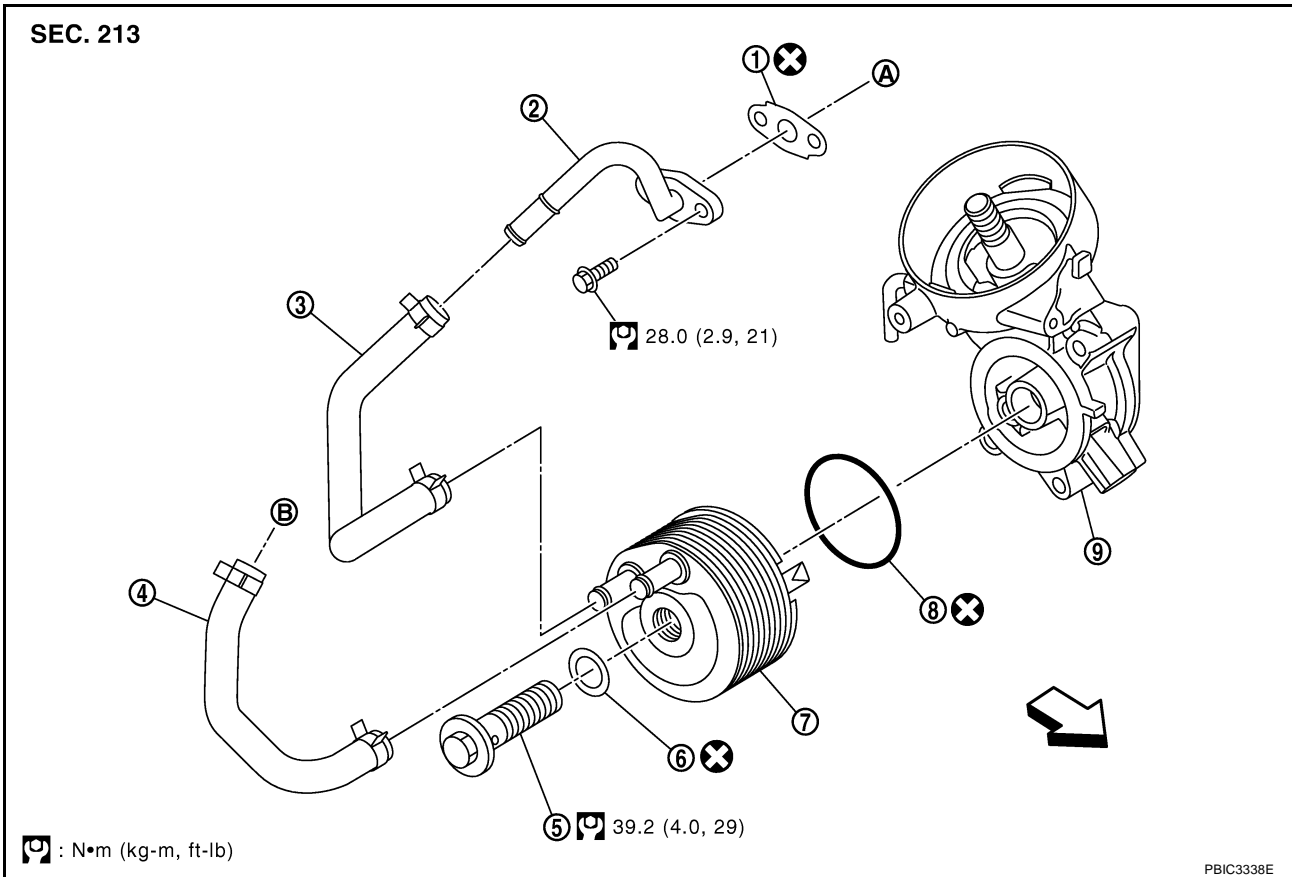

- | | | |
|----------------------|--------------------------|-----------------------|
| 1. Gasket | 2. Water hose connector | 3. Water hose |
| 4. Water hose | 5. Connecting bolt | 6. Washer |
| 7. Oil cooler | 8. O-ring | 9. Oil filter bracket |
| A. To cylinder block | B. To heater return pipe | ⇐ Vehicle front |

- Refer to [GI-10, "Components"](#) for symbol marks except in the above.

Removal and Installation

GBS0001Z

CAUTION:

- Be careful not to get burned when engine oil and engine coolant are hot.
- When removing, prepare a shop cloth to absorb any engine oil and engine coolant leakage or spillage.
- Completely wipe off any engine oil and engine coolant that adhere to engine and vehicle.

REMOVAL

NOTE:

When removing oil cooler only, step 2 is unnecessary.

1. Remove engine undercover front and engine undercover middle. Refer to [EI-15, "FRONT BUMPER"](#) .
2. Drain engine coolant from radiator and cylinder block. Refer to [CO-37, "Changing Engine Coolant"](#) and [EM-254, "CYLINDER BLOCK"](#) .

NOTE:

Perform this step when removing water hoses and water connector.

OIL COOLER

[YD]

3. Remove mounting nuts (2) of fuel filter (1), and move it aside with its hoses connected. Temporarily secure it with a rope to avoid putting load on its hose.

↩ : Vehicle front

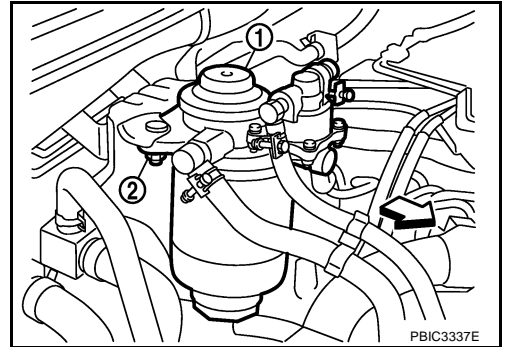

4. Disconnect water hoses from oil cooler.
 - When removing oil cooler only, pinching water hoses near oil cooler to prevent engine coolant spilling.

CAUTION:

- Perform this step when engine is cold.
- Do not spill engine coolant on drive belts.

5. Loosen connecting bolt and remove oil cooler.

CAUTION:

Do not spill engine oil and engine coolant to rubber parts such as drive belts and engine mounting insulator.

6. Remove water hoses and water connector, as necessary.

INSPECTION AFTER REMOVAL

Oil Cooler

Check oil cooler for cracks. Check oil cooler for clogging by blowing through engine coolant inlet. If necessary, replace oil cooler.

INSTALLATION

Installation is the reverse order of removal.

- Make sure that no foreign objects are adhering to the installation planes of oil cooler or oil filter bracket.
- Tighten the connecting bolt after aligning the stopper on the oil filter bracket side with protrusion of oil cooler (1).

A : Align the protrusion and the stopper.

↩ : Vehicle front

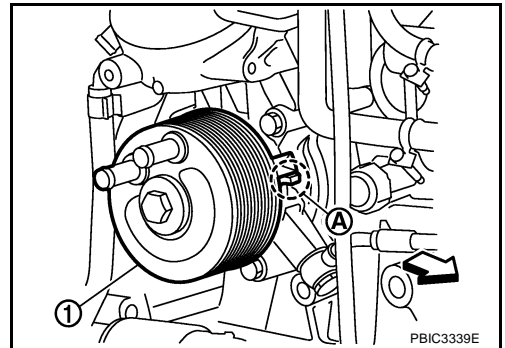

- Install fuel filter (1), and tighten mounting nuts (2) to the specified torque.

↩ : Vehicle front

Fuel filter mounting nut:

: 13.5 N·m(1.4 kg·m, 10 ft·lb)

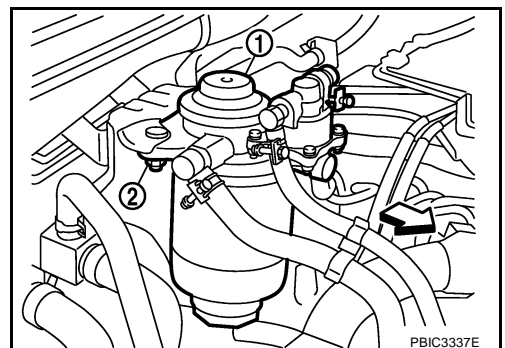

INSPECTION AFTER INSTALLATION

1. Check the engine oil level and the engine coolant level, and add engine oil and engine coolant. Refer to [LU-20, "ENGINE OIL"](#) and [CO-37, "ENGINE COOLANT"](#) .

OIL COOLER

[YD]

2. Start engine, and make sure that there is no leaks of engine oil or engine coolant.
3. Stop engine and wait for 10 minutes.
4. Check the engine oil level and the engine coolant level again. Refer to [LU-20, "ENGINE OIL"](#) and [CO-37, "ENGINE COOLANT"](#).

OIL PUMP

PFP:15010

Removal and Installation

REMOVAL

Remove oil pump housing. Refer to [EM-223, "PRIMARY TIMING CHAIN"](#) .

INSTALLATION

Note the following, and install in the reverse order of removal.

- When installing, align crankshaft flat faces with inner rotor flat faces.

INSPECTION AFTER INSTALLATION

- Check the engine oil level. Refer to [LU-20, "ENGINE OIL"](#) .
- Start engine, and check there is no leaks of engine oil.
- Stop engine and wait for 10 minutes.
- Check the engine oil level and add engine oil. Refer to [LU-20, "ENGINE OIL"](#) .

Components

GBS00021

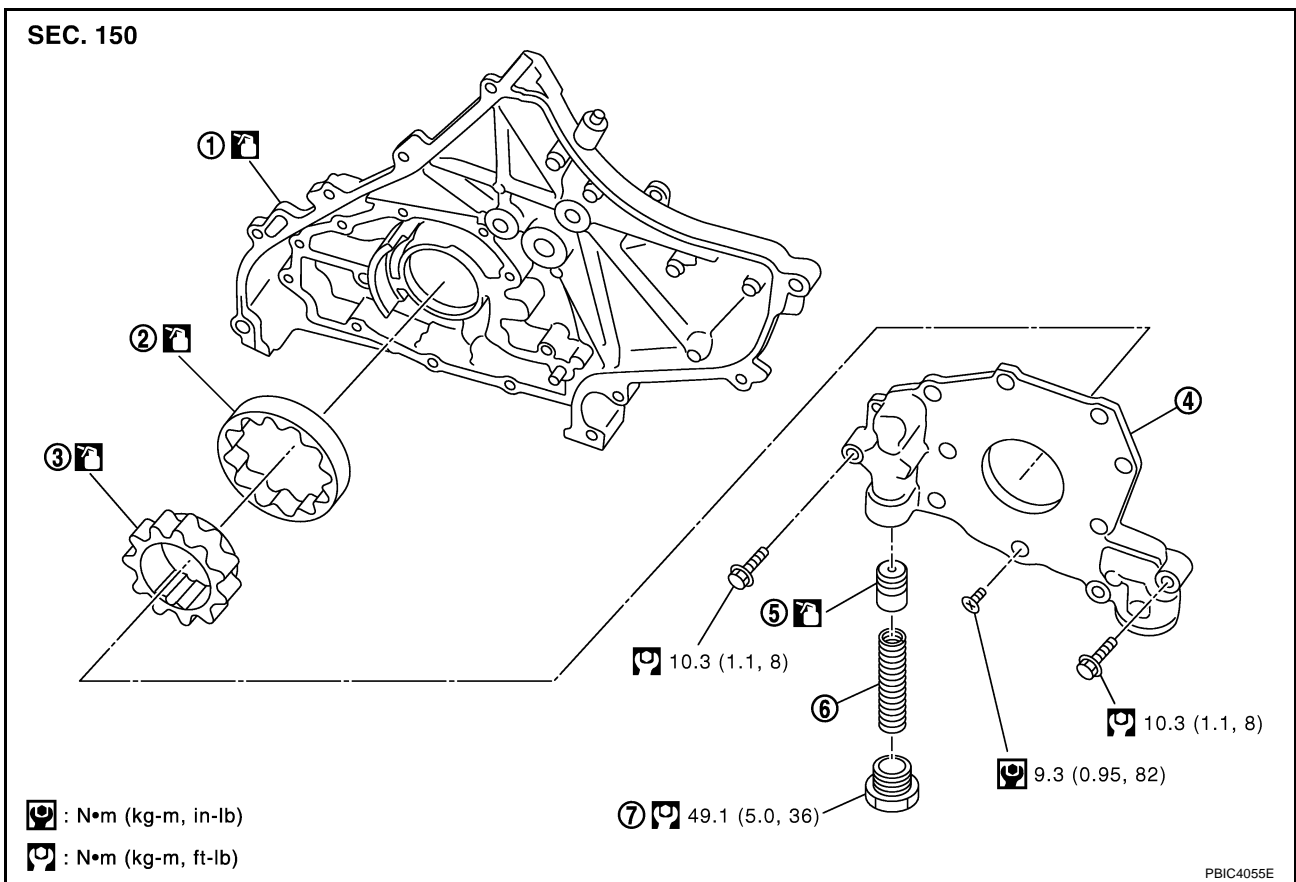

- | | | |
|-------------------------|-------------------------|---------------------------|
| 1. Oil pump housing | 2. Oil pump outer rotor | 3. Oil pump inner rotor |
| 4. Oil pump cover | 5. Regulator valve | 6. Regulator valve spring |
| 7. Regulator valve plug | | |

- Refer to [GI-10, "Components"](#) for symbol marks in the figure.

Disassembly and Assembly

DISASSEMBLY

- Remove oil pump cover.
- Remove oil pump inner rotor and oil pump outer rotor from oil pump housing.
- After removing regulator valve plug, remove inner and outer regulator springs and regulator valve.

GBS00022

INSPECTION AFTER DISASSEMBLY

Oil Pump Clearance

- Measure the clearance with feeler gauge (A).
Clearance between oil pump outer rotor and oil pump housing (position B)

Standard : 0.010 - 0.175 mm (0.0004 - 0.0069 in)

Tip clearance between oil pump inner rotor and oil pump outer rotor (position C)

Standard : 0.060 - 0.180 mm (0.0024 - 0.0071 in)

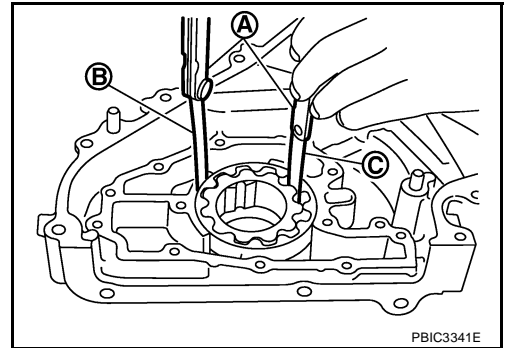

- Measure the clearance with the feeler gauge (C) and the straightedge (A).
Side clearance between oil pump inner rotor and oil pump housing (position B)

Standard : 0.030 - 0.090 mm (0.0012 - 0.0035 in)

Side clearance between oil pump outer rotor and oil pump housing (position D)

Standard : 0.030 - 0.090 mm (0.0012 - 0.0035 in)

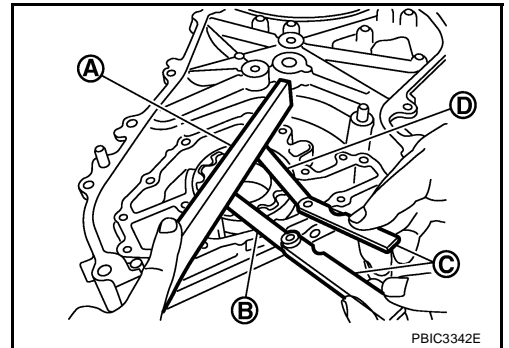

- Calculate the clearance between oil pump inner rotor and oil pump housing as follows.

OIL PUMP HOUSING INNER DIAMETER

- Measure the inner diameter of oil pump housing with the inside micrometer (A).

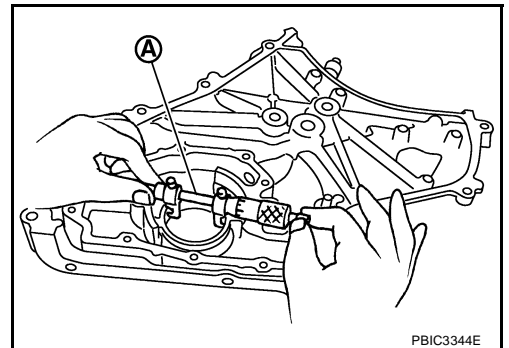

OIL PUMP INNER ROTOR OUTER DIAMETER

- Measure the outer diameter of protruded portion of oil pump inner rotor with a micrometer (A).

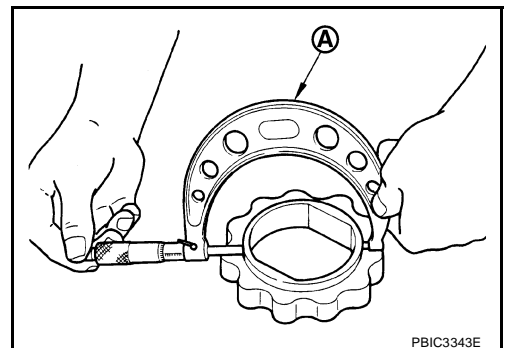

OIL PUMP INNER ROTOR TO OIL PUMP HOUSING CLEARANCE

- (Clearance) = (Oil pump housing inner diameter) – (Oil pump inner rotor outer diameter)

Standard : 0.030 - 0.095mm (0.0012 - 0.0037 in)

- If measured/calculated values are out of the standard, replace oil pump assembly.

Regulator Valve Clearance

Measure the inner diameter of valve hole (oil pump cover) (1) and the outer diameter of regulator valve (2).

- A : Inside micrometer
- B : Micrometer

(Clearance) = (Valve hole diameter) – (Regulator valve outer diameter)

Standard : 0.052 - 0.088 mm (0.0020 - 0.0035 in)

- If the calculated value is out of the standard, replace oil pump assembly.

CAUTION:

- Coat regulator valve with new engine oil.
- Make sure that it falls smoothly into valve hole by its own weight.

ASSEMBLY

Note the following, and assemble in the reverse order of disassembly.

- Install oil pump inner rotor and oil pump outer rotor with the punched marks (A) on the oil pump cover side.

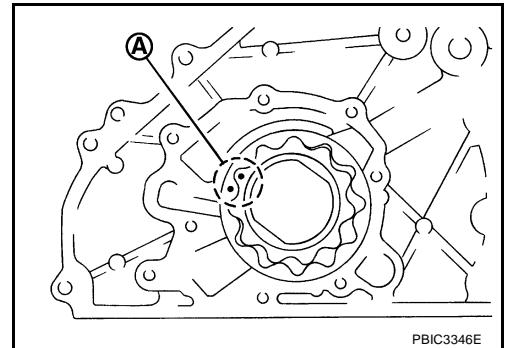
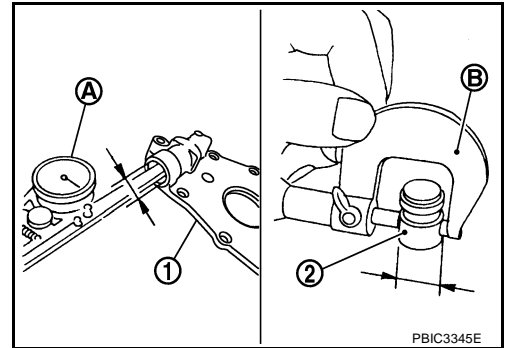

A
 LU
 C
 D
 E
 F
 G
 H
 I
 J
 K
 L
 M

SERVICE DATA AND SPECIFICATIONS (SDS)

[YD]

SERVICE DATA AND SPECIFICATIONS (SDS)

PFP:00030

Standard and Limit OIL PRESSURE

GBS00023

Engine speed rpm	Approximate discharge pressure* kPa (bar, kg/cm ² , psi)
Idle speed	More than 120 (1.20, 1.22, 17.4)
2,000	More than 250 (2.50, 2.55, 36.3)

*: Engine oil temperature at 80°C (176°F)

OIL CAPACITY (APPROXIMATE)

Unit: ℓ · (Imp qt)

Drain and refill	With oil filter change	7.6 (6-5/8)
	Without oil filter change	7.1 (6-1/4)
Dry engine (Overhaul)		7.9 (7)

OIL PUMP

Unit: mm (in)

Oil pump housing to oil pump outer rotor radial clearance	0.010 - 0.175 (0.0004 - 0.0069)
Oil pump inner rotor to oil pump outer rotor tip clearance	0.060 - 0.180 (0.0024 - 0.0071)
Oil pump housing to oil pump inner rotor side clearance	0.030 - 0.090 (0.0012 - 0.0035)
Oil pump housing to oil pump outer rotor side clearance	0.030 - 0.090 (0.0012 - 0.0035)
Oil pump inner rotor to oil pump housing clearance	0.030 - 0.095 (0.0012 - 0.0037)

REGULATOR VALVE

Unit: mm (in)

Regulator valve to oil pump housing clearance	0.052 - 0.088 (0.0020 - 0.0035)
---	---------------------------------