

A  
B  
MT  
D  
E  
F  
G  
H  
I  
J  
K  
L  
M

# SECTION **MT**

## MANUAL TRANSMISSION

### CONTENTS

<p><b>PRECAUTIONS</b> ..... 2</p> <p style="padding-left: 20px;">Service Notice or Precautions ..... 2</p> <p><b>PREPARATION</b> ..... 3</p> <p style="padding-left: 20px;">Special Service Tools ..... 3</p> <p style="padding-left: 20px;">Commercial Service Tools ..... 5</p> <p><b>NOISE, VIBRATION AND HARSHNESS (NVH)</b></p> <p><b>TROUBLESHOOTING</b> ..... 6</p> <p style="padding-left: 20px;">NVH Troubleshooting Chart ..... 6</p> <p><b>DESCRIPTION</b> ..... 7</p> <p style="padding-left: 20px;">Cross-Sectional View ..... 7</p> <p style="padding-left: 40px;">DOUBLE-CONE SYNCHRONIZER ..... 8</p> <p style="padding-left: 40px;">TRIPLE-CONE SYNCHRONIZER ..... 8</p> <p><b>M/T OIL</b> ..... 9</p> <p style="padding-left: 20px;">Changing M/T Oil ..... 9</p> <p style="padding-left: 20px;">DRAINING ..... 9</p> <p style="padding-left: 20px;">FILLING ..... 9</p> <p style="padding-left: 20px;">Checking M/T Oil ..... 9</p> <p style="padding-left: 20px;">OIL LEAKAGE AND OIL LEVEL ..... 9</p> <p><b>REAR OIL SEAL</b> ..... 10</p> <p style="padding-left: 20px;">Removal and Installation ..... 10</p> <p style="padding-left: 40px;">REMOVAL ..... 10</p> <p style="padding-left: 40px;">INSTALLATION ..... 11</p> <p><b>POSITION SWITCH</b> ..... 12</p> <p style="padding-left: 20px;">Checking ..... 12</p> <p style="padding-left: 40px;">BACK-UP LAMP SWITCH ..... 12</p> <p style="padding-left: 40px;">PARK/NEUTRAL POSITION (PNP) SWITCH .... 12</p>	<p><b>SHIFT CONTROL</b> ..... 13</p> <p style="padding-left: 20px;">Removal and Installation ..... 13</p> <p style="padding-left: 40px;">COMPONENTS ..... 13</p> <p style="padding-left: 40px;">REMOVAL ..... 13</p> <p style="padding-left: 40px;">INSTALLATION ..... 13</p> <p style="padding-left: 40px;">INSPECTION AFTER INSTALLATION ..... 14</p> <p><b>AIR BREATHER HOSE</b> ..... 15</p> <p style="padding-left: 20px;">Removal and Installation ..... 15</p> <p><b>TRANSMISSION ASSEMBLY</b> ..... 17</p> <p style="padding-left: 20px;">Removal and Installation from Vehicle ..... 17</p> <p style="padding-left: 40px;">COMPONENTS ..... 17</p> <p style="padding-left: 40px;">REMOVAL ..... 18</p> <p style="padding-left: 40px;">INSTALLATION ..... 19</p> <p style="padding-left: 20px;">Disassembly and Assembly ..... 21</p> <p style="padding-left: 40px;">COMPONENTS ..... 21</p> <p style="padding-left: 40px;">DISASSEMBLY ..... 27</p> <p style="padding-left: 40px;">INSPECTION AFTER DISASSEMBLY ..... 42</p> <p style="padding-left: 40px;">ASSEMBLY ..... 46</p> <p><b>SERVICE DATA AND SPECIFICATIONS (SDS) ..... 69</b></p> <p style="padding-left: 20px;">General Specifications ..... 69</p> <p style="padding-left: 20px;">Gear End Play ..... 70</p> <p style="padding-left: 20px;">Snap Rings ..... 70</p> <p style="padding-left: 20px;">Baulk Ring Clearance ..... 71</p>
--	--

# PRECAUTIONS

---

## PRECAUTIONS

PFP:00001

### Service Notice or Precautions

GCS0000N

- Do not reuse transmission oil, once it has been drained.
- Check oil level or replace oil with vehicle on level surface.
- During removal or installation, keep inside of transmission clear of dust or dirt.
- Check for the correct installation status prior to removal or disassembly. If matching marks are required, be certain they do not interfere with the function of the parts they are applied.
- In principle, tighten bolts or nuts gradually in several steps working diagonally from inside to outside. If tightening sequence is specified, use it.
- Be careful not to damage sliding surfaces and mating surfaces.

# PREPARATION

## PREPARATION

PFP:00002

### Special Service Tools

GCS00000

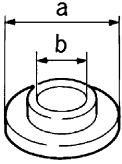
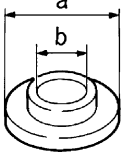
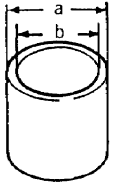
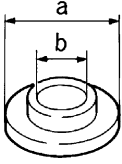
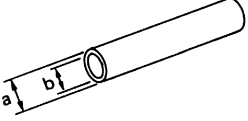
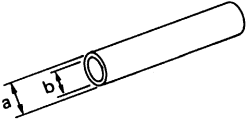
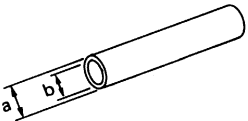
Tool number Tool name	Description
ST30911000 Inserter a: 98 mm (3.86 in) dia. b: 40 mm (1.57 in) dia. <div style="text-align: center;">  <p>ZZA0920D</p> </div>	<ul style="list-style-type: none"> <li>● Installing mainshaft bearing</li> <li>● Installing 5th-6th synchronizer hub assembly</li> <li>● Installing reverse main gear bushing</li> <li>● Installing 3rd gear bushing</li> <li>● Installing 3rd-4th synchronizer hub assembly</li> </ul>
ST30022000 Inserter a: 110 mm (4.33 in) dia. b: 46 mm (1.81 in) dia. <div style="text-align: center;">  <p>ZZA0920D</p> </div>	<ul style="list-style-type: none"> <li>● Installing 3rd main gear</li> <li>● Installing 4th main gear</li> </ul>
ST27861000 Support ring a: 62 mm (2.44 in) dia. b: 52 mm (2.05 in) dia. <div style="text-align: center;">  <p>ZZA0832D</p> </div>	<ul style="list-style-type: none"> <li>● Installing 1st-2nd synchronizer hub assembly</li> <li>● Installing 1st gear bushing</li> </ul>
ST30032000 Inserter a: 80 mm (3.15 in) dia. b: 31 mm (1.22 in) dia. <div style="text-align: center;">  <p>ZZA0920D</p> </div>	Installing counter rear bearing inner race
KV32102700 Drift a: 48 mm (1.89 in) dia. b: 41 mm (1.61 in) dia. <div style="text-align: center;">  <p>ZZA0534D</p> </div>	Installing main drive gear bearing
ST23860000 Drift a: 38 mm (1.50 in) dia. b: 33 mm (1.30 in) dia. <div style="text-align: center;">  <p>ZZA0534D</p> </div>	Installing reverse counter gear
ST01530000 Drift a: 50 mm (1.97 in) dia. b: 41 mm (1.61 in) dia. <div style="text-align: center;">  <p>ZZA0534D</p> </div>	Installing reverse synchronizer hub assembly

A  
B  
MT  
D  
E  
F  
G  
H  
I  
J  
K  
L  
M

# PREPARATION

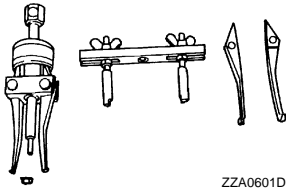
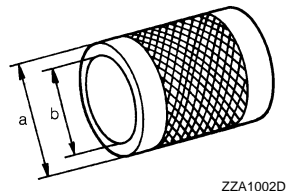
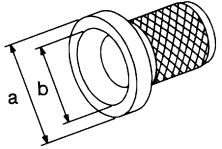
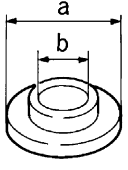
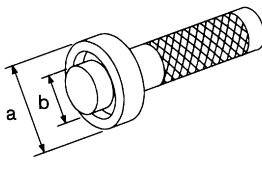
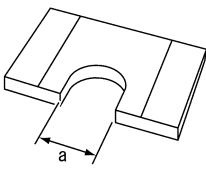
Tool number Tool name	Description
KV381054S0 Puller <div style="text-align: center;">  <p style="text-align: right; font-size: small;">ZZA0601D</p> </div>	Removing rear oil seal
ST33200000 Drift a: 60 mm (2.36 in) dia. b: 44.5 mm (1.752 in) dia. <div style="text-align: center;">  <p style="text-align: right; font-size: small;">ZZA1002D</p> </div>	<ul style="list-style-type: none"> <li>● Installing counter rear bearing</li> <li>● Installing rear oil seal</li> </ul>
KV38100500 Drift a: 80 mm (3.15 in) dia. b: 60 mm (2.36 in) dia. <div style="text-align: center;">  <p style="text-align: right; font-size: small;">S-NT086</p> </div>	Installing dust seal (for 2WD models)
KV40100630 Inserter a: 67 mm (2.64 in) dia. b: 38 mm (1.50 in) dia. <div style="text-align: center;">  <p style="text-align: right; font-size: small;">ZZA0920D</p> </div>	Installing 4th counter gear thrust washer
KV38102100 Drift a: 44 mm (1.73 in) dia. b: 28 mm (1.10 in) dia. <div style="text-align: center;">  <p style="text-align: right; font-size: small;">NT084</p> </div>	Installing front cover oil seal
KV32103300 Press plate a: 73 mm (2.87 in) <div style="text-align: center;">  <p style="text-align: right; font-size: small;">PCIB0165J</p> </div>	Installing reverse synchronizer hub assembly

# PREPARATION

Tool number Tool name	Description
ST30031000 Puller	Measuring wear of inner baulk ring
ST22490000 Adapter setting plate	Holding a adapter plate

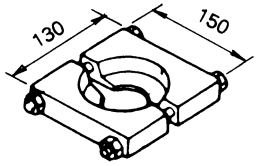

ZZC0499D

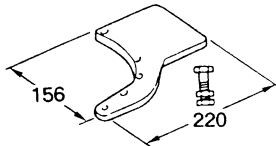

ZZC0465D

## Commercial Service Tools

GCS0000P

Tool name	Description
Puller	Removing each bearing, gear and bushing
Pin punch Tip diameter: 6.0 mm (0.236 in) dia.	Removing and installing each retaining pin
Puller	<ul style="list-style-type: none"> <li>● Removing reverse synchronizer hub assembly</li> <li>● Removing reverse main gear</li> <li>● Removing reverse counter gear</li> </ul>
Drift a: 32 mm (1.26 in) dia.	Installing counter end bearing
Puller	Removing counter end bearing

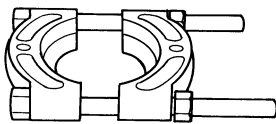

ZZB0823D



ZZA0815D

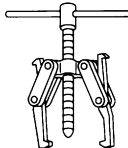

NT077

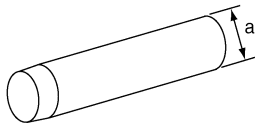

LCIA0362E



S-NT134

# NOISE, VIBRATION AND HARSHNESS (NVH) TROUBLESHOOTING

## NOISE, VIBRATION AND HARSHNESS (NVH) TROUBLESHOOTING

PFP:00003

### NVH Troubleshooting Chart

GCS00000

Use the chart below to help you find the cause of the symptom. The numbers indicate the order of the inspection. If necessary, repair or replace these parts.

Reference page		MT-9			MT-21		MT-13	MT-25		MT-23			
SUSPECTED PARTS (Possible cause)		OIL (Oil level is low.)	OIL (Wrong oil.)	OIL (Oil level is high.)	GASKET (Damaged)	OIL SEAL (Worn or damaged)	SHIFT CONTROL LINKAGE (Worn)	CHECK PLUG RETURN SPRING AND CHECK BALL (Worn or damaged)	SHIFT FORK (Worn)	GEAR (Worn or damaged)	BEARING (Worn or damaged)	BAULK RING (Worn or damaged)	INSERT SPRING (Damaged)
Symptoms	Noise	1	2							3	3		
	Oil leakage		3	1	2	2							
	Hard to shift or will not shift		1	1			2					2	2
	Jumps out of gear						1	1	2	2			

# DESCRIPTION

## DESCRIPTION

PPF:00000

### Cross-Sectional View

GCS0000R

A  
B  
MT  
D  
E  
F  
G  
H  
I  
J  
K  
L  
M

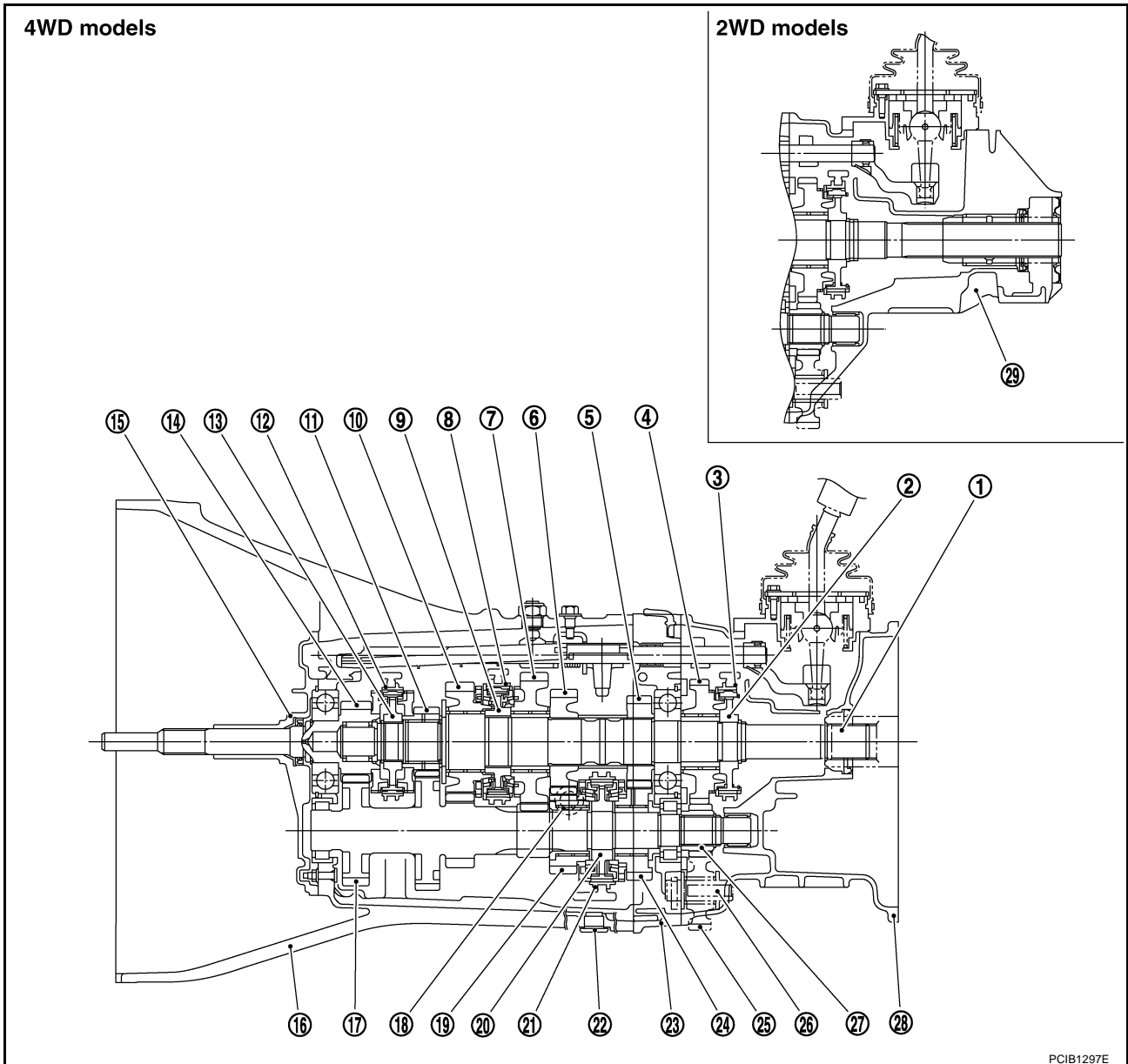

PCIB1297E

- |                              |                              |                             |
|------------------------------|------------------------------|-----------------------------|
| 1. Mainshaft                 | 2. Reverse synchronizer hub  | 3. Reverse coupling sleeve  |
| 4. Reverse main gear         | 5. 4th main gear             | 6. 3rd main gear            |
| 7. 1st main gear             | 8. 1st-2nd coupling sleeve   | 9. 1st-2nd synchronizer hub |
| 10. 2nd main gear            | 11. 6th main gear            | 12. 5th-6th coupling sleeve |
| 13. 5th-6th synchronizer hub | 14. Main drive gear          | 15. Front cover             |
| 16. Transmission case        | 17. Counter gear             | 18. Filler plug             |
| 19. 3rd counter gear         | 20. 3rd-4th synchronizer hub | 21. 3rd-4th coupling sleeve |
| 22. Drain plug               | 23. Adapter plate            | 24. 4th counter gear        |
| 25. Reverse idler gear       | 26. Reverse idler shaft      | 27. Reverse counter gear    |
| 28. OD gear case             | 29. Rear extension           |                             |

# DESCRIPTION

## DOUBLE-CONE SYNCHRONIZER

The 1st, 3rd and 4th gears is equipped with a double-cone synchronizer to reduce the operating force of the shift lever.

## TRIPLE-CONE SYNCHRONIZER

The 2nd gear is equipped with a triple-cone synchronizer to reduce the operating force of the shift lever.

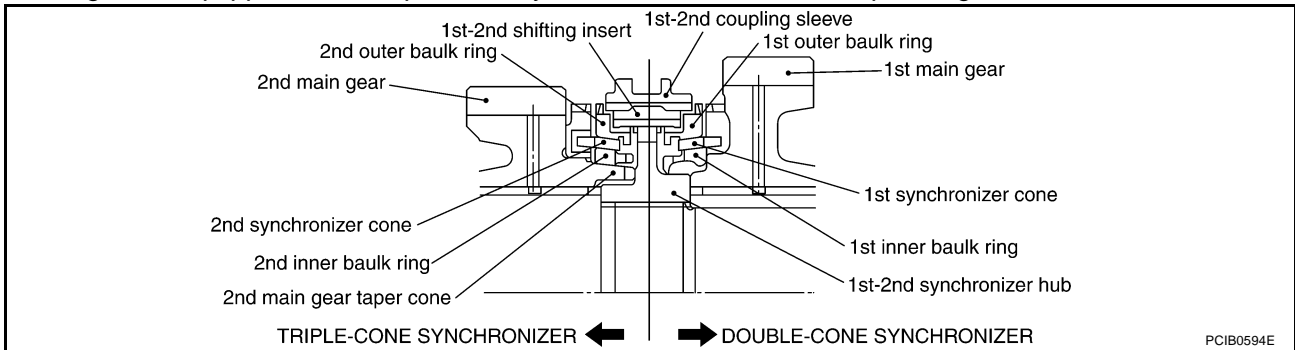



## M/T OIL

PFP:KLD20

### Changing M/T Oil DRAINING

GCS0000S

1. Start engine and let it run to warm up transmission.
2. Stop engine. Remove drain plug and gasket and then drain oil.
3. Set a gasket on drain plug and install it to transmission case. Tighten drain plug to the specified torque. Refer to [MT-21, "Case Components"](#) .

**CAUTION:**

**Do no reuse gasket.**

### FILLING

1. Remove filler plug and gasket. Fill with new oil until oil level reaches the specified limit near filler plug mounting hole.

**Oil grade and viscosity:** Refer to [MA-13, "Fluids and Lubricants"](#) .

**Oil capacity**

**VQ engine models**

**2WD models:** Approx. 3.98 ℓ (7 Imp pt)

**4WD models:** Approx. 4.18 ℓ (7-3/8 Imp pt)

**YD engine models**

**2WD models:** Approx. 3.99 ℓ (7 Imp pt)

**4WD models:** Approx. 4.32 ℓ (7-5/8 Imp pt)

2. After refilling oil, check oil level. Set a gasket to filler plug, then install it to transmission case. Tighten filler plug to the specified torque. Refer to [MT-21, "Case Components"](#) .

**CAUTION:**

**Do no reuse gasket.**

### Checking M/T Oil

#### OIL LEAKAGE AND OIL LEVEL

GCS0000T

- Make sure that oil is not leaking from transmission or around it.
- Check oil level from filler plug mounting hole as shown in the figure.

**CAUTION:**

**Do not start engine while checking oil level.**

- Set a gasket on filler plug and install it to transmission case. Tighten filler plug to the specified torque. Refer to [MT-21, "Case Components"](#) .

**CAUTION:**

**Do not reuse gasket.**

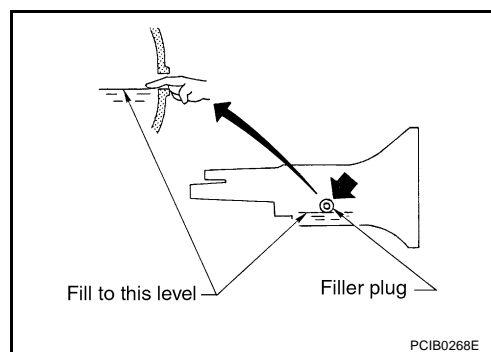

# REAR OIL SEAL

## REAR OIL SEAL

PFP:33140

### Removal and Installation REMOVAL

GCS0000U

#### For 2WD Models

1. Remove rear propeller shaft. Refer to [PR-8, "Removal and Installation"](#) .
2. Remove dust seal and rear oil seal using a suitable tool.

**CAUTION:**

**Do not damage rear extension.**

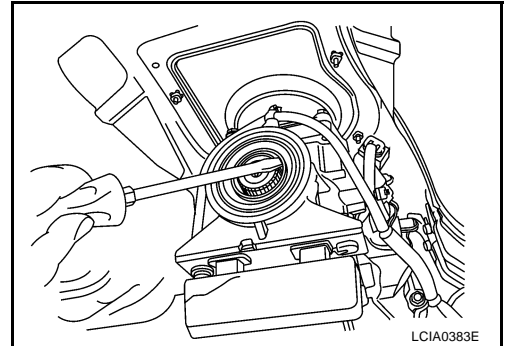

#### For 4WD Models

1. Remove front and rear propeller shafts. Refer to [PR-4, "Removal and Installation"](#) (front) and [PR-8, "Removal and Installation"](#) (rear).
2. Remove transfer assembly. Refer to [TF-116, "Removal and Installation"](#) .
3. Remove rear oil seal using the drift.

**CAUTION:**

**Do not damage OD gear case.**

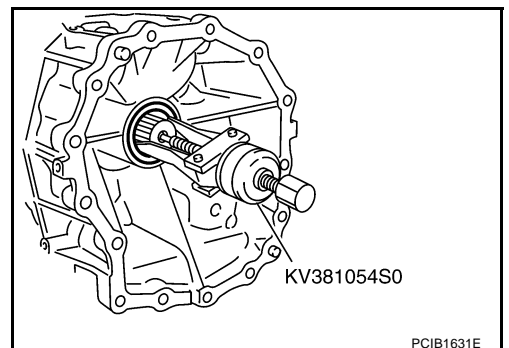

# REAR OIL SEAL

## INSTALLATION

Note the following, and install in the reverse order of removal.

- **For 2WD models**

Drive the rear oil seal (1) and dust seal (2) using the drift.

**CAUTION:**

**Do not incline the dust seal and rear oil seal during installation.**

**Tool number**

**For oil seal : ST33200000**

**For dust seal : KV38100500**

**Dimension "H1" : 1.2 - 2.2 mm (0.047 - 0.087 in)**

**Dimension "H2" : 0.5 - 1.5 mm (0.020 - 0.059 in)**

(A): Seal lip

- **For 4WD models**

Drive the rear oil seal using the drift.

**Tool number : ST33200000**

**Dimension "A" : -0.5 - 0.5 mm (-0.020 - 0.020 in)**

**CAUTION:**

**Do not incline the rear oil seal during installation.**

- Check the transmission oil level after installation. Refer to [MT-9](#), "[Checking M/T Oil](#)".

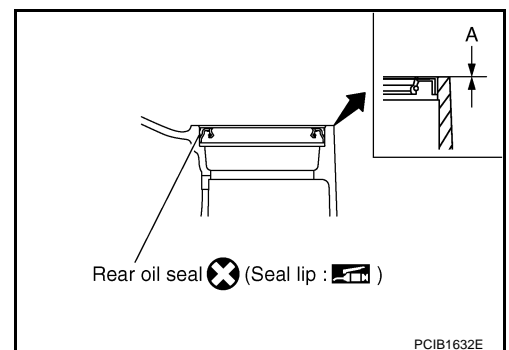
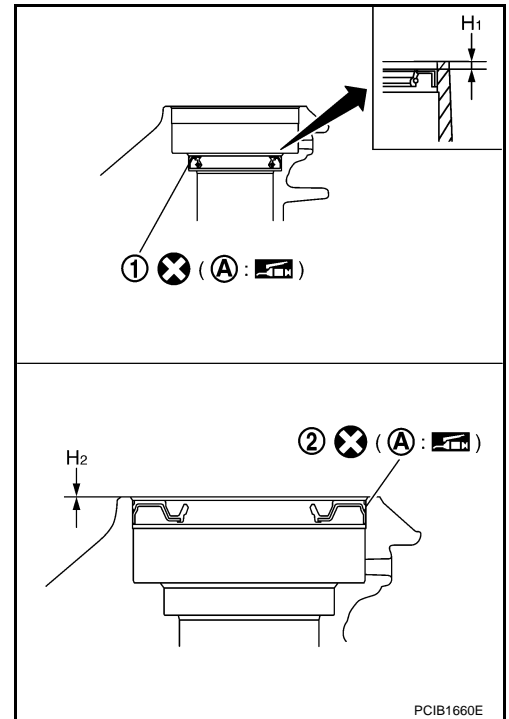

A  
B  
MT  
D  
E  
F  
G  
H  
I  
J  
K  
L  
M

# POSITION SWITCH

PFP:32005

GCS0000V

## POSITION SWITCH

### Checking BACK-UP LAMP SWITCH

- Check continuity.

Gear position	Continuity
Reverse	Yes
Except reverse	No

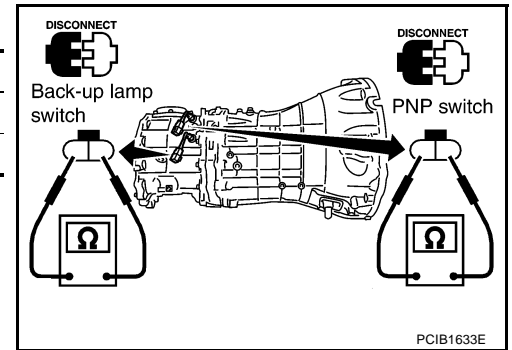

### PARK/NEUTRAL POSITION (PNP) SWITCH

- Check continuity.

Gear position	Continuity
Neutral	Yes
Except neutral	No

# SHIFT CONTROL

PFP:34103

A  
B  
MT  
D  
E  
F  
G  
H  
I  
J  
K  
L  
M

## SHIFT CONTROL

### Removal and Installation COMPONENTS

GCS0000W

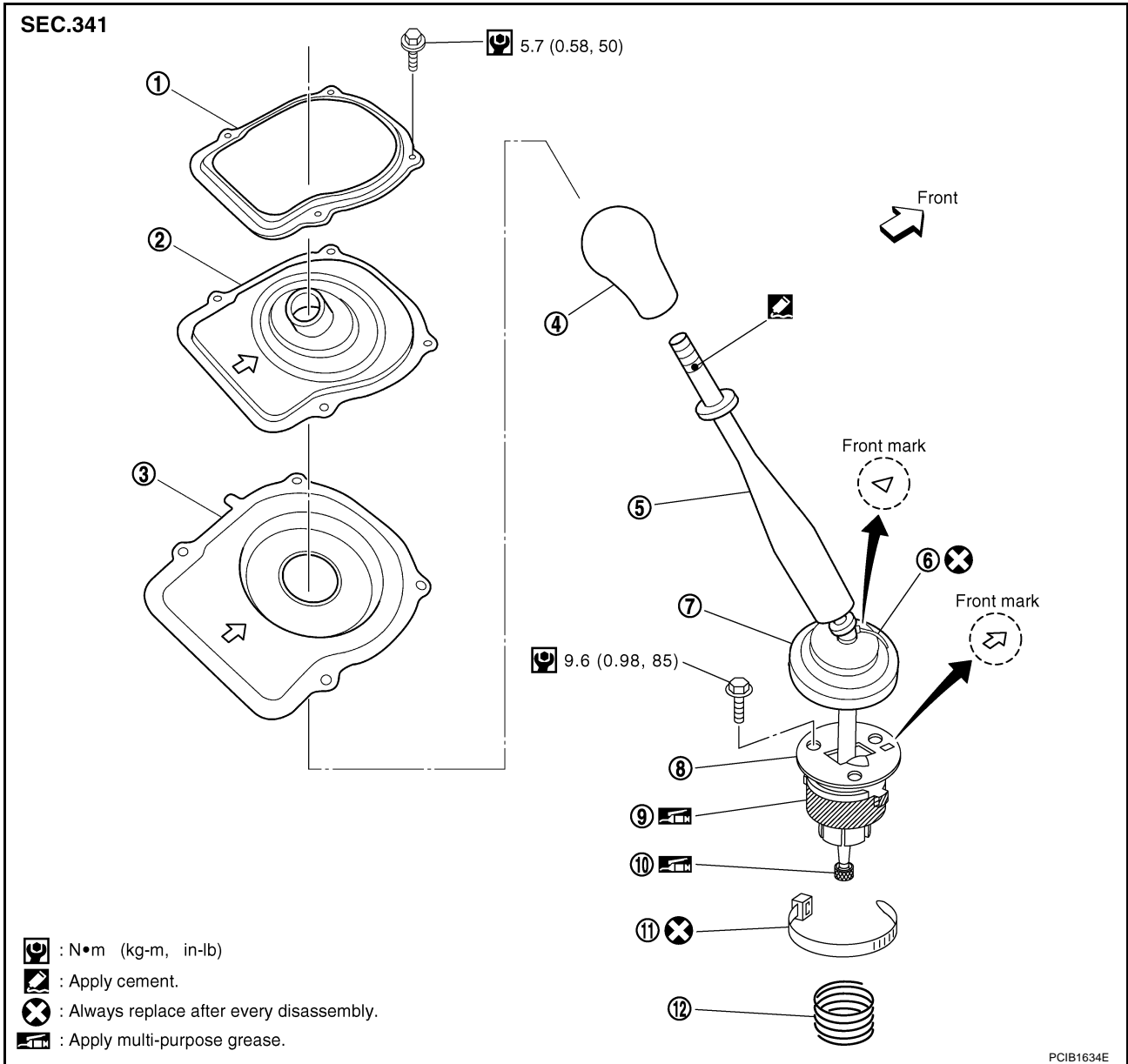

- |               |                           |              |
|---------------|---------------------------|--------------|
| 1. Cover      | 2. Control lever boot     | 3. Insulator |
| 4. Shift knob | 5. Control lever assembly | 6. Clip (A)  |
| 7. Boot       | 8. Guide plate            | 9. Socket    |
| 10. Bushing   | 11. Clip (B)              | 12. Spring   |

### REMOVAL

1. Remove console boot. Refer to [IP-14, "CONSOLE BOOT M/T"](#).
2. Remove shift knob.
3. Remove cover mounting bolts and then remove cover, control lever boot and insulator.
4. Remove clip (B) and then separate boot from control housing.
5. Remove guide plate mounting bolts and then separate guide plate.
6. Remove control lever assembly and spring from the transmission.

### INSTALLATION

Note the following, and install in the reverse order of removal.

# SHIFT CONTROL

- Install shift knob according to the following.
- Apply cement to threads of control lever assembly.
- Tightening shift knob until reacting. Then align shift knob to the position as shown in the figure within one turn.

**CAUTION:**

**Do not adjust shift knob with loosening.**

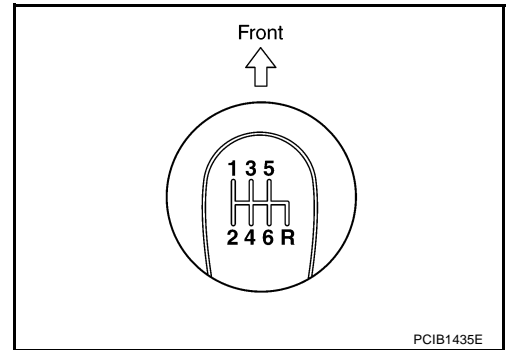

**CAUTION:**

- Insert bushing of control lever assembly to the hole of striking arm as far as bushing goes.
- Apply multi-purpose grease to socket and bushing.
- Be careful with the orientation guide plate and boot.
- Tighten guide plate (1) mounting bolts to the specified torque in order as shown on the figure. Refer to [MT-13, "COMPONENTS"](#).

←: Front

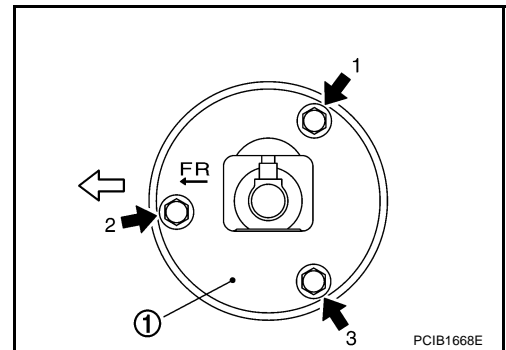

- Be careful with the orientation clip.
- Do not reuse clip.
- Be careful with the orientation control lever boot and insulator.

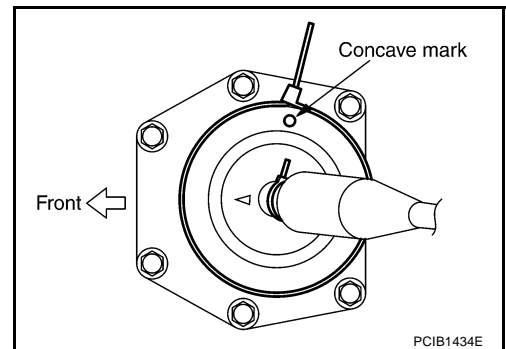

## INSPECTION AFTER INSTALLATION

After installing, confirm the following items:

- When control lever assembly is shifted to each position, make sure there is no binding or disconnection in each boot.
- When shifted to each position, make sure there is no noise, catching, and backlash. Especially when control lever assembly is shifted to 5th, 6th without pressing downward, check for catching.
- When control lever assembly is shifted to 1st, 2nd side and 5th, 6th side, confirm control lever assembly returns to neutral position smoothly.
- In any position other than reverse, confirm that control lever assembly can be pressed downward.
- With control lever assembly pressed downward, confirm that it can be shifted to reverse.
- When shifted from reverse to neutral position, confirm control lever assembly returns to neutral position smoothly with spring power.
- Without control lever assembly pressed downward, confirm that it cannot be shifted to reverse.

# AIR BREATHER HOSE

PFP:31098

## AIR BREATHER HOSE Removal and Installation

GCS0000X

Refer to the figure below for air breather hose removal and installation information.

### VQ engine models

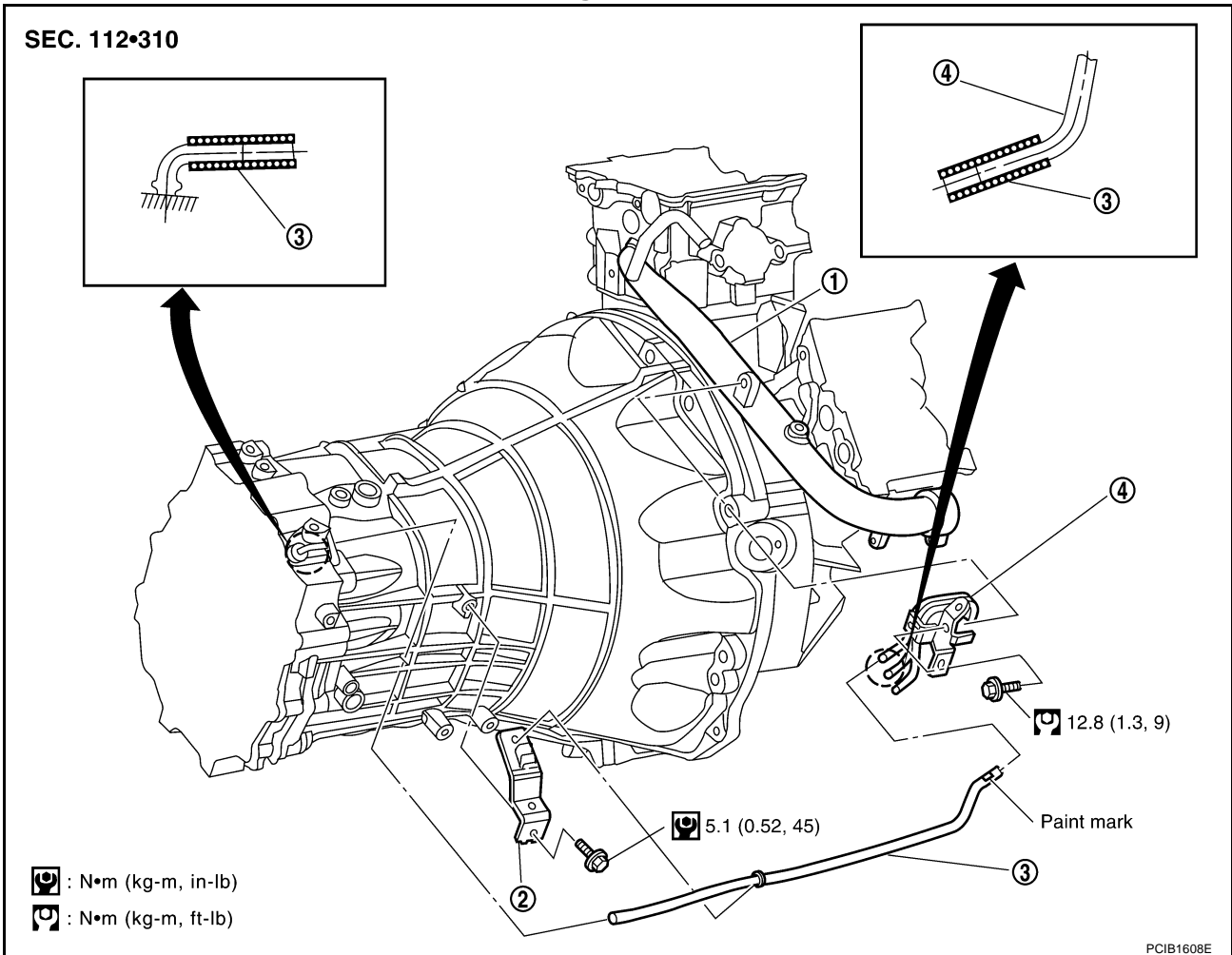

A  
B  
MT  
D  
E  
F  
G  
H  
I  
J  
K  
L  
M

# AIR BREATHER HOSE

YD engine models

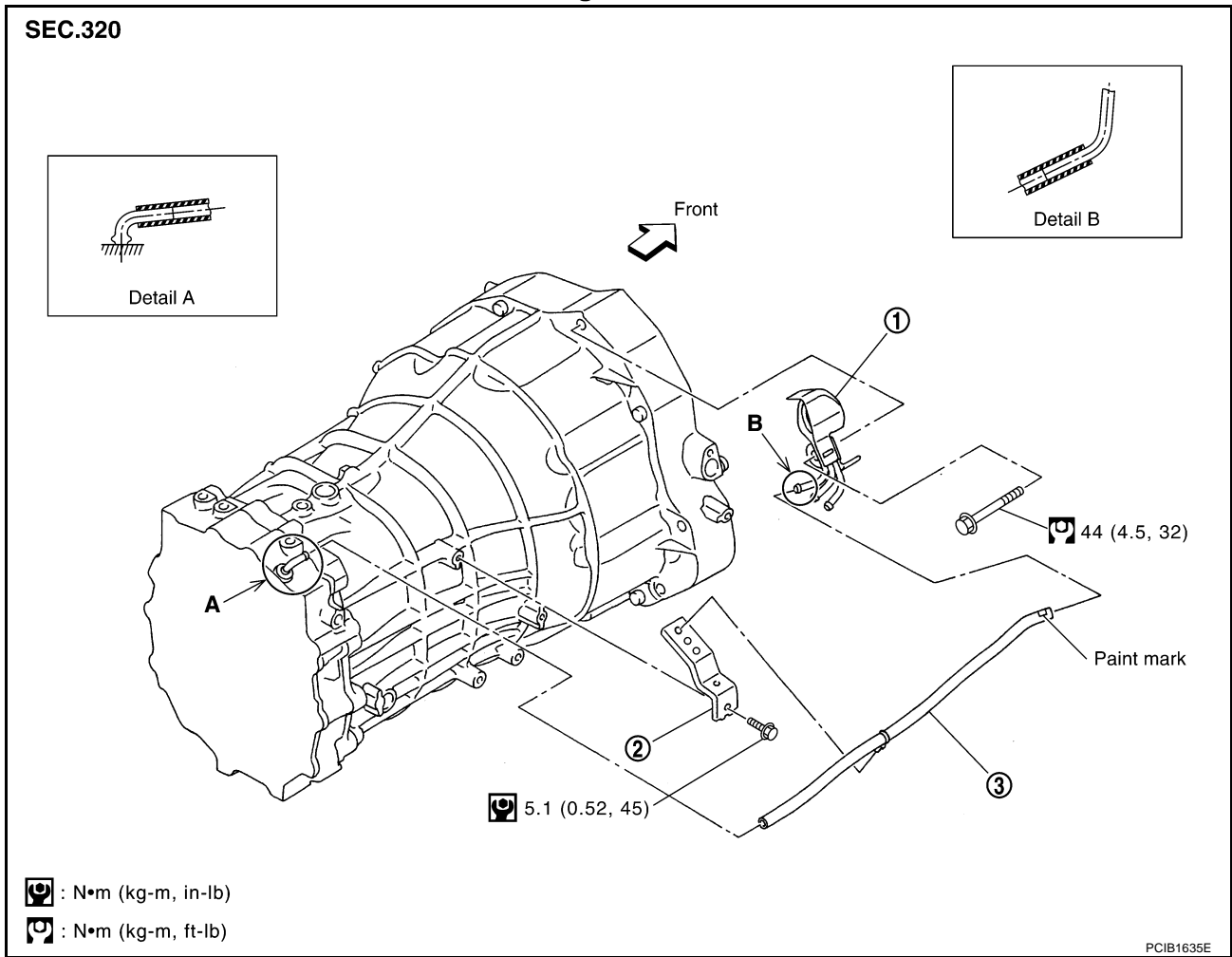

1. Breather tube

2. Bracket

3. Air breather hose

- For removal and installation transfer air breather hose and actuator/transfer motor breather hose, refer to [TF-112, "Removal and Installation"](#).

## CAUTION:

- Make sure there are no pinched or restricted areas on air breather hose caused by bending or winding when installing it.
- Install air breather hose into breather until the hose end reaches the end of the curved section.
- Install air breather hose into breather tube until the hose end reaches the end of the curved section.
- Install air breather hose with the paint mark side up.



# TRANSMISSION ASSEMBLY

## TRANSMISSION ASSEMBLY

PFP:32010

### Removal and Installation from Vehicle COMPONENTS

GCS0000Y

#### 2WD models

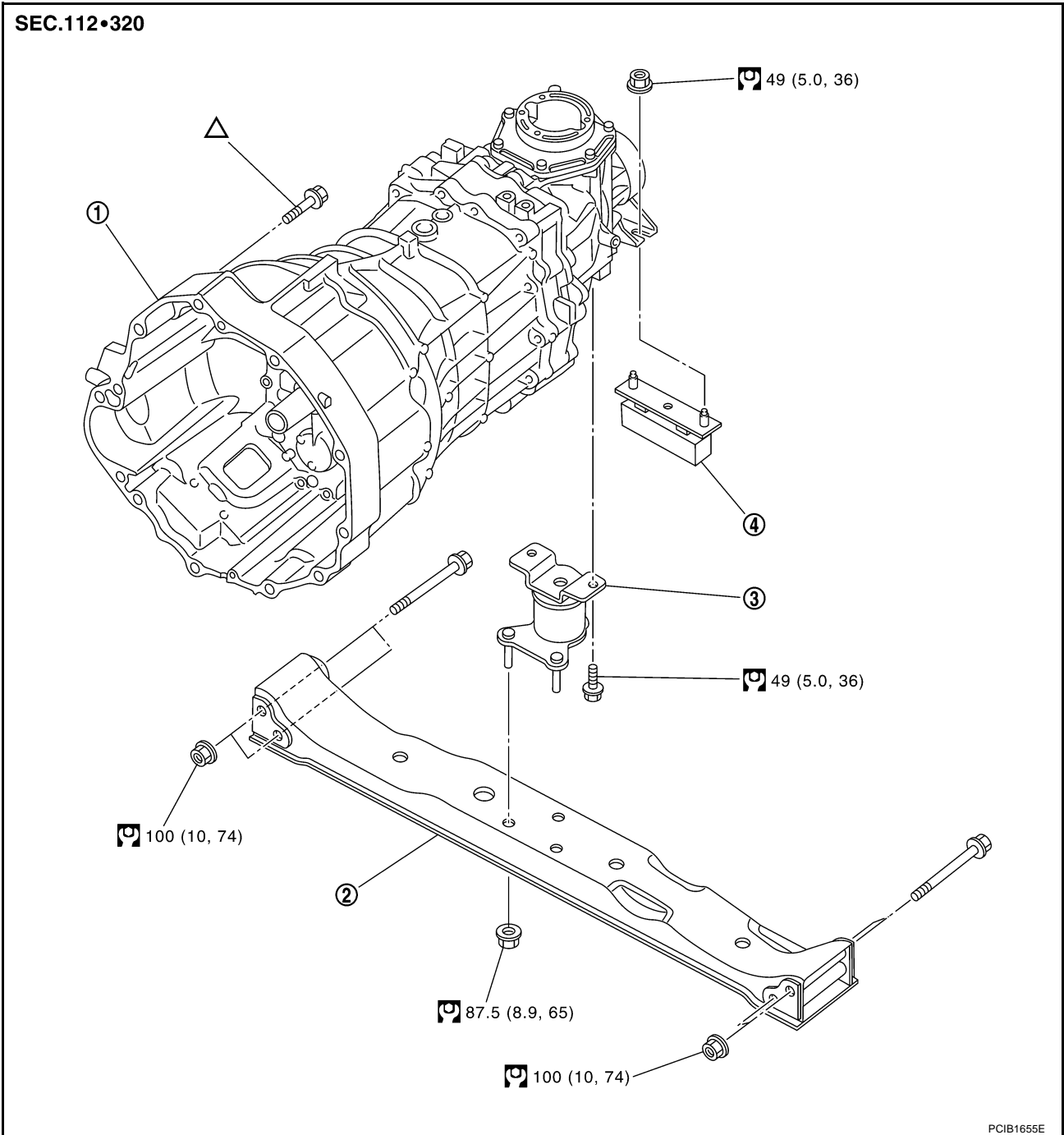

1. Transmission assembly
2. Transmission cross member
3. Insulator
4. Dynamic damper

△: Refer to [MT-19, "INSTALLATION"](#) for the tightening torque.

Refer to [GI-10, "Components"](#), for the symbols in the figure.

A  
B  
MT  
D  
E  
F  
G  
H  
I  
J  
K  
L  
M

# TRANSMISSION ASSEMBLY

4WD models

SEC.112•320

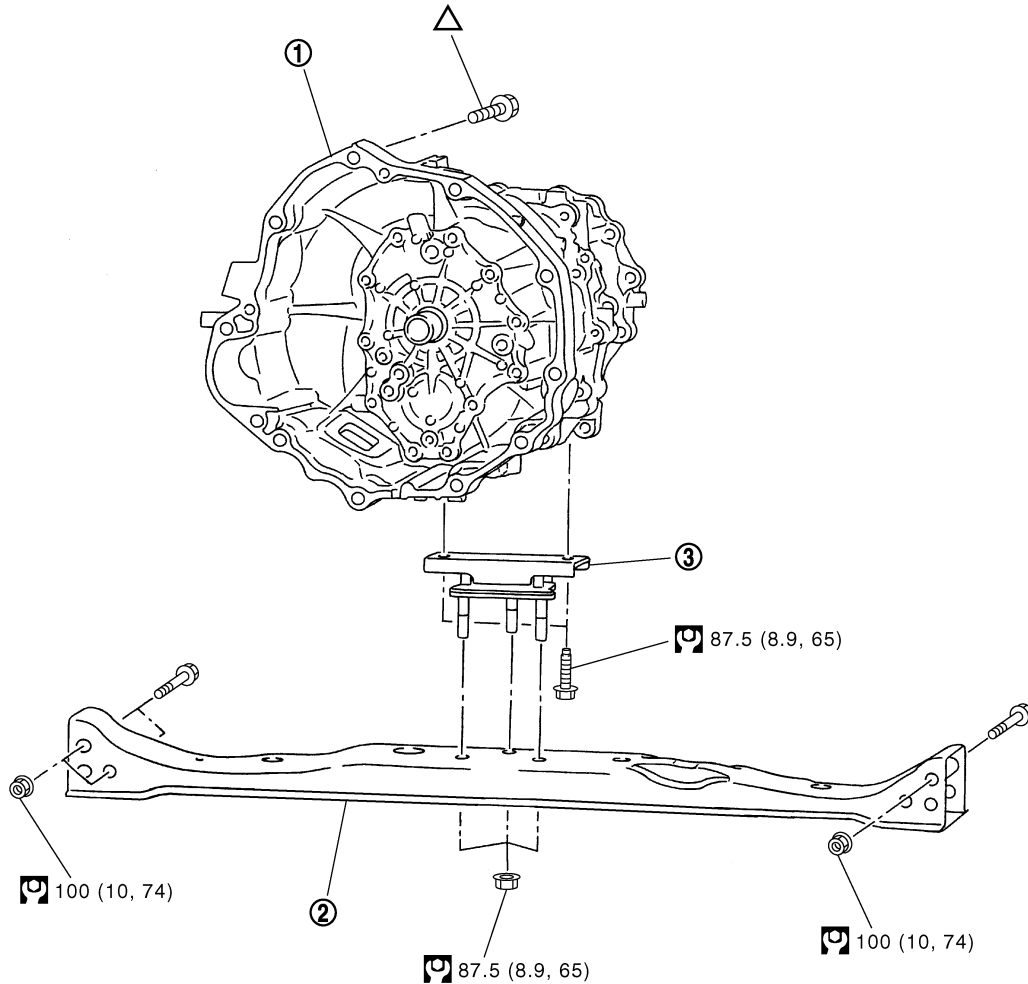

 : N•m (kg-m, ft-lb)

 : Refer to "INSTALLATION" for the tightening torque.

PCIB1609E

1. Transmission assembly

2. Transmission cross member

3. Insulator

## REMOVAL

1. Disconnect the battery cable from the negative terminal.
2. Drain gear oil, if remove transfer assembly. Refer to [MT-9, "Changing M/T Oil"](#) .
3. Remove control lever assembly. Refer to [MT-13, "Removal and Installation"](#) .
4. Remove engine under cover middle and engine under cover rear.
5. Remove main muffler and tail tube. Refer to [EX-3, "Removal and Installation"](#) .
6. Remove front propeller shaft (for 4WD models) and rear propeller shaft. Refer to [PR-4, "Removal and Installation"](#) (front) and [PR-8, "Removal and Installation"](#) (rear).

### CAUTION:

Be careful not to damage spline, sleeve yoke and rear oil seal of transfer, when removing propeller shaft.

### NOTE:

Insert a suitable plug into rear oil seal of transfer after removing propeller shaft.

7. Remove clutch operating cylinder. Refer to [CL-12, "Removal and Installation"](#) .

### CAUTION:

Do not depress clutch pedal during removal procedure.

# TRANSMISSION ASSEMBLY

8. Remove crankshaft position sensor (POS) from transmission assembly.

**CAUTION:**

- Avoid impacts such as a dropping.
- Do not disassemble.
- Keep it away from metal particles.
- Do not place the sensor in a location where it is exposed to magnetism.

9. Remove starter motor. Refer to [SC-36, "Removal and Installation"](#) .

10. Disconnect the following switch connectors:

● **For transmission assembly**

- Back-up lamp switch
- Park/neutral position (PNP) switch

● **For transfer assembly (For 4WD models)**

- ATP switch
- Neutral 4LO switch or 4LO switch
- Wait detection switch
- Transfer control device
- Transfer motor (For YD engine models)
- Transfer terminal cord assembly (For YD engine models)
- Front revolution sensor (For VQ engine without ABS models)

11. Support transmission assembly with a jack.

**CAUTION:**

**When setting a jack, be careful not to bring it into contact with switches.**

12. Remove air breather hose. Refer to [MT-15, "Removal and Installation"](#) .

13. Remove protector (fuel tube), and then disconnect fuel tubes (for 4WD models). Refer to [FL-19, "Removal and Installation \(4WD Models Only\)"](#) .

14. Remove insulator mounting nuts.

15. Remove transmission cross member and insulator.

16. Remove transmission assembly mounting bolts.

17. Remove transmission assembly from the vehicle.

**CAUTION:**

**Secure transmission assembly to a jack while removing it.**

18. Remove transfer assembly (for 4WD models). Refer to [TF-116, "Removal and Installation"](#) .

19. Remove release bearing sleeve assembly and withdrawal lever, if necessary. Refer to [CL-15, "Removal and Installation"](#) .

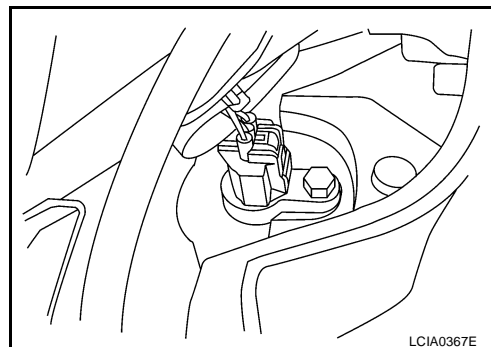

A

B

MT

D

E

F

G

H

I

J

K

L

M

## INSTALLATION

Note the following, and install in the reverse order of removal.

- Tighten the bolts to the specified torque.

- **VQ engine models**

**Bolt length "ℓ":** 65 mm (2.56 in)

**Tightening torque:** 75 N·m (7.7 kg·m, 55 lb·ft)

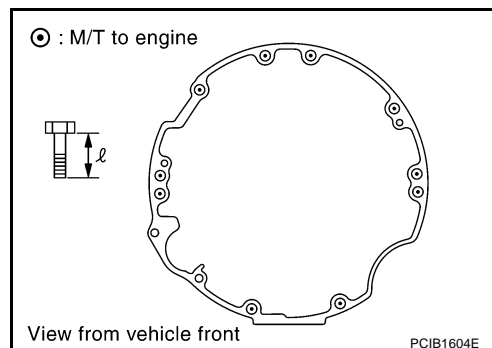

# TRANSMISSION ASSEMBLY

## YD engine models

**Bolt length “ $\ell$ ”:** 85 mm (3.35 in)

**Tightening torque:** 44 N·m (4.5 kg·m, 32 lb·ft)

### CAUTION:

- When installing transmission assembly, be careful not to bring main drive gear into contact with clutch cover.
- After installation, check for oil leakage and oil level. Refer to [MT-9, "OIL LEAKAGE AND OIL LEVEL"](#).
- If flywheel is removed, align dowel pin with the smallest hole of flywheel. Refer to [EM-111, "ASSEMBLY"](#) (VQ engine models) or [EM-258, "ASSEMBLY"](#) (YD engine models).

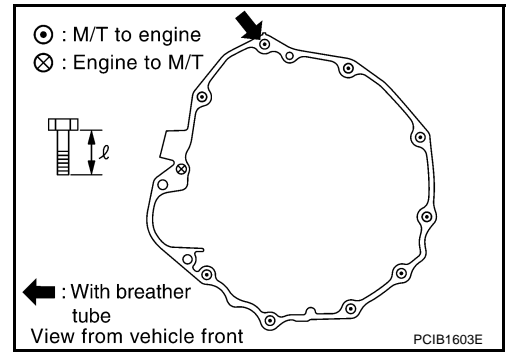

# TRANSMISSION ASSEMBLY

GCS0000Z

## Disassembly and Assembly COMPONENTS Case Components

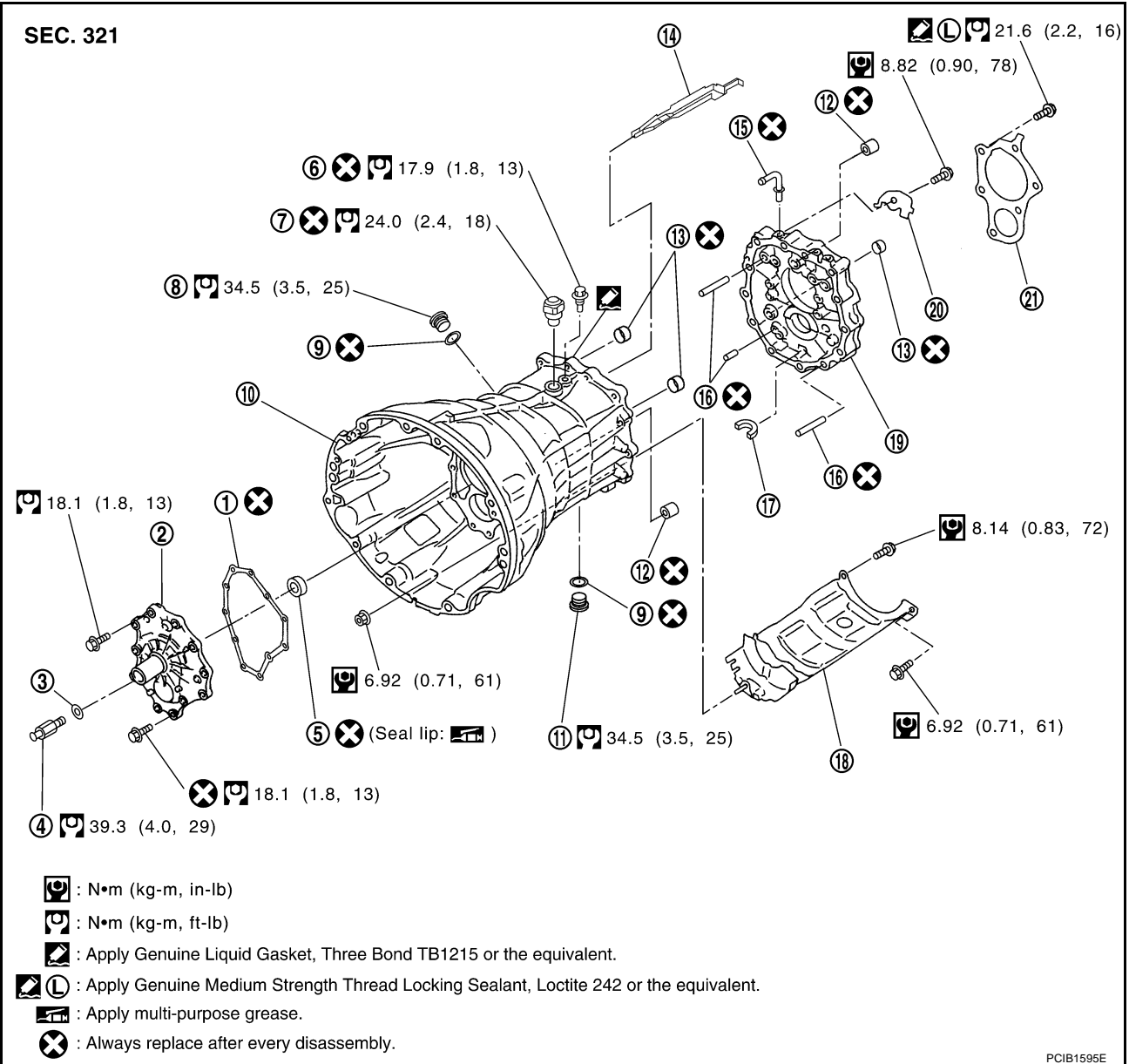

- |                              |                         |                          |
|------------------------------|-------------------------|--------------------------|
| 1. Front cover gasket        | 2. Front cover          | 3. Washer                |
| 4. Withdrawal lever ball pin | 5. Front cover oil seal | 6. Pivot bolt            |
| 7. Check shift pin           | 8. Filler plug          | 9. Gasket                |
| 10. Transmission case        | 11. Drain plug          | 12. Sliding ball bearing |
| 13. Bushing                  | 14. Oil gutter          | 15. Breather             |
| 16. Dowel pin                | 17. Magnet              | 18. Baffle plate         |
| 19. Adapter plate            | 20. Baffle plate        | 21. Bearing retainer     |

# TRANSMISSION ASSEMBLY

SEC.321

**A**

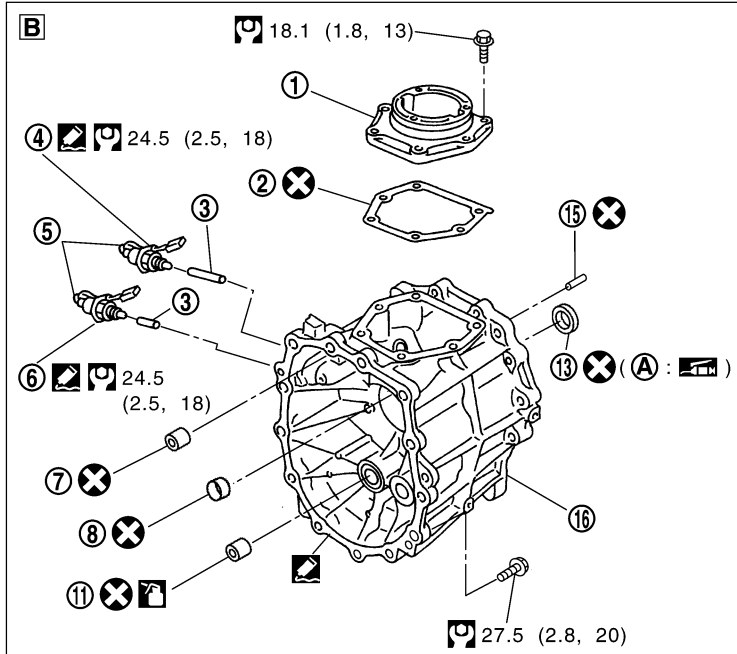
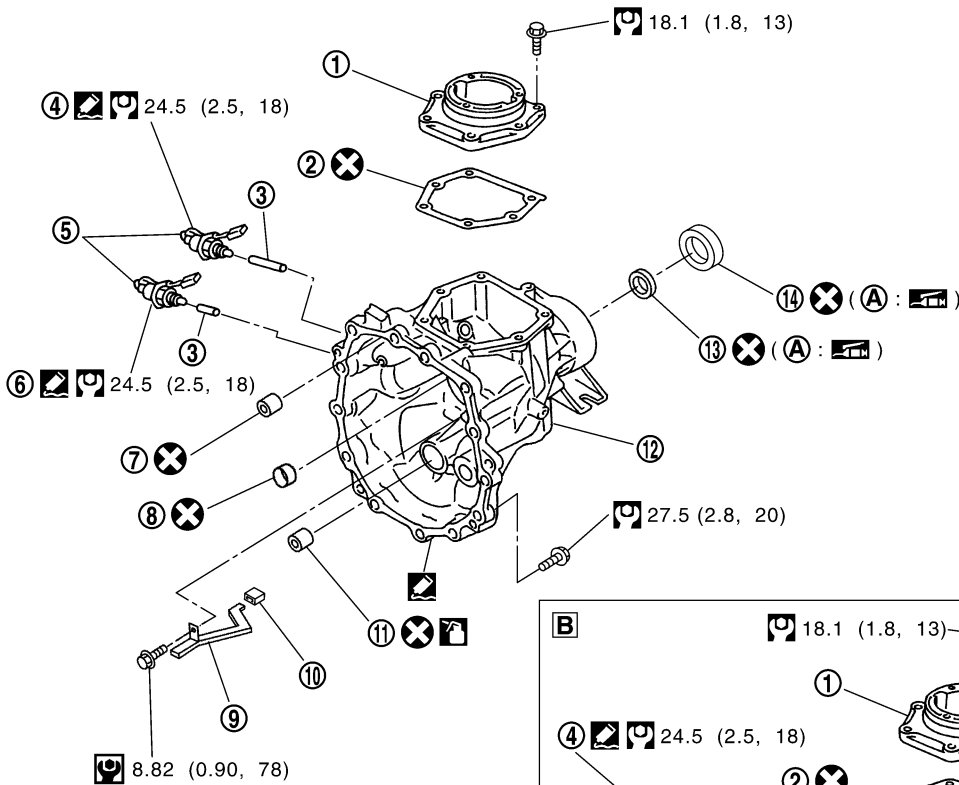

PCIB1656E

- |                                       |                         |                              |
|---------------------------------------|-------------------------|------------------------------|
| 1. Control housing                    | 2. Gasket               | 3. Plunger                   |
| 4. Park/neutral position (PNP) switch | 5. Clip                 | 6. Back-up lamp switch       |
| 7. Sliding ball bearing               | 8. Bushing              | 9. Rear extension oil gutter |
| 10. Cap                               | 11. Counter end bearing | 12. Rear extension           |
| 13. Rear oil seal                     | 14. Dust seal           | 15. Dowel pin                |
| 16. OD gear case                      |                         |                              |

A: Seal lip

**A**: 2WD models

**B**: 4WD models

Refer to [GI-10. "Components"](#) and the followings for the symbols in the figure.

: Apply Genuine Liquid Gasket, Three Bond TB1215 or the equivalent.

: Apply gear oil.

: Apply multi-purpose grease.

# TRANSMISSION ASSEMBLY

## Gear Components

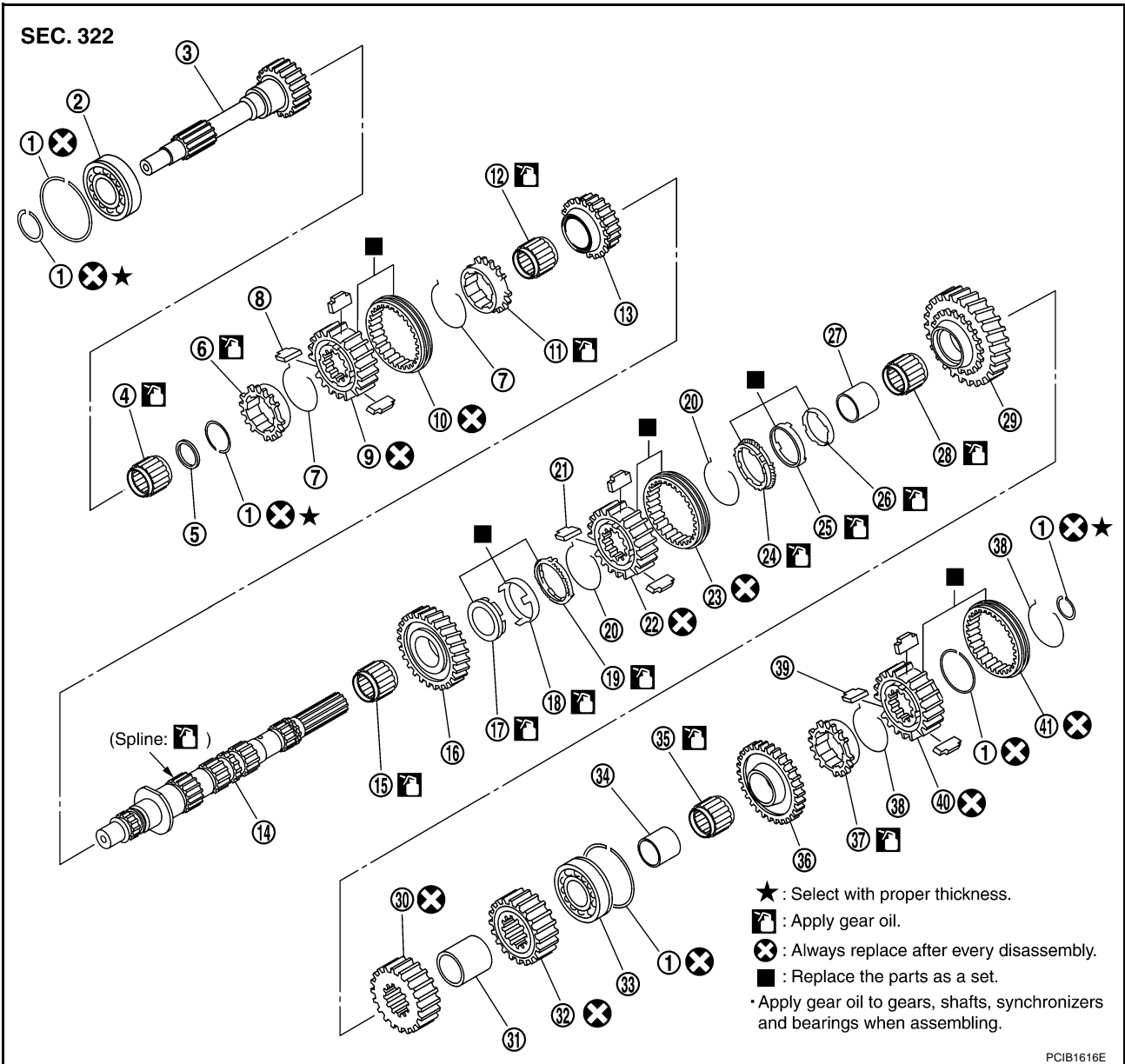

- |                               |                                 |                             |
|-------------------------------|---------------------------------|-----------------------------|
| 1. Snap ring                  | 2. Main drive gear bearing      | 3. Main drive gear          |
| 4. Main pilot bearing         | 5. Pilot bearing spacer         | 6. 5th baulk ring           |
| 7. 5th-6th spread spring      | 8. 5th-6th shifting insert      | 9. 5th-6th synchronizer hub |
| 10. 5th-6th coupling sleeve   | 11. 6th baulk ring              | 12. 6th needle bearing      |
| 13. 6th main gear             | 14. Mainshaft                   | 15. 2nd needle bearing      |
| 16. 2nd main gear             | 17. 2nd inner baulk ring        | 18. 2nd synchronizer cone   |
| 19. 2nd outer baulk ring      | 20. 1st-2nd spread spring       | 21. 1st-2nd shifting insert |
| 22. 1st-2nd synchronizer hub  | 23. 1st-2nd coupling sleeve     | 24. 1st outer baulk ring    |
| 25. 1st synchronizer cone     | 26. 1st inner baulk ring        | 27. 1st gear bushing        |
| 28. 1st needle bearing        | 29. 1st main gear               | 30. 3rd main gear           |
| 31. 3rd-4th main spacer       | 32. 4th main gear               | 33. Mainshaft bearing       |
| 34. Reverse main gear bushing | 35. Reverse main needle bearing | 36. Reverse main gear       |
| 37. Reverse baulk ring        | 38. Reverse spread spring       | 39. Reverse shifting insert |
| 40. Reverse synchronizer hub  | 41. Reverse coupling sleeve     |                             |

A  
B  
MT  
D  
E  
F  
G  
H  
I  
J  
K  
L  
M

# TRANSMISSION ASSEMBLY

SEC.322

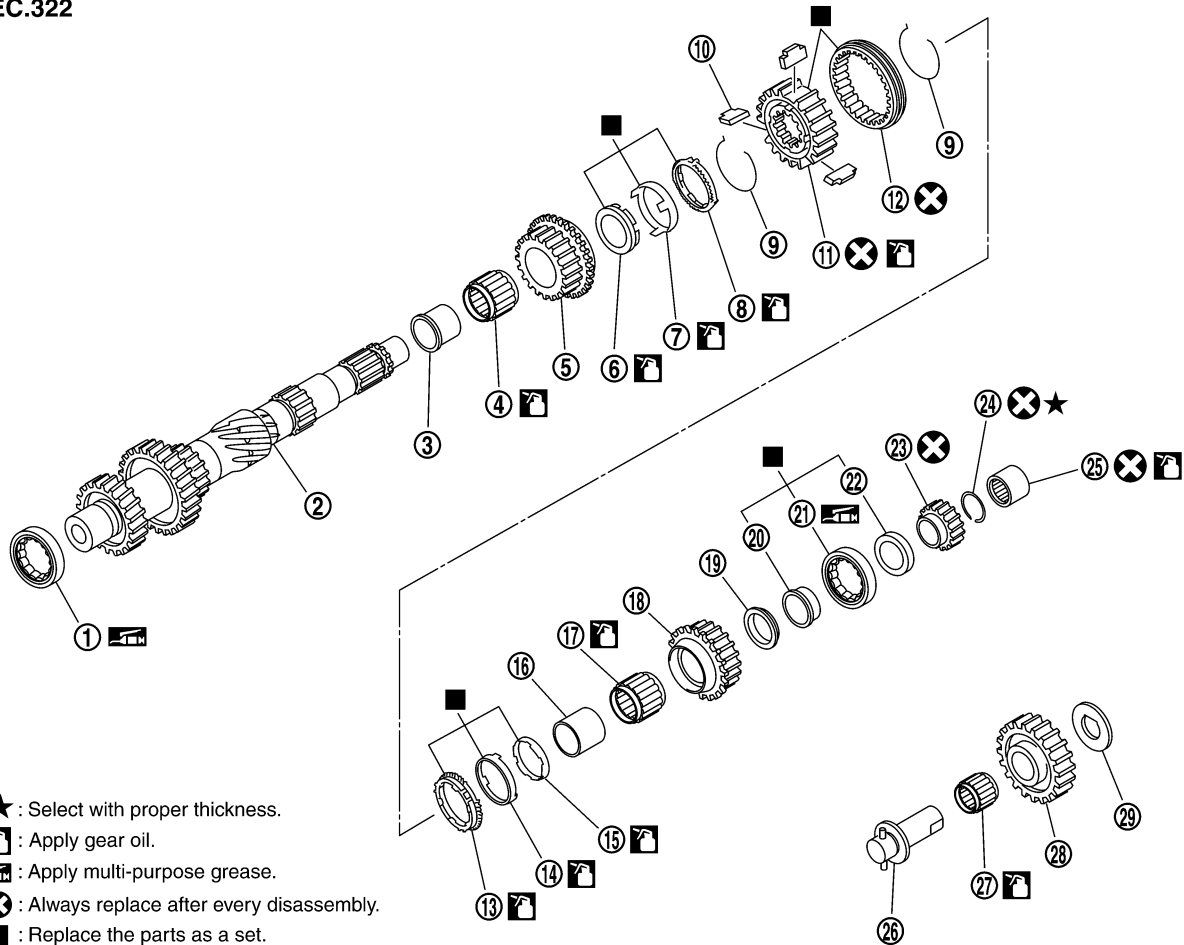

- ★ : Select with proper thickness.
- ⚙️ : Apply gear oil.
- 🧴 : Apply multi-purpose grease.
- ⊗ : Always replace after every disassembly.
- : Replace the parts as a set.

• Apply gear oil to gears, shafts, synchronizers and bearings when assembling.

PCIB1617E

- |                                    |                                     |                                  |
|------------------------------------|-------------------------------------|----------------------------------|
| 1. Counter front bearing           | 2. Counter gear                     | 3. 3rd gear bushing              |
| 4. 3rd needle bearing              | 5. 3rd counter gear                 | 6. 3rd inner baulk ring          |
| 7. 3rd synchronizer cone           | 8. 3rd outer baulk ring             | 9. 3rd-4th spread spring         |
| 10. 3rd-4th shifting insert        | 11. 3rd-4th synchronizer hub        | 12. 3rd-4th coupling sleeve      |
| 13. 4th outer baulk ring           | 14. 4th synchronizer cone           | 15. 4th inner baulk ring         |
| 16. 4th gear bushing               | 17. 4th needle bearing              | 18. 4th counter gear             |
| 19. 4th counter gear thrust washer | 20. Counter rear bearing inner race | 21. Counter rear bearing         |
| 22. Counter rear bearing spacer    | 23. Reverse counter gear            | 24. Snap ring                    |
| 25. Counter end bearing            | 26. Reverse idler shaft             | 27. Reverse idler needle bearing |
| 28. Reverse idler gear             | 29. Reverse idler thrust washer     |                                  |



# TRANSMISSION ASSEMBLY

## Shift Control Components

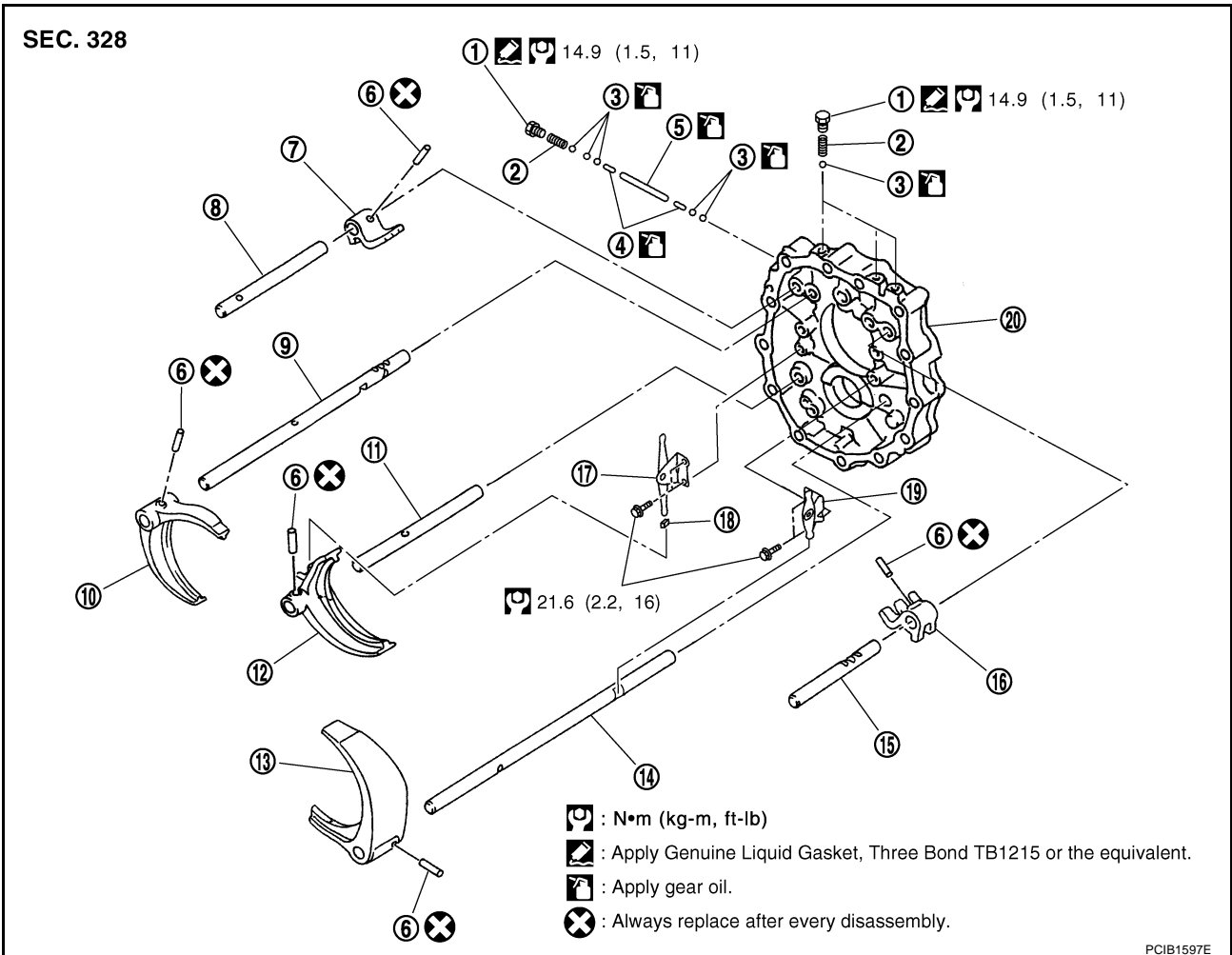

- |                              |                                      |                        |
|------------------------------|--------------------------------------|------------------------|
| 1. Check ball plug           | 2. Check ball spring                 | 3. Check ball          |
| 4. Interlock pin             | 5. Interlock plunger                 | 6. Retaining pin       |
| 7. 3rd-4th fork rod bracket  | 8. 3rd-4th fork rod                  | 9. 1st-2nd fork rod    |
| 10. 1st-2nd shift fork       | 11. 3rd-4th fork rod (reversal side) | 12. 3rd-4th shift fork |
| 13. 5th-6th shift fork       | 14. 5th-6th fork rod (reversal side) | 15. 5th-6th fork rod   |
| 16. 5th-6th fork rod bracket | 17. 3rd-4th control lever            | 18. Shifter cap        |
| 19. 5th-6th control lever    | 20. Adapter plate                    |                        |

A  
 B  
 MT  
 D  
 E  
 F  
 G  
 H  
 I  
 J  
 K  
 L  
 M

# TRANSMISSION ASSEMBLY

SEC.328

**A**

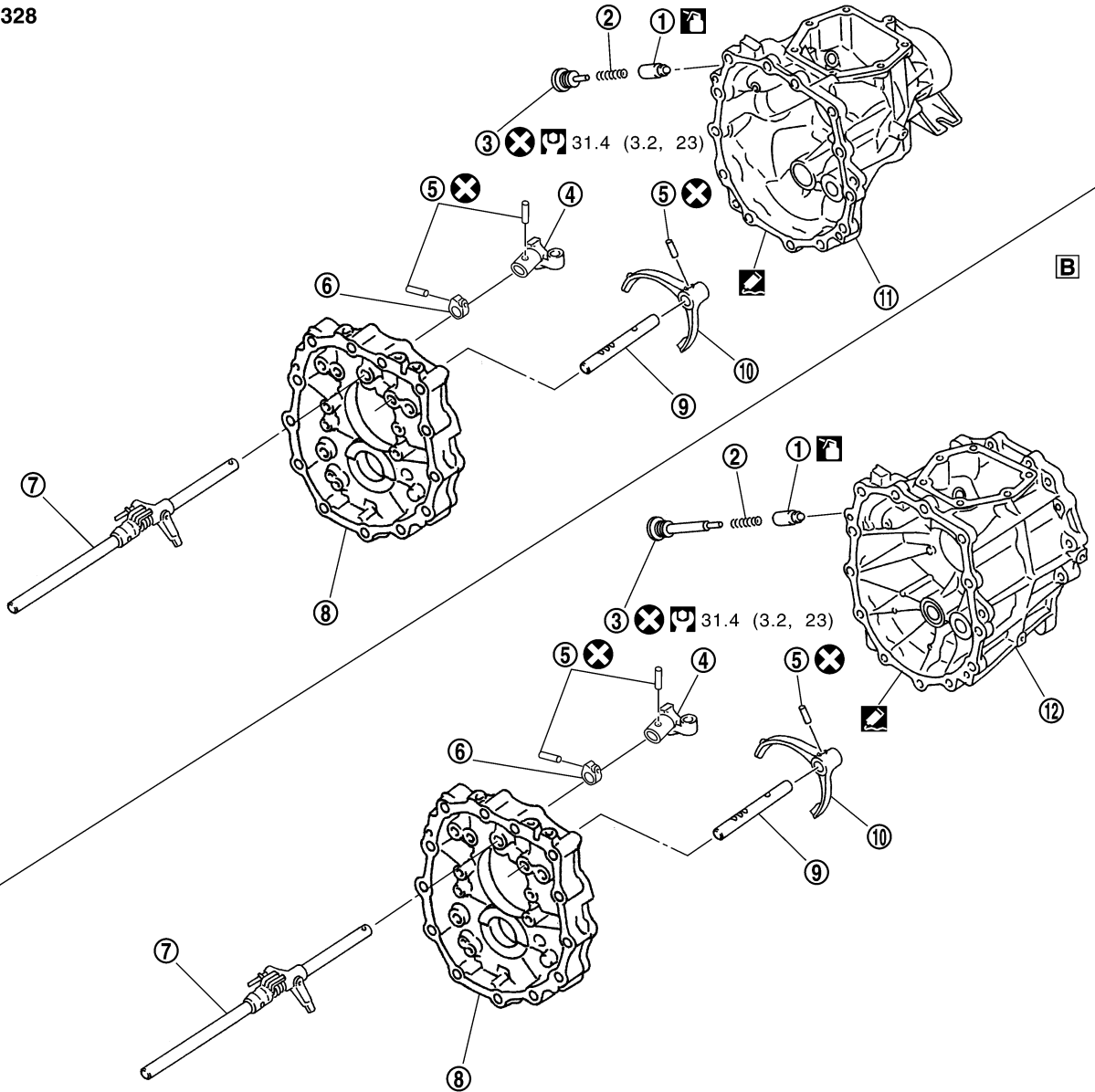

PCIB1657E

- |                          |                    |                       |
|--------------------------|--------------------|-----------------------|
| 1. Return spring plunger | 2. Return spring   | 3. Return spring plug |
| 4. Striking arm          | 5. Retaining pin   | 6. Stopper ring       |
| 7. Striking rod assembly | 8. Adapter plate   | 9. Reverse fork rod   |
| 10. Reverse shift fork   | 11. Rear extension | 12. OD gear case      |

**A**: 2WD models

**B**: 4WD models

Refer to [GI-10, "Components"](#) and the followings for the symbols in the figure.

: Apply Genuine Liquid Gasket, Three Bond TB1215 or the equivalent.

: Apply gear oil.

# TRANSMISSION ASSEMBLY

## DISASSEMBLY

### Case Components

1. Remove drain plug and gasket from transmission case.

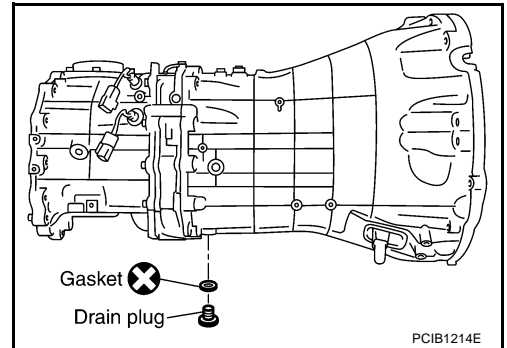

2. Remove clips from park/neutral position (PNP) switch and back-up lamp switch.
3. Remove park/neutral position (PNP) switch, back-up lamp switch and plungers from rear extension (or OD gear case).

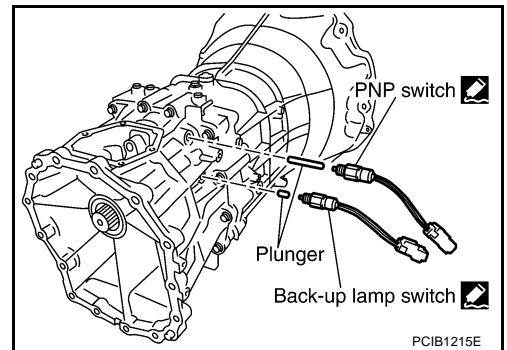

4. Remove control housing mounting bolts, and then remove control housing and gasket from rear extension (or OD gear case).

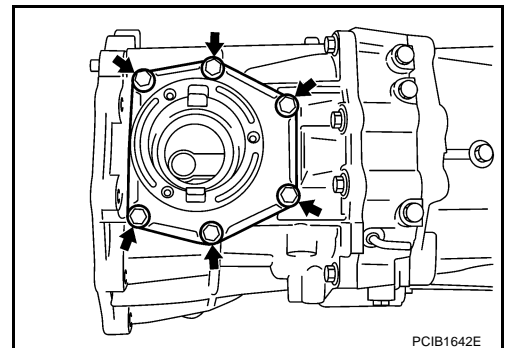

5. Remove return spring plug, return spring and return spring plunger from rear extension (or OD gear case).

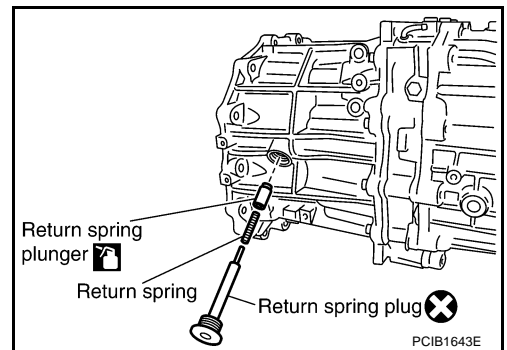

A  
B  
MT  
D  
E  
F  
G  
H  
I  
J  
K  
L  
M

# TRANSMISSION ASSEMBLY

6. Remove rear oil seal from OD gear case using the puller (for 4WD models).

**CAUTION:**

**Be careful not to damage OD gear case.**

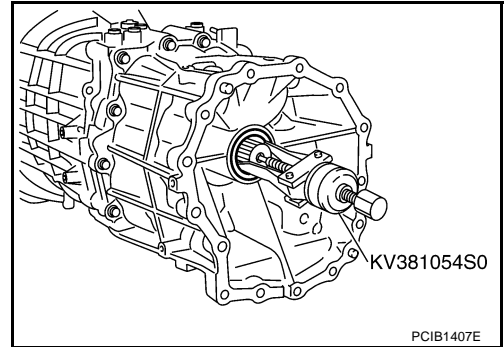

7. Remove retaining pin using a pin punch, and then remove striking arm from striking rod assembly.

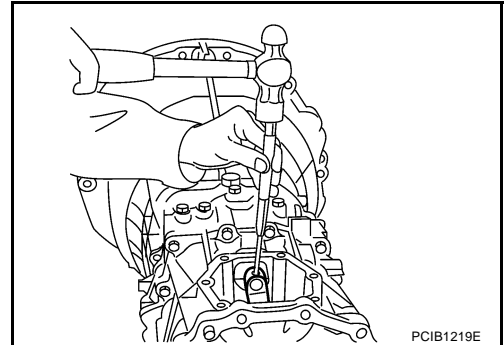

8. Remove rear extension (or OD gear case) mounting bolts, and then remove rear extension (or OD gear case) from adapter plate using a soft hammer.

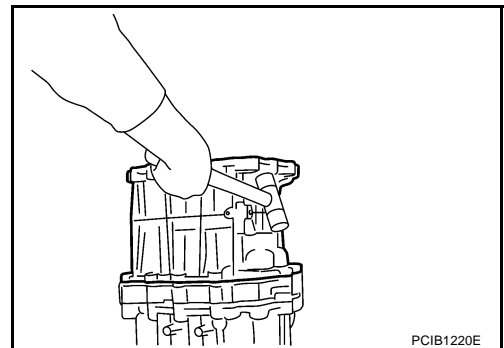

9. Remove rear extension oil gutter mounting bolt, and then remove rear extension oil gutter and cap from rear extension (for 2WD models).

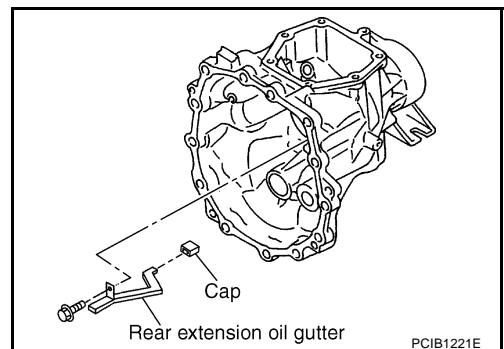

10. Remove dust seal and rear oil seal from rear extension using a flat-bladed screwdriver (for 2WD models).

**CAUTION:**

**Be careful not to damage rear extension.**

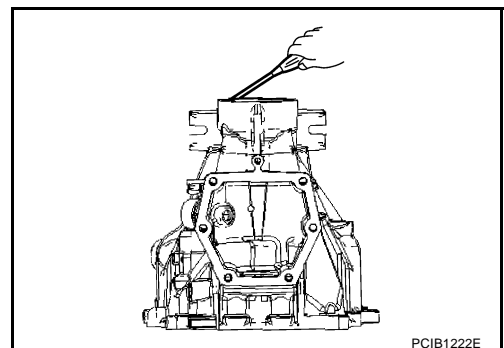

# TRANSMISSION ASSEMBLY

11. Remove counter end bearing from rear extension (or OD gear case) using a puller.

**CAUTION:**

Be careful not to damage rear extension (or OD gear case).

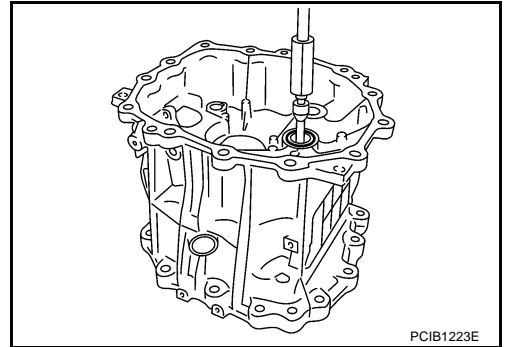

12. Remove withdrawal lever ball pin and washer from front cover.

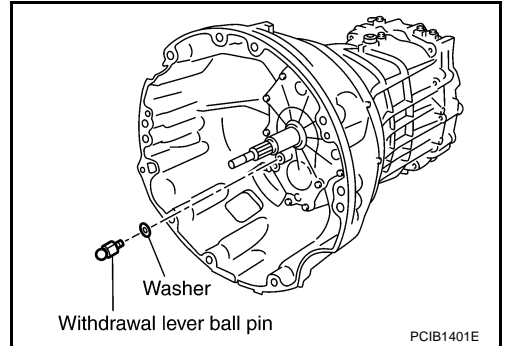

13. Remove front cover mounting bolts, and then remove front cover and front cover gasket from transmission case.

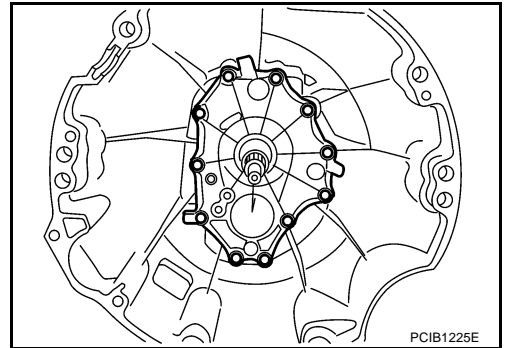

14. Remove front cover oil seal from front cover using a flat-bladed screwdriver.

**CAUTION:**

Be careful not to damage front cover.

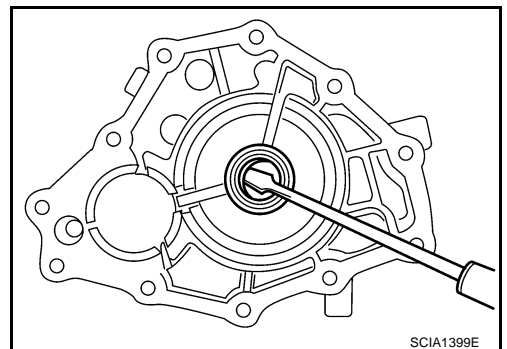

15. Remove baffle plate mounting nut from transmission case.

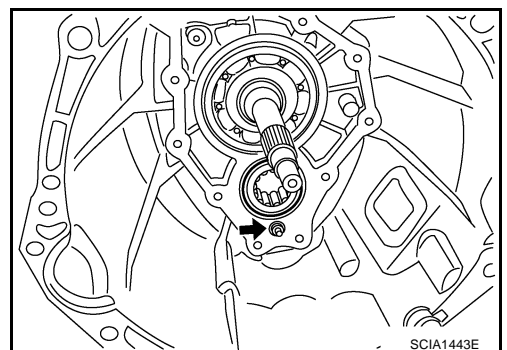

A

B

MT

D

E

F

G

H

I

J

K

L

M

# TRANSMISSION ASSEMBLY

16. Remove snap ring from main drive gear bearing using a snap ring pliers.

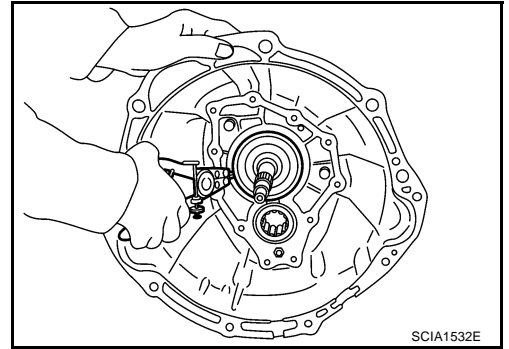

17. Remove pivot bolt and check shift pin from transmission case.

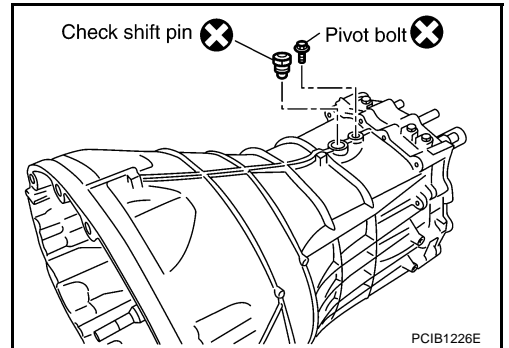

18. Remove transmission case from adapter plate.

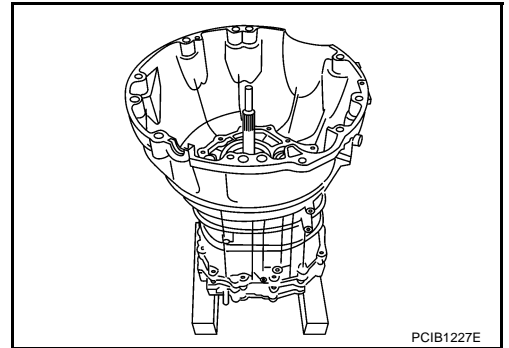

19. Remove counter front bearing from transmission case.

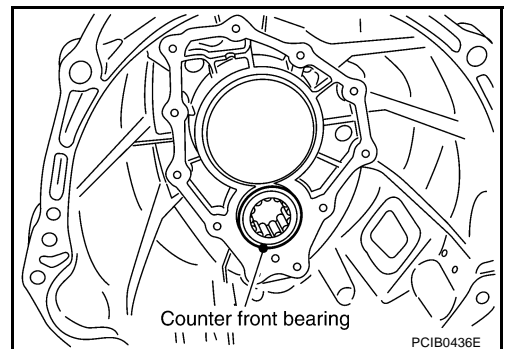

20. Remove oil gutter from transmission case.

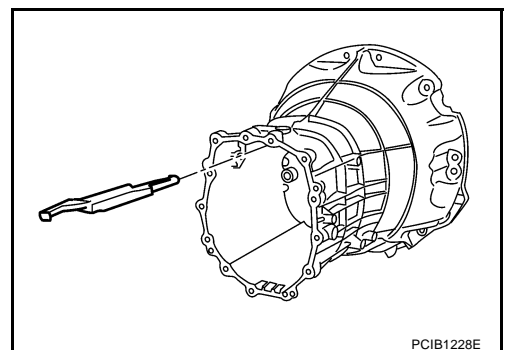

# TRANSMISSION ASSEMBLY

21. Remove filler plug and gasket from transmission case.

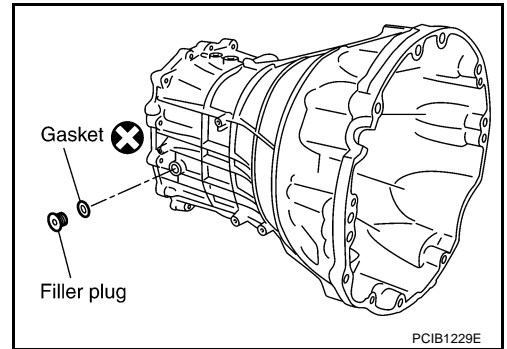

A  
B  
MT

## Shift Control Components

1. Remove rear extension (or OD gear case) and transmission case. Refer to [MT-27, "Case Components"](#).
2. Install adapter setting plate to adapter plate, and then fixing in adapter setting plate using a vise.

**CAUTION:**

**Do not directly secure mating surface of adapter plate in a vise.**

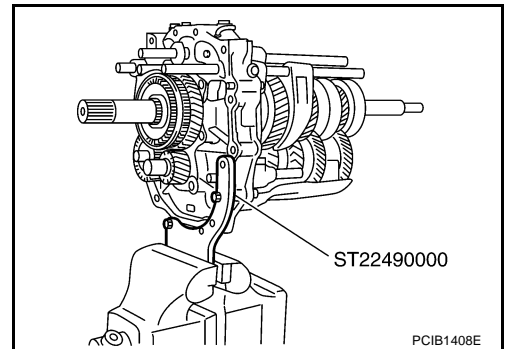

D  
E  
F  
G  
H

3. Remove baffle plate mounting bolts, and then remove baffle plate from adapter plate.

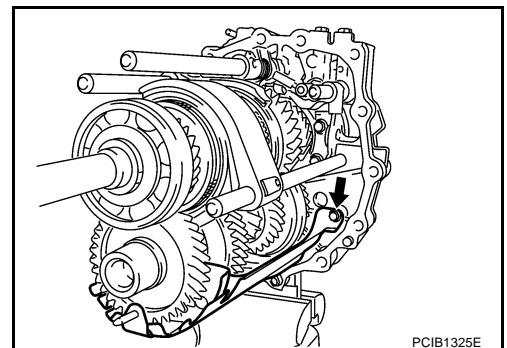

I  
J  
K  
L

4. Remove check ball plugs, check ball springs and check balls from adapter plate.

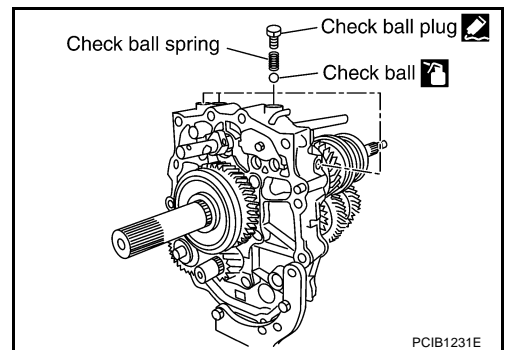

M

# TRANSMISSION ASSEMBLY

5. Remove 3rd-4th control lever mounting bolts, and then remove 3rd-4th control lever and shifter cap from adapter plate.

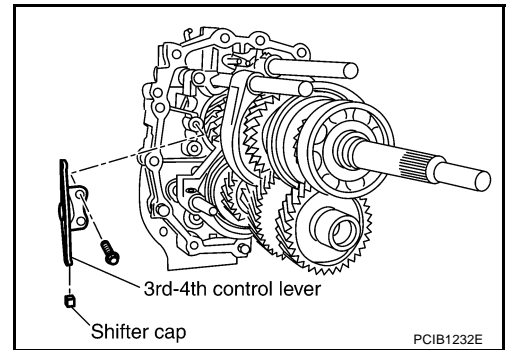

6. Remove retaining pin using a pin punch, and then remove 3rd - 4th fork rod bracket and 3rd-4th fork rod from adapter plate.

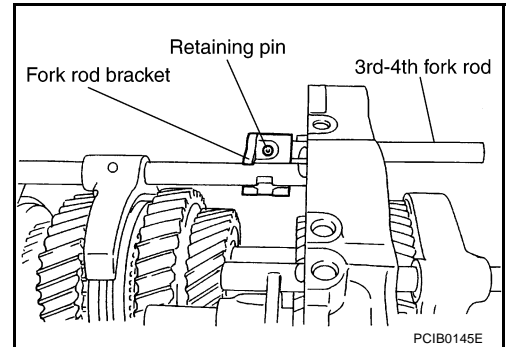

7. Remove check balls and interlock pin from adapter plate.

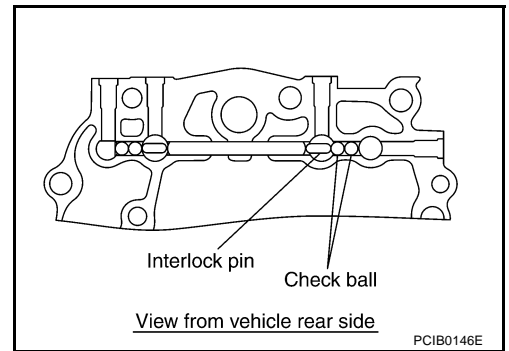

8. Remove retaining pin using a pin punch, and then remove 3rd-4th shift fork and 3rd-4th fork rod (reversal side) from adapter plate.

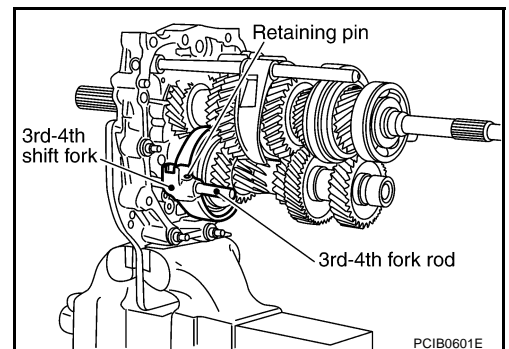

9. Remove retaining pin using a pin punch, and then remove 1st-2nd shift fork and 1st-2nd fork rod from adapter plate.

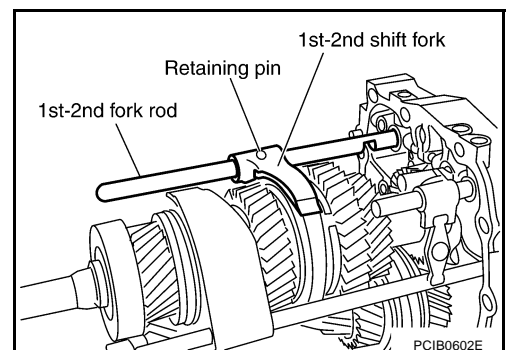



# TRANSMISSION ASSEMBLY

10. Remove interlock plunger and interlock pin from adapter plate.

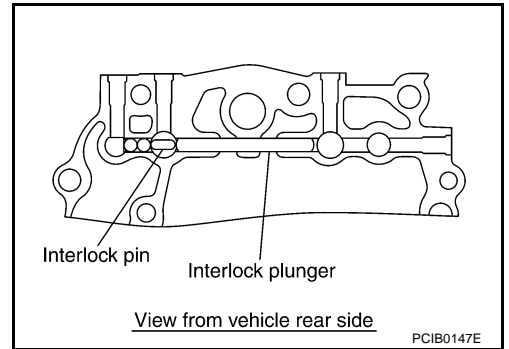

11. Remove retaining pin using a pin punch, and then remove reverse shift fork and reverse fork rod from adapter plate.

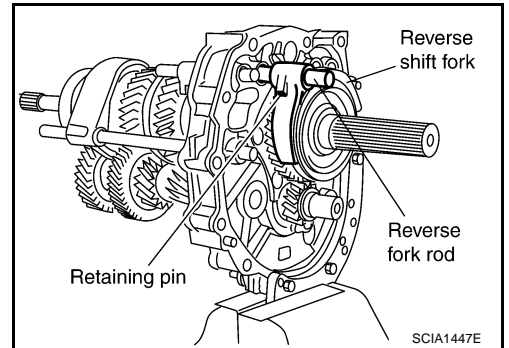

12. Remove check balls from adapter plate.

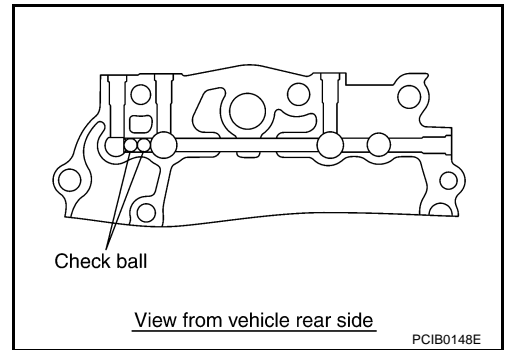

13. Remove retaining pin using a pin punch, and then remove 5th-6th fork rod bracket and 5th-6th fork rod from adapter plate.

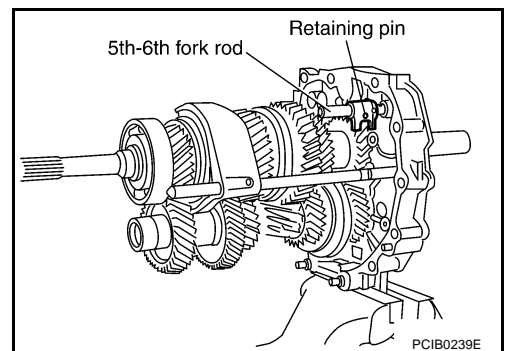

14. Remove 5th-6th control lever mounting bolts, and then remove 5th-6th control lever from adapter plate.

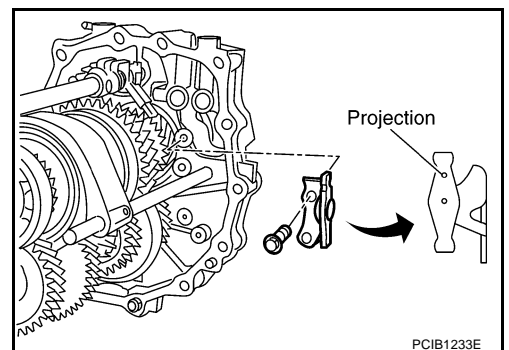

A  
B  
MT  
D  
E  
F  
G  
H  
I  
J  
K  
L  
M

# TRANSMISSION ASSEMBLY

15. Remove retaining pin using a pin punch, and then remove 5th-6th shift fork and 5th-6th fork rod (reversal side) from adapter plate.

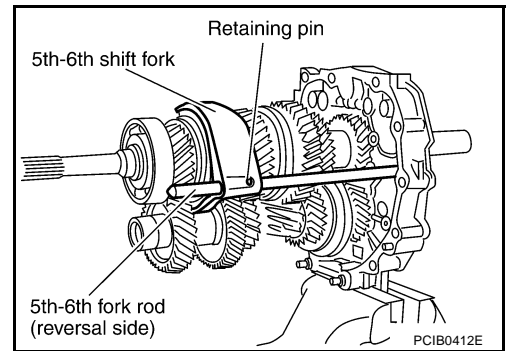

16. Remove retaining pin using pin punch, and then remove stopper ring from striking rod assembly.

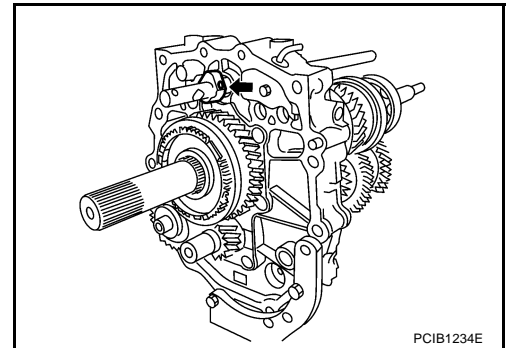

17. Remove striking rod assembly from adapter plate.

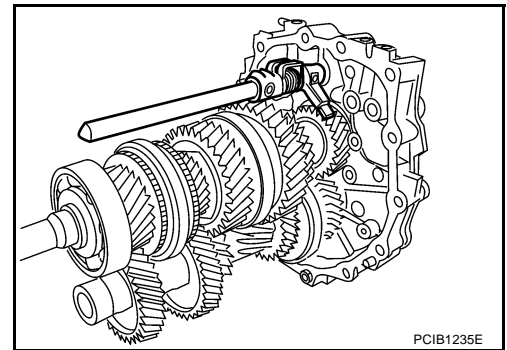

## Gear Components

1. Remove rear extension (or OD gear case) and transmission case. Refer to [MT-27, "Case Components"](#).
2. Remove shift forks and fork rods. Refer to [MT-31, "Shift Control Components"](#).
3. Before disassembling, measure the end play for each position. If the end play is outside the standards, disassemble and inspect.
  - Main drive gear

**End play:** 0 - 0.10 mm (0 - 0.004 in)

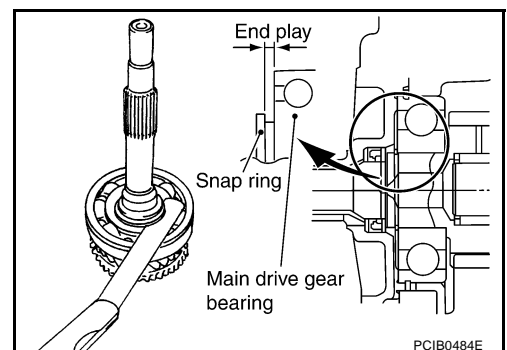

# TRANSMISSION ASSEMBLY

- Mainshaft (Rear side)

**End play:** 0 - 0.10 mm (0 - 0.004 in)

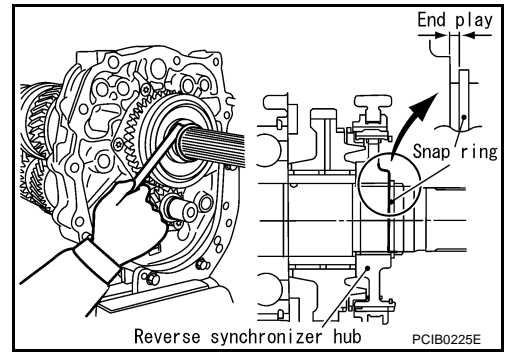

- Counter gear

**End play:** 0 - 0.10 mm (0 - 0.004 in)

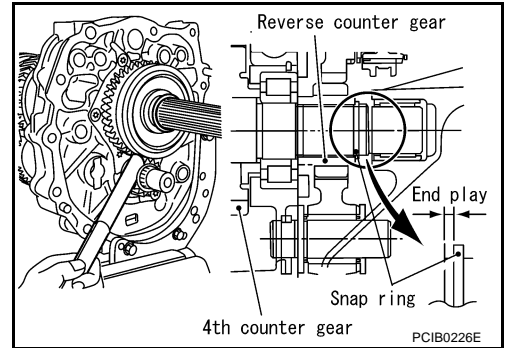

4. Remove reverse idler gear according to the following.
  - a. Remove reverse idler shaft assembly from adapter plate.
  - b. Remove reverse idler thrust washer, reverse idler gear and reverse idler needle bearing from reverse idler shaft.

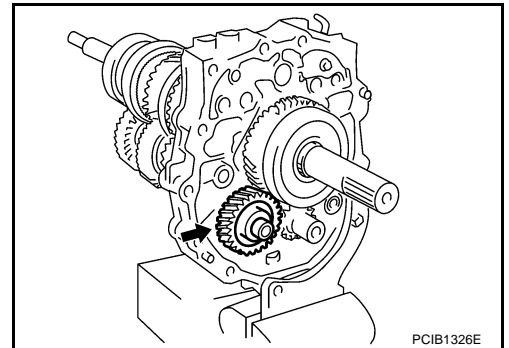

5. Remove reverse main gear and reverse synchronizer hub assembly according to the following.
  - a. Remove snap ring from mainshaft using a snap ring pliers.

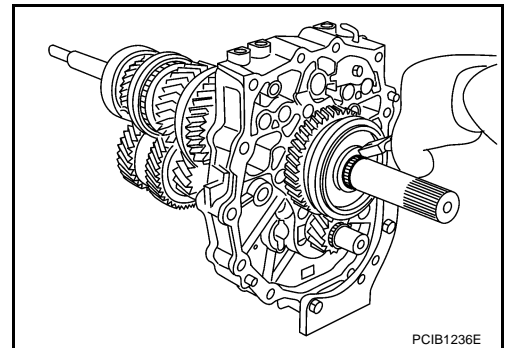

A  
B  
MT  
D  
E  
F  
G  
H  
I  
J  
K  
L  
M

# TRANSMISSION ASSEMBLY

- b. Remove reverse main gear and reverse synchronizer hub assembly using a puller.
- c. Remove reverse main needle bearing from mainshaft.

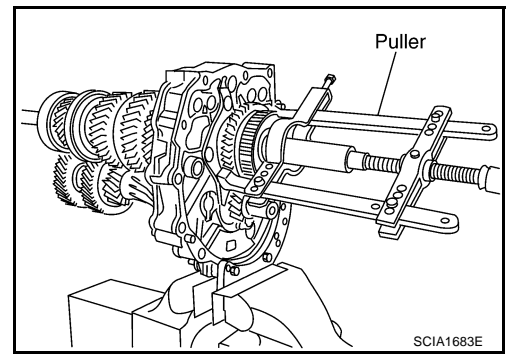

- 6. Remove reverse coupling sleeve according to the following.
  - a. Remove snap ring from reverse synchronizer hub.
  - b. Remove spread springs and shifting inserts from reverse synchronizer hub.
  - c. Remove reverse coupling sleeve from reverse synchronizer hub.

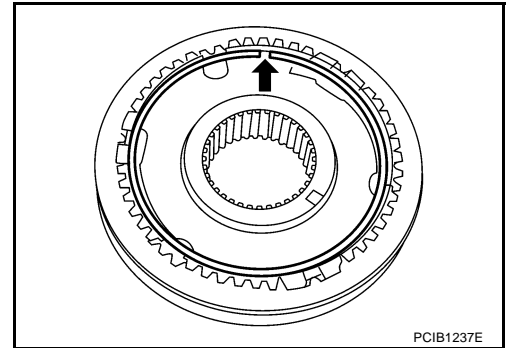

- 7. Remove reverse counter gear according to the following.
  - a. Remove snap ring from counter gear using a snap ring pliers.

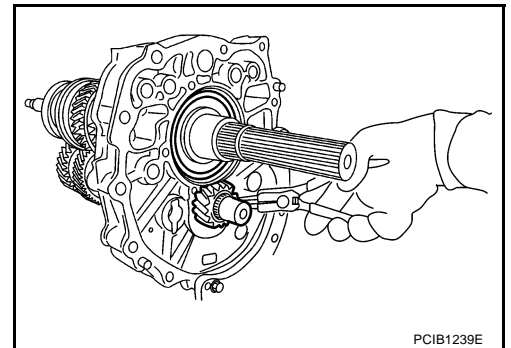

- b. Remove reverse counter gear using a puller.
- 8. Remove counter rear bearing spacer from counter gear.

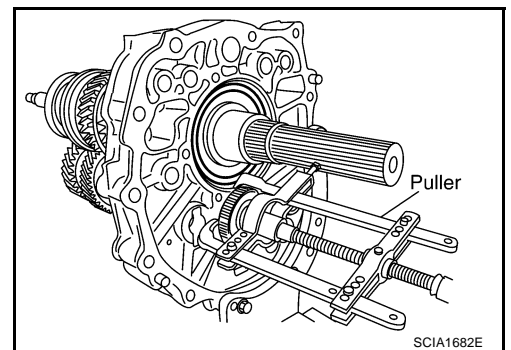

# TRANSMISSION ASSEMBLY

9. Remove bearing retainer mounting bolts, and then remove bearing retainer.

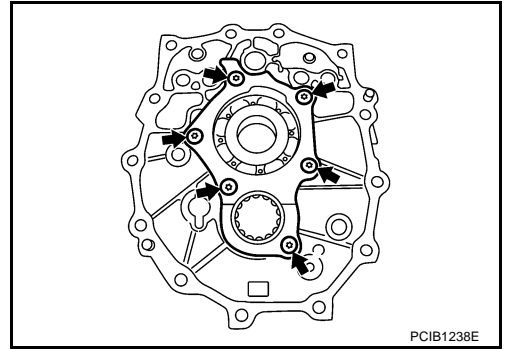

10. Remove main drive gear assembly, mainshaft assembly and counter gear assembly according to the following.

- a. Remove snap ring from mainshaft bearing using a snap ring pliers.

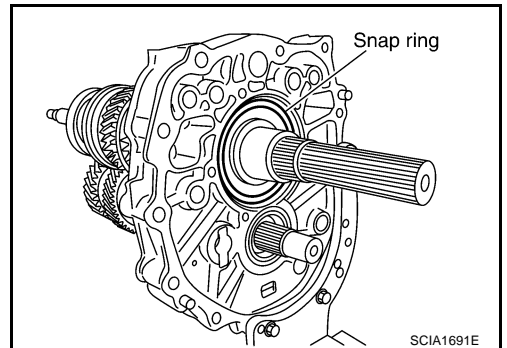

- b. Carefully tap mainshaft with a plastic hammer, and then remove main drive gear assembly, mainshaft assembly and counter gear assembly from adapter plate.
- c. Remove main pilot bearing and pilot bearing spacer from mainshaft.
- d. Remove 5th baulk ring from main drive gear.

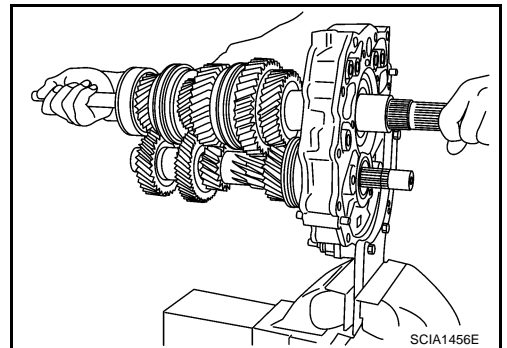

11. Remove counter rear bearing from adapter plate.

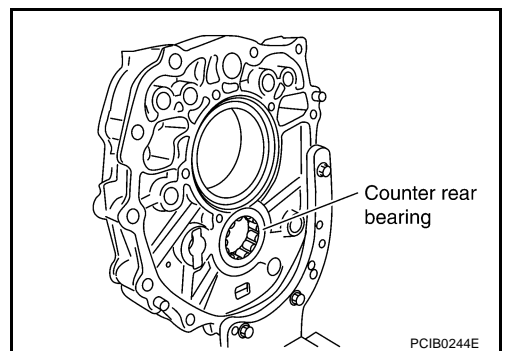

A  
B  
MT  
D  
E  
F  
G  
H  
I  
J  
K  
L  
M

# TRANSMISSION ASSEMBLY

12. Remove magnet from adapter plate.

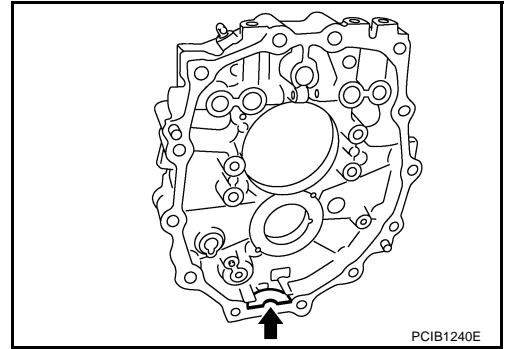

13. Remove baffle plate mounting bolt, and then remove baffle plate from adapter plate.

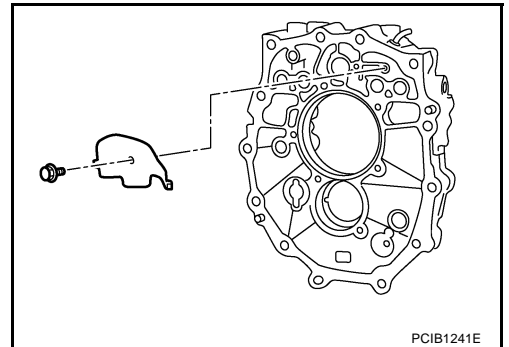

14. Remove breather from adapter plate.

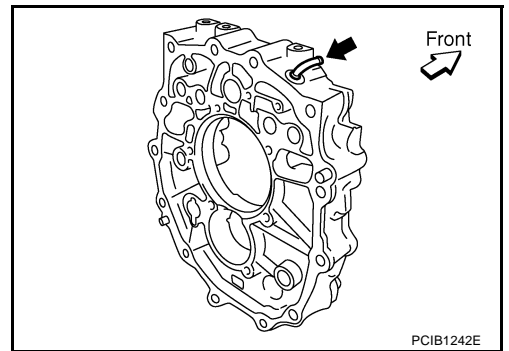

15. Remove main drive gear bearing according to the following.

a. Remove snap ring from main drive gear using a snap ring pliers.

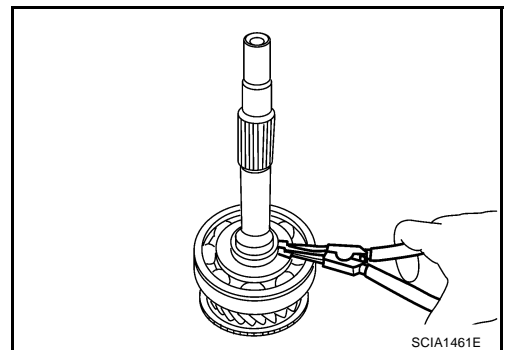

# TRANSMISSION ASSEMBLY

- b. Press out main drive gear bearing using a puller.

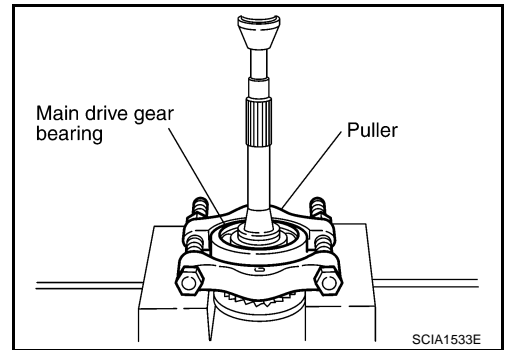

16. Before disassembling, measure the end play for mainshaft (Front side). If the end play is outside the standards, disassemble and inspect.

**End play:**            **0 - 0.10 mm (0 - 0.004 in)**

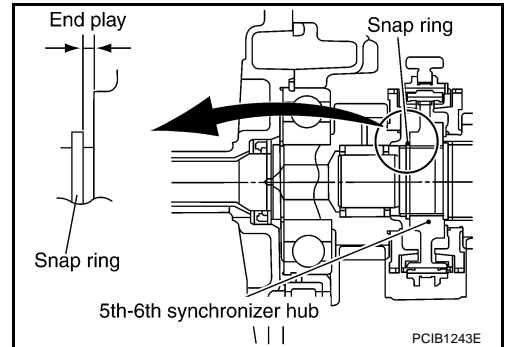

17. Press out reverse main gear bushing, mainshaft bearing and 4th main gear using a puller.  
18. Remove 3rd-4th main spacer from mainshaft.

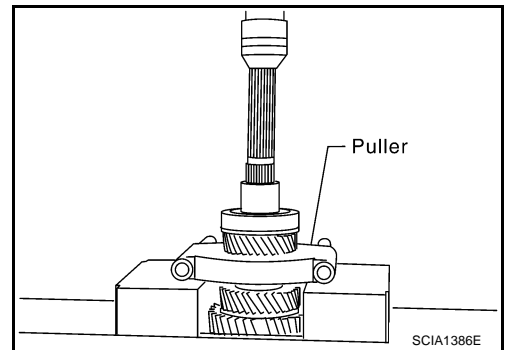

19. Remove 3rd main gear and 1st main gear according to the following.  
a. Press out 3rd main gear and 1st main gear using a puller.  
**CAUTION:**  
**Be careful not to damage 1st outer baulk ring.**  
b. Remove 1st needle bearing from mainshaft.

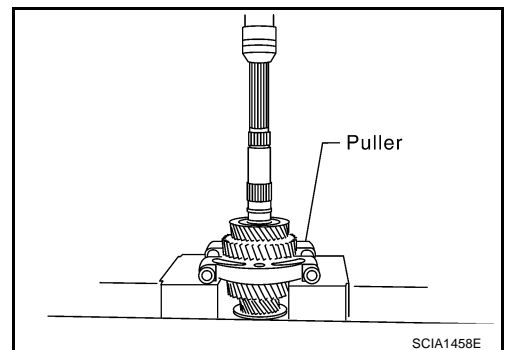

20. Remove 1st-2nd synchronizer hub assembly and 2nd main gear according to the following.

A  
B  
MT  
D  
E  
F  
G  
H  
I  
J  
K  
L  
M

# TRANSMISSION ASSEMBLY

- a. Press out 1st gear bushing, 1st-2nd synchronizer hub assembly and 2nd main gear using a puller.

**CAUTION:**

**Be aware that when using the press, if mainshaft gear positioner catches on the V-block, etc., mainshaft could be damaged.**

- b. Remove 2nd needle bearing from mainshaft.
21. Remove 1st-2nd coupling sleeve according to the following.
  - a. Remove spread springs and shifting inserts from 1st-2nd synchronizer hub.
  - b. Remove 1st-2nd coupling sleeve from 1st-2nd synchronizer hub.

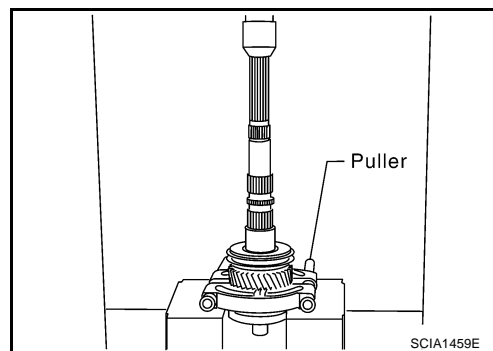

22. Remove 6th main gear and 5th-6th synchronizer hub assembly according to the following.
  - a. Remove snap ring from mainshaft using a snap ring pliers.

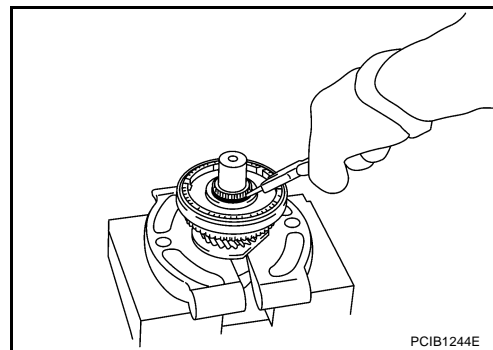

- b. Press out 6th main gear and 5th-6th synchronizer hub assembly using a puller.
- c. Remove 6th needle bearing from mainshaft.
23. Remove 5th-6th coupling sleeve according to the following.
  - a. Remove spread springs and shifting inserts from 5th-6th synchronizer hub.
  - b. Remove 5th-6th coupling sleeve from 5th-6th synchronizer hub.

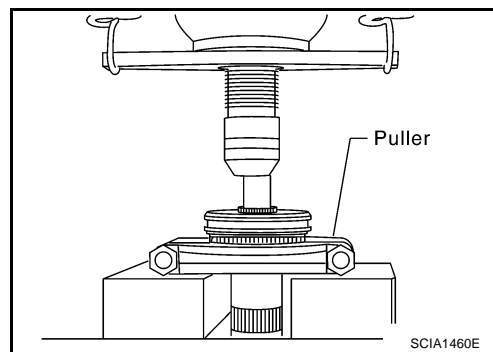

24. Remove 3rd counter gear, 3rd-4th synchronizer hub assembly and 4th counter gear according to the following.

- a. Press out 3rd counter gear, 3rd-4th synchronizer hub assembly, 4th counter gear, 4th needle bearing, 4th gear bushing, 4th counter gear thrust washer and counter rear bearing inner race using a puller.
- b. Remove 3rd needle bearing from counter gear.
25. Remove 3rd-4th coupling sleeve according to the following.
  - a. Remove spread springs and shifting inserts from 3rd-4th synchronizer hub.
  - b. Remove 3rd-4th coupling sleeve from 3rd-4th synchronizer hub.

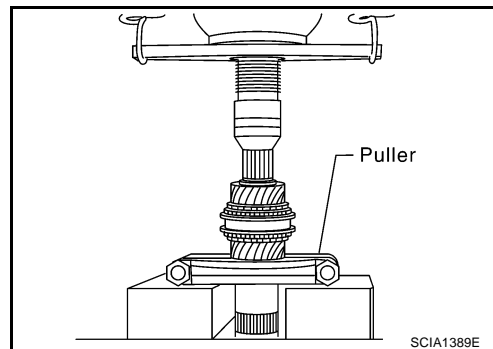



# TRANSMISSION ASSEMBLY

26. Press out 3rd gear bushing using a puller.

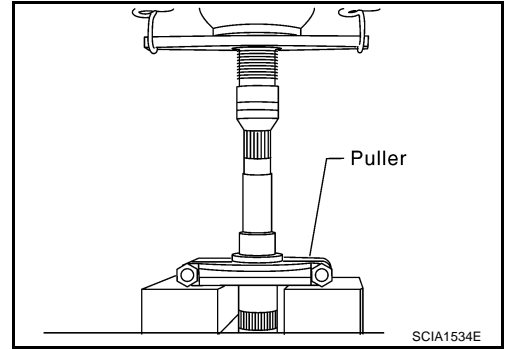

A

B

MT

D

E

F

G

H

I

J

K

L

M

# TRANSMISSION ASSEMBLY

## INSPECTION AFTER DISASSEMBLY

### Shift Control

If the contact surface on striking lever, fork rod, shift fork, etc., has excessive wear, abrasion, bend, or any other damage, replace the components.

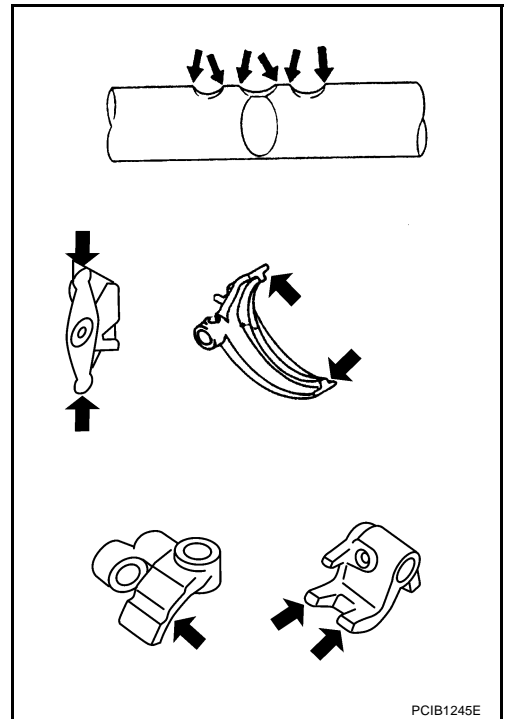

### Gear and Shaft

If the contact surface on each gear, mainshaft, main drive gear, and counter gear, etc., has damage, peeling, abrasion, dent, bent, or any other damage, replace the components.

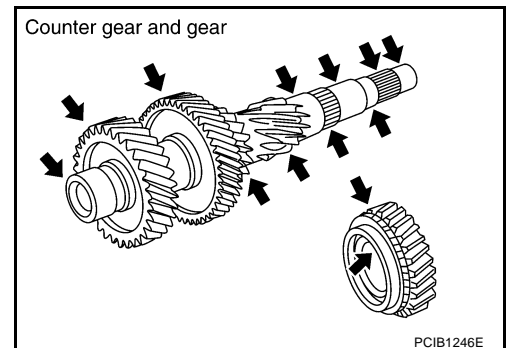
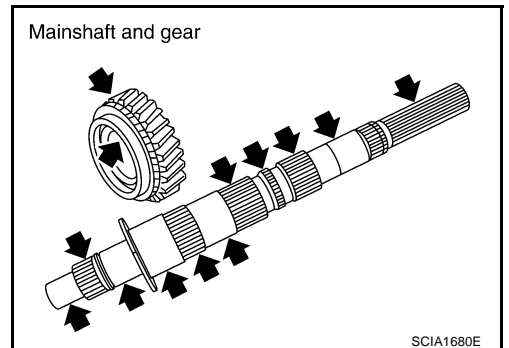

# TRANSMISSION ASSEMBLY

## Synchronizer

- If the contact surface on coupling sleeve, synchronizer hub, and shifting insert has damage or abrasion, replace the components.
- Coupling sleeve and synchronizer hub shall move smoothly.

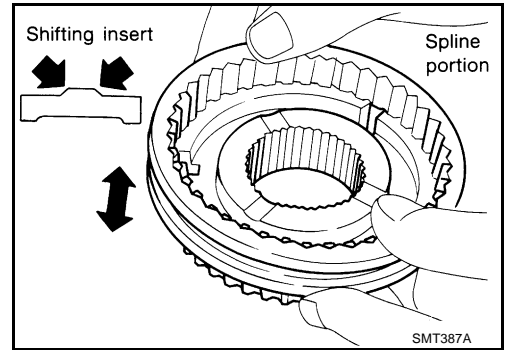

- If the cam surface on baulk ring or contact surface on insert has damage or excessive wear, replace with a new one.
- If spread spring damaged, replace with a new one.

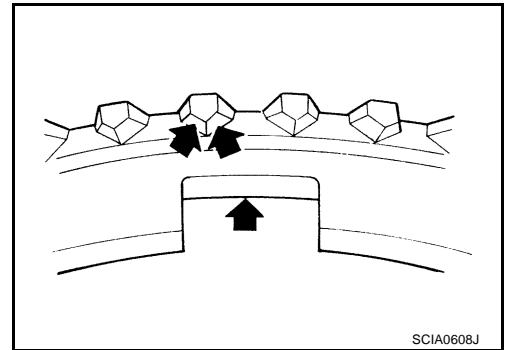

## Baulk Ring Clearance

- **Single Cone Synchronizer (5th and 6th)**  
Push baulk ring on the cone, and measure the clearance between baulk ring and cone. If the measurement is below limit, replace it with a new one.

### Clearance

**Standard value:** 0.7 - 1.35 mm (0.028 - 0.0531 in)

**Limit value:** 0.5 mm (0.020 in)

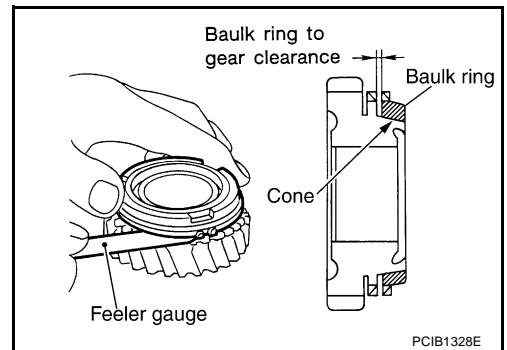

- **Double Cone Synchronizer (1st, 3rd and 4th)**  
Check the clearance between outer baulk ring, synchronizer cone and inner baulk ring as follows.

### CAUTION:

The clearances "A" and "B" are controlled with outer baulk ring, synchronizer cone and inner baulk ring as a set. Replace them as a set if the clearances are outside the limit value.

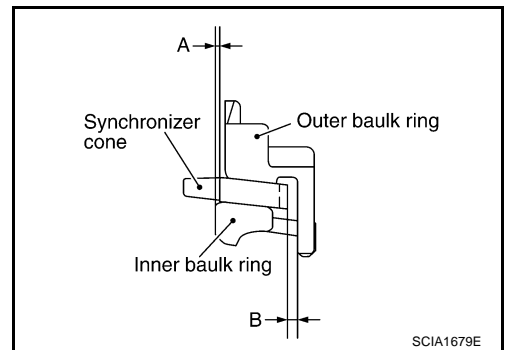

# TRANSMISSION ASSEMBLY

1. Measure the clearance "A" at 2 points or more diagonally opposite using a dial indicator. And then calculate mean value.

### Clearance "A"

**Standard value:** 0.5 - 0.7 mm (0.020 - 0.028 in)

**Limit value:** 0.3 mm (0.012 in)

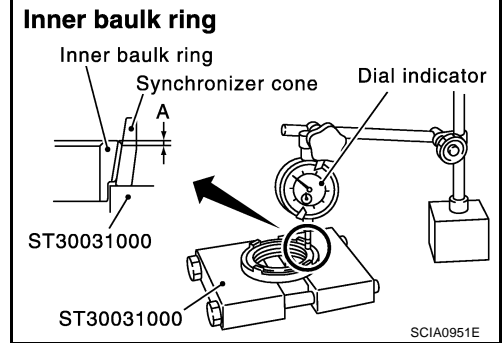

2. Measure the clearance "B" at 2 points or more diagonally opposite using a feeler gauge. And then calculate mean value.

### Clearance "B"

**Standard value**

**1st:** 1.0 - 1.5 mm (0.039 - 0.059 in)

**3rd, 4th:** 0.85 - 1.35 mm (0.0335 - 0.0531 in)

**Limit value:** 0.7 mm (0.028 in)

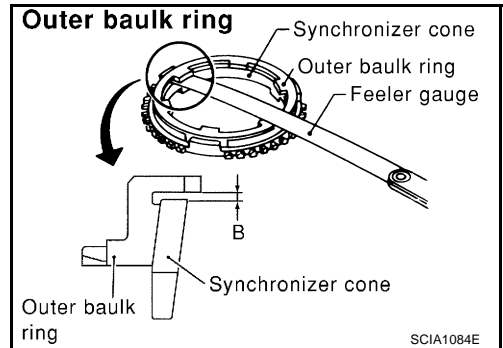

- **Triple Cone Synchronizer (2nd)**

Check the clearance between outer baulk ring, synchronizer cone and inner baulk ring as follows.

### CAUTION:

The clearances "A", "B" and "C" are controlled with outer baulk ring, synchronizer cone and inner baulk ring as a set. Replace them as a set if the clearances are outside the limit value.

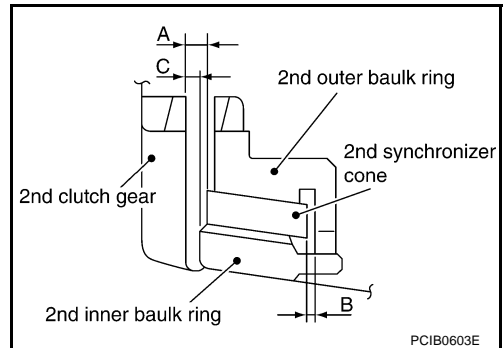

1. Measure the clearance "A" at 2 points or more diagonally opposite using a feeler gauge when pressing baulk ring toward clutch gear taper cone. And then calculate mean value.

### Clearance "A"

**Standard value:** 0.6 - 1.3 mm (0.024 - 0.051 in)

**Limit value:** 0.3 mm (0.012 in)

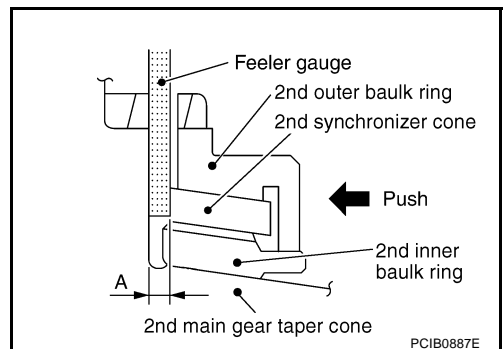

2. Measure the clearance "B" at 2 points or more diagonally opposite using a feeler gauge. And then calculate mean value.

### Clearance "B"

**Standard value:** 0.85 - 1.35 mm (0.0335 - 0.0531 in)

**Limit value:** 0.7 mm (0.028 in)

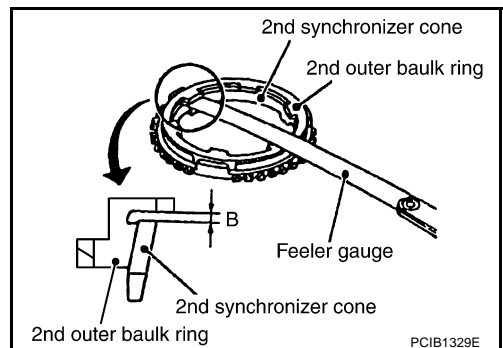

# TRANSMISSION ASSEMBLY

3. Measure the clearance "C" at 2 points or more diagonally opposite using a feeler gauge when pressing baulk ring toward clutch gear taper cone. And then calculate mean value.

## Clearance "C"

**Standard value:** 0.7 - 1.25 mm (0.028 - 0.0492 in)

**Limit value:** 0.3 mm (0.012 in)

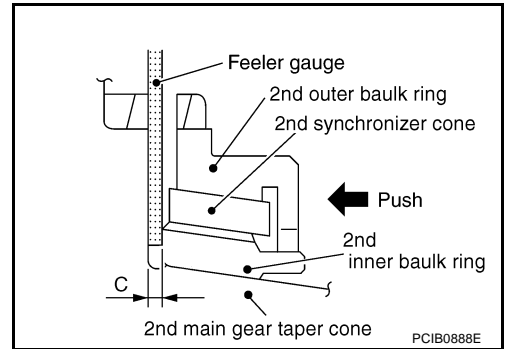

## Reverse Synchronizer

Push baulk ring on the cone, and measure the clearance between baulk ring and cone. If the measurement is below limit, replace it with a new one.

## Clearance

**Standard value:** 0.75 - 1.2 mm (0.0295 - 0.047 in)

**Limit value:** 0.5 mm (0.020 in)

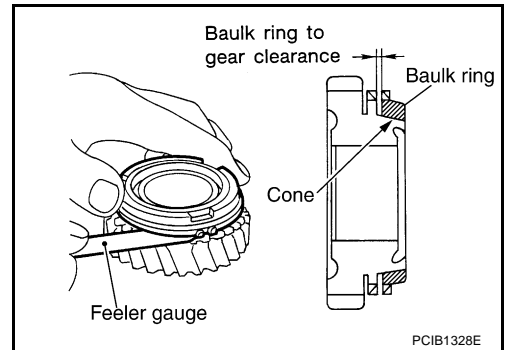

## Bearing

If the bearing does not rotate smoothly or the contact surface on ball or race is damaged or peeled, replace with new ones.

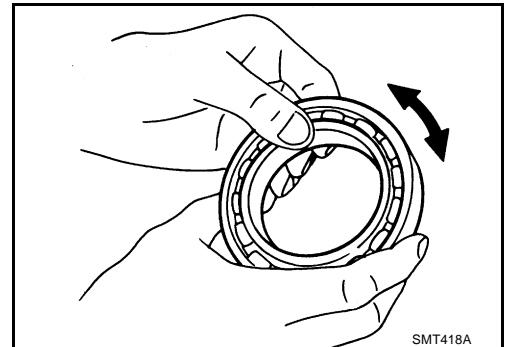

A  
B  
MT  
D  
E  
F  
G  
H  
I  
J  
K  
L  
M

# TRANSMISSION ASSEMBLY

## ASSEMBLY

### Gear Components

1. Install 5th-6th synchronizer hub assembly according to the following.
  - a. Install 5th-6th coupling sleeve to 5th-6th synchronizer hub.

**CAUTION:**

- Do not reuse 5th-6th synchronizer hub and 5th-6th coupling sleeve.
- Replace 5th-6th synchronizer hub and 5th-6th coupling sleeve as a set.
- Be careful with the orientation 5th-6th coupling sleeve.

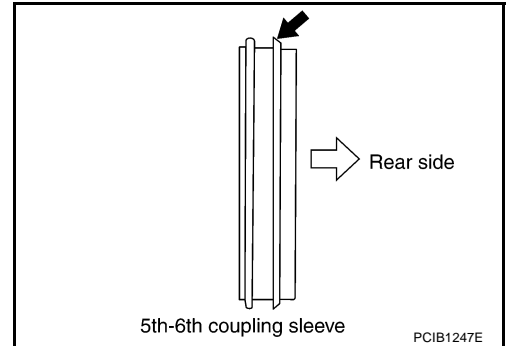

- Be careful with the orientation 5th-6th synchronizer hub.

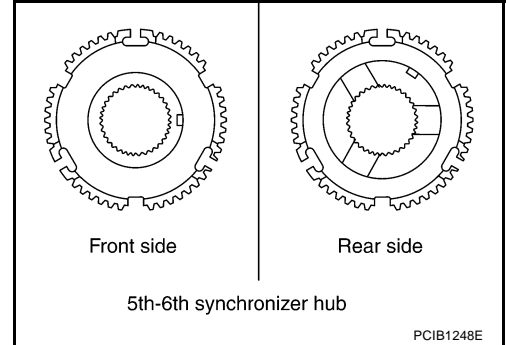

- b. Install shifting inserts and spread springs to 5th-6th synchronizer hub.

**CAUTION:**

- Do not install spread spring hook onto the same shifting insert.

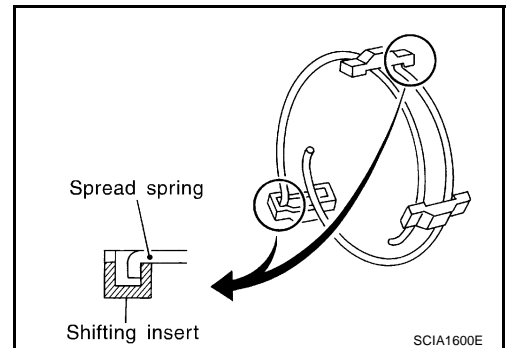

- Be careful with the shape of reserve shifting insert to avoid misemploy.

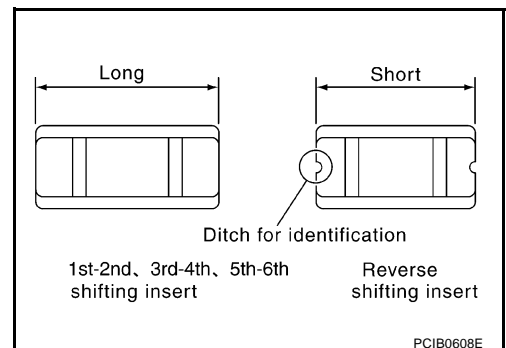

# TRANSMISSION ASSEMBLY

- c. Press in 5th-6th synchronizer hub assembly, 6th baulk ring, 6th main gear and 6th needle bearing using the inserter.

**CAUTION:**

- Apply gear oil to 6th baulk ring and 6th needle bearing.
- Be careful with the orientation 5th-6th coupling sleeve.

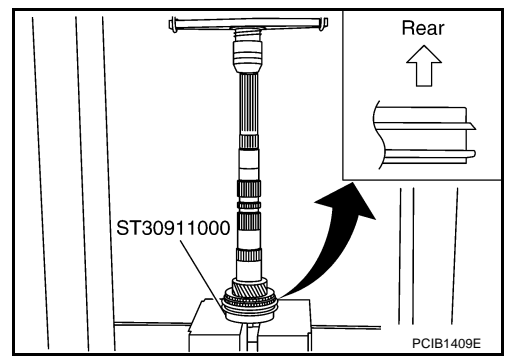

**NOTE:**

5th and 6th baulk rings have three spaces that four gear teeth are missing as shown in the figure.

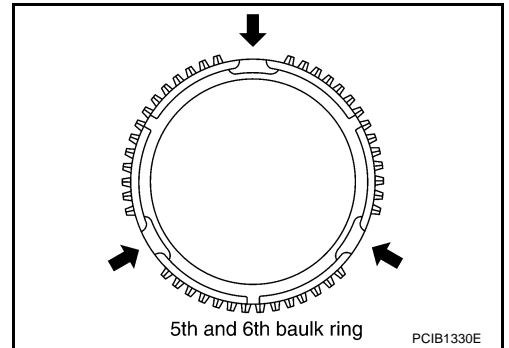

2. Select and install a snap ring so that the end play comes within the standard value. Refer to [MT-70, "Snap Rings"](#).

**End play:**            **0 - 0.10 mm (0 - 0.004 in)**

**CAUTION:**

**Do not reuse snap ring.**

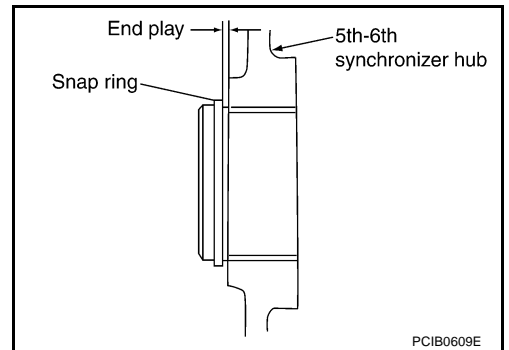

3. Install 1st-2nd synchronizer hub assembly according to the following.  
a. Install 1st-2nd coupling sleeve to 1st-2nd synchronizer hub.

**CAUTION:**

- Do not reuse 1st-2nd coupling sleeve and 1st-2nd synchronizer hub.
- Replace 1st-2nd synchronizer hub and 1st-2nd coupling sleeve as a set.
- Be careful with the orientation 1st-2nd coupling sleeve.

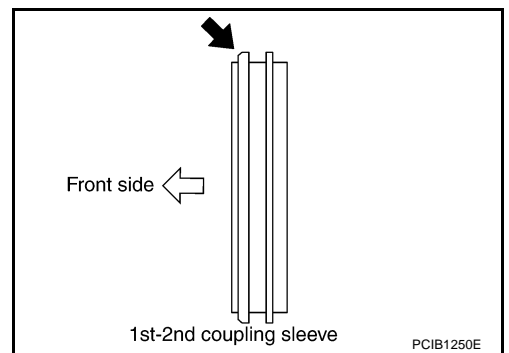

A  
B  
MT  
D  
E  
F  
G  
H  
I  
J  
K  
L  
M

# TRANSMISSION ASSEMBLY

- Be careful with the orientation 1st-2nd synchronizer hub.

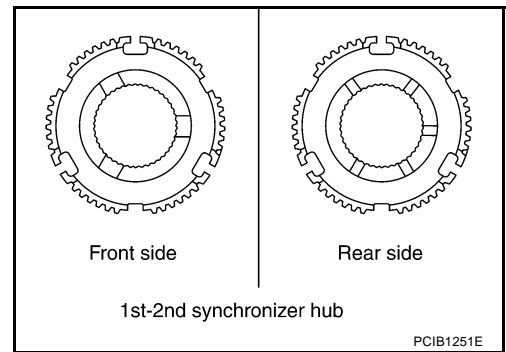

- b. Install spread springs and shifting inserts to 1st-2nd synchronizer hub.

**CAUTION:**

- Do not install spread spring hook onto the same shifting insert.

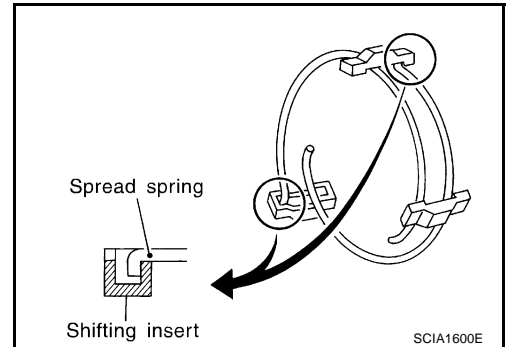

- Be careful with the shape of reverse shifting insert to avoid misassembly.

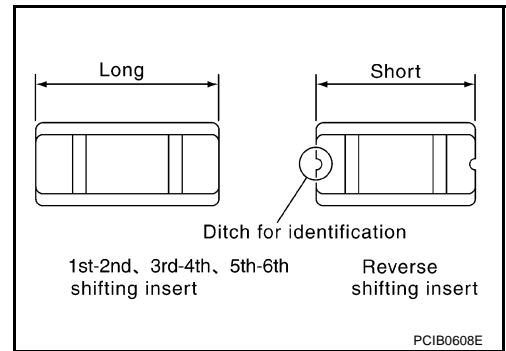

- c. Press in 1st-2nd synchronizer hub assembly, 2nd inner baulk ring, 2nd synchronizer cone, 2nd outer baulk ring, 2nd main gear and 2nd needle bearing using the support ring.

**CAUTION:**

- Apply gear oil to 2nd needle bearing, 2nd inner baulk ring, 2nd synchronizer cone, 2nd outer baulk ring and 1st-2nd synchronizer hub spline of mainshaft.
- Replace 2nd inner baulk ring, 2nd synchronizer cone and 2nd outer baulk ring as a set.
- Be careful with the orientation 1st-2nd coupling sleeve.

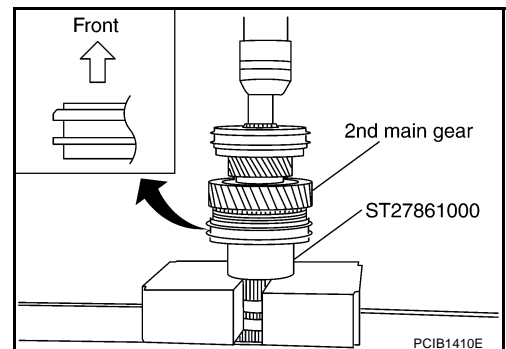



# TRANSMISSION ASSEMBLY

**NOTE:**

1st outer baulk ring has three spaces that three gear tooth is missing and 2nd outer baulk ring has three spaces that two gear teeth are missing.

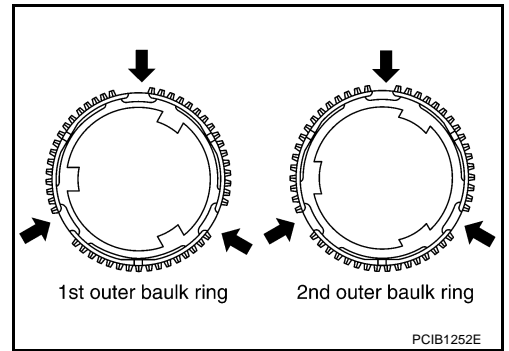

4. Press in 1st gear bushing using the support ring.
5. Install 1st outer baulk ring, 1st synchronizer cone, 1st inner baulk ring, 1st needle bearing and 1st main gear to mainshaft.

**CAUTION:**

- Apply gear oil to 1st outer baulk ring, 1st synchronizer cone, 1st inner baulk ring and 1st needle bearing.
- Replace 1st outer baulk ring, 1st synchronizer cone and 1st inner baulk ring as a set.

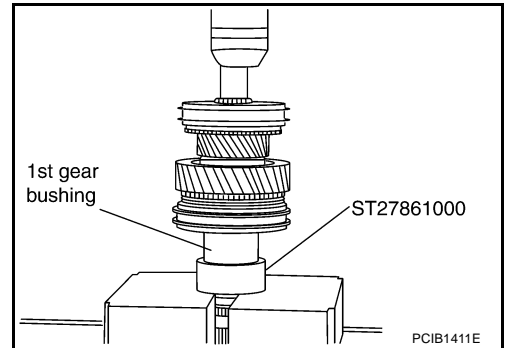

**NOTE:**

1st outer baulk ring has three spaces that three gear tooth is missing and 2nd outer baulk ring has three spaces that two gear teeth are missing.

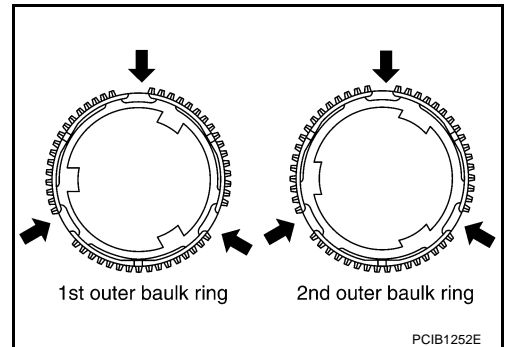

6. Press in 3rd main gear using the inserter.

**CAUTION:**

Be careful with the orientation 3rd main gear.

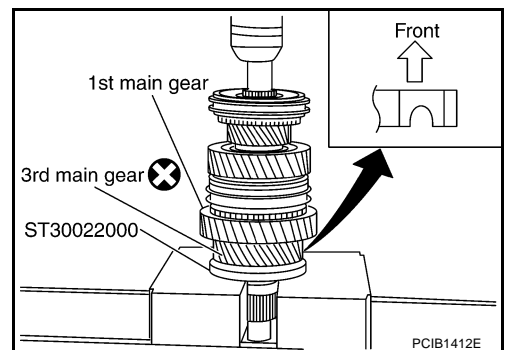

A  
B  
MT  
D  
E  
F  
G  
H  
I  
J  
K  
L  
M

# TRANSMISSION ASSEMBLY

7. Install 3rd-4th main spacer to mainshaft.
8. Press in 4th main gear using the inserter.

**CAUTION:**

**Be careful with the orientation 4th main gear.**

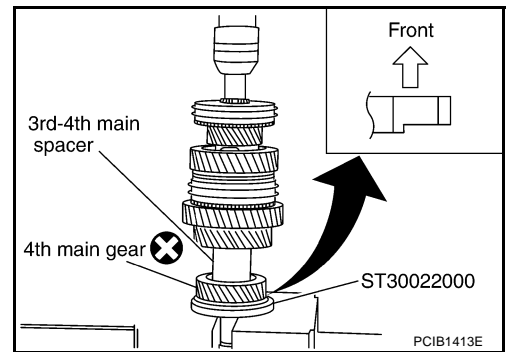

9. Press in mainshaft bearing using the inserter.

**CAUTION:**

**Be careful with the orientation mainshaft bearing.**

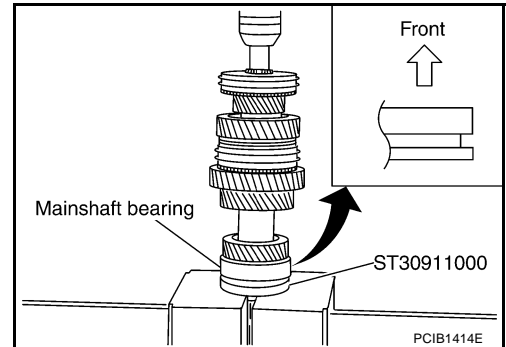

10. Press in reverse main gear bushing using the inserter.

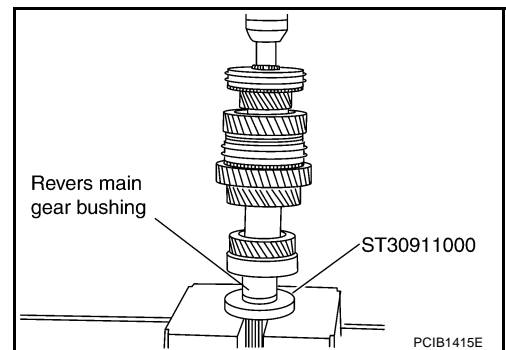

11. Press in 3rd gear bushing using the inserter.

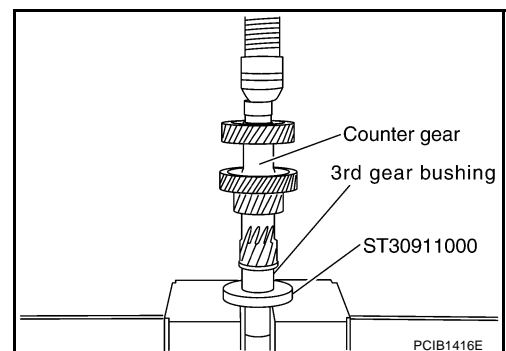

12. Install 3rd-4th synchronizer hub assembly according to the following.

- a. Install 3rd-4th coupling sleeve to 3rd-4th synchronizer hub.

**CAUTION:**

- Do not reuse 3rd-4th synchronizer hub and 3rd-4th coupling sleeve.
- Replace 3rd-4th synchronizer hub and 3rd-4th coupling sleeve as a set.

# TRANSMISSION ASSEMBLY

- Be careful with the orientation 3rd-4th coupling sleeve.

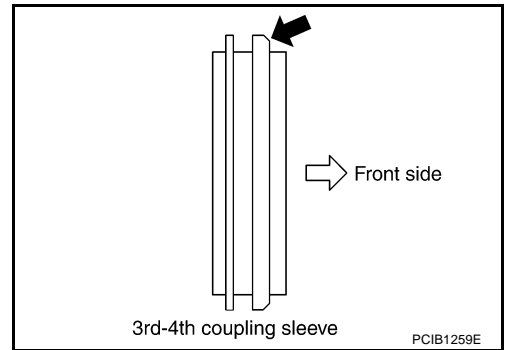

- b. Install spread springs and shifting inserts to 3rd-4th synchronizer hub.

**CAUTION:**

- Do not install spread spring hook onto the same shifting insert.

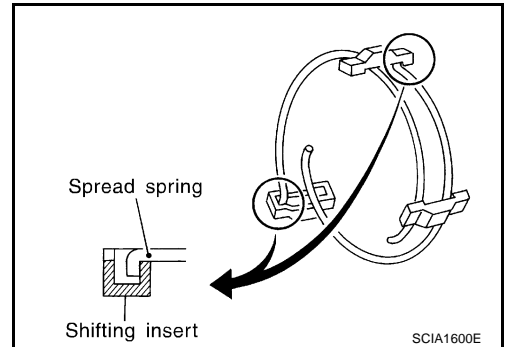

- Be careful with the shape of reverse shifting insert to avoid misassembly.

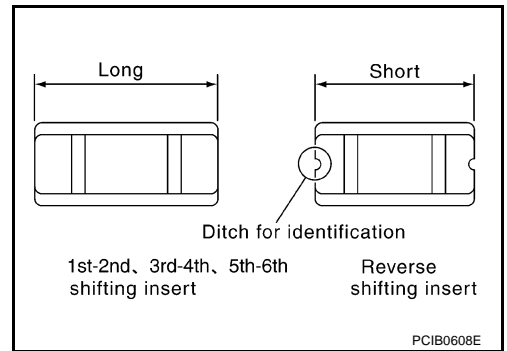

- c. Press in 3rd-4th synchronizer hub assembly, 3rd inner baulk ring, 3rd synchronizer cone, 3rd outer baulk ring, 3rd counter gear and 3rd needle bearing using the inserter.

**CAUTION:**

- Apply gear oil to 3rd inner baulk ring, 3rd synchronizer cone, 3rd outer baulk ring, 3rd needle bearing and hole spline of 3rd-4th synchronizer hub.
- Replace 3rd inner baulk ring, 3rd synchronizer cone and 3rd outer baulk ring as a set.
- Be careful with the orientation 3rd-4th coupling sleeve.

**NOTE:**

4th baulk ring has three spaces that one gear tooth is missing but 3rd baulk ring doesn't.

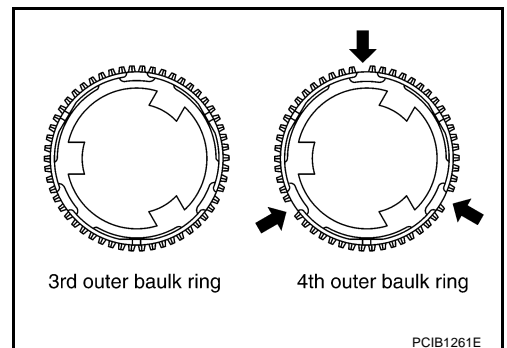
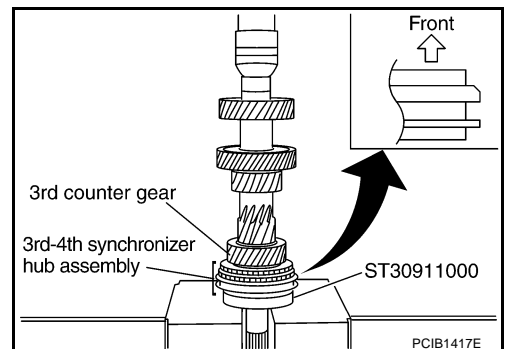

A  
B  
MT  
D  
E  
F  
G  
H  
I  
J  
K  
L  
M

# TRANSMISSION ASSEMBLY

13. Press in 4th counter gear thrust washer, 4th gear bushing, 4th needle bearing, 4th counter gear, 4th outer baulk ring, 4th synchronizer cone and 4th inner baulk ring using the inserter.

**CAUTION:**

- Apply gear oil to 4th needle bearing, 4th outer baulk ring, 4th synchronizer cone and 4th inner baulk ring.
- Replace 4th outer baulk ring, 4th synchronizer cone and 4th inner baulk ring as a set.
- Be careful with the orientation 4th counter gear thrust washer.

**NOTE:**

4th baulk ring has three spaces that one gear tooth is missing but 3rd baulk ring doesn't.

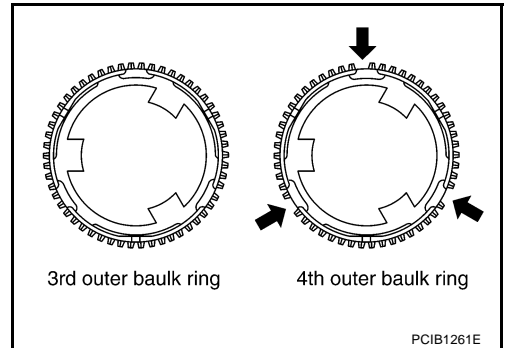
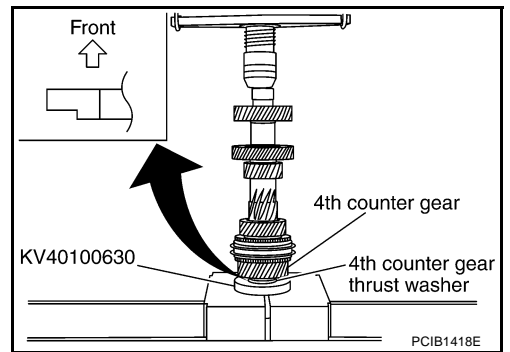

14. Press in counter rear bearing inner race using the inserter.

**CAUTION:**

- Be careful with the orientation counter rear bearing inner race.
- Replace counter rear bearing inner race, counter rear bearing and counter rear bearing spacer as a set.

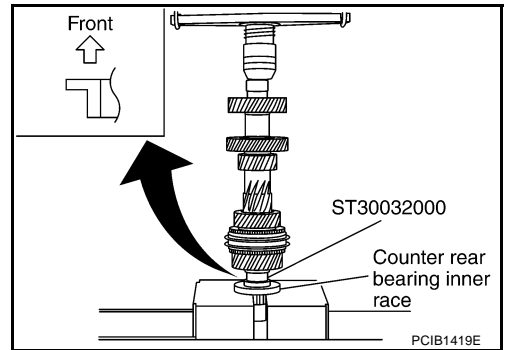

15. Install main drive gear bearing according to the following.

- a. Press in main drive gear bearing using the drift.

**CAUTION:**

Be careful with the orientation main drive gear bearing.

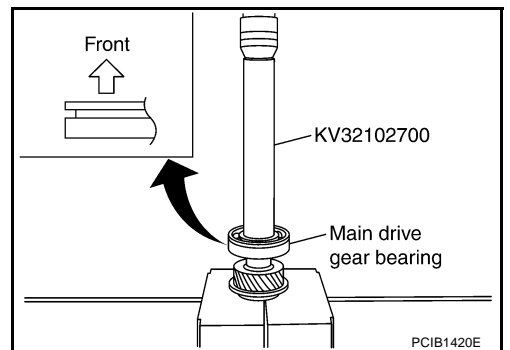

# TRANSMISSION ASSEMBLY

- b. Select and install a snap ring to main drive gear bearing so that the end play comes within the standard value. Refer to [MT-70, "Snap Rings"](#).

**End play:** 0 - 0.10 mm (0 - 0.004 in)

**CAUTION:**  
Do not reuse snap ring.

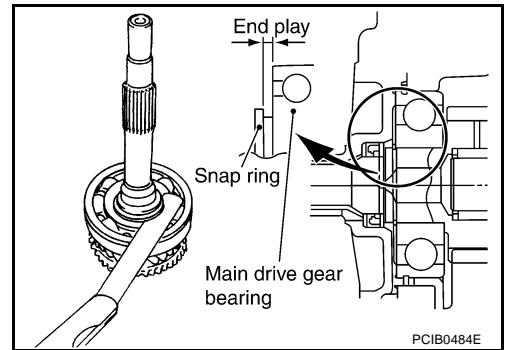

16. Install breather to adapter plate.

**CAUTION:**

- Do not reuse breather.
- Be careful with the orientation breather.

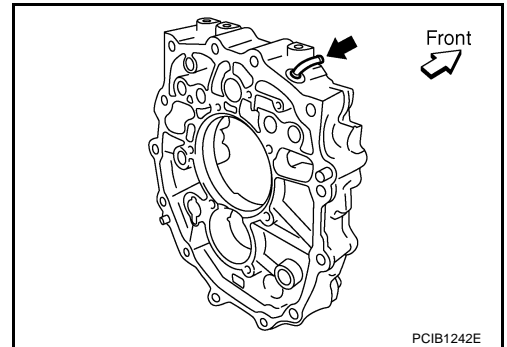

17. Install magnet to adapter plate.

**CAUTION:**  
Be careful with the orientation magnet.

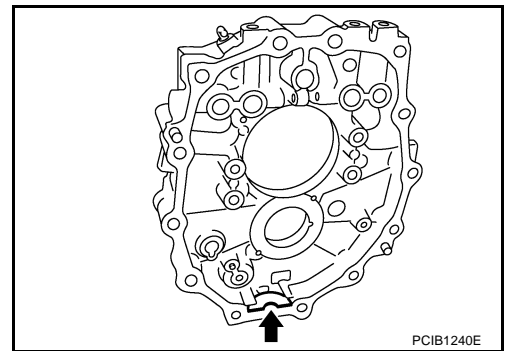

18. Install baffle plate to adapter plate, and then tighten mounting bolt to the specified torque. Refer to [MT-21, "Case Components"](#).

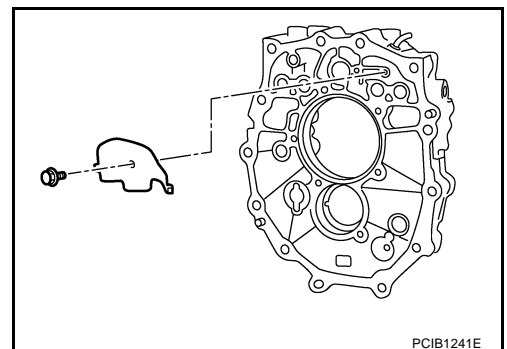

19. Install main drive gear assembly, mainshaft assembly and counter gear assembly according to the following.

A  
B  
MT  
D  
E  
F  
G  
H  
I  
J  
K  
L  
M

# TRANSMISSION ASSEMBLY

- a. Install main pilot bearing, pilot bearing spacer and 5th baulk ring to main drive gear.
- b. Install main drive gear assembly, mainshaft assembly and counter gear assembly combined in one unit to adapter plate using brass bar.

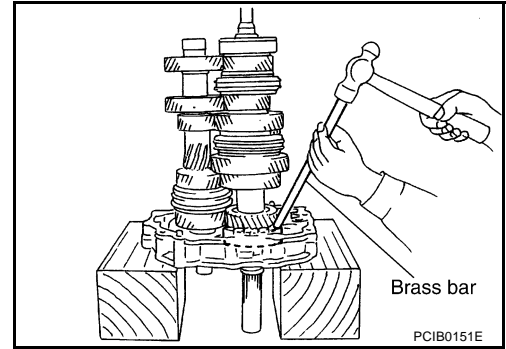

20. Install adapter setting plate to adapter plate, and then fixing in adapter setting plate using a vise.

**CAUTION:**

**Do not directly secure mating surface of adapter plate in a vice.**

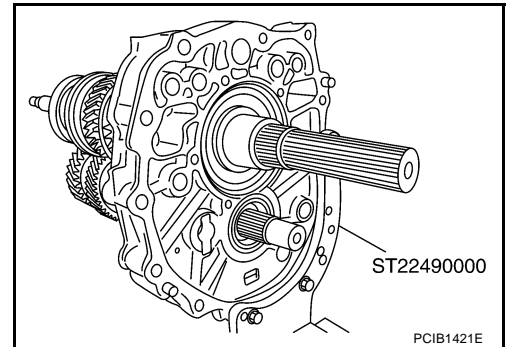

21. Install snap ring to mainshaft bearing.

**CAUTION:**

**Do not reuse snap ring.**

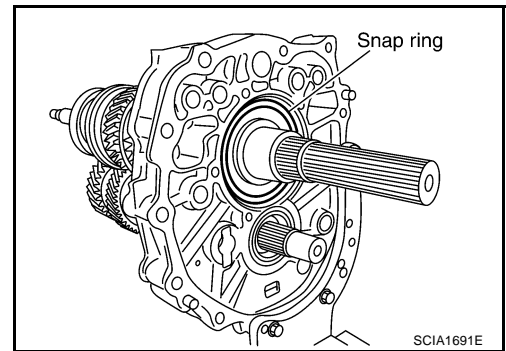

22. Install counter rear bearing to adapter plate using the drift.

**CAUTION:**

**Replace counter rear bearing inner race, counter rear bearing and counter rear bearing spacer as a set.**

23. Install counter rear bearing spacer to counter gear.

**CAUTION:**

- When installing counter rear bearing spacer, groove should face to the rear side.
- Replace counter rear bearing inner race, counter rear bearing and counter rear bearing spacer as a set.

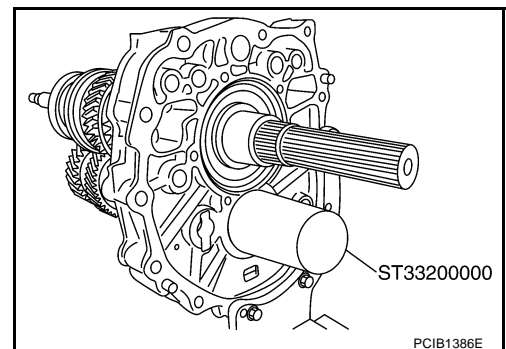

24. Install bearing retainer according to the following.

- a. Install bearing retainer to adapter plate.
- b. Apply recommended thread locking sealant to threads of bolts, and then tighten mounting bolts to the specified torque. Refer to [MT-21, "Case Components"](#).

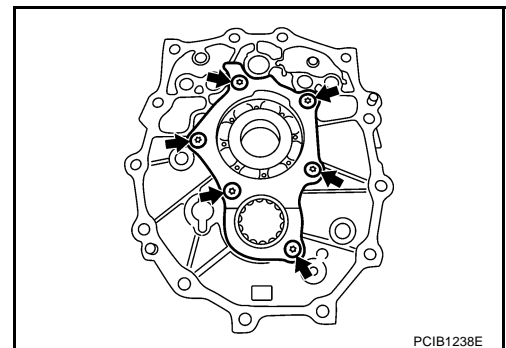

# TRANSMISSION ASSEMBLY

25. Install reverse synchronizer hub assembly according to the following.

a. Install reverse coupling sleeve to reverse synchronizer hub.

**CAUTION:**

- Do not reuse reverse coupling sleeve and reverse synchronizer hub.
- Replace reverse coupling sleeve and reverse synchronizer hub as a set.
- Be careful with the orientation reverse coupling sleeve.

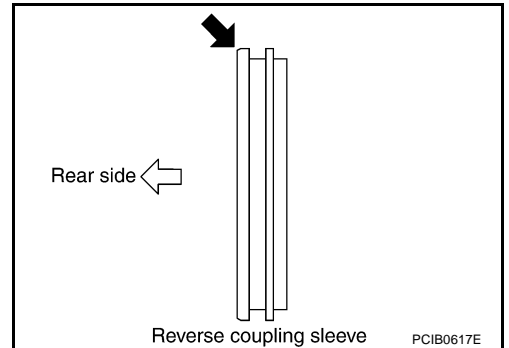

- Be careful with the orientation reverse synchronizer hub.

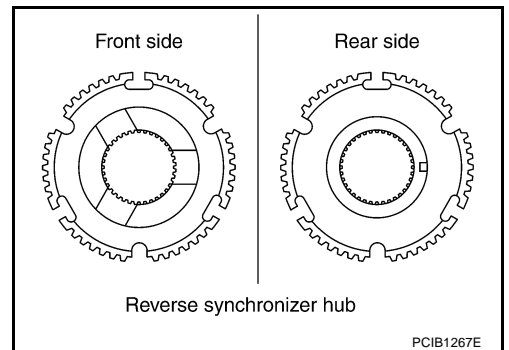

b. Install spread springs to shifting inserts to reverse synchronizer hub.

**CAUTION:**

- Do not install spread spring hook onto the same shifting insert.

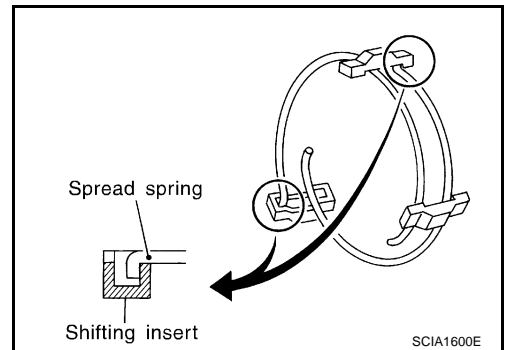

- Be careful with the shape of 1st-2nd, 3rd-4th and 5th-6th shifting insert to avoid misassembly.

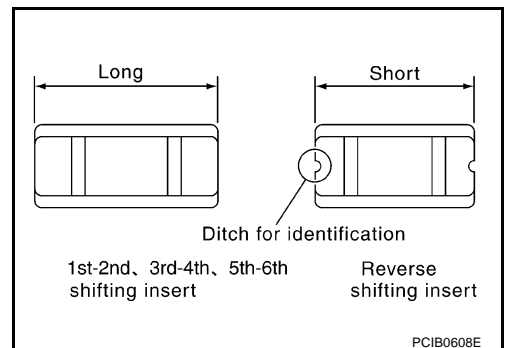

A  
B  
MT  
D  
E  
F  
G  
H  
I  
J  
K  
L  
M

# TRANSMISSION ASSEMBLY

c. Install snap ring to reverse synchronizer hub.

**CAUTION:**

- Do not reuse snap ring.
- Do not align the snap ring notch with synchronizer hub groove when assembling.

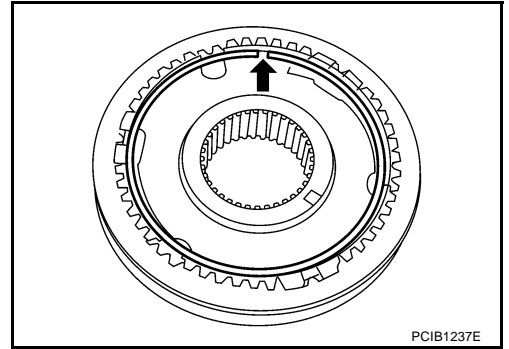

d. Press in reverse synchronizer hub assembly, reverse baulk ring, reverse main gear and reverse main needle bearing using the drift and press plate.

**CAUTION:**

- Apply gear oil to reverse baulk ring and reverse main needle bearing.
- Be careful with the orientation reverse coupling sleeve.

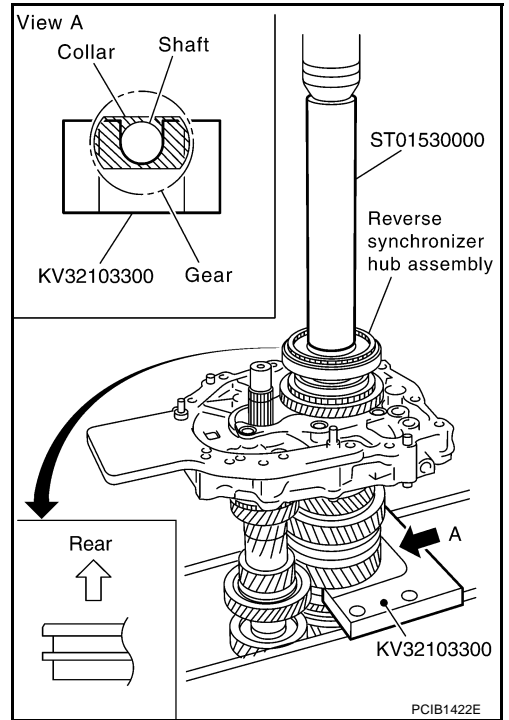

**NOTE:**

Reverse baulk ring has three spaces that two gear teeth are missing, and each space has small ditch for identification as shown in the figure.

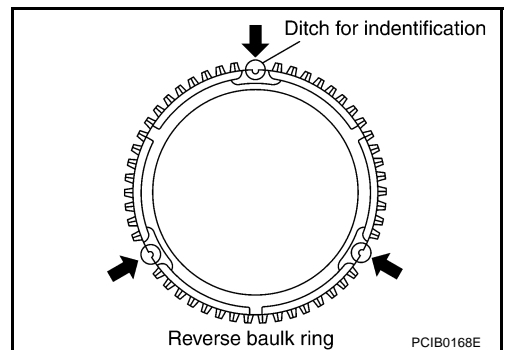



# TRANSMISSION ASSEMBLY

26. Select and install a snap ring so that the end play comes within the standard value. Refer to [MT-70, "Snap Rings"](#) .

**End play:**            **0 - 0.10 mm (0 - 0.004 in)**

**CAUTION:**  
**Do not reuse snap ring.**

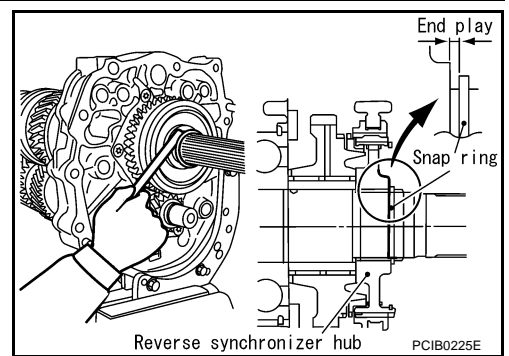

27. Press in reverse counter gear using the drift.

**CAUTION:**  
**Be careful with the orientation counter gear.**

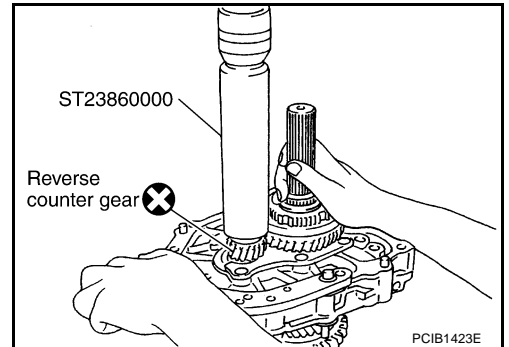

28. Select and install a snap ring so that the end play comes within the standard value. Refer to [MT-70, "Snap Rings"](#) .

**End play:**            **0 - 0.10 mm (0 - 0.004 in)**

**CAUTION:**  
**Do not reuse snap ring.**

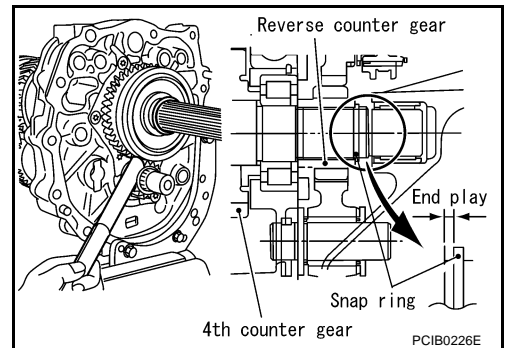

29. Install reverse idler shaft assembly according to the following.

- a. Install reverse idler needle bearing, reverse idler gear and reverse idler thrust washer to reverse idler shaft.

**CAUTION:**  
**Apply gear oil to reverse idler needle bearing.**

- b. Install reverse idler shaft assembly to adapter plate.

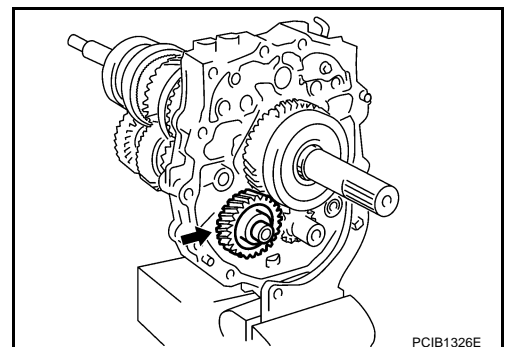

## Shift Control Components

1. Install main drive gear assembly, mainshaft assembly, counter gear assembly and reverse idler shaft assembly. Refer to [MT-46, "Gear Components"](#) .
2. Install striking rod assembly according to the following.

A  
B  
MT  
D  
E  
F  
G  
H  
I  
J  
K  
L  
M

# TRANSMISSION ASSEMBLY

- a. Install striking rod assembly to adapter plate.

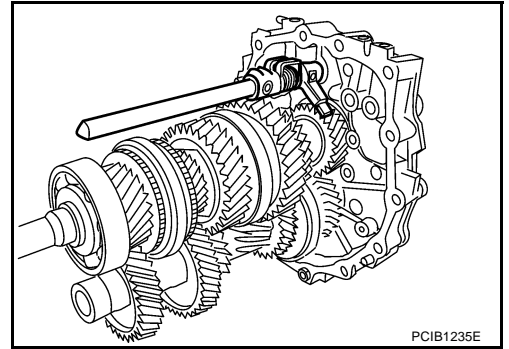

- b. Install stopper ring to striking rod assembly.  
c. Install retaining pin onto stopper ring using a pin punch.

**CAUTION:**

**Do not reuse retaining pin.**

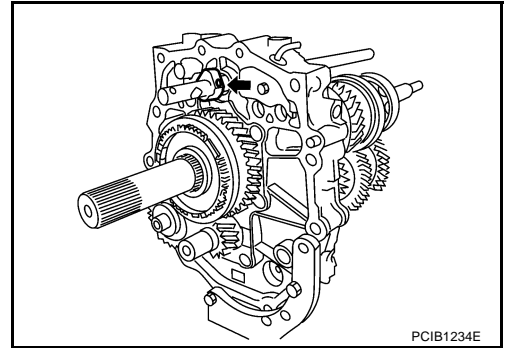

3. Install 5th-6th fork rod (reversal side) according to the following.

- a. Install 5th-6th shift fork to 5th-6th coupling sleeve.  
b. Install 5th-6th fork rod (reversal side) to 5th-6th shift fork.  
c. Install retaining pin onto 5th-6th shift fork using a pin punch.

**CAUTION:**

**Do not reuse retaining pin.**

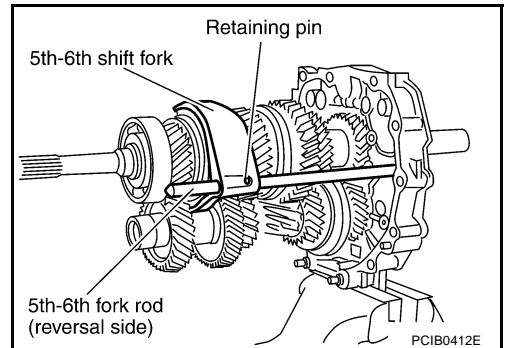

4. Install 5th-6th control lever to adapter plate, and then tighten mounting bolts to the specified torque. Refer to [MT-25, "Shift Control Components"](#) .

**CAUTION:**

**Install 5th-6th control lever with projection side at upward.**

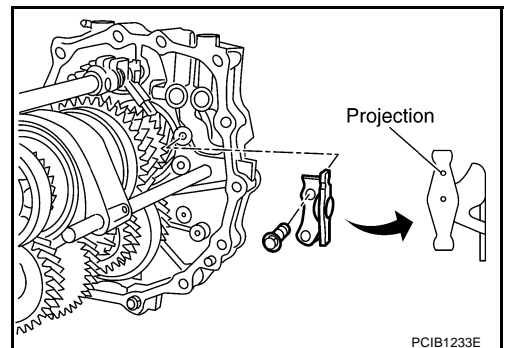

5. Install 5th-6th fork rod according to the following.

# TRANSMISSION ASSEMBLY

- a. Install 5th-6th fork bracket and 5th-6th fork rod to adapter plate.
- b. Install retaining pin onto 5th-6th fork bracket using a pin punch.

**CAUTION:**

**Do not reuse retaining pin.**

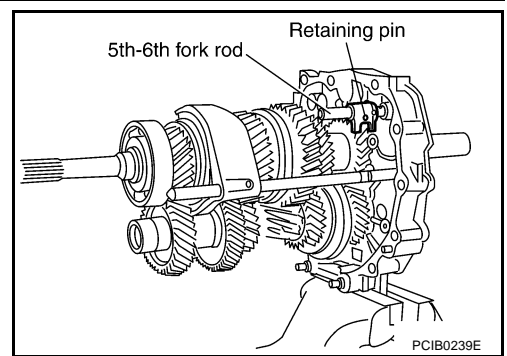

6. Install check balls to adapter plate.

**CAUTION:**

**Apply gear oil to check ball.**

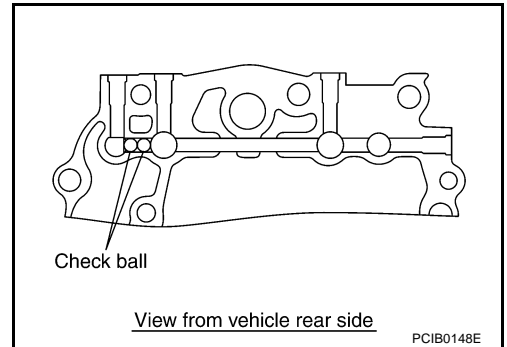

7. Install reverse fork rod according to the following.
  - a. Install reverse shift fork to reverse coupling sleeve.
  - b. Install reverse fork rod to reverse shift fork.
  - c. Install retaining pin onto reverse shift fork using a pin punch.

**CAUTION:**

**Do not reuse retaining pin.**

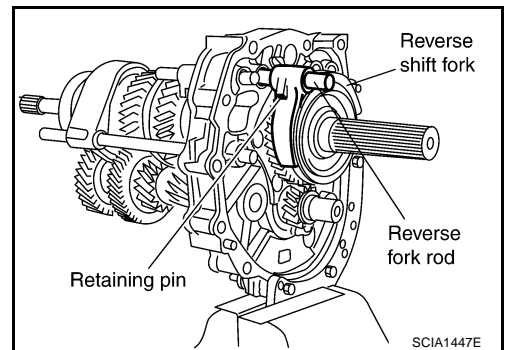

8. Install interlock pin and interlock plunger to adapter plate.

**CAUTION:**

**Apply gear oil to interlock pin and interlock plunger.**

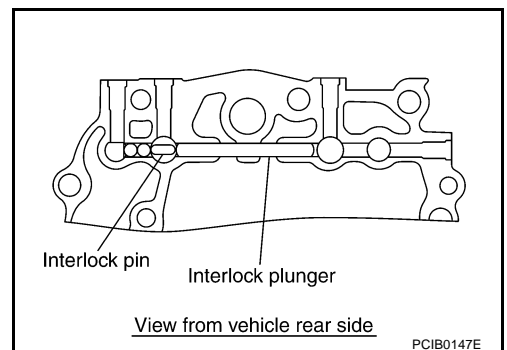

9. Install 1st-2nd fork rod according to the following.

A  
B  
MT  
D  
E  
F  
G  
H  
I  
J  
K  
L  
M

# TRANSMISSION ASSEMBLY

- a. Install 1st-2nd shift fork to 1st-2nd coupling sleeve.
- b. Install 1st-2nd fork rod to 1st-2nd shift fork.
- c. Install retaining pin onto 1st-2nd shift fork using a pin punch.

**CAUTION:**

**Do not reuse retaining pin.**

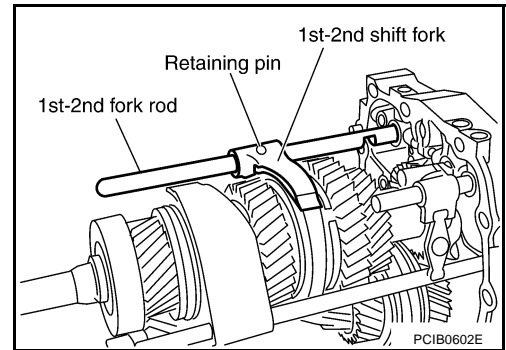

10. Install interlock pin and check balls to adapter plate.

**CAUTION:**

**Apply gear oil to interlock pin and check ball.**

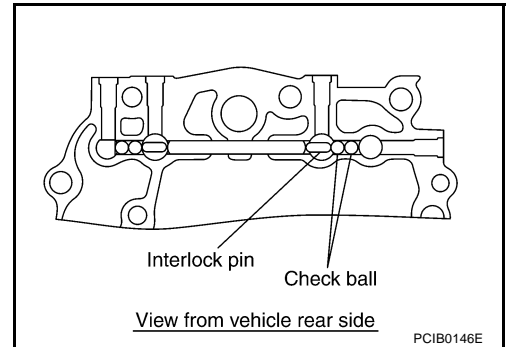

11. Install 3rd-4th fork rod (reversal side) according to the following.

- a. Install 3rd-4th shift fork to 3rd-4th coupling sleeve.
- b. Install 3rd-4th fork rod (reversal side) to 3rd-4th shift fork.
- c. Install retaining pin onto 3rd-4th shift fork using a pin punch.

**CAUTION:**

**Do not reuse retaining pin.**

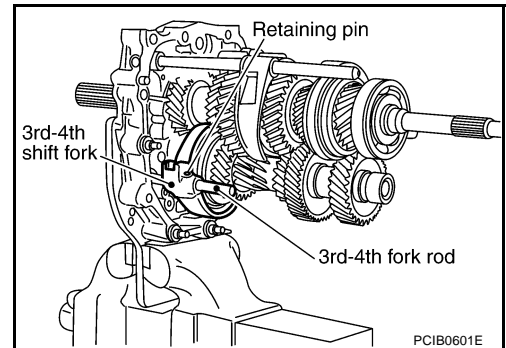

12. Install 3rd-4th fork rod according to the following.

- a. Install 3rd-4th fork rod to adapter plate.
- b. Install 3rd-4th fork rod bracket to 3rd-4th fork rod.
- c. Install retaining pin onto 3rd-4th fork rod bracket using a pin punch.

**CAUTION:**

**Do not reuse retaining pin.**

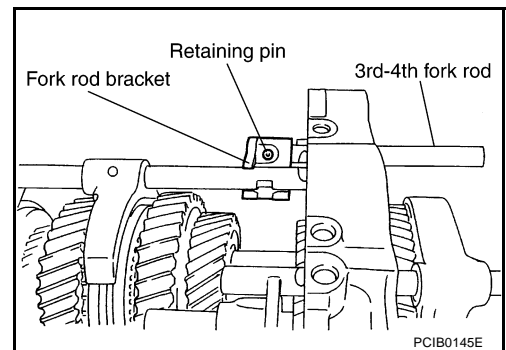

13. Install 3rd-4th control lever according to the following.

# TRANSMISSION ASSEMBLY

- a. Install shifter cap to 3rd-4th control lever.
- b. Install 3rd-4th control lever to adapter plate, and then tighten mounting bolts to the specified torque. Refer to [MT-25, "Shift Control Components"](#).

**CAUTION:**

**Be careful with the orientation 3rd-4th control lever.**

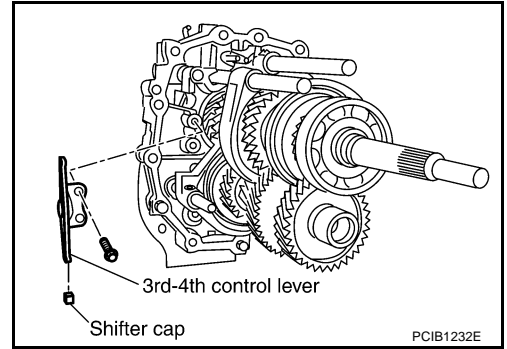

14. Install check ball plugs according to the following.
  - a. Install check balls and check ball springs to adapter plate.
  - b. Apply recommended sealant to threads of check ball plugs, and tighten check ball plugs to the specified torque. Refer to [MT-25, "Shift Control Components"](#).

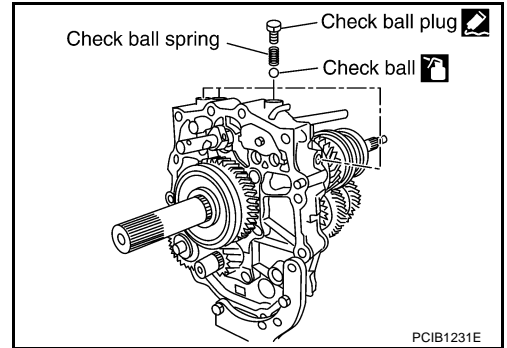

15. Install baffle plate to adapter plate, and then tighten mounting bolt to the specified torque. Refer to [MT-21, "Case Components"](#).

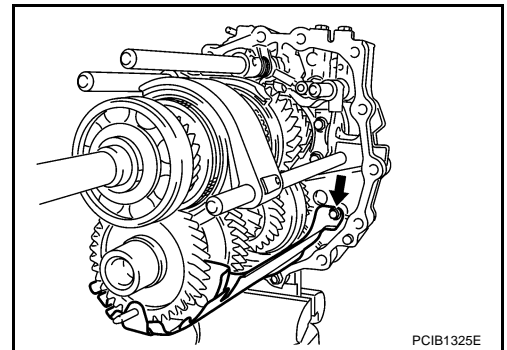

## Case Components

1. Install main drive gear assembly, mainshaft assembly, counter gear assembly and reverse idler shaft assembly. Refer to [MT-46, "Gear Components"](#).
2. Install fork rods and shift forks. Refer to [MT-57, "Shift Control Components"](#).
3. Install oil gutter to transmission case.

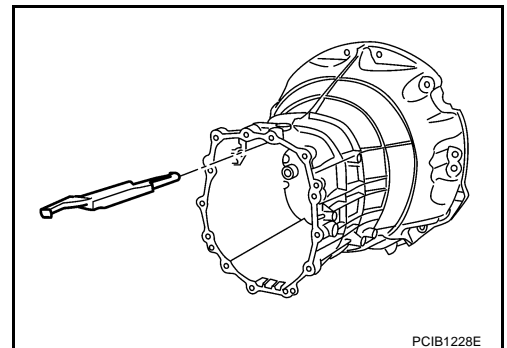

A  
B  
MT  
D  
E  
F  
G  
H  
I  
J  
K  
L  
M

# TRANSMISSION ASSEMBLY

4. Install counter front bearing to transmission case.

**CAUTION:**

Apply multi-purpose grease to rollers of counter front bearing.

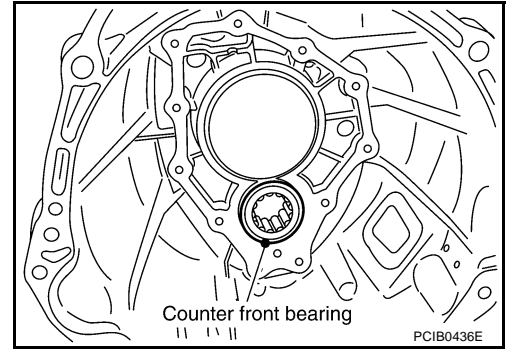

5. Apply recommended sealant to mating surface of transmission case as shown in the figure.

**CAUTION:**

Remove old sealant adhering to the mating surfaces. Also remove any moisture, oil, or foreign material adhering to both mating surfaces.

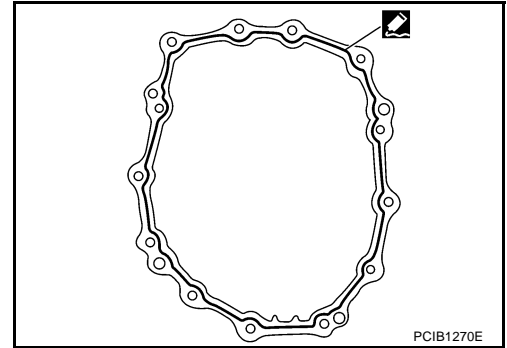

6. Install transmission case to adapter plate assembly.

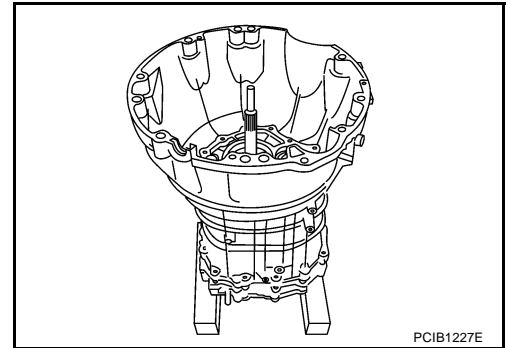

7. Install snap ring to main drive gear bearing using a snap ring pliers.

**CAUTION:**

Do not reuse snap ring.

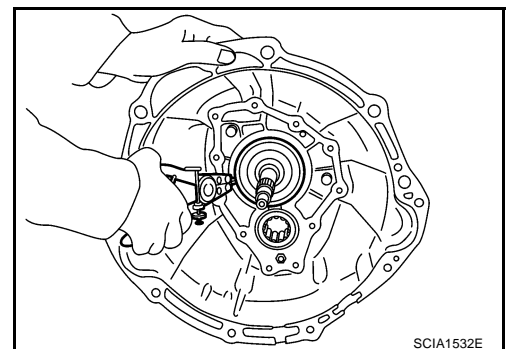

8. Tighten baffle plate mounting nut to the specified torque. Refer to [MT-21, "Case Components"](#).

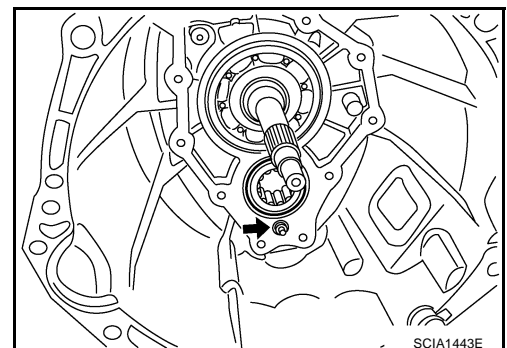

# TRANSMISSION ASSEMBLY

9. Tighten baffle plate mounting bolt to the specified torque. Refer to [MT-21, "Case Components"](#) .

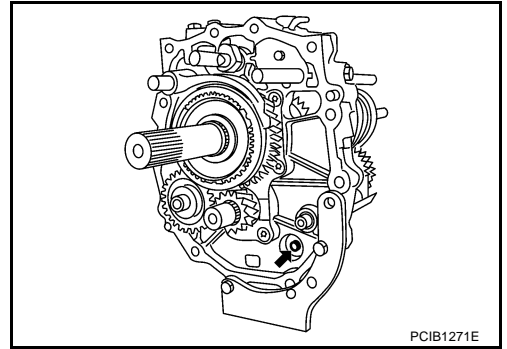

10. Install front cover oil seal to front cover using the drift.

**Dimension "A": 8.55 - 9.55 (0.336 - 0.376 in)**

**CAUTION:**  
When installing, do not incline front cover oil seal.

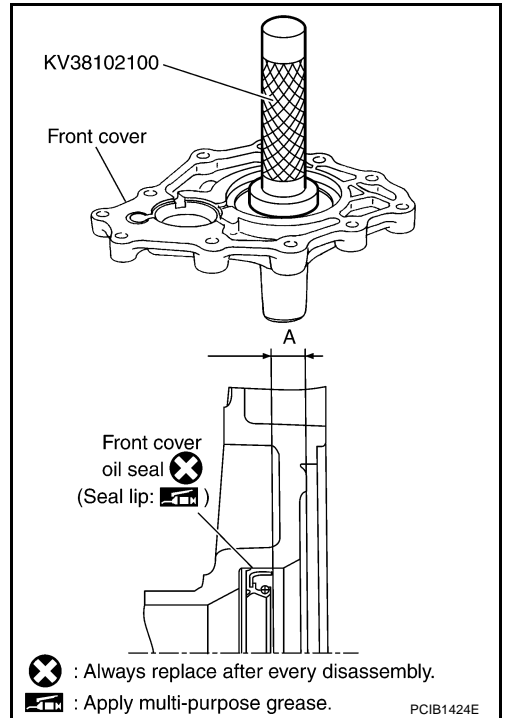

11. Install front cover according to the following.

- a. Install front cover gasket and front cover to transmission case.

- CAUTION:**
- Do not reuse front cover gasket.
  - Remove any moisture, oil, or foreign material adhering to both mating surfaces.
  - Do not damage front cover oil seal.

- b. Temporary tightening 2 bolts in the positions shown in the figure.
- c. Temporary tightening remaining 9 bolts.

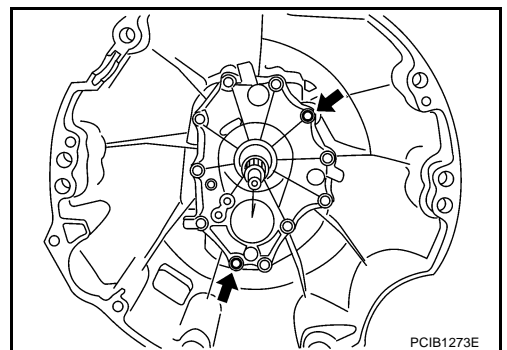

A  
B  
MT  
D  
E  
F  
G  
H  
I  
J  
K  
L  
M

# TRANSMISSION ASSEMBLY

- d. Tighten bolts to the specified torque in order as shown on the figure. Refer to [MT-21, "Case Components"](#).

**CAUTION:**

**Do not reuse bolts indicated as A in the figure.**

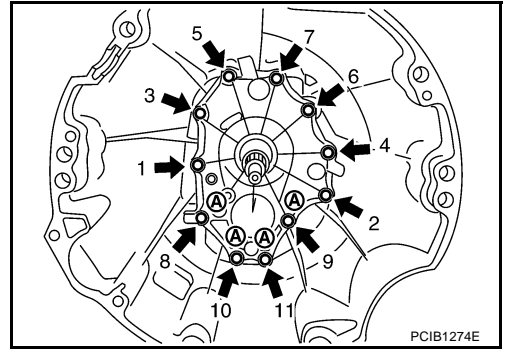

12. Install washer to withdrawal lever ball pin, and then install it to front cover. Tighten withdrawal lever ball pin to the specified torque. Refer to [MT-21, "Case Components"](#).

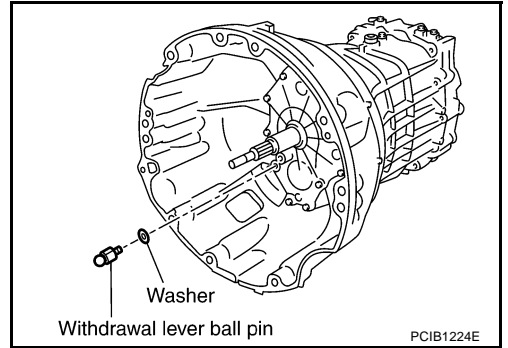

13. Install counter end bearing to rear extension (or OD gear case) using a suitable drift [32 mm (1.26 in) dia.].

**Dimension "A": 0.5 - 1.5 (0.020 - 0.059 in)**

**CAUTION:**

**Install counter end bearing with maker stamp at upper side.**

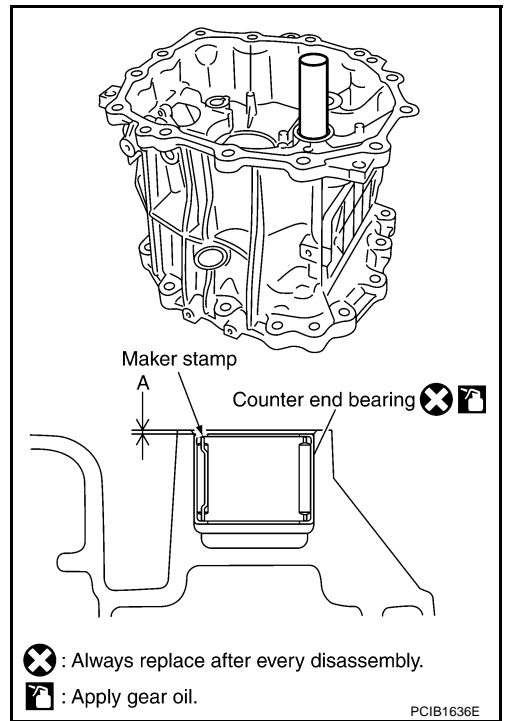



# TRANSMISSION ASSEMBLY

14. Install rear oil seal (1) to rear extension (or OD gear case) using the drift.

**Tool number**     **A: ST33200000**

**Dimension "H1 "**

**2WD models:**            **1.2 - 2.2 mm (0.047 - 0.087 in)**

**4WD models:**            **-0.5 - 0.5 mm (-0.020 - 0.020 in)**

**CAUTION:**

**When installing, do not incline rear oil seal.**

(B): Seal lip

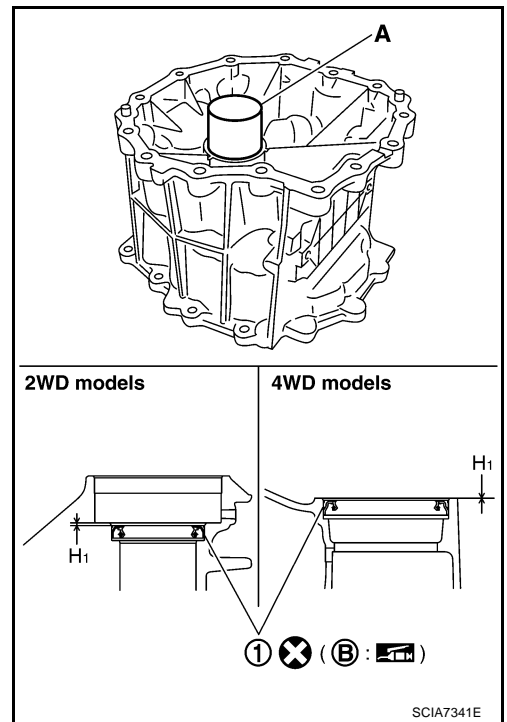

15. Install dust seal (1) to rear extension using the drift (for 2WD models).

**Tool number**     **A: KV38100500**

**Dimension "H2 ":**     **0.5 - 1.5 mm (0.020 - 0.059 in)**

**CAUTION:**

**When installing, do not incline dust seal.**

(B): Seal lip

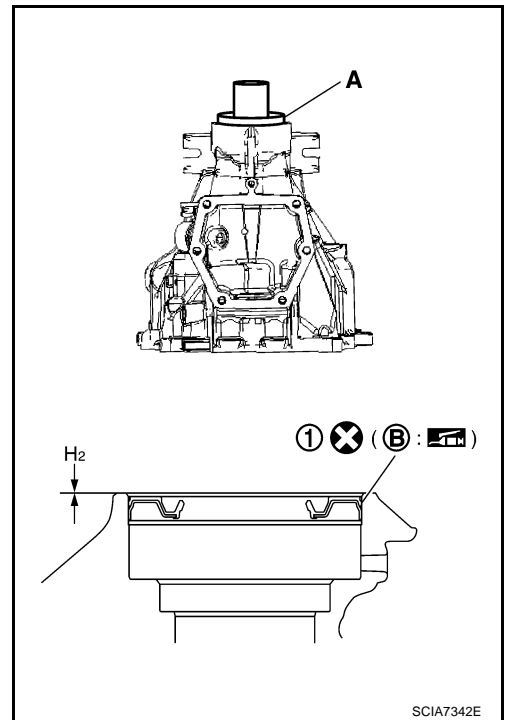

16. Install rear extension oil gutter according to the following (for 2WD models).

- a. Install cap to rear extension oil gutter.
- b. Install rear extension oil gutter to rear extension, and then tighten mounting bolt to specified torque. Refer to [MT-21, "Case Components"](#) .

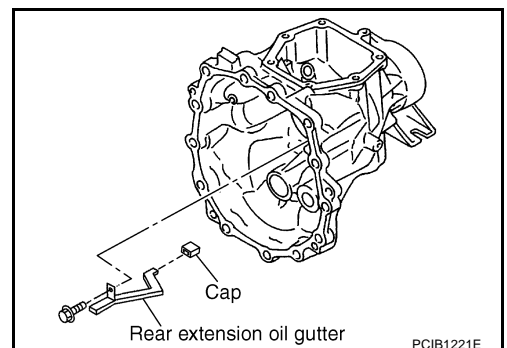

# TRANSMISSION ASSEMBLY

17. Apply recommended sealant to mating surface of rear extension (or OD gear case) as shown in the figure.

**CAUTION:**

Remove old sealant adhering to the mating surfaces. Also remove any moisture, oil, or foreign material adhering to both mating surfaces.

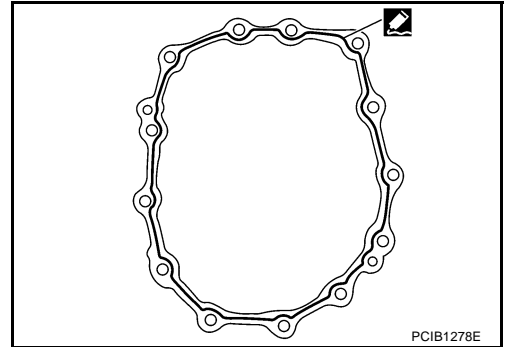

18. Install rear extension (or OD gear case) to adapter plate, and then tighten mounting bolts in order as shown on the figure. Refer to [MT-21, "Case Components"](#) .

**CAUTION:**

Do not damage rear oil seal and dust seal (for 2WD models).

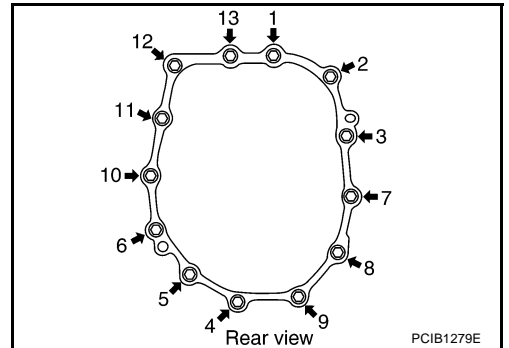

19. Install check shift pin and pivot bolt to transmission case, and then tighten them to the specified torque. Refer to [MT-21, "Case Components"](#) .

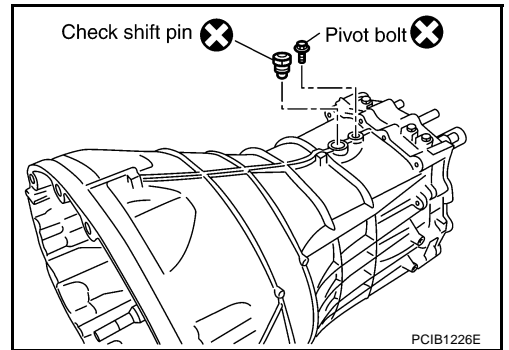

20. Install return spring plunger, return spring and return spring plug to rear extension (or OD gear case), and then tighten return spring plug to the specified torque. Refer to [MT-25, "Shift Control Components"](#) .

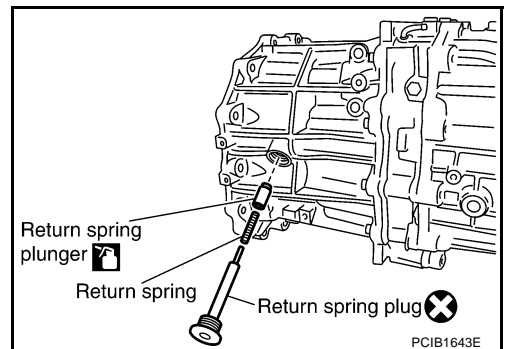

21. Install park/neutral position (PNP) switch and back-up lamp switch according to the following.

# TRANSMISSION ASSEMBLY

- a. Install plungers to rear extension (or OD gear case).
- b. Apply recommended sealant to threads of park/neutral position (PNP) switch and back-up lamp switch.
- c. Install park/neutral position (PNP) switch and back-up lamp switch to rear extension (or OD gear case), and tighten them to the specified torque. Refer to [MT-21, "Case Components"](#) .

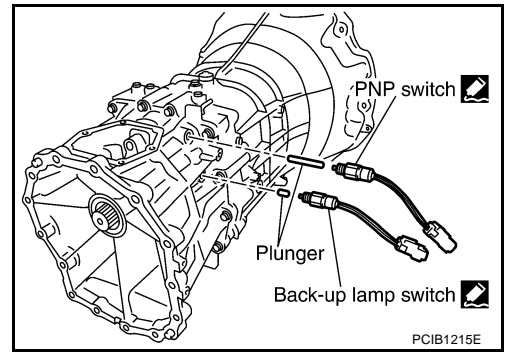

22. Install clips to PNP switch and back-up lamp switch.

**CAUTION:**

- Thread harness through the notch of clip.

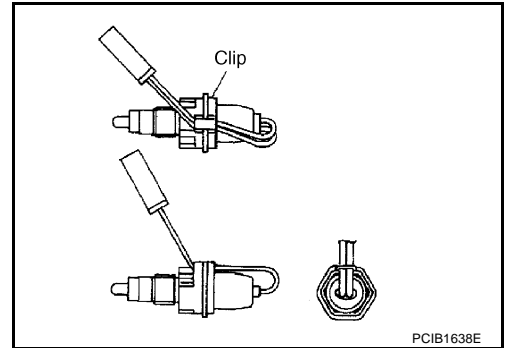

- Be careful when threading harness as shown in the figure.

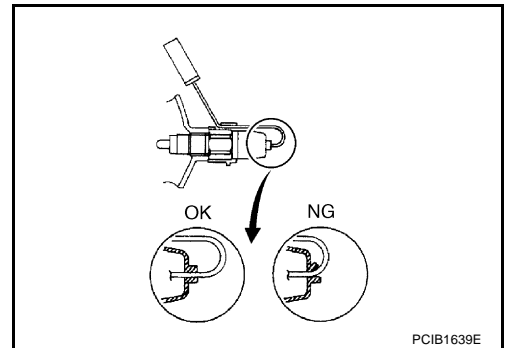

23. Install striking arm according to the following.

- a. Install striking arm to striking rod assembly.
- b. Install retaining pin to striking arm using a pin punch.

**CAUTION:**

**Do not reuse retaining pin.**

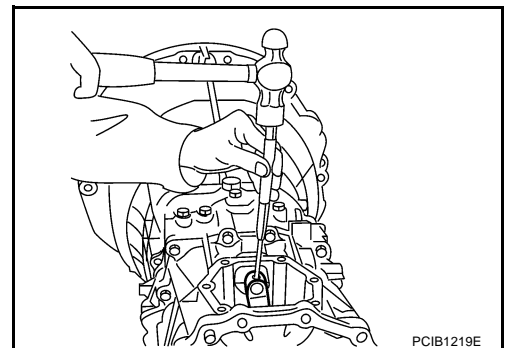

24. Install control housing according to the following.

A  
B  
MT  
D  
E  
F  
G  
H  
I  
J  
K  
L  
M

# TRANSMISSION ASSEMBLY

- a. Install gasket and control housing to rear extension (or OD gear case).

**CAUTION:**

- Do not reuse gasket.
- Remove any moisture, oil, or foreign material adhering to both mating surfaces.

- b. Tighten mounting bolts to the specified torque in order as shown on the figure. Refer to [MT-21, "Case Components"](#).

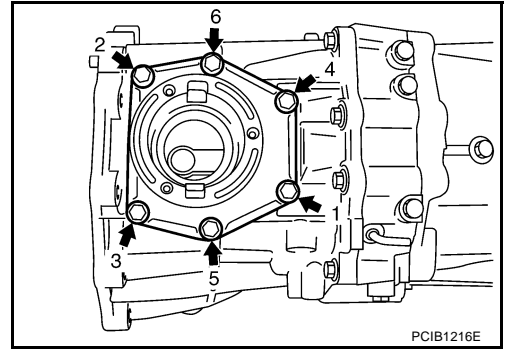

25. Install gasket to drain plug, and then install it to transmission case. Tighten drain plug to the specified torque. Refer to [MT-21, "Case Components"](#).

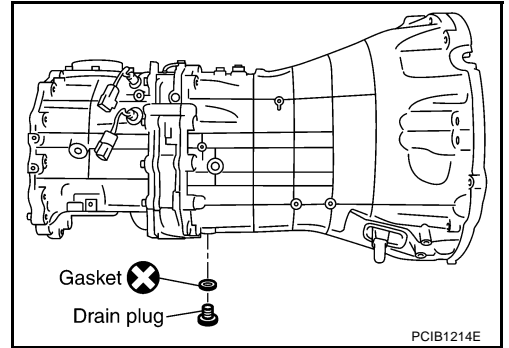

26. Install gasket to filler plug, and then install it to transmission case. Tighten filler plug to the specified torque. Refer to [MT-21, "Case Components"](#).

**CAUTION:**

**After oil is filled, tighten filler plug to specified torque.**

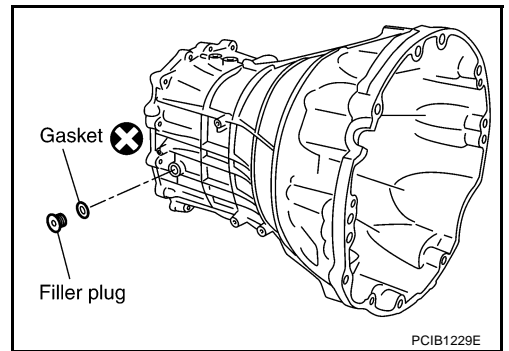

# SERVICE DATA AND SPECIFICATIONS (SDS)

## SERVICE DATA AND SPECIFICATIONS (SDS)

PFP:00030

### General Specifications

GCS00010

Engine type		VQ40DE		YD25DDTi	
Transmission model		FS6R31A			
Axle type		2WD	4WD	2WD	4WD
Number of speed		6			
Synchromesh type		Warner			
Shift pattern		<p style="text-align: center;">SCIA0955E</p>			
Gear ratio	1st	4.368		4.692	
	2nd	2.518		2.705	
	3rd	1.743		1.747	
	4th	1.283		1.291	
	5th	1.000			
	6th	0.769		0.827	
	Reverse	3.966		4.260	
Main gear (Number of teeth)	Drive	24		23	
	1st	37			
	2nd	32			
	3rd	32		31	
	4th	29		28	
	6th	25			
	Reverse	42			
Counter gear (Number of teeth)	Drive	34		35	
	1st	12			
	2nd	18			
	3rd	26		27	
	4th	32		33	
	6th	46			
	Reverse	15			
Reverse idler gear (Number of teeth)		26			
Oil capacity (Approx.)		<i>ℓ</i> (Imp pt)		3.98 (7)	4.32 (7-5/8)
Remarks	Reverse synchronizer	Installed			
	Double cone synchronizer	1st, 3rd and 4th			
	Triple cone synchronizer	2nd			

# SERVICE DATA AND SPECIFICATIONS (SDS)

## Gear End Play

GCS00011

Unit: mm (in)

Item	Standard value
Counter gear	0 - 0.10 (0 - 0.004)
Main drive gear	0 - 0.10 (0 - 0.004)
Mainshaft (Front side)	0 - 0.10 (0 - 0.004)
Mainshaft (Rear side)	0 - 0.10 (0 - 0.004)

## Snap Rings

GCS00012

Unit: mm (in)

Selective parts	Thickness	Part number*	
Main drive gear	1.89 (0.0744)	32204 01G60	
	1.95 (0.0768)	32204 01G61	
	1.99 (0.0783)	32204 01G62	
	2.03 (0.0799)	32204 01G63	
	2.07 (0.0815)	32204 01G64	
	2.11 (0.0831)	32204 01G65	
Counter gear	1.96 (0.0772)	32236 CD000	
	2.02 (0.0795)	32236 CD001	
	2.08 (0.0819)	32236 CD002	
	2.14 (0.0843)	32236 CD003	
	2.20 (0.0866)	32236 CD004	
	2.26 (0.0890)	32236 CD005	
	2.32 (0.0913)	32236 CD006	
	2.38 (0.0937)	32236 CD007	
	2.44 (0.0961)	32236 CD008	
	2.50 (0.0984)	32236 CD009	
	2.56 (0.1008)	32236 CD010	
2.62 (0.1031)	32236 CD011		
Mainshaft	Front side	2.08 (0.0819)	32204 CD000
		2.14 (0.0843)	32204 CD001
		2.20 (0.0866)	32204 CD002
		2.26 (0.0890)	32204 CD003
	Rear side	2.08 (0.0819)	32204 CD000
		2.14 (0.0843)	32204 CD001
		2.20 (0.0866)	32204 CD002
		2.26 (0.0890)	32204 CD003
		2.32 (0.0913)	32204 CD004
		2.38 (0.0937)	32204 CD005
		2.44 (0.0961)	32204 CD006
		2.50 (0.0984)	32204 CD007
		2.56 (0.1008)	32204 CD008
		2.62 (0.1031)	32204 CD009
2.68 (0.1055)	32204 CD010		
2.74 (0.1079)	32204 CD011		
2.80 (0.1102)	32204 CD012		
2.86 (0.1126)	32204 CD013		
2.92 (0.1150)	32204 CD014		
2.98 (0.1173)	32204 CD015		

\*: Always check with the Parts Department for the latest parts information.

# SERVICE DATA AND SPECIFICATIONS (SDS)

## Baulk Ring Clearance

GCS00013

Unit: mm (in)

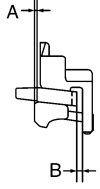
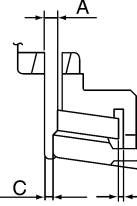
Measurement point		Standard value	Limit value
1st, 3rd and 4th (Double-cone synchronizer)	Clearance between synchronizer cone and inner baulk ring end face "A"	0.5 - 0.7 (0.020 - 0.028)	0.3 (0.012)
	Clearance between outer baulk ring pawl and synchronizer cone "B"	1st: 1.0 - 1.5 (0.039 - 0.059) 3rd: 0.85 - 1.35 (0.0335 - 0.0531) 4th: 0.85 - 1.35 (0.0335 - 0.0531)	0.7 (0.028)
 <p>PCIB0249E</p>			
2nd (Triple-cone synchronizer)	Clearance between synchronizer and clutch gear end face "A"	0.6 - 1.3 (0.024 - 0.051)	0.3 (0.012)
	Clearance between outer baulk ring pawl and synchronizer cone "B"	0.85 - 1.35 (0.0335 - 0.0531)	0.7 (0.028)
	Clearance between inner baulk ring and clutch gear end face "C"	0.7 - 1.25 (0.028 - 0.0492)	0.3 (0.012)
 <p>PCIB0835J</p>			
5th and 6th		0.7 - 1.35 (0.028 - 0.0531)	0.5 (0.020)
Reverse		0.75 - 1.2 (0.0295 - 0.047)	0.5 (0.020)

A  
B  
MT  
D  
E  
F  
G  
H  
I  
J  
K  
L  
M

# SERVICE DATA AND SPECIFICATIONS (SDS)

---