

SECTION **PR**
PROPELLER SHAFT

A
B
C

PR

CONTENTS

E

NOISE, VIBRATION, AND HARSHNESS (NVH)		
TROUBLESHOOTING	2	
NVH Troubleshooting Chart	2	
FRONT PROPELLER SHAFT	3	
On-Vehicle Service	3	
APPEARANCE AND NOISE INSPECTION	3	
PROPELLER SHAFT VIBRATION	3	
Removal and Installation	4	
COMPONENTS	4	
REMOVAL	4	
INSPECTION	4	
INSTALLATION	5	
Disassembly and Assembly	5	
DISASSEMBLY	5	
ASSEMBLY	6	
REAR PROPELLER SHAFT	7	
On-Vehicle Service	7	F
APPEARANCE AND NOISE INSPECTION	7	
PROPELLER SHAFT VIBRATION	7	
Removal and Installation	8	G
COMPONENTS (2WD)	8	
COMPONENTS (4WD)	8	
REMOVAL	9	
INSPECTION	9	H
INSTALLATION	10	
Disassembly and Assembly	10	
DISASSEMBLY	10	I
ASSEMBLY	11	
SERVICE DATA AND SPECIFICATIONS (SDS)	12	
General Specifications	12	J
Snap Ring	12	

K
L
M

NOISE, VIBRATION, AND HARSHNESS (NVH) TROUBLESHOOTING

NOISE, VIBRATION, AND HARSHNESS (NVH) TROUBLESHOOTING

PFP:00003

NVH Troubleshooting Chart

GDS0001L

Use the chart below to help you find the cause of the symptom. If necessary, repair or replace these parts.

Symptom		Possible cause and suspected parts											
		Uneven rotation torque	Rotation imbalance	Excessive runout	Differential	Axle	Suspension	Tires	Road wheel	Drive shaft	Axle shaft	Brakes	Steering
Reference page		PR-3 (front) PR-7 (rear)	PR-3 (front) PR-7 (rear)	PR-3 (front) PR-7 (rear)	RFD-7, "NVH Troubleshooting Chart" RFD-40, "NVH Troubleshooting Chart"	FAX-4, "NVH Troubleshooting Chart" RAX-5, "NVH Troubleshooting Chart"	FSU-5, "NVH Troubleshooting Chart" RSU-4, "NVH Troubleshooting Chart"	WT-2, "NVH Troubleshooting Chart"	WT-2, "NVH Troubleshooting Chart"	FAX-4, "NVH Troubleshooting Chart"	RAX-5, "NVH Troubleshooting Chart"	BR-5, "NVH Troubleshooting Chart"	PS-5, "NVH Troubleshooting Chart"
Noise		×	×	×	×	×	×	×	×	×	×	×	×
Shake						×	×	×	×	×	×	×	×
Vibration		×	×	×		×	×	×		×	×		×

×: Applicable

FRONT PROPELLER SHAFT

FRONT PROPELLER SHAFT

PFP:37200

On-Vehicle Service

GDS0001M

APPEARANCE AND NOISE INSPECTION

- Check the propeller shaft tube surface for dents or cracks. If damaged, replace the propeller shaft assembly.
- Check the bearings for noise and damage. Repair or replace the bearings as necessary.

PROPELLER SHAFT VIBRATION

If a vibration is present at high speed, inspect the propeller shaft runout first.

1. Measure the runout of the propeller shaft tube at several points by rotating the final drive companion flange with your hands. For measuring point, refer to [PR-3, "Propeller Shaft Runout Measuring Point"](#).

Propeller shaft runout limit : 0.6 mm (0.024 in) or less

2. If the runout exceeds specifications, disconnect the propeller shaft at the final drive companion flange; then rotate the companion flange 90°, 180° and 270° and reconnect the propeller shaft.
3. Check the runout again. If the runout still exceeds specifications, replace the propeller shaft assembly.
4. After installation, check for vibration by driving the vehicle.

Propeller Shaft Runout Measuring Point

- Propeller shaft runout measuring point.

Propeller shaft runout measuring range

Dimension A : 160mm (6.30 in)

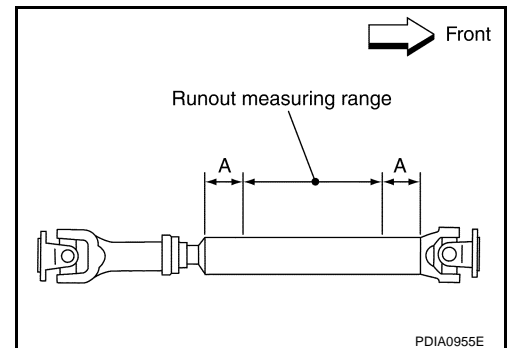
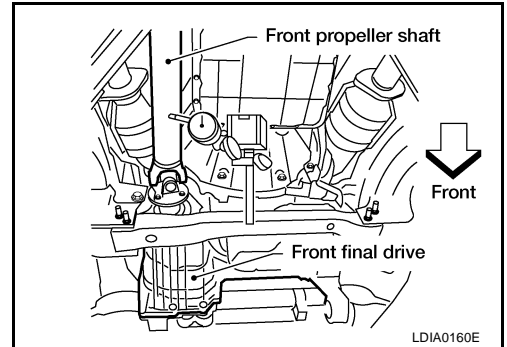

FRONT PROPELLER SHAFT

GDS0001N

Removal and Installation COMPONENTS

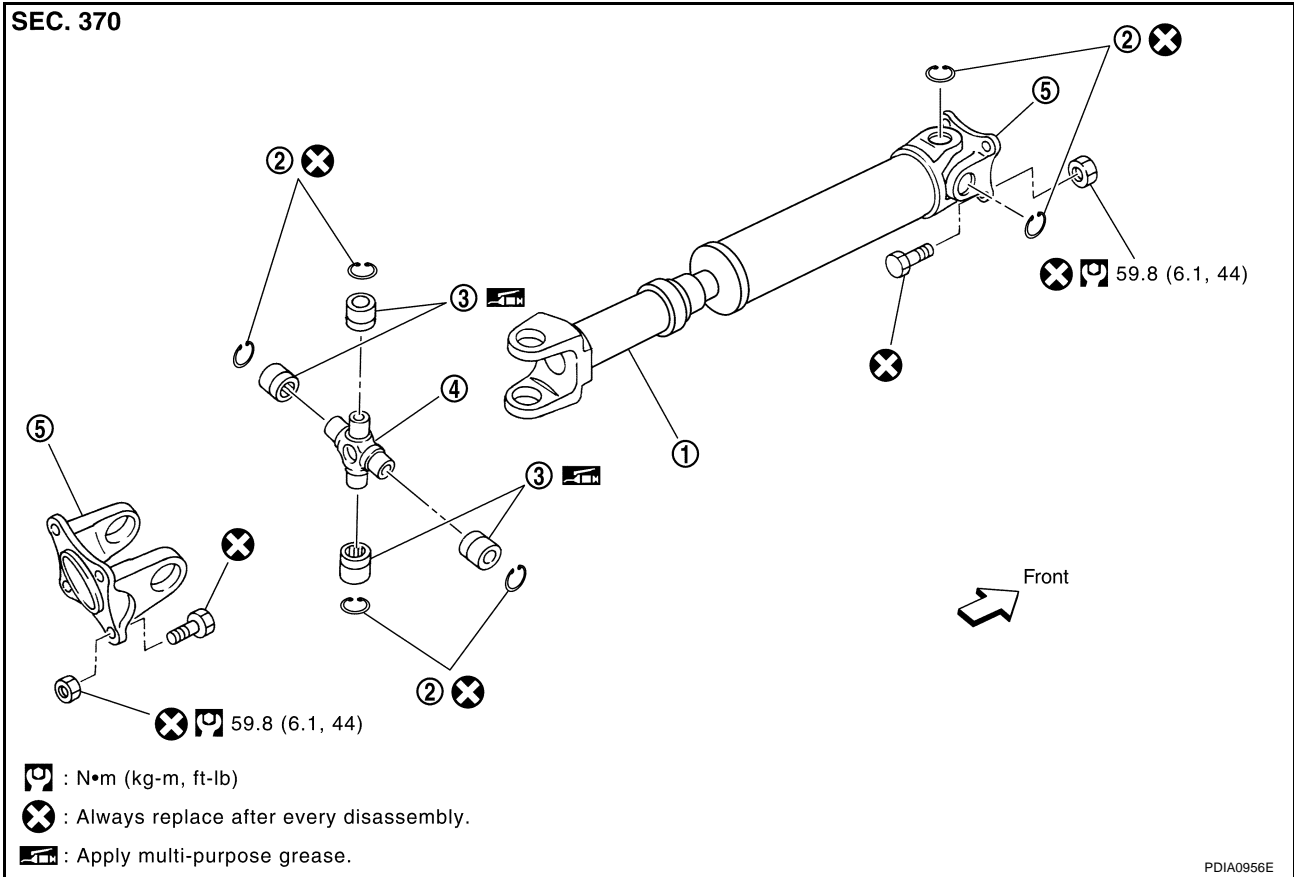

PDIA0956E

- | | | |
|-------------------------|----------------|--------------------|
| 1. Propeller shaft tube | 2. Snap ring | 3. Journal bearing |
| 4. Journal | 5. Flange yoke | |

REMOVAL

- Put matching marks on the front propeller shaft flange yoke and the front final drive companion flange as shown.

CAUTION:

For matching marks, use paint. Never damage the flange yoke and companion flange of the front final drive.

- Put matching marks on the front propeller shaft flange yoke and the transfer companion flange.

CAUTION:

For matching marks, use paint. Never damage the flange yoke and companion flange of the transfer.

- Remove the bolts and nuts, then remove the front propeller shaft from the front final drive and transfer.

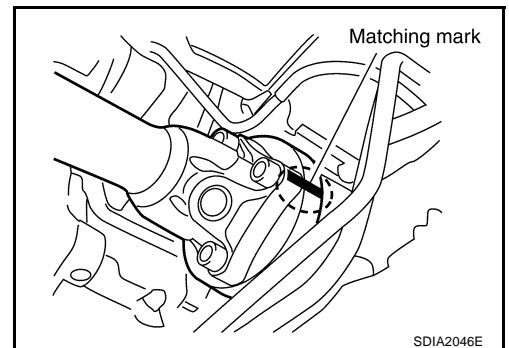

INSPECTION

- Inspect the propeller shaft runout. If runout exceeds the limit, replace the propeller shaft assembly. For measuring point, refer to [PR-3, "Propeller Shaft Runout Measuring Point"](#).

Runout limit : 0.6 mm (0.024 in) or less

FRONT PROPELLER SHAFT

- While holding the flange yoke on one side, check axial play of the joint as shown. If the journal axial play exceeds the specification, repair or replace the journal parts.

Journal axial play : 0.02 mm (0.0008 in) or less

- Check the propeller shaft tube surface for dents or cracks. If damage is detected, replace the propeller shaft assembly.

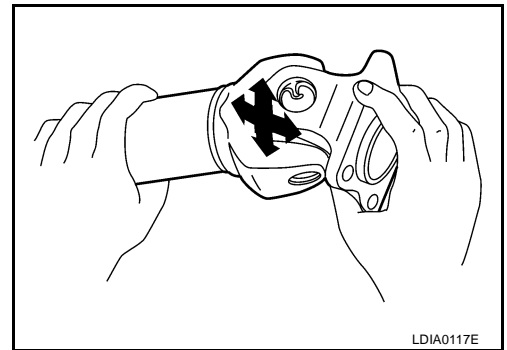

A
B
C

PR

INSTALLATION

Installation is in the reverse order of removal.

- After installation, check for vibration by driving the vehicle. Refer to [PR-2, "NVH Troubleshooting Chart"](#).

CAUTION:

Do not reuse the bolts and nuts. Always install new ones.

Disassembly and Assembly

DISASSEMBLY

1. Put matching marks on the front propeller shaft and flange yoke as shown.

CAUTION:

For matching marks, use paint. Never damage the front propeller shaft or flange yoke.

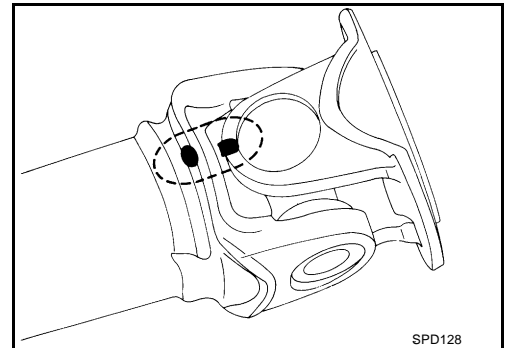

GDS00010

F

G

H

I

J

2. Remove the snap rings.

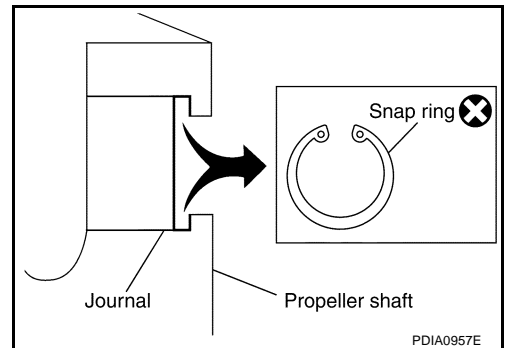

K

L

M

3. Push out and remove the journal bearings by lightly tapping the flange yoke with a hammer, taking care not to damage the journal or flange yoke hole.

NOTE:

Put marks on the disassembled parts so that they can be reinstalled in their original positions from which they were removed.

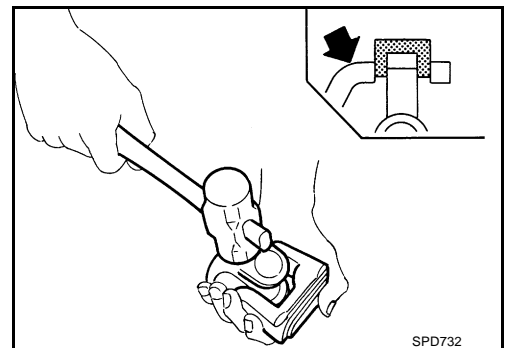

FRONT PROPELLER SHAFT

4. Push out and remove the remaining journal bearings at the opposite side by lightly tapping the flange yoke with a hammer, taking care not to damage the journal or flange yoke hole.

NOTE:

Put marks on the disassembled parts so that they can be reinstalled in their original positions from which they were removed.

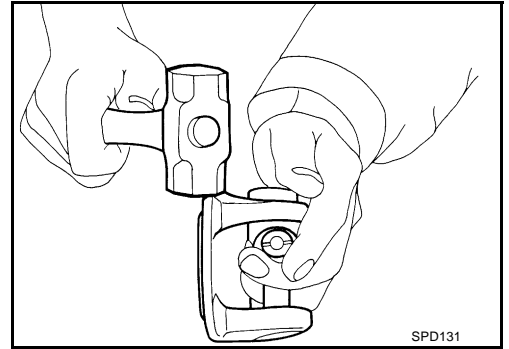

ASSEMBLY

1. Assemble the journal bearings. Apply multipurpose grease on the bearing inner surface.

NOTE:

During assembly, use caution so that the needle bearings do not fall down.

2. Select snap rings that will provide the specified play in an axial direction of the journal, and install them. Refer to [PR-12, "Snap Ring"](#).

NOTE:

Select snap rings with a difference in thickness at both sides within 0.02 mm (0.0008 in).

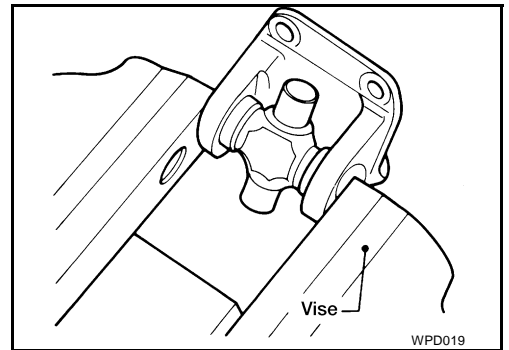

3. Adjust the thrust clearance between the bearing and snap ring to zero by tapping the yoke.

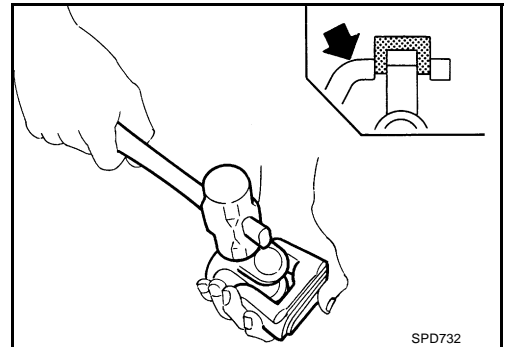

4. Make sure that the journal moves smoothly and is below the joint flex effort specification.

Joint flex effort : 1.96 N-m (0.20 kg-m, 17 in-lb) or less

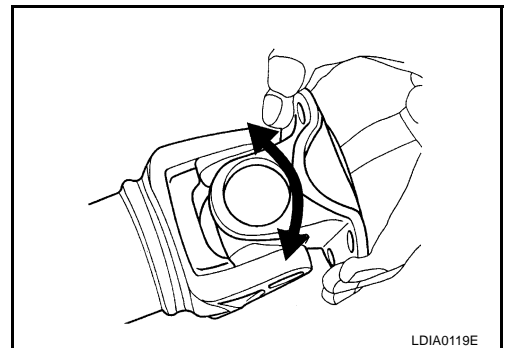

REAR PROPELLER SHAFT

REAR PROPELLER SHAFT

PFP:37000

On-Vehicle Service

GDS0001P

APPEARANCE AND NOISE INSPECTION

- Check the propeller shaft tube surface for dents or cracks. If damaged, replace the propeller shaft assembly.
- Check the bearings for noise and damage. Repair or replace the bearings as necessary.

PROPELLER SHAFT VIBRATION

If a vibration is present at high speed, inspect the propeller shaft runout first.

1. Measure the runout of the propeller shaft tube at several points by rotating the final drive companion flange with your hands. For measuring point, refer to [PR-7, "Propeller Shaft Runout Measuring Point"](#).

Propeller shaft runout limit

2WD : 0.6 mm (0.024 in) or less

4WD : 1.02 mm (0.0402 in) or less

2. If the runout exceeds specifications, disconnect the propeller shaft at the final drive companion flange; then rotate the companion flange 90°, 180° and 270° and reconnect the propeller shaft.
3. Check the runout again. If the runout still exceeds specifications, replace the propeller shaft assembly.
4. After installation, check for vibration by driving vehicle.

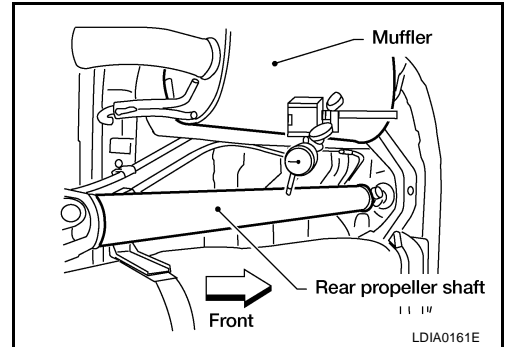

Propeller Shaft Runout Measuring Point

- **2WD**

Propeller shaft runout measuring range

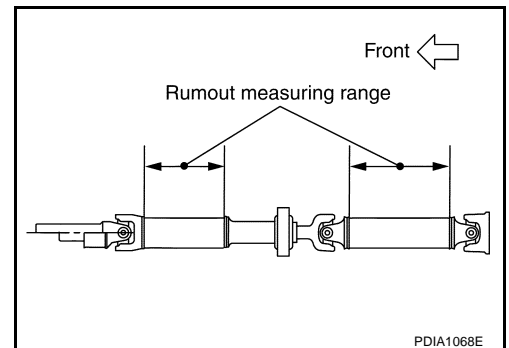

- **4WD**

Propeller shaft runout measuring range

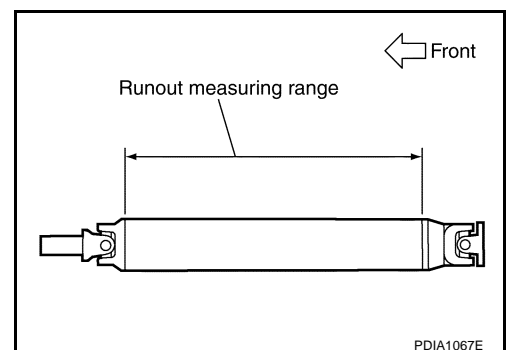

REAR PROPELLER SHAFT

GDS0001Q

Removal and Installation COMPONENTS (2WD)

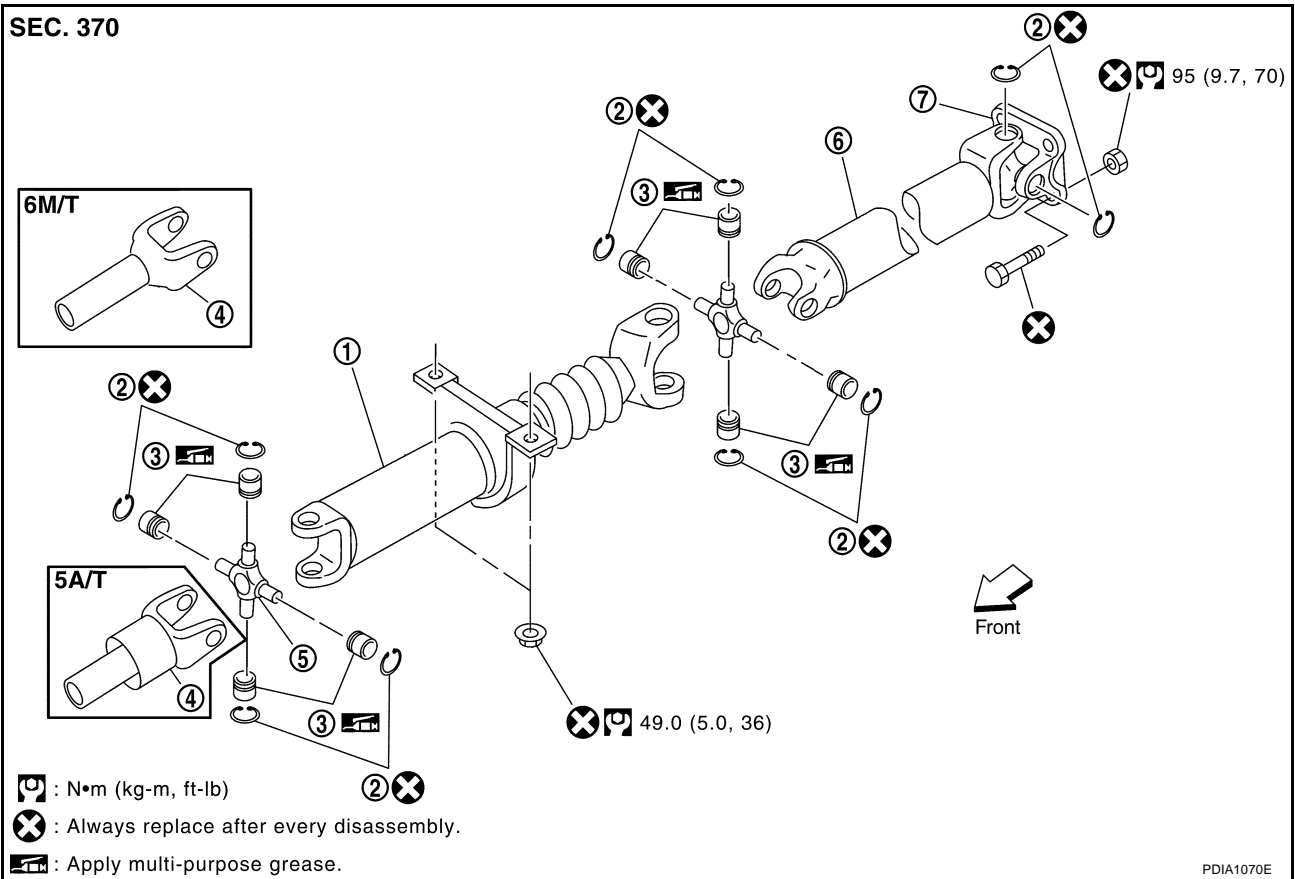

PDIA1070E

- | | | |
|--------------------------------|--------------|--------------------------------|
| 1. Propeller shaft (1st shaft) | 2. Snap ring | 3. Journal bearing |
| 4. Sleeve yoke | 5. Journal | 6. Propeller shaft (2nd shaft) |
| 7. Flange yoke | | |

COMPONENTS (4WD)

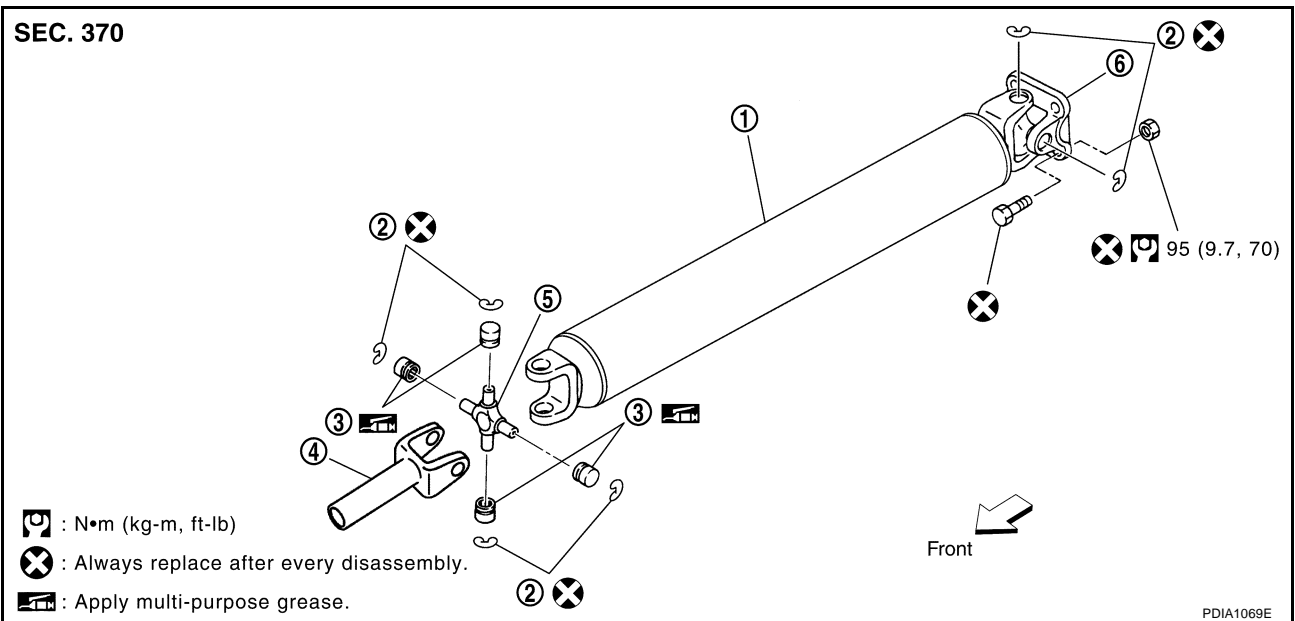

PDIA1069E

- | | | |
|-------------------------|--------------|--------------------|
| 1. Propeller shaft tube | 2. Snap ring | 3. Journal bearing |
| 4. Sleeve yoke | 5. Journal | 6. Flange yoke |

REAR PROPELLER SHAFT

REMOVAL

1. Move the A/T select lever to the N position or set M/T shift lever to neutral position.
2. Release the parking brake.
3. Put matching marks on the rear propeller shaft flange yoke and the rear final drive companion flange as shown.

CAUTION:

For matching marks, use paint. Never damage the rear propeller shaft flange yoke or the companion flange.

4. Remove the bolts and nuts, then remove the propeller shaft from the rear final drive and A/T, M/T or transfer.

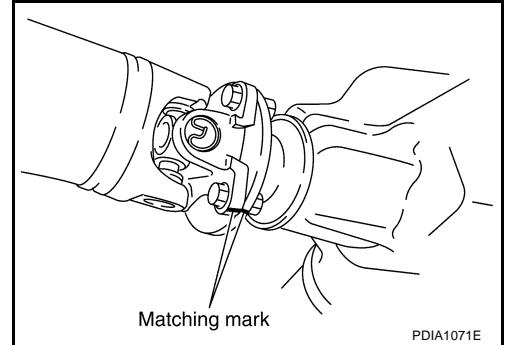

INSPECTION

- Inspect the propeller shaft runout. If runout exceeds the limit, replace the propeller shaft assembly. For measuring point, refer to [PR-7, "Propeller Shaft Runout Measuring Point"](#).

Propeller shaft runout limit

2WD : 0.6 mm (0.024 in) or less

4WD : 1.02 mm (0.0402 in) or less

- While holding the flange yoke on one side, check axial play of the joint as shown. If the journal axial play exceeds the specification, repair or replace the journal parts.

Journal axial play : 0.02 mm (0.0008 in) or less

- Check the propeller shaft tube for dents or cracks. If damage is detected, replace the propeller shaft assembly.

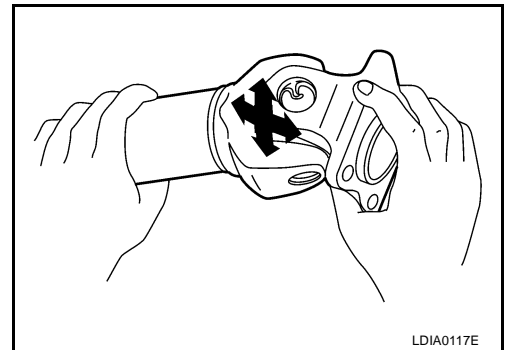

A
B
C
PR
E
F
G
H
I
J
K
L
M

REAR PROPELLER SHAFT

INSTALLATION

Installation is in the reverse order of removal.

- After installation, check for vibration by driving the vehicle. Refer to [PR-2, "NVH Troubleshooting Chart"](#).

CAUTION:

Do not reuse the bolts and nuts. Always install new ones.

Disassembly and Assembly

DISASSEMBLY

GDS0001R

1. Put matching marks on the rear propeller shaft and flange yoke as shown.

CAUTION:

For matching marks use paint. Never damage the rear propeller shaft or flange yoke.

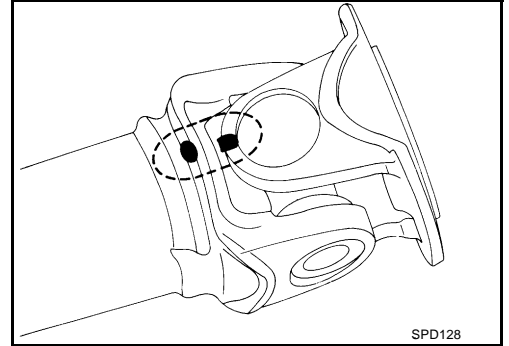

2. Remove the snap rings.

- 2WD

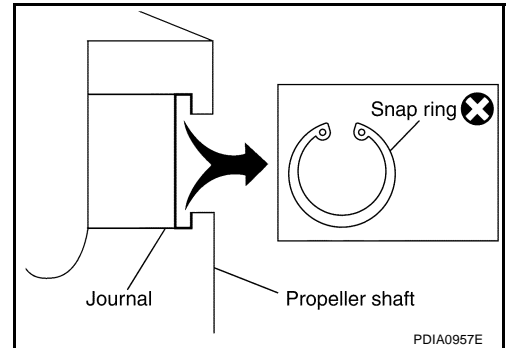

- 4WD

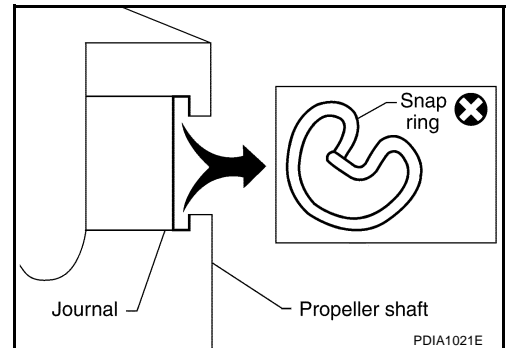

3. Push out and remove the journal bearings by lightly tapping the flange yoke with a hammer, taking care not to damage the journal or flange yoke hole.

NOTE:

Put marks on the disassembled parts so that they can be reinstalled in their original positions from which they were removed.

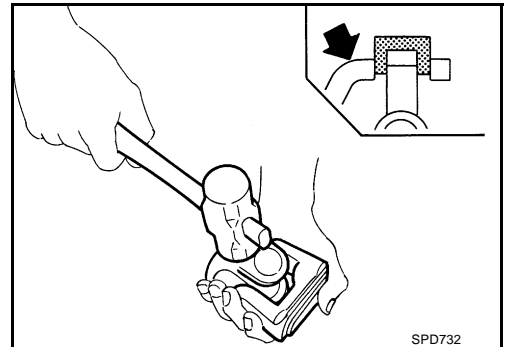

REAR PROPELLER SHAFT

4. Push out and remove the remaining journal bearings at the opposite side by lightly tapping the flange yoke with a hammer, taking care not to damage the journal or flange yoke hole.

NOTE:

Put marks on the disassembled parts so that they can be reinstalled in their original positions from which they were removed.

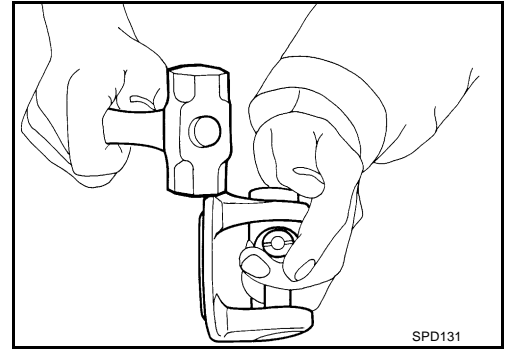

A
B
C

PR

ASSEMBLY

1. Assemble the journal bearings. Apply multipurpose grease on the bearing inner surface.

NOTE:

During assembly, use caution so that the needle bearings do not fall down.

2. Select snap rings that will provide the specified play in an axial direction of the journal, and install them. Refer to [PR-12. "Snap Ring"](#).

NOTE:

Select snap rings with a difference in thickness at both sides within 0.02 mm (0.0008 in).

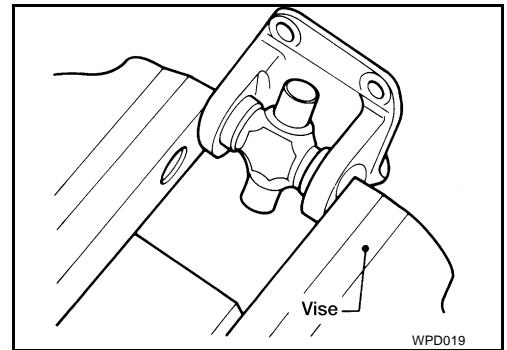

E
F
G

H

3. Adjust the thrust clearance between the bearing and snap ring to zero by tapping the yoke.

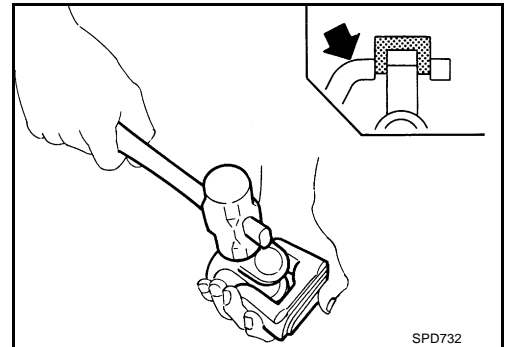

I
J
K

4. Make sure that the journal moves smoothly and is below the joint flex effort specification.

Joint flex effort

2WD : 1.96 N-m (0.20 kg-m, 17 in-lb) or less

4WD : 2.26 N-m (0.23 kg-m, 20 in-lb) or less

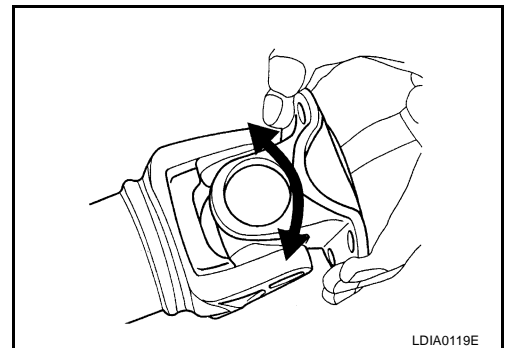

L
M

SERVICE DATA AND SPECIFICATIONS (SDS)

SERVICE DATA AND SPECIFICATIONS (SDS)

PFP:00030

General Specifications 2WD Models

GDS0001S

Applied model	VQ40DE, YD25DDTi	
	6M/T	5A/T
Propeller shaft model	3S S1310	
Number of joints	3	
Coupling method with rear final drive	Flange type	
Coupling method with transmission	Sleeve type	
1st Shaft length (Center bearing to spider)	675 mm (26.57 in)	742 mm (29.21 in)
2nd Shaft length (Spider to spider)	897 mm (35.31 in)	
Shaft outer diameter	75.64 mm (2.9779 in)	
Journal axial play	0.02 mm (0.0008 in) or less	
Propeller shaft run out limit	0.6 mm (0.024 in) or less	
Propeller shaft joint flex effort	1.96 N·m (0.20 kg·m, 17 in·lb) or less	

4WD Models

Applied model	VQ40DE, YD25DDTi	
	Front	Rear
Propeller shaft model	2F S1300	2S1330 (aluminum tube)
Number of joints	2	
Coupling method with front final drive	Flange type	
Coupling method with transfer	Flange type	Sleeve type
Shaft length (Spider to spider)	718 mm (28.27 in)	1266.8 mm (35.51 in)
Shaft outer diameter	65 mm (2.56 in)	102.5 mm (2.97 in)
Journal axial play	0.02 mm (0.0008 in) or less	
Propeller shaft run out limit	0.6 mm (0.024 in) or less	1.02 mm (0.0402 in) or less
Propeller shaft joint flex effort	1.96 N·m (0.20 kg·m, 17 in·lb) or less	2.26 N·m (0.23 kg·m, 20 in·lb) or less

Snap Ring Model 2S1330

GDS0001T

Unit: mm (in)

Thickness	Part number*	Thickness	Part number*
1.600 - 1.638 (0.0630 - 0.0645)	37146-7S000	1.524 - 1.562 (0.0600 - 0.0615)	37148-7S000
1.549 - 1.588 (0.0610 - 0.0625)	37147-7S000	1.499 - 1.537 (0.0590 - 0.0605)	37149-7S000

*Always check with the Parts Department for the latest parts information.

Model 2F S1300 and 3S S1310

Unit: mm (in)

Thickness	Part number*	Thickness	Part number*
1.45 (0.0571)	37146 7F000	1.65 (0.0650)	37150 7F000
1.50 (0.0591)	37147 7F000	1.70 (0.0669)	37151 7F000
1.55 (0.0610)	37148 7F000	1.75 (0.0689)	37152 7F000
1.60 (0.0630)	37149 7F000		

*Always check with the Parts Department for the latest parts information.