

SECTION **CL**  
CLUTCH

A  
B  
C

CL

CONTENTS

E

**SYMPTOM DIAGNOSIS** ..... 3

**NOISE, VIBRATION AND HARSHNESS (NVH) TROUBLESHOOTING** ..... 3  
 NVH Troubleshooting Chart .....3

**PRECAUTION** ..... 4

**PRECAUTIONS** ..... 4  
 Precaution for Supplemental Restraint System (SRS) "AIR BAG" and "SEAT BELT PRE-TENSIONER" .....4  
 Precaution for Procedure without Cowl Top Cover....4  
 Service Notice or Precautions .....4

**PREPARATION** ..... 5

**PREPARATION** ..... 5  
 Special Service Tool .....5  
 Commercial Service Tool .....5

**ON-VEHICLE MAINTENANCE** ..... 7

**CLUTCH PEDAL** ..... 7  
 On-Vehicle Inspection and Adjustment .....7

**CLUTCH FLUID** ..... 8  
 Bleeding .....8

**ON-VEHICLE REPAIR** ..... 9

**CLUTCH PEDAL** ..... 9  
 Exploded View .....9  
 Removal and Installation .....9  
 Inspection .....9

**CLUTCH MASTER CYLINDER** .....10  
 Exploded View .....10  
 Removal and Installation .....10  
 Disassembly and Assembly .....11  
 Inspection .....11

**OPERATING CYLINDER** .....12

Exploded View .....12  
 Removal and Installation .....12  
 Disassembly and Assembly .....12  
 Inspection .....13

**CLUTCH PIPING** .....14  
 Exploded View .....14  
 Removal and Installation .....14

**REMOVAL AND INSTALLATION** .....15

**CLUTCH RELEASE MECHANISM** .....15

**5M/T** .....15  
 5M/T : Exploded View .....15  
 5M/T : Removal and Installation .....15  
 5M/T : Inspection .....16

**6M/T** .....16  
 6M/T : Exploded View .....17  
 6M/T : Removal and Installation .....17  
 6M/T : Inspection .....18

**CLUTCH DISC, CLUTCH COVER** .....20

**5M/T** .....20  
 5M/T : Exploded View .....20  
 5M/T : Removal and Installation .....20  
 5M/T : Inspection and Adjustment .....21

**6M/T** .....22  
 6M/T : Exploded View .....22  
 6M/T : Removal and Installation .....22  
 6M/T : Inspection and Adjustment .....23

**SERVICE DATA AND SPECIFICATIONS (SDS)** .....25

**SERVICE DATA AND SPECIFICATIONS (SDS)** .....25  
 Clutch Control System .....25  
 Clutch Master Cylinder .....25  
 Clutch Operating Cylinder .....25

F  
G  
H  
I  
J  
K  
L  
M  
N  
O  
P

---

Clutch Disc .....	25	Clutch Pedal .....	25
Clutch Cover .....	25		

# NOISE, VIBRATION AND HARSHNESS (NVH) TROUBLESHOOTING

< SYMPTOM DIAGNOSIS >

## SYMPTOM DIAGNOSIS

### NOISE, VIBRATION AND HARSHNESS (NVH) TROUBLESHOOTING

#### NVH Troubleshooting Chart

INFOID:000000003297069

Use the chart below to help you find the cause of the symptom. The numbers indicate the order of the inspection. If necessary, repair or replace these parts.

#### CLUTCH

Symptom		SUSPECTED PARTS (Possible cause)																		
		CLUTCH PEDAL (Free play out of adjustment)	CLUTCH LINE (Air in line)	MASTER CYLINDER PISTON CUP (Damaged)	OPERATING CYLINDER PISTON CUP (Damaged)	ENGINE MOUNTING (Loose)	RELEASE BEARING (Worn, dirty or damaged)	CLUTCH DISC (Out of true)	CLUTCH DISC (Runout is excessive)	CLUTCH DISC (Lining broken)	CLUTCH DISC (Dirty or burned)	CLUTCH DISC (Oily)	CLUTCH DISC (Worn out)	CLUTCH DISC (Hardened)	CLUTCH DISC (Lack of spline grease)	DIAPHRAGM SPRING (Damaged)	DIAPHRAGM SPRING (Out of tip alignment)	PRESSURE PLATE (Distortion)	FLYWHEEL (Distortion)	
Symptom	Clutch grabs/chatters					1						2								
	Clutch pedal spongy		1	2	2															
	Clutch noisy						1													
	Clutch slips	1										2	2			3		4	5	
	Clutch does not disengage	1	2	3	4				5	5	5	5			5	6	6	7		
Reference page		CL-7	CL-8	CL-10	CL-12	EM-73 (QR25DE), EM-214 (VQ40DE)	CL-15 (5M/T), CL-17 (6 M/T)					CL-20 (5M/T), CL-22 (6M/T)							EM-86 (QR25DE), EM-229 (VQ40DE)	

# PRECAUTIONS

< PRECAUTION >

## PRECAUTION

### PRECAUTIONS

#### Precaution for Supplemental Restraint System (SRS) "AIR BAG" and "SEAT BELT PRE-TENSIONER"

INFOID:000000003297070

The Supplemental Restraint System such as "AIR BAG" and "SEAT BELT PRE-TENSIONER", used along with a front seat belt, helps to reduce the risk or severity of injury to the driver and front passenger for certain types of collision. This system includes seat belt switch inputs and dual stage front air bag modules. The SRS system uses the seat belt switches to determine the front air bag deployment, and may only deploy one front air bag, depending on the severity of a collision and whether the front occupants are belted or unbelted. Information necessary to service the system safely is included in the SR and SB section of this Service Manual.

#### **WARNING:**

- To avoid rendering the SRS inoperative, which could increase the risk of personal injury or death in the event of a collision which would result in air bag inflation, all maintenance must be performed by an authorized NISSAN/INFINITI dealer.
- Improper maintenance, including incorrect removal and installation of the SRS, can lead to personal injury caused by unintentional activation of the system. For removal of Spiral Cable and Air Bag Module, see the SR section.
- Do not use electrical test equipment on any circuit related to the SRS unless instructed to in this Service Manual. SRS wiring harnesses can be identified by yellow and/or orange harnesses or harness connectors.

#### Precaution for Procedure without Cowl Top Cover

INFOID:000000003297071

When performing the procedure after removing cowl top cover, cover the lower end of windshield with urethane, etc.

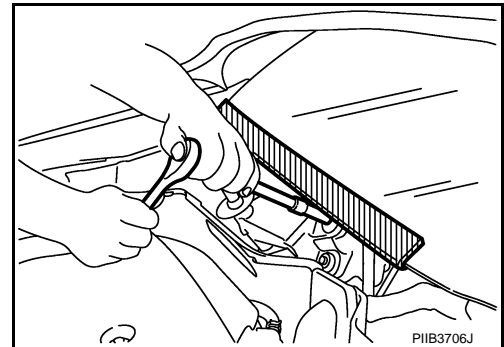

#### Service Notice or Precautions

INFOID:000000003297072

- Always use recommended fluid. Refer to [MA-12, "Fluids and Lubricants"](#).
- Never reuse drained fluid.
- Be careful not to splash fluid on painted areas.
- When removing and installing clutch piping, use tool.
- Use new fluid to clean or wash all parts of master cylinder.
- Never use mineral oils such as gasoline or kerosene. It will ruin the rubber parts of the hydraulic system.

#### **WARNING:**

After cleaning clutch disc, wipe it with a dust collector. Do not use compressed air.

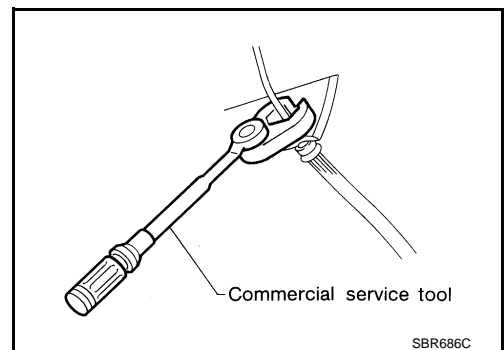

# PREPARATION

< PREPARATION >

## PREPARATION

### PREPARATION

#### Special Service Tool

INFOID:000000003297073

The actual shapes of Kent-Moore tools may differ from those of special service tools illustrated here.

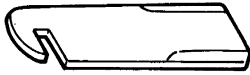
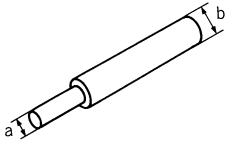
Tool number (Kent-Moore No.) Tool name	Description
ST20050240 ( — ) Diaphragm adjusting wrench  ZZA0508D	Adjusting unevenness of diaphragm spring of clutch cover
ST20630000 (J-26366) Clutch aligning bar  ZZA1178D	Installing clutch disc <b>a: 15.8 mm (0.622 in) dia.</b> <b>b: 22.9 mm (0.902 in) dia.</b>

#### Commercial Service Tool

INFOID:000000003297074

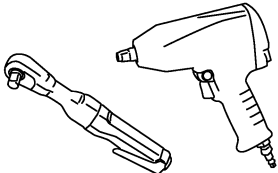
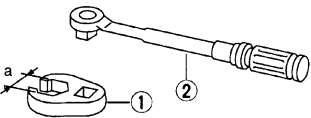
Tool name	Description
Pin punch  ZZA0515D	Removing and installing master cylinder spring pin <b>Tip diameter: 4.5 mm (0.177 in) dia.</b>
Power tool  PBIC0190E	Loosening bolts and nuts
1. Flare nut crowfoot 2. Torque wrench  S-NT360	Removing and installing clutch piping <b>a: 10 mm (0.39 in)</b>

# PREPARATION

## < PREPARATION >

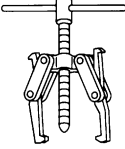
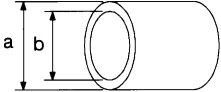
Tool name	Description
<p data-bbox="164 199 305 226">Bearing puller</p>  <p data-bbox="850 415 894 432">NT077</p>	<p data-bbox="1013 199 1276 226">Removing release bearing</p>
<p data-bbox="164 451 289 478">Bearing drift</p>  <p data-bbox="850 667 894 684">NT474</p>	<p data-bbox="1013 451 1263 478">Installing release bearing</p> <p data-bbox="1013 478 1247 506"><b>a: 52 mm (2.05 in) dia.</b></p> <p data-bbox="1013 506 1247 533"><b>b: 45 mm (1.77 in) dia.</b></p>

# CLUTCH PEDAL

< ON-VEHICLE MAINTENANCE >

## ON-VEHICLE MAINTENANCE

### CLUTCH PEDAL

#### On-Vehicle Inspection and Adjustment

INFOID:000000003297075

1. Check to see if the clevis pin floats freely in the bore of the clutch pedal. It should not be bound by the clevis or clutch pedal.
  - a. If the clevis pin is not free, check that the pedal stopper bolt or ASCD clutch switch is not applying pressure to the clutch pedal causing the clevis pin to bind. To adjust, loosen the lock nut and turn the pedal stopper bolt or ASCD clutch switch.
  - b. Tighten the lock nut to the specified torque. Refer to [CL-9, "Exploded View"](#).
  - c. Verify that the clevis pin floats in the bore of the clutch pedal. It should not be bound by the clutch pedal.
  - d. If the clevis pin is still not free, remove the clevis pin and check for deformation or damage. Replace clevis pin if necessary. Leave pin removed for step 2.
2. Check clutch pedal stroke for free range of movement.
  - a. With the clevis pin removed, manually move the clutch pedal up and down to determine if it moves freely.
  - b. If any sticking is noted, replace the assembly.
3. Adjust clearance "C" while depressing clutch pedal fully. (With clutch interlock switch)

**Clearance "C" : 0.1 - 1.0 mm (0.004 - 0.039 in)**

4. Check clutch hydraulic and system components (clutch master cylinder, clutch operating cylinder, clutch withdrawal lever and clutch release bearing) for sticking or binding.
  - a. If any sticking or binding noted, repair or replace related parts as necessary.
  - b. If hydraulic system repair was necessary, bleed the clutch hydraulic system. Refer to [CL-8, "Bleeding"](#).

**NOTE:**

Do not use a vacuum assist or any other type of power bleeder on this system. Use of a vacuum assist or power bleeder will not purge all the air from the system.

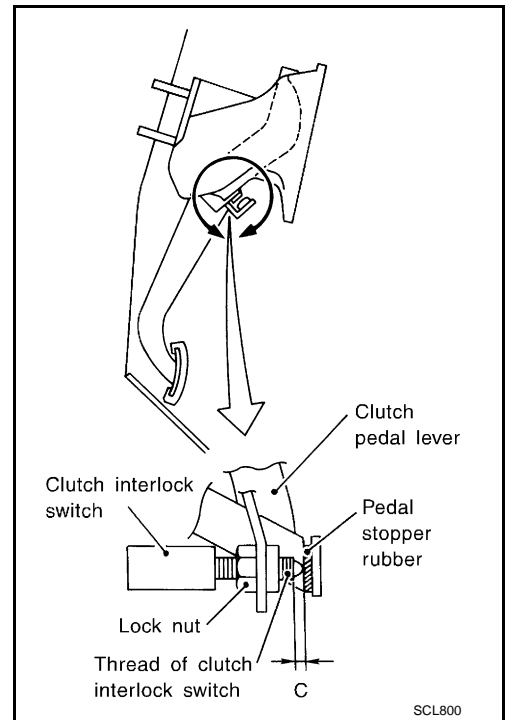
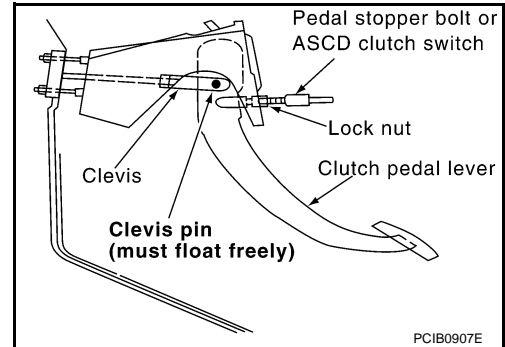

# CLUTCH FLUID

< ON-VEHICLE MAINTENANCE >

## CLUTCH FLUID

### Bleeding

INFOID:000000003297076

#### **CAUTION:**

**Do not spill clutch fluid onto painted surfaces. If it spills, wipe up immediately and wash the affected area with water.**

#### **NOTE:**

- Do not use a vacuum assist or any other type of power bleeder on this system. Use of a vacuum assist or power bleeder will not purge all the air from the system.
  - Monitor the fluid level in the reservoir tank to make sure it does not empty.
1. Top off reservoir with new recommended brake fluid. Refer to [MA-12, "Fluids and Lubricants"](#).
  2. Connect a transparent vinyl tube and container to the air bleeder valve on the clutch operating cylinder.
  3. Fully depress the clutch pedal several times.
  4. With the clutch pedal depressed, open the bleeder valve to release the air.
  5. Close the bleeder valve.
  6. Repeat steps 3 to 5 until clear brake fluid comes out of the air bleeder valve.
  7. Tighten the air bleeder to the specified torque. Refer to [CL-12, "Exploded View"](#).

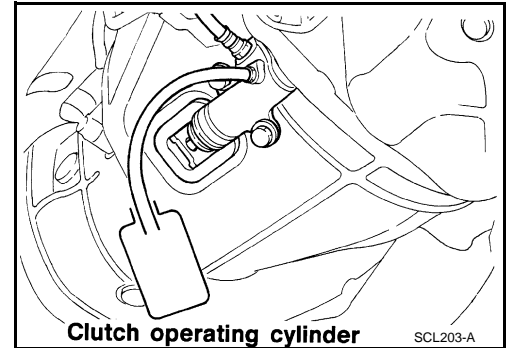



# CLUTCH PEDAL

< ON-VEHICLE REPAIR >

## ON-VEHICLE REPAIR

### CLUTCH PEDAL

#### Exploded View

INFOID:000000003297077

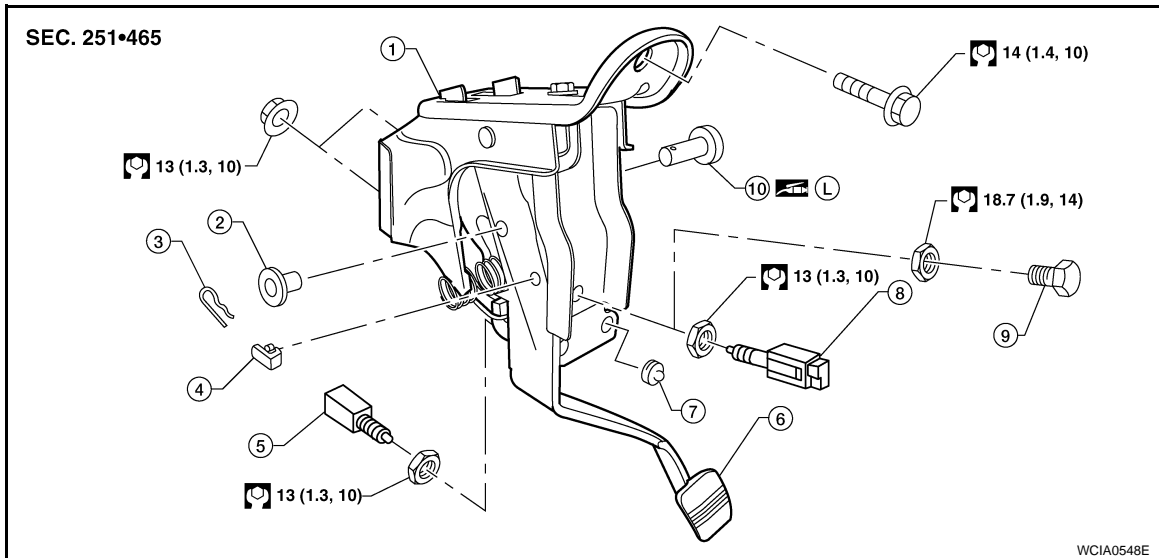

- |                         |                                    |                                      |
|-------------------------|------------------------------------|--------------------------------------|
| 1. Bracket              | 2. Bushing                         | 3. Snap pin                          |
| 4. Pedal stopper rubber | 5. Clutch interlock switch         | 6. Clutch pedal                      |
| 7. Stopper rubber       | 8. ASC D clutch switch (with ASCD) | 9. Pedal stopper bolt (without ASCD) |
| 10. Clevis pin          |                                    |                                      |

#### Removal and Installation

INFOID:000000003297078

##### REMOVAL

1. Remove the clutch pedal bracket nuts from inside the engine compartment.
2. Disconnect the clutch interlock switch and ASCD clutch switch, then remove the wiring harness from the pedal assembly.
3. Remove the snap pin and clevis pin.
4. Remove the pedal bracket bolt and then remove the clutch pedal assembly.

##### INSTALLATION

Installation is in the reverse order of removal.

##### NOTE:

Tighten the pedal stopper bolt lock nut or ASCD clutch switch lock nut to the specified torque after installing the clutch pedal assembly in the vehicle and adjusting the pedal free play.

#### Inspection

INFOID:000000003297079

##### INSPECTION AFTER REMOVAL

- Inspect the clutch pedal for bends, damage, or cracked welds. Replace if necessary.
- Make sure that the assist spring and return spring have not lost their spring. Replace if necessary.

# CLUTCH MASTER CYLINDER

< ON-VEHICLE REPAIR >

## CLUTCH MASTER CYLINDER

Exploded View

INFOID:000000003297080

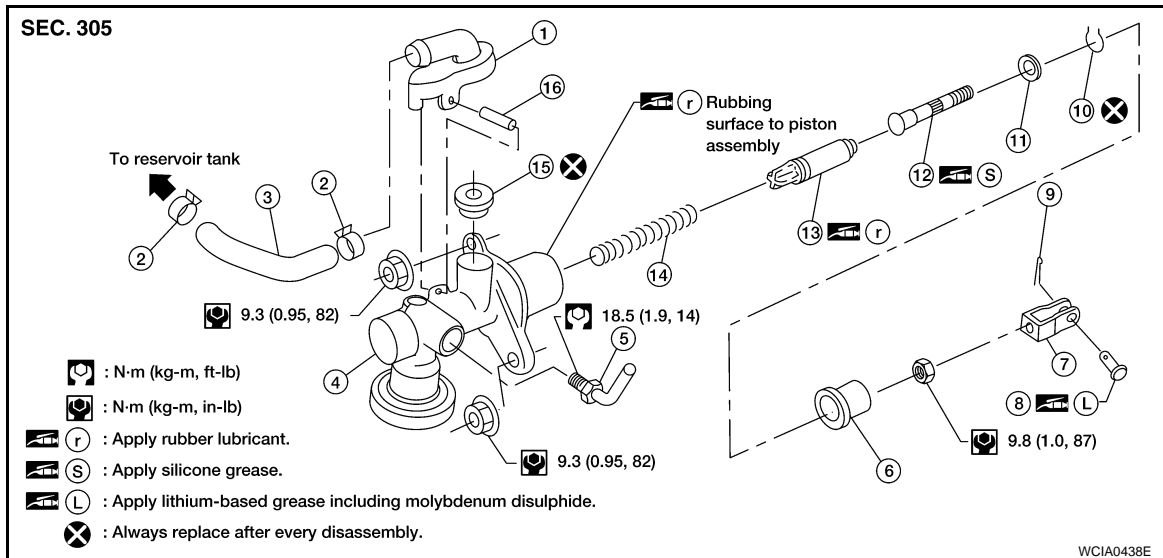

- |                     |                   |                    |
|---------------------|-------------------|--------------------|
| 1. Nipple           | 2. Clamp          | 3. Reservoir hose  |
| 4. Cylinder body    | 5. Clutch tube    | 6. Dust cover      |
| 7. Clevis           | 8. Clevis pin     | 9. Snap pin        |
| 10. Stopper ring    | 11. Stopper       | 12. Push rod       |
| 13. Piston assembly | 14. Return spring | 15. Reservoir seal |
| 16. Spring pin      |                   |                    |

## Removal and Installation

INFOID:000000003297081

### REMOVAL

1. Remove the snap pin and clevis pin from the clevis, and separate it from the clutch pedal.
2. Drain the brake fluid from the clutch hydraulic system.

#### CAUTION:

**Do not spill brake fluid onto painted surfaces. If it spills, wipe up immediately and wash the affected area with water.**

3. Remove the hose clamp and hose from the clutch master cylinder.
4. Remove the clutch tube using suitable tool.
5. Remove the clutch master cylinder nuts, and remove the clutch master cylinder from the vehicle.

### INSTALLATION

Installation is in the reverse order of removal.

- Before installation, check the position of the clevis and push rod. If "L" is outside standard length, adjust the position of the clevis and push rod.

#### Length "L"

**QR25DE : 119.5 mm (4.70 in)**

**VQ40DE : 120.5 mm (4.74 in)**

- After installation, inspect and adjust the clutch pedal as necessary, then bleed the clutch hydraulic system. Refer to [CL-7, "On-Vehicle Inspection and Adjustment"](#) and [CL-8, "Bleeding"](#).

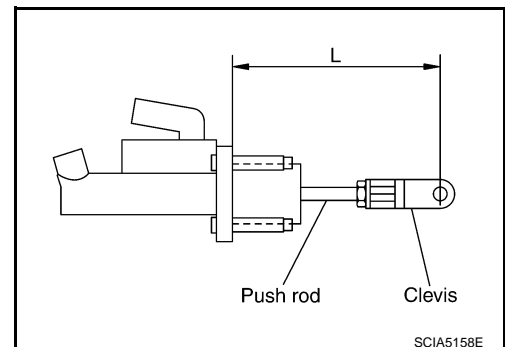

SCIA5158E

# CLUTCH MASTER CYLINDER

< ON-VEHICLE REPAIR >

## Disassembly and Assembly

INFOID:000000003297082

### DISASSEMBLY

1. Remove the spring pin, using suitable tool.
2. Remove the nipple and reservoir seal from the cylinder body.
3. Loosen the push rod lock nut then remove the clevis and lock nut, if necessary.

**NOTE:**

Clutch pedal height is controlled with the position of the clevis and push rod.

4. Remove the dust cover from the cylinder body.
5. Remove the stopper ring and stopper. Remove the push rod from the cylinder body while holding it securely to prevent the piston assembly from popping out.
6. Remove the piston assembly and return spring.

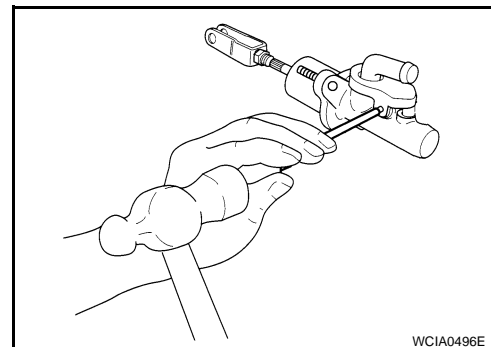

### ASSEMBLY

1. Apply rubber lubricant to the internal surface of the cylinder body, sliding surface of piston assembly, and the piston cup. Insert the return spring and piston assembly to the cylinder body.
2. Apply silicone grease to the push rod and install the stopper and stopper ring.

**CAUTION:**

**Restrain the push rod while doing this because there is a danger the piston assembly will fly out of the master cylinder.**

3. Install the dust cover to the cylinder body.
4. Install the reservoir seal and nipple to the cylinder body.
5. Install the clevis to the push rod.
6. Check and adjust the position of the clevis and push rod. After adjusting the length "L", tighten lock nut to the specified torque. Refer to [CL-10, "Exploded View"](#).

**Length "L"**

**QR25DE : 119.5 mm (4.70 in)**

**VQ40DE : 120.5 mm (4.74 in)**

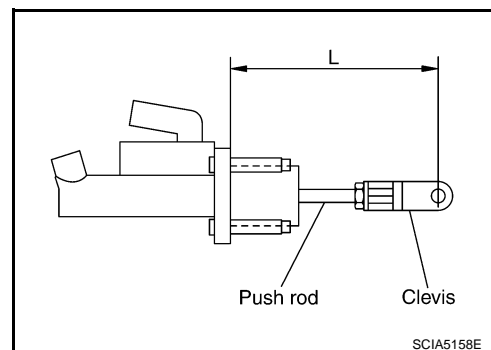

### Inspection

INFOID:000000003297083

### INSPECTION AFTER DISASSEMBLY

Inspect for the following, replace parts as necessary.

- Damage, foreign material, wear, corrosion, and pin holes on the cylinder inner surface
- Damaged or deformed nipple
- Weak spring
- Cracked or deformed dust cover

# OPERATING CYLINDER

< ON-VEHICLE REPAIR >

## OPERATING CYLINDER

### Exploded View

INFOID:000000003297084

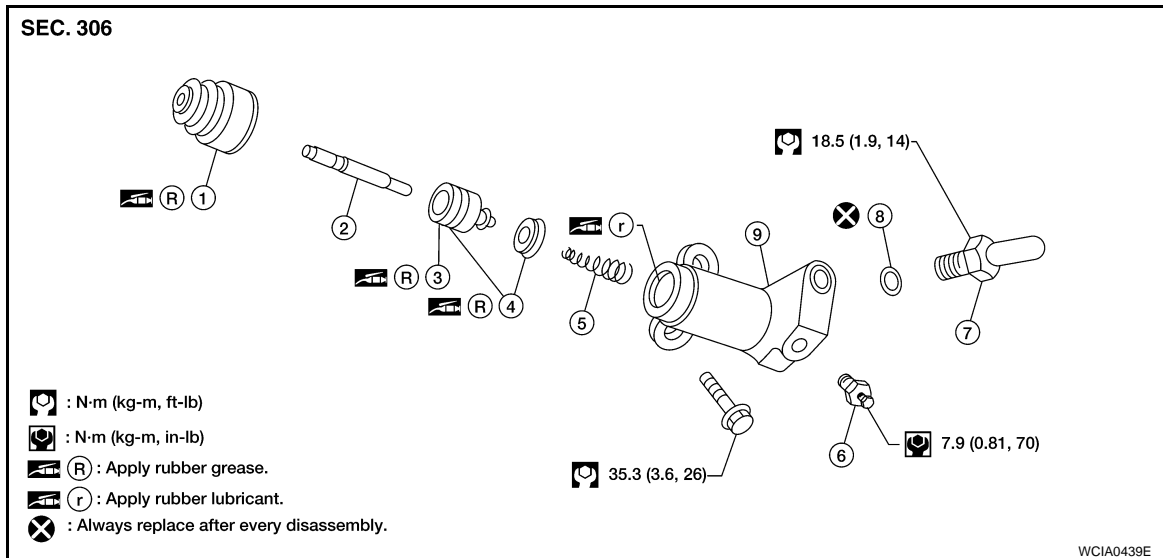

- |                |                  |                  |
|----------------|------------------|------------------|
| 1. Dust cover  | 2. Push rod      | 3. Piston        |
| 4. Piston cup  | 5. Piston spring | 6. Air bleeder   |
| 7. Clutch hose | 8. Copper washer | 9. Cylinder body |

### Removal and Installation

INFOID:000000003297085

#### REMOVAL

1. Drain the brake fluid from the clutch hydraulic system.  
**CAUTION:**  
**Do not spill brake fluid on painted surfaces. If it spills, wipe up immediately and wash the affected area with water.**
2. Remove the clutch hose and copper washer from the operating cylinder.  
**CAUTION:**  
**Do not reuse the copper washer.**
3. Remove the operating cylinder bolts, and remove the operating cylinder from the vehicle.

#### INSTALLATION

Installation is in the reverse order of removal.

- Tighten the clutch hose fitting to the specified torque. Refer to [CL-14, "Exploded View"](#).  
**CAUTION:**  
**Make sure the clutch hose is not bent or twisted.**
- After installation, bleed the clutch hydraulic system. Refer to [CL-8, "Bleeding"](#).

### Disassembly and Assembly

INFOID:000000003297086

#### DISASSEMBLY

- Remove the dust cover, push rod and piston assembly from the cylinder body.

#### ASSEMBLY

1. Apply rubber lubricant to the cylinder body inner surface and rubber grease to the piston cup and piston.
2. Insert the piston assembly and piston spring into the cylinder body.
3. Apply rubber grease to the dust cover and install the push rod and dust cover.

# OPERATING CYLINDER

< ON-VEHICLE REPAIR >

## Inspection

INFOID:000000003297087

### INSPECTION AFTER DISASSEMBLY

Inspect for the following, replace parts as necessary.

- Damage, foreign material, wear, corrosion, and pinholes on the cylinder inner surface, piston, and sliding part of piston cup
- Weak spring
- Cracked or deformed dust cover

A  
B  
C  
CL  
E  
F  
G  
H  
I  
J  
K  
L  
M  
N  
O  
P



# CLUTCH PIPING

< ON-VEHICLE REPAIR >

## CLUTCH PIPING

### Exploded View

INFOID:000000003297088

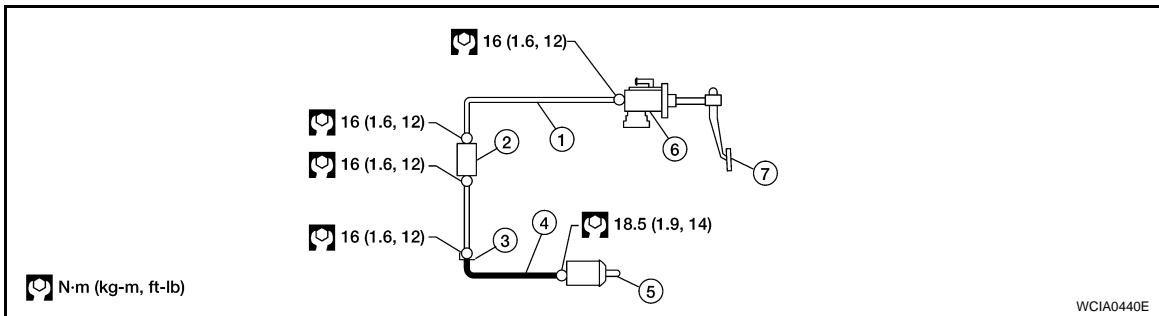

- |                 |                       |                    |
|-----------------|-----------------------|--------------------|
| 1. Clutch tube  | 2. Clutch orifice     | 3. Lock plate      |
| 4. Clutch hose  | 5. Operating Cylinder | 6. Master cylinder |
| 7. Clutch pedal |                       |                    |

### Removal and Installation

INFOID:000000003297089

Carefully observe the following during clutch tube removal and installation.

#### CAUTION:

**Do not spill brake fluid onto painted surfaces. If it spills, wipe up immediately and wash the affected area with water.**

- When installing the clutch hose to the bracket, align the clutch hose metal fittings with the bracket positioning emboss, then install the lock plate to secure.

#### CAUTION:

- Do not damage the clutch hose.
- Make sure the clutch hose is not bent or twisted.
- Tighten the clutch tube and hose fittings to the specified torque.

#### CAUTION:

- Do not reuse the copper washer.
- Do not damage the clutch tube fittings or clutch tube.
- After installation, bleed the air from the clutch hydraulic system. Refer to [CL-8, "Bleeding"](#).

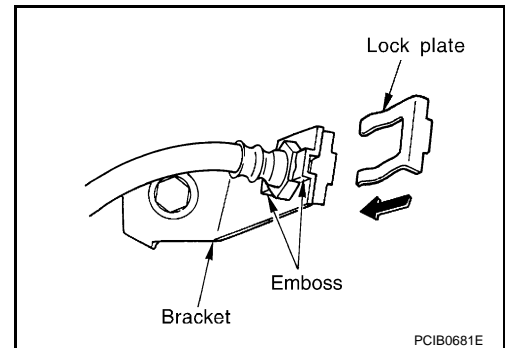

# CLUTCH RELEASE MECHANISM

< REMOVAL AND INSTALLATION >

## REMOVAL AND INSTALLATION

### CLUTCH RELEASE MECHANISM

5M/T

5M/T : Exploded View

INFOID:000000003297120

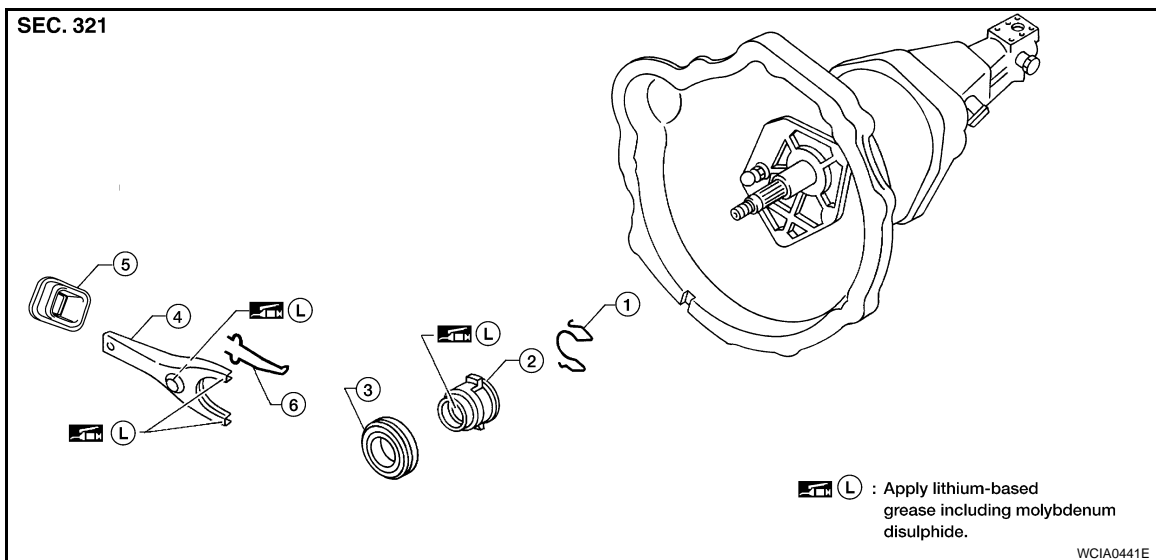

- |                     |                           |                    |
|---------------------|---------------------------|--------------------|
| 1. Holder spring    | 2. Release bearing sleeve | 3. Release bearing |
| 4. Withdrawal lever | 5. Dust cover             | 6. Retainer spring |

5M/T : Removal and Installation

INFOID:000000003297121

#### REMOVAL

1. Remove the manual transmission from the vehicle. Refer to [TM-19, "Removal and Installation from Vehicle"](#).
2. Remove the release bearing sleeve assembly, holder spring, and withdrawal lever from inside the clutch housing.
3. Remove the dust cover.
4. Remove the retainer spring from the withdrawal lever.
5. Remove the release bearing from release bearing sleeve using suitable tool.

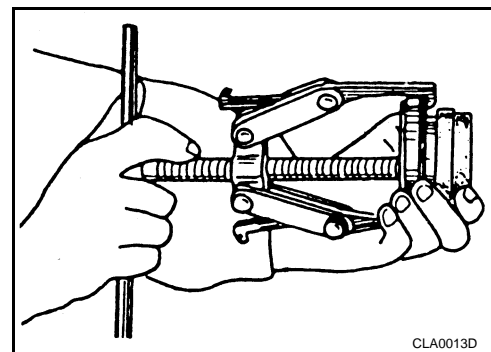

#### INSTALLATION

Installation is in the reverse order of removal.

**NOTE:**

# CLUTCH RELEASE MECHANISM

## < REMOVAL AND INSTALLATION >

- Install the release bearing to release bearing sleeve using suitable tool, as shown.

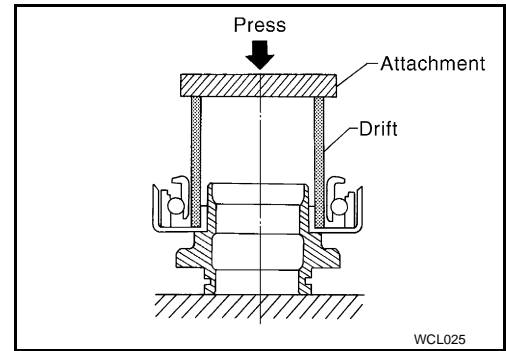

- Clean old grease and abrasive materials off the grease application areas.
- Apply grease to the specified points as shown.

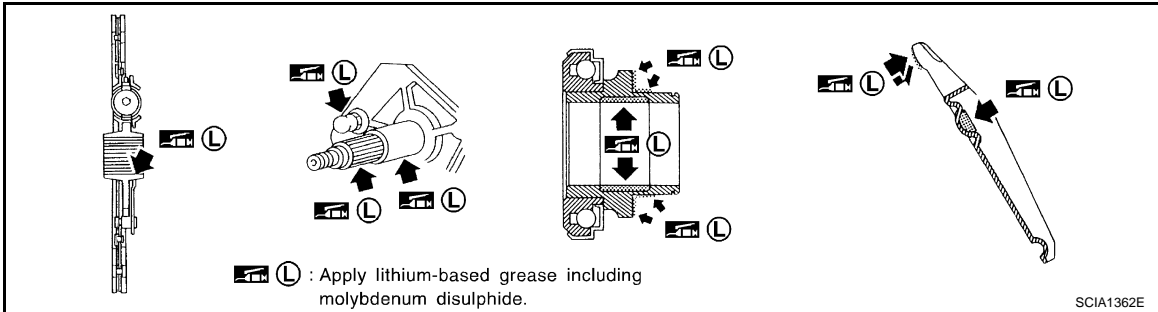

- Apply approximately 1 mm (0.04 in) thick coat of clutch sleeve grease to withdrawal lever and holder spring frictional surfaces.
- Apply a coat of clutch sleeve grease to ball pin contact surface of the withdrawal lever and inner slots of the release bearing. The grease surface should be level with the surrounding area.
- Apply a thin coat of clutch sleeve grease to the release bearing frictional surface. After grease application, install release bearing. Wipe off excess grease forced out during bearing installation.

### CAUTION:

- Be careful not to bring any grease into contact with the clutch disc facing, pressure plate surface, or flywheel surface.
- Before installing manual transmission to the vehicle, check that each sliding surface slides smoothly by operating withdrawal lever.

## 5M/T : Inspection

INFOID:000000003297122

### INSPECTION AFTER REMOVAL

- Replace the release bearing if it is seized, damaged, faulty in rotation direction, or has poor aligning function.
- Replace the withdrawal lever if its contact surface is worn abnormally.
- Replace the dust seal if it is deformed or cracked.

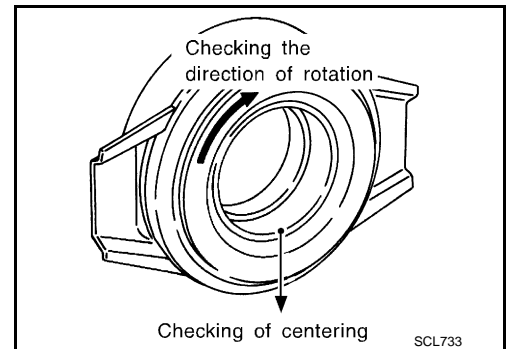

## 6M/T



# CLUTCH RELEASE MECHANISM

< REMOVAL AND INSTALLATION >

6M/T : Exploded View

INFOID:000000003297090

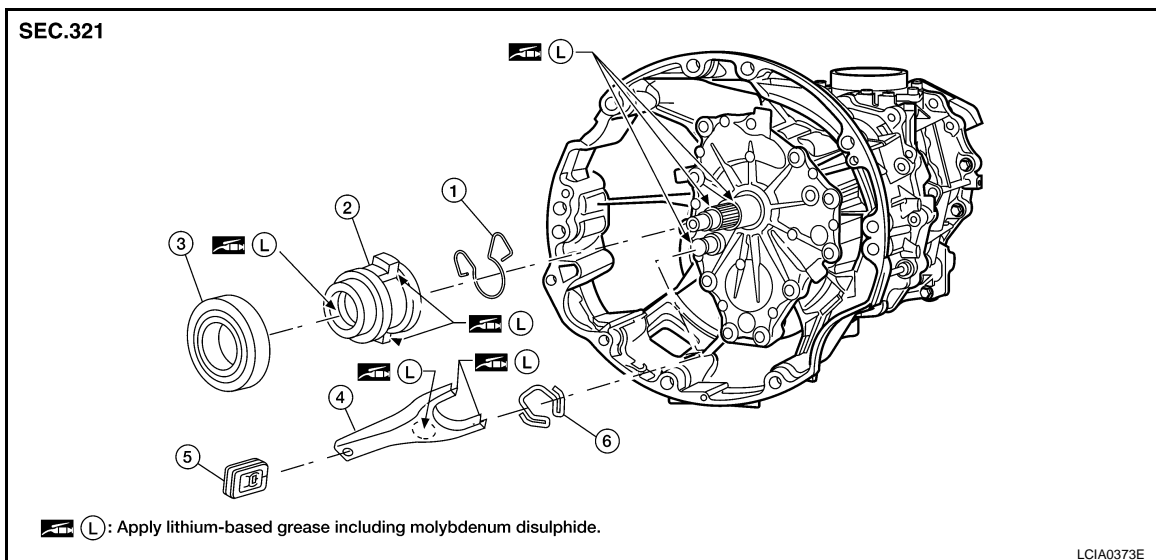

- |                     |                           |                    |
|---------------------|---------------------------|--------------------|
| 1. Holder spring    | 2. Release bearing sleeve | 3. Release bearing |
| 4. Withdrawal lever | 5. Dust cover             | 6. Snap spring     |

6M/T : Removal and Installation

INFOID:000000003297091

## REMOVAL

1. Remove the manual transmission from the vehicle. Refer to [TM-75, "Removal and Installation from Vehicle \(For 2WD Models\)"](#) or [TM-77, "Removal and Installation from Vehicle \(For 4WD Models\)"](#).
2. Remove the release bearing sleeve assembly, holder spring, and withdrawal lever from inside the clutch housing.
3. Remove the dust cover.
4. Remove the snap spring from the withdrawal lever.
5. Remove the release bearing from release bearing sleeve using suitable tool.

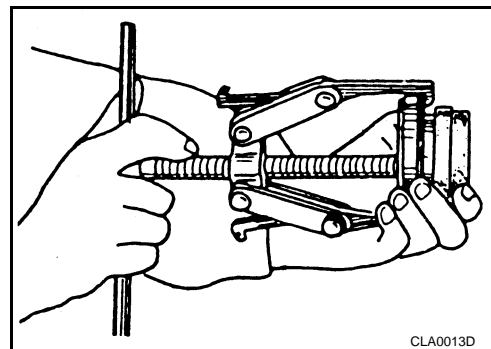

## INSTALLATION

Installation is in the reverse order of removal.

**NOTE:**

# CLUTCH RELEASE MECHANISM

## < REMOVAL AND INSTALLATION >

- Install the release bearing to release bearing sleeve using suitable tool, as shown.

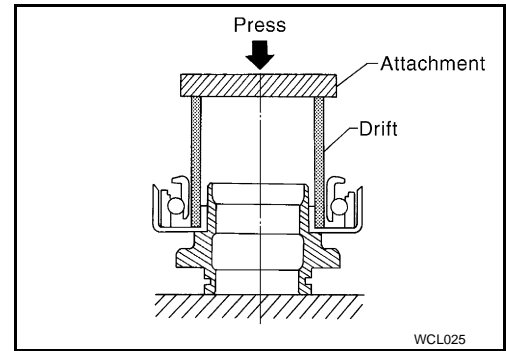

- Clean old grease and abrasive materials off the grease application areas.
- Apply grease to the specified points as shown.

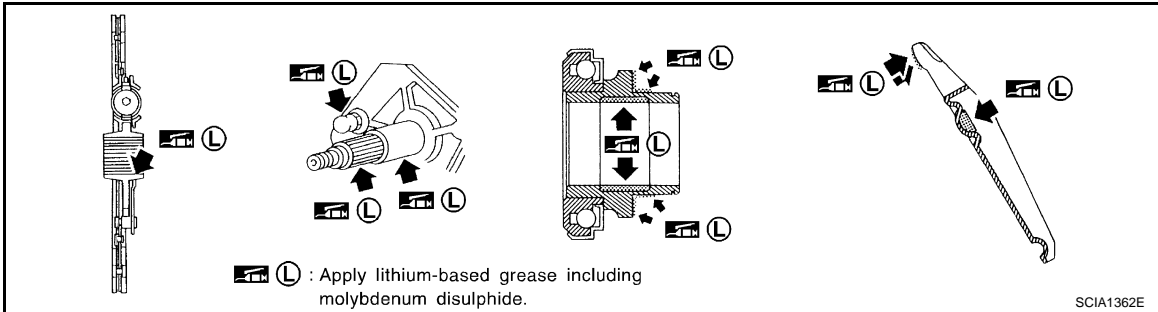

- Apply approximately 1 mm (0.04 in) thick coat of clutch sleeve grease to withdrawal lever and holder spring frictional surfaces.
- Apply a coat of clutch sleeve grease to ball pin contact surface of the withdrawal lever and inner slots of the release bearing. The grease surface should be level with the surrounding area.
- Apply a thin coat of clutch sleeve grease to the release bearing frictional surface. After grease application, install release bearing. Wipe off excess grease forced out during bearing installation.

### CAUTION:

- Before installing the manual transaxle to the vehicle, check that each sliding surface slides smoothly by operating withdrawal lever.
- Be careful not to bring any grease into contact with the clutch disc facing, pressure plate surface, or flywheel surface.
- When assembling, make sure that both ends of the snap spring touch the end face of the withdrawal lever.
- Be careful with the orientation of the installation.

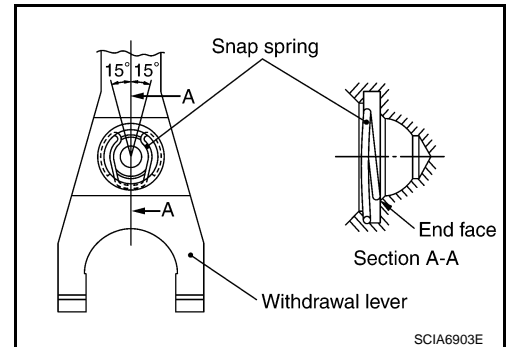

6M/T : Inspection

INFOID:000000003297092

INSPECTION AFTER REMOVAL

## CLUTCH RELEASE MECHANISM

### < REMOVAL AND INSTALLATION >

- Replace the release bearing if it is seized, damaged, faulty in rotation direction, or has poor aligning function.
- Replace the withdrawal lever if its contact surface is worn abnormally.
- Replace the dust seal if it is deformed or cracked.

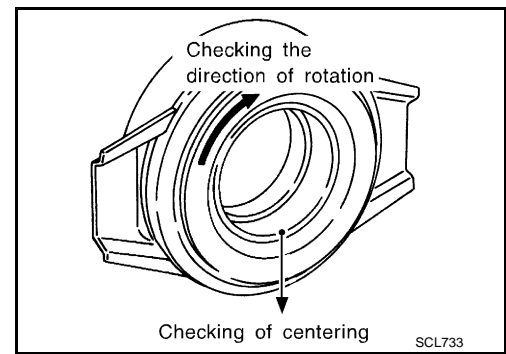

A  
B  
C

CL

E

F

G

H

I

J

K

L

M

N

O

P

# CLUTCH DISC, CLUTCH COVER

< REMOVAL AND INSTALLATION >

## CLUTCH DISC, CLUTCH COVER

5M/T

5M/T : Exploded View

INFOID:000000003297124

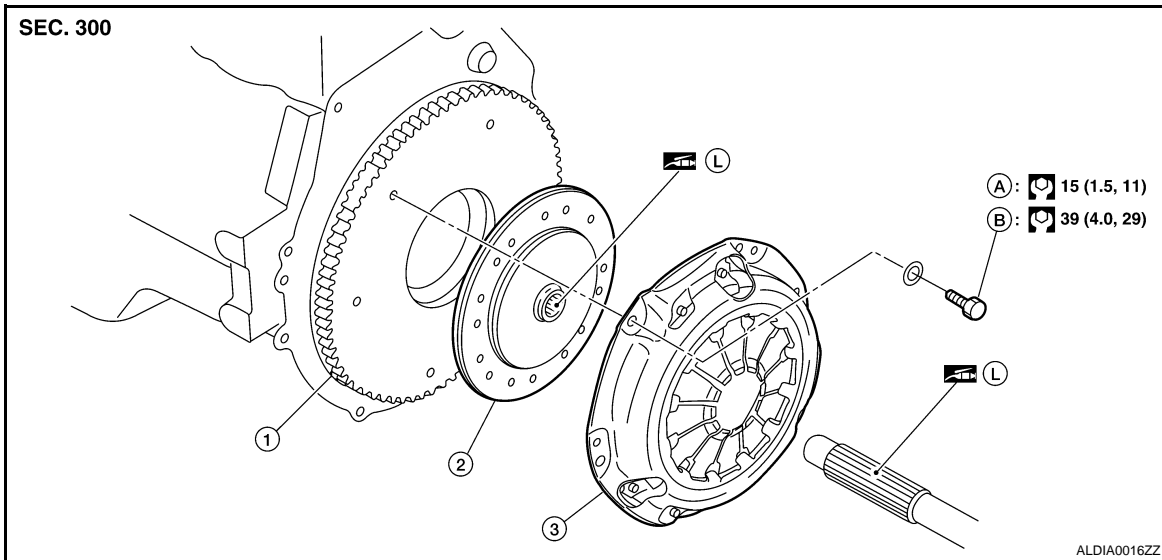

- |               |                |                 |
|---------------|----------------|-----------------|
| 1. Flywheel   | 2. Clutch disc | 3. Clutch cover |
| A. First step | B. Final Step  |                 |

5M/T : Removal and Installation

INFOID:000000003297125

### CAUTION:

- Do not clean the clutch disc with solvent.
- When installing, do not get grease from the main drive shaft onto the clutch disc friction surface.

### REMOVAL

1. Remove the manual transmission from the vehicle. Refer to [TM-19, "Removal and Installation from Vehicle"](#).
2. Remove the clutch cover bolts using power tool. Remove the clutch cover and clutch disc.

### INSTALLATION

1. Apply recommended grease to clutch disc and main drive shaft spline.

### CAUTION:

**Do not allow grease to contaminate the clutch facing.**

# CLUTCH DISC, CLUTCH COVER

## < REMOVAL AND INSTALLATION >

- Install clutch disc and clutch cover. Pre-tighten the bolts and install Tool. Then tighten the clutch cover bolts evenly in two steps to the specified torque in the order shown. Refer to [CL-20, "5M/T : Exploded View"](#).

**Tool number : ST20630000 (J-26366)**

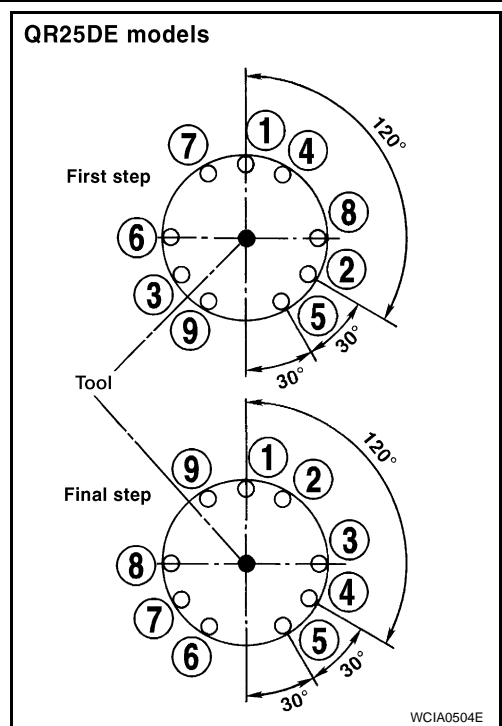

- Install the manual transmission. Refer to [TM-19, "Removal and Installation from Vehicle"](#).

## 5M/T : Inspection and Adjustment

INFOID:000000003297156

### INSPECTION AND ADJUSTMENT AFTER REMOVAL

#### Clutch Disc

- Check the wear of the clutch disc facing.

**Clutch disc facing wear : Refer to [CL-25, "Clutch Disc"](#).**

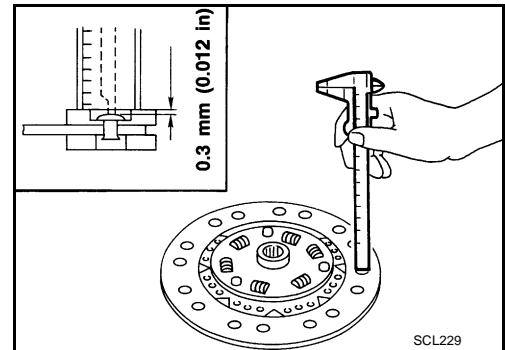

- Check the runout and backlash of the clutch disc. If the measurement exceeds the specification, replace the clutch disc.

**Runout and backlash : Refer to [CL-25, "Clutch Disc"](#).**

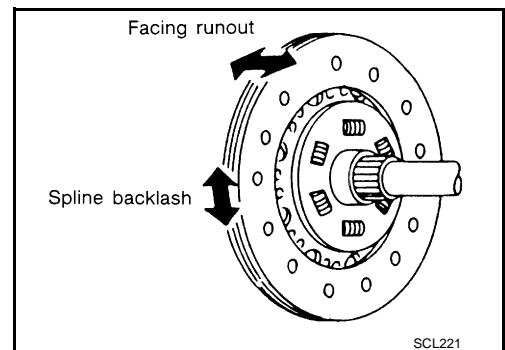

#### Clutch Cover

# CLUTCH DISC, CLUTCH COVER

## < REMOVAL AND INSTALLATION >

With the clutch cover installed on the vehicle, check the diaphragm spring toe height for unevenness. If unevenness exceeds the limit, adjust the diaphragm spring toe height using Tool.

**Uneven limit of diaphragm spring toe height** : Refer to [CL-25, "Clutch Cover"](#).

**Tool number** : ST20050240 ( — )

- Check clutch cover thrust ring for wear or damage. If wear or damage is found, replace clutch cover assembly.

### NOTE:

- Worn thrust ring will generate a beating noise when tapped at the rivet with a hammer.
- Broken thrust ring will make a clinking sound when cover is shaken up and down.
- If a trace of burn or discoloration is found on the clutch cover pressure plate to clutch disc contact surface, repair the surface with emery paper. If surface is damaged or distorted, replace the assembly.

### Flywheel

- Check contact surface of flywheel for slight burns or discoloration. If any are found, repair flywheel with emery paper.
- Check the flywheel runout. Refer to [EM-86, "Inspection After Disassembly"](#).

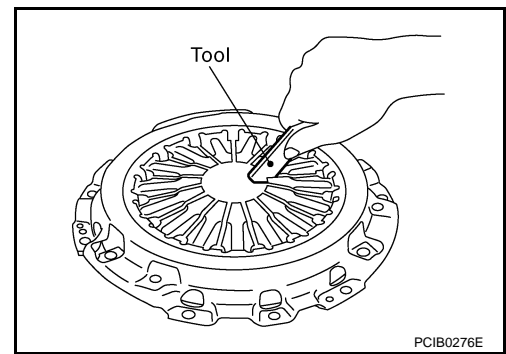

PCIB0276E

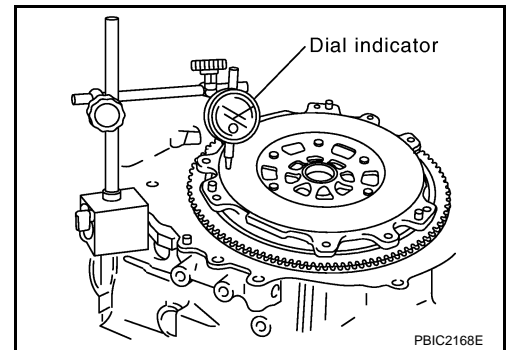

PBIC2168E

6M/T

6M/T : Exploded View

INFOID:000000003297093

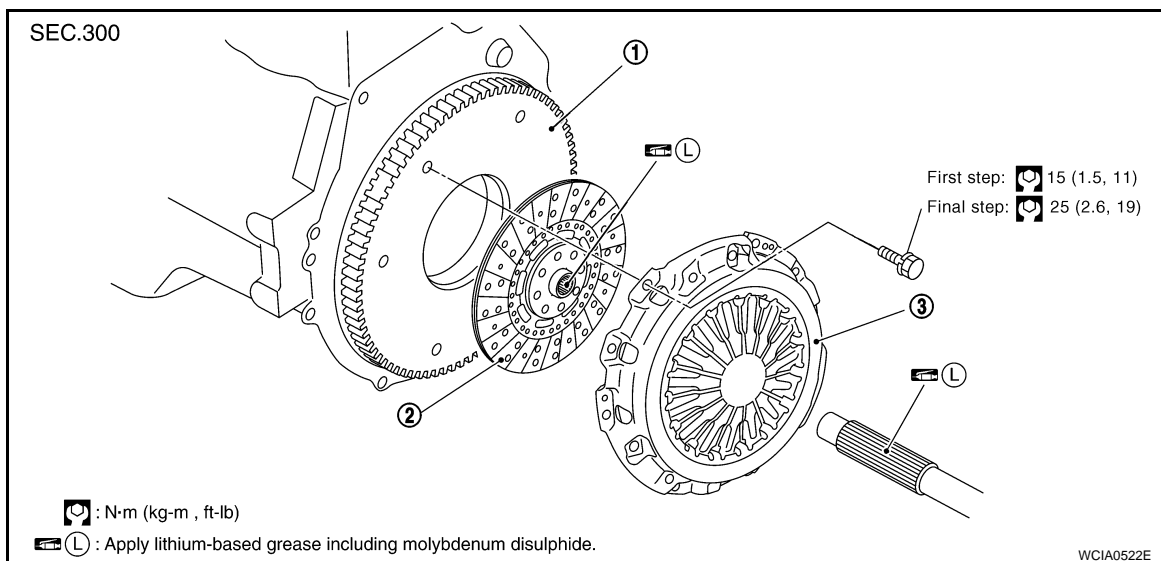

1. Flywheel

2. Clutch disc

3. Clutch cover

6M/T : Removal and Installation

INFOID:000000003297094

### CAUTION:

- Do not clean the clutch disc with solvent.
- When installing, do not get grease from the main drive shaft onto the clutch disc friction surface.

# CLUTCH DISC, CLUTCH COVER

## < REMOVAL AND INSTALLATION >

- If the flywheel is removed, align the dowel pin with the smallest hole of flywheel. Refer to [EM-219, "Disassembly and Assembly"](#).

### REMOVAL

1. Remove the manual transmission from the vehicle. Refer to [TM-75, "Removal and Installation from Vehicle \(For 2WD Models\)"](#) or [TM-77, "Removal and Installation from Vehicle \(For 4WD Models\)"](#).
2. Remove the clutch cover bolts using power tool. Remove the clutch cover and clutch disc.

### INSTALLATION

1. Apply recommended grease to clutch disc and main drive shaft spline.

**CAUTION:**

**Do not allow grease to contaminate the clutch facing.**

2. Install clutch disc and clutch cover. Pre-tighten the bolts and install Tool. Then tighten the clutch cover bolts evenly in two steps to the specified torque in the order shown. Refer to [CL-22, "6M/T : Exploded View"](#).

**Tool number : ST20630000 (J-26366)**

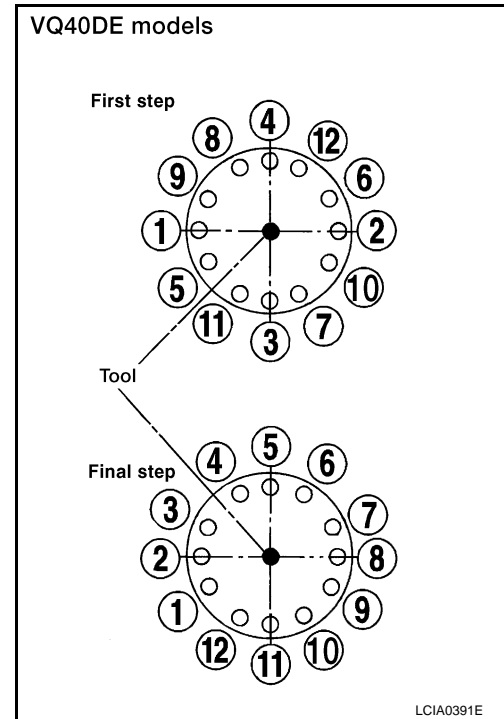

3. Install the manual transmission. Refer to [TM-75, "Removal and Installation from Vehicle \(For 2WD Models\)"](#) or [TM-77, "Removal and Installation from Vehicle \(For 4WD Models\)"](#).

## 6M/T : Inspection and Adjustment

INFOID:000000003297095

### INSPECTION AND ADJUSTMENT AFTER REMOVAL

#### Clutch Disc

- Check the wear of the clutch disc facing.

**Clutch disc facing wear : Refer to [CL-25, "Clutch Disc"](#).**

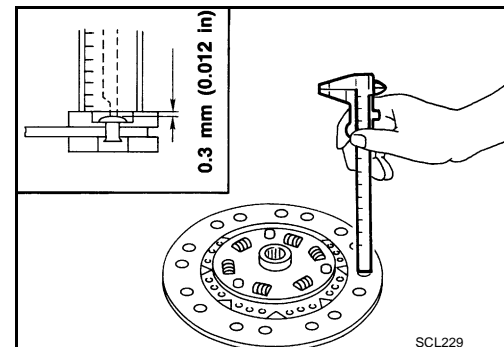

# CLUTCH DISC, CLUTCH COVER

## < REMOVAL AND INSTALLATION >

- Check the runout and backlash of the clutch disc. If the measurement exceeds the specification, replace the clutch disc.

**Runout and backlash** : Refer to [CL-25, "Clutch Disc"](#).

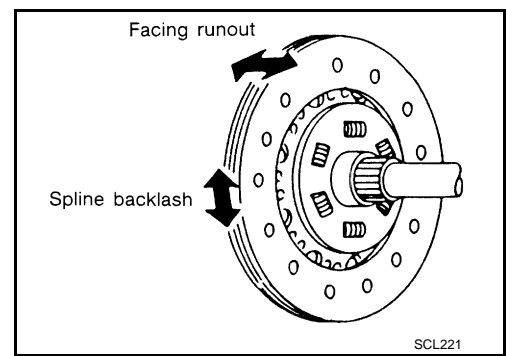

### Clutch Cover

With the clutch cover installed on the vehicle, check the diaphragm spring toe height for unevenness. If unevenness exceeds the limit, adjust the diaphragm spring toe height using Tool.

**Uneven limit of diaphragm spring toe height** : Refer to [CL-25, "Clutch Cover"](#).

**Tool number** : ST20050240 ( — )

- Check clutch cover thrust ring for wear or damage. If wear or damage is found, replace clutch cover assembly.

#### NOTE:

- Worn thrust ring will generate a beating noise when tapped at the rivet with a hammer.
- Broken thrust ring will make a clinking sound when cover is shaken up and down.
- If a trace of burn or discoloration is found on the clutch cover pressure plate to clutch disc contact surface, repair the surface with emery paper. If surface is damaged or distorted, replace the assembly.

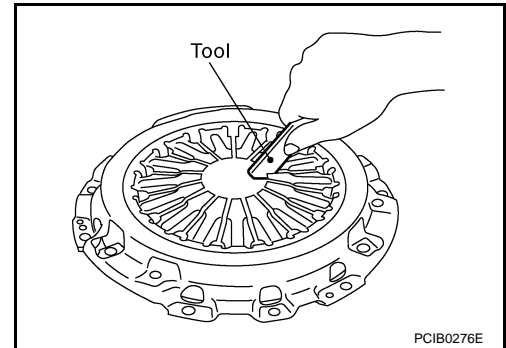

### Flywheel

- Check contact surface of flywheel for slight burns or discoloration. If any are found, repair flywheel with emery paper.
- Check the flywheel runout. Refer to [EM-229, "Inspection After Disassembly"](#).

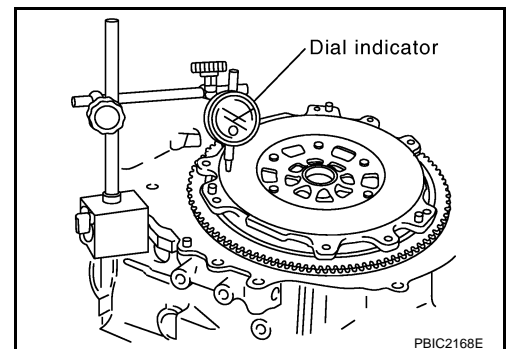



# SERVICE DATA AND SPECIFICATIONS (SDS)

< SERVICE DATA AND SPECIFICATIONS (SDS)

## SERVICE DATA AND SPECIFICATIONS (SDS)

### SERVICE DATA AND SPECIFICATIONS (SDS)

#### Clutch Control System

INFOID:000000003297160

Type of clutch control	Hydraulic
------------------------	-----------

#### Clutch Master Cylinder

INFOID:000000003297161

Unit: mm (in)

Inner diameter	15.87 (5/8)
----------------	-------------

#### Clutch Operating Cylinder

INFOID:000000003297162

Unit: mm (in)

Inner diameter	19.05 (3/4)
----------------	-------------

#### Clutch Disc

INFOID:000000003297163

Unit: mm (in)

Engine model	QR25DE	VQ40DE
Model	240	260
Transmission Model	5 M/T	6 M/T
Facing size (Outer dia. × inner dia. × thickness)	240 × 160 × 3.5 (9.45 × 6.30 × 0.138)	260 × 190 × 3.2 (10.24 × 7.48 × 0.126)
Wear limit (depth to rivet head)	0.3 (0.012)	
Runout limit/diameter of the area to be measured	0.7 (0.028) or less/230 (9.06) dia.	1.0 (0.039) or less/250 (9.84) dia.
Maximum backlash of spline (at outer disc edge)	1.0 (0.039)	

#### Clutch Cover

INFOID:000000003297164

Unit: mm (in)

Engine model	QR25DE	VQ40DE
Transmission Model	5 M/T	6 M/T
Set-load	5890 N (600 kg, 1324 lb)	8340 N (850 kg, 1875 lb)
Diaphragm spring lever height	37.0 - 39.0 (1.457 - 1.535)	44.0 - 46.0 (1.732 - 1.811)
Uneven limit of diaphragm spring toe height	0.7 (0.028)	

#### Clutch Pedal

INFOID:000000003297165

Unit: mm (in)

Clearance "C" between pedal stopper rubber and clutch interlock switch threaded while clutch pedal is fully depressed.	0.1 - 1.0 (0.004 - 0.039)
--	---------------------------