

# SECTION **PWC**

## POWER WINDOW CONTROL SYSTEM

A  
B  
C  
D  
E  
F  
G  
H  
I  
J  
L  
M  
N  
O  
P

### CONTENTS

<p><b>BASIC INSPECTION</b> ..... 3</p> <p><b>DIAGNOSIS AND REPAIR WORKFLOW</b> ..... 3</p> <p style="padding-left: 20px;">Work Flow .....3</p> <p><b>FUNCTION DIAGNOSIS</b> ..... 4</p> <p><b>POWER WINDOW SYSTEM</b> ..... 4</p> <p style="padding-left: 20px;">System Diagram .....4</p> <p style="padding-left: 20px;">System Description .....4</p> <p style="padding-left: 20px;">Component Parts Location .....5</p> <p style="padding-left: 20px;">Component Description .....6</p> <p><b>DIAGNOSIS SYSTEM (BCM)</b> ..... 7</p> <p><b>COMMON ITEM</b> .....7</p> <p style="padding-left: 20px;">COMMON ITEM : CONSULT-III Function (BCM - COMMON ITEM) .....7</p> <p><b>RETAINED PWR</b> .....7</p> <p style="padding-left: 20px;">RETAINED PWR : CONSULT-III Function (BCM - RETAINED PWR) .....7</p> <p><b>COMPONENT DIAGNOSIS</b> ..... 9</p> <p><b>POWER SUPPLY AND GROUND CIRCUIT</b> ..... 9</p> <p><b>POWER WINDOW MAIN SWITCH (CREW CAB)</b> .....9</p> <p style="padding-left: 20px;">POWER WINDOW MAIN SWITCH (CREW CAB) : Description .....9</p> <p style="padding-left: 20px;">POWER WINDOW MAIN SWITCH (CREW CAB) : Component Function Check .....9</p> <p style="padding-left: 20px;">POWER WINDOW MAIN SWITCH (CREW CAB) : Diagnosis Procedure .....9</p> <p style="padding-left: 20px;">POWER WINDOW MAIN SWITCH (CREW CAB) : Component Inspection ..... 12</p> <p><b>POWER WINDOW MAIN SWITCH (KING CAB)</b> ..... 13</p> <p style="padding-left: 20px;">POWER WINDOW MAIN SWITCH (KING CAB) : Description ..... 13</p> <p style="padding-left: 20px;">POWER WINDOW MAIN SWITCH (KING CAB) : Component Function Check ..... 13</p>	<p>POWER WINDOW MAIN SWITCH (KING CAB) : Diagnosis Procedure .....13</p> <p>POWER WINDOW MAIN SWITCH (KING CAB) : Component Inspection .....15</p> <p><b>FRONT POWER WINDOW SWITCH</b> .....15</p> <p style="padding-left: 20px;">FRONT POWER WINDOW SWITCH : Description ..... 15</p> <p style="padding-left: 20px;">FRONT POWER WINDOW SWITCH : Component Function Check ..... 15</p> <p style="padding-left: 20px;">FRONT POWER WINDOW SWITCH : Diagnosis Procedure ..... 15</p> <p><b>REAR POWER WINDOW SWITCH</b> .....16</p> <p style="padding-left: 20px;">REAR POWER WINDOW SWITCH : Description....16</p> <p style="padding-left: 20px;">REAR POWER WINDOW SWITCH : Component Function Check .....17</p> <p style="padding-left: 20px;">REAR POWER WINDOW SWITCH : Diagnosis Procedure .....17</p> <p style="padding-left: 20px;">REAR POWER WINDOW SWITCH : Component Inspection .....18</p> <p><b>POWER WINDOW MOTOR</b> .....20</p> <p><b>DRIVER SIDE</b> .....20</p> <p style="padding-left: 20px;">DRIVER SIDE : Description .....20</p> <p style="padding-left: 20px;">DRIVER SIDE : Component Function Check .....20</p> <p style="padding-left: 20px;">DRIVER SIDE : Diagnosis Procedure .....20</p> <p style="padding-left: 20px;">DRIVER SIDE : Component Inspection .....21</p> <p><b>PASSENGER SIDE</b> .....21</p> <p style="padding-left: 20px;">PASSENGER SIDE : Description .....21</p> <p style="padding-left: 20px;">PASSENGER SIDE : Component Function Check .....21</p> <p style="padding-left: 20px;">PASSENGER SIDE : Diagnosis Procedure .....21</p> <p style="padding-left: 20px;">PASSENGER SIDE : Component Inspection .....22</p> <p><b>REAR LH</b> .....23</p> <p style="padding-left: 20px;">REAR LH : Description .....23</p> <p style="padding-left: 20px;">REAR LH : Component Function Check .....23</p> <p style="padding-left: 20px;">REAR LH : Diagnosis Procedure .....23</p> <p style="padding-left: 20px;">REAR LH : Component Inspection .....24</p>
---	--

PWC

<b>REAR RH</b> .....	24	Diagnosis Procedure .....	57
REAR RH : Description .....	24		
REAR RH : Component Function Check .....	24	<b>FRONT PASSENGER SIDE POWER WINDOW ALONE DOES NOT OPERATE</b> .....	58
REAR RH : Diagnosis Procedure .....	25	Diagnosis Procedure .....	58
REAR RH : Component Inspection .....	26		
<b>DOOR SWITCH</b> .....	27	<b>REAR LH SIDE POWER WINDOW ALONE DOES NOT OPERATE</b> .....	59
<b>KING CAB</b> .....	27	Diagnosis Procedure .....	59
KING CAB : Description .....	27	<b>REAR RH SIDE POWER WINDOW ALONE DOES NOT OPERATE</b> .....	60
KING CAB : Component Function Check .....	27	Diagnosis Procedure .....	60
KING CAB : Diagnosis Procedure .....	27	<b>AUTO OPERATION DOES NOT OPERATE BUT MANUAL OPERATE NORMALLY (DRIVER SIDE)</b> .....	61
<b>CREW CAB</b> .....	29	Diagnosis Procedure .....	61
CREW CAB : Description .....	29	<b>POWER WINDOW RETAINED POWER OPERATION DOES NOT OPERATE PROPERLY</b> .....	62
CREW CAB : Component Function Check .....	29	Diagnosis Procedure .....	62
CREW CAB : Diagnosis Procedure .....	29	<b>POWER WINDOW LOCK SWITCH DOES NOT FUNCTION</b> .....	63
<b>POWER WINDOW LOCK SWITCH</b> .....	31	Diagnosis Procedure .....	63
Description .....	31	<b>PRECAUTION</b> .....	64
Component Function Check .....	31	<b>PRECAUTIONS</b> .....	64
Description .....	31	Precaution for Supplemental Restraint System (SRS) "AIR BAG" and "SEAT BELT PRE-TENSIONER" .....	64
<b>ECU DIAGNOSIS</b> .....	32	<b>ON-VEHICLE REPAIR</b> .....	65
<b>BCM (BODY CONTROL MODULE)</b> .....	32	<b>POWER WINDOW MAIN SWITCH</b> .....	65
Reference Value .....	32	Removal and Installation .....	65
Terminal Layout .....	35	<b>FRONT POWER WINDOW SWITCH</b> .....	66
Physical Values .....	36	Removal and Installation .....	66
Wiring Diagram .....	41	<b>REAR POWER WINDOW SWITCH</b> .....	67
Fail Safe .....	44	Removal and Installation - Rear Door Switch (if equipped) .....	67
DTC Inspection Priority Chart .....	45		
DTC Index .....	45		
<b>POWER WINDOW SYSTEM</b> .....	47		
Terminal Layout for Power Window Main Switch ...	47		
Physical Values for Power Window Main Switch ...	47		
Wiring Diagram .....	48		
<b>SYMPTOM DIAGNOSIS</b> .....	56		
<b>NONE OF THE POWER WINDOWS CAN BE OPERATED USING ANY SWITCH</b> .....	56		
Diagnosis Procedure .....	56		
<b>DRIVER SIDE POWER WINDOW ALONE DOES NOT OPERATE</b> .....	57		

# DIAGNOSIS AND REPAIR WORKFLOW

< BASIC INSPECTION >

## BASIC INSPECTION

### DIAGNOSIS AND REPAIR WORKFLOW

Work Flow

INFOID:000000004056251

DETAILED FLOW

#### 1. OBTAIN INFORMATION ABOUT SYMPTOM

Interview the customer to obtain the malfunction information (conditions and environment when the malfunction occurred) as much as possible when the customer brings the vehicle in.

>> GO TO 2

#### 2. REPRODUCE THE MALFUNCTION INFORMATION

Check the malfunction on the vehicle that the customer describes.  
Inspect the relation of the symptoms and the condition when the symptoms occur.

>> GO TO 3

#### 3. IDENTIFY THE MALFUNCTIONING SYSTEM WITH "SYMPTOM DIAGNOSIS"

Use "Symptom diagnosis" from the symptom inspection result in step 2 and then identify where to start performing the diagnosis based on possible causes and symptoms.

>> GO TO 4

#### 4. IDENTIFY THE MALFUNCTIONING PARTS WITH "COMPONENT DIAGNOSIS"

Perform the diagnosis with "Component diagnosis" of the applicable system.

>> GO TO 5

#### 5. REPAIR OR REPLACE THE MALFUNCTIONING PARTS

Repair or replace the specified malfunctioning parts.

>> GO TO 6

#### 6. FINAL CHECK

Check that malfunctions are not reproduced when obtaining the malfunction information from the customer, referring to the symptom inspection result in step 2.

Are the malfunctions corrected?

YES >> Inspection End.

NO >> GO TO 3

A  
B  
C  
D  
E  
F  
G  
H  
I  
J  
PWC  
L  
M  
N  
O  
P

# POWER WINDOW SYSTEM

< FUNCTION DIAGNOSIS >

## FUNCTION DIAGNOSIS

### POWER WINDOW SYSTEM

#### System Diagram

INFOID:000000004056252

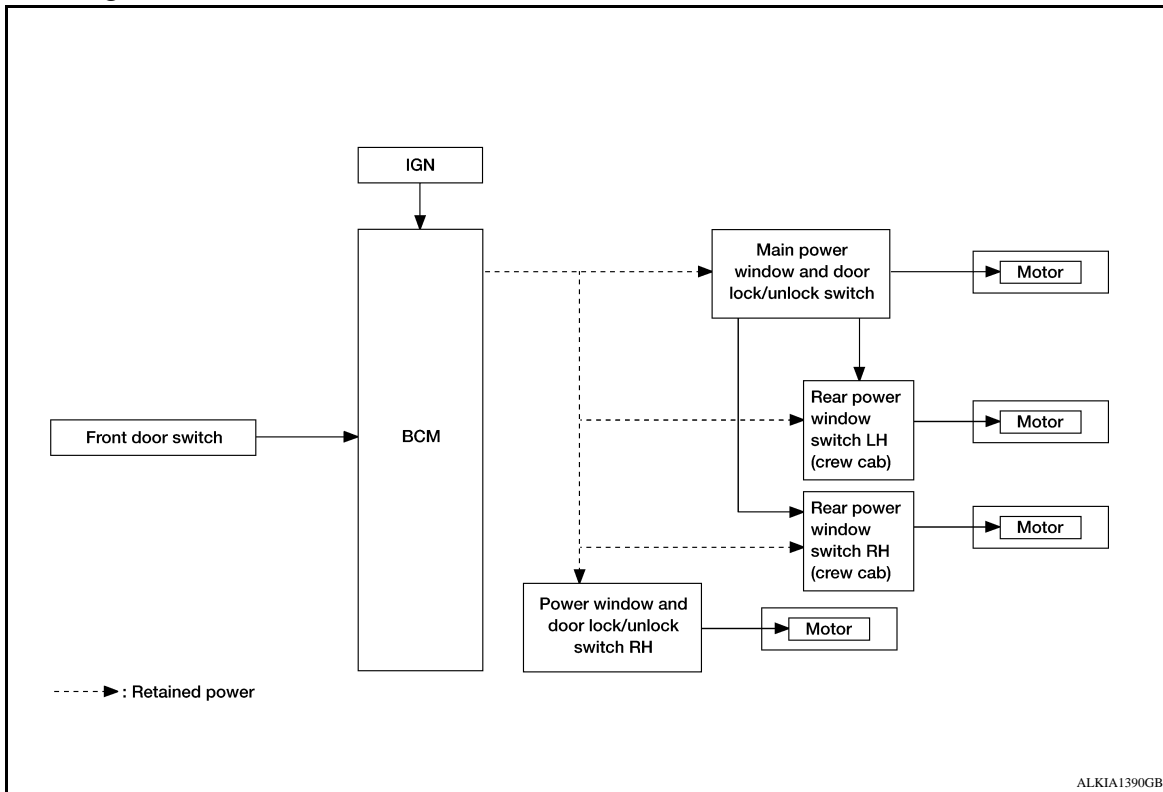

#### System Description

INFOID:000000004056253

#### MAIN POWER WINDOW AND DOOR LOCK/UNLOCK SWITCH INPUT/OUTPUT SIGNAL CHART

Item	Input signal to main power window and door lock/unlock switch	Main power window and door lock/unlock switch function	Actuator
Main power window and door lock/unlock switch	All power window motor UP/DOWN signal	Power window control	Power window motors
Power window and door lock/unlock switch RH	Front power window motor RH UP/DOWN signal		Front power window motor RH
Rear power window switch (crew cab)	Rear power window motor UP/DOWN signal		Rear power window motor
BCM	RAP signal		—

#### POWER WINDOW AND DOOR LOCK/UNLOCK SWITCH RH INPUT/OUTPUT SIGNAL CHART

Item	Input signal to front power window switch	Front power window switch function	Actuator
Power window and door lock/unlock switch RH	Front power window motor RH UP/DOWN signal	Power window control	Front power window motor RH
BCM	RAP signal		

# POWER WINDOW SYSTEM

## < FUNCTION DIAGNOSIS >

### POWER WINDOW OPERATION

- Power window system is operable during the retained power operation timer after turning ignition switch ON and OFF.
- Main power window and door lock/unlock switch can open/close all windows.
- Power window and door lock unlock switch RH & rear power window switches LH and RH (crew cab) can open/close the corresponding windows.

### POWER WINDOW AUTO DOWN OPERATION (FRONT LH)

- AUTO DOWN operation can be performed when main power window turns to AUTO.

### RETAINED POWER OPERATION

- Retained power operation is an additional power supply function that enables power window system to operate during the 45 seconds even when ignition switch is turned OFF

#### Retained power function cancel conditions

- Front door CLOSE (door switch OFF)→OPEN (door switch ON).
- When ignition switch is ON.
- When timer time passes. (45 seconds)

### POWER WINDOW LOCK

Ground circuit inside main power window and door lock/unlock switch shuts off when power window lock switch is ON. This inhibits power window switch operation except with the main power window and door lock/unlock switch.

## Component Parts Location

INFOID:000000004056254

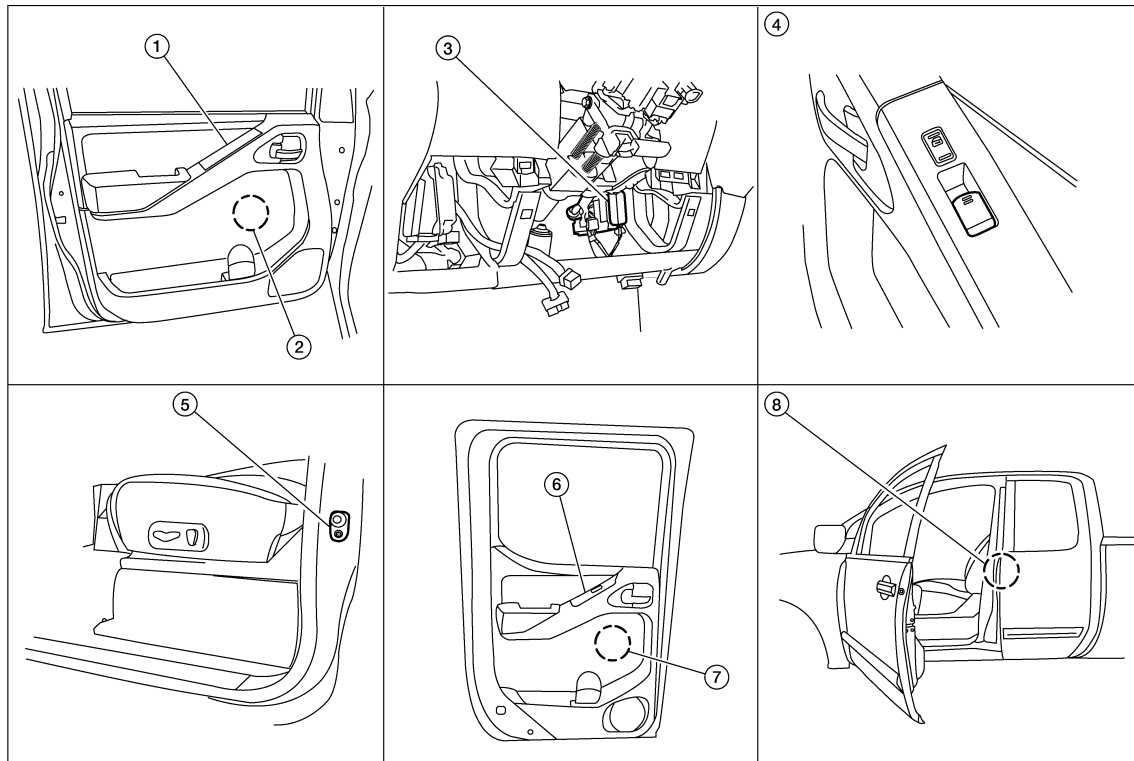

- |   |  |  |
|---|--|--|
| 1. Main power window and door lock/unlock switch D7 | 2. Front power window motor LH D9, RH D104       | 3. BCM M18, M19, M20 (view with lower instrument panel LH removed) |
| 4. Power window and door lock/unlock switch RH D105 | 5. Front door switch (crew cab) LH B8, RH B108   | 6. Rear power window switch LH D203, RH D303                       |
| 7. Rear power window motor LH D204, RH D304         | 8. Front door switch (king cab) LH D213, RH D314 |  |

A  
B  
C  
D  
E  
F  
G  
H  
I  
J  
L  
M  
N  
O

PWC

# POWER WINDOW SYSTEM

< FUNCTION DIAGNOSIS >

## Component Description

INFOID:000000004056255

### FRONT WINDOW ANTI-PINCH SYSTEM

Component	Function
BCM	<ul style="list-style-type: none"><li>• Supplies power supply to power window switch.</li><li>• Controls retained power.</li></ul>
Main power window and door lock/unlock switch	Directly controls all power window motor of all doors.
Power window and door lock/unlock switch RH	Controls front power window motor RH.
Rear power window switch (crew cab)	Controls rear power window motors LH and RH.
Front power window motor LH	Starts operating with signals from main power window and door lock/unlock switch.
Front power window motor RH	Starts operating with signals from main power window and door lock/unlock switch & power window and door lock/unlock switch RH.
Rear power window motor (crew cab)	Starts operating with signals from main power window and door lock/unlock switch & rear power window switch.
Front door switch LH or RH	Detects door open/close condition and transmits to BCM.

# DIAGNOSIS SYSTEM (BCM)

< FUNCTION DIAGNOSIS >

## DIAGNOSIS SYSTEM (BCM)

### COMMON ITEM

#### COMMON ITEM : CONSULT-III Function (BCM - COMMON ITEM)

INFOID:000000004449381

#### APPLICATION ITEM

CONSULT-III performs the following functions via CAN communication with BCM.

Diagnosis mode	Function Description
WORK SUPPORT	Changes the setting for each system function.
SELF-DIAG RESULTS	Displays the diagnosis results judged by BCM. Refer to <a href="#">BCS-52. "DTC Index"</a> .
CAN DIAG SUPPORT MNTR	Monitors the reception status of CAN communication viewed from BCM.
DATA MONITOR	The BCM input/output signals are displayed.
ACTIVE TEST	The signals used to activate each device are forcibly supplied from BCM.
ECU IDENTIFICATION	The BCM part number is displayed.
CONFIGURATION	<ul style="list-style-type: none"> <li>Enables to read and save the vehicle specification.</li> <li>Enables to write the vehicle specification when replacing BCM.</li> </ul>

#### SYSTEM APPLICATION

BCM can perform the following functions for each system.

#### NOTE:

It can perform the diagnosis modes except the following for all sub system selection items.

System	Sub system selection item	Diagnosis mode		
		WORK SUPPORT	DATA MONITOR	ACTIVE TEST
BCM	BCM	×		
Door lock	DOOR LOCK	×	×	×
Warning chime	BUZZER		×	×
Interior room lamp timer	INT LAMP	×	×	×
Remote keyless entry system	MULTI REMOTE ENT	×	×	×
Exterior lamp	HEAD LAMP	×	×	×
Wiper and washer	WIPER	×	×	×
Turn signal and hazard warning lamps	FLASHER		×	×
Air conditioner	AIR CONDITONER		×	
Combination switch	COMB SW		×	
Immobilizer	IMMU		×	×
Interior room lamp battery saver	BATTERY SAVER	×	×	×
Vehicle security system	THEFT ALM	×	×	×
RAP (retained accessory power)	RETAINED PWR	×	×	×
Signal buffer system	SIGNAL BUFFER		×	×
TPMS (tire pressure monitoring system)	AIR PRESSURE MONITOR	×	×	×
Panic alarm system	PANIC ALARM			×

#### RETAINED PWR

#### RETAINED PWR : CONSULT-III Function (BCM - RETAINED PWR)

INFOID:000000004449382

#### DATA MONITOR

# DIAGNOSIS SYSTEM (BCM)

## < FUNCTION DIAGNOSIS >

Monitor Item [Unit]	Description
IGN ON SW [ON/OFF]	Indicates condition of ignition switch.
DOOR SW-DR [ON/OFF]	Indicates condition of front door switch LH.
DOOR SW-AS [ON/OFF]	Indicates condition of front door switch RH.

## ACTIVE TEST

Test Item	Description
RETAINED PWR	<p>This test is able to supply RAP signal (power) from BCM (body control module) to power window system and power sunroof system (if equipped). Those systems can be operated when turning on "RETAINED PWR" on CONSULT-III screen even if the ignition switch is turned OFF.</p> <p><b>NOTE:</b> During this test, CONSULT-III can be operated with ignition switch in OFF position. "RETAINED PWR" should be turned "ON" or "OFF" on CONSULT-III screen when ignition switch is ON. Then turn ignition switch OFF to check retained power operation. CONSULT-III might be stuck if "RETAINED PWR" is turned "ON" or "OFF" on CONSULT-III screen when ignition switch is OFF.</p>

## WORK SUPPORT

Work item	Description
RETAINED PWR SET	<p>RAP signal's power supply period can be changed by mode setting. Selects RAP signal's power supply period between three steps</p> <ul style="list-style-type: none"><li>• MODE1 (45 sec.)/MODE2 (OFF)/MODE 3 (2 min.).</li></ul>



# POWER SUPPLY AND GROUND CIRCUIT

< COMPONENT DIAGNOSIS >

## COMPONENT DIAGNOSIS

### POWER SUPPLY AND GROUND CIRCUIT POWER WINDOW MAIN SWITCH (CREW CAB)

#### POWER WINDOW MAIN SWITCH (CREW CAB) : Description

INFOID:000000004056258

- BCM supplies power.
- It operates each power window motor via corresponding power window switch and makes window move up/down when main power window and door lock/unlock switch is operated.

#### POWER WINDOW MAIN SWITCH (CREW CAB) : Component Function Check

INFOID:000000004056259

##### Main Power Window And Door Lock/Unlock Switch

#### 1. CHECK MAIN POWER WINDOW AND DOOR LOCK/UNLOCK SWITCH FUNCTION

Does power window motor operate with main power window and door lock/unlock switch operation?

Is the inspection result normal?

- YES >> Main power window and door lock/unlock switch power supply and ground circuit are OK.  
NO >> Refer to [PWC-9. "POWER WINDOW MAIN SWITCH \(CREW CAB\) : Diagnosis Procedure"](#).

#### POWER WINDOW MAIN SWITCH (CREW CAB) : Diagnosis Procedure

INFOID:000000004056260

##### Main Power Window And Door Lock/Unlock Switch Power Supply Circuit Check

#### 1. CHECK POWER SUPPLY CIRCUIT

1. Turn ignition switch ON.
2. Check voltage between main power window and door lock/unlock switch connector D7 terminal 5 and ground.

**5 - Ground** : **Battery voltage**

Is the measurement value within the specification?

- YES >> GO TO 2  
NO >> GO TO 3

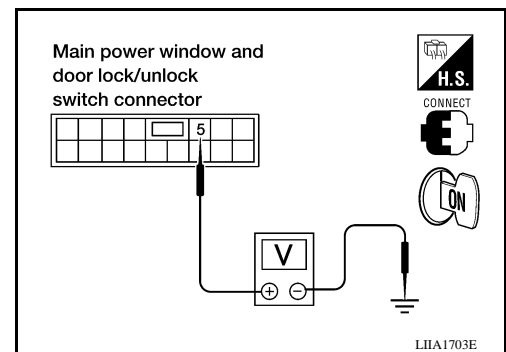

#### 2. CHECK GROUND CIRCUIT

1. Turn ignition switch OFF.
2. Disconnect main power window and door lock/unlock switch.
3. Check continuity between main power window and door lock/unlock switch connector D7 terminal 14 and ground.

Connector	Terminals		Continuity
Main power window and door lock/unlock switch: D7	14	Ground	Yes

Is the inspection result normal?

- YES >> GO TO 4  
NO >> Repair or replace harness.

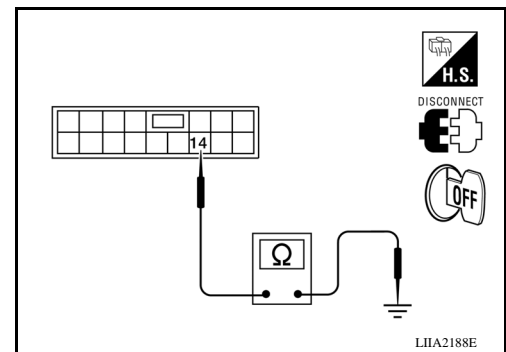

#### 3. CHECK MAIN POWER WINDOW AND DOOR LOCK/UNLOCK SWITCH POWER SUPPLY CIRCUIT

# POWER SUPPLY AND GROUND CIRCUIT

## < COMPONENT DIAGNOSIS >

1. Turn ignition switch OFF.
2. Disconnect BCM and main power window and door lock/unlock switch.
3. Check continuity between BCM and main power window and door lock/unlock switch.

A		B		Continuity
Connector	Terminal	Connector	Terminal	
BCM: M20	68	Main power window and door lock/unlock switch: D7	5	Yes

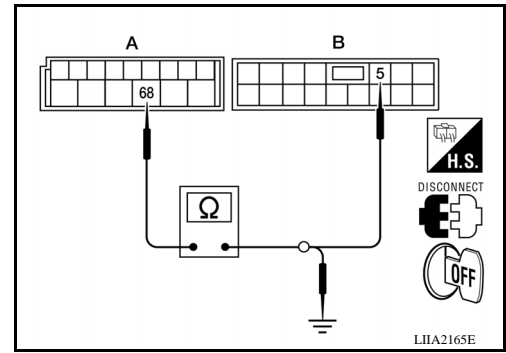

4. Check continuity between BCM and ground.

A		Ground	Continuity
Connector	Terminal		
BCM: M20	68		No

Is the inspection result normal?

- YES >> Replace main power window and door lock/unlock switch. Refer to [PWC-65. "Removal and Installation"](#).
- NO >> Repair or replace harness.

## 4. CHECK BCM OUTPUT SIGNAL

1. Connect BCM.
2. Turn ignition switch ON.
3. Check voltage between BCM connector M20 terminal 68 and ground.

**68 - Ground : Battery voltage**

Is the measurement value within the specification?

- YES >> Check main power window and door lock/unlock switch output signal (rear power window switch LH) GO TO 5
- YES >> Check main power window and door lock/unlock switch output signal (rear power window switch RH) GO TO 6
- NO >> Replace BCM. Refer to [BCS-56. "Removal and Installation"](#).

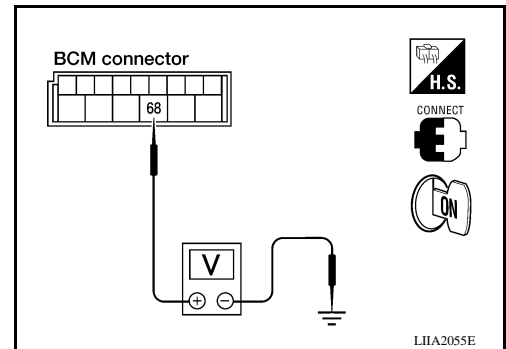

## 5. CHECK MAIN POWER WINDOW AND DOOR LOCK/UNLOCK SWITCH OUTPUT SIGNAL (REAR POWER WINDOW SWITCH LH)

1. Turn ignition switch ON.
2. Check voltage between main power window and door lock/unlock switch connector and ground.

Terminal (+)		Terminal (-)	Window condition	Voltage (V) (Approx.)
Main power window and door lock/unlock switch connector	Terminal			
D7	15	Ground	UP	Battery voltage
			DOWN	0
	16		UP	0
			DOWN	Battery voltage

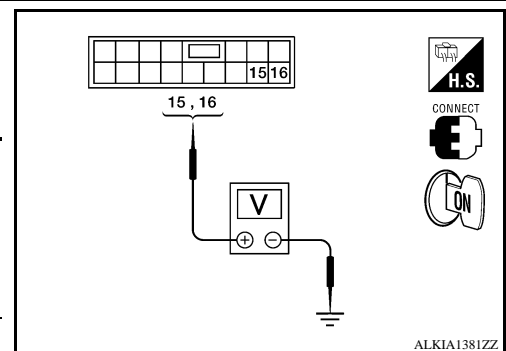

Is the measurement value within the specification?

- YES >> GO TO 7

# POWER SUPPLY AND GROUND CIRCUIT

## < COMPONENT DIAGNOSIS >

NO >> Replace main power window and door lock/unlock switch. Refer to [PWC-65. "Removal and Installation"](#).

### 6. CHECK MAIN POWER WINDOW AND DOOR LOCK/UNLOCK SWITCH OUTPUT SIGNAL (REAR POWER WINDOW SWITCH RH)

1. Turn ignition switch ON.
2. Check voltage between main power window and door lock/unlock switch connector and ground.

Terminal (+)		Terminal (-)	Window condition	Voltage (V) (Approx.)
Main power window and door lock/unlock switch connector	Terminal			
D7	8	Ground	UP	Battery voltage
			DOWN	0
	9		UP	0
			DOWN	Battery voltage

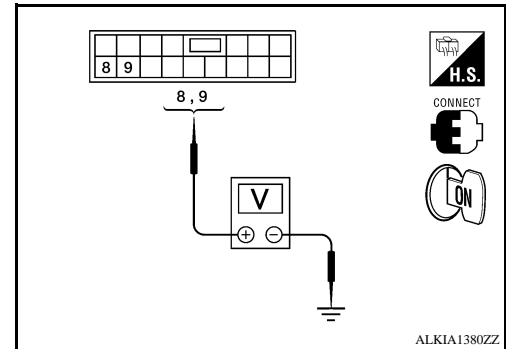

Is the measurement value within the specification?

YES >> GO TO 8

NO >> Replace main power window and door lock/unlock switch. Refer to [PWC-65. "Removal and Installation"](#).

### 7. CHECK HARNESS CONTINUITY (REAR POWER WINDOW SWITCH LH)

1. Turn ignition switch OFF.
2. Disconnect rear power window switch LH.
3. Check continuity between main power window and door lock/unlock switch connector and rear power window switch LH connector.

Main power window and door lock/unlock switch connector	Terminal	Rear power window switch LH connector	Terminal	Continuity
D7	15	D203	4	Yes
	16		5	

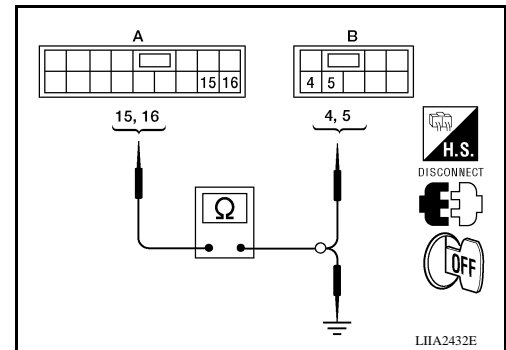

4. Check continuity between main power window and door lock/unlock switch connector and ground.

Main power window and door lock/unlock switch connector	Terminal	Ground	Continuity
D7	15	Ground	No
	16		

Is the inspection result normal?

YES >> GO TO 9

NO >> Repair or replace harness.

### 8. CHECK HARNESS CONTINUITY (REAR POWER WINDOW SWITCH RH)

# POWER SUPPLY AND GROUND CIRCUIT

## < COMPONENT DIAGNOSIS >

1. Turn ignition switch OFF.
2. Disconnect rear power window switch RH.
3. Check continuity between main power window and door lock/unlock switch connector and rear power window switch RH connector.

Main power window and door lock/unlock switch connector	Terminal	Rear power window switch RH connector	Terminal	Continuity
D7	8	D303	4	Yes
	9		5	

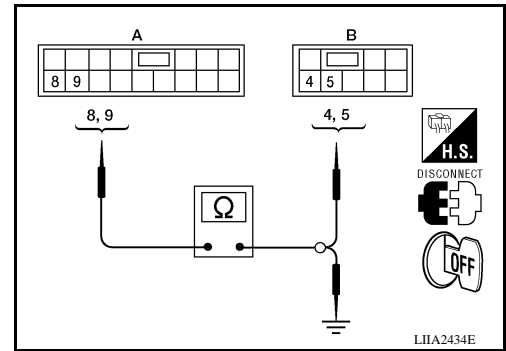

4. Check continuity between main power window and door lock/unlock switch connector and ground.

Main power window and door lock/unlock switch connector	Terminal	Ground	Continuity
D7	8	Ground	No
	9		

Is the inspection result normal?

- YES >> GO TO 9  
 NO >> Repair or replace harness.

## 9. CHECK MAIN POWER WINDOW AND DOOR LOCK/UNLOCK SWITCH

Check main power window and door lock/unlock switch.

Refer to [PWC-12. "POWER WINDOW MAIN SWITCH \(CREW CAB\) : Component Inspection"](#).

Is the inspection result normal?

- YES >> Check intermittent incident. Refer to [GI-49. "Intermittent Incident"](#).  
 NO >> Replace main power window and door lock/unlock switch. Refer to [PWC-65. "Removal and Installation"](#).

## POWER WINDOW MAIN SWITCH (CREW CAB) : Component Inspection INFOID:000000004056261

### 1. CHECK MAIN POWER WINDOW AND DOOR LOCK/UNLOCK SWITCH

1. Check continuity between main power window and door lock/unlock switch terminals for front window RH.

Main power window and door lock/unlock switch	Terminals		Condition	Continuity
	14	2	Lock switch UNLOCK	Yes
Lock switch LOCK			No	
3		Lock switch UNLOCK	Yes	
		Lock switch LOCK	No	

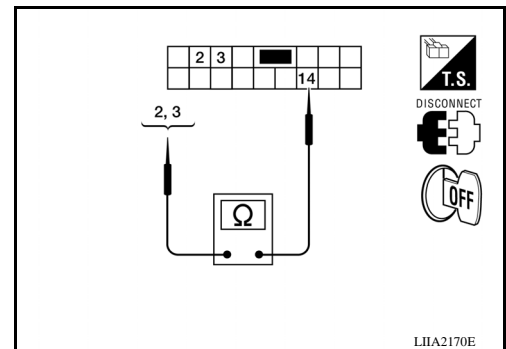

2. Check continuity between main power window and door lock/unlock switch terminals for rear window LH.

Main power window and door lock/unlock switch	Terminals		Condition	Continuity
	14	15	Lock switch UNLOCK	Yes
Lock switch LOCK			No	
16		Lock switch UNLOCK	Yes	
		Lock switch LOCK	No	

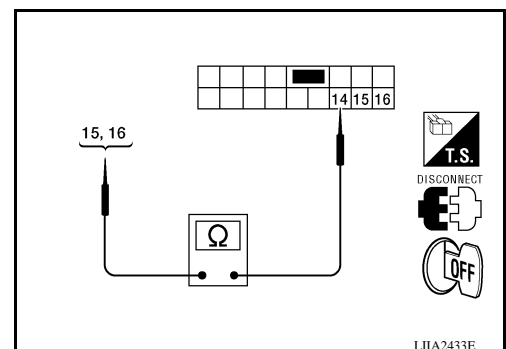

# POWER SUPPLY AND GROUND CIRCUIT

## < COMPONENT DIAGNOSIS >

- Check continuity between main power window and door lock/unlock switch terminals for rear window RH.

Main power window and door lock/unlock switch	Terminals		Condition	Continuity
	14	8	Lock switch UNLOCK	Yes
Lock switch LOCK			No	
9		Lock switch UNLOCK	Yes	
		Lock switch LOCK	No	

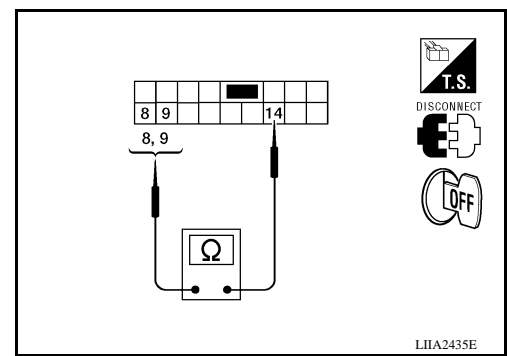

Is the inspection result normal?

- YES >> Main power window and door lock/unlock switch is OK.
- NO >> Replace main power window and door lock/unlock switch. Refer to [PWC-65. "Removal and Installation"](#).

## POWER WINDOW MAIN SWITCH (KING CAB)

### POWER WINDOW MAIN SWITCH (KING CAB) : Description

INFOID:000000004056262

- BCM supplies power.
- It operates each power window motor via corresponding power window switch and makes window move up/down when main power window and door lock/unlock switch is operated.

### POWER WINDOW MAIN SWITCH (KING CAB) : Component Function Check

INFOID:000000004056263

#### Main Power Window And Door Lock/Unlock Switch

#### 1. CHECK MAIN POWER WINDOW AND DOOR LOCK/UNLOCK SWITCH FUNCTION

Does power window motor operate with main power window and door lock/unlock switch operation?

Is the inspection result normal?

- YES >> Main power window and door lock/unlock switch power supply and ground circuit are OK.
- NO >> Refer to [PWC-13. "POWER WINDOW MAIN SWITCH \(KING CAB\) : Diagnosis Procedure"](#).

### POWER WINDOW MAIN SWITCH (KING CAB) : Diagnosis Procedure

INFOID:000000004056264

#### Main Power Window And Door Lock/Unlock Switch Power Supply Circuit Check

#### 1. CHECK POWER SUPPLY CIRCUIT

- Turn ignition switch ON.
- Check voltage between main power window and door lock/unlock switch connector D7 terminal 5 and ground.

**5 - Ground** : **Battery voltage**

Is the measurement value within the specification?

- YES >> GO TO 2
- NO >> GO TO 3

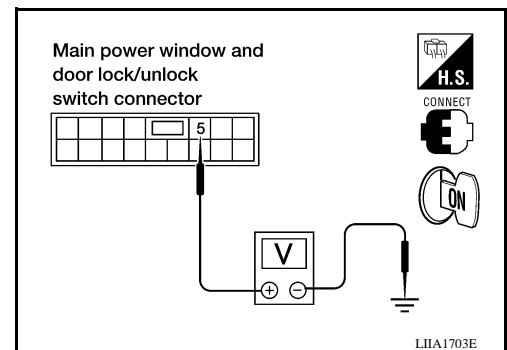

#### 2. CHECK GROUND CIRCUIT

A  
B  
C  
D  
E  
F  
G  
H  
I  
J  
L  
M  
N  
O  
P

PWC

# POWER SUPPLY AND GROUND CIRCUIT

## < COMPONENT DIAGNOSIS >

1. Turn ignition switch OFF.
2. Disconnect main power window and door lock/unlock switch.
3. Check continuity between main power window and door lock/unlock switch connector D7 terminal 14 and ground.

Connector	Terminals		Continuity
Main power window and door lock/unlock switch: D7	14	Ground	Yes

Is the inspection result normal?

- YES >> GO TO 4  
 NO >> Repair or replace harness.

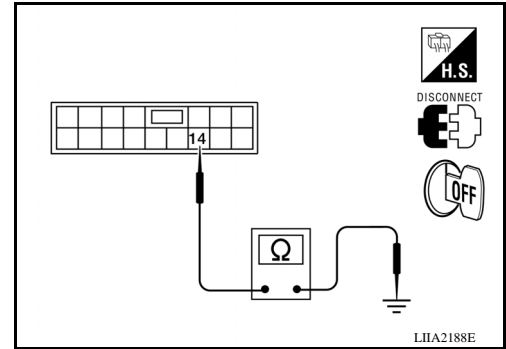

### 3. CHECK MAIN POWER WINDOW AND DOOR LOCK/UNLOCK SWITCH POWER SUPPLY CIRCUIT

1. Turn ignition switch OFF.
2. Disconnect BCM and main power window and door lock/unlock switch.
3. Check continuity between BCM and main power window and door lock/unlock switch.

A		B		Continuity
Connector	Terminal	Connector	Terminal	
BCM: M20	68	Main power window and door lock/unlock switch: D7	5	Yes

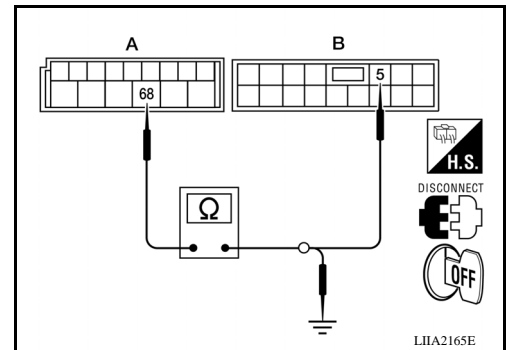

4. Check continuity between BCM and ground.

A		Ground	Continuity
Connector	Terminal		
BCM: M20	68	No	

Is the inspection result normal?

- YES >> Replace main power window and door lock/unlock switch. Refer to [PWC-65, "Removal and Installation"](#).  
 NO >> Repair or replace harness.

### 4. CHECK BCM OUTPUT SIGNAL

1. Connect BCM.
2. Turn ignition switch ON.
3. Check voltage between BCM connector M20 terminal 68 and ground.

**68 - Ground : Battery voltage**

Is the measurement value within the specification?

- YES >> GO TO 5  
 NO >> Replace BCM. Refer to [BCS-56, "Removal and Installation"](#).

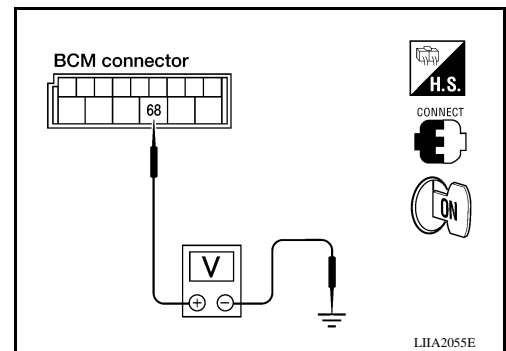

### 5. CHECK MAIN POWER WINDOW AND DOOR LOCK/UNLOCK SWITCH

Check main power window and door lock/unlock switch.  
 Refer to [PWC-15, "POWER WINDOW MAIN SWITCH \(KING CAB\) : Component Inspection"](#).

Is the inspection result normal?

- YES >> Check intermittent incident. Refer to [GI-49, "Intermittent Incident"](#).  
 NO >> Replace main power window and door lock/unlock switch. Refer to [PWC-65, "Removal and Installation"](#).

# POWER SUPPLY AND GROUND CIRCUIT

< COMPONENT DIAGNOSIS >

## POWER WINDOW MAIN SWITCH (KING CAB) : Component Inspection

INFOID:000000004056265

### 1. CHECK MAIN POWER WINDOW AND DOOR LOCK/UNLOCK SWITCH

1. Turn ignition switch OFF.
2. Disconnect main power window and door lock/unlock switch.
3. Check continuity between main power window and door lock/unlock switch terminals for front window RH.

	Terminals		Condition	Continuity
	Main power window and door lock/unlock switch	14	2	Lock switch UNLOCK
Lock switch LOCK				No
3		Lock switch UNLOCK	Yes	
		Lock switch LOCK	No	

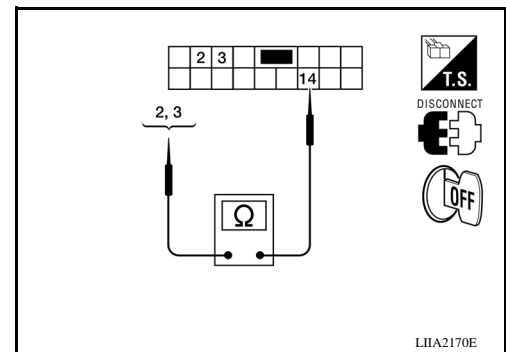

Is the inspection result normal?

YES >> Main power window and door lock/unlock switch is OK.

NO >> Replace main power window and door lock/unlock switch. Refer to [PWC-65. "Removal and Installation"](#).

## FRONT POWER WINDOW SWITCH

### FRONT POWER WINDOW SWITCH : Description

INFOID:000000004056266

- BCM supplies power.
- Front power window motor RH will be operated if power window and door lock/unlock switch RH is operated.

### FRONT POWER WINDOW SWITCH : Component Function Check

INFOID:000000004056267

Power Window And Door Lock/Unlock Switch RH

### 1. CHECK FRONT POWER WINDOW MOTOR RH FUNCTION

Does front power window motor RH operate with power window and door lock/unlock switch RH operation?

Is the inspection result normal?

YES >> Power window and door lock/unlock switch RH power supply and ground circuit are OK.

NO >> Refer to [PWC-15. "FRONT POWER WINDOW SWITCH : Diagnosis Procedure"](#).

### FRONT POWER WINDOW SWITCH : Diagnosis Procedure

INFOID:000000004056268

Power Window And Door Lock/Unlock Switch RH Power Supply Circuit Check

### 1. CHECK POWER SUPPLY CIRCUIT

1. Turn ignition switch ON.
2. Check voltage between power window and door lock/unlock switch RH connector and ground.

Terminal		Terminal	Voltage (V) (Approx.)
(+)	(-)		
Power window and door lock/unlock switch RH connector	8	Ground	Battery voltage

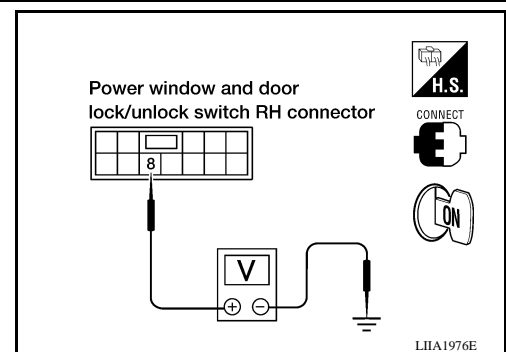

Is the measurement value within the specification?

YES >> GO TO 3

NO >> GO TO 2

### 2. CHECK HARNESS CONTINUITY

A  
B  
C  
D  
E  
F  
G  
H  
I  
J  
L  
M  
N  
O  
P

PWC

# POWER SUPPLY AND GROUND CIRCUIT

## < COMPONENT DIAGNOSIS >

1. Turn ignition switch OFF.
2. Disconnect BCM and power window and door lock/unlock switch RH.
3. Check continuity between BCM connector (A) and power window and door lock/unlock switch RH connector (B).

BCM connector	Terminal	Power window and door lock/unlock switch RH connector	Terminal	Continuity
M20 (A)	68	D105 (B)	8	Yes

4. Check continuity between BCM connector (A) and ground.

BCM connector	Terminal	Ground	Continuity
M20 (A)	68		No

Is the inspection result normal?

YES >> GO TO 4

NO >> Repair or replace harness.

### 3. CHECK GROUND CIRCUIT

1. Turn ignition switch OFF.
2. Disconnect power window and door lock/unlock switch RH.
3. Check continuity between power window and door lock/unlock switch RH connector and ground.

Connector	Terminals	Continuity
Power window and door lock/unlock switch RH: D105	11	Yes
	12	Yes

Is the inspection result normal?

YES >> Replace power window and door lock/unlock switch RH.  
Refer to [PWC-66, "Removal and Installation"](#).

NO >> Repair or replace harness.

### 4. CHECK BCM OUTPUT SIGNAL

1. Connect BCM.
2. Turn ignition switch ON.
3. Check voltage between BCM connector and ground.

Terminals			Voltage (V) (Approx.)
(+)		(-)	
BCM connector	Terminal		
M20	68	Ground	Battery voltage

Is the measurement value within the specification?

YES >> Replace power window and door lock/unlock switch RH.  
Refer to [PWC-66, "Removal and Installation"](#).

NO >> Replace BCM. Refer to [BCS-56, "Removal and Installation"](#).

## REAR POWER WINDOW SWITCH

### REAR POWER WINDOW SWITCH : Description

- BCM supplies power.
- Rear power window motor will be operated if rear power window switch is operated.

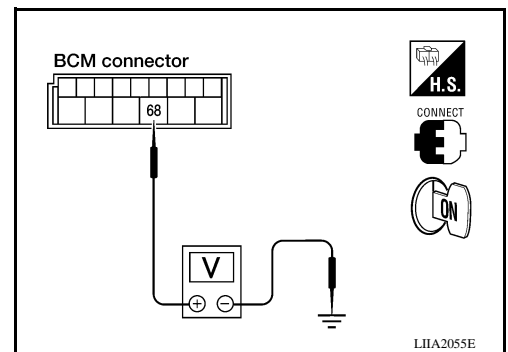
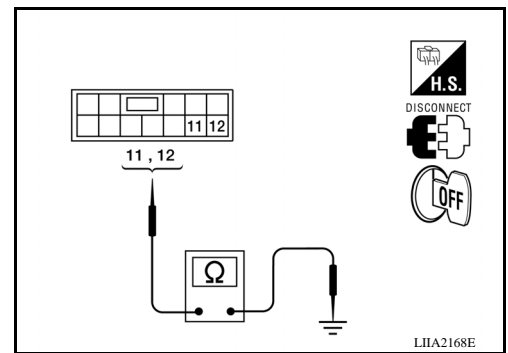
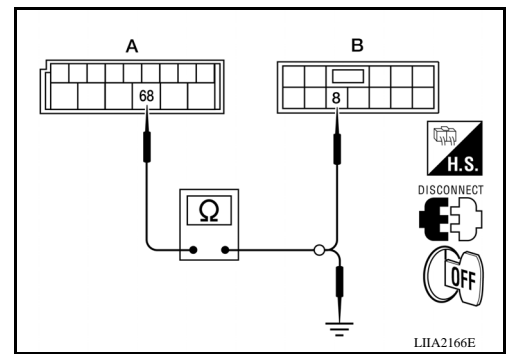



# POWER SUPPLY AND GROUND CIRCUIT

< COMPONENT DIAGNOSIS >

## REAR POWER WINDOW SWITCH : Component Function Check

INFOID:000000004056270

Rear Power Window Switch

### 1. CHECK REAR POWER WINDOW MOTOR FUNCTION

Does rear power window motor operate with rear power window switch operation?

Is the inspection result normal?

- YES >> Rear power window switch power supply and ground circuit are OK.
- NO >> Refer to [PWC-17, "REAR POWER WINDOW SWITCH : Diagnosis Procedure"](#).

## REAR POWER WINDOW SWITCH : Diagnosis Procedure

INFOID:000000004056271

Rear Power Window Switch Power Supply Circuit Check

### 1. CHECK POWER SUPPLY CIRCUIT

1. Turn ignition switch ON.
2. Check voltage between rear power window switch connector and ground.

Terminal		Terminal	Condition	Voltage (V) (Approx.)
(+)	(-)			
Rear power window switch connector		8	Ignition switch ON	Battery voltage
LH	D203			
RH	D303			

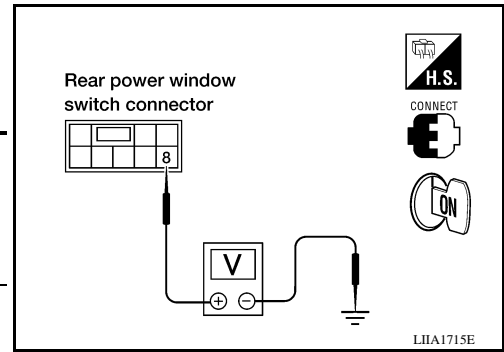

Is the measurement value within the specification?

- YES >> GO TO 2 (Rear power window switch LH)
- YES >> GO TO 3 (Rear power window switch RH)
- NO >> GO TO 4

### 2. CHECK HARNESS CONTINUITY (REAR POWER WINDOW SWITCH LH)

1. Turn ignition switch OFF.
2. Disconnect main power window and door lock/unlock switch and rear power window switch LH.
3. Check continuity between main power window and door lock/unlock switch connector (A) and rear power window switch LH connector (B).

Main power window and door lock/unlock switch connector	Terminal	Rear power window switch LH connector	Terminal	Continuity
D7 (A)	15	D203 (B)	4	Yes
	16		5	

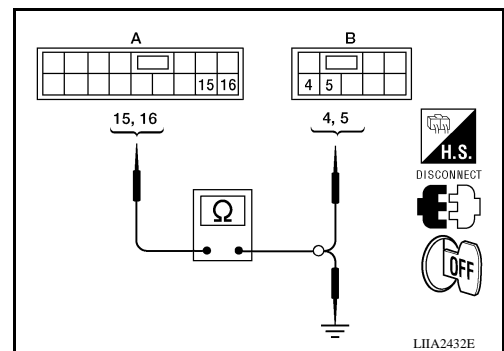

4. Check continuity between main power window and door lock/unlock switch connector (A) and ground.

Main power window and door lock/unlock switch connector	Terminal	Ground	Continuity
D7 (A)	15	Ground	No
	16		

Is the inspection result normal?

- YES >> Check intermittent incident. Refer to [GI-49, "Intermittent Incident"](#).
- NO >> Repair or replace harness.

### 3. CHECK HARNESS CONTINUITY (REAR POWER WINDOW SWITCH RH)

A  
B  
C  
D  
E  
F  
G  
H  
I  
J  
L  
M  
N  
O  
P

PWC

# POWER SUPPLY AND GROUND CIRCUIT

## < COMPONENT DIAGNOSIS >

1. Turn ignition switch OFF.
2. Disconnect main power window and door lock/unlock switch and rear power window switch RH.
3. Check continuity between main power window and door lock/unlock switch connector (A) and rear power window switch RH connector (B).

Main power window and door lock/unlock switch connector	Terminal	Rear power window switch RH connector	Terminal	Continuity
D7 (A)	8	D303 (B)	4	Yes
	9		5	

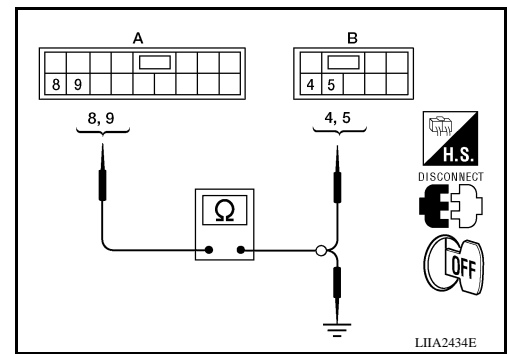

4. Check continuity between main power window and door lock/unlock switch connector (A) and ground.

Main power window and door lock/unlock switch connector	Terminal	Ground	Continuity
D7 (A)	8	Ground	No
	9		

Is the inspection result normal?

YES >> Check intermittent incident. Refer to [GI-49, "Intermittent Incident"](#).

NO >> Repair or replace harness.

## 4. CHECK HARNESS CONTINUITY

1. Disconnect BCM and rear power window switch.
2. Check continuity between BCM connector (A) and rear power window switch connector (B).

BCM connector	Terminal	Rear power window switch connector		Terminal	Continuity
M20 (A)	68	LH	D203 (B)	8	Yes
		RH	D303 (B)		

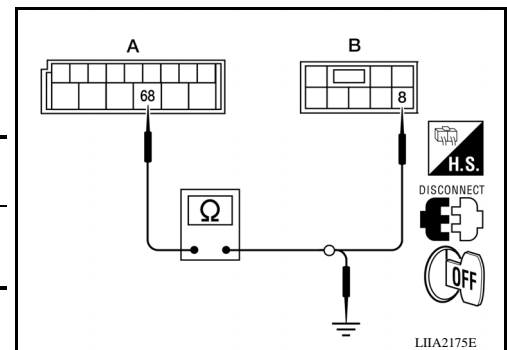

3. Check continuity between BCM connector (A) and ground.

BCM connector	Terminal	Ground	Continuity
M20 (A)	68	Ground	No

Is the inspection result normal?

YES >> GO TO 5

NO >> Repair or replace harness.

## 5. CHECK REAR POWER WINDOW SWITCH

Check rear power window switch.

Refer to [PWC-18, "REAR POWER WINDOW SWITCH : Component Inspection"](#).

Is the inspection result normal?

YES >> Check intermittent incident. Refer to [GI-49, "Intermittent Incident"](#).

NO >> Replace rear power window switch. Refer to [PWC-67, "Removal and Installation - Rear Door Switch \(if equipped\)"](#).

## REAR POWER WINDOW SWITCH : Component Inspection

INFOID:000000004056272

### COMPONENT INSPECTION

#### 1. CHECK REAR POWER WINDOW SWITCH

# POWER SUPPLY AND GROUND CIRCUIT

## < COMPONENT DIAGNOSIS >

Check rear power window switch.

	Terminals		Condition	Continuity
	Rear power window switch LH or RH	6	5	DOWN
NEUTRAL or UP				Yes
8		NEUTRAL or UP	No	
		DOWN	Yes	
7		4	UP	No
			NEUTRAL or DOWN	Yes
	8	NEUTRAL or DOWN	No	
		UP	Yes	

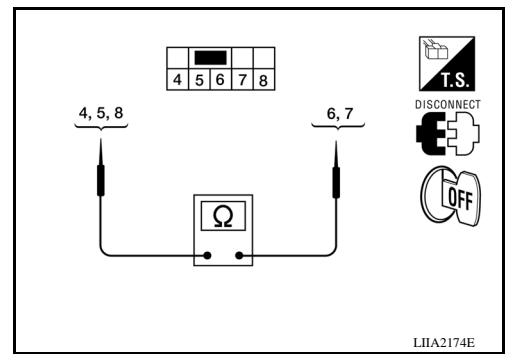

Is the inspection result normal?

YES >> Rear power window switch is OK.

NO >> Replace rear power window switch. Refer to [PWC-67, "Removal and Installation - Rear Door Switch \(if equipped\)"](#).

A  
B  
C  
D  
E  
F  
G  
H  
I  
J  
L  
M  
N  
O  
P

PWC

# POWER WINDOW MOTOR

< COMPONENT DIAGNOSIS >

## POWER WINDOW MOTOR DRIVER SIDE

### DRIVER SIDE : Description

INFOID:000000004056273

Door glass moves UP/DOWN by receiving the signal from power window main switch.

### DRIVER SIDE : Component Function Check

INFOID:000000004056274

#### 1. CHECK POWER WINDOW MOTOR CIRCUIT

Does front power window motor LH operate when operating main power window and door lock/unlock switch?  
Is the inspection result normal?

YES >> Front power window motor LH is OK.

NO >> Refer to [PWC-20. "DRIVER SIDE : Diagnosis Procedure"](#).

### DRIVER SIDE : Diagnosis Procedure

INFOID:000000004056275

#### Front Power Window Motor LH Circuit Check

##### 1. CHECK MAIN POWER WINDOW AND DOOR LOCK/UNLOCK SWITCH OUTPUT SIGNAL

1. Disconnect front power window motor LH.
2. Turn ignition switch ON.
3. Check voltage between front power window motor LH connector and ground.

Terminal (+)		Terminal (-)	Main power window and door lock/unlock switch condition	Voltage (V) (Approx.)
Power window motor LH connector	Terminal			
D9	2	Ground	UP	0
			DOWN	Battery voltage
	1		UP	Battery voltage
			DOWN	0

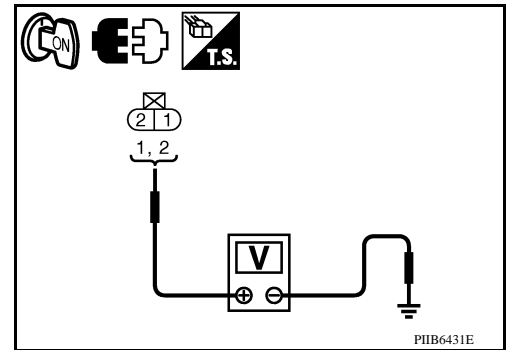

Is the measurement value within the specification?

YES >> GO TO 2

NO >> Replace main power window and door lock/unlock switch. Refer to [PWC-65. "Removal and Installation"](#).

##### 2. CHECK HARNESS CONTINUITY

1. Turn ignition switch OFF.
2. Disconnect main power window and door lock/unlock switch.
3. Check continuity between main power window and door lock/unlock switch connector and front power window motor connector LH.

Main power window and door lock/unlock switch connector	Terminal	Front power window motor LH connector	Terminal	Continuity
D7	6	D9	2	Yes
	7		1	

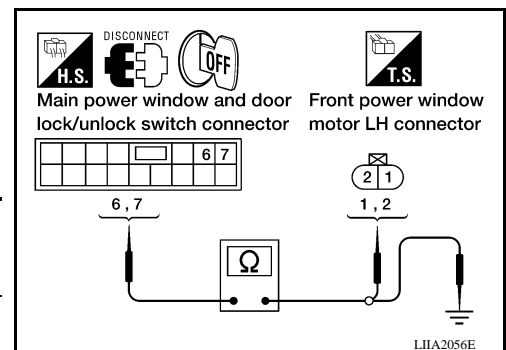

4. Check continuity between main power window and door lock/unlock switch connector (A) and ground.

# POWER WINDOW MOTOR

## < COMPONENT DIAGNOSIS >

Main power window and door lock/unlock switch connector	Terminal	Ground	Continuity
D7	6		No
	7		

Is the inspection result normal?

YES >> GO TO 3

NO >> Repair or replace harness.

### 3. CHECK POWER WINDOW MOTOR

Check front power window motor LH.

Refer to [PWC-21, "DRIVER SIDE : Component Inspection"](#).

Is the inspection result normal?

YES >> Check intermittent incident. Refer to [GI-49, "Intermittent Incident"](#).

NO >> Replace power window motor LH. Refer to [GW-16, "Front Door Glass Regulator"](#).

### DRIVER SIDE : Component Inspection

INFOID:000000004056276

#### COMPONENT INSPECTION

##### 1. CHECK FRONT POWER WINDOW MOTOR LH

Does motor operate by connecting the battery voltage directly to power window motor?

Terminal		Motor condition
(+)	(-)	
1	2	UP
2	1	DOWN

Is the inspection result normal?

YES >> Front power window motor LH is OK.

NO >> Replace front power window motor LH. Refer to [GW-16, "Front Door Glass Regulator"](#).

### PASSENGER SIDE

#### PASSENGER SIDE : Description

INFOID:000000004056277

Door glass moves UP/DOWN by receiving the signal from main power window and door lock/unlock switch or power window and door lock/unlock switch RH.

#### PASSENGER SIDE : Component Function Check

INFOID:000000004056278

##### 1. CHECK POWER WINDOW MOTOR CIRCUIT

Does power window motor operate when operating main power window and door lock/unlock switch or power window and door lock/unlock switch RH?

Is the inspection result normal?

YES >> Front power window motor RH is OK.

NO >> Refer to [PWC-21, "PASSENGER SIDE : Diagnosis Procedure"](#).

#### PASSENGER SIDE : Diagnosis Procedure

INFOID:000000004056279

Front Power Window Motor RH Circuit Check

##### 1. CHECK FRONT POWER WINDOW SWITCH RH OUTPUT SIGNAL

A  
B  
C  
D  
E  
F  
G  
H  
I  
J  
L  
M  
N  
O  
P

PWC

# POWER WINDOW MOTOR

## < COMPONENT DIAGNOSIS >

1. Disconnect front power window motor RH.
2. Turn ignition switch ON.
3. Check voltage between front power window motor RH connector and ground.

Terminal (+)		Terminal (-)	Front power window motor RH condition	Voltage (V) (Approx.)
Front power window motor RH connector	Terminal			
D104	2	Ground	UP	0
			DOWN	Battery voltage
	1		UP	Battery voltage
			DOWN	0

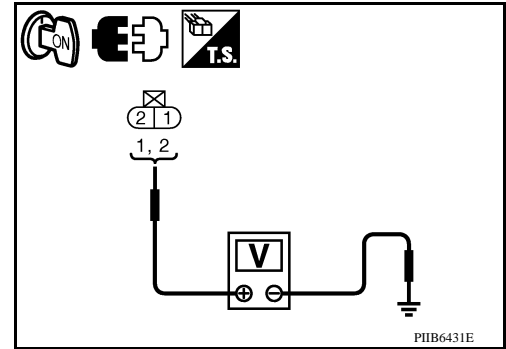

Is the measurement value within the specification?

YES >> GO TO 2

NO >> Replace power window and door lock/unlock switch RH. Refer to [PWC-66. "Removal and Installation"](#).

## 2. CHECK HARNESS CONTINUITY

1. Turn ignition switch OFF.
2. Disconnect power window and door lock/unlock switch RH.
3. Check continuity between power window and door lock/unlock switch RH connector and front power window motor RH connector.

Power window and door lock/unlock switch RH connector	Terminal	Front power window motor RH connector	Terminal	Continuity
D105	6	D104	1	Yes
	7		2	

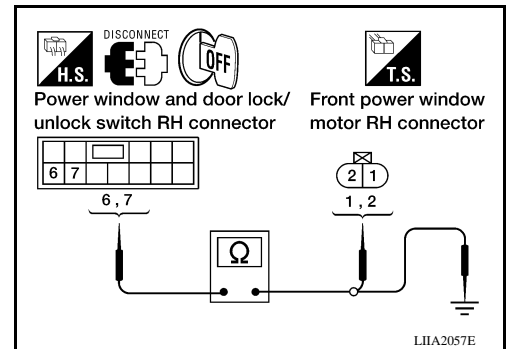

4. Check continuity between power window and door lock/unlock switch RH connector and ground.

Power window and door lock/unlock switch RH connector	Terminal	Ground	Continuity
D105	6	Ground	No
	7		

Is the inspection result normal?

YES >> GO TO 3

NO >> Repair or replace harness.

## 3. CHECK FRONT POWER WINDOW MOTOR RH

Check front power window motor RH.

Refer to [PWC-22. "PASSENGER SIDE : Component Inspection"](#).

Is the inspection result normal?

YES >> Check intermittent incident. Refer to [GI-49. "Intermittent Incident"](#).

NO >> Replace front power window motor RH. Refer to [GW-16. "Front Door Glass Regulator"](#).

## PASSENGER SIDE : Component Inspection

INFOID:000000004056280

### COMPONENT INSPECTION

#### 1. CHECK FRONT POWER WINDOW MOTOR RH

Does motor operate by connecting the battery voltage directly to front power window motor RH?

# POWER WINDOW MOTOR

## < COMPONENT DIAGNOSIS >

Terminal		Motor condition
(+)	(-)	
1	2	UP
2	1	DOWN

### Is the inspection result normal?

YES >> Front power window motor RH is OK.

NO >> Replace front power window motor RH. Refer to [GW-16. "Front Door Glass Regulator"](#).

## REAR LH

### REAR LH : Description

INFOID:000000004056281

Door glass moves UP/DOWN by receiving the signal from power window main switch or rear power window switch LH.

### REAR LH : Component Function Check

INFOID:000000004056282

#### 1. CHECK REAR POWER WINDOW MOTOR LH CIRCUIT

Does rear power window motor LH operate with main power window and door lock/unlock switch or rear power window switch LH?

### Is the inspection result normal?

YES >> Rear power window motor LH is OK.

NO >> Refer to [PWC-23. "REAR LH : Diagnosis Procedure"](#).

### REAR LH : Diagnosis Procedure

INFOID:000000004056283

#### Power Window Motor Circuit Check

#### 1. CHECK REAR POWER WINDOW SWITCH OUTPUT SIGNAL

1. Disconnect rear power window motor LH.
2. Turn ignition switch ON.
3. Check voltage between rear power window motor LH connector and ground.

Terminal		Window condition	Voltage (V) (Approx.)
(+)	(-)		
Rear power window motor LH connector  D204	1	UP	Battery voltage
		DOWN	0
	2	UP	0
		DOWN	Battery voltage

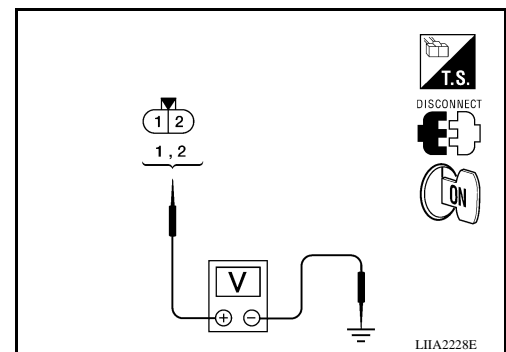

### Is the measurement value within the specification?

YES >> GO TO 2

NO >> Check rear power window switch LH. Refer to [PWC-17. "REAR POWER WINDOW SWITCH : Component Function Check"](#).

#### 2. CHECK HARNESS CONTINUITY

# POWER WINDOW MOTOR

## < COMPONENT DIAGNOSIS >

1. Turn ignition switch OFF.
2. Disconnect rear power window switch LH.
3. Check continuity between rear power window switch LH connector (A) and rear power window motor LH connector (B).

Rear power window switch LH connector	Terminal	Rear power window motor LH connector	Terminal	Continuity
D203 (A)	6	D204 (B)	1	Yes
	7		2	

4. Check continuity between rear power window switch LH connector (A) and ground.

Rear power window switch LH connector	Terminal	Ground	Continuity
D203 (A)	6	Ground	No
	7		

Is the inspection result normal?

- YES >> GO TO 3  
 NO >> Repair or replace harness.

### 3. CHECK REAR POWER WINDOW MOTOR LH

Check rear power window motor LH.

Refer to [PWC-24, "REAR LH : Component Inspection"](#).

Is the inspection result normal?

- YES >> Check intermittent incident. Refer to [GI-49, "Intermittent Incident"](#).  
 NO >> Replace rear power window motor LH. Refer to [GW-20, "Rear Door Glass Regulator"](#).

## REAR LH : Component Inspection

INFOID:000000004056284

### COMPONENT INSPECTION

#### 1. CHECK REAR POWER WINDOW MOTOR LH

Does motor operate by connecting the battery voltage directly to rear power window motor LH?

Terminal		Motor condition
(+)	(-)	
2	1	DOWN
1	2	UP

Is the inspection result normal?

- YES >> Rear power window motor LH is OK.  
 NO >> Replace rear power window motor LH. Refer to [GW-20, "Rear Door Glass Regulator"](#).

## REAR RH

### REAR RH : Description

INFOID:000000004056285

Door glass moves UP/DOWN by receiving the signal from main power window and door lock/unlock switch or rear power window switch RH.

### REAR RH : Component Function Check

INFOID:000000004056286

#### 1. CHECK REAR POWER WINDOW MOTOR RH CIRCUIT

Does rear power window motor RH operate with operating main power window and door lock/unlock switch or rear power window switch RH?

Is the inspection result normal?

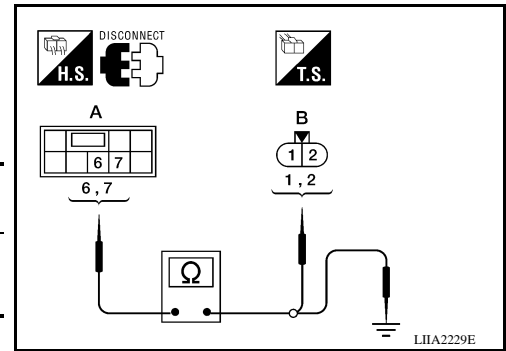



# POWER WINDOW MOTOR

## < COMPONENT DIAGNOSIS >

- YES >> Rear power window motor RH is OK.  
 NO >> Refer to [PWC-25, "REAR RH : Diagnosis Procedure"](#).

### REAR RH : Diagnosis Procedure

INFOID:000000004056287

#### Rear Power Window Motor RH Circuit Check

### 1. CHECK REAR POWER WINDOW SWITCH RH OUTPUT SIGNAL

1. Disconnect rear power window motor RH.
2. Turn ignition switch ON.
3. Check voltage between rear power window motor RH connector and ground.

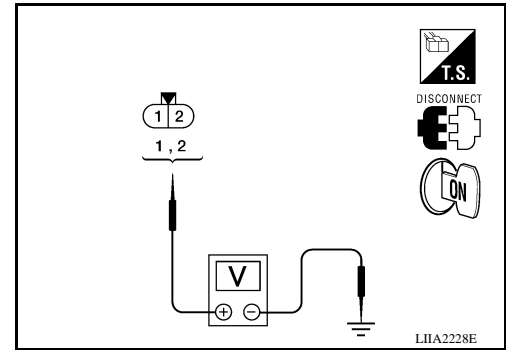

Terminal (+)		Terminal (-)	Rear power window switch RH condition	Voltage (V) (Approx.)
Rear power window motor RH connector	Terminal			
D304	1	Ground	UP	Battery voltage
			DOWN	0
	2		UP	0
			DOWN	Battery voltage

Is the measurement value within the specification?

- YES >> GO TO 2  
 NO >> Check rear power window switch RH. Refer to [PWC-17, "REAR POWER WINDOW SWITCH : Component Function Check"](#).

### 2. CHECK HARNESS CONTINUITY

1. Turn ignition switch OFF.
2. Disconnect rear power window switch RH.
3. Check continuity between rear power window switch RH connector (A) and rear power window motor RH connector (B).

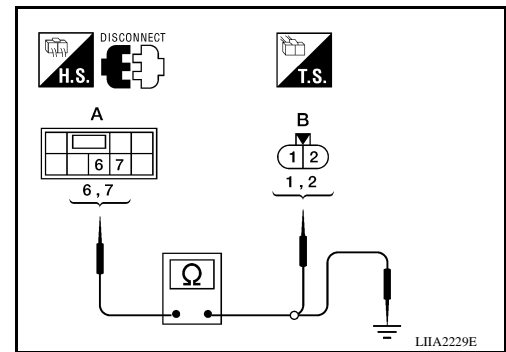

Rear power window switch RH connector	Terminal	Rear power window motor RH connector	Terminal	Continuity
D303 (A)	6	D304 (B)	1	Yes
	7		2	

4. Check continuity between rear power window switch RH connector (A) and ground.

Rear power window switch RH connector	Terminal	Ground	Continuity
D303 (A)	6	Ground	No
	7		

Is the inspection result normal?

- YES >> GO TO 3  
 NO >> Repair or replace harness.

### 3. CHECK REAR POWER WINDOW MOTOR RH

Check rear power window motor RH.  
 Refer to [PWC-26, "REAR RH : Component Inspection"](#).

Is the inspection result normal?

- YES >> Check intermittent incident. Refer to [GI-49, "Intermittent Incident"](#).  
 NO >> Replace rear power window motor RH. Refer to [GW-20, "Rear Door Glass Regulator"](#).

A  
B  
C  
D  
E  
F  
G  
H  
I  
J  
L  
M  
N  
O  
P

PWC

# POWER WINDOW MOTOR

< COMPONENT DIAGNOSIS >

REAR RH : Component Inspection

INFOID:000000004056288

COMPONENT INSPECTION

## 1. CHECK REAR POWER WINDOW MOTOR RH

Does motor operate by connecting the battery voltage directly to rear power window motor RH?

Terminal		Motor condition
(+)	(-)	
2	1	DOWN
1	2	UP

Is the inspection result normal?

YES >> Rear power window motor RH is OK.

NO >> Replace rear power window motor RH. Refer to [GW-20, "Rear Door Glass Regulator"](#).

# DOOR SWITCH

< COMPONENT DIAGNOSIS >

## DOOR SWITCH

### KING CAB

#### KING CAB : Description

INFOID:000000004056289

Detects door open/close condition.

#### KING CAB : Component Function Check

INFOID:000000004056290

### 1. CHECK FUNCTION

#### With CONSULT-III

Check door switches in data monitor mode with CONSULT-III.

Monitor item	Condition
DOOR SW-DR	CLOSE → OPEN: OFF → ON
DOOR SW-AS	

Is the inspection result normal?

YES >> Door switch is OK.

NO >> Refer to [PWC-27, "KING CAB : Diagnosis Procedure"](#).

#### KING CAB : Diagnosis Procedure

INFOID:000000004056291

### 1. CHECK DOOR SWITCHES INPUT SIGNAL

#### With CONSULT-III

Check door switches ("DOOR SW-DR", "DOOR SW-AS") in DATA MONITOR mode with CONSULT-III. Refer to [BCS-15, "DOOR LOCK : CONSULT-III Function \(BCM - DOOR LOCK\)"](#).

• When any doors are open:

**DOOR SW-DR :ON**

**DOOR SW-AS :ON**

• When any doors are closed:

**DOOR SW-DR :OFF**

**DOOR SW-AS :OFF**

#### Without CONSULT-III

Check voltage between BCM connector M18 or M19 terminals 12, 47 and ground.

Connector	Item	Terminals		Condition	Voltage (V) (Approx.)
		(+)	(-)		
M19	Door switches LH	47	Ground	Open ↓ Closed	0 ↓ Battery voltage
M18	Door switches RH	12			

Is the inspection result normal?

YES >> Door switch circuit is OK.

NO >> GO TO 2

### 2. CHECK BCM OUTPUT VOLTAGE

1. Turn ignition switch OFF.
2. Disconnect door switches.

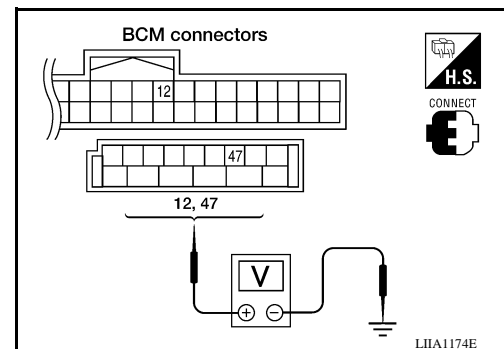

# DOOR SWITCH

## < COMPONENT DIAGNOSIS >

3. Check voltage between BCM connector M18, M19 terminals 12, 47 and ground.

**12 - Ground : Battery voltage**  
**47 - Ground : Battery voltage**

Is the inspection result normal?

- YES >> GO TO 3  
 NO >> Replace BCM. Refer to [BCS-56, "Removal and Installation"](#).

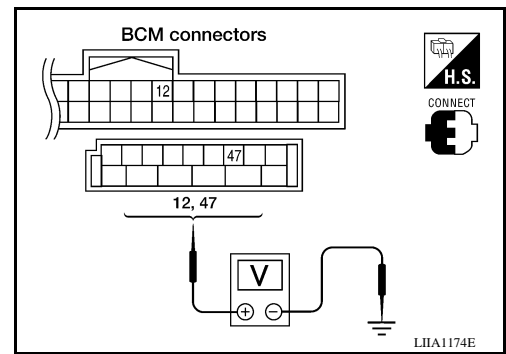

### 3. CHECK DOOR SWITCH CIRCUIT

1. Disconnect BCM.
2. Check continuity between door switch connector D213 (Front LH), D314 (Front RH) terminal 2, D211 (Rear upper LH), D312 (Rear upper RH), D212 (Rear lower LH), D313 (Rear lower RH) terminal 1 and BCM connector M18, M19 terminals 12, and 47.

**2 - 47 : Continuity should exist**  
**2 - 12 : Continuity should exist**  
**1 - 47 : Continuity should exist**  
**1 - 12 : Continuity should exist**

3. Check continuity between door switch connector D213 (Front LH), D314 (Front RH) terminal 2, D211 (Rear upper LH), D312 (Rear upper RH), D212 (Rear lower LH), D313 (Rear lower RH) terminal 1 and ground.

**2 - Ground : Continuity should not exist**  
**1 - Ground : Continuity should not exist**

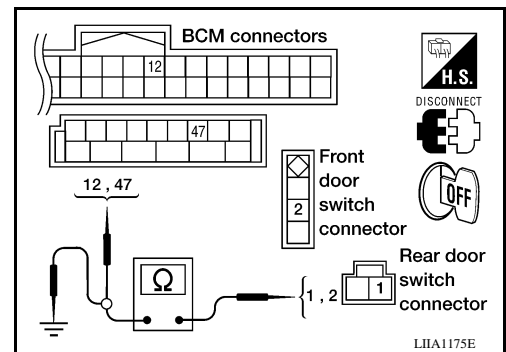

Is the inspection result normal?

- YES >> GO TO 4  
 NO >> Repair or replace harness.

### 4. CHECK DOOR SWITCHES GROUND CIRCUIT

Check continuity between door switch connector D213 (Front LH), D314 (Front RH) terminal 3, D211 (Rear upper LH), D312 (Rear upper RH), D212 (Rear lower LH), D313 (Rear lower RH) terminal 2 and ground.

**3 - Ground : Continuity should not exist**  
**2 - Ground : Continuity should not exist**

Is the inspection result normal?

- YES >> GO TO 5  
 NO >> Repair or replace harness.

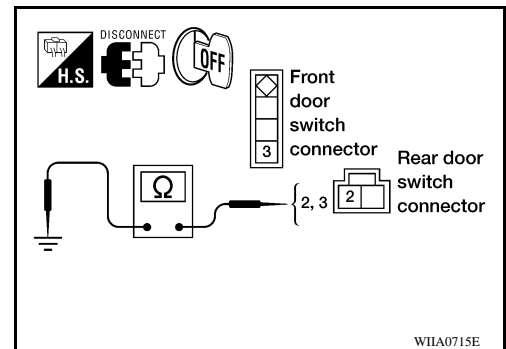

### 5. CHECK DOOR SWITCHES

Check continuity between door switch terminals.

# DOOR SWITCH

## < COMPONENT DIAGNOSIS >

Item	Terminal	Condition	Continuity
Door switches (front)	2 - 3	Open	Yes
		Closed	No
Door switches (rear upper and lower)	1 - 2	Open	Yes
		Closed	No

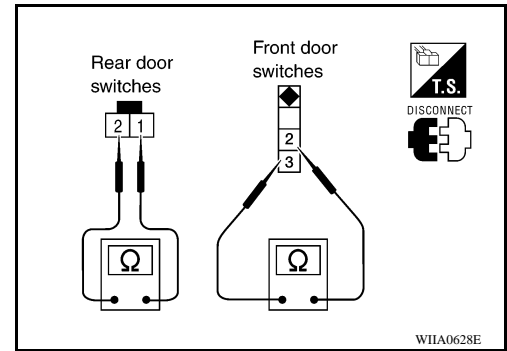

Is the inspection result normal?

- YES >> Check condition of harness and connector.
- NO >> Replace door switch.

## CREW CAB

### CREW CAB : Description

INFOID:000000004056292

Detects door open/close condition.

### CREW CAB : Component Function Check

INFOID:000000004056293

#### 1. CHECK FUNCTION

##### With CONSULT-III

Check door switches in data monitor mode with CONSULT-III.

Monitor item	Condition
DOOR SW-DR	CLOSE → OPEN: OFF → ON
DOOR SW-AS	

Is the inspection result normal?

- YES >> Door switch is OK.
- NO >> Refer to [PWC-29. "CREW CAB : Diagnosis Procedure"](#).

## CREW CAB : Diagnosis Procedure

INFOID:000000004056294

#### 1. CHECK DOOR SWITCHES INPUT SIGNAL

##### With CONSULT-III

Check door switches ("DOOR SW-DR", "DOOR SW-AS") in DATA MONITOR mode with CONSULT-III. Refer to [BCS-15. "DOOR LOCK : CONSULT-III Function \(BCM - DOOR LOCK\)"](#).

- When any doors are open:

**DOOR SW-DR : ON**

**DOOR SW-AS : ON**

- When any doors are closed:

**DOOR SW-DR : OFF**

**DOOR SW-AS : OFF**

##### Without CONSULT-III

A  
B  
C  
D  
E  
F  
G  
H  
I  
J  
L  
M  
N  
O  
P

PWC

# DOOR SWITCH

## < COMPONENT DIAGNOSIS >

Check voltage between BCM connector M18 or M19 terminals 12, 47 and ground.

Connector	Item	Terminals		Condition	Voltage (V) (Approx.)
		(+)	(-)		
M19	Front door switch LH	47	Ground	Open ↓ Closed	0 ↓ Battery voltage
M18	Front door switch RH	12			

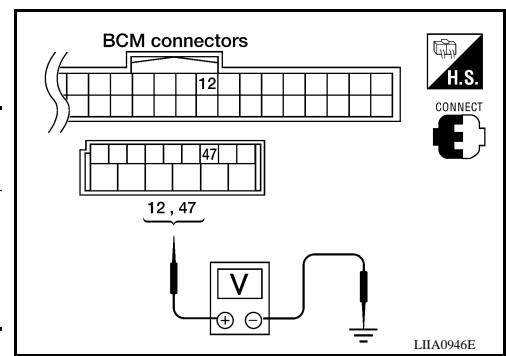

Is the inspection result normal?

- YES >> Door switch circuit is OK.
- NO >> GO TO 2

## 2. CHECK BCM OUTPUT VOLTAGE

- Turn ignition switch OFF.
- Disconnect door switches.
- Check voltage between BCM connector M18, M19 terminals 12, 47 and ground.

**12 - Ground : Battery voltage**  
**47 - Ground : Battery voltage**

Is the inspection result normal?

- YES >> GO TO 3
- NO >> Replace BCM. Refer to [BCS-56. "Removal and Installation"](#).

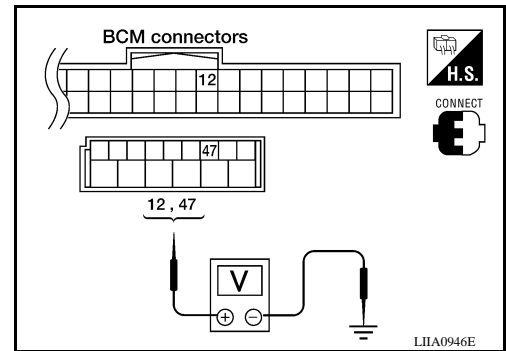

## 3. CHECK DOOR SWITCH CIRCUIT

- Disconnect door switch and BCM.
- Check continuity between door switch connector B8 (Front LH), B108 (Front RH) terminal 2 and BCM connector M18, M19 terminals 12, and 47.

**2 - 47 : Continuity should exist.**  
**2 - 12 : Continuity should exist.**

- Check continuity between door switch connector B8 (Front LH), B108 (Front RH) terminal 2 and ground.

**2 - Ground : Continuity should not exist.**

Is the inspection result normal?

- YES >> GO TO 4
- NO >> Repair or replace harness.

## 4. CHECK DOOR SWITCHES

- Disconnect door switch.
- Check continuity between door switch terminals.

Terminal	Condition	Continuity
2	Open	Yes
	Closed	No

Is the inspection result normal?

- YES >> Check switch case ground condition.
- NO >> Replace door switch.

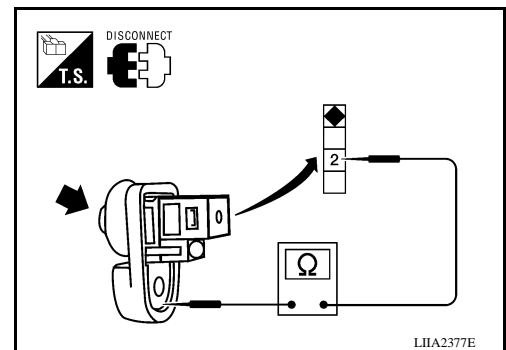
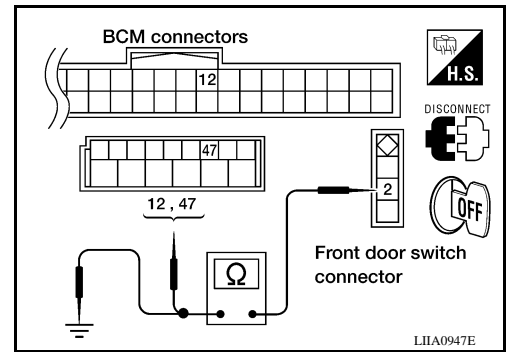

# POWER WINDOW LOCK SWITCH

< COMPONENT DIAGNOSIS >

## POWER WINDOW LOCK SWITCH

### Description

INFOID:000000004056295

Ground circuit of main power window and door lock/unlock switch shuts off if power window lock switch of main power window and door lock/unlock switch is operated. This inhibits all operation, except for the main switch.

### Component Function Check

INFOID:000000004056296

#### 1. CHECK POWER WINDOW LOCK SIGNAL

Exchanges for a normal main power window and door lock/unlock switch, and operation is checked.

##### Does power window lock operate?

- YES >> Replace main power window and door lock/unlock switch. Refer to [PWC-65. "Removal and Installation"](#).
- NO >> Check condition of harness and connector.

A  
B  
C  
D  
E  
F  
G  
H  
I  
J  
L  
M  
N  
O  
P

PWC

# BCM (BODY CONTROL MODULE)

< ECU DIAGNOSIS >

## ECU DIAGNOSIS

### BCM (BODY CONTROL MODULE)

Reference Value

INFOID:000000004449414

#### VALUES ON THE DIAGNOSIS TOOL

Monitor Item	Condition	Value/Status
IGN ON SW	Ignition switch OFF or ACC	OFF
	Ignition switch ON	ON
KEY ON SW	Mechanical key is removed from key cylinder	OFF
	Mechanical key is inserted to key cylinder	ON
CDL LOCK SW	Door lock/unlock switch does not operate	OFF
	Press door lock/unlock switch to the lock side	ON
CDL UNLOCK SW	Door lock/unlock switch does not operate	OFF
	Press door lock/unlock switch to the unlock side	ON
DOOR SW-DR	Driver's door closed	OFF
	Driver's door opened	ON
DOOR SW-AS	Passenger door closed	OFF
	Passenger door opened	ON
DOOR SW-RR	Rear RH door closed	OFF
	Rear RH door opened	ON
DOOR SW-RL	Rear LH door closed	OFF
	Rear LH door opened	ON
BACK DOOR SW	<b>NOTE:</b> The item is indicated, but not monitored.	—
KEY CYL LK-SW	Other than driver door key cylinder LOCK position	OFF
	Driver door key cylinder LOCK position	ON
KEY CYL UN-SW	Other than driver door key cylinder UNLOCK position	OFF
	Driver door key cylinder UNLOCK position	ON
KEYLESS LOCK	"LOCK" button of key fob is not pressed	OFF
	"LOCK" button of key fob is pressed	ON
KEYLESS UNLOCK	"UNLOCK" button of key fob is not pressed	OFF
	"UNLOCK" button of key fob is pressed	ON
ACC ON SW	Ignition switch OFF	OFF
	Ignition switch ACC or ON	ON
REAR DEF SW	Rear window defogger switch OFF	OFF
	Rear window defogger switch ON	ON
LIGHT SW 1ST	Lighting switch OFF	OFF
	Lighting switch 1ST	ON
BUCKLE SW	The seat belt (driver side) is unfastened. [Seat belt switch (driver side) OFF]	OFF
	The seat belt (driver side) is fastened. [Seat belt switch (driver side) ON]	ON
KEYLESS PANIC	PANIC button of key fob is not pressed	OFF
	PANIC button of key fob is pressed	ON



## BCM (BODY CONTROL MODULE)

### < ECU DIAGNOSIS >

Monitor Item	Condition	Value/Status	
KEYLESS TRUNK	<b>NOTE:</b> The item is indicated, but not monitored.	OFF	A
TRNK OPN MNTR	<b>NOTE:</b> The item is indicated, but not monitored.	OFF	B
RKE LCK-UNLCK	LOCK/UNLOCK button of key fob is not pressed and held simultaneously	OFF	C
	LOCK/UNLOCK button of key fob is pressed and held simultaneously	ON	
RKE KEEP UNLK	UNLOCK button of key fob is not pressed	OFF	D
	UNLOCK button of key fob is pressed and held	ON	
HI BEAM SW	Lighting switch OFF	OFF	E
	Lighting switch HI	ON	
HEAD LAMP SW 1	Lighting switch OFF	OFF	F
	Lighting switch 2ND	ON	
HEAD LAMP SW 2	Lighting switch OFF	OFF	F
	Lighting switch 2ND	ON	
AUTO LIGHT SW	Lighting switch OFF	OFF	G
	Lighting switch AUTO	ON	
PASSING SW	Other than lighting switch PASS	OFF	H
	Lighting switch PASS	ON	
FR FOG SW	Front fog lamp switch OFF	OFF	I
	Front fog lamp switch ON	ON	
RR FOG SW	<b>NOTE:</b> The item is indicated, but not monitored.	OFF	I
TURN SIGNAL R	Turn signal switch OFF	OFF	J
	Turn signal switch RH	ON	
TURN SIGNAL L	Turn signal switch OFF	OFF	J
	Turn signal switch LH	ON	
CARGO LAMP SW	Cargo lamp switch OFF	OFF	L
	Cargo lamp switch ON	ON	
OPTICAL SENSOR	Bright outside vehicle	5V	L
	Dark outside vehicle	0V	
IGN SW CAN	Ignition switch OFF or ACC	OFF	M
	Ignition switch ON	ON	
FR WIPER HI	Front wiper switch OFF	OFF	N
	Front wiper switch HI	ON	
FR WIPER LOW	Front wiper switch OFF	OFF	O
	Front wiper switch LO	ON	
FR WIPER INT	Front wiper switch OFF	OFF	O
	Front wiper switch INT	ON	
FR WASHER SW	Front washer switch OFF	OFF	P
	Front washer switch ON	ON	
INT VOLUME	Wiper intermittent dial is in a dial position 1 - 7	1 - 7	
FR WIPER STOP	Any position other than front wiper stop position	OFF	
	Front wiper stop position	ON	
VEHICLE SPEED	While driving	Equivalent to speedometer reading	

A

B

C

D

E

F

G

H

I

J

PWC

L

M

N

O

P

## BCM (BODY CONTROL MODULE)

### < ECU DIAGNOSIS >

Monitor Item	Condition	Value/Status
RR WIPER ON	<b>NOTE:</b> The item is indicated, but not monitored.	OFF
RR WIPER INT	<b>NOTE:</b> The item is indicated, but not monitored.	OFF
RR WASHER SW	<b>NOTE:</b> The item is indicated, but not monitored.	OFF
RR WIPER STOP	<b>NOTE:</b> The item is indicated, but not monitored.	OFF
RR WIPER STP2	<b>NOTE:</b> The item is indicated, but not monitored.	OFF
H/L WASH SW	<b>NOTE:</b> The item is indicated, but not monitored.	OFF
HAZARD SW	Hazard switch OFF	OFF
	Hazard switch ON	ON
BRAKE SW	Brake pedal is not depressed	OFF
	Brake pedal is depressed	ON
FAN ON SIG	Blower fan motor switch OFF	OFF
	Blower fan motor switch ON (other than OFF)	ON
AIR COND SW	Compressor ON is not requested from auto amp. (A/C indicator OFF, blower fan motor switch OFF or etc.)	OFF
	Compressor ON is requested from auto amp. (A/C indicator ON and blower fan motor switch ON).	ON
TRNK OPNR SW	<b>NOTE:</b> The item is indicated, but not monitored.	OFF
TRUNK CYL SW	<b>NOTE:</b> The item is indicated, but not monitored.	OFF
HOOD SW	<b>NOTE:</b> The item is indicated, but not monitored.	OFF
OIL PRESS SW	<ul style="list-style-type: none"> <li>• Ignition switch OFF or ACC</li> <li>• Engine running</li> </ul>	OFF
	Ignition switch ON	ON
AIR PRESS FL	Ignition switch ON (Only when the signal from the transmitter is received)	Air pressure of front LH tire
AIR PRESS FR	Ignition switch ON (Only when the signal from the transmitter is received)	Air pressure of front RH tire
AIR PRESS RR	Ignition switch ON (Only when the signal from the transmitter is received)	Air pressure of rear RH tire
AIR PRESS RL	Ignition switch ON (Only when the signal from the transmitter is received)	Air pressure of rear LH tire
ID REGST FL1	ID of front LH tire transmitter is registered	DONE
	ID of front LH tire transmitter is not registered	YET
ID REGST FR1	ID of front RH tire transmitter is registered	DONE
	ID of front RH tire transmitter is not registered	YET
ID REGST RR1	ID of rear RH tire transmitter is registered	DONE
	ID of rear RH tire transmitter is not registered	YET
ID REGST RL1	ID of rear LH tire transmitter is registered	DONE
	ID of rear LH tire transmitter is not registered	YET
WARNING LAMP	Tire pressure indicator OFF	OFF
	Tire pressure indicator ON	ON

# BCM (BODY CONTROL MODULE)

## < ECU DIAGNOSIS >

Monitor Item	Condition	Value/Status
BUZZER	Tire pressure warning alarm is not sounding	OFF
	Tire pressure warning alarm is sounding	ON

## Terminal Layout

INFOID:000000004449415

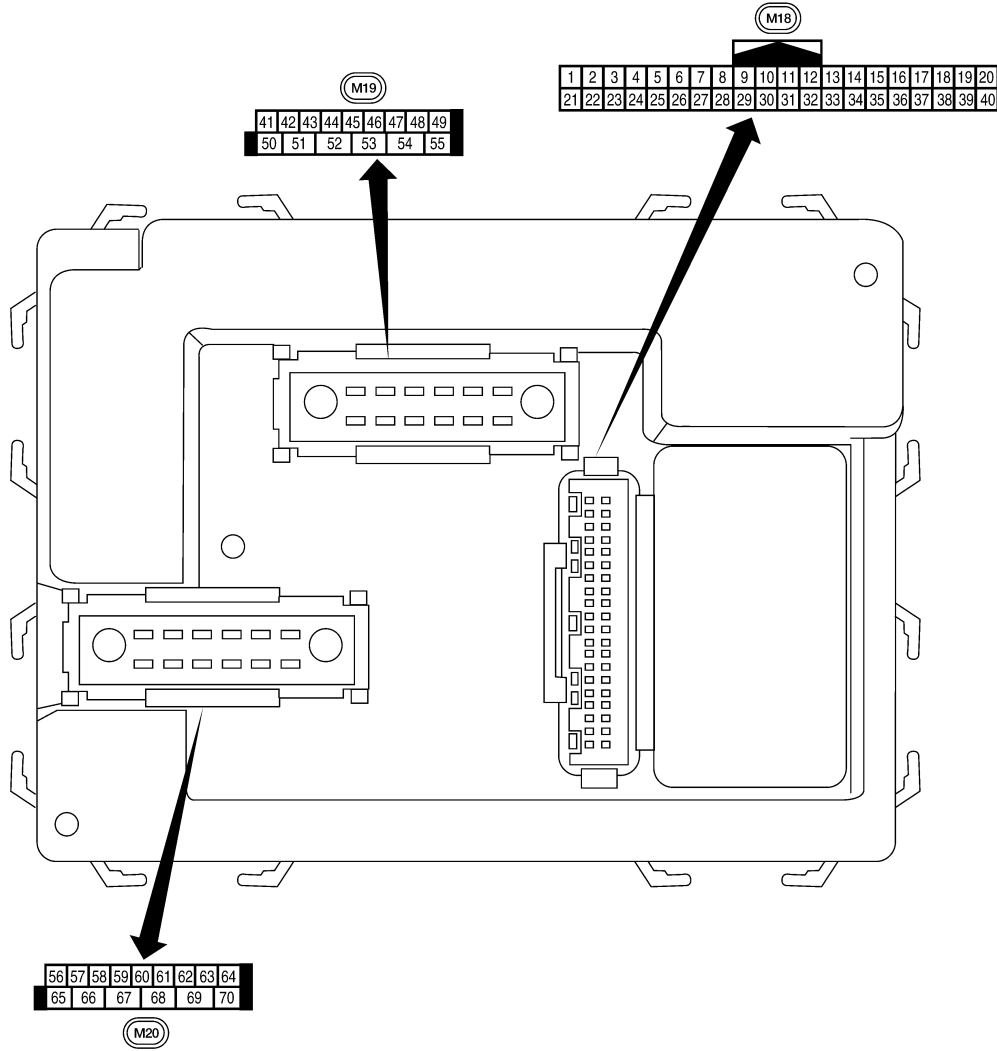

A  
B  
C  
D  
E  
F  
G  
H  
I  
J  
L  
M  
N  
O  
P

PWC

# BCM (BODY CONTROL MODULE)

< ECU DIAGNOSIS >

## Physical Values

INFOID:000000004449416

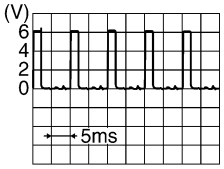
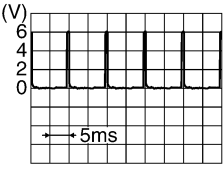
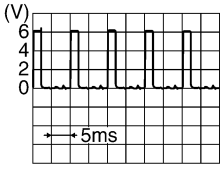
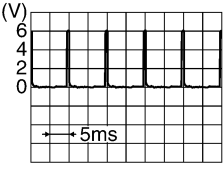
Terminal	Wire color	Item	Signal input/output	Measuring condition		Reference value or waveform (Approx.)
				Ignition switch	Operation or condition	
1	BR	Ignition keyhole illumination	Output	OFF	Door is locked (SW OFF)	Battery voltage
					Door is unlocked (SW ON)	0V
2	P	Combination switch input 5	Input	ON	Lighting, turn, wiper OFF Wiper dial position 4	 <p style="text-align: right; font-size: small;">SKIA5291E</p>
3	SB	Combination switch input 4	Input	ON	Lighting, turn, wiper OFF Wiper dial position 4	 <p style="text-align: right; font-size: small;">SKIA5292E</p>
4	V	Combination switch input 3	Input	ON	Lighting, turn, wiper OFF Wiper dial position 4	 <p style="text-align: right; font-size: small;">SKIA5291E</p>
5	L	Combination switch input 2	Input	ON	Lighting, turn, wiper OFF Wiper dial position 4	 <p style="text-align: right; font-size: small;">SKIA5292E</p>
6	R	Combination switch input 1				
7	GR	Front door lock assembly LH (key cylinder switch) unlock	Input	OFF	ON (open, 2nd turn)	Momentary 1.5V
8	SB	Front door lock assembly LH (key cylinder switch) lock			On (open)	Momentary 1.5V
			OFF (closed)	0V		
9	Y	Rear window defogger switch	Input	ON	Rear window defogger switch ON	0V
					Rear window defogger switch OFF	5V
11	G/B	Ignition switch (ACC or ON)	Input	ACC or ON	Ignition switch ACC or ON	Battery voltage

# BCM (BODY CONTROL MODULE)

## < ECU DIAGNOSIS >

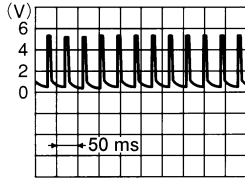
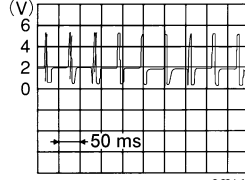
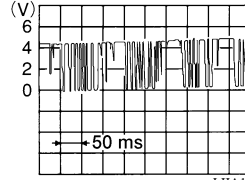
Terminal	Wire color	Item	Signal input/output	Measuring condition		Reference value or waveform (Approx.)
				Ignition switch	Operation or condition	
12	LG	Front door switch RH (All)	Input	OFF	ON (open)	0V
		Rear door switch upper RH (King Cab)			OFF (closed)	Battery voltage
		Rear door switch lower RH (King Cab)				
13	L	Rear door switch RH (Crew Cab)	Input	OFF	ON (open)	0V
					OFF (closed)	Battery voltage
15	W	Tire pressure warning check connector	Input	OFF	—	5V
18	BR	Remote keyless entry receiver (Ground)	Output	OFF	—	0V
19	V	Remote keyless entry receiver (power supply)	Output	OFF	Ignition switch OFF	
20	G	Remote keyless entry receiver signal (Signal)	Input	OFF	Stand-by (keyfob buttons released)	
					When remote keyless entry receiver receives signal from keyfob (keyfob buttons pressed)	
21	GR	NATS antenna amp.	Input	OFF → ON	Ignition switch (OFF → ON)	Just after turning ignition switch ON: Pointer of tester should move.
23	G	Security indicator lamp	Output	OFF	Goes OFF → illuminates (Every 2.4 seconds)	Battery voltage → 0V
25	BR	NATS antenna amp.	Input	OFF → ON	Ignition switch (OFF → ON)	Just after turning ignition switch ON: Pointer of tester should move.
27	W	Compressor ON signal	Input	ON	A/C switch OFF	5V
					A/C switch ON	0V
28	R	Front blower monitor	Input	ON	Front blower motor OFF	Battery voltage
					Front blower motor ON	0V
29	G	Hazard switch	Input	OFF	ON	0V
					OFF	5V

A  
B  
C  
D  
E  
F  
G  
H  
I  
J  
L  
M  
N  
O  
P

PWC

# BCM (BODY CONTROL MODULE)

## < ECU DIAGNOSIS >

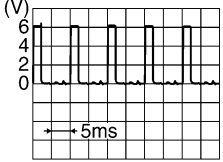
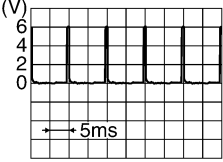
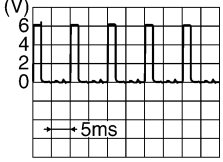
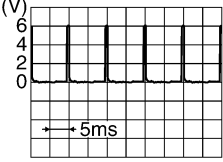
Terminal	Wire color	Item	Signal input/output	Measuring condition		Reference value or waveform (Approx.)
				Ignition switch	Operation or condition	
31	GR	Cargo lamp switch	Input	OFF	ON	0V
				OFF	OFF	Battery voltage
32	O	Combination switch output 5	Output	ON	Lighting, turn, wiper OFF Wiper dial position 4	 SKIA5291E
33	GR	Combination switch output 4	Output	ON	Lighting, turn, wiper OFF Wiper dial position 4	 SKIA5292E
34	G	Combination switch output 3	Output	ON	Lighting, turn, wiper OFF Wiper dial position 4	 SKIA5291E
35	BR	Combination switch output 2	Output	ON	Lighting, turn, wiper OFF Wiper dial position 4	 SKIA5292E
36	LG	Combination switch output 1				
37	B	Key switch	Input	OFF	Key inserted	Battery voltage
				OFF	Key removed	0V
38	W/R	Ignition switch (ON)	Input	ON	—	Battery voltage
39	L	CAN-H	—	—	—	—
40	P	CAN-L	—	—	—	—
45	V	Lock switch	Input	OFF	ON (lock)	0V
				OFF	OFF	Battery voltage
46	LG	Unlock switch	Input	OFF	ON (unlock)	0V
				OFF	OFF	Battery voltage
47	GR	Front door switch LH (All)	Input	OFF	ON (open)	0V
		Rear door switch upper LH (King Cab)			OFF (closed)	Battery voltage
		Rear door switch lower LH (King Cab)				
48	P	Rear door switch LH (Crew Cab)	Input	OFF	ON (open)	0V
				OFF	OFF (closed)	Battery voltage

# BCM (BODY CONTROL MODULE)

## < ECU DIAGNOSIS >

Terminal	Wire color	Item	Signal input/output	Measuring condition		Reference value or waveform (Approx.)	
				Ignition switch	Operation or condition		
50	P	Cargo lamp	Output	OFF	Any door open (ON)	0V	
					All doors closed (OFF)	Battery voltage	
51	G	Trailer turn signal (right)	Output	ON	Turn right ON	<p style="text-align: right; font-size: small;">SKIA3009J</p>	
52	V	Trailer turn signal (left)	Output	ON	Turn left ON	<p style="text-align: right; font-size: small;">SKIA3009J</p>	
56	V	Battery saver output	Output	OFF	30 minutes after ignition switch is turned OFF	0V	
				ON	—	Battery voltage	
57	R/Y	Battery power supply	Input	—	—	Battery voltage	
58	W	Optical sensor	Input	ON	When optical sensor is illuminated	3.1V or more	
					When optical sensor is not illuminated	0.6V or less	
59	GR	Front door lock assembly LH (unlock)	Output	OFF	OFF (neutral)	0V	
					ON (unlock)	Battery voltage	
60	LG	Turn signal (left)	Output	ON	Turn left ON	<p style="text-align: right; font-size: small;">SKIA3009J</p>	
61	G	Turn signal (right)	Output	ON	Turn right ON	<p style="text-align: right; font-size: small;">SKIA3009J</p>	
63	BR	Interior room/map lamp	Output	OFF	Any door switch	ON (open)	0V
					OFF (closed)	Battery voltage	
65	V	All door lock actuators (lock)	Output	OFF	OFF (neutral)	0V	
					ON (lock)	Battery voltage	
66	L	Front door lock actuator RH, rear door lock actuators LH/RH (unlock)	Output	OFF	OFF (neutral)	0V	
					ON (unlock)	Battery voltage	

A  
B  
C  
D  
E  
F  
G  
H  
I  
J

PWC

L  
M  
N  
O

P

## BCM (BODY CONTROL MODULE)

### < ECU DIAGNOSIS >

Terminal	Wire color	Item	Signal input/output	Measuring condition		Reference value or waveform (Approx.)
				Ignition switch	Operation or condition	
67	B	Ground	Input	ON	—	0V
68	O	Power window power supply (RAP)	Output	—	Ignition switch ON	Battery voltage
					Within 45 seconds after ignition switch OFF	Battery voltage
					More than 45 seconds after ignition switch OFF	0V
					When front door LH or RH is open or power window timer operates	0V
69	P	Power window power supply (BAT)	Output	OFF	—	Battery voltage
70	W	Battery power supply	Input	OFF	—	Battery voltage



# BCM (BODY CONTROL MODULE)

< ECU DIAGNOSIS >

## Wiring Diagram

INFOID:000000004449417

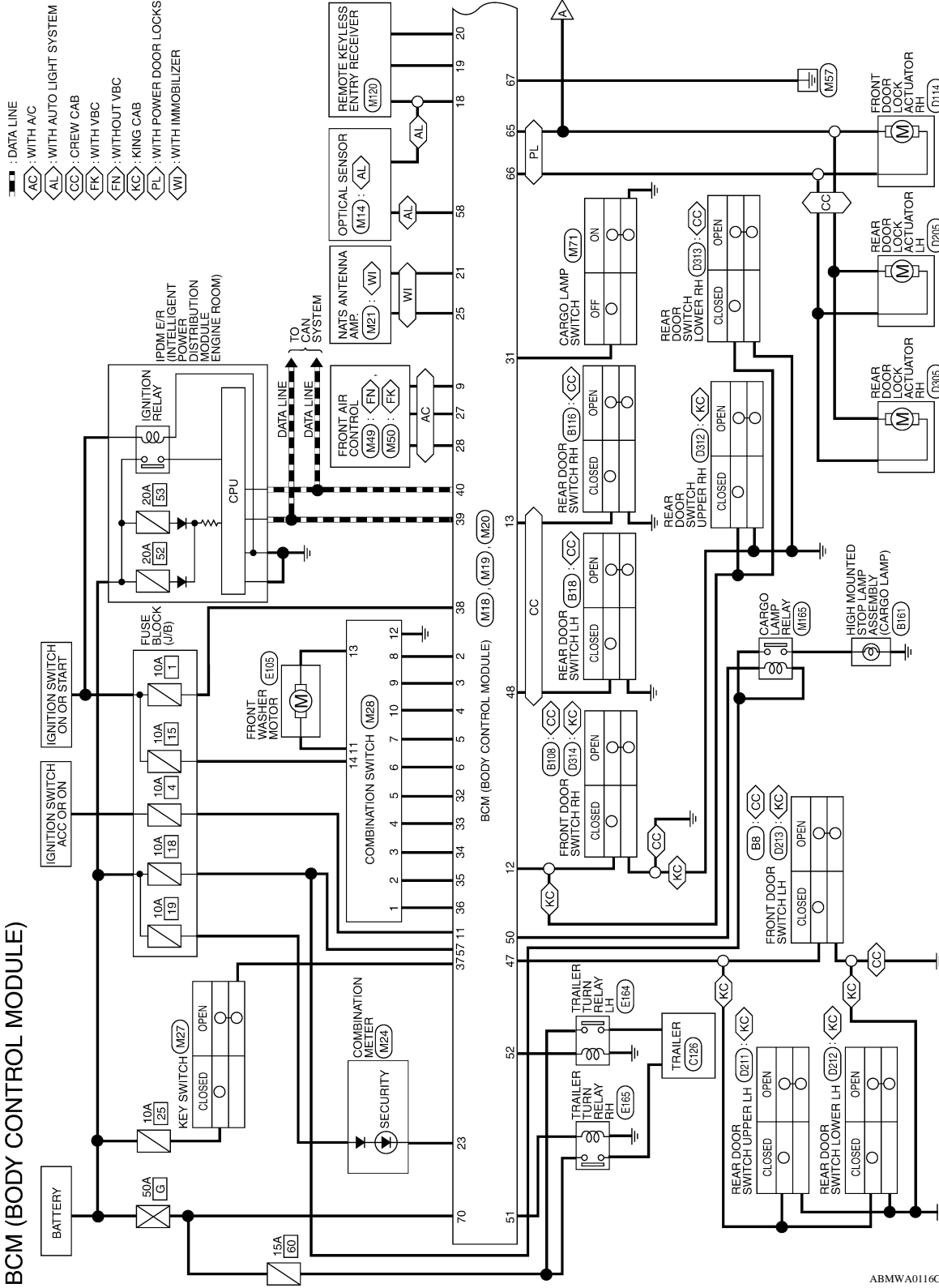

ABMWA0116GI

A  
B  
C  
D  
E  
F  
G  
H  
I  
J  
K  
L  
M  
N  
O  
P



# BCM (BODY CONTROL MODULE)

< ECU DIAGNOSIS >

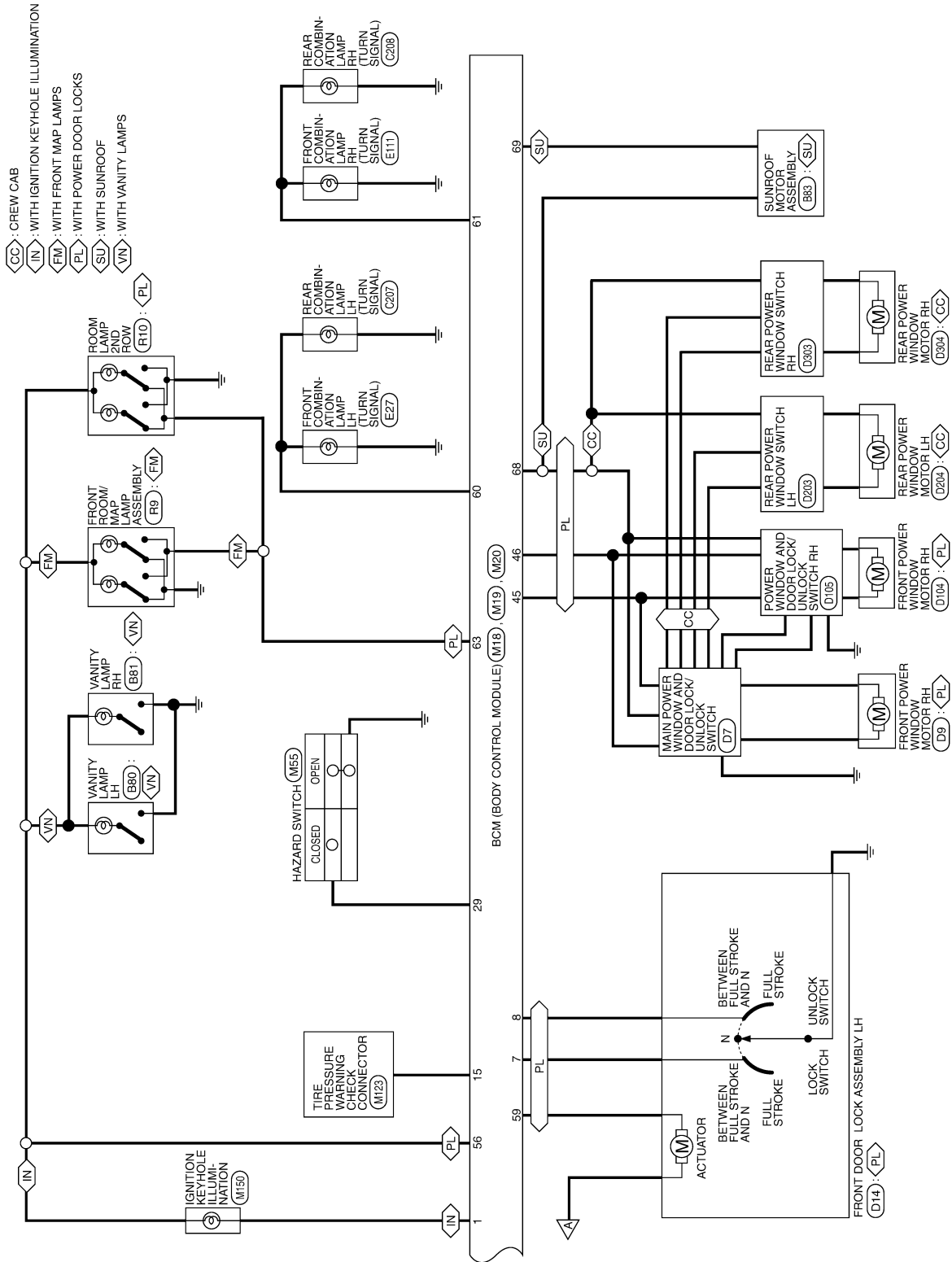

ABMWA0117GI

# BCM (BODY CONTROL MODULE)

< ECU DIAGNOSIS >

## BCM (BODY CONTROL MODULE) CONNECTORS

Connector No.	M18
Connector Name	BCM (BODY CONTROL MODULE)
Connector Color	WHITE



1	2	3	4	5	6	7	8	9	10	11	12	13	14	15	16	17	18	19	20
21	22	23	24	25	26	27	28	29	30	31	32	33	34	35	36	37	38	39	40

Terminal No.	Color of Wire	Signal Name
1	BR	KEY RING OUTPUT
2	P	INPUT 5
3	SB	INPUT 4
4	V	INPUT 3
5	L	INPUT 2
6	R	INPUT 1
7	GR	KEY CYLINDER UNLOCK SW
8	SB	KEY CYLINDER LOCK SW
9	Y	RR DEFOGGER SW
10	-	-
11	G/B	ACC_SW
12	LG	DOOR SW (AS)
13	L	DOOR SW (RR)
14	-	-
15	W	TPMS MODE TRIGGER SW
16	-	-
17	-	-
18	BR	KEYLESS & AUTO LIGHT SENSOR GND
19	V	KEYLESS TUNER POWER SUPPLY OUTPUT

Terminal No.	Color of Wire	Signal Name
20	G	KEYLESS TUNER SIGNAL
21	GR	IMMOBILIZER ANTENNA SIGNAL (CLOCK)
22	-	-
23	G	SECURITY INDICATOR OUTPUT
24	-	-
25	BR	IMMOBILIZER ANTENNA SIGNAL (RX, TX)
26	-	-
27	W	AIRCON SW
28	R	BLOWER FAN SW
29	G	HAZARD SW
30	-	-
31	GR	CARGO LAMP SW
32	O	OUTPUT 5
33	GR	OUTPUT 4
34	G	OUTPUT 3
35	BR	OUTPUT 2
36	LG	OUTPUT 1
37	B	KEY SW
38	W/R	IGN SW
39	L	CAN-H
40	P	CAN-L

Connector No.	M19
Connector Name	BCM (BODY CONTROL MODULE)
Connector Color	WHITE



41	42	43	44	45	46	47	48	49
50	51	52	53	54	55			

Terminal No.	Color of Wire	Signal Name
41	-	-
42	-	-
43	-	-
44	-	-
45	V	CDL LOCK SW
46	LG	CDL UNLOCK SW
47	GR	DOOR SW (DR)
48	P	DOOR SW (RL)
49	-	-
50	P	CARGO LAMP OUTPUT
51	G	TRAILER FLASHER OUTPUT (RIGHT)
52	V	TRAILER FLASHER OUTPUT (LEFT)
53	-	-
54	-	-
55	-	-

ABM1A0315GB

A  
B  
C  
D  
E  
F  
G  
H  
I  
J  
K  
L  
M  
N  
O  
P

# BCM (BODY CONTROL MODULE)

< ECU DIAGNOSIS >

Connector No.	M28
Connector Name	COMBINATION SWITCH
Connector Color	WHITE

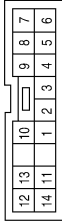

Terminal No.	Color of Wire	Signal Name
1	LG	INPUT 1
2	BR	INPUT 2
3	G	INPUT 3
4	GR	INPUT 4
5	O	INPUT 5
6	R	OUTPUT 1
7	L	OUTPUT 2
8	P	OUTPUT 5
9	SB	OUTPUT 4
10	V	OUTPUT 3
11	O	WASH FR (-) RR (+)
12	B	GND
13	L	WASH FR (-) RR (-)
14	W	IGN

Connector No.	M20
Connector Name	BCM (BODY CONTROL MODULE)
Connector Color	BLACK



Terminal No.	Color of Wire	Signal Name
56	V	BATTERY SAVER OUTPUT
57	R/Y	BAT (FUSE)
58	W	AUTO LIGHT SENSOR INPUT 2
59	GR	DOOR UNLOCK OUTPUT (DR)
60	LG	FLASHER OUTPUT (LEFT)
61	G	FLASHER OUTPUT (RIGHT)
62	-	-
63	BR	ROOM LAMP OUTPUT
64	-	-
65	V	DOOR LOCK OUTPUT (ALL)
66	L	DOOR UNLOCK OUTPUT (OTHER)
67	B	GND (POWER)
68	O	POWER WINDOW POWER SUPPLY OUTPUT (LINKED TO RAP)
69	P	POWER WINDOW POWER SUPPLY OUTPUT (BAT)
70	W	BAT (F/L)

ABMIA0316GB

INFOID:000000004449418

## Fail Safe

### Fail-safe index

BCM performs fail-safe control when any DTC listed below is detected.

# BCM (BODY CONTROL MODULE)

## < ECU DIAGNOSIS >

Display contents of CONSULT	Fail-safe	Cancellation
U1000: CAN COMM CIRCUIT	Inhibit engine cranking	When the BCM re-establishes communication with the other modules.
U1010: CONTROL UNIT (CAN)	Inhibit engine cranking	When the BCM re-start communicating with the other modules.

## DTC Inspection Priority Chart

INFOID:000000004449419

If some DTCs are displayed at the same time, perform inspections one by one based on the following priority chart.

Priority	DTC
1	<ul style="list-style-type: none"> <li>• U1000: CAN COMM CIRCUIT</li> <li>• U1010: CONTROL UNIT (CAN)</li> </ul>
2	<ul style="list-style-type: none"> <li>• B2190: NATS ANTENNA AMP</li> <li>• B2191: DIFFERENCE OF KEY</li> <li>• B2192: ID DISCORD BCM-ECM</li> <li>• B2193: CHAIN OF BCM-ECM</li> </ul>
3	<ul style="list-style-type: none"> <li>• C1729: VHCL SPEED SIG ERR</li> <li>• C1735: IGNITION SIGNAL</li> </ul>
4	<ul style="list-style-type: none"> <li>• C1704: LOW PRESSURE FL</li> <li>• C1705: LOW PRESSURE FR</li> <li>• C1706: LOW PRESSURE RR</li> <li>• C1707: LOW PRESSURE RL</li> <li>• C1708: [NO DATA] FL</li> <li>• C1709: [NO DATA] FR</li> <li>• C1710: [NO DATA] RR</li> <li>• C1711: [NO DATA] RL</li> <li>• C1712: [CHECKSUM ERR] FL</li> <li>• C1713: [CHECKSUM ERR] FR</li> <li>• C1714: [CHECKSUM ERR] RR</li> <li>• C1715: [CHECKSUM ERR] RL</li> <li>• C1716: [PRESSDATA ERR] FL</li> <li>• C1717: [PRESSDATA ERR] FR</li> <li>• C1718: [PRESSDATA ERR] RR</li> <li>• C1719: [PRESSDATA ERR] RL</li> <li>• C1720: [CODE ERR] FL</li> <li>• C1721: [CODE ERR] FR</li> <li>• C1722: [CODE ERR] RR</li> <li>• C1723: [CODE ERR] RL</li> <li>• C1724: [BATT VOLT LOW] FL</li> <li>• C1725: [BATT VOLT LOW] FR</li> <li>• C1726: [BATT VOLT LOW] RR</li> <li>• C1727: [BATT VOLT LOW] RL</li> </ul>

## DTC Index

INFOID:000000004449420

### NOTE:

- Details of time display
- CRNT: Displays when there is a malfunction now or after returning to the normal condition until turning ignition switch OFF → ON again.
- 1 - 39: Displayed if any previous malfunction is present when current condition is normal. It increases like 1 → 2 → 3...38 → 39 after returning to the normal condition whenever ignition switch OFF → ON. The counter remains at 39 even if the number of cycles exceeds it. It is counted from 1 again when turning ignition switch OFF → ON after returning to the normal condition if the malfunction is detected again.

## BCM (BODY CONTROL MODULE)

### < ECU DIAGNOSIS >

CONSULT display	Fail-safe	Tire pressure monitor warning lamp ON	Reference page
No DTC is detected. further testing may be required.	—	—	—
U1000: CAN COMM CIRCUIT	—	—	<a href="#">BCS-30</a>
U1010: CONTROL UNIT (CAN)	—	—	<a href="#">BCS-31</a>
B2190: NATS ANTENA AMP	—	—	<a href="#">SEC-18</a>
B2191: DIFFERENCE OF KEY	—	—	<a href="#">SEC-21</a>
B2192: ID DISCORD BCM-ECM	—	—	<a href="#">SEC-22</a>
B2193: CHAIN OF BCM-ECM	—	—	<a href="#">SEC-24</a>
C1708: [NO DATA] FL	—	—	<a href="#">WT-14</a>
C1709: [NO DATA] FR	—	—	<a href="#">WT-14</a>
C1710: [NO DATA] RR	—	—	<a href="#">WT-14</a>
C1711: [NO DATA] RL	—	—	<a href="#">WT-14</a>
C1712: [CHECKSUM ERR] FL	—	—	<a href="#">WT-16</a>
C1713: [CHECKSUM ERR] FR	—	—	<a href="#">WT-16</a>
C1714: [CHECKSUM ERR] RR	—	—	<a href="#">WT-16</a>
C1715: [CHECKSUM ERR] RL	—	—	<a href="#">WT-16</a>
C1716: [PRESSDATA ERR] FL	—	—	<a href="#">WT-18</a>
C1717: [PRESSDATA ERR] FR	—	—	<a href="#">WT-18</a>
C1718: [PRESSDATA ERR] RR	—	—	<a href="#">WT-18</a>
C1719: [PRESSDATA ERR] RL	—	—	<a href="#">WT-18</a>
C1720: [CODE ERR] FL	—	—	<a href="#">WT-16</a>
C1721: [CODE ERR] FR	—	—	<a href="#">WT-16</a>
C1722: [CODE ERR] RR	—	—	<a href="#">WT-16</a>
C1723: [CODE ERR] RL	—	—	<a href="#">WT-16</a>
C1724: [BATT VOLT LOW] FL	—	—	<a href="#">WT-16</a>
C1725: [BATT VOLT LOW] FR	—	—	<a href="#">WT-16</a>
C1726: [BATT VOLT LOW] RR	—	—	<a href="#">WT-16</a>
C1727: [BATT VOLT LOW] RL	—	—	<a href="#">WT-16</a>
C1729: VHCL SPEED SIG ERR	—	—	<a href="#">WT-19</a>
C1735: IGNITION SIGNAL	—	—	—

# POWER WINDOW SYSTEM

< ECU DIAGNOSIS >

## POWER WINDOW SYSTEM

### Terminal Layout for Power Window Main Switch

INFOID:000000004056301

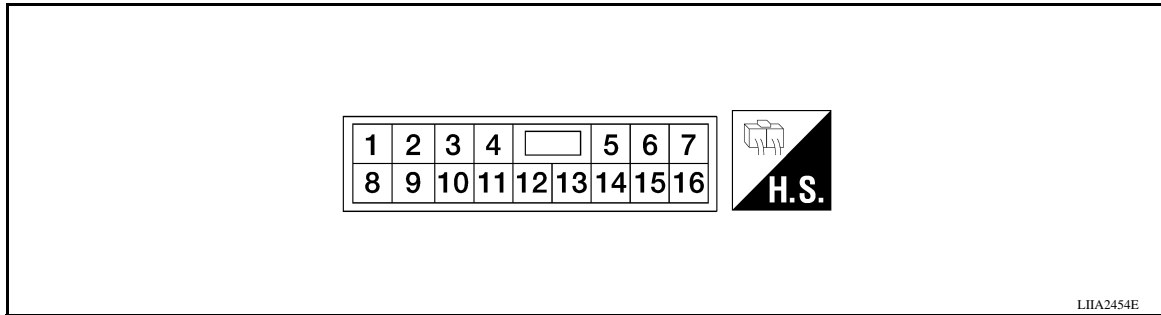

### Physical Values for Power Window Main Switch

INFOID:000000004056302

Terminal	Wire Color	Item	Condition	Voltage (V) (Approx.)
2	G/Y	Front power window motor RH DOWN signal	When power window motor is operated DOWN	Battery voltage
3	L/W	Front power window motor RH UP signal	When power window motor is operated UP	Battery voltage
5	W/R	RAP signal	When ignition switch ON	Battery voltage
			Within 45 seconds after ignition switch is turned to OFF	Battery voltage
			More than 45 seconds after ignition switch is turned to OFF	0
			When front door LH or RH open or power window timer operates	0
6	G/R	Front power window motor LH UP signal	When power window motor is operated UP	Battery voltage
7	G/W	Front power window motor LH DOWN signal	When power window motor is operated DOWN	Battery voltage
8*	G/B	Rear power window RH UP signal	When rear RH switch in main power window and door lock/unlock switch is operated UP	Battery voltage
9*	R	Rear power window RH DOWN signal	When rear RH switch in main power window and door lock/unlock switch is operated DOWN	Battery voltage
14	B	Ground	—	0
15*	R/B	Rear power window LH UP signal	When rear LH switch in main power window and door lock/unlock switch is operated UP	Battery voltage
16*	R/Y	Rear power window LH DOWN signal	When rear LH switch in main power window and door lock/unlock switch is operated DOWN	Battery voltage

\*: Crew cab

# POWER WINDOW SYSTEM

< ECU DIAGNOSIS >

## Wiring Diagram

INFOID:000000004056303

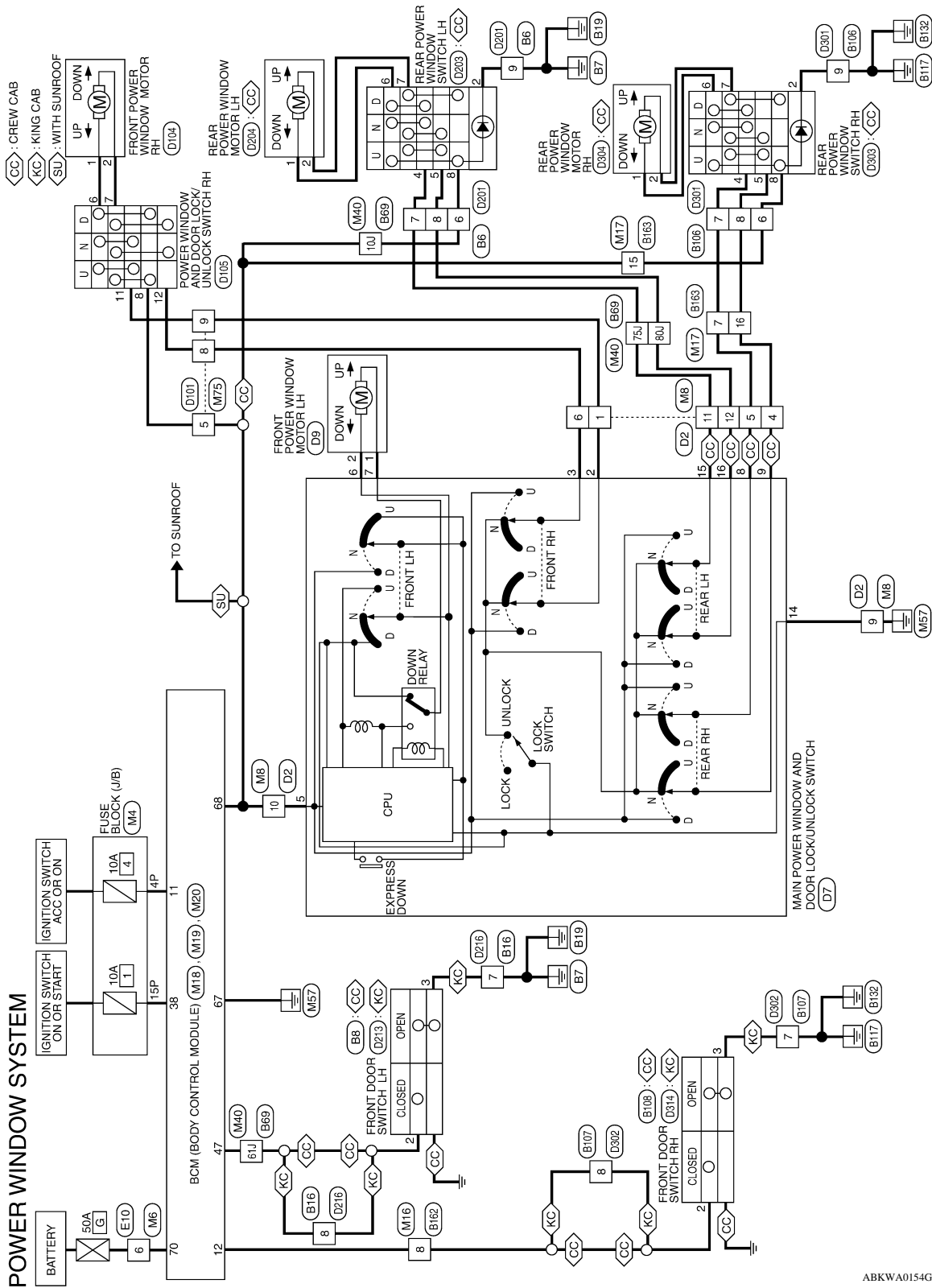

ABKWA0154GE



## POWER WINDOW SYSTEM CONNECTORS

Connector No.	M4
Connector Name	FUSE BLOCK (J/B)
Connector Color	WHITE



Terminal No.	Color of Wire	Signal Name
4P	G/B	-
15P	W/R	-

Connector No.	M6
Connector Name	WIRE TO WIRE
Connector Color	WHITE



Terminal No.	Color of Wire	Signal Name
6	W	-

Connector No.	M8
Connector Name	WIRE TO WIRE
Connector Color	BROWN

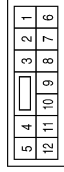

Terminal No.	Color of Wire	Signal Name
1	SB	-
4	P	-
5	Y	-
6	P	-
9	B	-
10	O	-
11	R	-
12	LG	-

Connector No.	M16
Connector Name	WIRE TO WIRE
Connector Color	WHITE

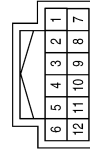

Terminal No.	Color of Wire	Signal Name
8	LG	-

Connector No.	M17
Connector Name	WIRE TO WIRE
Connector Color	WHITE

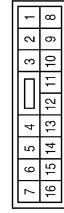

Terminal No.	Color of Wire	Signal Name
7	Y	-
15	W	-
16	P	-

Connector No.	M18
Connector Name	BCM (BODY CONTROL MODULE)
Connector Color	WHITE

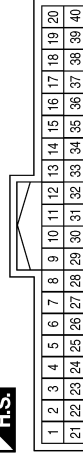

Terminal No.	Color of Wire	Signal Name
11	G/B	ACC SW
12	LG	DOOR SW (AS)
38	W/R	IGN SW

ABKIA0496GB

# POWER WINDOW SYSTEM

< ECU DIAGNOSIS >

Connector No.	M19
Connector Name	BCM (BODY CONTROL MODULE)
Connector Color	WHITE

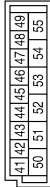

Terminal No.	Color of Wire	Signal Name
47	GR	DOOR SW (DR)

Connector No.	M20
Connector Name	BCM (BODY CONTROL MODULE)
Connector Color	BLACK

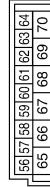

Terminal No.	Color of Wire	Signal Name
67	B	GND (POWER)
68	O	POWER WINDOW POWER SUPPLY OUTPUT (LINKED TO RAP)
70	W	BAT (F/L)

Connector No.	M40
Connector Name	WIRE TO WIRE
Connector Color	WHITE

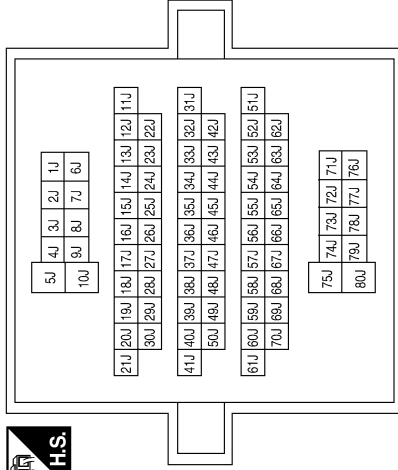

Terminal No.	Color of Wire	Signal Name
10J	W	-
61J	GR	-
75J	R	-
80J	LG	-

Connector No.	M75
Connector Name	WIRE TO WIRE
Connector Color	WHITE

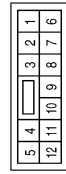

Terminal No.	Color of Wire	Signal Name
5	W	-
8	P	-
9	SB	-

Connector No.	E10
Connector Name	WIRE TO WIRE
Connector Color	WHITE



Terminal No.	Color of Wire	Signal Name
6	W	-

Connector No.	B6
Connector Name	WIRE TO WIRE (CREW CAB)
Connector Color	WHITE

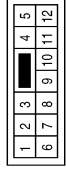

Terminal No.	Color of Wire	Signal Name
6	W	-
7	R	-
8	LG	-
9	B	-

ABKIA0497GB

# POWER WINDOW SYSTEM

< ECU DIAGNOSIS >

Connector No.	B8
Connector Name	FRONT DOOR SWITCH LH (CREW CAB)
Connector Color	WHITE

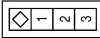

Terminal No.	Color of Wire	Signal Name
2	GR	-

Connector No.	B16
Connector Name	WIRE TO WIRE
Connector Color	WHITE

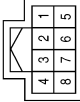

Terminal No.	Color of Wire	Signal Name
7	B	-
8	GR	-

Connector No.	B69
Connector Name	WIRE TO WIRE
Connector Color	WHITE

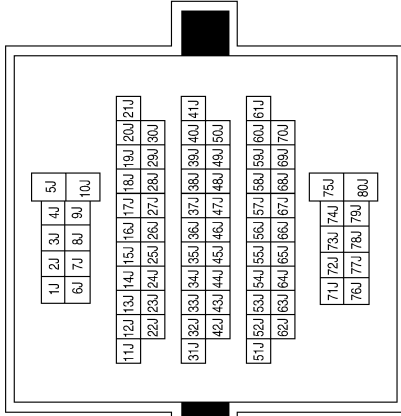

Terminal No.	Color of Wire	Signal Name
10J	W	-
61J	GR	-
75J	R	-
80J	LG	-

Connector No.	B106
Connector Name	WIRE TO WIRE (CREW CAB)
Connector Color	WHITE

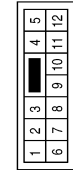

Terminal No.	Color of Wire	Signal Name
6	W	-
7	Y	-
8	P	-
9	B	-

Connector No.	B107
Connector Name	WIRE TO WIRE
Connector Color	WHITE

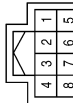

Terminal No.	Color of Wire	Signal Name
7	B	-
8	LG	-

Connector No.	B108
Connector Name	FRONT DOOR SWITCH RH (CREW CAB)
Connector Color	WHITE



Terminal No.	Color of Wire	Signal Name
2	LG	-

ABKIA0498GB

A B C D E F G H I J L M N O P

PWC

# POWER WINDOW SYSTEM

< ECU DIAGNOSIS >

Connector No.	B162
Connector Name	WIRE TO WIRE
Connector Color	WHITE

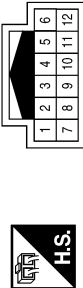

Terminal No.	Color of Wire	Signal Name
8	LG	-

Connector No.	B163
Connector Name	WIRE TO WIRE
Connector Color	WHITE

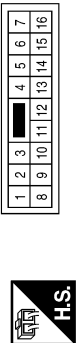

Terminal No.	Color of Wire	Signal Name
7	Y	-
15	W	-
16	P	-

Connector No.	D2
Connector Name	WIRE TO WIRE
Connector Color	BROWN

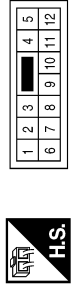

Terminal No.	Color of Wire	Signal Name
1	G/Y	-
4	R	-
5	G/B	-
6	L/W	-
9	B	-
10	W/R	-
11	R/B	-
12	R/Y	-

Connector No.	D7
Connector Name	MAIN POWER WINDOW AND DOOR LOCK/UNLOCK SWITCH
Connector Color	WHITE

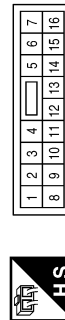

Terminal No.	Color of Wire	Signal Name
2	G/Y	-
3	L/W	-
5	W/R	-
6	G/R	-
7	G/W	-
8	G/B	-
9	R	-

Terminal No.	Color of Wire	Signal Name
14	B	-
15	R/B	-
16	R/Y	-

Connector No.	D9
Connector Name	FRONT POWER WINDOW MOTOR LH
Connector Color	BROWN



Terminal No.	Color of Wire	Signal Name
1	G/W	-
2	G/R	-

ABKIA0499GB

# POWER WINDOW SYSTEM

< ECU DIAGNOSIS >

Connector No.	D105
Connector Name	POWER WINDOW AND DOOR LOCK/UNLOCK SWITCH RH
Connector Color	WHITE

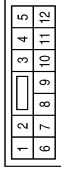

Terminal No.	Color of Wire	Signal Name
6	G	-
7	L	-
8	W/R	-
11	G/Y	-
12	L/W	-

Connector No.	D104
Connector Name	FRONT POWER WINDOW MOTOR RH
Connector Color	BROWN

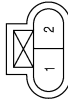

Terminal No.	Color of Wire	Signal Name
1	G	-
2	L	-

Connector No.	D101
Connector Name	WIRE TO WIRE
Connector Color	WHITE

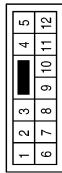

Terminal No.	Color of Wire	Signal Name
5	W/R	-
8	L/W	-
9	G/Y	-

Connector No.	D204
Connector Name	REAR POWER WINDOW MOTOR LH
Connector Color	BLACK



Terminal No.	Color of Wire	Signal Name
1	Y	-
2	L	-

Connector No.	D203
Connector Name	REAR POWER WINDOW SWITCH LH
Connector Color	WHITE



Terminal No.	Color of Wire	Signal Name
2	B	-
4	LG	-
5	R	-
6	Y	-
7	L	-
8	W	-

Connector No.	D201
Connector Name	WIRE TO WIRE (CREW CAB)
Connector Color	WHITE

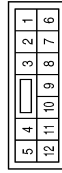

Terminal No.	Color of Wire	Signal Name
6	W	-
7	LG	-
8	R	-
9	B	-

ABKIA0500GB

A B C D E F G H I J L M N O P

# POWER WINDOW SYSTEM

< ECU DIAGNOSIS >

Connector No.	D213
Connector Name	FRONT DOOR SWITCH LH (KING CAB)
Connector Color	WHITE

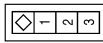

Terminal No.	Color of Wire	Signal Name
2	LG	-
3	B	-

Connector No.	D216
Connector Name	WIRE TO WIRE
Connector Color	WHITE

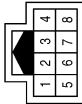

Terminal No.	Color of Wire	Signal Name
7	B	-
8	LG	-

Connector No.	D301
Connector Name	WIRE TO WIRE (CREW CAB)
Connector Color	WHITE

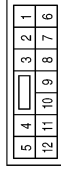

Terminal No.	Color of Wire	Signal Name
6	W	-
7	LG	-
8	R	-
9	B	-

Connector No.	D302
Connector Name	WIRE TO WIRE
Connector Color	WHITE

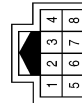

Terminal No.	Color of Wire	Signal Name
7	B	-
8	LG	-

Connector No.	D303
Connector Name	REAR POWER WINDOW SWITCH RH
Connector Color	WHITE



Terminal No.	Color of Wire	Signal Name
2	B	-
4	LG	-
5	R	-
6	Y	-
7	L	-
8	W	-

Connector No.	D304
Connector Name	REAR POWER WINDOW MOTOR RH
Connector Color	BLACK



Terminal No.	Color of Wire	Signal Name
1	Y	-
2	L	-

ABKIA0501GB

# POWER WINDOW SYSTEM

< ECU DIAGNOSIS >

A  
B  
C  
D  
E  
F  
G  
H  
I  
J  
L  
M  
N  
O  
P

PWC

Connector No.	D314
Connector Name	FRONT DOOR SWITCH RH (KING CAB)
Connector Color	WHITE

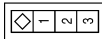

Terminal No.	Color of Wire	Signal Name
2	LG	-
3	B	-

ABKIA0502GB

# NONE OF THE POWER WINDOWS CAN BE OPERATED USING ANY SWITCH

< SYMPTOM DIAGNOSIS >

## SYMPTOM DIAGNOSIS

NONE OF THE POWER WINDOWS CAN BE OPERATED USING ANY SWITCH

### Diagnosis Procedure

INFOID:000000004056304

#### 1. CHECK BCM POWER SUPPLY AND GROUND CIRCUIT

Check BCM power supply and ground circuit.

Refer to [BCS-32, "Diagnosis Procedure"](#).

Is the inspection result normal?

YES >> GO TO 2

NO >> Repair or replace the malfunctioning parts.

#### 2. CHECK MAIN POWER WINDOW AND DOOR LOCK/UNLOCK SWITCH

Check main power window switch.

Refer to [PWC-12, "POWER WINDOW MAIN SWITCH \(CREW CAB\) : Component Inspection"](#) or [PWC-15, "POWER WINDOW MAIN SWITCH \(KING CAB\) : Component Inspection"](#).

Is the inspection result normal?

YES >> GO TO 3

NO >> Replace main power window and door lock/unlock switch. Refer to [PWC-65, "Removal and Installation"](#).

#### 3. CHECK MAIN POWER WINDOW AND DOOR LOCK/UNLOCK SWITCH POWER SUPPLY AND GROUND CIRCUIT

Check power window switch main power supply and ground circuit.

Refer to [PWC-9, "POWER WINDOW MAIN SWITCH \(CREW CAB\) : Component Function Check"](#) or [PWC-13, "POWER WINDOW MAIN SWITCH \(KING CAB\) : Component Function Check"](#).

Is the inspection result normal?

YES >> Check intermittent incident. Refer to [GI-49, "Intermittent Incident"](#).

NO >> Repair or replace the malfunctioning parts.



# DRIVER SIDE POWER WINDOW ALONE DOES NOT OPERATE

< SYMPTOM DIAGNOSIS >

---

## DRIVER SIDE POWER WINDOW ALONE DOES NOT OPERATE

### Diagnosis Procedure

INFOID:000000004056305

#### 1. CHECK FRONT POWER WINDOW MOTOR LH

---

Check front power window motor LH.

Refer to [PWC-20, "DRIVER SIDE : Component Function Check"](#).

Is the inspection result normal?

YES >> Inspection End.

NO >> Check intermittent incident. Refer to [GI-49, "Intermittent Incident"](#).

A  
B  
C  
D  
E  
F  
G  
H  
I  
J  
L  
M  
N  
O  
P

PWC

# FRONT PASSENGER SIDE POWER WINDOW ALONE DOES NOT OPERATE

< SYMPTOM DIAGNOSIS >

## FRONT PASSENGER SIDE POWER WINDOW ALONE DOES NOT OPERATE

### Diagnosis Procedure

INFOID:000000004056306

#### 1. CHECK POWER WINDOW AND DOOR LOCK/UNLOCK SWITCH RH

Check power window and door lock/unlock switch RH.

Refer to [PWC-15, "FRONT POWER WINDOW SWITCH : Component Function Check"](#).

Is the inspection result normal?

YES >> GO TO 2

NO >> Repair or replace the malfunctioning parts.

#### 2. CHECK MAIN POWER WINDOW AND DOOR LOCK/UNLOCK SWITCH

Check main power window and door lock/unlock switch.

Refer to [PWC-12, "POWER WINDOW MAIN SWITCH \(CREW CAB\) : Component Inspection"](#) or [PWC-15, "POWER WINDOW MAIN SWITCH \(KING CAB\) : Component Inspection"](#).

Is the inspection result normal?

YES >> GO TO 3

NO >> Replace main power window and door lock/unlock switch. Refer to [PWC-65, "Removal and Installation"](#).

#### 3. CHECK FRONT POWER WINDOW MOTOR RH CIRCUIT

Check front power window motor RH circuit.

Refer to [PWC-21, "PASSENGER SIDE : Component Function Check"](#).

Is the inspection result normal?

YES >> Inspection End.

NO >> Check intermittent incident. Refer to [GI-49, "Intermittent Incident"](#).

# REAR LH SIDE POWER WINDOW ALONE DOES NOT OPERATE

< SYMPTOM DIAGNOSIS >

## REAR LH SIDE POWER WINDOW ALONE DOES NOT OPERATE

### Diagnosis Procedure

INFOID:000000004056307

#### 1. CHECK REAR POWER WINDOW SWITCH LH

Check rear power window switch LH.

Refer to [PWC-17, "REAR POWER WINDOW SWITCH : Component Function Check"](#).

Is the inspection result normal?

YES >> GO TO 2

NO >> Repair or replace the malfunctioning parts.

#### 2. CHECK MAIN POWER WINDOW AND DOOR LOCK/UNLOCK SWITCH

Check main power window and door lock/unlock switch.

Refer to [PWC-12, "POWER WINDOW MAIN SWITCH \(CREW CAB\) : Component Inspection"](#).

Is the inspection result normal?

YES >> GO TO 3

NO >> Replace main power window and door lock/unlock switch. Refer to [PWC-65, "Removal and Installation"](#).

#### 3. CHECK REAR POWER WINDOW MOTOR LH

Check rear power window motor LH.

Refer to [PWC-23, "REAR LH : Component Function Check"](#).

Is the inspection result normal?

YES >> Inspection End.

NO >> Check intermittent incident. Refer to [GI-49, "Intermittent Incident"](#).

A  
B  
C  
D  
E  
F  
G  
H  
I  
J  
L  
M  
N  
O  
P

PWC

# REAR RH SIDE POWER WINDOW ALONE DOES NOT OPERATE

< SYMPTOM DIAGNOSIS >

---

## REAR RH SIDE POWER WINDOW ALONE DOES NOT OPERATE

### Diagnosis Procedure

INFOID:000000004056308

#### 1. CHECK REAR POWER WINDOW SWITCH RH

---

Check rear power window switch RH.

Refer to [PWC-17, "REAR POWER WINDOW SWITCH : Component Function Check"](#).

Is the inspection result normal?

YES >> GO TO 2

NO >> Repair or replace the malfunctioning parts.

#### 2. CHECK MAIN POWER WINDOW AND DOOR LOCK/UNLOCK SWITCH

---

Check main power window and door lock/unlock switch.

Refer to [PWC-12, "POWER WINDOW MAIN SWITCH \(CREW CAB\) : Component Inspection"](#).

Is the inspection result normal?

YES >> GO TO 3

NO >> Replace main power window and door lock/unlock switch. Refer to [PWC-65, "Removal and Installation"](#).

#### 3. CHECK REAR POWER WINDOW MOTOR RH

---

Check rear power window motor RH.

Refer to [PWC-24, "REAR RH : Component Function Check"](#).

Is the inspection result normal?

YES >> Inspection End.

NO >> Check intermittent incident. Refer to [GI-49, "Intermittent Incident"](#).

# AUTO OPERATION DOES NOT OPERATE BUT MANUAL OPERATE NORMALLY (DRIVER SIDE)

< SYMPTOM DIAGNOSIS >

## AUTO OPERATION DOES NOT OPERATE BUT MANUAL OPERATE NORMALLY (DRIVER SIDE)

### Diagnosis Procedure

INFOID:000000004056309

#### 1. REPLACE MAIN POWER WINDOW AND DOOR LOCK/UNLOCK SWITCH

Replace main power window and door lock/unlock switch and check operation. Refer to [PWC-65, "Removal and Installation"](#).

Is the inspection result normal?

YES >> Inspection End.

NO >> Check intermittent incident. Refer to [GI-49, "Intermittent Incident"](#).

A  
B  
C  
D  
E  
F  
G  
H  
I  
J  
L  
M  
N  
O  
P

PWC

# POWER WINDOW RETAINED POWER OPERATION DOES NOT OPERATE PROPERLY

< SYMPTOM DIAGNOSIS >

---

## POWER WINDOW RETAINED POWER OPERATION DOES NOT OPERATE PROPERLY

### Diagnosis Procedure

INFOID:000000004056310

#### 1. CHECK FRONT DOOR SWITCH

---

Check front door switch.

Refer to [DLK-29, "CREW CAB : Component Function Check"](#) or [DLK-27, "KING CAB : Component Function Check"](#).

Is the inspection result normal?

YES >> Inspection End.

NO >> Check intermittent incident. Refer to [GI-49, "Intermittent Incident"](#).

# POWER WINDOW LOCK SWITCH DOES NOT FUNCTION

< SYMPTOM DIAGNOSIS >

---

## POWER WINDOW LOCK SWITCH DOES NOT FUNCTION

### Diagnosis Procedure

INFOID:000000004056311

#### 1. REPLACE MAIN POWER WINDOW AND DOOR LOCK/UNLOCK SWITCH

---

Replace main power window and door lock/unlock switch and check operation.  
Refer to [PWC-65, "Removal and Installation"](#).

Is the inspection result normal?

YES >> Inspection End.

NO >> Check intermittent incident. Refer to [GI-49, "Intermittent Incident"](#).

A  
B  
C  
D  
E  
F  
G  
H  
I  
J  
L  
M  
N  
O  
P

PWC

# PRECAUTIONS

< PRECAUTION >

---

## PRECAUTION

### PRECAUTIONS

#### Precaution for Supplemental Restraint System (SRS) "AIR BAG" and "SEAT BELT PRE-TENSIONER"

INFOID:000000004056312

The Supplemental Restraint System such as "AIR BAG" and "SEAT BELT PRE-TENSIONER", used along with a front seat belt, helps to reduce the risk or severity of injury to the driver and front passenger for certain types of collision. This system includes seat belt switch inputs and dual stage front air bag modules. The SRS system uses the seat belt switches to determine the front air bag deployment, and may only deploy one front air bag, depending on the severity of a collision and whether the front occupants are belted or unbelted. Information necessary to service the system safely is included in the SR and SB section of this Service Manual.

**WARNING:**

- To avoid rendering the SRS inoperative, which could increase the risk of personal injury or death in the event of a collision which would result in air bag inflation, all maintenance must be performed by an authorized NISSAN/INFINITI dealer.
- Improper maintenance, including incorrect removal and installation of the SRS, can lead to personal injury caused by unintentional activation of the system. For removal of Spiral Cable and Air Bag Module, see the SR section.
- Do not use electrical test equipment on any circuit related to the SRS unless instructed to in this Service Manual. SRS wiring harnesses can be identified by yellow and/or orange harnesses or harness connectors.



# POWER WINDOW MAIN SWITCH

< ON-VEHICLE REPAIR >

## ON-VEHICLE REPAIR

### POWER WINDOW MAIN SWITCH

#### Removal and Installation

INFOID:000000004056313

#### REMOVAL

1. Remove the power window main switch finisher (2) from the front door finisher LH. Refer to [INT-13, "Removal and Installation"](#).
2. Remove the three screws (A) from the power window main switch (1), then separate from the finisher (2).

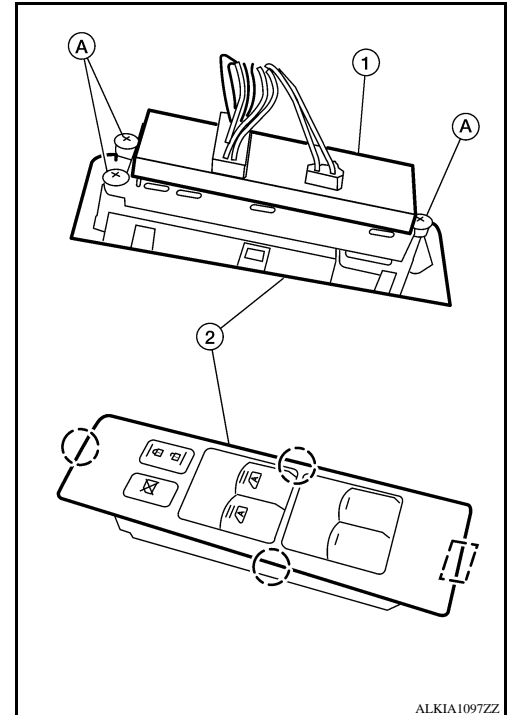

#### INSTALLATION

Installation is in the reverse order of removal.

A

B

C

D

E

F

G

H

I

J

PWC

L

M

N

O

P

# FRONT POWER WINDOW SWITCH

< ON-VEHICLE REPAIR >

## FRONT POWER WINDOW SWITCH

### Removal and Installation

INFOID:000000004056314

#### REMOVAL

1. Remove the front power window switch finisher (2) from the front door finisher RH. Refer to [INT-13, "Removal and Installation"](#).
2. Release the four tabs (A), two on each side, then separate the front power window switch (1) from the finisher (2).

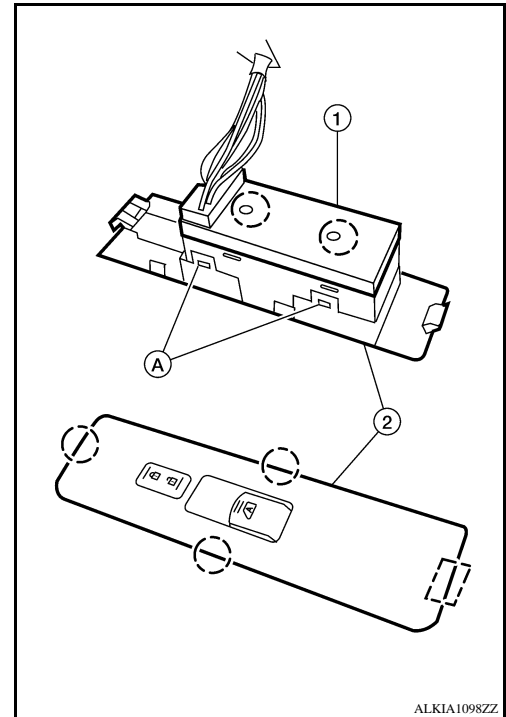

#### INSTALLATION

Installation is in the reverse order of removal.

# REAR POWER WINDOW SWITCH

< ON-VEHICLE REPAIR >

## REAR POWER WINDOW SWITCH

### Removal and Installation - Rear Door Switch (if equipped)

INFOID:000000004056315

#### REMOVAL

1. Remove the rear power window switch finisher (2) from the rear door finisher. Refer to [INT-13, "Removal and Installation"](#).
2. Release the two tabs (A), one on either side, then separate the rear power window switch (1) from the finisher (2).

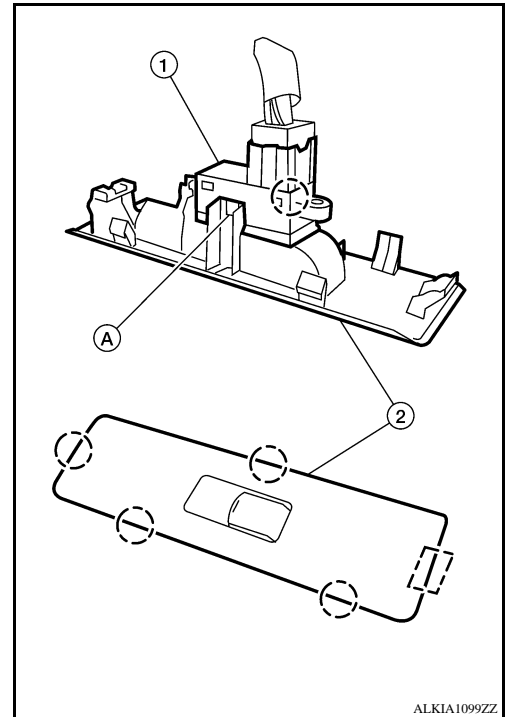

#### INSTALLATION

Installation is in the reverse order of removal.

A  
B  
C  
D  
E  
F  
G  
H  
I  
J  
L  
M  
N  
O  
P

PWC