

A
SECTION **EX** EX
EXHAUST SYSTEM C

D
E
CONTENTS

PREPARATION	2	INSTALLATION (CR, HR ENGINE)	6	F
Special Service Tool	2	INSTALLATION (K9K ENGINE)	7	
EXHAUST SYSTEM	3	Inspection After Installation	7	
Checking Exhaust System	3	SERVICE DATA AND SPECIFICATIONS (SDS)	8	G
Removal and Installation	3	Tightening Torque	8	
CR ENGINE	3	CR ENGINE	8	
HR ENGINE	4	HR ENGINE	8	H
K9K ENGINE	5	K9K ENGINE	8	
REMOVAL	5			I

PREPARATION

PREPARATION

PFP:00002

Special Service Tool

BBS003Z4

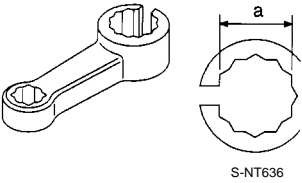
Tool number Tool name	Description
<p data-bbox="140 338 451 395">KV10117200 Heated oxygen sensor wrench</p>  <p data-bbox="836 540 895 561">S-NT636</p>	<p data-bbox="999 338 1394 395">Loosening or tightening heated oxygen sensors</p> <p data-bbox="999 397 1193 425">a: 22 mm (0.87 in)</p>

EXHAUST SYSTEM

EXHAUST SYSTEM

PPF:20100

Checking Exhaust System

BBS003Z5

Check exhaust pipes, muffler and mounting for improper attachment, leaks, cracks, damage or deterioration.

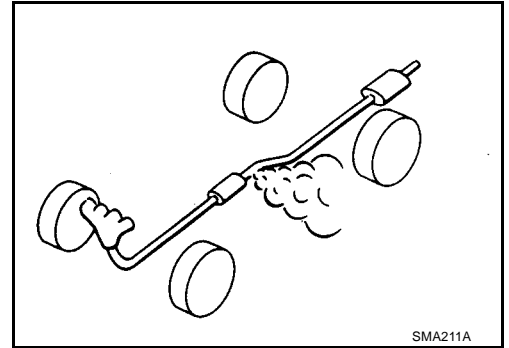

Removal and Installation

BBS003Z6

CAUTION:

- Be sure to use genuine exhaust system parts or equivalents which are specially designed for heat resistance, corrosion resistance and shape.
- Perform the operation with the exhaust system fully cooled down because the system is still hot just after the engine stops.
- Be careful not to cut your hand on the insulator edge.

CR ENGINE

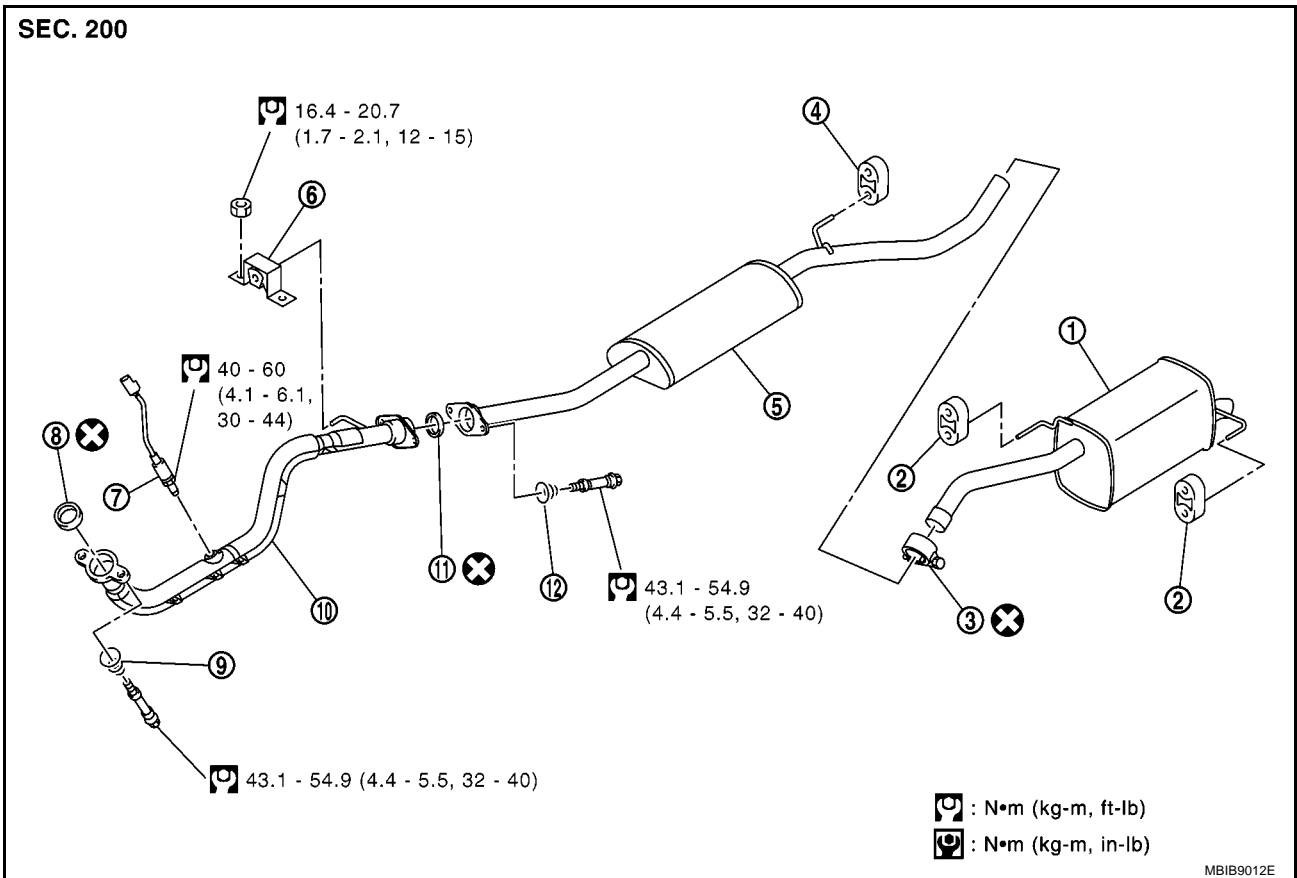

- | | | |
|---------------------------|--------------------|---------------------|
| 1. Main muffler | 2. Mounting rubber | 3. Clamp |
| 4. Mounting rubber | 5. Center muffler | 6. Mounting bracket |
| 7. Heated oxygen sensor 2 | 8. Seal bearing | 9. Spring |
| 10. Exhaust front tube | 11. Seal bearing | 12. Spring |

EXHAUST SYSTEM

HR ENGINE

SEC. 200

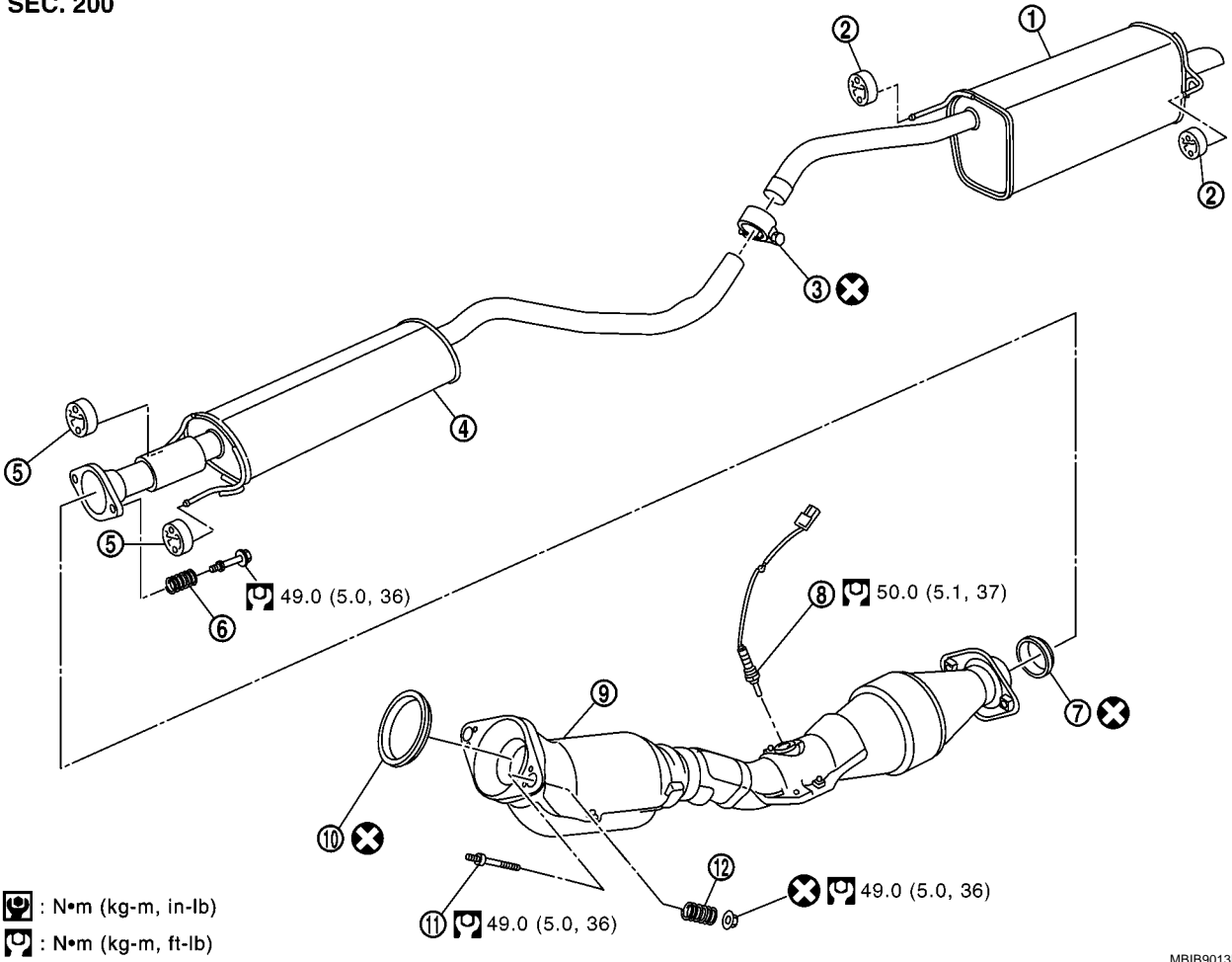

- | | | |
|-------------------|---------------------------|-----------------------|
| 1. Main muffler | 2. Mounting rubber | 3. Clamp |
| 4. Center muffler | 5. Mounting rubber | 6. Spring |
| 7. Seal bearing | 8. Heated oxygen sensor 2 | 9. Exhaust front tube |
| 10. Seal bearing | 11. Stud bolt | 12. Spring |

EXHAUST SYSTEM

K9K ENGINE

SEC. 200

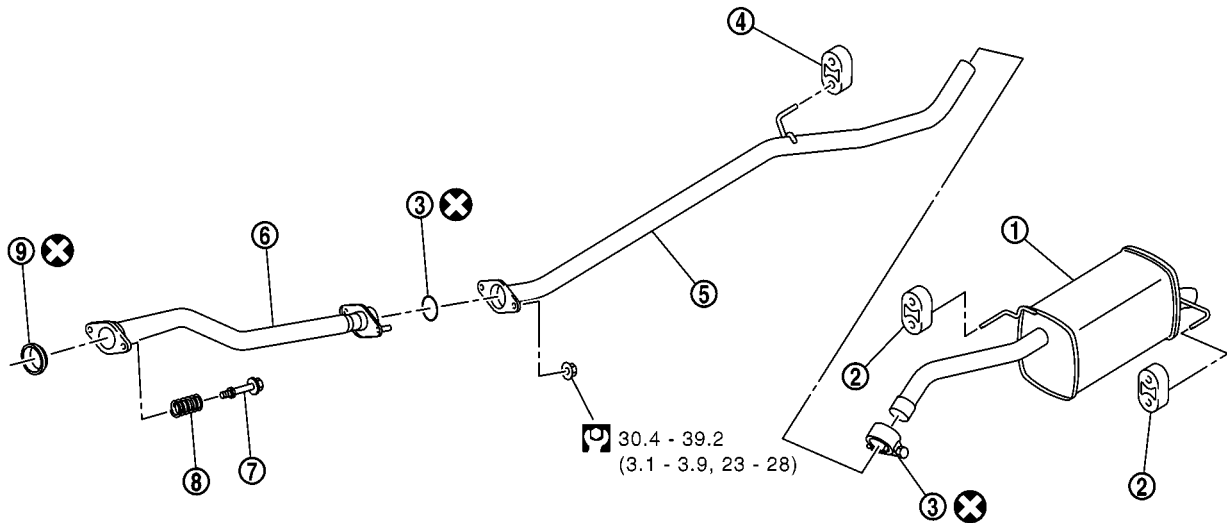

: N•m (kg-m, ft-lb)

MBIB9014E

- | | | |
|--------------------|------------------------|-----------------------|
| 1. Main muffler | 2. Mounting rubber | 3. Clamp |
| 4. Mounting rubber | 5. Exhaust center tube | 6. Exhaust front tube |
| 7. Bolt | 8. Spring | 9. Seal bearing |

REMOVAL

- Disconnect each joint and mounting.

Heated Oxygen Sensor 2 (CR, HR Engine)

- When removing heated oxygen sensor 2 on vehicle, perform following procedure.
1. Disconnect harness connector.
 2. Use a heated oxygen sensor wrench (special service tool) for removal of heated oxygen sensor 2.

CAUTION:

- Do not apply impact while handling.

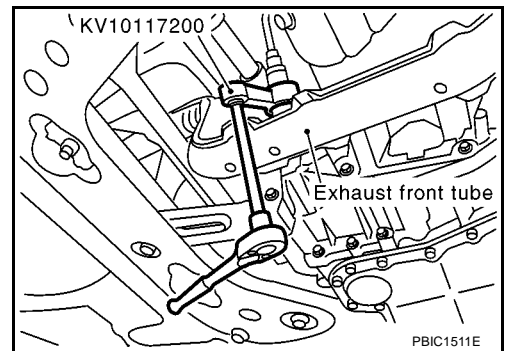

PBIC1511E

EXHAUST SYSTEM

Exhaust Front Tube (CR, HR Engine)

1. Disconnect center muffler connecting points.
2. Remove the ground cable on vehicle.
3. Remove mount bracket mounting nuts on suspension member.
4. Disconnect three way catalyst connecting points to remove exhaust front tube.

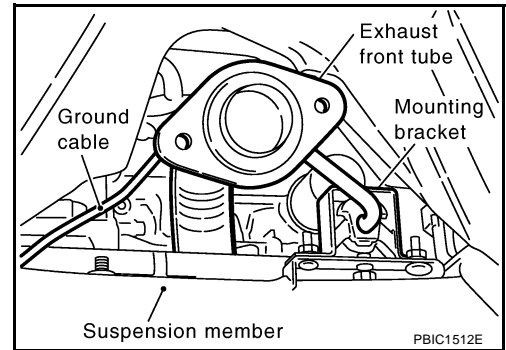

INSTALLATION (CR, HR ENGINE)

Install in the reverse order of removal paying attention to the following.

- Remove all deposits, such as old gasket, from the sealing surfaces of each connection. Connect firmly without any leaks.
- When installing exhaust pipe assembly, temporarily tighten nuts on the exhaust manifold side mounting bolts and vehicle side mounting nuts. After making sure there is no unusual tension on each part, tighten nuts and bolts to the specified torque.
- Be careful not to twist or apply excess tension in any direction when installing mounting rubbers.
- Because thickness is different between center muffler rear side mounting rubber and main muffler side mounting rubbers, install thick mount rubber at main muffler side.
- Install seal bearing unit in the following procedures.
- When installing heated oxygen sensor 2, use heated oxygen sensor wrench (special service tool: KV10117200).

CAUTION:

- Do not apply impact while handling.
- Do not use heated oxygen sensor 2 after being dropped on a solid concrete floor, from a height of 0.5 m (1.6 ft) or higher. Replace it with a new one.
- Do not tighten heated oxygen sensor 2 to a torque larger than specified. Excess tightening may result in damage of heated oxygen sensor 2, causing MI to turn ON.
- when using heated oxygen sensor wrench (special service tool: KV10117200), tighten to the middle of specified torque because length of tool may induce slight indication increase. Do not tighten to the maximum specified torque.

Three Way Catalyst to Exhaust Front Tube

1. Securely insert seal bearing into three way catalyst side in the direction shown in figure.

CAUTION:

Be careful not to damage seal bearing surface when installing.

2. With spring large diameter side facing to exhaust front tube flange, tighten mounting bolt.
 - Be careful that mounting bolt does not interfere with flanged area, and tighten it.

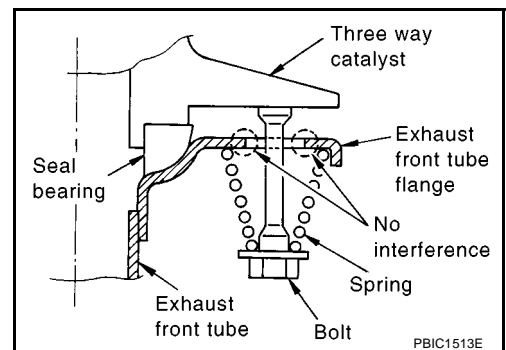

EXHAUST SYSTEM

Exhaust Front Tube to Center Muffler

1. Securely insert seal bearing into exhaust front tube side in the direction shown in figure.

CAUTION:

Be careful not to damage seal bearing surface when installing.

2. With spring large diameter side facing to center muffler flange, tighten mounting bolt.
 - Be careful that mounting bolt does not interfere with flanged area, and tighten it.

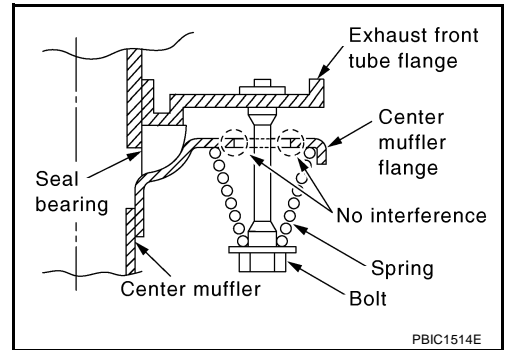

INSTALLATION (K9K ENGINE)

- Install in the reverse order of removal.

CAUTION:

- Always replace exhaust gaskets with new ones when reassembling.
- If the insulator is badly deformed, repair or replace it. If deposits such as mud pile up on the insulator, remove them.
- When installing the insulator avoid large gaps or interference between the insulator and each exhaust pipe.
- Remove deposits from the sealing surface of each connection. Connect them securely to avoid gas leakage.
- Temporarily tighten mounting nuts on the exhaust manifold side and mounting bolts on the vehicle side. Check each part for unusual interference, and then tighten them to the specified torque.
- When installing each mounting rubber, avoid twisting or unusual extension in up/down and right/left directions.

Inspection After Installation

BBS003Z7

- With the engine running, check exhaust tube joints for gas leakage and unusual noises.
- Check to ensure that mounting brackets and mounting insulators are installed properly and free from undue stress. Improper installation could result in excessive noise and vibration.

SERVICE DATA AND SPECIFICATIONS (SDS)

SERVICE DATA AND SPECIFICATIONS (SDS)

PFP:00030

Tightening Torque CR ENGINE

BBS003Z8

Unit: N·m (kg-m, ft-lb)
Unit: N·m (kg-m, in-lb)*

Exhaust system connecting parts	
Three way catalyst to Exhaust front tube	43.1 - 54.9 (4.4 - 5.6, 32 - 40)
Exhaust front tube to Center muffler	43.1 - 54.9 (4.4 - 5.6, 32 - 40)
Center muffler to Main muffler	30.4 - 39.2 (3.1 - 3.9, 23 - 28)
Heated oxygen sensor 2	40 - 60 (4.1 - 6.1, 30 - 44)
Exhaust front tube mounting bracket	16.4 - 20.7 (1.7 - 2.1, 12 - 15)
Ground cable	2.9 - 4.9 (0.3 - 0.49, 26 - 43)*

HR ENGINE

Unit: N·m (kg-m, ft-lb)
Unit: N·m (kg-m, in-lb)*

Exhaust system connecting parts	
Three way catalyst to Exhaust front tube	49.0 (5.0, 36)
Exhaust front tube to Center muffler	49.0 (5.0, 36)
Center muffler to Main muffler	34.8 (3.5, 26)
Heated oxygen sensor 2	50 (5.1, 37)
Ground cable	3.9 (0.4, 35)*

K9K ENGINE

Unit: N·m (kg-m, ft-lb)

Exhaust system connecting parts	
Catalyst to Exhaust front tube	17.9 - 24.2 (1.9 - 2.4, 14 - 17)
Exhaust front tube to Exhaust center tube	30.4 - 39.2 (3.1 - 3.9, 23 - 28)
Exhaust center tube to Main muffler	30.4 - 39.2 (3.1 - 3.9, 23 - 28)