

**SECTION BR**  
**BRAKE SYSTEM**

A  
B  
C  
D  
E

**CONTENTS**

<b>PRECAUTION</b> .....	<b>3</b>	<b>DISC ROTOR</b> .....	<b>14</b>	<b>BR</b>
<b>PRECAUTIONS</b> .....	<b>3</b>	DISC ROTOR : Inspection and Adjustment .....	14	
Precaution for Supplemental Restraint System (SRS) "AIR BAG" and "SEAT BELT PRE-TENSIONER" .....	3	<b>REAR DISC BRAKE</b> .....	<b>16</b>	<b>G</b>
Precaution for Procedure without Cowl Top Cover.....	3	<b>BRAKE PAD</b> .....	<b>16</b>	
Precaution for Brake System .....	3	BRAKE PAD : Inspection and Adjustment .....	16	<b>H</b>
Precautions for Removing of Battery Terminal .....	4	<b>DISC ROTOR</b> .....	<b>16</b>	
<b>PREPARATION</b> .....	<b>5</b>	DISC ROTOR : Inspection and Adjustment .....	16	<b>I</b>
<b>PREPARATION</b> .....	<b>5</b>	<b>REMOVAL AND INSTALLATION</b> .....	<b>18</b>	
Commercial Service Tool .....	5	<b>BRAKE PEDAL</b> .....	<b>18</b>	<b>J</b>
<b>SYMPTOM DIAGNOSIS</b> .....	<b>6</b>	Exploded View .....	18	
<b>NOISE, VIBRATION AND HARSHNESS (NVH) TROUBLESHOOTING</b> .....	<b>6</b>	Removal and Installation .....	18	<b>K</b>
NVH Troubleshooting Chart .....	6	Inspection and Adjustment .....	19	
<b>PERIODIC MAINTENANCE</b> .....	<b>7</b>	<b>BRAKE PIPING</b> .....	<b>21</b>	<b>L</b>
<b>BRAKE PEDAL</b> .....	<b>7</b>	<b>FRONT</b> .....	<b>21</b>	
Inspection and Adjustment .....	7	FRONT : Exploded View .....	21	<b>M</b>
<b>BRAKE FLUID</b> .....	<b>10</b>	FRONT : Hydraulic Piping .....	21	
Inspection .....	10	FRONT : Removal and Installation .....	22	<b>N</b>
Draining .....	10	FRONT : Inspection .....	24	
Refilling .....	10	<b>REAR</b> .....	<b>24</b>	<b>O</b>
Bleeding Brake System .....	11	REAR : Exploded View .....	24	
<b>BRAKE MASTER CYLINDER</b> .....	<b>12</b>	REAR : Hydraulic Piping .....	26	<b>P</b>
Inspection .....	12	REAR : Removal and Installation .....	27	
<b>BRAKE BOOSTER</b> .....	<b>13</b>	REAR : Inspection .....	32	
Inspection .....	13	<b>BRAKE MASTER CYLINDER</b> .....	<b>33</b>	
<b>FRONT DISC BRAKE</b> .....	<b>14</b>	Exploded View .....	33	
<b>BRAKE PAD</b> .....	<b>14</b>	Removal and Installation .....	33	
BRAKE PAD : Inspection and Adjustment .....	14	Disassembly and Assembly .....	35	
		Inspection .....	36	
		<b>BRAKE BOOSTER</b> .....	<b>37</b>	
		Exploded View .....	37	
		Removal and installation .....	37	
		Inspection and Adjustment .....	38	

<b>VACUUM LINES</b> .....	<b>40</b>	BRAKE PAD : Exploded View .....	50
Exploded View .....	40	BRAKE PAD : Removal and Installation .....	50
Removal and Installation .....	40	BRAKE PAD : Inspection .....	52
Inspection .....	40		
<b>FRONT DISC BRAKE</b> .....	<b>42</b>	<b>BRAKE CALIPER ASSEMBLY</b> .....	<b>52</b>
<b>BRAKE PAD</b> .....	<b>42</b>	BRAKE CALIPER ASSEMBLY : Exploded View ...	52
BRAKE PAD : Exploded View .....	42	BRAKE CALIPER ASSEMBLY : Removal and In-	53
BRAKE PAD : Removal and Installation .....	42	stallation .....	
BRAKE PAD : Inspection .....	44	BRAKE CALIPER ASSEMBLY : Disassembly and	54
		Assembly .....	
<b>BRAKE CALIPER ASSEMBLY</b> .....	<b>44</b>	BRAKE CALIPER ASSEMBLY : Inspection .....	56
BRAKE CALIPER ASSEMBLY : Exploded View ...	45		
BRAKE CALIPER ASSEMBLY : Removal and In-	46	<b>SERVICE DATA AND SPECIFICATIONS</b>	
stallation .....		<b>(SDS)</b> .....	<b>58</b>
BRAKE CALIPER ASSEMBLY : Disassembly and	47		
Assembly .....	47	<b>SERVICE DATA AND SPECIFICATIONS</b>	
BRAKE CALIPER ASSEMBLY : Inspection .....	49	<b>(SDS)</b> .....	<b>58</b>
		General Specifications .....	58
<b>REAR DISC BRAKE</b> .....	<b>50</b>	Brake Pedal .....	58
<b>BRAKE PAD</b> .....	<b>50</b>	Brake Booster .....	58
		Front Disc Brake .....	59
		Rear Disc Brake .....	59

# PRECAUTIONS

< PRECAUTION >

## PRECAUTION

### PRECAUTIONS

#### Precaution for Supplemental Restraint System (SRS) "AIR BAG" and "SEAT BELT PRE-TENSIONER"

INFOID:000000009752269

The Supplemental Restraint System such as "AIR BAG" and "SEAT BELT PRE-TENSIONER", used along with a front seat belt, helps to reduce the risk or severity of injury to the driver and front passenger for certain types of collision. This system includes seat belt switch inputs and dual stage front air bag modules. The SRS system uses the seat belt switches to determine the front air bag deployment, and may only deploy one front air bag, depending on the severity of a collision and whether the front occupants are belted or unbelted. Information necessary to service the system safely is included in the "SRS AIR BAG" and "SEAT BELT" of this Service Manual.

#### **WARNING:**

Always observe the following items for preventing accidental activation.

- To avoid rendering the SRS inoperative, which could increase the risk of personal injury or death in the event of a collision that would result in air bag inflation, all maintenance must be performed by an authorized NISSAN/INFINITI dealer.
- Improper maintenance, including incorrect removal and installation of the SRS, can lead to personal injury caused by unintentional activation of the system. For removal of Spiral Cable and Air Bag Module, see "SRS AIR BAG".
- Never use electrical test equipment on any circuit related to the SRS unless instructed to in this Service Manual. SRS wiring harnesses can be identified by yellow and/or orange harnesses or harness connectors.

#### PRECAUTIONS WHEN USING POWER TOOLS (AIR OR ELECTRIC) AND HAMMERS

#### **WARNING:**

Always observe the following items for preventing accidental activation.

- When working near the Air Bag Diagnosis Sensor Unit or other Air Bag System sensors with the ignition ON or engine running, never use air or electric power tools or strike near the sensor(s) with a hammer. Heavy vibration could activate the sensor(s) and deploy the air bag(s), possibly causing serious injury.
- When using air or electric power tools or hammers, always switch the ignition OFF, disconnect the battery, and wait at least 3 minutes before performing any service.

#### Precaution for Procedure without Cowl Top Cover

INFOID:000000009752270

When performing the procedure after removing cowl top cover, cover the lower end of windshield with urethane, etc to prevent damage to windshield.



#### Precaution for Brake System

INFOID:000000009752271

#### **WARNING:**

Since dust covering the front and rear brakes has an affect on human body, the dust must be removed with a dust collector. Never splatter the dust with an air blow gun.

- Brake fluid use refer to [MA-10, "Fluids and Lubricants"](#).
- Never reuse drained brake fluid.
- Never spill or splash brake fluid on painted surfaces. Brake fluid may seriously damage paint. Wipe it off immediately and wash with water if it gets on a painted surface. For brake component parts, never wash them with water.

# PRECAUTIONS

## < PRECAUTION >

- Always confirm the specified tightening torque when installing the brake pipes.
- After pressing the brake pedal more deeply or harder than normal driving, such as air bleeding, check each item of brake pedal. Adjust brake pedal if it is outside the standard value.
- Always clean with new brake fluid when cleaning the master cylinder, brake caliper and other components.
- Never use mineral oils such as gasoline or light oil to clean. They may damage rubber parts and cause improper operation.
- Always loosen the brake tube flare nut with a flare nut wrench.
- Tighten the brake tube flare nut to the specified torque with a crow-foot (A) and torque wrench (B).
- Turn the ignition switch OFF and disconnect the ABS actuator and electric unit (control unit) harness connector or the battery negative terminal before performing the work.
- Check that no brake fluid leakage is present after replacing the parts.
- Burnish the brake contact surfaces after refinishing or replacing rotors, after replacing pads, or if a soft pedal occurs at very low mileage.
- Front brake pad: Refer to [BR-14, "BRAKE PAD : Inspection and Adjustment"](#).
- Front disc rotor: Refer to [BR-14, "DISC ROTOR : Inspection and Adjustment"](#).
- Rear brake pad: Refer to [BR-16, "BRAKE PAD : Inspection and Adjustment"](#).
- Rear disc rotor: Refer to [BR-16, "DISC ROTOR : Inspection and Adjustment"](#).

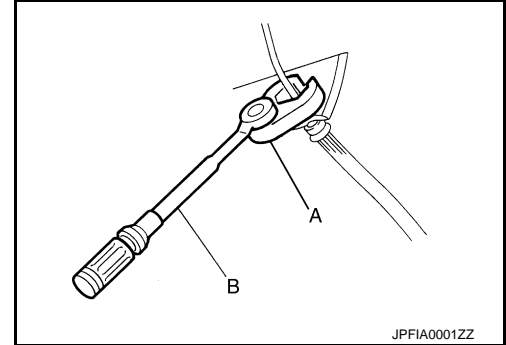

## Precautions for Removing of Battery Terminal

INFOID:000000010176373

- When removing the 12V battery terminal, turn OFF the ignition switch and wait at least 30 seconds.

### NOTE:

ECU may be active for several tens of seconds after the ignition switch is turned OFF. If the battery terminal is removed before ECU stops, then a DTC detection error or ECU data corruption may occur.

- For vehicles with the 2-batteries, be sure to connect the main battery and the sub battery before turning ON the ignition switch.

### NOTE:

If the ignition switch is turned ON with any one of the terminals of main battery and sub battery disconnected, then DTC may be detected.

- After installing the 12V battery, always check "Self Diagnosis Result" of all ECUs and erase DTC.

### NOTE:

The removal of 12V battery may cause a DTC detection error.

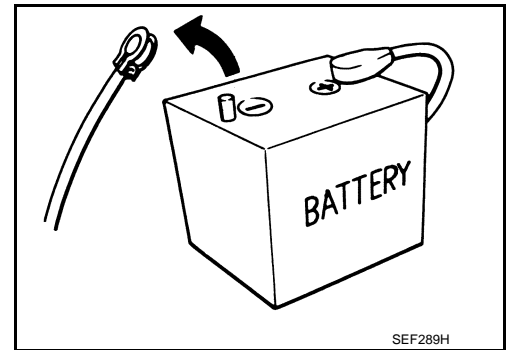

# PREPARATION



< PREPARATION >

## PREPARATION

### PREPARATION

#### Commercial Service Tool

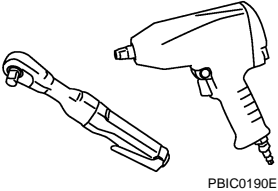
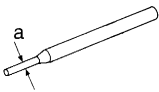
INFOID:000000009752272

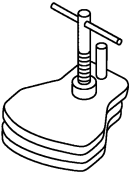
Tool name	Description
<p>Power tool</p>  <p>PBIC0190E</p>	<p>Loosening bolts and nuts</p>
<p>Pin punch a: 4 mm (0.16 in)</p>  <p>NT410</p>	<p>Removing and installing reservoir tank</p>
<p>Handy vacuum pump</p>  <p>ZZC1313D</p>	<ul style="list-style-type: none"> <li>• Air tight</li> <li>• Inspection of check valve</li> </ul>
<p>Brake caliper wrench</p>  <p>NNFIA0040ZZ</p>	<p>Return the piston</p>

A

B

C

D

E

BR

G

H

I

J

K

L

M

N

O

P



# BRAKE PEDAL

< PERIODIC MAINTENANCE >

## PERIODIC MAINTENANCE

### BRAKE PEDAL

#### Inspection and Adjustment

INFOID:000000009752274

#### INSPECTION

##### Brake Pedal Height

Check the height (H<sub>1</sub>) between the dash lower panel (1) and the brake pedal upper surface.

H<sub>1</sub> : Refer to [BR-58, "Brake Pedal"](#).

#### CAUTION:

Remove the floor trim.

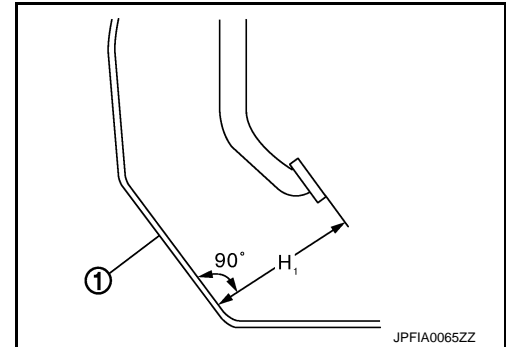

##### Stop Lamp Switch

Check the clearance (C) among the brake pedal lever (1) and the stop lamp switch (2) threaded end.

C : Refer to [BR-58, "Brake Pedal"](#).

#### CAUTION:

The stop lamp must turn off when the brake pedal is released.

#### NOTE:

Pull the brake pedal pad to make the clearance between the stop lamp switch threaded end and the brake pedal lever.

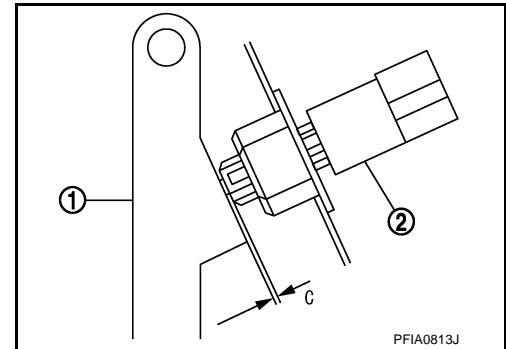

##### Brake Pedal Position Switch

Check the clearance (C) among the brake pedal lever (1) and the brake pedal position switch (2) threaded end.

C : Refer to [BR-58, "Brake Pedal"](#).

#### NOTE:

Pull the brake pedal pad to make the clearance between the brake pedal position switch threaded end and the brake pedal lever.

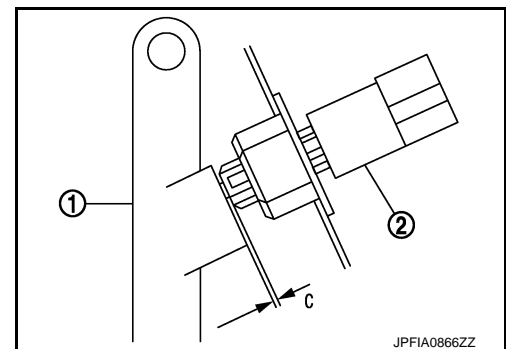

##### Brake Pedal Play

Press the brake pedal. Check the brake pedal play (A) (stroke until fluid pressure occurs).

A : Refer to [BR-58, "Brake Pedal"](#).

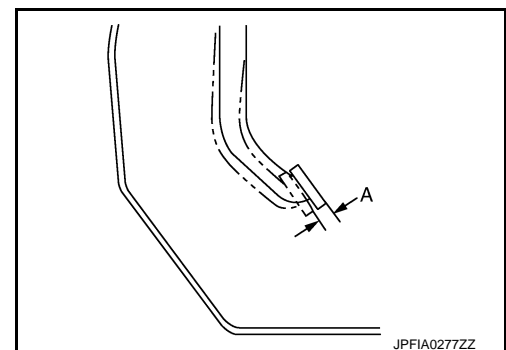

##### Depressed Brake Pedal Height

# BRAKE PEDAL

## < PERIODIC MAINTENANCE >

Check the height between the dash lower panel (1) and the brake pedal upper surface ( $H_2$ ) when depressing the brake pedal at 490 N (50 kg, 110 lb) while turning engine ON.

$H_2$  : Refer to [BR-58, "Brake Pedal"](#).

### CAUTION:

Remove the floor trim.

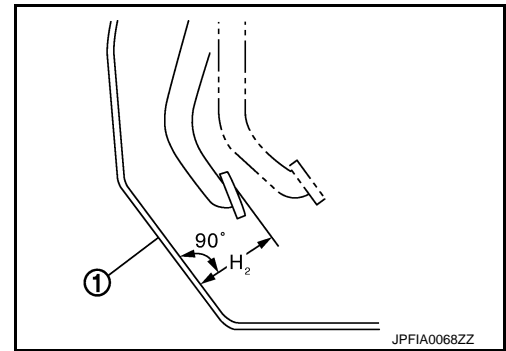

## ADJUSTMENT

### Brake Pedal Height

1. Remove instrument lower panel. Refer to [IP-13, "Removal and Installation"](#).
2. Disconnect the stop lamp switch and brake pedal position switch harness connector.
3. Loosen the stop lamp switch and brake pedal position switch 45° counterclockwise.
4. Loosen the lock nut (1) of input rod (2).
5. Rotate the input rod, adjust the brake pedal to the specified height ( $H_1$ ).

### CAUTION:

The threaded end of the input rod must project to the inner side (L) of the clevis (3).

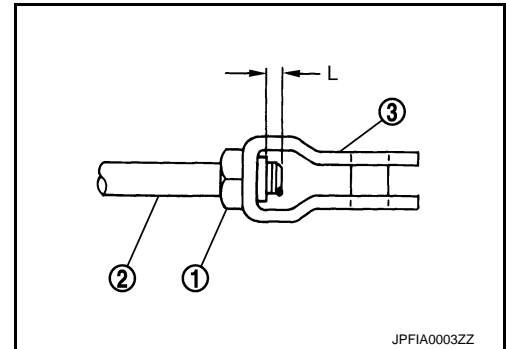

$H_1$  : Refer to [BR-58, "Brake Pedal"](#).

6. Tighten the lock nut. Refer to [BR-37, "Exploded View"](#).
7. Adjust the clearance between the brake pedal lever and the stop lamp switch threaded end after adjusting the brake pedal height.

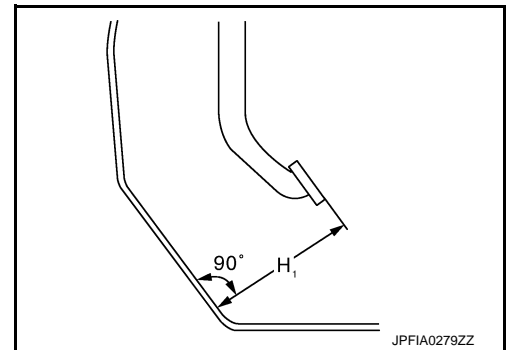

### Stop Lamp Switch

1. Remove instrument lower panel. Refer to [IP-13, "Removal and Installation"](#).
2. Disconnect the harness connector from stop lamp switch.
3. Loosen the stop lamp switch 45° counterclockwise.
4. Press-fit the stop lamp switch (2) until the stop lamp switch hits the brake pedal lever (1) 45° clockwise while pulling the brake pedal pad slightly.

### CAUTION:

• The clearance (C) between the brake pedal lever and stop lamp switch threaded end must be the specified value.

C : Refer to [BR-58, "Brake Pedal"](#).

• The stop lamp must be turned off when the brake pedal is released.

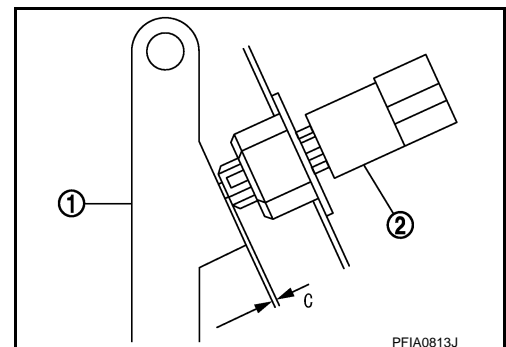

### Brake Pedal Position Switch



# BRAKE PEDAL

## < PERIODIC MAINTENANCE >

1. Remove instrument lower panel. Refer to [IP-13, "Removal and Installation"](#).
2. Disconnect the harness connector from brake pedal position switch.
3. Loosen the brake pedal position switch 45° counterclockwise.
4. Press-fit the brake pedal position switch (2) until the brake pedal position switch hits the brake pedal lever (1) 45° clockwise while pulling the brake pedal pad slightly.

**CAUTION:**

The clearance (C) between the brake pedal lever and brake pedal position switch threaded end must be the specified value.

**C** : Refer to [BR-58, "Brake Pedal"](#).

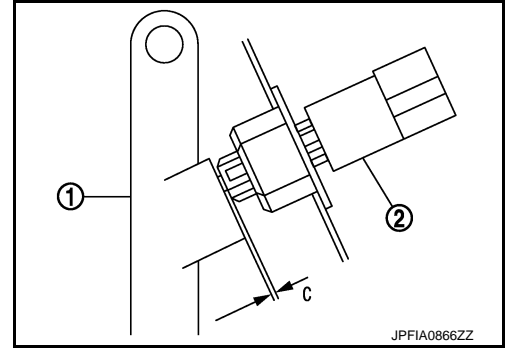

### Depressed Brake Pedal Height

1. Perform the air bleeding. Refer to [BR-11, "Bleeding Brake System"](#).
2. Check the height between the dash lower panel (1) and the brake pedal upper surface (H<sub>2</sub>) when depressing the brake pedal at 490 N (50 kg, 110 lb) while turning engine ON.

**H<sub>2</sub>** : Refer to [BR-58, "Brake Pedal"](#).

**CAUTION:**

Remove the floor trim.

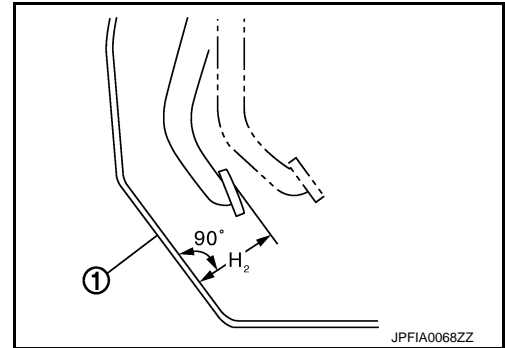

A  
B  
C  
D  
E  
BR  
G  
H  
I  
J  
K  
L  
M  
N  
O  
P

# BRAKE FLUID

< PERIODIC MAINTENANCE >

## BRAKE FLUID

### Inspection

INFOID:000000009752275

#### BRAKE FLUID LEVEL

- Check that the fluid level in the reservoir tank is within the specified range (MAX – MIN lines).
- Visually check for any brake fluid leakage around the reservoir tank.
- Check the brake system for any leakage if the fluid level is extremely low (lower than MIN).
- Check the brake system for fluid leakage if the warning lamp remains illuminated even after the parking brake is released.
- Check the reservoir tank for the mixing of foreign matter (e.g. dust) and oils other than brake fluid.

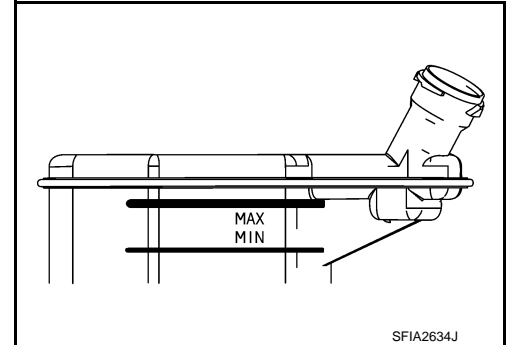

#### BRAKE LINE

1. Check brake line (tubes and hoses) for cracks, deterioration or other damage. Replace any damaged parts.
2. Depress the brake pedal with a force of 785 N (80 kg, 176 lb) and hold down the pedal for approximately 5 seconds with the engine running. Check for any fluid leakage.

#### **CAUTION:**

**Retighten the applicable connection to the specified torque and repair any abnormal (damaged, worn or deformed) part if any brake fluid leakage is present.**

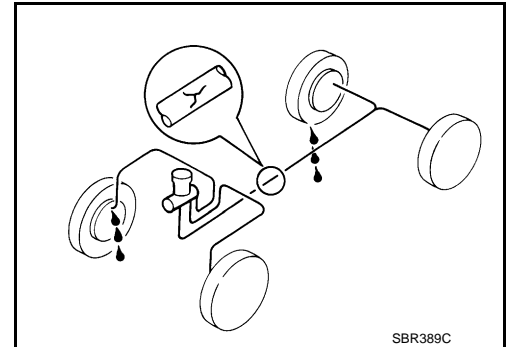

### Draining

INFOID:000000009752276

#### **CAUTION:**

- **Never spill or splash brake fluid on painted surfaces. Brake fluid may seriously damage paint. Wipe it off immediately and wash with water if it gets on a painted surface. For brake component parts, never wash them with water.**
- **Turn the ignition switch OFF and disconnect the ABS actuator and electric unit (control unit) harness connector or the battery negative terminal before performing work.**

1. Connect a vinyl tube to the bleed valve.
2. Depress the brake pedal and loosen the bleeder valve to gradually discharge brake fluid.

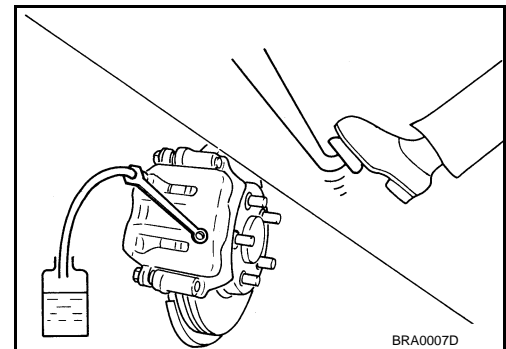

### Refilling

INFOID:000000009752277

#### **CAUTION:**

- **Turn the ignition switch OFF and disconnect the ABS actuator and electric unit (control unit) harness connector or the battery negative terminal before performing work.**

# BRAKE FLUID

## < PERIODIC MAINTENANCE >

- **Never spill or splash brake fluid on painted surfaces. Brake fluid may seriously damage paint. Wipe it off immediately and wash with water if it gets on a painted surface. For brake component parts, never wash them with water.**
1. Check that there is no foreign material in the reservoir tank, and refill with new brake fluid.  
**CAUTION:**
    - **Never reuse drained brake fluid.**
    - **Never allow foreign matter (e.g. dust) and oils other than brake fluid to enter the reservoir tank.**
  2. Loosen the bleeder valve, slowly depress the brake pedal to the full stroke, and then release the pedal. Repeat this operation at intervals of 2 or 3 seconds until new brake fluid is discharged. Then close the bleeder valve with the brake pedal depressed. Repeat the same work on each wheel.
  3. Perform the air bleeding. Refer to [BR-11, "Bleeding Brake System"](#).

## Bleeding Brake System

INFOID:000000009752278

### **CAUTION:**

- **Turn the ignition switch OFF and disconnect the ABS actuator and electric unit (control unit) harness connector or the battery negative terminal before performing the work.**
- **Monitor the fluid level in the reservoir tank while performing the air bleeding**
- **Never spill or splash brake fluid on painted surfaces. Brake fluid may seriously damage paint. Wipe it off immediately and wash with water if it gets on a painted surface. For brake component parts, never wash them with water.**

1. Check that there is no foreign material in the reservoir tank, and refill with new brake fluid.  
**CAUTION:**
  - **Never reuse drained brake fluid.**
  - **Never allow oils other than brake fluid to enter the reservoir tank.**
2. Connect a vinyl tube to the bleeder valve of the rear right brake.
3. Fully depress the brake pedal 4 to 5 times.
4. Loosen the bleeder valve and bleed air with the brake pedal depressed, and then quickly tighten the bleeder valve.
5. Repeat steps 3 and 4 until all of the air is out of the brake line.
6. Tighten the bleeder valve to the specified torque.
  - Front disc brake: Refer to [BR-45, "BRAKE CALIPER ASSEMBLY : Exploded View"](#).
  - Rear disc brake: Refer to [BR-52, "BRAKE CALIPER ASSEMBLY : Exploded View"](#).
7. Perform steps 2 to 6. Occasionally fill with the brake fluid in order to keep it in the reservoir tank at least half of MAX line. Bleed air in the following order: rear right brake → front left brake → rear left brake → and front right brake in order.
8. Check that the fluid level in the reservoir tank is within the specified range after air bleeding. Refer to [BR-10, "Inspection"](#).
9. Check each item of brake pedal. Adjust it if the measurement value is not the standard. Refer to [BR-7, "Inspection and Adjustment"](#).

# BRAKE MASTER CYLINDER

< PERIODIC MAINTENANCE >

---

## BRAKE MASTER CYLINDER

### Inspection

*INFOID:000000009752279*

#### FLUID LEAK

Check for brake fluid leakage from the master cylinder mounting face, reservoir tank mounting face and brake tube connections.

# BRAKE BOOSTER

< PERIODIC MAINTENANCE >

## BRAKE BOOSTER

### Inspection

INFOID:000000009752280

### OPERATION

Depress the brake pedal several times at 5-second intervals with the engine stopped. Start the engine with the brake pedal fully depressed. Check that the clearance between brake pedal and dash lower panel decreases.

#### **NOTE:**

A slight impact with a small click may be felt on the pedal when the brake pedal is fully depressed. This is a normal phenomenon due to the brake system operation.

### AIR TIGHT

1. Run the engine at idle for 1 minute to apply vacuum to the brake booster, and stop the engine.
2. Depress the brake pedal several times at 5-second intervals until the accumulated vacuum is released to atmospheric pressure. Check that the clearance between brake pedal and dash lower panel gradually increases each time the brake pedal is depressed when performing this operation.
3. Depress the brake pedal with the engine running. Then stop the engine while holding down the brake pedal. Check that the brake pedal stroke does not change after holding down the brake pedal for 30 seconds or more.

A  
B  
C  
D  
E  
BR  
G  
H  
I  
J  
K  
L  
M  
N  
O  
P

# FRONT DISC BRAKE

< PERIODIC MAINTENANCE >

## FRONT DISC BRAKE

### BRAKE PAD

#### BRAKE PAD : Inspection and Adjustment

INFOID:000000009752281

#### INSPECTION

Check brake pad wear thickness from an inspection hole on cylinder body. Check using a scale if necessary.

**Wear thickness** : Refer to [BR-59, "Front Disc Brake"](#).

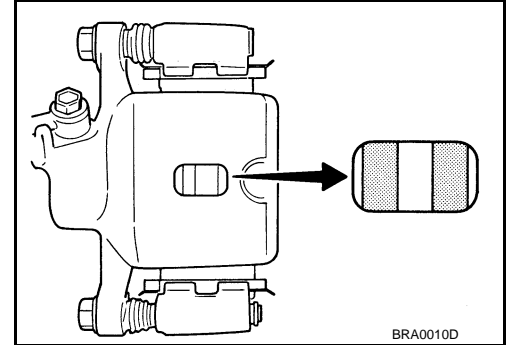

#### ADJUSTMENT

Burnish contact surfaces between disc rotor and brake pads according to the following procedure after refinishing or replacing brake pads, or if a soft pedal occurs at very low mileage.

#### CAUTION:

- Be careful of vehicle speed because the brake does not operate firmly/securely until pads and disc rotor are securely fitted.
- Only perform this procedure under safe road and traffic conditions. Use extreme caution.

1. Drive vehicle on straight, flat road.
2. Depress brake pedal with the power to stop vehicle within 3 to 5 seconds until the vehicle stops.
3. Drive without depressing brake for a few minutes to cool the brake.
4. Repeat steps 1 to 3 until pad and disc rotor are securely fitted.

### DISC ROTOR

#### DISC ROTOR : Inspection and Adjustment

INFOID:000000009752282

#### INSPECTION

##### Appearance

Check surface of disc rotor for uneven wear, cracks, and serious damage. Replace it if necessary. Refer to [FAX-9, "Removal and Installation"](#).

##### Runout

1. Fix the disc rotor to the wheel hub and bearing assembly with wheel nuts (2 points at least).
2. Check the wheel bearing axial end play before the inspection. Refer to [FAX-7, "Inspection"](#).
3. Inspect the runout with a dial indicator to measure at 10 mm (0.39 in) inside the disc edge.

**Runout (with it attached to the vehicle)** : Refer to [BR-59, "Front Disc Brake"](#).

4. Find the installation position that has a minimum runout by shifting the disc rotor-to-wheel hub and bearing assembly installation position by one hole at a time if the runout exceeds the limit value.

• Refinish the disc rotor if the runout is outside the limit even after performing the above operation. [When refinishing, use the Pro-Cut PEM On-Car brake Lathe (Tool No. 38-PFM90.5) or equivalent.]

#### CAUTION:

- Check in advance that the thickness of the disc rotor is wear thickness + 0.3 mm (0.012 in) or more.

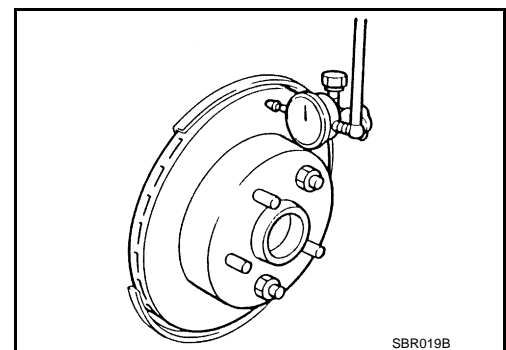

# FRONT DISC BRAKE

## < PERIODIC MAINTENANCE >

- If the thickness is less than wear thickness + 0.3 mm (0.012 in), replace the disc rotor. Refer to [FAX-9, "Removal and Installation"](#).

**Wear thickness** : Refer to [BR-59, "Front Disc Brake"](#).

### Thickness

Check the thickness of the disc rotor using a micrometer. Replace the disc rotor if the thickness is below the wear limit. Refer to [FAX-9, "Removal and Installation"](#).

**Wear thickness** : Refer to [BR-59, "Front Disc Brake"](#).

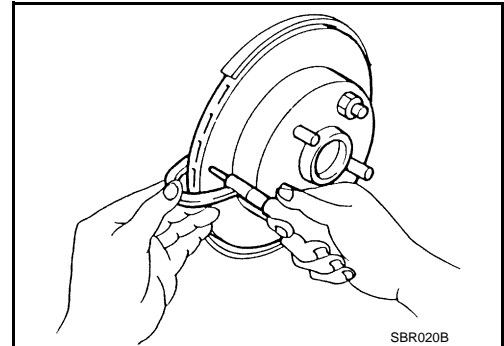

## ADJUSTMENT

Burnish contact surfaces between disc rotors and brake pads according to the following procedure after refinishing or replacing disc rotor, or if a soft pedal occurs at very low mileage.

### CAUTION:

- **Be careful of vehicle speed because the brake does not operate firmly/securely until pad and disc rotor are securely fitted.**
  - **Only perform this procedure under safe road and traffic conditions. Use extreme caution.**
1. Drive vehicle on straight, flat road.
  2. Depress brake pedal with the power to stop vehicle within 3 to 5 seconds until the vehicle stops.
  3. Drive without depressing brake for a few minutes to cool the brake.
  4. Repeat steps 1 to 3 until pad and disc rotor are securely fitted.

# REAR DISC BRAKE

< PERIODIC MAINTENANCE >

## REAR DISC BRAKE

### BRAKE PAD

#### BRAKE PAD : Inspection and Adjustment

INFOID:000000009752283

#### INSPECTION

Check brake pad wear thickness from an inspection hole on cylinder body. Check using a scale if necessary.

**Wear thickness** : Refer to [BR-59, "Rear Disc Brake"](#).

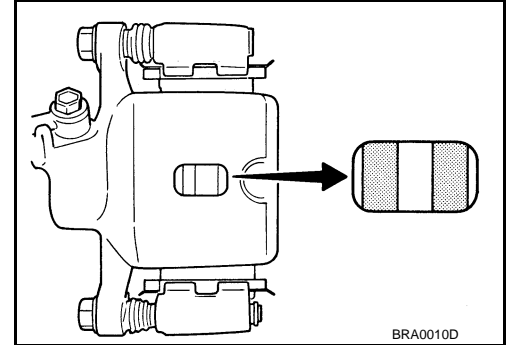

#### ADJUSTMENT

Burnish contact surfaces between disc rotor and brake pads according to the following procedure after refinishing or replacing brake pads, or if a soft pedal occurs at very low mileage.

#### CAUTION:

- Be careful of vehicle speed because the brake does not operate firmly/securely until pads and disc rotor are securely fitted.
- Only perform this procedure under safe road and traffic conditions. Use extreme caution.

1. Drive vehicle on straight, flat road.
2. Depress brake pedal with the power to stop vehicle within 3 to 5 seconds until the vehicle stops.
3. Drive without depressing brake for a few minutes to cool the brake.
4. Repeat steps 1 to 3 until pad and disc rotor are securely fitted.

### DISC ROTOR

#### DISC ROTOR : Inspection and Adjustment

INFOID:000000009752284

#### INSPECTION

##### Appearance

Check surface of disc rotor for uneven wear, cracks, and serious damage. Replace it if necessary.

- 2WD: Refer to [RAX-7, "Removal and Installation"](#).
- AWD: Refer to [RAX-16, "Removal and Installation"](#).

##### Runout

1. Fix the disc rotor to the wheel hub and bearing assembly with wheel nuts (2 points at least).
2. Check the wheel bearing axial end play before the inspection.
  - 2WD: Refer to [RAX-6, "Inspection"](#).
  - AWD: Refer to [RAX-14, "Inspection"](#).
3. Inspect the runout with a dial indicator to measure at 10 mm (0.39 in) inside the disc edge.

**Runout (with it attached to the vehicle)** : Refer to [BR-59, "Rear Disc Brake"](#).

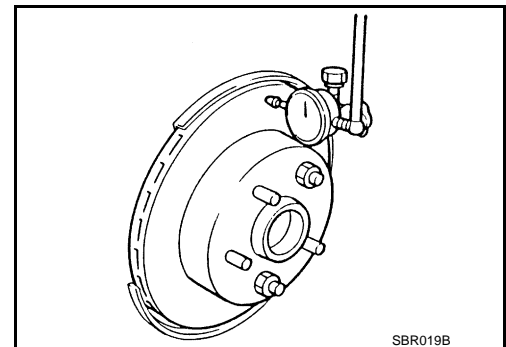

4. Find the installation position that has a minimum runout by shifting the disc rotor-to-wheel hub and bearing assembly installation position by one hole at a time if the runout exceeds the limit value.
- Refinish the disc rotor if the runout is outside the limit even after performing the above operation. [When refinishing, use the Pro-Cut PEM On-Car brake Lathe (Tool No. 38-PFM90.5) or equivalent.]

#### CAUTION:



# REAR DISC BRAKE

## < PERIODIC MAINTENANCE >

- Check in advance that the thickness of the disc rotor is wear thickness + 0.3 mm (0.012 in) or more.
- If the thickness is less than wear thickness + 0.3 mm (0.012 in), replace the disc rotor.
- 2WD: Refer to [RAX-7, "Removal and Installation"](#).
- AWD: Refer to [RAX-16, "Removal and Installation"](#).

**Wear thickness** : Refer to [BR-59, "Rear Disc Brake"](#).

### Thickness

Check the thickness of the disc rotor using a micrometer. Replace the disc rotor if the thickness is below the wear limit.

- 2WD: Refer to [RAX-7, "Removal and Installation"](#).
- AWD: Refer to [RAX-16, "Removal and Installation"](#).

**Wear thickness** : Refer to [BR-59, "Rear Disc Brake"](#).

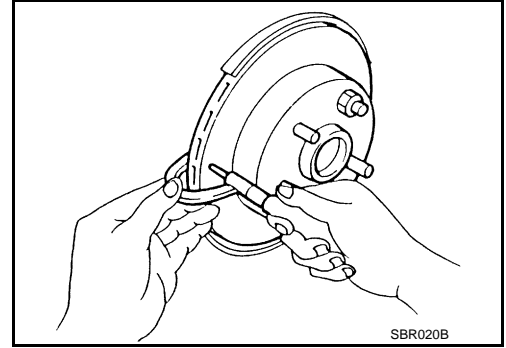

## ADJUSTMENT

Burnish contact surfaces between disc rotors and brake pads according to the following procedure after refinishing or replacing disc rotor, or if a soft pedal occurs at very low mileage.

### CAUTION:

- Be careful of vehicle speed because the brake does not operate firmly/securely until pad and disc rotor are securely fitted.
  - Only perform this procedure under safe road and traffic conditions. Use extreme caution.
1. Drive vehicle on straight, flat road.
  2. Depress brake pedal with the power to stop vehicle within 3 to 5 seconds until the vehicle stops.
  3. Drive without depressing brake for a few minutes to cool the brake.
  4. Repeat steps 1 to 3 until pad and disc rotor are securely fitted.

# BRAKE PEDAL

< REMOVAL AND INSTALLATION >

## REMOVAL AND INSTALLATION

### BRAKE PEDAL

Exploded View

INFOID:000000009752285

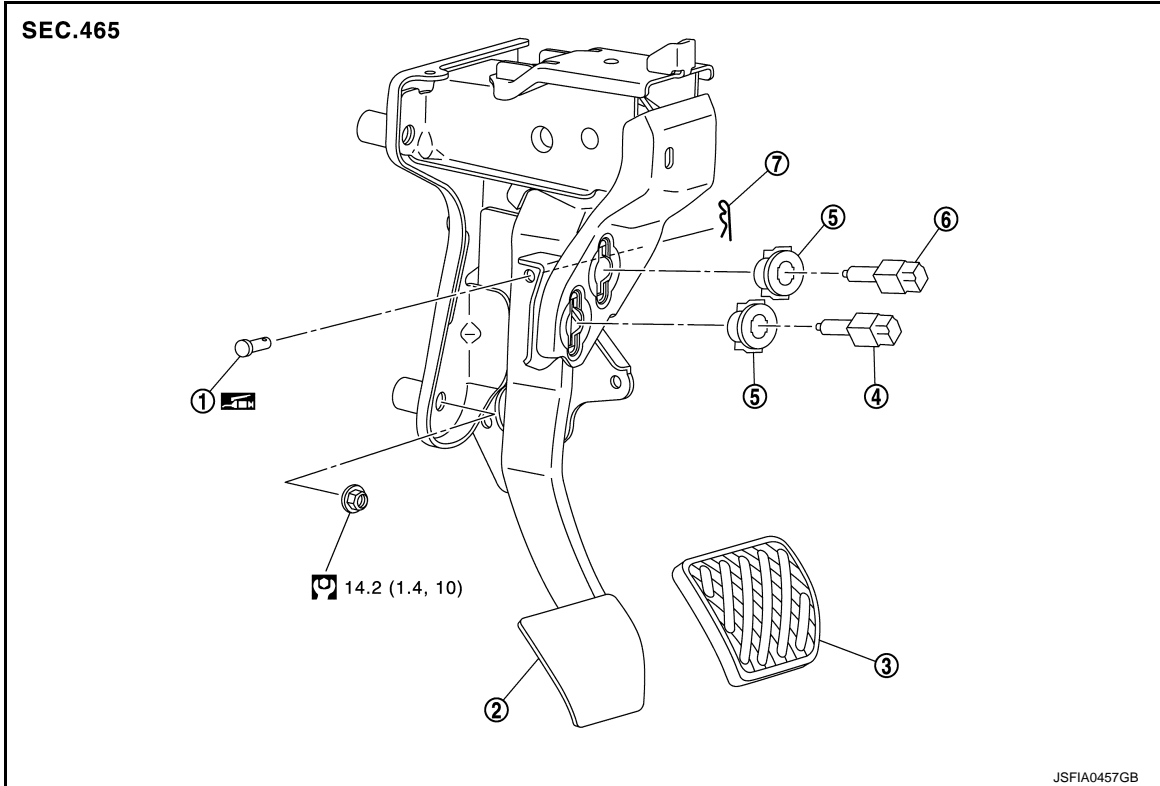

- |                                |                         |                     |
|--------------------------------|-------------------------|---------------------|
| 1. Clevis pin                  | 2. Brake pedal assembly | 3. Brake pedal pad  |
| 4. Brake pedal position switch | 5. Clip                 | 6. Stop lamp switch |
| 7. Snap pin                    |                         |                     |

: Apply multi-purpose grease.

: N·m (kg·m, ft·lb)

## Removal and Installation

INFOID:000000009752286

### REMOVAL

1. Remove instrument lower panel. Refer to [IP-13, "Removal and Installation"](#).
2. Disconnect the stop lamp switch and the brake pedal position switch harness connectors.
3. Rotate the stop lamp switch and the brake pedal position switch (1) counter clockwise to remove.
4. Disconnect the accelerator pedal harness connector and harness clip.

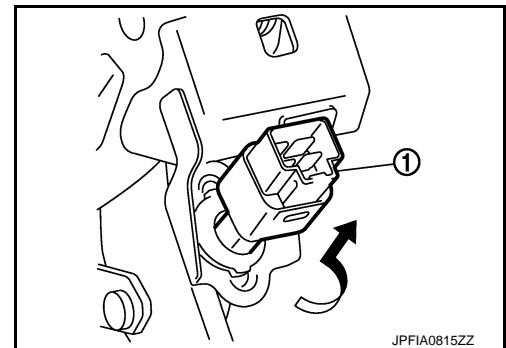

# BRAKE PEDAL

## < REMOVAL AND INSTALLATION >

5. Remove snap pin (1) and clevis pin (2) from clevis (3) of brake booster.

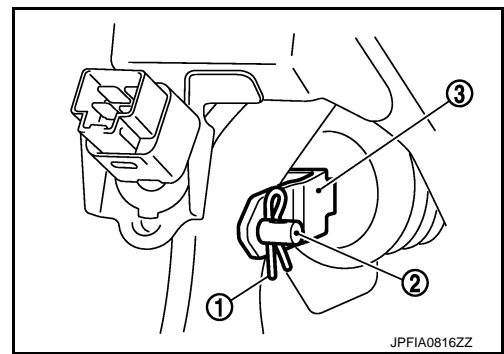

6. Remove the steering member stay (1).
7. Remove the brake pedal assembly.  
**CAUTION:**  
Hold the brake booster and master cylinder assembly so as not to drop out or contact them other parts.
8. Remove accelerator pedal from brake pedal assembly. Refer to [ACC-3, "Removal and Installation"](#).
9. Perform inspection after removal. Refer to [BR-19, "Inspection and Adjustment"](#).

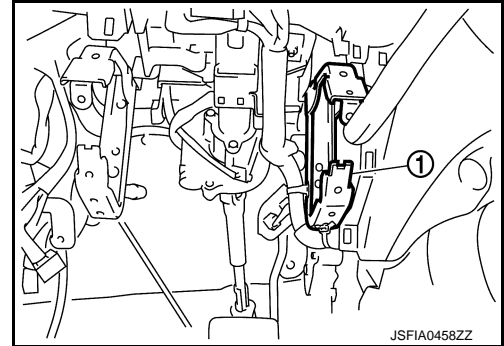

## INSTALLATION

Note the following, and install in the reverse order of removal.

- Apply the multi-purpose grease to the clevis pin and the mating faces. (Not necessary if grease has been already applied)

### NOTE:

The clevis pin may be inserted in either direction.

- Perform adjustment after installation. Refer to [BR-19, "Inspection and Adjustment"](#).

## Inspection and Adjustment

INFOID:000000009752287

## INSPECTION AFTER REMOVAL

- Check for the following items and replace the brake pedal assembly if necessary.
  - Check the brake pedal upper rivet (made by aluminum) (A) for deformation.
  - Check the brake pedal for bend, damage, and cracks on the welded parts.
  - Check the lapping length (D) of sub-bracket (B) and slide plate (C).

**D : 6.5 mm (0.256 in) or more**

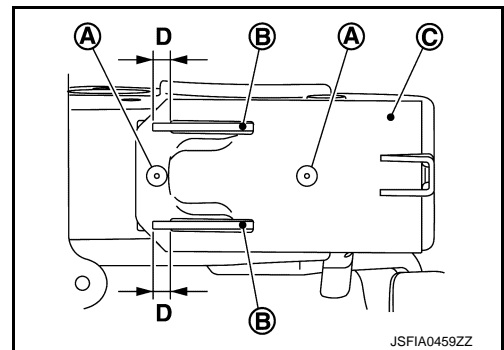

- Check clevis pin and plastic stopper (A) for damage and deformation. If any is found, replace clevis pin.

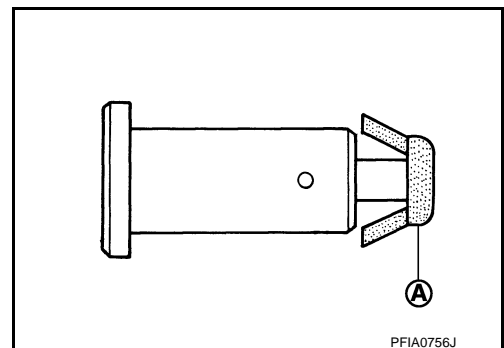

## BRAKE PEDAL

< REMOVAL AND INSTALLATION >

---

### ADJUSTMENT AFTER INSTALLATION

- Adjust each item of brake pedal after installing the brake pedal assembly to the vehicle. Refer to [BR-7. "Inspection and Adjustment"](#).
- Perform the release position learning of the accelerator pedal. Refer to [EC-143. "Work Procedure"](#).

# BRAKE PIPING

< REMOVAL AND INSTALLATION >

## BRAKE PIPING FRONT

### FRONT : Exploded View

INFOID:000000009752288

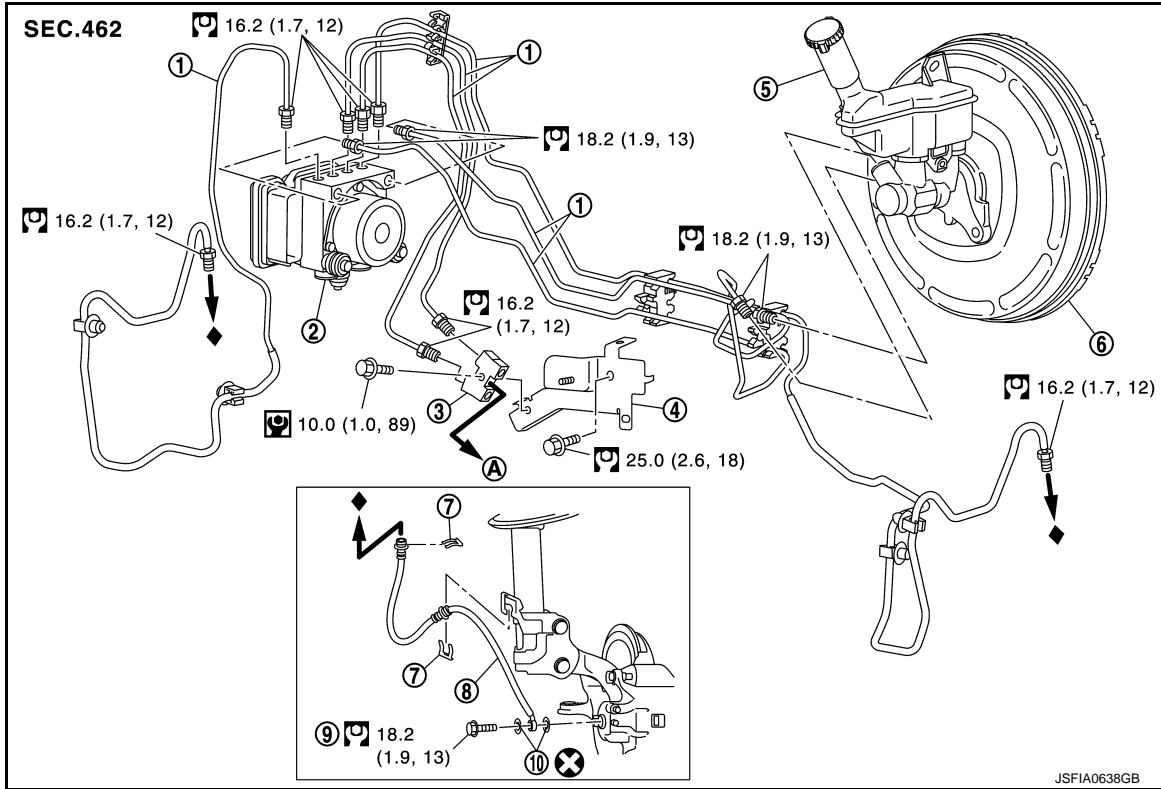

- |                       |  |                  |
|-----------------------|--|------------------|
| 1. Brake tube         | 2. ABS actuator and electric unit (control unit) | 3. Connector     |
| 4. Connector bracket  | 5. Master cylinder assembly                      | 6. Brake booster |
| 7. Lock plate         | 8. Brake hose                                    | 9. Union bolt    |
| 10. Copper washer     |  |                  |
| A. To rear brake tube |  |                  |

: N·m (kg-m, ft-lb)

: N·m (kg-m, in-lb)

: Always replace after every disassembly.

: Indicates that the part is connected at points with same symbol in actual vehicle.

### FRONT : Hydraulic Piping

INFOID:000000009752289

2WD

# BRAKE PIPING

## < REMOVAL AND INSTALLATION >

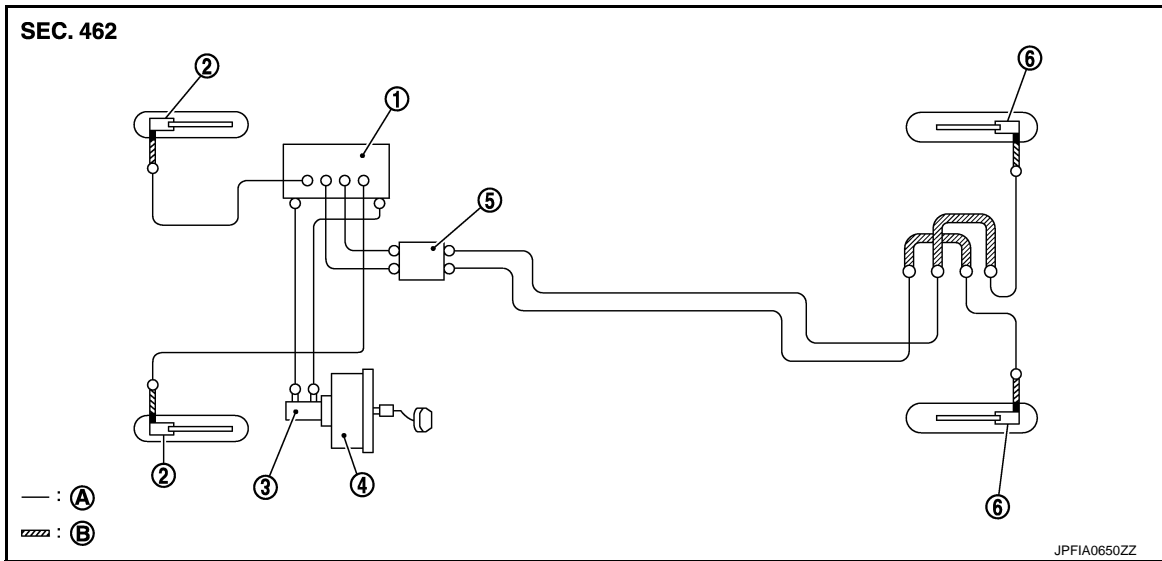

- |  |                     |                             |
|--|---------------------|-----------------------------|
| 1. ABS actuator and electric unit (control unit) | 2. Front disc brake | 3. Master cylinder assembly |
| 4. Brake booster                                 | 5. Connector        | 6. Rear disc brake          |
| A. Brake tube                                    | B. Brake hose       |                             |

○: Flare nut

■: Union bolt

AWD

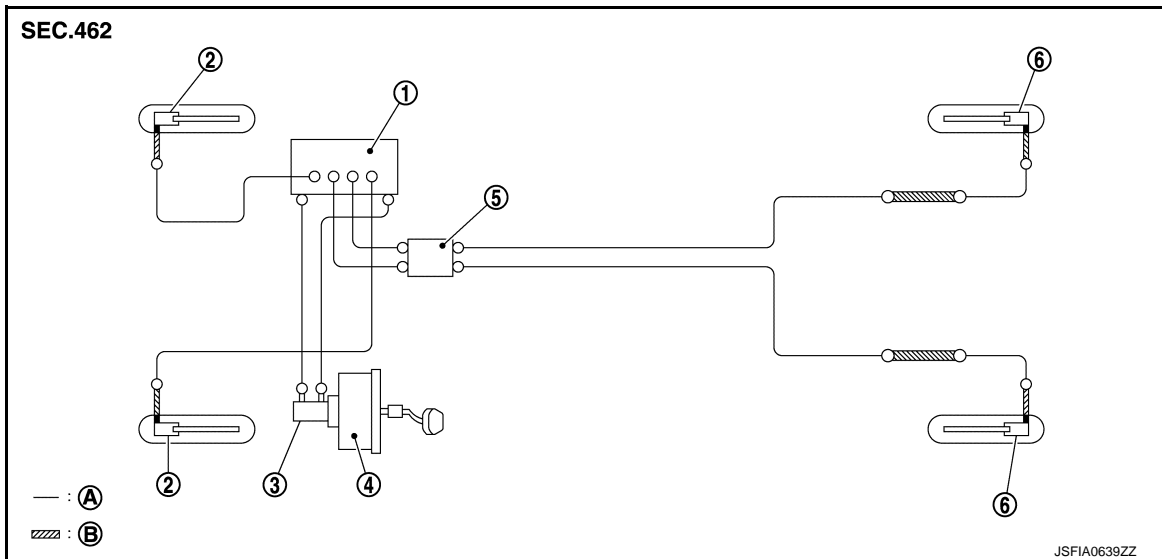

- |  |                     |                             |
|--|---------------------|-----------------------------|
| 1. ABS actuator and electric unit (control unit) | 2. Front disc brake | 3. Master cylinder assembly |
| 4. Brake booster                                 | 5. Connector        | 6. Rear disc brake          |
| A. Brake tube                                    | B. Brake hose       |                             |

○: Flare nut

■: Union bolt

## FRONT : Removal and Installation

INFOID:000000009752290

## REMOVAL

# BRAKE PIPING

## < REMOVAL AND INSTALLATION >

### CAUTION:

- Never spill or splash brake fluid on painted surfaces. Brake fluid may seriously damage paint. Wipe it off immediately and wash with water if it gets on a painted surface. For brake component parts, never wash them with water.
- Never depress the brake pedal while removing the brake hose or brake tube. If this is not complied with, brake fluid may splash.

1. Remove tires with power tool.
2. Drain brake fluid. Refer to [BR-10, "Draining"](#).
3. Loosen the flare nut (1) with a flare nut wrench (A) and separate the brake tube (2) from the brake hose (3).

### CAUTION:

- Never scratch the flare nut and the brake tube.
- Never bend sharply, twist or strongly pull out the brake hoses and tubes.
- Cover open end of brake tubes and hoses when disconnecting to prevent entrance of dirt.

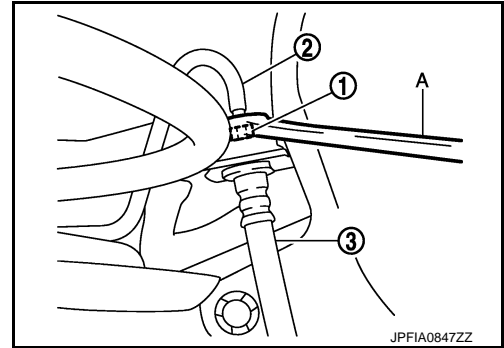

4. Remove the union bolt (1) and copper washers (2), and remove the brake hose (3) from the brake caliper assembly.
5. Remove the lock plate (4) and remove the brake hose.

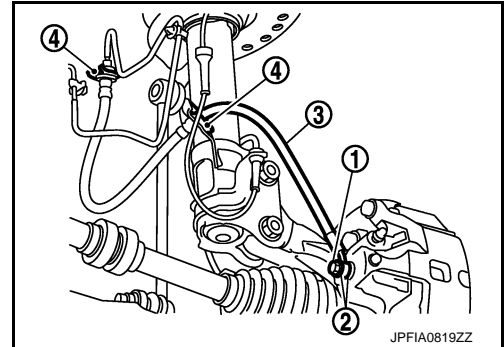

## INSTALLATION

### CAUTION:

- Never spill or splash brake fluid on painted surfaces. Brake fluid may seriously damage paint. Wipe it off immediately and wash with water if it gets on a painted surface. For brake component parts, never wash them with water.
- Never depress the brake pedal while removing the brake hose or brake tube. If this is not complied with, brake fluid may splash.

1. Assemble the union bolt (1) and the copper washer (2) to the brake hose.

### CAUTION:

Never reuse the copper washer.

2. Align the brake hose pin (A) with the brake caliper assembly projection (B), and tighten the union bolt (1) to the specified torque.

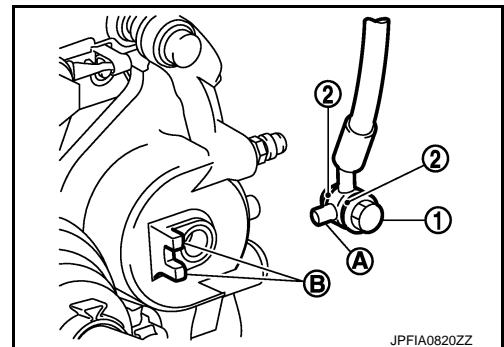

# BRAKE PIPING

## < REMOVAL AND INSTALLATION >

3. Install the brake tube (2) to the brake hose (1), temporarily tighten the flare nut (3) by hand until it does not rotate further, and fix the brake hose to the bracket (5) with the lock plate (4).

**CAUTION:**

**Check that all brake hoses and brake tubes are not twisted and bent.**

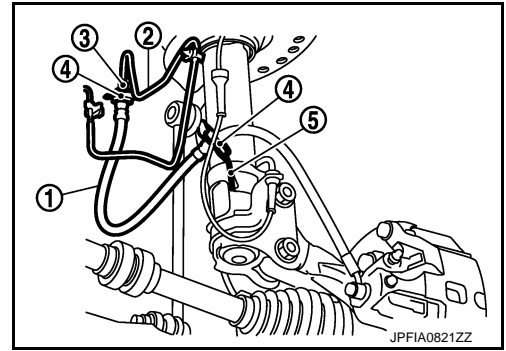

4. Tighten the flare nut to the specified torque with a crowfoot (A) and torque wrench (B).

**CAUTION:**

**Never scratch the flare nut and the brake tube.**

5. Refill with new brake fluid and perform the air bleeding. Refer to [BR-11, "Bleeding Brake System"](#).

**CAUTION:**

**Never reuse drained brake fluid.**

6. Install tires. Refer to [WT-46, "Removal and Installation"](#).
7. Perform inspection after installation. Refer to [BR-24, "FRONT : Inspection"](#).

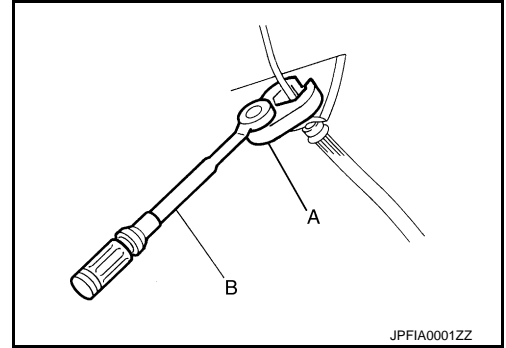

## FRONT : Inspection

INFOID:000000009752291

## INSPECTION AFTER INSTALLATION

1. Check the brake hoses and tubes for the following: no scratches; no twist and deformation; no interference with other components when steering the steering wheel; no looseness at connections.
2. Depress the brake pedal with a force of 785 N (80 kg, 176 lb) and hold down the pedal for approximately 5 seconds with the engine running. Check for any fluid leakage.

**CAUTION:**

**Retighten the applicable connection to the specified torque and repair any abnormal (damaged, worn or deformed) part if any brake fluid leakage is present.**

## REAR

## REAR : Exploded View

INFOID:000000009752292

## 2WD



# BRAKE PIPING

## < REMOVAL AND INSTALLATION >

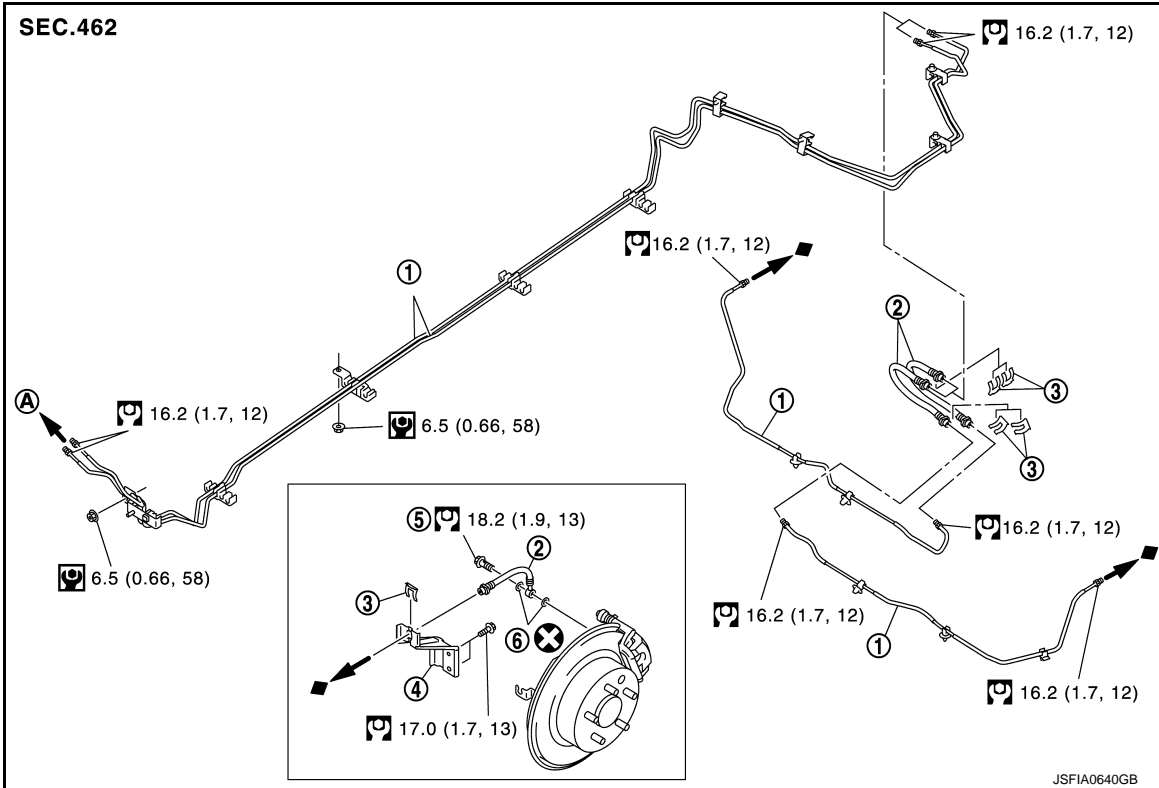

- |                       |                 |                 |
|-----------------------|-----------------|-----------------|
| 1. Brake tube         | 2. Brake hose A | 3. Lock plate   |
| 4. Brake hose bracket | 5. Union bolt   | 6. Brake hose B |
| 7. Copper washer      |                 |                 |
| A. To connector       |                 |                 |

: N·m (kg-m, ft-lb)

: N·m (kg-m, in-lb)

: Always replace after every disassembly.

: Indicates that the part is connected at points with same symbol in actual vehicle.

AWD

A  
B  
C  
D  
E  
BR  
G  
H  
I  
J  
K  
L  
M  
N  
O  
P

# BRAKE PIPING

< REMOVAL AND INSTALLATION >

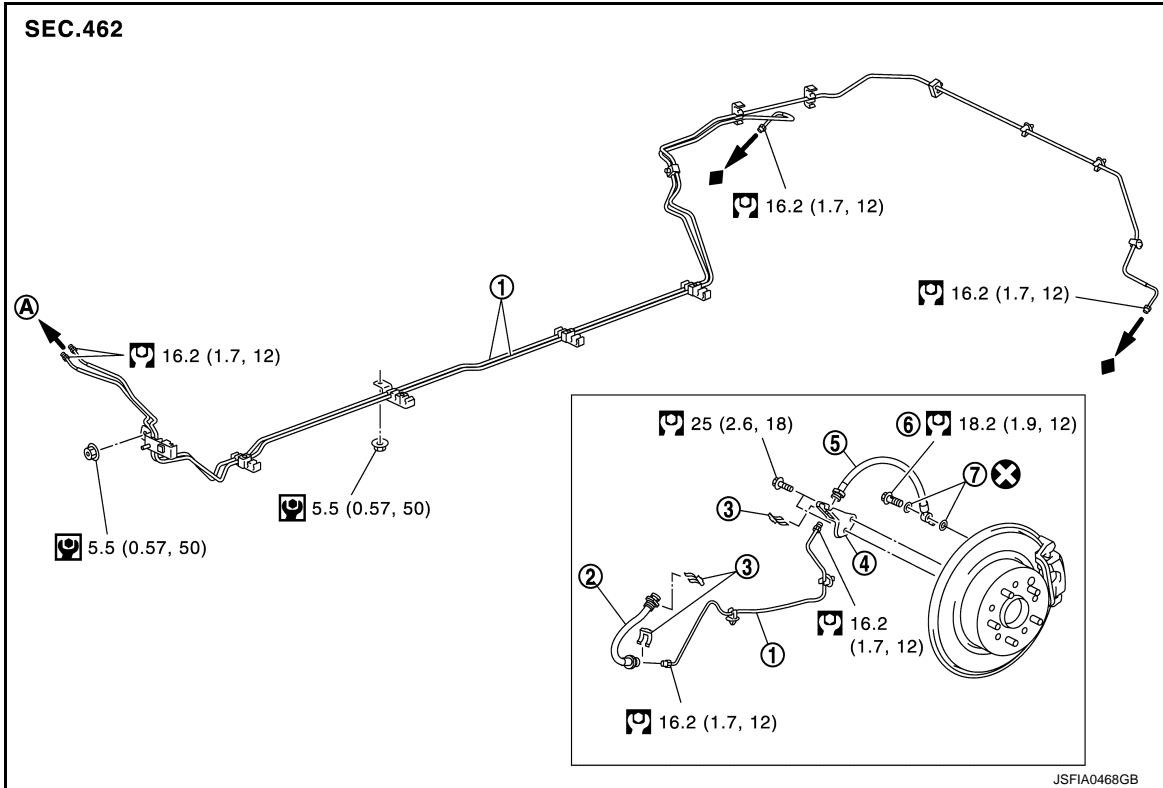

- |                       |                 |               |
|-----------------------|-----------------|---------------|
| 1. Brake tube         | 2. Brake hose A | 3. Lock plate |
| 4. Brake hose bracket | 5. Brake hose B | 6. Union bolt |
| 7. Copper washer      |                 |               |
| A. To connector       |                 |               |

: N-m (kg-m, ft-lb)

: N-m (kg-m, in-lb)

: Always replace after every disassembly.

: Indicates that the part is connected at points with same symbol in actual vehicle.

## REAR : Hydraulic Piping

INFOID:000000009752293

2WD

# BRAKE PIPING

## < REMOVAL AND INSTALLATION >

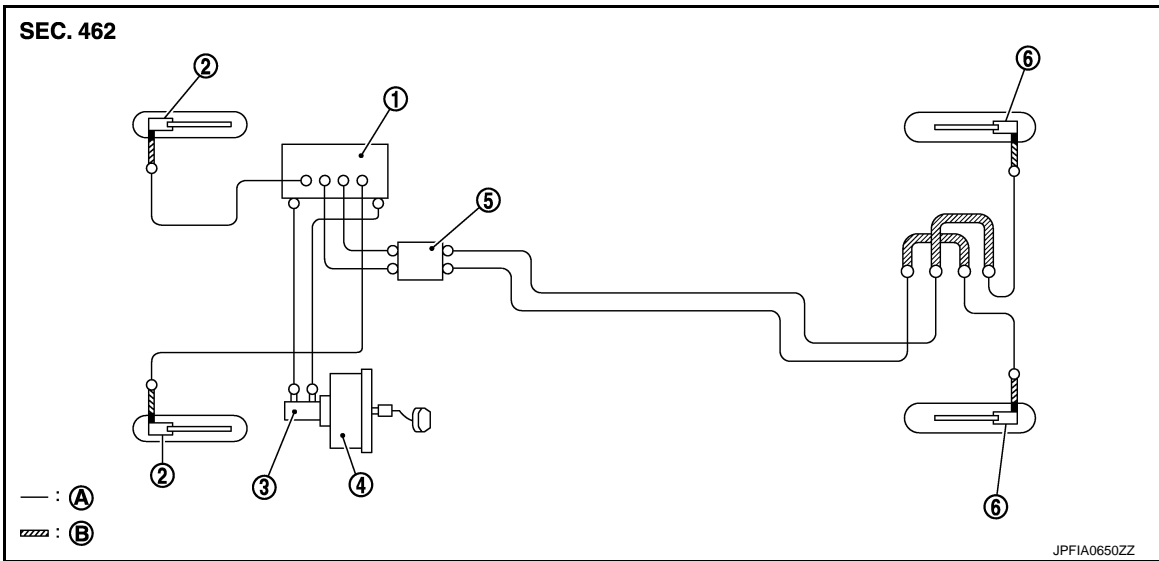

- |  |                     |                             |
|--|---------------------|-----------------------------|
| 1. ABS actuator and electric unit (control unit) | 2. Front disc brake | 3. Master cylinder assembly |
| 4. Brake booster                                 | 5. Connector        | 6. Rear disc brake          |
| A. Brake tube                                    | B. Brake hose       |                             |

- : Flare nut  
 ■ : Union bolt

AWD

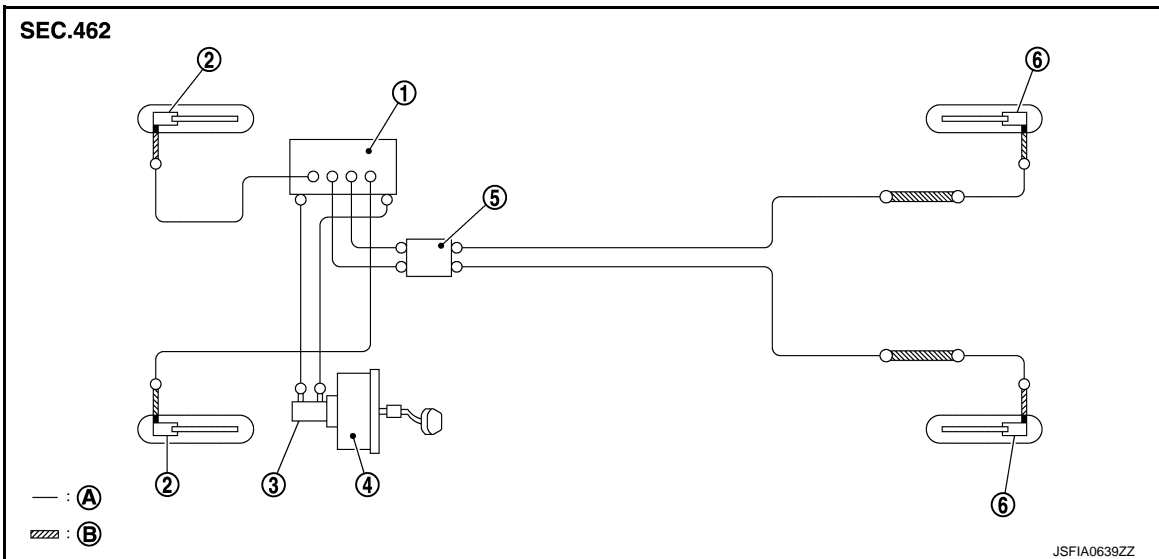

- |  |                     |                             |
|--|---------------------|-----------------------------|
| 1. ABS actuator and electric unit (control unit) | 2. Front disc brake | 3. Master cylinder assembly |
| 4. Brake booster                                 | 5. Connector        | 6. Rear disc brake          |
| A. Brake tube                                    | B. Brake hose       |                             |

- : Flare nut  
 ■ : Union bolt

## REAR : Removal and Installation

INFOID:000000009752294

### REMOVAL

# BRAKE PIPING

## < REMOVAL AND INSTALLATION >

2WD

### CAUTION:

- Never spill or splash brake fluid on painted surfaces. Brake fluid may seriously damage paint. Wipe it off immediately and wash with water if it gets on a painted surface. For brake component parts, never wash them with water.
- Never depress the brake pedal while removing the brake hose or brake tube. If this is not complied with, brake fluid may splash.

1. Remove tires with power tool.
2. Drain brake fluid. Refer to [BR-10, "Draining"](#).
3. Loosen the flare nut (1) with a flare nut wrench (A) and separate the brake tube (2) from the brake hose A (3).

### CAUTION:

- Never scratch the flare nut and the brake tube.
- Never bend sharply, twist or strongly pull out the brake hoses and tubes.
- Cover open end of brake tubes and hoses when disconnecting to prevent entrance of dirt.

4. Remove the lock plate (4) and remove the brake hose A.

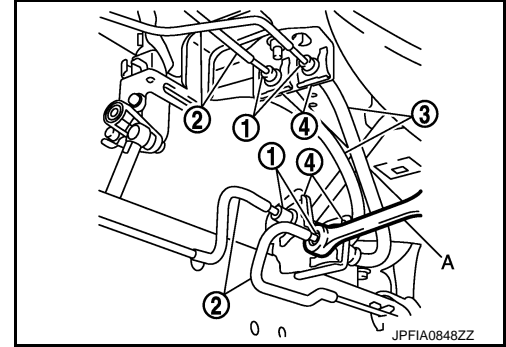

5. Loosen the flare nut (1) with a flare nut wrench (A) and separate the brake tube (2) from the hose B (3).

### CAUTION:

- Never scratch the flare nut and the brake tube.
- Never bend sharply, twist or strongly pull out the brake hoses and tubes.
- Cover open end of brake tubes and hoses when disconnecting to prevent entrance of dirt.

6. Remove the lock plate (4) from brake hose bracket (5).

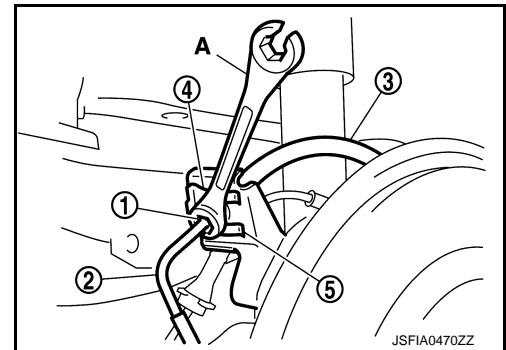

7. Remove the union bolt (1) and copper washers (2), and remove the brake hose B (3) from the brake caliper assembly.

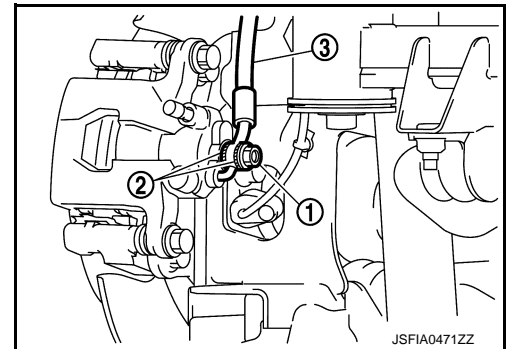

AWD

### CAUTION:

- Never spill or splash brake fluid on painted surfaces. Brake fluid may seriously damage paint. Wipe it off immediately and wash with water if it gets on a painted surface. For brake component parts, never wash them with water.
- Never depress the brake pedal while removing the brake hose or brake tube. If this is not complied with, brake fluid may splash.

1. Remove tires with power tool.
2. Drain brake fluid. Refer to [BR-10, "Draining"](#).

# BRAKE PIPING

## < REMOVAL AND INSTALLATION >

- Loosen the flare nut (1) with a flare nut wrench (A) and separate the brake tube (2) from the hose A (3).

**CAUTION:**

- Never scratch the flare nut and the brake tube.
- Never bend sharply, twist or strongly pull out the brake hoses and tubes.
- Cover open end of brake tubes and hoses when disconnecting to prevent entrance of dirt.

- Remove the lock plate (4) and remove the brake hose A.

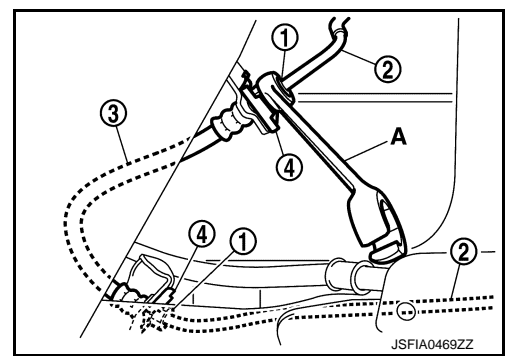

- Loosen the flare nut (1) with a flare nut wrench (A) and separate the brake tube (2) from the hose B (3).

**CAUTION:**

- Never scratch the flare nut and the brake tube.
- Never bend sharply, twist or strongly pull out the brake hoses and tubes.
- Cover open end of brake tubes and hoses when disconnecting to prevent entrance of dirt.

- Remove the lock plate (4) from brake hose bracket (5).

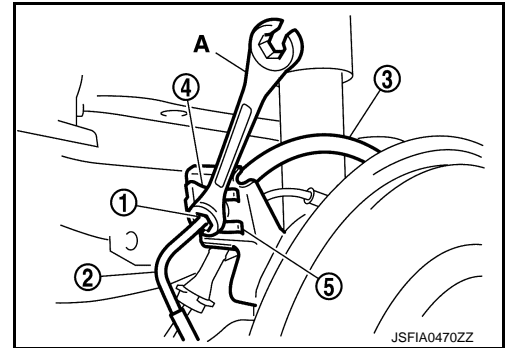

- Remove the union bolt (1) and copper washers (2), and remove the brake hose B (3) from the brake caliper assembly.

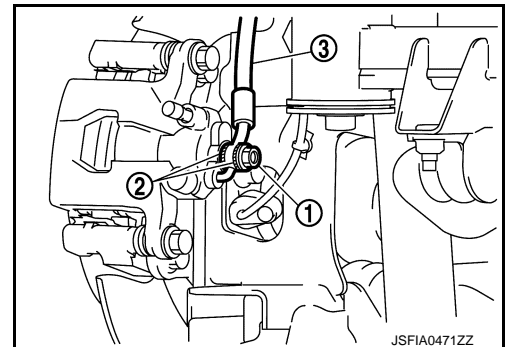

## INSTALLATION

2WD

**CAUTION:**

- Never spill or splash brake fluid on painted surfaces. Brake fluid may seriously damage paint. Wipe it off immediately and wash with water if it gets on a painted surface. For brake component parts, never wash them with water.
- Never depress the brake pedal while removing the brake hose or brake tube. If this is not complied with, brake fluid may splash.

- Assemble the union bolt (1) and the copper washer (2) to the brake hose B (3).

**CAUTION:**

**Never reuse the copper washer.**

- Align the brake hose B L-pin (A) with the brake caliper assembly hole (B), and tighten the union bolt (1) to the specified torque.

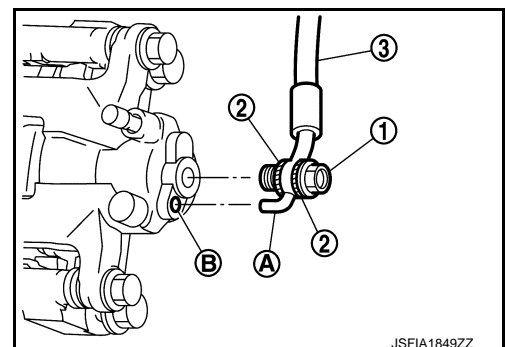

A  
B  
C  
D  
E  
BR  
G  
H  
I  
J  
K  
L  
M  
N  
O  
P

# BRAKE PIPING

## < REMOVAL AND INSTALLATION >

3. Install the brake tube (2) to the brake hose B (1), temporarily tighten the flare nut (3) by hand until it does not rotate further, and fix the brake hose B to the brake hose bracket (5) with the lock plate (4).

**CAUTION:**

**Check that all brake hoses and brake tubes are not twisted and bent.**

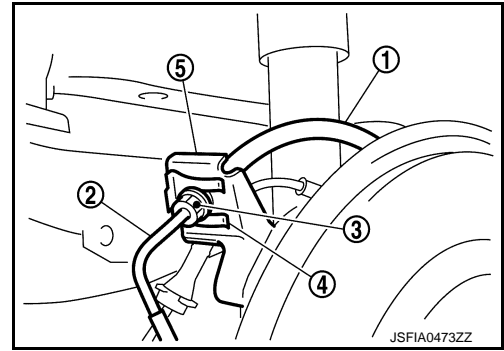

4. Tighten the flare nut to the specified torque with a crowfoot (A) and torque wrench (B).

**CAUTION:**

**Never scratch the flare nut and the brake tube.**

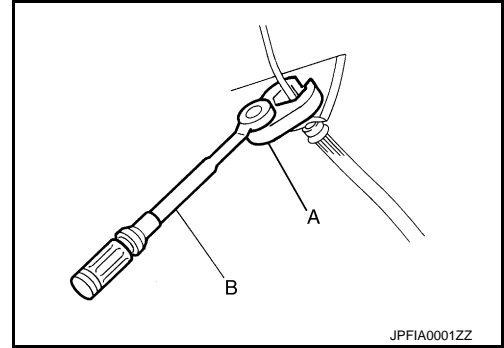

5. Install the brake tube (2) to the brake hose A (1), temporarily tighten the flare nut (3) by hand until it does not rotate further, and fix the brake hose with the lock plate (4).

**CAUTION:**

**Check that all brake hoses and brake tubes are not twisted and bent.**

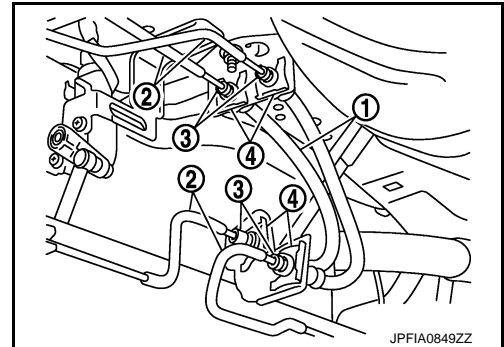

6. Tighten the flare nut to the specified torque with a crowfoot (A) and torque wrench (B).

**CAUTION:**

**Never scratch the flare nut and the brake tube.**

7. Refill with new brake fluid and perform the air bleeding. Refer to [BR-11, "Bleeding Brake System"](#).

**CAUTION:**

**Never reuse drained brake fluid.**

8. Install tires. Refer to [WT-46, "Removal and Installation"](#).
9. Perform inspection after installation. Refer to [BR-32, "REAR : Inspection"](#).

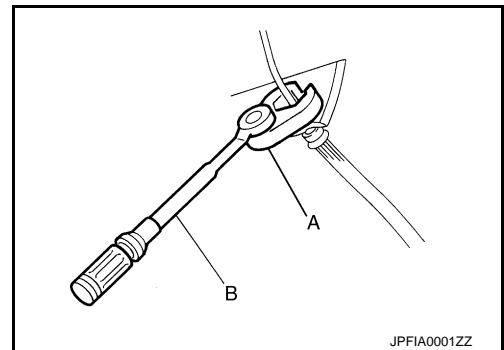

AWD

**CAUTION:**

- Never spill or splash brake fluid on painted surfaces. Brake fluid may seriously damage paint. Wipe it off immediately and wash with water if it gets on a painted surface. For brake component parts, never wash them with water.
- Never depress the brake pedal while removing the brake hose or brake tube. If this is not complied with, brake fluid may splash.

# BRAKE PIPING

## < REMOVAL AND INSTALLATION >

1. Assemble the union bolt (1) and the copper washer (2) to the brake hose B (3).

**CAUTION:**

**Never reuse the copper washer.**

2. Align the brake hose B L-pin (A) with the brake caliper assembly hole (B), and tighten the union bolt (1) to the specified torque.

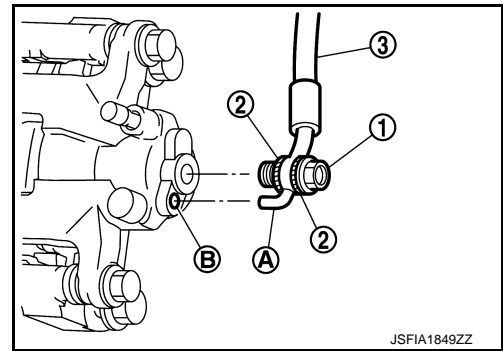

3. Install the brake tube (2) to the brake hose B (1), temporarily tighten the flare nut (3) by hand until it does not rotate further, and fix the brake hose B to the brake hose bracket (5) with the lock plate (4).

**CAUTION:**

**Check that all brake hoses and brake tubes are not twisted and bent.**

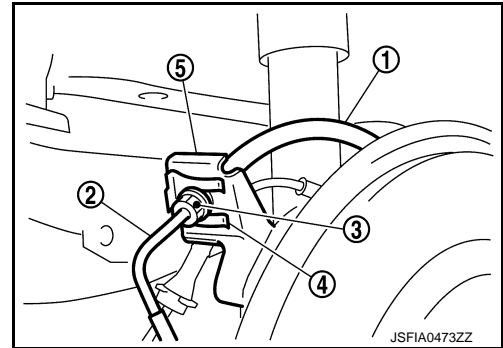

4. Tighten the flare nut to the specified torque with a crowfoot (A) and torque wrench (B).

**CAUTION:**

**Never scratch the flare nut and the brake tube.**

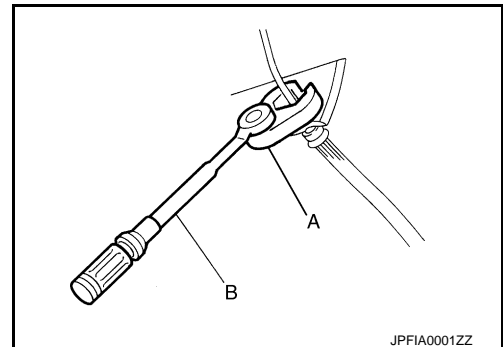

5. Install the brake tube (2) to the brake hose A (3), temporarily tighten the flare nut (1) by hand until it does not rotate further, and fix the brake hose A to the bracket with the lock plate (4).

**CAUTION:**

**Check that all brake hoses and brake tubes are not twisted and bent.**

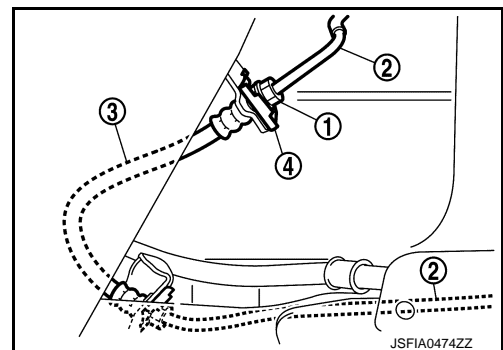

A  
B  
C  
D  
E  
BR  
G  
H  
I  
J  
K  
L  
M  
N  
O  
P

## BRAKE PIPING

### < REMOVAL AND INSTALLATION >

6. Tighten the flare nut to the specified torque with a crowfoot (A) and torque wrench (B).

**CAUTION:**

**Never scratch the flare nut and the brake tube.**

7. Refill with new brake fluid and perform the air bleeding. Refer to [BR-11, "Bleeding Brake System"](#).

**CAUTION:**

**Never reuse drained brake fluid.**

8. Install tires. Refer to [WT-46, "Removal and Installation"](#).
9. Perform inspection after installation. Refer to [BR-32, "REAR : Inspection"](#).

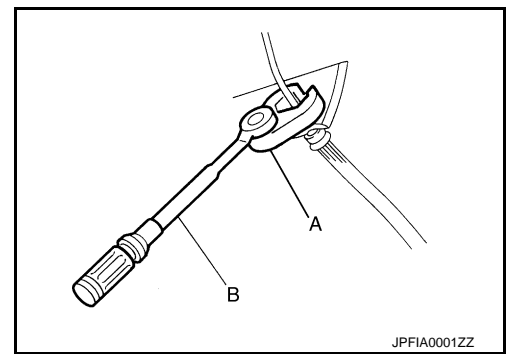

### REAR : Inspection

INFOID:000000009752295

### INSPECTION AFTER INSTALLATION

1. Check the brake hoses and tubes for the following: no scratches; no twist and deformation; no looseness at connections.
2. Depress the brake pedal with a force of 785 N (80kg, 176 lb) and hold down the pedal for approximately 5 seconds with the engine running. Check for any fluid leakage.

**CAUTION:**

**Retighten the applicable connection to the specified torque and repair any abnormal (damaged, worn or deformed) part if any brake fluid leakage is present.**



# BRAKE MASTER CYLINDER

< REMOVAL AND INSTALLATION >

## BRAKE MASTER CYLINDER

Exploded View

INFOID:000000009752296

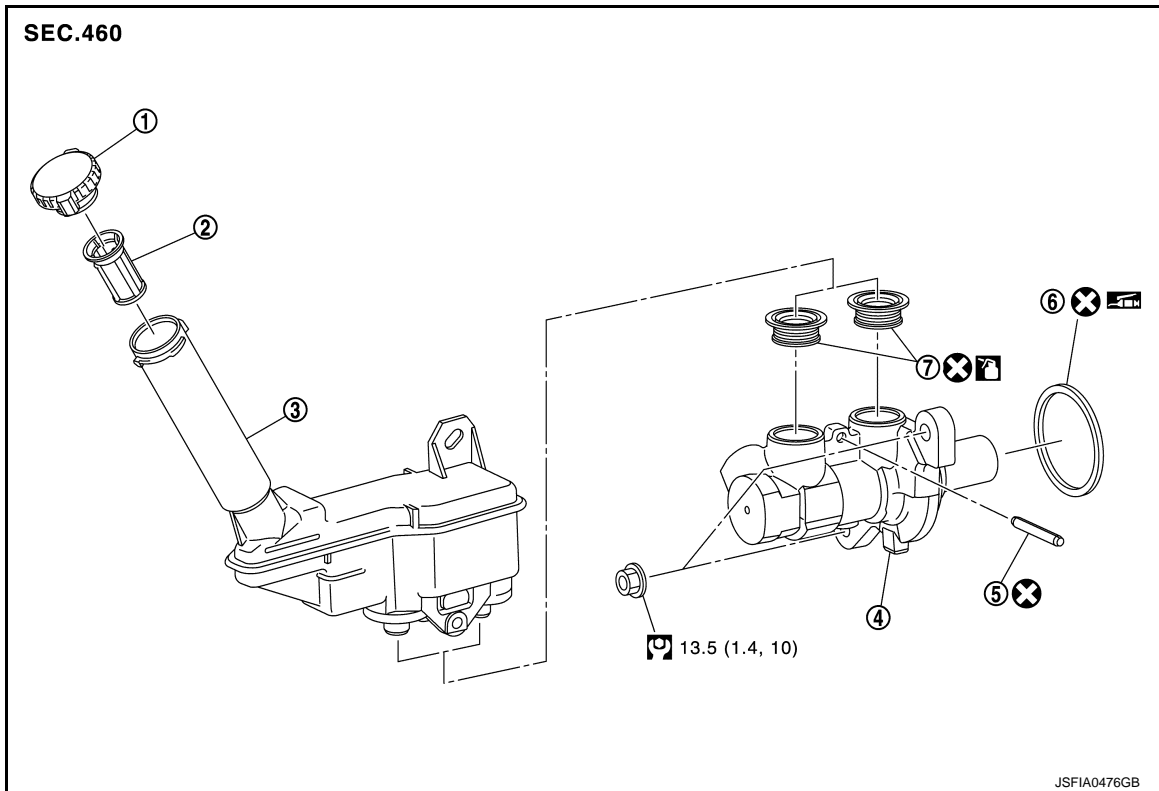

- |                  |                 |                   |
|------------------|-----------------|-------------------|
| 1. Reservoir cap | 2. Oil strainer | 3. Reservoir tank |
| 4. Cylinder body | 5. Pin          | 6. O-ring         |
| 7. Grommet       |                 |                   |

: Apply polyglycol ether based lubricant.

: Apply brake fluid.

: N·m (kg·m, ft·lb)

: Always replace after every disassembly.

## Removal and Installation

INFOID:000000009752297

### REMOVAL

#### CAUTION:

- Never spill or splash brake fluid on painted surfaces. Brake fluid may seriously damage paint. Wipe it off immediately and wash with water if it gets on a painted surface. For brake component parts, never wash them with water.
- Never depress the brake pedal while removing the brake tube. If this is not complied with, brake fluid may splash.

1. Perform inspection before removal. Refer to [BR-36. "Inspection"](#).
2. Depress the brake pedal several times to release the vacuum pressure from the brake booster.
3. Drain brake fluid. Refer to [BR-10. "Draining"](#).
4. Disconnect the brake fluid level switch harness connector.
5. Remove air duct and air cleaner case. Refer to [EM-25. "Removal and Installation"](#).

# BRAKE MASTER CYLINDER

## < REMOVAL AND INSTALLATION >

6. Separate the brake tube from master cylinder assembly with a flare nut wrench (A).

**CAUTION:**

**Never scratch the flare nut and the brake tube.**

7. Remove the master cylinder assembly.

**CAUTION:**

- Never deform or bend the brake tubes.
- Never depress the brake pedal after the master cylinder assembly is removed.

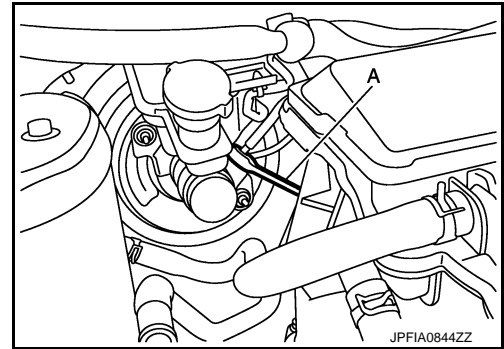

- The piston (A) of the master cylinder assembly is exposed. Never damage it when removing the master cylinder.
- The piston may drop off when pulled out strongly. Never hold the piston. Hold the cylinder body when handling the master cylinder assembly.

8. Remove the O-ring.

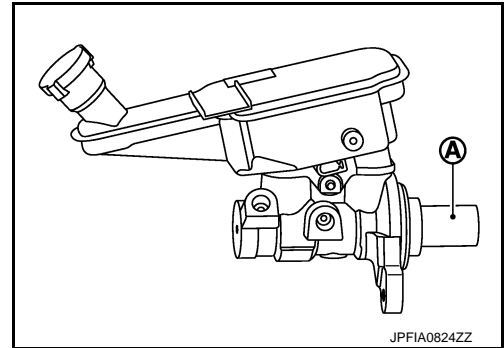

## INSTALLATION

Note the following, and install in the reverse order of removal.

- Never spill or splash brake fluid on painted surfaces. Brake fluid may seriously damage paint. Wipe it off immediately and wash with water if it gets on a painted surface. For brake component parts, never wash them with water.
- Never depress the brake pedal while removing the brake tube. If this is not complied with, brake fluid may splash.
- Never depress the brake pedal after the master cylinder assembly is removed.
- Apply polyglycol ether based lubricant to the brake booster [see (A) in the figure] when installing the master cylinder assembly to the brake booster.

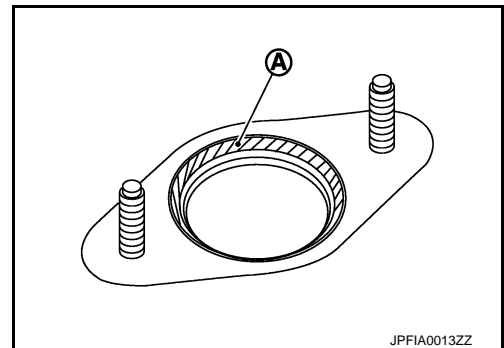

- The piston (A) of the master cylinder assembly is exposed. Never damage it when handling the master cylinder.
- Check that no dirt and dust are present on the piston before installation. Clean it with new brake fluid if necessary.
- The piston may drop off when pulled strongly. Never hold the piston. Hold the cylinder body when handling the master cylinder assembly.
- Never reuse the O-ring.
- Never deform or bend the brake tubes.

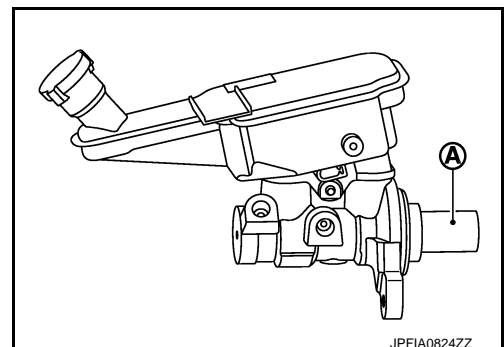

# BRAKE MASTER CYLINDER

## < REMOVAL AND INSTALLATION >

- Temporarily tighten the brake tube flare nut to the master cylinder assembly by hand. Then tighten it to the specified torque with a crowfoot and torque wrench (A). Refer to [BR-21, "FRONT : Exploded View"](#).
- Perform the air bleeding. Refer to [BR-11, "Bleeding Brake System"](#)
- Perform inspection after installation. Refer to [BR-36, "Inspection"](#).

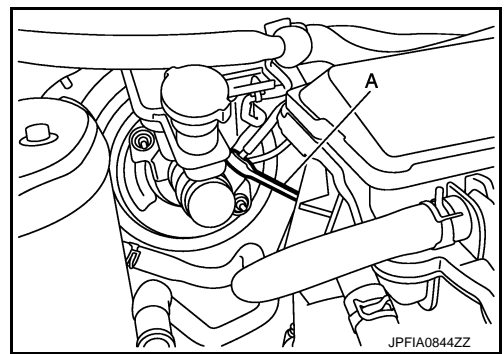

## Disassembly and Assembly

INFOID:000000009752298

### DISASSEMBLY

#### CAUTION:

- Never disassemble the cylinder body.
- Remove the reservoir tank only when necessary.

1. Fix the master cylinder assembly to a vise.

#### CAUTION:

- Always set copper plates or cloth between vise grips when fixing the cylinder body to a vise.
- Never overtighten the vise.

2. Remove the reservoir tank mounting pin with a pin punch (A) [4 mm (0.157 in)].
3. Remove the reservoir tank and grommet from the cylinder body.

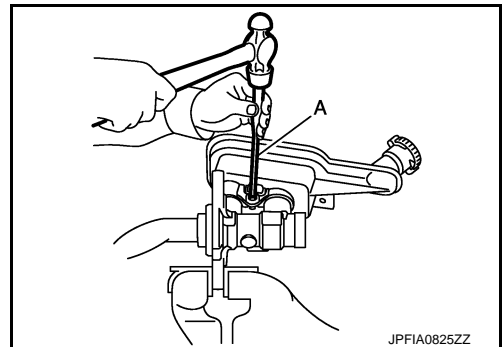

### ASSEMBLY

#### CAUTION:

- Never use mineral oils such as kerosene or gasoline and rubber grease during the cleaning and assembly process.
- Never allow foreign matter (e.g. dust) and oils other than brake fluid to enter the reservoir tank.
- Never drop the when installing. The parts must not be reused if they are dropped.

1. Apply new brake fluid to the grommet and install it to the cylinder body.

#### CAUTION:

Never reuse the grommets.

2. Install the reservoir tank to the cylinder body.
3. Fix the cylinder body to a vise.

#### CAUTION:

- Place the reservoir tank with the chamfered pin hole (←) facing up.
- Always set copper plates or cloth between vise grips when fixing the cylinder body to a vise.
- Never overtighten the vise.

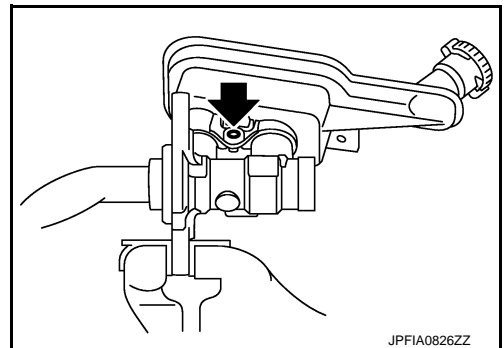

# BRAKE MASTER CYLINDER

## < REMOVAL AND INSTALLATION >

---

4. Tilt the reservoir tank so that a mounting pin can be inserted. Insert a mounting pin. Return the reservoir tank to the horizontal position. Insert another mounting pin into the pin hole on the opposite side in the same manner after the mounting pin passes through the cylinder body pin hole.

**CAUTION:**

**Never reuse the mounting pin.**

## Inspection

INFOID:000000009752299

### INSPECTION BEFORE REMOVAL

Check the brake fluid level switch. Refer to [BRC-103, "Component Inspection"](#).

### INSPECTION AFTER INSTALLATION

Check the following items and replace if necessary.

- Check the master cylinder for deformation, twist, contact with other parts or looseness of connection.
- Check for fluid leakage from connection. Refer to [BR-24, "FRONT : Inspection"](#).

**CAUTION:**

**If the fluid leakage is present, retighten to the specified torque. Replace if necessary.**

# BRAKE BOOSTER

< REMOVAL AND INSTALLATION >

## BRAKE BOOSTER

### Exploded View

INFOID:000000009752300

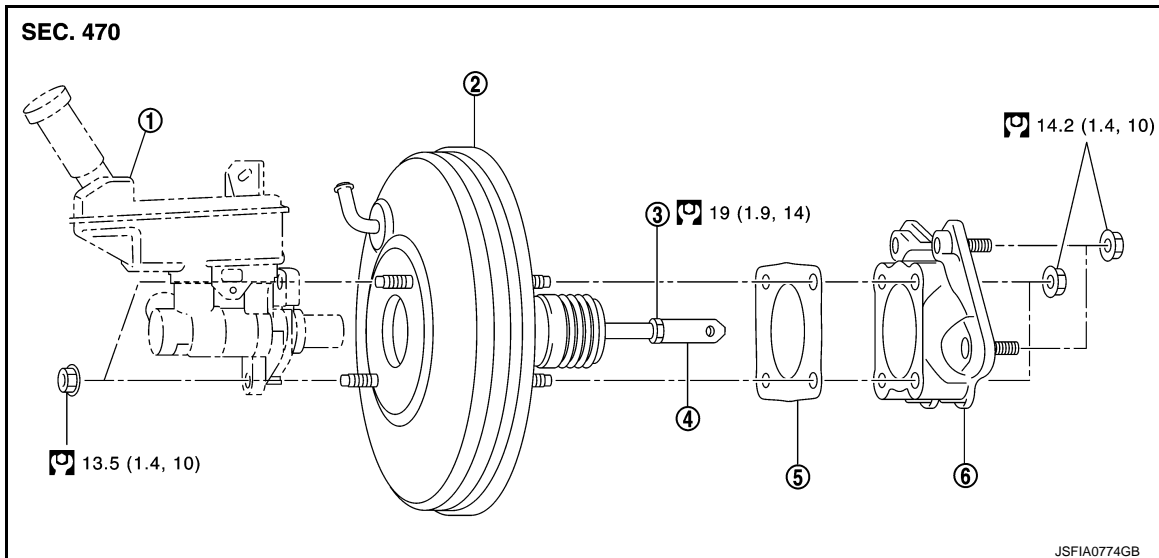

- |                             |                  |             |
|-----------------------------|------------------|-------------|
| 1. Master cylinder assembly | 2. Brake booster | 3. Lock nut |
| 4. Clevis                   | 5. Gasket        | 6. Spacer   |

: N·m (kg-m, ft-lb)

### Removal and installation

INFOID:000000009752301

#### REMOVAL

1. Perform inspection before removal. Refer to [BR-38, "Inspection and Adjustment"](#).
2. Remove cowl top and cowl top extension. Refer to [EXT-26, "Removal and Installation"](#).
3. Remove air duct and air cleaner case. Refer to [EM-25, "Removal and Installation"](#).
4. Remove brake master cylinder assembly. Refer to [BR-33, "Removal and Installation"](#).
5. Remove vacuum hose from brake booster. Refer to [BR-40, "Removal and Installation"](#).
6. Remove snap pin (1) and clevis pin (2). Refer to [BR-18, "Exploded View"](#).
7. Remove nuts on brake booster and brake pedal assembly.

#### CAUTION:

**Hold the brake booster so as to avoid dropping out.**

8. Remove brake booster and spacer.

#### CAUTION:

**Never deform or bend the brake tubes.**

#### NOTE:

If removing brake booster is difficult, remove clevis from brake booster.

9. Remove spacer from brake booster.

10. Perform inspection after removal. Refer to [BR-38, "Inspection and Adjustment"](#).

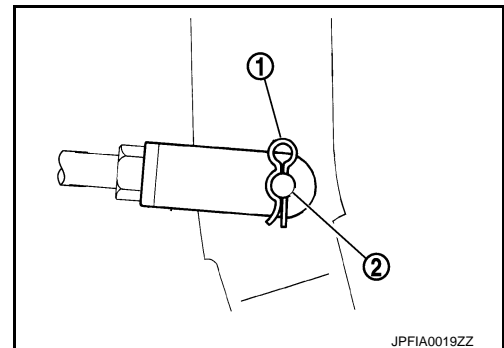

#### INSTALLATION

#### CAUTION:

**Never spill or splash brake fluid on painted surfaces. Brake fluid may seriously damage paint. Wipe it off immediately and wash with water if it gets on a painted surface.**

Note the following, and install in the reverse order of removal.

- Be careful not to damage brake booster stud bolt threads. If brake booster is tilted during installation, the dash panel may damage the threads.

# BRAKE BOOSTER

## < REMOVAL AND INSTALLATION >

- Never deform or bend the brake tubes when installing the brake booster.
- Always use a gasket between the brake booster and the spacer.
- Replace the clevis pin if it is damaged. Refer to [BR-19. "Inspection and Adjustment"](#).
- Perform the air bleeding. Refer to [BR-11. "Bleeding Brake System"](#).
- Check each item of brake pedal. Adjust it if the measurement value is not the standard. Refer to [BR-7. "Inspection and Adjustment"](#).

## Inspection and Adjustment

INFOID:000000009752302

### INSPECTION BEFORE REMOVAL

Air Tight

#### **CAUTION:**

**Check the air tight condition when the master cylinder and the brake booster is installed.**

1. Check the air tight use a handy vacuum pump.

**At vacuum of  $-66.7$  kPa ( $-500$  mmHg,  $-19.69$  inHg) : Vacuum should decrease within  $3.3$  kPa ( $24.8$  mmHg,  $0.98$  inHg) for 15 seconds.**

2. If the air tight condition cannot be maintained, perform the following operation.
  - a. Check the no dirt and dust are present on the brake booster and brake master cylinder mating faces. Clean it if necessary.
  - b. Check the O-ring on the master cylinder. If anything is found, replace the O-ring. Refer to [BR-33. "Removal and Installation"](#).
  - c. Check the air tight condition again. If the condition still cannot be maintained, replace the brake booster.

### INSPECTION AFTER REMOVAL

Input Rod Length Inspection

1. Loosen the lock nut (1) and adjust the input rod (2) to the specified length (A).

**A : Refer to [BR-58. "Brake Booster"](#).**

2. Tighten the lock nut to the specified torque.

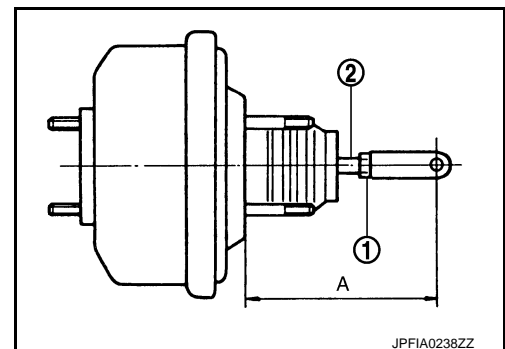

### INSPECTION AFTER INSTALLATION

Operation

Depress the brake pedal several times at 5-second intervals with the engine stopped. Start the engine with the brake pedal fully depressed. Check that the clearance between brake pedal and dash lower panel decreases.

#### **NOTE:**

A slight impact with a small click may be felt on the pedal when the brake pedal is fully depressed. This is a normal phenomenon due to the brake system operation.

Air Tight

1. Run the engine at idle for 1 minute to apply vacuum to the brake booster, and stop the engine.
2. Depress the brake pedal several times at 5-second intervals until the accumulated vacuum is released to atmospheric pressure. Check that the clearance between brake pedal and dash lower panel gradually increases each time the brake pedal is depressed when performing this operation.
3. Depress the brake pedal with the engine running. Then stop the engine while holding down the brake pedal. Check that the brake pedal stroke does not change after holding down the brake pedal for 30 seconds or more.

### ADJUSTMENT AFTER INSTALLATION

# BRAKE BOOSTER

## < REMOVAL AND INSTALLATION >

Perform the brake pedal adjustment after installing the brake pedal assembly. Refer to [BR-7. "Inspection and Adjustment"](#).

- A
- B
- C
- D
- E
- BR**
- G
- H
- I
- J
- K
- L
- M
- N
- O
- P

# VACUUM LINES

< REMOVAL AND INSTALLATION >

## VACUUM LINES

### Exploded View

INFOID:000000009752303

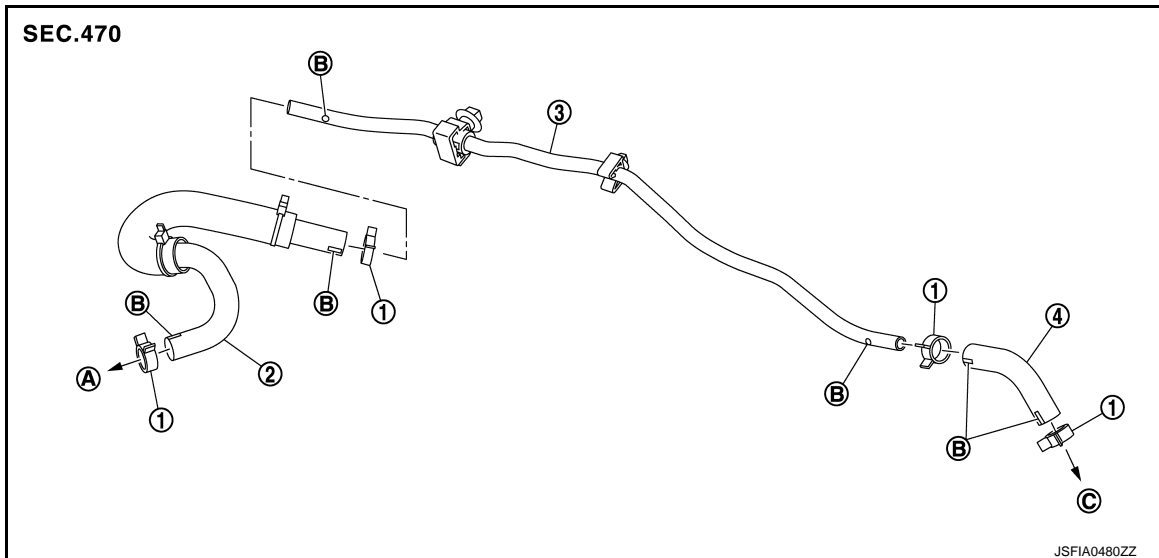

- |                   |                  |                     |
|-------------------|------------------|---------------------|
| 1. Clamp          | 2. Vacuum hose A | 3. Vacuum piping    |
| 4. Vacuum hose B  |                  |                     |
| A. To engine side | B. Paint mark    | C. To brake booster |

### Removal and Installation

INFOID:000000009752304

#### REMOVAL

1. Remove air duct and air cleaner case. Refer to [EM-25, "Removal and Installation"](#).
2. Remove the vacuum hose and vacuum piping.
3. Perform inspection after removal. Refer to [BR-40, "Inspection"](#).

#### INSTALLATION

Note the following, install the vacuum hose.

- When installing vacuum hose, insert it until its tip reaches the back-end of length (A) or further as shown in the figure.

#### CAUTION:

**Never use lubricating oil during assembly.**

**A : 24 mm (0.95 in) or more**

- Face the paint mark of vacuum hose A (engine side) upward to assemble.
- Face the other paint marks to vehicle front side to assemble.
- For clamp mounting direction (the orientation of pawl), refer to [BR-40, "Exploded View"](#).

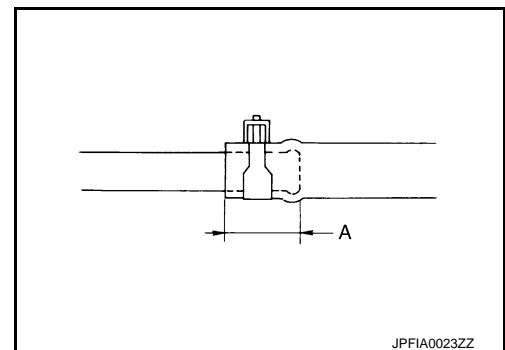

### Inspection

INFOID:000000009752305

#### INSPECTION AFTER REMOVAL

Appearance

Check for correct assembly, damage and deterioration.

Check Valve Airtightness



## VACUUM LINES

### < REMOVAL AND INSTALLATION >

- Use a handy vacuum pump (A) to check.

**When connected to the booster side (B):**

**Vacuum should decrease within 1.3 kPa (9.8 mmHg, 0.38 inHg) for 15 seconds under a vacuum of -66.7 kPa (-500 mmHg, -19.70 inHg).**

**When connected to the engine side (C):**

**Vacuum should not exist.**

- Replace vacuum hose if vacuum hose is malfunctioning.

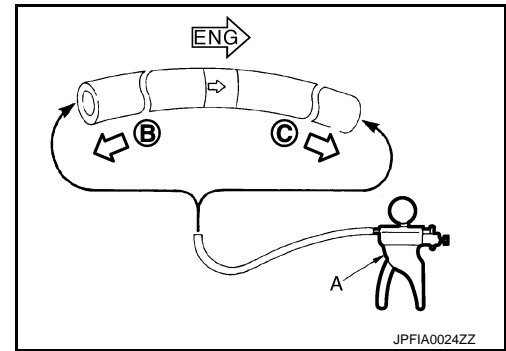

A  
B  
C  
D  
E  
BR  
G  
H  
I  
J  
K  
L  
M  
N  
O  
P

# FRONT DISC BRAKE

< REMOVAL AND INSTALLATION >

## FRONT DISC BRAKE

### BRAKE PAD

#### BRAKE PAD : Exploded View

INFOID:000000009752306

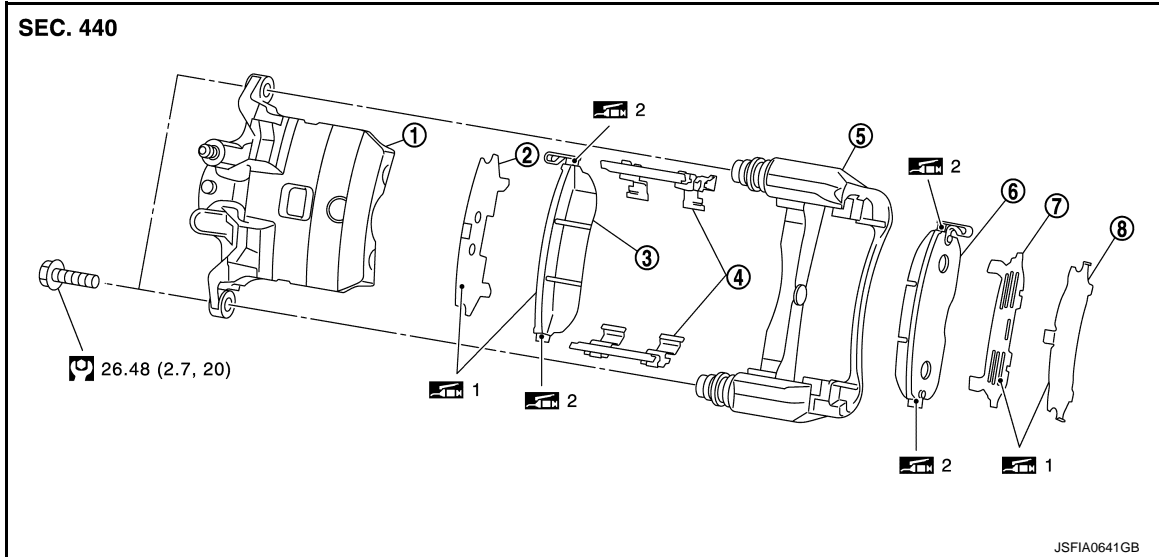

- |                  |                     |                                     |
|------------------|---------------------|-------------------------------------|
| 1. Cylinder body | 2. Inner shim       | 3. Inner pad (with pad wear sensor) |
| 4. Pad retainer  | 5. Torque member    | 6. Outer pad                        |
| 7. Outer shim    | 8. Outer shim cover |                                     |

1: Apply MOLYKOTE® AS880N or silicone-based grease.

2: Apply MOLYKOTE® 7439 or equivalent.

: N·m (kg·m, ft·lb)

Molykote is a registered trademark of Dow Corning Corporation.

#### BRAKE PAD : Removal and Installation

INFOID:000000009752307

##### REMOVAL

##### **WARNING:**

Since dust covering the front brake has an affect on human body, the dust must be removed with a dust collector. Never splatter the dust with an air blow gun.

##### **CAUTION:**

- Never depress the brake pedal while removing the brake pads because the piston may pop out.
- If the brake fluid or grease adheres to the disc rotor, quickly wipe it off.

1. Remove tires with power tool.
2. Remove lower sliding pin bolt.

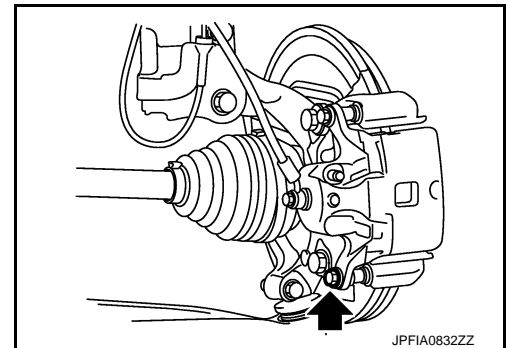

# FRONT DISC BRAKE

## < REMOVAL AND INSTALLATION >

3. Suspend the cylinder body with suitable wire so that the brake hose will not stretch.

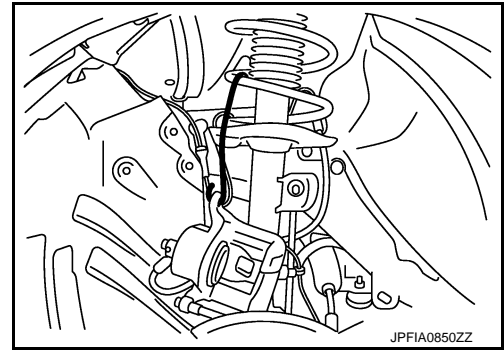

4. Remove the brake pads, shims, shim covers and pad retainers from the torque member.

### CAUTION:

- Never deform the pad retainer (2) when removing the pad retainer from the torque member (1).
- Never damage the piston boot.
- Never drop the brake pads, shims, and the shim covers.
- Remember each position of the removed brake pads.

5. Perform inspection after removal. Refer to [BR-44, "BRAKE PAD : Inspection"](#).

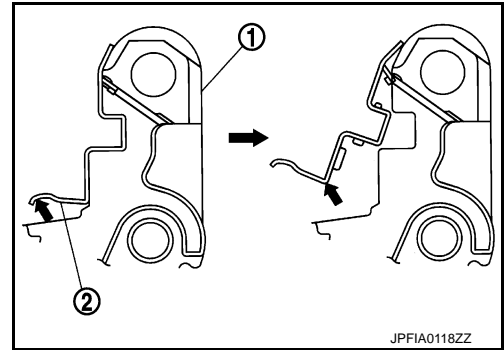

## INSTALLATION

### WARNING:

Since dust covering the front brake has an affect on human body, the dust must be removed with a dust collector. Never splatter the dust with an air blow gun.

### CAUTION:

- Never depress the brake pedal while removing the brake pads or the cylinder body because the piston may pop out.
- If the brake fluid or grease adheres to the disc rotor, quickly wipe it off.

1. Install the pad retainers (1) to the torque member (2) if the pad retainers has been removed.

### CAUTION:

- Securely assemble the pad retainers so that it will not be lifted up from the torque member.
- Never deform the pad retainers.

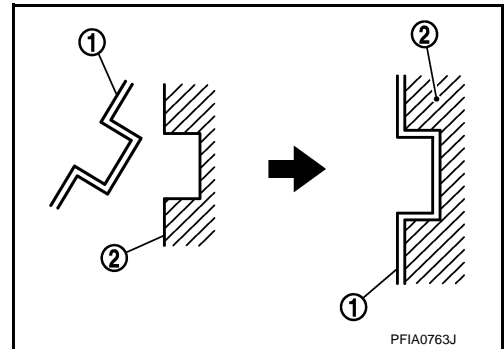

2. Apply MOLYKOTE® AS880N or silicone-based grease to the mating faces (A) between the inner pad and the inner shim, and install the inner shims to the inner pad.

### CAUTION:

**Always replace the shim together when replacing the brake pad.**

Molykote is a registered trademark of Dow Corning Corporation.

3. Apply MOLYKOTE® 7439 or equivalent to the mating faces (B) between the inner pad and the pad retainers. Molykote is a registered trademark of Dow Corning Corporation.

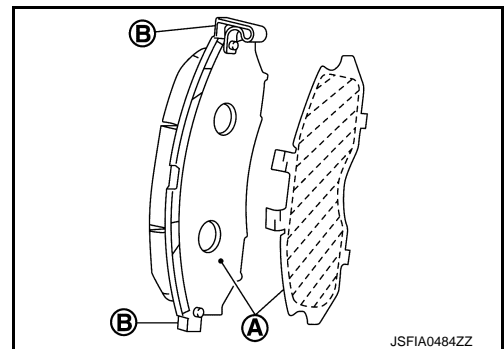

# FRONT DISC BRAKE

## < REMOVAL AND INSTALLATION >

4. Apply MOLYKOTE® AS880N or silicone-based grease to the mating faces (A) between the outer shim cover and the outer shim, and install the outer shim and outer shim cover to the outer pad.

**CAUTION:**

**Always replace the shim together with the shim cover when replacing the brake pad.**

Molykote is a registered trademark of Dow Corning Corporation.

5. Apply MOLYKOTE® 7439 or equivalent to the mating faces (B) between the outer pad and the pad retainers.
- Molykote is a registered trademark of Dow Corning Corporation.

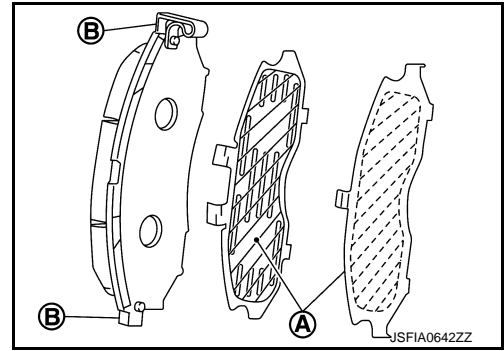

6. Install the brake pads to the torque member.

**CAUTION:**

- Both inner and outer pads have a pad return system on the pad retainer. Install pad return lever (1) securely to pad retainer (2).
- Never deform the pad retainers.

7. Install cylinder body to torque member.

**CAUTION:**

- Never damage the piston boot.
- When replacing brake pad with new one, check a brake fluid level in the reservoir tank because brake fluid returns to master cylinder reservoir tank when pressing piston in.

**NOTE:**

Use a disc brake piston tool to easily press piston.

8. Install the lower sliding pin bolt and tighten it to the specified torque.

9. Depress the brake pedal several times to check that no drag feel is present for the front disc brake. Refer to [BR-44, "BRAKE PAD : Inspection"](#).

10. Install tires. Refer to [WT-46, "Removal and Installation"](#).

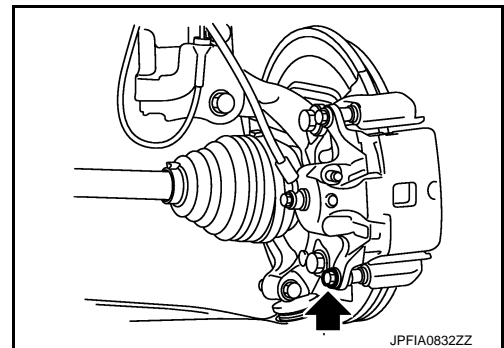
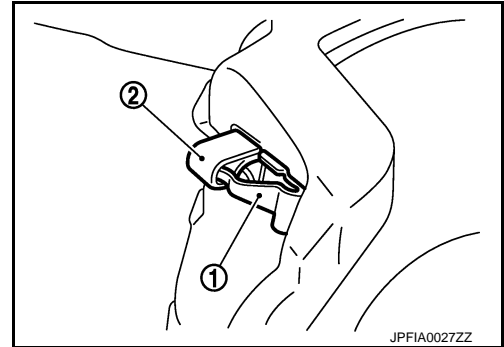

## BRAKE PAD : Inspection

INFOID:000000009752308

### INSPECTION AFTER REMOVAL

- Replace the shims and the shim covers if rust is excessively attached.
- Eliminate rust on the pad retainers and the torque member. Replace them if rust is excessively attached.

### INSPECTION AFTER INSTALLATION

1. Check a drag of front disc brake. If any drag is found, follow the procedure described below.
2. Remove brake pads. Refer to [BR-42, "BRAKE PAD : Removal and Installation"](#).
3. Press the pistons. Refer to [BR-42, "BRAKE PAD : Removal and Installation"](#).
4. Install brake pads. Refer to [BR-42, "BRAKE PAD : Removal and Installation"](#).
5. Securely depress the brake pedal several times.
6. Check a drag of front disc brake again. If any drag is found, disassemble the cylinder body and replace if necessary. Refer to [BR-47, "BRAKE CALIPER ASSEMBLY : Disassembly and Assembly"](#).
7. Burnish contact surfaces brake pads and disc rotor after refinishing or replacing brake pads, or if a soft pedal occurs at very low mileage. Refer to [BR-14, "BRAKE PAD : Inspection and Adjustment"](#).

## BRAKE CALIPER ASSEMBLY

# FRONT DISC BRAKE

< REMOVAL AND INSTALLATION >

## BRAKE CALIPER ASSEMBLY : Exploded View

INFOID:000000009752309

### REMOVAL

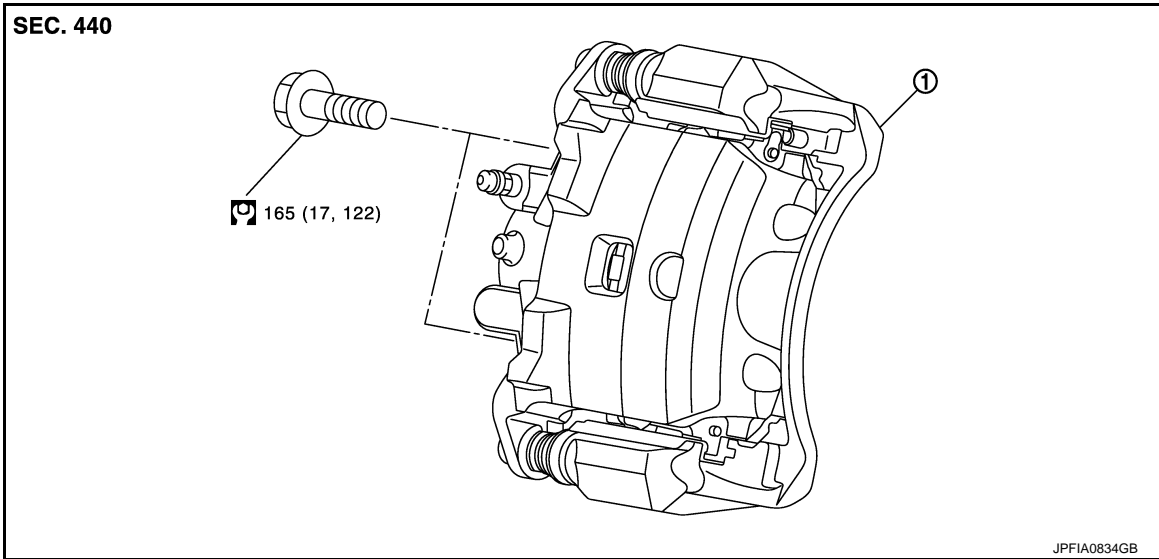

1. Brake caliper assembly

: N·m (kg-m, ft-lb)

### DISASSEMBLY

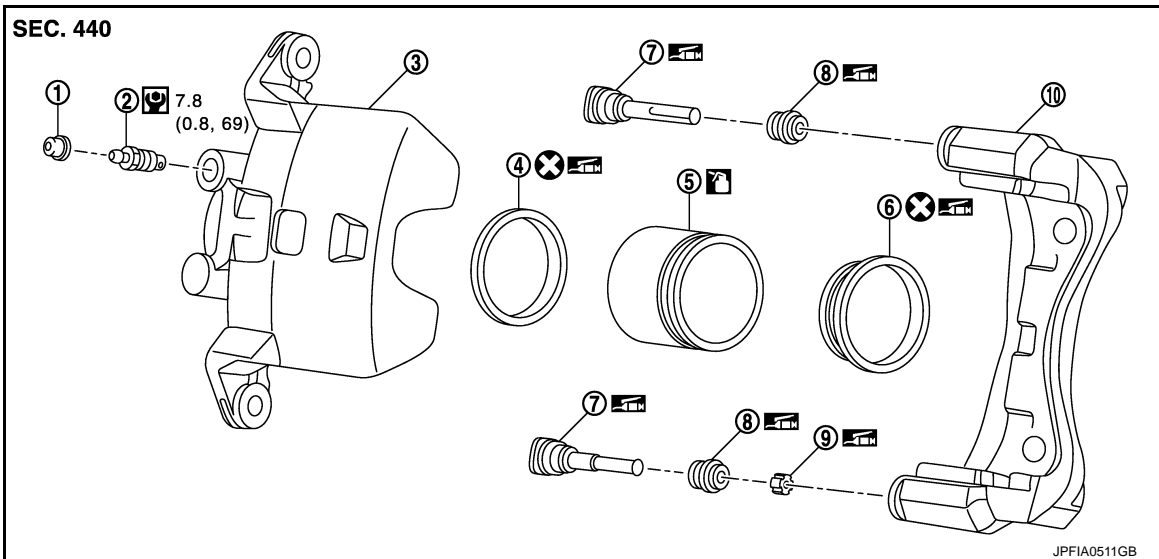

- |                   |                     |                  |
|-------------------|---------------------|------------------|
| 1. Cap            | 2. Bleeder valve    | 3. Cylinder body |
| 4. Piston seal    | 5. Piston           | 6. Piston boot   |
| 7. Sliding pin    | 8. Sliding pin boot | 9. Bushing       |
| 10. Torque member |                     |                  |

: Apply rubber grease.

: Apply brake fluid.

: N·m (kg-m, in-lb)

: Always replace after every disassembly.

# FRONT DISC BRAKE

< REMOVAL AND INSTALLATION >

## BRAKE CALIPER ASSEMBLY : Removal and Installation

INFOID:00000009752310

### REMOVAL

#### **WARNING:**

Since dust covering the front brake has an affect on human body, the dust must be removed with a dust collector. Never splatter the dust with an air blow gun.

#### **CAUTION:**

- Never spill or splash brake fluid on painted surfaces. Brake fluid may seriously damage paint. Wipe it out immediately and wash with water if it gets on a protect surface. For brake component parts, never wash them with water.
- Never depress the brake pedal while removing the brake hose. If this is not complied with, brake fluid may splash.
- Never drop removed parts.
- If the brake fluid or grease adheres to the disc rotor, quickly wipe it off.

1. Remove tires with power tool.
2. Fix the disc rotor using wheel nuts.
3. Drain brake fluid. Refer to [BR-10, "Draining"](#).
4. Separate brake hose from caliper assembly. Refer to [BR-22, "FRONT : Removal and Installation"](#).
5. Remove torque member mounting bolts, and remove brake caliper assembly.

#### **CAUTION:**

Never drop brake pad and caliper assembly.

6. When removing disc rotor. Refer to [FAX-9, "Removal and Installation"](#).

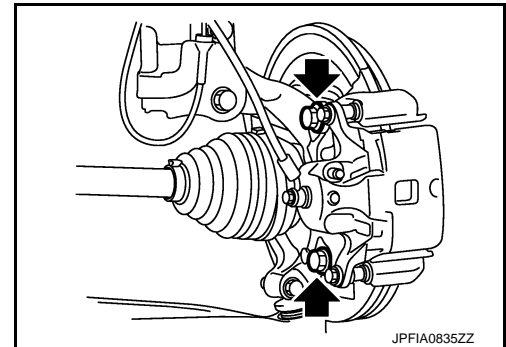

### INSTALLATION

#### **WARNING:**

Since dust covering the front brake has an affect on human body, the dust must be removed with a dust collector. Never splatter the dust with an air blow gun.

#### **CAUTION:**

- Never spill or splash brake fluid on painted surfaces. Brake fluid may seriously damage paint. Wipe it out immediately and wash with water if it gets on a protect surface. For brake component parts, never wash them with water.
- Never depress the brake pedal while removing the brake hose. If this is not complied with, brake fluid may splash.
- If the brake fluid or grease adheres to the disc rotor, quickly wipe it off.

1. Install disc rotor. Refer to [FAX-9, "Removal and Installation"](#).
2. Install the brake caliper assembly to the steering knuckle and tighten the torque member mounting bolts to the specified torque.

#### **CAUTION:**

Never spill or splash any grease and moisture on the brake caliper assembly mounting face, threads, mounting bolts and washers. Wipe out any grease and moisture.

3. Install brake hose. Refer to [BR-22, "FRONT : Removal and Installation"](#).
4. Perform the air bleeding. Refer to [BR-11, "Bleeding Brake System"](#).
5. Check a drag of front disc brake. If any drag is found, refer to [BR-49, "BRAKE CALIPER ASSEMBLY : Inspection"](#).
6. Install tires. Refer to [WT-46, "Removal and Installation"](#).
7. Perform inspection after installation. Refer to [BR-49, "BRAKE CALIPER ASSEMBLY : Inspection"](#).

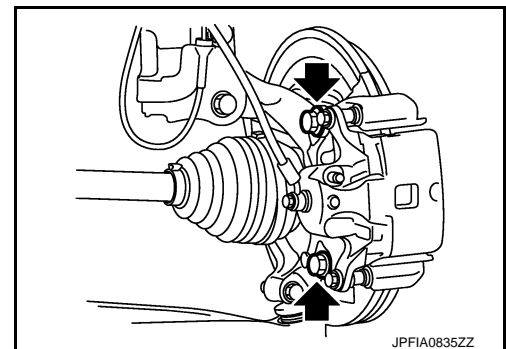

# FRONT DISC BRAKE

< REMOVAL AND INSTALLATION >

## BRAKE CALIPER ASSEMBLY : Disassembly and Assembly

INFOID:000000009752311

### DISASSEMBLY

#### NOTE:

Never remove the torque member, brake pad and pad retainers when disassembling and assembling the cylinder body.

1. Remove the sliding pin bolt, and remove the cylinder body from the torque member. Refer to [BR-42, "BRAKE PAD : Removal and Installation"](#).

#### CAUTION:

**Fix the brake pad at suitable tape so that the brake pad will not drop.**

2. Remove sliding pins and sliding pin boots from torque member.
3. Remove bushing (1) from sliding pin (2).

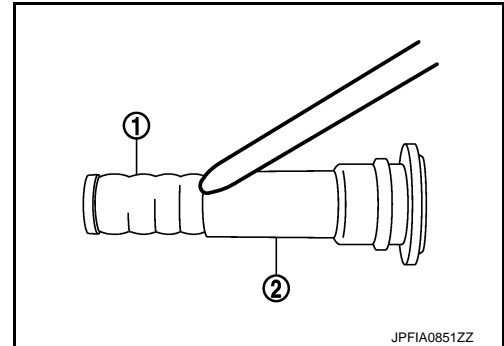

4. Place a wooden block as shown in the figure, and blow air from union bolt mounting hole to remove pistons and piston boots.

#### CAUTION:

**Never get fingers caught in the pistons.**

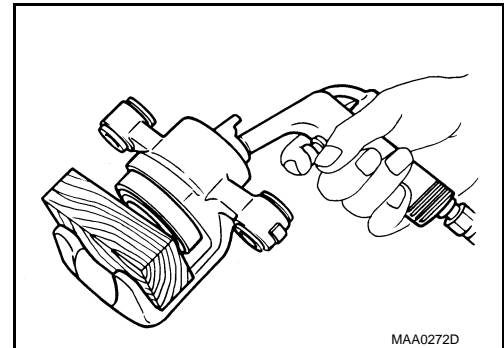

5. Remove piston seal from cylinder body using seal pick tool.

#### CAUTION:

**Be careful not to damage a cylinder inner wall.**

6. Remove bleeder valve and cap.
7. Perform inspection after disassembly. Refer to [BR-49, "BRAKE CALIPER ASSEMBLY : Inspection"](#).

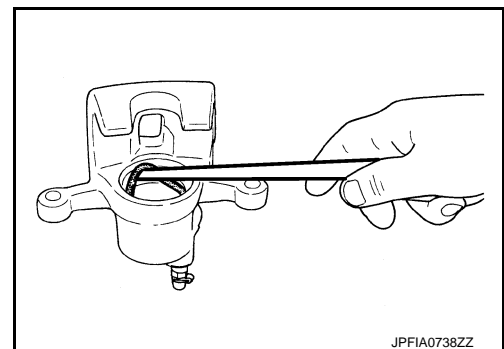

### ASSEMBLY

1. Install bleeder valve and cap.

# FRONT DISC BRAKE

## < REMOVAL AND INSTALLATION >

2. Apply rubber grease to piston seals (1), and install them to cylinder body.

**CAUTION:**

**Never reuse piston seals.**

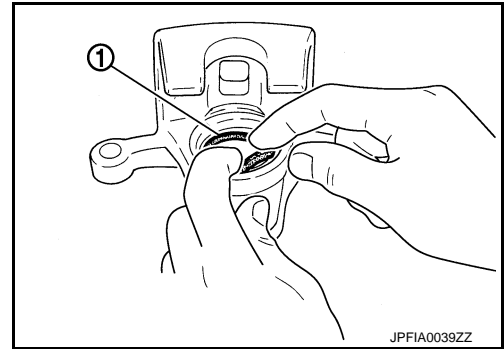

3. Apply rubber grease to piston boots (1). Cover the piston (2) end with piston boot, and then install cylinder side lip on piston boot securely into a groove on cylinder body.

**CAUTION:**

**Never reuse piston boots.**

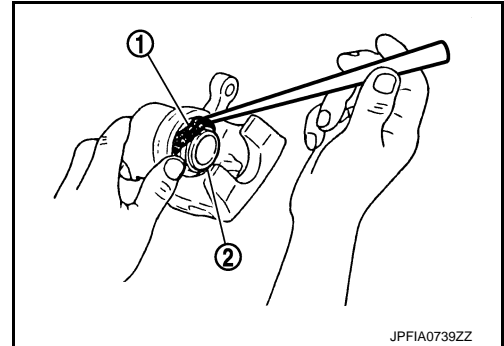

4. Apply new brake fluid to pistons (1). Push piston into cylinder body by hand and push piston boot (2) piston-side lip into the piston groove.

**CAUTION:**

**Press the pistons evenly and vary the pressing point to prevent cylinder inner wall from being rubbed.**

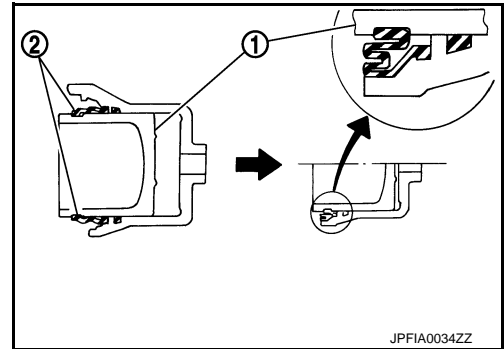

5. Apply rubber grease to mating faces (A) between sliding pin (1) and bushing (2), and install bushing to sliding pin.

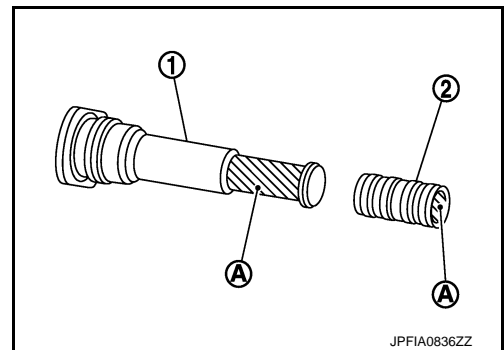



# FRONT DISC BRAKE

## < REMOVAL AND INSTALLATION >

6. Apply rubber grease to mating faces (A) between sliding pin (1) and sliding pin boot (2), and install sliding pin and sliding pin boot to sliding torque member (3).
7. Install the cylinder body to tighten cylinder body mounting bolts to the specified torque. Refer to [BR-42, "BRAKE PAD : Exploded View"](#).

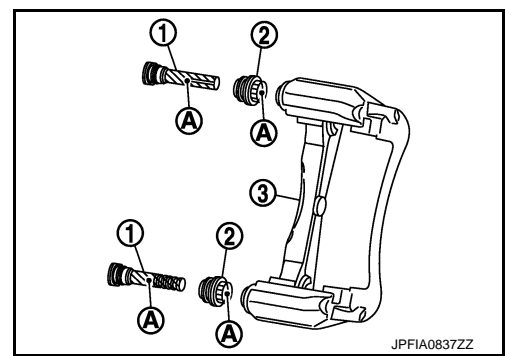

## BRAKE CALIPER ASSEMBLY : Inspection

### INSPECTION AFTER DISASSEMBLY

Check the following items and replace if necessary.

#### Cylinder Body

Check the inner wall of the cylinder for rust, wear, cracks or damage.

#### **CAUTION:**

**Always clean with new brake fluid. Never clean with mineral oil such as gasoline and light oil.**

#### Torque Member

Check the torque member for rust, wear, cracks or damage.

#### Pistons

Check the surface of the piston for rust, wear, cracks or damage.

#### **CAUTION:**

**A piston sliding surface is plated. Never polish with sandpaper.**

#### Sliding Pin, Sliding Pin Boot and Bushing

Check the sliding pins, sliding boots and bushing for rust, wear, cracks or damage.

### INSPECTION AFTER INSTALLATION

1. Check a drag of front disc brake. If any drag is found, follow the procedure described below.
2. Remove brake pads. Refer to [BR-42, "BRAKE PAD : Removal and Installation"](#).
3. Press the pistons. Refer to [BR-42, "BRAKE PAD : Removal and Installation"](#).
4. Install brake pads. Refer to [BR-42, "BRAKE PAD : Removal and Installation"](#).
5. Securely depress the brake pedal several times.
6. Check a drag of front disc brake again. If any drag is found, disassemble the cylinder body and replace if necessary. Refer to [BR-47, "BRAKE CALIPER ASSEMBLY : Disassembly and Assembly"](#).
7. Burnish contact surface between disc rotor and brake pads after refinishing or replacing disc rotor, or if a soft pedal occurs at very low mileage. Refer to [BR-14, "DISC ROTOR : Inspection and Adjustment"](#).

# REAR DISC BRAKE

< REMOVAL AND INSTALLATION >

## REAR DISC BRAKE BRAKE PAD

### BRAKE PAD : Exploded View

INFOID:000000009752313

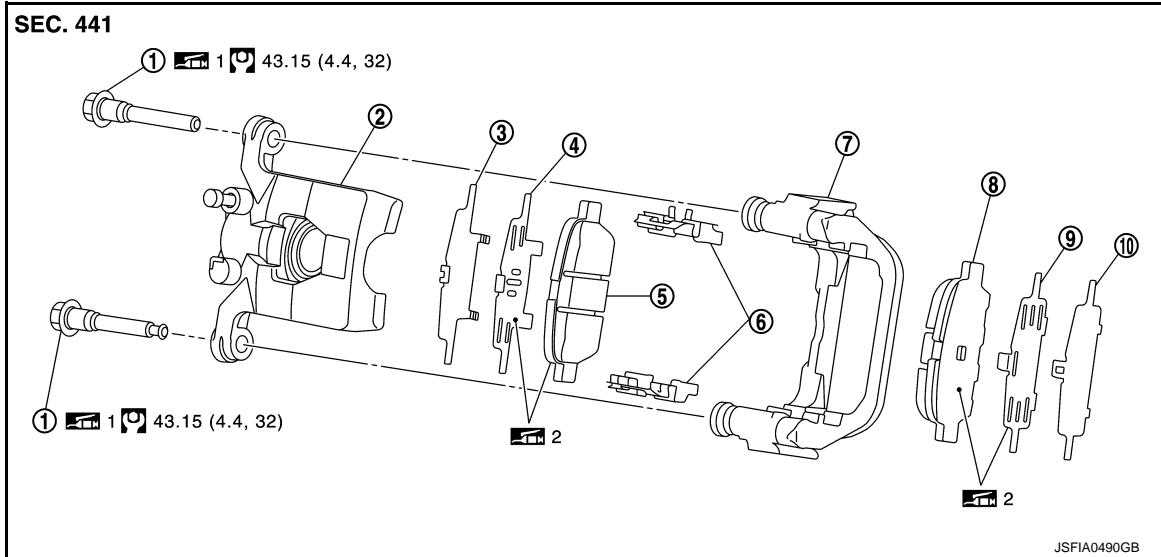

- |                      |                                     |                     |
|----------------------|-------------------------------------|---------------------|
| 1. Sliding pin bolt  | 2. Cylinder body                    | 3. Inner shim cover |
| 4. Inner shim        | 5. Inner pad (with pad wear sensor) | 6. Pad retainer     |
| 7. Torque member     | 8. Outer pad                        | 9. Outer shim       |
| 10. Outer shim cover |                                     |                     |

1 Apply rubber grease.

2: Apply MOLYKOTE® AS880N or silicone-based grease.

: N·m (kg·m, ft·lb)

Molykote is a registered trademark of Dow Corning Corporation.

### BRAKE PAD : Removal and Installation

INFOID:000000009752314

#### REMOVAL

#### **WARNING:**

Since dust covering the rear brake has an affect on human body, the dust must be removed with a dust collector. Never splatter the dust with an air blow gun.

#### **CAUTION:**

- Never depress the brake pedal while removing the brake pads because the piston may pop out.
- If the brake fluid or grease adheres to the disc rotor, quickly wipe it off.

1. Remove tires with power tool.
2. Remove lower sliding pin bolt.

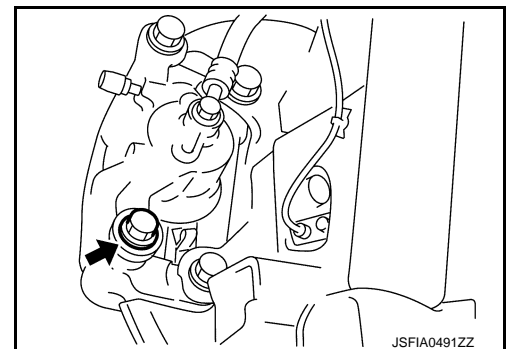

# REAR DISC BRAKE

## < REMOVAL AND INSTALLATION >

- Suspend the cylinder body with suitable wire so that the brake hose will not stretch.

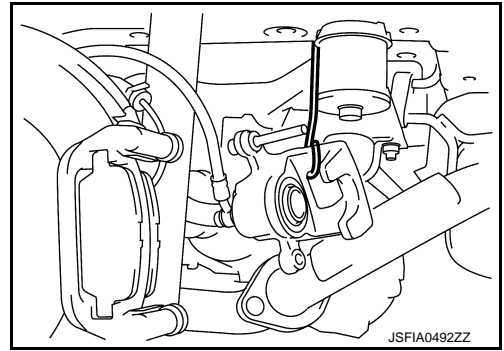

- Remove the brake pads, shims, shim covers and pad retainers from the torque member.

**CAUTION:**

- Never deform the pad retainer (2) when removing the pad retainer from the torque member (1).
- Never damage the piston boot.
- Never drop the brake pads, shims, and the shim covers.
- Remember each position of the removed brake pads.

- Perform inspection after removal. Refer to [BR-52, "BRAKE PAD : Inspection"](#).

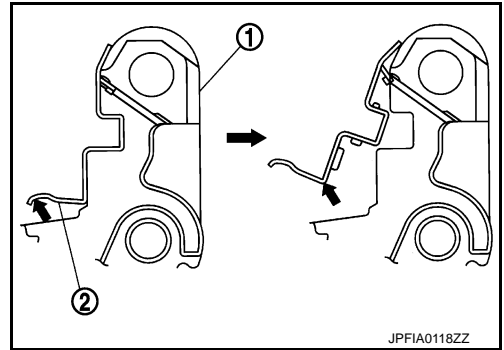

## INSTALLATION

**WARNING:**

Since dust covering the rear brake has an affect on human body, the dust must be removed with a dust collector. Never splatter the dust with an air blow gun.

**CAUTION:**

- Never depress the brake pedal while removing the brake pads or the cylinder body because the piston may pop out.
- If the brake fluid or grease adheres to the disc rotor, quickly wipe it off.

- Install the pad retainers (1) to the torque member (2) if the pad retainers has been removed.

**CAUTION:**

- Securely assemble the pad retainers so that it will not be lifted up from the torque member.
- Never deform the pad retainers.

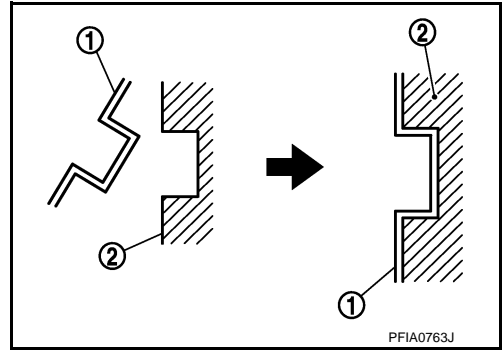

- Apply MOLYKOTE® AS880N or silicone-based grease to the mating faces (A) between the brake pads and the shims, and install the shims to the brake pad.

**CAUTION:**

**Always replace the shim together with the shim cover when replacing the brake pad.**

Molykote is a registered trademark of Dow Corning Corporation.

- Install the brake pads to the torque member.
- Install cylinder body to torque member.

**CAUTION:**

- Never damage the piston boot.

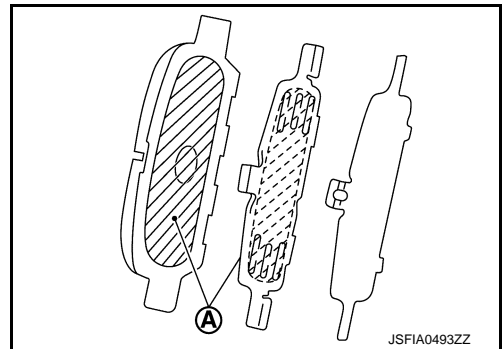

# REAR DISC BRAKE

## < REMOVAL AND INSTALLATION >

- When replacing brake pad with new one, check a brake fluid level in the reservoir tank because brake fluid returns to master cylinder reservoir tank when pressing piston in.

### NOTE:

Use a disc brake piston tool to easily press piston.

5. Install the lower sliding pin bolt and tighten it to the specified torque.
6. Depress the brake pedal several times to check that no drag feel is present for the rear disc brake. Refer to [BR-52, "BRAKE PAD : Inspection"](#).
7. Install tires. Refer to [WT-46, "Removal and Installation"](#).

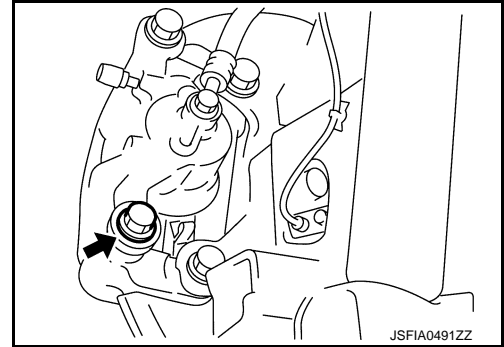

## BRAKE PAD : Inspection

INFOID:000000009752315

### INSPECTION AFTER REMOVAL

- Replace the shims and the shim covers if rust is excessively attached.
- Eliminate rust on the pad retainers and the torque member. Replace them if rust is excessively attached.

### INSPECTION AFTER INSTALLATION

1. Check a drag of rear disc brake. If any drag is found, follow the procedure described below.
2. Remove brake pads. Refer to [BR-50, "BRAKE PAD : Removal and Installation"](#).
3. Press the pistons. Refer to [BR-50, "BRAKE PAD : Removal and Installation"](#).
4. Install brake pads. Refer to [BR-50, "BRAKE PAD : Removal and Installation"](#).
5. Securely depress the brake pedal several times.
6. Check a drag of rear disc brake again. If any drag is found, disassemble the cylinder body and replace if necessary. Refer to [BR-54, "BRAKE CALIPER ASSEMBLY : Disassembly and Assembly"](#)
7. Burnish contact surfaces brake pads and disc rotor after refinishing or replacing brake pads, or if a soft pedal occurs at very low mileage. Refer to [BR-16, "BRAKE PAD : Inspection and Adjustment"](#).

## BRAKE CALIPER ASSEMBLY

### BRAKE CALIPER ASSEMBLY : Exploded View

INFOID:000000009752316

### REMOVAL

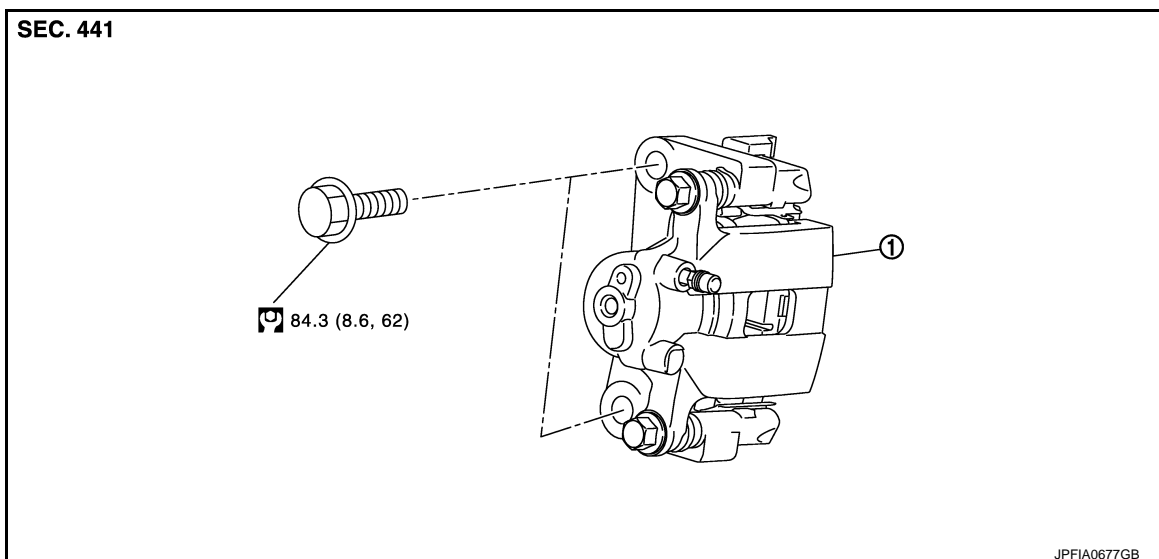

# REAR DISC BRAKE

## < REMOVAL AND INSTALLATION >

1. Brake caliper assembly

: N·m (kg·m, ft·lb)

### DISASSEMBLY

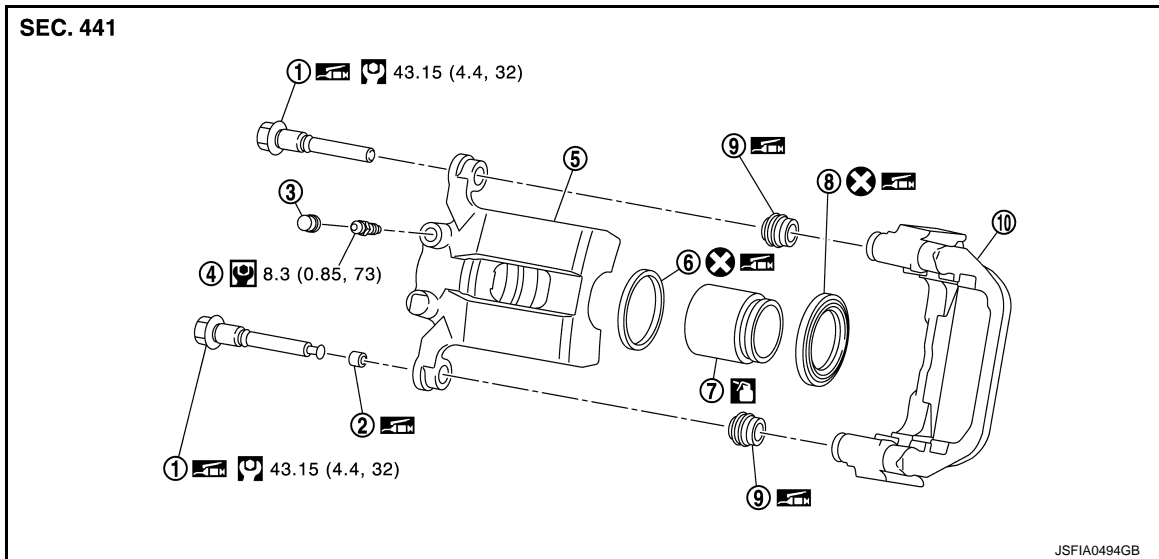

- |                     |                  |                     |
|---------------------|------------------|---------------------|
| 1. Sliding pin bolt | 2. Bushing       | 3. Cap              |
| 4. Bleeder valve    | 5. Cylinder body | 6. Piston seal      |
| 7. Piston           | 8. Piston boot   | 9. Sliding pin boot |
| 10. Torque member   |                  |                     |

: Apply rubber grease.

: Apply brake fluid.

: N·m (kg·m, ft·lb)

: N·m (kg·m, in·lb)

: Always replace after every disassembly.

### BRAKE CALIPER ASSEMBLY : Removal and Installation

INFOID:000000009752317

#### REMOVAL

##### **WARNING:**

Since dust covering the rear brake has an affect on human body, the dust must be removed with a dust collector. Never splatter the dust with an air blow gun.

##### **CAUTION:**

- Never spill or splash brake fluid on painted surfaces. Brake fluid may seriously damage paint. Wipe it out immediately and wash with water if it gets on a protect surface. For brake component parts, never wash them with water.
- Never depress the brake pedal while removing the brake hose. If this is not complied with, brake fluid may splash.
- Never drop removed parts.
- If the brake fluid or grease adheres to the disc rotor, quickly wipe it off.

1. Remove tires with power tool.
2. Fix the disc rotor using wheel nuts.
3. Drain brake fluid. Refer to [BR-10, "Draining"](#).
4. Separate brake hose from caliper assembly. Refer to [BR-27, "REAR : Removal and Installation"](#).

# REAR DISC BRAKE

## < REMOVAL AND INSTALLATION >

- Remove torque member mounting bolts, and remove brake caliper assembly.  
**CAUTION:**  
**Never drop brake pad and caliper assembly.**
- When removing disc rotor.
  - 2WD: Refer to [RAX-7, "Removal and Installation"](#).
  - AWD: Refer to [RAX-16, "Removal and Installation"](#).

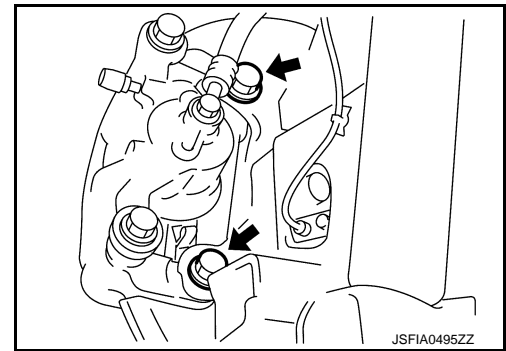

## INSTALLATION

### **WARNING:**

Since dust covering the rear brake has an affect on human body, the dust must be removed with a dust collector. Never splatter the dust with an air blow gun.

### **CAUTION:**

- Never spill or splash brake fluid on painted surfaces. Brake fluid may seriously damage paint. Wipe it out immediately and wash with water if it gets on a protect surface. For brake component parts, never wash them with water.
- Never depress the brake pedal while removing the brake hose. If this is not complied with, brake fluid may splash.
- If the brake fluid or grease adheres to the disc rotor, quickly wipe it off.

- Install disc rotor.
  - 2WD: Refer to [RAX-7, "Removal and Installation"](#).
  - AWD: Refer to [RAX-16, "Removal and Installation"](#).
- Install the brake caliper assembly to the axle housing and tighten the torque member mounting bolts to the specified torque.

### **CAUTION:**

**Never spill or splash any grease and moisture on the brake caliper assembly mounting face, threads, mounting bolts and washers. Wipe out any grease and moisture.**

- Install brake hose. Refer to [BR-27, "REAR : Removal and Installation"](#).
- Perform the air bleeding. Refer to [BR-11, "Bleeding Brake System"](#).
- Check a drag of rear disc brake. If any drag is found, refer to [BR-52, "BRAKE PAD : Inspection"](#).
- Install tires. Refer to [WT-46, "Removal and Installation"](#).
- Perform inspection after installation. Refer to [BR-56, "BRAKE CALIPER ASSEMBLY : Inspection"](#).

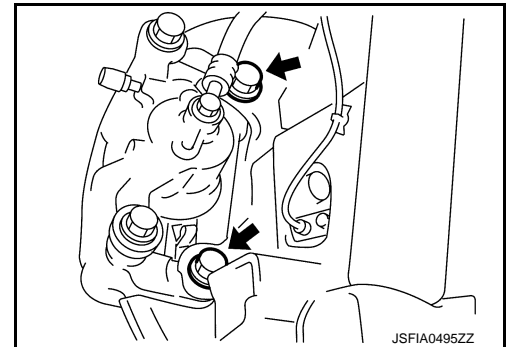

## BRAKE CALIPER ASSEMBLY : Disassembly and Assembly

INFOID:000000009752318

### DISASSEMBLY

#### **NOTE:**

Never remove the torque member, brake pad and pad retainers when disassembling and assembling the cylinder body.

- Remove the sliding pin bolt, and remove the cylinder body from the torque member. Refer to [BR-50, "BRAKE PAD : Removal and Installation"](#).  
**CAUTION:**  
**Fix the brake pad at suitable tape so that the brake pad will not drop.**
- Remove sliding pin boots from torque member.

## REAR DISC BRAKE

### < REMOVAL AND INSTALLATION >

3. Remove bushing (1) from sliding pin bolt (2).

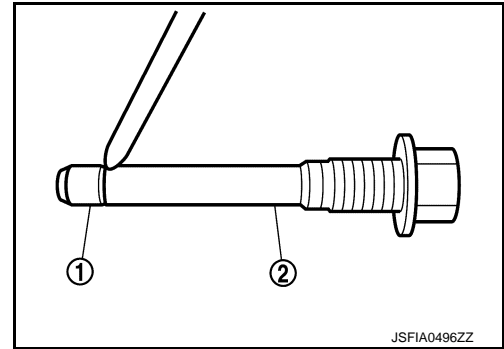

4. Place a wooden block as shown in the figure, and blow air from union bolt mounting hole to remove pistons and piston boots.

**CAUTION:**

**Never get fingers caught in the pistons.**

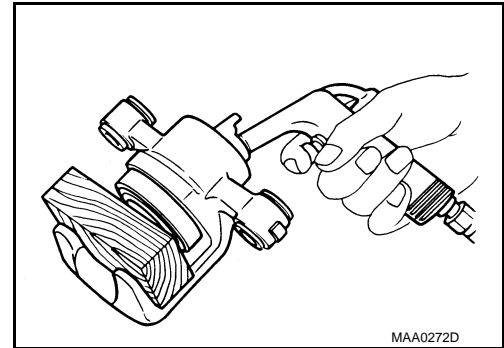

5. Remove piston seal from cylinder body using seal pick tool.

**CAUTION:**

**Be careful not to damage a cylinder inner wall.**

6. Remove bleeder valve and cap.
7. Perform inspection after disassembly. Refer to [BR-56. "BRAKE CALIPER ASSEMBLY : Inspection"](#).

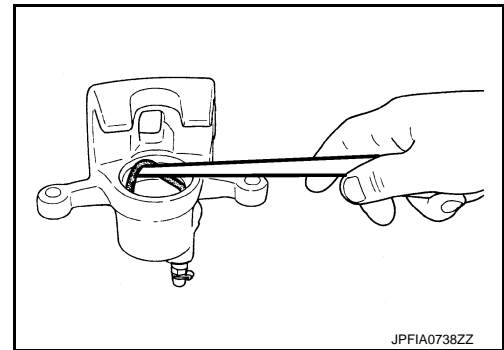

### ASSEMBLY

1. Install bleeder valve and cap.
2. Apply rubber grease to piston seals (1), and install them to cylinder body.

**CAUTION:**

**Never reuse piston seals.**

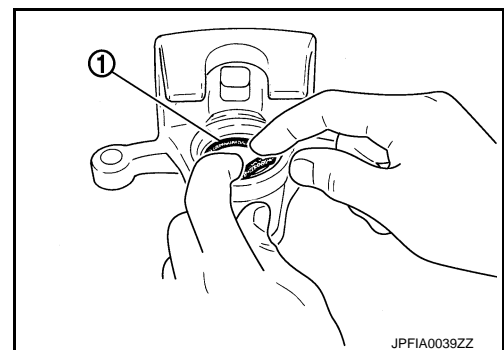

A  
B  
C  
D  
E  
BR  
G  
H  
I  
J  
K  
L  
M  
N  
O  
P

# REAR DISC BRAKE

## < REMOVAL AND INSTALLATION >

3. Apply rubber grease to piston boots (1). Cover the piston (2) end with piston boot, and then install cylinder side lip on piston boot securely into a groove on cylinder body.

**CAUTION:**

**Never reuse piston boots.**

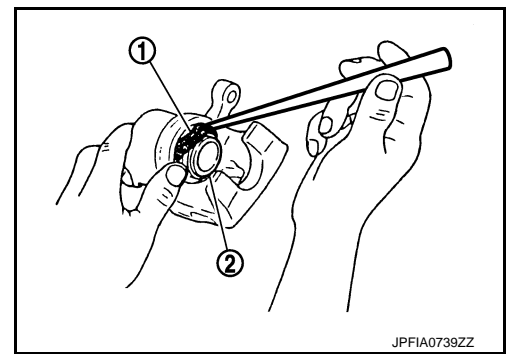

4. Apply new brake fluid to pistons (1). Push piston into cylinder body by hand and push piston boot (2) piston-side lip into the piston groove.

**CAUTION:**

**Press the pistons evenly and vary the pressing point to prevent cylinder inner wall from being rubbed.**

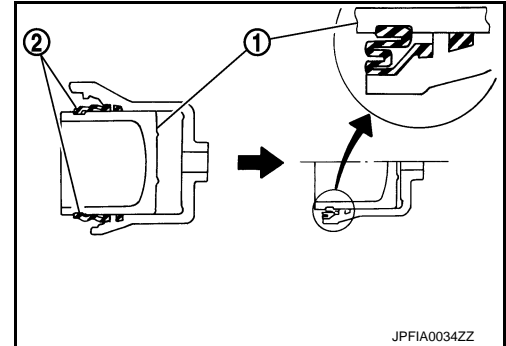

5. Apply rubber grease to mating faces (A) between sliding pin bolt (1) and bushing (2), and install bushing to sliding pin.

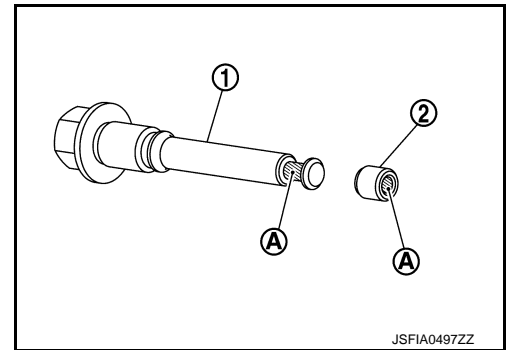

6. Apply rubber grease to mating faces (A) between sliding pin bolt (1) and sliding pin boot (2), and install sliding pin and sliding pin boot to sliding torque member.

7. Install the cylinder body to tighten sliding pin bolts to the specified torque. Refer to [BR-50, "BRAKE PAD : Exploded View"](#).

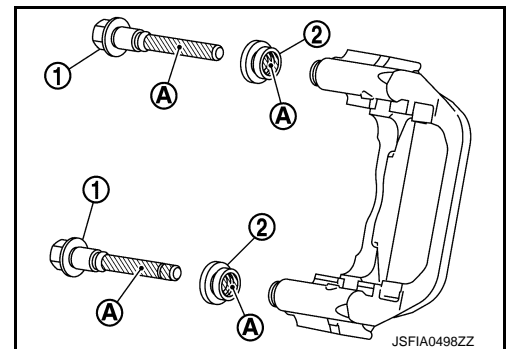

## BRAKE CALIPER ASSEMBLY : Inspection

INFOID:000000009752319

### INSPECTION AFTER DISASSEMBLY

Check the following items and replace if necessary.

#### Cylinder Body

Check the inner wall of the cylinder for rust, wear, cracks or damage.

**CAUTION:**

**Always clean with new brake fluid. Never clean with mineral oil such as gasoline and light oil.**

#### Torque Member

Check the torque member for rust, wear, cracks or damage.



# REAR DISC BRAKE

## < REMOVAL AND INSTALLATION >

---

### Pistons

Check the surface of the piston for rust, wear, cracks or damage.

**CAUTION:**

**A piston sliding surface is plated. Never polish with sandpaper.**

### Sliding Pin, Sliding Pin Boot and Bushing

Check the sliding pins, sliding boots and bushing for rust, wear, cracks or damage.

## INSPECTION AFTER INSTALLATION

1. Check a drag of rear disc brake. If any drag is found, follow the procedure described below.
2. Remove brake pads. Refer to [BR-50. "BRAKE PAD : Removal and Installation"](#).
3. Press the pistons. Refer to [BR-50. "BRAKE PAD : Removal and Installation"](#).
4. Install brake pads. Refer to [BR-50. "BRAKE PAD : Removal and Installation"](#).
5. Securely depress the brake pedal several times.
6. Check a drag of rear disc brake again. If any drag is found, disassemble the cylinder body and replace if necessary. Refer to [BR-54. "BRAKE CALIPER ASSEMBLY : Disassembly and Assembly"](#).
7. Burnish contact surface between disc rotor and brake pads after refinishing or replacing disc rotor, or if a soft pedal occurs at very low mileage. Refer to [BR-16. "DISC ROTOR : Inspection and Adjustment"](#).

A  
B  
C  
D  
E  
BR  
G  
H  
I  
J  
K  
L  
M  
N  
O  
P

## SERVICE DATA AND SPECIFICATIONS (SDS)

< SERVICE DATA AND SPECIFICATIONS (SDS)

# SERVICE DATA AND SPECIFICATIONS (SDS)

## SERVICE DATA AND SPECIFICATIONS (SDS)

### General Specifications

INFOID:000000009752320

#### FOR NISMO RS

Unit: mm (in)

Front brake	Cylinder bore diameter	57.2 (2.252)
	Pad length × width × thickness	123.6 × 47.5 × 11.0 (4.87 × 1.870 × 0.433)
	Rotor outer diameter × thickness	320 × 28.0 (12.60 × 1.102)
Rear brake	Cylinder bore diameter	34.93 (1.3752)
	Pad length × width × thickness	83.0 × 31.9 × 8.5 (3.268 × 1.256 × 0.335)
	Rotor outer diameter × thickness	292 × 16.0 (11.50 × 0.630)
Master cylinder	Cylinder bore diameter	23.8 (15/16)
Control valve	Valve type	Electric brake force distribution
Brake booster	Diaphragm diameter	256 (10)
Recommended brake fluid		Refer to <a href="#">MA-10. "Fluids and Lubricants"</a> .

#### EXCEPT FOR NISMO RS

Unit: mm (in)

Front brake	Cylinder bore diameter	57.2 (2.252)
	Pad length × width × thickness	126.0 × 46.0 × 11.0 (4.96 × 1.811 × 0.433)
	Rotor outer diameter × thickness	296 × 26.0 (11.65 × 1.024)
Rear brake	Cylinder bore diameter	34.93 (1.3752)
	Pad length × width × thickness	83.0 × 31.9 × 8.5 (3.268 × 1.256 × 0.335)
	Rotor outer diameter × thickness	292 × 9.0 (11.50 × 0.354)
Master cylinder	Cylinder bore diameter	23.8 (15/16)
Control valve	Valve type	Electric brake force distribution
Brake booster	Diaphragm diameter	256 (10)
Recommended brake fluid		Refer to <a href="#">MA-10. "Fluids and Lubricants"</a> .

### Brake Pedal

INFOID:000000009752321

Unit: mm (in)

Item	Standard
Brake pedal height	160.4 – 170.4 (6.31 – 6.71)
Depressed brake pedal height [Depressing 490 N (50 kg, 110 lb) while turning the engine ON]	70.0 (2.756) or more
Clearance between stop lamp switch and brake pedal position switch threaded end and the brake pedal lever	0.74 – 1.96 (0.0291 – 0.0772)
Brake pedal play	3 – 11 (0.12 – 0.43)

### Brake Booster

INFOID:000000009752322

Unit: mm (in)

Item	Standard
Input rod length	156.5 – 157.5 (6.16 – 6.20)

# SERVICE DATA AND SPECIFICATIONS (SDS)

## < SERVICE DATA AND SPECIFICATIONS (SDS)

### Front Disc Brake

INFOID:000000009752323

Unit: mm (in)

Item		Limit
Brake pad	Wear thickness	2.0 (0.079)
	Wear thickness	24.0 (0.945)
Disc rotor	Thickness variation (measured at 8 positions)	0.008 (0.0003)
	Runout (with it attached to the vehicle)	0.035 (0.0014)

### Rear Disc Brake

INFOID:000000009752324

Unit: mm (in)

Item		Limit
Brake pad	Wear thickness	2.0 (0.079)
	Wear thickness	8.0 (0.315)
Disc rotor	Thickness variation (measured at 8 positions)	0.016 (0.0006)
	Runout (with it attached to the vehicle)	0.1 (0.004)

A  
B  
C  
D  
E  
BR  
G  
H  
I  
J  
K  
L  
M  
N  
O  
P