

SECTION **BRC**

BRAKE CONTROL SYSTEM

A
B
C
D
E

CONTENTS

WITH VDC	TCS FUNCTION31	BRC
PRECAUTION 4	TCS FUNCTION : System Description32	
PRECAUTIONS 4	ABS FUNCTION33	G
Precaution for Supplemental Restraint System (SRS) "AIR BAG" and "SEAT BELT PRE-TENSIONER"4	ABS FUNCTION : System Description33	
Precaution for Procedure without Cowl Top Cover.....4	EBD FUNCTION35	H
Precautions for Removing of Battery Terminal5	EBD FUNCTION : System Description35	
Precaution for Brake System5	BRAKE LIMITED SLIP DIFFERENTIAL (BLSD) FUNCTION36	I
Precaution for Brake Control system5	BRAKE LIMITED SLIP DIFFERENTIAL (BLSD) FUNCTION : System Description36	
Precaution for Harness Repair7	DIAGNOSIS SYSTEM [ABS ACTUATOR AND ELECTRIC UNIT (CONTROL UNIT)]39	J
PREPARATION 8	CONSULT Function39	
PREPARATION 8	ECU DIAGNOSIS INFORMATION44	K
Commercial Service Tool8	ABS ACTUATOR AND ELECTRIC UNIT (CONTROL UNIT)44	L
SYSTEM DESCRIPTION 9	Reference Value44	
COMPONENT PARTS 9	Fail-safe46	M
Component Parts Location9	DTC Inspection Priority Chart49	
Component Description 11	DTC Index50	N
Wheel Sensor and Sensor Rotor 11	WIRING DIAGRAM52	
ABS Actuator and Electric Unit (Control Unit) 12	BRAKE CONTROL SYSTEM52	O
Stop Lamp Switch 13	Wiring Diagram52	
Brake Pedal Position Switch 13	BASIC INSPECTION58	P
Steering Angle Sensor 13	DIAGNOSIS AND REPAIR WORK FLOW58	
Yaw Rate/Side/Decel G Sensor 13	Work Flow58	
VDC OFF Switch 13	Diagnostic Work Sheet59	
Brake Fluid Level Switch 13	ADDITIONAL SERVICE WHEN REPLACING ABS ACTUATOR AND ELECTRIC UNIT (CONTROL UNIT)61	
Parking Brake Switch 13	Description61	
SYSTEM14		
System Description 14		
Fail-safe 25		
VDC FUNCTION28		
VDC FUNCTION : System Description28		

ADJUSTMENT OF STEERING ANGLE SENSOR NEUTRAL POSITION	62	Diagnosis Procedure	96
Description	62	C1143 STEERING ANGLE SENSOR	98
Work Procedure	62	DTC Logic	98
DTC/CIRCUIT DIAGNOSIS	64	Diagnosis Procedure	98
C1101, C1102, C1103, C1104 WHEEL SENSOR	64	C1144 INCOMPLETE STEERING ANGLE SENSOR ADJUSTMENT	100
DTC Logic	64	DTC Logic	100
Diagnosis Procedure	64	Diagnosis Procedure	100
C1105, C1106, C1107, C1108 WHEEL SENSOR	67	C1155 BRAKE FLUID LEVEL SWITCH	101
DTC Logic	67	DTC Logic	101
Diagnosis Procedure	68	Diagnosis Procedure	101
C1109 POWER AND GROUND SYSTEM	73	Component Inspection	103
DTC Logic	73	C1164, C1165 CV SYSTEM	104
Diagnosis Procedure	73	DTC Logic	104
C1110, C1170 ABS ACTUATOR AND ELECTRIC UNIT (CONTROL UNIT)	75	Diagnosis Procedure	104
DTC Logic	75	C1166, C1167 SV SYSTEM	106
Diagnosis Procedure	75	DTC Logic	106
C1111 ABS MOTOR, MOTOR RELAY SYSTEM	76	Diagnosis Procedure	106
DTC Logic	76	C1176 STOP LAMP SW2	108
Diagnosis Procedure	76	DTC Logic	108
C1113, C1145, C1146 YAW RATE/SIDE/DECEL G SENSOR	78	Diagnosis Procedure	108
DTC Logic	78	Component Inspection	111
Diagnosis Procedure	78	U1000 CAN COMM CIRCUIT	112
C1115 WHEEL SENSOR	81	Description	112
DTC Logic	81	DTC Logic	112
Diagnosis Procedure	81	Diagnosis Procedure	112
C1116 STOP LAMP SWITCH	87	U1010 CONTROL UNIT (CAN)	113
DTC Logic	87	Description	113
Diagnosis Procedure	87	DTC Logic	113
Component Inspection	90	Diagnosis Procedure	113
C1120, C1122, C1124, C1126 ABS IN VALVE SYSTEM	91	POWER SUPPLY AND GROUND CIRCUIT ...	114
DTC Logic	91	Diagnosis Procedure	114
Diagnosis Procedure	91	PARKING BRAKE SWITCH	117
C1121, C1123, C1125, C1127 ABS OUT VALVE SYSTEM	93	Component Function Check	117
DTC Logic	93	Diagnosis Procedure	117
Diagnosis Procedure	93	Component Inspection	117
C1130 ENGINE SIGNAL	95	VDC OFF SWITCH	119
DTC Logic	95	Component Function Check	119
Diagnosis Procedure	95	Diagnosis Procedure	119
C1140 ACTUATOR RELAY SYSTEM	96	Component Inspection	120
DTC Logic	96	ABS WARNING LAMP	121
		Component Function Check	121
		Diagnosis Procedure	121
		BRAKE WARNING LAMP	122
		Component Function Check	122
		Diagnosis Procedure	122
		VDC WARNING LAMP	123
		Component Function Check	123

Diagnosis Procedure	123	WHEEL SENSOR	132	A
VDC OFF INDICATOR LAMP	124	FRONT WHEEL SENSOR	132	B
Component Function Check	124	FRONT WHEEL SENSOR : Exploded View	132	
Diagnosis Procedure	124	FRONT WHEEL SENSOR : Removal and Instal-		
SYMPTOM DIAGNOSIS	125	lation	132	B
EXCESSIVE OPERATION FREQUENCY	125	REAR WHEEL SENSOR	133	C
Description	125	REAR WHEEL SENSOR : Exploded View	133	
Diagnosis Procedure	125	REAR WHEEL SENSOR : Removal and Installa-		
UNEXPECTED BRAKE PEDAL REACTION ..	126	tion	135	D
Description	126	SENSOR ROTOR	137	E
Diagnosis Procedure	126	FRONT SENSOR ROTOR	137	
THE BRAKING DISTANCE IS LONG	127	FRONT SENSOR ROTOR : Removal and Instal-		
Description	127	lation	137	
Diagnosis Procedure	127	REAR SENSOR ROTOR	137	
DOES NOT OPERATE	128	REAR SENSOR ROTOR : Removal and Installa-		
Description	128	tion	137	BRC
Diagnosis Procedure	128	ABS ACTUATOR AND ELECTRIC UNIT		
BRAKE PEDAL VIBRATION OR OPERA-		(CONTROL UNIT)	138	G
TION SOUND OCCURS	129	Exploded View	138	
Description	129	Removal and Installation	138	H
Diagnosis Procedure	129	YAW RATE/SIDE/DECEL G SENSOR	140	I
VEHICLE JERKS DURING	130	Exploded View	140	
Description	130	Removal and Installation	140	
Diagnosis Procedure	130	STEERING ANGLE SENSOR	141	J
NORMAL OPERATING CONDITION	131	Removal and Installation	141	
Description	131	VDC OFF SWITCH	142	K
REMOVAL AND INSTALLATION	132	Removal and Installation	142	L
				M
				N
				O
				P

PRECAUTION

PRECAUTIONS

Precaution for Supplemental Restraint System (SRS) "AIR BAG" and "SEAT BELT PRE-TENSIONER"

INFOID:000000009752877

The Supplemental Restraint System such as "AIR BAG" and "SEAT BELT PRE-TENSIONER", used along with a front seat belt, helps to reduce the risk or severity of injury to the driver and front passenger for certain types of collision. This system includes seat belt switch inputs and dual stage front air bag modules. The SRS system uses the seat belt switches to determine the front air bag deployment, and may only deploy one front air bag, depending on the severity of a collision and whether the front occupants are belted or unbelted. Information necessary to service the system safely is included in the "SRS AIR BAG" and "SEAT BELT" of this Service Manual.

WARNING:

Always observe the following items for preventing accidental activation.

- To avoid rendering the SRS inoperative, which could increase the risk of personal injury or death in the event of a collision that would result in air bag inflation, all maintenance must be performed by an authorized NISSAN/INFINITI dealer.
- Improper maintenance, including incorrect removal and installation of the SRS, can lead to personal injury caused by unintentional activation of the system. For removal of Spiral Cable and Air Bag Module, see "SRS AIR BAG".
- Never use electrical test equipment on any circuit related to the SRS unless instructed to in this Service Manual. SRS wiring harnesses can be identified by yellow and/or orange harnesses or harness connectors.

PRECAUTIONS WHEN USING POWER TOOLS (AIR OR ELECTRIC) AND HAMMERS

WARNING:

Always observe the following items for preventing accidental activation.

- When working near the Air Bag Diagnosis Sensor Unit or other Air Bag System sensors with the ignition ON or engine running, never use air or electric power tools or strike near the sensor(s) with a hammer. Heavy vibration could activate the sensor(s) and deploy the air bag(s), possibly causing serious injury.
- When using air or electric power tools or hammers, always switch the ignition OFF, disconnect the battery, and wait at least 3 minutes before performing any service.

Precaution for Procedure without Cowl Top Cover

INFOID:000000009752878

When performing the procedure after removing cowl top cover, cover the lower end of windshield with urethane, etc to prevent damage to windshield.

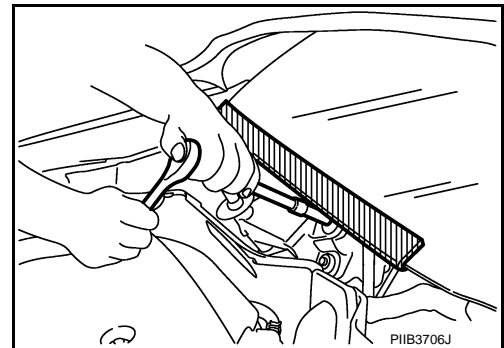

PRECAUTIONS

< PRECAUTION >

[WITH VDC]

Precautions for Removing of Battery Terminal

INFOID:000000010200467

- When removing the 12V battery terminal, turn OFF the ignition switch and wait at least 30 seconds.

NOTE:

ECU may be active for several tens of seconds after the ignition switch is turned OFF. If the battery terminal is removed before ECU stops, then a DTC detection error or ECU data corruption may occur.

- For vehicles with the 2-batteries, be sure to connect the main battery and the sub battery before turning ON the ignition switch.

NOTE:

If the ignition switch is turned ON with any one of the terminals of main battery and sub battery disconnected, then DTC may be detected.

- After installing the 12V battery, always check "Self Diagnosis Result" of all ECUs and erase DTC.

NOTE:

The removal of 12V battery may cause a DTC detection error.

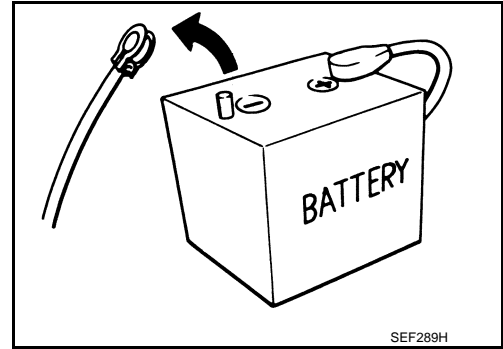

Precaution for Brake System

INFOID:000000009752879

WARNING:

Since dust covering the front and rear brakes has an affect on human body, the dust must be removed with a dust collector. Never splatter the dust with an air blow gun.

- Brake fluid use refer to [MA-10, "Fluids and Lubricants"](#).
- Never reuse drained brake fluid.
- Never spill or splash brake fluid on painted surfaces. Brake fluid may seriously damage paint. Wipe it off immediately and wash with water if it gets on a painted surface.
- Always confirm the specified tightening torque when installing the brake pipes.
- After pressing the brake pedal more deeply or harder than normal driving, such as air bleeding, check the each item of brake pedal. Adjust brake pedal if it is outside the standard value.
- Never use mineral oils such as gasoline or light oil to clean. They may damage rubber parts and cause improper operation.
- Always loosen the brake tube flare nut with a flare nut wrench.
- Tighten the brake tube flare nut to the specified torque with a crow-foot (A) and torque wrench (B).
- Turn the ignition switch OFF and disconnect the ABS actuator and electric unit (control unit) harness connector or the battery negative terminal before performing the work.
- Check that no brake fluid leakage is present after replacing the parts.

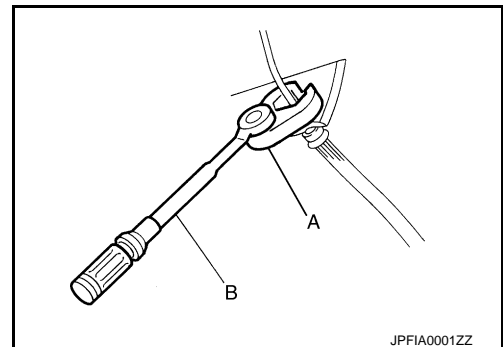

Precaution for Brake Control system

INFOID:000000009752880

- Always perform a pre-driving check to drive the vehicle.
- Always check speed and safety while driving the vehicle.
- To operate CONSULT while driving, more than one person is required to be in the vehicle to avoid interference to driving and ensure safety.
- Slight vibrations are felt on the brake pedal and the operation noises occur, when VDC function, TCS function, ABS function EBD function or brake limited slip differential (BLSD) function operates. This is not a malfunction because it is caused by VDC function, TCS function, ABS function EBD function or brake limited slip differential (BLSD) function that is normally operated.
- When starting engine or when starting vehicle just after starting engine, brake pedal may vibrate or motor operating noise may be heard from engine compartment. This is normal condition.
- Brake stopping distance may become longer than models without ABS function depending on the road conditions, when ABS function is operated on slippery road like rough road, gravel road or snowy road.

PRECAUTIONS

[WITH VDC]

< PRECAUTION >

- When a malfunction is indicated, always collect information from the customer about conditions of occurrence, estimate cause and perform operation. Check brake booster operation, brake fluid level and brake fluid leakage, as well as electrical system.
- The optimum performance is achieved by control for VDC function, TCS function, ABS function EBD function and brake limited slip differential (BLSD) function when all of brakes, suspensions and tires installed on the vehicle are the specified size and parts. Brake performance and controllability may be negatively affected when other parts than the specified are installed.
- Brake stopping distance may become longer and steering stability may be negatively affected, when tires in different size and combination or other parts than the specified are used.
- When a radio (including wiring), antenna and antenna lead line are located near ABS actuator and electric unit (control unit), a malfunction or improper operation may occur for the control of VDC function, TCS function, ABS function EBD function and brake limited slip differential (BLSD) function.
- When the following items are replaced by other parts than genuine parts or modified, ABS warning lamp, brake warning lamp and VDC warning lamp may turn ON, and the control may not operate normally for VDC function, TCS function, ABS function EBD function and brake limited slip differential (BLSD) function.
 - Suspension component parts (shock absorber, spring, bushing and others)
 - Tire and wheel (other than the specified size)
 - Brake component parts (brake pad, disc rotor, brake caliper and others)
 - Engine component parts (ECM, muffler and others)
 - Body reinforcement component parts (rollover bar, tower bar and others)
- When suspension, tire and brake component parts are excessively worn or deteriorated and the vehicle is driven, ABS warning lamp, brake warning lamp and VDC warning lamp may turn ON, and the control may not operate normally for VDC function, TCS function, ABS function EBD function and brake limited slip differential (BLSD) function.
- ABS warning lamp, brake warning lamp and VDC warning lamp may turn ON, when only front wheel or rear wheel is rotated using a free roller. This is not a malfunction, because it is caused by wheel speed difference between wheel that is rotated and wheel that is not rotated. In this case, perform self-diagnosis, check self-diagnosis results, and erase memory.
- When power supply voltage is not normal, ABS warning lamp, brake warning lamp and VDC warning lamp turn ON. ABS actuator and electric unit (control unit) stops control for VDC function, TCS function, ABS function EBD function and brake limited slip differential (BLSD) function. Ordinary brake operates. After power supply returns to normal, ABS warning lamp, brake warning lamp and VDC warning lamp turn OFF. The control becomes operative for VDC function, TCS function, ABS function EBD function and brake limited slip differential (BLSD) function.
- Brake pedal vibrates and operation sound occurs during sudden acceleration and cornering, when VDC function, TCS function or brake limited slip differential (BLSD) function is operated. This is not a malfunction because it is caused by VDC function, TCS function or brake limited slip differential (BLSD) function that is operated normally.
- VDC warning lamp may turn ON and VDC function, TCS function and brake limited slip differential (BLSD) function may not normally operate, when driving on a special road that is extremely slanted (bank in a circuit course). This is not a malfunction if the status returns to normal for VDC function, TCS function and brake limited slip differential (BLSD) function after the engine is started again. In this case, perform self-diagnosis, check self-diagnosis results, and erase memory.
- A malfunction in yaw rate/side/decel G sensor system may be detected when the vehicle sharply turns during a spin turn, acceleration turn or drift driving while VDC function, TCS function and brake limited slip differential (BLSD) function are OFF (VDC OFF switch is pressed and VDC OFF indicator lamp is in ON status). This is not a malfunction if the status returns to normal for VDC function, TCS function and brake limited slip differential (BLSD) function after the engine is started again. In this case, perform self-diagnosis, check self-diagnosis results, and erase memory.

PRECAUTIONS

[WITH VDC]

< PRECAUTION >

Precaution for Harness Repair

INFOID:000000009752881

- Solder the repair part, and wrap it with tape. [Twisted wire fray must be 110 mm (4.33 in) or less.]

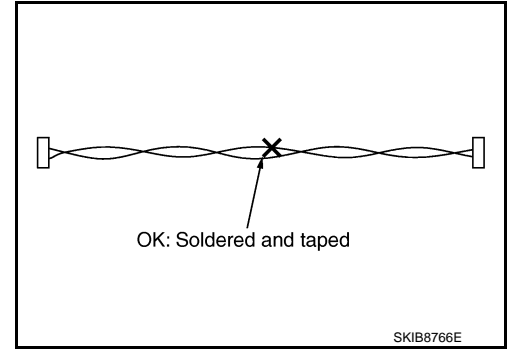

- Never bypass the repair point with wire. (If it is bypassed, the turnout point cannot be separated and the twisted wire characteristics are lost.)

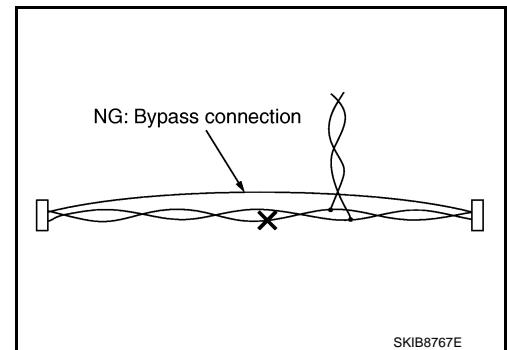

A
B
C
D
E
BRC
G
H
I
J
K
L
M
N
O
P

< PREPARATION >

PREPARATION

PREPARATION

Commercial Service Tool

INFOID:000000009752882

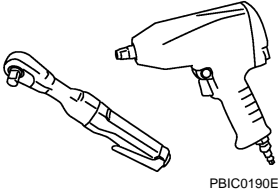
Tool name	Description
<p>Power tool</p>  <p>PBIC0190E</p>	<p>Loosening bolts and nuts</p>

SYSTEM DESCRIPTION

COMPONENT PARTS

Component Parts Location

INFOID:000000009752883

2WD

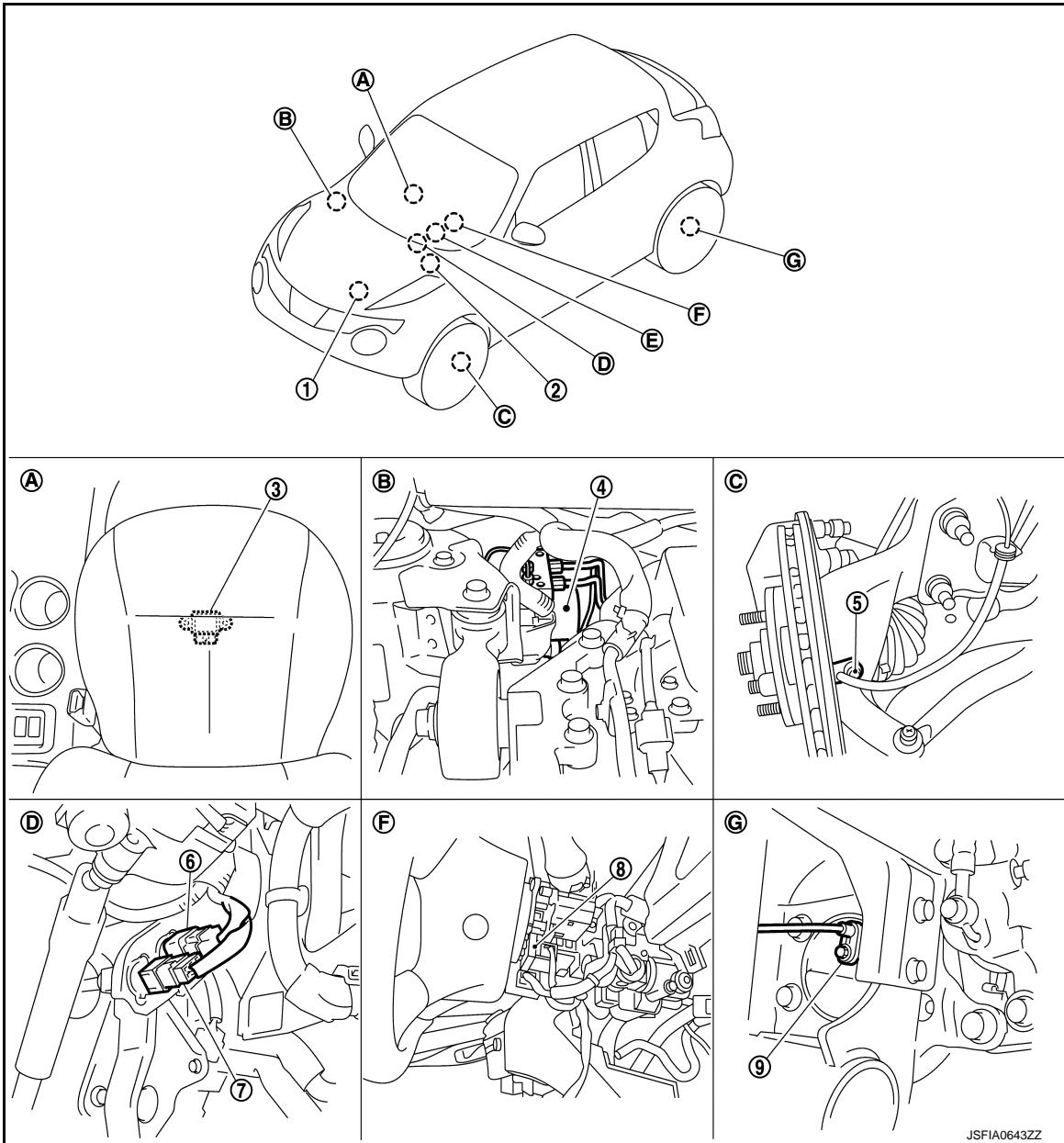

- | | | |
|--|---|---------------------------------|
| 1. ECM
Refer to EC-14, "ENGINE CONTROL SYSTEM : Component Parts Location" . | 2. TCM*
Refer to TM-150, "CVT CONTROL SYSTEM : Component Parts Location" . | 3. Yaw rate/side/decel G sensor |
| 4. ABS actuator and electric unit (control unit) | 5. Front wheel sensor | 6. Stop lamp switch |
| 7. Brake pedal position switch | 8. Steering angle sensor | 9. Rear wheel sensor |
| A. Under floor carpet (front seat right side) | B. Inside engine room | C. Steering knuckle |

A
B
C
D
E
BRC
G
H
I
J
K
L
M
N
O
P

COMPONENT PARTS

[WITH VDC]

< SYSTEM DESCRIPTION >

- D. Brake pedal
- E. ABS warning lamp, brake warning lamp, VDC warning lamp, VDC OFF indicator lamp (in combination meter)
- F. Back of spiral cable assembly
- G. Rear wheel hub and bearing assembly
- G. Rear wheel hub and bearing assembly

*: Models with CVT

AWD

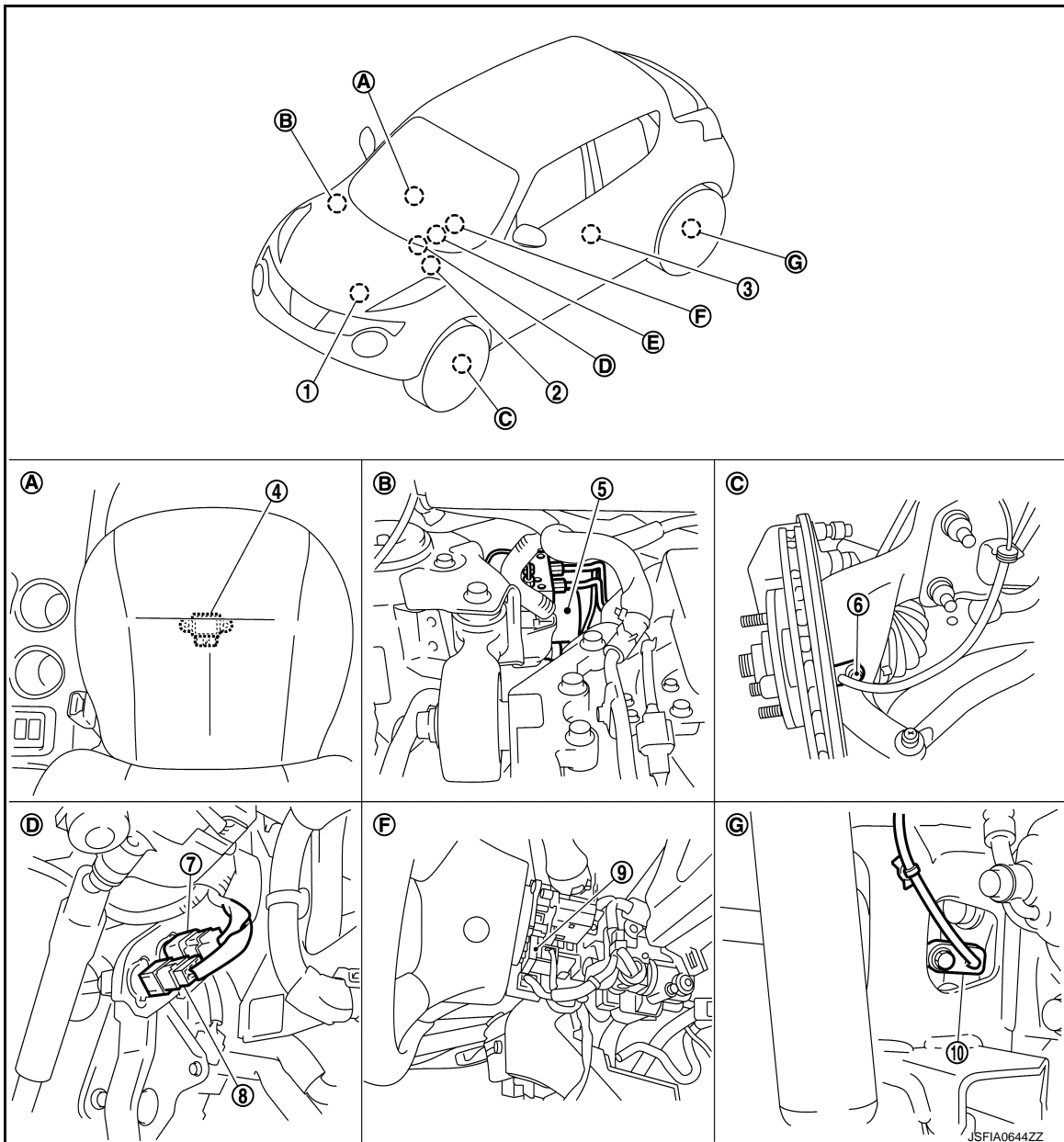

- 1. ECM
Refer to [EC-14, "ENGINE CONTROL SYSTEM : Component Parts Location"](#).
- 2. TCM
Refer to [TM-150, "CVT CONTROL SYSTEM : Component Parts Location"](#).
- 3. AWD control module
Refer to [DLN-10, "Component Parts Location"](#).
- 4. Yaw rate/side/decel G sensor
- 5. ABS actuator and electric unit (control unit)
- 6. Front wheel sensor
- 7. Stop lamp switch
- 8. Brake pedal position switch
- 9. Steering angle sensor
- 10. Rear wheel sensor

COMPONENT PARTS

[WITH VDC]

< SYSTEM DESCRIPTION >

- | | | |
|---|--|----------------------------------|
| A. Under floor carpet (front seat right side) | B. Inside engine room | C. Steering knuckle |
| D. Brake pedal | E. ABS warning lamp, brake warning lamp, VDC warning lamp, VDC OFF indicator lamp (in combination meter) | F. Back of spiral cable assembly |
| G. Rear axle housing | | |

Component Description

INFOID:000000009752884

Component	Reference/Function
ABS actuator and electric unit (control unit)	BRC-12. "ABS Actuator and Electric Unit (Control Unit)"
Wheel sensor	BRC-11. "Wheel Sensor and Sensor Rotor"
Stop lamp switch	BRC-13. "Stop Lamp Switch"
Brake pedal position switch	BRC-13. "Brake Pedal Position Switch"
Steering angle sensor	BRC-13. "Steering Angle Sensor"
Yaw rate/side/decel G sensor	BRC-13. "Yaw Rate/Side/Decel G Sensor"
VDC OFF switch	BRC-13. "VDC OFF Switch"
Brake fluid level switch	BRC-13. "Brake Fluid Level Switch"
Parking brake switch	BRC-13. "Parking Brake Switch"
VDC warning lamp	BRC-14. "System Description"
ABS warning lamp	
Brake warning lamp	
VDC OFF indicator lamp	
ECM	Mainly transmits the following signals to ABS actuator and electric unit (control unit) via CAN communication. <ul style="list-style-type: none"> • Accelerator pedal position signal • Engine speed signal Mainly receives the following signals from ABS actuator and electric unit (control unit) via CAN communication. <ul style="list-style-type: none"> • Target throttle position signal
TCM ^{*1}	Mainly transmits the following signals to ABS actuator and electric unit (control unit) via CAN communication. <ul style="list-style-type: none"> • N range signal • P range signal • R range signal • Current gear position signal
AWD control module ^{*2}	Mainly transmits the following signals to ABS actuator and electric unit (control unit) via CAN communication. <ul style="list-style-type: none"> • Current AWD mode signal

*1: Models with CVT

*2: AWD models

Wheel Sensor and Sensor Rotor

INFOID:000000009752885

NOTE:

- Wheel sensor of front wheel is installed on steering knuckle.
- Sensor rotor of front wheel is integrated in wheel hub and bearing assembly.
- Wheel sensor of rear wheel is installed on wheel hub and bearing assembly. (2WD)
- Wheel sensor of rear wheel is installed on axle housing. (AWD)
- Sensor rotor of rear wheel is integrated in wheel hub and bearing assembly. (2WD)
- Sensor rotor of rear wheel is integrated on drive shaft. (AWD)
- Never measure resistance and voltage value using a tester because sensor is active sensor.

COMPONENT PARTS

[WITH VDC]

< SYSTEM DESCRIPTION >

- Downsize and weight reduction is aimed. IC for detection portion and magnet for sensor rotor are adopted.
- Power supply is supplied to detection portion so that magnetic field line is read. Magnetic field that is detected is converted to current signal.
- When sensor rotor rotates, magnetic field changes. Magnetic field change is converted to current signals (rectangular wave) and is transmitted to ABS actuator and electric unit (control unit). Change of magnetic field is proportional to wheel speed.

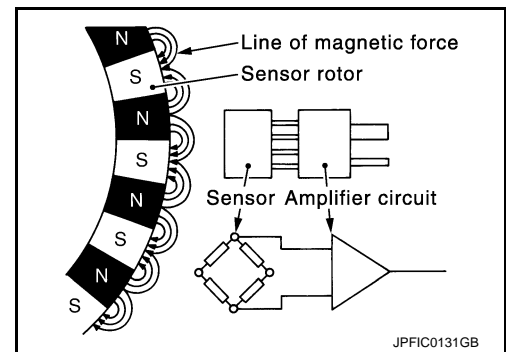

ABS Actuator and Electric Unit (Control Unit)

INFOID:000000009752886

Electric unit (control unit) is integrated with actuator and comprehensively controls VDC function, TCS function, ABS function, EBD function and brake limited slip differential (BLSD) function.

ELECTRIC UNIT (CONTROL UNIT)

- Brake fluid pressure, engine and transaxle are controlled according to signals from each sensor.
- If malfunction is detected, the system enters fail-safe mode.

ACTUATOR

The following components are integrated with ABS actuator.

Pump

Returns the brake fluid reserved in reservoir to master cylinder by reducing pressure.

Motor

Activates the pump according to signals from ABS actuator and electric unit (control unit).

Motor Relay

Operates the motor ON/OFF according to signals from ABS actuator and electric unit (control unit).

Actuator Relay (Main Relay)

Operates each valve ON/OFF according to signals from ABS actuator and electric unit (control unit).

ABS IN Valve

Switches the fluid pressure line to increase or hold according to signals from control unit.

NOTE:

Valve is a solenoid valve.

ABS OUT Valve

Switches the fluid pressure line to increase, hold or decrease according to signals from control unit.

NOTE:

Valve is a solenoid valve.

Cut Valve 1, Cut Valve 2

Shuts off the ordinary brake line from master cylinder, when VDC function, TCS function and brake limited slip differential (BLSD) function are activated.

Suction Valve 1, Suction Valve 2

Supplies the brake fluid from master cylinder to the pump, when VDC function, TCS function and brake limited slip differential (BLSD) function are activated.

Inlet Valve

Brake fluid sucked from the reservoir by the pump does not backflow.

NOTE:

Valve is a check valve.

Outlet Valve

Brake fluid discharged from the pump does not backflow.

NOTE:

Valve is a check valve.

Return Check Valve

Returns the brake fluid from brake caliper to master cylinder by bypassing orifice of each valve when brake is released.

COMPONENT PARTS

< SYSTEM DESCRIPTION >

[WITH VDC]

Reservoir

Temporarily reserves the brake fluid drained from brake caliper, so that pressure efficiently decreases when decreasing pressure of brake caliper.

A

Stop Lamp Switch

INFOID:000000009752887

B

Detects the operation status of brake pedal and transmits converted electric signal to ABS actuator and electric unit (control unit).

Brake Pedal Position Switch

INFOID:000000009752888

C

Detects the operation status of brake pedal and transmits converted electric signal to ABS actuator and electric unit (control unit).

D

Steering Angle Sensor

INFOID:000000009752889

Detects the following information and transmits steering angle signal to ABS actuator and electric unit (control unit) via CAN communication.

E

- Steering wheel rotation amount
- Steering wheel rotation angular velocity
- Steering wheel rotation direction

BRC

Yaw Rate/Side/Decel G Sensor

INFOID:000000009752890

Calculates the following information that affects the vehicle, and transmits a signal to ABS actuator and electric unit (control unit) via communication lines.

G

- Vehicle rotation angular velocity (yaw rate signal)
- Vehicle lateral acceleration (side G signal) and longitudinal acceleration (decel G signal)

H

VDC OFF Switch

INFOID:000000009752891

- This is an integrated switch with switches for other functions.
- Non-operational status or standby status of the following functions can be selected using VDC OFF switch. VDC OFF indicator lamp indicates the operation status of function. (ON: Non-operational status, OFF: Standby status)

I

- VDC function

J

NOTE:

- Brake limited slip differential (BLSD) function control operates.
- TCS function
- VDC OFF indicator lamp turns OFF (standby status) when the engine is started again after it is stopped once while VDC OFF indicator lamp is ON (non-operational status).

K

L

Brake Fluid Level Switch

INFOID:000000009752892

Detects the brake fluid level in reservoir tank and transmits converted electric signal from combination meter to ABS actuator and electric unit (control unit) via CAN communication, when brake fluid level is the specified level or less.

M

Parking Brake Switch

INFOID:000000009752893

N

Detects the operation status of parking brake switch and transmits converted electric signal from combination meter to ABS actuator and electric unit (control unit).

O

P

SYSTEM

System Description

INFOID:00000009752894

- The system switches fluid pressure of each brake caliper to increase, to hold or to decrease according to signals from control unit in ABS actuator and electric unit (control unit). This control system is applied to VDC function, TCS function, ABS function, EBD function and brake limited slip differential (BLSD) function.
- Fail-safe function is available for each function and is activated by each function when system malfunction occurs.

SYSTEM DIAGRAM

NOTE:

- TCM is CVT models only.
- AWD control module is AWD models only.

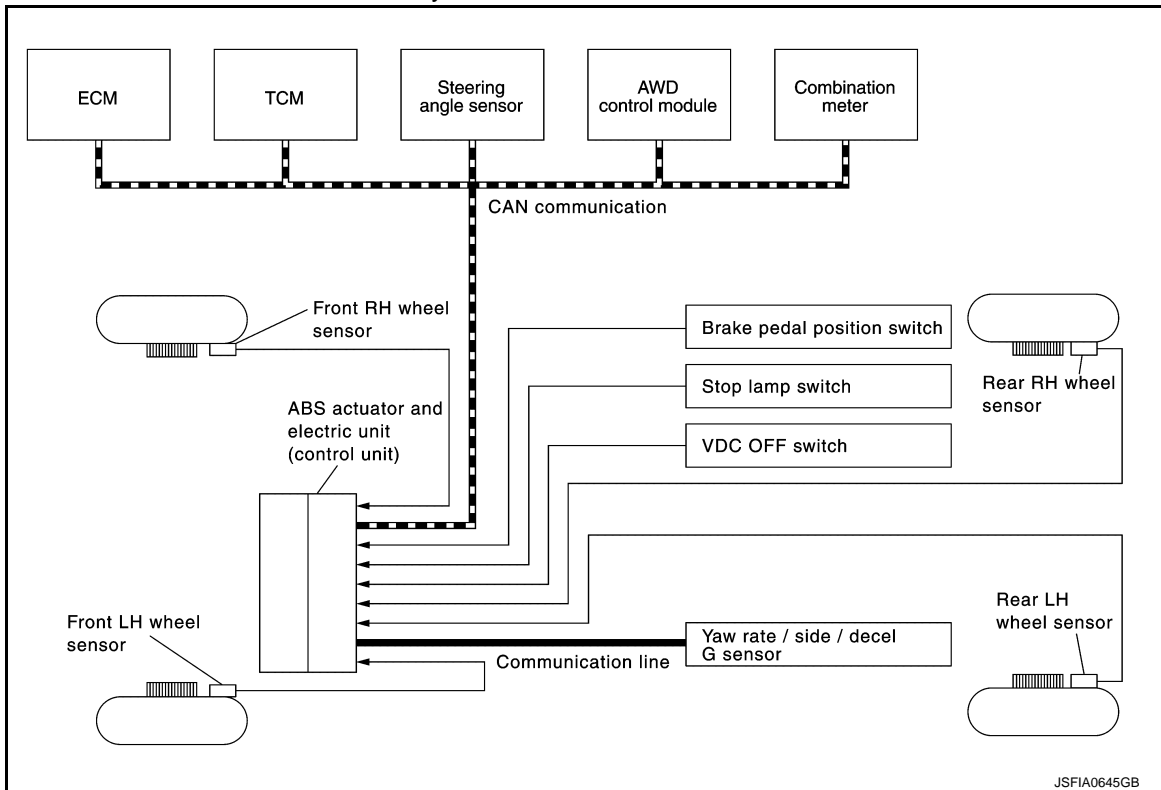

INPUT SIGNAL AND OUTPUT SIGNAL

Major signal transmission between each unit via communication lines is shown in the following table.

SYSTEM

[WITH VDC]

< SYSTEM DESCRIPTION >

VDC function, TCS function, ABS function, EBD function, Brake limited slip differential (BLSD) function

Component	Signal description
Steering angle sensor	Mainly transmits the following signals to ABS actuator and electric unit (control unit) via CAN communication. <ul style="list-style-type: none"> • Steering angle sensor signal
Yaw rate/side/decel G sensor	Mainly transmits the following signals to ABS actuator and electric unit (control unit) via communication line*1 <ul style="list-style-type: none"> • Yaw rate signal • Side G sensor signal • Decel G sensor signal
ECM	Mainly transmits the following signals to ABS actuator and electric unit (control unit) via CAN communication. <ul style="list-style-type: none"> • Accelerator pedal position signal • Engine speed signal Mainly receives the following signals from ABS actuator and electric unit (control unit) via CAN communication. <ul style="list-style-type: none"> • Target throttle position signal
TCM*2	Mainly transmits the following signals to ABS actuator and electric unit (control unit) via CAN communication. <ul style="list-style-type: none"> • N range signal • P range signal • R range signal • Current gear position signal
AWD control module*3	Mainly transmits the following signals to ABS actuator and electric unit (control unit) via CAN communication. <ul style="list-style-type: none"> • Current AWD mode signal
Combination meter	Mainly transmits the following signals to ABS actuator and electric unit (control unit) via CAN communication. <ul style="list-style-type: none"> • Brake fluid level switch signal Mainly receives the following signals from ABS actuator and electric unit (control unit) via CAN communication. <ul style="list-style-type: none"> • ABS warning lamp signal • Brake warning lamp signal • VDC warning lamp signal • VDC OFF indicator lamp signal

*1: Communication line between yaw rate/side/decel G sensor and ABS actuator and electric unit (control unit)

*2: Models with CVT

*3: AWD models

VALVE OPERATION [VDC FUNCTION, TCS FUNCTION AND BRAKE LIMITED SLIP DIFFERENTIAL (BLSD) FUNCTION]

The control unit built in the ABS actuator and electric unit (control unit) controls fluid pressure of the brake calipers, respectively, by operating each valve.

When VDC Function, TSC Function and Brake Limited Slip Differential (BLSD) Function is in Operation (During Pres-

A
B
C
D
E
BRC
G
H
I
J
K
L
M
N
O
P

SYSTEM

< SYSTEM DESCRIPTION >

[WITH VDC]

sure Increases)

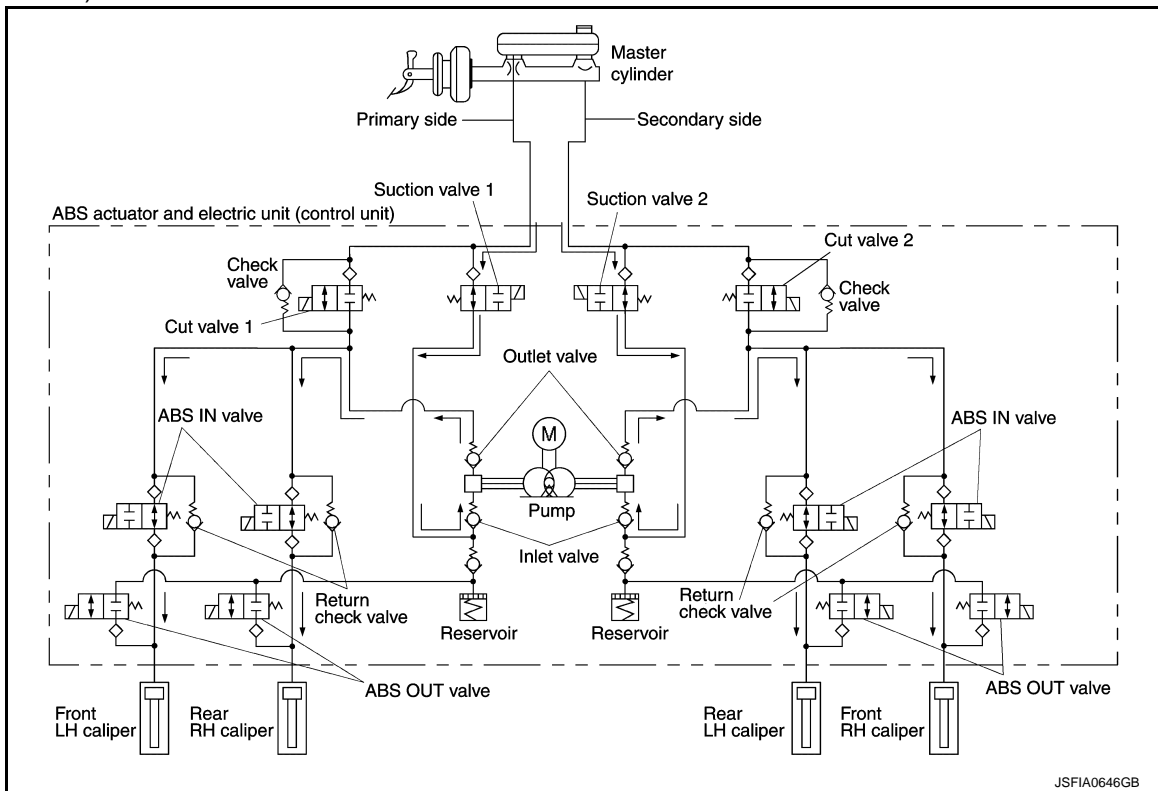

Name	Not activated	During pressure increases
Cut valve 1	Power supply is not supplied (open)	Power supply is supplied (close)
Cut valve 2	Power supply is not supplied (open)	Power supply is supplied (close)
Suction valve 1	Power supply is not supplied (close)	Power supply is supplied (open)
Suction valve 2	Power supply is not supplied (close)	Power supply is supplied (open)
ABS IN valve	Power supply is not supplied (open)	Power supply is not supplied (open)
ABS OUT valve	Power supply is not supplied (close)	Power supply is not supplied (close)
Each brake caliper (fluid pressure)	—	Pressure increases

During pressure front RH brake caliper increases

- Brake fluid is conveyed to the pump from the master cylinder through suction valve 2 and is pressurized by the pump operation. The pressurized brake fluid is supplied to the front RH brake caliper through the ABS IN valve. For the left caliper, brake fluid pressure is maintained because the pressurization is unnecessary. The pressurization for the left caliper is controlled separately from the right caliper.

During pressure front LH brake caliper increases

- Brake fluid is conveyed to the pump from the master cylinder through suction valve 1 and is pressurized by the pump operation. The pressurized brake fluid is supplied to the front LH brake caliper through the ABS IN valve. For the right caliper, brake fluid pressure is maintained because the pressurization is unnecessary. The pressurization for the right caliper is controlled separately from the left caliper.

During pressure rear RH brake caliper increases

- Brake fluid is conveyed to the pump from the master cylinder through suction valve 1 and is pressurized by the pump operation. The pressurized brake fluid is supplied to the rear RH brake caliper through the ABS IN valve. For the left caliper, brake fluid pressure is maintained because the pressurization is unnecessary. The pressurization for the left caliper is controlled separately from the right caliper.

During pressure rear LH brake caliper increases

- Brake fluid is conveyed to the pump from the master cylinder through suction valve 2 and is pressurized by the pump operation. The pressurized brake fluid is supplied to the rear LH brake caliper through the ABS IN

SYSTEM

[WITH VDC]

< SYSTEM DESCRIPTION >

valve. For the right caliper, brake fluid pressure is maintained because the pressurization is unnecessary. The pressurization for the right caliper is controlled separately from the left caliper.

When VDC Function, TSC Function and Brake Limited Slip Differential (BLSD) Function is Starts Operating (During Pressure Holds)

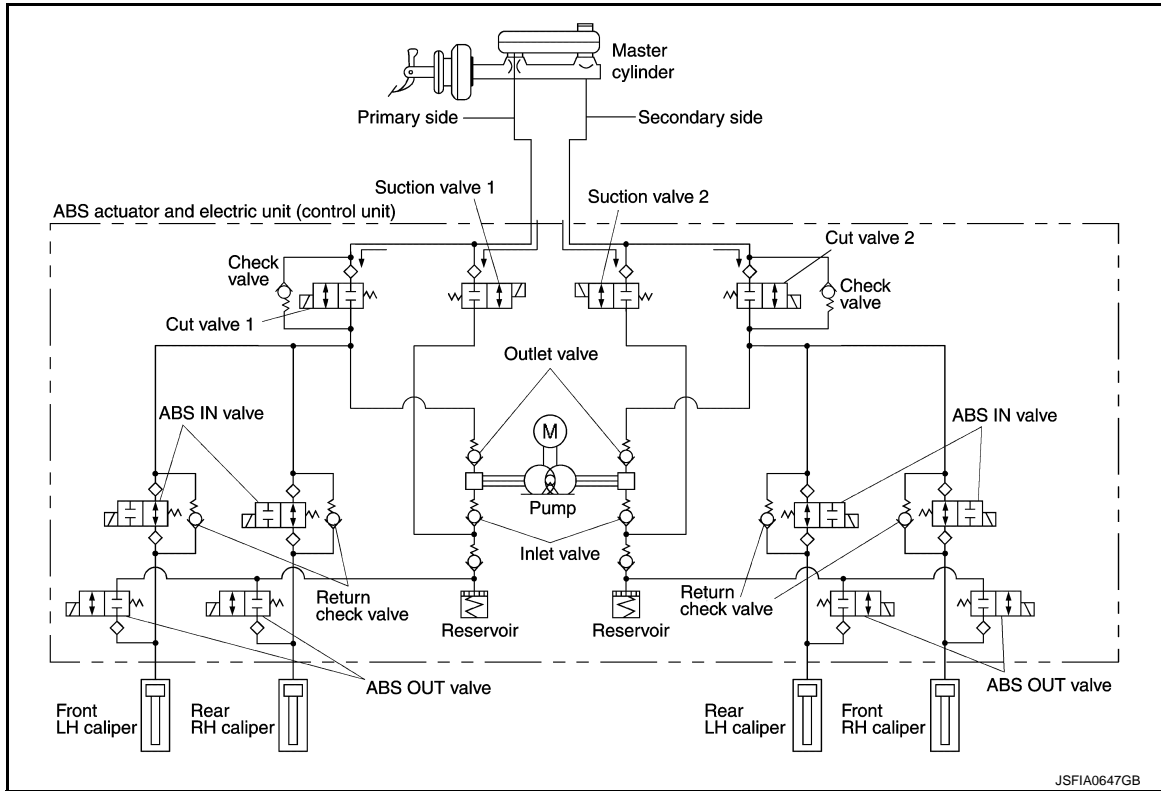

Name	Not activated	During pressure holds
Cut valve 1	Power supply is not supplied (open)	Power supply is supplied (close)
Cut valve 2	Power supply is not supplied (open)	Power supply is supplied (close)
Suction valve 1	Power supply is not supplied (close)	Power supply is not supplied (close)
Suction valve 2	Power supply is not supplied (close)	Power supply is not supplied (close)
ABS IN valve	Power supply is not supplied (open)	Power supply is not supplied (open)
ABS OUT valve	Power supply is not supplied (close)	Power supply is not supplied (close)
Each brake caliper (fluid pressure)	—	Pressure holds

During pressure front RH brake caliper holds

- Since the cut valve 2 and the suction valve 2 are closed, the front RH brake caliper, master cylinder, and reservoir are blocked. This maintains fluid pressure applied on the front RH brake caliper. The pressurization for the left caliper is controlled separately from the right caliper.

During pressure front LH brake caliper holds

- Since the cut valve 1 and the suction valve 1 are closed, the front LH brake caliper, master cylinder, and reservoir are blocked. This maintains fluid pressure applied on the front LH brake caliper. The pressurization for the right caliper is controlled separately from the left caliper.

During pressure rear RH brake caliper holds

- Since the cut valve 1 and the suction valve 1 are closed, the rear RH brake caliper, master cylinder, and reservoir are blocked. This maintains fluid pressure applied on the rear RH brake caliper. The pressurization for the left caliper is controlled separately from the right caliper.

During pressure rear LH brake caliper holds

SYSTEM

[WITH VDC]

< SYSTEM DESCRIPTION >

- Since the cut valve 2 and the suction valve 2 are closed, the rear LH brake caliper, master cylinder, and reservoir are blocked. This maintains fluid pressure applied on the rear LH brake caliper. The pressurization for the right caliper is controlled separately from the left caliper.

When VDC Function, TSC Function and Brake Limited Slip Differential (BLSD) Function is in Operation (During Pressure Decreases)

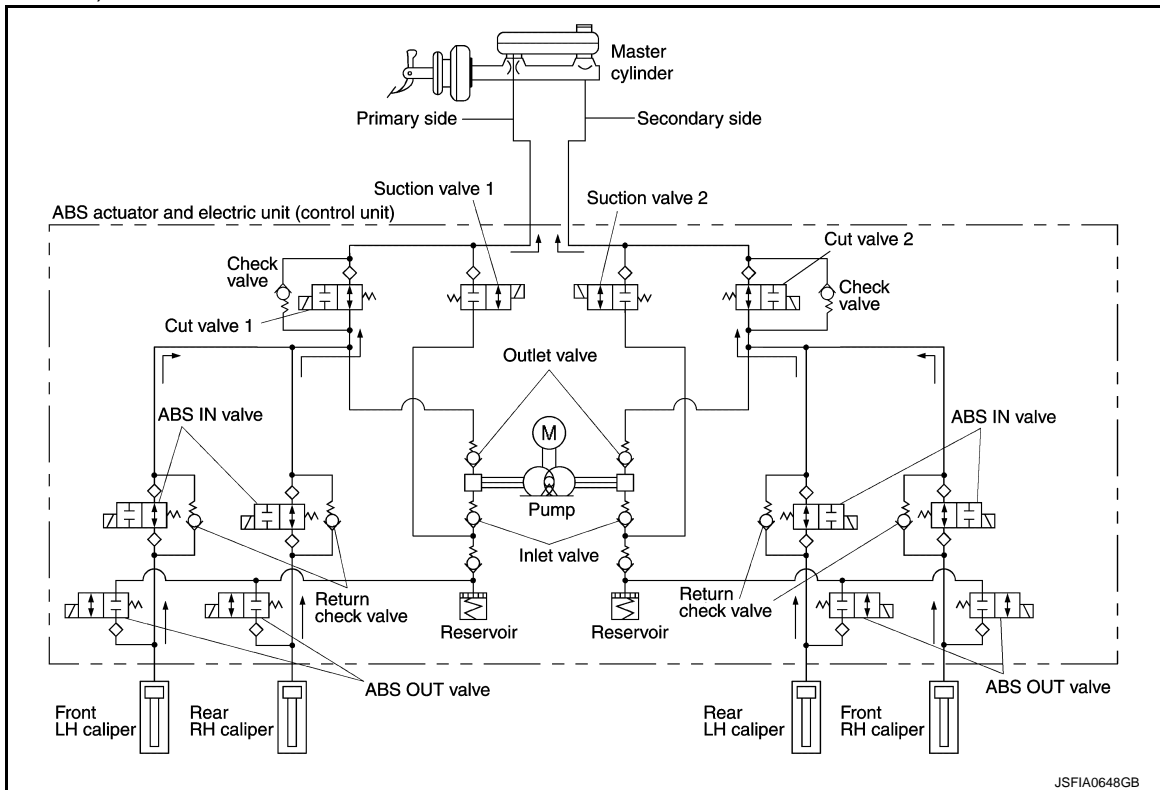

Name	Not activated	During pressure decreases
Cut valve 1	Power supply is not supplied (open)	Power supply is not supplied (open)
Cut valve 2	Power supply is not supplied (open)	Power supply is not supplied (open)
Suction valve 1	Power supply is not supplied (close)	Power supply is not supplied (close)
Suction valve 2	Power supply is not supplied (close)	Power supply is not supplied (close)
ABS IN valve	Power supply is not supplied (open)	Power supply is not supplied (open)
ABS OUT valve	Power supply is not supplied (close)	Power supply is not supplied (close)
Each brake caliper (fluid pressure)	—	Pressure decreases

During pressure front RH brake caliper decreases

- Since the suction valve 2 and the ABS OUT valve close and the cut valve 2 and the ABS IN valve open, the fluid pressure applied on the front RH brake caliper is reduced by supplying the fluid pressure to the master cylinder via the ABS IN valve and the cut valve 2. The pressurization for the right caliper is controlled separately from the left caliper.

During pressure front LH brake caliper decreases

- Since the suction valve 1 and the ABS OUT valve close and the cut valve 1 and the ABS IN valve open, the fluid pressure applied on the front LH brake caliper is reduced by supplying the fluid pressure to the master cylinder via the ABS IN valve and the cut valve 2. The pressurization for the left caliper is controlled separately from the right caliper.

During pressure rear RH brake caliper decreases

- Since the suction valve 1 and the ABS OUT valve close and the cut valve 1 and the ABS IN valve open, the fluid pressure applied on the rear RH brake caliper is reduced by supplying the fluid pressure to the master cylinder via the ABS IN valve and the cut valve 2. The pressurization for the right caliper is controlled separately from the left caliper.

SYSTEM

[WITH VDC]

< SYSTEM DESCRIPTION >

During pressure rear LH brake caliper decreases

- Since the suction valve 2 and the ABS OUT valve close and the cut valve 2 and the ABS IN valve open, the fluid pressure applied on the rear LH brake caliper is reduced by supplying the fluid pressure to the master cylinder via the ABS IN valve and the cut valve 2. The pressurization for the left caliper is controlled separately from the right caliper.

Component Parts and Function

Component	Function
Pump	Returns the brake fluid reserved in reservoir to master cylinder by reducing pressure.
Motor	Activates the pump according to signals from ABS actuator and electric unit (control unit).
Cut valve 1 Cut valve 2	Shuts off the ordinary brake line from master cylinder.
Suction valve 1 Suction valve 2	Supplies the brake fluid from master cylinder to the pump.
ABS IN valve	Switches the fluid pressure line to increase or hold according to signals from control unit.
ABS OUT valve	Switches the fluid pressure line to increase, hold or decrease according to signals from control unit.
Inlet valve	Brake fluid sucked from the reservoir by the pump does not backflow.
Outlet valve	Brake fluid discharged from the pump does not backflow.
Return check valve	Returns the brake fluid from brake caliper and wheel cylinder to master cylinder by bypassing orifice of each valve when brake is released.
Reservoir	Temporarily reserves the brake fluid drained from brake caliper, so that pressure efficiently decreases when decreasing pressure of brake caliper and wheel cylinder.

VALVE OPERATION (ABS FUNCTION AND EBD FUNCTION)

The control unit built in the ABS actuator and electric unit (control unit) controls fluid pressure of the brake calipers, respectively, by operating each valve.

When Brake Pedal is Applied or ABS Function is in Operation (During Pressure Increases)

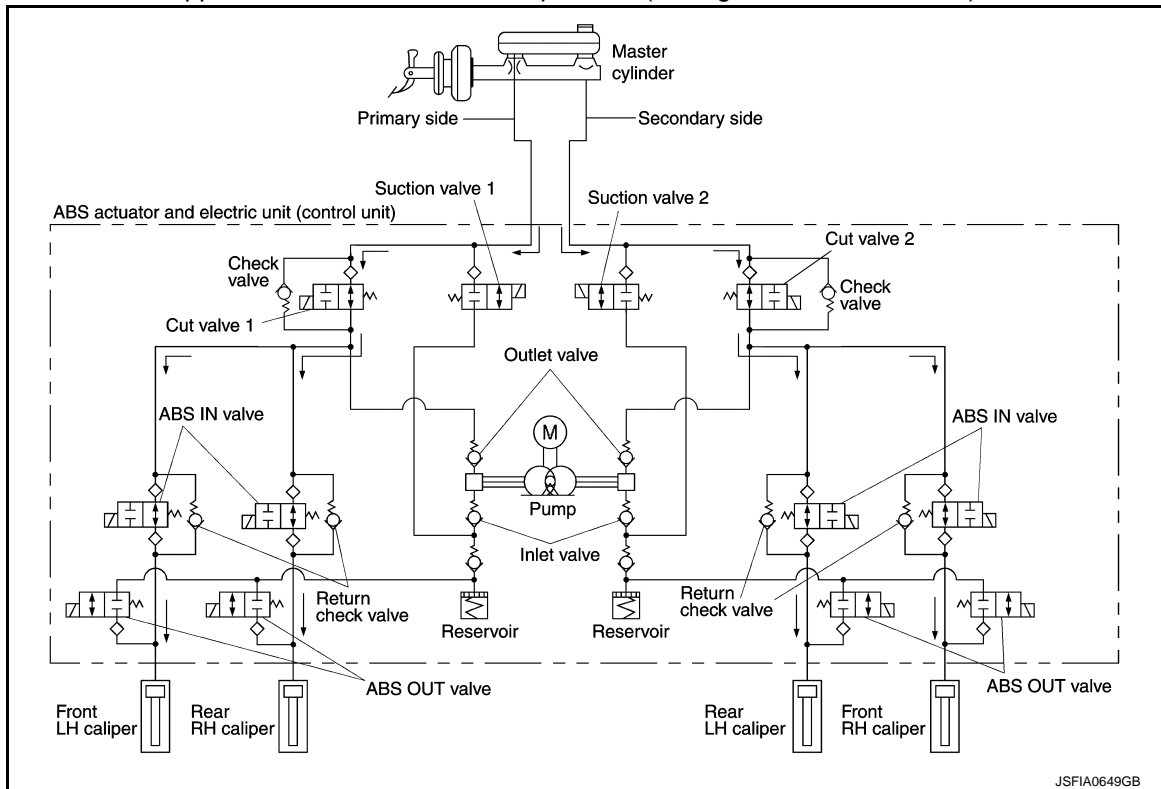

Name	Not activated	During pressure increases
Cut valve 1	Power supply is not supplied (open)	Power supply is not supplied (open)
Cut valve 2	Power supply is not supplied (open)	Power supply is not supplied (open)

SYSTEM

< SYSTEM DESCRIPTION >

[WITH VDC]

Name	Not activated	During pressure increases
Suction valve 1	Power supply is not supplied (close)	Power supply is not supplied (close)
Suction valve 2	Power supply is not supplied (close)	Power supply is not supplied (close)
ABS IN valve	Power supply is not supplied (open)	Power supply is not supplied (open)
ABS OUT valve	Power supply is not supplied (close)	Power supply is not supplied (close)
Each brake caliper (fluid pressure)	—	Pressure increases

During pressure front RH brake caliper increases

- When the cut valve 2 and the ABS IN valve opens, brake fluid is supplied to the front RH brake caliper from the master cylinder through the ABS IN valve. Brake fluid does not flow into the reservoir because the ABS OUT valve is closed.

During pressure front LH brake caliper increases

- When the cut valve 1 and the ABS IN valve opens, brake fluid is supplied to the front LH brake caliper from the master cylinder through the ABS IN valve. Brake fluid does not flow into the reservoir because the ABS OUT valve is closed.

During pressure rear RH brake caliper increases

- When the cut valve 1 and the ABS IN valve opens, brake fluid is supplied to the rear RH brake caliper from the master cylinder through the ABS IN valve. Brake fluid does not flow into the reservoir because the ABS OUT valve is closed.

During pressure rear LH brake caliper increases

- When the cut valve 2 and the ABS IN valve opens, brake fluid is supplied to the rear LH brake caliper from the master cylinder through the ABS IN valve. Brake fluid does not flow into the reservoir because the ABS OUT valve is closed.

When ABS Function is Starts Operating (During Pressure Holds)

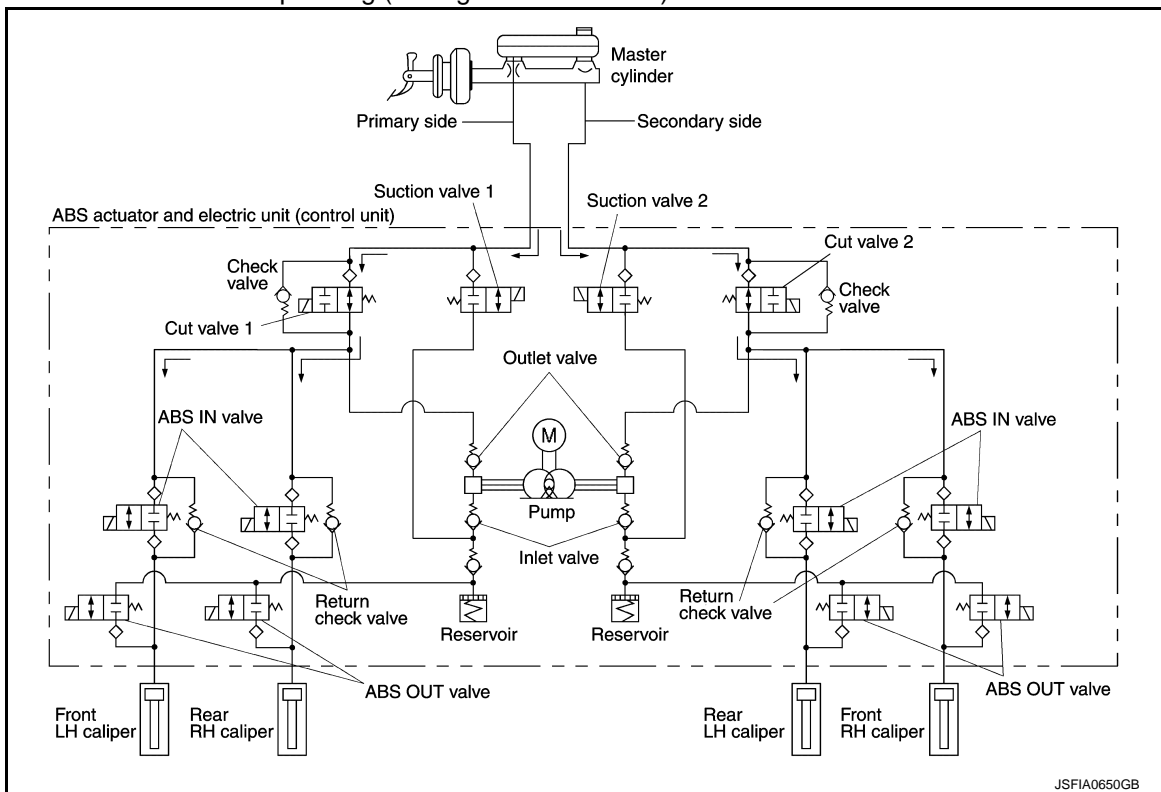

Name	Not activated	During pressure holds
Cut valve 1	Power supply is not supplied (open)	Power supply is not supplied (open)
Cut valve 2	Power supply is not supplied (open)	Power supply is not supplied (open)
Suction valve 1	Power supply is not supplied (close)	Power supply is not supplied (close)

SYSTEM

< SYSTEM DESCRIPTION >

[WITH VDC]

Name	Not activated	During pressure holds
Suction valve 2	Power supply is not supplied (close)	Power supply is not supplied (close)
ABS IN valve	Power supply is not supplied (open)	Power supply is supplied (close)
ABS OUT valve	Power supply is not supplied (close)	Power supply is not supplied (close)
Each brake caliper (fluid pressure)	—	Pressure holds

During pressure front RH brake caliper holds

- Since the ABS IN valve and the ABS OUT valve are closed, the front RH brake caliper, master cylinder, and reservoir are blocked. This maintains fluid pressure applied on the front RH brake caliper.

During pressure front LH brake caliper holds

- Since the ABS IN valve and the ABS OUT valve are closed, the front LH brake caliper, master cylinder, and reservoir are blocked. This maintains fluid pressure applied on the front LH brake caliper.

During pressure rear RH brake caliper holds

- Since the ABS IN valve and the ABS OUT valve are closed, the rear RH brake caliper, master cylinder, and reservoir are blocked. This maintains fluid pressure applied on the rear RH brake caliper.

During pressure rear LH brake caliper holds

- Since the ABS IN valve and the ABS OUT valve are closed, the rear LH brake caliper, master cylinder, and reservoir are blocked. This maintains fluid pressure applied on the rear LH brake caliper.

When ABS Function is in Operation (During Pressure Decreases)

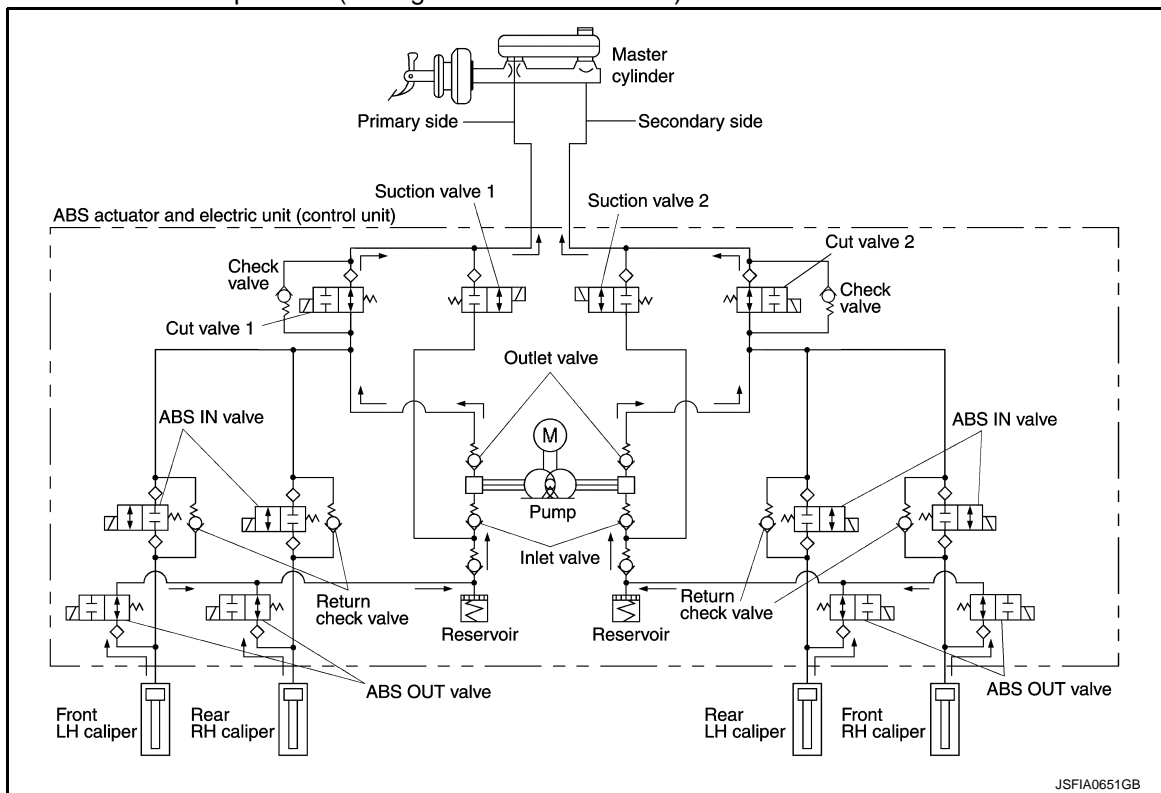

Name	Not activated	During pressure decreases
Cut valve 1	Power supply is not supplied (open)	Power supply is not supplied (open)
Cut valve 2	Power supply is not supplied (open)	Power supply is not supplied (open)
Suction valve 1	Power supply is not supplied (close)	Power supply is not supplied (close)
Suction valve 2	Power supply is not supplied (close)	Power supply is not supplied (close)
ABS IN valve	Power supply is not supplied (open)	Power supply is supplied (close)
ABS OUT valve	Power supply is not supplied (close)	Power supply is supplied (open)
Each brake caliper (fluid pressure)	—	Pressure decreases

SYSTEM

< SYSTEM DESCRIPTION >

[WITH VDC]

During pressure front RH brake caliper decreases

- Since the ABS IN valve is closed and the ABS OUT valve is opened, fluid pressure applied on the front RH brake caliper is supplied to the reservoir through the ABS OUT valve. This fluid pressure decreases when sent to the master cylinder by the pump.

During pressure front LH brake caliper decreases

- Since the ABS IN valve is closed and the ABS OUT valve is opened, fluid pressure applied on the front LH brake caliper is supplied to the reservoir through the ABS OUT valve. This fluid pressure decreases when sent to the master cylinder by the pump.

During pressure rear RH brake caliper decreases

- Since the ABS IN valve is closed and the ABS OUT valve is opened, fluid pressure applied on the rear RH brake caliper is supplied to the reservoir through the ABS OUT valve. This fluid pressure decreases when sent to the master cylinder by the pump.

During pressure rear LH brake caliper decreases

- Since the ABS IN valve is closed and the ABS OUT valve is opened, fluid pressure applied on the rear LH brake caliper is supplied to the reservoir through the ABS OUT valve. This fluid pressure decreases when sent to the master cylinder by the pump.

When ABS Function is in Operation (During Pressure Increases)

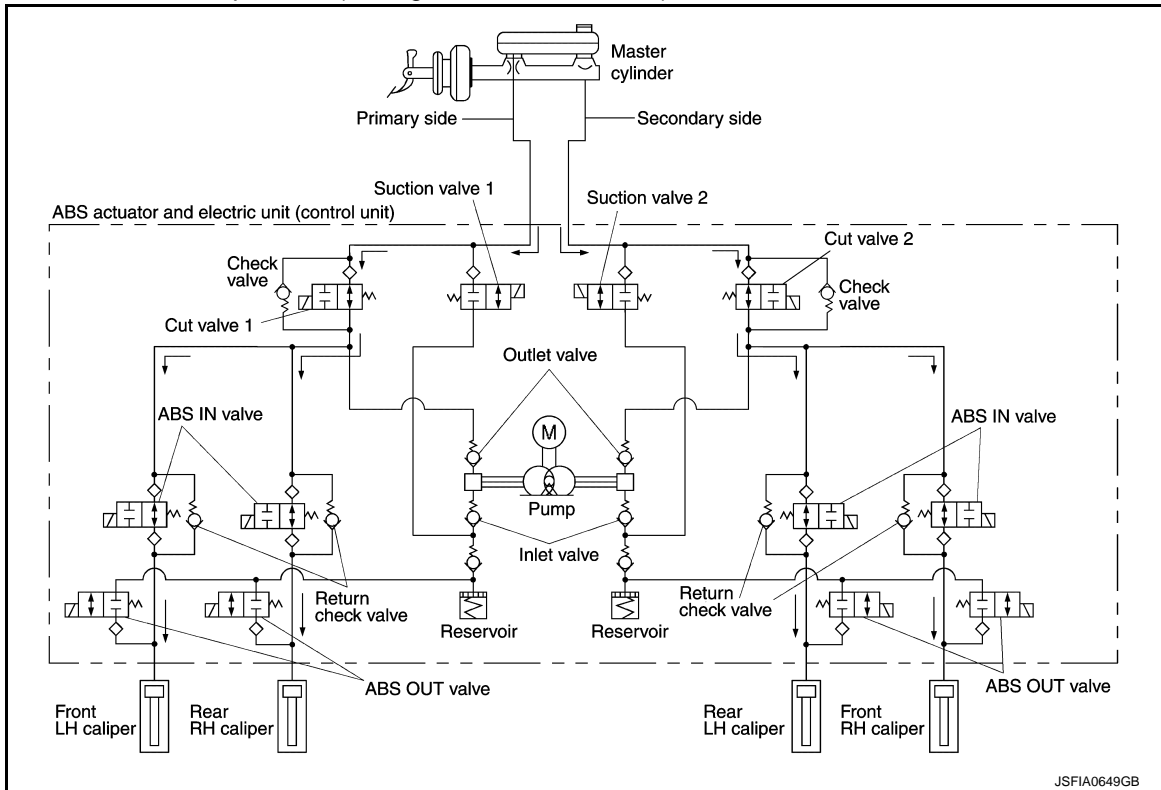

JSFIA0649GB

Name	Not activated	During pressure increases
Cut valve 1	Power supply is not supplied (open)	Power supply is not supplied (open)
Cut valve 2	Power supply is not supplied (open)	Power supply is not supplied (open)
Suction valve 1	Power supply is not supplied (close)	Power supply is not supplied (close)
Suction valve 2	Power supply is not supplied (close)	Power supply is not supplied (close)
ABS IN valve	Power supply is not supplied (open)	Power supply is not supplied (open)
ABS OUT valve	Power supply is not supplied (close)	Power supply is not supplied (close)
Each brake caliper (fluid pressure)	—	Pressure increases

During pressure front RH brake caliper increases

SYSTEM

[WITH VDC]

< SYSTEM DESCRIPTION >

- Brake fluid is supplied to the front RH brake caliper from the master cylinder through the cut valve 2 and the ABS IN valve. Since the suction valve 2 and the ABS OUT valve is closed, the fluid does not flow into the reservoir. The amount of brake fluid supplied to the front RH brake caliper from the master cylinder is controlled according to time that the ABS IN valve is not energized (time that the ABS IN valve is open).

During pressure front LH brake caliper increases

- Brake fluid is supplied to the front LH brake caliper from the master cylinder through the cut valve 1 and the ABS IN valve. Since the suction valve 1 and the ABS OUT valve is closed, the fluid does not flow into the reservoir. The amount of brake fluid supplied to the front LH brake caliper from the master cylinder is controlled according to time that the ABS IN valve is not energized (time that the ABS IN valve is open).

During pressure rear RH brake caliper increases

- Brake fluid is supplied to the rear RH brake caliper from the master cylinder through the cut valve 1 and the ABS IN valve. Since the suction valve 1 and the ABS OUT valve is closed, the fluid does not flow into the reservoir. The amount of brake fluid supplied to the rear RH brake caliper from the master cylinder is controlled according to time that the ABS IN valve is not energized (time that the ABS IN valve is open).

During pressure rear LH brake caliper increases

- Brake fluid is supplied to the rear LH brake caliper from the master cylinder through the cut valve 2 and the ABS IN valve. Since the suction valve 2 and the ABS OUT valve is closed, the fluid does not flow into the reservoir. The amount of brake fluid supplied to the rear LH brake caliper from the master cylinder is controlled according to time that the ABS IN valve is not energized (time that the ABS IN valve is open).

When Brake Release

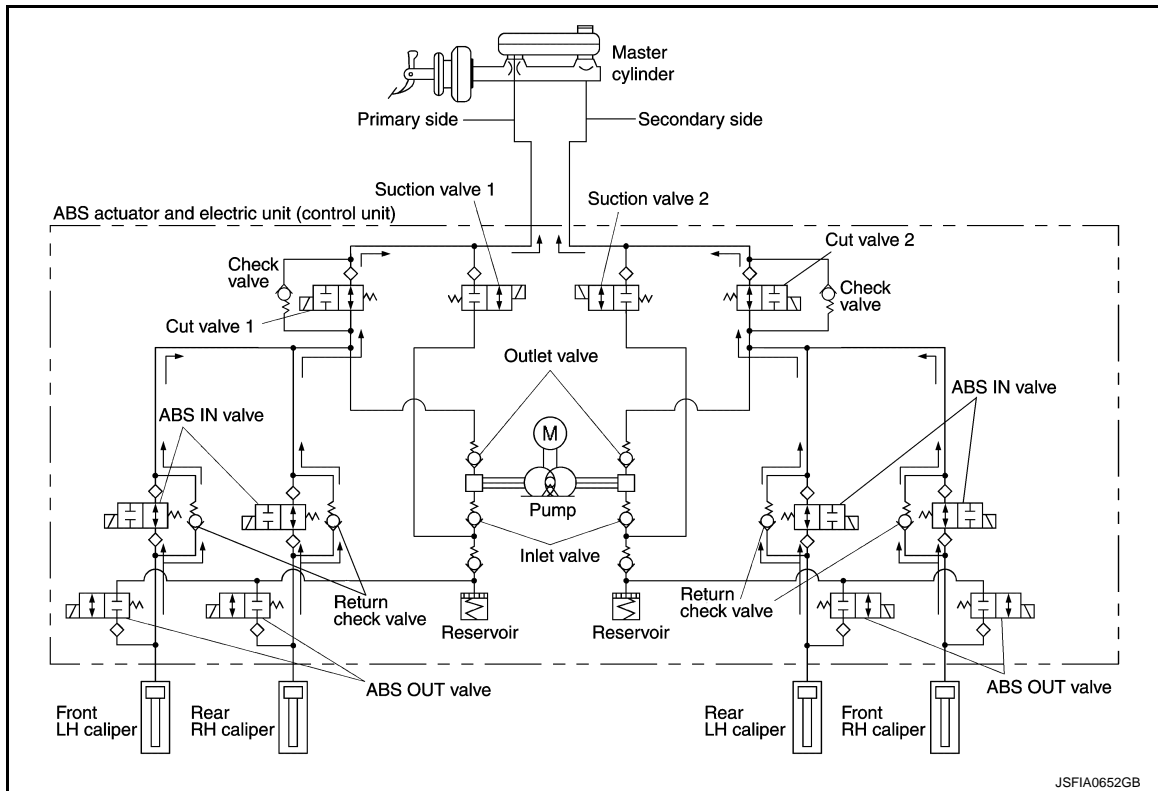

Name	Not activated	During brake release
Cut valve 1	Power supply is not supplied (open)	Power supply is not supplied (open)
Cut valve 2	Power supply is not supplied (open)	Power supply is not supplied (open)
Suction valve 1	Power supply is not supplied (close)	Power supply is not supplied (close)
Suction valve 2	Power supply is not supplied (close)	Power supply is not supplied (close)
ABS IN valve	Power supply is not supplied (open)	Power supply is not supplied (open)
ABS OUT valve	Power supply is not supplied (close)	Power supply is not supplied (close)
Each brake caliper (fluid pressure)	—	Pressure decreases

SYSTEM

[WITH VDC]

< SYSTEM DESCRIPTION >

During front RH brake caliper release

- Brake fluid is supplied to the front RH brake caliper through the return check valve of the ABS IN valve and the cut valve 2, and returns to the master cylinder.

During front LH brake caliper release

- Brake fluid is supplied to the front LH brake caliper through the return check valve of the ABS IN valve and the cut valve 1, and returns to the master cylinder.

During rear RH brake caliper release

- Brake fluid is supplied to the rear RH brake caliper through the return check valve of the ABS IN valve and the cut valve 1, and returns to the master cylinder.

During rear LH brake caliper release

- Brake fluid is supplied to the rear LH brake caliper through the return check valve of the ABS IN valve and the cut valve 2, and returns to the master cylinder.

Component Parts and Function

Component	Function
Pump	Returns the brake fluid reserved in reservoir to master cylinder by reducing pressure.
Motor	Activates the pump according to signals from ABS actuator and electric unit (control unit).
Cut valve 1 Cut valve 2	Shuts off the ordinary brake line from master cylinder.
Suction valve 1 Suction valve 2	Supplies the brake fluid from master cylinder to the pump.
ABS IN valve	Switches the fluid pressure line to increase or hold according to signals from control unit.
ABS OUT valve	Switches the fluid pressure line to increase, hold or decrease according to signals from control unit.
Inlet valve	Brake fluid sucked from the reservoir by the pump does not backflow.
Outlet valve	Brake fluid discharged from the pump does not backflow.
Return check valve	Returns the brake fluid from brake caliper and wheel cylinder to master cylinder by bypassing orifice of each valve when brake is released.
Reservoir	Temporarily reserves the brake fluid drained from brake caliper, so that pressure efficiently decreases when decreasing pressure of brake caliper and wheel cylinder.

CONDITION FOR TURN ON THE WARNING LAMP

Turns ON when ignition switch turns ON and turns OFF when the system is normal, for bulb check purposes.

Condition (status)	ABS warning lamp	Brake warning lamp	VDC warning lamp
Ignition switch OFF	OFF	OFF	OFF
For approx. 1 second after the ignition switch is turned ON	ON	ON	ON
Approx. 1 second after ignition switch is turned ON (when the system is in normal operation)	OFF	OFF	OFF
After engine starts	OFF	OFF	OFF
When parking brake operates (parking brake switch ON)	OFF	ON	OFF
When brake fluid is less than the specified level (brake fluid level switch ON)	OFF	ON	OFF
VDC function is malfunctioning	OFF	OFF	ON
TCS function is malfunctioning	OFF	OFF	ON
ABS function is malfunctioning	ON	OFF	ON
EBD function is malfunctioning	ON	ON	ON
Brake limited slip differential (BLSD) function is malfunctioning	OFF	OFF	ON
VDC function is operating	OFF	OFF	Blinking
TCS function is operating	OFF	OFF	Blinking

CONDITION FOR TURN ON THE INDICATOR LAMP

SYSTEM

[WITH VDC]

< SYSTEM DESCRIPTION >

- Turns ON when VDC function and TCS function are switched to non-operational status (OFF) by VDC OFF switch.
- Turns ON when ignition switch turns ON and turns OFF when the system is normal, for bulb check purposes.

Condition (status)	VDC OFF indicator lamp
Ignition switch OFF	OFF
For approx. 1 second after the ignition switch is turned ON	ON
Approx. 1 second after ignition switch is turned ON (when the system is in normal operation)	OFF
When VDC OFF switch is ON (VDC function and TCS function are OFF)	ON

Fail-safe

INFOID:000000009752895

VDC FUNCTION, TCS FUNCTION AND BRAKE LIMITED SLIP DIFFERENTIAL (BLSD) FUNCTION
VDC warning lamp in combination meter turn ON when a malfunction occurs in system [ABS actuator and electric unit (control unit)]. The control is suspended for VDC function, TCS function and brake limited slip differential (BLSD) function. The vehicle status becomes the same as models without VDC function, TCS function and brake limited slip differential (BLSD) function. However, ABS function and EBD function are operated normally.

ABS FUNCTION

ABS warning lamp and VDC warning lamp in combination meter turn ON when a malfunction occurs in system [ABS actuator and electric unit (control unit)]. The control is suspended for VDC function, TCS function, ABS function and brake limited slip differential (BLSD) function. The vehicle status becomes the same as models without VDC function, TCS function, ABS function and brake limited slip differential (BLSD) function. However, EBD function is operated normally.

NOTE:

ABS self-diagnosis sound may be heard the same as in the normal condition, because self-diagnosis is performed when ignition switch turns ON and when vehicle initially starts.

EBD FUNCTION

ABS warning lamp, brake warning lamp and VDC warning lamp in combination meter turn ON when a malfunction occurs in system [ABS actuator and electric unit (control unit)]. The control is suspended for VDC function, TCS function, ABS function, EBD function and brake limited slip differential (BLSD) function. The vehicle status becomes the same as models without VDC function, TCS function, ABS function, EBD function and brake limited slip differential (BLSD) function.

A
B
C
D
E
BRC
G
H
I
J
K
L
M
N
O
P

SYSTEM

< SYSTEM DESCRIPTION >

[WITH VDC]

DTC	Malfunction detected condition	Fail-safe condition	
C1101	When an open circuit is detected in rear RH wheel sensor circuit.	<p>The following functions are suspended.</p> <ul style="list-style-type: none"> • VDC function • TCS function • ABS function • EBD function (only when both 2 rear wheels are malfunctioning) • Brake limited slip differential (BLSD) function 	
C1102	When an open circuit is detected in rear LH wheel sensor circuit.		
C1103	When an open circuit is detected in front RH wheel sensor circuit.		
C1104	When an open circuit is detected in front LH wheel sensor circuit.		
C1105	<ul style="list-style-type: none"> • When a short circuit is detected in rear RH wheel sensor circuit. • When power supply voltage of rear RH wheel sensor is in following state. <ul style="list-style-type: none"> - Rear RH wheel sensor power supply voltage: $7.5\text{ V} \geq$ Rear RH wheel sensor power supply voltage - Rear RH wheel sensor power supply voltage: $16\text{ V} \leq$ Rear RH wheel sensor power supply voltage • When distance between rear RH wheel sensor and rear RH wheel sensor rotor is large. • When installation of rear RH wheel sensor or rear RH wheel sensor rotor is not normal. 		
C1106	<ul style="list-style-type: none"> • When a short circuit is detected in rear LH wheel sensor circuit. • When power supply voltage of rear LH wheel sensor is in following state. <ul style="list-style-type: none"> - Rear LH wheel sensor power supply voltage: $7.5\text{ V} \geq$ Rear LH wheel sensor power supply voltage - Rear LH wheel sensor power supply voltage: $16\text{ V} \leq$ Rear LH wheel sensor power supply voltage • When distance between rear LH wheel sensor and rear LH wheel sensor rotor is large. • When installation of rear LH wheel sensor or rear LH wheel sensor rotor is not normal. 		
C1107	<ul style="list-style-type: none"> • When a short circuit is detected in front RH wheel sensor circuit. • When power supply voltage of front RH wheel sensor is in following state. <ul style="list-style-type: none"> - Front RH wheel sensor power supply voltage: $7.5\text{ V} \geq$ Front RH wheel sensor power supply voltage - Front RH wheel sensor power supply voltage: $16\text{ V} \leq$ Front RH wheel sensor power supply voltage • When distance between front RH wheel sensor and front RH wheel sensor rotor is large. • When installation of front RH wheel sensor or front RH wheel sensor rotor is not normal. 		
C1108	<ul style="list-style-type: none"> • When a short circuit is detected in front LH wheel sensor circuit. • When power supply voltage of front LH wheel sensor is in following state. <ul style="list-style-type: none"> - Front LH wheel sensor power supply voltage: $7.5\text{ V} \geq$ Front LH wheel sensor power supply voltage - Front LH wheel sensor power supply voltage: $16\text{ V} \leq$ Front LH wheel sensor power supply voltage • When distance between front LH wheel sensor and front LH wheel sensor rotor is large. • When installation of front LH wheel sensor or front LH wheel sensor rotor is not normal. 		
C1109	<p>When ignition power supply voltage is in following state.</p> <ul style="list-style-type: none"> • Ignition power supply voltage: $10\text{ V} \geq$ Ignition power supply voltage. • Ignition power supply voltage: $16\text{ V} \leq$ Ignition power supply voltage. 		<p>The following functions are suspended.</p> <ul style="list-style-type: none"> • VDC function • TCS function • ABS function • EBD function • Brake limited slip differential (BLSD) function
C1110	When there is an internal malfunction in the ABS actuator and electric unit (control unit).		<p>The following functions are suspended.</p> <ul style="list-style-type: none"> • VDC function • TCS function • ABS function • EBD function • Brake limited slip differential (BLSD) function
C1111	When a malfunction is detected in motor or motor relay.		<p>The following functions are suspended.</p> <ul style="list-style-type: none"> • VDC function • TCS function • ABS function • Brake limited slip differential (BLSD) function

SYSTEM

< SYSTEM DESCRIPTION >

[WITH VDC]

DTC	Malfunction detected condition	Fail-safe condition	
C1113	When a malfunction is detected in decel G signal, or signal line of yaw rate/side/decel G sensor is open or shorted.	The following functions are suspended. <ul style="list-style-type: none"> • VDC function • TCS function • ABS function (AWD) • Brake limited slip differential (BLSD) function 	A B
C1115	When difference in wheel speed between any wheel and others is detected the vehicle is driven, because of installation of other tires than specified.	The following functions are suspended. <ul style="list-style-type: none"> • VDC function • TCS function • ABS function • EBD function • Brake limited slip differential (BLSD) function 	C D E
C1116	When stop lamp switch signal is not input when brake pedal operates.	The following functions are suspended. <ul style="list-style-type: none"> • VDC function • TCS function • Brake limited slip differential (BLSD) function 	BRC
C1120	When a malfunction is detected in front LH ABS IN valve.	The following functions are suspended. <ul style="list-style-type: none"> • VDC function • TCS function • ABS function • EBD function • Brake limited slip differential (BLSD) function 	G
C1121	When a malfunction is detected in front LH ABS OUT valve.		H
C1122	When a malfunction is detected in front RH ABS IN valve.		I
C1123	When a malfunction is detected in front RH ABS OUT valve.		J
C1124	When a malfunction is detected in rear LH ABS IN valve.		K
C1125	When a malfunction is detected in rear LH ABS OUT valve.		L
C1126	When a malfunction is detected in rear RH ABS IN valve.		M
C1127	When a malfunction is detected in rear RH ABS OUT valve.	N	
C1130	When a malfunction is detected in ECM system.	The following functions are suspended. <ul style="list-style-type: none"> • VDC function • TCS function • Brake limited slip differential (BLSD) function 	O
C1140	When a malfunction is detected in actuator relay.	The following functions are suspended. <ul style="list-style-type: none"> • VDC function • TCS function • ABS function • EBD function • Brake limited slip differential (BLSD) function 	P
C1143	When a malfunction is detected in steering angle sensor.	The following functions are suspended. <ul style="list-style-type: none"> • VDC function • TCS function • ABS function (AWD) • Brake limited slip differential (BLSD) function 	
C1144	When neutral position adjustment of steering angle sensor is not complete.	The following functions are suspended. <ul style="list-style-type: none"> • VDC function • TCS function • Brake limited slip differential (BLSD) function 	

SYSTEM

< SYSTEM DESCRIPTION >

[WITH VDC]

DTC	Malfunction detected condition	Fail-safe condition
C1145	When a malfunction is detected in yaw rate signal, or signal line of yaw rate/side/decel G sensor is open or shorted.	The following functions are suspended. <ul style="list-style-type: none"> • VDC function • TCS function • ABS function (AWD) • Brake limited slip differential (BLSD) function
C1146	When a malfunction is detected in side G signal, or signal line of yaw rate/side/decel G sensor is open or shorted.	
C1155	When brake fluid level low signal is detected.	The following functions are suspended. <ul style="list-style-type: none"> • VDC function • TCS function • Brake limited slip differential (BLSD) function
C1164	When a malfunction is detected in cut valve 1.	The following functions are suspended. <ul style="list-style-type: none"> • VDC function • TCS function • ABS function • EBD function • Brake limited slip differential (BLSD) function
C1165	When a malfunction is detected in cut valve 2.	
C1166	When a malfunction is detected in suction valve 1.	
C1167	When a malfunction is detected in suction valve 2.	
C1170	When the information in ABS actuator and electric unit (control unit) is not the same.	The following functions are suspended. <ul style="list-style-type: none"> • VDC function • TCS function • ABS function • Brake limited slip differential (BLSD) function
C1176	When brake pedal position switch signal is not input when brake pedal operates.	The following functions are suspended. <ul style="list-style-type: none"> • VDC function • TCS function • Brake limited slip differential (BLSD) function
U1000	When CAN communication signal is not continuously transmitted or received for 2 seconds or more.	The following functions are suspended. <ul style="list-style-type: none"> • VDC function • TCS function • Brake limited slip differential (BLSD) function
U1010	When detecting error during the initial diagnosis of CAN controller of ABS actuator and electric unit (control unit).	

VDC FUNCTION

VDC FUNCTION : System Description

INFOID:000000009752896

- Side slip or tail slip may occur while driving on a slippery road or intending an urgent evasive driving. VDC function detects side slip status using each sensor when side slip or tail slip is about to occur and improves vehicle stability by brake control and engine output control during driving.
- In addition to ABS function, EBD function and TCS function, target side slip amount is calculated according to steering operation amount from steering angle sensor. By comparing this information with vehicle side slip amount that is calculated from information from yaw rate/side/decel G sensor and wheel sensor, vehicle driv-

SYSTEM

< SYSTEM DESCRIPTION >

[WITH VDC]

ing conditions (conditions of understeer or oversteer) are judged and vehicle stability is improved by brake force control on all 4 wheels and engine output control.

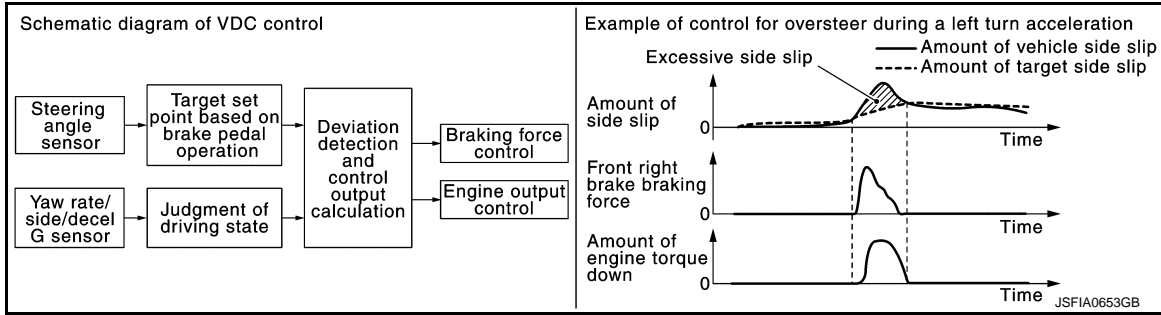

- VDC function can be switched to non-operational status (OFF) by operating VDC OFF switch. In this case, VDC OFF indicator lamp turns ON.
- Control unit portion automatically improves driving stability by performing brake force control as well as engine output control, by transmitting drive signal to actuator portion according to difference between target side slip amount and vehicle side slip amount
- VDC warning lamp blinks while VDC function is in operation and indicates to the driver that the function is in operation.
- CONSULT can be used to diagnose the system diagnosis.
- Fail-safe function is adopted. When a malfunction occurs in VDC function, the control is suspended for VDC function, TCS function and brake limited slip differential (BLSD) function. The vehicle status becomes the same as models without VDC function, TCS function and brake limited slip differential (BLSD) function. However, ABS function and EBD function are operated normally. Refer to [BRC-25, "Fail-safe"](#).

BRC

NOTE:

VDC has the characteristic as described here, This is not the device that helps reckless driving.

SYSTEM DIAGRAM

NOTE:

- TCM is CVT models only.
- AWD control module is AWD models only.

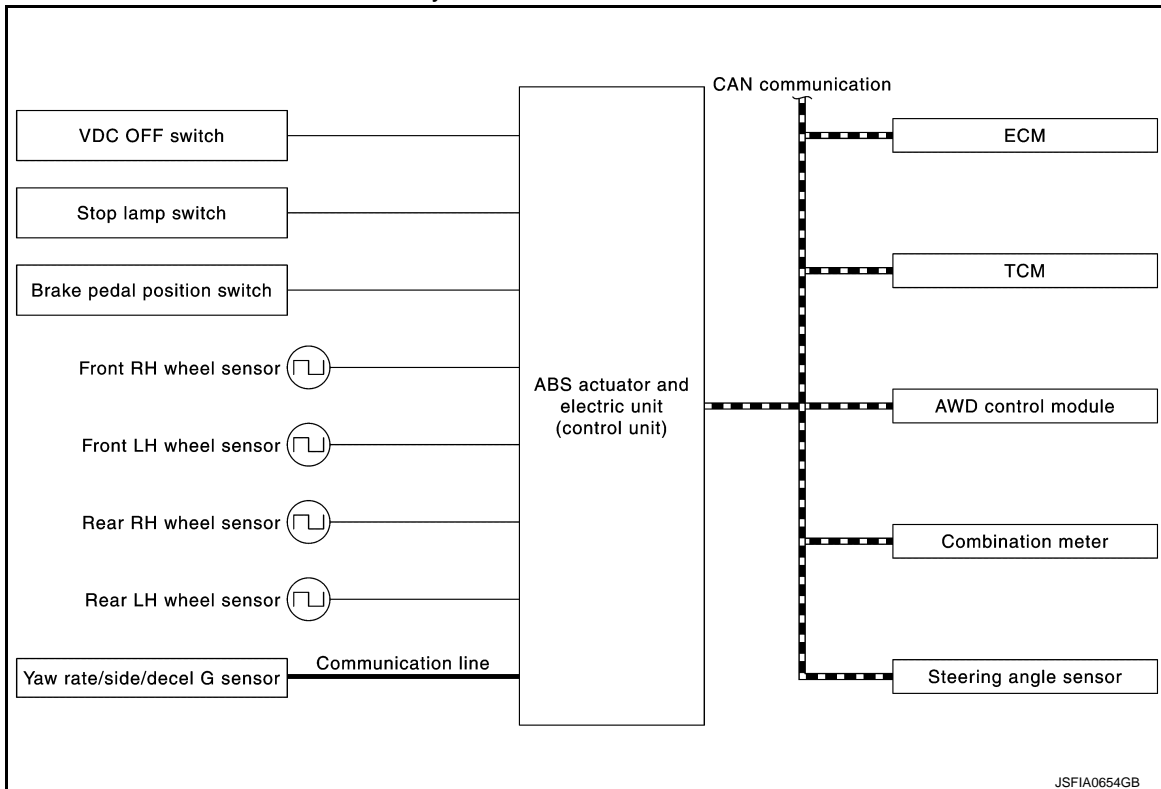

INPUT SIGNAL AND OUTPUT SIGNAL

Major signal transmission between each unit via communication lines is shown in the following table.

SYSTEM

< SYSTEM DESCRIPTION >

[WITH VDC]

Component	Signal description
Yaw rate/side/decel G sensor	Mainly transmits the following signals to ABS actuator and electric unit (control unit) via communication line*1. <ul style="list-style-type: none"> • Yaw rate signal • Side G sensor signal • Decel G sensor signal
ECM	Mainly transmits the following signals to ABS actuator and electric unit (control unit) via CAN communication. <ul style="list-style-type: none"> • Acceleration pedal position signal • Engine speed signal Mainly receives the following signals from ABS actuator and electric unit (control unit) via CAN communication. <ul style="list-style-type: none"> • Target throttle position signal
TCM*2	Mainly transmits the following signals to ABS actuator and electric unit (control unit) via CAN communication. <ul style="list-style-type: none"> • N range signal • P range signal • R range signal • Current gear position signal
AWD control module*3	Mainly transmits the following signals to ABS actuator and electric unit (control unit) via CAN communication. <ul style="list-style-type: none"> • Current AWD mode signal
Steering angle sensor	Mainly transmits the following signals to ABS actuator and electric unit (control unit) via CAN communication. <ul style="list-style-type: none"> • Steering angle sensor signal
Combination meter	Mainly transmits the following signals to ABS actuator and electric unit (control unit) via CAN communication. <ul style="list-style-type: none"> • Brake fluid level switch signal Mainly receives the following signals from ABS actuator and electric unit (control unit) via CAN communication. <ul style="list-style-type: none"> • VDC warning lamp signal • VDC OFF indicator lamp signal

*1: Communication line between yaw rate/side/decel G sensor and ABS actuator and electric unit (control unit)

*2: Models with CVT

*3: AWD models

OPERATION CHARACTERISTICS

VDC Function That Prevents Oversteer Tendency

- During a cornering, brake force (brake fluid pressure) is applied on front wheel and rear wheel on the outer side of turn. Moment directing towards the outer side of turn is generated. Oversteer is prevented.

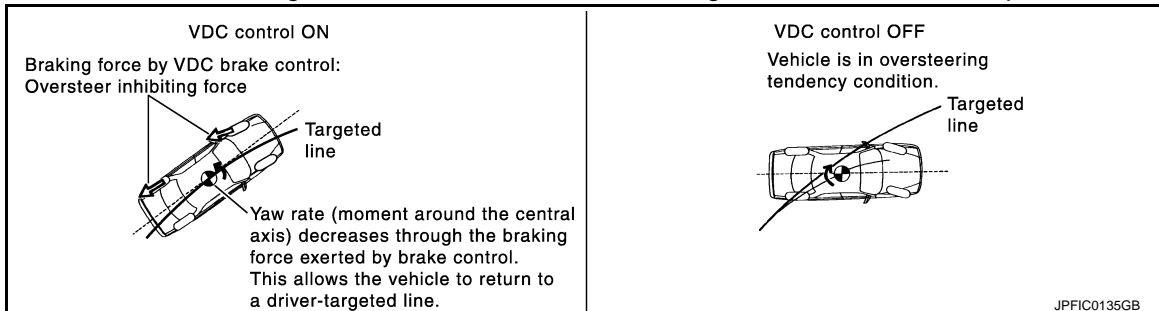

SYSTEM

< SYSTEM DESCRIPTION >

[WITH VDC]

- Changing driving lane on a slippery road, when oversteer tendency is judged large, engine output is controlled as well as brake force (brake fluid pressure) of 4 wheels. Oversteer tendency decreases.

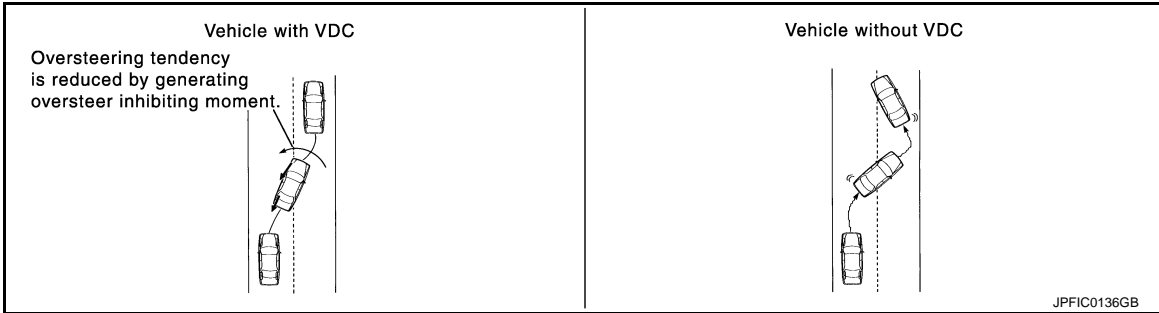

VDC Function That Prevents Understeer Tendency

- During a cornering, brake force (brake fluid pressure) is applied on front wheel and rear wheel on the inner side of turn. Moment directing towards the inner side of turn is generated. Understeer is prevented.

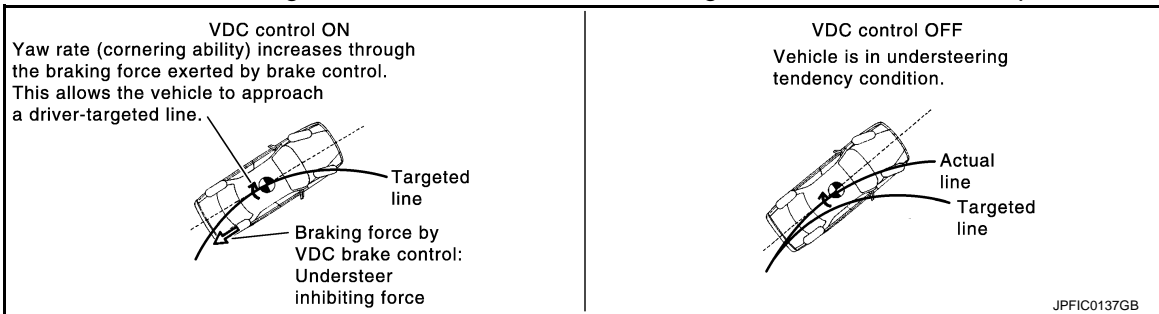

- Applying braking during a cornering on a slippery road, when understeer tendency is judged large, engine output is controlled as well as brake force (brake fluid pressure) of four wheels. Understeer tendency decreases.

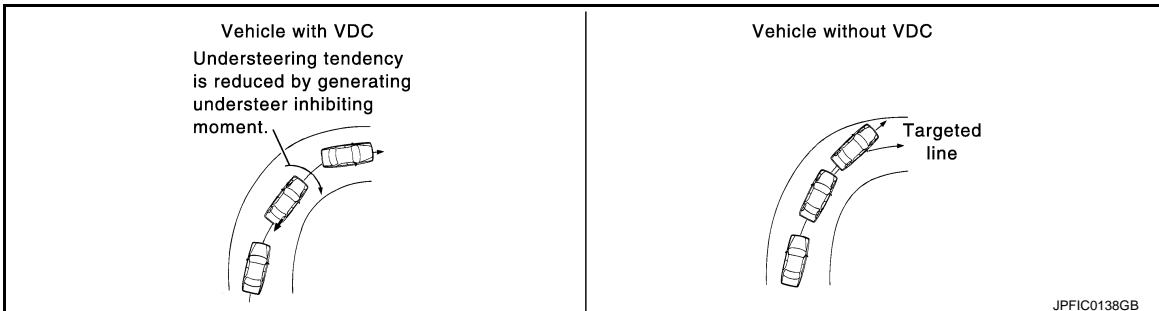

TCS FUNCTION

A
B
C
D
E
G
H
I
J
K
L
M
N
O
P

BRC

TCS FUNCTION : System Description

INFOID:00000009752897

- Wheel spin status of drive wheel is detected by wheel sensor of 4 wheels. Engine output and transmission shift status is controlled so that slip rate of drive wheels is in appropriate level. When wheel spin occurs on drive wheel, ABS actuator and electric unit (control unit) perform brake force control of LH and RH drive wheels (apply brake force by increasing brake fluid pressure of drive wheel) and decrease engine torque by engine torque control. Wheel spin amount decreases. Engine torque is controlled to appropriate level.
- TCS function can be switched to non-operational status (OFF) by operating VDC OFF switch. In this case, VDC OFF indicator lamp turns ON.
- VDC warning lamp blinks while TCS function is in operation and indicates to the driver that the function is in operation.
- CONSULT can be used to diagnose the system diagnosis.
- Fail-safe function is adopted. When a malfunction occurs in TCS function, the control is suspended for VDC function, TCS function and brake limited slip differential (BLSD) function. The vehicle status becomes the same as models without VDC function, TCS function and brake limited slip differential (BLSD) function. However, ABS function and EBD function are operated normally. Refer to [BRC-25, "Fail-safe"](#).

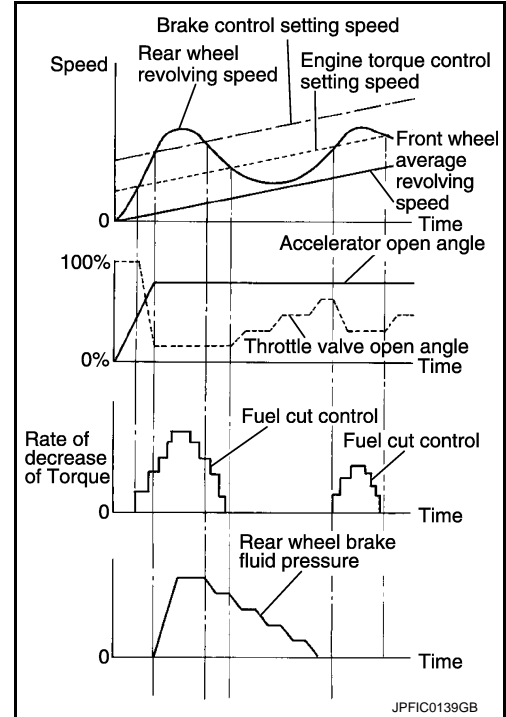

SYSTEM DIAGRAM

NOTE:

- TCM is CVT models only.
- AWD control module is AWD models only.

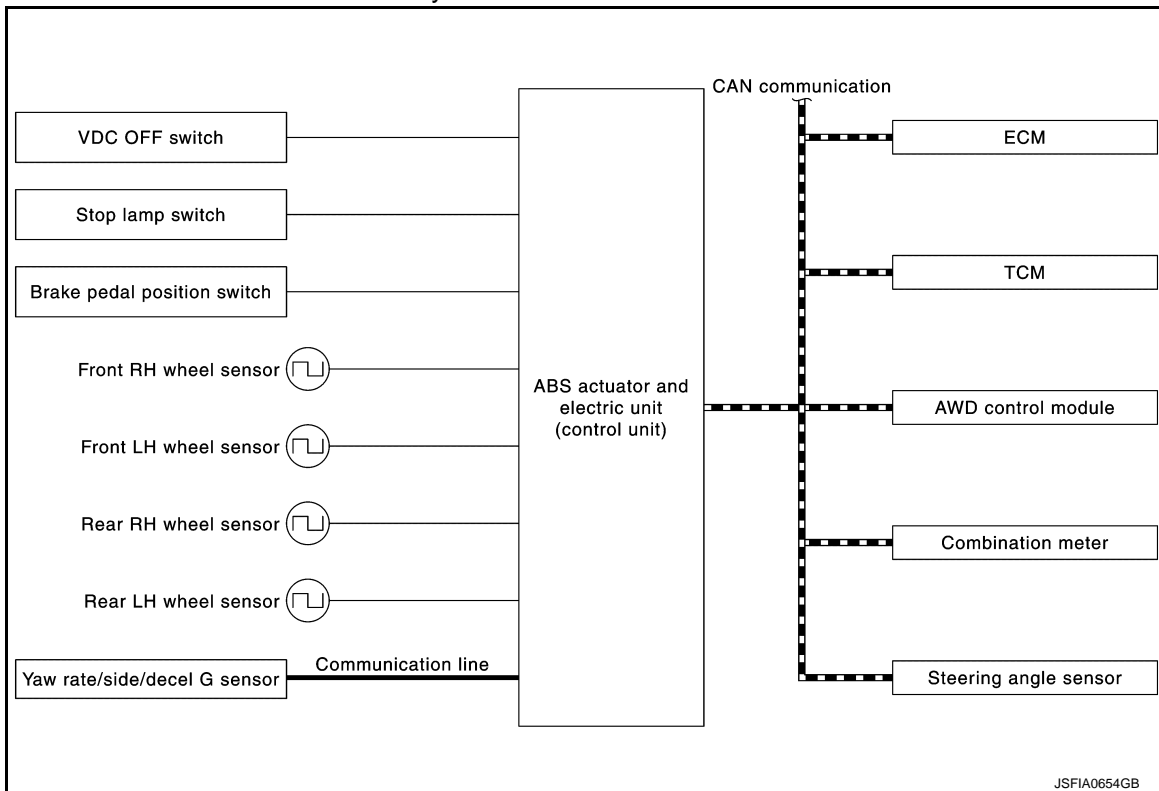

INPUT SIGNAL AND OUTPUT SIGNAL

Major signal transmission between each unit via communication lines is shown in the following table.

SYSTEM

< SYSTEM DESCRIPTION >

[WITH VDC]

Component	Signal description
Yaw rate/side/decel G sensor	Mainly transmits the following signals to ABS actuator and electric unit (control unit) via communication line*1. <ul style="list-style-type: none"> • Yaw rate signal • Side G sensor signal • Decel G sensor signal
ECM	Mainly transmits the following signals to ABS actuator and electric unit (control unit) via CAN communication. <ul style="list-style-type: none"> • Accelerator pedal position signal • Engine speed signal Mainly receives the following signals from ABS actuator and electric unit (control unit) via CAN communication. <ul style="list-style-type: none"> • Target throttle position signal
TCM*2	Mainly transmits the following signals to ABS actuator and electric unit (control unit) via CAN communication. <ul style="list-style-type: none"> • N range signal • P range signal • R range signal • Current gear position signal
AWD control module*3	Mainly transmits the following signals to ABS actuator and electric unit (control unit) via CAN communication. <ul style="list-style-type: none"> • Current AWD mode signal
Steering angle sensor	Mainly transmits the following signals to ABS actuator and electric unit (control unit) via CAN communication. <ul style="list-style-type: none"> • Steering angle sensor signal
Combination meter	Mainly transmits the following signals to ABS actuator and electric unit (control unit) via CAN communication. <ul style="list-style-type: none"> • Brake fluid level switch signal Mainly receives the following signals from ABS actuator and electric unit (control unit) via CAN communication. <ul style="list-style-type: none"> • VDC warning lamp signal • VDC OFF indicator lamp signal

*1: Communication line between yaw rate/side/decel G sensor and ABS actuator and electric unit (control unit)

*2: Models with CVT

*3: AWD models

ABS FUNCTION

ABS FUNCTION : System Description

INFOID:000000009752898

- By preventing wheel lock through brake force (brake fluid pressure) control that is electronically controlled by detecting wheel speed during braking, stability during emergency braking is improved so that obstacles can be easily bypassed by steering operation.
- During braking, control units calculates wheel speed and pseudo-vehicle speed, and transmits pressure increase, hold or decrease signals to actuator portion according to wheel slip status.

SYSTEM

[WITH VDC]

< SYSTEM DESCRIPTION >

- The following effects are obtained by preventing wheel lock during braking.
 - Vehicle tail slip is prevented during braking when driving straight.
 - Understeer and oversteer tendencies are moderated during braking driving on a corner.
 - Obstacles may be easily bypassed by steering operation during braking.
- CONSULT can be used to diagnose the system diagnosis.
- Fail-safe function is adopted. When a malfunction occurs in ABS function, the control is suspended for VDC function, TCS function, ABS function and brake limited slip differential (BLSD) function. The vehicle status becomes the same as models without VDC function, TCS function, ABS function and brake limited slip differential (BLSD) function. However, EBD function is operated normally. Refer to [BRC-25, "Fail-safe"](#).

NOTE:

- ABS has the characteristic as described here, but it is not the device that helps reckless driving.
- To stop vehicle efficiently, ABS does not operate and ordinary brake operates at low speed [approx. 10 km/h (6.2 MPH) or less, but differs subject to road conditions).
- Self-diagnosis is performed immediately after when engine starts and when vehicle initially is driven [by vehicle speed approx. 15 km/h (9.3 MPH)]. Motor sounds are generated during self-diagnosis. In addition, brake pedal may be felt heavy when depressing brake pedal lightly. These symptoms are not malfunctions.

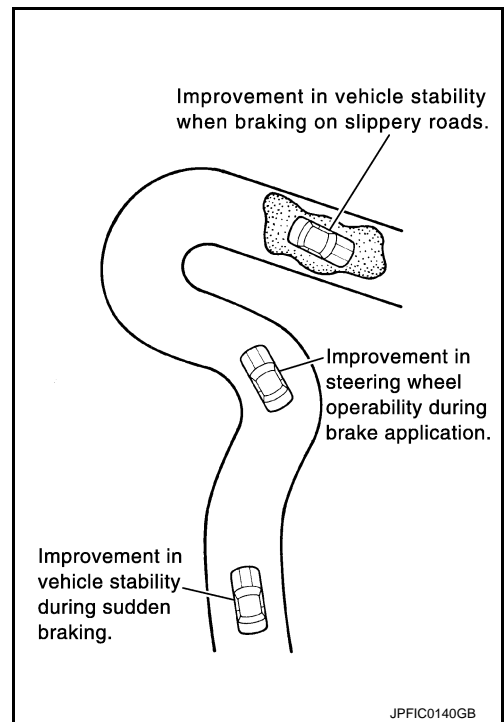

JPFIC0140GB

SYSTEM DIAGRAM

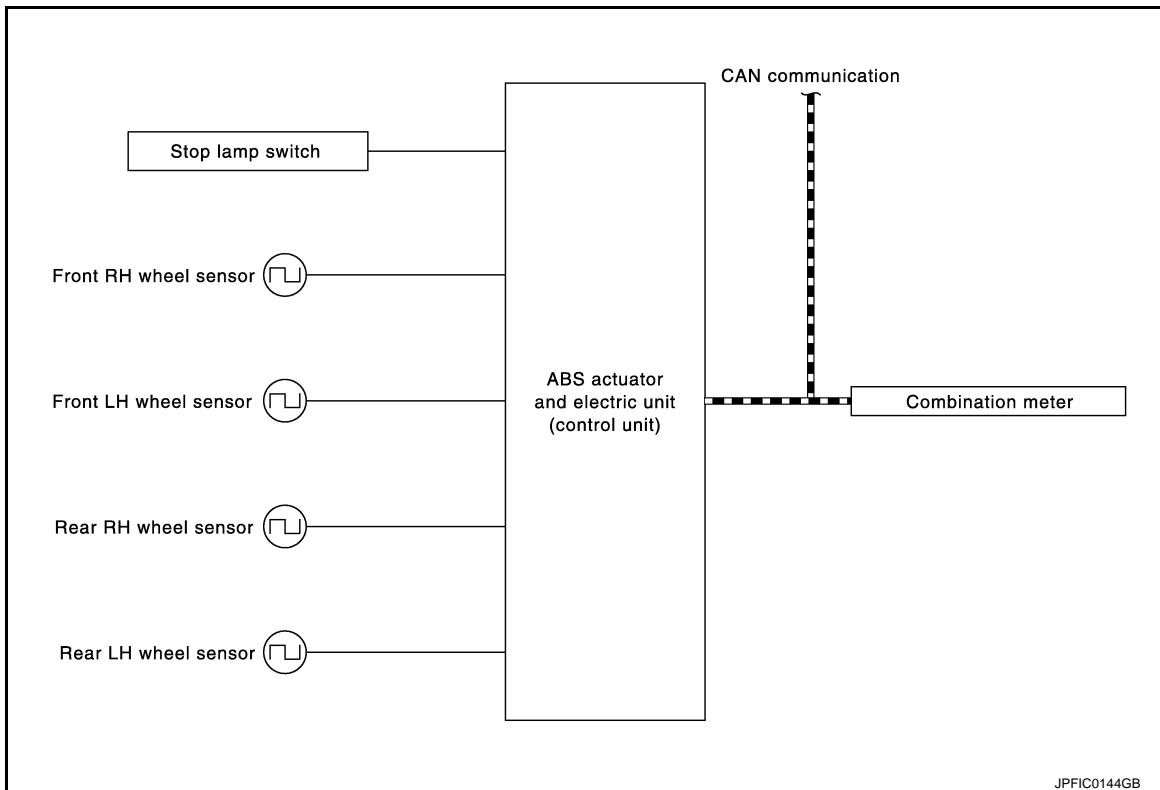

JPFIC0144GB

INPUT SIGNAL AND OUTPUT SIGNAL

Major signal transmission between each unit via communication lines is shown in the following table.

Component	Signal description
Combination meter	Mainly receives the following signals from ABS actuator and electric unit (control unit) via CAN communication. <ul style="list-style-type: none"> • VDC warning lamp signal • ABS warning lamp signal

EBD FUNCTION

EBD FUNCTION : System Description

INFOID:000000009752899

- By preventing rear wheel slip increase through rear wheel brake force (brake fluid pressure) control that is electronically controlled when slight skip on front and rear wheels are detected during braking, stability during braking is improved.
- EBD function is expanded and developed from conventional ABS function and corrects rear wheel brake force to appropriate level by electronic control according to load weight (number of passengers).

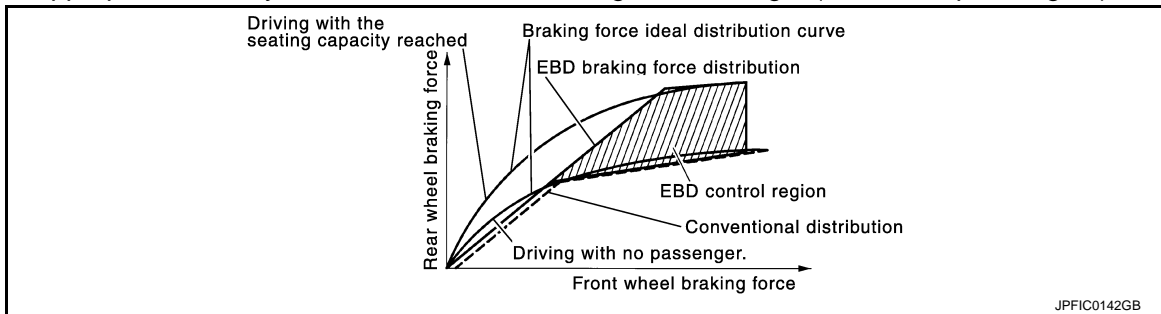

- During braking, control unit portion compares slight slip on front and rear wheels by wheel speed sensor signal, transmits drive signal to actuator portion when rear wheel slip exceeds front wheel slip for the specified value or more, and controls rear wheel brake force (brake fluid pressure) so that increase of rear wheel slip is prevented and slips on front wheel and rear wheel are nearly equalized. ABS control is applied when slip on each wheel increases and wheel speed is the threshold value of ABS control or less.
- CONSULT can be used to diagnose the system diagnosis.
- Fail-safe function is adopted. When a malfunction occurs in EBD function, the control is suspended for VDC function, TCS function, ABS function, EBD function and brake limited slip differential (BLSD) function. The vehicle status becomes the same as models without VDC function, TCS function, ABS function, EBD function and brake limited slip differential (BLSD) function. Refer to [BRC-25. "Fail-safe"](#).

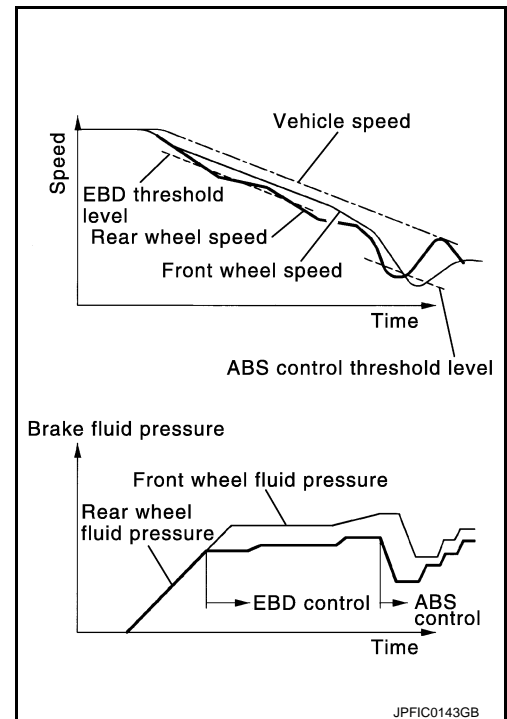

SYSTEM DIAGRAM

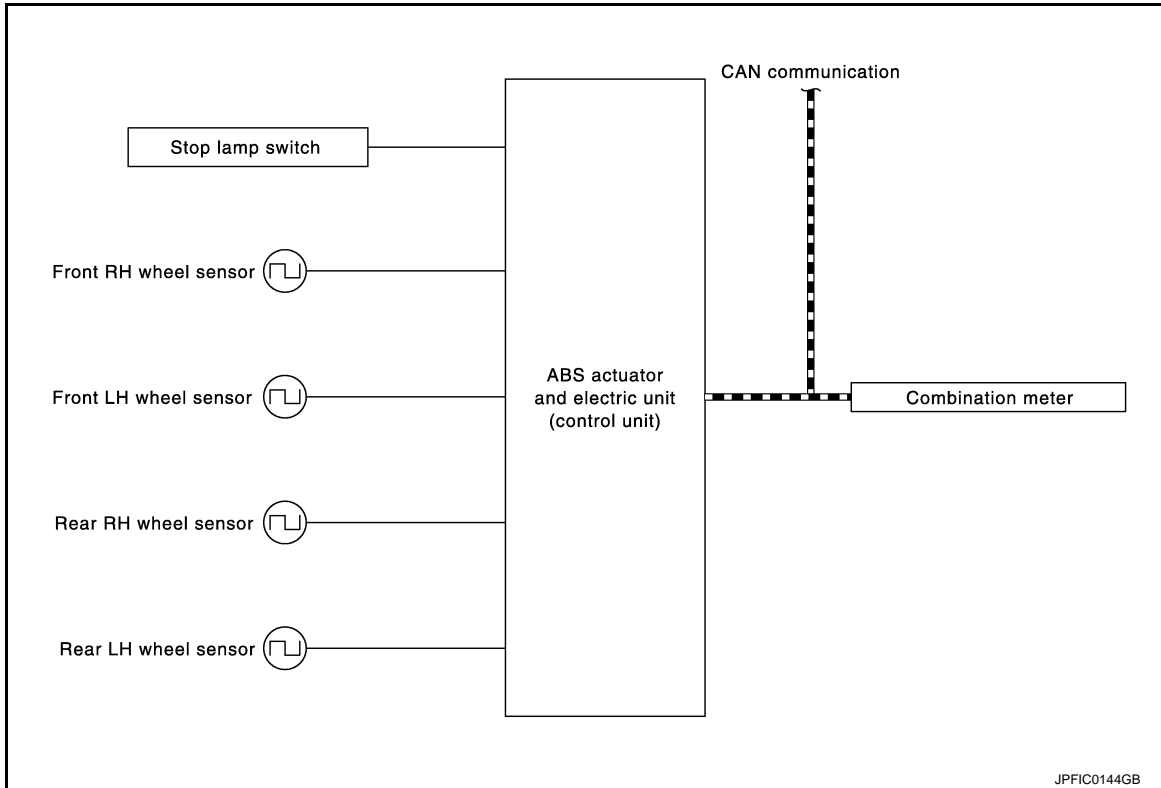

INPUT SIGNAL AND OUTPUT SIGNAL

Major signal transmission between each unit via communication lines is shown in the following table.

Component	Signal description
Combination meter	<p>Mainly receives the following signals from ABS actuator and electric unit (control unit) via CAN communication.</p> <ul style="list-style-type: none"> • VDC warning lamp signal • ABS warning lamp signal • Brake warning lamp signal

BRAKE LIMITED SLIP DIFFERENTIAL (BLSD) FUNCTION

BRAKE LIMITED SLIP DIFFERENTIAL (BLSD) FUNCTION : System Description

INFOID:000000009752900

- LH and RH driving wheel spin is always monitored. If necessary, appropriate brake force is independently applied to LH or RH driving wheel so that one-sided wheel spin is avoided and traction is maintained. Mainly starting ability is improved.
- Brake limited slip differential (BLSD) function operates while VDC function is in non-operational status (OFF) by VDC OFF switch.
- VDC warning lamp blinking while brake limited slip differential (BLSD) function is in operation and indicates to the driver that the function is in operation.
- Slight vibrations are felt on the brake pedal and the operation noises occur, when brake limited slip differential (BLSD) function operates. This is not a malfunction because it is caused by brake limited slip differential (BLSD) function that is normally operated.
- Fail-safe function is adopted. When a malfunction occurs in brake limited slip differential (BLSD) function, the control is suspended for VDC function, TCS function and brake limited slip differential (BLSD) function. The vehicle status becomes the same as models without VDC function, TCS function and brake limited slip differential (BLSD) function. However, ABS function and EBD function are operated normally. Refer to [BRC-25, "Fail-safe"](#).

SYSTEM DIAGRAM

NOTE:

- TCM is CVT models only.

SYSTEM

[WITH VDC]

< SYSTEM DESCRIPTION >

- AWD control module is AWD models only.

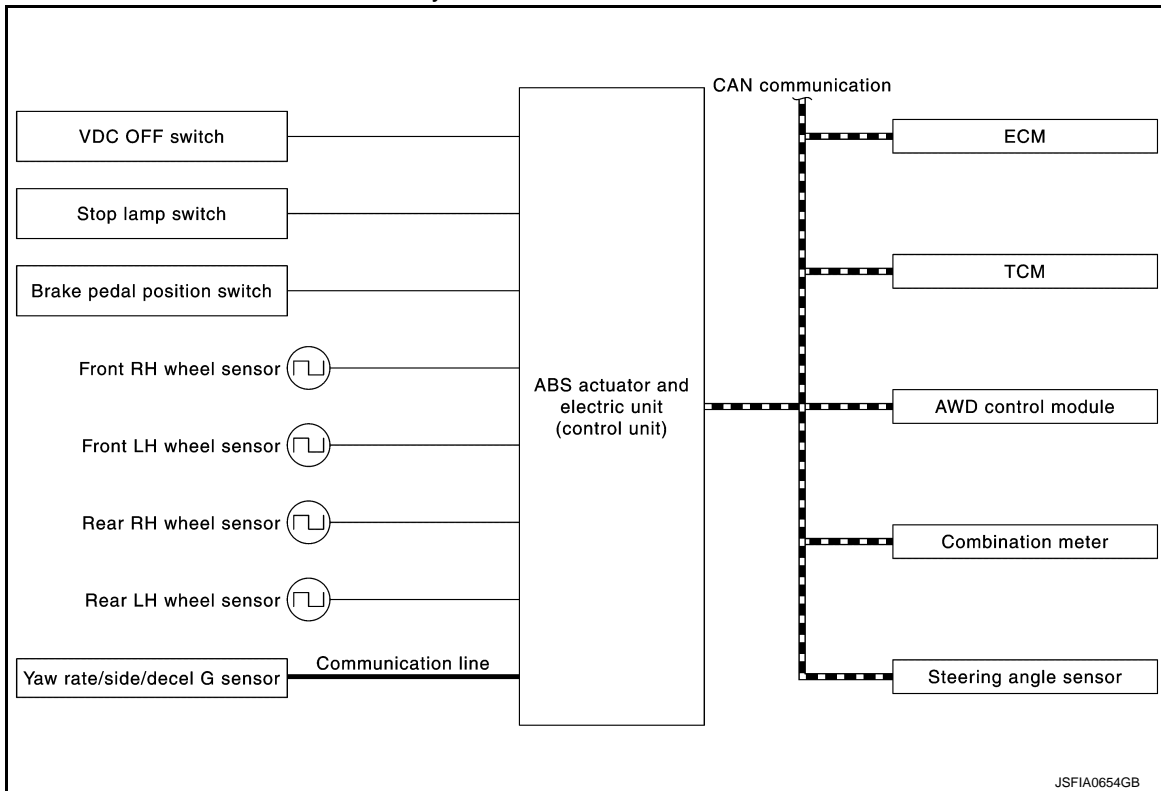

INPUT SIGNAL AND OUTPUT SIGNAL

Major signal transmission between each unit via communication lines is shown in the following table.

Component	Signal description
Yaw rate/side/decel G sensor	Mainly transmits the following signals to ABS actuator and electric unit (control unit) via communication line*1. <ul style="list-style-type: none"> • Yaw rate signal • Side G sensor signal • Decel G sensor signal
ECM	Mainly transmits the following signals to ABS actuator and electric unit (control unit) via CAN communication. <ul style="list-style-type: none"> • Accelerator pedal position signal • Engine speed signal Mainly receives the following signals from ABS actuator and electric unit (control unit) via CAN communication. <ul style="list-style-type: none"> • Target throttle position signal
TCM*2	Mainly transmits the following signals to ABS actuator and electric unit (control unit) via CAN communication. <ul style="list-style-type: none"> • N range signal • P range signal • R range signal • Current gear position signal
AWD control module*3	Mainly transmits the following signals to ABS actuator and electric unit (control unit) via CAN communication. <ul style="list-style-type: none"> • Current AWD mode signal

SYSTEM

< SYSTEM DESCRIPTION >

[WITH VDC]

Component	Signal description
Steering angle sensor	Mainly transmits the following signals to ABS actuator and electric unit (control unit) via CAN communication. <ul style="list-style-type: none">• Steering angle sensor signal
Combination meter	Mainly transmits the following signals to ABS actuator and electric unit (control unit) via CAN communication. <ul style="list-style-type: none">• Brake fluid level switch signal Mainly receives the following signals from ABS actuator and electric unit (control unit) via CAN communication. <ul style="list-style-type: none">• VDC warning lamp signal

*1: Communication line between yaw rate/side/decal G sensor and ABS actuator and electric unit (control unit)

*2: Models with CVT

*3: AWD models

DIAGNOSIS SYSTEM [ABS ACTUATOR AND ELECTRIC UNIT (CONTROL UNIT)]

< SYSTEM DESCRIPTION >

[WITH VDC]

DIAGNOSIS SYSTEM [ABS ACTUATOR AND ELECTRIC UNIT (CONTROL UNIT)]

CONSULT Function

INFOID:000000009752901

APPLICATION ITEMS

CONSULT can display each diagnostic item using the diagnostic test modes as follows.

Mode	Function description
ECU identification	Parts number of ABS actuator and electric unit (control unit) can be read.
Self Diagnostic Result	Self-diagnostic results and freeze frame data can be read and erased quickly.*1
DATA MONITOR	Input/Output data in the ABS actuator and electric unit (control unit) can be read.
ACTIVE TEST	Diagnostic Test Mode in which CONSULT drives some actuators apart from the ABS actuator and electric unit (control unit) and also shifts some parameters in a specified range.
Function Test*2	This mode can show results of self-diagnosis of ECU with either "OK" or "NG". For engine, more practical tests regarding sensors/switches and/or actuators are available.
Work support	Components can be quickly and accurately adjusted.

*1: The following diagnosis information is erased by erasing.

- DTC
- Freeze frame data (FFD)

*2: Although "Function Test" is selectable, do not use its.

ECU IDENTIFICATION

ABS actuator and electric unit (control unit) part number can be read.

SELF DIAGNOSTIC RESULT

Refer to [BRC-50, "DTC Index"](#).

When "CRNT" is displayed on self-diagnosis result

- The system is presently malfunctioning.

When "PAST" is displayed on self-diagnosis result

- System malfunction in the past is detected, but the system is presently normal.

Freeze frame data (FFD)

When DTC is detected, a vehicle state shown below is recorded and displayed on CONSULT.

Item name	Display item
IGN counter (0 – 39)	<p>The number of times that ignition switch is turned ON after the DTC is detected is displayed.</p> <ul style="list-style-type: none"> • When "0" is displayed: It indicates that the system is presently malfunctioning. • When except "0" is displayed: It indicates that system malfunction in the past is detected, but the system is presently normal. <p>NOTE: Each time when ignition switch is turned OFF to ON, numerical number increases in 1 → 2 → 3...38 → 39. When the operation number of times exceeds 39, the number do not increase and "39" is displayed until self-diagnosis is erased.</p>

DATA MONITOR

NOTE:

The following table includes information (items) inapplicable to this vehicle. For information (items) applicable to this vehicle, refer to CONSULT display items.

×: Applicable

Item (Unit)	Monitor item selection		Note
	ECU INPUT SIGNALS	MAIN SIGNALS	
FR LH SENSOR [km/h (MPH)]	×	×	Wheel speed calculated by front LH wheel sensor is displayed.
FR RH SENSOR [km/h (MPH)]	×	×	Wheel speed calculated by front RH wheel sensor is displayed.

DIAGNOSIS SYSTEM [ABS ACTUATOR AND ELECTRIC UNIT (CONTROL UNIT)]

< SYSTEM DESCRIPTION >

[WITH VDC]

Item (Unit)	Monitor item selection		Note
	ECU INPUT SIGNALS	MAIN SIGNALS	
RR LH SENSOR [km/h (MPH)]	×	×	Wheel speed calculated by rear LH wheel sensor is displayed.
RR RH SENSOR [km/h (MPH)]	×	×	Wheel speed calculated by rear RH wheel sensor is displayed.
DECEL G-SEN (G)	×	×	Decel G detected by decel G sensor is displayed.
FR RH IN SOL (On/Off)		×	Operation status of front RH wheel ABS IN valve is displayed.
FR RH OUT SOL (On/Off)		×	Operation status of front RH wheel ABS OUT valve is displayed.
FR LH IN SOL (On/Off)		×	Operation status of front LH wheel ABS IN valve is displayed.
FR LH OUT SOL (On/Off)		×	Operation status of front LH wheel ABS OUT valve is displayed.
RR RH IN SOL (On/Off)		×	Operation status of rear RH wheel ABS IN valve is displayed.
RR RH OUT SOL (On/Off)		×	Operation status of rear RH wheel ABS OUT valve is displayed.
RR LH IN SOL (On/Off)		×	Operation status of rear LH wheel ABS IN valve is displayed.
RR LH OUT SOL (On/Off)		×	Operation status of rear LH wheel ABS OUT valve is displayed.
EBD WARN LAMP (On/Off)			Brake warning lamp ON/OFF status is displayed. *
STOP LAMP SW (On/Off)	×	×	Stop lamp switch signal input status is displayed.
MOTOR RELAY (On/Off)		×	ABS motor and motor relay status is displayed.
ACTUATOR RLY (On/Off)		×	ABS actuator relay status is displayed.
ABS WARN LAMP (On/Off)		×	ABS warning lamp ON/OFF status is displayed. *
OFF LAMP (On/Off)		×	VDC OFF indicator lamp ON/OFF status is displayed. *
OFF SW (On/Off)	×	×	VDC OFF switch signal input status is displayed.
SLIP/VDC LAMP (On/Off)		×	VDC warning lamp ON/OFF status is displayed. *
BATTERY VOLT (V)	×	×	Voltage supplied to ABS actuator and electric unit (control unit) is displayed.
GEAR	×	×	Current gear position judged from current gear position signal is displayed.
ENGINE SPEED [tr/min (rpm)]	×	×	Engine speed status is displayed.
YAW RATE SEN (d/s)	×	×	Yaw rate detected by yaw rate sensor is displayed.
R POSI SIG (On/Off)			R range signal input status judged from R range signal is displayed.
4WD MODE MON (2WD/AUTO)	×	×	AWD control status is displayed.
N POSI SIG (On/Off)			N range signal input status judged from N range signal is displayed.

DIAGNOSIS SYSTEM [ABS ACTUATOR AND ELECTRIC UNIT (CONTROL UNIT)]

< SYSTEM DESCRIPTION >

[WITH VDC]

Item (Unit)	Monitor item selection		Note
	ECU INPUT SIGNALS	MAIN SIGNALS	
P POSI SIG (On/Off)			P range signal input status judged from P range signal is displayed.
CV1 (On/Off)			Cut valve 1 operation status is displayed.
CV2 (On/Off)			Cut valve 2 operation status is displayed.
SV1 (On/Off)			Suction valve 1 operation status is displayed.
SV2 (On/Off)			Suction valve 2 operation status is displayed.
STOP LAMP SW2 (On/Off)			Brake pedal position switch signal input status is displayed.
ACCEL POS SIG (%)	×		Displays the Accelerator pedal position
SIDE G-SENSOR (m/s ²)	×		Side G detected by side G sensor is displayed.
STR ANGLE SIG (deg)	×		Steering angle detected by steering angle sensor is displayed.
EBD SIGNAL (On/Off)			EBD operation status is displayed.
ABS SIGNAL (On/Off)			ABS operation status is displayed.
TCS SIGNAL (On/Off)			TCS operation status is displayed.
VDC SIGNAL (On/Off)			VDC operation status is displayed.
EBD FAIL SIG (On/Off)			EBD fail-safe signal status is displayed.
ABS FAIL SIG (On/Off)			ABS fail-safe signal status is displayed.
TCS FAIL SIG (On/Off)			TCS fail-safe signal status is displayed.
VDC FAIL SIG (On/Off)			VDC fail-safe signal status is displayed.
CRANKING SIG (On/Off)			Cranking status is displayed.
FLUID LEV SW (On/Off)	×		Brake fluid level signal input status via CAN communication is displayed.

A
B
C
D
E
G
H
I
J
K
L
M
N
O
P

BRC

*: Refer to [BRC-14, "System Description"](#) for ON/OFF conditions of each warning lamp.

ACTIVE TEST

The active test is used to determine and identify details of a malfunction, based on self-diagnosis test result and data obtained in the DATA MONITOR. In response to instructions from CONSULT, instead of those from ABS actuator and electric unit (control unit) on the vehicle, a drive signal is sent to the actuator to check its operation.

CAUTION:

- Never perform ACTIVE TEST while driving the vehicle.
- Always bleed air from brake system before ACTIVE TEST.
- Never perform ACTIVE TEST when system is malfunctioning.

NOTE:

- When active test is performed while depressing the pedal, the pedal depressing stroke may change. This is not a malfunction.
- "TEST IS STOPPED" is displayed approx. 10 seconds after operation start.
- When performing active test again after "TEST IS STOPPED" is displayed, select "BACK".

DIAGNOSIS SYSTEM [ABS ACTUATOR AND ELECTRIC UNIT (CONTROL UNIT)]

< SYSTEM DESCRIPTION >

[WITH VDC]

- ABS warning lamp and brake warning lamp may turn ON during active test. This is not a malfunction.

ABS IN Valve and ABS OUT Valve

When “Up”, “Keep” or “Down” is selected on display screen, the following items are displayed when system is normal.

Test item	Display item	Display		
		Up	Keep	Down
FR RH SOL	FR RH IN SOL	Off	On	On
	FR RH OUT SOL	Off	Off	On*
FR LH SOL	FR LH IN SOL	Off	On	On
	FR LH OUT SOL	Off	Off	On*
RR RH SOL	RR RH IN SOL	Off	On	On
	RR RH OUT SOL	Off	Off	On*
RR LH SOL	RR LH IN SOL	Off	On	On
	RR LH OUT SOL	Off	Off	On*

*: Immediately after being selected, status is “On”. Status changes to “Off” after approx. 2 seconds.

ABS IN Valve (ACT) and ABS OUT Valve (ACT)

When “Up”, “ACT KEEP” or “ACT UP” is selected on display screen, the following items are displayed when system is normal.

Test item	Display item	Display		
		Up	ACT KEEP	ACT UP
FR RH ABS SOLE-NOID (ACT)	FR RH IN SOL	Off	Off	Off
	FR RH OUT SOL	Off	Off	Off
	CV1	Off	Off	Off
	CV2	Off	On	On
	SV1	Off	Off	Off
	SV2	Off	Off	On*
FR LH ABS SOLE-NOID (ACT)	FR LH IN SOL	Off	Off	Off
	FR LH OUT SOL	Off	Off	Off
	CV1	Off	On	On
	CV2	Off	Off	Off
	SV1	Off	Off	On*
	SV2	Off	Off	Off
RR RH ABS SOLE-NOID (ACT)	RR RH IN SOL	Off	Off	Off
	RR RH OUT SOL	Off	Off	Off
	CV1	Off	On	On
	CV2	Off	Off	Off
	SV1	Off	Off	On*
	SV2	Off	Off	Off
RR LH ABS SOLE-NOID (ACT)	RR LH IN SOL	Off	Off	Off
	RR LH OUT SOL	Off	Off	Off
	CV1	Off	Off	Off
	CV2	Off	On	On
	SV1	Off	Off	Off
	SV2	Off	Off	On*

*: Immediately after being selected, status is “On”. Status changes to “Off” after approx. 2 seconds.

DIAGNOSIS SYSTEM [ABS ACTUATOR AND ELECTRIC UNIT (CONTROL UNIT)]

< SYSTEM DESCRIPTION >

[WITH VDC]

ABS Motor

When "On" or "Off" is selected on display screen, the following items are displayed when system is normal.

Test item	Display item	Display	
		On	Off
ABS MOTOR	MOTOR RELAY	On	Off
	ACTUATOR RLY	On	On

A
B
C
D
E
G
H
I
J
K
L
M
N
O
P

BRC

ABS ACTUATOR AND ELECTRIC UNIT (CONTROL UNIT)

< ECU DIAGNOSIS INFORMATION >

[WITH VDC]

ECU DIAGNOSIS INFORMATION

ABS ACTUATOR AND ELECTRIC UNIT (CONTROL UNIT)

Reference Value

INFOID:000000009752902

CONSULT DATA MONITOR STANDARD VALUE

NOTE:

The following table includes information (items) inapplicable to this vehicle. For information (items) applicable to this vehicle, refer to CONSULT display items.

Monitor item	Condition	Reference values in normal operation
FR LH SENSOR	Vehicle stopped	0.00 km/h (MPH)
	When driving straight ahead*1	Nearly matches the speedometer display (within $\pm 10\%$)
FR RH SENSOR	Vehicle stopped	0.00 km/h (MPH)
	When driving straight ahead*1	Nearly matches the speedometer display (within $\pm 10\%$)
RR LH SENSOR	Vehicle stopped	0.00 km/h (MPH)
	When driving straight ahead*1	Nearly matches the speedometer display (within $\pm 10\%$)
RR RH SENSOR	Vehicle stopped	0.00 km/h (MPH)
	When driving straight ahead*1	Nearly matches the speedometer display (within $\pm 10\%$)
DECEL G-SEN	When stopped	-0.11 – 0.11 G
	During acceleration	Negative value
	During deceleration	Positive value
FR RH IN SOL*2	Active	On
	Not activated	Off
FR RH OUT SOL*2	Active	On
	Not activated	Off
FR LH IN SOL*2	Active	On
	Not activated	Off
FR LH OUT SOL*2	Active	On
	Not activated	Off
RR RH IN SOL*2	Active	On
	Not activated	Off
RR RH OUT SOL*2	Active	On
	Not activated	Off
RR LH IN SOL*2	Active	On
	Not activated	Off
RR LH OUT SOL*2	Active	On
	Not activated	Off
EBD WARN LAMP	When brake warning lamp is ON*3	On
	When brake warning lamp is OFF*3	Off
STOP LAMP SW	Brake pedal depressed	On
	Brake pedal not depressed	Off
MOTOR RELAY	Active	On
	Not activated	Off

ABS ACTUATOR AND ELECTRIC UNIT (CONTROL UNIT)

< ECU DIAGNOSIS INFORMATION >

[WITH VDC]

Monitor item	Condition	Reference values in normal operation
ACTUATOR RLY	Active	On
	Not activated (in fail-safe mode)	Off
ABS WARN LAMP	When ABS warning lamp is ON ^{*3}	On
	When brake warning lamp is OFF ^{*3}	Off
OFF LAMP	When VDC OFF indicator lamp is ON ^{*3}	On
	When VDC OFF indicator lamp is OFF ^{*3}	Off
OFF SW	VDC OFF switch ON	On
	VDC OFF switch OFF	Off
SLIP/VDC LAMP	When VDC warning lamp is ON ^{*3}	On
	When VDC warning lamp is OFF ^{*3}	Off
BATTERY VOLT	Ignition switch ON	10 – 16 V
GEAR	Driving	1 – 8 Depending on shift status
ENGINE SPEED	Engine stopped	0 rpm
	Engine running	Almost same reading as tachometer
YAW RATE SEN	Vehicle stopped	Approx. 0 d/s
	Turning right	Negative value
	Turning left	Positive value
R POSI SIG	When selector lever is in the R position	On
	When selector lever is in the other position than R	Off
4WD MODE MON	Always	Depending on AWD control status
N POSI SIG	When selector lever is in the N position	On
	When selector lever is in the other position than N	Off
P POSI SIG	When selector lever is in the P position	On
	When selector lever is in the other position than P	Off
CV1 ^{*2}	Active	On
	Not activated	Off
CV2 ^{*2}	Active	On
	Not activated	Off
SV1 ^{*2}	Active	On
	Not activated	Off
SV2 ^{*2}	Active	On
	Not activated	Off
STOP LAMP SW2	Brake pedal depressed	On
	Brake pedal not depressed	Off
ACCEL POS SIG	Never depress accelerator pedal (with ignition switch ON)	0%
	Depress accelerator pedal (with ignition switch ON)	0 – 100%
SIDE G-SENSOR	Vehicle stopped	Approx. 0 m/s ²
	Turning right	Negative value
	Turning left	Positive value
STR ANGLE SIG	When driving straight	0±2.5°
	When steering wheel is steered to RH by 90°	Approx. +90°
	When steering wheel is steered to LH by 90°	Approx. -90°

A
B
C
D
E
BRC
G
H
I
J
K
L
M
N
O
P

ABS ACTUATOR AND ELECTRIC UNIT (CONTROL UNIT)

< ECU DIAGNOSIS INFORMATION >

[WITH VDC]

Monitor item	Condition	Reference values in normal operation
EBD SIGNAL	EBD is activated	On
	EBD is not activated	Off
ABS SIGNAL	ABS is activated	On
	ABS is not activated	Off
TCS SIGNAL	TCS is activated	On
	TCS is not activated	Off
VDC SIGNAL	VDC is activated	On
	VDC is not activated	Off
EBD FAIL SIG	In EBD fail-safe	On
	EBD is normal	Off
ABS FAIL SIG	In ABS fail-safe	On
	ABS is normal	Off
TCS FAIL SIG	In TCS fail-safe	On
	TCS is normal	Off
VDC FAIL SIG	In VDC fail-safe	On
	VDC is normal	Off
CRANKING SIG	At cranking	On
	Other than at cranking	Off
FLUID LEV SW	When brake fluid level switch is ON (brake fluid level is less than the specified level)	On
	When brake fluid level switch is OFF	Off

*1: Confirm tire pressure is standard value.

*2: Refer to "valve operation" in [BRC-14, "System Description"](#) for valve operation of each valve.

*3: Refer to [BRC-14, "System Description"](#) for ON/OFF conditions of each warning lamp and indicator lamp.

Fail-safe

INFOID:000000009752903

VDC FUNCTION, TCS FUNCTION AND BRAKE LIMITED SLIP DIFFERENTIAL (BLSD) FUNCTION
VDC warning lamp in combination meter turn ON when a malfunction occurs in system [ABS actuator and electric unit (control unit)]. The control is suspended for VDC function, TCS function and brake limited slip differential (BLSD) function. The vehicle status becomes the same as models without VDC function, TCS function and brake limited slip differential (BLSD) function. However, ABS function and EBD function are operated normally.

ABS FUNCTION

ABS warning lamp and VDC warning lamp in combination meter turn ON when a malfunction occurs in system [ABS actuator and electric unit (control unit)]. The control is suspended for VDC function, TCS function, ABS function and brake limited slip differential (BLSD) function. The vehicle status becomes the same as models without VDC function, TCS function, ABS function and brake limited slip differential (BLSD) function. However, EBD function is operated normally.

NOTE:

ABS self-diagnosis sound may be heard the same as in the normal condition, because self-diagnosis is performed when ignition switch turns ON and when vehicle initially starts.

EBD FUNCTION

ABS warning lamp, brake warning lamp and VDC warning lamp in combination meter turn ON when a malfunction occurs in system [ABS actuator and electric unit (control unit)]. The control is suspended for VDC function, TCS function, ABS function, EBD function and brake limited slip differential (BLSD) function. The vehicle status becomes the same as models without VDC function, TCS function, ABS function, EBD function and brake limited slip differential (BLSD) function.

ABS ACTUATOR AND ELECTRIC UNIT (CONTROL UNIT)

< ECU DIAGNOSIS INFORMATION >

[WITH VDC]

DTC	Malfunction detected condition	Fail-safe condition	A
C1101	When an open circuit is detected in rear RH wheel sensor circuit.		A
C1102	When an open circuit is detected in rear LH wheel sensor circuit.		B
C1103	When an open circuit is detected in front RH wheel sensor circuit.		C
C1104	When an open circuit is detected in front LH wheel sensor circuit.		D
C1105	<ul style="list-style-type: none"> • When a short circuit is detected in rear RH wheel sensor circuit. • When power supply voltage of rear RH wheel sensor is in following state. <ul style="list-style-type: none"> - Rear RH wheel sensor power supply voltage: $7.5\text{ V} \geq$ Rear RH wheel sensor power supply voltage - Rear RH wheel sensor power supply voltage: $16\text{ V} \leq$ Rear RH wheel sensor power supply voltage • When distance between rear RH wheel sensor and rear RH wheel sensor rotor is large. • When installation of rear RH wheel sensor or rear RH wheel sensor rotor is not normal. 	The following functions are suspended. <ul style="list-style-type: none"> • VDC function • TCS function • ABS function • EBD function (only when both 2 rear wheels are malfunctioning) • Brake limited slip differential (BLSD) function 	E
C1106	<ul style="list-style-type: none"> • When a short circuit is detected in rear LH wheel sensor circuit. • When power supply voltage of rear LH wheel sensor is in following state. <ul style="list-style-type: none"> - Rear LH wheel sensor power supply voltage: $7.5\text{ V} \geq$ Rear LH wheel sensor power supply voltage - Rear LH wheel sensor power supply voltage: $16\text{ V} \leq$ Rear LH wheel sensor power supply voltage • When distance between rear LH wheel sensor and rear LH wheel sensor rotor is large. • When installation of rear LH wheel sensor or rear LH wheel sensor rotor is not normal. 		G
C1107	<ul style="list-style-type: none"> • When a short circuit is detected in front RH wheel sensor circuit. • When power supply voltage of front RH wheel sensor is in following state. <ul style="list-style-type: none"> - Front RH wheel sensor power supply voltage: $7.5\text{ V} \geq$ Front RH wheel sensor power supply voltage - Front RH wheel sensor power supply voltage: $16\text{ V} \leq$ Front RH wheel sensor power supply voltage • When distance between front RH wheel sensor and front RH wheel sensor rotor is large. • When installation of front RH wheel sensor or front RH wheel sensor rotor is not normal. 		H
C1108	<ul style="list-style-type: none"> • When a short circuit is detected in front LH wheel sensor circuit. • When power supply voltage of front LH wheel sensor is in following state. <ul style="list-style-type: none"> - Front LH wheel sensor power supply voltage: $7.5\text{ V} \geq$ Front LH wheel sensor power supply voltage - Front LH wheel sensor power supply voltage: $16\text{ V} \leq$ Front LH wheel sensor power supply voltage • When distance between front LH wheel sensor and front LH wheel sensor rotor is large. • When installation of front LH wheel sensor or front LH wheel sensor rotor is not normal. 		I
C1109	When ignition power supply voltage is in following state. <ul style="list-style-type: none"> • Ignition power supply voltage: $10\text{ V} \geq$ Ignition power supply voltage. • Ignition power supply voltage: $16\text{ V} \leq$ Ignition power supply voltage. 		J
C1110	When there is an internal malfunction in the ABS actuator and electric unit (control unit).	K	
C1111	When a malfunction is detected in motor or motor relay.	L	
		M	
		N	
		O	
		P	

BRC

ABS ACTUATOR AND ELECTRIC UNIT (CONTROL UNIT)

< ECU DIAGNOSIS INFORMATION >

[WITH VDC]

DTC	Malfunction detected condition	Fail-safe condition
C1113	When a malfunction is detected in decel G signal, or signal line of yaw rate/side/decel G sensor is open or shorted.	The following functions are suspended. <ul style="list-style-type: none"> • VDC function • TCS function • ABS function (AWD) • Brake limited slip differential (BLSD) function
C1115	When difference in wheel speed between any wheel and others is detected the vehicle is driven, because of installation of other tires than specified.	The following functions are suspended. <ul style="list-style-type: none"> • VDC function • TCS function • ABS function • EBD function • Brake limited slip differential (BLSD) function
C1116	When stop lamp switch signal is not input when brake pedal operates.	The following functions are suspended. <ul style="list-style-type: none"> • VDC function • TCS function • Brake limited slip differential (BLSD) function
C1120	When a malfunction is detected in front LH ABS IN valve.	The following functions are suspended. <ul style="list-style-type: none"> • VDC function • TCS function • ABS function • EBD function • Brake limited slip differential (BLSD) function
C1121	When a malfunction is detected in front LH ABS OUT valve.	
C1122	When a malfunction is detected in front RH ABS IN valve.	
C1123	When a malfunction is detected in front RH ABS OUT valve.	
C1124	When a malfunction is detected in rear LH ABS IN valve.	
C1125	When a malfunction is detected in rear LH ABS OUT valve.	
C1126	When a malfunction is detected in rear RH ABS IN valve.	
C1127	When a malfunction is detected in rear RH ABS OUT valve.	
C1130	When a malfunction is detected in ECM system.	The following functions are suspended. <ul style="list-style-type: none"> • VDC function • TCS function • Brake limited slip differential (BLSD) function
C1140	When a malfunction is detected in actuator relay.	The following functions are suspended. <ul style="list-style-type: none"> • VDC function • TCS function • ABS function • EBD function • Brake limited slip differential (BLSD) function
C1143	When a malfunction is detected in steering angle sensor.	The following functions are suspended. <ul style="list-style-type: none"> • VDC function • TCS function • ABS function (AWD) • Brake limited slip differential (BLSD) function
C1144	When neutral position adjustment of steering angle sensor is not complete.	The following functions are suspended. <ul style="list-style-type: none"> • VDC function • TCS function • Brake limited slip differential (BLSD) function

ABS ACTUATOR AND ELECTRIC UNIT (CONTROL UNIT)

< ECU DIAGNOSIS INFORMATION >

[WITH VDC]

DTC	Malfunction detected condition	Fail-safe condition
C1145	When a malfunction is detected in yaw rate signal, or signal line of yaw rate/side/decel G sensor is open or shorted.	The following functions are suspended. <ul style="list-style-type: none"> • VDC function • TCS function • ABS function (AWD) • Brake limited slip differential (BLSD) function
C1146	When a malfunction is detected in side G signal, or signal line of yaw rate/side/decel G sensor is open or shorted.	
C1155	When brake fluid level low signal is detected.	The following functions are suspended. <ul style="list-style-type: none"> • VDC function • TCS function • Brake limited slip differential (BLSD) function
C1164	When a malfunction is detected in cut valve 1.	The following functions are suspended. <ul style="list-style-type: none"> • VDC function • TCS function • ABS function • EBD function • Brake limited slip differential (BLSD) function
C1165	When a malfunction is detected in cut valve 2.	
C1166	When a malfunction is detected in suction valve 1.	
C1167	When a malfunction is detected in suction valve 2.	
C1170	When the information in ABS actuator and electric unit (control unit) is not the same.	The following functions are suspended. <ul style="list-style-type: none"> • VDC function • TCS function • ABS function • Brake limited slip differential (BLSD) function
C1176	When brake pedal position switch signal is not input when brake pedal operates.	The following functions are suspended. <ul style="list-style-type: none"> • VDC function • TCS function • Brake limited slip differential (BLSD) function
U1000	When CAN communication signal is not continuously transmitted or received for 2 seconds or more.	The following functions are suspended. <ul style="list-style-type: none"> • VDC function • TCS function • Brake limited slip differential (BLSD) function
U1010	When detecting error during the initial diagnosis of CAN controller of ABS actuator and electric unit (control unit).	

A
B
C
D
E
BRC
G
H
I
J
K
L

DTC Inspection Priority Chart

INFOID:000000009752904

When multiple DTCs are displayed simultaneously, check one by one depending on the following priority list.

Priority	Detected item (DTC)
1	<ul style="list-style-type: none"> • U1000 CAN COMM CIRCUIT • U1010 CONTROL UNIT (CAN)
2	<ul style="list-style-type: none"> • C1110 CONTROLLER FAILURE • C1170 VARIANT CODING
3	<ul style="list-style-type: none"> • C1130 ENGINE SIGNAL 1 • C1144 ST ANG SEN SIGNAL
4	<ul style="list-style-type: none"> • C1109 BATTERY VOLTAGE [ABNORMAL] • C1111 PUMP MOTOR • C1140 ACTUATOR RLY

M
N
O
P

ABS ACTUATOR AND ELECTRIC UNIT (CONTROL UNIT)

< ECU DIAGNOSIS INFORMATION >

[WITH VDC]

Priority	Detected item (DTC)
5	<ul style="list-style-type: none"> • C1101 RR RH SENSOR-1 • C1102 RR LH SENSOR-1 • C1103 FR RH SENSOR-1 • C1104 FR LH SENSOR-1 • C1105 RR RH SENSOR-2 • C1106 RR LH SENSOR-2 • C1107 FR RH SENSOR-2 • C1108 FR LH SENSOR-2 • C1113 G-SENSOR • C1115 ABS SENSOR [ABNORMAL SIGNAL] • C1116 STOP LAMP SW • C1120 FR LH IN ABS SOL • C1121 FR LH OUT ABS SOL • C1122 FR RH IN ABS SOL • C1123 FR RH OUT ABS SOL • C1124 RR LH IN ABS SOL • C1125 RR LH OUT ABS SOL • C1126 RR RH IN ABS SOL • C1127 RR RH OUT ABS SOL • C1143 ST ANG SEN CIRCUIT • C1145 YAW RATE SENSOR • C1146 SIDE G SEN CIRCUIT • C1164 CV 1 • C1165 CV 2 • C1166 SV 1 • C1167 SV 2 • C1176 STOP LAMP SW2
6	<ul style="list-style-type: none"> • C1155 BR FLUID LEVEL LOW

DTC Index

INFOID:000000009752905

DTC	Display Item	Refer to
C1101	RR RH SENSOR-1	BRC-64, "DTC Logic"
C1102	RR LH SENSOR-1	
C1103	FR RH SENSOR-1	
C1104	FR LH SENSOR-1	
C1105	RR RH SENSOR-2	BRC-67, "DTC Logic"
C1106	RR LH SENSOR-2	
C1107	FR RH SENSOR-2	
C1108	FR LH SENSOR-2	
C1109	BATTERY VOLTAGE [ABNORMAL]	BRC-73, "DTC Logic"
C1110	CONTROLLER FAILURE	BRC-75, "DTC Logic"
C1111	PUMP MOTOR	BRC-76, "DTC Logic"
C1113	G-SENSOR	BRC-78, "DTC Logic"
C1115	ABS SENSOR [ABNORMAL SIGNAL]	BRC-81, "DTC Logic"
C1116	STOP LAMP SW	BRC-87, "DTC Logic"
C1120	FR LH IN ABS SOL	BRC-91, "DTC Logic"
C1121	FR LH OUT ABS SOL	BRC-93, "DTC Logic"
C1122	FR RH IN ABS SOL	BRC-91, "DTC Logic"
C1123	FR RH OUT ABS SOL	BRC-93, "DTC Logic"
C1124	RR LH IN ABS SOL	BRC-91, "DTC Logic"
C1125	RR LH OUT ABS SOL	BRC-93, "DTC Logic"
C1126	RR RH IN ABS SOL	BRC-91, "DTC Logic"

ABS ACTUATOR AND ELECTRIC UNIT (CONTROL UNIT)

< ECU DIAGNOSIS INFORMATION >

[WITH VDC]

DTC	Display Item	Refer to	
C1127	RR RH OUT ABS SOL	BRC-93, "DTC Logic"	A
C1130	ENGINE SIGNAL 1	BRC-95, "DTC Logic"	
C1140	ACTUATOR RLY	BRC-96, "DTC Logic"	B
C1143	ST ANG SEN CIRCUIT	BRC-98, "DTC Logic"	
C1144	ST ANG SEN SIGNAL	BRC-100, "DTC Logic"	
C1145	YAW RATE SENSOR	BRC-78, "DTC Logic"	C
C1146	SIDE G SEN CIRCUIT		
C1155	BR FLUID LEVEL LOW	BRC-101, "DTC Logic"	D
C1164	CV 1	BRC-104, "DTC Logic"	
C1165	CV 2		
C1166	SV 1	BRC-106, "DTC Logic"	E
C1167	SV 2		
C1170	VARIANT CODING	BRC-75, "DTC Logic"	BRC
C1176	STOP LAMP SW2	BRC-108, "DTC Logic"	
U1000	CAN COMM CIRCUIT	BRC-112, "DTC Logic"	
U1010	CONTROL UNIT (CAN)	BRC-113, "DTC Logic"	G

A
B
C
D
E
G
H
I
J
K
L
M
N
O
P

BRAKE CONTROL SYSTEM

[WITH VDC]

< WIRING DIAGRAM >

BRAKE CONTROL SYSTEM

Connector No.	B7
Connector Name	WIRE TO WIRE
Connector Type	TH2FW-NH

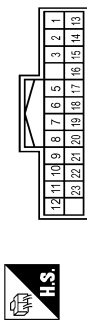

Connector No.	B88
Connector Name	YAW RATE / SBE / DECEL SENSOR
Connector Type	SG208EB



Connector No.	B44
Connector Name	REAR WHEEL SENSOR LH
Connector Type	RH02MB



Connector No.	E8
Connector Name	WIRE TO WIRE
Connector Type	SAA38MB-RS10-SLZ2



Terminal No.	Color Of Wire	Signal Name [Specification]
1	R	-
2	W	-
3	V	-
4	G	-
5	LG	-
6	R	-
7	P	-
8	L	-
9	G	-
10	G	-
11	L	-
12	Y	-
13	P	-
14	L	-
15	B	-
16	BR	-
17	B	-
18	B	-
19	B	-
20	G	-
21	W	-
22	R	-
23	SHIELD	-

Terminal No.	Color Of Wire	Signal Name [Specification]
1	G	-
2	R	-
3	B	-
4	W	-
5	R	-
6	W	-

Connector No.	B41
Connector Name	REAR WHEEL SENSOR RH
Connector Type	RH02MB



Terminal No.	Color Of Wire	Signal Name [Specification]
1	B	-
2	BR	-

Connector No.	B45
Connector Name	REAR WHEEL SENSOR RH
Connector Type	RH02MB



Terminal No.	Color Of Wire	Signal Name [Specification]
1	L	-
2	P	-

JRFWC1196GB

A
B
C
D
E
BRC
G
H
I
J
K
L
M
N
O
P

BRAKE CONTROL SYSTEM

< WIRING DIAGRAM >

[WITH VDC]

BRAKE CONTROL SYSTEM

40	P	-
41	Y	-
42	L	-
43	BR	-
44	G	-
45	BR	-
46	Y	-
47	SB	-
48	LG	-

Connector No.	E15
Connector Name	SMALLER INTELLIGENT POWER DISTRIBUTION MODULE ENGINE
Connector Type	NS18P1P-CS

52	53	50	49	48			
52	51	50	55	57	56	55	54



Terminal No.	Color Of Wire	Signal Name [Specification]
48	BR	-
49	Y	-
50	G	-
51	L	-
52	P	-
53	G	-
54	P	-
55	G	-
56	SB	-
57	O	-
58	LG	-
59	V	-
60	SB	-
61	LG	-
62	O	-

Connector No.	E22
Connector Name	FRONT WHEEL SENSOR LH
Connector Type	RH02FGY



Terminal No.	Color Of Wire	Signal Name [Specification]
1	GS	-
2	BR	-

Connector No.	E35
Connector Name	ABS ACTUATOR AND ELECTRIC UNIT (CONTROL UNIT)
Connector Type	RH28FB-NL4-LH

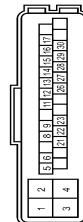

Terminal No.	Color Of Wire	Signal Name [Specification]
1	W	BAT (MTR)
2	L	BAT (SOL)
3	B	GND (SOL)
4	B	GND (MTR)
5	GR	VDC OFF SW
6	GR	BRAKE PEDAL POSITION SW
8	SB	STOP LAMP SW
9	P	CAN-L
11	BR	DP RR
12	W	DS FR
13	W	DS RR
14	R	SEAL+
15	R	DS RR
16	V	IGN
17	W	REVERSE SIGNAL
21	Y	DP FR
22	L	CAN-H
23	LG	DP FL

26	GR	DP RL
27	BR	DS FL
28	B	GND
29	W	SERIAL-
30	O	DS RL



Connector No.	E37
Connector Name	BRAKE FLUID LEVEL SWITCH
Connector Type	YH02FGY



Terminal No.	Color Of Wire	Signal Name [Specification]
1	LG	-
2	B	-

Connector No.	E39
Connector Name	FRONT WHEEL SENSOR RH
Connector Type	RH02FGY



Terminal No.	Color Of Wire	Signal Name [Specification]
1	Y	-
2	W	-

Connector No.	E102
Connector Name	STOP LAMP SWITCH
Connector Type	MH4FW-LC



Terminal No.	Color Of Wire	Signal Name [Specification]
1	W	-
2	SB	-
3	GR	-
4	LG	-

Connector No.	E105
Connector Name	WIRE TO WIRE
Connector Type	TH80MTP-CS16-1M4

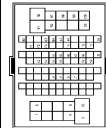

Terminal No.	Color Of Wire	Signal Name [Specification]
1	L	-
4	Y	-
5	GR	-
6	P	-
9	G	-
10	R	-
34	O	-
35	GR	-
39	B	-
40	B	-
52	SB	-
53	BR	-
54	V	-
55	O	-
58	L	-
59	Y	-

JRFWC1197GB

BRAKE CONTROL SYSTEM

< WIRING DIAGRAM >

[WITH VDC]

BRAKE CONTROL SYSTEM

Terminal No.	Color Of Wire	Signal Name [Specification]
84	LG	-
82	GR	-
83	BR	-
67	W	-
12	O	-
13	P	-
14	L	-
68	SB	-
70	R	-
71	LG	-
72	V	-
73	L	-
76	R	-
78	B	-
79	W	-
80	L	-
83	Y	-
84	LG	-
85	GR	-
86	O	-
80	SHIELD	-
81	G	-
92	R	-
95	BR	-
96	P	-
97	GR	-
98	W	-
99	V	-
100	O	-

Connector No.	E107
Connector Name	WIRE TO WIRE
Connector Type	TH24MW-NH



Terminal No.	Color Of Wire	Signal Name [Specification]
1	SB	-
2	V	-
3	G	-
6	O	-
7	R	-
8	SB	-
9	R	-

Terminal No.	Color Of Wire	Signal Name [Specification]
10	G	-
11	O	-
12	O	-
13	W	-
14	P	-
15	L	-
16	SB	-
17	O	-
18	Y	-
19	G	-
20	B	-
21	W	-
22	R	-
23	SHIELD	-

Connector No.	E112
Connector Name	BRAKE PEDAL POSITION SWITCH
Connector Type	M02FBR-LC



Terminal No.	Color Of Wire	Signal Name [Specification]
1	O	-
2	G	-

Connector No.	E118
Connector Name	STOP LAMP SWITCH
Connector Type	M02FB-LC



Terminal No.	Color Of Wire	Signal Name [Specification]
2	SB	-

Connector No.	F1
Connector Name	WIRE TO WIRE
Connector Type	SMA38FB-RS10-SJZ2



Terminal No.	Color Of Wire	Signal Name [Specification]
1	P	-
2	L	-
3	Y	-
4	BG	-
5	LG	-
6	SB	-
7	G	-
8	R	-
10	BR	-
11	O	-
12	G	-
13	BG	-
14	L	-
15	BR	-
16	P	-
17	SB	-
18	G	-
19	G	-
20	BR	-
21	G	-
22	BR	-
23	SHIELD	-
24	R	-
25	R	-
26	G	-
27	B	-
28	R	-
29	W	-
30	R	-
31	BG	-

Terminal No.	Color Of Wire	Signal Name [Specification]
32	LG	-
33	BR	-
37	G	-
39	B	-
40	P	-
41	BR	-
42	W	-
43	L	-
44	G	-
45	BR	-
46	R	-
47	Y	-
48	GR	-

Connector No.	F49
Connector Name	PARK / NEUTRAL POSITION SWITCH
Connector Type	FEA03FG-LC



Terminal No.	Color Of Wire	Signal Name [Specification]
2	SB	-
3	BR	-

Connector No.	F57
Connector Name	BACK-UP LAMP SWITCH
Connector Type	FR02FB



A
B
C
D
E
BRC
G
H
I
J
K
L
M
N
O
P

BRAKE CONTROL SYSTEM

< WIRING DIAGRAM >

[WITH VDC]

BRAKE CONTROL SYSTEM

Terminal No.	Color Of Wire	Signal Name [Specification]
1	G	—
2	SB	—

Connector No.	M28
Connector Name	YDC OFF SWITCH
Connector Type	TH08FB-NH



Terminal No.	Color Of Wire	Signal Name [Specification]
1	SB	—
2	B	—
3	V	—
4	GR	—

Connector No.	M30
Connector Name	STEERING ANGLE SENSOR
Connector Type	TH08FW-NH



Terminal No.	Color Of Wire	Signal Name [Specification]
1	B	—
2	P	—
4	LG	—
5	L	—

Connector No.	M31
Connector Name	PARKING BRAKE SWITCH
Connector Type	F01EB-A

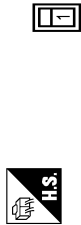

Terminal No.	Color Of Wire	Signal Name [Specification]
1	SB	—

Connector No.	M34
Connector Name	COMBINATION METER
Connector Type	TH40FW-NH

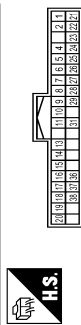

Terminal No.	Color Of Wire	Signal Name [Specification]
1	L	CAN-H
2	P	CAN-L
4	V	VEHICLE SPEED SIGNAL (B-PULSE) [With front fog lamp]
5	G	VEHICLE SPEED SIGNAL (B-PULSE) [Without front fog lamp]
6	BR	PADDLE SHIFTER UP SWITCH SIGNAL
7	R	FUEL LEVEL SENSOR SIGNAL
8	P	AIR BAG SIGNAL
9	Y	— [Without front fog lamp]
10	G	— [With front fog lamp]
11	SB	STOP LIGHT SIGNAL [Without front fog lamp]
12	SB	STOP LIGHT SIGNAL [With front fog lamp]
13	B	PARKING BRAKE SWITCH SIGNAL
14	R	PARKING BRAKE SWITCH SIGNAL
15	L	ILLUMINATION CONTROL SIGNAL [With front fog lamp]
16	O	ILLUMINATION CONTROL SIGNAL [Without front fog lamp]
17	V	MANUAL MODE SHIFT UP SIGNAL [With front fog lamp]
18	V	MANUAL MODE SHIFT UP SIGNAL [Without front fog lamp]
19	L	ACC POWER SUPPLY
20	O	MANUAL MODE SHIFT DOWN SIGNAL [With front fog lamp]
21	O	MANUAL MODE SHIFT DOWN SIGNAL [Without front fog lamp]

16	W	MANUAL MODE SHIFT DOWN SIGNAL [With front fog lamp]
17	G	MANUAL MODE SHIFT DOWN SIGNAL [Without front fog lamp]
18	W	WASHER LEVEL SWITCH SIGNAL [With front fog lamp]
19	GR	SECURITY SIGNAL
20	LG	AMBIENT SENSOR SIGNAL
21	R	AMBIENT SENSOR GROUND [With front fog lamp]
22	B	AMBIENT SENSOR GROUND [Without front fog lamp]
23	B	GROUND
24	L	FUEL LEVEL SENSOR GROUND
25	B	VDC GROUND
26	V	PADDLE SHIFTER DOWN SWITCH SIGNAL
27	LG	BATTERY POWER SUPPLY
28	LG	IGNITION SIGNAL
29	V	RESERVE SIGNAL (Without front fog lamp)
30	V	RESERVE SIGNAL (With front fog lamp)
31	P	A/C AUTO AMP CONNECTION RECOGNITION SIGNAL
32	LG	MANUAL MODE SIGNAL [With front fog lamp]
33	Y	MANUAL MODE SIGNAL [Without front fog lamp]
34	G	NON-MANUAL MODE SIGNAL [With front fog lamp]
35	G	NON-MANUAL MODE SIGNAL [Without front fog lamp]
36	Y	—
37	Y	—
38	P	ALTERNATOR SIGNAL

Connector No.	M77
Connector Name	WIRE TO WIRE
Connector Type	TH08FW-2S16-TM



Terminal No.	Color Of Wire	Signal Name [Specification]
1	L	—
4	V	—
5	W	—
9	R	—
10	R	—
34	LG	—
35	SB	—
36	B	—
37	P	—
52	R	—

53	L	—
54	SB	—
55	P	—
58	LG	—
59	G	—
64	G	—
65	GR	—
66	Y	—
67	V	—
68	R	—
70	V	—
71	R	—
72	GR	—
73	G	—
74	W	—
78	LG	—
79	V	—
80	LG	—
83	P	—
84	G	—
85	BR	—
86	LG	—
90	SHIELD	—
91	Y	—
92	BR	—
95	R	— [Without Intelligent Key]
96	Y	— [With Intelligent Key]
98	L	—
99	W	—
100	LG	—

Connector No.	M80
Connector Name	MULTI-DISPLAY UNIT
Connector Type	TH18FW-NH



BRAKE CONTROL SYSTEM

< WIRING DIAGRAM >

[WITH VDC]

A
B
C
D
E
G
H
I
J
K
L
M
N
O
P

BRC

BRAKE CONTROL SYSTEM

Terminal No.	Color of Wire	Signal Name [Specification]
1	V	BAT
2	V	ILL
5	GR	ILL CONT
6	L	CAN-H
7	SB	IGN
10	B	GND
11	B	GND
12	P	CAN-L

JRFWC1200GB

BASIC INSPECTION

DIAGNOSIS AND REPAIR WORK FLOW

Work Flow

INFOID:000000009752907

DETAILED FLOW

1. INTERVIEW FROM THE CUSTOMER

Clarify customer complaints before inspection. First of all, perform an interview utilizing [BRC-59, "Diagnostic Work Sheet"](#) and reproduce the symptom as well as fully understand it. Ask customer about his/her complaints carefully. Check symptoms by driving vehicle with customer, if necessary.

CAUTION:

Customers are not professional. Never guess easily like “maybe the customer means that...,” or “maybe the customer mentions this symptom”.

>> GO TO 2.

2. CHECK SYMPTOM

Reproduce the symptom that is indicated by the customer, based on the information from the customer obtained by interview. Also check that the symptom is not caused by fail-safe mode. Refer to [BRC-46, "Fail-safe"](#).

CAUTION:

When the symptom is caused by normal operation, fully inspect each portion and obtain the understanding of customer that the symptom is not caused by a malfunction.

>> GO TO 3.

3. PERFORM SELF-DIAGNOSIS

 With CONSULT

Perform self-diagnosis for “ABS”.

Is DTC detected?

YES >> Record or print self-diagnosis results and freeze frame data (FFD). GO TO 4.

NO >> GO TO 6.

4. RECHECK THE SYMPTOM

 With CONSULT

1. Erase self-diagnostic results for “ABS”.
2. Perform DTC confirmation procedures for the error-detected system.

NOTE:

If some DTCs are detected at the same time, determine the order for performing the diagnosis based on [BRC-49, "DTC Inspection Priority Chart"](#) [ABS actuator and electric unit (control unit)].

Is any DTC detected?

YES >> GO TO 5.

NO >> Check harness and connectors based on the information obtained by interview. Refer to [GI-46, "Intermittent Incident"](#).

5. REPAIR OR REPLACE ERROR-DETECTED PART

- Repair or replace error-detected parts.
- Reconnect part or connector after repairing or replacing.
- When DTC is detected, erase self-diagnostic result for “ABS”.

>> GO TO 7.

6. IDENTIFY ERROR-DETECTED SYSTEM BY SYMPTOM DIAGNOSIS

Estimate error-detected system based on symptom diagnosis and perform inspection.

Can the error-detected system be identified?

DIAGNOSIS AND REPAIR WORK FLOW

[WITH VDC]

< BASIC INSPECTION >

YES >> GO TO 7.

NO >> Check harness and connectors based on the information obtained by interview. Refer to [GI-46](#), "Intermittent Incident".

7. FINAL CHECK

④ With CONSULT

1. Check the reference value for "ABS".
2. Recheck the symptom and check that the symptom is not reproduced on the same conditions.

Is the symptom reproduced?

YES >> GO TO 3.

NO >> INSPECTION END

Diagnostic Work Sheet

INFOID:000000009752908

Description

- In general, customers have their own criteria for a problem. Therefore, it is important to understand the symptom and status well enough by asking the customer about his/her concerns carefully. To systemize all the information for the diagnosis, prepare the interview sheet referring to the interview points.
- In some cases, multiple conditions that appear simultaneously may cause a DTC to be detected.

INTERVIEW SHEET SAMPLE

Interview sheet					
Customer name		MR/MS	Registration number	Initial year registration	
			Vehicle type	VIN	
Storage date			Engine	Mileage	km (Mile)
Symptom	<input type="checkbox"/> Does not operate () function				
	<input type="checkbox"/> Warning lamp for () turns ON.				
	<input type="checkbox"/> Noise <input type="checkbox"/> Vibration				
	<input type="checkbox"/> Other ()				
First occurrence	<input type="checkbox"/> Recently <input type="checkbox"/> Other ()				
Frequency of occurrence	<input type="checkbox"/> Always <input type="checkbox"/> Under a certain conditions of <input type="checkbox"/> Sometimes (time(s)/day)				
Climate conditions	<input type="checkbox"/> Irrelevant				
	Weather	<input type="checkbox"/> Fine <input type="checkbox"/> Cloud <input type="checkbox"/> Rain <input type="checkbox"/> Snow <input type="checkbox"/> Others ()			
	Temperature	<input type="checkbox"/> Hot <input type="checkbox"/> Warm <input type="checkbox"/> Cool <input type="checkbox"/> Cold <input type="checkbox"/> Temperature [Approx. °C (°F)]			
	Relative humidity	<input type="checkbox"/> High <input type="checkbox"/> Moderate <input type="checkbox"/> Low			
Road conditions	<input type="checkbox"/> Urban area <input type="checkbox"/> Suburb area <input type="checkbox"/> Highway <input type="checkbox"/> Mountainous road (uphill or downhill) <input type="checkbox"/> Rough road				
Operating condition, etc.	<input type="checkbox"/> Irrelevant <input type="checkbox"/> When engine starts <input type="checkbox"/> During idling <input type="checkbox"/> During driving <input type="checkbox"/> During acceleration <input type="checkbox"/> At constant speed driving <input type="checkbox"/> During deceleration <input type="checkbox"/> During cornering (right curve or left curve) <input type="checkbox"/> When steering wheel is steered (to right or to left)				

DIAGNOSIS AND REPAIR WORK FLOW

< BASIC INSPECTION >

[WITH VDC]

Interview sheet

Customer name	MR/MS	Registration number		Initial year registration	
		Vehicle type		VIN	
Storage date		Engine		Mileage	km (Mile)
Other conditions					

Memo

ADDITIONAL SERVICE WHEN REPLACING ABS ACTUATOR AND ELECTRIC UNIT (CONTROL UNIT)

< BASIC INSPECTION >

[WITH VDC]

ADDITIONAL SERVICE WHEN REPLACING ABS ACTUATOR AND ELECTRIC UNIT (CONTROL UNIT)

Description

INFOID:000000009752909

When replaced the ABS actuator and electric unit (control unit), Perform steering angle sensor neutral position. Refer to [BRC-62. "Work Procedure"](#).

- A
- B
- C
- D
- E
- BRC**
- G
- H
- I
- J
- K
- L
- M
- N
- O
- P

ADJUSTMENT OF STEERING ANGLE SENSOR NEUTRAL POSITION

< BASIC INSPECTION >

[WITH VDC]

ADJUSTMENT OF STEERING ANGLE SENSOR NEUTRAL POSITION

Description

INFOID:000000009752910

Always adjust the neutral position of steering angle sensor before driving when the following operation is performed.

×: Required —: Not required

Procedure	Adjust the neutral position of steering angle sensor
Removing/ installing ABS actuator and electric unit (control unit)	—
Replacing ABS actuator and electric unit (control unit)	×
Removing/installing steering angle sensor	×
Replacing steering angle sensor	×
Removing/installing steering components	×
Replacing steering components	×
Removing/installing suspension components	×
Replacing suspension components	×
Removing/installing tire	—
Replacing tire	—
Tire rotation	—
Adjusting wheel alignment.	×

Work Procedure

INFOID:000000009752911

ADJUST THE NEUTRAL POSITION OF STEERING ANGLE SENSOR

CAUTION:

Always use CONSULT when adjusting the neutral position of steering angle sensor. (It cannot be adjusted other than with CONSULT.)

1. CHECK THE VEHICLE STATUS

Stop vehicle with front wheels in the straight-ahead position.

Does the vehicle stay in the straight-ahead position?

YES >> GO TO 2.

NO >> Steer the steering wheel to the straight-ahead position. Stop the vehicle.

2. ADJUST NEUTRAL POSITION OF STEERING ANGLE SENSOR

 With CONSULT

1. Turn the ignition switch ON.

CAUTION:

Never start engine.

2. Select "ABS", "WORK SUPPORT" and "ST ANGLE SENSOR ADJUSTMENT" in this order.

3. Select "START".

CAUTION:

Never touch steering wheel while adjusting steering angle sensor.

4. After approx. 10 seconds, select "END".

5. Turn ignition switch OFF, and then turn it ON again.

CAUTION:

Be sure to perform the operation above.

>> GO TO 3.

3. CHECK DATA MONITOR

 With CONSULT

1. The vehicle is either pointing straight ahead, or the vehicle needs to be moved. Stop when it is pointing straight ahead.

ADJUSTMENT OF STEERING ANGLE SENSOR NEUTRAL POSITION

< BASIC INSPECTION >

[WITH VDC]

2. Select "ABS", "DATA MONITOR", "ECU INPUT SIGNALS" and "STR ANGLE SIG" in the order. Check that the signal is within the specified value.

STR ANGLE SIG : $0 \pm 2.5^\circ$

Is the inspection result normal?

- YES >> GO TO 4.
NO >> GO TO 1.

4. ERASE SELF-DIAGNOSIS MEMORY

 With CONSULT

Erase self-diagnosis result of "ABS".

Are the memories erased?

- YES >> INSPECTION END
NO >> Check the items indicated by the self-diagnosis.

A
B
C
D
E
G
H
I
J
K
L
M
N
O
P

BRC

C1101, C1102, C1103, C1104 WHEEL SENSOR

< DTC/CIRCUIT DIAGNOSIS >

[WITH VDC]

DTC/CIRCUIT DIAGNOSIS

C1101, C1102, C1103, C1104 WHEEL SENSOR

DTC Logic

INFOID:000000009752912

DTC DETECTION LOGIC

DTC	Display Item	Malfunction detected condition	Possible causes
C1101	RR RH SENSOR-1	When an open circuit is detected in rear RH wheel sensor circuit.	<ul style="list-style-type: none">• Harness or connector• Wheel sensor• ABS actuator and electric unit (control unit)
C1102	RR LH SENSOR-1	When an open circuit is detected in rear LH wheel sensor circuit.	
C1103	FR RH SENSOR-1	When an open circuit is detected in front RH wheel sensor circuit.	
C1104	FR LH SENSOR-1	When an open circuit is detected in front LH wheel sensor circuit.	

DTC CONFIRMATION PROCEDURE

1. PRECONDITIONING

If "DTC CONFIRMATION PROCEDURE" has been previously conducted, always turn ignition switch OFF and wait at least 10 seconds before conducting the next test.

>> GO TO 2.

2. CHECK DTC DETECTION

④ With CONSULT

1. Start the engine.
2. Drive the vehicle at approx. 30 km/h (19 MPH) or more for approx. 1 minute.
3. Stop the vehicle.
4. Perform self-diagnosis for "ABS".

Is DTC "C1101", "C1102", "C1103" or "C1104" detected?

- YES >> Proceed to [BRC-64, "Diagnosis Procedure"](#).
NO >> INSPECTION END

Diagnosis Procedure

INFOID:000000009752913

CAUTION:

Never check the between wheel sensor harness connector terminals.

1. CHECK WHEEL SENSOR

1. Turn the ignition switch OFF.
2. Check the wheel sensor for damage.

Is the inspection result normal?

- YES >> GO TO 3.
NO >> GO TO 2.

2. REPLACE WHEEL SENSOR (1)

④ With CONSULT

1. Replace wheel sensor.
 - Front: Refer to [BRC-132, "FRONT WHEEL SENSOR : Removal and Installation"](#).
 - Rear: Refer to [BRC-135, "REAR WHEEL SENSOR : Removal and Installation"](#).
2. Erase self-diagnosis result for "ABS".
3. Turn the ignition switch OFF, and wait 10 seconds or more.
4. Start the engine.
5. Drive the vehicle at approx. 30 km/h (19 MPH) or more for approx. 1 minute.
6. Stop the vehicle.

C1101, C1102, C1103, C1104 WHEEL SENSOR

< DTC/CIRCUIT DIAGNOSIS >

[WITH VDC]

7. Perform self-diagnosis for "ABS".

Is DTC "C1101", "C1102", "C1103" or "C1104" detected?

YES >> GO TO 3.

NO >> INSPECTION END

3.CHECK CONNECTOR

1. Turn the ignition switch OFF.

2. Check the ABS actuator and electric unit (control unit) harness connector for disconnection or looseness.

3. Check the wheel sensor harness connector for disconnection or looseness.

Is the inspection result normal?

YES >> GO TO 5.

NO >> Repair or replace error-detected parts, securely lock the harness connector, and GO TO 4.

4.PERFORM SELF-DIAGNOSIS (1)

ⓂWith CONSULT

1. Erase self-diagnosis result for "ABS".

2. Turn the ignition switch OFF, and wait 10 seconds or more.

3. Start the engine.

4. Drive the vehicle at approx. 30 km/h (19 MPH) or more for approx. 1 minute.

5. Stop the vehicle.

6. Perform self-diagnosis for "ABS".

Is DTC "C1101", "C1102", "C1103" or "C1104" detected?

YES >> GO TO 5.

NO >> INSPECTION END

5.CHECK TERMINAL

1. Turn the ignition switch OFF.

2. Disconnect ABS actuator and electric unit (control unit) harness connector and then check the ABS actuator and electric unit (control unit) pin terminals for damage or loose connection with harness connector.

3. Disconnect wheel sensor harness connector and check the each wheel sensor pin terminals for damage or loose connection with harness connector.

Is the inspection result normal?

YES >> GO TO 7.

NO >> Repair or replace error-detected parts and GO TO 6.

6.PERFORM SELF-DIAGNOSIS (2)

ⓂWith CONSULT

1. Connect ABS actuator and electric unit (control unit) harness connector.

2. Connect wheel sensor harness connector.

3. Erase self-diagnosis result for "ABS".

4. Turn the ignition switch OFF, and wait 10 seconds or more.

5. Start the engine.

6. Drive the vehicle at approx. 30 km/h (19 MPH) or more for approx. 1 minute.

7. Stop the vehicle.

8. Perform self-diagnosis for "ABS".

Is DTC "C1101", "C1102", "C1103" or "C1104" detected?

YES >> GO TO 7.

NO >> INSPECTION END

7.CHECK WHEEL SENSOR HARNESS

1. Turn the ignition switch OFF.

2. Disconnect ABS actuator and electric unit (control unit) harness connector.

3. Disconnect wheel sensor harness connector.

4. Check the continuity between ABS actuator and electric unit (control unit) harness connector and wheel sensor harness connector. (Check the continuity when steering wheel is steered to RH and LH, or center harness in wheel housing is moved.)

A

B

C

D

E

BRC

G

H

I

J

K

L

M

N

O

P

C1101, C1102, C1103, C1104 WHEEL SENSOR

< DTC/CIRCUIT DIAGNOSIS >

[WITH VDC]

Measurement connector and terminal for power supply circuit

ABS actuator and electric unit (control unit)		Wheel sensor		Continuity
Connector	Terminal	Connector	Terminal	
E35	23	E22 (Front LH wheel)	1	Existed
	21	E39 (Front RH wheel)		
	26	B44 (Rear LH wheel)		
	11	B41 ^{*1} (Rear RH wheel) B45 ^{*2} (Rear RH wheel)		

*1: 2WD

*2: AWD

Measurement connector and terminal for signal circuit

ABS actuator and electric unit (control unit)		Wheel sensor		Continuity
Connector	Terminal	Connector	Terminal	
E35	27	E22 (Front LH wheel)	2	Existed
	12	E39 (Front RH wheel)		
	30	B44 (Rear LH wheel)		
	15	B41 ^{*1} (Rear RH wheel) B45 ^{*2} (Rear RH wheel)		

*1: 2WD

*2: AWD

Is the inspection result normal?

YES >> GO TO 9.

NO >> Repair or replace error-detected parts and GO TO 8.

8. PERFORM SELF-DIAGNOSIS (3)

 With CONSULT

1. Connect ABS actuator and electric unit (control unit) harness connector.
2. Connect wheel sensor harness connector.
3. Erase self-diagnosis result for "ABS".
4. Turn the ignition switch OFF, and wait 10 seconds or more.
5. Start the engine.
6. Drive the vehicle at approx. 30 km/h (19 MPH) or more for approx. 1 minute.
7. Stop the vehicle.
8. Perform self-diagnosis for "ABS".

Is DTC "C1101", "C1102", "C1103" or "C1104" detected?

YES >> GO TO 9.

NO >> INSPECTION END

9. REPLACE WHEEL SENSOR (2)

 With CONSULT

1. Replace wheel sensor.
 - Front: Refer to [BRC-132, "FRONT WHEEL SENSOR : Removal and Installation"](#).
 - Rear: Refer to [BRC-135, "REAR WHEEL SENSOR : Removal and Installation"](#).
2. Erase self-diagnosis result for "ABS".
3. Turn the ignition switch OFF, and wait 10 seconds or more.
4. Start the engine.
5. Drive the vehicle at approx. 30 km/h (19 MPH) or more for approx. 1 minute.
6. Stop the vehicle.
7. Perform self-diagnosis for "ABS".

Is DTC "C1101", "C1102", "C1103" or "C1104" detected?

YES >> Replace ABS actuator and electric unit (control unit). Refer to [BRC-138, "Removal and Installation"](#).

NO >> INSPECTION END

C1105, C1106, C1107, C1108 WHEEL SENSOR

< DTC/CIRCUIT DIAGNOSIS >

[WITH VDC]

C1105, C1106, C1107, C1108 WHEEL SENSOR

DTC Logic

INFOID:000000009752914

DTC DETECTION LOGIC

DTC	Display Item	Malfunction detected condition	Possible causes
C1105	RR RH SENSOR-2	<ul style="list-style-type: none"> • When a short circuit is detected in rear RH wheel sensor circuit. • When power supply voltage of rear RH wheel sensor is in following state. <ul style="list-style-type: none"> - Rear RH wheel sensor power supply voltage: 7.5 V \geq Rear RH wheel sensor power supply voltage - Rear RH wheel sensor power supply voltage: 16 V \leq Rear RH wheel sensor power supply voltage • When distance between rear RH wheel sensor and rear RH wheel sensor rotor is large. • When installation of rear RH wheel sensor or rear RH wheel sensor rotor is not normal. 	<ul style="list-style-type: none"> • Harness or connector • Wheel sensor • ABS actuator and electric unit (control unit) • Sensor rotor • Tire
C1106	RR LH SENSOR-2	<ul style="list-style-type: none"> • When a short circuit is detected in rear LH wheel sensor circuit. • When power supply voltage of rear LH wheel sensor is in following state. <ul style="list-style-type: none"> - Rear LH wheel sensor power supply voltage: 7.5 V \geq Rear LH wheel sensor power supply voltage - Rear LH wheel sensor power supply voltage: 16 V \leq Rear LH wheel sensor power supply voltage • When distance between rear LH wheel sensor and rear LH wheel sensor rotor is large. • When installation of rear LH wheel sensor or rear LH wheel sensor rotor is not normal. 	
C1107	FR RH SENSOR-2	<ul style="list-style-type: none"> • When a short circuit is detected in front RH wheel sensor circuit. • When power supply voltage of front RH wheel sensor is in following state. <ul style="list-style-type: none"> - Front RH wheel sensor power supply voltage: 7.5 V \geq Front RH wheel sensor power supply voltage - Front RH wheel sensor power supply voltage: 16 V \leq Front RH wheel sensor power supply voltage • When distance between front RH wheel sensor and front RH wheel sensor rotor is large. • When installation of front RH wheel sensor or front RH wheel sensor rotor is not normal. 	
C1108	FR LH SENSOR-2	<ul style="list-style-type: none"> • When a short circuit is detected in front LH wheel sensor circuit. • When power supply voltage of front LH wheel sensor is in following state. <ul style="list-style-type: none"> - Front LH wheel sensor power supply voltage: 7.5 V \geq Front LH wheel sensor power supply voltage - Front LH wheel sensor power supply voltage: 16 V \leq Front LH wheel sensor power supply voltage • When distance between front LH wheel sensor and front LH wheel sensor rotor is large. • When installation of front LH wheel sensor or front LH wheel sensor rotor is not normal. 	

A
B
C
D
E
BRC
G
H
I
J
K
L
M
N
O
P

DTC CONFIRMATION PROCEDURE

1. PRECONDITIONING

If "DTC CONFIRMATION PROCEDURE" has been previously conducted, always turn ignition switch OFF and wait at least 10 seconds before conducting the next test.

>> GO TO 2.

C1105, C1106, C1107, C1108 WHEEL SENSOR

< DTC/CIRCUIT DIAGNOSIS >

[WITH VDC]

2. CHECK DTC DETECTION

Ⓜ With CONSULT

1. Start the engine.
2. Drive the vehicle at approx. 30 km/h (19 MPH) or more for approx. 1 minute.
3. Stop the vehicle.
4. Perform self-diagnosis for "ABS".

Is DTC "C1105", "C1106", "C1107" or "C1108" detected?

- YES >> Proceed to [BRC-68, "Diagnosis Procedure"](#).
NO >> INSPECTION END

Diagnosis Procedure

INFOID:000000009752915

CAUTION:

Never check the between wheel sensor harness connector terminals.

1. CHECK ABS ACTUATOR AND ELECTRIC UNIT (CONTROL UNIT) POWER SUPPLY SYSTEM

Check the ABS actuator and electric unit (control unit) power supply system. Refer to [BRC-114, "Diagnosis Procedure"](#).

Is the inspection result normal?

- YES >> GO TO 2.
NO >> Repair or replace error-detected parts.

2. CHECK TIRE

1. Turn the ignition switch OFF.
2. Check the tire air pressure, wear and size. Refer to [WT-54, "Tire Air Pressure"](#).

Is the inspection result normal?

- YES >> GO TO 5.
NO >> Adjust air pressure or replace tire and GO TO 3.

3. CHECK DATA MONITOR (1)

Ⓜ With CONSULT

1. Erase self-diagnosis result for "ABS".
2. Turn the ignition switch OFF, and wait 10 seconds or more.
3. Start the engine.
4. Select "ABS" and "DATA MONITOR", check the "FR LH SENSOR", "FR RH SENSOR", "RR LH SENSOR" and "RR RH SENSOR".

NOTE:

Set the "DATA MONITOR" recording speed to "10 msec".

5. Read a value (wheel speed) of both normal wheel sensors and error-detecting wheel sensor.

Regarding the deference at 30 km/h (19 MPH) between the wheel speed detected by the error detecting wheel sensor and the maximum/minimum wheel speed detected by the normal wheel sensors, is the difference within 5%, respectively?

- YES >> GO TO 4.
NO >> GO TO 5.

4. PERFORM SELF-DIAGNOSIS (1)

Ⓜ With CONSULT

1. Drive the vehicle at approx. 30 km/h (19 MPH) or more for approx. 1 minute.
2. Stop the vehicle.
3. Perform self-diagnosis for "ABS".

Is DTC "C1105", "C1106", "C1107" or "C1108" detected?

- YES >> GO TO 5.
NO >> INSPECTION END

5. CHECK WHEEL SENSOR

1. Turn the ignition switch OFF.
2. Check the wheel sensor for damage.

C1105, C1106, C1107, C1108 WHEEL SENSOR

[WITH VDC]

< DTC/CIRCUIT DIAGNOSIS >

- Remove dust and foreign matter adhered to the sensor rotor with a vacuum dust collector through the wheel sensor mounting hole.

CAUTION:

Install wheel sensor with no backlash and float, and tighten the mounting bolt to the specified torque.

- Front: Refer to [BRC-132, "FRONT WHEEL SENSOR : Exploded View"](#).
- Rear: Refer to [BRC-133, "REAR WHEEL SENSOR : Exploded View"](#).

Is the inspection result normal?

YES >> GO TO 8.

NO >> GO TO 6.

6. REPLACE WHEEL SENSOR (1)

Ⓜ With CONSULT

- Replace wheel sensor.
 - Front: Refer to [BRC-132, "FRONT WHEEL SENSOR : Removal and Installation"](#).
 - Rear: Refer to [BRC-135, "REAR WHEEL SENSOR : Removal and Installation"](#).
- Erase self-diagnosis result for "ABS".
- Turn the ignition switch OFF, and wait 10 seconds or more.
- Start the engine.
- Select "ABS" and "DATA MONITOR", check the "FR LH SENSOR", "FR RH SENSOR", "RR LH SENSOR" and "RR RH SENSOR".

NOTE:

Set the "DATA MONITOR" recording speed to "10 msec".

- Read a value (wheel speed) of both normal wheel sensors and error-detecting wheel sensor.

Regarding the deference at 30 km/h (19 MPH) between the wheel speed detected by the error detecting wheel sensor and the maximum/minimum wheel speed detected by the normal wheel sensors, is the difference within 5%. respectively?

YES >> GO TO 7.

NO >> GO TO 19.

7. PERFORM SELF-DIAGNOSIS (2)

Ⓜ With CONSULT

- Drive the vehicle at approx. 30 km/h (19 MPH) or more for approx. 1 minute.
- Stop the vehicle.
- Perform self-diagnosis for "ABS".

Is DTC "C1105", "C1106", "C1107" or "C1108" detected?

YES >> GO TO 19.

NO >> INSPECTION END

8. CHECK CONNECTOR

- Turn the ignition switch OFF.
- Check the ABS actuator and electric unit (control unit) harness connector for disconnection or looseness.
- Check the wheel sensor harness connector for disconnection or looseness.

Is the inspection result normal?

YES >> GO TO 11.

NO >> Repair or replace error-detected parts, securely lock the harness connector, and GO TO 9.

9. CHECK DATA MONITOR (2)

Ⓜ With CONSULT

- Erase self-diagnosis result for "ABS".
- Turn the ignition switch OFF, and wait 10 seconds or more.
- Start the engine.
- Select "ABS" and "DATA MONITOR", check the "FR LH SENSOR", "FR RH SENSOR", "RR LH SENSOR" and "RR RH SENSOR".

NOTE:

Set the "DATA MONITOR" recording speed to "10 msec".

- Read a value (wheel speed) of both normal wheel sensors and error-detecting wheel sensor.

C1105, C1106, C1107, C1108 WHEEL SENSOR

[WITH VDC]

< DTC/CIRCUIT DIAGNOSIS >

Regarding the deference at 30 km/h (19 MPH) between the wheel speed detected by the error detecting wheel sensor and the maximum/minimum wheel speed detected by the normal wheel sensors, is the difference within 5%. respectively?

- YES >> GO TO 10.
- NO >> GO TO 11.

10.PERFORM SELF-DIAGNOSIS (3)

ⓂWith CONSULT

1. Drive the vehicle at approx. 30 km/h (19 MPH) or more for approx. 1 minute.
2. Stop the vehicle.
3. Perform self-diagnosis for "ABS".

Is DTC "C1105", "C1106", "C1107" or "C1108" detected?

- YES >> GO TO 11.
- NO >> INSPECTION END

11.CHECK TERMINAL

1. Turn the ignition switch OFF.
2. Disconnect ABS actuator and electric unit (control unit) harness connector and then check the ABS actuator and electric unit (control unit) pin terminals for damage or loose connection with harness connector.
3. Disconnect wheel sensor harness connector and check the each wheel sensor pin terminals for damage or loose connection with harness connector.

Is the inspection result normal?

- YES >> GO TO 14.
- NO >> Repair or replace error-detected parts and GO TO 12.

12.CHECK DATA MONITOR (3)

ⓂWith CONSULT

1. Connect ABS actuator and electric unit (control unit) harness connector.
2. Connect wheel sensor harness connector.
3. Erase self-diagnosis result for "ABS".
4. Turn the ignition switch OFF, and wait 10 seconds or more.
5. Start the engine.
6. Select "ABS" and "DATA MONITOR", check the "FR LH SENSOR", "FR RH SENSOR", "RR LH SENSOR" and "RR RH SENSOR".

NOTE:

Set the "DATA MONITOR" recording speed to "10 msec".

7. Read a value (wheel speed) of both normal wheel sensors and error-detecting wheel sensor.

Regarding the deference at 30 km/h (19 MPH) between the wheel speed detected by the error detecting wheel sensor and the maximum/minimum wheel speed detected by the normal wheel sensors, is the difference within 5%. respectively?

- YES >> GO TO 13.
- NO >> GO TO 14.

13.PERFORM SELF-DIAGNOSIS (4)

ⓂWith CONSULT

1. Drive the vehicle at approx. 30 km/h (19 MPH) or more for approx. 1 minute.
2. Stop the vehicle.
3. Perform self-diagnosis for "ABS".

Is DTC "C1105", "C1106", "C1107" or "C1108" detected?

- YES >> GO TO 14.
- NO >> INSPECTION END

14.CHECK WHEEL SENSOR HARNESS

1. Turn the ignition switch OFF.
2. Disconnect ABS actuator and electric unit (control unit) harness connector.
3. Disconnect wheel sensor harness connector.
4. Check the continuity between ABS actuator and electric unit (control unit) harness connector and the ground.

C1105, C1106, C1107, C1108 WHEEL SENSOR

< DTC/CIRCUIT DIAGNOSIS >

[WITH VDC]

ABS actuator and electric unit (control unit)		—	Continuity
Connector	Terminal		
E35	23, 27	Ground	Not existed
	21, 12		
	26, 30		
	11, 15		

Is the inspection result normal?

YES >> GO TO 15.

NO >> Repair or replace error-detected parts and GO TO 15.

15. CHECK DATA MONITOR (4)

Ⓜ With CONSULT

1. Connect ABS actuator and electric unit (control unit) harness connector.
2. Connect wheel sensor harness connector.
3. Erase self-diagnosis result for "ABS".
4. Turn the ignition switch OFF, and wait 10 seconds or more.
5. Start the engine.
6. Select "ABS" and "DATA MONITOR", check the "FR LH SENSOR", "FR RH SENSOR", "RR LH SENSOR" and "RR RH SENSOR".

NOTE:

Set the "DATA MONITOR" recording speed to "10 msec".

7. Read a value (wheel speed) of both normal wheel sensors and error-detecting wheel sensor.

Regarding the deference at 30 km/h (19 MPH) between the wheel speed detected by the error detecting wheel sensor and the maximum/minimum wheel speed detected by the normal wheel sensors, is the difference within 5%, respectively?

YES >> GO TO 16.

NO >> GO TO 17.

16. PERFORM SELF-DIAGNOSIS (5)

Ⓜ With CONSULT

1. Drive the vehicle at approx. 30 km/h (19 MPH) or more for approx. 1 minute.
2. Stop the vehicle.
3. Perform self-diagnosis for "ABS".

Is DTC "C1105", "C1106", "C1107" or "C1108" detected?

YES >> GO TO 17.

NO >> INSPECTION END

17. REPLACE WHEEL SENSOR

Ⓜ With CONSULT

1. Replace wheel sensor.
 - Front: Refer to [BRC-132, "FRONT WHEEL SENSOR : Removal and Installation"](#).
 - Rear: Refer to [BRC-135, "REAR WHEEL SENSOR : Removal and Installation"](#).
2. Erase self-diagnosis result for "ABS".
3. Turn the ignition switch OFF, and wait 10 seconds or more.
4. Start the engine.
5. Select "ABS" and "DATA MONITOR", check the "FR LH SENSOR", "FR RH SENSOR", "RR LH SENSOR" and "RR RH SENSOR".

NOTE:

Set the "DATA MONITOR" recording speed to "10 msec".

6. Read a value (wheel speed) of both normal wheel sensors and error-detecting wheel sensor.

Regarding the deference at 30 km/h (19 MPH) between the wheel speed detected by the error detecting wheel sensor and the maximum/minimum wheel speed detected by the normal wheel sensors, is the difference within 5%, respectively?

YES >> GO TO 18.

NO >> GO TO 19.

C1105, C1106, C1107, C1108 WHEEL SENSOR

< DTC/CIRCUIT DIAGNOSIS >

[WITH VDC]

18. PERFORM SELF-DIAGNOSIS (6)

Ⓜ With CONSULT

1. Drive the vehicle at approx. 30 km/h (19 MPH) or more for approx. 1 minute.
2. Stop the vehicle.
3. Perform self-diagnosis for "ABS".

Is DTC "C1105", "C1106", "C1107" or "C1108" detected?

YES >> GO TO 19.

NO >> INSPECTION END

19. REPLACE SENSOR ROTOR (2)

Ⓜ With CONSULT

1. Replace sensor rotor.
 - Front: Refer to [BRC-132. "FRONT WHEEL SENSOR : Removal and Installation"](#).
 - Rear: Refer to [BRC-135. "REAR WHEEL SENSOR : Removal and Installation"](#).
2. Erase self-diagnosis result for "ABS".
3. Turn the ignition switch OFF, and wait 10 seconds or more.
4. Start the engine.
5. Drive the vehicle at approx. 30 km/h (19 MPH) or more for approx. 1 minute.
6. Stop the vehicle.
7. Perform self-diagnosis for "ABS".

Is DTC "C1105", "C1106", "C1107" or "C1108" detected?

YES >> Replace ABS actuator and electric unit (control unit). Refer to [BRC-138. "Removal and Installation"](#).

NO >> INSPECTION END

C1109 POWER AND GROUND SYSTEM

< DTC/CIRCUIT DIAGNOSIS >

[WITH VDC]

C1109 POWER AND GROUND SYSTEM

DTC Logic

INFOID:000000009752916

DTC DETECTION LOGIC

DTC	Display Item	Malfunction detected condition	Possible causes
C1109	BATTERY VOLTAGE [ABNORMAL]	When ignition power supply voltage is in following state. <ul style="list-style-type: none">Ignition power supply voltage: $10\text{ V} \geq$ Ignition power supply voltage.Ignition power supply voltage: $16\text{ V} \leq$ Ignition power supply voltage.	<ul style="list-style-type: none">Harness or connectorABS actuator and electric unit (control unit)FuseIgnition power supply systemBattery

DTC CONFIRMATION PROCEDURE

1. PRECONDITIONING

If "DTC CONFIRMATION PROCEDURE" has been previously conducted, always turn ignition switch OFF and wait at least 10 seconds before conducting the next test.

>> GO TO 2.

2. CHECK DTC DETECTION

Ⓜ With CONSULT

- Turn the ignition switch OFF to ON.
- Perform self-diagnosis for "ABS"

Is DTC "C1109" detected?

- YES >> Proceed to [BRC-73. "Diagnosis Procedure"](#).
NO >> INSPECTION END

Diagnosis Procedure

INFOID:000000009752917

1. CHECK CONNECTOR

- Turn the ignition switch OFF.
- Check the ABS actuator and electric unit (control unit) harness connector for disconnection or looseness.

Is the inspection result normal?

- YES >> GO TO 3.
NO >> Repair or replace error-detected parts, securely lock the harness connector, and GO TO 2.

2. PERFORM SELF-DIAGNOSIS

Perform self-diagnosis for "ABS" again.

Is DTC "C1109" detected?

- YES >> GO TO 3.
NO >> INSPECTION END

3. CHECK ABS ACTUATOR AND ELECTRIC UNIT (CONTROL UNIT) IGNITION POWER SUPPLY

- Turn the ignition switch OFF.
- Disconnect ABS actuator and electric unit (control unit) harness connector.
- Check the voltage between ABS actuator and electric unit (control unit) harness connector and ground.

ABS actuator and electric unit (control unit)		—	Voltage
Connector	Terminal		
E35	16	Ground	Approx. 0 V

- Turn the ignition switch ON.

CAUTION:

Never start engine.

- Check the voltage between ABS actuator and electric unit (control unit) harness connector and ground.

C1109 POWER AND GROUND SYSTEM

[WITH VDC]

< DTC/CIRCUIT DIAGNOSIS >

ABS actuator and electric unit (control unit)		—	Voltage
Connector	Terminal		
E35	16	Ground	10 – 16 V

Is the inspection result normal?

- YES >> GO TO 5.
NO >> GO TO 4.

4.CHECK ABS ACTUATOR AND ELECTRIC UNIT (CONTROL UNIT) IGNITION POWER SUPPLY CIRCUIT

1. Turn the ignition switch OFF.
2. Check the 10A fuse (#57).
3. Disconnect IPDM E/R harness connector.
4. Check the continuity between ABS actuator and electric unit (control unit) harness connector and IPDM E/R harness connector.

ABS actuator and electric unit (control unit)		IPDM E/R		Continuity
Connector	Terminal	Connector	Terminal	
E35	16	E15	59	Existed

5. Check the continuity between ABS actuator and electric unit (control unit) harness connector and the ground.

ABS actuator and electric unit (control unit)		—	Continuity
Connector	Terminal		
E35	16	Ground	Not existed

Is the inspection result normal?

- YES >> Perform trouble diagnosis for ignition power supply. Refer to [PG-41, "Wiring Diagram - IGNITION POWER SUPPLY -"](#).
NO >> Repair or replace error-detected parts.

5.CHECK ABS ACTUATOR AND ELECTRIC UNIT (CONTROL UNIT) GROUND CIRCUIT

1. Turn the ignition switch OFF.
2. Check the continuity between ABS actuator and electric unit (control unit) harness connector and ground.

ABS actuator and electric unit (control unit)		—	Continuity
Connector	Terminal		
E35	3	Ground	Existed
	4		

Is the inspection result normal?

- YES >> GO TO 6.
NO >> Repair or replace error-detected parts.

6.CHECK TERMINAL

- Check the ABS actuator and electric unit (control unit) pin terminals for damage or loose connection with harness connector.
- Check the IPDM E/R pin terminals for damage or loose connection with harness connector.

Is the inspection result normal?

- YES >> Replace ABS actuator and electric unit (control unit). Refer to [BRC-138, "Removal and Installation"](#).
NO >> Repair or replace error-detected parts.

C1110, C1170 ABS ACTUATOR AND ELECTRIC UNIT (CONTROL UNIT)

[WITH VDC]

< DTC/CIRCUIT DIAGNOSIS >

C1110, C1170 ABS ACTUATOR AND ELECTRIC UNIT (CONTROL UNIT)

DTC Logic

INFOID:000000009752918

DTC DETECTION LOGIC

DTC	Display Item	Malfunction detected condition	Possible causes
C1110	CONTROLLER FAILURE	When there is an internal malfunction in the ABS actuator and electric unit (control unit).	ABS actuator and electric unit (control unit)
C1170	VARIANT CODING	When the information in ABS actuator and electric unit (control unit) is not the same.	

DTC CONFIRMATION PROCEDURE

1. PRECONDITIONING

If "DTC CONFIRMATION PROCEDURE" has been previously conducted, always turn ignition switch OFF and wait at least 10 seconds before conducting the next test.

>> GO TO 2.

2. CHECK DTC DETECTION

Ⓜ With CONSULT

1. Turn the ignition switch OFF to ON.
2. Perform self-diagnosis for "ABS".

Is DTC "C1110" or "C1170" detected?

- YES >> Proceed to [BRC-75, "Diagnosis Procedure"](#).
NO >> INSPECTION END

Diagnosis Procedure

INFOID:000000009752919

1. CHECK SELF-DIAGNOSIS RESULTS

Replace ABS actuator and electric unit (control unit) even if other display than "C1110" or "C1170" is displayed in self-diagnosis for "ABS".

>> Replace ABS actuator and electric unit (control unit). Refer to [BRC-138, "Removal and Installation"](#).

C1111 ABS MOTOR, MOTOR RELAY SYSTEM

< DTC/CIRCUIT DIAGNOSIS >

[WITH VDC]

C1111 ABS MOTOR, MOTOR RELAY SYSTEM

DTC Logic

INFOID:000000009752920

DTC DETECTION LOGIC

DTC	Display Item	Malfunction detected condition	Possible causes
C1111	PUMP MOTOR	When a malfunction is detected in motor or motor relay.	<ul style="list-style-type: none">• Harness or connector• ABS actuator and electric unit (control unit)• Fusible link• Battery power supply system

DTC CONFIRMATION PROCEDURE

1. PRECONDITIONING

If "DTC CONFIRMATION PROCEDURE" has been previously conducted, always turn ignition switch OFF and wait at least 10 seconds before conducting the next test.

>> GO TO 2.

2. CHECK DTC DETECTION

Ⓟ With CONSULT

1. Turn the ignition switch OFF to ON.
2. Perform self-diagnosis for "ABS".

Is DTC "C1111" detected?

YES >> Proceed to [BRC-76. "Diagnosis Procedure"](#).

NO >> INSPECTION END

Diagnosis Procedure

INFOID:000000009752921

1. CHECK CONNECTOR

1. Turn the ignition switch OFF.
2. Check the ABS actuator and electric unit (control unit) harness connector for disconnection or looseness.

Is the inspection result normal?

YES >> GO TO 3.

NO >> Repair or replace error-detected parts, securely lock the harness connector, and GO TO 2.

2. PERFORM SELF-DIAGNOSIS

Perform self-diagnosis for "ABS" again.

Is DTC "C1111" detected?

YES >> GO TO 3.

NO >> INSPECTION END

3. CHECK ABS MOTOR AND MOTOR RELAY POWER SUPPLY

1. Turn the ignition switch OFF.
2. Disconnect ABS actuator and electric unit (control unit) harness connector.
3. Check the voltage between ABS actuator and electric unit (control unit) harness connector and ground.

ABS actuator and electric unit (control unit)		—	Voltage
Connector	Terminal		
E35	1	Ground	10 – 16 V

4. Turn the ignition switch ON.

CAUTION:

Never start engine.

5. Check the voltage between ABS actuator and electric unit (control unit) harness connector and ground.

C1111 ABS MOTOR, MOTOR RELAY SYSTEM

[WITH VDC]

< DTC/CIRCUIT DIAGNOSIS >

ABS actuator and electric unit (control unit)		—	Voltage
Connector	Terminal		
E35	1	Ground	10 – 16 V

Is the inspection result normal?

YES >> GO TO 5.

NO >> GO TO 4.

4. CHECK ABS MOTOR AND MOTOR RELAY POWER SUPPLY CIRCUIT

1. Turn the ignition switch OFF.
2. Check the 30A fusible link (K).
3. Check the continuity and short circuit between ABS actuator and electric unit (control unit) harness connector terminal (1) and 30A fusible link (K).

Is the inspection result normal?

YES >> Perform trouble diagnosis for battery power supply. Refer to [PG-11, "Wiring Diagram - BATTERY POWER SUPPLY -"](#).

NO >> Repair or replace error-detected parts.

5. CHECK ABS ACTUATOR AND ELECTRIC UNIT (CONTROL UNIT) GROUND CIRCUIT

1. Turn the ignition switch OFF.
2. Check the continuity between ABS actuator and electric unit (control unit) harness connector and the ground.

ABS actuator and electric unit (control unit)		—	Continuity
Connector	Terminal		
E35	3	Ground	Existed
	4		

Is the inspection result normal?

YES >> GO TO 6.

NO >> Repair or replace error-detected parts.

6. CHECK TERMINAL

Check the ABS actuator and electric unit (control unit) pin terminals for damage or loose connection with harness connector.

Is the inspection result normal?

YES >> Replace ABS actuator and electric unit (control unit). Refer to [BRC-138, "Removal and Installation"](#).

NO >> Repair or replace error-detected parts.

C1113, C1145, C1146 YAW RATE/SIDE/DECEL G SENSOR

< DTC/CIRCUIT DIAGNOSIS >

[WITH VDC]

C1113, C1145, C1146 YAW RATE/SIDE/DECEL G SENSOR

DTC Logic

INFOID:000000009752922

DTC DETECTION LOGIC

DTC	Display item	Malfunction detected condition	Possible cause
C1113	G SENSOR	When a malfunction is detected in decel G signal, or signal line of yaw rate/side/decel G sensor is open or shorted.	<ul style="list-style-type: none">• Harness or connector• Yaw rate/side/decel G sensor• ABS actuator and electric unit (control unit)
C1145	YAW RATE SENSOR	When a malfunction is detected in yaw rate signal, or signal line of yaw rate/side/decel G sensor is open or shorted.	
C1146	SIDE G-SEN CIRCUIT	When a malfunction is detected in side G signal, or signal line of yaw rate/side/decel G sensor is open or shorted.	

DTC CONFIRMATION PROCEDURE

1. PRECONDITIONING

If "DTC CONFIRMATION PROCEDURE" has been previously conducted, always turn ignition switch OFF and wait at least 10 seconds before conducting the next test.

>> GO TO 2.

2. CHECK DTC DETECTION

Ⓟ With CONSULT

1. Turn the ignition switch OFF to ON.
2. Perform self-diagnosis for "ABS".

Is DTC "C1113" "C1145" or "C1146" detected?

- YES >> Proceed to [BRC-78, "Diagnosis Procedure"](#).
NO >> INSPECTION END

Diagnosis Procedure

INFOID:000000009752923

1. CHECK ABS ACTUATOR AND ELECTRIC UNIT (CONTROL UNIT) POWER SUPPLY SYSTEM

Check the ABS actuator and electric unit (control unit) power supply system. Refer to [BRC-114, "Diagnosis Procedure"](#).

Is the inspection result normal?

- YES >> GO TO 2.
NO >> Repair or replace error-detected parts.

2. CHECK CONNECTOR

1. Turn ignition switch OFF.
2. Check the ABS actuator and electric unit (control unit) harness connector for disconnection or looseness.
3. Check the yaw rate/side/decel G sensor harness connector for disconnection or looseness.

Is the inspection result normal?

- YES >> GO TO 4.
NO >> Repair or replace error-detected parts, securely lock the harness connector, and GO TO 3.

3. PERFORM SELF-DIAGNOSIS

Perform self-diagnosis for "ABS" again.

Is DTC "C1113", "C1145" or "C1146" detected?

- YES >> GO TO 4.
NO >> INSPECTION END

4. CHECK YAW RATE/SIDE/DECEL G SENSOR POWER SUPPLY CIRCUIT

1. Turn ignition switch OFF.

C1113, C1145, C1146 YAW RATE/SIDE/DECEL G SENSOR

< DTC/CIRCUIT DIAGNOSIS >

[WITH VDC]

2. Disconnect ABS actuator and electric unit (control unit) harness connector.
3. Disconnect yaw rate/side/decel G sensor harness connector.
4. Check the continuity between yaw rate/side/decel G sensor harness connector and ABS actuator and electric unit (control unit) harness connector.

ABS actuator and electric unit (control unit)		Yaw rate/side/decel G sensor		Continuity
Connector	Terminal	Connector	Terminal	
E35	13	B38	4	Existed

Is the inspection result normal?

YES >> GO TO 5.

NO >> Repair or replace error-detected parts.

5. CHECK YAW RATE/SIDE/DECEL G SENSOR GROUND CIRCUIT

Check the continuity between yaw rate/side/decel G sensor harness connector and ABS actuator and electric unit (control unit) harness connector.

ABS actuator and electric unit (control unit)		Yaw rate/side/decel G sensor		Continuity
Connector	Terminal	Connector	Terminal	
E35	28	B38	2	Existed

Is the inspection result normal?

YES >> GO TO 6.

NO >> Repair or replace error-detected parts.

6. CHECK YAW RATE/SIDE/DECEL G SENSOR SIGNAL CIRCUIT

Check the continuity between yaw rate/side/decel G sensor harness connector and ABS actuator and electric unit (control unit) harness connector.

ABS actuator and electric unit (control unit)		Yaw rate/side/decel G sensor		Continuity
Connector	Terminal	Connector	Terminal	
E35	14	B38	5	Existed
	29		6	

Is the inspection result normal?

YES >> GO TO 7.

NO >> Repair or replace error-detected parts.

7. CHECK YAW RATE/SIDE/DECEL G SENSOR CIRCUIT

Check the continuity between each terminals of yaw rate/side/decel G sensor harness connector.

Yaw rate/side/decel G sensor		Continuity
Connector	Terminal	
B38	2 - 4	Not existed
	2 - 5	
	2 - 6	
	4 - 5	
	4 - 6	
	5 - 6	

Is the inspection result normal?

YES >> GO TO 8.

NO >> Repair or replace error-detected parts.

8. CHECK YAW RATE/SIDE/DECEL G SENSOR 1

Ⓜ With CONSULT

1. Connect yaw rate/side/decel G sensor harness connector.

C1113, C1145, C1146 YAW RATE/SIDE/DECEL G SENSOR

< DTC/CIRCUIT DIAGNOSIS >

[WITH VDC]

2. Connect ABS actuator and electric unit (control unit) harness connector.
3. Turn the ignition switch ON.
4. Select "ABS", "DATA MONITOR" and "DECEL G-SEN" in order.
5. Move yaw rate/side/decel G sensor as shown in the figure to check the output of before and after moving the sensor.

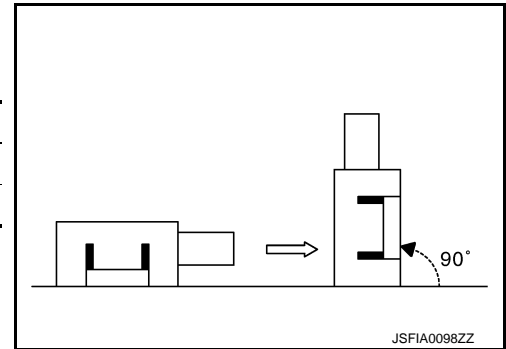

Condition	DATA MONITOR
Horizontal	Approx. 0 G
Vertical	Approx. +1 G

Is the inspection result normal?

- YES >> GO TO 9.
 NO >> Replace yaw rate/side/decel G sensor. Refer to [BRC-140, "Removal and Installation"](#).

9. CHECK YAW RATE/SIDE/DECEL G SENSOR 2

1. Turn ignition switch OFF.
2. Connect following terminals between yaw rate/side/decel G sensor and harness connector.

Yaw rate/side/decel G sensor	Harness connector	
	Connector	Terminal
2	B38	2
4		4
5		5
6		6

3. Turn ignition switch ON.
CAUTION:
Never start the engine.
4. Check the voltage between yaw rate/side/decel G sensor harness connector terminals.
CAUTION:
Never short out the terminals while measuring voltages.

Yaw rate/side/decel G sensor		Voltage
connector	Terminal	
B38	5 - 2	2.5 - 4.5 V
	6 - 2	0.5 - 2.5 V

Is the inspection result normal?

- YES >> Replace ABS actuator end electric unit (control unit). Refer to [BRC-138, "Removal and Installation"](#).
 NO >> Replace yaw rate/side/decel G sensor. Refer to [BRC-140, "Removal and Installation"](#).

C1115 WHEEL SENSOR

< DTC/CIRCUIT DIAGNOSIS >

[WITH VDC]

C1115 WHEEL SENSOR

DTC Logic

INFOID:000000009752924

DTC DETECTION LOGIC

DTC	Display Item	Malfunction detected condition	Possible causes
C1115	ABS SENSOR [ABNORMAL SIGNAL]	When difference in wheel speed between any wheel and others is detected the vehicle is driven, because of installation of other tires than specified.	<ul style="list-style-type: none">• Harness or connector• Wheel sensor• Sensor rotor• ABS actuator and electric unit (control unit)• Tire

DTC CONFIRMATION PROCEDURE

1. PRECONDITIONING

If "DTC CONFIRMATION PROCEDURE" has been previously conducted, always turn ignition switch OFF and wait at least 10 seconds before conducting the next test.

>> GO TO 2.

2. CHECK DTC DETECTION

Ⓜ With CONSULT

1. Start the engine.
2. Drive the vehicle at approx. 30 km/h (19 MPH) or more for approx. 1 minute.
3. Stop the vehicle.
4. Perform self-diagnosis for "ABS".

Is DTC "C1115" detected?

- YES >> Proceed to [BRC-81, "Diagnosis Procedure"](#).
NO >> INSPECTION END

Diagnosis Procedure

INFOID:000000009752925

CAUTION:

Never check the between wheel sensor harness connector terminals.

1. CHECK ABS ACTUATOR AND ELECTRIC UNIT (CONTROL UNIT) POWER SUPPLY SYSTEM

Check the ABS actuator and electric unit (control unit) power supply system. Refer to [BRC-114, "Diagnosis Procedure"](#).

Is the inspection result normal?

- YES >> GO TO 2.
NO >> Repair or replace error-detected parts.

2. CHECK TIRE

1. Turn the ignition switch OFF.
2. Check tire air pressure, wear and size. Refer to [WT-54, "Tire Air Pressure"](#).

Is the inspection result normal?

- YES >> GO TO 5.
NO >> Adjust air pressure or replace tire and GO TO 3.

3. CHECK DATA MONITOR (1)

Ⓜ With CONSULT

1. Erase self-diagnosis result for "ABS".
2. Turn the ignition switch OFF, and wait 10 seconds or more.
3. Start the engine.
4. Select "ABS" and "DATA MONITOR", check the "FR LH SENSOR", "FR RH SENSOR", "RR LH SENSOR" and "RR RH SENSOR".

NOTE:

C1115 WHEEL SENSOR

[WITH VDC]

< DTC/CIRCUIT DIAGNOSIS >

Set the "DATA MONITOR" recording speed to "10 msec".

5. Read a value (wheel speed) of both normal wheel sensors and error-detecting wheel sensor.

Regarding the deference at 30 km/h (19 MPH) between the wheel speed detected by the error detecting wheel sensor and the maximum/minimum wheel speed detected by the normal wheel sensors, is the difference within 5%, respectively?

- YES >> GO TO 4.
NO >> GO TO 5.

4.PERFORM SELF-DIAGNOSIS (1)

ⓅWith CONSULT

1. Drive the vehicle at approx. 30 km/h (19 MPH) or more for approx. 1 minute.
2. Stop the vehicle.
3. Perform self-diagnosis for "ABS".

Is DTC "C1115" detected?

- YES >> GO TO 5.
NO >> INSPECTION END

5.CHECK WHEEL SENSOR

1. Turn the ignition switch OFF.
2. Check the wheel sensor for damage.
3. Remove dust and foreign matter adhered to the sensor rotor with a vacuum dust collector through the wheel sensor mounting hole.

CAUTION:

Install wheel sensor with no backlash and float, and tighten the mounting bolt to the specified torque.

- Front: Refer to [BRC-132, "FRONT WHEEL SENSOR : Exploded View"](#).
- Rear: Refer to [BRC-133, "REAR WHEEL SENSOR : Exploded View"](#).

Is the inspection result normal?

- YES >> GO TO 8.
NO >> GO TO 6.

6.REPLACE WHEEL SENSOR (1)

ⓅWith CONSULT

1. Replace wheel sensor.
 - Front: Refer to [BRC-132, "FRONT WHEEL SENSOR : Removal and Installation"](#).
 - Rear: Refer to [BRC-135, "REAR WHEEL SENSOR : Removal and Installation"](#).
2. Erase self-diagnosis result for "ABS".
3. Turn the ignition switch OFF, and wait 10 seconds or more.
4. Start the engine.
5. Select "ABS" and "DATA MONITOR", check the "FR LH SENSOR", "FR RH SENSOR", "RR LH SENSOR" and "RR RH SENSOR".

NOTE:

Set the "DATA MONITOR" recording speed to "10 msec".

6. Read a value (wheel speed) of both normal wheel sensors and error-detecting wheel sensor.

Regarding the deference at 30 km/h (19 MPH) between the wheel speed detected by the error detecting wheel sensor and the maximum/minimum wheel speed detected by the normal wheel sensors, is the difference within 5%, respectively?

- YES >> GO TO 7.
NO >> GO TO 19.

7.PERFORM SELF-DIAGNOSIS (2)

ⓅWith CONSULT

1. Drive the vehicle at approx. 30 km/h (19 MPH) or more for approx. 1 minute.
2. Stop the vehicle.
3. Perform self-diagnosis for "ABS".

Is DTC "C1115" detected?

- YES >> GO TO 19.
NO >> INSPECTION END

C1115 WHEEL SENSOR

< DTC/CIRCUIT DIAGNOSIS >

[WITH VDC]

8. CHECK CONNECTOR

1. Turn the ignition switch OFF.
2. Check the ABS actuator and electric unit (control unit) harness connector for disconnection or looseness.
3. Check the wheel sensor harness connector for disconnection or looseness.

Is the inspection result normal?

YES >> GO TO 11.

NO >> Repair or replace error-detected parts, securely lock the harness connector, and GO TO 9.

9. CHECK DATA MONITOR (2)

Ⓜ With CONSULT

1. Erase self-diagnosis result for "ABS".
2. Turn the ignition switch OFF, and wait 10 seconds or more.
3. Start the engine.
4. Select "ABS" and "DATA MONITOR", check the "FR LH SENSOR", "FR RH SENSOR", "RR LH SENSOR" and "RR RH SENSOR".

NOTE:

Set the "DATA MONITOR" recording speed to "10 msec".

5. Read a value (wheel speed) of both normal wheel sensors and error-detecting wheel sensor.

Regarding the deference at 30 km/h (19 MPH) between the wheel speed detected by the error detecting wheel sensor and the maximum/minimum wheel speed detected by the normal wheel sensors, is the difference within 5%, respectively?

YES >> GO TO 10.

NO >> GO TO 11.

10. PERFORM SELF-DIAGNOSIS (3)

Ⓜ With CONSULT

1. Drive the vehicle at approx. 30 km/h (19 MPH) or more for approx. 1 minute.
2. Stop the vehicle.
3. Perform self-diagnosis for "ABS".

Is DTC "C1115" detected?

YES >> GO TO 11.

NO >> INSPECTION END

11. CHECK TERMINAL

1. Turn the ignition switch OFF.
2. Disconnect ABS actuator and electric unit (control unit) harness connector and then check the ABS actuator and electric unit (control unit) pin terminals for damage or loose connection with harness connector.
3. Disconnect wheel sensor harness connector and check the each wheel sensor pin terminals for damage or loose connection with harness connector.

Is the inspection result normal?

YES >> GO TO 14.

NO >> Repair or replace error-detected parts and GO TO 12.

12. CHECK DATA MONITOR (3)

Ⓜ With CONSULT

1. Connect ABS actuator and electric unit (control unit) harness connector.
2. Connect wheel sensor harness connector.
3. Erase self-diagnosis result for "ABS".
4. Turn the ignition switch OFF, and wait 10 seconds or more.
5. Start the engine.
6. Select "ABS" and "DATA MONITOR", check the "FR LH SENSOR", "FR RH SENSOR", "RR LH SENSOR" and "RR RH SENSOR".

NOTE:

Set the "DATA MONITOR" recording speed to "10 msec".

7. Read a value (wheel speed) of both normal wheel sensors and error-detecting wheel sensor.

Regarding the deference at 30 km/h (19 MPH) between the wheel speed detected by the error detecting wheel sensor and the maximum/minimum wheel speed detected by the normal wheel sensors, is the difference within 5%, respectively?

C1115 WHEEL SENSOR

[WITH VDC]

< DTC/CIRCUIT DIAGNOSIS >

- YES >> GO TO 13.
- NO >> GO TO 14.

13. PERFORM SELF-DIAGNOSIS (4)

Ⓜ With CONSULT

1. Drive the vehicle at approx. 30 km/h (19 MPH) or more for approx. 1 minute.
2. Stop the vehicle.
3. Perform self-diagnosis for "ABS".

Is DTC "C1115" detected?

- YES >> GO TO 14.
- NO >> INSPECTION END

14. CHECK WHEEL SENSOR HARNESS

1. Turn the ignition switch OFF.
2. Disconnect ABS actuator and electric unit (control unit) harness connector.
3. Disconnect wheel sensor harness connector.
4. Check the continuity between ABS actuator and electric unit (control unit) harness connector and wheel sensor harness connector. (Check the continuity when steering wheel is steered to RH and LH, or center harness in wheel housing is moved.)

Measurement connector and terminal for power supply circuit

ABS actuator and electric unit (control unit)		Wheel sensor		Continuity
Connector	Terminal	Connector	Terminal	
E35	23	E22 (Front LH wheel)	1	Existed
	21	E39 (Front RH wheel)		
	26	B44 (Rear LH wheel)		
	11	B41 ^{*1} (Rear RH wheel) B45 ^{*2} (Rear RH wheel)		

- *1: 2WD
- *2: AWD

Measurement connector and terminal for signal circuit

ABS actuator and electric unit (control unit)		Wheel sensor		Continuity
Connector	Terminal	Connector	Terminal	
E35	27	E22 (Front LH wheel)	2	Existed
	12	E39 (Front RH wheel)		
	30	B44 (Rear LH wheel)		
	15	B41 ^{*1} (Rear RH wheel) B45 ^{*2} (Rear RH wheel)		

- *1: 2WD
- *2: AWD

5. Check the continuity between ABS actuator and electric unit (control unit) harness connector and the ground.

ABS actuator and electric unit (control unit)		—	Continuity
Connector	Terminal		
E35	23, 27	Ground	Not existed
	21, 12		
	26, 30		
	11, 15		

Is the inspection result normal?

- YES >> GO TO 15.
- NO >> Repair or replace error-detected parts and GO TO 15.

C1115 WHEEL SENSOR

[WITH VDC]

< DTC/CIRCUIT DIAGNOSIS >

15. CHECK DATA MONITOR (4)

Ⓜ With CONSULT

1. Connect ABS actuator and electric unit (control unit) harness connector.
2. Connect wheel sensor harness connector.
3. Erase self-diagnosis result for "ABS".
4. Turn the ignition switch OFF, and wait 10 seconds or more.
5. Start the engine.
6. Select "ABS" and "DATA MONITOR", check the "FR LH SENSOR", "FR RH SENSOR", "RR LH SENSOR" and "RR RH SENSOR".

NOTE:

Set the "DATA MONITOR" recording speed to "10 msec".

7. Read a value (wheel speed) of both normal wheel sensors and error-detecting wheel sensor.

Regarding the deference at 30 km/h (19 MPH) between the wheel speed detected by the error detecting wheel sensor and the maximum/minimum wheel speed detected by the normal wheel sensors, is the difference within 5%. respectively?

YES >> GO TO 16.

NO >> GO TO 17.

16. PERFORM SELF-DIAGNOSIS (5)

Ⓜ With CONSULT

1. Drive the vehicle at approx. 30 km/h (19 MPH) or more for approx. 1 minute.
2. Stop the vehicle.
3. Perform self-diagnosis for "ABS".

Is DTC "C1115" detected?

YES >> GO TO 17.

NO >> INSPECTION END

17. REPLACE WHEEL SENSOR

Ⓜ With CONSULT

1. Replace wheel sensor.
 - Front: Refer to [BRC-132. "FRONT WHEEL SENSOR : Removal and Installation"](#).
 - Rear: Refer to [BRC-135. "REAR WHEEL SENSOR : Removal and Installation"](#).
2. Erase self-diagnosis result for "ABS".
3. Turn the ignition switch OFF, and wait 10 seconds or more.
4. Start the engine.
5. Select "ABS" and "DATA MONITOR", check the "FR LH SENSOR", "FR RH SENSOR", "RR LH SENSOR" and "RR RH SENSOR".

NOTE:

Set the "DATA MONITOR" recording speed to "10 msec".

6. Read a value (wheel speed) of both normal wheel sensors and error-detecting wheel sensor.

Regarding the deference at 30 km/h (19 MPH) between the wheel speed detected by the error detecting wheel sensor and the maximum/minimum wheel speed detected by the normal wheel sensors, is the difference within 5%. respectively?

YES >> GO TO 18.

NO >> GO TO 19.

18. PERFORM SELF-DIAGNOSIS (6)

Ⓜ With CONSULT

1. Drive the vehicle at approx. 30 km/h (19 MPH) or more for approx. 1 minute.
2. Stop the vehicle.
3. Perform self-diagnosis for "ABS".

Is DTC "C1115" detected?

YES >> GO TO 19.

NO >> INSPECTION END

19. REPLACE SENSOR ROTOR (2)

Ⓜ With CONSULT

1. Replace sensor rotor.

A
B
C
D
E
G
H
I
J
K
L
M
N
O
P

BRC

C1115 WHEEL SENSOR

[WITH VDC]

< DTC/CIRCUIT DIAGNOSIS >

- Front: Refer to [BRC-132. "FRONT WHEEL SENSOR : Removal and Installation"](#).
- Rear: Refer to [BRC-135. "REAR WHEEL SENSOR : Removal and Installation"](#).
- 2. Erase self-diagnosis result for "ABS".
- 3. Turn the ignition switch OFF, and wait 10 seconds or more.
- 4. Start the engine.
- 5. Drive the vehicle at approx. 30 km/h (19 MPH) or more for approx. 1 minute.
- 6. Stop the vehicle.
- 7. Perform self-diagnosis for "ABS".

Is DTC "C1115" detected?

- YES >> Replace ABS actuator and electric unit (control unit). Refer to [BRC-138. "Removal and Installation"](#).
- NO >> INSPECTION END

C1116 STOP LAMP SWITCH

< DTC/CIRCUIT DIAGNOSIS >

[WITH VDC]

C1116 STOP LAMP SWITCH

DTC Logic

INFOID:000000009752926

DTC DETECTION LOGIC

DTC	Display Item	Malfunction detected condition	Possible causes
C1116	STOP LAMP SW	When stop lamp switch signal is not input when brake pedal operates.	<ul style="list-style-type: none">• Harness or connector• Stop lamp switch• ABS actuator and electric unit (control unit)• Battery power supply system

DTC CONFIRMATION PROCEDURE

1. PRECONDITIONING

If "DTC CONFIRMATION PROCEDURE" has been previously conducted, always turn ignition switch OFF and wait at least 10 seconds before conducting the next test.

>> GO TO 2.

2. CHECK DTC DETECTION

Ⓜ With CONSULT

1. Turn the ignition switch OFF, and wait 10 seconds or more.
2. Start the engine.

CAUTION:

Never start the vehicle.

3. Depress the brake pedal several times.
4. Perform self-diagnosis for "ABS".

Is DTC "C1116" detected?

- YES >> Proceed to [BRC-87, "Diagnosis Procedure"](#).
NO >> INSPECTION END

Diagnosis Procedure

INFOID:000000009752927

NOTE:

DTC "C1116" may be detected when the brake pedal and the accelerator pedal are simultaneously depressed for 1 minute or more while driving the vehicle. This is not a malfunction.

1. INTERVIEW FROM THE CUSTOMER

Check if the brake pedal and the accelerator pedal are simultaneously depressed for 1 minute or more while driving the vehicle.

Is there such a history?

- YES >> GO TO 2.
NO >> GO TO 3.

2. PERFORM SELF-DIAGNOSIS

Ⓜ With CONSULT

1. Erase self-diagnosis result for "ABS".
2. Turn the ignition switch OFF, and wait 10 seconds or more.
3. Start the engine.

CAUTION:

Never start the vehicle.

4. Depress the brake pedal several times.
5. Perform self-diagnosis for "ABS".

Is DTC "C1116" detected?

- YES >> GO TO 3.
NO >> INSPECTION END

C1116 STOP LAMP SWITCH

[WITH VDC]

< DTC/CIRCUIT DIAGNOSIS >

3. STOP LAMP FOR ILLUMINATION

Depress brake pedal and check that stop lamp turns ON.

Does stop lamp turn ON?

YES >> GO TO 5.

NO >> Check the stop lamp system. Refer to [EXL-68, "Diagnosis Procedure"](#). GO TO 4.

4. CHECK DATA MONITOR (1)

Ⓜ With CONSULT

1. Erase self-diagnosis result for "ABS".
2. Turn the ignition switch OFF, and wait 10 seconds or more.
3. Start the engine.

CAUTION:

Never start the vehicle.

4. Select "ABS", "DATA MONITOR" and "STOP LAMP SW" according to this order. Check that data monitor displays "On" or "Off" when brake pedal is depress or release. Refer to [BRC-44, "Reference Value"](#).

Is the inspection result normal?

YES >> INSPECTION END

NO >> GO TO 5.

5. CHECK STOP LAMP SWITCH CLEARANCE

1. Turn the ignition switch OFF.
2. Check the stop lamp switch clearance. Refer to [BR-7, "Inspection and Adjustment"](#).

Is the inspection result normal?

YES >> GO TO 7.

NO >> Adjust stop lamp switch clearance. Refer to [BR-7, "Inspection and Adjustment"](#). GO TO 6.

6. CHECK DATA MONITOR (2)

Ⓜ With CONSULT

1. Erase self-diagnosis result for "ABS".
2. Turn the ignition switch OFF, and wait 10 seconds or more.
3. Start the engine.

CAUTION:

Never start the vehicle.

4. Select "ABS", "DATA MONITOR" and "STOP LAMP SW" according to this order. Check that data monitor displays "On" or "Off" when brake pedal is depress or release. Refer to [BRC-44, "Reference Value"](#).

Is the inspection result normal?

YES >> INSPECTION END

NO >> GO TO 7.

7. CHECK STOP LAMP SWITCH

Check the stop lamp switch. Refer to [BRC-90, "Component Inspection"](#).

Is the inspection result normal?

YES >> GO TO 9.

NO >> Replace stop lamp switch. Refer to [BR-18, "Removal and Installation"](#). GO TO 8.

8. CHECK DATA MONITOR (3)

Ⓜ With CONSULT

1. Erase self-diagnosis result for "ABS".
2. Turn the ignition switch OFF, and wait 10 seconds or more.
3. Start the engine.

CAUTION:

Never start the vehicle.

4. Select "ABS", "DATA MONITOR" and "STOP LAMP SW" according to this order. Check that data monitor displays "On" or "Off" when brake pedal is depress or release. Refer to [BRC-44, "Reference Value"](#).

Is the inspection result normal?

YES >> INSPECTION END

NO >> GO TO 9.

C1116 STOP LAMP SWITCH

< DTC/CIRCUIT DIAGNOSIS >

[WITH VDC]

9. CHECK CONNECTOR AND TERMINAL

1. Turn the ignition switch OFF.
2. Disconnect ABS actuator and electric unit (control unit) harness connector.
3. Check the ABS actuator and electric unit (control unit) harness connector for disconnection or looseness.
4. Check the ABS actuator and electric unit (control unit) pin terminals for damage or loose connection with harness connector.
5. Disconnect stop lamp switch harness connector.
6. Check the stop lamp switch harness connector for disconnection or looseness.
7. Check the stop lamp switch pin terminals for damage or loose connection with harness connector.

Is the inspection result normal?

YES >> GO TO 11.

NO >> Repair or replace error-detected parts. GO TO 10.

10. CHECK DATA MONITOR (4)

Ⓜ With CONSULT

1. Connect ABS actuator and electric unit (control unit) harness connector.
2. Connect stop lamp switch harness connector.
3. Erase self-diagnosis result for "ABS".
4. Turn the ignition switch OFF, and wait 10 seconds or more.
5. Start the engine.

CAUTION:

Never start the vehicle.

6. Select "ABS", "DATA MONITOR" and "STOP LAMP SW" according to this order. Check that data monitor displays "On" or "Off" when brake pedal is depress or release. Refer to [BRC-44, "Reference Value"](#).

Is the inspection result normal?

YES >> INSPECTION END

NO >> GO TO 11.

11. CHECK STOP LAMP SWITCH CIRCUIT (1)

1. Turn the ignition switch OFF.
2. Disconnect ABS actuator and electric unit (control unit) harness connector.
3. Check the voltage between ABS actuator and electric unit (control unit) harness connector and ground.

ABS actuator and electric unit (control unit)		—	Condition	Voltage
Connector	Terminal			
E35	8	Ground	Brake pedal depressed	Battery voltage
			Brake pedal not depressed	Approx. 0 V

4. Turn the ignition switch ON.
5. Check the voltage between ABS actuator and electric unit (control unit) harness connector and ground.

ABS actuator and electric unit (control unit)		—	Condition	Voltage
Connector	Terminal			
E35	8	Ground	Brake pedal depressed	Battery voltage
			Brake pedal not depressed	Approx. 0 V

Is the inspection result normal?

YES >> Replace ABS actuator and electric unit (control unit). Refer to [BRC-138, "Removal and Installation"](#).

NO >> Repair or replace error-detected parts. GO TO 12.

12. CHECK STOP LAMP SWITCH CIRCUIT (2)

1. Turn the ignition switch OFF.
2. Disconnect stop lamp switch harness connector.
3. Check the continuity between ABS actuator and electric unit (control unit) harness connector and stop lamp switch harness connector.

C1116 STOP LAMP SWITCH

< DTC/CIRCUIT DIAGNOSIS >

[WITH VDC]

ABS actuator and electric unit (control unit)		Stop lamp switch		Continuity
Connector	Terminal	Connector	Terminal	
E35	8	E102*1 E118*2	2	Existed

*1: Models with CVT

*2: Models with M/T

4. Check the continuity between ABS actuator and electric unit (control unit) harness connector and the ground.

ABS actuator and electric unit (control unit)		—	Continuity
Connector	Terminal		
E35	8	Ground	Not existed

Is the inspection result normal?

YES >> Replace ABS actuator and electric unit (control unit). Refer to [BRC-138, "Removal and Installation"](#).

NO >> Repair or replace error-detected parts. GO TO 13.

13.CHECK DATA MONITOR (5)

 With CONSULT

1. Connect ABS actuator and electric unit (control unit) harness connector.
2. Connect stop lamp switch harness connector.
3. Erase self-diagnosis result for "ABS".
4. Turn the ignition switch OFF, and wait 10 seconds or more.
5. Start the engine.

CAUTION:

Never start the vehicle.

6. Select "ABS", "DATA MONITOR" and "STOP LAMP SW" according to this order. Check that data monitor displays "On" or "Off" when brake pedal is depress or release. Refer to [BRC-44, "Reference Value"](#).

Is the inspection result normal?

YES >> INSPECTION END

NO >> Replace ABS actuator and electric unit (control unit). Refer to [BRC-138, "Removal and Installation"](#).

Component Inspection

INFOID:000000009752928

1.CHECK STOP LAMP SWITCH

1. Turn the ignition switch OFF.
2. Disconnect stop lamp switch harness connector.
3. Check the continuity between stop lamp switch connector terminals.

Stop lamp switch	Condition	Continuity
Terminal		
1 - 2	When stop lamp switch is released (When brake pedal is depressed)	Existed
	When stop lamp switch is pressed (When brake pedal is released)	Not existed

Is the inspection result normal?

YES >> INSPECTION END

NO >> Replace stop lamp switch. Refer to [BR-18, "Removal and Installation"](#).

C1120, C1122, C1124, C1126 ABS IN VALVE SYSTEM

< DTC/CIRCUIT DIAGNOSIS >

[WITH VDC]

C1120, C1122, C1124, C1126 ABS IN VALVE SYSTEM

DTC Logic

INFOID:000000009752929

DTC DETECTION LOGIC

DTC	Display Item	Malfunction detected condition	Possible causes
C1120	FR LH IN ABS SOL	When a malfunction is detected in front LH ABS IN valve.	<ul style="list-style-type: none"> • Harness or connector • ABS actuator and electric unit (control unit) • Fusible link • Battery power supply system
C1122	FR RH IN ABS SOL	When a malfunction is detected in front RH ABS IN valve.	
C1124	RR LH IN ABS SOL	When a malfunction is detected in rear LH ABS IN valve.	
C1126	RR RH IN ABS SOL	When a malfunction is detected in rear RH ABS IN valve.	

DTC CONFIRMATION PROCEDURE

1. PRECONDITIONING

If "DTC CONFIRMATION PROCEDURE" has been previously conducted, always turn ignition switch OFF and wait at least 10 seconds before conducting the next test.

>> GO TO 2.

2. CHECK DTC DETECTION

Ⓜ With CONSULT

1. Turn the ignition switch OFF to ON.
2. Perform self-diagnosis for "ABS".

Is DTC "C1120", "C1122", "C1124" or "C1126" detected?

- YES >> Proceed to [BRC-91, "Diagnosis Procedure"](#).
 NO >> INSPECTION END

Diagnosis Procedure

INFOID:000000009752930

1. CHECK CONNECTOR

1. Turn the ignition switch OFF.
2. Check the ABS actuator and electric unit (control unit) harness connector for disconnection or looseness.

Is the inspection result normal?

- YES >> GO TO 3.
 NO >> Repair or replace error-detected parts, securely lock the harness connector, and GO TO 2.

2. PERFORM SELF-DIAGNOSIS

Perform self-diagnosis for "ABS" again.

Is DTC "C1120", "C1122", "C1124" or "C1126" detected?

- YES >> GO TO 3.
 NO >> INSPECTION END

3. CHECK ABS IN VALVE POWER SUPPLY

1. Turn the ignition switch OFF.
2. Disconnect ABS actuator and electric unit (control unit) harness connector.
3. Check the voltage between ABS actuator and electric unit (control unit) harness connector and ground.

ABS actuator and electric unit (control unit)		—	Voltage
Connector	Terminal		
E35	2	Ground	10 – 16 V

C1120, C1122, C1124, C1126 ABS IN VALVE SYSTEM

[WITH VDC]

< DTC/CIRCUIT DIAGNOSIS >

4. Turn the ignition switch ON.

CAUTION:

Never start engine.

5. Check the voltage between ABS actuator and electric unit (control unit) harness connector and ground.

ABS actuator and electric unit (control unit)		—	Voltage
Connector	Terminal		
E35	2	Ground	10 – 16 V

Is the inspection result normal?

YES >> GO TO 5.

NO >> GO TO 4.

4.CHECK ABS IN VALVE POWER SUPPLY CIRCUIT

1. Turn the ignition switch OFF.

2. Check the 50A fusible link (I).

3. Check the continuity and short circuit between ABS actuator and electric unit (control unit) harness connector terminal (2) and 50A fusible link (I).

Is the inspection result normal?

YES >> Perform trouble diagnosis for battery power supply. Refer to [PG-11, "Wiring Diagram - BATTERY POWER SUPPLY -"](#).

NO >> Repair or replace error-detected parts.

5.CHECK ABS IN VALVE GROUND CIRCUIT

1. Turn the ignition switch OFF.

2. Check the continuity between ABS actuator and electric unit (control unit) harness connector and the ground.

ABS actuator and electric unit (control unit)		—	Continuity
Connector	Terminal		
E35	3	Ground	Existed
	4		

Is the inspection result normal?

YES >> GO TO 6.

NO >> Repair or replace error-detected parts.

6.CHECK TERMINAL

Check the ABS actuator and electric unit (control unit) pin terminals for damage or loose connection with harness connector.

Is the inspection result normal?

YES >> Replace ABS actuator and electric unit (control unit). Refer to [BRC-138, "Removal and Installation"](#).

NO >> Repair or replace error-detected parts.

C1121, C1123, C1125, C1127 ABS OUT VALVE SYSTEM

< DTC/CIRCUIT DIAGNOSIS >

[WITH VDC]

C1121, C1123, C1125, C1127 ABS OUT VALVE SYSTEM

DTC Logic

INFOID:000000009752931

DTC DETECTION LOGIC

DTC	Display Item	Malfunction detected condition	Possible causes
C1121	FR LH OUT ABS SOL	When a malfunction is detected in front LH ABS OUT valve.	<ul style="list-style-type: none"> • Harness or connector • ABS actuator and electric unit (control unit) • Fusible link • Battery power supply system
C1123	FR RH OUT ABS SOL	When a malfunction is detected in front RH ABS OUT valve.	
C1125	RR LH OUT ABS SOL	When a malfunction is detected in rear LH ABS OUT valve.	
C1127	RR RH OUT ABS SOL	When a malfunction is detected in rear RH ABS OUT valve.	

DTC CONFIRMATION PROCEDURE

1. PRECONDITIONING

If "DTC CONFIRMATION PROCEDURE" has been previously conducted, always turn ignition switch OFF and wait at least 10 seconds before conducting the next test.

>> GO TO 2.

2. CHECK DTC DETECTION

Ⓜ With CONSULT

1. Turn the ignition switch OFF to ON.
2. Perform self-diagnosis for "ABS".

Is DTC "C1121", "C1123", "C1125" or "C1127" detected?

- YES >> Proceed to [BRC-93. "Diagnosis Procedure"](#).
 NO >> INSPECTION END

Diagnosis Procedure

INFOID:000000009752932

1. CHECK CONNECTOR

1. Turn the ignition switch OFF.
2. Check the ABS actuator and electric unit (control unit) harness connector for disconnection or looseness.

Is the inspection result normal?

- YES >> GO TO 3.
 NO >> Repair or replace error-detected parts, securely lock the harness connector, and GO TO 2.

2. PERFORM SELF-DIAGNOSIS

Perform self-diagnosis for "ABS" again.

Is DTC "C1121", "C1123", "C1125" or "C1127" detected?

- YES >> GO TO 3.
 NO >> INSPECTION END

3. CHECK ABS OUT VALVE POWER SUPPLY

1. Turn the ignition switch OFF.
2. Disconnect ABS actuator and electric unit (control unit) harness connector.
3. Check the voltage between ABS actuator and electric unit (control unit) harness connector and ground.

ABS actuator and electric unit (control unit)		—	Voltage
Connector	Terminal		
E35	2	Ground	10 – 16 V

C1121, C1123, C1125, C1127 ABS OUT VALVE SYSTEM

[WITH VDC]

< DTC/CIRCUIT DIAGNOSIS >

4. Turn the ignition switch ON.

CAUTION:

Never start engine.

5. Check the voltage between ABS actuator and electric unit (control unit) harness connector and ground.

ABS actuator and electric unit (control unit)		—	Voltage
Connector	Terminal		
E35	2	Ground	10 – 16 V

Is the inspection result normal?

YES >> GO TO 5.

NO >> GO TO 4.

4.CHECK ABS OUT VALVE POWER SUPPLY CIRCUIT

1. Turn the ignition switch OFF.

2. Check the 50A fusible link (I).

3. Check the continuity and short circuit between ABS actuator and electric unit (control unit) harness connector terminal (2) and 50A fusible link (I).

Is the inspection result normal?

YES >> Perform trouble diagnosis for battery power supply. Refer to [PG-11, "Wiring Diagram - BATTERY POWER SUPPLY -"](#).

NO >> Repair or replace error-detected parts.

5.CHECK ABS OUT VALVE GROUND CIRCUIT

1. Turn the ignition switch OFF.

2. Check the continuity between ABS actuator and electric unit (control unit) harness connector and the ground.

ABS actuator and electric unit (control unit)		—	Continuity
Connector	Terminal		
E35	3	Ground	Existed
	4		

Is the inspection result normal?

YES >> GO TO 6.

NO >> Repair or replace error-detected parts.

6.CHECK TERMINAL

Check the ABS actuator and electric unit (control unit) pin terminals for damage or loose connection with harness connector.

Is the inspection result normal?

YES >> Replace ABS actuator and electric unit (control unit). Refer to [BRC-138, "Removal and Installation"](#).

NO >> Repair or replace error-detected parts.

C1130 ENGINE SIGNAL

< DTC/CIRCUIT DIAGNOSIS >

[WITH VDC]

C1130 ENGINE SIGNAL

DTC Logic

INFOID:000000009752933

DTC DETECTION LOGIC

DTC	Display Item	Malfunction detected condition	Possible causes
C1130	ENGINE SIGNAL 1	When a malfunction is detected in ECM system.	<ul style="list-style-type: none">• ECM• ABS actuator and electric unit (control unit)• CAN communication line

DTC CONFIRMATION PROCEDURE

1. PRECONDITIONING

If "DTC CONFIRMATION PROCEDURE" has been previously conducted, always turn ignition switch OFF and wait at least 10 seconds before conducting the next test.

>> GO TO 2.

2. CHECK DTC DETECTION

Ⓜ With CONSULT

1. Turn the ignition switch OFF to ON.
2. Perform self-diagnosis for "ABS".

Is DTC "C1130" detected?

- YES >> Proceed to [BRC-95, "Diagnosis Procedure"](#).
NO >> INSPECTION END

Diagnosis Procedure

INFOID:000000009752934

1. CHECK ENGINE SYSTEM

Ⓜ With CONSULT

Perform self-diagnosis for "ENGINE".

Is any DTC detected?

- YES >> Check the DTC.
NO >> GO TO 2.

2. CHECK ABS ACTUATOR AND ELECTRIC UNIT (CONTROL UNIT)

Ⓜ With CONSULT

1. Erase Self-diagnosis result for "ABS".
2. Turn the ignition switch OFF and wait 10 second or more.
3. Start the engine and drive the vehicle for a short period of time.
4. Stop the vehicle.
5. Check that the malfunction indicator lamp (MIL) turns OFF.
6. After the vehicle stops, perform self-diagnosis for "ABS".

Is DTC "C1130" detected?

- YES >> Replace ABS actuator and electric unit (control unit). Refer to [BRC-138, "Removal and Installation"](#).
NO >> Check the pin terminals and connection of each harness connector for abnormal conditions. Repair or replace error-detected parts.

C1140 ACTUATOR RELAY SYSTEM

< DTC/CIRCUIT DIAGNOSIS >

[WITH VDC]

C1140 ACTUATOR RELAY SYSTEM

DTC Logic

INFOID:000000009752935

DTC DETECTION LOGIC

DTC	Display Item	Malfunction detected condition	Possible causes
C1140	ACTUATOR RLY	When a malfunction is detected in actuator relay.	<ul style="list-style-type: none"> • Harness or connector • ABS actuator and electric unit (control unit) • Fusible link • Battery power supply system

DTC CONFIRMATION PROCEDURE

1. PRECONDITIONING

If "DTC CONFIRMATION PROCEDURE" has been previously conducted, always turn ignition switch OFF and wait at least 10 seconds before conducting the next test.

>> GO TO 2.

2. CHECK DTC DETECTION

Ⓟ With CONSULT

1. Turn the ignition switch OFF to ON.
2. Perform self-diagnosis for "ABS".

Is DTC "C1140" detected?

YES >> Proceed to [BRC-96. "Diagnosis Procedure"](#).

NO >> INSPECTION END

Diagnosis Procedure

INFOID:000000009752936

1. CHECK CONNECTOR

1. Turn the ignition switch OFF.
2. Check the ABS actuator and electric unit (control unit) harness connector for disconnection or looseness.

Is the inspection result normal?

YES >> GO TO 3.

NO >> Repair or replace error-detected parts, securely lock the harness connector, and GO TO 2.

2. PERFORM SELF-DIAGNOSIS

Perform self-diagnosis for "ABS" again.

Is DTC "C1140" detected?

YES >> GO TO 3.

NO >> INSPECTION END

3. CHECK ACTUATOR RELAY POWER SUPPLY

1. Turn the ignition switch OFF.
2. Disconnect ABS actuator and electric unit (control unit) harness connector.
3. Check the voltage between ABS actuator and electric unit (control unit) harness connector and ground.

ABS actuator and electric unit (control unit)		—	Voltage
Connector	Terminal		
E35	2	Ground	10 – 16 V

4. Turn the ignition switch ON.

CAUTION:

Never start engine.

5. Check the voltage between ABS actuator and electric unit (control unit) harness connector and ground.

C1140 ACTUATOR RELAY SYSTEM

[WITH VDC]

< DTC/CIRCUIT DIAGNOSIS >

ABS actuator and electric unit (control unit)		—	Voltage
Connector	Terminal		
E35	2	Ground	10 – 16 V

Is the inspection result normal?

YES >> GO TO 5.

NO >> GO TO 4.

4.CHECK ACTUATOR RELAY POWER SUPPLY CIRCUIT

1. Turn the ignition switch OFF.
2. Check the 50A fusible link (I).
3. Check the continuity and short circuit between ABS actuator and electric unit (control unit) harness connector terminal (2) and 50A fusible link (I).

Is the inspection result normal?

YES >> Perform trouble diagnosis for battery power supply. Refer to [PG-11, "Wiring Diagram - BATTERY POWER SUPPLY -"](#).

NO >> Repair or replace error-detected parts.

5.CHECK ACTUATOR RELAY GROUND CIRCUIT

1. Turn the ignition switch OFF.
2. Check the continuity between ABS actuator and electric unit (control unit) harness connector and the ground.

ABS actuator and electric unit (control unit)		—	Continuity
Connector	Terminal		
E35	3	Ground	Existed
	4		

Is the inspection result normal?

YES >> GO TO 6.

NO >> Repair or replace error-detected parts.

6.CHECK TERMINAL

Check the ABS actuator and electric unit (control unit) pin terminals for damage or loose connection with harness connector.

Is the inspection result normal?

YES >> Replace ABS actuator and electric unit (control unit). Refer to [BRC-138, "Removal and Installation"](#).

NO >> Repair or replace error-detected parts.

C1143 STEERING ANGLE SENSOR

< DTC/CIRCUIT DIAGNOSIS >

[WITH VDC]

C1143 STEERING ANGLE SENSOR

DTC Logic

INFOID:000000009752937

DTC DETECTION LOGIC

DTC	Display Item	Malfunction detected condition	Possible causes
C1143	ST ANG SEN CIRCUIT	When a malfunction is detected in steering angle sensor.	<ul style="list-style-type: none">• Harness or connector• Steering angle sensor• ABS actuator and electric unit (control unit)• Fuse• Ignition power supply system• CAN communication line

DTC CONFIRMATION PROCEDURE

1. PRECONDITIONING

If "DTC CONFIRMATION PROCEDURE" has been previously conducted, always turn ignition switch OFF and wait at least 10 seconds before conducting the next test.

>> GO TO 2.

2. CHECK DTC DETECTION

Ⓟ With CONSULT

1. Turn the ignition switch OFF to ON.
2. Perform self-diagnosis for "ABS".

Is DTC "C1143" detected?

- YES >> Proceed to [BRC-98, "Diagnosis Procedure"](#).
NO >> INSPECTION END

Diagnosis Procedure

INFOID:000000009752938

1. CHECK CONNECTOR

1. Turn the ignition switch OFF.
2. Check the ABS actuator and electric unit (control unit) harness connector for disconnection or looseness.
3. Check the steering angle sensor harness connector for disconnection or looseness.

Is the inspection result normal?

- YES >> GO TO 3.
NO >> Repair or replace error-detected parts, securely lock the harness connector, and GO TO 2.

2. PERFORM SELF-DIAGNOSIS

Perform self-diagnosis for "ABS" again.

Is DTC "C1143" detected?

- YES >> GO TO 3.
NO >> INSPECTION END

3. CHECK STEERING ANGLE SENSOR POWER SUPPLY

1. Turn the ignition switch OFF.
2. Disconnect steering angle sensor harness connector.
3. Check the voltage between steering angle sensor harness connector and ground.

Steering angle sensor		—	Voltage
Connector	Terminal		
M30	4	Ground	Approx. 0 V

4. Turn the ignition switch ON.

C1143 STEERING ANGLE SENSOR

[WITH VDC]

< DTC/CIRCUIT DIAGNOSIS >

CAUTION:

Never start engine.

5. Check the voltage between steering angle sensor harness connector and ground.

Steering angle sensor		—	Voltage
Connector	Terminal		
M30	4	Ground	Battery voltage

Is the inspection result normal?

YES >> GO TO 5.

NO >> GO TO 4.

4.CHECK STEERING ANGLE SENSOR POWER SUPPLY CIRCUIT

1. Turn the ignition switch OFF.
2. Check the 10A fuse (#3).
3. Check the continuity and short circuit between steering angle sensor harness connector terminal (4) and 10A fuse (#3).

Is the inspection result normal?

YES >> Perform trouble diagnosis for ignition power supply. Refer to [PG-41, "Wiring Diagram - IGNITION POWER SUPPLY -"](#).

NO >> Repair or replace error-detected parts.

5.CHECK STEERING ANGLE SENSOR GROUND CIRCUIT

1. Turn the ignition switch OFF.
2. Check the continuity between steering angle sensor harness connector and ground.

Steering angle sensor		—	Continuity
Connector	Terminal		
M30	1	Ground	Existed

Is the inspection result normal?

YES >> GO TO 6.

NO >> Repair or replace error-detected parts.

6.CHECK TERMINAL

Check the steering angle sensor pin terminals for damage or loose connection with harness connector.

Is the inspection result normal?

YES >> GO TO 7.

NO >> Repair or replace error-detected parts.

7.CHECK CAN COMMUNICATION LINE

Check the "STRG BRANCH LINE CIRCUIT". Refer to [LAN-51, "Diagnosis Procedure"](#).

Is the inspection result normal?

YES >> Replace ABS actuator and electric unit (control unit). Refer to [BRC-138, "Removal and Installation"](#).

NO >> Repair or replace error-detected parts. Refer to [BRC-7, "Precaution for Harness Repair"](#).

A
B
C
D
E
BRC
G
H
I
J
K
L
M
N
O
P

C1144 INCOMPLETE STEERING ANGLE SENSOR ADJUSTMENT

< DTC/CIRCUIT DIAGNOSIS >

[WITH VDC]

C1144 INCOMPLETE STEERING ANGLE SENSOR ADJUSTMENT

DTC Logic

INFOID:000000009752939

DTC DETECTION LOGIC

DTC	Display Item	Malfunction detected condition	Possible causes
C1144	ST ANG SEN SIGNAL	When neutral position adjustment of steering angle sensor is not complete.	<ul style="list-style-type: none">• Harness or connector• Steering angle sensor• ABS actuator and electric unit (control unit)• Incomplete neutral position adjustment of steering angle sensor

DTC CONFIRMATION PROCEDURE

1. PRECONDITIONING

If "DTC CONFIRMATION PROCEDURE" has been previously conducted, always turn ignition switch OFF and wait at least 10 seconds before conducting the next test.

>> GO TO 2.

2. CHECK DTC DETECTION

Ⓜ With CONSULT

1. Turn the ignition switch OFF to ON.
2. Perform self-diagnosis for "ABS".

Is DTC "C1144" detected?

- YES >> Proceed to [BRC-100, "Diagnosis Procedure"](#).
NO >> INSPECTION END

Diagnosis Procedure

INFOID:000000009752940

1. ADJUST THE NEUTRAL POSITION OF STEERING ANGLE SENSOR

Perform neutral position adjustment of steering angle sensor. Refer to [BRC-62, "Work Procedure"](#).

>> GO TO 2.

2. CHECK ABS ACTUATOR AND ELECTRIC UNIT (CONTROL UNIT)

Ⓜ With CONSULT

Perform self-diagnosis for "ABS".

Is DTC "C1144" detected?

- YES >> GO TO 3.
NO >> INSPECTION END

3. CHECK STEERING ANGLE SENSOR SYSTEM

1. Turn the ignition switch OFF.
2. Check the steering angle sensor system. Refer to [BRC-98, "Diagnosis Procedure"](#).

Is the inspection result normal?

- YES >> Replace ABS actuator and electric unit (control unit). Refer to [BRC-138, "Removal and Installation"](#).
NO >> Repair or replace error-detected parts.

C1155 BRAKE FLUID LEVEL SWITCH

[WITH VDC]

< DTC/CIRCUIT DIAGNOSIS >

C1155 BRAKE FLUID LEVEL SWITCH

DTC Logic

INFOID:000000009752941

DTC DETECTION LOGIC

DTC	Display Item	Malfunction detected condition	Possible causes
C1155	BR FLUID LEVEL LOW	<ul style="list-style-type: none">When brake fluid level low signal is detected.When an open circuit is detected in brake fluid level switch circuit.	<ul style="list-style-type: none">Harness or connectorABS actuator and electric unit (control unit)Brake fluid level switchCombination meter

DTC CONFIRMATION PROCEDURE

1. PRECONDITIONING

If "DTC CONFIRMATION PROCEDURE" has been previously conducted, always turn ignition switch OFF and wait at least 10 seconds before conducting the next test.

>> GO TO 2.

2. CHECK DTC DETECTION

Ⓜ With CONSULT

- Turn the ignition switch OFF to ON.
- Perform self-diagnosis for "ABS".

Is DTC "C1155" detected?

- YES >> Proceed to [BRC-101, "Diagnosis Procedure"](#).
NO >> INSPECTION END

Diagnosis Procedure

INFOID:000000009752942

1. CHECK BRAKE FLUID LEVEL

- Turn the ignition switch OFF.
- Check the brake fluid level. Refer to [BR-10, "Inspection"](#).

Is the inspection result normal?

- YES >> GO TO 2.
NO >> Refill brake fluid. Refer to [BR-10, "Refilling"](#).

2. PERFORM SELF-DIAGNOSIS (1)

Ⓜ With CONSULT

- Erase self-diagnosis result for "ABS".
- Turn the ignition switch OFF, and wait 10 seconds or more.
- Turn the ignition switch ON.

CAUTION:

Never start the engine.

- Perform self-diagnosis for "ABS".

Is DTC "C1155" detected?

- YES >> INSPECTION END
NO >> GO TO 3.

3. CHECK BRAKE FLUID LEVEL SWITCH

Check the brake fluids level switch. Refer to [BRC-103, "Component Inspection"](#).

Is the inspection result normal?

- YES >> GO TO 5.
NO >> Replace reservoir tank. Refer to [BR-35, "Disassembly and Assembly"](#). GO TO 4.

4. PERFORM SELF-DIAGNOSIS (2)

C1155 BRAKE FLUID LEVEL SWITCH

[WITH VDC]

< DTC/CIRCUIT DIAGNOSIS >

Ⓟ With CONSULT

1. Erase self-diagnosis result for "ABS".
2. Turn the ignition switch OFF, and wait 10 seconds or more.
3. Turn the ignition switch ON.

CAUTION:

Never start the engine.

4. Perform self-diagnosis for "ABS".

Is DTC "C1155" detected?

YES >> INSPECTION END

NO >> GO TO 5.

5. CHECK CONNECTOR AND TERMINAL

1. Turn the ignition switch OFF.
2. Disconnect brake fluid level switch harness connector.
3. Check the brake fluid level switch harness connector for disconnection or looseness.
4. Check the brake fluid level switch pin terminals for damage or loose connection with harness connector.
5. Disconnect combination meter harness connector.
6. Check the combination meter harness connector for disconnection or looseness.
7. Check the combination meter pin terminals for damage or loose connection with harness connector.

Is the inspection result normal?

YES >> GO TO 7.

NO >> Repair or replace error-detected parts. GO TO 6.

6. PERFORM SELF-DIAGNOSIS (3)

Ⓟ With CONSULT

1. Connect brake fluid level switch harness connector.
2. Connect combination meter harness connector.
3. Erase self-diagnosis result for "ABS".
4. Turn the ignition switch OFF, and wait 10 seconds or more.
5. Turn the ignition switch ON.

CAUTION:

Never start the engine.

6. Perform self-diagnosis for "ABS".

Is DTC "C1155" detected?

YES >> INSPECTION END

NO >> GO TO 7.

7. CHECK BRAKE FLUID LEVEL SWITCH HARNESS

1. Turn the ignition switch OFF.
2. Disconnect brake fluid level switch harness connector.
3. Disconnect combination meter harness connector.
4. Check the continuity between brake fluid level switch harness connector and combination meter harness connector.

Brake fluid level switch		Combination meter		Continuity
Connector	Terminal	Connector	Terminal	
E37	1	M34	11	Existed

5. Check the continuity between brake fluid level switch harness connector and ground.

Brake fluid level switch		—	Continuity
Connector	Terminal		
E37	1	Ground	Not existed

Is the inspection result normal?

YES >> GO TO 8.

NO >> Repair or replace error-detected parts. GO TO 8.

C1155 BRAKE FLUID LEVEL SWITCH

[WITH VDC]

< DTC/CIRCUIT DIAGNOSIS >

8. CHECK BRAKE FLUID LEVEL SWITCH GROUND

Check the continuity between brake fluid level switch harness connector and ground.

Brake fluid level switch		—	Continuity
Connector	Terminal		
E37	2	Ground	Existed

Is the inspection result normal?

YES >> GO TO 9.

NO >> Repair or replace error-detected parts. GO TO 9.

9. CHECK COMBINATION METER

Check the combination meter. Refer to [MWI-21, "CONSULT Function"](#).

Is the inspection result normal?

YES >> Replace ABS actuator and electric unit (control unit). Refer to [BRC-138, "Removal and Installation"](#).

NO >> Repair or replace combination meter. Refer to [MWI-61, "Removal and Installation"](#).

Component Inspection

INFOID:000000009752943

1. CHECK BRAKE FLUID LEVEL SWITCH

1. Turn the ignition switch OFF.
2. Disconnect brake fluid level switch harness connector.
3. Check the continuity between brake fluid level switch connector terminals.

Brake fluid level switch	Condition	Continuity
Terminal		
1 – 2	When brake fluid level in reservoir tank is within the specified level.	Not existed
	When brake fluid level in reservoir tank is less than the specified level.	Existed

Is the inspection result normal?

YES >> INSPECTION END

NO >> Replace reservoir tank. Refer to [BR-35, "Disassembly and Assembly"](#).

C1164, C1165 CV SYSTEM

DTC Logic

INFOID:000000009752944

DTC DETECTION LOGIC

DTC	Display Item	Malfunction detected condition	Possible causes
C1164	CV 1	When a malfunction is detected in cut valve 1.	<ul style="list-style-type: none"> Harness or connector ABS actuator and electric unit (control unit) Fusible link Battery power supply system
C1165	CV 2	When a malfunction is detected in cut valve 2.	

DTC CONFIRMATION PROCEDURE

1. PRECONDITIONING

If "DTC CONFIRMATION PROCEDURE" has been previously conducted, always turn ignition switch OFF and wait at least 10 seconds before conducting the next test.

>> GO TO 2.

2. CHECK DTC DETECTION

With CONSULT

1. Turn the ignition switch OFF to ON.
2. Perform self-diagnosis for "ABS".

Is DTC "C1164" or "C1165" detected?

- YES >> Proceed to [BRC-104, "Diagnosis Procedure"](#).
 NO >> INSPECTION END

Diagnosis Procedure

INFOID:000000009752945

1. CHECK CONNECTOR

1. Turn the ignition switch OFF.
2. Check the ABS actuator and electric unit (control unit) harness connector for disconnection or looseness.

Is the inspection result normal?

- YES >> GO TO 3.
 NO >> Repair or replace error-detected parts, securely lock the harness connector, and GO TO 2.

2. PERFORM SELF-DIAGNOSIS

Perform self-diagnosis for "ABS" again.

Is DTC "C1164" or "C1165" detected?

- YES >> GO TO 3.
 NO >> INSPECTION END

3. CHECK CUT VALVE POWER SUPPLY

1. Turn the ignition switch OFF.
2. Disconnect ABS actuator and electric unit (control unit) harness connector.
3. Check the voltage between ABS actuator and electric unit (control unit) harness connector and ground.

ABS actuator and electric unit (control unit)		—	Voltage
Connector	Terminal		
E35	2	Ground	Battery voltage

4. Turn the ignition switch ON.

CAUTION:

Never start engine.

5. Check the voltage between ABS actuator and electric unit (control unit) harness connector and ground.

< DTC/CIRCUIT DIAGNOSIS >

ABS actuator and electric unit (control unit)		—	Voltage
Connector	Terminal		
E35	2	Ground	Battery voltage

Is the inspection result normal?

- YES >> GO TO 5.
- NO >> GO TO 4.

4. CHECK CUT VALVE POWER SUPPLY CIRCUIT

1. Turn the ignition switch OFF.
2. Check the 50A fusible link (I).
3. Check the continuity and short circuit between ABS actuator and electric unit (control unit) harness connector terminal (2) and 50A fusible link (I).

Is the inspection result normal?

- YES >> Perform trouble diagnosis for battery power supply. Refer to [PG-11, "Wiring Diagram - BATTERY POWER SUPPLY -"](#).
- NO >> Repair or replace error-detected parts.

5. CHECK CUT VALVE GROUND CIRCUIT

1. Turn the ignition switch OFF.
2. Check the continuity between ABS actuator and electric unit (control unit) harness connector and the ground.

ABS actuator and electric unit (control unit)		—	Continuity
Connector	Terminal		
E35	3	Ground	Existed
	4		

Is the inspection result normal?

- YES >> GO TO 6.
- NO >> Repair or replace error-detected parts.

6. CHECK TERMINAL

Check the ABS actuator and electric unit (control unit) pin terminals for damage or loose connection with harness connector.

Is the inspection result normal?

- YES >> Replace ABS actuator and electric unit (control unit). Refer to [BRC-138, "Removal and Installation"](#).
- NO >> Repair or replace error-detected parts.

A
B
C
D
E
BRC
G
H
I
J
K
L
M
N
O
P

C1166, C1167 SV SYSTEM

DTC Logic

INFOID:000000009752946

DTC DETECTION LOGIC

DTC	Display Item	Malfunction detected condition	Possible causes
C1166	SV 1	When a malfunction is detected in suction valve 1.	<ul style="list-style-type: none"> Harness or connector ABS actuator and electric unit (control unit) Fusible link Battery power supply system
C1167	SV 2	When a malfunction is detected in suction valve 2.	

DTC CONFIRMATION PROCEDURE

1. PRECONDITIONING

If "DTC CONFIRMATION PROCEDURE" has been previously conducted, always turn ignition switch OFF and wait at least 10 seconds before conducting the next test.

>> GO TO 2.

2. CHECK DTC DETECTION

With CONSULT

1. Turn the ignition switch OFF to ON.
2. Perform self-diagnosis for "ABS".

Is DTC "C1166" or "C1167" detected?

- YES >> Proceed to [BRC-106, "Diagnosis Procedure"](#).
 NO >> INSPECTION END

Diagnosis Procedure

INFOID:000000009752947

1. CHECK CONNECTOR

1. Turn the ignition switch OFF.
2. Check the ABS actuator and electric unit (control unit) harness connector for disconnection or looseness.

Is the inspection result normal?

- YES >> GO TO 3.
 NO >> Repair or replace error-detected parts, securely lock the harness connector, and GO TO 2.

2. PERFORM SELF-DIAGNOSIS

Perform self-diagnosis for "ABS" again.

Is DTC "C1166" or "C1167" detected?

- YES >> GO TO 3.
 NO >> INSPECTION END

3. CHECK SUCTION VALVE POWER SUPPLY

1. Turn the ignition switch OFF.
2. Disconnect ABS actuator and electric unit (control unit) harness connector.
3. Check the voltage between ABS actuator and electric unit (control unit) harness connector and ground.

ABS actuator and electric unit (control unit)		—	Voltage
Connector	Terminal		
E35	2	Ground	Battery voltage

4. Turn the ignition switch ON.

CAUTION:

Never start engine.

5. Check the voltage between ABS actuator and electric unit (control unit) harness connector and ground.

< DTC/CIRCUIT DIAGNOSIS >

ABS actuator and electric unit (control unit)		—	Voltage
Connector	Terminal		
E35	2	Ground	Battery voltage

Is the inspection result normal?

- YES >> GO TO 5.
- NO >> GO TO 4.

4.CHECK SUCTION VALVE POWER SUPPLY CIRCUIT

1. Turn the ignition switch OFF.
2. Check the 50A fusible link (I).
3. Check the continuity and short circuit between ABS actuator and electric unit (control unit) harness connector terminal (2) and 50A fusible link (I).

Is the inspection result normal?

- YES >> Perform trouble diagnosis for battery power supply. Refer to [PG-11, "Wiring Diagram - BATTERY POWER SUPPLY -"](#).
- NO >> Repair or replace error-detected parts.

5.CHECK SUCTION VALVE GROUND CIRCUIT

1. Turn the ignition switch OFF.
2. Check the continuity between ABS actuator and electric unit (control unit) harness connector and the ground.

ABS actuator and electric unit (control unit)		—	Continuity
Connector	Terminal		
E35	3	Ground	Existed
	4		

Is the inspection result normal?

- YES >> GO TO 6.
- NO >> Repair or replace error-detected parts.

6.CHECK TERMINAL

Check the ABS actuator and electric unit (control unit) pin terminals for damage or loose connection with harness connector.

Is the inspection result normal?

- YES >> Replace ABS actuator and electric unit (control unit). Refer to [BRC-138, "Removal and Installation"](#).
- NO >> Repair or replace error-detected parts.

A
B
C
D
E
G
H
I
J
K
L
M
N
O
P

BRC

C1176 STOP LAMP SW2

< DTC/CIRCUIT DIAGNOSIS >

[WITH VDC]

C1176 STOP LAMP SW2

DTC Logic

INFOID:000000009752948

DTC DETECTION LOGIC

DTC	Display item	Malfunction detected condition	Possible cause
C1176	STOP LAMP SW2	When brake pedal position switch signal is not input when brake pedal operates.	<ul style="list-style-type: none">• Harness or connector• Brake pedal position switch• ABS actuator and electric unit (control unit)• Ignition power supply system

DTC CONFIRMATION PROCEDURE

1. PRECONDITIONING

If "DTC CONFIRMATION PROCEDURE" has been previously conducted, always turn ignition switch OFF and wait at least 10 seconds before conducting the next test.

>> GO TO 2.

2. CHECK DTC DETECTION

Ⓟ With CONSULT

1. Turn the ignition switch OFF, and wait 10 seconds or more.
2. Start the engine.

CAUTION:

Never start the vehicle.

3. Depress the brake pedal several times.
4. Perform self-diagnosis for "ABS".

Is DTC "C1176" detected?

- YES >> Proceed to [BRC-108, "Diagnosis Procedure"](#).
NO >> INSPECTION END

Diagnosis Procedure

INFOID:000000009752949

NOTE:

DTC "C1176" may be detected when the brake pedal and the accelerator pedal are simultaneously depressed for 1 minute or more while driving the vehicle. This is not a malfunction.

1. INTERVIEW FROM THE CUSTOMER

Check if the brake pedal and the accelerator pedal are simultaneously depressed for 1 minute or more while driving the vehicle.

Is there such a history?

- YES >> GO TO 2.
NO >> GO TO 3.

2. PERFORM SELF-DIAGNOSIS

Ⓟ With CONSULT

1. Erase self-diagnosis result for "ABS".
2. Turn the ignition switch OFF, and wait 10 seconds or more.
3. Start the engine.

CAUTION:

Never start the vehicle.

4. Depress the brake pedal several times.
5. Perform self-diagnosis for "ABS".

Is DTC "C1176" detected?

- YES >> GO TO 3.
NO >> INSPECTION END

< DTC/CIRCUIT DIAGNOSIS >

3. CHECK BRAKE PEDAL POSITION SWITCH CLEARANCE

1. Turn the ignition switch OFF.
2. Check the brake pedal position switch clearance. Refer to [BR-7, "Inspection and Adjustment"](#).

Is the inspection result normal?

YES >> GO TO 5.

NO >> Adjust brake pedal position switch clearance. Refer to [BR-7, "Inspection and Adjustment"](#). GO TO 4.**4. CHECK DATA MONITOR (1)**

Ⓜ With CONSULT

1. Erase self-diagnosis result for "ABS".
2. Turn the ignition switch OFF, and wait 10 seconds or more.
3. Start the engine.

CAUTION:**Never start the vehicle.**

4. Select "ABS", "DATA MONITOR" and "STOP LAMP SW2" according to this order. Check that data monitor displays "On" or "Off" when brake pedal is depress or release. Refer to [BRC-44, "Reference Value"](#).

Is the inspection result normal?

YES >> INSPECTION END

NO >> GO TO 5.

5. CHECK BRAKE PEDAL POSITION SWITCHCheck the brake pedal position switch. Refer to [BRC-90, "Component Inspection"](#).Is the inspection result normal?

YES >> GO TO 7.

NO >> Replace brake pedal position switch. Refer to [BR-18, "Removal and Installation"](#). GO TO 6.**6. CHECK DATA MONITOR (2)**

Ⓜ With CONSULT

1. Erase self-diagnosis result for "ABS".
2. Turn the ignition switch OFF, and wait 10 seconds or more.
3. Start the engine.

CAUTION:**Never start the vehicle.**

4. Select "ABS", "DATA MONITOR" and "STOP LAMP SW2" according to this order. Check that data monitor displays "On" or "Off" when brake pedal is depress or release. Refer to [BRC-44, "Reference Value"](#).

Is the inspection result normal?

YES >> INSPECTION END

NO >> GO TO 7.

7. CHECK CONNECTOR AND TERMINAL

1. Turn the ignition switch OFF.
2. Disconnect ABS actuator and electric unit (control unit) harness connector.
3. Check the ABS actuator and electric unit (control unit) harness connector for disconnection or looseness.
4. Check the ABS actuator and electric unit (control unit) pin terminals for damage or loose connection with harness connector.
5. Disconnect brake pedal position switch harness connector.
6. Check the brake pedal position switch harness connector for disconnection or looseness.
7. Check the brake pedal position switch pin terminals for damage or loose connection with harness connector.

Is the inspection result normal?

YES >> GO TO 9.

NO >> Repair or replace error-detected parts. GO TO 8.

8. CHECK DATA MONITOR (3)

Ⓜ With CONSULT

1. Connect ABS actuator and electric unit (control unit) harness connector.

C1176 STOP LAMP SW2

[WITH VDC]

< DTC/CIRCUIT DIAGNOSIS >

2. Connect brake pedal position switch harness connector.
3. Erase self-diagnosis result for "ABS".
4. Turn the ignition switch OFF, and wait 10 seconds or more.
5. Start the engine.

CAUTION:

Never start the vehicle.

6. Select "ABS", "DATA MONITOR" and "STOP LAMP SW2" according to this order. Check that data monitor displays "On" or "Off" when brake pedal is depress or release. Refer to [BRC-44, "Reference Value"](#).

Is the inspection result normal?

- YES >> INSPECTION END
 NO >> GO TO 11.

9. CHECK BRAKE PEDAL POSITION SWITCH CIRCUIT (1)

1. Turn the ignition switch OFF.
2. Disconnect ABS actuator and electric unit (control unit) harness connector.
3. Check the voltage between ABS actuator and electric unit (control unit) harness connector and ground.

ABS actuator and electric unit (control unit)		—	Condition	Voltage
Connector	Terminal			
E35	6	Ground	Brake pedal depressed	Approx. 0 V
			Brake pedal not depressed	

4. Turn the ignition switch ON.
5. Check the voltage between ABS actuator and electric unit (control unit) harness connector and ground.

ABS actuator and electric unit (control unit)		—	Condition	Voltage
Connector	Terminal			
E35	6	Ground	Brake pedal depressed	Approx. 0 V
			Brake pedal not depressed	Battery voltage

Is the inspection result normal?

- YES >> Replace ABS actuator and electric unit (control unit). Refer to [BRC-138, "Removal and Installation"](#).
 NO >> Repair or replace error-detected parts. GO TO 10.

10. CHECK BRAKE PEDAL POSITION SWITCH CIRCUIT (2)

1. Turn the ignition switch OFF.
2. Disconnect brake pedal position switch harness connector.
3. Check the continuity between ABS actuator and electric unit (control unit) harness connector and brake pedal position switch harness connector.

ABS actuator and electric unit (control unit)		Brake pedal position switch		Continuity
Connector	Terminal	Connector	Terminal	
E35	6	E112	2	Existed

4. Check the continuity between ABS actuator and electric unit (control unit) harness connector and the ground.

ABS actuator and electric unit (control unit)		—	Continuity
Connector	Terminal		
E35	6	Ground	Not existed

Is the inspection result normal?

- YES >> Replace ABS actuator and electric unit (control unit). Refer to [BRC-138, "Removal and Installation"](#).
 NO >> Repair or replace error-detected parts. GO TO 11.

C1176 STOP LAMP SW2

< DTC/CIRCUIT DIAGNOSIS >

[WITH VDC]

11.CHECK DATA MONITOR (4)

④ With CONSULT

1. Connect ABS actuator and electric unit (control unit) harness connector.
2. Connect brake pedal position switch harness connector.
3. Erase self-diagnosis result for "ABS".
4. Turn the ignition switch OFF, and wait 10 seconds or more.
5. Start the engine.

CAUTION:

Never start the vehicle.

6. Select "ABS", "DATA MONITOR" and "STOP LAMP SW2" according to this order. Check that data monitor displays "On" or "Off" when brake pedal is depress or release. Refer to [BRC-44. "Reference Value"](#).

Is the inspection result normal?

YES >> INSPECTION END

NO >> Replace ABS actuator and electric unit (control unit). Refer to [BRC-138. "Removal and Installation"](#).

Component Inspection

INFOID:000000009752950

BRC

1.CHECK BRAKE PEDAL POSITION SWITCH

1. Turn ignition switch OFF.
2. Disconnect brake pedal position switch harness connector.
3. Check the continuity between brake pedal position switch connector terminals.

Brake pedal position switch Terminal	Condition	Continuity
1 - 2	Brake pedal is fully released.	Not existed
	Brake pedal is slightly depressed.	Existed

Is the inspection result normal?

YES >> INSPECTION END

NO >> Replace brake pedal position switch. Refer to [BR-18. "Removal and Installation"](#).

U1000 CAN COMM CIRCUIT

< DTC/CIRCUIT DIAGNOSIS >

[WITH VDC]

U1000 CAN COMM CIRCUIT

Description

INFOID:000000009752951

CAN (Controller Area Network) is a serial communication line for real time application. It is an on-vehicle multiplex communication line with high data communication speed and excellent error detection ability. Many electronic control units are equipped onto a vehicle, and each control unit shares information and links with other control units during operation (not independent). In CAN communication, control units are connected with 2 communication lines (CAN-H line, CAN-L line) allowing a high rate of information transmission with less wiring. Each control unit transmits/receives data but selectively reads required data only.

DTC Logic

INFOID:000000009752952

DTC DETECTION LOGIC

DTC	Display Item	Malfunction detected condition	Possible causes
U1000	CAN COMM CIRCUIT	When CAN communication signal is not continuously transmitted or received for 2 seconds or more.	CAN communication system malfunction

DTC CONFIRMATION PROCEDURE

1. PRECONDITIONING

If "DTC CONFIRMATION PROCEDURE" has been previously conducted, always turn ignition switch OFF and wait at least 10 seconds before conducting the next test.

>> GO TO 2.

2. CHECK DTC DETECTION

④ With CONSULT

1. Turn the ignition switch OFF to ON.
2. Perform self-diagnosis for "ABS".

Is DTC "U1000" detected?

- YES >> Proceed to [BRC-112. "Diagnosis Procedure"](#).
NO >> INSPECTION END

Diagnosis Procedure

INFOID:000000009752953

Proceed to [LAN-15. "Trouble Diagnosis Flow Chart"](#).

U1010 CONTROL UNIT (CAN)

< DTC/CIRCUIT DIAGNOSIS >

[WITH VDC]

U1010 CONTROL UNIT (CAN)

Description

INFOID:000000009752954

CAN (Controller Area Network) is a serial communication line for real time application. It is an on-vehicle multiplex communication line with high data communication speed and excellent error detection ability. Many electronic control units are equipped onto a vehicle, and each control unit shares information and links with other control units during operation (not independent). In CAN communication, control units are connected with 2 communication lines (CAN-H line, CAN-L line) allowing a high rate of information transmission with less wiring. Each control unit transmits/receives data but selectively reads required data only.

DTC Logic

INFOID:000000009752955

DTC DETECTION LOGIC

DTC	Display item	Malfunction detected condition	Possible causes
U1010	CONTROL UNIT (CAN)	When detecting error during the initial diagnosis of CAN controller of ABS actuator and electric unit (control unit).	ABS actuator and electric unit (control unit)

A
B
C
D
E
BRC

DTC CONFIRMATION PROCEDURE

1. PRECONDITIONING

If "DTC CONFIRMATION PROCEDURE" has been previously conducted, always turn ignition switch OFF and wait at least 10 seconds before conducting the next test.

>> GO TO 2.

2. CHECK DTC DETECTION

④ With CONSULT

1. Turn the ignition switch OFF to ON.
2. Perform self-diagnosis for "ABS".

Is DTC "U1010" detected?

YES >> Proceed to [BRC-113, "Diagnosis Procedure"](#).

NO >> INSPECTION END

Diagnosis Procedure

INFOID:000000009752956

1. CHECK ABS ACTUATOR AND ELECTRIC UNIT (CONTROL UNIT)

Check the ABS actuator and electric unit (control unit) harness connector for disconnection and deformation.

Is the inspection result normal?

YES >> Replace ABS actuator and electric unit (control unit). Refer to [BRC-138, "Removal and Installation"](#).

NO >> Repair or replace error-detected parts.

L
M
N
O
P

POWER SUPPLY AND GROUND CIRCUIT

[WITH VDC]

< DTC/CIRCUIT DIAGNOSIS >

POWER SUPPLY AND GROUND CIRCUIT

Diagnosis Procedure

INFOID:000000009752957

1. CHECK ABS ACTUATOR AND ELECTRIC UNIT (CONTROL UNIT) IGNITION POWER SUPPLY

1. Turn the ignition switch OFF.
2. Disconnect ABS actuator and electric unit (control unit) harness connector.
3. Check the voltage between ABS actuator and electric unit (control unit) harness connector and ground.

ABS actuator and electric unit (control unit)		—	Voltage
Connector	Terminal		
E35	16	Ground	Approx. 0 V

4. Turn the ignition switch ON

CAUTION:

Never start engine.

5. Check the voltage between ABS actuator and electric unit (control unit) harness connector and ground.

ABS actuator and electric unit (control unit)		—	Voltage
Connector	Terminal		
E35	16	Ground	10 – 16 V

Is the inspection result normal?

YES >> GO TO 3.

NO >> GO TO 2.

2. CHECK ABS ACTUATOR AND ELECTRIC UNIT (CONTROL UNIT) IGNITION POWER SUPPLY CIRCUIT

1. Turn the ignition switch OFF.
2. Check the 10A fuse (#57).
3. Disconnect IPDM E/R harness connector.
4. Check the continuity between ABS actuator and electric unit (control unit) harness connector and IPDM E/R harness connector.

ABS actuator and electric unit (control unit)		IPDM E/R		Continuity
Connector	Terminal	Connector	Terminal	
E35	16	E15	59	Existed

5. Check the continuity between ABS actuator and electric unit (control unit) harness connector and the ground.

ABS actuator and electric unit (control unit)		—	Continuity
Connector	Terminal		
E35	16	Ground	Not existed

Is the inspection result normal?

YES >> Perform trouble diagnosis for ignition power supply. Refer to [PG-41. "Wiring Diagram - IGNITION POWER SUPPLY -"](#).

NO >> Repair or replace error-detected parts.

3. CHECK MOTOR AND MOTOR RELAY POWER SUPPLY

1. Turn the ignition switch OFF.
2. Check the voltage between ABS actuator and electric unit (control unit) harness connector and ground.

ABS actuator and electric unit (control unit)		—	Voltage
Connector	Terminal		
E35	1	Ground	10 – 16 V

POWER SUPPLY AND GROUND CIRCUIT

[WITH VDC]

< DTC/CIRCUIT DIAGNOSIS >

- Turn the ignition switch ON.

CAUTION:

Never start engine.

- Check the voltage between ABS actuator and electric unit (control unit) harness connector and ground.

ABS actuator and electric unit (control unit)		—	Voltage
Connector	Terminal		
E35	1	Ground	10 – 16 V

Is the inspection result normal?

YES >> GO TO 5.

NO >> GO TO 4.

4.CHECK MOTOR AND MOTOR RELAY POWER SUPPLY CIRCUIT

- Turn the ignition switch OFF.
- Check the 30A fusible link (K).
- Check the continuity and short circuit between ABS actuator and electric unit (control unit) harness connector terminal (1) and 30A fusible link (K).

Is the inspection result normal?

YES >> Perform trouble diagnosis for battery power supply. Refer to [PG-11, "Wiring Diagram - BATTERY POWER SUPPLY -"](#).

NO >> Repair or replace error-detected parts.

5.CHECK ACTUATOR RELAY, ABS IN VALVE, ABS OUT VALVE POWER SUPPLY

- Turn the ignition switch OFF.
- Check the voltage between ABS actuator and electric unit (control unit) harness connector and ground.

ABS actuator and electric unit (control unit)		—	Voltage
Connector	Terminal		
E35	2	Ground	10 – 16 V

- Turn the ignition switch ON

CAUTION:

Never start engine.

- Check the voltage between ABS actuator and electric unit (control unit) harness connector and ground.

ABS actuator and electric unit (control unit)		—	Voltage
Connector	Terminal		
E35	2	Ground	10 – 16 V

Is the inspection result normal?

YES >> GO TO 7.

NO >> GO TO 6.

6.CHECK ACTUATOR RELAY, ABS IN VALVE, ABS OUT VALVE POWER SUPPLY CIRCUIT

- Turn the ignition switch OFF.
- Check the 50A fusible link (I).
- Check the continuity and short circuit between ABS actuator and electric unit (control unit) harness connector terminal (2) and 50A fusible link (I).

Is the inspection result normal?

YES >> Perform trouble diagnosis for battery power supply. Refer to [PG-11, "Wiring Diagram - BATTERY POWER SUPPLY -"](#).

NO >> Repair or replace error-detected parts.

7.CHECK ABS ACTUATOR AND ELECTRIC UNIT (CONTROL UNIT) GROUND CIRCUIT

Check the continuity between ABS actuator and electric unit (control unit) harness connector and the ground.

POWER SUPPLY AND GROUND CIRCUIT

[WITH VDC]

< DTC/CIRCUIT DIAGNOSIS >

ABS actuator and electric unit (control unit)		—	Continuity
Connector	Terminal		
E35	3	Ground	Existed
	4		

Is the inspection result normal?

YES >> GO TO 8.

NO >> Repair or replace error-detected parts.

8.CHECK TERMINAL

- Check the ABS actuator and electric unit (control unit) pin terminals for damage or loose connection with harness connector.
- Check the IPDM E/R pin terminals for damage or loose connection with harness connector.

Is the inspection result normal?

YES >> INSPECTION END

NO >> Repair or replace error-detected parts.

PARKING BRAKE SWITCH

< DTC/CIRCUIT DIAGNOSIS >

[WITH VDC]

PARKING BRAKE SWITCH

Component Function Check

INFOID:000000009752958

1.CHECK PARKING BRAKE SWITCH OPERATION

Operate the parking brake lever. Then check that the brake warning lamp in the combination meter turns ON/OFF correctly.

Is the inspection result normal?

- YES >> INSPECTION END
- NO >> Proceed to [BRC-117, "Diagnosis Procedure"](#).

Diagnosis Procedure

INFOID:000000009752959

1.CHECK PARKING BRAKE SWITCH CIRCUIT

1. Turn the ignition switch OFF.
2. Disconnect parking brake switch harness connector.
3. Disconnect combination meter harness connector.
4. Check the continuity between parking brake switch harness connector and combination meter harness connector.

Parking brake switch		Combination meter		Continuity
Connector	Terminal	Connector	Terminal	
M31	1	M34	10	Existed

5. Check the continuity between parking brake switch harness connector and ground.

Parking brake switch		—	Continuity
Connector	Terminal		
M31	1	Ground	Not existed

Is the inspection result normal?

- YES >> GO TO 2.
- NO >> Repair or replace error-detected parts.

2.CHECK PARKING BRAKE SWITCH

Check the parking brake switch. Refer to [BRC-117, "Component Inspection"](#).

Is the inspection result normal?

- YES >> GO TO 3.
- NO >> Replace parking brake switch. Refer to [PB-6, "Removal and Installation"](#).

3.CHECK COMBINATION METER

Check the combination meter. Refer to [MWI-21, "CONSULT Function"](#).

Is the inspection result normal?

- YES >> Check the each pin terminals for damage or loose connection with harness connector. If any items are damaged, repair or replace error-detected parts.
- NO >> Repair or replace combination meter. Refer to [MWI-61, "Removal and Installation"](#).

Component Inspection

INFOID:000000009752960

1.CHECK PARKING BRAKE SWITCH

1. Turn the ignition switch OFF.
2. Disconnect parking brake switch harness connector.
3. Check the continuity between parking brake switch connector terminal and ground.

PARKING BRAKE SWITCH

< DTC/CIRCUIT DIAGNOSIS >

[WITH VDC]

Parking brake switch		Condition	Continuity
Terminal	—	When the parking brake switch is operated.	Existed
1	Ground	When the parking brake switch is not operated.	Not existed

Is the inspection result normal?

YES >> INSPECTION END

NO >> Replace parking brake switch. Refer to [PB-6. "Removal and Installation"](#).

VDC OFF SWITCH

< DTC/CIRCUIT DIAGNOSIS >

[WITH VDC]

VDC OFF SWITCH

Component Function Check

INFOID:000000009752961

1. CHECK VDC OFF SWITCH OPERATION

Check that VDC OFF indicator lamp in combination meter turns ON/OFF when VDC OFF switch is operated.

Is the inspection result normal?

YES >> INSPECTION END

NO >> Proceed to diagnosis procedure. Refer to [BRC-119, "Diagnosis Procedure"](#).

Diagnosis Procedure

INFOID:000000009752962

1. CHECK VDC OFF SWITCH CIRCUIT

1. Turn the ignition switch OFF.
2. Disconnect ABS actuator and electric unit (control unit) harness connector.
3. Disconnect VDC OFF switch harness connector.
4. Check the continuity between ABS actuator and electric unit (control unit) harness connector and VDC OFF switch harness connector.

ABS actuator and electric unit (control unit)		VDC OFF switch		Continuity
Connector	Terminal	Connector	Terminal	
E35	5	M28	1	Existed

5. Check the continuity between ABS actuator and electric unit (control unit) harness connector and ground.

ABS actuator and electric unit (control unit)		—	Continuity
Connector	Terminal		
E35	5	Ground	Not existed

Is the inspection result normal?

YES >> GO TO 2.

NO >> Repair or replace error-detected parts.

2. CHECK VDC OFF SWITCH GROUND CIRCUIT

Check the continuity between VDC OFF switch harness connector and ground.

VDC OFF switch		—	Continuity
Connector	Terminal		
M28	2	Ground	Existed

Is the inspection result normal?

YES >> GO TO 3.

NO >> Repair or replace error-detected parts.

3. CHECK VDC OFF SWITCH

Check the VDC OFF switch. Refer to [BRC-120, "Component Inspection"](#).

Is the inspection result normal?

YES >> GO TO 4.

NO >> Replace VDC OFF switch. Refer to [BRC-142, "Removal and Installation"](#).

4. CHECK VDC OFF SWITCH SIGNAL

Ⓜ With CONSULT

1. Connect ABS actuator and electric unit (control unit) harness connector.
2. Connect VDC OFF switch harness connector.

VDC OFF SWITCH

[WITH VDC]

< DTC/CIRCUIT DIAGNOSIS >

3. Select "ABS", "DATA MONITOR" and "OFF SW" according to this order. Check the VDC OFF switch signal.

Condition	DATA MONITOR
When VDC OFF switch is pressed and VDC OFF indicator lamp in combination meter is in ON status	On
When VDC OFF switch is pressed and VDC OFF indicator lamp in combination meter is in OFF status	Off

Is the inspection result normal?

- YES >> INSPECTION END
NO >> GO TO 5.

5.CHECK TERMINAL

- Check the ABS actuator and electric unit (control unit) pin terminals for damage or loose connection with harness connector.
- Check the VDC OFF switch pin terminals for damage or loose connection with harness connector.

Is the inspection result normal?

- YES >> Replace ABS actuator and electric unit (control unit). Refer to [BRC-138, "Removal and Installation"](#).
NO >> Repair or replace error-detected parts.

Component Inspection

INFOID:000000009752963

1.CHECK VDC OFF SWITCH

1. Turn the ignition switch OFF.
2. Disconnect triple switch harness connector.
3. Check the continuity between VDC OFF switch connector terminals.

VDC OFF switch Terminal	Condition	Continuity
1 – 2	When VDC OFF switch is pressed	Existed
	When VDC OFF switch is not pressed	Not existed

Is the inspection result normal?

- YES >> INSPECTION END
NO >> Replace VDC OFF switch. Refer to [BRC-142, "Removal and Installation"](#).

ABS WARNING LAMP

[WITH VDC]

< DTC/CIRCUIT DIAGNOSIS >

ABS WARNING LAMP

Component Function Check

INFOID:000000009752964

1. CHECK ABS WARNING LAMP FUNCTION

Check that ABS warning lamp in combination meter turns ON for approx. 1 second after ignition switch is turned ON.

CAUTION:

Never start engine.

Is the inspection result normal?

- YES >> INSPECTION END
- NO >> Proceed to [BRC-121, "Diagnosis Procedure"](#).

Diagnosis Procedure

INFOID:000000009752965

1. CHECK ABS ACTUATOR AND ELECTRIC UNIT (CONTROL UNIT) POWER SUPPLY AND GROUND CIRCUIT

Perform the trouble diagnosis for ABS actuator and electric unit (control unit) power supply and ground circuit. Refer to [BRC-114, "Diagnosis Procedure"](#).

Is the inspection result normal?

- YES >> GO TO 2.
- NO >> Repair or replace error-detected parts.

2. PERFORM SELF-DIAGNOSIS

 With CONSULT

Perform self-diagnosis for "ABS".

Is any DTC detected?

- YES >> Check the DTC. Refer to [BRC-50, "DTC Index"](#).
- NO >> GO TO 3.

3. CHECK ABS WARNING LAMP SIGNAL

 With CONSULT

1. Select "ABS", "DATA MONITOR" and "ABS WARN LAMP" according to this order.
2. Turn the ignition switch OFF.
3. Check that data monitor displays "On" for approx. 1 second after ignition switch is turned ON and then changes to "Off".

CAUTION:

Never start engine.

Is the inspection result normal?

- YES >> Check the combination meter. Refer to [MWI-21, "CONSULT Function"](#).
- NO >> Replace ABS actuator and electric unit (control unit). Refer to [BRC-138, "Removal and Installation"](#).

A
B
C
D
E
BRC
G
H
I
J
K
L
M
N
O
P

BRAKE WARNING LAMP

Component Function Check

INFOID:000000009752966

1. CHECK BRAKE WARNING LAMP FUNCTION (1)

Check that brake warning lamp in combination meter turns ON for approx. 1 second after ignition switch is turned ON.

CAUTION:

Never start engine.

Is the inspection result normal?

- YES >> GO TO 2.
- NO >> Proceed to [BRC-122, "Diagnosis Procedure"](#).

2. CHECK BRAKE WARNING LAMP FUNCTION (2)

Check that brake warning lamp in combination meter turns ON/OFF when parking brake is operated.

NOTE:

Brake warning lamp turns ON when parking brake is operated (when parking brake switch is ON).

Is the inspection result normal?

- YES >> GO TO 3.
- NO >> Check the parking brake switch system. Refer to [BRC-117, "Diagnosis Procedure"](#).

3. CHECK BRAKE WARNING LAMP FUNCTION (3)

Check that brake warning lamp in combination meter turns ON/OFF when brake fluid level switch is operated while brake fluid level in reservoir tank is with the specified level.

NOTE:

Brake warning lamp turns ON when brake fluid is less than the specified level (when brake fluid level switch is ON).

Is the inspection result normal?

- YES >> INSPECTION END
- NO >> Check the brake fluid level switch system. Refer to [BRC-101, "Diagnosis Procedure"](#).

Diagnosis Procedure

INFOID:000000009752967

1. CHECK ABS ACTUATOR AND ELECTRIC UNIT (CONTROL UNIT) POWER SUPPLY AND GROUND CIRCUIT

Perform the trouble diagnosis for ABS actuator and electric unit (control unit) power supply and ground circuit. Refer to [BRC-114, "Diagnosis Procedure"](#).

Is the inspection result normal?

- YES >> GO TO 2.
- NO >> Repair or replace error-detected parts.

2. PERFORM SELF-DIAGNOSIS

Ⓢ With CONSULT

Perform self-diagnosis for "ABS".

Is any DTC detected?

- YES >> Check the DTC. Refer to [BRC-50, "DTC Index"](#).
- NO >> GO TO 3.

3. CHECK COMBINATION METER

Check the combination meter. Refer to [MWI-21, "CONSULT Function"](#).

Is the inspection result normal?

- YES >> Replace ABS actuator and electric unit (control unit). Refer to [BRC-138, "Removal and Installation"](#).
- NO >> Repair or replace combination meter. Refer to [MWI-61, "Removal and Installation"](#).

VDC WARNING LAMP

[WITH VDC]

< DTC/CIRCUIT DIAGNOSIS >

VDC WARNING LAMP

Component Function Check

INFOID:000000009752968

1. CHECK VDC WARNING LAMP FUNCTION

Check that VDC warning lamp in combination meter turns ON for approx. 1 second after ignition switch is turned ON.

CAUTION:

Never start engine.

Is the inspection result normal?

YES >> INSPECTION END

NO >> Proceed to diagnosis procedure. Refer to [BRC-123, "Diagnosis Procedure"](#).

Diagnosis Procedure

INFOID:000000009752969

1. CHECK ABS ACTUATOR AND ELECTRIC UNIT (CONTROL UNIT) POWER SUPPLY AND GROUND CIRCUIT

Perform the trouble diagnosis for ABS actuator and electric unit (control unit) power supply and ground circuit. Refer to [BRC-114, "Diagnosis Procedure"](#).

Is the inspection result normal?

YES >> GO TO 2.

NO >> Repair or replace error-detected parts.

2. PERFORM SELF-DIAGNOSIS

 With CONSULT

Perform self-diagnosis for "ABS".

Is any DTC detected?

YES >> Check the DTC. Refer to [BRC-50, "DTC Index"](#).

NO >> GO TO 3.

3. CHECK VDC WARNING LAMP SIGNAL

 With CONSULT

1. Select "ABS", "DATA MONITOR" and "SLIP/VDC LAMP" according to this order.

2. Turn the ignition switch OFF.

3. Check that data monitor displays "On" for approx. 1 second after ignition switch is turned ON, and then changes to "Off".

CAUTION:

Never start engine.

Is the inspection result normal?

YES >> Check the combination meter. Refer to [MWI-21, "CONSULT Function"](#).

NO >> Replace ABS actuator and electric unit (control unit). Refer to [BRC-138, "Removal and Installation"](#).

A
B
C
D
E
BRC
G
H
I
J
K
L
M
N
O
P

VDC OFF INDICATOR LAMP

Component Function Check

INFOID:000000009752970

1. CHECK VDC OFF INDICATOR LAMP FUNCTION (1)

Check that VDC OFF indicator lamp in combination meter turns ON for approx. 1 second after ignition switch is turned ON.

CAUTION:

Never start engine.

Is the inspection result normal?

YES >> GO TO 2.

NO >> Proceed to diagnosis procedure. Refer to [BRC-124, "Diagnosis Procedure"](#).

2. CHECK VDC OFF INDICATOR LAMP FUNCTION (2)

Check that VDC OFF indicator lamp in combination meter turns ON/OFF when VDC OFF switch is operated.

Is the inspection result normal?

YES >> INSPECTION END

NO >> Check the VDC OFF switch system. Refer to [BRC-119, "Diagnosis Procedure"](#).

Diagnosis Procedure

INFOID:000000009752971

1. CHECK ABS ACTUATOR AND ELECTRIC UNIT (CONTROL UNIT) POWER SUPPLY AND GROUND CIRCUIT

Perform the trouble diagnosis for ABS actuator and electric unit (control unit) power supply and ground circuit. Refer to [BRC-114, "Diagnosis Procedure"](#).

Is the inspection result normal?

YES >> GO TO 2.

NO >> Repair or replace error-detected parts.

2. CHECK VDC OFF INDICATOR LAMP SIGNAL (1)

Ⓜ With CONSULT

1. Select "ABS", "DATA MONITOR" and "OFF LAMP" according to this order.

2. Turn the ignition switch OFF.

3. Check that data monitor displays "On" for approx. 1 second after ignition switch is turned ON, and then changes to "Off".

CAUTION:

Never start engine.

Is the inspection result normal?

YES >> GO TO 3.

NO >> Replace ABS actuator and electric unit (control unit). Refer to [BRC-138, "Removal and Installation"](#).

3. CHECK VDC OFF INDICATOR LAMP SIGNAL (2)

Ⓜ With CONSULT

1. Select "ABS", "DATA MONITOR" and "OFF LAMP" according to this order.

2. Check that data monitor displays "On" or "Off" each time when VDC OFF switch is operated.

Is the inspection result normal?

YES >> Check the combination meter. Refer to [MWI-21, "CONSULT Function"](#).

NO >> Check the VDC OFF switch system. Refer to [BRC-142, "Removal and Installation"](#).

EXCESSIVE OPERATION FREQUENCY

[WITH VDC]

< SYMPTOM DIAGNOSIS >

SYMPTOM DIAGNOSIS

EXCESSIVE OPERATION FREQUENCY

Description

INFOID:000000009752972

VDC function, TCS function, ABS function, EBD function and brake limited slip differential (BLSD) function operates in excessive operation frequency.

Diagnosis Procedure

INFOID:000000009752973

1. CHECK BRAKING FORCE

Check the brake force using a brake tester.

Is the inspection result normal?

YES >> GO TO 2.

NO >> Check the brake system.

2. CHECK FRONT AND REAR AXLE

Check that there is no excessive looseness in front and rear axle.

- Front axle: Refer to [FAX-7. "Inspection"](#).
- Rear axle
 - 2WD: Refer to [RAX-6. "Inspection"](#).
 - AWD: Refer to [RAX-14. "Inspection"](#).

Is the inspection result normal?

YES >> GO TO 3.

NO >> Repair or replace error-detected parts.

3. CHECK WHEEL SENSOR

Check the wheel sensor.

- Check installation and damage of wheel sensor.
- Check connection of wheel sensor harness connector.
- Check terminal of wheel sensor harness connector.

Is the inspection result normal?

YES >> GO TO 4.

NO >> Repair or replace wheel sensor.

- Front wheel sensor: Refer to [BRC-132. "FRONT WHEEL SENSOR : Removal and Installation"](#).
- Rear wheel sensor: Refer to [BRC-135. "REAR WHEEL SENSOR : Removal and Installation"](#).

4. CHECK SENSOR ROTOR

Check that there is no looseness, damage or foreign material on sensor rotor.

Is the inspection result normal?

YES >> GO TO 5.

NO >> Repair installation or replace sensor rotor.

- Front sensor rotor: Refer to [BRC-137. "FRONT SENSOR ROTOR : Removal and Installation"](#).
- Rear sensor rotor. Refer to [BRC-137. "REAR SENSOR ROTOR : Removal and Installation"](#).

5. CHECK WARNING LAMP TURNS OFF

Check that ABS warning lamp, brake warning lamp and VDC warning lamp turn OFF approx. 1 second after key switch is turned ON and stay in OFF status during driving.

CAUTION:

Brake warning lamp turns ON when parking brake is operated (parking brake switch is ON) or brake fluid is less than the specified level (brake fluid level switch is ON).

Is the inspection result normal?

YES >> Normal

NO >> Perform self-diagnosis for "ABS" with CONSULT.

A

B

C

D

E

BRC

G

H

I

J

K

L

M

N

O

P

UNEXPECTED BRAKE PEDAL REACTION

[WITH VDC]

< SYMPTOM DIAGNOSIS >

UNEXPECTED BRAKE PEDAL REACTION

Description

INFOID:000000009752974

A malfunction of brake pedal feel (height or others) is detected when brake pedal is depressed.

Diagnosis Procedure

INFOID:000000009752975

1.CHECK FRONT AND REAR AXLE

Check that there is no excessive looseness in front and rear axle.

- Front axle: Refer to [FAX-7, "Inspection"](#).
- Rear axle
 - 2WD: Refer to [RAX-6, "Inspection"](#).
 - AWD: Refer to [RAX-14, "Inspection"](#).

Is the inspection result normal?

- YES >> GO TO 2.
NO >> Repair or replace error-detected parts.

2.CHECK DISC ROTOR

Check the disc rotor runout.

- Front: Refer to [BR-14, "DISC ROTOR : Inspection and Adjustment"](#).
- Rear: Refer to [BR-16, "DISC ROTOR : Inspection and Adjustment"](#).

Is the inspection result normal?

- YES >> GO TO 3.
NO >> Refinish disc rotor.
 - Front: Refer to [BR-14, "DISC ROTOR : Inspection and Adjustment"](#).
 - Rear: Refer to [BR-16, "DISC ROTOR : Inspection and Adjustment"](#).

3.CHECK BRAKE FLUID LEAKAGE

Check the fluid leakage.

- Front: Refer to [BR-24, "FRONT : Inspection"](#).
- Rear: Refer to [BR-32, "REAR : Inspection"](#).

Is the inspection result normal?

- YES >> GO TO 4.
NO >> Repair or replace error-detected parts.

4.CHECK BRAKE PEDAL

Check the each item of brake pedal. Refer to [BR-7, "Inspection and Adjustment"](#).

Is the inspection result normal?

- YES >> GO TO 5.
NO >> Adjust each item of brake pedal. Refer to [BR-7, "Inspection and Adjustment"](#).

5.CHECK BRAKING FORCE

Check the brake force using a brake tester.

Is the inspection result normal?

- YES >> GO TO 6.
NO >> Check the each components of brake system.

6.CHECK BRAKE PERFORMANCE

Disconnect ABS actuator and electric unit (control unit) harness connector so that ABS does not operate. Check that brake force is normal in this condition. Connect harness connectors after checking.

Is the inspection result normal?

- YES >> Normal
NO >> Check the each components of brake system.

THE BRAKING DISTANCE IS LONG

[WITH VDC]

< SYMPTOM DIAGNOSIS >

THE BRAKING DISTANCE IS LONG

Description

INFOID:000000009752976

Brake stopping distance is long when ABS function is operated.

Diagnosis Procedure

INFOID:000000009752977

CAUTION:

Brake stopping distance on slippery road like rough road, gravel road or snowy road may become longer when ABS is operated than when ABS is not operated.

1.CHECK BRAKING FORCE

Check the brake force using a brake tester.

Is the inspection result normal?

YES >> GO TO 2.

NO >> Check the each components of brake system.

2.CHECK BRAKE PERFORMANCE

Disconnect ABS actuator and electric unit (control unit) harness connector so that ABS does not operate. Check the brake stopping distance in this condition. Connect harness connectors after checking.

Is the inspection result normal?

YES >> Normal

NO >> Check the each components of brake system.

A
B
C
D
E
BRC
G
H
I
J
K
L
M
N
O
P

DOES NOT OPERATE

[WITH VDC]

< SYMPTOM DIAGNOSIS >

DOES NOT OPERATE

Description

INFOID:000000009752978

VDC function, TCS function, ABS function, EBD function and brake limited slip differential (BLSD) function does not operate.

Diagnosis Procedure

INFOID:000000009752979

CAUTION:

- VDC function, TCS function, ABS function, EBD function and brake limited slip differential (BLSD) function never operate when the vehicle speed is 10 km/h (6.2 MPH) or less.
- VDC function and TCS function never operate when VDC OFF switch is operated (when VDC OFF indicator lamp turns ON).

1. CHECK WARNING LAMP

Check that ABS warning lamp, brake warning lamp and VDC warning lamp turn ON and turn OFF approx. 1 second after key switch is turned ON. Check that ABS warning lamp, brake warning lamp and VDC warning lamp and stay in OFF status during driving.

CAUTION:

Brake warning lamp turns ON when parking brake is operated (parking brake switch is ON) or brake fluid is less than the specified level (brake fluid level switch is ON).

Is the inspection result normal?

- YES >> Normal
NO >> Perform self-diagnosis for "ABS" with CONSULT.

BRAKE PEDAL VIBRATION OR OPERATION SOUND OCCURS

< SYMPTOM DIAGNOSIS >

[WITH VDC]

BRAKE PEDAL VIBRATION OR OPERATION SOUND OCCURS

Description

INFOID:000000009752980

- Brake pedal vibrates and motor sound from ABS actuator and electric unit (control unit) occurs, when the engine starts.
- Brake pedal vibrates during braking.

CAUTION:

Vibration may be felt during brake pedal is lightly depressed (just placing a foot on it) in the following conditions. This is normal.

- When shifting gears
- When driving on slippery road
- During cornering at high speed
- When passing over bumps or grooves [Approx. 50 mm (1.97 in) or more]
- When pulling away just after starting engine [at approx. 10 km/h (6.2 MPH) or higher]

Diagnosis Procedure

INFOID:000000009752981

1. SYMPTOM CHECK 1

Check that there are pedal vibrations when the engine is started.

Do vibrations occur?

YES >> GO TO 2.

NO >> Check brake pedal. Refer to [BR-19, "Inspection and Adjustment"](#).

2. SYMPTOM CHECK 2

Check that motor noise from ABS actuator and electric unit (control unit) occurs when the engine starts.

Does the operation sound occur?

YES >> GO TO 3.

NO >> Perform self-diagnosis for "ABS" with CONSULT.

3. SYMPTOM CHECK 3

Check symptoms when electrical component (headlamps, etc.) switches are operated.

Does the symptom occur?

YES >> Check that radio (including wiring), antenna and antenna lead-in wires are not located near ABS actuator and electric unit (control unit). Move them if they are located near ABS actuator and electric unit (control unit).

NO >> Normal

A
B
C
D
E
G
H
I
J
K
L
M
N
O
P

BRC

VEHICLE JERKS DURING

Description

INFOID:000000009752982

The vehicle jerks when VDC function, TCS function, ABS function, EBD function or brake limited slip differential (BLSD) function operates.

Diagnosis Procedure

INFOID:000000009752983

1.CHECK SYMPTOM

Check that the vehicle jerks when VDC function, TCS function, ABS function, EBD function or brake limited slip differential (BLSD) function operates.

Is the inspection result normal?

- YES >> Normal
- NO >> GO TO 2.

2.PERFORM SELF-DIAGNOSIS

 With CONSULT

Perform self-diagnosis for "ABS".

Is any DTC detected?

- YES >> Check the DTC. Refer to [BRC-50, "DTC Index"](#).
- NO >> GO TO 3.

3.CHECK CONNECTOR

 With CONSULT

1. Turn the ignition switch OFF.
2. Disconnect ABS actuator and electric unit (control unit) harness connector.
3. Check connector terminal for deformation, disconnection and looseness.
4. Connect harness connector and perform self-diagnosis for "ABS" again.

Is the inspection result normal?

- YES >> GO TO 4.
- NO >> Poor connection of connector terminal. Repair or replace connector terminal.

4.CHECK ECM AND TCM SELF-DIAGNOSIS RESULTS

 With CONSULT

Perform self-diagnosis for "ENGINE" and "TRANSMISSION" (for CVT models).

Is any DTC detected?

- YES >> Check the DTC.
- NO >> Replace ABS actuator and electric unit (control unit). Refer to [BRC-138, "Removal and Installation"](#).

NORMAL OPERATING CONDITION

< SYMPTOM DIAGNOSIS >

[WITH VDC]

NORMAL OPERATING CONDITION

Description

INFOID:000000009752984

Symptom	Result
Brake pedal slightly vibrates and operation sound (motor sound and sound from suspension) occurs when VDC function, TCS function, ABS function, EBD function or brake limited differential (BLSD) function operates.	This is not a malfunction, The symptom occurs VDC function, TCS function, ABS function, EBD function and brake limited differential (BLSD) function that are normally operated.
Brake stopping distance may become longer than models without ABS function depending on the road conditions, when ABS function is operated on slippery road like rough road, gravel road or snowy road.	
Brake pedal vibrates and operation sound occurs during sudden acceleration and cornering, when VDC function, TCS function or brake limited slip differential (BLSD) function is operated.	
Brake pedal vibrates and motor sound from the engine room occurs, when the engine starts or the vehicle starts just after starting the engine.	This is not a malfunction, because it is caused by operation check of ABS actuator and electric unit (control unit).
Acceleration may be felt insufficient depending on the road conditions.	This is not a malfunction, because it is caused by TCS function that puts the highest priority to obtain the optimum traction (stability).
TCS function may operate momentarily, while driving on a road where friction coefficient varies, or when downshifting, or fully depressing accelerator pedal.	
ABS warning lamp and VDC OFF indicator lamp may turn ON, when the vehicle is on a rotating turntable or is given a strong shaking or large vibrations on a ship while the engine is running.	In this case, restart the engine on a normal road. If the normal condition is restored, there is no malfunction. In that case, erase "ABS" self-diagnosis result memory with CONSULT.
VDC warning lamp may turn ON and VDC function, TCS function and brake limited slip differential (BLSD) function may not normally operate, when driving on a special road the is extremely slanted (bank in a circuit course).	
A malfunction in yaw rate/side/decel G sensor system may be detected when the vehicle sharply turns during a spin turn, acceleration turn or drift driving while VDC function, TCS function and brake limited slip differential (BLSD) function are OFF (VDC OFF switch is pressed and VDC OFF indicator lamp is in ON status).	
The vehicle speed does not increase, when the accelerator pedal is depressed while the vehicle is on a 2-wheel chassis dynamometer for speedometer check.	This is not a malfunction. (When checking the vehicle on a chassis dynamometer, operate VDC OFF switch so that TCS function is OFF.)

A
B
C
D
E
BRC
G
H
I
J
K
L
M
N
O
P

WHEEL SENSOR

< REMOVAL AND INSTALLATION >

[WITH VDC]

REMOVAL AND INSTALLATION

WHEEL SENSOR

FRONT WHEEL SENSOR

FRONT WHEEL SENSOR : Exploded View

INFOID:000000009752985

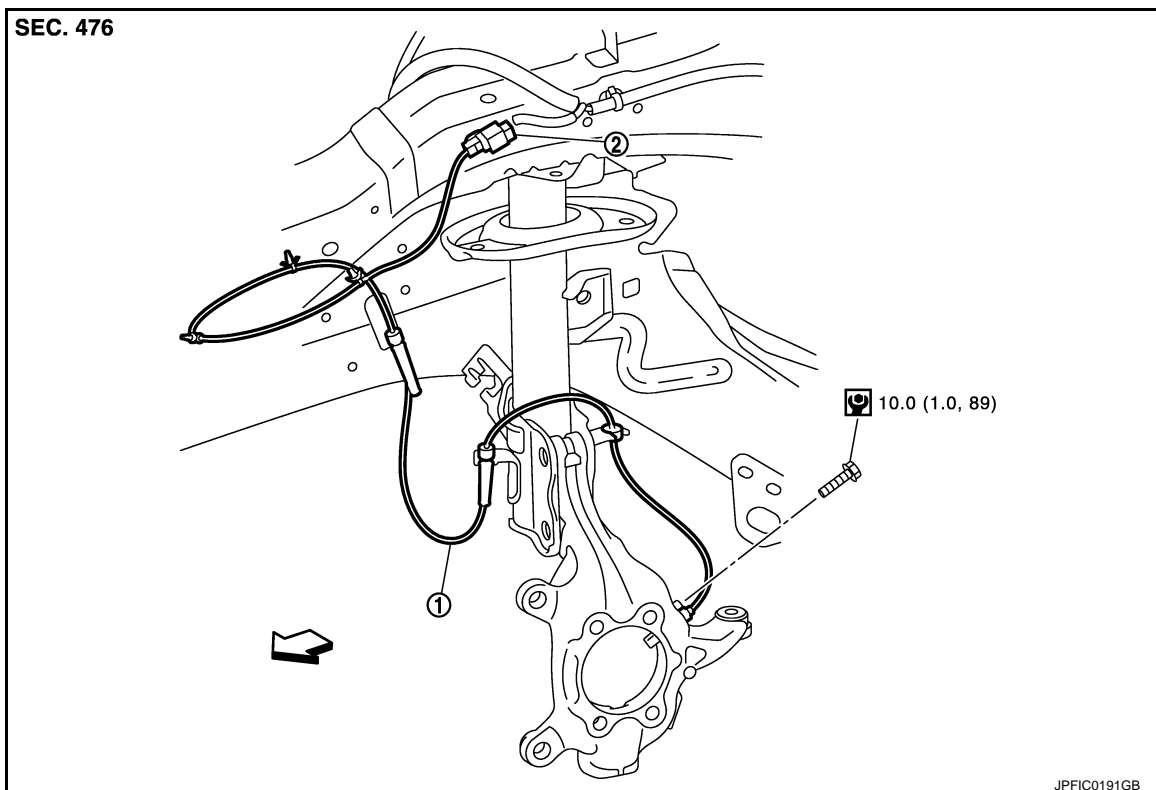

1. Front LH wheel sensor

2. Front LH wheel sensor harness connector

⇐: Vehicle front

🔧: N·m (kg·m, in·lb)

NOTE:

Front RH wheel sensor is symmetrically opposite of LH.

FRONT WHEEL SENSOR : Removal and Installation

INFOID:000000009752986

REMOVAL

1. Remove tires.
2. Remove the fender protector (front). Refer to [EXT-27, "Removal and Installation"](#).
3. Remove front wheel sensor from steering knuckle.

CAUTION:

Never rotate and never pull front wheel sensor as much as possible, when pulling out.

4. Remove front wheel sensor harness from the vehicle.

CAUTION:

Never twist or pull front wheel sensor harness, when removing.

INSTALLATION

Note the following, and install in the reverse order of the removal.

WHEEL SENSOR

< REMOVAL AND INSTALLATION >

[WITH VDC]

- Check that there is no foreign material like iron powder or damage on inner surface of front wheel sensor mounting hole of steering knuckle and sensor rotor. Install after cleaning when there are foreign material like iron powder, or replace when there is a malfunction.
- Never twist front wheel sensor harness when installing front wheel sensor. Check that grommet (2) is fully inserted to bracket (1). Check that front wheel sensor harness is not twisted after installation.

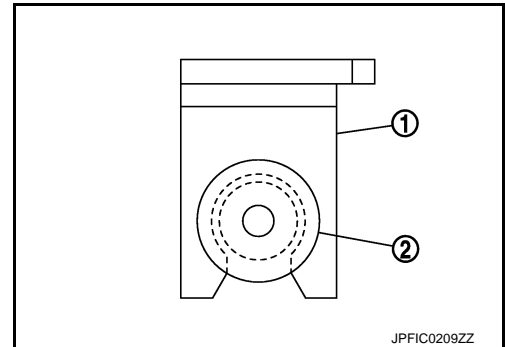

REAR WHEEL SENSOR

REAR WHEEL SENSOR : Exploded View

INFOID:000000009752987

2WD

BRC

Left side

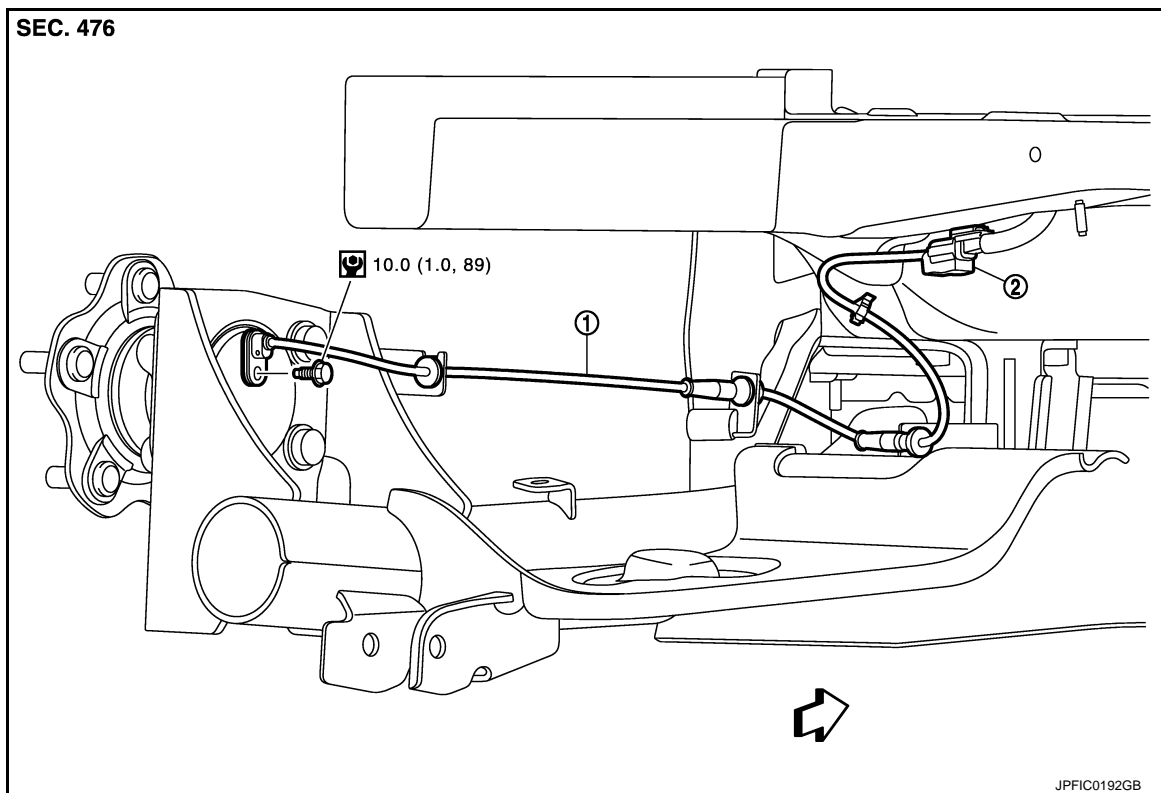

1. Rear LH wheel sensor

2. Rear LH wheel sensor harness connector

←: Vehicle front

: N·m (kg-m, in-lb)

WHEEL SENSOR

< REMOVAL AND INSTALLATION >

[WITH VDC]

Right side

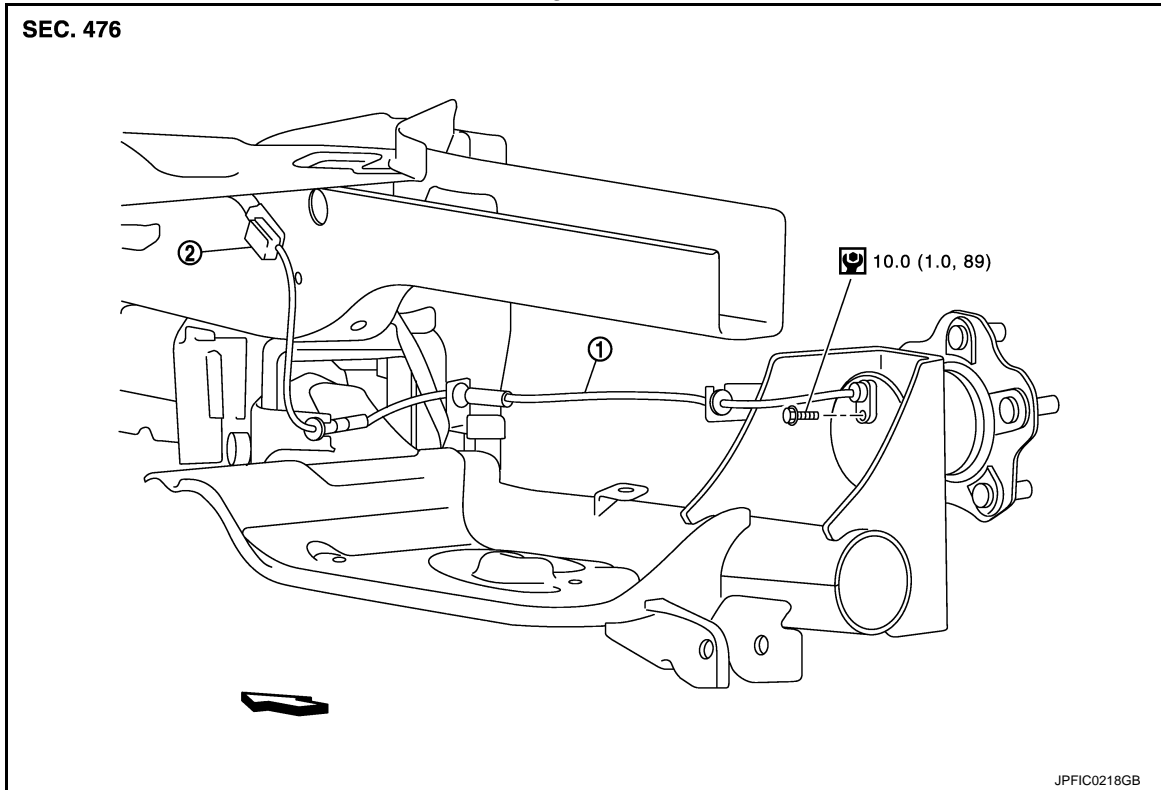

1. Rear RH wheel sensor

2. Rear RH wheel sensor harness connector

←: Vehicle front

🔧: N·m (kg·m, in·lb)

AWD

WHEEL SENSOR

< REMOVAL AND INSTALLATION >

[WITH VDC]

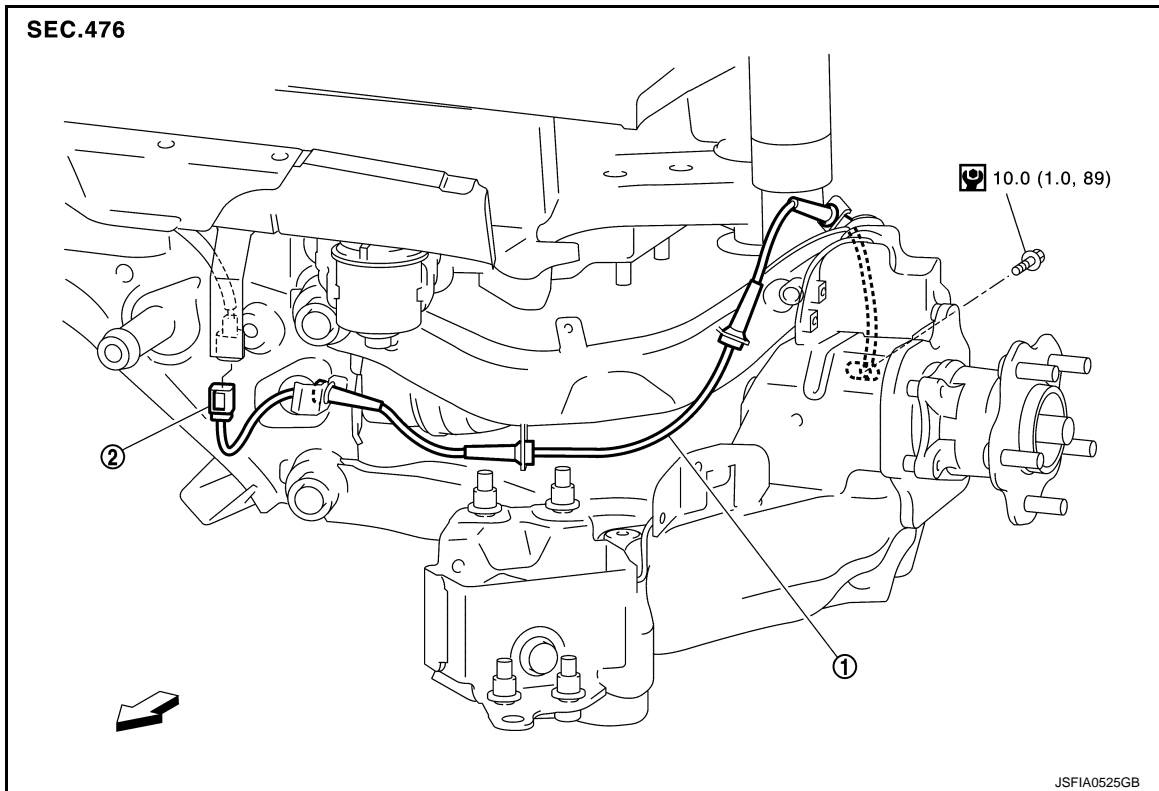

1. Rear LH wheel sensor
2. Rear LH wheel sensor harness connector

←: Vehicle front

: N·m (kg·m, in·lb)

NOTE:

Rear RH wheel sensor is symmetrically opposite of LH.

REAR WHEEL SENSOR : Removal and Installation

INFOID:000000009752988

REMOVAL

1. Remove rear wheel sensor from wheel hub and bearing assembly (2WD).
CAUTION:
Never rotate or pull rear wheel sensor as much as possible, when pulling out.
2. Remove rear wheel sensor from axle housing (AWD).
CAUTION:
Never rotate or pull rear wheel sensor as much as possible, when pulling out.
3. Remove rear wheel sensor harness from the vehicle.
CAUTION:
Never twist and never pull rear wheel sensor harness, when removing.

INSTALLATION

Note the following, and install in the reverse order of the removal.

- Check that there is no foreign material like iron powder or damage on inner surface of rear wheel sensor mounting hole of wheel hub and bearing assembly and sensor rotor. Install after cleaning when there are foreign material like iron powder, or replace when there is a malfunction.

WHEEL SENSOR

< REMOVAL AND INSTALLATION >

[WITH VDC]

- Never twist rear wheel sensor harness when installing rear wheel sensor. Check that grommet (2) is fully inserted to bracket (1). Check that rear wheel sensor harness is not twisted after installation.

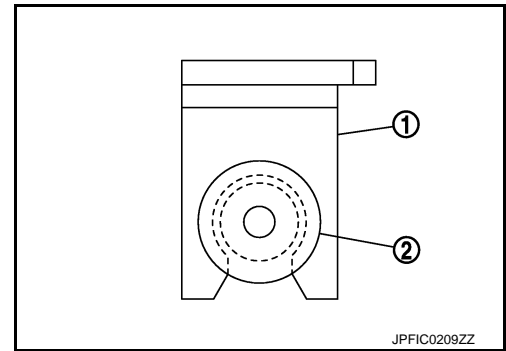

CAUTION:

Check that the identification line (A) of the rear wheel sensor is faced upward.

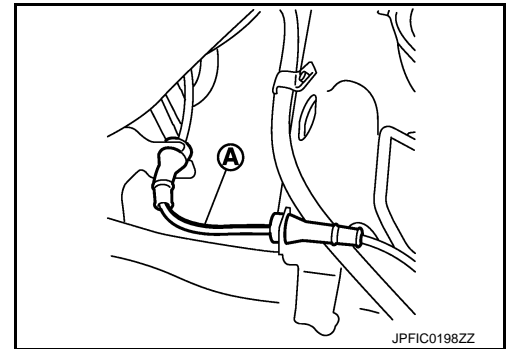

SENSOR ROTOR

< REMOVAL AND INSTALLATION >

[WITH VDC]

SENSOR ROTOR

FRONT SENSOR ROTOR

FRONT SENSOR ROTOR : Removal and Installation

INFOID:000000009752989

REMOVAL

Replace wheel hub as an assembly when replacing because sensor rotor cannot be disassembled. Refer to [FAX-9, "Removal and Installation"](#).

INSTALLATION

Replace wheel hub as an assembly when replacing because sensor rotor cannot be disassembled. Refer to [FAX-9, "Removal and Installation"](#).

REAR SENSOR ROTOR

REAR SENSOR ROTOR : Removal and Installation

INFOID:000000009752990

REMOVAL

2WD

Replace wheel hub as an assembly when replacing because sensor rotor cannot be disassembled. Refer to [RAX-7, "Removal and Installation"](#).

AWD

1. Remove drive shaft. Refer to [RAX-19, "Removal and Installation"](#).
2. Remove sensor rotor from drive shaft. Refer to [RAX-20, "WHEEL SIDE : Disassembly and Assembly"](#).

INSTALLATION

Note the following, and install in the reverse order of the removal.

- Never reuse sensor rotor. (AWD)

A

B

C

D

E

BRC

G

H

I

J

K

L

M

N

O

P

ABS ACTUATOR AND ELECTRIC UNIT (CONTROL UNIT)

< REMOVAL AND INSTALLATION >

[WITH VDC]

ABS ACTUATOR AND ELECTRIC UNIT (CONTROL UNIT)

Exploded View

INFOID:000000009752991

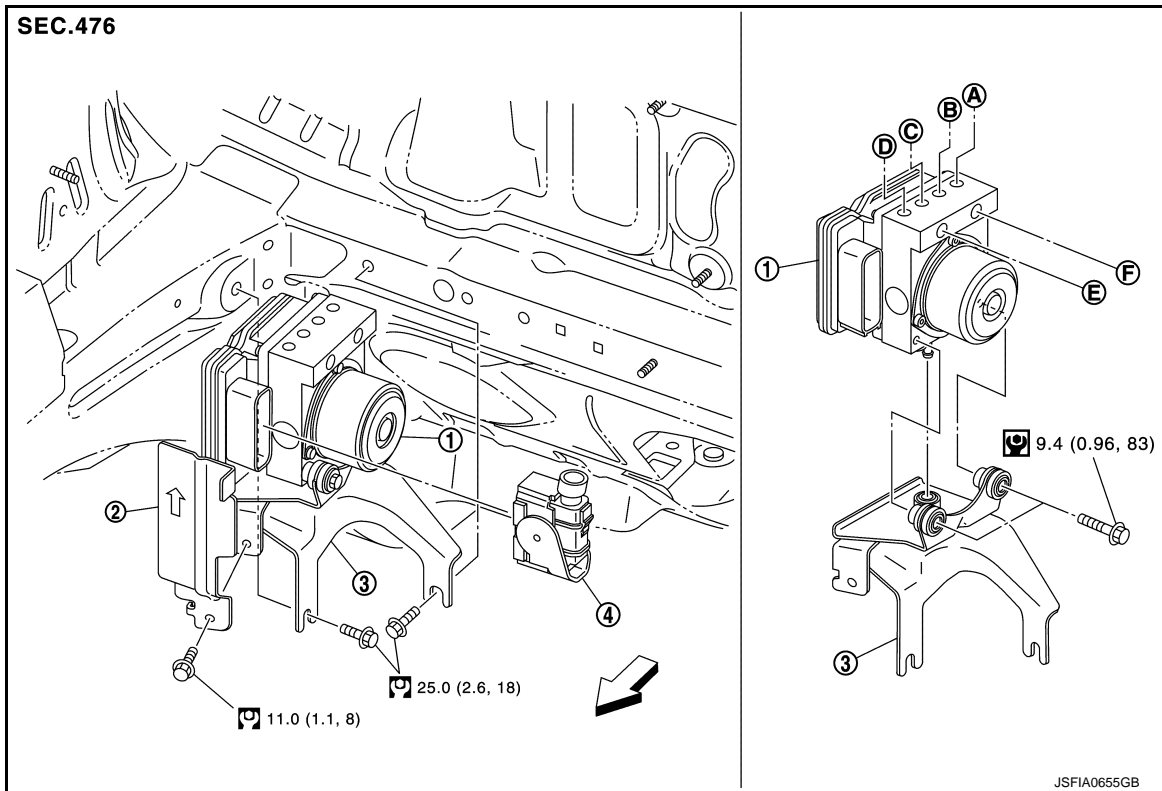

- | | | |
|--|--------------------------------------|------------------------------------|
| 1. ABS actuator and electric unit (control unit) | 2. Bracket A | 3. Bracket B |
| 4. ABS actuator and electric unit (control unit) harness connector | | |
| A. To front LH caliper | B. To rear RH caliper | C. To rear LH caliper |
| D. To front RH caliper | E. To master cylinder secondary side | F. To master cylinder primary side |

←: Vehicle front

: N·m (kg·m, ft·lb)

: N·m (kg·m, in·lb)

Removal and Installation

INFOID:000000009752992

REMOVAL

1. Disconnect battery cable from negative terminal.
2. Drain brake fluid. Refer to [BR-10, "Draining"](#).
3. Remove bracket A.

ABS ACTUATOR AND ELECTRIC UNIT (CONTROL UNIT)

[WITH VDC]

< REMOVAL AND INSTALLATION >

4. Disconnect ABS actuator and electric unit (control unit) harness connector (1), follow the procedure described below.
 - a. Push the pawl (A).
 - b. Move the lever (B) in the direction (C) until locked.
 - c. Disconnect ABS actuator and electric unit (control unit) harness connector.
5. Loosen flare nut of brake tube using a flare nut wrench, and then remove brake tube from ABS actuator and electric unit (control unit). Refer to [BR-21, "FRONT : Exploded View"](#).
6. Remove ABS actuator and electric unit (control unit) and bracket B.

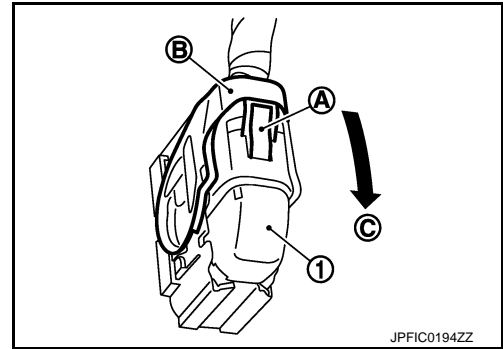

CAUTION:

- Never remove and never install ABS actuator and electric unit (control unit) by holding harness connector.
- Be careful not to drop ABS actuator and electric unit (control unit) and apply excessive impact to it.

7. Remove bracket B and bushing from ABS actuator and electric unit (control unit).

INSTALLATION

Note the following, and install in the reverse order of removal.

- When replacing with a new ABS actuator and electric unit (control unit), never remove the protector of the brake tube mounting hole until right before the brake tube is installed.
- When installing brake tube, tighten to the specified torque using a crowfoot and torque wrench so that flare nut and brake tube are not damaged. Refer to [BR-21, "FRONT : Exploded View"](#).
- Never remove and install ABS actuator and electric unit (control unit) by holding actuator harness.
- Bleed air from brake piping after installation. Refer to [BR-11, "Bleeding Brake System"](#).
- Never apply excessive impact to actuator, such as by dropping it.
- After installing the ABS actuator and electric unit (control unit) harness connector (1), move the lever (A) in the direction (B) to secure the locking.
- Perform steering angle sensor neutral position adjustment when ABS actuator and electric unit (control unit) is replaced. Refer to [BRC-62, "Work Procedure"](#).

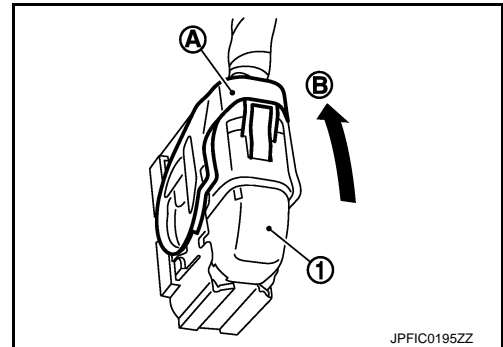

A
B
C
D
E
BRC
G
H
I
J
K
L
M
N
O
P

YAW RATE/SIDE/DECEL G SENSOR

< REMOVAL AND INSTALLATION >

[WITH VDC]

YAW RATE/SIDE/DECEL G SENSOR

Exploded View

INFOID:000000009752993

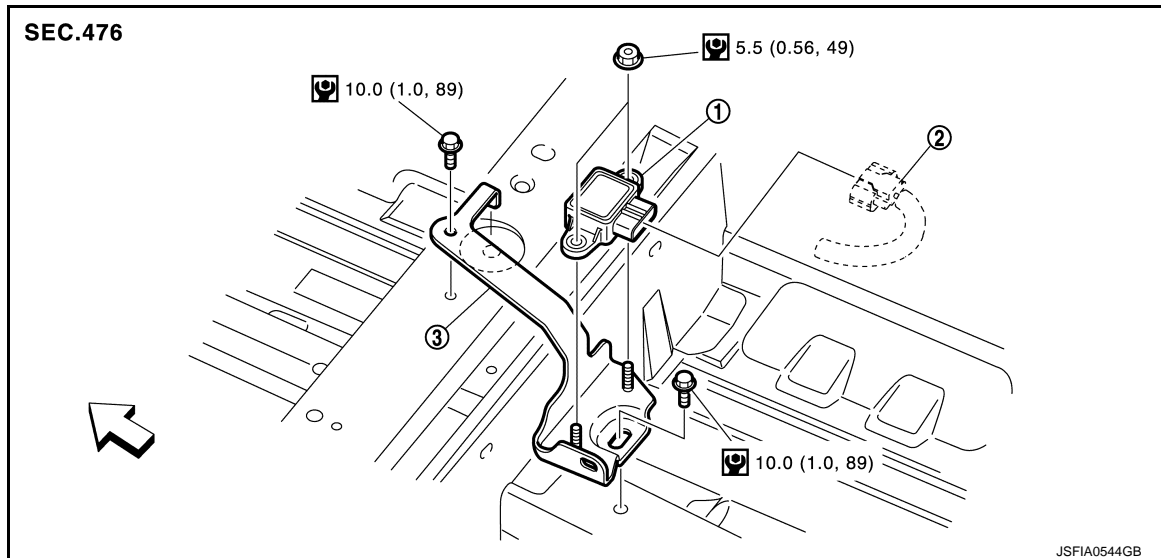

1. Yaw rate/side/decel G sensor
2. Yaw rate/side/decel G sensor harness connector
3. Bracket

↔: Vehicle front

🔧: N-m (kg-m, in-lb)

Removal and Installation

INFOID:000000009752994

REMOVAL

CAUTION:

Never drop or strike yaw rate/side/decel G sensor, because it has little endurance to impact. Never use a pneumatic tool.

1. Remove front seat (right side). Refer to [SE-20, "Removal and Installation"](#).
2. Remove floor carpet. Refer to [INT-24, "Removal and Installation"](#).
3. Disconnect yaw rate/side/decel G sensor harness connector.
4. Remove yaw rate/side/decel G sensor.

INSTALLATION

Note the following, and install in the reverse order of removal.

- Never drop or strike yaw rate/transverse/decel G sensor, because it has little endurance to impact. Never use a power tool.

STEERING ANGLE SENSOR

[WITH VDC]

< REMOVAL AND INSTALLATION >

STEERING ANGLE SENSOR

Removal and Installation

INFOID:000000009752995

REMOVAL

1. Remove spiral cable assembly. Refer to [SR-14, "Removal and Installation"](#).
2. Remove steering angle sensor.

INSTALLATION

Note the following, and install in the reverse order of removal.

- Perform steering angle sensor neutral position adjustment when steering angle sensor is removed and installed, or replaced. Refer to [BRC-62, "Work Procedure"](#).

A
B
C
D
E
G
H
I
J
K
L
M
N
O
P

BRC

VDC OFF SWITCH

< REMOVAL AND INSTALLATION >

[WITH VDC]

VDC OFF SWITCH

Removal and Installation

INFOID:000000009752996

REMOVAL

1. Remove lower instrument panel. Refer to [IP-13, "Removal and Installation"](#).
2. Remove VDC OFF switch.

INSTALLATION

Installation is the reverse order of removal.