

SECTION **BRM**  
BODY REPAIR

A  
B  
C  
D  
E  
F  
G  
H  
I  
J  
L  
M  
N  
O  
P

CONTENTS

<b>VEHICLE INFORMATION</b> .....	2	Hoodledge .....	34
<b>BODY EXTERIOR PAINT COLOR</b> .....	2	Hoodledge (Partial Replacement) .....	35
Body Exterior Paint Color .....	2	Front Side Member .....	37
<b>PRECAUTION</b> .....	3	Front Side Member (Partial Replacement) .....	39
<b>REPAIRING HIGH STRENGTH STEEL</b> .....	3	Front Pillar .....	41
High Strength Steel (HSS) .....	3	Center Pillar (Standard Roof Models) .....	44
Handling of Ultra High Strength Steel Plate Parts.....	5	Center Pillar (With Sunroof Models) .....	46
<b>PREPARATION</b> .....	6	Outer Sill (Partial Replacement) .....	49
<b>REPAIRING MATERIAL</b> .....	6	Outer Sill .....	50
Foam Repair .....	6	Rear Fender (2WD Models) .....	53
<b>BODY COMPONENT PARTS</b> .....	8	Rear Fender (AWD Models) .....	56
Underbody Component Parts (2WD Models) .....	8	Rear Fender Extension (2WD Models) .....	59
Underbody Component Parts (AWD Models) .....	10	Rear Fender Extension (AWD Models) .....	60
Body Component Parts (2WD Models) .....	12	Rear Panel (2WD Models) .....	61
Body Component Parts (AWD Models) .....	14	Rear Panel (AWD Models) .....	62
<b>REMOVAL AND INSTALLATION</b> .....	17	Rear Floor Rear (2WD Models) .....	62
<b>CORROSION PROTECTION</b> .....	17	Rear Floor Rear (AWD Models) .....	63
Description .....	17	Rear Side Member (AWD Models Partial Replace- ment) .....	64
Anti-corrosive Wax .....	17	Rear Side Member Extension (2WD Models) .....	65
Undercoating (2WD Models) .....	18	Rear Side Member Extension (AWD Models) .....	66
Undercoating (AWD Models) .....	19	<b>SERVICE DATA AND SPECIFICATIONS</b>	
Body Sealing (2WD Models) .....	20	<b>(SDS)</b> .....	68
Body Sealing (AWD Models) .....	24	<b>BODY ALIGNMENT</b> .....	68
<b>BODY CONSTRUCTION</b> .....	27	Body Center Marks .....	68
Body Construction (Standard roof Models) .....	27	Description .....	69
Body Construction (With sunroof Models) .....	29	Engine Compartment .....	69
Rear Fender Hemming Process .....	30	Underbody (2WD Models) .....	72
<b>REPLACEMENT OPERATIONS</b> .....	32	Underbody (AWD Models) .....	74
Description .....	32	Passenger Compartment .....	77
Radiator Core Support .....	34	Rear Body .....	79
		<b>LOCATION OF PLASTIC PARTS</b> .....	81
		Precautions for Plastics .....	81
		Location of Plastic Parts .....	82

BRM

# BODY EXTERIOR PAINT COLOR

< VEHICLE INFORMATION >

## VEHICLE INFORMATION

### BODY EXTERIOR PAINT COLOR

#### Body Exterior Paint Color

INFOID:000000009750245

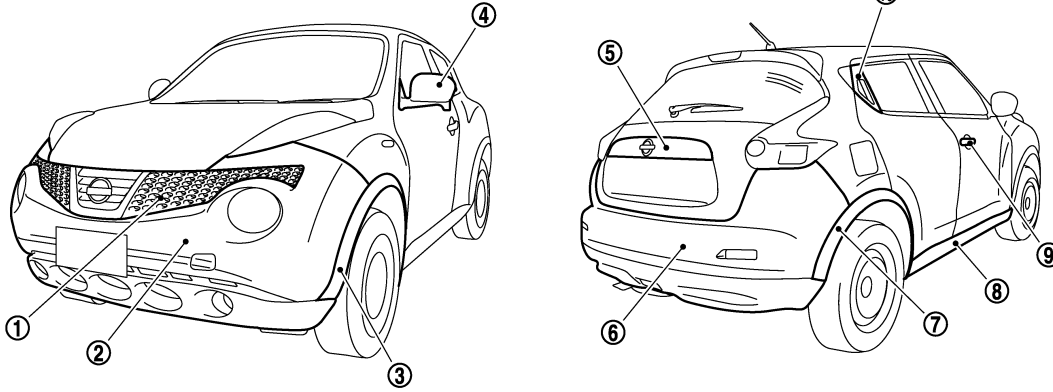

JSKIA2126ZZ

Component			Color code	BB20	BKAD	BK23	BNAH	BQAB	BRAQ	BEAH	BA20	BGAB
			Description	Bluish Black	Gray	Silver	Red	White	Dark Blue	Gold	Red	Black
			Paint type <sup>Note</sup>	2P	2M	2M	2PM	3P	2M	2PM	2S	2P
			Hard clear coat	×	-	-	×	-	×	-	×	×
①	Front grille	Grille	Material color	-	-	-	-	-	-	-	-	-
		Molding	Chromium plate	Cr	Cr	Cr	Cr	Cr	Cr	Cr	Cr	Cr
②	Front bumper fascia	Body color	BB20	BKAD	BK23	BNAH	BQAB	BRAQ	BEAH	BA20	BGAB	
③	Front fillet molding	Material color	-	-	-	-	-	-	-	-	-	
④	Door outside mirror	Body color	BB20	BKAD	BK23	BNAH	BQAB	BRAQ	BEAH	BA20	BGAB	
		Material color	-	-	-	-	-	-	-	-	-	
⑤	Back door finisher	Body color	BB20	BKAD	BK23	BNAH	BQAB	BRAQ	BEAH	BA20	BGAB	
⑥	Rear bumper fascia	Body color	BB20	BKAD	BK23	BNAH	BQAB	BRAQ	BEAH	BA20	BGAB	
⑦	Rear fillet molding	Material color	-	-	-	-	-	-	-	-	-	
⑧	Center mudguard	Material color	-	-	-	-	-	-	-	-	-	
⑨	Front door outside handle	Body color	BB20	BKAD	BK23	BNAH	BQAB	BRAQ	BEAH	BA20	BGAB	
		Material color	-	-	-	-	-	-	-	-	-	
⑩	Rear door outside handle	Material color	-	-	-	-	-	-	-	-	-	

**NOTE:**

- 2M: 2-Coat metallic
- 2P: 2-Coat pearl
- 2S: 2-Coat solid
- 2PM: 2-Coat pearl metallic
- 3P: 3-Coat pearl

# REPAIRING HIGH STRENGTH STEEL

< PRECAUTION >

## PRECAUTION

### REPAIRING HIGH STRENGTH STEEL

#### High Strength Steel (HSS)

INFOID:000000009750246

High strength steel is used for body panels in order to reduce vehicle weight. Accordingly, precautions in repairing automotive bodies made of high strength steel are described below:

Tensile strength	Major applicable parts
440 - 780 MPa	<ul style="list-style-type: none"> <li>• Trans control reinforcement (Center front floor component part)</li> <li>• 2nd crossmember (Front floor component part)</li> <li>• Inner sill</li> <li>• Side dash</li> <li>• Lower dash crossmember (Lower)</li> <li>• Front strut housing</li> <li>• Front side member assembly</li> <li>• Front side member closing plate assembly</li> <li>• Front suspension mounting bracket (Front)</li> <li>• Rear seat crossmember</li> <li>• Rear seat crossmember reinforcement (Rear crossmember center assembly component part)</li> <li>• Rear side member</li> <li>• Rear side member extension</li> <li>• Upper rear seat crossmember</li> <li>• Front side member front assembly</li> <li>• Inner side roof rail</li> <li>• Upper inner front pillar</li> <li>• Inner center pillar</li> <li>• Outer side roof rail reinforcement</li> <li>• Lower center pillar brace</li> <li>• Outer front pillar reinforcement (Front pillar brace component part)</li> <li>• Lower front pillar hinge brace</li> <li>• Outer sill reinforcement</li> <li>• Inner rear pillar reinforcement</li> <li>• Front roof rail</li> <li>• Rear bumper stay assembly</li> </ul>
980 - 1310 MPa	<ul style="list-style-type: none"> <li>• Front side member rear extension (Front floor component part)</li> <li>• Inner sill reinforcement (Inner sill component part)</li> <li>• Lower dash crossmember (Upper) (Lower dash component part)</li> <li>• Inner center front bumper reinforcement</li> <li>• Inner center rear bumper reinforcement</li> </ul>

Read the following precautions when repairing HSS:

1. Additional points to consider

- The repair of reinforcements (such as side members) by heating is not recommended, because it may weaken the component. When heating is unavoidable, never heat HSS parts above 550°C (1,022°F).

Verify heating temperature with a thermometer. (Crayon-type and other similar type thermometer are appropriate.)

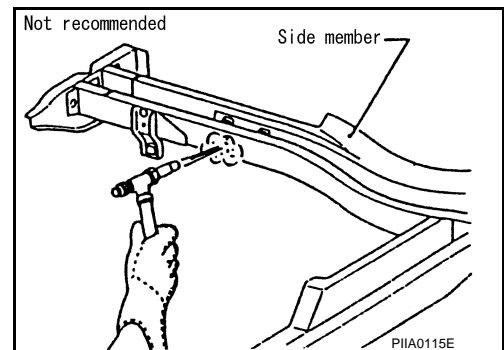

# REPAIRING HIGH STRENGTH STEEL

## < PRECAUTION >

- When straightening body panels, use caution in pulling any HSS panel. Because HSS is very strong, pulling may cause deformation in adjacent sections of the body. In this case, increase the number of measuring points, and carefully pull the HSS panel.

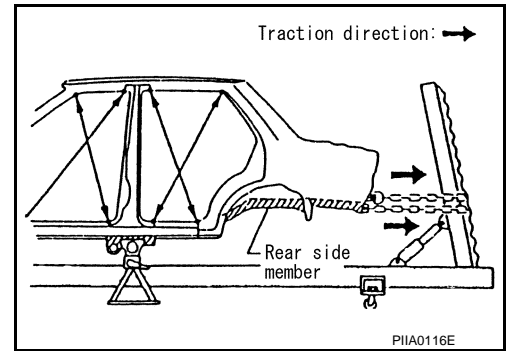

- When cutting HSS panels, avoid gas (torch) cutting if possible. Instead, use a saw to avoid weakening surrounding areas due to heat. If gas (torch) cutting is unavoidable, allow a minimum margin of 50 mm (1.97in).

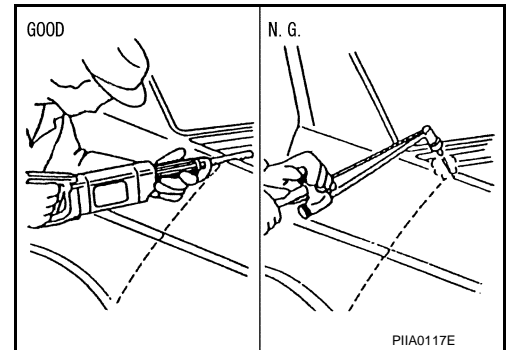

- When welding HSS panels, use spot welding whenever possible in order to minimize weakening surrounding areas due to heat. If spot welding is impossible, use MIG. welding. Do not use gas (torch) for welding because it is inferior in welding strength.

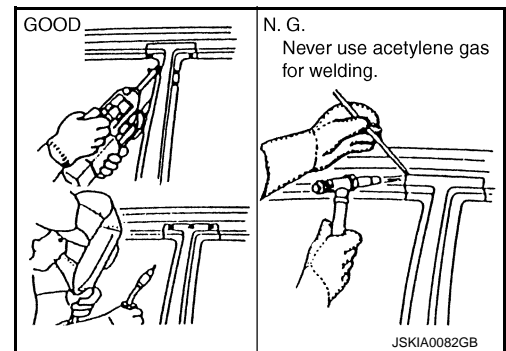

- Spot welding on HSS panels is harder than that of an ordinary steel panel. Therefore, when cutting spot welds on a HSS panel, use a low speed high torque drill (1,000 to 1,200 rpm) to increase drill bit durability and facilitate the operation.

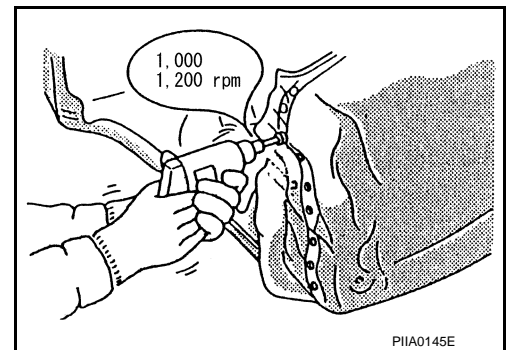

# REPAIRING HIGH STRENGTH STEEL

## < PRECAUTION >

### 2. Precautions in spot welding HSS

This work should be performed under standard working conditions. Always note the following when spot welding HSS:

- The electrode tip diameter must be sized properly according to the metal thickness.

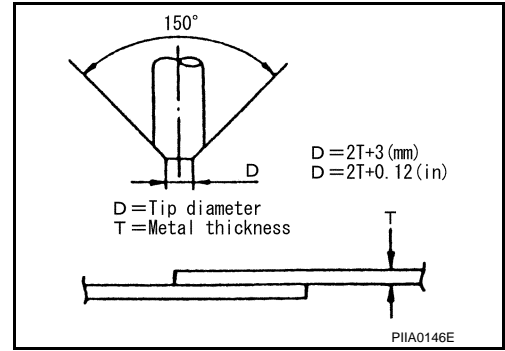

- The panel surfaces must fit flush to each other, leaving no gaps.

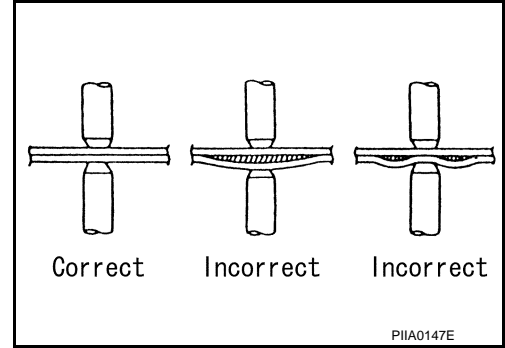

- Follow the specifications for the proper welding pitch.

Unit: mm (in)

Thickness (T)	Minimum pitch (L)
0.6 (0.024)	10 (0.39) or more
0.8 (0.031)	12 (0.47) or more
1.0 (0.039)	18 (0.71) or more
1.2 (0.047)	20 (0.79) or more
1.6 (0.063)	27 (1.06) or more
1.8 (0.071)	31 (1.22) or more

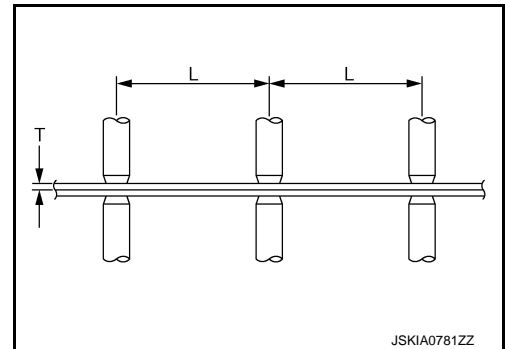

## Handling of Ultra High Strength Steel Plate Parts

INFOID:000000009750247

### PROHIBITION OF CUT AND CONNECTION

Never cut and Joint the stiffener front side member (front floor inside frame parts) because its material is high strength steel plate (ultra high strength steel plate).

The front floor assembly must be replaced if this part is damaged.

A  
B  
C  
D  
E  
F  
G  
H  
I  
J  
BRM  
L  
M  
N  
O  
P

# REPAIRING MATERIAL

< PREPARATION >

## PREPARATION

### REPAIRING MATERIAL

#### Foam Repair

INFOID:000000009750248

During factory body assembly, foam insulators are installed in certain body panels and locations around the vehicle. Use the following procedure(s) to replace any factory-installed foam insulators.

#### URETHANE FOAM APPLICATIONS

Use commercially available Urethane foam for sealant (foam material) repair of material used on vehicle.

<Urethane foam for foaming agent>

**3M™ Automix™ Flexible Foam 08463 or equivalent**

Read instructions on product for fill procedures.

Example of foaming agent filling operation procedure

1. Fill procedures after installation of service part.
  - a. Eliminate foam material remaining on vehicle side.
  - b. Clean area after eliminating form insulator and foam material.
  - c. Install service part.
  - d. Insert nozzle into hole near fill area and fill foam material or fill enough to close gap with the service part.

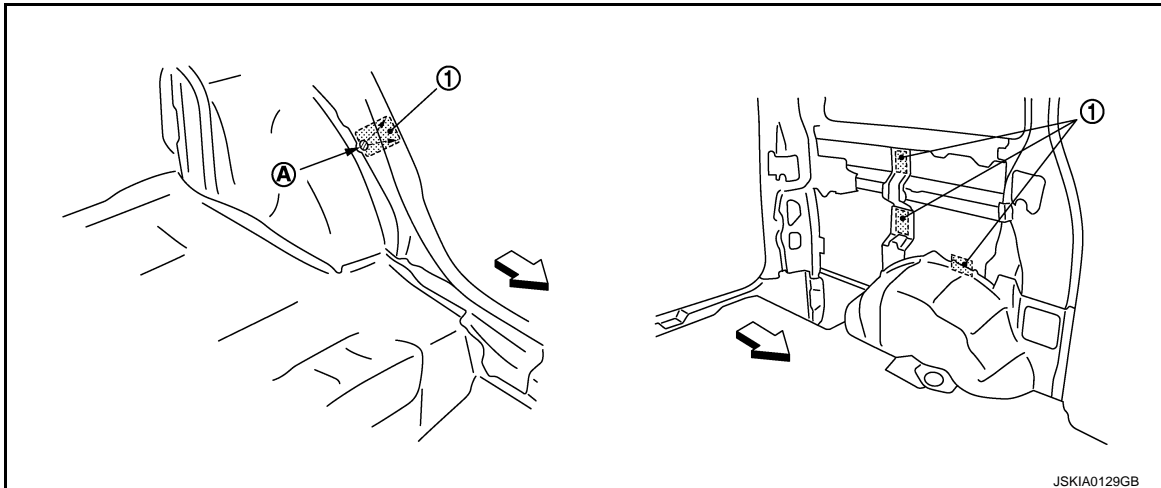

1. Urethane foam
  - A. Nozzle insert hole
- ↙: Vehicle front

2. Fill procedures before installation of service part.
  - a. Eliminate foam material remaining on vehicle side.
  - b. Clean area after eliminating foam insulator and foam material.
  - c. Fill foam material on wheelhouse outer side.

# REPAIRING MATERIAL

## < PREPARATION >

- 1. Urethane foam
- A. Fill while avoiding flange area

←: Vehicle front

**NOTE:**

Fill enough to close gap with service part while avoiding flange area.

- d. Install service part.

**NOTE:**

Refer to label for information on working times.

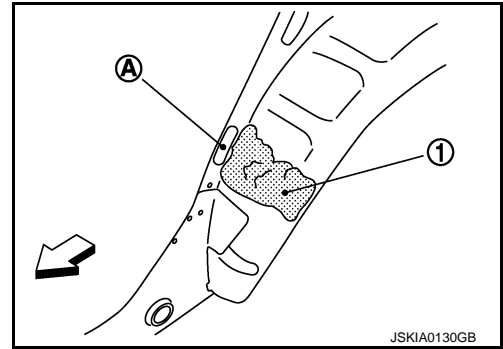

A  
B  
C  
D  
E  
F  
G  
H  
I  
J  
L  
M  
N  
O  
P

BRM

# BODY COMPONENT PARTS

< PREPARATION >

## BODY COMPONENT PARTS

### Underbody Component Parts (2WD Models)

INFOID:00000009750249

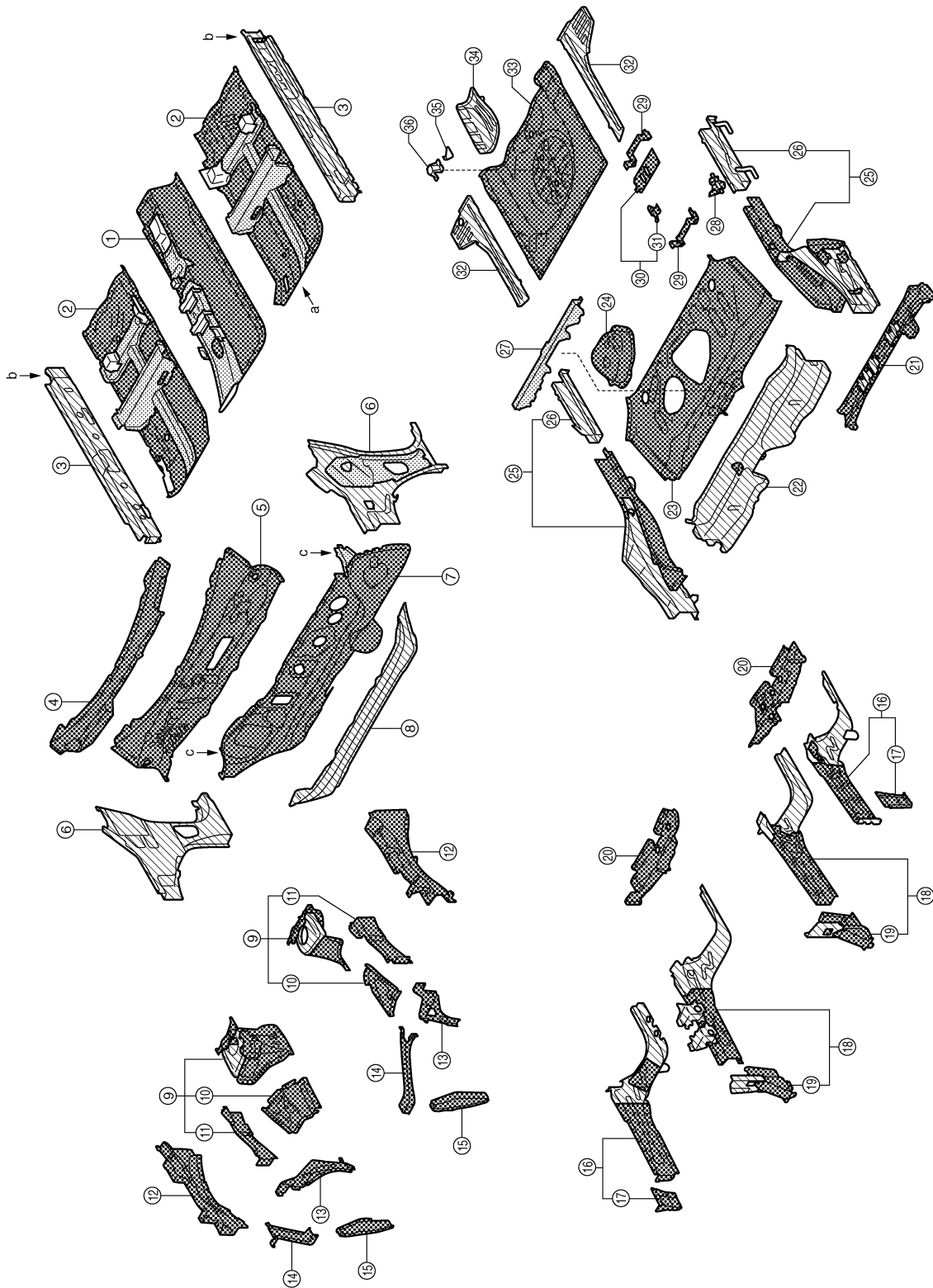

JSKIA2193ZZ

- Both sided anti-corrosive pre-coated steel sections
- High strength steel (HSS) sections
- Both sided anti-corrosive steel and HSS sections



# BODY COMPONENT PARTS

## < PREPARATION >

No.	Parts name		Tensile strength (MPa)	Both sided anti-corrosive precoated steel sections		
1.	Center front floor		590	×	A	
2.	Front floor (RH & LH)	a.	T=1.8 mm (0.071 in)	980 <sup>caution</sup>	×	B
3.	Inner sill (RH & LH)	b.	T=1.4 mm (0.055 in)	980 <sup>caution</sup>	×	C
4.	Inner cowl top		Under 440	×		
5.	Upper dash		Under 440	×		
6.	Side dash (RH & LH)		590	×	D	
7.	Lower dash	c.	T=1.4 mm (0.055 in)	980 <sup>caution</sup>	×	E
8.	Lower dash crossmember		780	×		
9.	Front strut housing (RH & LH)		590	×		
10.	Lower front hoodledge (RH & LH)		Under 440	×	F	
11.	Upper hoodledge (RH & LH)		Under 440	×		
12.	Hoodledge reinforcement (RH & LH)		Under 440	×		
13.	Hoodledge connector (RH & LH)		Under 440	×	G	
14.	Side radiator core support (RH & LH Upper)		Under 440	×		
15.	Side radiator core support (RH & LH Lower)		Under 440	×	H	
16.	Front side member closing plate assembly (RH & LH)		590	×		
17.	Add on frame bracket (RH & LH)		Under 440	×	I	
18.	Front side member assembly (RH & LH)		590	×		
19.	Front suspension mounting bracket (RH & LH Front)		440	×		
20.	Front suspension mounting bracket (RH & LH Rear)		Under 440	×	J	
21.	Rear crossmember center assembly		780	×		
22.	Rear seat crossmember		440	×		
23.	Rear floor front		Under 440	×	BRM	
24.	Rear floor rear cover		Under 440	×		
25.	Rear side member (RH & LH)		780	×	L	
26.	Rear side member extension (RH & LH)		440	×		
27.	Upper rear seat crossmember		440	—		
28.	Muffler mounting bracket		Under 440	×	M	
29.	Canister mounting bracket		Under 440	×		
30.	Spare wheel clamp reinforcement		Under 440	×		
31.	Canister bracket (Front)		Under 440	×	N	
32.	Rear floor rear side (RH & LH)		440	×		
33.	Rear floor rear		Under 440	×	O	
34.	Rear towing hook bracket		440	×		
35.	Canister bracket (Rear)		Under 440	—	P	
36.	Spare tire clamp bracket		Under 440	—		

### NOTE:

- For the parts without a number described in the figure, it is supplied only with the assembly part that the part is included with.
- Tensile strength column shows the largest strength value of a part in the component part.

### CAUTION:

If the high strength steel (ultra high strength steel) of this is broken, replace by assembly for the supply part.

# BODY COMPONENT PARTS

< PREPARATION >

## Underbody Component Parts (AWD Models)

INFOID:00000009750250

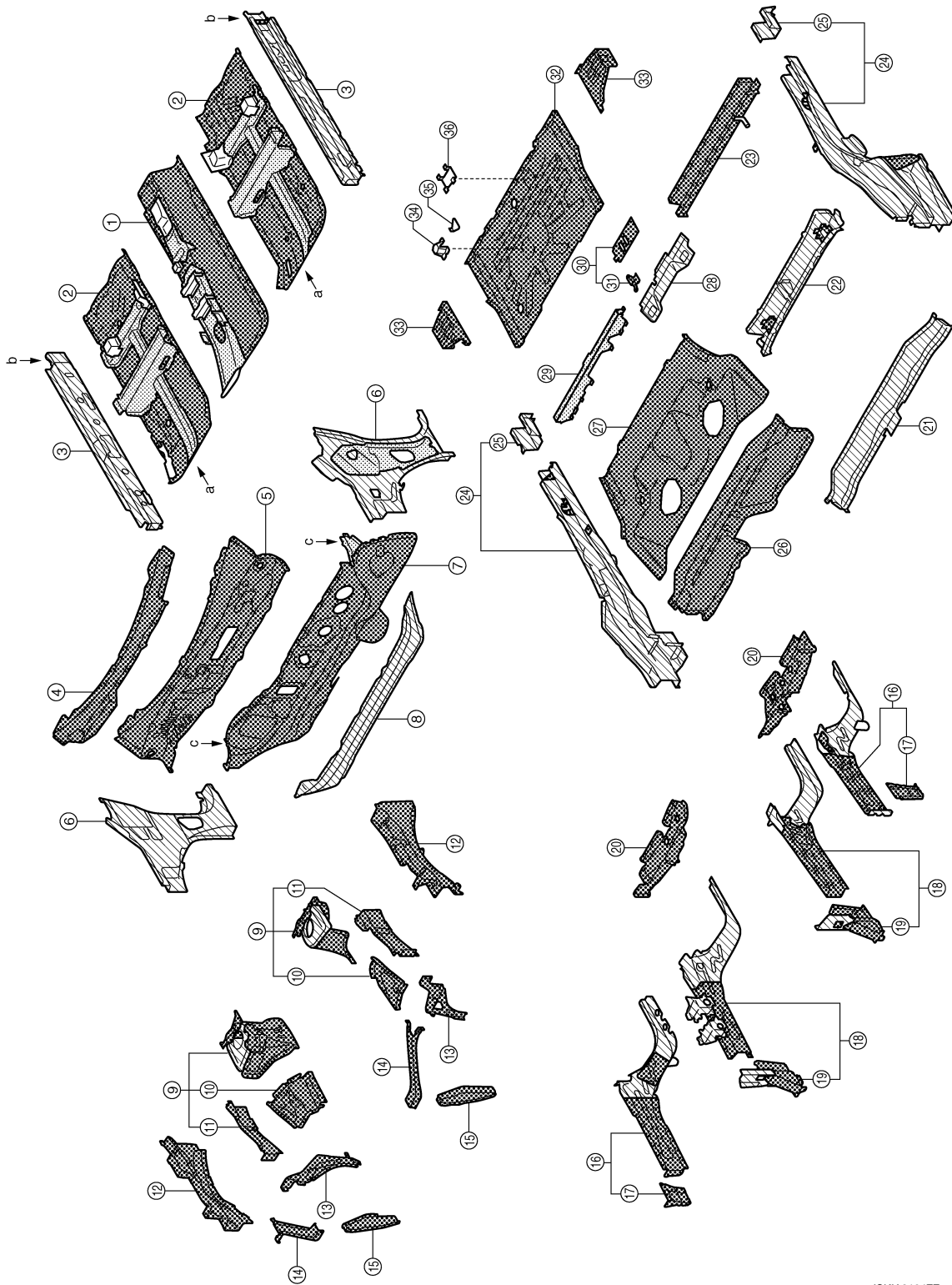

JSKIA2194ZZ

- Both sided anti-corrosive pre-coated steel sections
- High strength steel (HSS) sections
- Both sided anti-corrosive steel and HSS sections

# BODY COMPONENT PARTS

## < PREPARATION >

No.	Parts name		Tensile strength (MPa)	Both sided anti-corrosive precoated steel sections	
1.	Center front floor		590	×	A
2.	Front floor (RH & LH)	a. T=1.8 mm (0.071 in)	980 <sup>caution</sup>	×	B
3.	Inner sill (RH & LH)	b. T=1.4 mm (0.055 in)	980 <sup>caution</sup>	×	C
4.	Inner cowl top		Under 440	×	
5.	Upper dash		Under 440	×	
6.	Side dash (RH & LH)		590	×	D
7.	Lower dash	c. T=1.4 mm (0.055 in)	980 <sup>caution</sup>	×	E
8.	Lower dash crossmember		780	×	
9.	Front strut housing (RH & LH)		590	×	
10.	Lower front hoodledge (RH & LH)		Under 440	×	F
11.	Upper hoodledge (RH & LH)		Under 440	×	
12.	Hoodledge reinforcement (RH & LH)		Under 440	×	
13.	Hoodledge connector (RH & LH)		Under 440	×	G
14.	Side radiator core support (RH & LH Upper)		Under 440	×	
15.	Side radiator core support (RH & LH Lower)		Under 440	×	H
16.	Front side member closing plate assembly (RH & LH)		590	×	
17.	Add on frame bracket (RH & LH)		Under 440	×	I
18.	Front side member assembly (RH & LH)		590	×	
19.	Front suspension mounting bracket (RH & LH Front)		440	×	
20.	Front suspension mounting bracket (RH & LH Rear)		Under 440	×	J
21.	Rear seat crossmember		440	×	
22.	Rear crossmember center assembly		590	×	
23.	7th crossmember		Under 440	×	BRM
24.	Rear side member (RH & LH)		780	×	
25.	Rear side member extension (RH & LH)		590	×	L
26.	Rear floor front extension		Under 440	×	
27.	Rear floor front		Under 440	×	
28.	Rear floor belt anchor reinforcement		590	×	M
29.	Upper rear seat crossmember		440	—	
30.	Spare wheel clamp reinforcement		Under 440	×	
31.	Canister bracket (Front)		Under 440	×	N
32.	Rear floor rear		Under 440	×	
33.	Rear floor rear side (RH & LH)		Under 440	×	O
34.	Spare tire clamp bracket		Under 440	—	
35.	Canister bracket (Rear)		Under 440	—	P
36.	Jack mounting bracket		Under 440	—	

**NOTE:**

- For the parts without a number described in the figure, it is supplied only with the assembly part that the part is included with.
- Tensile strength column shows the largest strength value of a part in the component part.

**CAUTION:**

If the high strength steel (ultra high strength steel) of this is broken, replace by assembly for the supply part.

# BODY COMPONENT PARTS

< PREPARATION >

## Body Component Parts (2WD Models)

INFOID:00000009750251

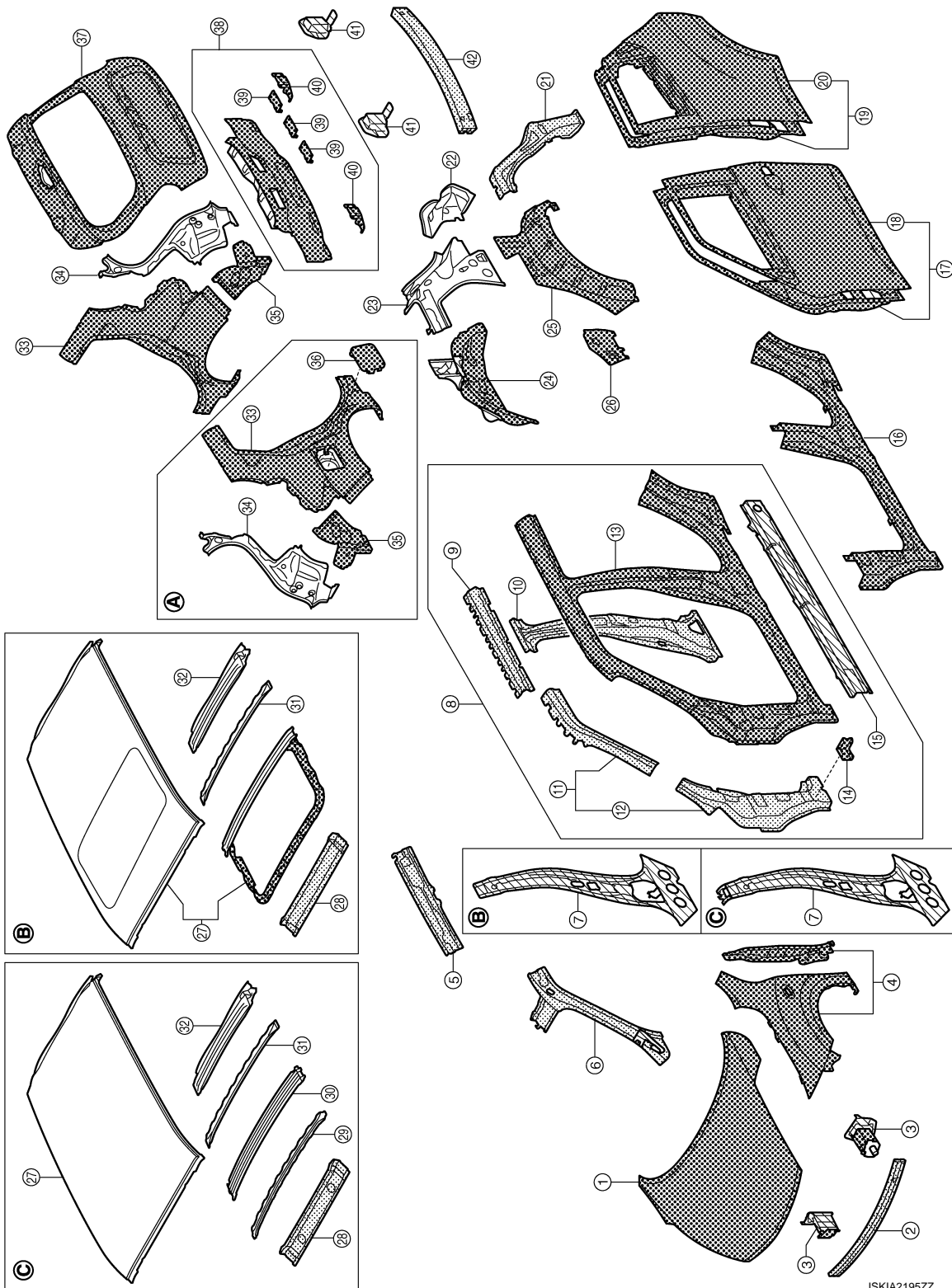

JSKIA2195ZZ

A. Right side

B. With sunroof models

C. Standard roof models

Both sided anti-corrosive pre-coated steel sections

High strength steel (HSS) sections

Both sided anti-corrosive steel and HSS sections

# BODY COMPONENT PARTS

## < PREPARATION >

No.	Parts name		Tensile strength (MPa)	Both sided anti-corrosive pre-coated steel sections	
1.	Hood		Under 440	×	A
2.	Inner center front bumper reinforcement	T=1.2 mm (0.047 in)	1310 <sup>caution</sup>	—	B
3.	Front side member front assembly (RH & LH)		590	×	
4.	Front fender (RH & LH)		Under 440	×	C
5.	Inner side roof rail (RH & LH)		590	—	
6.	Upper inner front pillar (RH & LH)		780	—	D
7.	Inner center pillar (RH & LH)		590	×	
8.	Side body assembly (RH & LH)		Refer to No.9-15		
	9.	Outer side roof rail reinforcement (RH & LH)	590	—	E
	10.	Lower center pillar brace (RH & LH)	590	—	
	11.	Front pillar brace (RH & LH)	590	—	F
	12.	Lower front pillar hinge brace (RH & LH)	590	—	
	13.	Outer front side body (RH & LH)	Under 440	×	G
	14.	Front fender bracket assembly (RH & LH)	Under 440	×	
	15.	Outer sill reinforcement (RH & LH)	780	×	H
16.	Outer sill (RH & LH)		Under 440	×	
17.	Front door (RH & LH)		Under 440	×	I
18.	Outer front door panel (RH & LH)		Under 440	×	
19.	Rear door (RH & LH)		Under 440	×	J
20.	Outer rear door panel (RH & LH)		Under 440	×	
21.	Inner rear pillar reinforcement (RH & LH)		440	—	BRM
22.	Rear pillar reinforcement (RH & LH)		Under 440	—	
23.	Inner rear pillar (RH & LH)		Under 440	—	
24.	Inner rear wheelhouse (RH & LH)		440	×	L
25.	Outer rear wheelhouse (RH & LH)		Under 440	×	
26.	Outer rear wheelhouse extension (RH & LH)		Under 440	×	M
27.	Roof		Under 440	—	
28.	Front roof rail		780	—	N
29.	Roof bow No.1		Under 440	—	
30.	Roof bow No.2		590	—	O
31.	Roof bow No.3		Under 440	—	
32.	Rear roof rail		Under 440	—	P
33.	Rear fender (RH & LH)		Under 440	×	
34.	Rear fender extension (RH & LH)		Under 440	—	
35.	Rear fender corner (RH & LH)		Under 440	×	
36.	Fuel filler lid		Under 440	×	
37.	Back door		Under 440	×	
38.	Upper rear panel		Under 440	×	
39.	Upper rear bumper retainer		Under 440	×	
40.	Rear side bumper bracket		Under 440	×	
41.	Rear bumper stay (RH & LH)		590	×	
42.	Inner center rear bumper reinforcement	T=1.2 mm (0.047 in)	1310 <sup>caution</sup>	—	

# BODY COMPONENT PARTS

## < PREPARATION >

### NOTE:

- For the parts without a number described in the figure, it is supplied only with the assembly part that the part is included with.
- Tensile strength column shows the largest strength value of a part in the component part.

### CAUTION:

If the high strength steel (ultra high strength steel) of this is broken, replace by assembly for the supply part.

## Body Component Parts (AWD Models)

INFOID:000000009750252

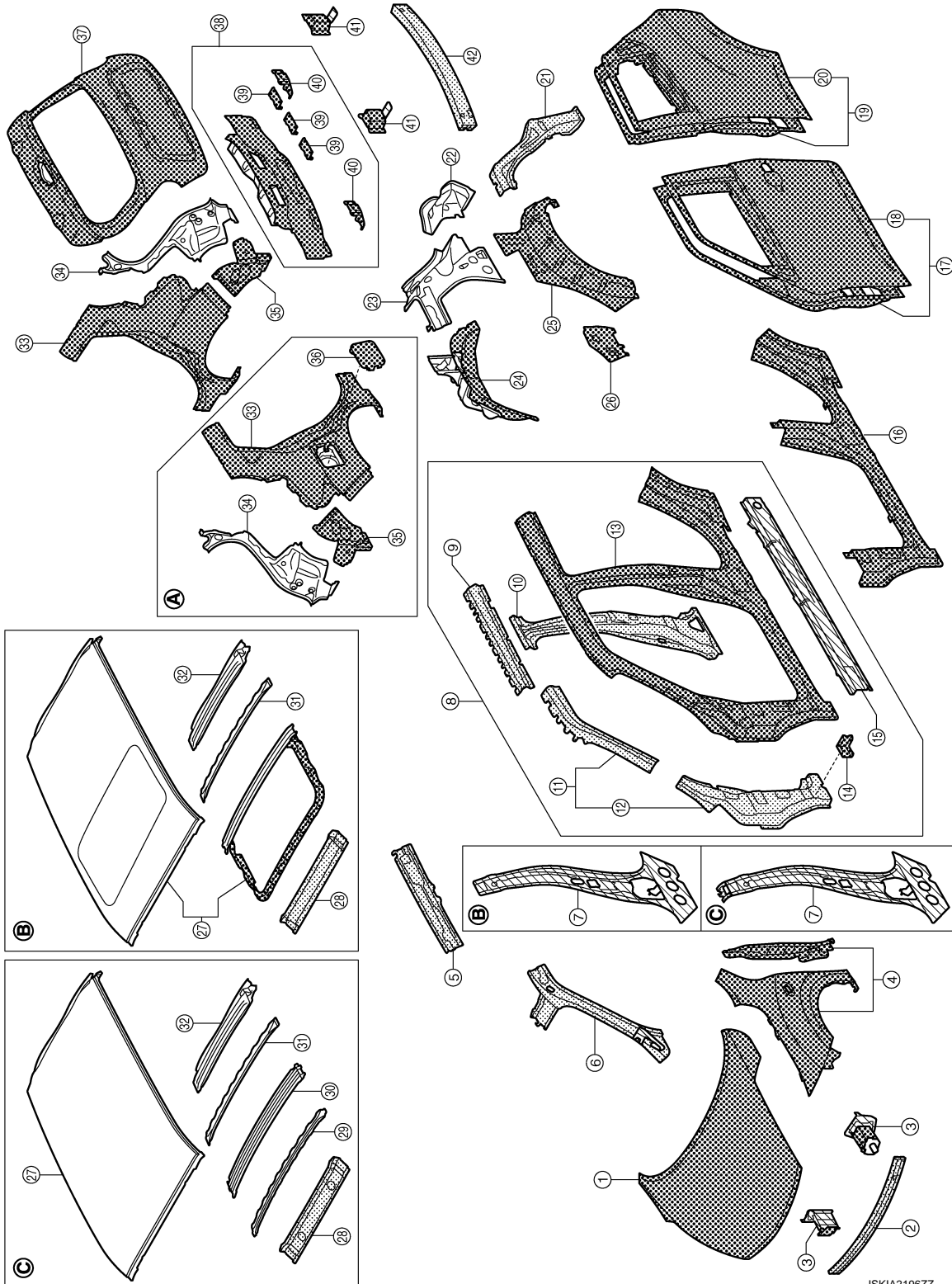

# BODY COMPONENT PARTS

## < PREPARATION >

A. Right side

B. With sunroof models

C. Standard roof models

 Both sided anti-corrosive precoated steel sections

 High strength steel (HSS) sections

 Both sided anti-corrosive steel and HSS sections

No.	Parts name	Tensile strength (MPa)	Both sided anti-corrosive precoated steel sections
1.	Hood	Under 440	×
2.	Inner center front bumper reinforcement	T=1.2 mm (0.047 in) 1310 <sup>caution</sup>	—
3.	Front side member front assembly (RH & LH)	590	×
4.	Front fender (RH & LH)	Under 440	×
5.	Inner side roof rail (RH & LH)	590	—
6.	Upper inner front pillar (RH & LH)	780	—
7.	Inner center pillar (RH & LH)	590	×
8.	Side body assembly (RH & LH)	Refer to No.9–15	
9.	Outer side roof rail reinforcement (RH & LH)	590	—
10.	Lower center pillar brace (RH & LH)	590	—
11.	Front pillar brace (RH & LH)	590	—
12.	Lower front pillar hinge brace (RH & LH)	590	—
13.	Outer front side body (RH & LH)	Under 440	×
14.	Front fender bracket assembly (RH & LH)	Under 440	×
15.	Outer sill reinforcement (RH & LH)	780	×
16.	Outer sill (RH & LH)	Under 440	×
17.	Front door (RH & LH)	Under 440	×
18.	Outer front door panel (RH & LH)	Under 440	×
19.	Rear door (RH & LH)	Under 440	×
20.	Outer rear door panel (RH & LH)	Under 440	×
21.	Inner rear pillar reinforcement (RH & LH)	440	—
22.	Rear pillar reinforcement (RH & LH)	Under 440	—
23.	Inner rear pillar (RH & LH)	Under 440	—
24.	Inner rear wheelhouse (RH & LH)	440	×
25.	Outer rear wheelhouse (RH & LH)	Under 440	×
26.	Outer rear wheelhouse extension (RH & LH)	Under 440	×
27.	Roof	Under 440	—
28.	Front roof rail	780	—
29.	Roof bow No.1	Under 440	—
30.	Roof bow No.2	590	—
31.	Roof bow No.3	Under 440	—
32.	Rear roof rail	Under 440	—
33.	Rear fender (RH & LH)	Under 440	×
34.	Rear fender extension (RH & LH)	Under 440	—
35.	Rear fender corner (RH & LH)	Under 440	×
36.	Fuel filler lid	Under 440	×
37.	Back door	Under 440	×
38.	Upper rear panel	Under 440	×

## BODY COMPONENT PARTS

### < PREPARATION >

No.	Parts name	Tensile strength (MPa)	Both sided anti-corrosive precoated steel sections
39.	Upper rear bumper retainer	Under 440	×
40.	Rear side bumper bracket	Under 440	×
41.	Rear bumper stay (RH & LH)	440	×
42.	Inner center rear bumper reinforcement	T=1.2 mm (0.047 in) 1310 <sup>caution</sup>	—

#### NOTE:

- For the parts without a number described in the figure, it is supplied only with the assembly part that the part is included with.
- Tensile strength column shows the largest strength value of a part in the component part.

#### CAUTION:

If the high strength steel (ultra high strength steel) of this is broken, replace by assembly for the supply part.



# CORROSION PROTECTION

< REMOVAL AND INSTALLATION >

## REMOVAL AND INSTALLATION

### CORROSION PROTECTION

#### Description

INFOID:000000009750253

To provide improved corrosion prevention, the following anti-corrosive measures have been implemented in NISSAN production plants. When repairing or replacing body panels, it is necessary to use the same anti-corrosive measures.

#### ANTI-CORROSIVE PRECOATED STEEL (GALVANNEALED STEEL)

To improve repairability and corrosion resistance, a new type of anti-corrosive precoated steel sheet has been adopted replacing conventional zinc-coated steel sheet.

Galvannealed steel is electroplated and heated to form Zinc-iron alloy, which provides excellent and long term corrosion resistance with cationic electrodeposition primer.

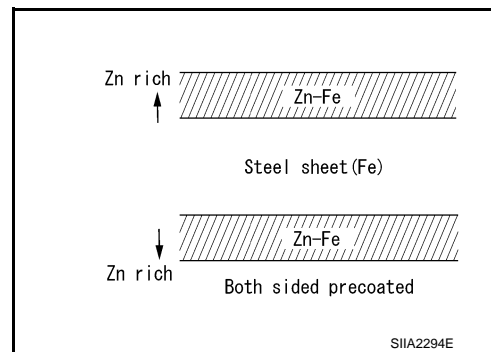

Nissan Genuine Service Parts are fabricated from galvannealed steel. Therefore, it is recommended that GENUINE NISSAN PARTS or equivalent be used for panel replacement to maintain the anti-corrosive performance built into the vehicle at the factory.

#### PHOSPHATE COATING TREATMENT AND CATIONIC ELECTRODEPOSITION PRIMER

A phosphate coating treatment and a cationic electrodeposition primer, which provide excellent corrosion protection, are employed on all body components.

#### **CAUTION:**

**Confine paint removal during welding operations to an absolute minimum.**

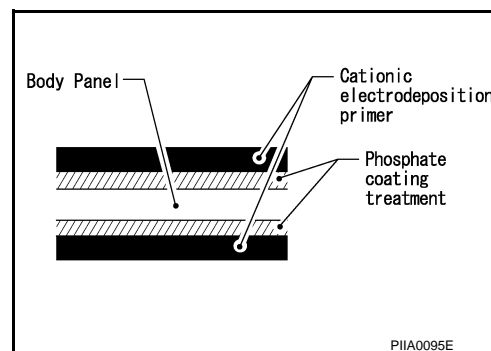

Nissan Genuine Service Parts are also treated in the same manner. Therefore, it is recommended that GENUINE NISSAN PARTS or an equivalent be used for panel replacement to maintain anti-corrosive performance built into the vehicle at the factory.

#### Anti-corrosive Wax

INFOID:000000009750254

To improve corrosion resistance, anti-corrosive wax is applied inside the body sill and inside other closed sections. Accordingly, when replacing these parts, be sure to apply anti-corrosive wax to the appropriate areas of the new parts. Select an excellent anti-corrosive wax which will penetrate after application and has a long shelf life.

#### DOOR

# CORROSION PROTECTION

## < REMOVAL AND INSTALLATION >

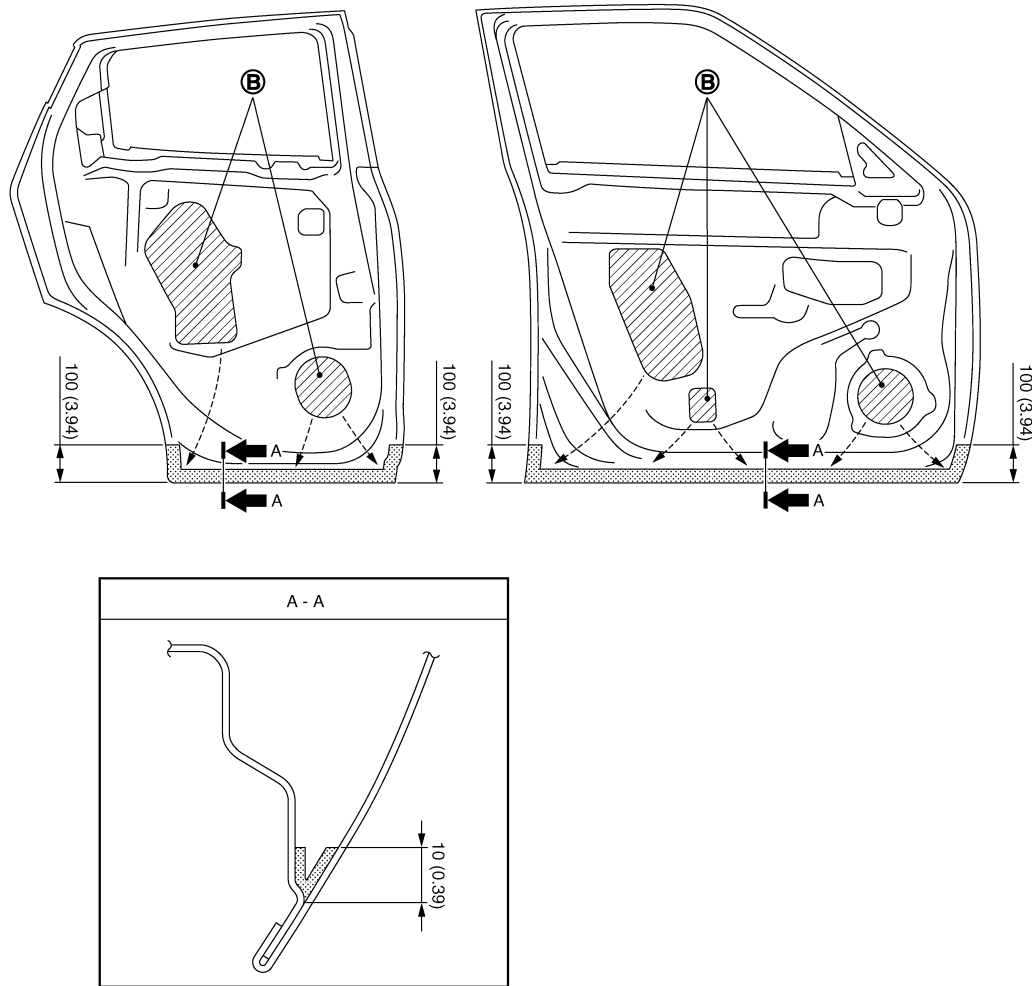

JSKIA2131ZZ

B. Nozzle insert hole

Unit: mm (in)

 Anti-corrosive wax coated portions

### Undercoating (2WD Models)

INFOID:000000009750255

The underside of the floor and wheelhouse are undercoated to prevent rust, vibration, noise and stone chipping. Therefore, when such a panel is replaced or repaired, apply undercoating to that part. Use an undercoating which is rust resistant, soundproof, vibration-proof, shock-resistant, adhesive, and durable.

### PRECAUTIONS IN UNDERCOATING

1. Never apply undercoating to any place unless specified (such as the areas above the muffler and three-way catalyst that are subjected to heat).
2. Never undercoat the exhaust pipe or other parts that become hot.
3. Never undercoat rotating parts.
4. Apply bitumen wax after applying undercoating.
5. After putting seal on the vehicle, put undercoating on it.

# CORROSION PROTECTION

## < REMOVAL AND INSTALLATION >

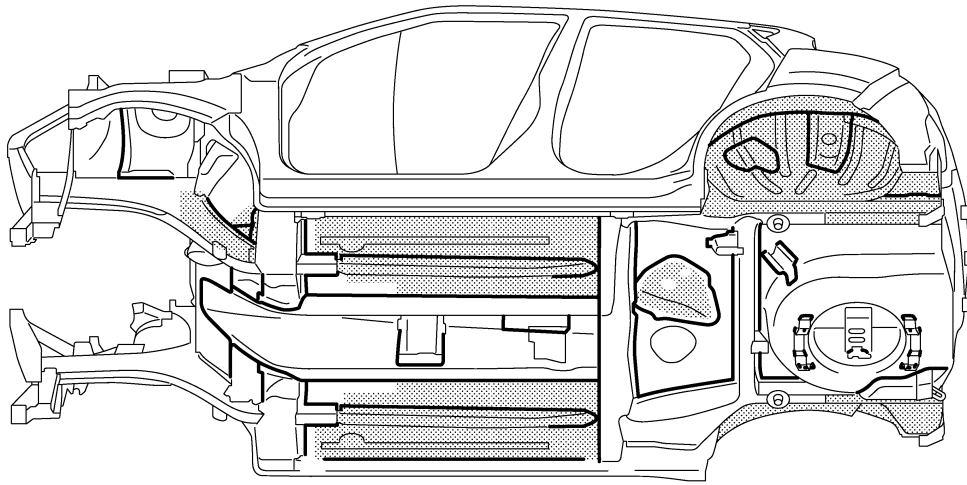

JSKIA2197ZZ

 Undercoated areas

 Sealed portions

### Undercoating (AWD Models)

INFOID:000000009750256

The underside of the floor and wheelhouse are undercoated to prevent rust, vibration, noise and stone chipping. Therefore, when such a panel is replaced or repaired, apply undercoating to that part. Use an undercoating which is rust resistant, soundproof, vibration-proof, shock-resistant, adhesive, and durable.

#### PRECAUTIONS IN UNDERCOATING

1. Never apply undercoating to any place unless specified (such as the areas above the muffler and three-way catalyst that are subjected to heat).
2. Never undercoat the exhaust pipe or other parts that become hot.
3. Never undercoat rotating parts.
4. Apply bitumen wax after applying undercoating.
5. After putting seal on the vehicle, put undercoating on it.

A  
B  
C  
D  
E  
F  
G  
H  
I  
J  
L  
M  
N  
O  
P

BRM

# CORROSION PROTECTION

## < REMOVAL AND INSTALLATION >

---

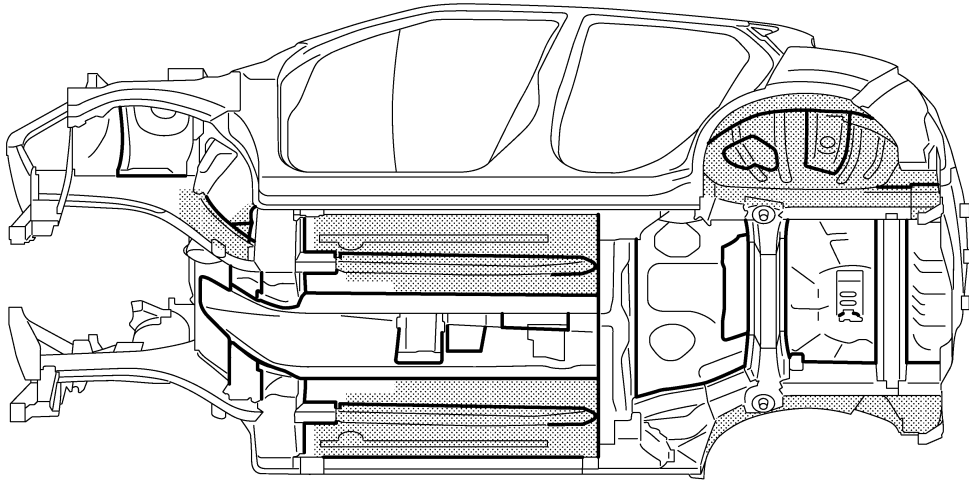

JSKIA2198ZZ

 Undercoated areas

 Sealed portions

### Body Sealing (2WD Models)

INFOID:000000009750257

The following figure shows the areas that are sealed at the factory. Sealant that is applied to these areas should be smooth and free from cuts or gaps. Care should be taken not to apply an excess amount of sealant and not to allow other unaffected parts to come into contact with the sealant.

# CORROSION PROTECTION

## < REMOVAL AND INSTALLATION >

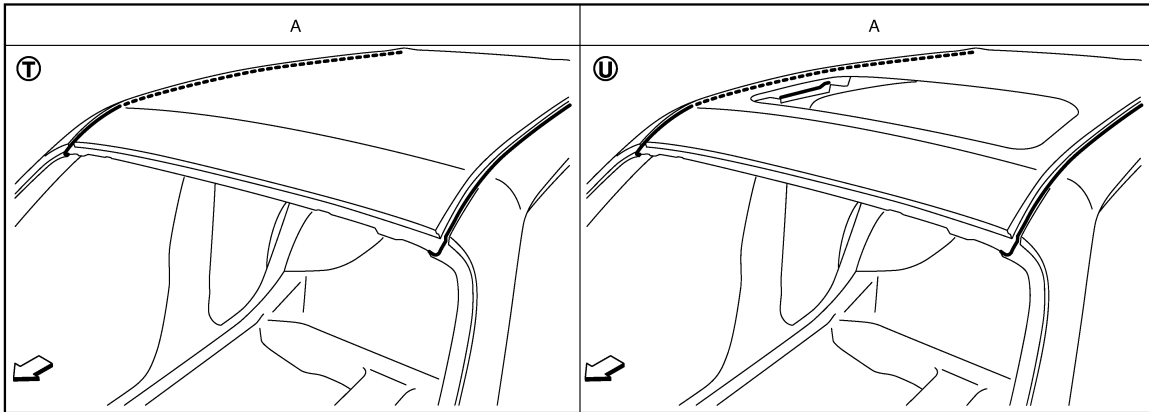
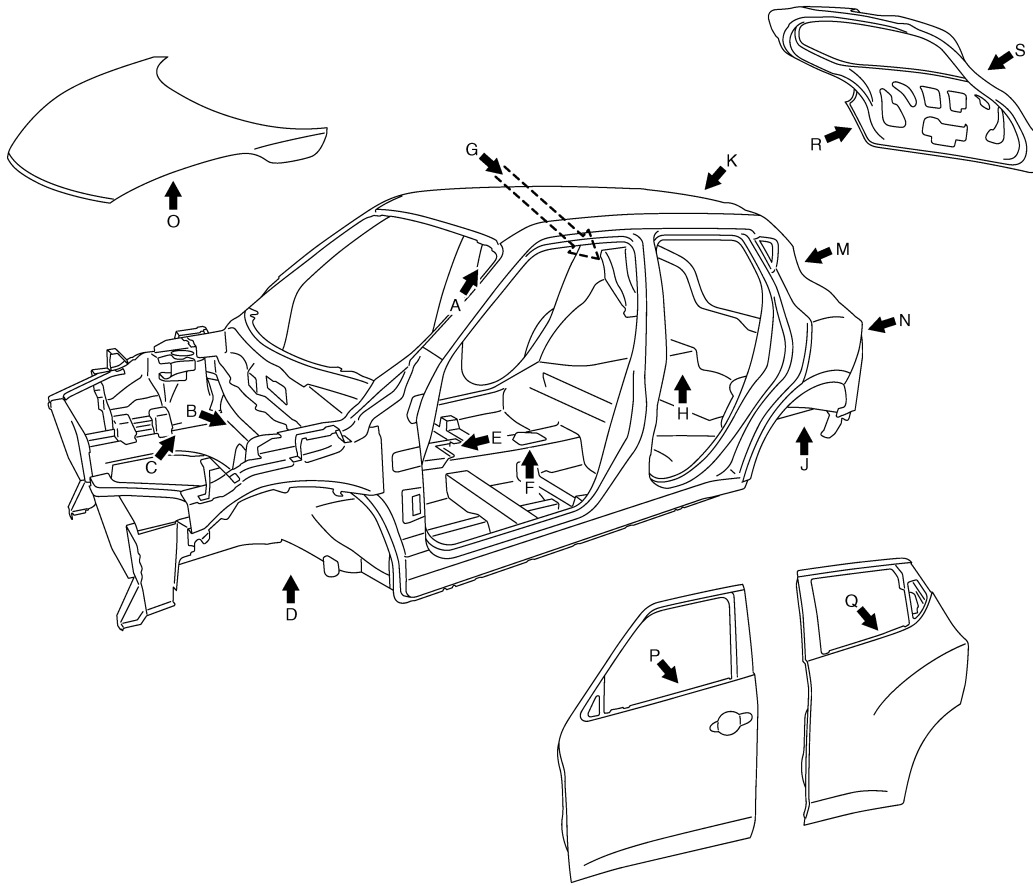

JSKIA2199ZZ

Ⓣ Standard roof models

Ⓤ With sunroof models

↔: Vehicle front

—: Sealed portions

A  
B  
C  
D  
E  
F  
G  
H  
I  
J  
L  
M  
N  
O  
P

BRM

# CORROSION PROTECTION

## < REMOVAL AND INSTALLATION >

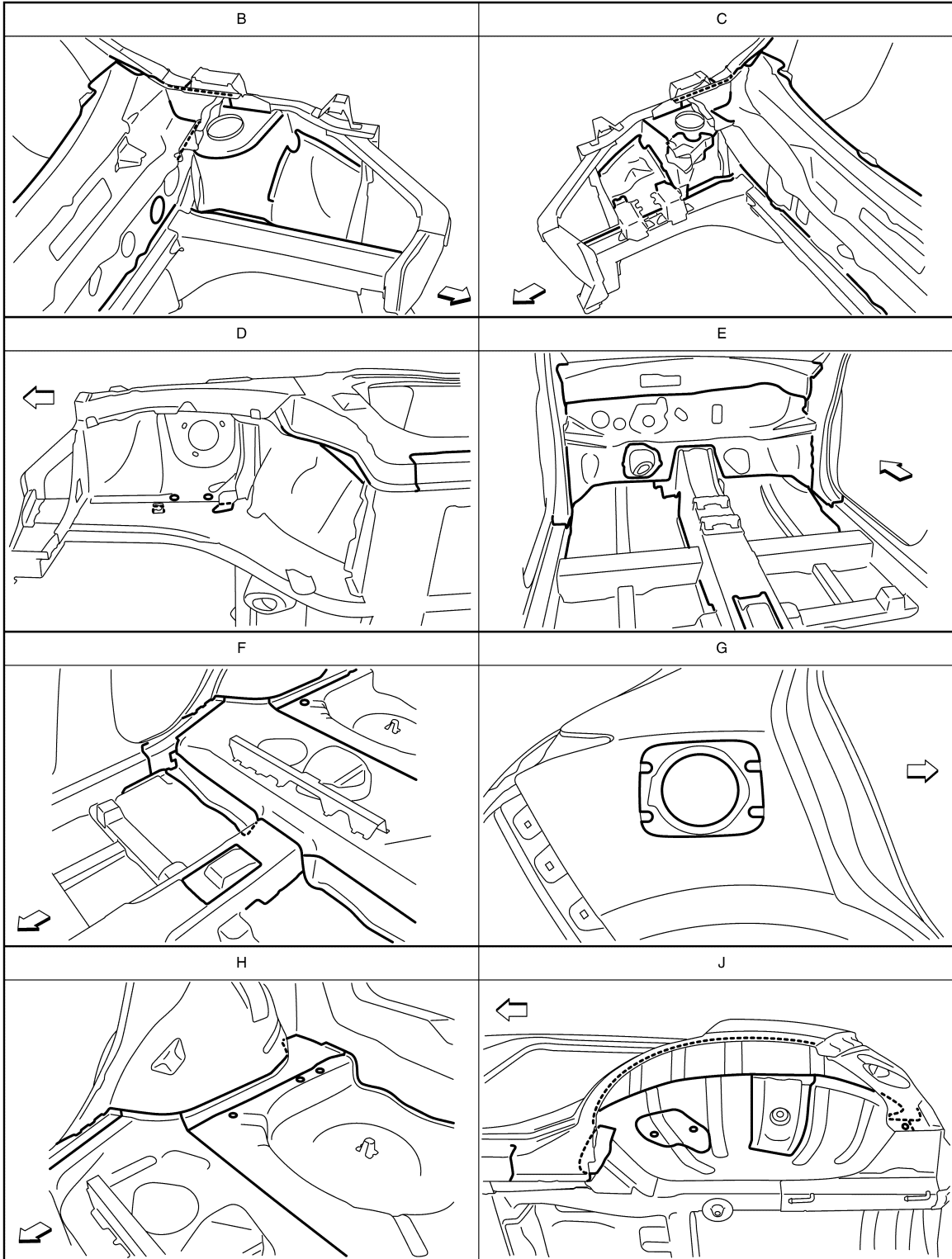

JSKIA3876ZZ

↙: Vehicle front  
—: Sealed portions

# CORROSION PROTECTION

## < REMOVAL AND INSTALLATION >

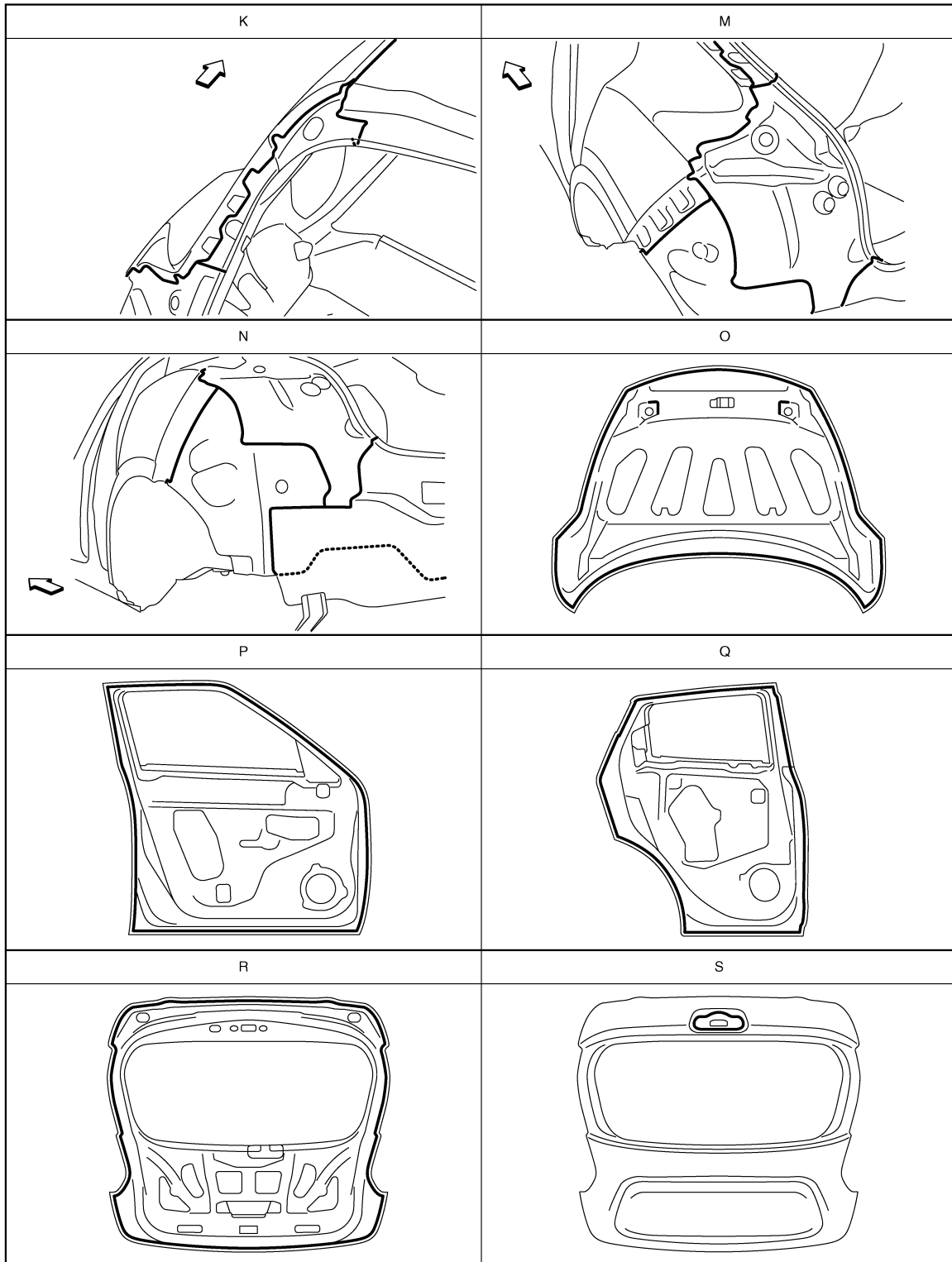

JSKIA2135ZZ

↔: Vehicle front  
 —: Sealed portions

A  
B  
C  
D  
E  
F  
G  
H  
I  
J  
K  
L  
M  
N  
O  
P

BRM

# CORROSION PROTECTION

< REMOVAL AND INSTALLATION >

## Body Sealing (AWD Models)

INFOID:00000009750258

The following figure shows the areas that are sealed at the factory. Sealant that is applied to these areas should be smooth and free from cuts or gaps. Care should be taken not to apply an excess amount of sealant and not to allow other unaffected parts to come into contact with the sealant.

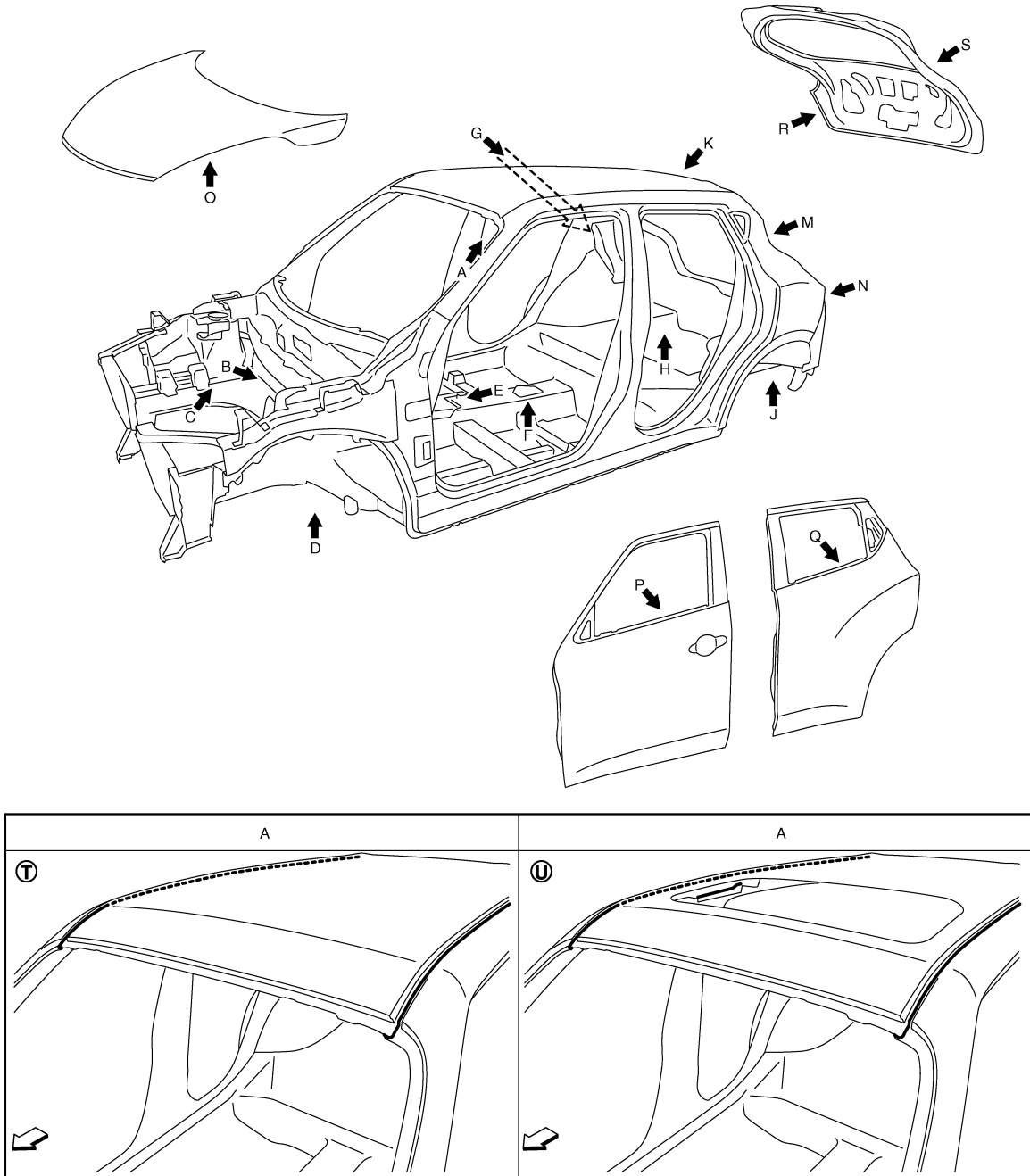

JSKIA2199ZZ

- Ⓙ Standard roof models
- Ⓚ With sunroof models
- ↶ Vehicle front
- ▬ Sealed portions



# CORROSION PROTECTION

## < REMOVAL AND INSTALLATION >

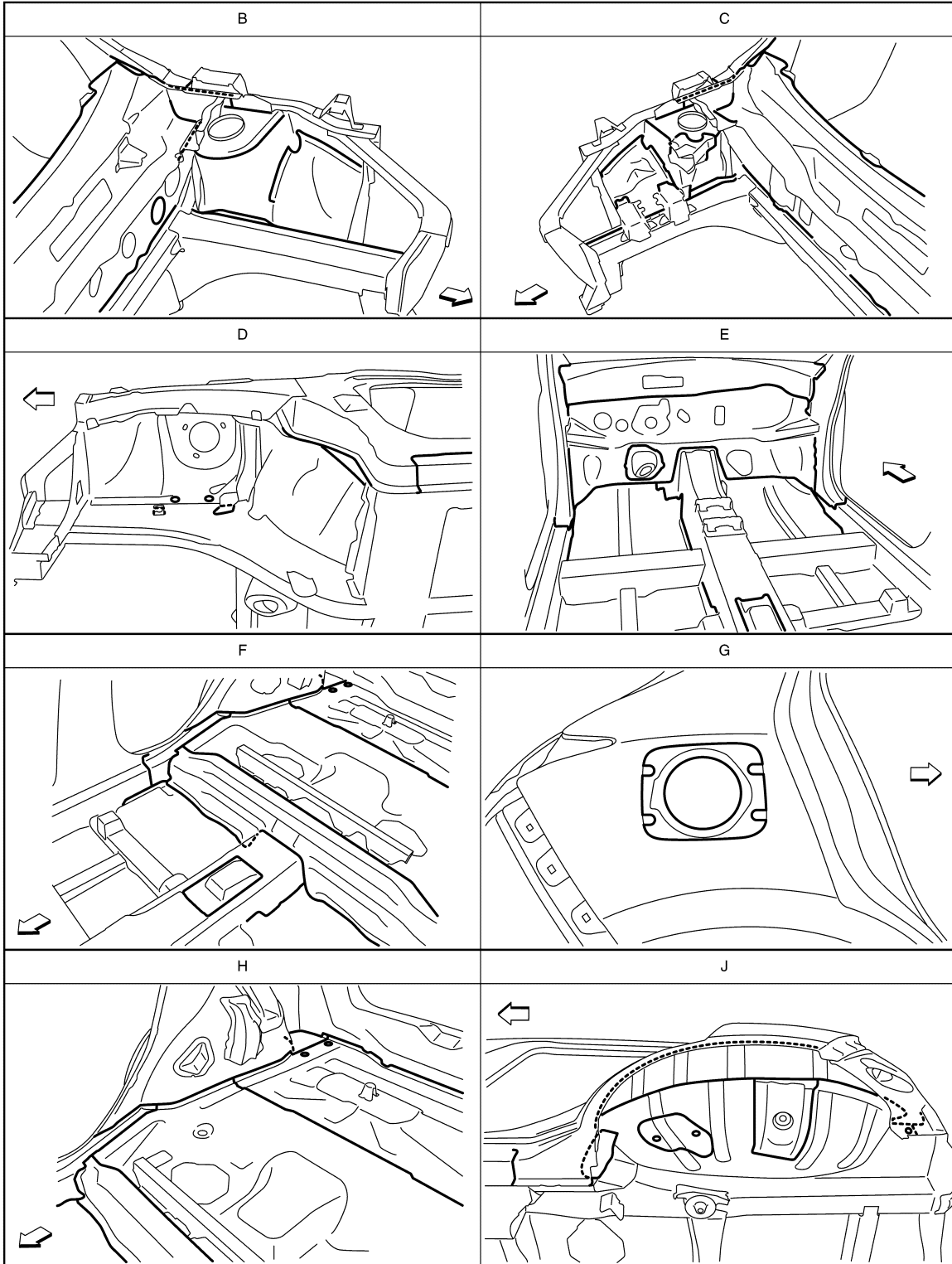

JSKIA3877ZZ

: Vehicle front  
 : Sealed portions

A  
 B  
 C  
 D  
 E  
 F  
 G  
 H  
 I  
 J  
 L  
 M  
 N  
 O  
 P

**BRM**

# CORROSION PROTECTION

## < REMOVAL AND INSTALLATION >

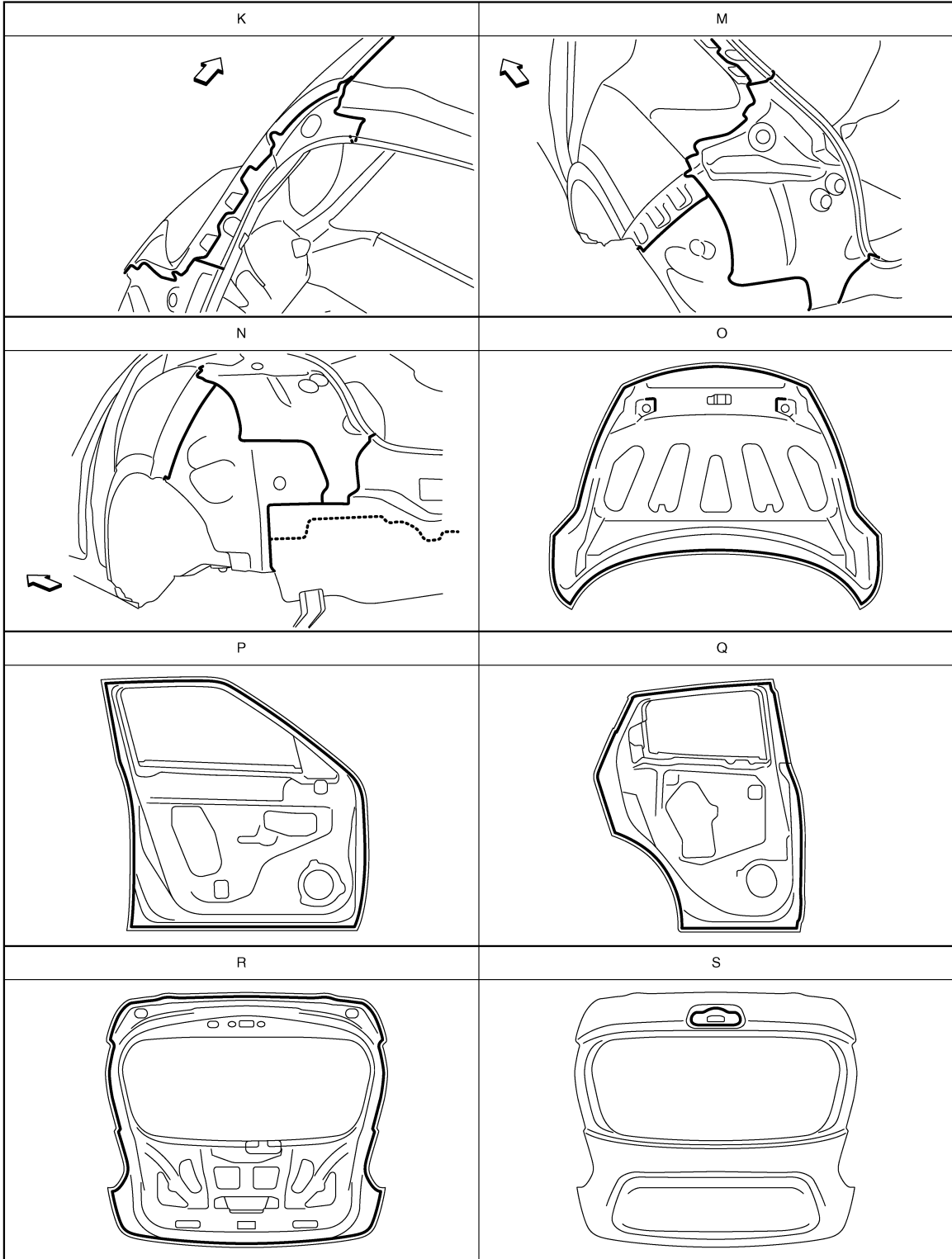

JSKIA2202ZZ

↶: Vehicle front  
—: Sealed portions

# BODY CONSTRUCTION

< REMOVAL AND INSTALLATION >

## BODY CONSTRUCTION

### Body Construction (Standard roof Models)

INFOID:000000009750259

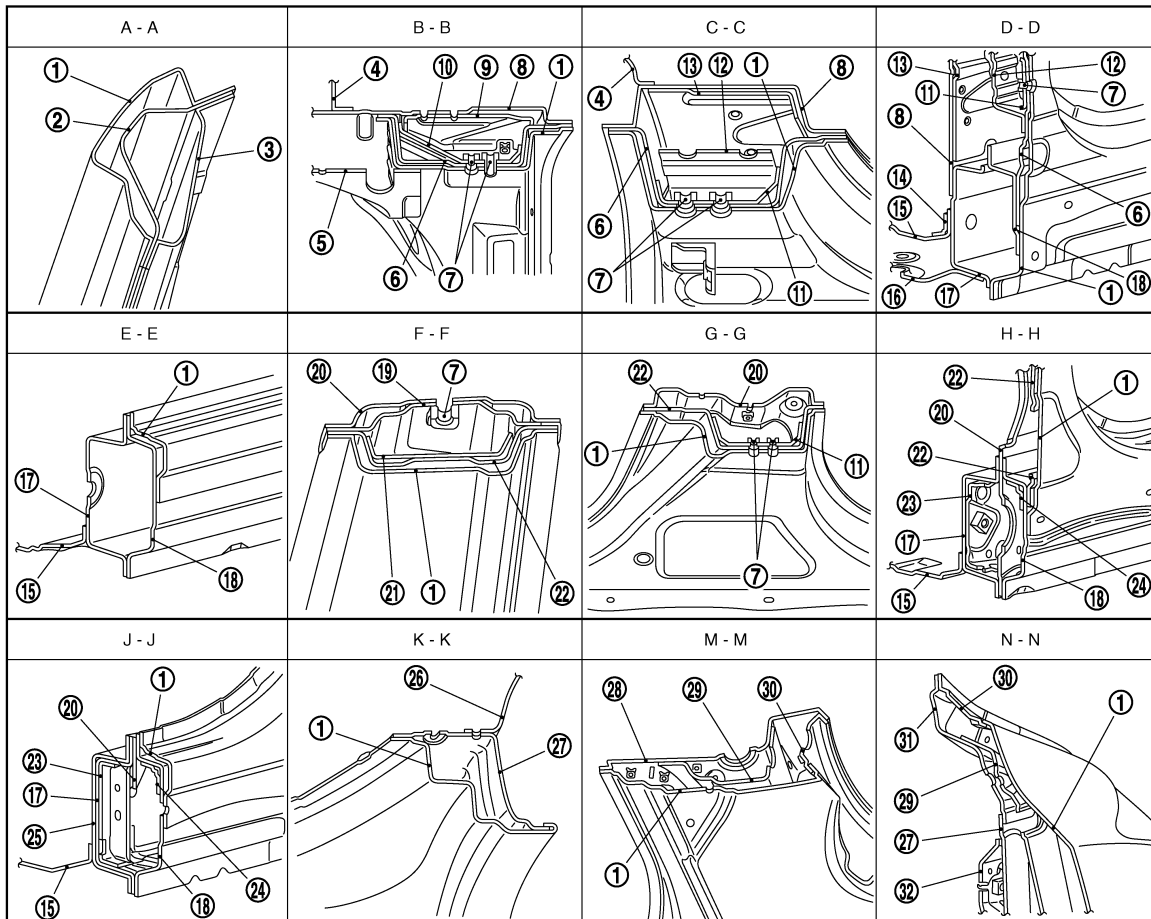
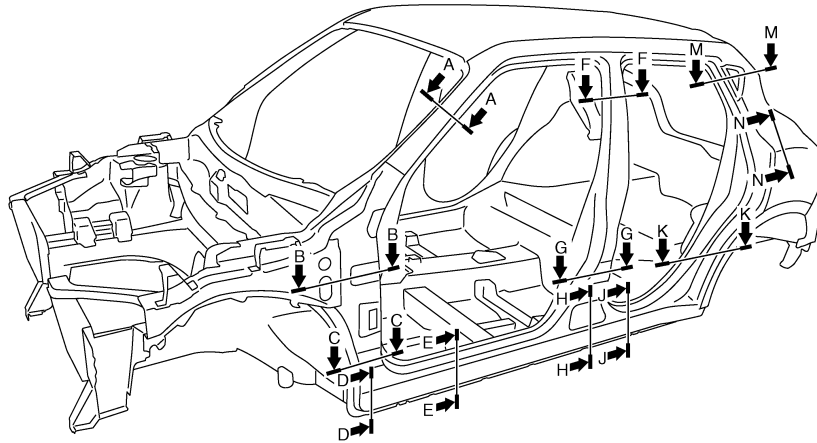

- |                    |                                     |                                     |
|--------------------|-------------------------------------|-------------------------------------|
| 1. Outer side body | 2. Outer front pillar reinforcement | 3. Upper inner front pillar         |
| 4. Lower dash      | 5. Hoodledge reinforcement          | 6. Lower front pillar hinge brace   |
| 7. Weld nut        | 8. Side dash                        | 9. Inner front pillar reinforcement |

JSKIA2203ZZ

A  
B  
C  
D  
E  
F  
G  
H  
I  
J  
K  
L  
M  
N  
O  
P

BRM

## BODY CONSTRUCTION

### < REMOVAL AND INSTALLATION >

---

- |                                       |   |                                 |
|---------------------------------------|---|---------------------------------|
| 10. Upper hinge plate                 | 11. Lower hinge plate                   | 12. Lower front pillar bulkhead |
| 13. Inner front pillar reinforcement  | 14. Front floor reinforcement           | 15. Front floor                 |
| 16. Front outrigger                   | 17. Inner sill                          | 18. Outer sill reinforcement    |
| 19. Inner center pillar reinforcement | 20. Inner center pillar                 | 21. Center pillar reinforcement |
| 22. Center pillar hinge brace         | 23. Inner sill reinforcement            | 24. Center sill reinforcement   |
| 25. Inner sill extension              | 26. Inner rear wheelhouse               | 27. Outer rear wheelhouse       |
| 28. Rear roof rail brace              | 29. Inner rear pillar reinforcement     | 30. Rear fender extension       |
| 31. Inner rear pillar                 | 32. Inner rear wheelhouse reinforcement |                                 |

# BODY CONSTRUCTION

< REMOVAL AND INSTALLATION >

## Body Construction (With sunroof Models)

INFOID:000000009750260

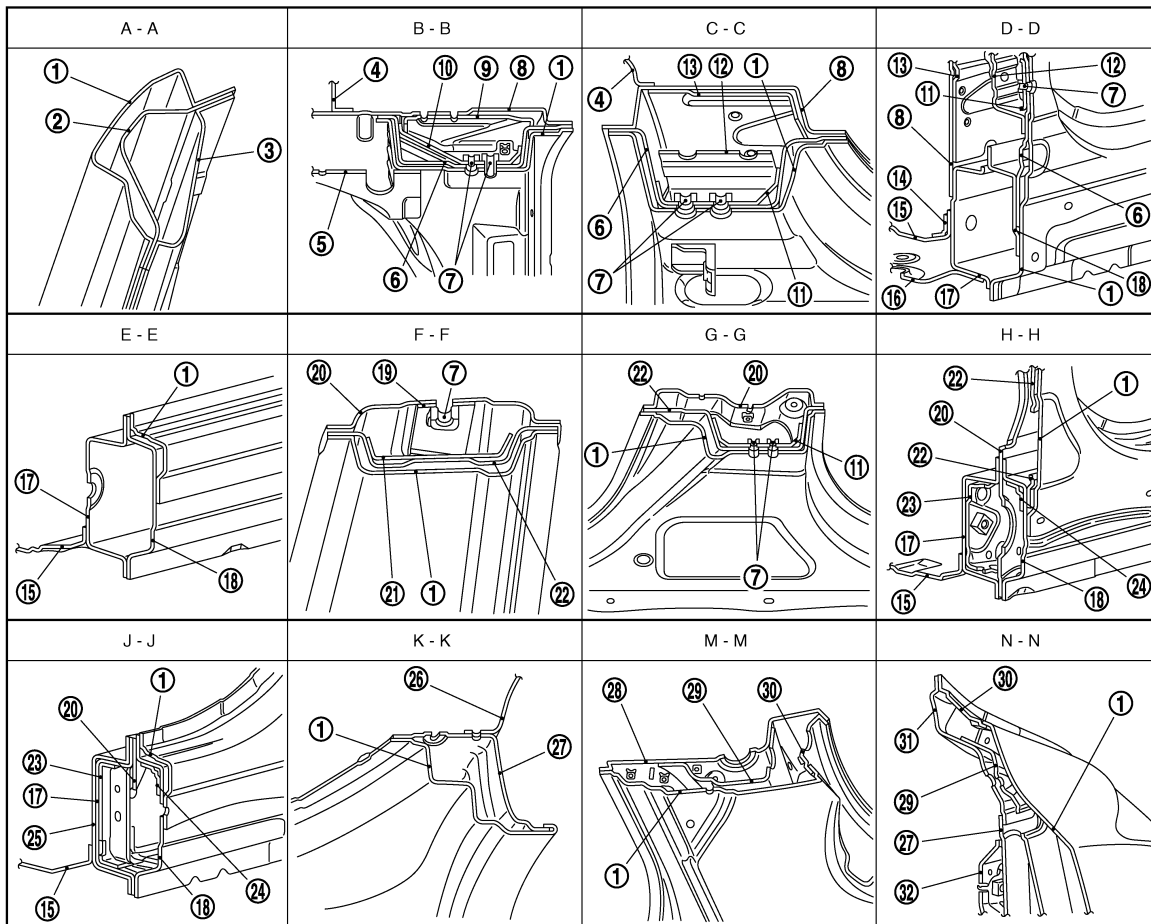
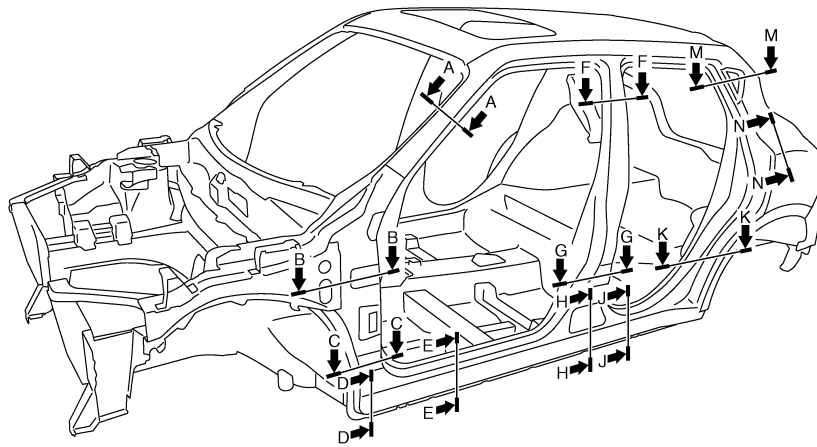

- |                                      |                                     |                                     |
|--------------------------------------|-------------------------------------|-------------------------------------|
| 1. Outer side body                   | 2. Outer front pillar reinforcement | 3. Upper inner front pillar         |
| 4. Lower dash                        | 5. Hoodledge reinforcement          | 6. Lower front pillar hinge brace   |
| 7. Weld nut                          | 8. Side dash                        | 9. Inner front pillar reinforcement |
| 10. Upper hinge plate                | 11. Lower hinge plate               | 12. Lower front pillar bulkhead     |
| 13. Inner front pillar reinforcement | 14. Front floor reinforcement       | 15. Front floor                     |

JSKIA2204ZZ

A  
B  
C  
D  
E  
F  
G  
H  
I  
J  
K  
L  
M  
N  
O  
P

BRM

# BODY CONSTRUCTION

## < REMOVAL AND INSTALLATION >

- |                               |   |                                 |
|-------------------------------|---|---------------------------------|
| 16. Front outrigger           | 17. Inner sill                          | 18. Outer sill reinforcement    |
| 19. Nut plate                 | 20. Inner center pillar                 | 21. Center pillar reinforcement |
| 22. Center pillar hinge brace | 23. Inner sill reinforcement            | 24. Center sill reinforcement   |
| 25. Inner sill extension      | 26. Inner rear wheelhouse               | 27. Outer rear wheelhouse       |
| 28. Rear roof rail brace      | 29. Inner rear pillar reinforcement     | 30. Rear fender extension       |
| 31. Inner rear pillar         | 32. Inner rear wheelhouse reinforcement |                                 |

## Rear Fender Hemming Process

INFOID:000000009750261

1. A wheel arch is to be installed and hemmed over the left and right outer wheel houses.
2. In order to hem the wheel arch, it is necessary to repair any damaged or defaced parts around outer wheel house.

### CAUTION:

**Ensure that the area that is to be glued around the outer wheelhouse is undamaged or defaced.**

### PROCEDURE OF THE HEMMING PROCESS

- Peel off old bonding material on the surface of the outer wheelhouse and clean thoroughly.
- Peel off a primer coat in the specified area where new adhesive is to be applied on rear fender (the replacing part).
- Apply new adhesive to both specified areas of the outer wheelhouse and rear fender.

**<Adhesive> 3M™ Automix™ Panel Bonding Adhesive 08115 or equivalent**

- Attach rear fender to the body of the car, and weld the required part except the hemming part.

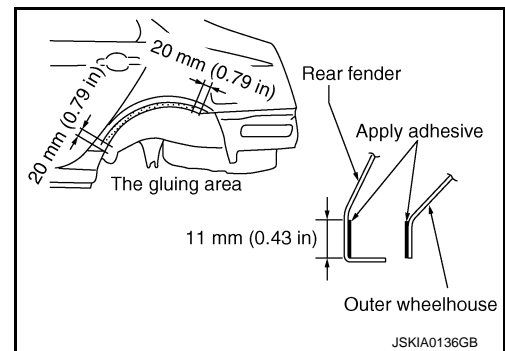

- Bend the welded part starting from the center of the wheel arch gradually with a hammer and a dolly. (Also hem the end of the flange.)
- Hemming with a hammer is conducted to an approximate angle of 80 degrees.

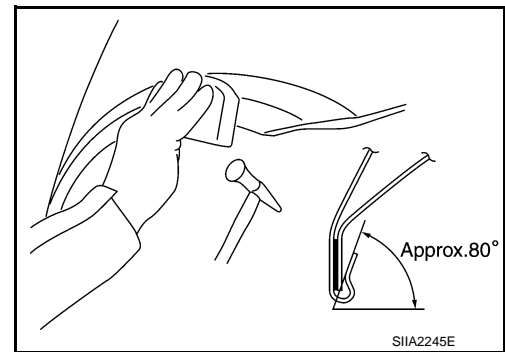

- Starting from the center, hem the wheel arch gradually, using slight back and forth motion with a hemming tool.

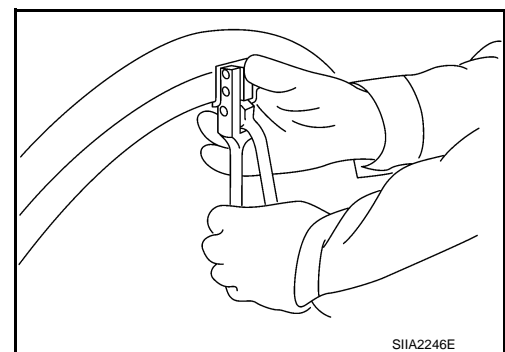

# BODY CONSTRUCTION

## < REMOVAL AND INSTALLATION >

- Seal up the area around the hemmed end of the flange.

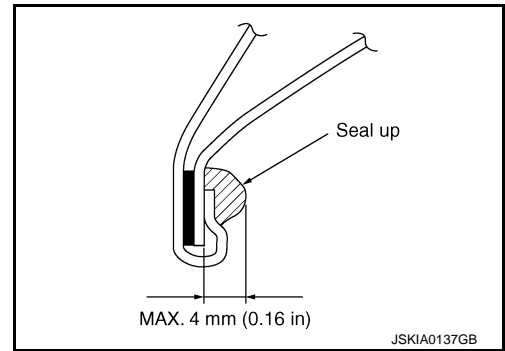

A  
B  
C  
D  
E  
F  
G  
H  
I  
J  
L  
M  
N  
O  
P

**BRM**

# REPLACEMENT OPERATIONS

< REMOVAL AND INSTALLATION >





## REPLACEMENT OPERATIONS

### Description

INFOID:00000009750262

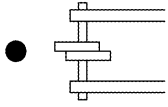
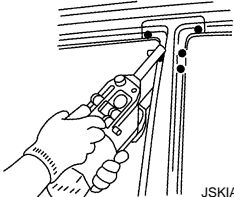
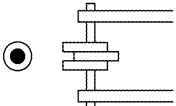
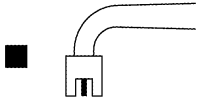
- This section is prepared for technicians who have attained a high level of skill and experience in repairing collision-damaged vehicles and also use modern service tools and equipment. Persons unfamiliar with body repair techniques should not attempt to repair collision-damaged vehicles by using this section.
- Technicians are also encouraged to read the Body Repair Manual (Fundamentals) in order to ensure that the original functions and quality of the vehicle are maintained. The Body Repair Manual (Fundamentals) contains additional information, including cautions and warnings, that are not including in this manual. Technicians should refer to both manuals to ensure proper repair.
- Please note that this information is prepared for worldwide usage, and as such, certain procedures might not apply in some regions or countries.

The symbols used in this section for welding operations are shown below.

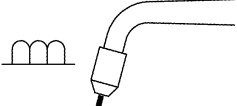
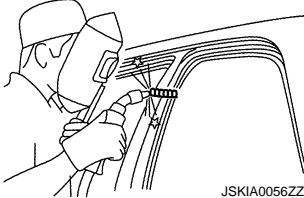
Symbol marks	Description	
 <p data-bbox="402 844 490 861">JSKIA0049ZZ</p>	2-spot welds	 <p data-bbox="1291 970 1377 987">JSKIA0053ZZ</p>
 <p data-bbox="402 1094 490 1110">JSKIA0050ZZ</p>	3-spot welds	
 <p data-bbox="402 1472 490 1488">JSKIA0051ZZ</p>	MIG plug weld	 <p data-bbox="1291 1348 1377 1365">JSKIA0054ZZ</p> <p data-bbox="1010 1381 1318 1407">For 3 panels plug weld method</p> <div style="display: flex; flex-direction: column; align-items: center;"> <div data-bbox="1144 1438 1307 1480"> <p data-bbox="1144 1449 1177 1470">■ A</p>  </div> <div data-bbox="1144 1533 1307 1575"> <p data-bbox="1144 1543 1177 1564">■ B</p>  </div> </div> <p data-bbox="1291 1600 1377 1617">JSKIA0055ZZ</p>
 <p data-bbox="402 1850 490 1866">JSKIA0052ZZ</p>	MIG seam weld / Point weld	 <p data-bbox="1291 1852 1377 1869">JSKIA0056ZZ</p>



# REPLACEMENT OPERATIONS

## < REMOVAL AND INSTALLATION >

- Front pillar butt joint can be determined anywhere within shaded area as shown in the figure. The best location for the butt joint is at position A due to the construction of the vehicle.

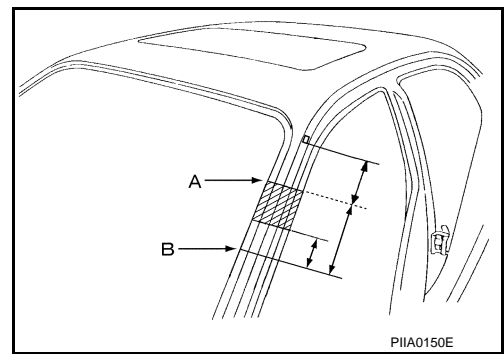

- Determine cutting position and record distance from the locating indent. Use this distance when cutting the service part. Cut outer front pillar over 60 mm (2.36 in) above the inner front pillar cut position.

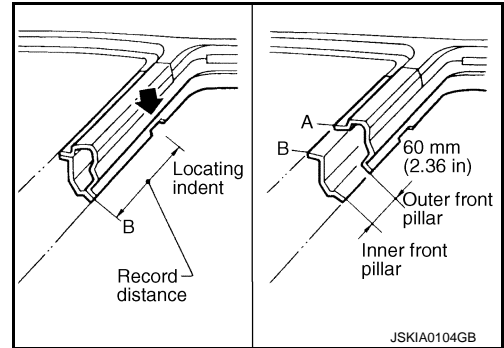

- Prepare a cutting jig to make outer pillar easier to cut. Also, this will permit the service part to be accurately cut at the joint position.

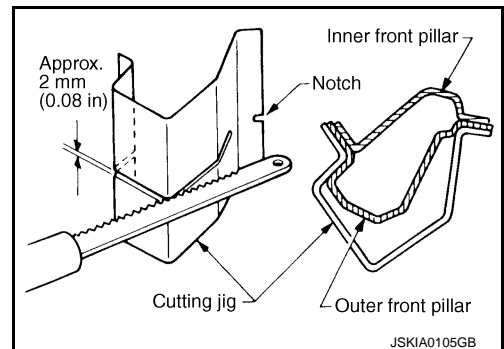

- An example of cutting operation using a cutting jig is as per the following.

1. Mark cutting lines.  
A: Cut position of outer pillar  
B: Cut position of inner pillar
2. Align cutting line with notch on jig. Clamp jig to pillar.
3. Cut outer pillar along groove of jig (at position A).
4. Remove jig and cut remaining portions.
5. Cut inner pillar at position B in same manner.

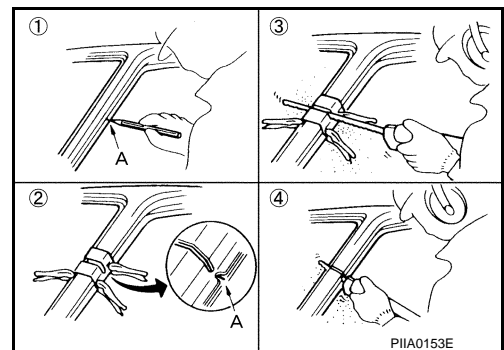

A  
B  
C  
D  
E  
F  
G  
H  
I  
J  
L  
M  
N  
O  
P

BRM

# REPLACEMENT OPERATIONS

< REMOVAL AND INSTALLATION >

## Radiator Core Support

INFOID:00000009750263

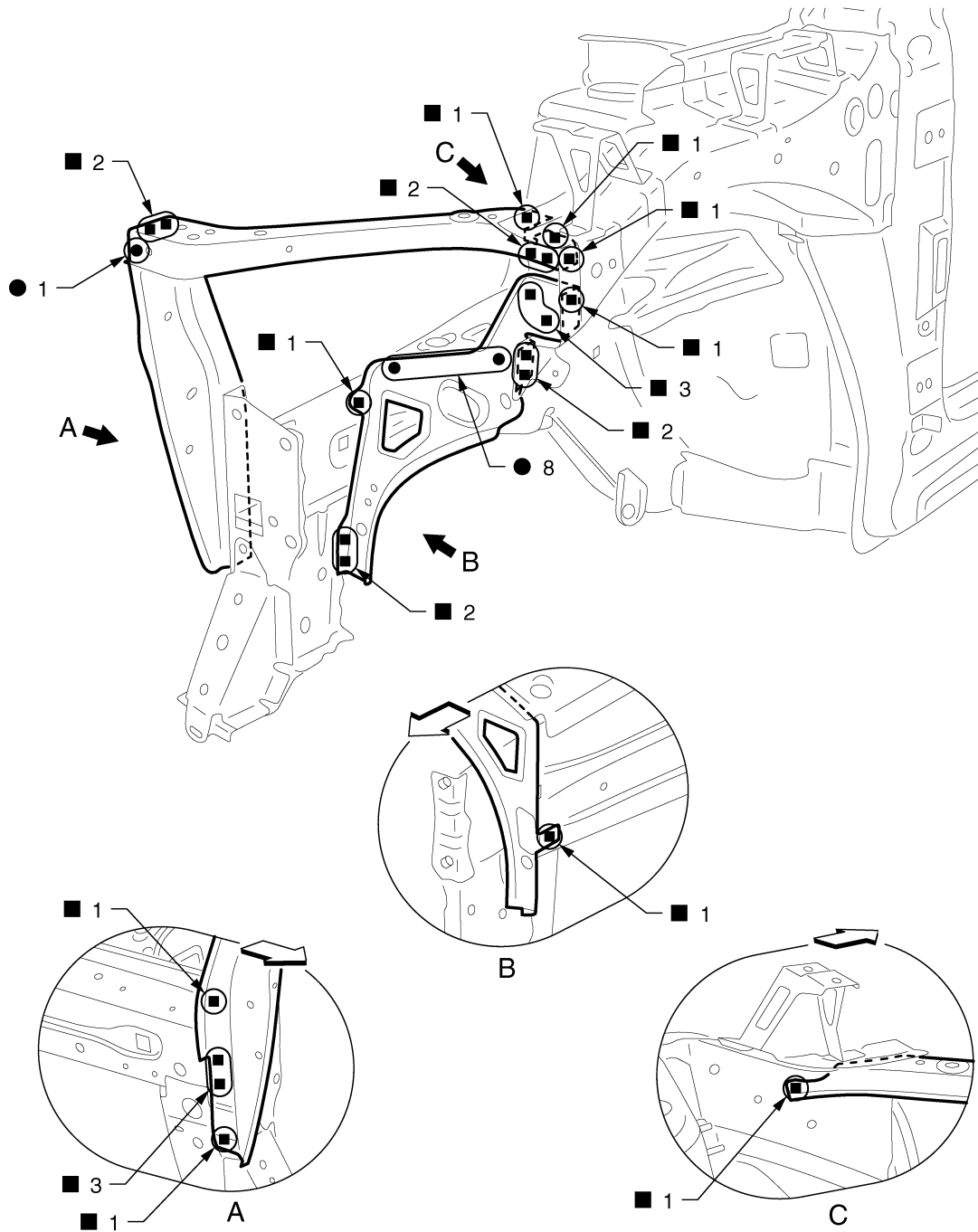

JSKIA2008ZZ

←: Vehicle front

Replacement parts

- Side radiator core support (LH Upper)
- Side radiator core support (LH Lower)
- Hoodledge connector (LH)

## Hoodledge

INFOID:00000009750264

Work after radiator core support is removed.

# REPLACEMENT OPERATIONS

## < REMOVAL AND INSTALLATION >

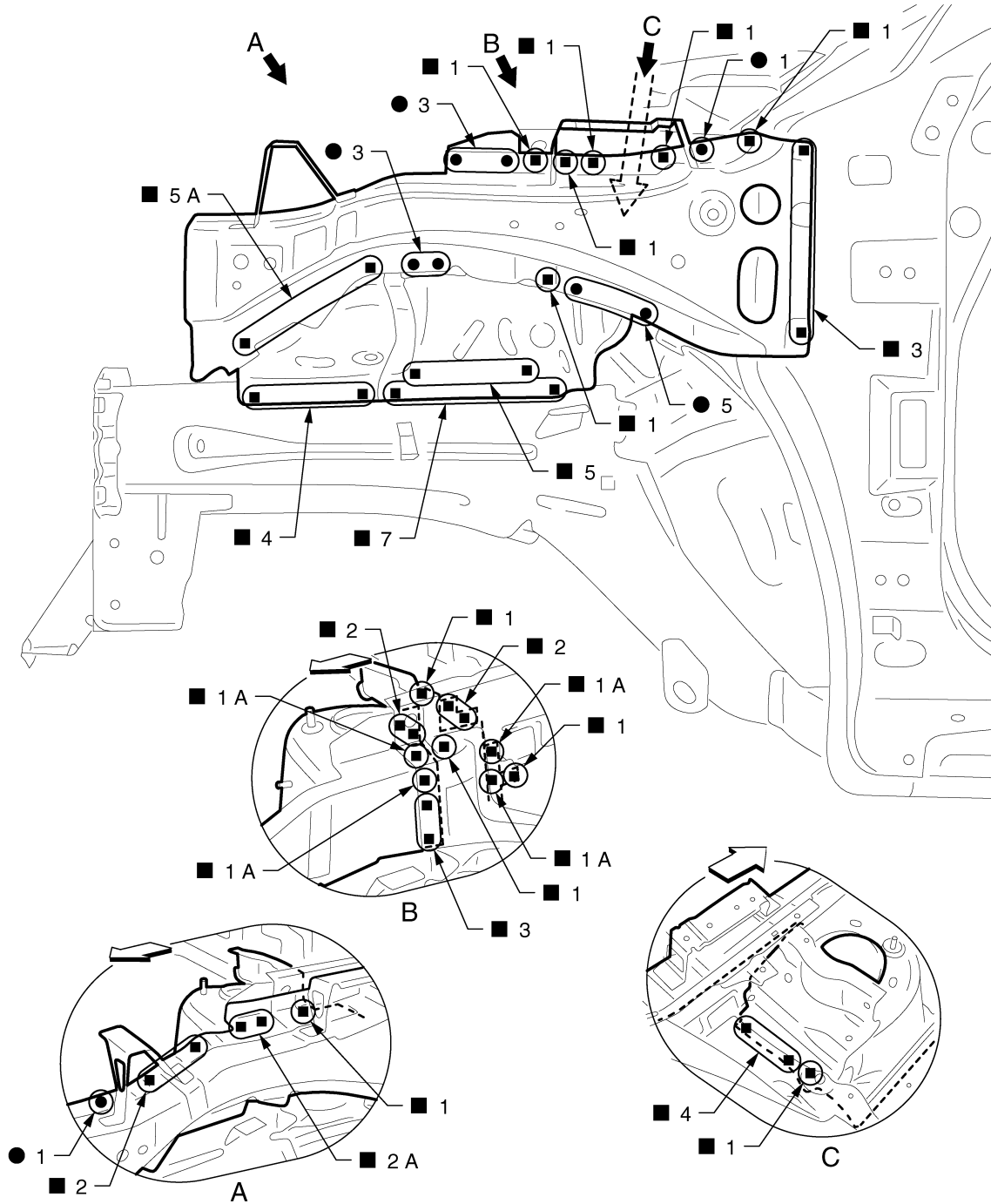

JSKIA2157ZZ

←: Vehicle front

Replacement parts

● Front strut housing (LH)

● Hoodledge reinforcement (LH)

View B: Before installing hoodledge reinforcement

### Hoodledge (Partial Replacement)

Work after radiator core support is removed.  
Remove the welding points "f" for easier installation.

INFOID:000000009750265

A  
B  
C  
D  
E  
F  
G  
H  
I  
J  
K  
L  
M  
N  
O  
P

BRM

# REPLACEMENT OPERATIONS

## < REMOVAL AND INSTALLATION >

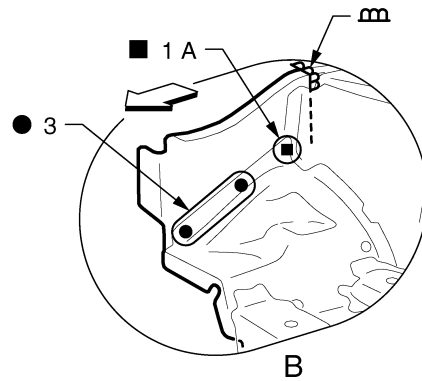
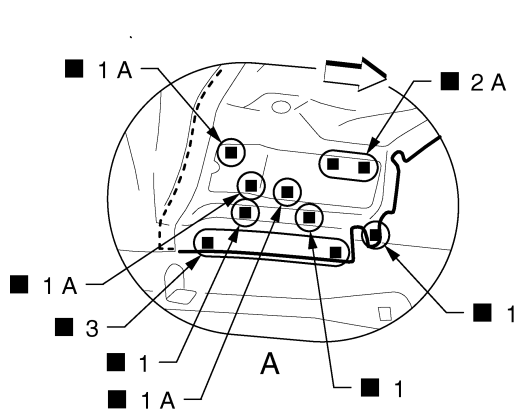
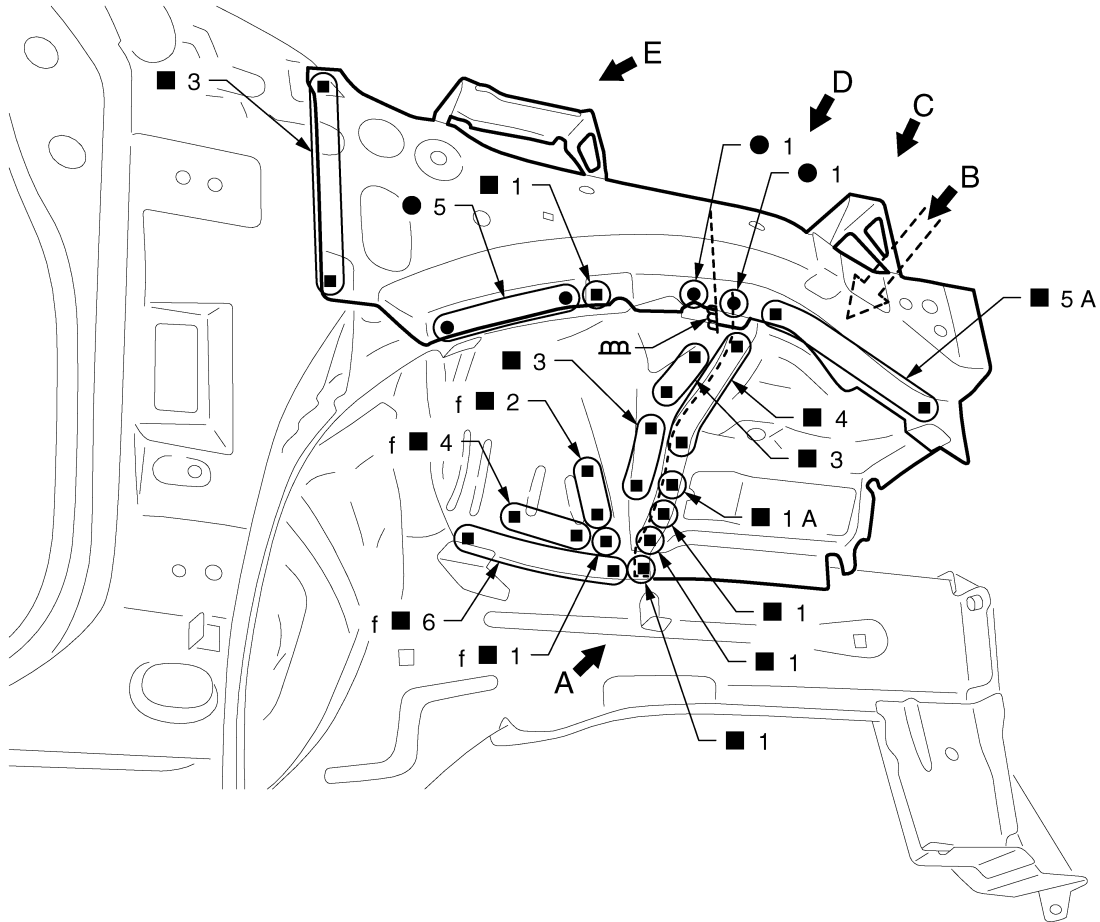

JSKIA2158ZZ

←: Vehicle front

Replacement parts

● Upper hoodlug (RH)

● Lower front hoodlug (RH)

● Hoodlug reinforcement (RH)

View B: Before installing hoodlug reinforcement

# REPLACEMENT OPERATIONS

## < REMOVAL AND INSTALLATION >

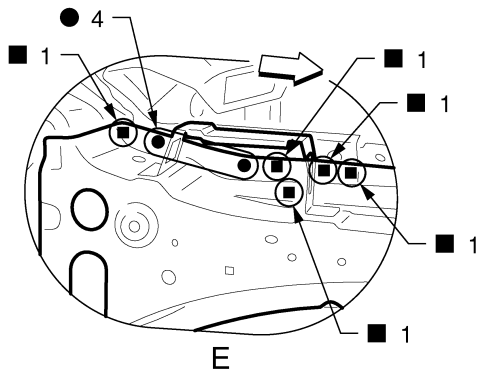
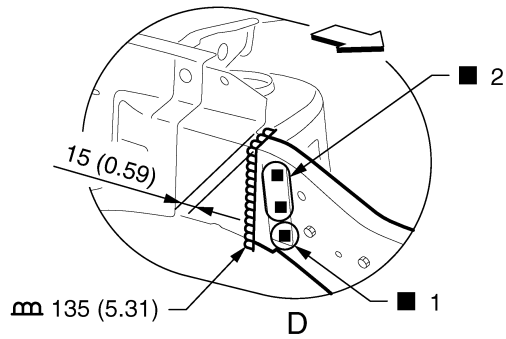
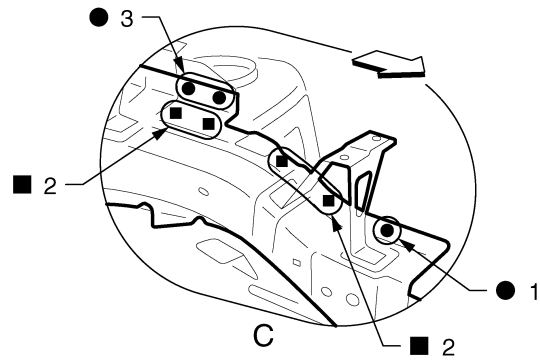

Unit: mm (in)

←: Vehicle front

View D: Before installing hoodledge reinforcement

### Front Side Member

Work after radiator core support and hoodledge are removed.

JSKIA2159GB

INFOID:000000009750266

A  
B  
C  
D  
E  
F  
G  
H  
I  
J  
K  
L  
M  
N  
O  
P

BRM

# REPLACEMENT OPERATIONS

## < REMOVAL AND INSTALLATION >

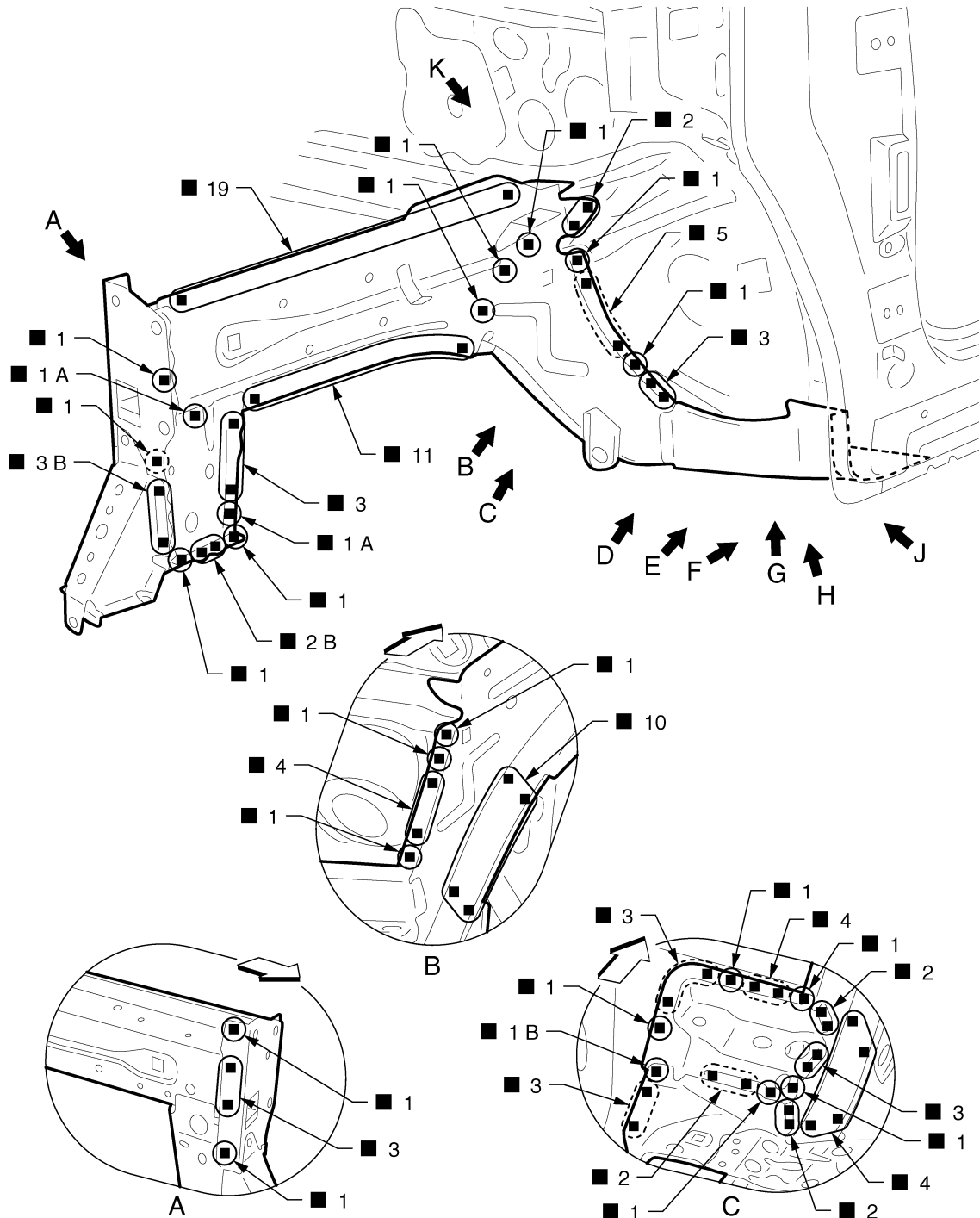

JSKIA2165ZZ

← Vehicle front

○ Weld the parts onto the back of the component part.

Replacement parts

- Front side member assembly (LH)
- Front side member closing plate assembly (LH)
- Front suspension mounting bracket (LH Rear)

# REPLACEMENT OPERATIONS

## < REMOVAL AND INSTALLATION >

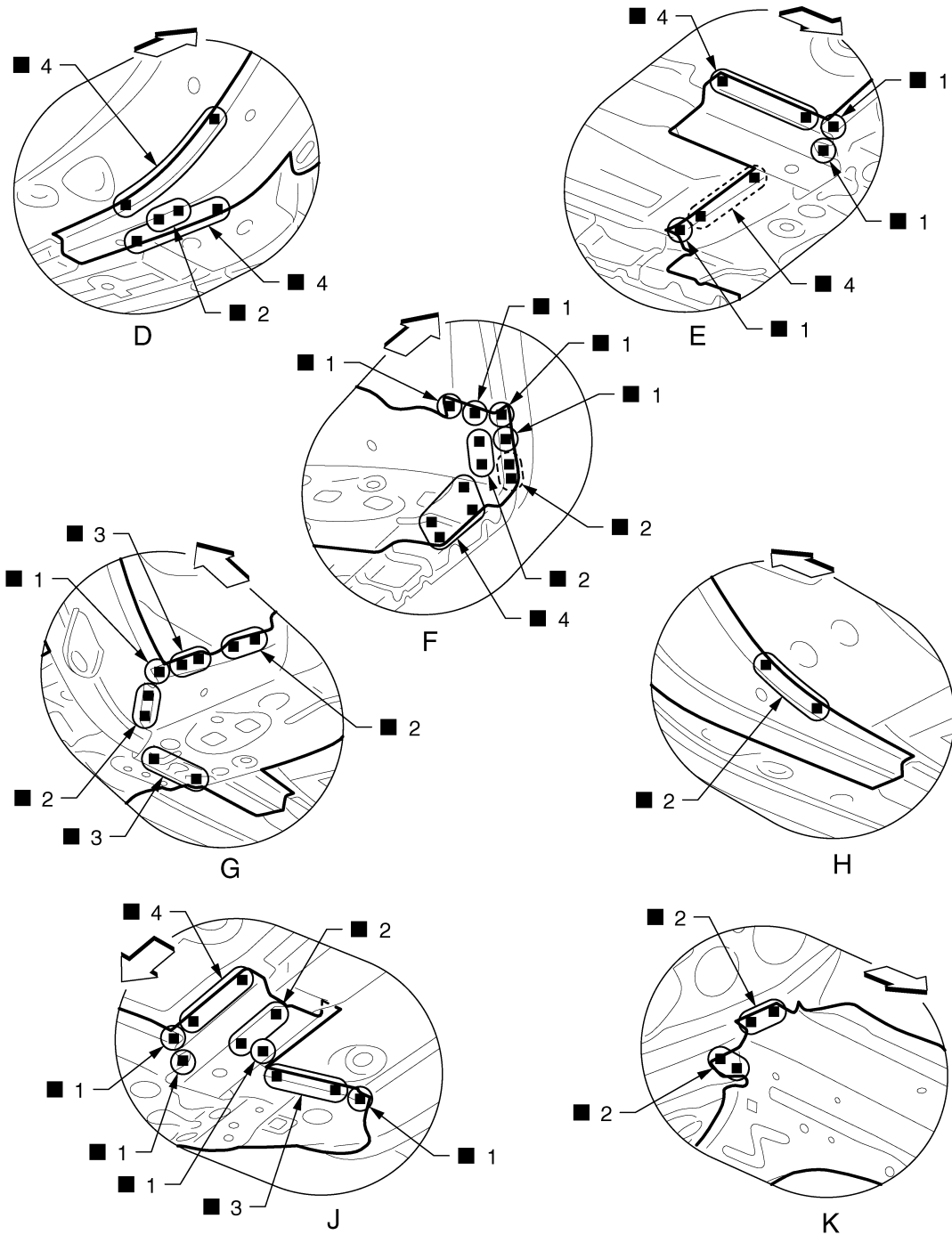

JSKIA2164ZZ

← Vehicle front

○: Weld the parts onto the back of the component part.

View D and H: Before installing front suspension mounting bracket (Rear)

### Front Side Member (Partial Replacement)

Work after radiator core support is removed.

A  
B  
C  
D  
E  
F  
G  
H  
I  
J  
K  
L  
M  
N  
O  
P

BRM

INFOID:000000009750267

# REPLACEMENT OPERATIONS

## < REMOVAL AND INSTALLATION >

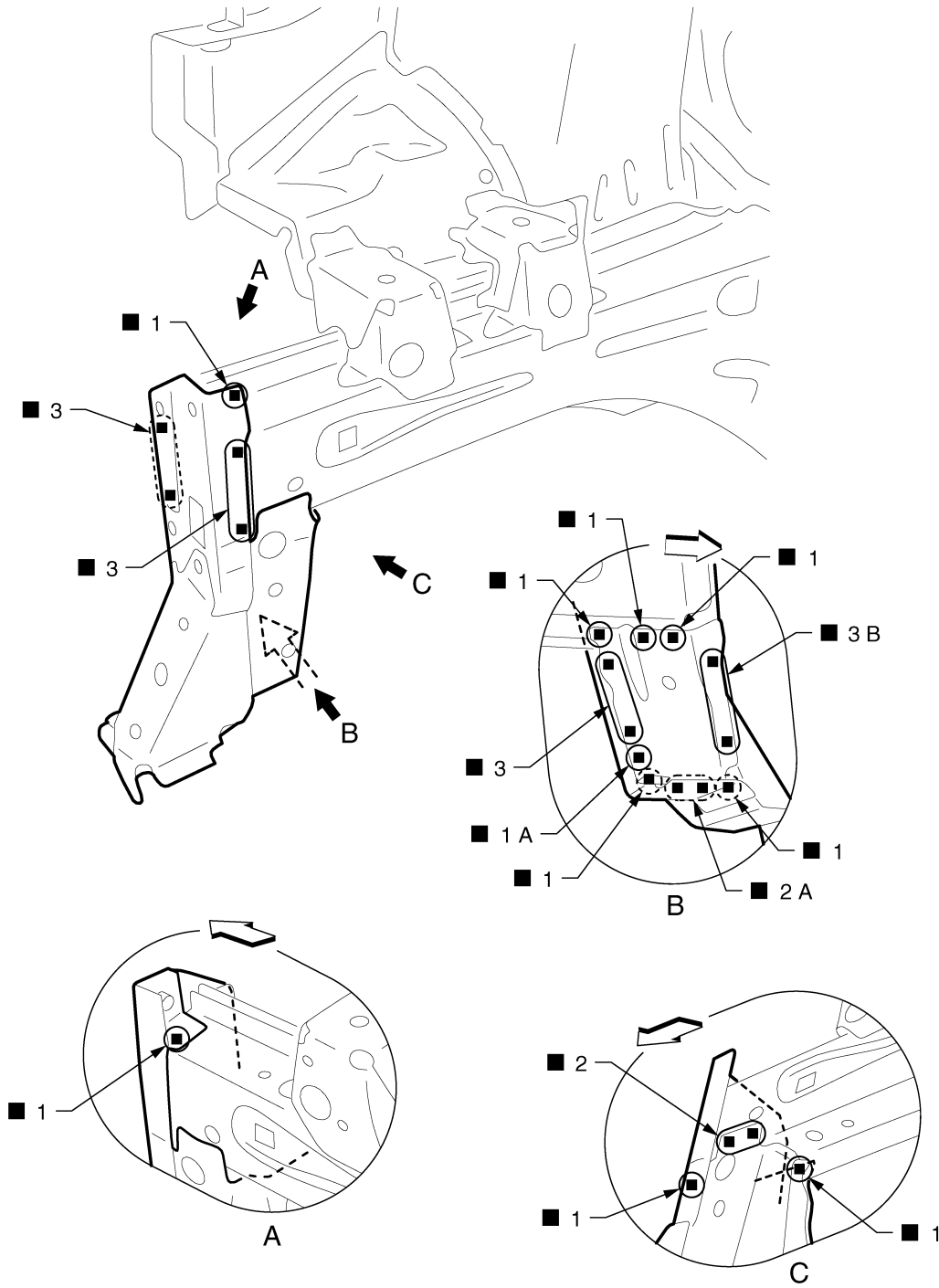

JSKIA2013ZZ

←: Vehicle front

(○): Weld the parts onto the back of the component part.

Replacement parts

- Front suspension mounting bracket (RH Front)
- Add on frame bracket (RH)

### POINT

The front side member on the left can also be replaced partially by butt welding.



# REPLACEMENT OPERATIONS

## < REMOVAL AND INSTALLATION >

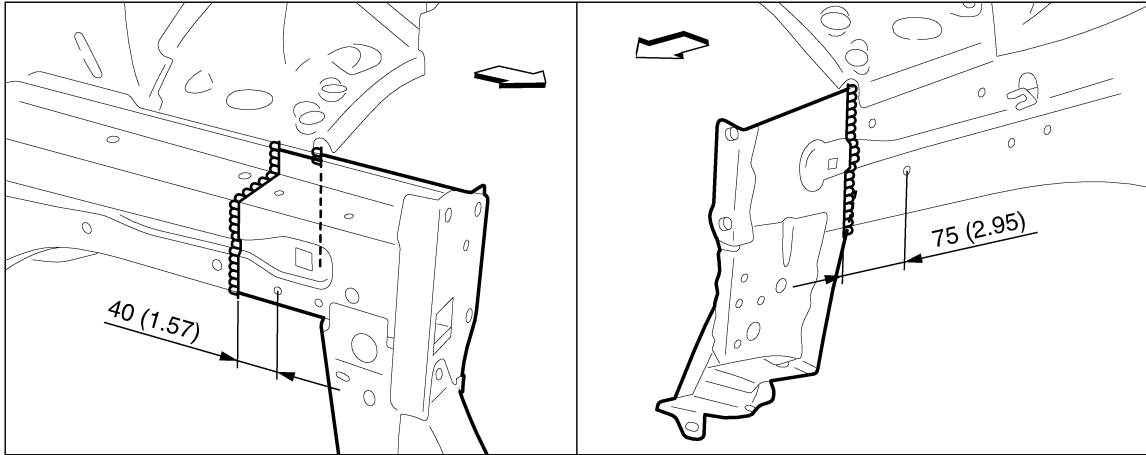

JSKIA2014GB

Unit: mm (in)

⇐: Vehicle front

Replacement parts

- Front side member assembly (LH)
- Front side member closing plate assembly (LH)

### NOTE:

For welding method and the number of welding points, refer to [BRM-37, "Front Side Member"](#).

## Front Pillar

INFOID:000000009750268

Work after hoodledge reinforcement is removed.

A  
B  
C  
D  
E  
F  
G  
H  
I  
J  
L  
M  
N  
O  
P

BRM

# REPLACEMENT OPERATIONS

< REMOVAL AND INSTALLATION >

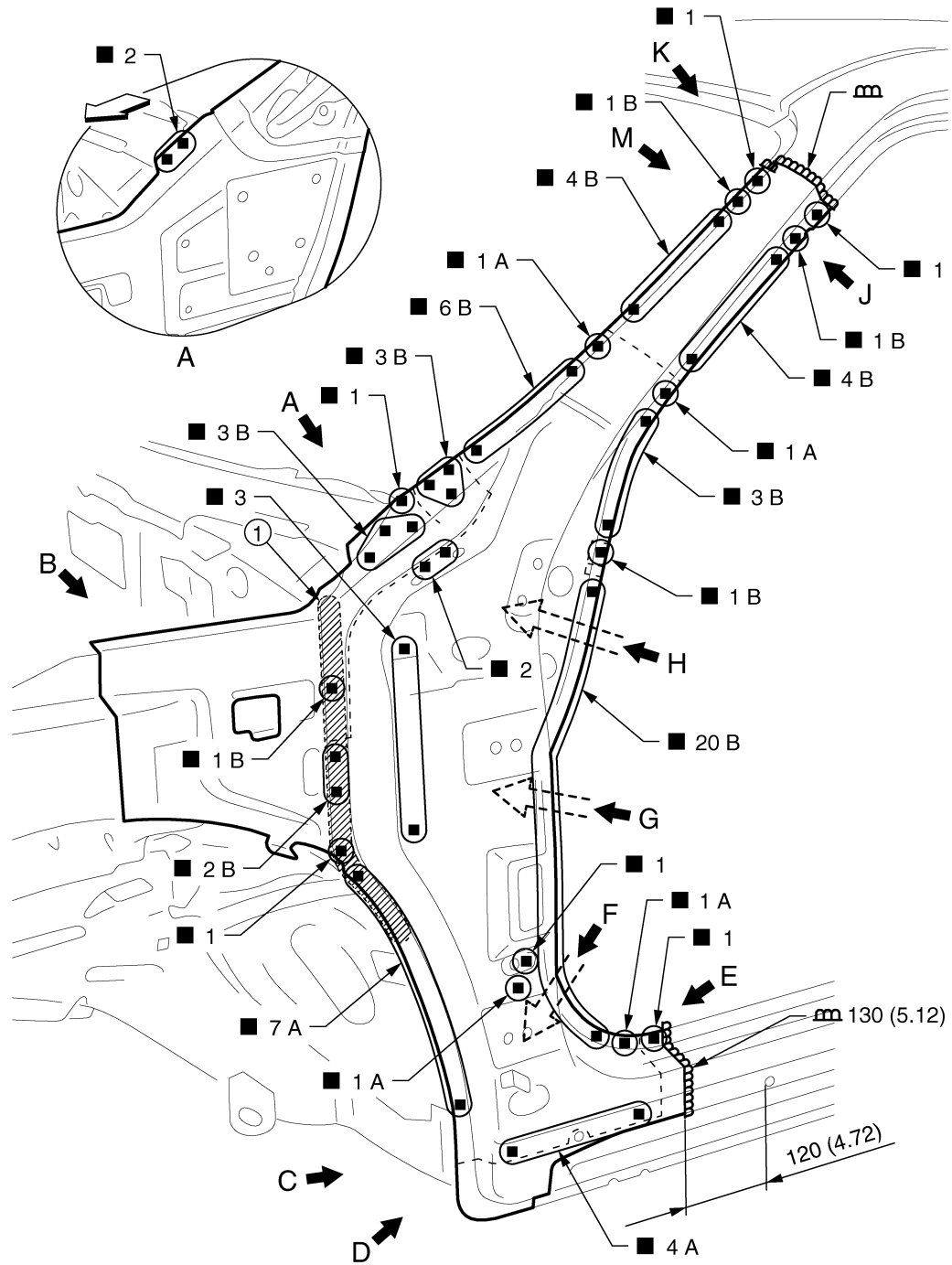

JSKIA2168GB

1. Body sealing

Unit: mm (in)

◁: Vehicle front

Replacement parts

- Outer front side body (LH)
- Front pillar brace (LH)
- Side dash (LH)
- Upper inner front pillar (LH)
- Front fender bracket assembly (LH)

View A: Before installing outer front side body, front fender bracket assembly, and front pillar brace

# REPLACEMENT OPERATIONS

## < REMOVAL AND INSTALLATION >

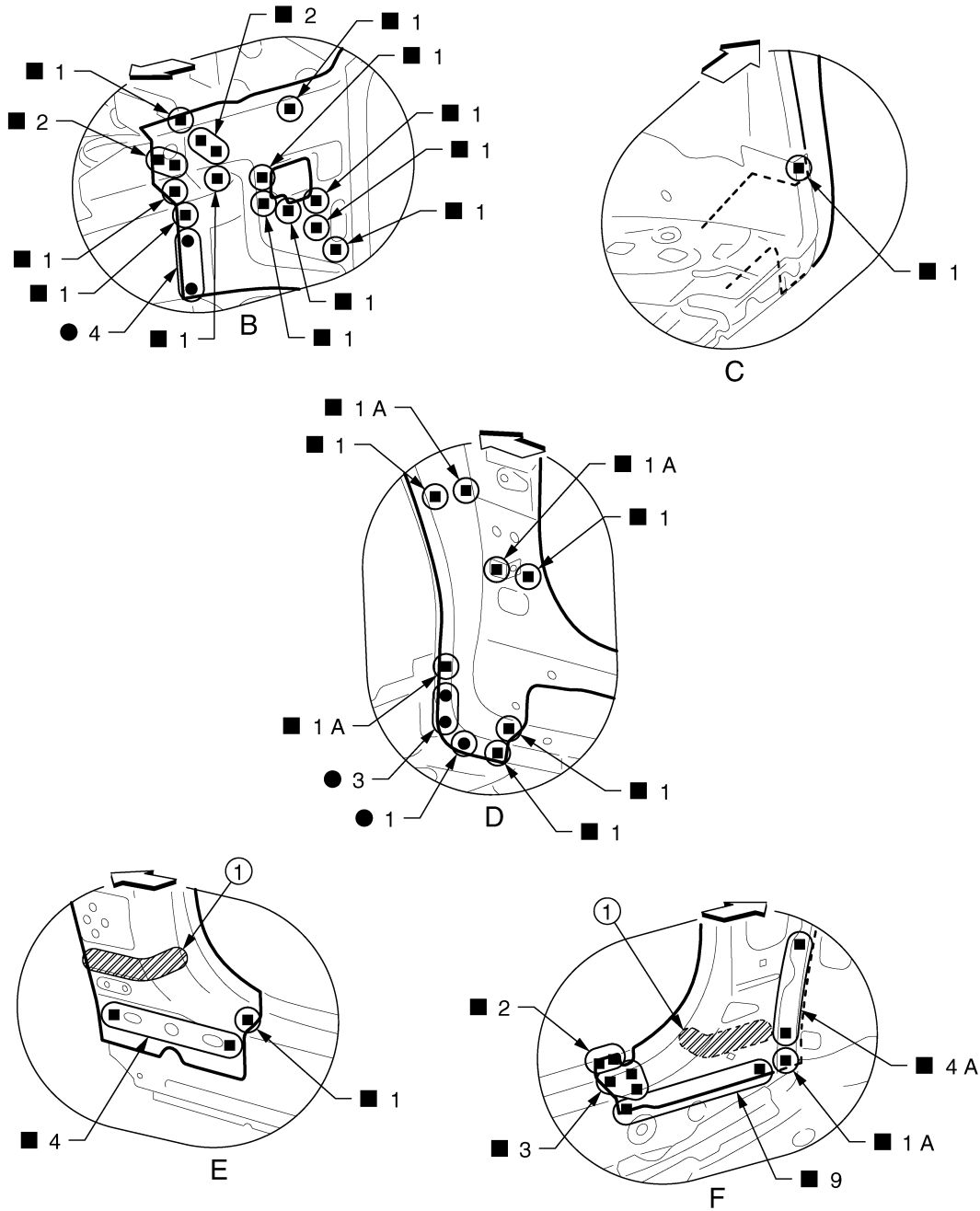

1. Urethane foam

←: Vehicle front

View E: Before installing outer front side body and front fender bracket assembly

JSKIA2210ZZ

A  
B  
C  
D  
E  
F  
G  
H  
I  
J  
BRM  
L  
M  
N  
O  
P

# REPLACEMENT OPERATIONS

## < REMOVAL AND INSTALLATION >

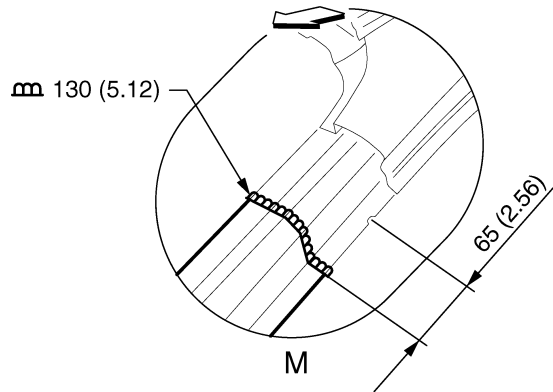
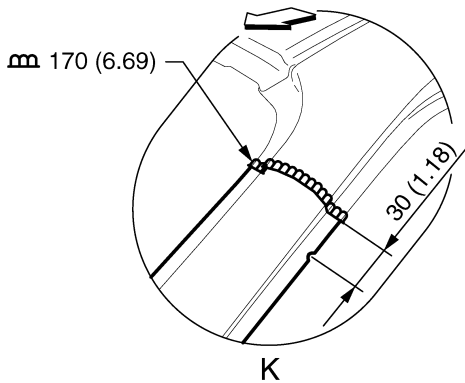
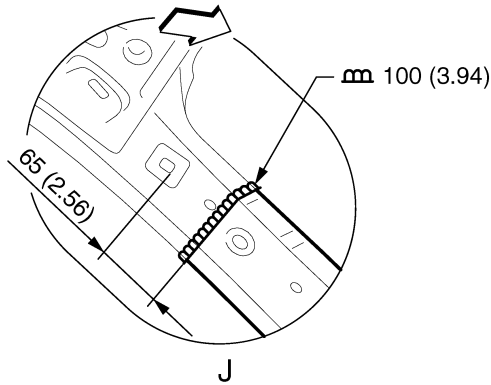
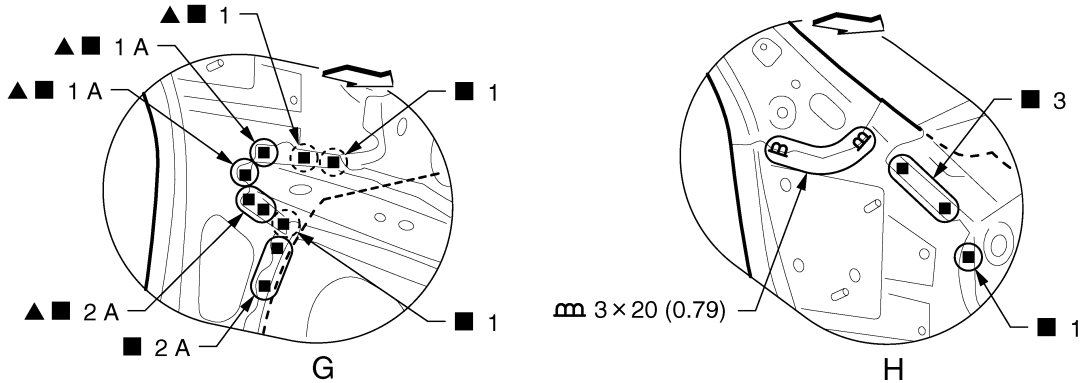

JSKIA2170GB

Unit: mm (in)

↔: Vehicle front

▲: Drill  $\phi 9$  mm (0.35 in) hole for the plug welding hole (ultra high strength steel plate).

○: Weld the parts onto the back of the component part.

View G: Before installing outer front side body, front fender bracket assembly, and front pillar brace

View M: Before installing outer front side body

### Center Pillar (Standard Roof Models)

INFOID:000000009750269

Remove the outer sill reinforcement (reusable).

# REPLACEMENT OPERATIONS

< REMOVAL AND INSTALLATION >

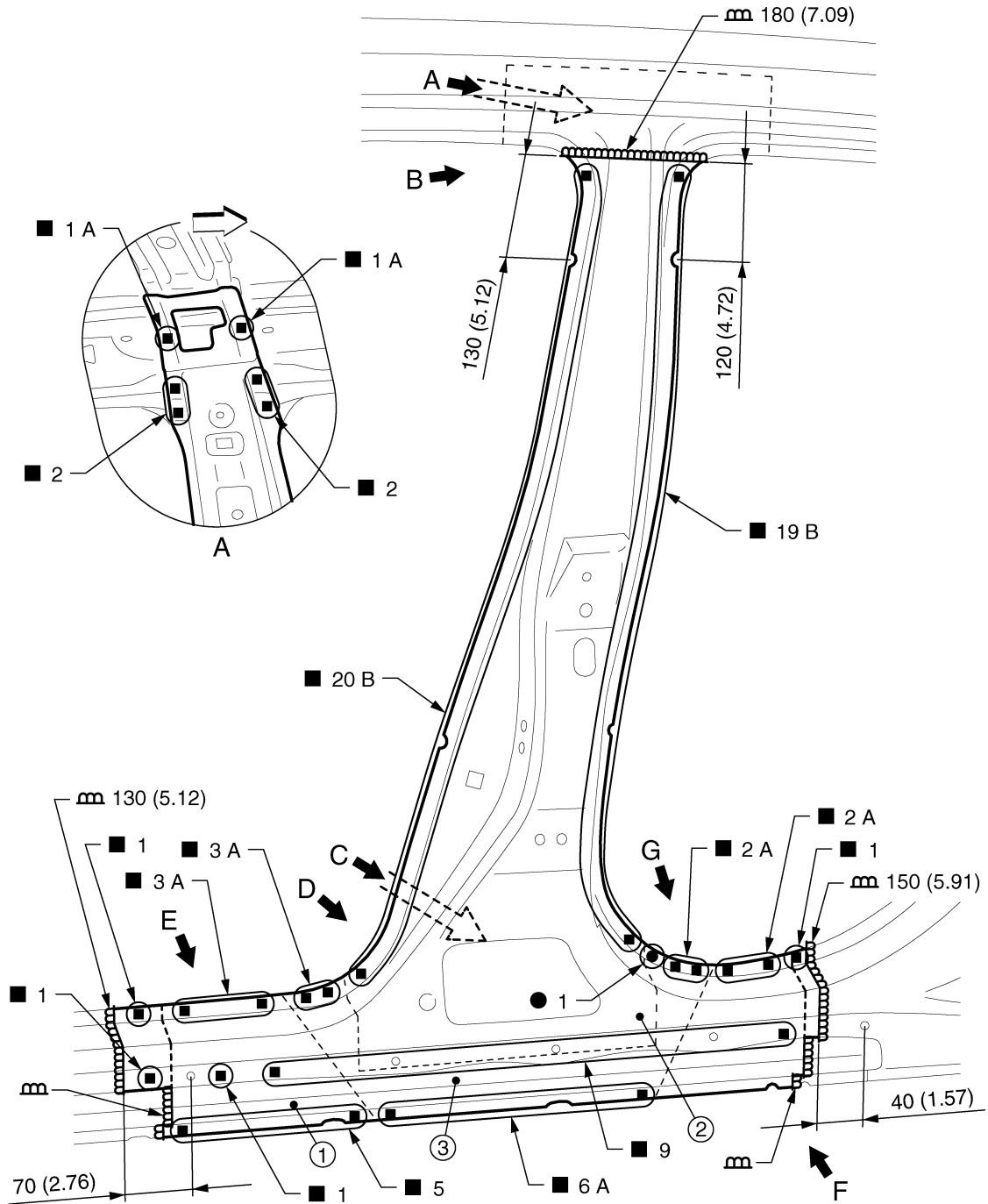

JSKIA2171GB

- |  |                              |                        |
|--|------------------------------|------------------------|
| 1. Outer sill reinforcement (reusable) | 2. Lower center pillar brace | 3. Inner center pillar |
|--|------------------------------|------------------------|
- Unit: mm (in)
- ◁: Vehicle front
- Replacement parts
- |                              |                                  |                            |
|------------------------------|----------------------------------|----------------------------|
| ● Outer front side body (LH) | ● Lower center pillar brace (LH) | ● Inner center pillar (LH) |
|------------------------------|----------------------------------|----------------------------|

A  
B  
C  
D  
E  
F  
G  
H  
I  
J  
BRM  
L  
M  
N  
O  
P

# REPLACEMENT OPERATIONS

## < REMOVAL AND INSTALLATION >

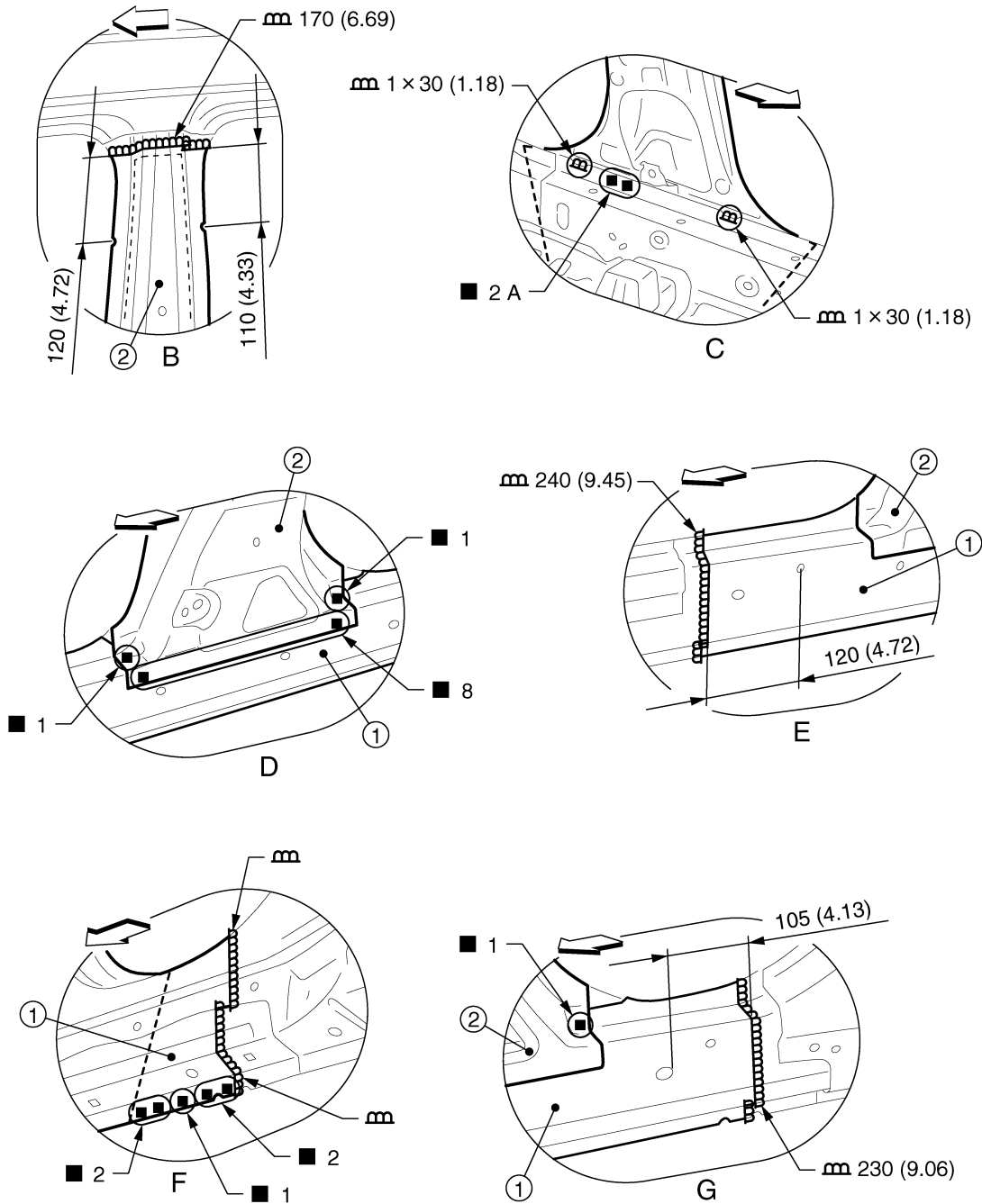

JSKIA2172GB

1. Outer sill reinforcement (reusable)    2. Lower center pillar brace  
Unit: mm (in)

↔: Vehicle front

View B, D, E, and G: Before installing outer front side body  
**Center Pillar (With Sunroof Models)**

INFOID:000000009750270

Remove the outer sill reinforcement (reusable).

# REPLACEMENT OPERATIONS

< REMOVAL AND INSTALLATION >

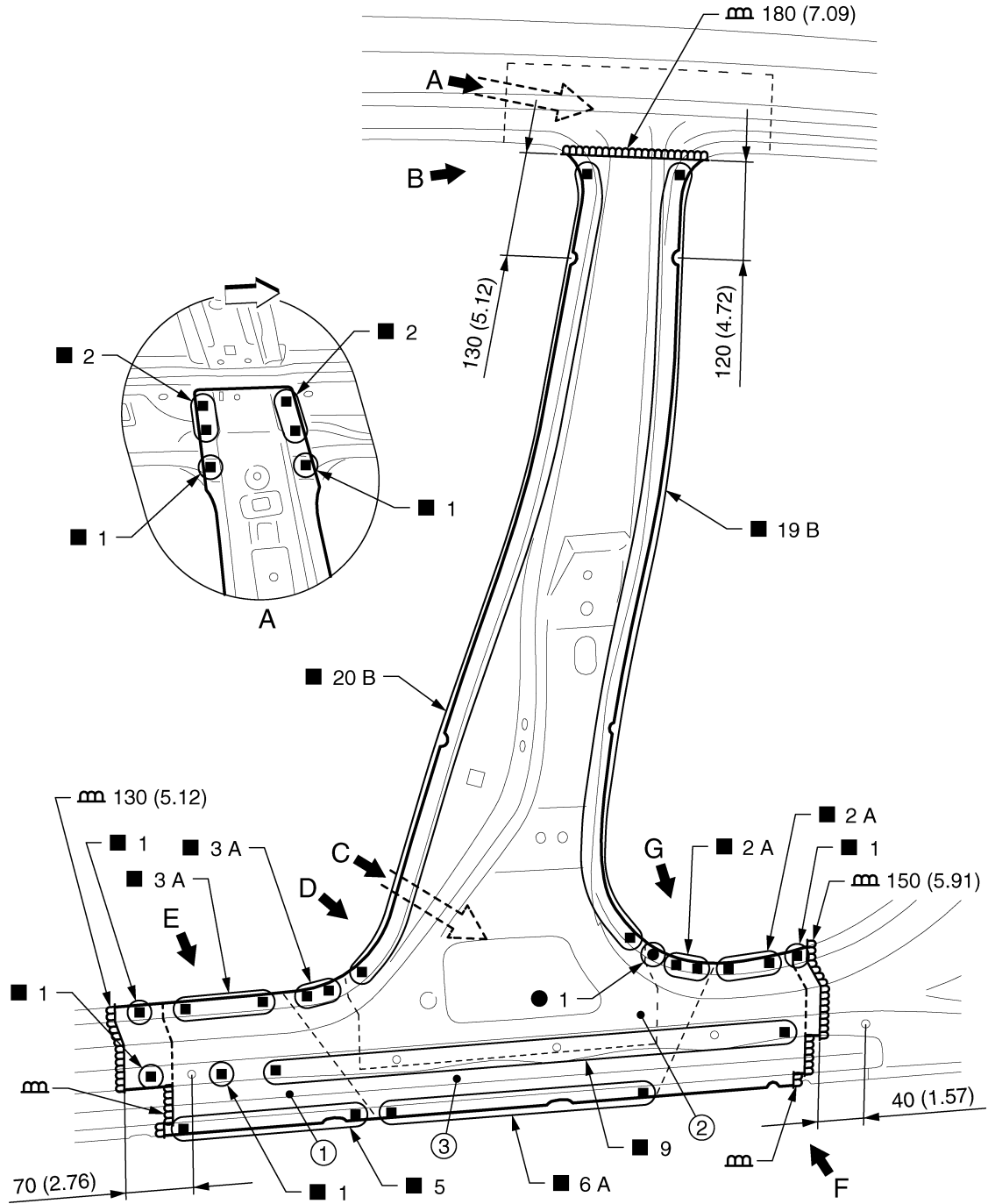

JSKIA2018GB

- 1. Outer sill reinforcement (reusable)
- 2. Lower center pillar brace
- 3. Inner center pillar

Unit: mm (in)

←: Vehicle front

Replacement parts

- Outer front side body (LH)
- Lower center pillar brace (LH)
- Inner center pillar (LH)

A  
B  
C  
D  
E  
F  
G  
H  
I  
J  
K  
L  
M  
N  
O  
P

BRM

# REPLACEMENT OPERATIONS

## < REMOVAL AND INSTALLATION >

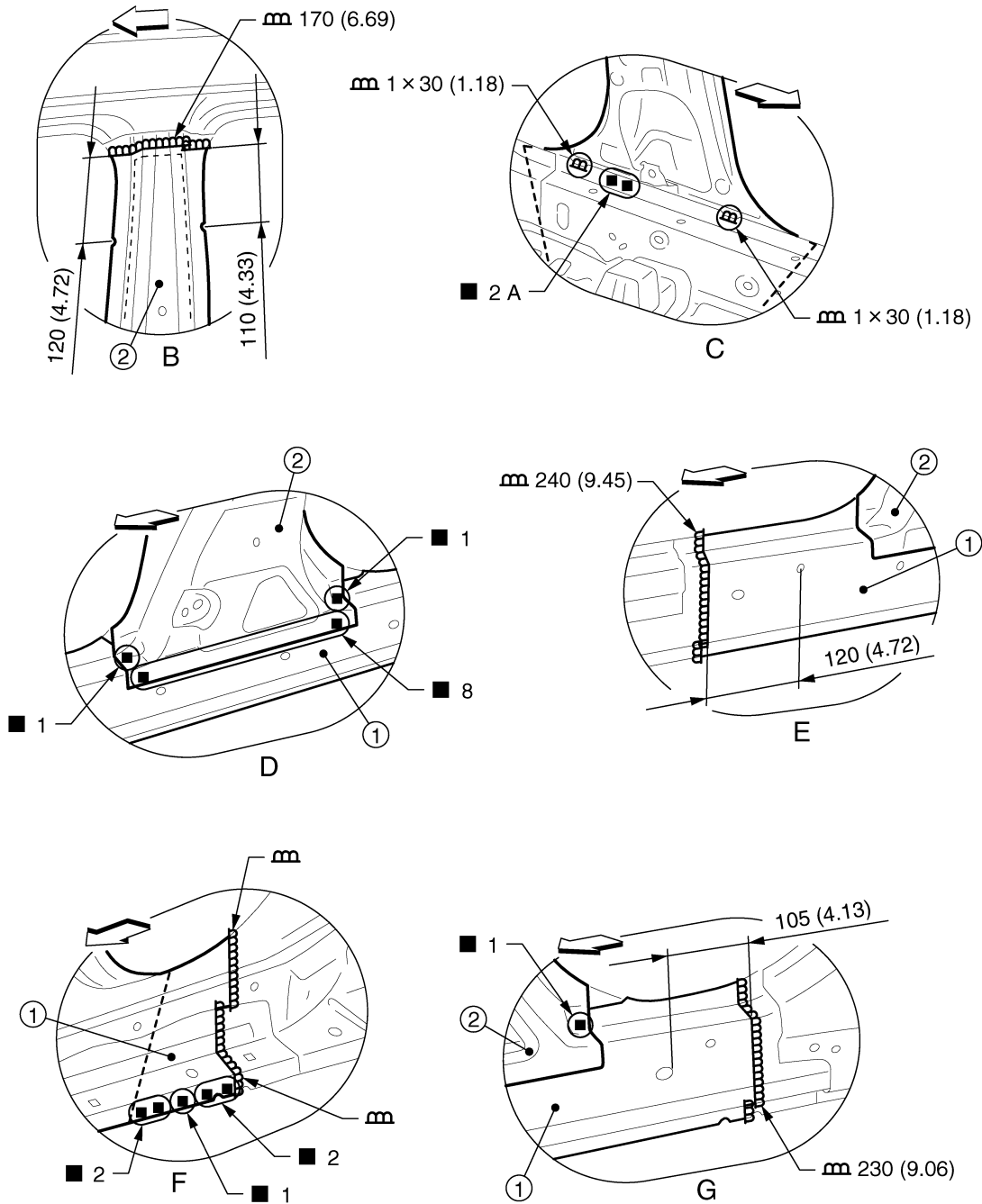

JSKIA2172GB

1. Outer sill reinforcement (reusable)    2. Lower center pillar brace  
 Unit: mm (in)

↔: Vehicle front

View B, D, E, and G: Before installing outer front side body



# REPLACEMENT OPERATIONS

< REMOVAL AND INSTALLATION >

## Outer Sill (Partial Replacement)

INFOID:000000009750271

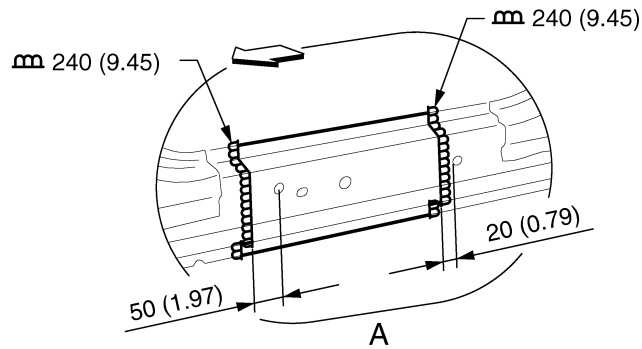
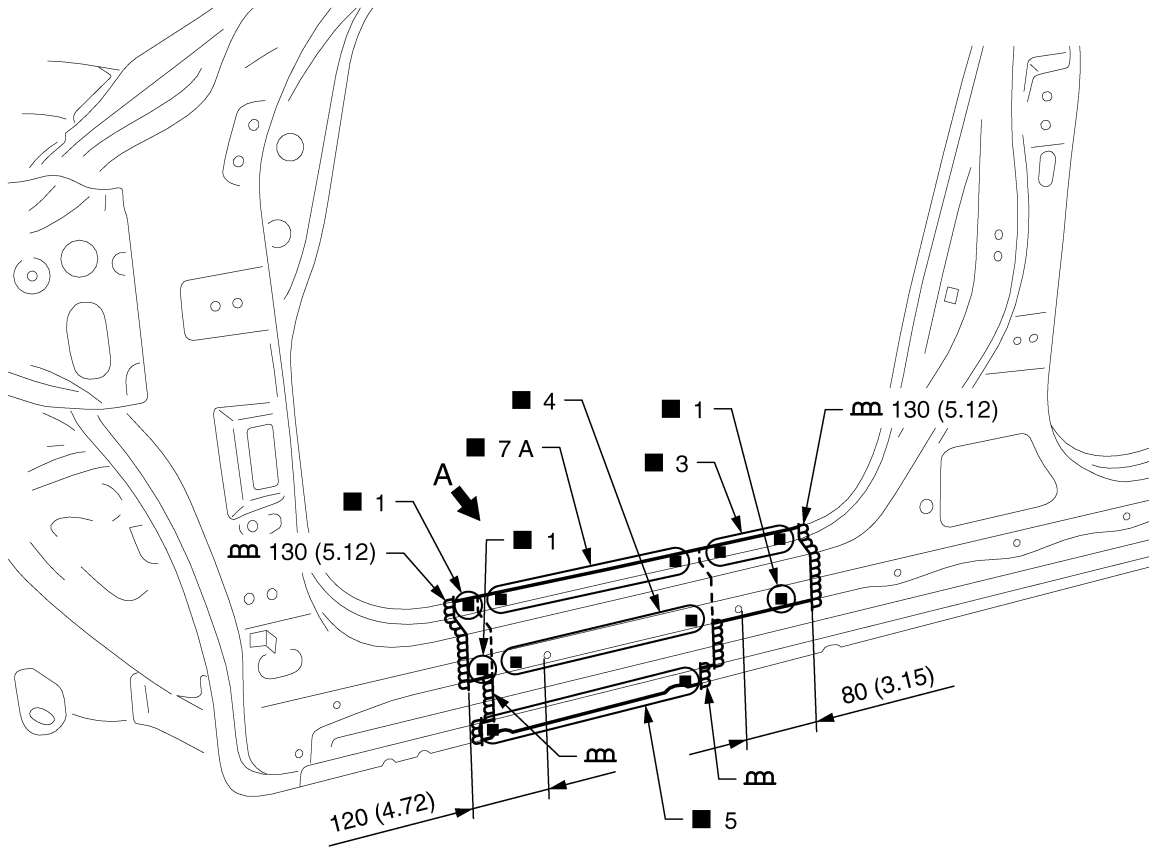

Unit: mm (in)

↔: Vehicle front

Replacement parts

● Outer sill (LH)

● Outer sill reinforcement (LH)

View A: Before installing outer sill

A  
B  
C  
D  
E  
F  
G  
H  
I  
J  
K  
L  
M  
N  
O  
P

BRM

JSKIA2020GB

# REPLACEMENT OPERATIONS

< REMOVAL AND INSTALLATION >

## Outer Sill

INFOID:00000009750272

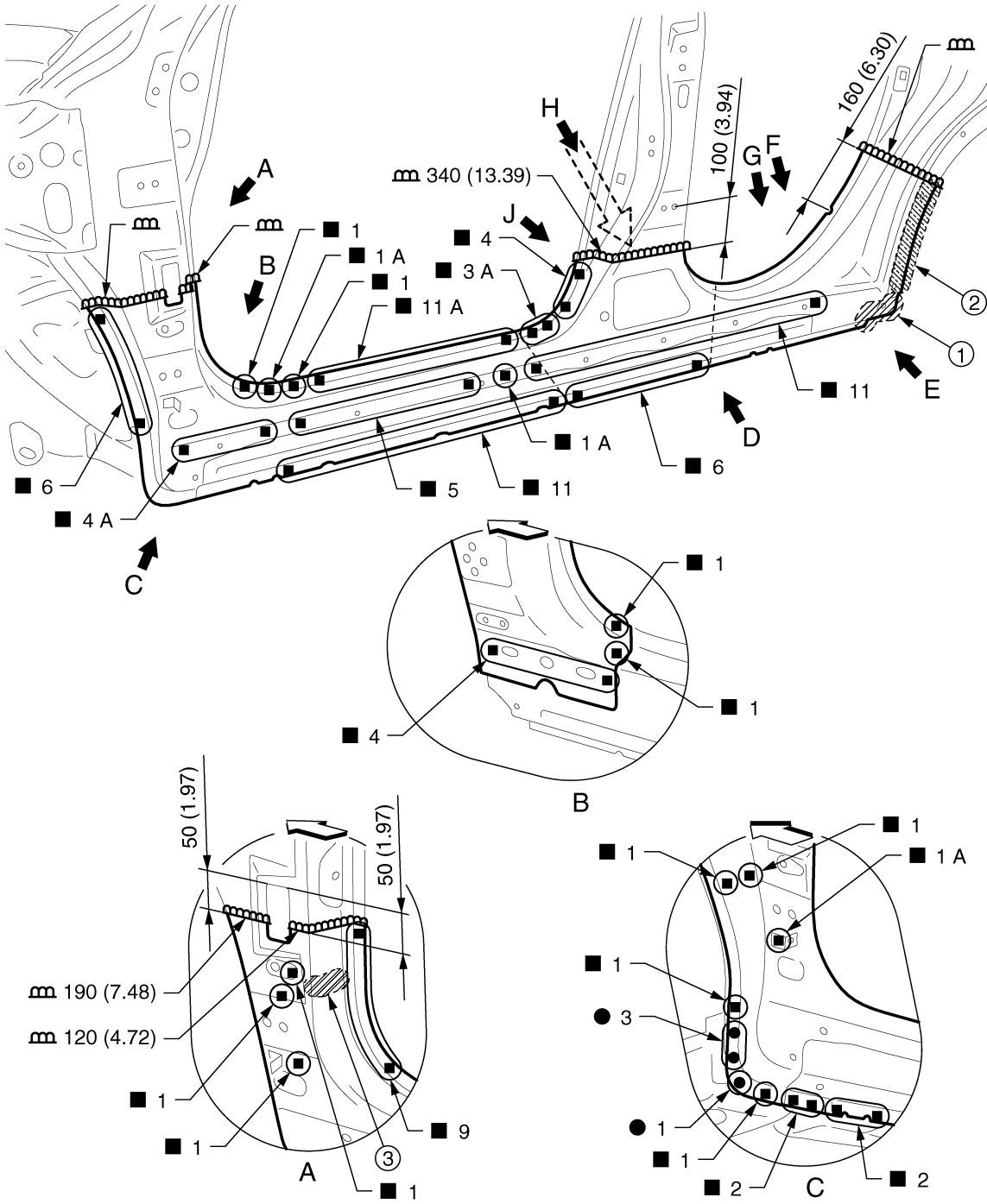

JSKIA2175GB

- 1. Body sealing
  - 2. Adhesive
  - 3. Urethane foam
- Unit: mm (in)
- ◁: Vehicle front
- Replacement parts
- Outer sill (LH)
  - Outer sill reinforcement (LH)
  - Front fender bracket assembly (LH)

View B: Before installing outer sill and front fender bracket assembly



## REPLACEMENT OPERATIONS

### < REMOVAL AND INSTALLATION >

- Perform the hemming to the flange of wheelarch after applying the adhesive.
- Apply the sealing to the flange end.
- Refer to [BRM-30. "Rear Fender Hemming Process"](#).

1. **Outer rear wheelhouse**
2. **Rear fender**
3. **Adhesive**
4. **Sealant**

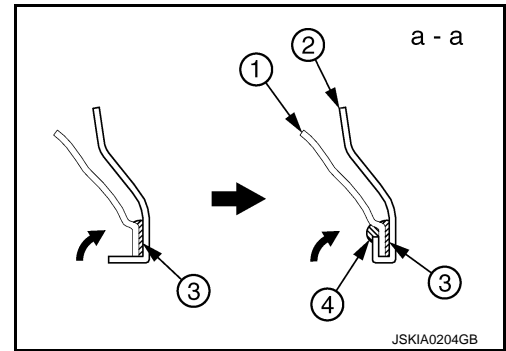

# REPLACEMENT OPERATIONS

< REMOVAL AND INSTALLATION >

## Rear Fender (2WD Models)

INFOID:000000009750273

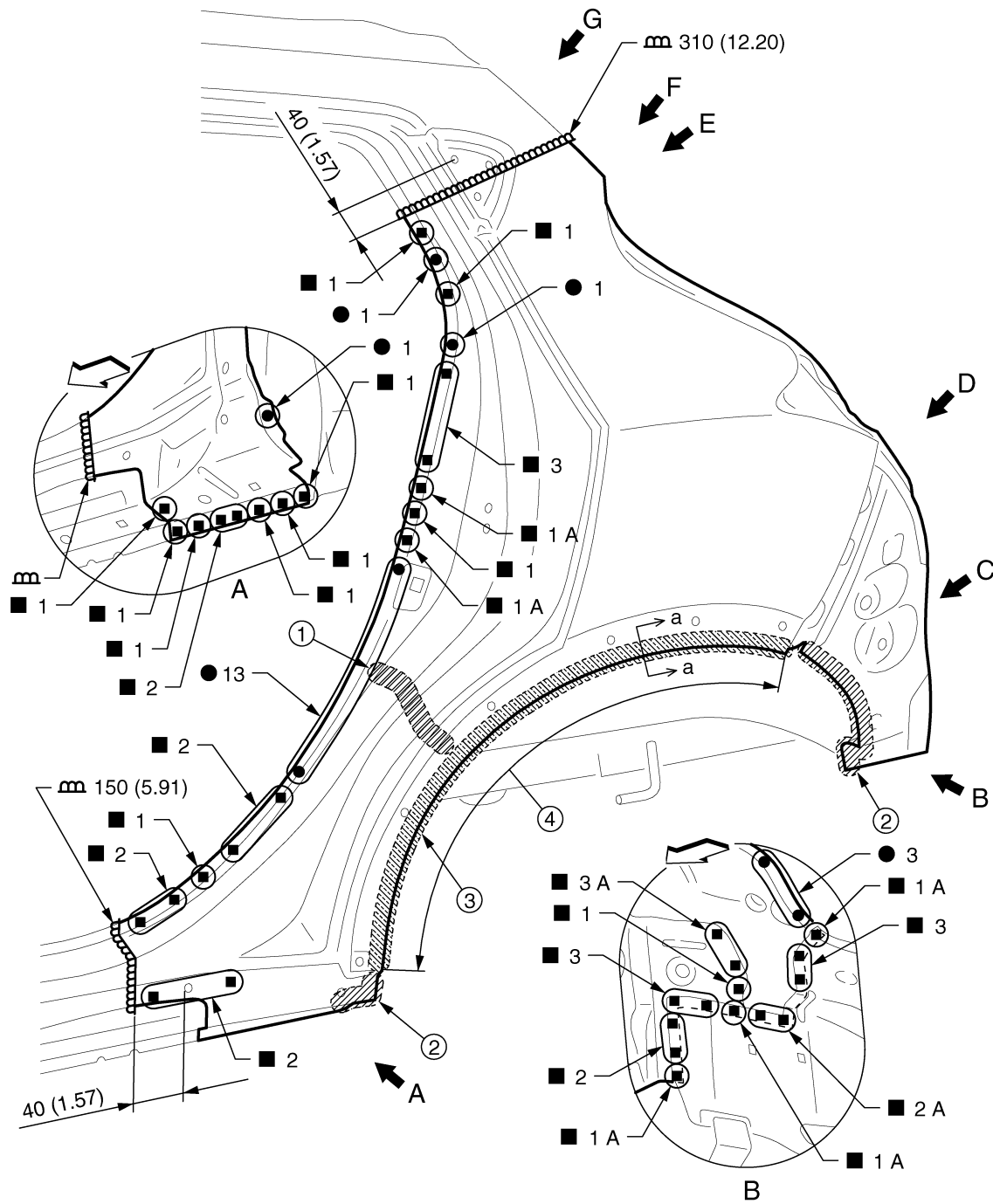

- 1. Urethane foam
- 4. Hemming portion

- 2. Body sealing

- 3. Adhesive

Unit: mm (in)

← Vehicle front

Replacement parts

● Rear fender (LH)

● Rear fender extension (LH)

● Rear fender corner (LH)

JSKIA2023GB

A  
B  
C  
D  
E  
F  
G  
H  
I  
J  
K  
L  
M  
N  
O  
P

BRM

# REPLACEMENT OPERATIONS

< REMOVAL AND INSTALLATION >

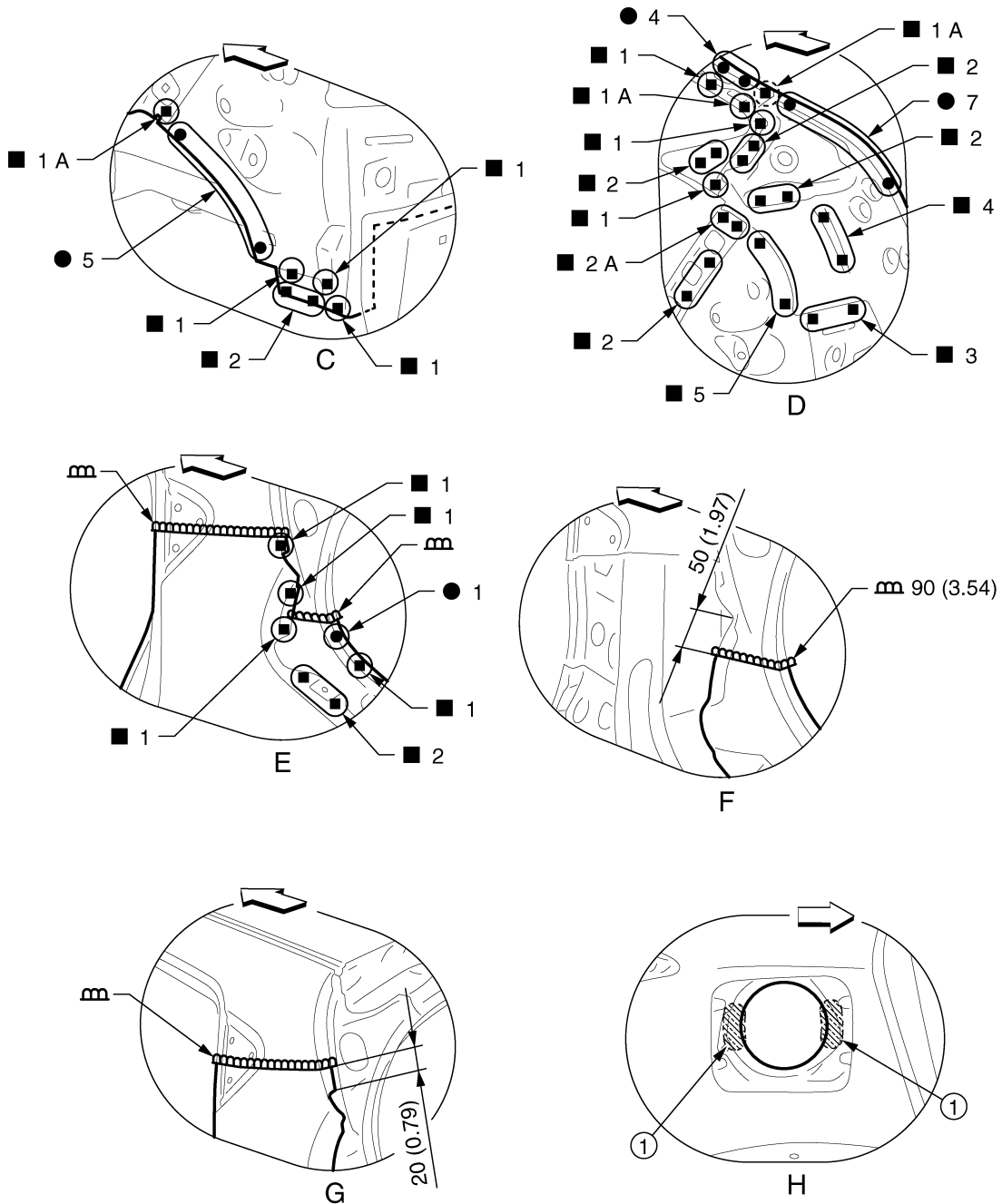

JSKIA2616GB

1. Adhesive

Unit: mm (in)

←: Vehicle front

(○): Weld the parts onto the back of the component part.

View F: Before installing rear fender

View H: Right side rear fender

POINT

# REPLACEMENT OPERATIONS

## < REMOVAL AND INSTALLATION >

- Perform the hemming to the flange of wheelarch after applying the adhesive.
- Apply the sealing to the flange end.
- Refer to [BRM-30. "Rear Fender Hemming Process"](#).

1. Outer rear wheelhouse
2. Rear fender
3. Adhesive
4. Sealant

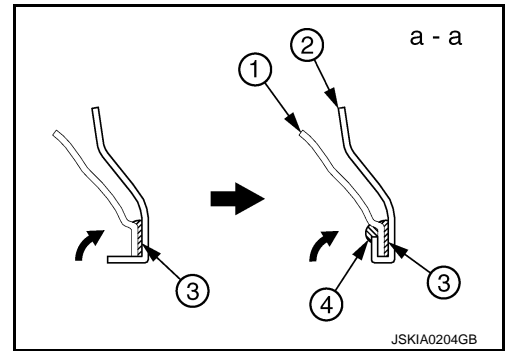

A  
B  
C  
D  
E  
F  
G  
H  
I  
J  
L  
M  
N  
O  
P

BRM

# REPLACEMENT OPERATIONS

< REMOVAL AND INSTALLATION >

## Rear Fender (AWD Models)

INFOID:00000009750274

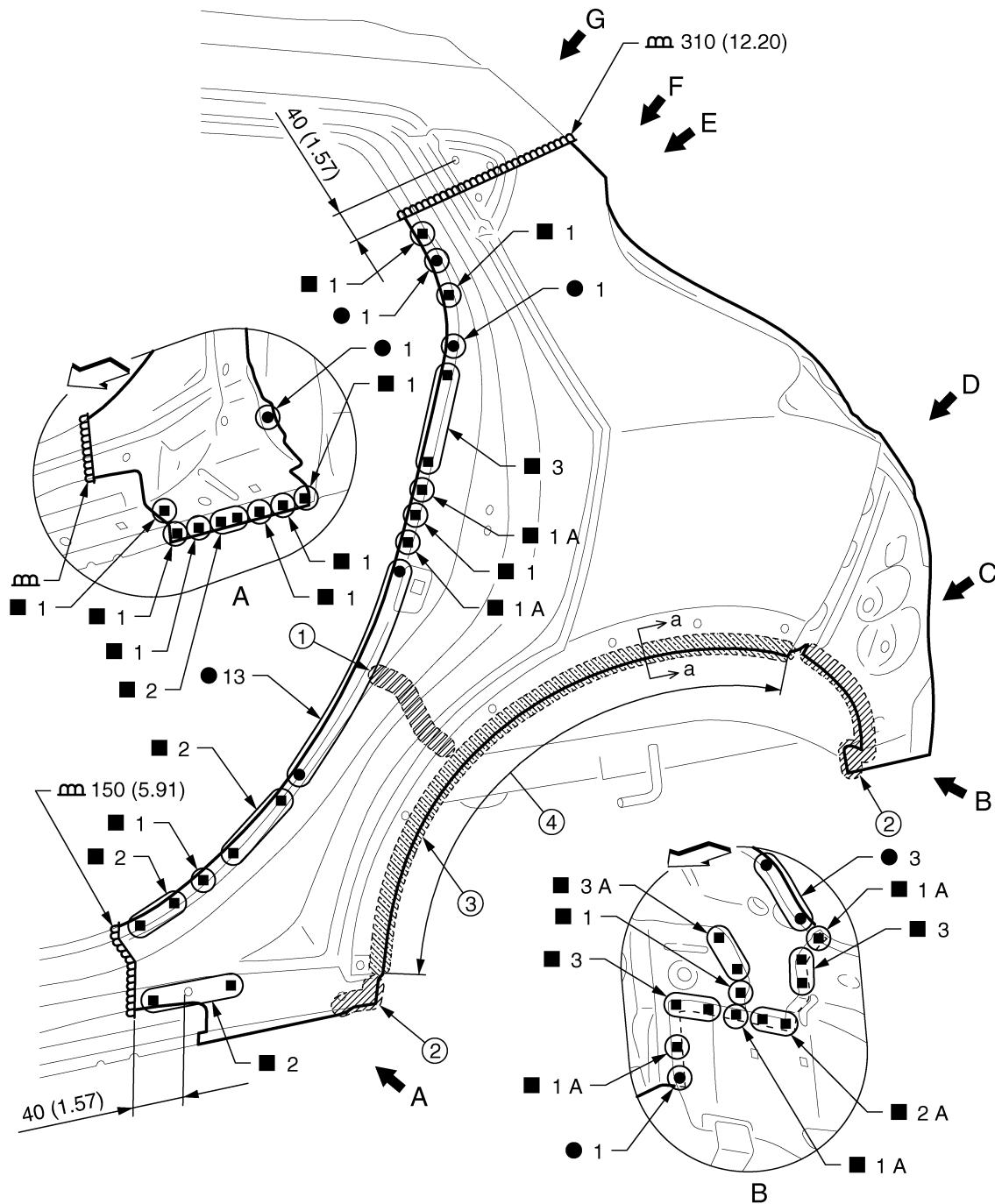

JSKIA2178GB

- 1. Urethane foam
  - 4. Hemming portion
- Unit: mm (in)

- 2. Body sealing

- 3. Adhesive

←: Vehicle front

Replacement parts

- Rear fender (LH)
- Rear fender extension (LH)
- Rear fender corner (LH)



# REPLACEMENT OPERATIONS

## < REMOVAL AND INSTALLATION >

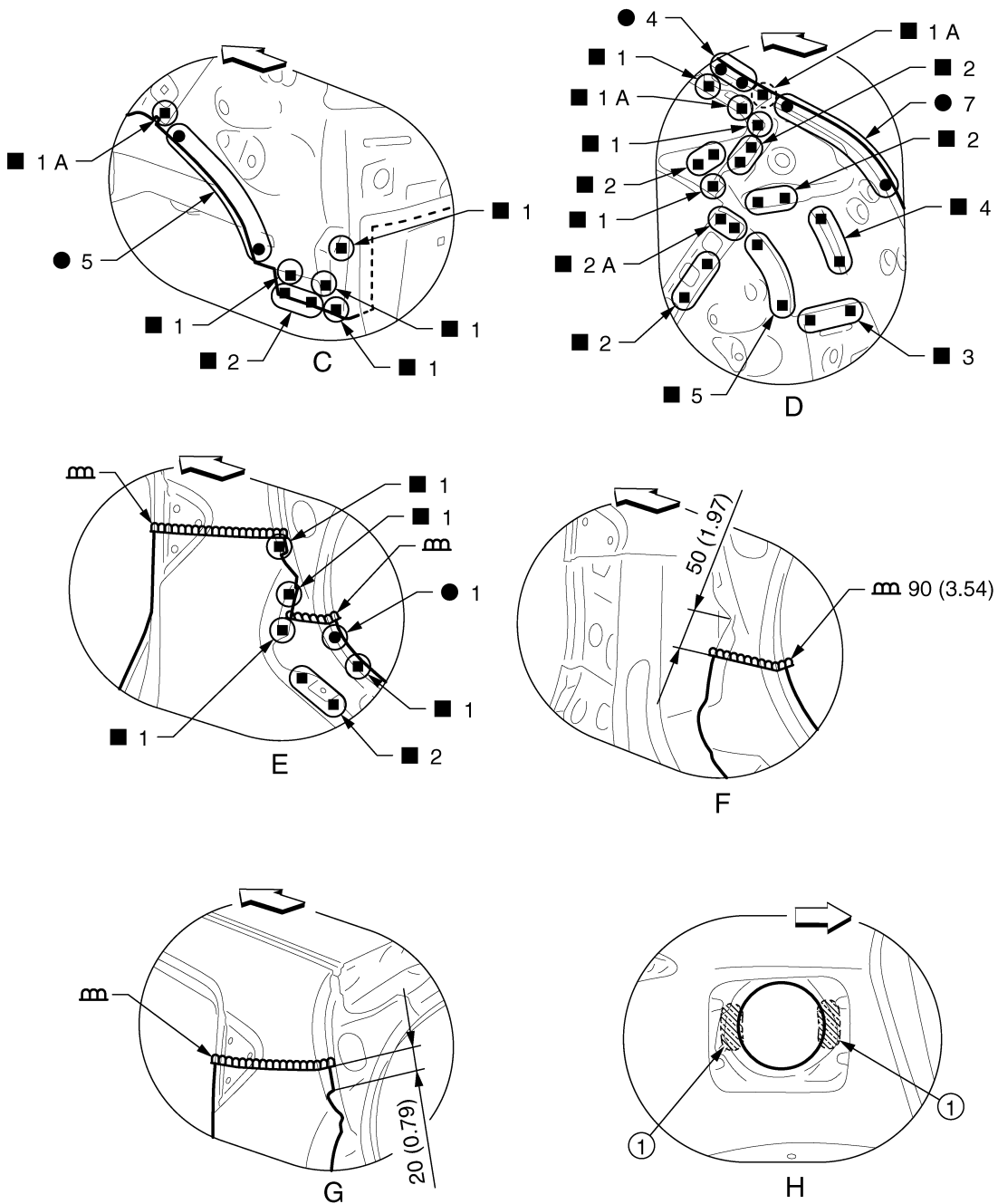

1. Adhesive

Unit: mm (in)

⇨: Vehicle front

(○): Weld the parts onto the back of the component part.

View F: Before installing rear fender

View H: Right side rear fender

POINT

A  
B  
C  
D  
E  
F  
G  
H  
I  
J  
BRM  
L  
M  
N  
O  
P

JSKIA2617GB

## REPLACEMENT OPERATIONS

### < REMOVAL AND INSTALLATION >

- Perform the hemming to the flange of wheelarch after applying the adhesive.
- Apply the sealing to the flange end.
- Refer to [BRM-30. "Rear Fender Hemming Process"](#).

1. **Outer rear wheelhouse**
2. **Rear fender**
3. **Adhesive**
4. **Sealant**

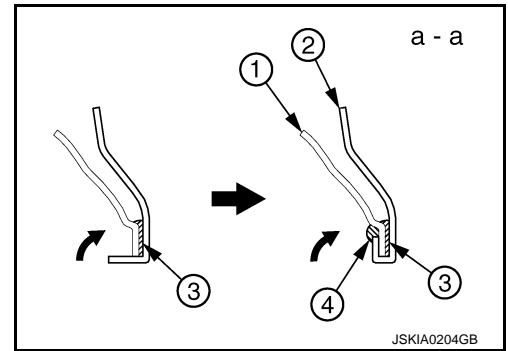

# REPLACEMENT OPERATIONS

< REMOVAL AND INSTALLATION >

## Rear Fender Extension (2WD Models)

INFOID:000000009750275

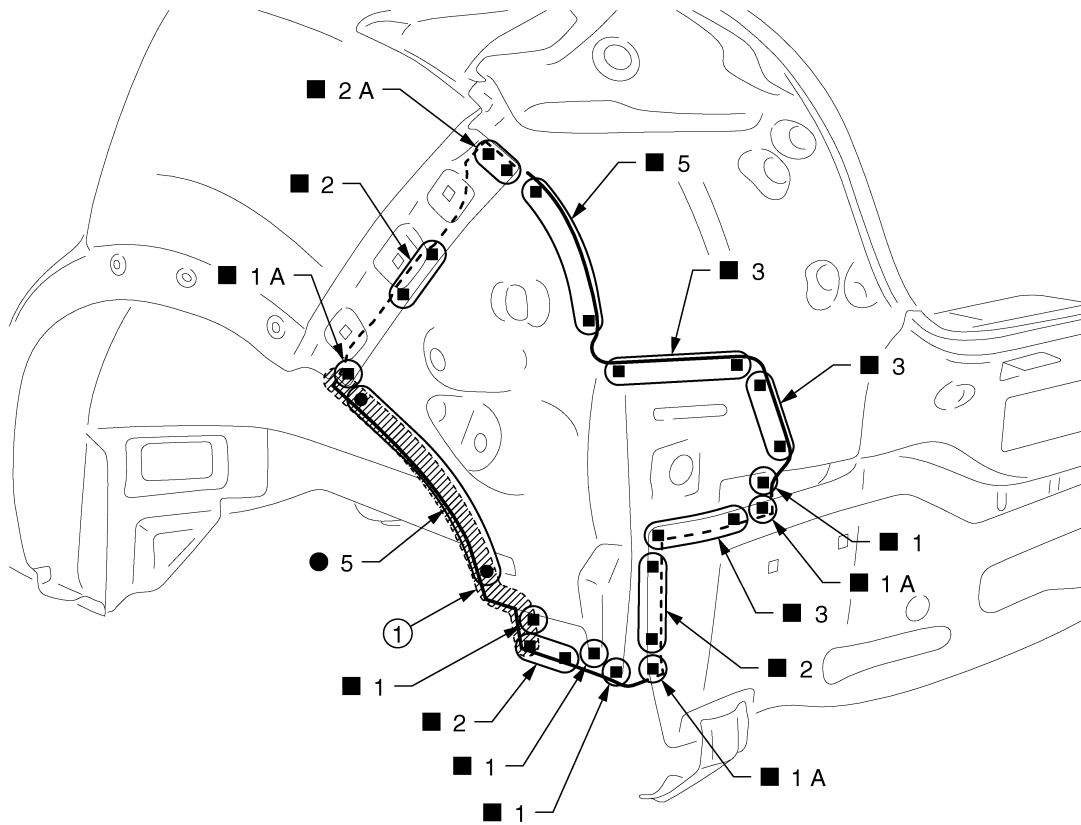

A  
B  
C  
D  
E  
F  
G  
H  
I  
J  
K  
L  
M  
N  
O  
P

BRM

- 1. Body sealing
- Replacement parts
- Rear fender corner (LH)

JSKIA2025ZZ

# REPLACEMENT OPERATIONS

< REMOVAL AND INSTALLATION >

## Rear Fender Extension (AWD Models)

INFOID:00000009750276

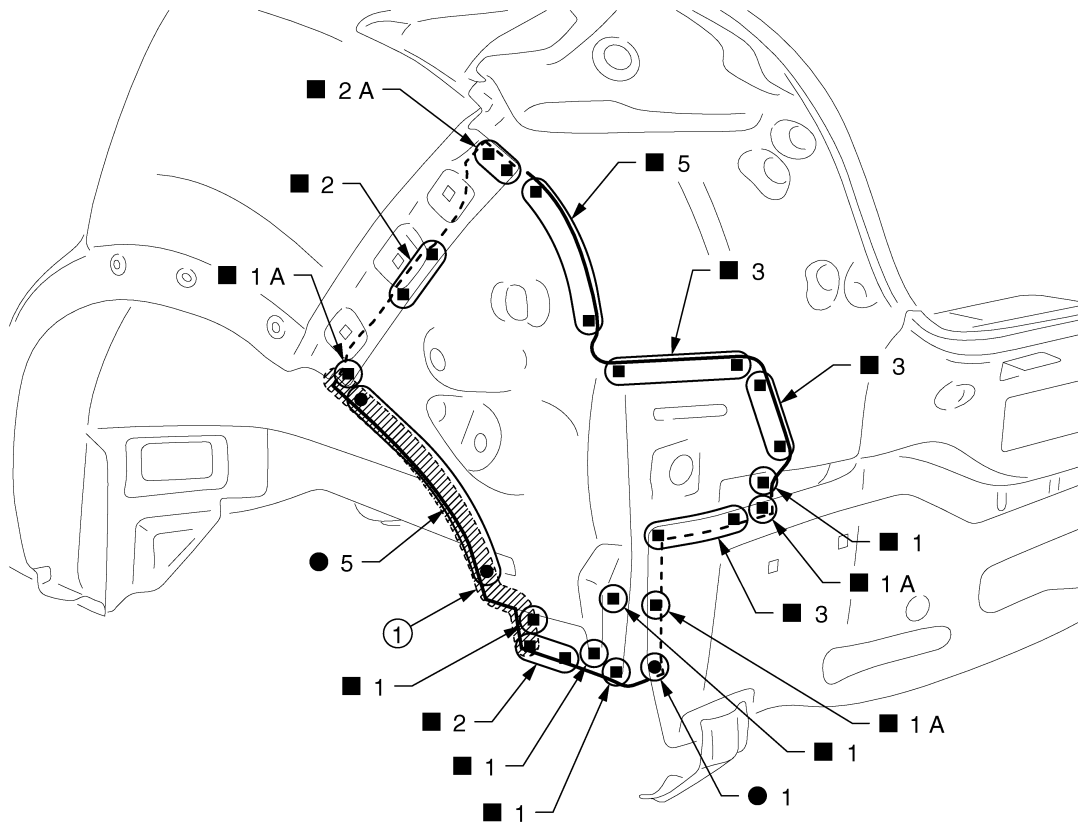

JSKIA2180ZZ

1. Body sealing

Replacement parts

- Rear fender corner (LH)

# REPLACEMENT OPERATIONS

< REMOVAL AND INSTALLATION >

## Rear Panel (2WD Models)

INFOID:000000009750277

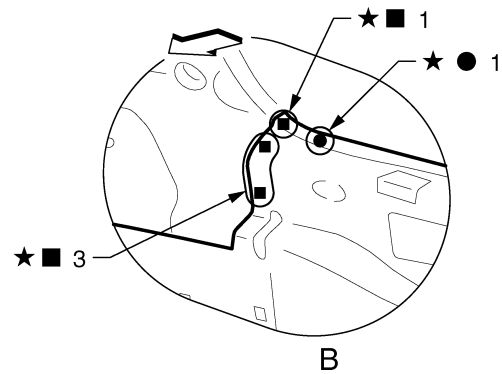
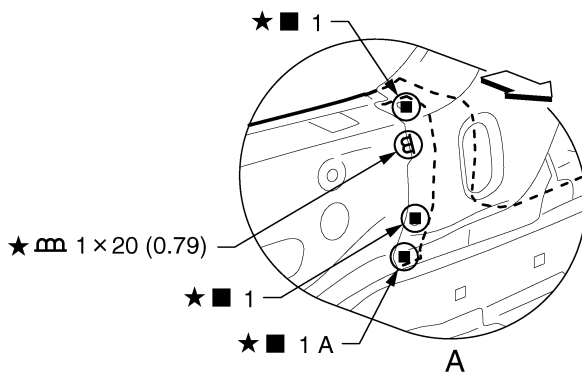
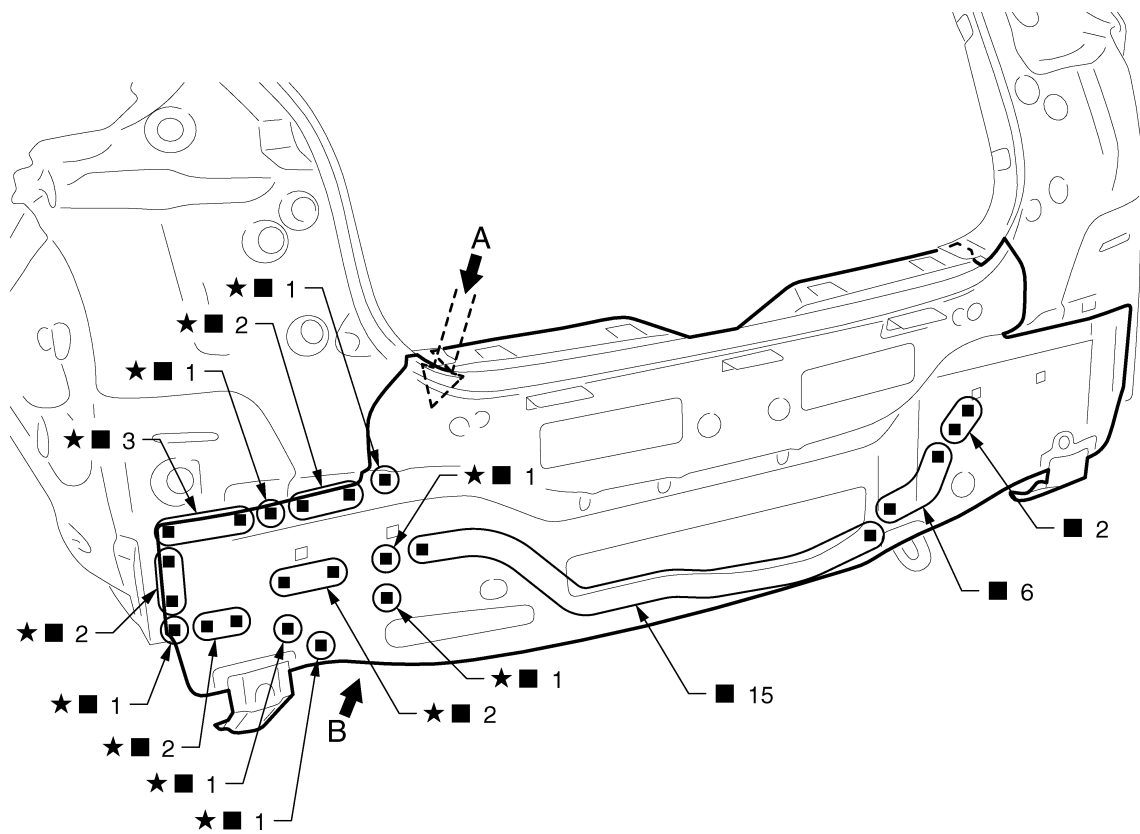

JSKIA2522GB

Unit: mm (in)

↳: Vehicle front

★: Welding method, the number of welding points, and the distance in the figure apply to both side of the vehicle.

Replacement parts

- Upper rear panel

A  
B  
C  
D  
E  
F  
G  
H  
I  
J

BRM

L  
M  
N  
O  
P

# REPLACEMENT OPERATIONS

< REMOVAL AND INSTALLATION >

## Rear Panel (AWD Models)

INFOID:00000009750278

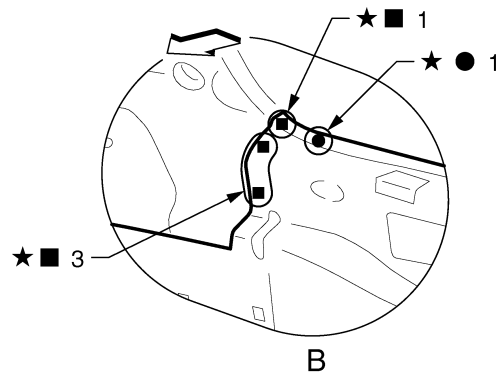
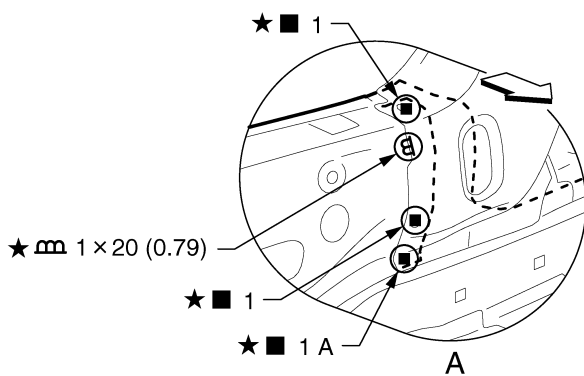
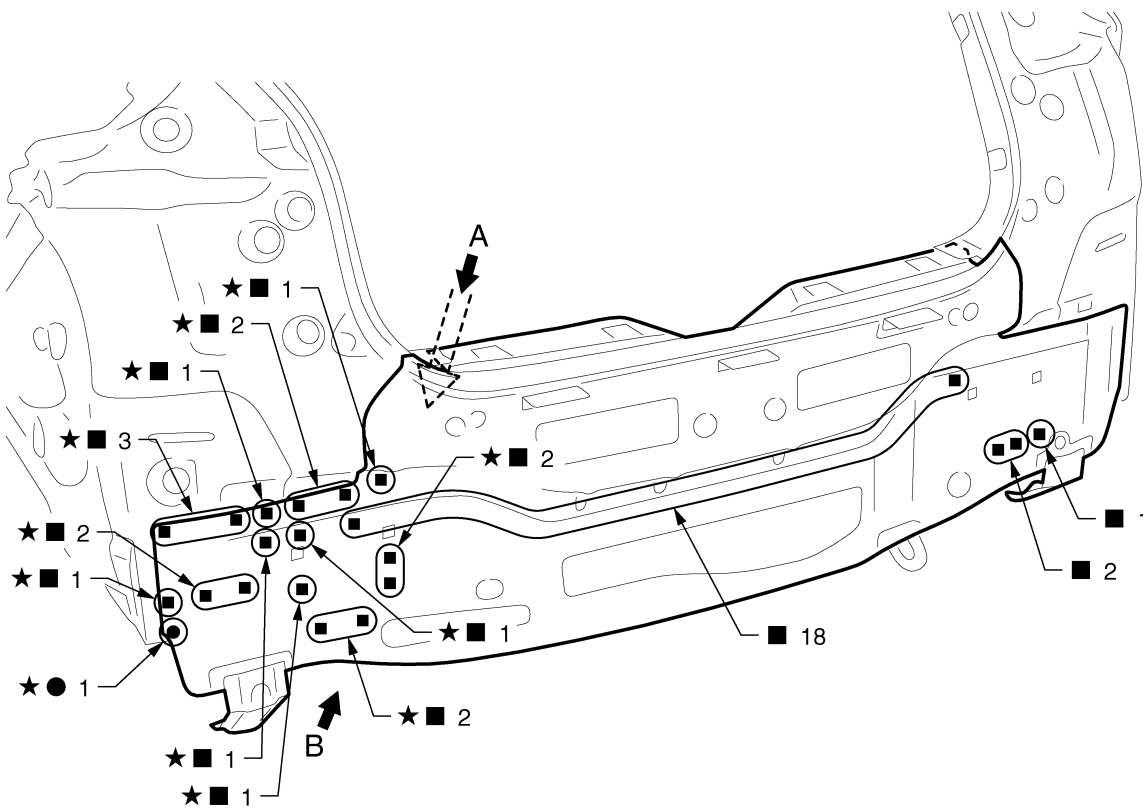

JSKIA2523GB

Unit: mm (in)

↔: Vehicle front

★: Welding method, the number of welding points, and the distance in the figure apply to both side of the vehicle.

Replacement parts

- Upper rear panel

## Rear Floor Rear (2WD Models)

INFOID:000000009750279

Work after rear panel is removed.

# REPLACEMENT OPERATIONS

< REMOVAL AND INSTALLATION >

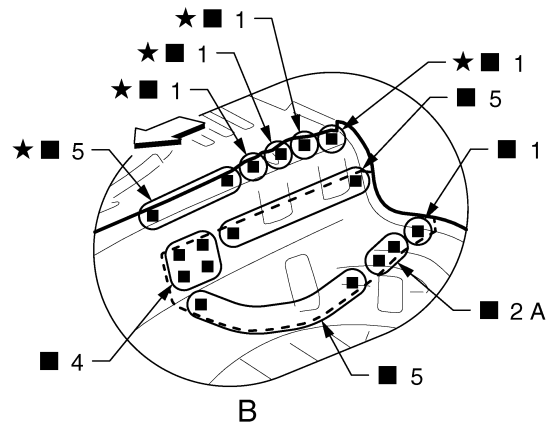
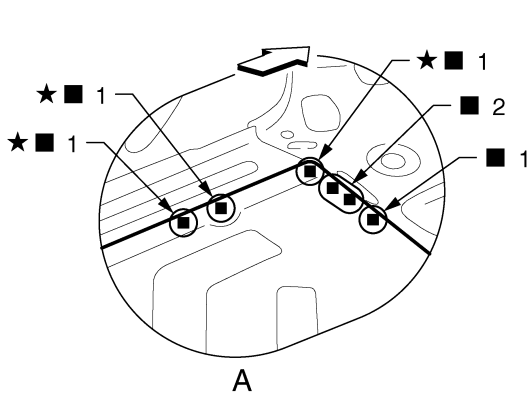
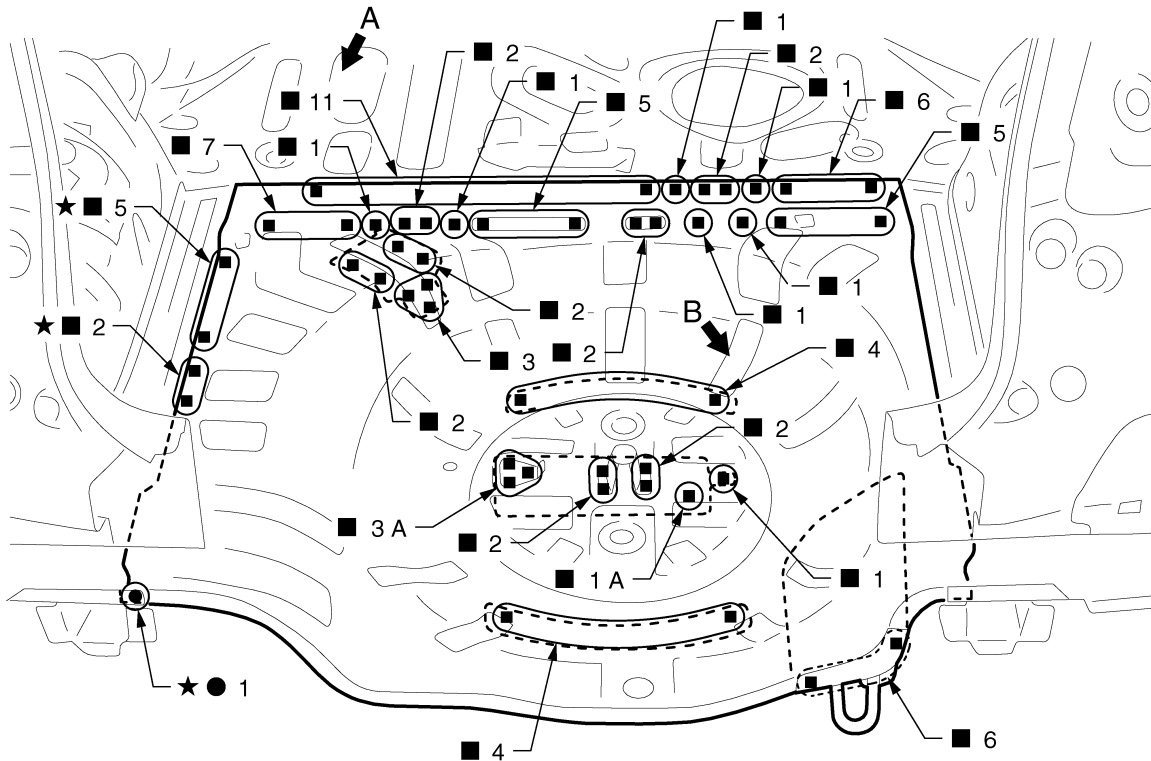

JSKIA2208ZZ

← Vehicle front

★: Welding method and the number of welding points apply to both side of the vehicle.

○: Weld the parts onto the back of the component part.

Replacement parts

- Rear floor rear
- Muffler mounting bracket
- Canister mounting bracket
- Spare tire clamp bracket
- Canister bracket (rear)
- Rear towing hook bracket
- Spare wheel clamp reinforcement

## Rear Floor Rear (AWD Models)

INFOID:000000009750280

Work after rear panel is removed.

A  
B  
C  
D  
E  
F  
G  
H  
I  
J  
K  
L  
M  
N  
O  
P

BRM

# REPLACEMENT OPERATIONS

## < REMOVAL AND INSTALLATION >

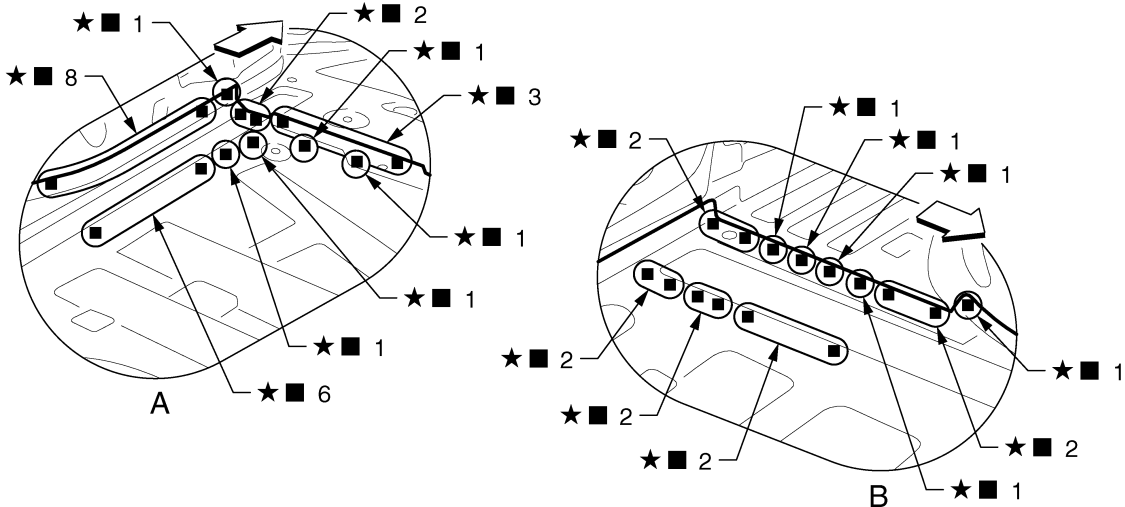
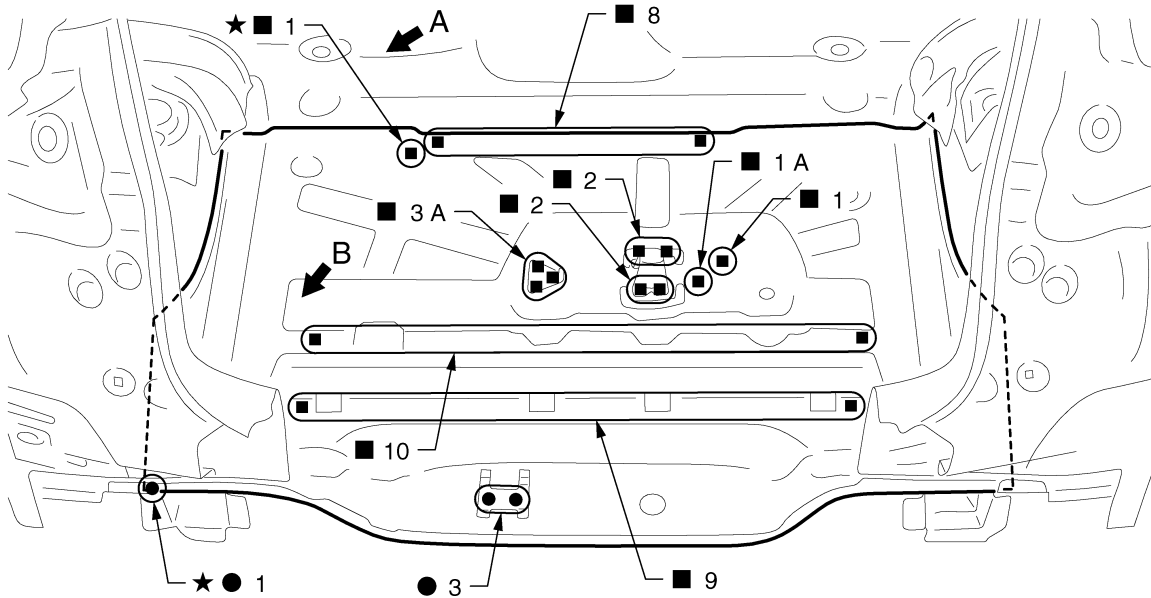

JSKIA2209ZZ

↔: Vehicle front

★: Welding method and the number of welding points apply to both side of the vehicle.

Replacement parts

- Rear floor rear
- Spare tire clamp bracket
- Jack mounting bracket
- Canister bracket
- Spare wheel clamp reinforcement

### Rear Side Member (AWD Models Partial Replacement)

INFOID:000000009750281

Work after rear panel and rear floor rear are removed.



# REPLACEMENT OPERATIONS

< REMOVAL AND INSTALLATION >

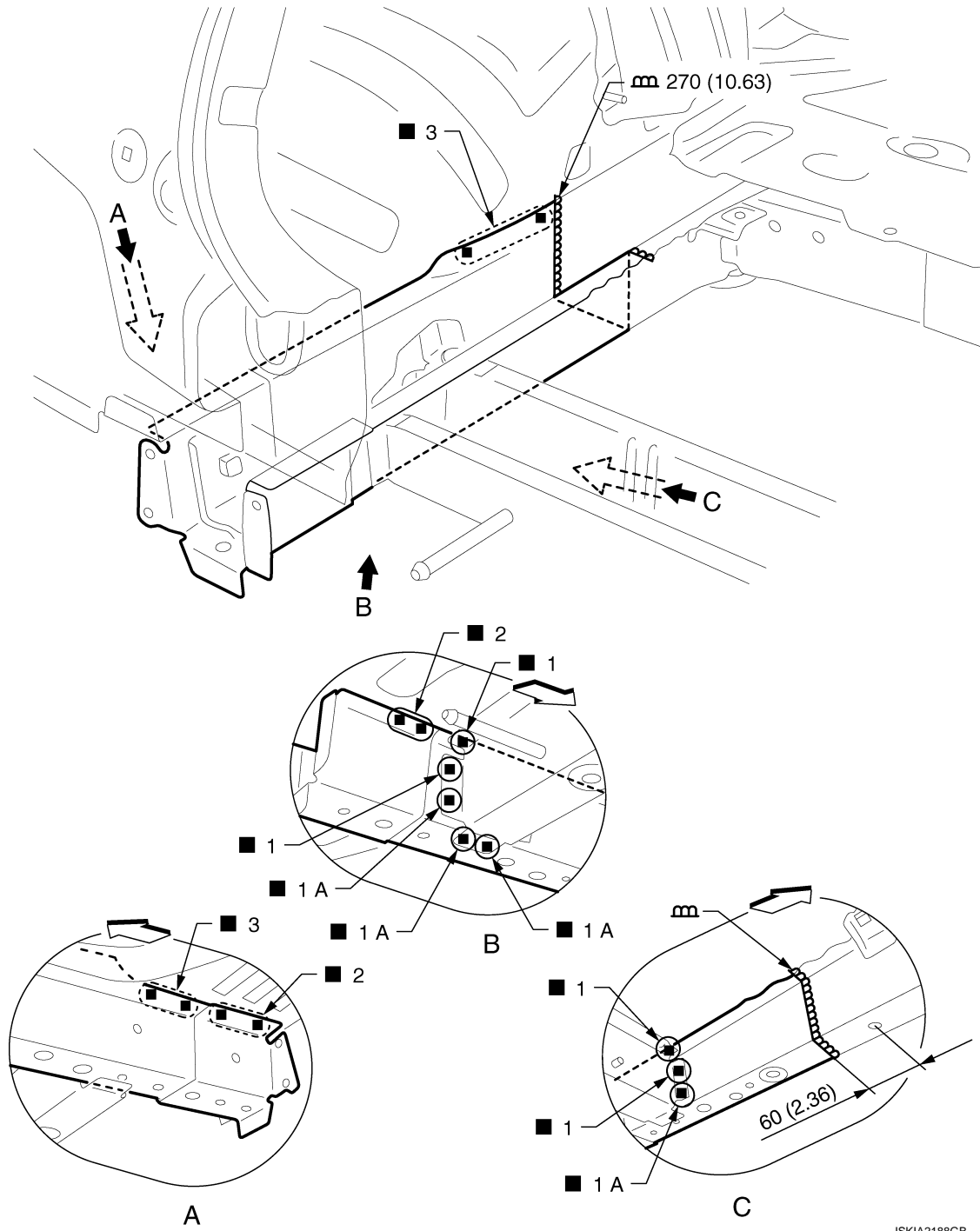

A  
B  
C  
D  
E  
F  
G  
H  
I  
J  
BRM  
L  
M  
N  
O  
P

Unit: mm (in)

⇐: Vehicle front

○: Weld the parts onto the back of the component part.

Replacement parts

- Rear side member (LH)

## Rear Side Member Extension (2WD Models)

INFOID:000000009750282

Work after rear panel is removed.

# REPLACEMENT OPERATIONS

## < REMOVAL AND INSTALLATION >

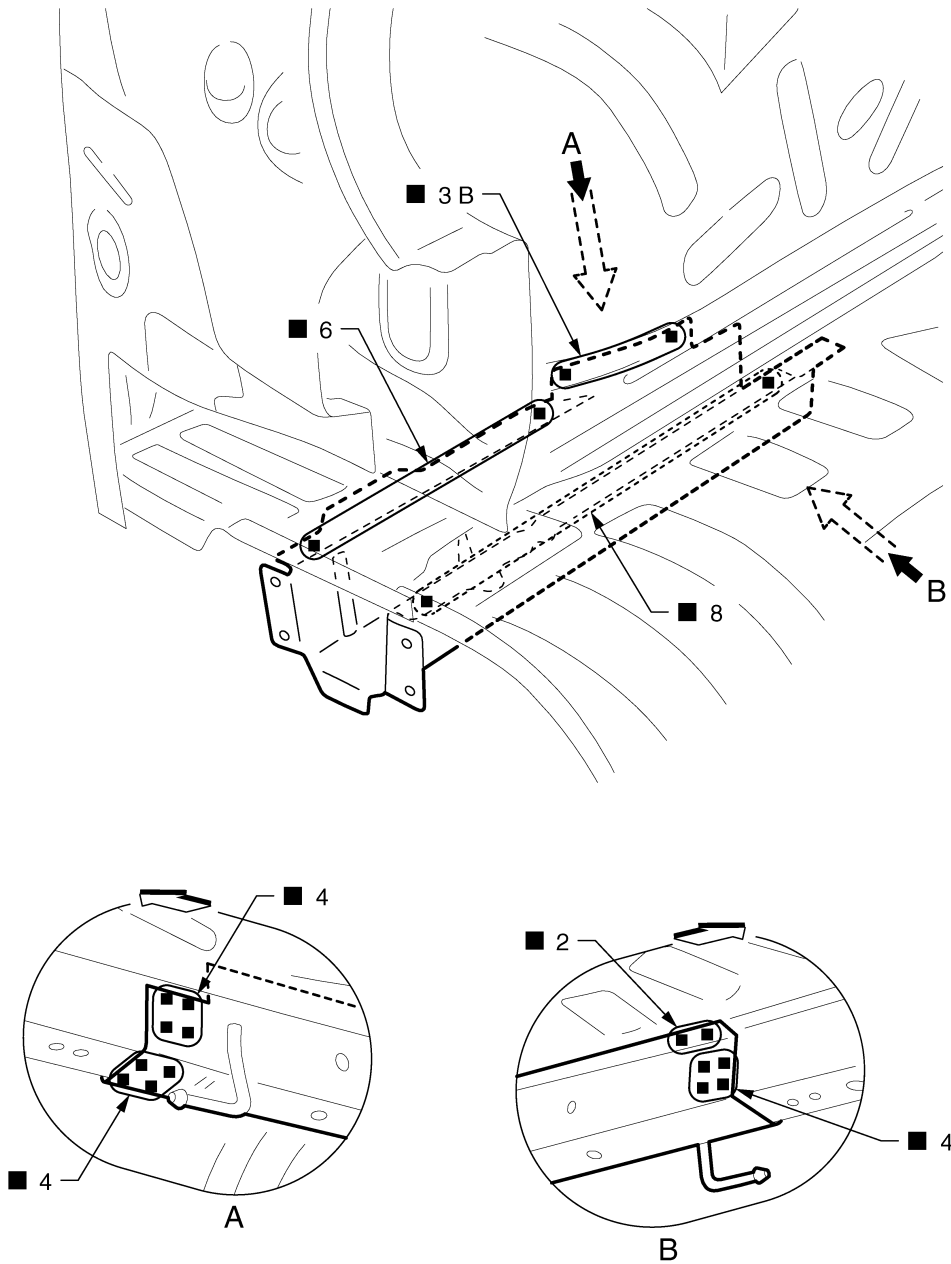

JSKIA2032ZZ

←: Vehicle front

(○): Weld the parts onto the back of the component part.

Replacement parts

- Rear side member extension (LH)

### Rear Side Member Extension (AWD Models)

INFOID:000000009750283

Work after rear panel is removed.

# REPLACEMENT OPERATIONS

## < REMOVAL AND INSTALLATION >

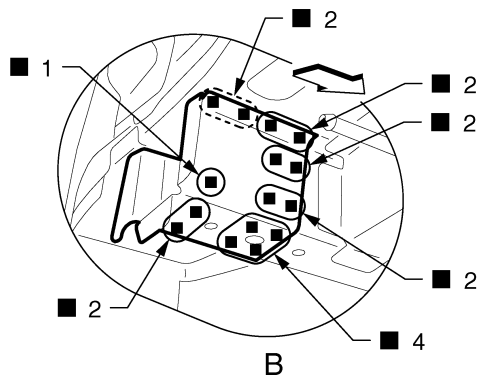
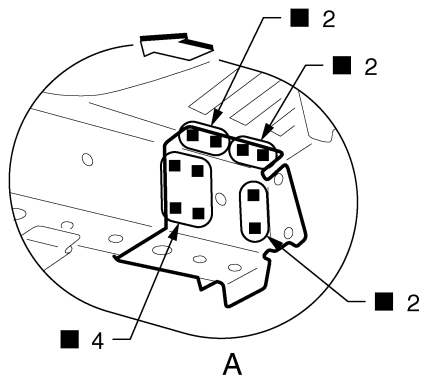
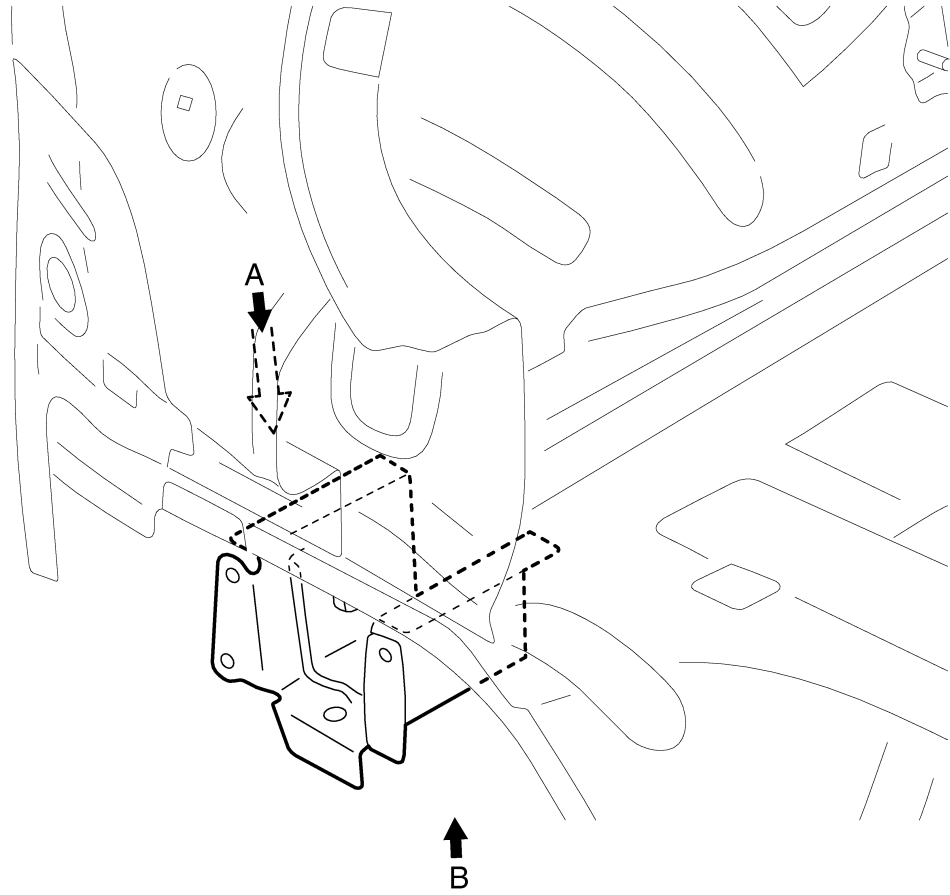

JSKIA2189ZZ

←: Vehicle front

○: Weld the parts onto the back of the component part.

Replacement parts

- Rear side member extension (LH)

A  
B  
C  
D  
E  
F  
G  
H  
I  
J  
BRM  
L  
M  
N  
O  
P

# BODY ALIGNMENT

< SERVICE DATA AND SPECIFICATIONS (SDS)

## SERVICE DATA AND SPECIFICATIONS (SDS)

### BODY ALIGNMENT

#### Body Center Marks

INFOID:000000009750284

A mark is placed on each part of the body to indicate the vehicle center. When repairing the vehicle frame (members, pillars, etc.) damaged by an accident which it enables more accurate and effective repair by using these marks together with body alignment specifications.

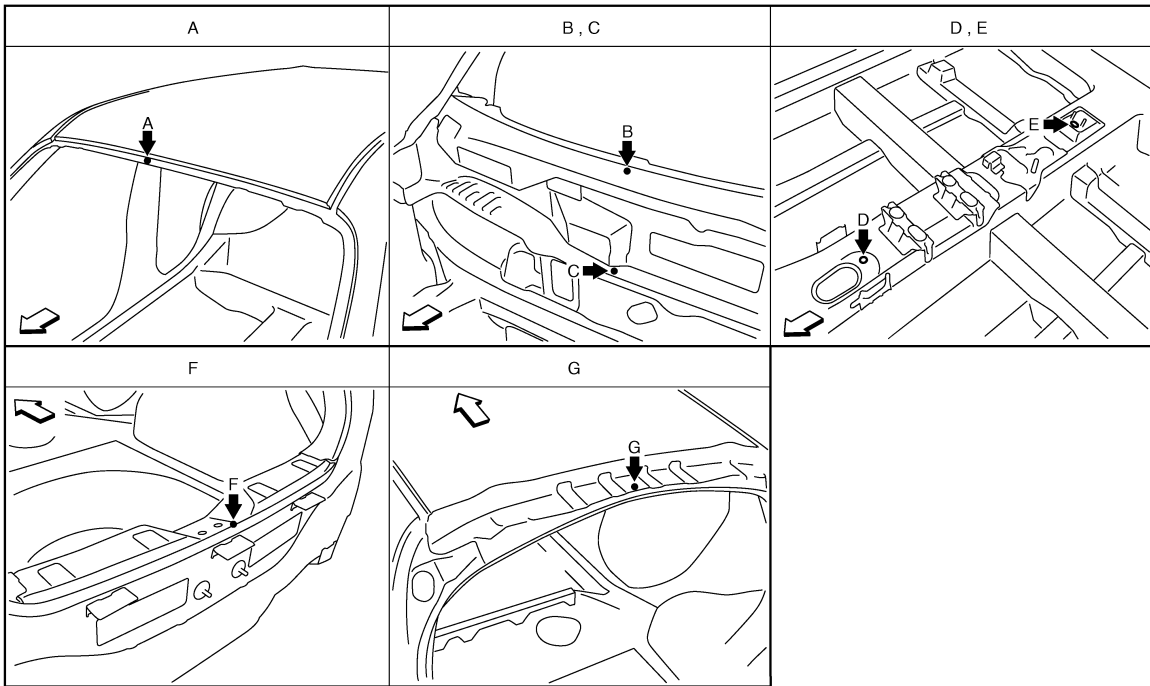
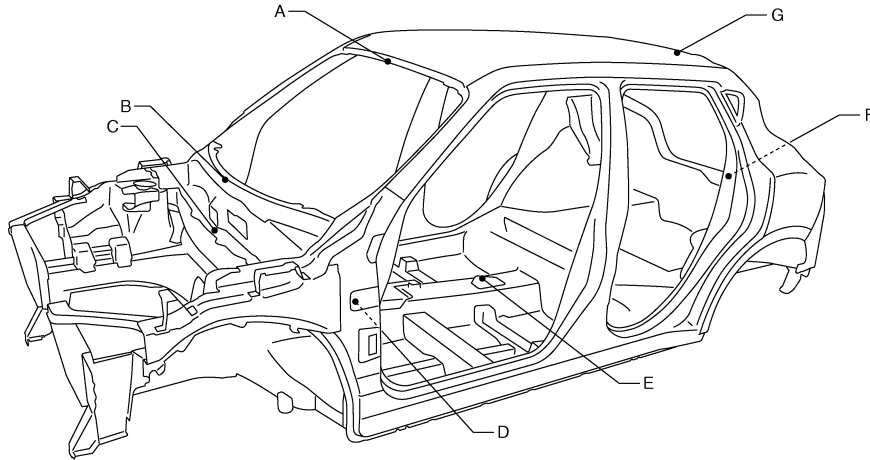

JSKIA2144ZZ

↶: Vehicle front

Unit: mm (in)

Points	Portion	Marks
A	Front roof	Embossment
B	Cowl top	Embossment
C	Upper dash	Embossment
D	Trans control reinforcement	Hole $\phi$ 16 (0.63)

# BODY ALIGNMENT

## < SERVICE DATA AND SPECIFICATIONS (SDS)

Points	Portion	Marks
E	Parking brake reinforcement	Hole $\phi 12$ (0.47)
F	Rear panel	Indent
G	Rear roof	Embossment

### Description

INFOID:000000009750285

- All dimensions indicated in the figures are actual.
- When using a tracking gauge, adjust both pointers to equal length. Then check the pointers and gauge itself to make sure there is no free play.
- When a measuring tape is used, check to be sure there is no elongation, twisting or bending.
- Measurements should be taken at the center of the mounting holes.
- An asterisk (\*) following the value at the measuring point indicates that the measuring point on the other side is symmetrically the same value.
- The coordinates of the measurement points are the distances measured from the standard line of "X", "Y" and "Z".
- "Z": Imaginary base line [200 mm (7.87 in) below datum line ("0Z" at design plan)]

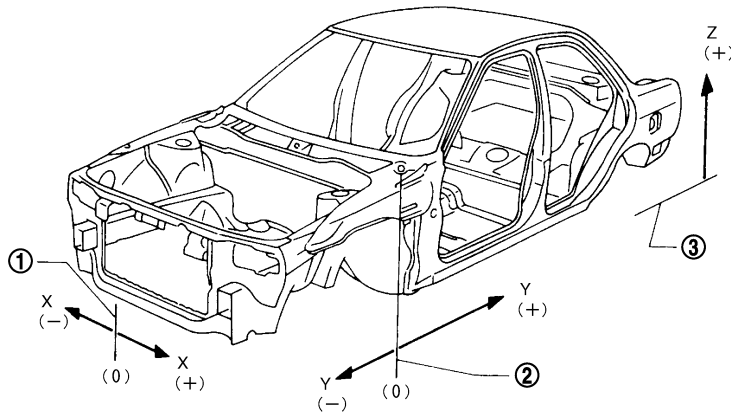

JSKIA0073GB

1. Vehicle center

2. Front axle center

3. Imaginary base line

### Engine Compartment

INFOID:000000009750286

#### MEASUREMENT

Dimensions marked with "\*" indicate symmetrically identical dimensions on both the right and left hand of the vehicle.

# BODY ALIGNMENT

< SERVICE DATA AND SPECIFICATIONS (SDS)

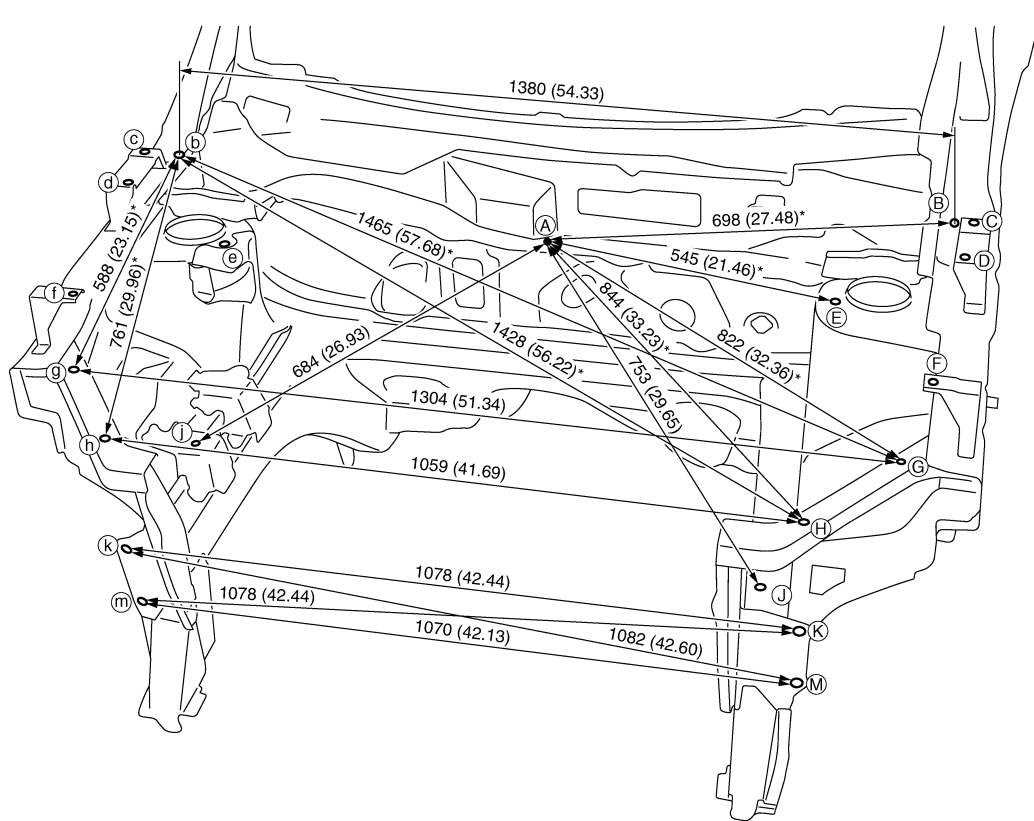

JSKIA2151GB

Unit: mm (in)

«The others»

Unit: mm (in)

Point	Dimension	Memo	Point	Dimension	Memo	Point	Dimension	Memo	Point	Dimension	Memo
A - C	729 (28.70)*		B - E	298 (11.73)*		D - d	1429 (56.26)		G - h	1192 (46.93)*	
A - D	729 (28.70)*		B - e	1233 (48.54)*		E - e	1037 (40.83)		J - j	958 (37.72)	
A - F	798 (31.42)*		C - c	1441 (56.73)		F - f	1366 (53.78)				

## MEASUREMENT POINTS

# BODY ALIGNMENT

## < SERVICE DATA AND SPECIFICATIONS (SDS)

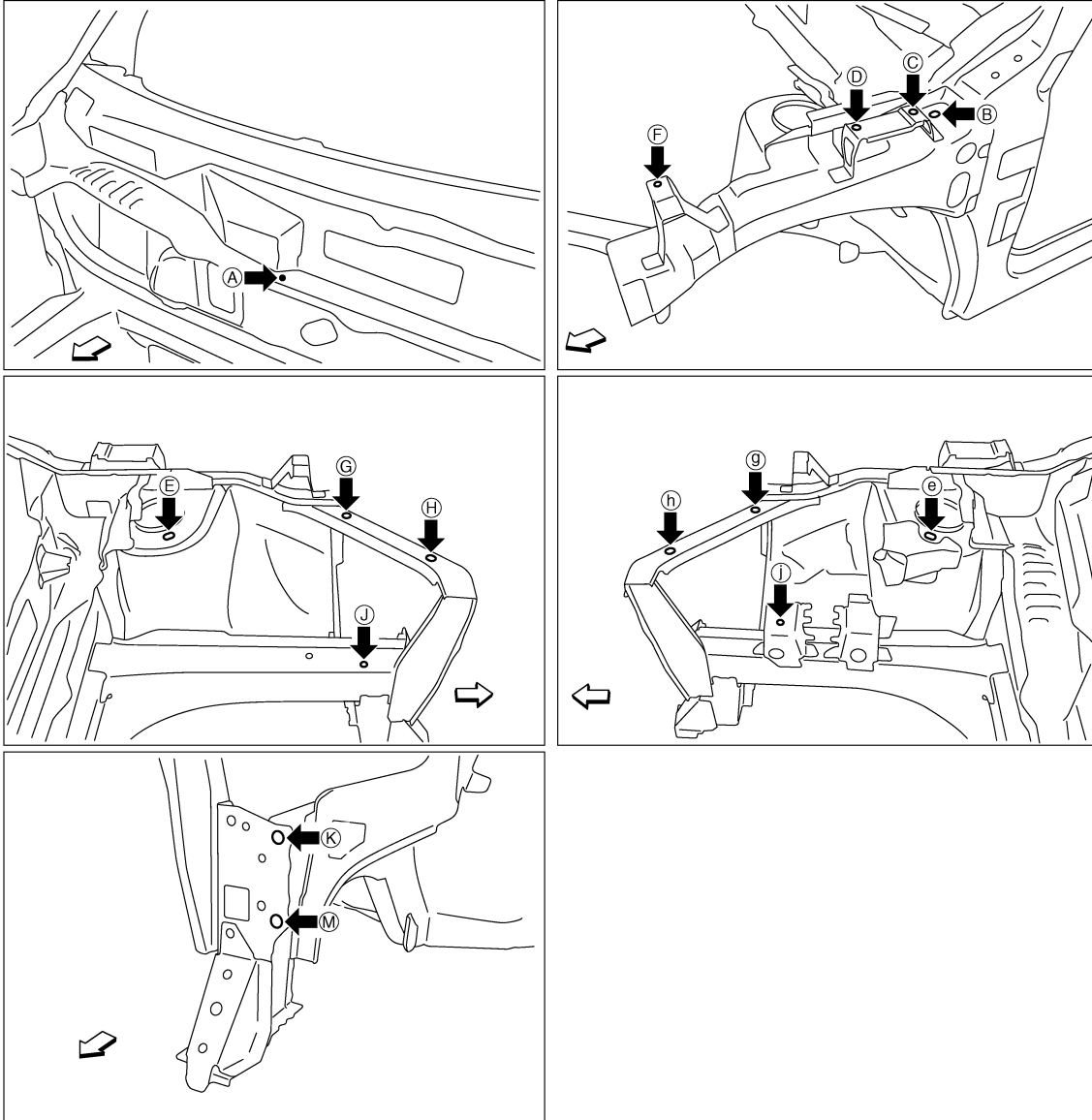

JSKIA2152ZZ

←: Vehicle front

Unit: mm (in)

Point	Material	Point	Material
A	Upper dash positioning mark of center positioning mark	G, g, H, h	Upper radiator core support hole center G, g: $\phi 12$ (0.47) H, h: $14 \times 12$ (0.55 $\times$ 0.47)
B, b	Hoodedge reinforcement hole center $14 \times 10$ (0.55 $\times$ 0.39)	J	Front side member hole center $\phi 7$ (0.28)
C, c, F, f	Front fender installing hole center $\phi 7$ (0.28)	j	Engine mounting bracket hole center $\phi 11$ (0.43)
D, d	Front combination lamp installing hole center $\phi 7$ (0.28)	K, k, M, m	Front bumper stay installing hole center $\phi 15$ (0.59)
E, e	Front strut installing hole center $16 \times 10$ (0.63 $\times$ 0.39)		

# BODY ALIGNMENT

< SERVICE DATA AND SPECIFICATIONS (SDS)

## Underbody (2WD Models)

INFOID:000000009750287

### MEASUREMENT

Dimensions marked with "\*" indicate symmetrically identical dimensions on both the right and left hand of the vehicle.

The following figure shows a bottom view and a side view of the vehicle.

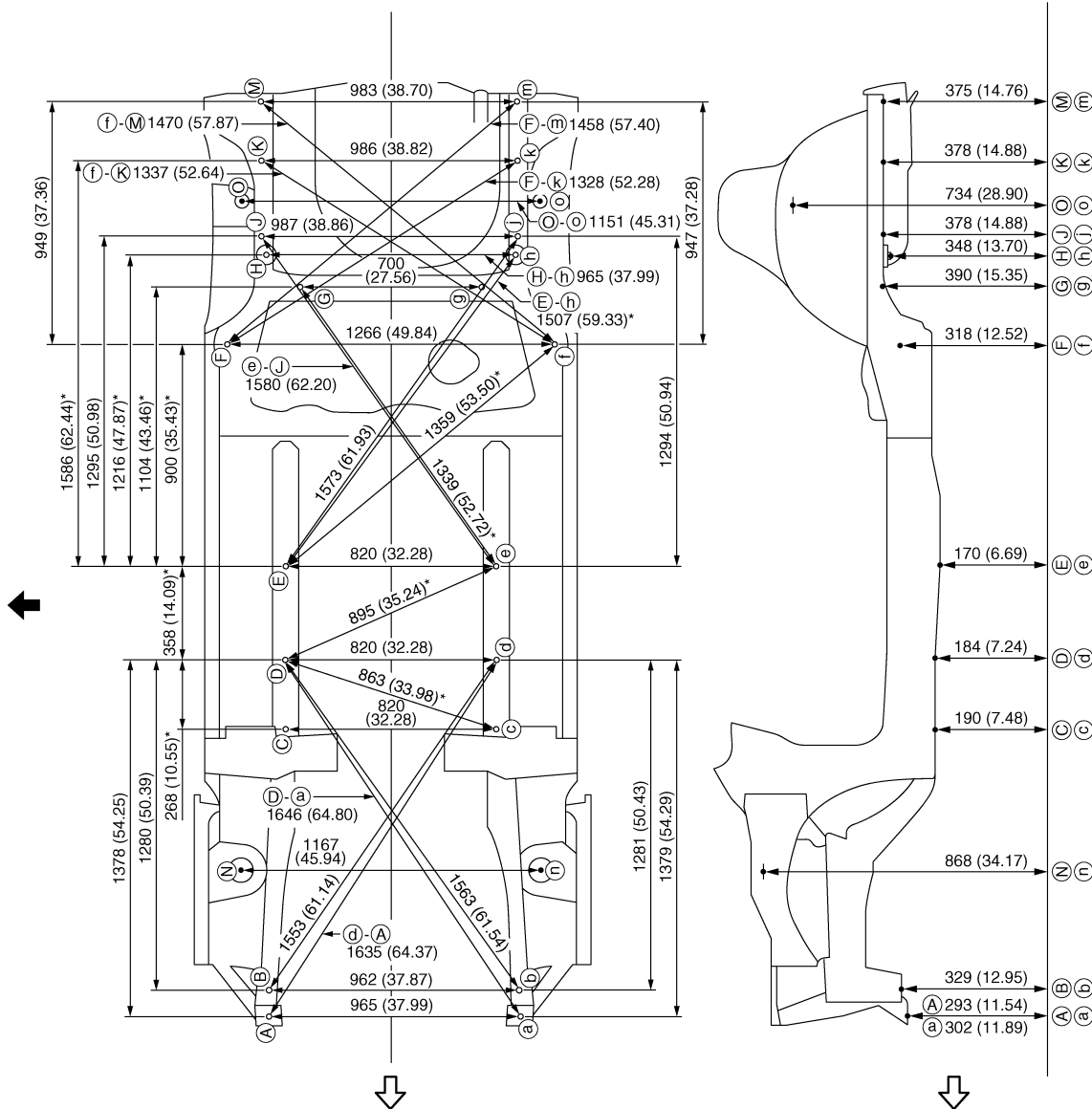

JSKIA1991GB



# BODY ALIGNMENT

## < SERVICE DATA AND SPECIFICATIONS (SDS)

Unit: mm (in)

↔: Vehicle front

←: Vehicle left side

### MEASUREMENT POINTS

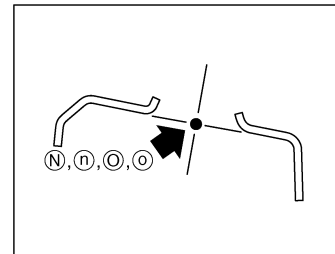
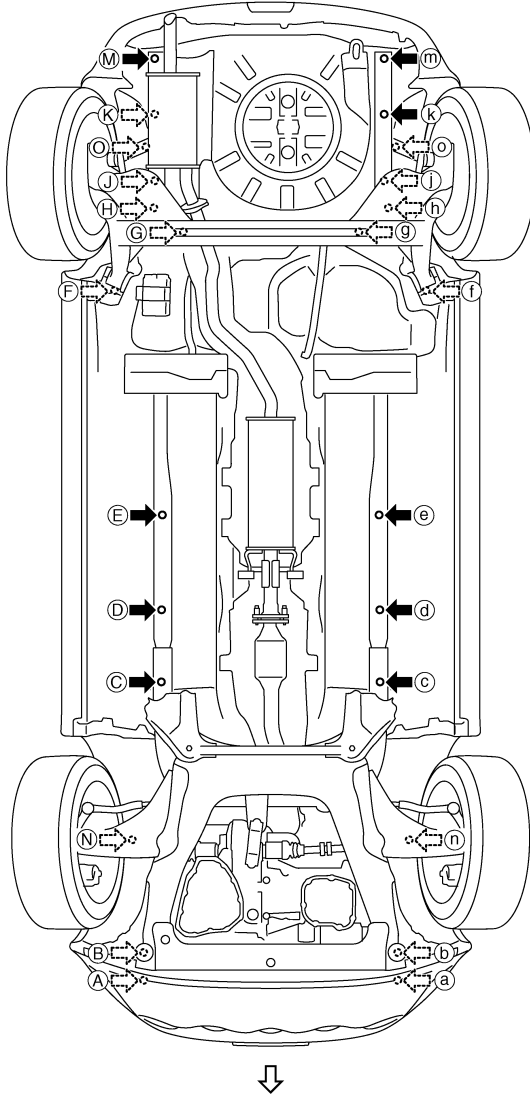

JSKIA2153ZZ

↔: Vehicle front

Unit: mm (in)

Points	Coordinates			Remarks	Points	Coordinates			Remarks
	X	Y	Z			X	Y	Z	
A	473.5 (18.642)	-557.0 (-21.929)	293.0 (11.535)	Hole $\phi$ 11 (0.43)	H, h	$\pm$ 482.3 ( $\pm$ 18.988)	2374.2 (93.472)	348.3 (13.713)	Hole $\phi$ 12 (0.47)
a	-491.0 (-19.331)	-557.0 (-21.929)	301.9 (11.886)	Hole $\phi$ 11 (0.43)	J	499.5 (19.665)	2448.0 (96.378)	378.0 (14.882)	Hole $\phi$ 21 (0.83)
B	472.4 (18.598)	-455.0 (-17.913)	328.9 (12.949)	Hole $\phi$ 18 (0.71)	j	-487.5 (-19.193)	2448.0 (96.378)	378.0 (14.882)	Hole $\phi$ 21 (0.83)

A  
B  
C  
D  
E  
F  
G  
H  
I  
J  
K  
L  
M  
N  
O  
P

BRM

# BODY ALIGNMENT

## < SERVICE DATA AND SPECIFICATIONS (SDS)

Points	Coordinates			Remarks	Points	Coordinates			Remarks
	X	Y	Z			X	Y	Z	
b	-489.7 (-19.279)	-455.0 (-17.913)	328.9 (12.949)	Hole $\phi$ 18 (0.71)	K	498.0 (19.606)	2743.0 (107.992)	378.0 (14.882)	Hole 17×16 (0.67×0.63)
C, c	$\pm$ 410.0 ( $\pm$ 16.142)	547.0 (21.535)	190.2 (7.488)	Hole $\phi$ 16 (0.63)	k	-487.5 (-19.193)	2743.0 (107.992)	378.0 (14.882)	Hole 17×16 (0.67×0.63)
D, d	$\pm$ 410.0 ( $\pm$ 16.142)	815.0 (32.087)	184.0 (7.244)	Hole $\phi$ 12 (0.47)	M	498.0 (19.606)	2970.0 (116.929)	375.4 (14.779)	Hole $\phi$ 16 (0.63)
E, e	$\pm$ 410.0 ( $\pm$ 16.142)	1173.0 (46.181)	170.1 (6.697)	Hole 14×2 (0.55×0.47)	m	-485.1 (-19.098)	2965.8 (116.764)	375.4 (14.779)	Hole $\phi$ 16 (0.63)
F, f	$\pm$ 633.0 ( $\pm$ 24.921)	2032.3 (80.012)	318.0 (12.520)	Hole $\phi$ 16 (0.63)	N, n	$\pm$ 583.6 ( $\pm$ 22.976)	6.6 (0.261)	868.2 (34.181)	Hole $\phi$ 98 (3.86)
G, g	$\pm$ 350.0 ( $\pm$ 13.780)	2253.0 (88.701)	390.4 (15.370)	Hole $\square$ 16 (0.63)	O, o	$\pm$ 575.4 ( $\pm$ 22.653)	2569.2 (101.149)	734.4 (28.913)	Hole $\phi$ 20 (0.79)

### Underbody (AWD Models)

INFOID:000000009750288

### MEASUREMENT

Dimensions marked with "\*" indicate symmetrically identical dimensions on both the right and left hand of the vehicle.

The following figure shows a bottom view and a side view of the vehicle.

# BODY ALIGNMENT

< SERVICE DATA AND SPECIFICATIONS (SDS)

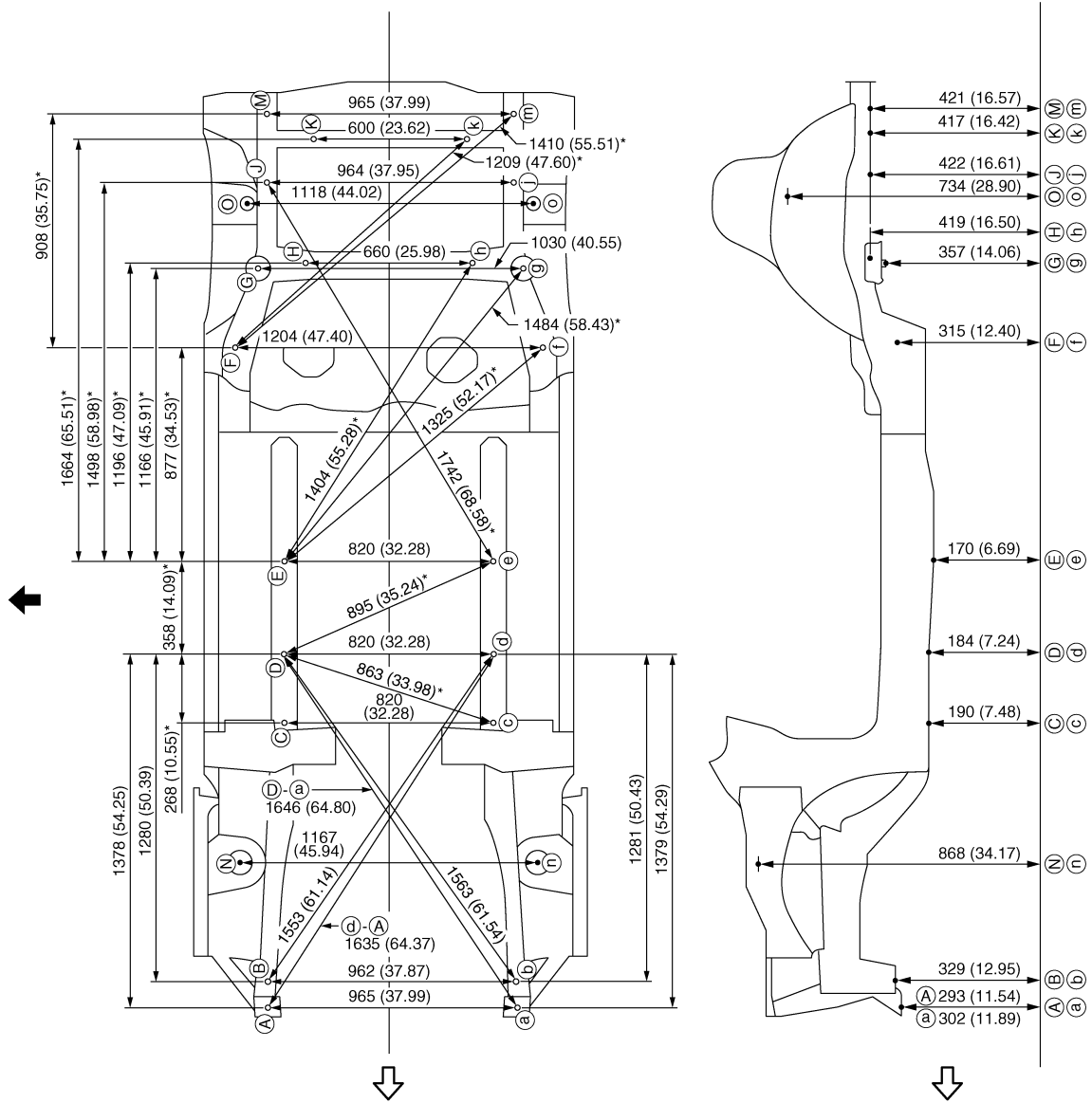

A  
B  
C  
D  
E  
F  
G  
H  
I  
J  
K  
L  
M  
N  
O  
P

BRM

Unit: mm (in)  
 ↗ Vehicle front  
 ← Vehicle left side

## MEASUREMENT POINTS

# BODY ALIGNMENT

< SERVICE DATA AND SPECIFICATIONS (SDS)

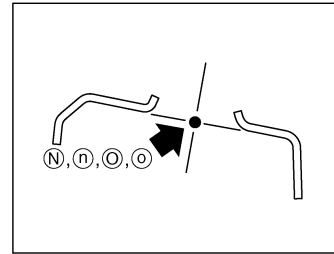
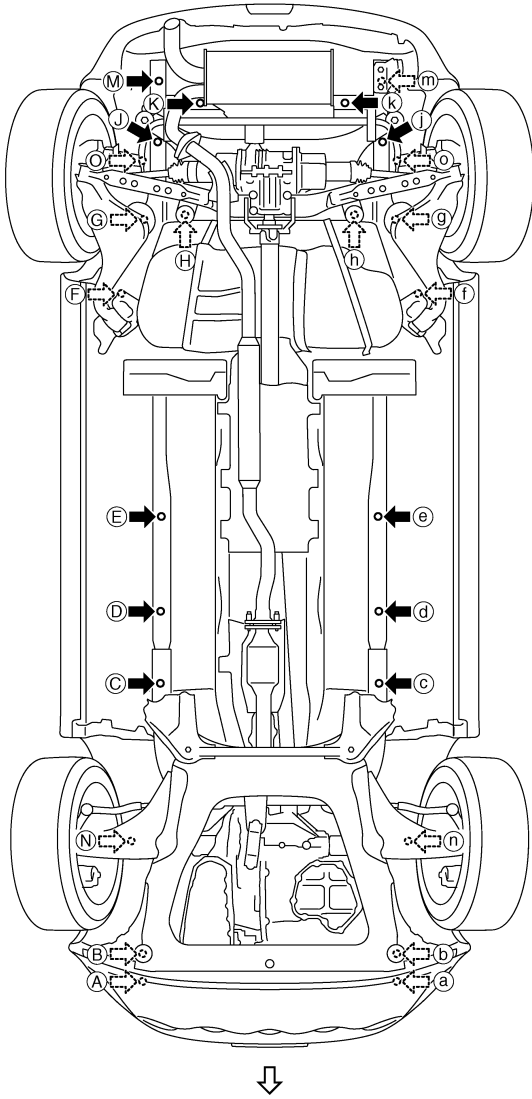

JSKIA2155ZZ

↔ Vehicle front

Unit: mm (in)

Points	Coordinates			Remarks	Points	Coordinates			Remarks
	X	Y	Z			X	Y	Z	
A	473.5 (18.642)	-557.0 (-21.929)	293.0 (11.535)	Hole $\phi$ 11 (0.43)	G, g	$\pm$ 515.1 ( $\pm$ 20.279)	2318.6 (91.283)	357.2 (14.063)	Hole $\phi$ 12 (0.47)
a	-491.0 (-19.331)	-557.0 (-21.929)	301.9 (11.886)	Hole $\phi$ 11 (0.43)	H, h	$\pm$ 330.0 ( $\pm$ 12.992)	2339.7 (92.114)	419.0 (16.496)	Hole 33 $\times$ 30 (1.30 $\times$ 1.18)
B	472.4 (18.598)	-455.0 (-17.913)	328.9 (12.949)	Hole $\phi$ 18 (0.71)	J, j	$\pm$ 482.0 ( $\pm$ 18.976)	2648.0 (104.252)	422.2 (16.622)	Hole 20 $\times$ 6 (0.79 $\times$ 0.63)
b	-489.7 (-19.279)	-455.0 (-17.913)	328.9 (12.949)	Hole $\phi$ 18 (0.71)	K, k	$\pm$ 300.0 ( $\pm$ 11.811)	2815.0 (110.827)	417.2 (16.425)	Hole 18 $\times$ 6 (0.71 $\times$ 0.63)
C, c	$\pm$ 410.0 ( $\pm$ 16.142)	547.0 (21.535)	190.2 (7.488)	Hole $\phi$ 16 (0.63)	M, m	$\pm$ 482.7 ( $\pm$ 19.004)	2910.5 (114.586)	421.4 (16.591)	Hole $\phi$ 23 (0.91)
D, d	$\pm$ 410.0 ( $\pm$ 16.142)	815.0 (32.087)	184.0 (7.244)	Hole $\phi$ 12 (0.47)	N, n	$\pm$ 583.6 ( $\pm$ 22.976)	6.6 (0.261)	868.2 (34.181)	Hole $\phi$ 98 (3.86)

# BODY ALIGNMENT

## < SERVICE DATA AND SPECIFICATIONS (SDS)

Points	Coordinates			Remarks	Points	Coordinates			Remarks
	X	Y	Z			X	Y	Z	
E, e	±410.0 (±16.142)	1173.0 (46.181)	170.1 (6.697)	Hole 14×2 (0.55×0.47)	O, o	±558.8 (±22.000)	2568.4 (101.118)	734.4 (28.913)	Hole φ20 (0.79)
F, f	±601.8 (±23.693)	2016.4 (79.386)	315.0 (12.402)	Hole φ15 (0.59)					

### Passenger Compartment

INFOID:000000009750289

### MEASUREMENT

Dimensions marked with "\*" indicate symmetrically identical dimensions on both the right and left hand of the vehicle.

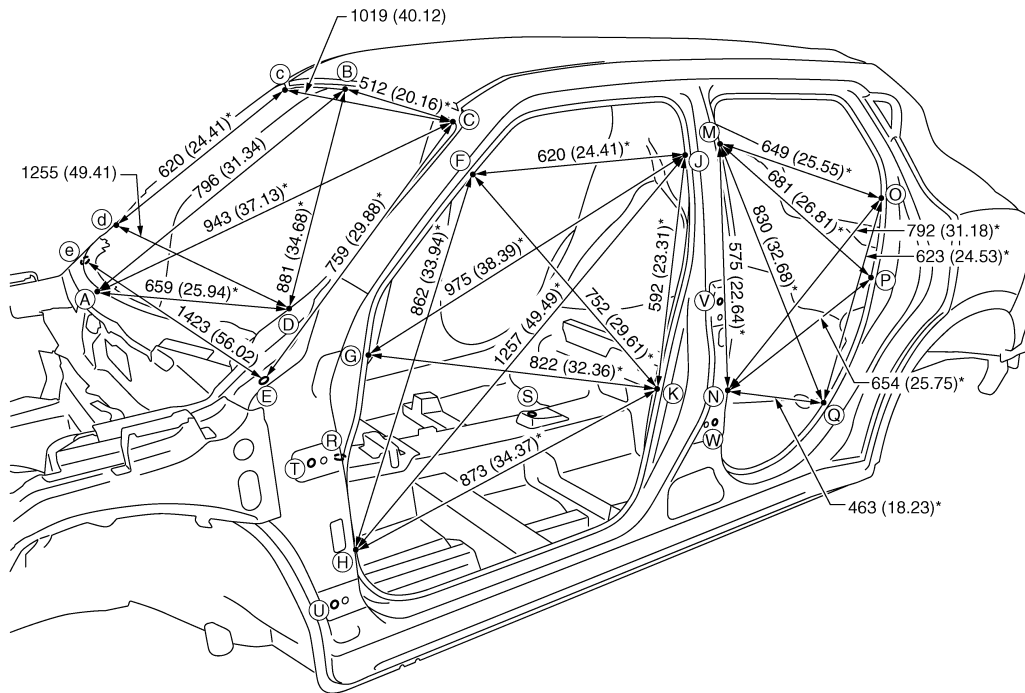

JSKIA1996GB

Unit: mm (in)

«The others»

BRM

# BODY ALIGNMENT

## < SERVICE DATA AND SPECIFICATIONS (SDS)

Unit: mm (in)

Point	Dimension	Memo	Point	Dimension	Memo	Point	Dimension	Memo	Point	Dimension	Memo
A - E	724 (28.50)*		H - h	1406 (55.35)		N - n	1423 (56.02)		R - J	1394 (54.88)*	
B - E	1028 (40.47)*		H - j	1829 (72.01)*		N - o	1585 (62.40)*		R - K	1072 (42.20)*	
C - d	1290 (50.79)*		H - k	1663 (65.47)*		N - p	1554 (61.18)*		S - M	1094 (43.07)*	
C - e	1423 (56.02)*		J - j	1257 (49.49)		N - q	1506 (59.29)*		S - N	786 (30.94)*	
F - f	1222 (48.11)		J - k	1463 (57.60)*		O - o	1326 (52.20)		S - O	1248 (49.13)*	
F - h	1569 (61.77)*		K - k	1425 (56.10)		O - q	1518 (59.76)*		S - P	1126 (44.33)*	
F - j	1386 (54.57)*		M - m	1248 (49.13)		P - p	1397 (55.00)		S - Q	905 (35.63)*	
F - k	1519 (59.80)*		M - n	1451 (57.13)*		Q - q	1444 (56.85)		T - V	1128 (44.41)*	
G - g	1359 (53.50)		M - o	1441 (56.73)*		R - F	1104 (43.46)*		T - W	1105 (43.50)*	
G - j	1630 (64.17)*		M - p	1486 (58.50)*		R - G	885 (34.84)*		U - V	1204 (47.40)*	
G - k	1616 (63.62)*		M - q	1578 (62.13)*		R - H	720 (28.35)*		U - W	1091 (42.95)*	

## MEASUREMENT POINTS

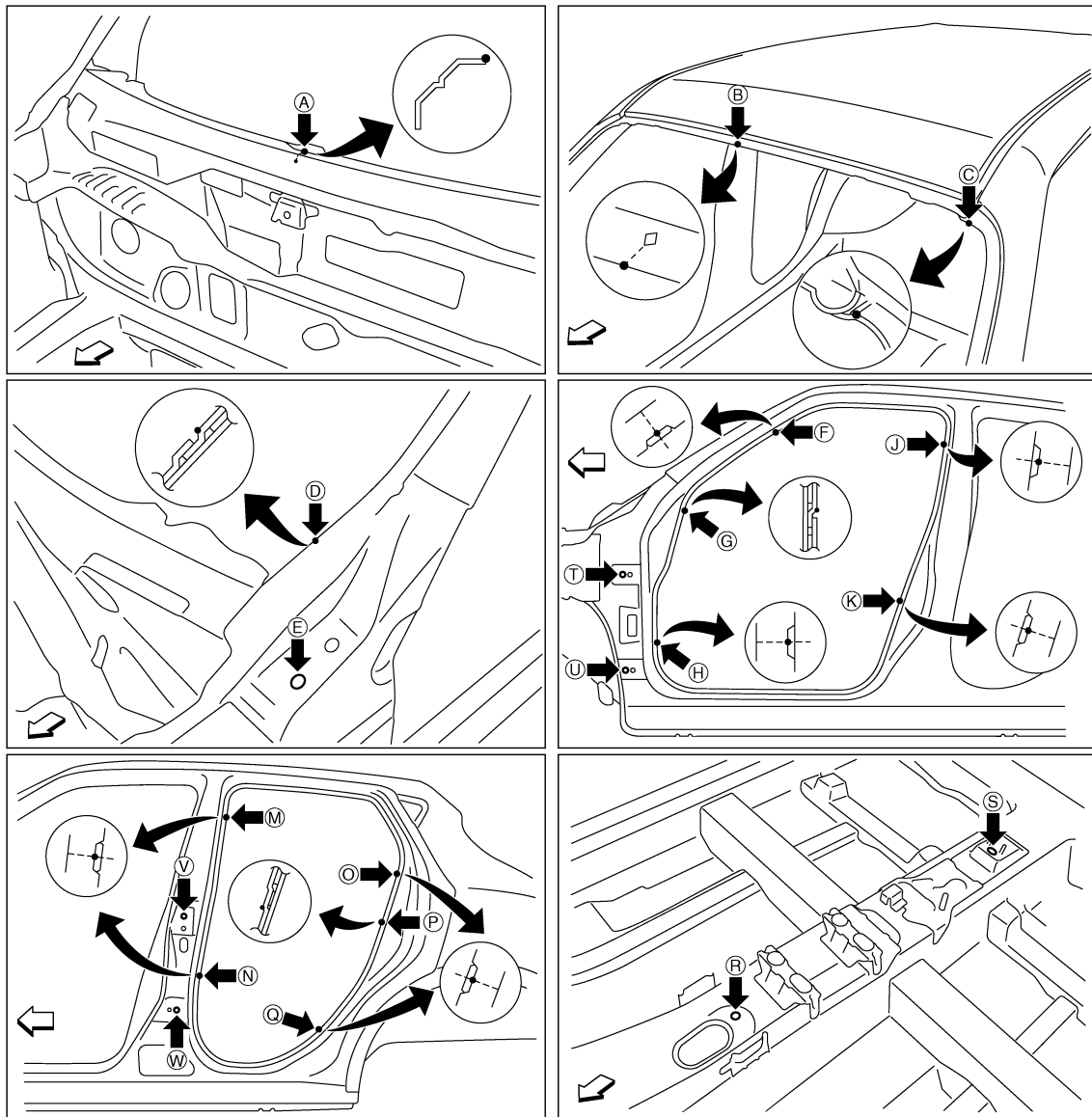

JSKIA1997ZZ

# BODY ALIGNMENT

## < SERVICE DATA AND SPECIFICATIONS (SDS)

↶: Vehicle front

Unit: mm (in)

Point	Material	Point	Material
A	Cowl top flange end of center positioning mark	J, j, K, k, M, M, N, n	Center pillar indent
B	Roof flange end of center positioning mark	O, o, Q, q	Rear fender indent
C, c	Outer side body joggle	P, p	Outer rear wheelhouse joggle
D, d, G, g	Upper inner front pillar joggle	R	Trans control reinforcement hole center of center positioning mark $\phi 16$ (0.63)
E, e	Hood hinge installing hole center $\phi 12$ (0.47)	S	Parking brake reinforcement hole center of center positioning mark $\phi 12$ (0.47)
F, f, H, h	Front pillar indent	T, t, U, u, V, v, W, w	Door hinge installing hole center T, t, U, u, W, w: $\phi 12$ (0.47) V, v: $\phi 9$ (0.35)

### Rear Body

INFOID:000000009750290

### MEASUREMENT

Dimensions marked with "\*" indicate symmetrically identical dimensions on both the right and left hand of the vehicle.

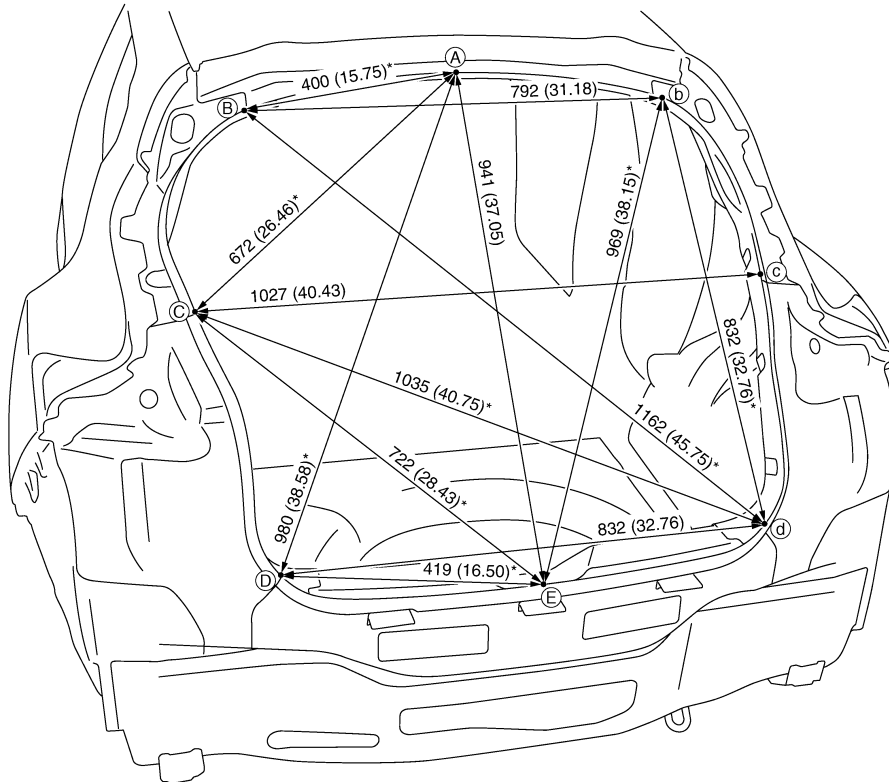

JSKIA1998GB

Unit: mm (in)

### MEASUREMENT POINTS

# BODY ALIGNMENT

< SERVICE DATA AND SPECIFICATIONS (SDS)

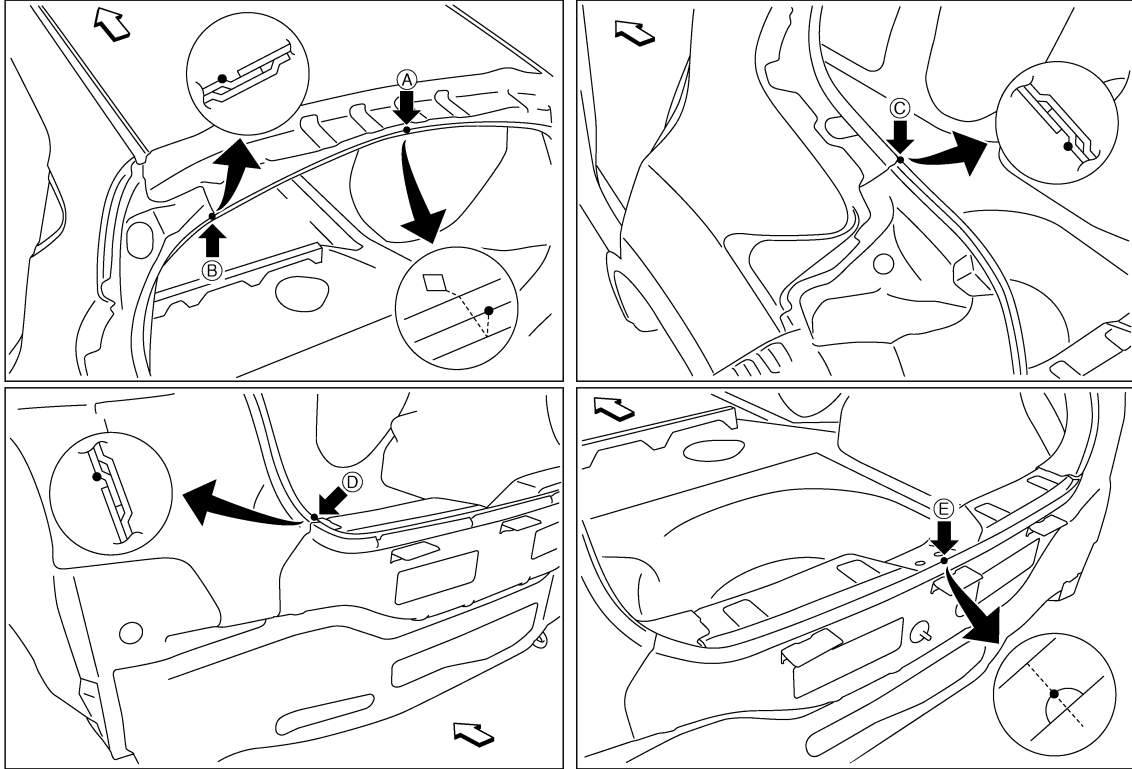

JSKIA1999ZZ

↶: Vehicle front

Point	Material	Point	Material
A	Roof flange end of center positioning mark	C, c, D, d	Rear combination lamp base joggle
B, b	Rear fender extension joggle	E	Upper rear panel indent of center positioning mark



# LOCATION OF PLASTIC PARTS

< SERVICE DATA AND SPECIFICATIONS (SDS)

## LOCATION OF PLASTIC PARTS

### Precautions for Plastics

INFOID:000000009750291

Abbreviation	Material name	Heatresisting temperature °C (°F)	Resistance to gasoline and solvents	Other cautions
PE	Polyethylene	60 (140)	Gasoline and most solvents are harmless if applied for a very short time (wipe out quickly).	Flammable
ABS	Acrylonitrile Butadiene Styrene	80 (176)	Avoid gasoline and solvents.	—
AES	Acrylonitrile Ethylene Styrene	80 (176)	↑	—
EPM/EPDM	Ethylene Propylene (Diene) copolymer	80 (176)	Gasoline and most solvents are harmless if applied for a very short time (wipe out quickly).	Flammable
PS	Polystyrene	80 (176)	Avoid solvents.	Flammable
PVC	Poly Vinyl Chloride	80 (176)	Gasoline and most solvents are harmless if applied for a very short time (wipe out quickly).	Poisonous gas is emitted when burned.
TPO	Thermoplastic Olefine	80 (176)	↑	Flammable
AAS	Acrylonitrile Acrylic Styrene	85 (185)	Avoid gasoline and solvents.	—
PMMA	Poly Methyl Methacrylate	85 (185)	↑	—
EVAC	Ethylene Vinyl Acetate	90 (194)	↑	—
PP	Polypropylene	90 (194)	Gasoline and most solvents are harmless if applied for a very short time (wipe out quickly).	Flammable, avoid battery acid.
PUR	Polyurethane	90 (194)	Avoid gasoline and solvents.	—
UP	Unsaturated Polyester	90 (194)	↑	Flammable
ASA	Acrylonitrile Styrene Acrylate	100 (212)	↑	Flammable
PPE	Poly Phenylene Ether	110 (230)	↑	—
TPU	Thermoplastic Urethane	110 (230)	↑	—
PBT+PC	Poly Butylene Terephthalate + Polycarbonate	120 (248)	↑	Flammable
PC	Polycarbonate	120 (248)	↑	—
POM	Poly Oxymethylene	120 (248)	↑	Avoid battery acid.
PA	Polyamide	140 (284)	↑	Avoid immersing in water.
PBT	Poly Butylene Terephthalate	140 (284)	↑	—
PAR	Polyarylate	180 (356)	↑	—
PET	Polyethylene terephthalate	180 (356)	↑	—
PEI	Polyetherimide	200 (392)	↑	—

**CAUTION:**

- When repairing and painting a portion of the body adjacent to plastic parts, consider their characteristics (influence of heat and solvent) and remove them if necessary or take suitable measures to protect them.
- Plastic parts should be repaired and painted using methods suiting the materials' characteristics.

A  
B  
C  
D  
E  
F  
G  
H  
I  
J  
BRM  
L  
M  
N  
O  
P

# LOCATION OF PLASTIC PARTS

< SERVICE DATA AND SPECIFICATIONS (SDS)

## Location of Plastic Parts

INFOID:000000009750292

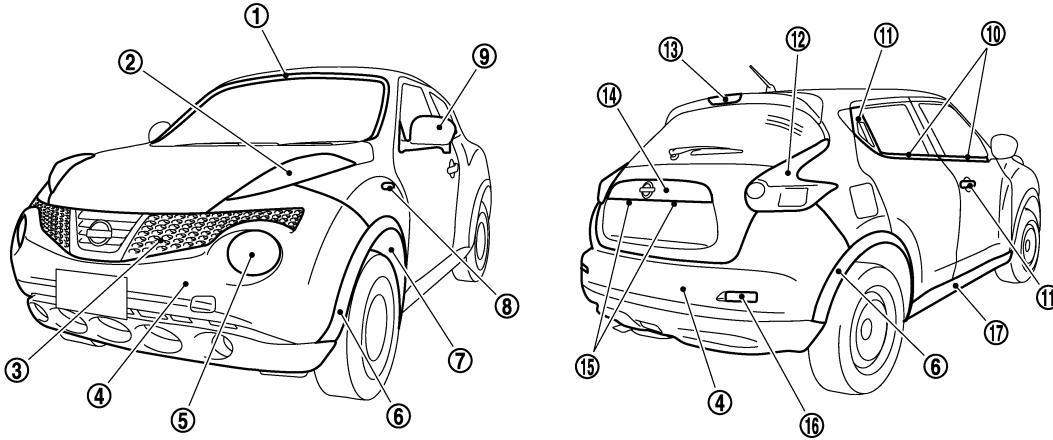

JSKIA2000ZZ

Component			Material	Component			Material
1	Windshield molding		PVC	10	Door outside molding		PVC + Stainless
2	Front combination lamp	Lens	PMMA	11	Door outside handle	Front	PC + PET
		Housing	PP			Rear	PC + PET + Glass fiber
3	Front grille		ABS	12	Rear combination lamp	Lens	PMMA
4	Bumper fascia		PP + EPM			Housing	ASA
5	Head lamp	Lens	PC	13	High mount stop lamp	Lens	PMMA
		Housing	PP			Housing	PC + ABS
6	Fillet molding		PP + EPM	14	Back door finisher		ABS
7	Front fender protector		PP	15	License plate lamp	Lens	PC
8	Side turn signal lamp	Lens	PMMA			Housing	PC
		Housing	PC + ABS	16	Reflex reflector	Lens	PMMA
9	Door outside mirror	Housing	ASA			Housing	ABS
		Base	PBT + PET	17	Center mudguard		PP + EPM
		Cover	Material color	ASA			
Body color	ABS						

# LOCATION OF PLASTIC PARTS

< SERVICE DATA AND SPECIFICATIONS (SDS)

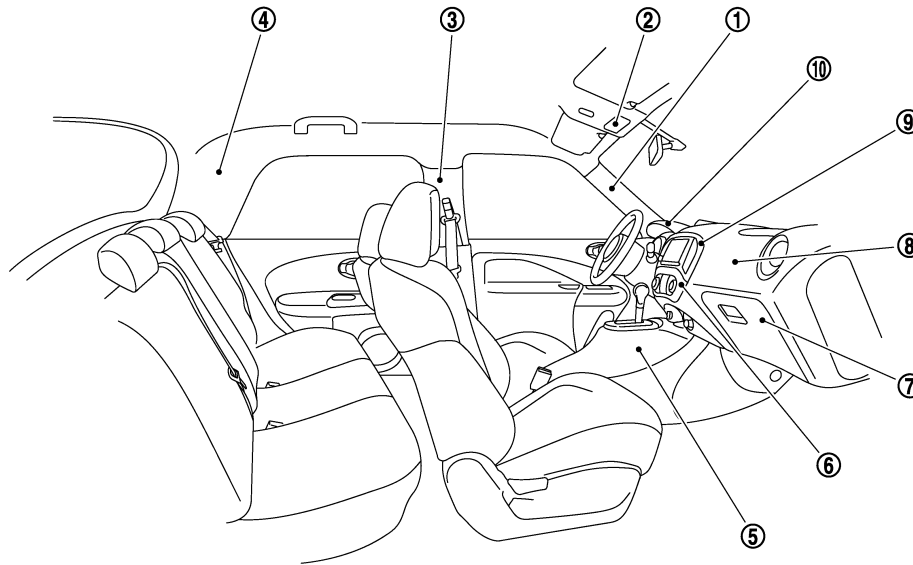

JSKIA2205ZZ

Component		Material	Component		Material	
1	Front pillar garnish	PP	6	Multi display unit	Lens	PC
2	Map lamp	Lens			PC	Finisher
		Housing	PA	7	Glove box	PP
3	Center pillar garnish	PP	8	Instrument panel	PP	
4	Rear pillar finisher	PP	9	Cluster lid C	PC + ABS	
5	Center console	PP	10	Cluster lid A	PP	

A  
B  
C  
D  
E  
F  
G  
H  
I  
J  
L  
M  
N  
O  
P

**BRM**