

SECTION **DMS**
DRIVE MODE SYSTEM

A
B
C
D
E
F
G
H
I
J
K
L
M
N
P

CONTENTS

INTEGRATED CONTROL SYSTEM	ECU DIAGNOSIS INFORMATION	9	F
PRECAUTION	MULTI DISPLAY UNIT	9	G
PRECAUTIONS	List of ECU Reference	9	
Precaution for Supplemental Restraint System (SRS) "AIR BAG" and "SEAT BELT PRE-TENSIONER"	WIRING DIAGRAM	10	H
Precautions for Removing of Battery Terminal	INTEGRATED CONTROL SYSTEM	10	
SYSTEM DESCRIPTION	Wiring Diagram	10	I
COMPONENT PARTS	BASIC INSPECTION	11	J
Component Parts Location	DIAGNOSIS AND REPAIR WORK FLOW	11	
Component Description	Work Flow	11	K
Multi Display Unit	REMOVAL AND INSTALLATION	13	L
SYSTEM	MULTI DISPLAY UNIT	13	M
System Description	Exploded View	13	
HANDLING PRECAUTION	Removal and Installation	13	N
NISSAN Dynamic Control System			P

DMS

PRECAUTION

PRECAUTIONS

Precaution for Supplemental Restraint System (SRS) "AIR BAG" and "SEAT BELT PRE-TENSIONER"

INFOID:000000009750183

The Supplemental Restraint System such as "AIR BAG" and "SEAT BELT PRE-TENSIONER", used along with a front seat belt, helps to reduce the risk or severity of injury to the driver and front passenger for certain types of collision. This system includes seat belt switch inputs and dual stage front air bag modules. The SRS system uses the seat belt switches to determine the front air bag deployment, and may only deploy one front air bag, depending on the severity of a collision and whether the front occupants are belted or unbelted. Information necessary to service the system safely is included in the "SRS AIR BAG" and "SEAT BELT" of this Service Manual.

WARNING:

Always observe the following items for preventing accidental activation.

- To avoid rendering the SRS inoperative, which could increase the risk of personal injury or death in the event of a collision that would result in air bag inflation, all maintenance must be performed by an authorized NISSAN/INFINITI dealer.
- Improper maintenance, including incorrect removal and installation of the SRS, can lead to personal injury caused by unintentional activation of the system. For removal of Spiral Cable and Air Bag Module, see "SRS AIR BAG".
- Never use electrical test equipment on any circuit related to the SRS unless instructed to in this Service Manual. SRS wiring harnesses can be identified by yellow and/or orange harnesses or harness connectors.

PRECAUTIONS WHEN USING POWER TOOLS (AIR OR ELECTRIC) AND HAMMERS

WARNING:

Always observe the following items for preventing accidental activation.

- When working near the Air Bag Diagnosis Sensor Unit or other Air Bag System sensors with the ignition ON or engine running, never use air or electric power tools or strike near the sensor(s) with a hammer. Heavy vibration could activate the sensor(s) and deploy the air bag(s), possibly causing serious injury.
- When using air or electric power tools or hammers, always switch the ignition OFF, disconnect the battery, and wait at least 3 minutes before performing any service.

Precautions for Removing of Battery Terminal

INFOID:0000000010273707

- When removing the 12V battery terminal, turn OFF the ignition switch and wait at least 30 seconds.

NOTE:

ECU may be active for several tens of seconds after the ignition switch is turned OFF. If the battery terminal is removed before ECU stops, then a DTC detection error or ECU data corruption may occur.

- For vehicles with the 2-batteries, be sure to connect the main battery and the sub battery before turning ON the ignition switch.

NOTE:

If the ignition switch is turned ON with any one of the terminals of main battery and sub battery disconnected, then DTC may be detected.

- After installing the 12V battery, always check "Self Diagnosis Result" of all ECUs and erase DTC.

NOTE:

The removal of 12V battery may cause a DTC detection error.

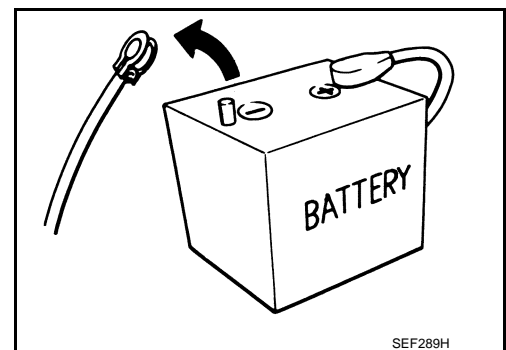

SYSTEM DESCRIPTION

COMPONENT PARTS

Component Parts Location

INFOID:000000009750184

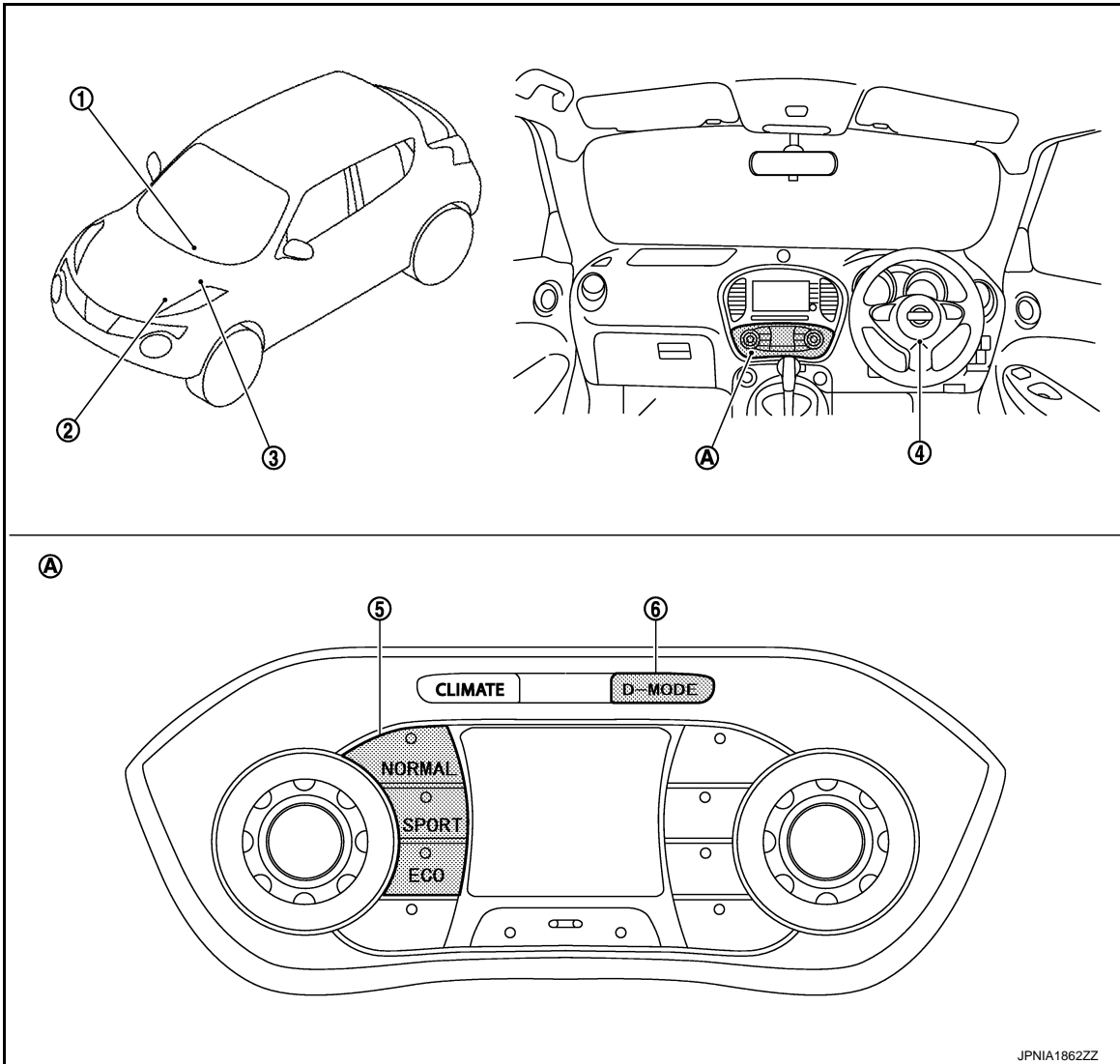

- | | | |
|--|--|---|
| <p>1. A/C auto amp
Refer to HAC-6, "Component Parts Location"</p> <p>4. EPS control unit
Refer to STC-5, "Component Parts Location"</p> <p>A. Multi display unit</p> | <p>2. ECM
Refer to EC-14, "ENGINE CONTROL SYSTEM : Component Parts Location"</p> <p>5. Drive mode switch
• NORMAL switch
• SPORT switch
• ECO switch</p> | <p>3. TCM
Refer to TM-150, "CVT CONTROL SYSTEM : Component Parts Location"</p> <p>6. D-MODE select switch</p> |
|--|--|---|

A
B
C
D
E
F
G
H
I
J
K
L
M
N
P

DMS

COMPONENT PARTS

< SYSTEM DESCRIPTION >

[INTEGRATED CONTROL SYSTEM]

Component Description

INFOID:000000009750185

Part name	Description
Multi display unit	Transmits the ON/OFF status of each mode of the drive mode switch (NORMAL, SPORT, ECO) to TCM (CVT models), ECM (M/T models), EPS control unit and the A/C auto amp via CAN communication.
ECM	Based on the mode signals received from TCM (CVT models) or multi display unit (M/T models) via CAN communication, changes over the throttle position and other characteristics.
TCM	Based on the mode signals received from the multi display unit via CAN communication, changes over the gear shift line and other characteristics.
EPS control unit	Based on the mode signals received from the multi display unit via CAN communication, changes over the steering assist characteristic.
A/C auto amp	Based on the ECO mode signal received from the multi display unit via CAN communication, changes over the set temperature correction.

Multi Display Unit

INFOID:000000009750186

DESCRIPTION

- The multi display unit connects to other units via CAN communication and performs the drive mode control.
- The following 3 drive modes are available, NORMAL, SPORT, and ECO.
- The drive mode can be changed over as desired by pressing the D-MODE select switch. The characteristics of the engine, CVT, steering and air conditioner are changed accordingly.
- The display shows the current drive mode (NORMAL, SPORT, ECO) as well as the vehicle information for the mode.

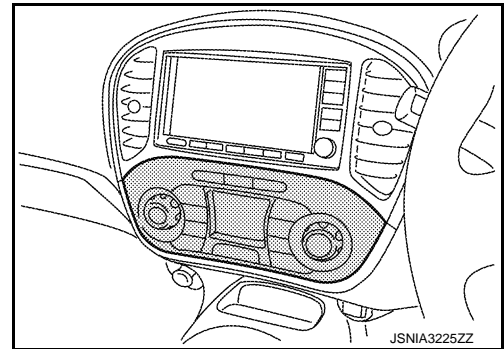

VEHICLE INFORMATION DISPLAY



Drive Mode

Item	Display content	Display
NORMAL mode	<ul style="list-style-type: none"> • Displays the input voltage to the multi display unit in 5 grades. • Displays the engine torque in 5 grades. 	

COMPONENT PARTS

< SYSTEM DESCRIPTION >

[INTEGRATED CONTROL SYSTEM]

Item	Display content	Display
SPORT mode	Displays the boost pressure in 5 grades.	 <p style="text-align: right; font-size: small;">AVA1257</p>
ECO mode	Displays the instantaneous fuel consumption in 5 grades.	 <p style="text-align: right; font-size: small;">AVA1254</p>

A
B
C
D
E
F
G
H
I
J
K
L
M
N
P

DMS

SYSTEM

System Description

INFOID:000000009750187

SYSTEM DIAGRAM

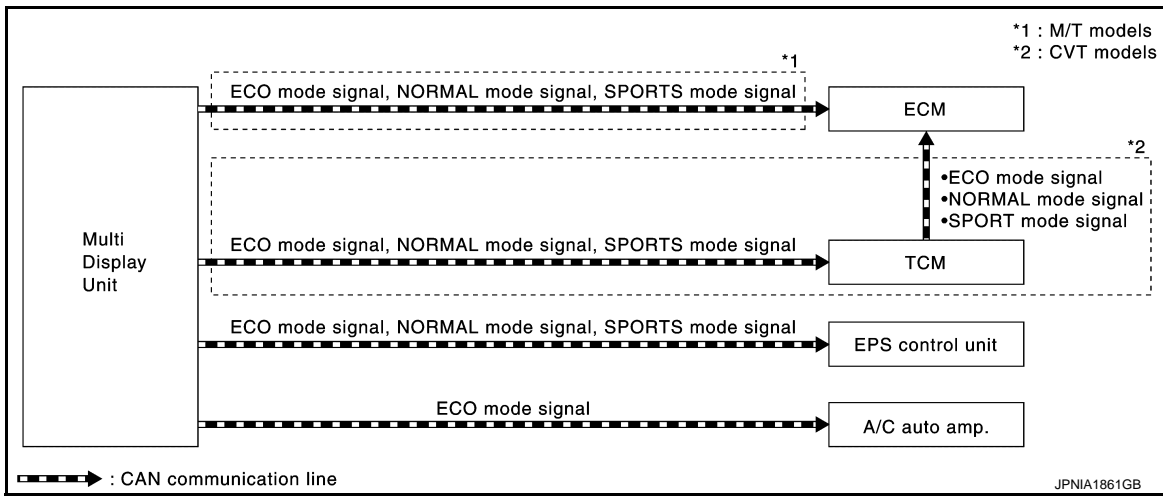

- The multi display unit transmits the operation status of the drive mode switch to other units via CAN communication as the mode signal (refer below).
 - NORMAL: ON/OFF
 - SPORT: ON/OFF
 - ECO: ON/OFF
- Based on the mode signals received from TCM (CVT models) or multi display unit (M/T models) via CAN communication, ECM changes over the throttle position and other characteristics.
- Based on the mode signals received from the multi display unit via CAN communication, TCM changes over the gear shift line and other characteristics.
- Based on the mode signals received from the multi display unit via CAN communication, EPS C/U changes the steering assist characteristic.
- Based on the ECO mode signal received from the multi display unit via CAN communication, the A/C auto amp changes over the set temperature correction.

CONTROL DESCRIPTION

- The drive mode switch in the controller of the multi display unit is used to change over the vehicle mode and thus change the control characteristics for the engine, transaxle, steering, and air conditioner.

Function Apply List

		MR16DDT	
		M/T	CVT
SPORTS	ENGINE	×	×
	CVT		×
	STEERING	×	×
ECO	ENGINE	×	×
	CVT		×
	AIR CONDITIONER	×	×

- With the NORMAL mode as the base mode, the control of vehicle characteristics is changed over to the following modes.
 - SPORT: The control characteristics for the engine, transaxle, and steering system are changed so that a sporty feel is created in the driving behavior.
 - ECO: The control characteristics for the engine, transaxle, and automatic air conditioner are changed to help improve the practical fuel economy.

SYSTEM

< SYSTEM DESCRIPTION >

[INTEGRATED CONTROL SYSTEM]

Control item		Control mode			Control
		SPORT	NORMAL	ECO	
ENGINE	Throttle position characteristic	× Half open	—	—	Improves the engine response to acceleration pedal operation and enhances the torque feel.
		—	—	× Late opening	Accelerates gently to assist in ECO driving.
	Speed limiter for throttle position	—	—	×	Controls the throttle position to a smaller level than NORMAL to help improve the practical fuel consumption.
TRANSAXLE	High speed gear shift line	×	—	—	Keeps the engine speed at a high level and improves the acceleration dynamism and response.
	Downshift upon braking	×	—	—	performs downshift upon braking before cornering to prevent a drop in the engine speed.
	Cornering ratio hold	×	—	—	Helps the vehicle clear a curve smoothly by restricting shift changes during cornering.
	Low speed gear shift line	—	—	×	Improves the practical fuel economy by controlling the engine speed to a low level.
STEERING	Assist characteristic	×	—	—	Changes the steering assist characteristic to enhance a stable steering feel.
AIR CONDITIONER	Air inlet control	—	—	×	Reduces the engine load by optimizing the air conditioner control to a level that does not adversely affect the interior comfort and thus helps improve the practical fuel economy.
	Blower fan control	—	—	×	

ENGINE, TRANSAXLE, STEERING, AIR CONDITIONER CONTROL

- For details on the engine control, refer to [EC-56, "INTEGRATED CONTROL SYSTEM : System Description"](#).
- For details on the transaxle control, refer to [TM-181, "INTEGRATED CONTROL SYSTEM : System Description"](#).
- For details on the steering control, refer to [STC-7, "EPS SYSTEM : System Description"](#).
- For details on the air conditioner control, refer to [HAC-18, "ECO Mode Control"](#).

A
B
C
D
E
F
G
H
I
J
K
L
M
N
P

DMS

HANDLING PRECAUTION

NISSAN Dynamic Control System

INFOID:000000009750188

- The engine torque, engine power, boost pressure, and instantaneous fuel consumption are provided for information purposes only. They are not intended to prompt the driver to adjust driving style. The readings may be slightly delayed relative to the actual vehicle behaviors. This is not a malfunction.
- The voltmeter reading cannot be used as an indicator for battery replacement because it indicates the input voltage to the multi display unit, not the battery voltage.
- The ECO information screen is operable only while the vehicle is stopped.
- If no time setting is performed, the daily and weekly fuel consumption history data are not displayed.
- The readings may differ from the actual values depending on driving conditions.

ECU DIAGNOSIS INFORMATION

MULTI DISPLAY UNIT

List of ECU Reference

INFOID:000000009750189

ECU	Reference
Muiti display unit	AV-165. "Reference Value"
	AV-167. "DTC Inspection Priority Chart"
	AV-168. "DTC Index"

A
B
C
D
E
F
G
H
I
J
K
L
M
N
P

DMS

INTEGRATED CONTROL SYSTEM

< WIRING DIAGRAM >

[INTEGRATED CONTROL SYSTEM]

WIRING DIAGRAM

INTEGRATED CONTROL SYSTEM

Wiring Diagram

INFOID:000000009750190

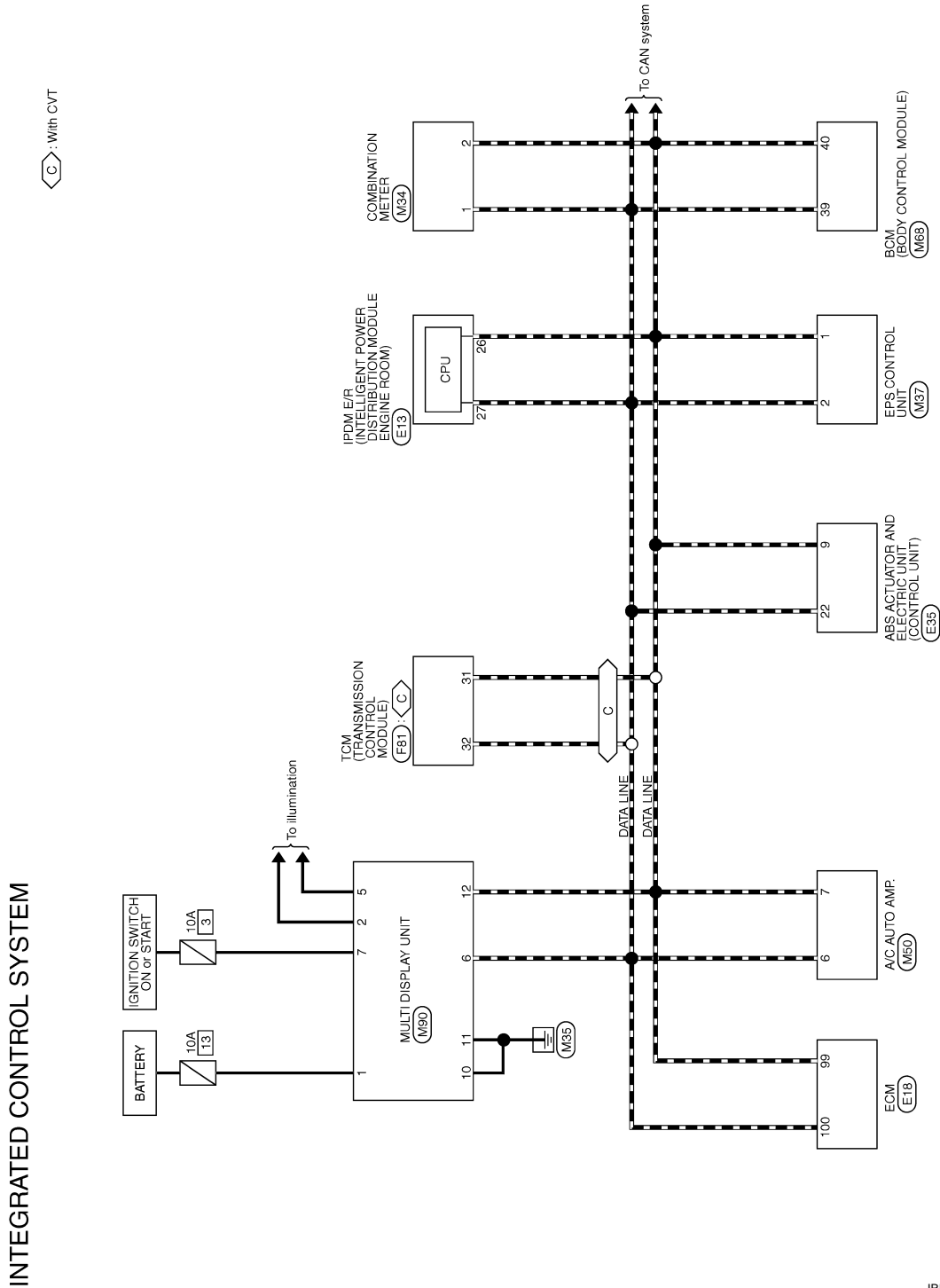

BASIC INSPECTION

DIAGNOSIS AND REPAIR WORK FLOW

Work Flow

INFOID:000000009750191

DESCRIPTION OF TROUBLE DIAGNOSIS FLOWCHART

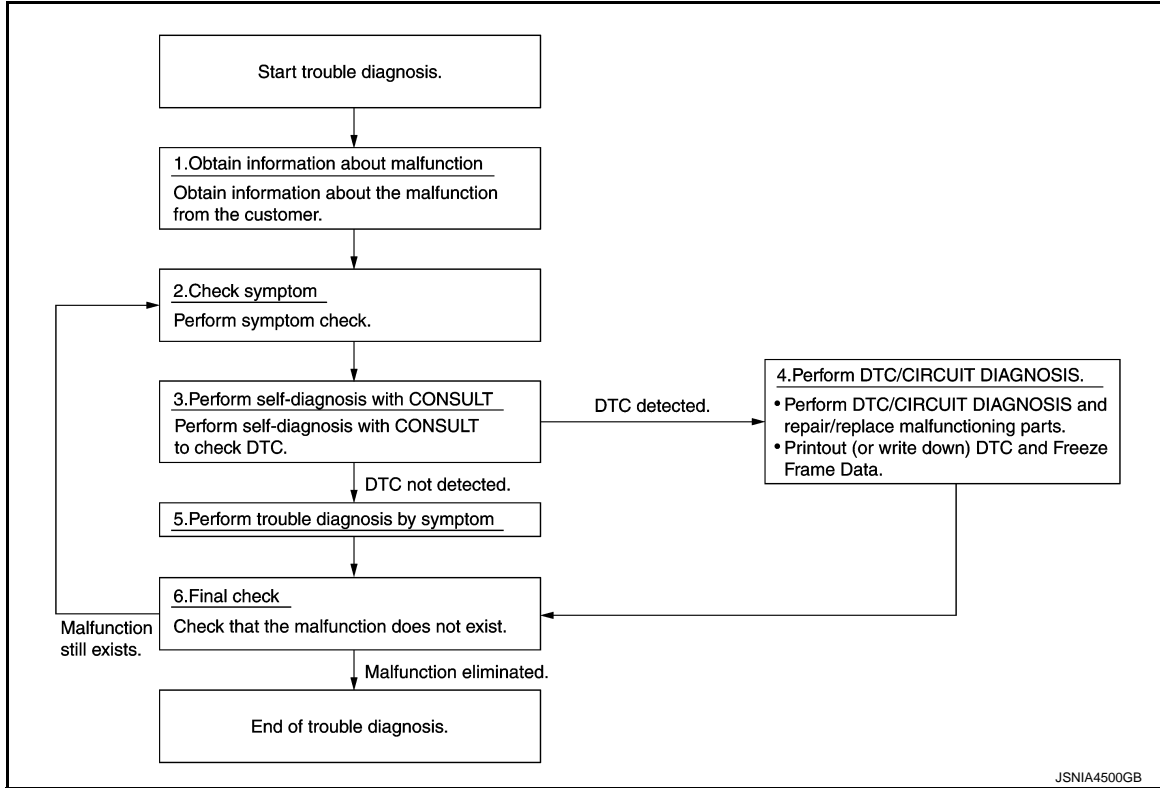

DETAILS OF TROUBLE DIAGNOSIS FLOWCHART

1. OBTAIN INFORMATION ABOUT SYMPTOM

Interview the customer to obtain as much information as possible about the conditions and environment under which the malfunction occurs.

>> GO TO 2.

2. CHECK SYMPTOM

- Check the symptom based on the information obtained from the customer.
- Check if any other malfunctions are present.

>> GO TO 3.

3. CONSULT SELF-DIAGNOSIS

1. Perform "MULTI DISPLAY" "self diagnosis" by connecting CONSULT.
2. When DTC is detected, follow the instructions below:
 - Record DTC and Freeze Frame Data.

NOTE:

If "CAN COM CIRC [U1000]" is displayed, start the diagnosis from the CAN communication system. Refer to [AV-174. "Diagnosis Procedure"](#).

Is any DTC No. displayed?

- YES >> GO TO 4.
- NO >> GO TO 5.

4. DTC/SYSTEM DIAGNOSIS



DIAGNOSIS AND REPAIR WORK FLOW

< BASIC INSPECTION >

[INTEGRATED CONTROL SYSTEM]

1. Perform a DTC/system diagnosis and repair or replace any malfunctioning part.
2. When DTC is detected, follow the instructions below:
 - Record DTC and Freeze Frame Data.

>> GO TO 6.

5. PERFORM DIAGNOSIS BY SYMPTOM

Perform a diagnosis by symptom and repair or replace any malfunctioning part.

>> GO TO 6.

6. FINAL CHECK

Check that the multi display unit functions normally.

Does it operate normally?

- YES >> End of trouble diagnosis
- NO >> GO TO 2.

MULTI DISPLAY UNIT

< REMOVAL AND INSTALLATION >

[INTEGRATED CONTROL SYSTEM]

REMOVAL AND INSTALLATION

MULTI DISPLAY UNIT

Exploded View

INFOID:000000009750192

REMOVAL

Refer to [IP-12. "Exploded View"](#).

DISASSEMBLY

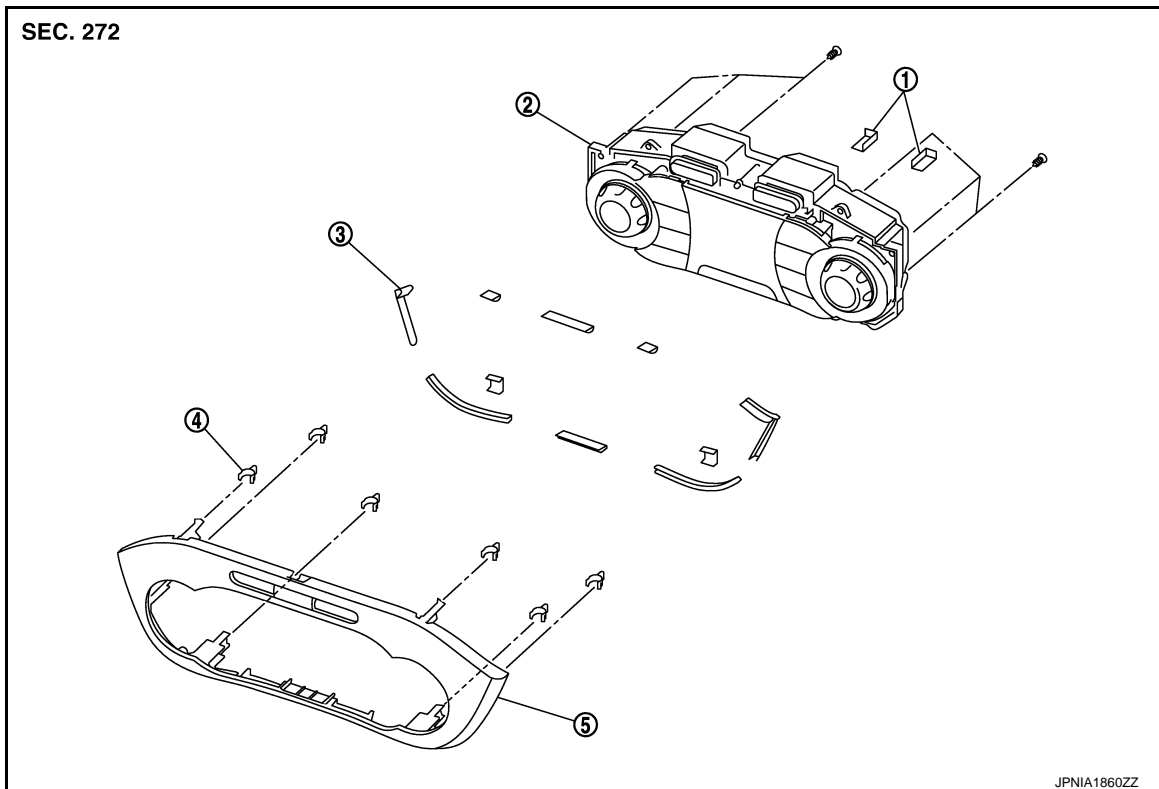

- | | | |
|------------------|-----------------------|------------------|
| 1. Silencer tape | 2. Multi display unit | 3. Silencer tape |
| 4. Clip | 5. Control finisher | |

Removal and Installation

INFOID:000000009750193

REMOVAL

Refer to [IP-12. "Exploded View"](#).

CAUTION:

- When performing the work, use a shop cloth to protect the parts from damage.
- Always fix the harness clamp in position.

INSTALLATION

Install in the reverse order of removal.

A
B
C
D
E
F
G
H
I
J
K
L
M
N
P

DMS