

SECTION **GI**
GENERAL INFORMATION

B
C
D
E
F
G
H
I
J
K
L
M
N
O
P

CONTENTS

HOW TO USE THIS MANUAL	3	Precaution for Procedure without Cowl Top Cover...	25
HOW TO USE THIS MANUAL	3	Precautions for Removing of Battery Terminal	26
Description	3	General Precautions	26
Terms	3	Three Way Catalyst	27
Units	3	Multiport Fuel Injection System or Engine Control	
Contents	3	System	28
Relation between Illustrations and Descriptions	4	Precaution for Turbocharger	28
Components	4	Hoses	28
HOW TO FOLLOW TROUBLE DIAGNOSES	6	Engine Oils	29
Description	6	Air Conditioning	29
How to Follow Test Groups in Trouble Diagnosis.....	6	Fuel	30
Key to Symbols Signifying Measurements or Pro-		LIFTING POINT	31
cedures	7	Commercial Service Tools	31
HOW TO READ WIRING DIAGRAMS	9	Garage Jack and Safety Stand and 2-Pole Lift	31
Connector Symbols	9	Board-On Lift	32
Sample/Wiring Diagram -Example-	10	TOW TRUCK TOWING	33
Connector Information	12	Tow Truck Towing	33
How to Repair Aluminum Wires	13	Vehicle Recovery (Freeing a Stuck Vehicle)	34
ABBREVIATIONS	16	PREPARATION	36
Abbreviation List	16	PREPARATION	36
TIGHTENING TORQUE OF STANDARD		Special Service Tools	36
BOLTS	21	Commercial Service Tools	36
Description	21	Repair Parts	36
Tightening Torque Table (New Standard Includ-		VEHICLE INFORMATION	37
ed)	21	IDENTIFICATION INFORMATION	37
RECOMMENDED CHEMICAL PRODUCTS		Model Variation	37
AND SEALANTS	24	Information About Identification or Model Code	38
Recommended Chemical Products and Sealants...	24	Dimensions	41
PRECAUTION	25	Wheels & Tires	41
PRECAUTIONS	25	BASIC INSPECTION	42
Description	25	SERVICE INFORMATION FOR ELECTRICAL	
Precaution for Supplemental Restraint System		INCIDENT	42
(SRS) "AIR BAG" and "SEAT BELT PRE-TEN-		Work Flow	42
SIONER"	25	Control Units and Electrical Parts	42

How to Check Terminal	43	Wiring Diagram - CONSULT/GST CHECKING	
Intermittent Incident	46	SYSTEM -	56
Circuit Inspection	49		
CONSULT/GST CHECKING SYSTEM	54	INSPECTION AND ADJUSTMENT	61
Description	54	ADDITIONAL SERVICE WHEN REMOVING BAT-	
CONSULT Function and System Application*1	54	TERY NEGATIVE TERMINAL	61
CONSULT/GST Data Link Connector (DLC) Cir-		ADDITIONAL SERVICE WHEN REMOVING	
cuit	55	BATTERY NEGATIVE TERMINAL : Required	
		Procedure After Battery Disconnection	61

HOW TO USE THIS MANUAL

< HOW TO USE THIS MANUAL >

HOW TO USE THIS MANUAL

HOW TO USE THIS MANUAL

GI

Description

INFOID:000000009754813

This volume explains "Removal, Disassembly, Installation, Inspection and Adjustment" and "Trouble Diagnoses".

Terms

INFOID:000000009754814

- The captions **WARNING** and **CAUTION** warn you of steps that must be followed to prevent personal injury and/or damage to some part of the vehicle.

WARNING indicates the possibility of personal injury if instructions are not followed.

CAUTION indicates the possibility of component damage if instructions are not followed.

BOLD TYPED STATEMENTS except **WARNING** and **CAUTION** give you helpful information.

Standard value: Tolerance at inspection and adjustment.

Limit value: The maximum or minimum limit value that should not be exceeded at inspection and adjustment.

Units

INFOID:000000009754815

- The **UNITS** given in this manual are primarily expressed as the SI UNIT (International System of Unit), and alternatively expressed in the metric system and in the yard/pound system. Also with regard to tightening torque of bolts and nuts, there are descriptions both about range and about the standard tightening torque.

"Example"

Range

Outer Socket Lock Nut : 59 - 78 N-m (6.0 - 8.0 kg-m, 43 - 58 ft-lb)

Standard

Drive Shaft Installation Bolt : 44.3 N-m (4.5 kg-m, 33 ft-lb)

Contents

INFOID:000000009754816

- A **QUICK REFERENCE INDEX**, a black tab (e.g. **BR**) is provided on the first page. You can quickly find the first page of each section by matching it to the section's black tab.
- **THE CONTENTS** are listed on the first page of each section.
- **THE TITLE** is indicated on the upper portion of each page and shows the part or system.
- **THE PAGE NUMBER** of each section consists of two or three letters which designate the particular section and a number (e.g. "BR-5").
- **THE SMALL ILLUSTRATIONS** show the important steps such as inspection, use of special tools, knacks of work and hidden or tricky steps which are not shown in the previous large illustrations. Assembly, inspection and adjustment procedures for the complicated units such as the automatic transaxle or transmission, etc. are presented in a step-by-step format where necessary.

HOW TO USE THIS MANUAL

< HOW TO USE THIS MANUAL >

Relation between Illustrations and Descriptions

INFOID:000000009754817

The following sample explains the relationship between the part description in an illustration, the part name in the text and the service procedures.

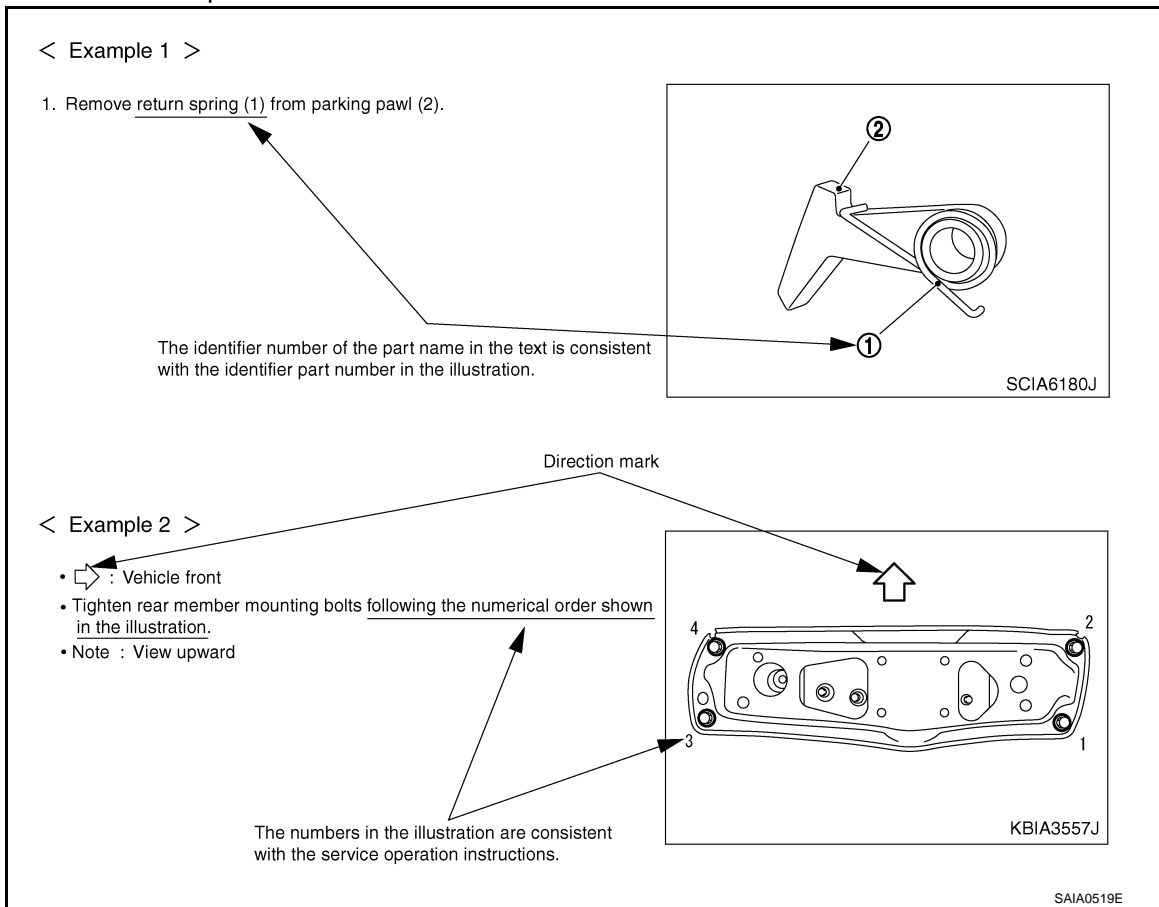

Components

INFOID:000000009754818

- **THE LARGE ILLUSTRATIONS** are exploded views (see the following) and contain tightening torques, lubrication points, section number of the **PARTS CATALOG** (e.g. SEC. 440) and other information necessary to perform repairs.

The illustrations should be used in reference to service matters only. When ordering parts, refer to the appropriate **PARTS CATALOG**.

Components shown in an illustration may be identified by a circled number. When this style of illustration is used, the text description of the components will follow the illustration.

HOW TO USE THIS MANUAL

< HOW TO USE THIS MANUAL >

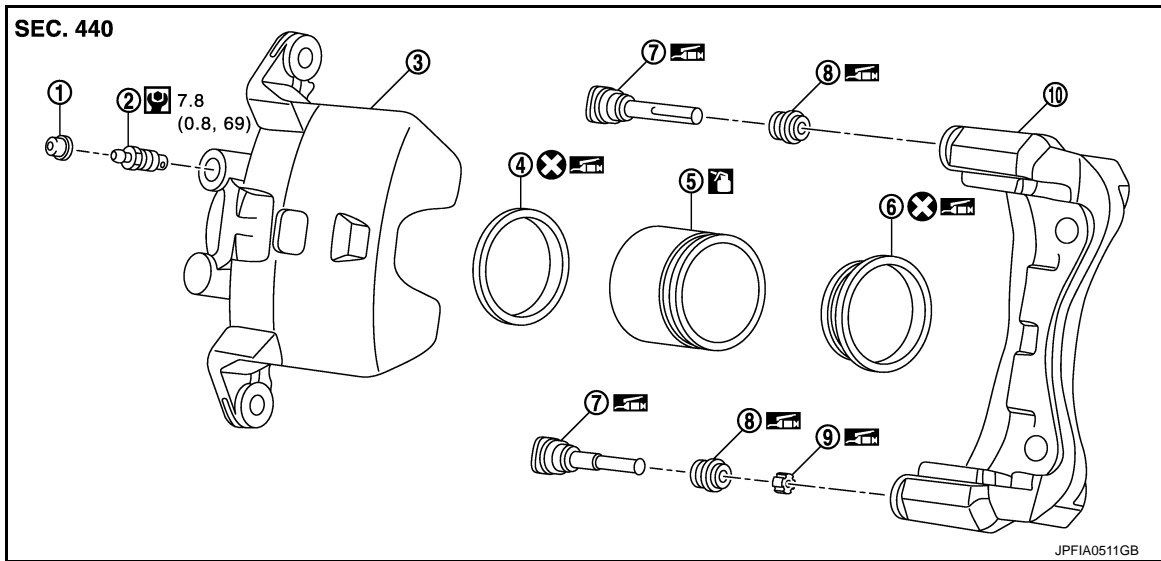

- | | | |
|-------------------|---------------------|------------------|
| 1. Cap | 2. Bleeder valve | 3. Cylinder body |
| 4. Piston seal | 5. Piston | 6. Piston boot |
| 7. Sliding pin | 8. Sliding pin boot | 9. Bushing |
| 10. Torque member | | |

: Apply rubber grease.

: Apply brake fluid.

: N·m (kg·m, in·lb)

: Always replace after every disassembly.

SYMBOLS

SYMBOL	DESCRIPTION	SYMBOL	DESCRIPTION
	Tightening torque The tightening torque specifications of bolts and nuts may be presented as either a range or a standard tightening torque.		N·m (kg·m, ft·lb)
			N·m (kg·m, in·lb)
	Should be lubricated with grease. Unless otherwise indicated, use recommended multi-purpose grease.		Apply petroleum jelly.
	Should be lubricated with oil.		Apply molybdenum added petroleum jelly.
	Sealing point		Apply ATF.
	Sealing point with locking sealant.		Select with proper thickness.
	Checking point		Adjustment is required.
			Always replace after every disassembly.

SAIA0749E

HOW TO FOLLOW TROUBLE DIAGNOSES

< HOW TO USE THIS MANUAL >

HOW TO FOLLOW TROUBLE DIAGNOSES

Description

INFOID:000000009754819

NOTICE:

Trouble diagnoses indicate work procedures required to diagnose problems effectively. Observe the following instructions before diagnosing.

- Before performing trouble diagnoses, read the “Work Flow” in each section.
- After repairs, re-check that the problem has been completely eliminated.
- Refer to Component Parts and Harness Connector Location for the Systems described in each section for identification/location of components and harness connectors.
- When checking circuit continuity, ignition switch should be OFF.
- Refer to the Circuit Diagram for quick pinpoint check.

If you need to check circuit continuity between harness connectors in more detail, such as when a sub-harness is used, refer to Wiring Diagram in each individual section and Harness Layout in PG section for identification of harness connectors.

- Before checking voltage at connectors, check battery voltage.
- After accomplishing the Diagnosis Procedures and Electrical Components Inspection, check that all harness connectors are reconnected as they were.

How to Follow Test Groups in Trouble Diagnosis

INFOID:000000009754820

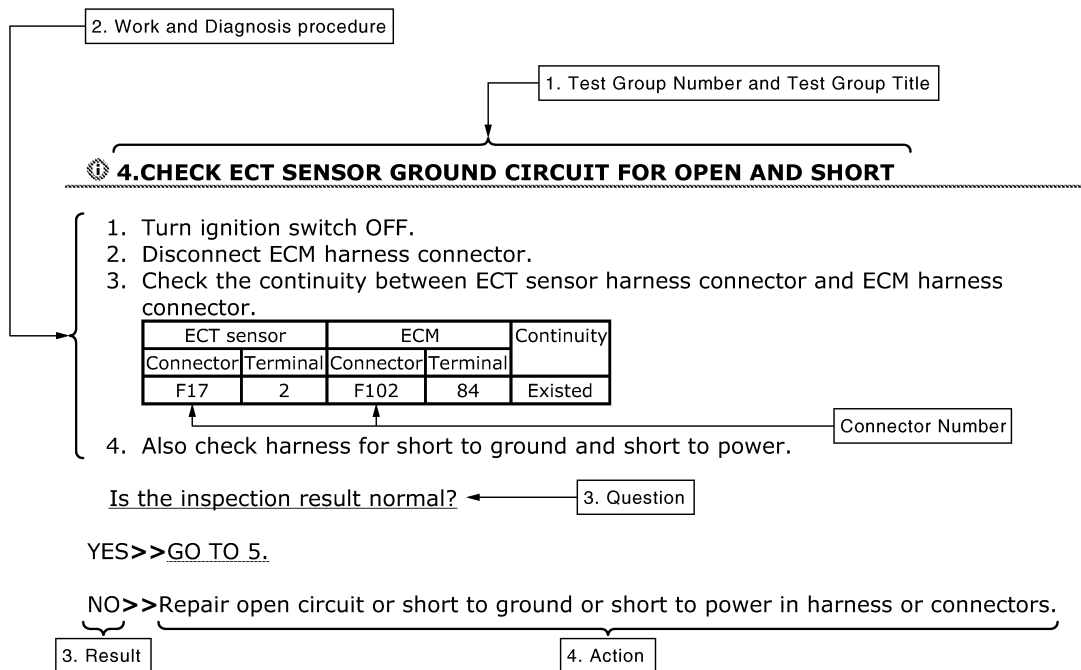

JPAIA0021GB

1. Test group number and test group title
 - Test group number and test group title are shown in the upper portion of each test group.
2. Work and diagnosis procedure
 - Start to diagnose a problem using procedures indicated in enclosed test groups.
3. Questions and results
 - Questions and required results are indicated in test group.
4. Action
 - Next action for each test group is indicated based on result of each question.

HOW TO FOLLOW TROUBLE DIAGNOSES

< HOW TO USE THIS MANUAL >

Key to Symbols Signifying Measurements or Procedures

INFOID:000000009754821

SYMBOL	DESCRIPTION	SYMBOL	DESCRIPTION
	Check after disconnecting the connector to be measured.		Procedure with Generic Scan Tool. (GST, OBD-II scan tool)
	Check after connecting the connector to be measured.		Procedure without CONSULT or GST
	Insert key into ignition switch.		A/C switch is "OFF".
	Remove key from ignition switch.		A/C switch is "ON".
	Insert and remove key repeatedly.		REC switch is "ON".
	Turn ignition switch to "OFF" position.		REC switch is "OFF".
	Turn ignition switch to "ACC" position.		Fan switch is "ON". (At any position except for "OFF" position)
	Turn ignition switch to "ON" position.		Fan switch is "OFF".
	Turn ignition switch to "START" position.		Apply fuse.
	Turn ignition switch from "OFF" to "ACC" position.		Apply positive voltage from battery with fuse directly to components.
	Turn ignition switch from "ACC" to "ON" position.		
	Turn ignition switch from "ACC" to "OFF" position.		

JPAIA0982GB

GI

B

C

D

E

F

G

H

I

J

K

L

M



N

O

P

HOW TO FOLLOW TROUBLE DIAGNOSES

< HOW TO USE THIS MANUAL >

SYMBOL	DESCRIPTION	SYMBOL	DESCRIPTION
	Turn ignition switch from "OFF" to "ON" position.		Drive vehicle.
	Turn ignition switch from "ON" to "OFF" position.		
	Do not start engine, or check with engine stopped.		Disconnect battery negative cable.
	Start engine, or check with engine running.		Depress brake pedal.
	Apply parking brake.		Release brake pedal.
	Release parking brake.		Depress accelerator pedal.
	Release parking brake.		Release accelerator pedal.
	Check after engine is warmed up sufficiently.	  	Pin terminal check for SMJ type ECM or TCM connectors. For details regarding the terminal arrangement, refer to the "ELECTRICAL UNITS" electrical reference page at the end of the manual.
	Voltage should be measured with a voltmeter.		
	Circuit resistance should be measured with an ohmmeter.		
			
	Current should be measured with an ammeter.		
	Pulse signal should be checked with an oscilloscope.		
	Procedure with CONSULT		
	Procedure without CONSULT		
	Place selector lever in "P" position.		
	Place selector lever in "N" position.		
	Jack up front portion.		
	Jack up rear portion.		
	Inspect under engine room.		
	Inspect under floor.		
	Inspect rear under floor.		

JSAIA1461GB

HOW TO READ WIRING DIAGRAMS

< HOW TO USE THIS MANUAL >

HOW TO READ WIRING DIAGRAMS

Connector Symbols

INFOID:000000010097941

Most of connector symbols in wiring diagrams are shown from the terminal side.

- Connector symbols shown from the terminal side are enclosed by a single line and followed by the direction mark.
- Connector symbols shown from the harness side are enclosed by a double line and followed by the direction mark.
- Certain systems and components, especially those related to OBD, may use a new style slide-locking type harness connector. For description and how to disconnect, refer to PG section, "Description", "HARNESS CONNECTOR".

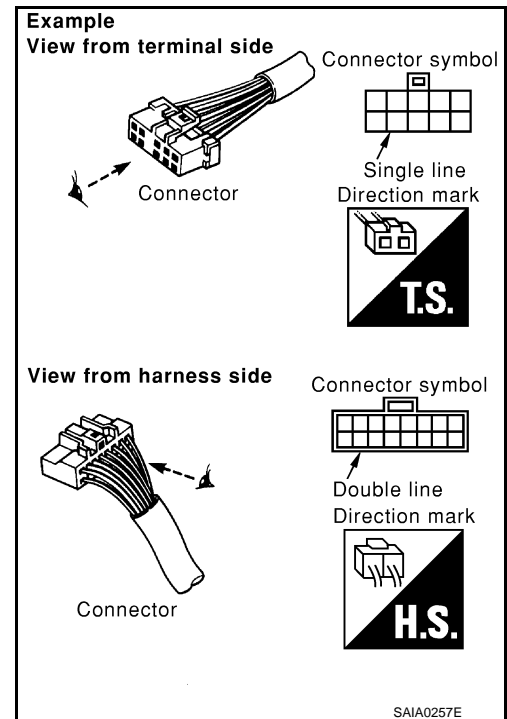

- Male and female terminals
Connector guides for male terminals are shown in black and female terminals in white in wiring diagrams.

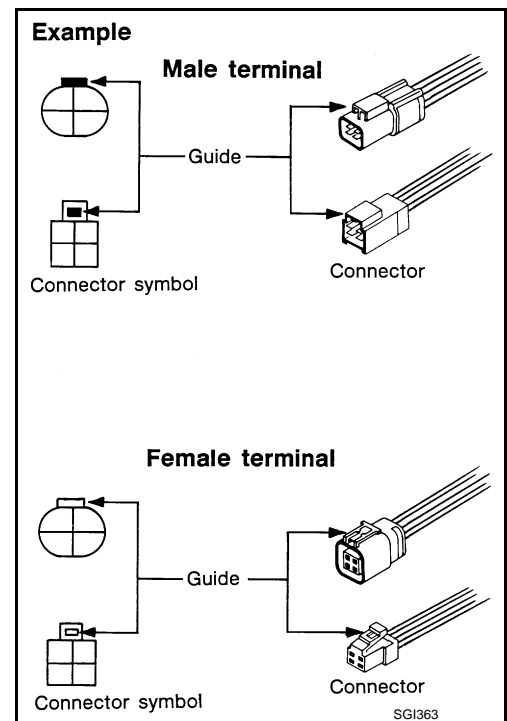

GI
B
C
D
E
F
G
H
I
J
K
L
M
N
O
P

HOW TO READ WIRING DIAGRAMS

< HOW TO USE THIS MANUAL >

Sample/Wiring Diagram -Example-

INFOID:000000010097942

Each section includes wiring diagrams.

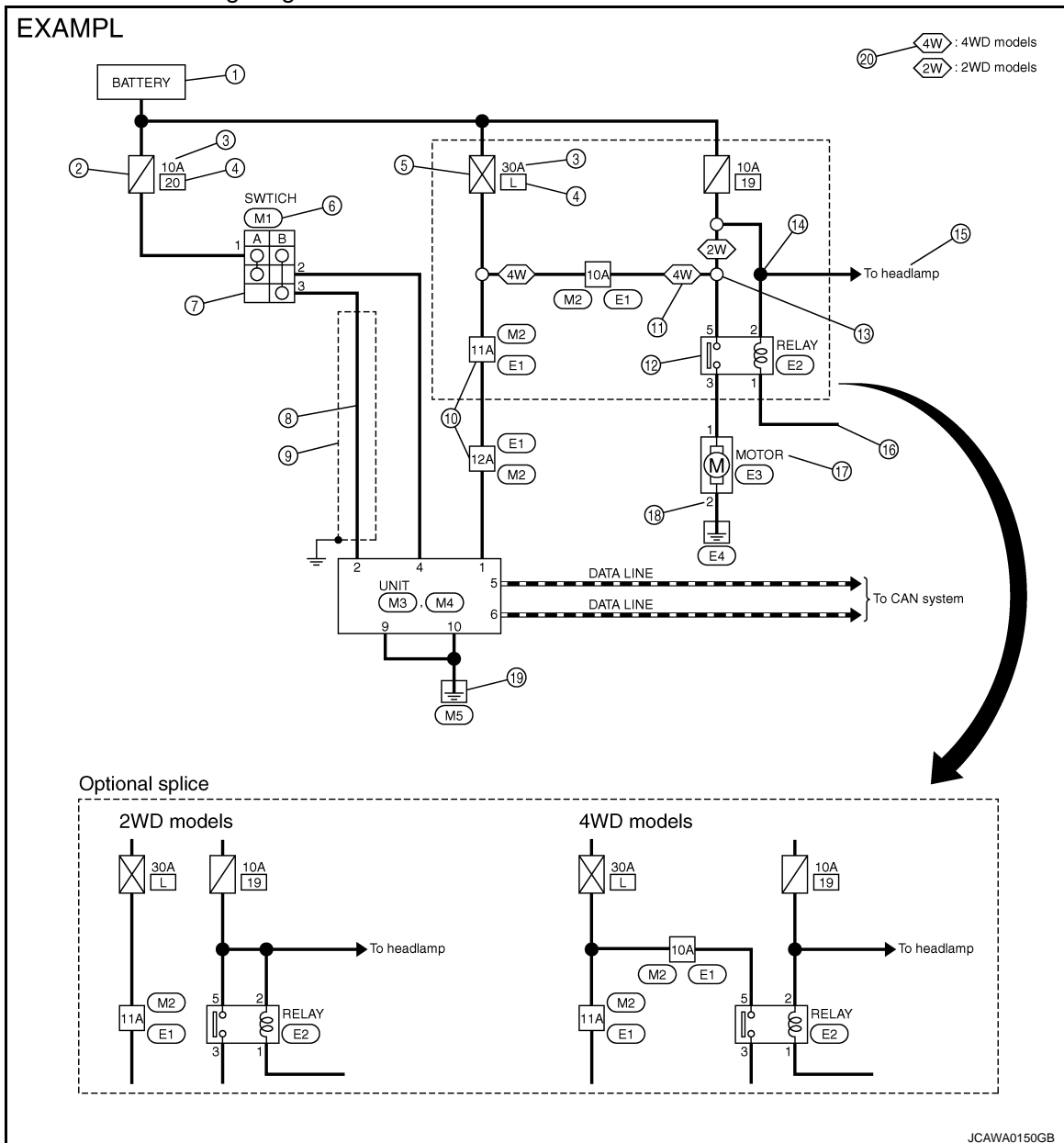

Description

Number	Item	Description
1	Power supply	• This means the power supply of fusible link or fuse.
2	Fuse	• “/” means the fuse.
3	Current rating of fusible link/fuse	• This means the current rating of the fusible link or fuse.
4	Number of fusible link/fuse	• This means the number of fusible link or fuse location.
5	Fusible link	• “X” means the fusible link.
6	Connector number	• Alphabetic characters show to which harness the connector is placed. • Numeric characters show the identification number of connectors.
7	Switch	• This shows that continuity exists between terminals 1 and 2 when the switch is in the A position. Continuity exists between terminals 1 and 3 when the switch is in the B position.
8	Circuit (Wiring)	• This means the wiring.

HOW TO READ WIRING DIAGRAMS

< HOW TO USE THIS MANUAL >

Number	Item	Description
9	Shielded line	• The line enclosed by broken line circle shows shield wire.
10	Connectors	• This means that a transmission line bypasses two connectors or more.
11	Option abbreviation	• This means the vehicle specifications which layouts the circuit between “O”.
12	Relay	• This shows an internal representation of the relay.
13	Optional splice	• The open circle shows that the splice is optional depending on vehicle application.
14	Splice	• The shaded circle “●” means the splice.
15	System branch	• This shows that the circuit is branched to other systems.
16	Page crossing	• This circuit continues to an adjacent page.
17	Component name	• This shows the name of a component.
18	Terminal number	• This means the terminal number of a connector.
19	Ground (GND)	• This shows the ground connection.
20	Explanation of option description	• This shows a description of the option abbreviation used on the page.

SWITCH POSITIONS

Switches are shown in wiring diagrams as if the vehicle is in the “normal” condition.

A vehicle is in the “normal” condition when:

- ignition switch is “OFF”
- doors, hood and trunk lid/back door are closed
- pedals are not depressed
- parking brake is released

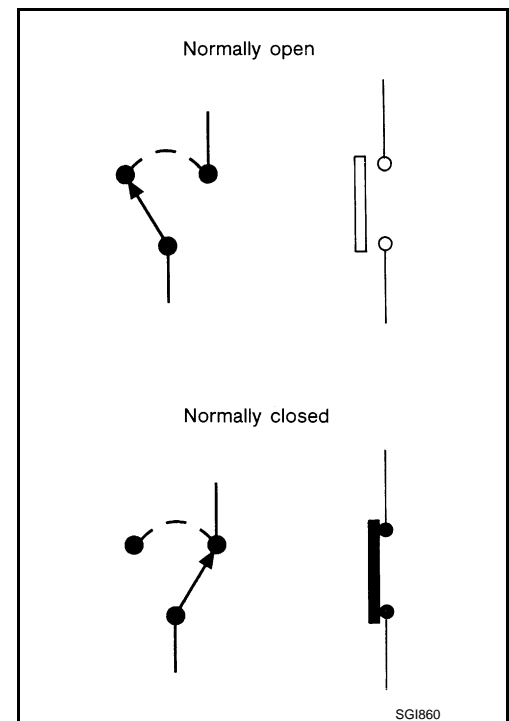

MULTIPLE SWITCH

The continuity of multiple switch is described in two ways as shown below.

- The switch chart is used in schematic diagrams.

HOW TO READ WIRING DIAGRAMS

< HOW TO USE THIS MANUAL >

- The switch diagram is used in wiring diagrams.

Example

(SWITCH CHART)

WIPER SWITCH		OFF	INT	LO	HI	WASH
1						○
2					○	
3	○	○	○			
4	○	○	○	○		
5		○				
6		○	○	○	○	

(SWITCH DIAGRAM)

Both switches are turned in combination.

Continuity circuit of wiper switch

SWITCH POSITION	CONTINUITY CIRCUIT
OFF	3-4
INT	3-4, 5-6
LO	3-6
HI	2-6
WASH	1-6

JSAIA0017GB

Connector Information

INFOID:000000010097943

HOW TO USE CONNECTOR INFORMATION

① Connector No. M3

Connector Name UNIT

② Connector Type NS06FW-M2

H.S.

③ ④

Terminal No.	Color of Wire	Signal Name [Specification]
1	W	BAT
2	G	SWITCH B
4	V	SWITCH A
5	L	CAN-H
6	P	CAN-L

⑤

Connector No. M4

Connector Name UNIT

Connector Type NS10FW-CS

H.S.

Terminal No.	Color of Wire	Signal Name [Specification]
9	B	GND
10	B	GND

JCAWA0152GB

HOW TO READ WIRING DIAGRAMS

< HOW TO USE THIS MANUAL >

Description				
Number	Item	Description		
1	Connector number	<ul style="list-style-type: none"> Alphabetic characters show to which harness the connector is placed. Numeric characters show the identification number of connectors. 		
2	Connector type	<ul style="list-style-type: none"> 1: Connector model 2: Cavity 3: Male (M) and female (F) terminals 4: Connector color 5: Special type <div style="border: 1px solid black; padding: 5px; margin-top: 10px;"> <p>Example:</p> </div>		
3	Terminal number	<ul style="list-style-type: none"> This means the terminal number of a connector. 		
4	Wire color	<ul style="list-style-type: none"> This shows a code for the color of the wire. <table style="width: 100%; border: none;"> <tr> <td style="width: 50%; border: none;"> B = Black W = White R = Red G = Green L = Blue Y = Yellow LG = Light Green BG or BE = Beige LA = Lavender </td> <td style="width: 50%; border: none;"> BR = Brown OR or O = Orange P = Pink PU or V (Violet) = Purple GY or GR = Gray SB = Sky Blue CH = Dark Brown DG = Dark Green </td> </tr> </table> <ul style="list-style-type: none"> When the wire color is striped, the base color is given first, followed by the stripe color as shown below: Example: L/W = Blue with White Stripe 	B = Black W = White R = Red G = Green L = Blue Y = Yellow LG = Light Green BG or BE = Beige LA = Lavender	BR = Brown OR or O = Orange P = Pink PU or V (Violet) = Purple GY or GR = Gray SB = Sky Blue CH = Dark Brown DG = Dark Green
B = Black W = White R = Red G = Green L = Blue Y = Yellow LG = Light Green BG or BE = Beige LA = Lavender	BR = Brown OR or O = Orange P = Pink PU or V (Violet) = Purple GY or GR = Gray SB = Sky Blue CH = Dark Brown DG = Dark Green			
5	Connector	<ul style="list-style-type: none"> This means the connector information. This unit-side is described by the connector symbols. 		

How to Repair Aluminum Wires

INFOID:000000010329754

PRECAUTIONS FOR THE HANDLING OF ALUMINUM WIRES

- If an aluminum wire is damaged (e.g. broken), never perform the repair method for copper wires (soldering).
- Never perform electrotap for connecting broken aluminum wires.
- To secure the wire fixing strength (a force to protect aluminum wire from being disconnected from crimp terminal) and electrical conductivity, always use the dedicated harness repair kit and caulking tool [SST: KV99112600] when repairing broken wires.

HOW TO DISTINGUISH ALUMINUM WIRES

Wiring color: Lavender (Color code: LA)

HOW TO REPAIR BROKEN WIRES

- Insert heat shrinkable tube (2) into the target aluminum wire (1) beforehand.
- Strip wire terminal approximately 10 mm and insert it into crimp terminal (3).

CAUTION:

Check wire size and use appropriate crimp terminal.

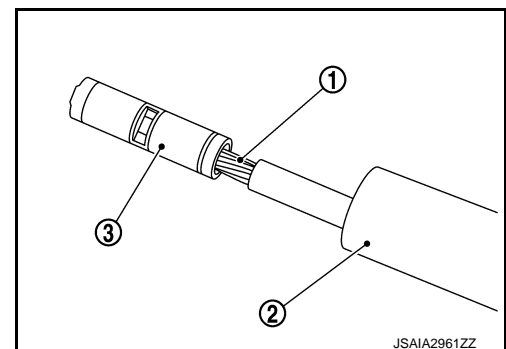

HOW TO READ WIRING DIAGRAMS

< HOW TO USE THIS MANUAL >

3. Set crimp terminal to the die (tooth) of caulking tool [SST: KV99112600].
CAUTION:
Use appropriate die (tooth) of caulking tool [SST: KV99112600] according to the crimp terminal size.

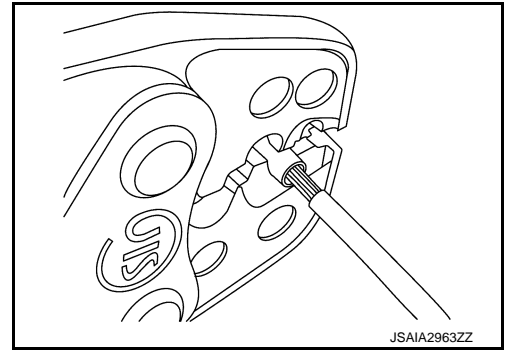

4. Apply load until the handle of caulking tool [SST: KV99112600] is released.
NOTE:
The handle of the specified caulking tool [SST: KV99112600] is not opened until crimping is completed.

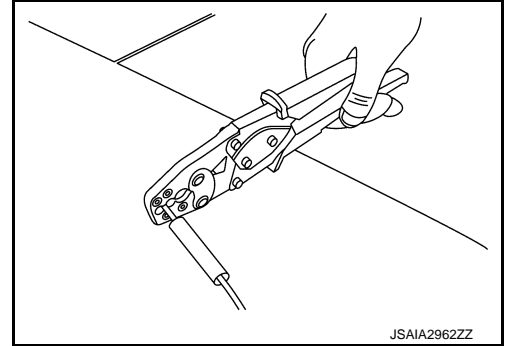

5. After crimping both sides, pull wire at both ends to check that they are not disconnected from crimp terminals.

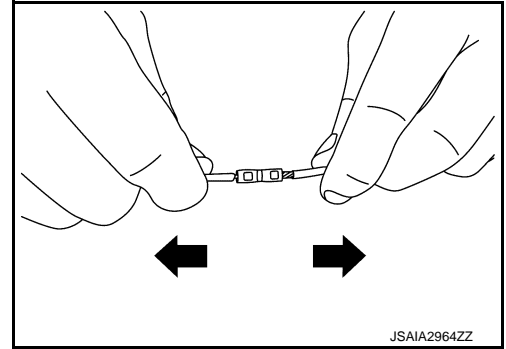

6. Cover the crimp terminal with heat shrinkable tube (1) and heat the tube with industrial dryer (A).

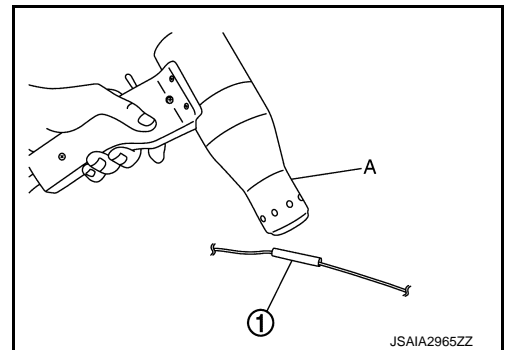

7. After heating heat shrinkable tube (1), check that adhesive (A) is squeezed out from both ends of tube to the entire perimeter.

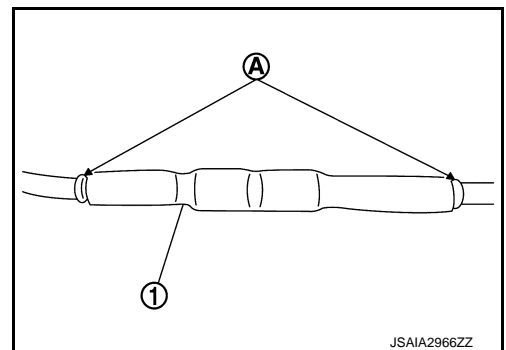

HOW TO READ WIRING DIAGRAMS

< HOW TO USE THIS MANUAL >

8. Wind insulating tape (A) around heat shrinkable tube for the purpose of waterproof and anticorrosion.

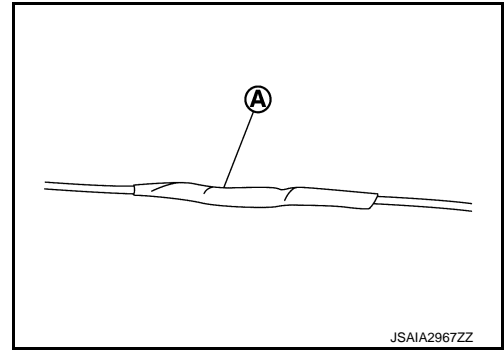

HOW TO EXTEND WIRES

When repairing a broken aluminum wire, it can be extended by connecting aluminum wire (2) with copper wire (3) by using crimp terminal (1).

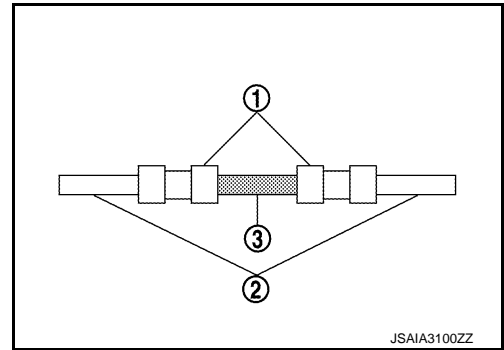

GI

B

C

D

E

F

G

H

I

J

K

L

M

N

O

P

ABBREVIATIONS

< HOW TO USE THIS MANUAL >

ABBREVIATIONS

Abbreviation List

INFOID:00000009754825

The following **ABBREVIATIONS** are used:

A

ABBREVIATION	DESCRIPTION
A/C	Air conditioner
A/C	Air conditioning
A/F sensor	Air fuel ratio sensor
A/T	Automatic transaxle/transmission
ABS	Anti-lock braking system
ACCS	Advance climate control system
ACL	Air cleaner
AP	Accelerator pedal
APP	Accelerator pedal position
ATF	Automatic transmission fluid
AV	Audio visual
AWD	All wheel drive

B

ABBREVIATION	DESCRIPTION
BARO	Barometric pressure
BCI	Back-up collision intervention
BCM	Body control module
BLSD	Brake limited slip differential
BPP	Brake pedal position
BSW	Blind spot warning

C

ABBREVIATION	DESCRIPTION
CKP	Crankshaft position
CL	Closed loop
CMP	Camshaft position
CPP	Clutch pedal position
CTP	Closed throttle position
CVT	Continuously variable transaxle/transmission

D

ABBREVIATION	DESCRIPTION
D1	Drive range first gear
D2	Drive range second gear
D3	Drive range third gear
D4	Drive range fourth gear
DCA	Distance control assist
DDS	Downhill drive support
DFI	Direct fuel injection system
DLC	Data link connector
DTC	Diagnostic trouble code

ABBREVIATIONS

< HOW TO USE THIS MANUAL >

E		
ABBREVIATION	DESCRIPTION	
E/T	Exhaust temperature	GI
EBD	Electric brake force distribution	
EC	Engine control	B
ECL	Engine coolant level	
ECM	Engine control module	C
ECT	Engine coolant temperature	
ECV	Electrical control valve	
EEPROM	Electrically erasable programmable read only memory	D
EFT	Engine fuel temperature	
EGR	Exhaust gas recirculation	E
EGRT	Exhaust gas recirculation temperature	
EGT	Exhaust gas temperature	
EOP	Engine oil pressure	F
EP	Exhaust pressure	
EPR	Exhaust pressure regulator	G
EPS	Electronically controlled power steering	
ESP	Electronic stability program system	H
EVAP canister	Evaporative emission canister	
EVSE	Electric vehicle supply equipment	
EXC	Exhaust control	I

F		
ABBREVIATION	DESCRIPTION	
FC	Fan control	J
FCW	Forward collision warning	
FEB	Forward emergency braking	
FIC	Fuel injector control	K
FP	Fuel pump	
FR	Front	L
FRP	Fuel rail pressure	
FRT	Fuel rail temperature	
FTP	Fuel tank pressure	M
FTT	Fuel tank temperature	

G		
ABBREVIATION	DESCRIPTION	
GND	Ground	N
GPS	Global positioning system	O
GST	Generic scan tool	

H		
ABBREVIATION	DESCRIPTION	
HBMC	Hydraulic body-motion control system	P
HDD	Hard disk drive	
HO2S	Heated oxygen sensor	
HOC	Heated oxidation catalyst	
HPCM	Hybrid power train control module	

ABBREVIATIONS

< HOW TO USE THIS MANUAL >

I	
ABBREVIATION	DESCRIPTION
I/M	Inspection and maintenance
IA	Intake air
IAC	Idle air control
IAT	Intake air temperature
IBA	Intelligent brake assist
IC	Ignition control
ICC	Intelligent cruise control
ICM	Ignition control module
IPDM E/R	Intelligent power distribution module engine room
ISC	Idle speed control
ISS	Input shaft speed

K	
ABBREVIATION	DESCRIPTION
KS	Knock sensor

L	
ABBREVIATION	DESCRIPTION
LBC	Li-ion battery controller
LCD	Liquid crystal display
LCU	Local control unit
LDP	Lane departure prevention
LDW	Lane departure warning
LED	Light emitting diode
LH	Left-hand
LIN	Local interconnect network

M	
ABBREVIATION	DESCRIPTION
M/T	Manual transaxle/transmission
MAF	Mass airflow
MAP	Manifold absolute pressure
MDU	Multi display unit
MI	Malfunction indicator
MIL	Malfunction indicator lamp

N	
ABBREVIATION	DESCRIPTION
NOX	Nitrogen oxides

O	
ABBREVIATION	DESCRIPTION
O2	Oxygen
O2S	Oxygen sensor
OBD	On board diagnostic
OC	Oxidation catalytic converter
OD	Overdrive
OL	Open loop
OSS	Output shaft speed

ABBREVIATIONS

< HOW TO USE THIS MANUAL >

P		
ABBREVIATION	DESCRIPTION	
P/S	Power steering	GI
PBR	Potential balance resistor	
PCV	Positive crankcase ventilation	B
PFCW	Predictive forward collision warning	
PNP	Park/Neutral position	C
PSP	Power steering pressure	
PTC	Positive temperature coefficient	
PTO	Power takeoff	D
PWM	Pulse width modulation	
R		
ABBREVIATION	DESCRIPTION	
RAM	Random access memory	E
RAS	Rear active steer	F
RH	Right-hand	
ROM	Read only memory	G
RPM	Engine speed	
RR	Rear	
S		
ABBREVIATION	DESCRIPTION	
SAE	Society of Automotive Engineers, Inc.	H
SCK	Serial clock	I
SDS	Service Data and Specifications	
SRT	System readiness test	J
SST	Special Service Tools	
T		
ABBREVIATION	DESCRIPTION	
TC	Turbocharger	K
TCM	Transmission control module	
TCS	Traction control system	L
TCU	Telematics communication unit	
TP	Throttle position	M
TPMS	Tire pressure monitoring system	
TSS	Turbine shaft speed	
TWC	Three way catalytic converter	N
U		
ABBREVIATION	DESCRIPTION	
USS	Uphill start support	O
V		
ABBREVIATION	DESCRIPTION	
VCM	Vehicle control module	P
VDC	Vehicle dynamics control system	
VIN	Vehicle identification number	
VSS	Vehicle speed sensor	

ABBREVIATIONS

< HOW TO USE THIS MANUAL >

W

ABBREVIATION	DESCRIPTION
WOT	Wide open throttle

1

ABBREVIATION	DESCRIPTION
11	1st range first gear
12	1st range second gear
1GR	First gear

2

ABBREVIATION	DESCRIPTION
21	2nd range first gear
22	2nd range second gear
2GR	Second gear
2WD	2-wheel drive

3

ABBREVIATION	DESCRIPTION
3GR	Third gear

4

ABBREVIATION	DESCRIPTION
4GR	Fourth gear
4WAS	Four wheel active steer
4WD	Four wheel drive

5

ABBREVIATION	DESCRIPTION
5GR	Fifth gear

6

ABBREVIATION	DESCRIPTION
6GR	Sixth gear

7

ABBREVIATION	DESCRIPTION
7GR	Seventh gear

TIGHTENING TORQUE OF STANDARD BOLTS

< HOW TO USE THIS MANUAL >

TIGHTENING TORQUE OF STANDARD BOLTS

GI

Description

INFOID:000000009754826

This vehicle has both new standard based on ISO* and previous standard bolts/nuts. There are some differences between these two types of bolts/ nuts; shape of the head, grade of strength, hexagonal width across flats and the standard tightening torque.

- For guidance in discriminating, refer to [GI-21, "Tightening Torque Table \(New Standard Included\)"](#).
- The new standard machine screws and tapping screws have a head of ISO standard torx recess.
- If the tightening torque is not described in the description or figure, refer to [GI-21, "Tightening Torque Table \(New Standard Included\)"](#).

*ISO: International Organization for Standardization

Tightening Torque Table (New Standard Included)

INFOID:000000009754827

CAUTION:

- The special parts are excluded.
- The bolts/nuts in these tables have a strength (discrimination) number/symbol assigned to the head or the like. As to the relation between the strength grade in these tables and the strength (discrimination) number/symbol, refer to "DISCRIMINATION OF BOLTS AND NUTS".

PREVIOUS STANDARD

Grade (Strength grade)	Bolt size	Bolt di- ameter mm	Hexagonal width across flats mm	Pitch mm	Tightening torque (Without lubricant)							
					Hexagon head bolt				Hexagon flange bolt			
					N-m	kg-m	ft-lb	in-lb	N-m	kg-m	ft-lb	in-lb
4T	M6	6.0	10	1.0	5.5	0.56	4	49	7	0.71	5	62
	M8	8.0	12	1.25	13.5	1.4	10	—	17	1.7	13	—
				1.0	13.5	1.4	10	—	17	1.7	13	—
	M10	10.0	14	1.5	28	2.9	21	—	35	3.6	26	—
				1.25	28	2.9	21	—	35	3.6	26	—
	M12	12.0	17	1.75	45	4.6	33	—	55	5.6	41	—
1.25				45	4.6	33	—	65	6.6	48	—	
M14	14.0	19	1.5	80	8.2	59	—	100	10	74	—	
7T	M6	6.0	10	1.0	9	0.92	7	80	11	1.1	8	97
	M8	8.0	12	1.25	22	2.2	16	—	28	2.9	21	—
				1.0	22	2.2	16	—	28	2.9	21	—
	M10	10.0	14	1.5	45	4.6	33	—	55	5.6	41	—
				1.25	45	4.6	33	—	55	5.6	41	—
	M12	12.0	17	1.75	80	8.2	59	—	100	10	74	—
1.25				80	8.2	59	—	100	10	74	—	
M14	14.0	19	1.5	130	13	96	—	170	17	125	—	
9T	M6	6.0	10	1.0	11	1.1	8	—	13.5	1.4	10	—
	M8	8.0	12	1.25	28	2.9	21	—	35	3.6	26	—
				1.0	28	2.9	21	—	35	3.6	26	—
	M10	10.0	14	1.5	55	5.6	41	—	80	8.2	59	—
				1.25	55	5.6	41	—	80	8.2	59	—
	M12	12.0	17	1.75	100	10	74	—	130	13	96	—
1.25				100	10	74	—	130	13	96	—	
M14	14.0	19	1.5	170	17	125	—	210	21	155	—	

CAUTION:

TIGHTENING TORQUE OF STANDARD BOLTS

< HOW TO USE THIS MANUAL >

The parts with aluminum or the cast iron washer surface/thread surface are excluded.

NEW STANDARD BASED ON ISO

Grade (Strength grade)	Bolt size	Bolt di- ameter mm	Hexagonal width across flats mm	Pitch mm	Tightening torque							
					Hexagon head bolt				Hexagon flange bolt			
					N-m	kg-m	ft-lb	in-lb	N-m	kg-m	ft-lb	in-lb
4.8 (Without lubricant)	M6	6.0	10	1.0	5.5	0.56	4	49	7	0.71	5	62
	M8	8.0	13	1.25	13.5	1.4	10	—	17	1.7	13	—
				1.0	13.5	1.4	10	—	17	1.7	13	—
	M10	10.0	16	1.5	28	2.9	21	—	35	3.6	26	—
				1.25	28	2.9	21	—	35	3.6	26	—
	M12	12.0	18	1.75	45	4.6	33	—	55	5.6	41	—
1.25				45	4.6	33	—	65	6.6	48	—	
M14	14.0	21	1.5	80	8.2	59	—	100	10	74	—	
4.8 (With lu- bricant)	M6	6.0	10	1.0	4	0.41	3	35	5.5	0.56	4	49
	M8	8.0	13	1.25	11	1.1	8	—	13.5	1.4	10	—
				1.0	11	1.1	8	—	13.5	1.4	10	—
	M10	10.0	16	1.5	22	2.2	16	—	28	2.9	21	—
				1.25	22	2.2	16	—	28	2.9	21	—
	M12	12.0	18	1.75	35	3.6	26	—	45	4.6	33	—
1.25				35	3.6	26	—	45	4.6	33	—	
M14	14.0	21	1.5	65	6.6	48	—	80	8.2	59	—	
8.8 (With lu- bricant)	M6	6.0	10	1.0	8	0.82	6	71	10	1.0	7	89
	M8	8.0	13	1.25	21	2.1	15	—	25	2.6	18	—
				1.0	21	2.1	15	—	25	2.6	18	—
	M10	10.0	16	1.5	40	4.1	30	—	50	5.1	37	—
				1.25	40	4.1	30	—	50	5.1	37	—
	M12	12.0	18	1.75	70	7.1	52	—	85	8.7	63	—
1.25				70	7.1	52	—	85	8.7	63	—	
M14	14.0	21	1.5	120	12	89	—	140	14	103	—	
10.9 (With lu- bricant)	M6	6.0	10	1.0	10	1.0	7	89	12	1.2	9	106
	M8	8.0	13	1.25	27	2.8	20	—	32	3.3	24	—
				1.0	27	2.8	20	—	32	3.3	24	—
	M10	10.0	16	1.5	55	5.6	41	—	65	6.6	48	—
				1.25	55	5.6	41	—	65	6.6	48	—
	M12	12.0	18	1.75	95	9.7	70	—	110	11	81	—
1.25				95	9.7	70	—	110	11	81	—	
M14	14.0	21	1.5	160	16	118	—	180	18	133	—	

CAUTION:

1. Use tightening torque with lubricant for the new standard bolts/nuts in principle. Friction coefficient stabilizer is applied to the new standard bolts/nuts.
2. However, use tightening torque without lubricant for the following cases. Friction coefficient stabilizer is not applied to the following bolts/nuts.
 - Grade 4.8, M6 size bolt, Conical spring washer installed
 - Paint removing nut (Size M6 and M8) for fixing with weld bolt

TIGHTENING TORQUE OF STANDARD BOLTS

< HOW TO USE THIS MANUAL >

DISCRIMINATION OF BOLTS AND NUTS

GI

BOLTS

	Grade (Strength)	Discrimination	
Previous standard	4T (392N/mm ²)		 (No number/ symbol)
	7T (686N/mm ²)		
	9T (883N/mm ²)		
New Standard	4.8 (420N/mm ²)		 (No number/ symbol)
	8.8 (800N/mm ²)		
	10.9 (1040N/mm ²)		

NUTS

	Grade (Proof load stress)	Discrimination		
Previous standard	7N (686N/mm ²)	 (No number/ symbol)		
	9N (883N/mm ²)			
New Standard	8 (800N/mm ²)			 (No number/ symbol)
	10 (1040N/mm ²)			

NOTICE:

- A number is assigned on the side of the nuts in some cases.
- A number or symbol is assigned on the upper surface of the flange for the nut with flange.

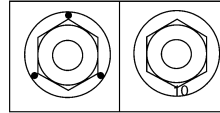

MACHINE SCREWS AND TAPPING SCREWS

Shape of the head :

Cross recess for the previous standard
Torx recess for the new standard

Screw size	Screw diameter	Torx size
M4	4.0	T20
M5	5.0	T20
M6	6.0	T30

NOTICE:

Use torx size T20 (united with M4 screw) for M5 screw although ISO standard specifies T25.

SAIA0453E

B

C

D

E

F

G

H

I

J

K

L

M

N

O

P

RECOMMENDED CHEMICAL PRODUCTS AND SEALANTS

< HOW TO USE THIS MANUAL >

RECOMMENDED CHEMICAL PRODUCTS AND SEALANTS

Recommended Chemical Products and Sealants

INFOID:000000009754828

Refer to the following chart for help in selecting the appropriate chemical product or sealant.

	Product Description	Purpose	Nissan North America Part No. (USA)	Nissan Canada Part No. (Canada)	Aftermarket Cross-reference Part Nos.
1	Rear View Mirror Adhesive	Used to permanently re-mount rear view mirrors to windows.	999MP-AM000P	99998-50505	Permatex 81844
2	Anaerobic Liquid Gasket	For metal-to-metal flange sealing. Can fill a 0.38 mm (0.015 inch) gap and provide instant sealing for most powertrain applications.	999MP-AM001P	99998-50503	Permatex 51813 and 51817
3	High Performance Thread Sealant	Provides instant sealing on any threaded straight or parallel threaded fitting. (Thread sealant only, no locking ability.) • Do not use on plastic.	999MP-AM002P	999MP-AM002P	Permatex 56521
4	Silicone RTV	Gasket Maker	999MP-AM003P (Ultra Grey)	99998-50506 (Ultra Grey)	Permatex Ultra Grey 82194; Three Bond 1207, 1215, 1216, 1217F, 1217G and 1217H Nissan RTV Part No. 999MP-A7007
		Gasket Maker for Maxima/Quest 5-speed automatic transmission (RE5F22A)	—	—	Three Bond 1281B or exact equivalent in its quality
5	High Temperature, High Strength Thread Locking Sealant (Red)	Threadlocker	999MP-AM004P	999MP-AM004P	Permatex 27200; Three Bond 1360, 1360N, 1305 N&P, 1307N, 1335, 1335B, 1363B, 1377C, 1386B, D&E and 1388 Loctite 648
6	Medium Strength Thread Locking Sealant (Blue)	Threadlocker (service tool removable)	999MP-AM005P	999MP-AM005P	Permatex 24200, 24206, 24240, 24283 and 09178; Three Bond 1322, 1322N, 1324 D&N, 1333D, 1361C, 1364D, 1370C and 1374

PRECAUTIONS

< PRECAUTION >

PRECAUTION

PRECAUTIONS

Description

INFOID:000000009754829

Observe the following precautions to ensure safe and proper servicing. These precautions are not described in each individual section.

Precaution for Supplemental Restraint System (SRS) "AIR BAG" and "SEAT BELT PRE-TENSIONER"

INFOID:000000009754830

The Supplemental Restraint System such as "AIR BAG" and "SEAT BELT PRE-TENSIONER", used along with a front seat belt, helps to reduce the risk or severity of injury to the driver and front passenger for certain types of collision. This system includes seat belt switch inputs and dual stage front air bag modules. The SRS system uses the seat belt switches to determine the front air bag deployment, and may only deploy one front air bag, depending on the severity of a collision and whether the front occupants are belted or unbelted. Information necessary to service the system safely is included in the "SRS AIR BAG" and "SEAT BELT" of this Service Manual.

WARNING:

Always observe the following items for preventing accidental activation.

- To avoid rendering the SRS inoperative, which could increase the risk of personal injury or death in the event of a collision that would result in air bag inflation, all maintenance must be performed by an authorized NISSAN/INFINITI dealer.
- Improper maintenance, including incorrect removal and installation of the SRS, can lead to personal injury caused by unintentional activation of the system. For removal of Spiral Cable and Air Bag Module, see "SRS AIR BAG".
- Never use electrical test equipment on any circuit related to the SRS unless instructed to in this Service Manual. SRS wiring harnesses can be identified by yellow and/or orange harnesses or harness connectors.

PRECAUTIONS WHEN USING POWER TOOLS (AIR OR ELECTRIC) AND HAMMERS

WARNING:

Always observe the following items for preventing accidental activation.

- When working near the Air Bag Diagnosis Sensor Unit or other Air Bag System sensors with the ignition ON or engine running, never use air or electric power tools or strike near the sensor(s) with a hammer. Heavy vibration could activate the sensor(s) and deploy the air bag(s), possibly causing serious injury.
- When using air or electric power tools or hammers, always switch the ignition OFF, disconnect the battery, and wait at least 3 minutes before performing any service.

Precaution for Procedure without Cowl Top Cover

INFOID:000000009754831

When performing the procedure after removing cowl top cover, cover the lower end of windshield with urethane, etc to prevent damage to windshield.

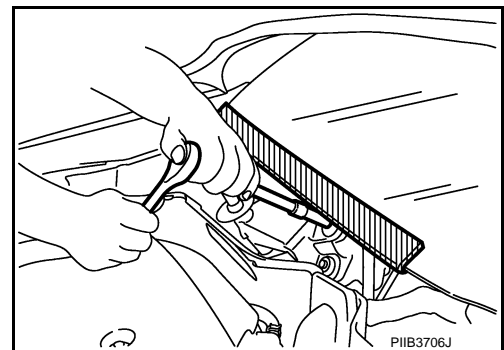

PRECAUTIONS

< PRECAUTION >

Precautions for Removing of Battery Terminal

INFOID:000000010097944

- When removing the 12V battery terminal, turn OFF the ignition switch and wait at least 30 seconds.

NOTE:

ECU may be active for several tens of seconds after the ignition switch is turned OFF. If the battery terminal is removed before ECU stops, then a DTC detection error or ECU data corruption may occur.

- For vehicles with the 2-batteries, be sure to connect the main battery and the sub battery before turning ON the ignition switch.

NOTE:

If the ignition switch is turned ON with any one of the terminals of main battery and sub battery disconnected, then DTC may be detected.

- After installing the 12V battery, always check "Self Diagnosis Result" of all ECUs and erase DTC.

NOTE:

The removal of 12V battery may cause a DTC detection error.

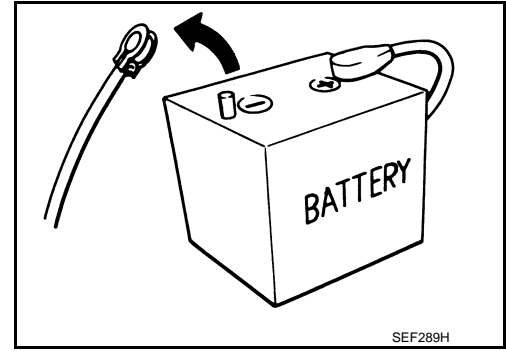

SEF289H

General Precautions

INFOID:000000009754832

- Do not operate the engine for an extended period of time without proper exhaust ventilation.
Keep the work area well ventilated and free of any inflammable materials. Special care should be taken when handling any inflammable or poisonous materials, such as gasoline, refrigerant gas, etc. When working in a pit or other enclosed area, be sure to properly ventilate the area before working with hazardous materials.
Do not smoke while working on the vehicle.

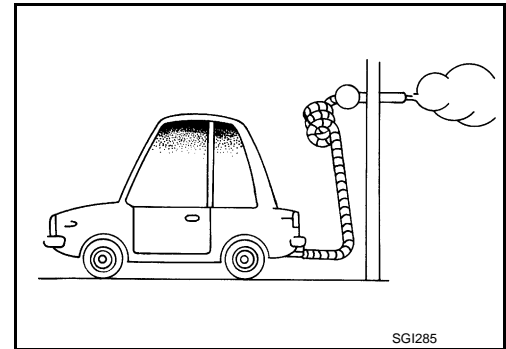

SGI285

- Before jacking up the vehicle, apply wheel chocks or other tire blocks to the wheels to prevent the vehicle from moving. After jacking up the vehicle, support the vehicle weight with safety stands at the points designated for proper lifting before working on the vehicle.
These operations should be done on a level surface.
- When removing a heavy component such as the engine or transaxle/transmission, be careful not to lose your balance and drop them. Also, do not allow them to strike adjacent parts, especially the brake tubes and master cylinder.

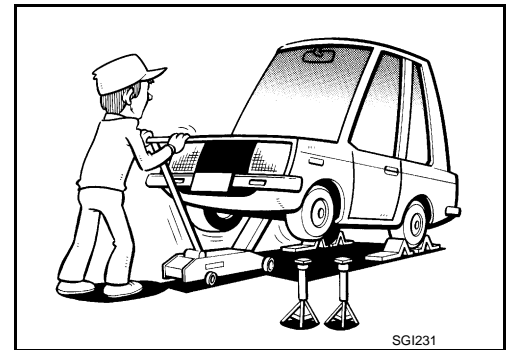

SGI231

- Before starting repairs which do not require battery power:
Turn off ignition switch.
Disconnect the negative battery terminal.
- If the battery terminals are disconnected, recorded memory of radio and each control unit is erased.
- For vehicles with two batteries, be sure to remove both batteries when instructed to remove 12V battery in the service manual. If specified as main battery or sub battery, then do as instructed.

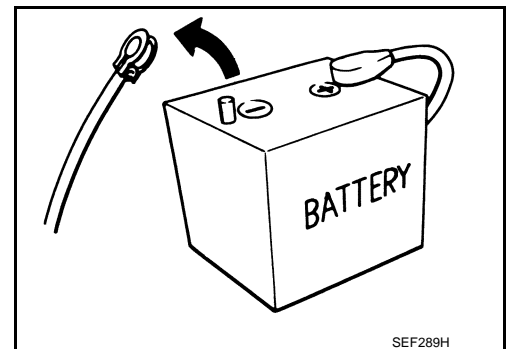

SEF289H

PRECAUTIONS

< PRECAUTION >

- To prevent serious burns:
Avoid contact with hot metal parts.
Do not remove the radiator cap when the engine is hot.
- Dispose of drained oil or the solvent used for cleaning parts in an appropriate manner.
- Do not attempt to top off the fuel tank after the fuel pump nozzle shuts off automatically.
Continued refueling may cause fuel overflow, resulting in fuel spray and possibly a fire.
- Clean all disassembled parts in the designated liquid or solvent prior to inspection or assembly.
- Replace oil seals, gaskets, packings, O-rings, locking washers, cotter pins, self-locking nuts, etc. with new ones.
- Replace inner and outer races of tapered roller bearings and needle bearings as a set.
- Arrange the disassembled parts in accordance with their assembled locations and sequence.
- Do not touch the terminals of electrical components which use microcomputers (such as ECM).
Static electricity may damage internal electronic components.
- After disconnecting vacuum or air hoses, attach a tag to indicate the proper connection.
- Use only the fluids and lubricants specified in this manual.
- Use approved bonding agent, sealants or their equivalents when required.
- Use hand tools, power tools (disassembly only) and recommended special tools where specified for safe and efficient service repairs.
- When repairing the fuel, oil, water, vacuum or exhaust systems, check all affected lines for leakage.

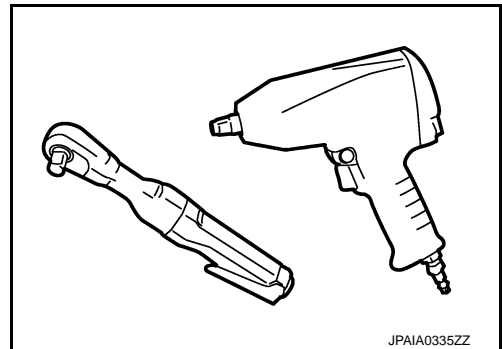

- Before servicing the vehicle:
Protect fenders, upholstery and carpeting with appropriate covers.
Take caution that keys, buckles or buttons do not scratch paint.

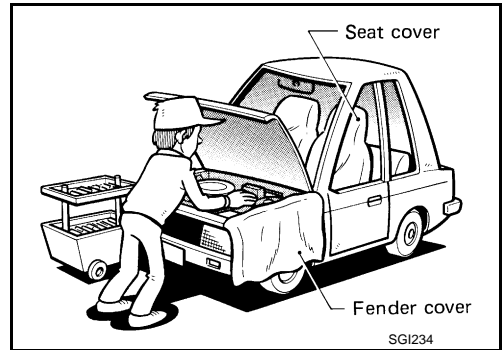

WARNING:

To prevent ECM from storing the diagnostic trouble codes, never carelessly disconnect the harness connectors which are related to the engine control system and TCM (transmission control module) system. The connectors should be disconnected only when working according to the WORK FLOW of TROUBLE DIAGNOSES in EC and TM sections.

Three Way Catalyst

INFOID:000000009754833

If a large amount of unburned fuel flows into the catalyst, the catalyst temperature will be excessively high. To prevent this, follow the instructions.

- Use unleaded gasoline only. Leaded gasoline will seriously damage the three way catalyst.
- When checking for ignition spark or measuring engine compression, make tests quickly and only when necessary.
- Do not run engine when the fuel tank level is low, otherwise the engine may misfire, causing damage to the catalyst.

PRECAUTIONS

< PRECAUTION >

Do not place the vehicle on flammable material. Keep flammable material off the exhaust pipe and the three way catalyst.

Multiport Fuel Injection System or Engine Control System

INFOID:000000009754834

- Before connecting or disconnecting any harness connector for the multiport fuel injection system or ECM:
Turn ignition switch to "OFF" position.
Disconnect negative battery terminal.
Otherwise, there may be damage to ECM.
- Before disconnecting pressurized fuel line from fuel pump to injectors, be sure to release fuel pressure.
- Be careful not to jar components such as ECM and mass air flow sensor.

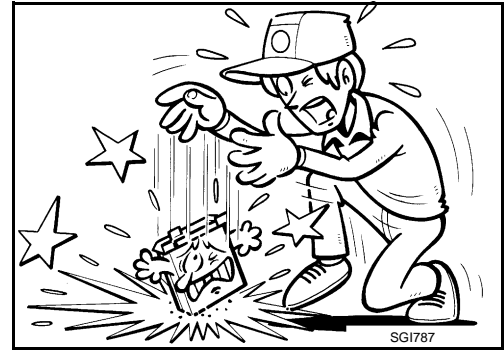

Precaution for Turbocharger

INFOID:000000009754835

The turbocharger turbine revolves at extremely high speeds and becomes very hot. Therefore, it is essential to maintain a clean supply of oil flowing through the turbocharger and to follow all required maintenance instructions and operating procedures.

- Always use the recommended oil. Follow the instructions for proper time to change the oil and proper oil level.
- Avoid accelerating engine to a high rpm immediately after starting.
- If engine had been operating at high rpm for an extended period of time, let it idle for a few minutes prior to shutting it off.

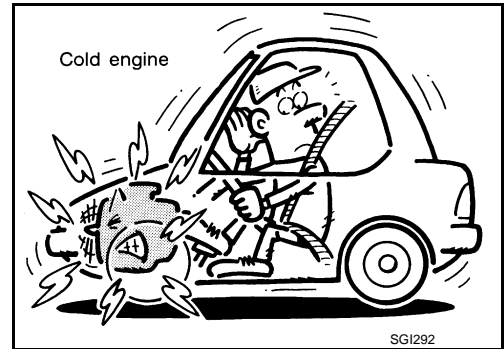

Hoses

INFOID:000000009754836

HOSE REMOVAL AND INSTALLATION

- To prevent damage to rubber hose, do not pry off rubber hose with tapered tool or screwdriver.

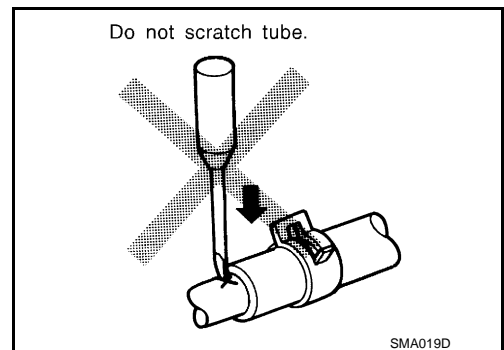

- To reinstall the rubber hose securely, check that hose insertion length and orientation is correct. (If tube is equipped with hose stopper, insert rubber hose into tube until it butts up against hose stopper.)

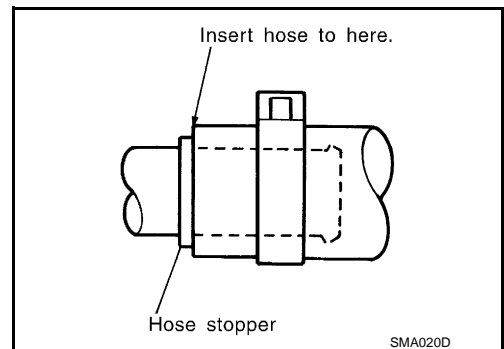

HOSE CLAMPING

PRECAUTIONS

< PRECAUTION >

- If old rubber hose is re-used, install hose clamp in its original position (at the indentation where the old clamp was). If there is a trace of tube bulging left on the old rubber hose, align rubber hose at that position.
- Discard old clamps; replace with new ones.

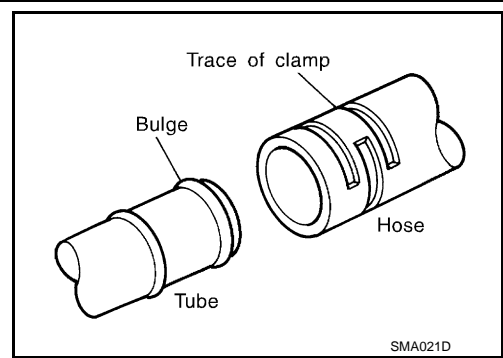

- After installing plate clamps, apply force to them in the direction of the arrow, tightening rubber hose equally all around.

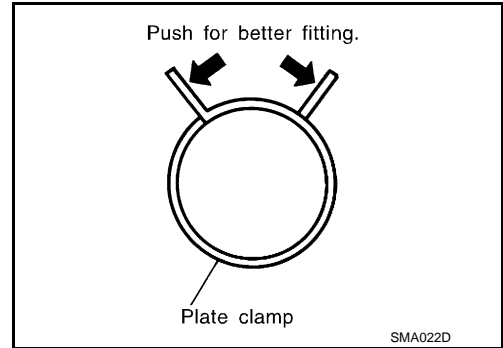

Engine Oils

INFOID:000000009754837

Prolonged and repeated contact with used engine oil may cause skin cancer. Try to avoid direct skin contact with used oil.

If skin contact is made, wash thoroughly with soap or hand cleaner as soon as possible.

HEALTH PROTECTION PRECAUTIONS

- Avoid prolonged and repeated contact with oils, particularly used engine oils.
- Wear protective clothing, including impervious gloves where practicable.
- Do not put oily rags in pockets.
- Avoid contaminating clothes, particularly underpants, with oil.
- Heavily soiled clothing and oil-impregnated footwear should not be worn. Overalls must be cleaned regularly.
- First aid treatment should be obtained immediately for open cuts and wounds.
- Use barrier creams, applying them before each work period, to help the removal of oil from the skin.
- Wash with soap and water to ensure all oil is removed (skin cleansers and nail brushes will help). Preparations containing lanolin replace the natural skin oils which have been removed.
- Do not use gasoline, kerosene, diesel fuel, gas oil, thinners or solvents for cleaning skin.
- If skin disorders develop, obtain medical advice without delay.
- Where practical, degrease components prior to handling.
- Where there is a risk of eye contact, eye protection should be worn, for example, chemical goggles or face shields; in addition an eye wash facility should be provided.

ENVIRONMENTAL PROTECTION PRECAUTIONS

Dispose of used oil and used oil filters through authorized waste disposal contractors to licensed waste disposal sites, or to the waste oil reclamation trade. If in doubt, contact the local authority for advice on disposal facilities.

It is illegal to pour used oil on to the ground, down sewers or drains, or into water sources.

The regulations concerning pollution vary between regions.

Air Conditioning

INFOID:000000009754838

Use an approved refrigerant recovery unit any time the air conditioning system must be discharged. Refer to HA section "REFRIGERANT" for specific instructions.

PRECAUTIONS

< PRECAUTION >

Fuel

INFOID:000000009754839

NISSAN recommends the use of unleaded premium gasoline with an octane rating of at least 91 AKI (Anti-Knock Index) number (Research octane number 96).

If unleaded premium gasoline is not available, may use unleaded regular gasoline with an octane rating of at least 87 AKI number (Research octane number 91), can be used. In such case, engine performance may be decrease.

CAUTION:

- **Using a fuel other than that specified could adversely affect the emission control system, and may also affect warranty coverage.**
- **Under no circumstances should a leaded gasoline be used, because this will damage the three-way catalyst.**
- **Do not use E-15 or E-85 fuel in the vehicle. The vehicle is not designed to run on E-15 or E-85 fuel. Using E-15 or E-85 fuel in a vehicle not specifically designed for E-15 or E-85 fuel can adversely affect the emission control devices and systems of the vehicle. Damage caused by such fuel is not covered by the NISSAN new vehicle limited warranty.**
- **U.S. government regulations require ethanol dispensing pumps to be identified by a small, square, orange and black label with the common abbreviation or the appropriate percentage for that region.**

LIFTING POINT

< PRECAUTION >

LIFTING POINT

Commercial Service Tools

INFOID:000000009754840

GI

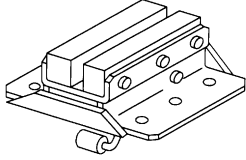
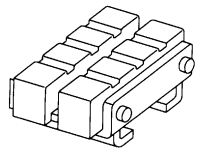
Tool name	Description
Board on attachment	 <p style="text-align: right;">S-NT001</p>
Safety stand attachment	 <p style="text-align: right;">S-NT002</p>

B

C

D

E

F

G

CAUTION:

- Every time the vehicle is lifted up, maintain the complete vehicle curb condition.
- Since the vehicle's center of gravity changes when removing main parts on the front side (engine, transmission, suspension etc.), support a jack up point on the rear side garage jack with a mission jack or equivalent.
- Since the vehicle's center of gravity changes when removing main parts on the rear side (rear axle, suspension, etc.), support a jack up point on the front side garage jack with a mission jack or equivalent.
- Be careful not to smash or never do anything that would affect piping parts.

H

I

J

Garage Jack and Safety Stand and 2-Pole Lift

INFOID:000000009754841

WARNING:

- Park the vehicle on a level surface when using the jack. Check to avoid damaging pipes, tubes, etc. under the vehicle.
- Never get under the vehicle while it is supported only by the jack. Always use safety stands when you have to get under the vehicle.
- Place wheel chocks at both front and back of the wheels on the ground.
- When lifting the vehicle, open the lift arms as wide as possible and ensure that the front and rear of the vehicle are well balanced.
- When setting the lift arm, never allow the arm to contact the brake tubes, brake cable, fuel lines and sill spoiler.

K

L

M

N

O

P

LIFTING POINT

< PRECAUTION >

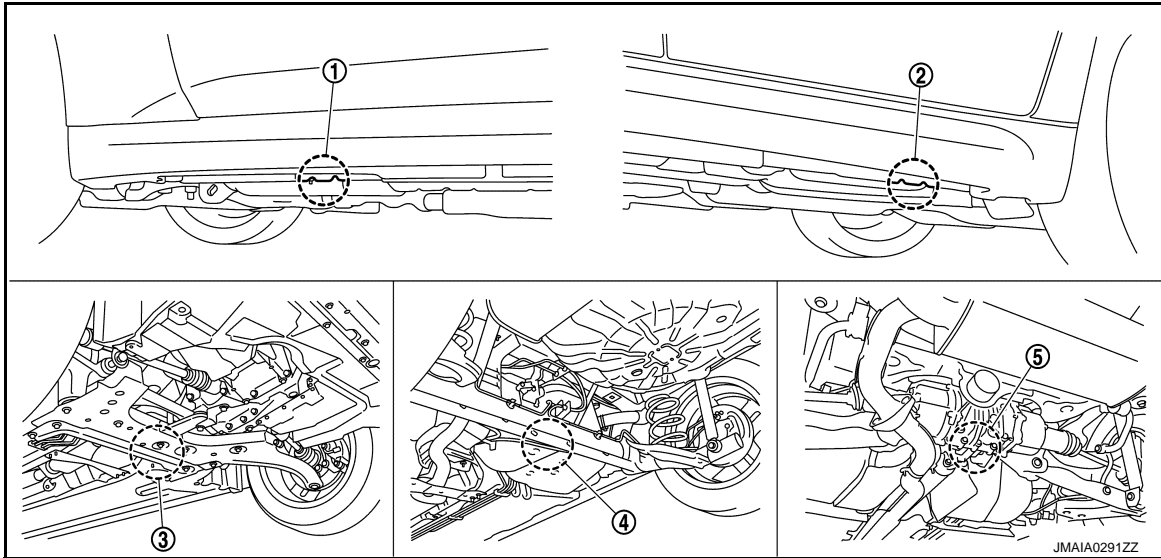

1. Safety stand point and lift up point (front)
2. Safety stand point and lift up point (rear)
3. Garage jack point (front)
4. Garage jack point (rear) (2WD)
5. Garage jack point (rear) (AWD)

CAUTION:

There is canister just behind Garage jack point rear. Jack up carefully.

Board-On Lift

INFOID:000000009754842

CAUTION:

Check vehicle is empty when lifting.

- The board-on lift attachment (A) set at front end of vehicle should be set on the front of the sill under the front door opening.
- Position attachments at front and rear ends of board-on lift.

← : Vehicle front

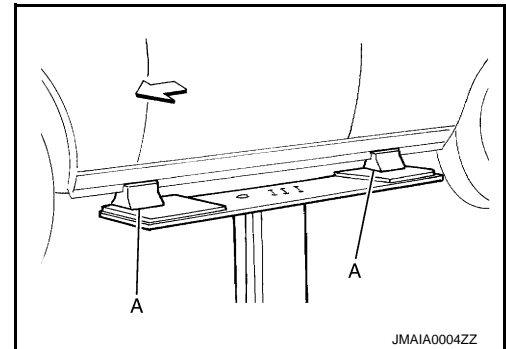

JMAIA0004ZZ

TOW TRUCK TOWING

< PRECAUTION >

TOW TRUCK TOWING

GI

Tow Truck Towing

INFOID:000000009754843

CAUTION:

- All applicable state or Provincial (in Canada) laws and local laws regarding the towing operation must be obeyed.
- It is necessary to use proper towing equipment to avoid possible damage to the vehicle during towing operation. Towing is in accordance with Towing Procedure Manual at dealer.
- Always attach safety chains before towing.
- When towing, check that the transmission, steering system and powertrain are in good order. If any unit is damaged, dollies must be used.
- Never tow a CVT model from the rear (that is backward) with four wheels on the ground. This may cause serious and expensive damage to the transmission.

2WD MODELS

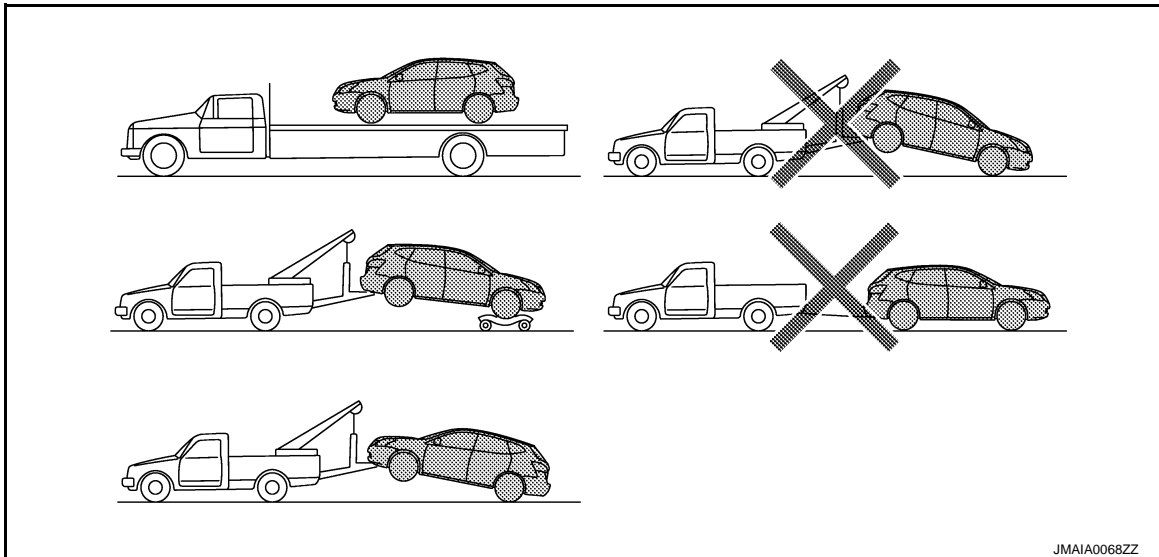

NISSAN recommends that vehicle be towed with the driving (front) wheels off the ground or that a dolly be used as illustrated.

CAUTION:

- Never tow CVT models with the front wheels on the ground or four wheels on the ground (forward or backward), as this may cause serious and expensive damage to the transmission.
If it is necessary to tow the vehicle with the rear wheels raised, always use towing dollies under the front wheels.
- When towing CVT models with the front wheels on towing dollies:
 - Turn the ignition switch to the OFF position, and secure the steering wheel in a straight ahead position with a rope or similar device. Never secure the steering wheel by turning the ignition switch to the LOCK position. This may damage the steering lock mechanism.
 - Move the selector lever to the N (Neutral) position.
- When the battery of vehicle equipped with the Intelligent Key system is discharged, your vehicle should be towed with the front wheels on towing dollies or place the vehicle on a flat bed truck.
- When towing two wheel drive CVT model with the rear wheels on the ground (if you do not use towing dollies): Always release the parking brake.

B

C

D

E

F

G

H

I

J

K

L

M

N

O

P

TOW TRUCK TOWING

< PRECAUTION >

AWD MODELS

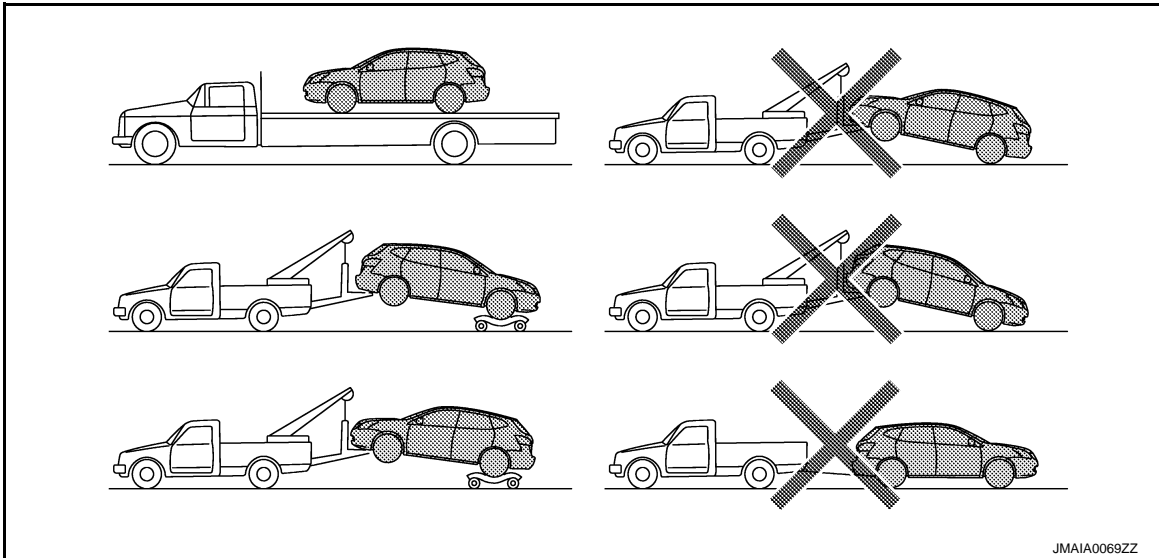

NISSAN recommends that a dolly be used as illustrated when towing AWD models.

CAUTION:

Never tow AWD models with any of the wheels on the ground as this may cause serious and expensive damage to the powertrain.

Vehicle Recovery (Freeing a Stuck Vehicle)

INFOID:000000009754844

FRONT

Securely install the vehicle recovery hook stored with jacking tools. Check that the hook is properly secured in the stored place after use.

WARNING:

- Stand clear of a stuck vehicle.
- Never spin your tires at high speed. This could cause them to explode and result in serious injury. Parts of your vehicle could also overheat and be damaged.

CAUTION:

- Tow chains or cables must be attached only to the vehicle recovery hooks or main structural members of the vehicle. Otherwise, the vehicle body will be damaged.
- Never use the vehicle tie downs to free a vehicle stuck in sand, snow, mud, etc. Never tow the vehicle using the vehicle tie downs or recovery hooks.
- Always pull the cable straight out from the front of the vehicle. Never pull on the hook at an angle.
- Pulling devices should be routed so they never touch any part of the suspension, steering, brake or cooling systems.
- Pulling devices such as ropes or canvas straps are not recommended for use in vehicle towing or recovery.

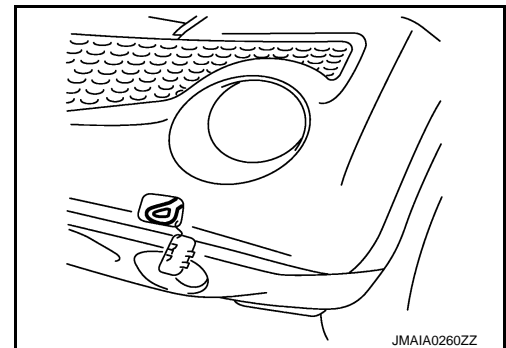

REAR

Securely install the vehicle recovery hook stored with jacking tools.

- 2WD



TOW TRUCK TOWING

< PRECAUTION >

- AWD

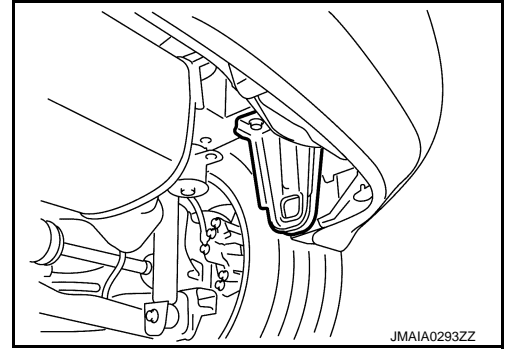

GI

B

C

D

E

F

G

H

I

J

K

L

M

N

O

P

PREPARATION

< PREPARATION >

PREPARATION

PREPARATION

Special Service Tools

INFOID:0000000010329755

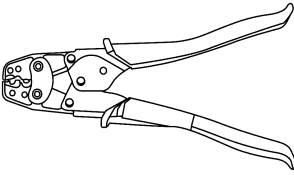
Tool number Tool name	Description
KV99112600 Caulking tool	Crimping terminals
 <p style="font-size: small; margin-top: 5px;">JSAIA2959ZZ</p>	

Commercial Service Tools

INFOID:0000000010329756

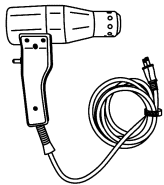
Tool name	Description
Industrial dryer	Heating heat shrinkable tube
 <p style="font-size: small; margin-top: 5px;">JSAIA3281ZZ</p>	

Repair Parts

INFOID:0000000010329757

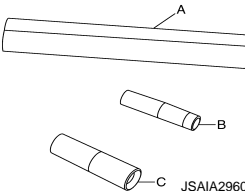
Part name	Description
Harness repair kit A: Heat shrinkable tube B: Crimp terminal (For harness with the diameter of 1.00 or less) C: Crimp terminal (For harness with the diameter of 1.25 or more)	Connecting aluminum wires
 <p style="font-size: small; margin-top: 5px;">JSAIA2960ZZ</p>	

IDENTIFICATION INFORMATION

< VEHICLE INFORMATION >

VEHICLE INFORMATION

IDENTIFICATION INFORMATION

Model Variation

INFOID:000000009754845

Destination	Body	Engine	Axle	Handle	Transmission	Grade	Model				
USA (Except for California)	4-door Hatchback	MR16DDT	2WD	LHD	6MT	SV	FDPALUY-UUA				
						SL	FDPALVY-UUA				
						NISMO	FDPALWY-UUA				
					M-CVT	S	FDPALRW-UUA				
						SV	FDPALUW-UUA				
						SL	FDPALVW-UUA				
			S			FDPNLRW-UUA					
			SV			FDPNLUW-UUA					
			SL			FDPNLVW-UUA					
			NISMO		FDPNLWW-UUA						
			California		4-door Hatchback	MR16DDT	2WD	LHD	6MT	SV	FDPALUY-UVA
										SL	FDPALVY-UVA
NISMO	FDPALWY-UVA										
M-CVT	S	FDPALRW-UVA									
	SV	FDPALUW-UVA									
	SL	FDPALVW-UVA									
	S	FDPNLRW-UVA									
	SV	FDPNLUW-UVA									
	SL	FDPNLVW-UVA									
NISMO	FDPNLWW-UVA										
Canada	4-door Hatchback	MR16DDT		2WD			LHD		6MT	S	FDPALRY-UNA
										SV	FDPALUY-UNA
			NISMO		FDPALWY-UNA						
			M-CVT	S	FDPALRW-UNA						
				SV	FDPALUW-UNA						
				S	FDPNLRW-UNA						
				SV	FDPNLUW-UNA						
				S	FDPNLRW-UNA						
				NISMO	FDPNLWW-UNA						

GI

B

C

D

E

F

G

H

I

J

K

L

M

N

O

P

IDENTIFICATION INFORMATION

< VEHICLE INFORMATION >

Model variation code (Prefix and suffix designations)

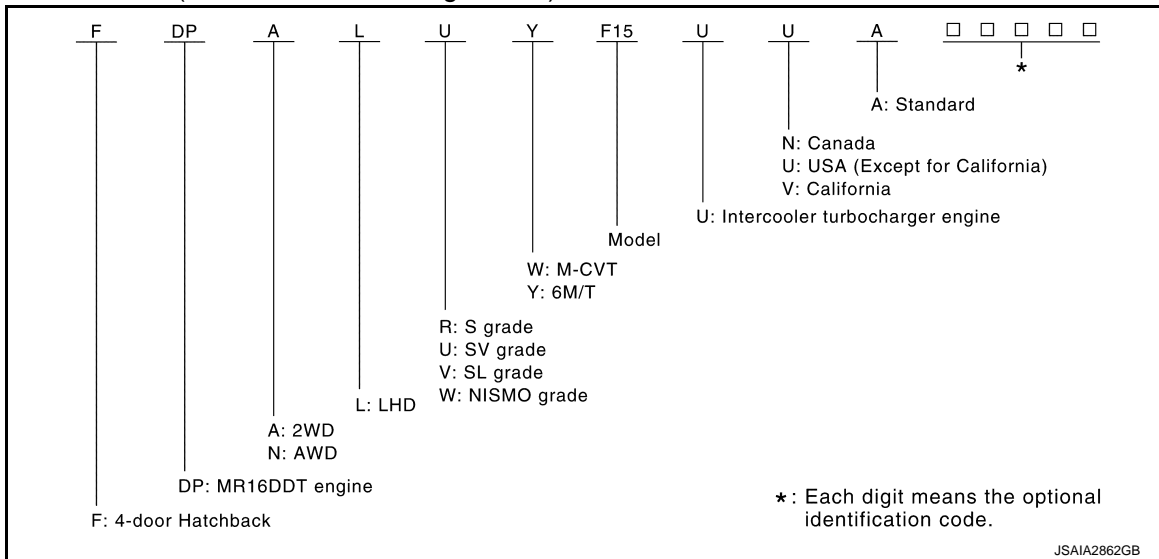

Information About Identification or Model Code

INFOID:000000009754846

IDENTIFICATION NUMBER

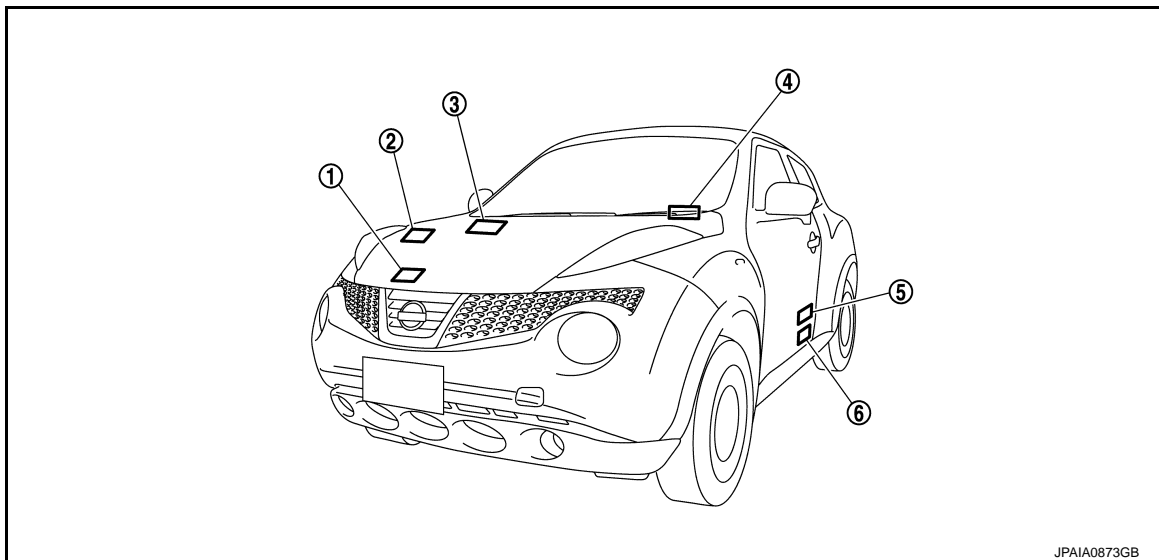

- | | | |
|--|--|---|
| 1. Air conditioner specification label | 2. Emission control information label | 3. Vehicle identification number (Chassis number) |
| 4. Vehicle identification number plate | 5. FMVSS certification label (For USA)
CMVSS certification label (For Canada) | 6. Tire and loading information label |

IDENTIFICATION INFORMATION

< VEHICLE INFORMATION >

VEHICLE IDENTIFICATION NUMBER ARRANGEMENT

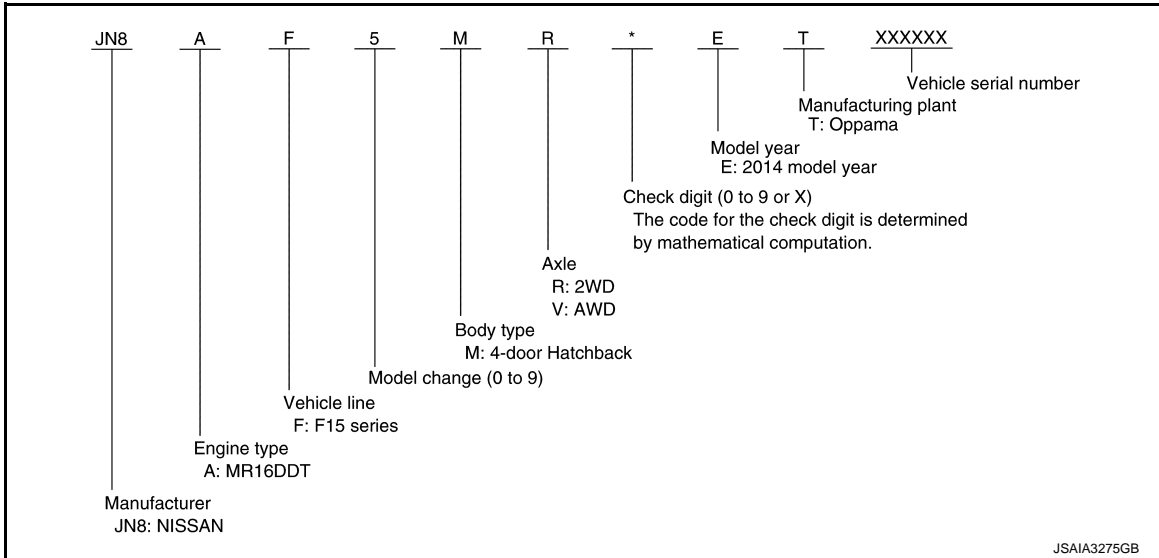

CERTIFICATION LABEL

FMVSS certification label

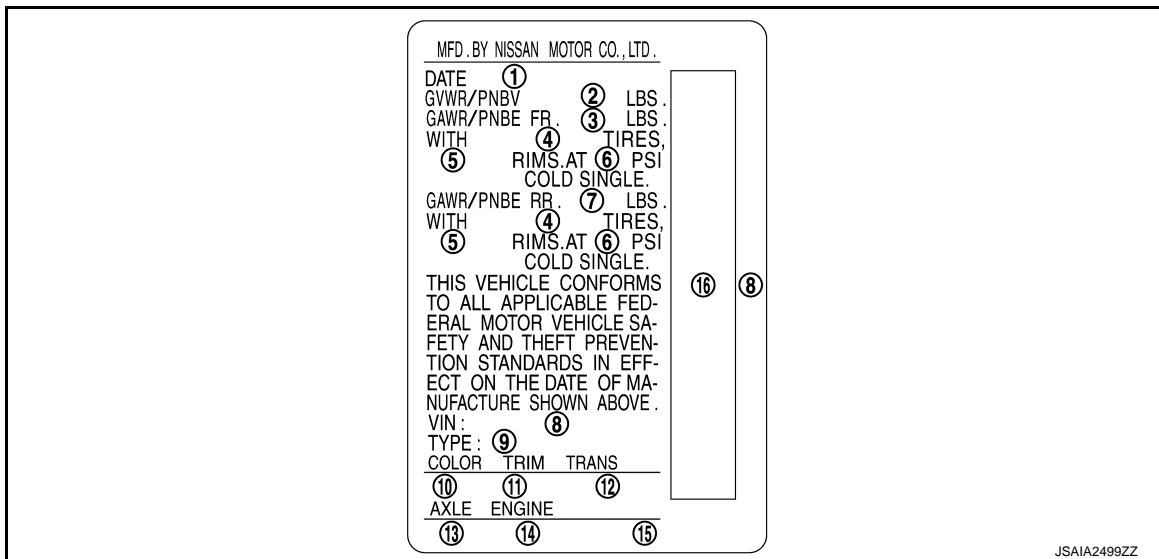

- | | | |
|------------------------------------|----------------------------------|-------------------------------------|
| 1. MFR Month / Year | 2. Gross vehicle weight rating | 3. Gross axle weight rating (Front) |
| 4. Tire size | 5. Wheel size | 6. Tire inflation pressure |
| 7. Gross axle weight rating (Rear) | 8. Vehicle identification number | 9. Verification model code |
| 10. Body color number | 11. Trim color number | 12. Transmission type |
| 13. Axle type | 14. Engine type | 15. Engine displacement |
| 16. VIN bar code | | |

CMVSS certification label

GI
B
C
D
E
F
G
H
I
J
K
L
M
N
O
P

IDENTIFICATION INFORMATION

< VEHICLE INFORMATION >

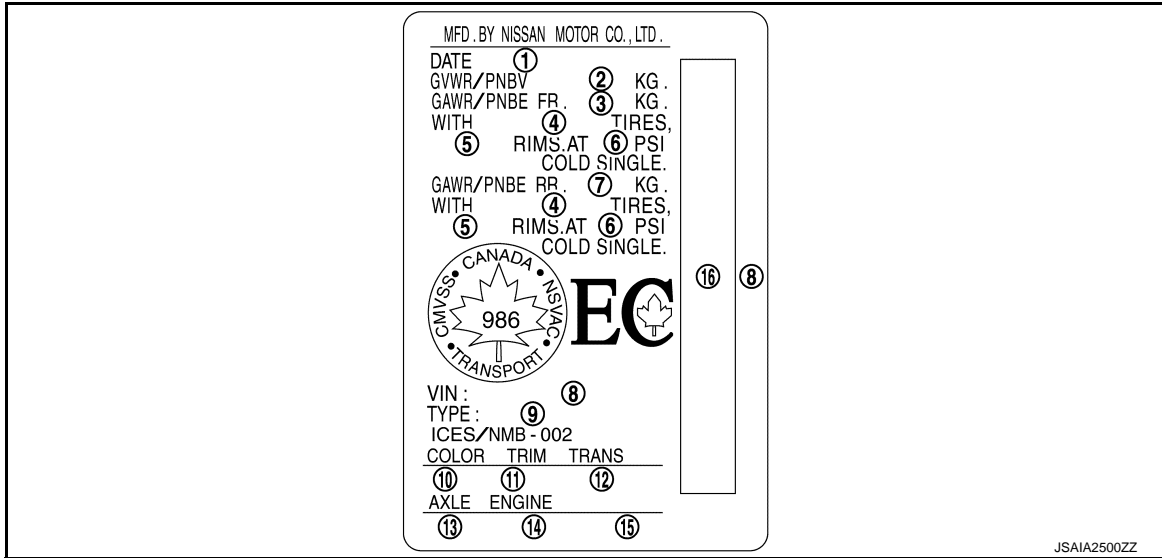

- | | | |
|------------------------------------|----------------------------------|-------------------------------------|
| 1. MFR Month / Year | 2. Gross vehicle weight rating | 3. Gross axle weight rating (Front) |
| 4. Tire size | 5. Wheel size | 6. Tire inflation pressure |
| 7. Gross axle weight rating (Rear) | 8. Vehicle identification number | 9. Verification model code |
| 10. Body color number | 11. Trim color number | 12. Transmission type |
| 13. Axle type | 14. Engine type | 15. Engine displacement |
| 16. VIN bar code | | |

ENGINE SERIAL NUMBER

⇐ : Vehicle front

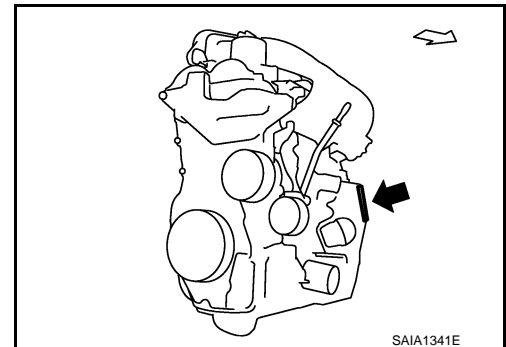

CVT NUMBER

⇐ : Vehicle front

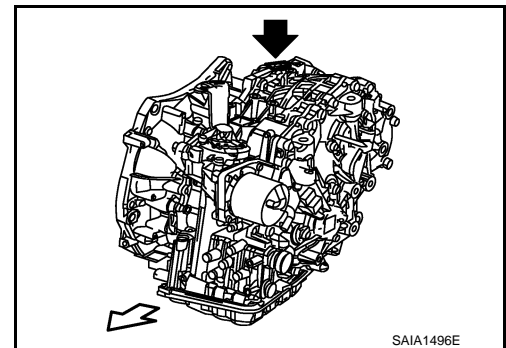

MANUAL TRANSAXLE NUMBER

IDENTIFICATION INFORMATION

< VEHICLE INFORMATION >

← : Vehicle front

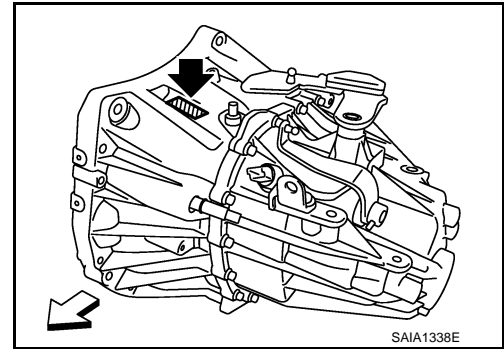

Dimensions

INFOID:000000009754847

Unit: mm (in)

Overall length	4,135 (162.8) ^{*1}
	4,125 (162.4) ^{*2}
	4,165 (164.0) ^{*3}
	4,160 (163.8) ^{*4}
Overall width	1,765 (69.5)
	1,770 (69.7) ^{*5}
Overall height	1,570 (61.8)
Front tread	1,525 (60.0)
Rear tread	1,525 (60.0) ^{*6}
	1,505 (59.3) ^{*7}
Wheelbase	2,530 (99.6)

*1: With front license plate bracket

*2: Without front license plate bracket

*3: With front license plate bracket (NISMO models)

*4: Without front license plate bracket (NISMO models)

*5: NISMO models

*6: 2WD models

*7: AWD models

Wheels & Tires

INFOID:000000009754848

Conventional	17 inch	Tire	P215/55R17 93V	
		Road wheel (Aluminum)	Size	17 × 7J
			Inset	47 mm (1.85 in)
	18 inch	Tire	225/45R18 95Y	
		Road wheel (Aluminum)	Size	18 × 7J
			Inset	47 mm (1.85 in)
Spare	Tire		T135/80D16 101M ^{*1}	
			T135/90D16 102M ^{*2}	
	Road wheel (Steel)	Size	16 × 4T	
		Inset	30 mm (1.18 in)	

*1: 2WD models

*2: AWD models

SERVICE INFORMATION FOR ELECTRICAL INCIDENT

< BASIC INSPECTION >

BASIC INSPECTION

SERVICE INFORMATION FOR ELECTRICAL INCIDENT

Work Flow

INFOID:000000009754849

WORK FLOW

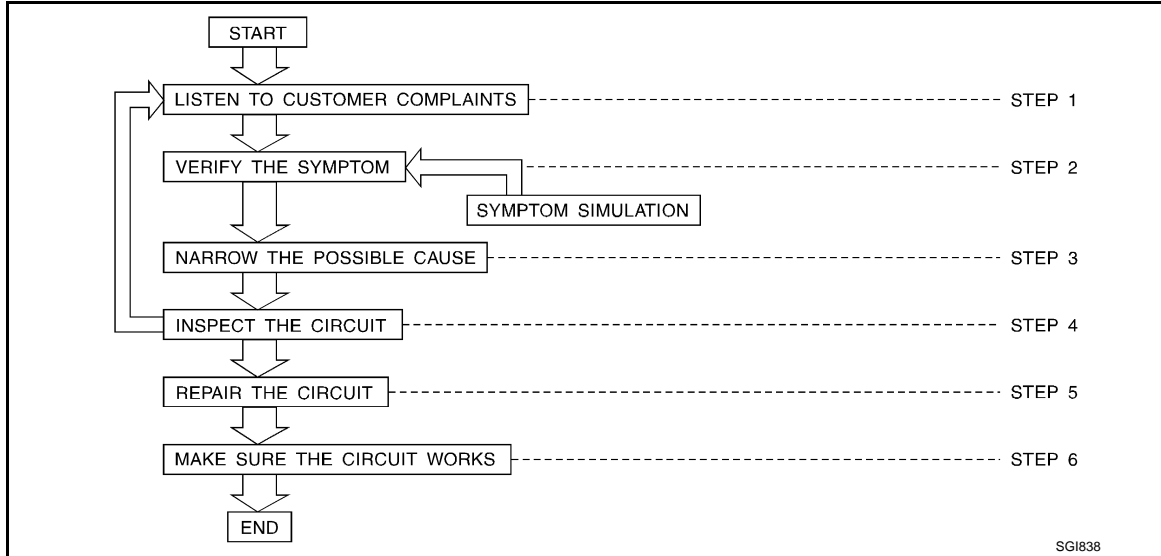

STEP	DESCRIPTION	
STEP 1	Get detailed information about the conditions and the environment when the incident occurred. The following are key pieces of information required to make a good analysis:	
	WHAT	Vehicle Model, Engine, Transmission/Transaxle and the System (i.e. Radio).
	WHEN	Date, Time of Day, Weather Conditions, Frequency.
	WHERE	Road Conditions, Altitude and Traffic Situation.
STEP 1	HOW	System Symptoms, Operating Conditions (Other Components Interaction). Service History and if any After Market Accessories have been installed.
	STEP 2: Operate the system, road test if necessary. Verify the parameter of the incident. If the problem cannot be duplicated, refer to "Incident Simulation Tests".	
STEP 3	Get the proper diagnosis materials together including:	
	<ul style="list-style-type: none"> • Power Supply Routing • System Operation Descriptions • Applicable Service Manual Sections • Check for any Service Bulletins Identify where to begin diagnosis based upon your knowledge of the system operation and the customer comments.	
STEP 4	Inspect the system for mechanical binding, loose connectors or wiring damage. Determine which circuits and components are involved and diagnose using the Power Supply Routing and Harness Layouts.	
STEP 5	Repair or replace the incident circuit or component.	
STEP 6	Operate the system in all modes. Verify the system works properly under all conditions. Check you have not inadvertently created a new incident during your diagnosis or repair steps.	

Control Units and Electrical Parts

INFOID:000000009754850

PRECAUTIONS

- Never reverse polarity of battery terminals.
- Install only parts specified for a vehicle.
- Before replacing the control unit, check the input and output and functions of the component parts.
- Do not apply excessive force when disconnecting a connector.

SERVICE INFORMATION FOR ELECTRICAL INCIDENT

< BASIC INSPECTION >

- Do not apply excessive shock to the control unit by dropping or hitting it.
- Be careful to prevent condensation in the control unit due to rapid temperature changes and do not let water or rain get on it. If water is found in the control unit, dry it fully and then install it in the vehicle.
- Be careful not to let oil to get on the control unit connector.
- Avoid cleaning the control unit with volatile oil.
- Do not disassemble the control unit, and do not remove the upper and lower covers.



- When using a DMM, be careful not to let test probes get close to each other to prevent the power transistor in the control unit from damaging battery voltage because of short circuiting.
- When checking input and output signals of the control unit, use the specified check adapter.

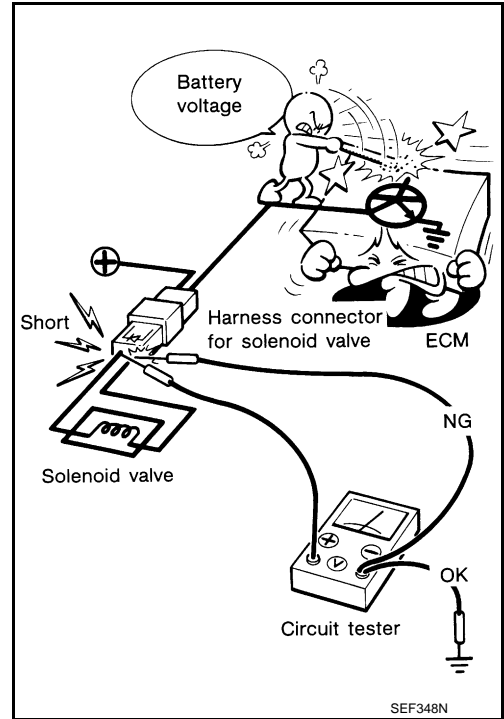

How to Check Terminal

INFOID:000000009754851

CONNECTOR AND TERMINAL PIN KIT

- Use the connector and terminal pin kits listed below when replacing connectors or terminals.
- The connector and terminal pin kits contain some of the most commonly used NISSAN/INFINITI connectors and terminals. For detailed connector and terminal pin replacement procedures, refer to the latest NISSAN/INFINITI CONNECTOR AND TERMINAL PIN SERVICE MANUAL.

GI
B
C
D
E
F
G
H
I
J
K
L
M
N
O
P

SERVICE INFORMATION FOR ELECTRICAL INCIDENT

< BASIC INSPECTION >

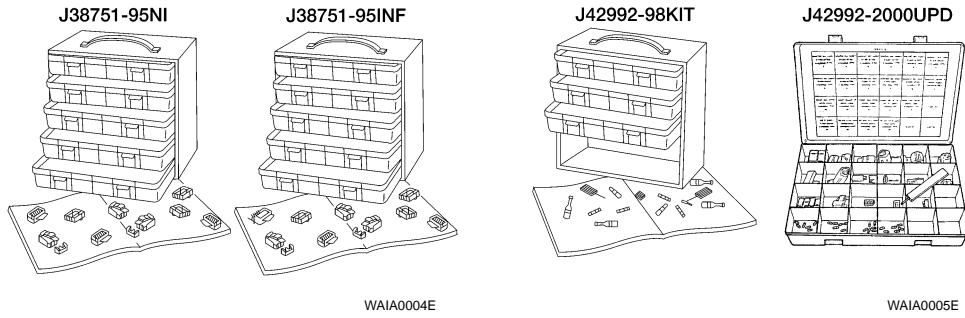
Tool number (Kent-Moore No.) Tool name	Description
- (J38751-95NI) Connector and terminal pin kit (NISSAN) - (J38751-95INF) Connector and terminal pin kit (INFINITI) - (J42992-98KIT) OBD and terminal repair kit - (J42992-2000UPD) OBD-II Connector Kit Up- date	 <p style="text-align: center;"> J38751-95NI J38751-95INF J42992-98KIT J42992-2000UPD </p> <p style="text-align: center;"> WAIA0004E WAIA0005E </p>

HOW TO PROBE CONNECTORS

- Connector damage and an intermittent connection can result from improperly probing of the connector during circuit checks.
- The probe of a digital multimeter (DMM) may not correctly fit the connector cavity. To correctly probe the connector, follow the procedures below using a "T" pin. For the best contact grasp the "T" pin using an alligator clip.

Probing from Harness Side

Standard type (not waterproof type) connector should be probed from harness side with "T" pin.

- If the connector has a rear cover such as a ECM connector, remove the rear cover before probing the terminal.
- Do not probe waterproof connector from harness side. Damage to the seal between wire and connector may result.

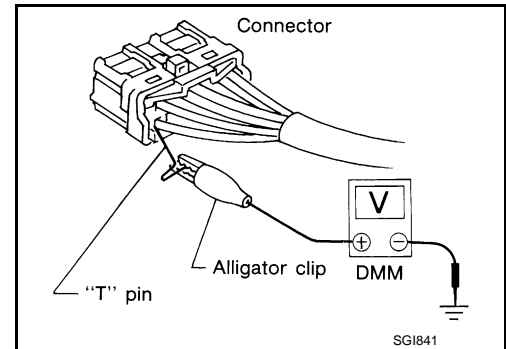

Probing from Terminal Side

FEMALE TERMINAL

- There is a small notch above each female terminal. Probe each terminal with the "T" pin through the notch. Do not insert any object other than the same type male terminal into female terminal.

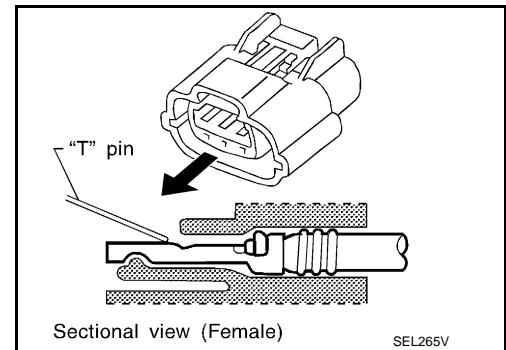

SERVICE INFORMATION FOR ELECTRICAL INCIDENT

< BASIC INSPECTION >

- Some connectors do not have a notch above each terminal. To probe each terminal, remove the connector retainer to make contact space for probing.

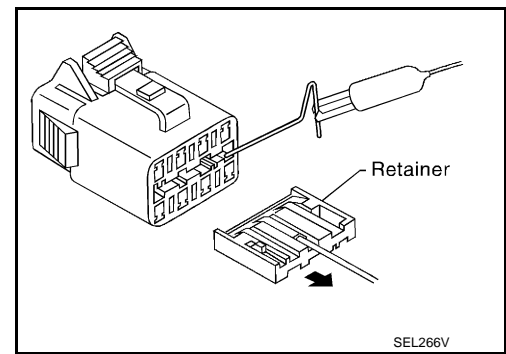

MALE TERMINAL

- Carefully probe the contact surface of each terminal using a "T" pin.

CAUTION:

Never bend terminal.

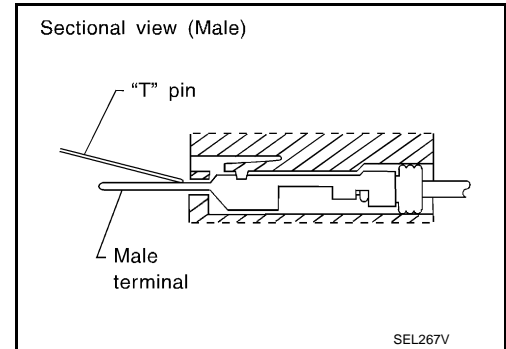

How to Check Enlarged Contact Spring of Terminal

- An enlarged contact spring of a terminal may create intermittent signals in the circuit.
- If the intermittent open circuit occurs, follow the procedure below to inspect for open wires and enlarged contact spring of female terminal.

- Assemble a male terminal and approx. 10 cm (3.9 in) of wire.

NOTE:

Use a male terminal which matches the female terminal.

- Disconnect the suspected faulty connector and hold it terminal side up.

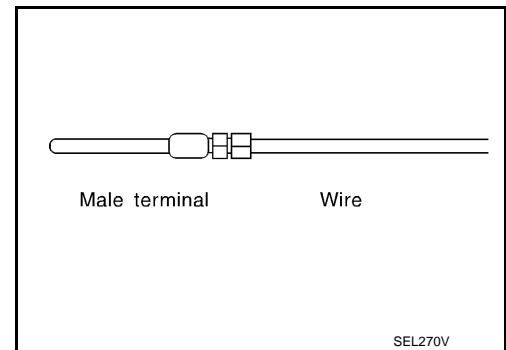

- While holding the wire of the male terminal, try to insert the male terminal into the female terminal.

CAUTION:

Never force the male terminal into the female terminal with your hands.

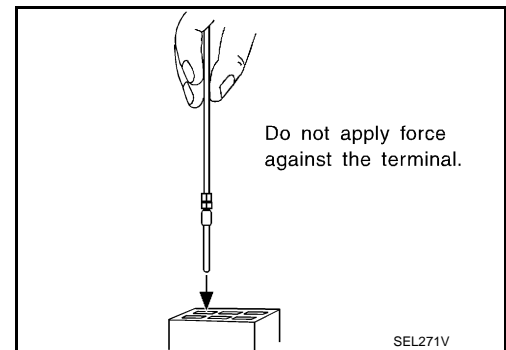

GI

B

C

D

E

F

G

H

I

J

K

L

M

N

O

P

SERVICE INFORMATION FOR ELECTRICAL INCIDENT

< BASIC INSPECTION >

4. While moving the connector, check whether the male terminal can be easily inserted or not.

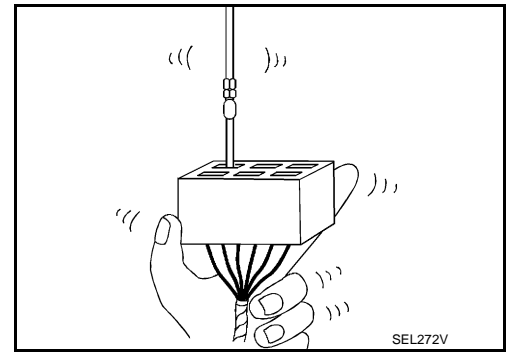

- If the male terminal can be easily inserted into the female terminal, replace the female terminal.

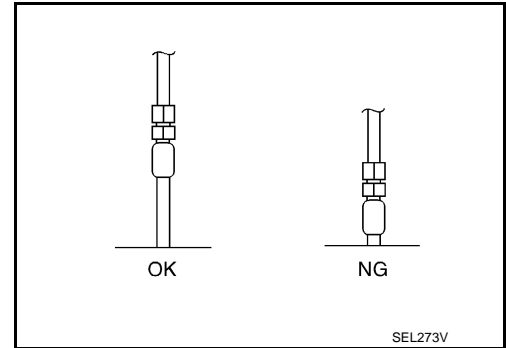

Waterproof Connector Inspection

If water enters the connector, it can short interior circuits. This may lead to intermittent problems. Check the following items to maintain the original waterproof characteristics.

RUBBER SEAL INSPECTION

- Most waterproof connectors are provided with a rubber seal between the male and female connectors. If the seal is missing, the waterproof performance may not meet specifications.
- The rubber seal may come off when connectors are disconnected. Whenever connectors are reconnected, check the rubber seal is properly installed on either side of male or female connector.

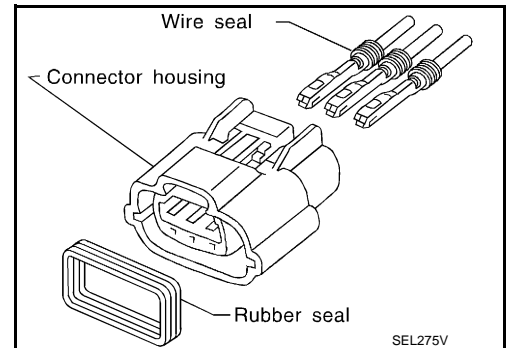

WIRE SEAL INSPECTION

- The wire seal must be installed on the wire insertion area of a waterproof connector. Be sure that the seal is installed properly.

Terminal Lock Inspection

Check for unlocked terminals by pulling wire at the end of connector. An unlocked terminal may create intermittent signals in the circuit.

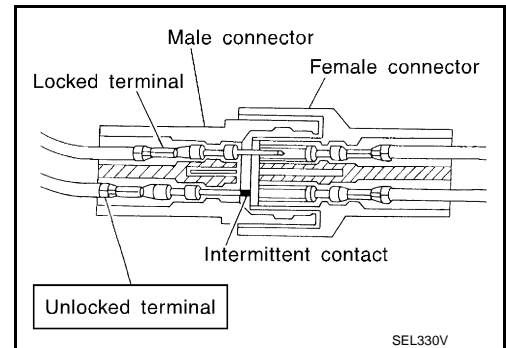

Intermittent Incident

INFOID:000000009754852

DESCRIPTION

Sometimes the symptom is not present when the vehicle is brought in for service. If possible, re-create the conditions present at the time of the incident. Doing so may help avoid a No Trouble Found Diagnosis. The fol-

SERVICE INFORMATION FOR ELECTRICAL INCIDENT

< BASIC INSPECTION >

Following section illustrates ways to simulate the conditions/environment under which the owner experiences an electrical incident.

The section is broken into the six following topics:

- Vehicle vibration
- Heat sensitive
- Freezing
- Water intrusion
- Electrical load
- Cold or hot start up

Get a thorough description of the incident from the customer. It is important for simulating the conditions of the problem.

VEHICLE VIBRATION

The problem may occur or become worse while driving on a rough road or when engine is vibrating (idle with A/C on). In such a case, you will want to check for a vibration related condition. Refer to the following illustration.

Connector & Harness

Determine which connectors and wiring harness would affect the electrical system you are inspecting. Gently shake each connector and harness while monitoring the system for the incident you are trying to duplicate. This test may indicate a loose or poor electrical connection.

Hint

Connectors can be exposed to moisture. It is possible to get a thin film of corrosion on the connector terminals. A visual inspection may not reveal this without disconnecting the connector. If the problem occurs intermittently, perhaps the problem is caused by corrosion. It is a good idea to disconnect, inspect and clean the terminals on related connectors in the system.

Sensor & Relay

Gently apply a slight vibration to sensors and relays in the system you are inspecting. This test may indicate a loose or poorly mounted sensor or relay.

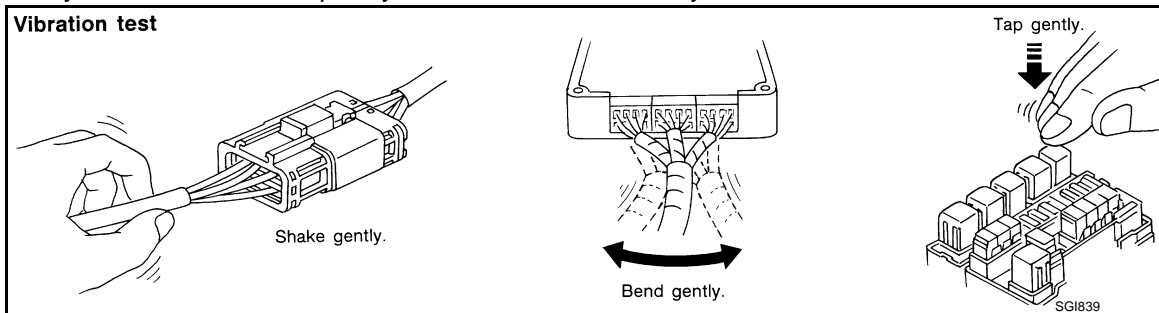

Engine Compartment

There are several reasons a vehicle or engine vibration could cause an electrical complaint. Some of the things to check for are:

- Connectors not fully seated.
- Wiring harness not long enough and is being stressed due to engine vibrations or rocking.
- Wires laying across brackets or moving components.
- Loose, dirty or corroded ground wires.
- Wires routed too close to hot components.

To inspect components under the hood, start by verifying the integrity of ground connections. (Refer to Ground Inspection described later.) First check that the system is properly grounded. Then check for loose connection by gently shaking the wiring or components as previously explained. Using the wiring diagrams inspect the wiring for continuity.

Behind the Instrument Panel

An improperly routed or improperly clamped harness can become pinched during accessory installation. Vehicle vibration can aggravate a harness which is routed along a bracket or near a screw.

Under Seating Areas

SERVICE INFORMATION FOR ELECTRICAL INCIDENT

< BASIC INSPECTION >

An unclamped or loose harness can cause wiring to be pinched by seat components (such as slide guides) during vehicle vibration. If the wiring runs under seating areas, inspect wire routing for possible damage or pinching.

HEAT SENSITIVE

- The customer's concern may occur during hot weather or after car has sat for a short time. In such cases you will want to check for a heat sensitive condition.
- To determine if an electrical component is heat sensitive, heat the component with a heat gun or equivalent.

CAUTION:

Never heat components above 60°C (140°F).

- If incident occurs while heating the unit, either replace or properly insulate the component.

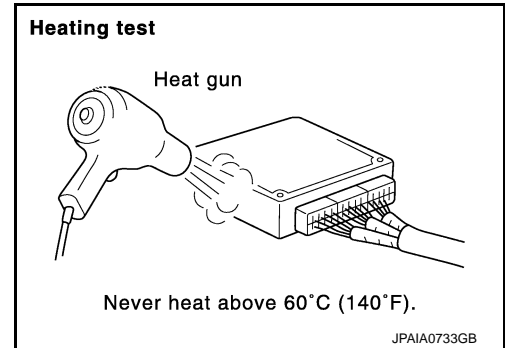

FREEZING

- The customer may indicate the incident goes away after the car warms up (winter time). The cause could be related to water freezing somewhere in the wiring/electrical system.
- There are two methods to check for this. The first is to arrange for the owner to leave his car overnight. Check it will get cold enough to demonstrate his complaint. Leave the car parked outside overnight. In the morning, do a quick and thorough diagnosis of those electrical components which could be affected.
- The second method is to put the suspect component into a freezer long enough for any water to freeze. Reinstall the part into the car and check for the reoccurrence of the incident. If it occurs, repair or replace the component.

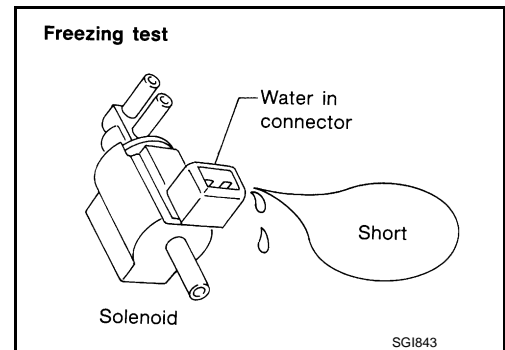

WATER INTRUSION

The incident may occur only during high humidity or in rainy/snowy weather. In such cases the incident could be caused by water intrusion on an electrical part. This can be simulated by soaking the car or running it through a car wash.

CAUTION:

Never spray water directly on any electrical components.

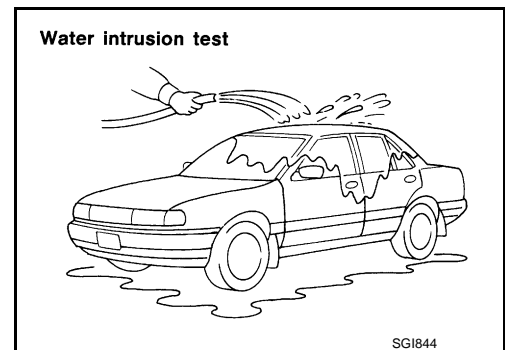

ELECTRICAL LOAD

The incident may be electrical load sensitive. Perform diagnosis with all accessories (including A/C, rear window defogger, radio, fog lamps) turned on.

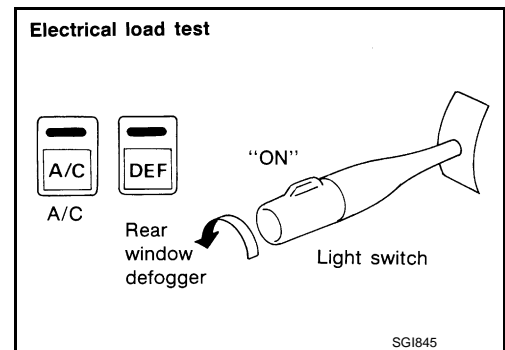

COLD OR HOT START UP

On some occasions an electrical incident may occur only when the car is started cold, or it may occur when the car is restarted hot shortly after being turned off. In these cases you may have to keep the car overnight to make a proper diagnosis.

SERVICE INFORMATION FOR ELECTRICAL INCIDENT

< BASIC INSPECTION >

Circuit Inspection

INFOID:000000009754853

GI

DESCRIPTION

- In general, testing electrical circuits is an easy task if it is approached in a logical and organized method. Before beginning it is important to have all available information on the system to be tested. Also, get a thorough understanding of system operation. Then you will be able to use the appropriate equipment and follow the correct test procedure.
- You may have to simulate vehicle vibrations while testing electrical components. Gently shake the wiring harness or electrical component to do this.

OPEN	A circuit is open when there is no continuity through a section of the circuit.	
SHORT	There are two types of shorts.	
	• SHORT CIRCUIT	When a circuit contacts another circuit and causes the normal resistance to change.
	• SHORT TO GROUND	When a circuit contacts a ground source and grounds the circuit.

NOTE:

Refer to [GI-43, "How to Check Terminal"](#) to probe or check terminal.

TESTING FOR "OPENS" IN THE CIRCUIT

Before you begin to diagnose and test the system, you should rough sketch a schematic of the system. This will help you to logically walk through the diagnosis process. Drawing the sketch will also reinforce your working knowledge of the system.

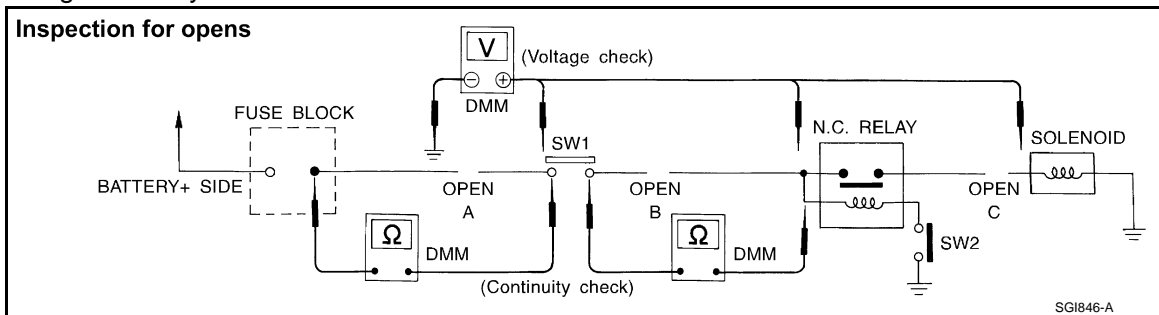

Continuity Check Method

The continuity check is used to find an open in the circuit. The digital multimeter (DMM) set on the resistance function will indicate an open circuit as over limit (no beep tone or no ohms symbol). Check to always start with the DMM at the highest resistance level.

To help in understanding the diagnosis of open circuits, please refer to the previous schematic.

- Disconnect the battery negative cable.
- Start at one end of the circuit and work your way to the other end. (At the fuse block in this example)
- Connect one probe of the DMM to the fuse block terminal on the load side.
- Connect the other probe to the fuse block (power) side of SW1. Little or no resistance will indicate that portion of the circuit has good continuity. If there were an open in the circuit, the DMM would indicate an over limit or infinite resistance condition. (point A)
- Connect the probes between SW1 and the relay. Little or no resistance will indicate that portion of the circuit has good continuity. If there were an open in the circuit, the DMM would indicate an over limit or infinite resistance condition. (point B)
- Connect the probes between the relay and the solenoid. Little or no resistance will indicate that portion of the circuit has good continuity. If there were an open in the circuit, the DMM would indicate an over limit or infinite resistance condition. (point C)

Any circuit can be diagnosed using the approach in the previous example.

Voltage Check Method

To help in understanding the diagnosis of open circuits please refer to the previous schematic.

In any powered circuit, an open can be found by methodically checking the system for the presence of voltage. This is done by switching the DMM to the voltage function.

- Connect one probe of the DMM to a known good ground.
- Begin probing at one end of the circuit and work your way to the other end.
- With SW1 open, probe at SW1 to check for voltage.
voltage: open is further down the circuit than SW1.

SERVICE INFORMATION FOR ELECTRICAL INCIDENT

< BASIC INSPECTION >

- no voltage: open is between fuse block and SW1 (point A).
 - Close SW1 and probe at relay.
 - voltage: open is further down the circuit than the relay.
 - no voltage: open is between SW1 and relay (point B).
 - Close the relay and probe at the solenoid.
 - voltage: open is further down the circuit than the solenoid.
 - no voltage: open is between relay and solenoid (point C).
- Any powered circuit can be diagnosed using the approach in the previous example.

TESTING FOR "SHORTS" IN THE CIRCUIT

To simplify the discussion of shorts in the system, please refer to the following schematic.

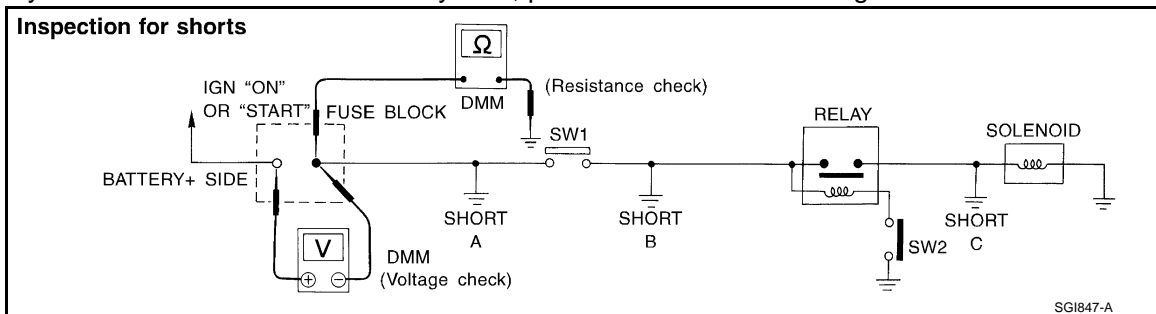

Resistance Check Method

- Disconnect the battery negative cable and remove the blown fuse.
- Disconnect all loads (SW1 open, relay disconnected and solenoid disconnected) powered through the fuse.
- Connect one probe of the DMM to the load side of the fuse terminal. Connect the other probe to a known good ground.
- With SW1 open, check for continuity.
 - continuity: short is between fuse terminal and SW1 (point A).
 - no continuity: short is further down the circuit than SW1.
- Close SW1 and disconnect the relay. Put probes at the load side of fuse terminal and a known good ground. Then, check for continuity.
 - continuity: short is between SW1 and the relay (point B).
 - no continuity: short is further down the circuit than the relay.
- Close SW1 and jump the relay contacts with jumper wire. Put probes at the load side of fuse terminal and a known good ground. Then, check for continuity.
 - continuity: short is between relay and solenoid (point C).
 - no continuity: check solenoid, retrace steps.

Voltage Check Method

- Remove the blown fuse and disconnect all loads (i.e. SW1 open, relay disconnected and solenoid disconnected) powered through the fuse.
- Turn the ignition switch to the ON or START position. Verify battery voltage at the battery + side of the fuse terminal (one lead on the battery + terminal side of the fuse block and one lead on a known good ground).
- With SW1 open and the DMM leads across both fuse terminals, check for voltage.
 - voltage: short is between fuse block and SW1 (point A).
 - no voltage: short is further down the circuit than SW1.
- With SW1 closed, relay and solenoid disconnected and the DMM leads across both fuse terminals, check for voltage.
 - voltage: short is between SW1 and the relay (point B).
 - no voltage: short is further down the circuit than the relay.
- With SW1 closed, relay contacts jumped with fused jumper wire check for voltage.
 - voltage: short is down the circuit of the relay or between the relay and the disconnected solenoid (point C).
 - no voltage: retrace steps and check power to fuse block.

GROUND INSPECTION

- Ground connections are very important to the proper operation of electrical and electronic circuits. Ground connections are often exposed to moisture, dirt and other corrosive elements. The corrosion (rust) can become an unwanted resistance. This unwanted resistance can change the way a circuit works.
- Electronically controlled circuits are very sensitive to proper grounding. A loose or corroded ground can drastically affect an electronically controlled circuit. A poor or corroded ground can easily affect the circuit. Even when the ground connection looks clean, there can be a thin film of rust on the surface.

SERVICE INFORMATION FOR ELECTRICAL INCIDENT

< BASIC INSPECTION >

- When inspecting a ground connection follow these rules:
 - Remove the ground bolt or screw.
 - Inspect all mating surfaces for tarnish, dirt, rust, etc.
 - Clean as required to assure good contact.
 - Reinstall bolt or screw securely.
 - Inspect for “add-on” accessories which may be interfering with the ground circuit.
 - If several wires are crimped into one ground eyelet terminal, check for proper crimps. Check all of the wires are clean, securely fastened and providing a good ground path. If multiple wires are cased in one eyelet check no ground wires have excess wire insulation.
- For detailed ground distribution information, refer to “Ground Distribution” in PG section.

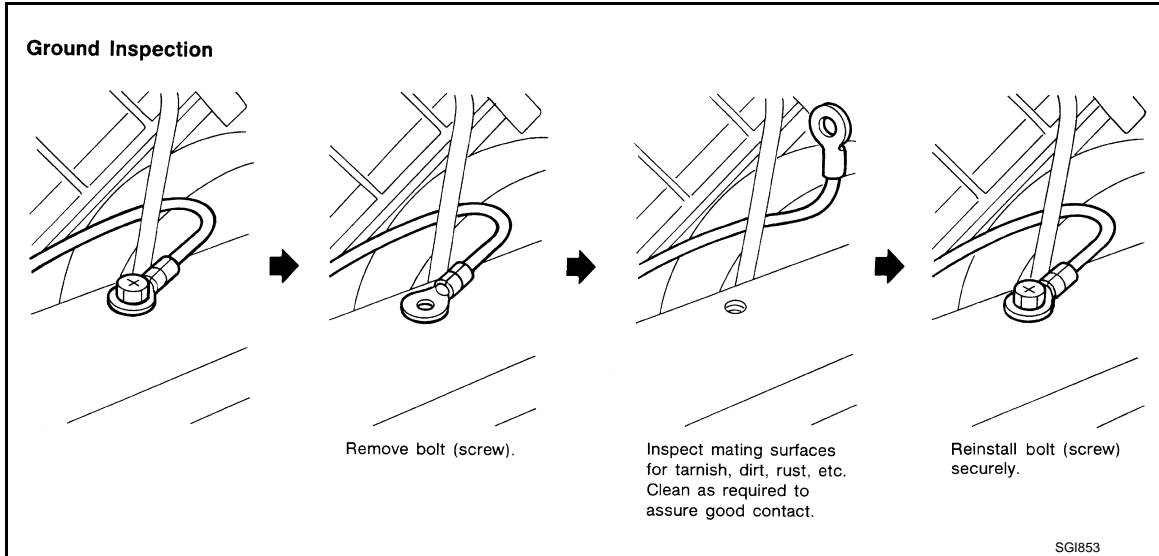

VOLTAGE DROP TESTS

- Voltage drop tests are often used to find components or circuits which have excessive resistance. A voltage drop in a circuit is caused by a resistance when the circuit is in operation.
- Check the wire in the illustration. When measuring resistance with DMM, contact by a single strand of wire will give reading of 0 ohms. This would indicate a good circuit. When the circuit operates, this single strand of wire is not able to carry the current. The single strand will have a high resistance to the current. This will be picked up as a slight voltage drop.
- Unwanted resistance can be caused by many situations as follows:
 - Undersized wiring (single strand example)
 - Corrosion on switch contacts
 - Loose wire connections or splices.
- If repairs are needed always use wire that is of the same or larger gauge.

Measuring Voltage Drop — Accumulated Method

- Connect the DMM across the connector or part of the circuit you want to check. The positive lead of the DMM should be closer to power and the negative lead closer to ground.
- Operate the circuit.
- The DMM will indicate how many volts are being used to “push” current through that part of the circuit.

SERVICE INFORMATION FOR ELECTRICAL INCIDENT

< BASIC INSPECTION >

Note in the illustration that there is an excessive 4.1 volt drop between the battery and the bulb.

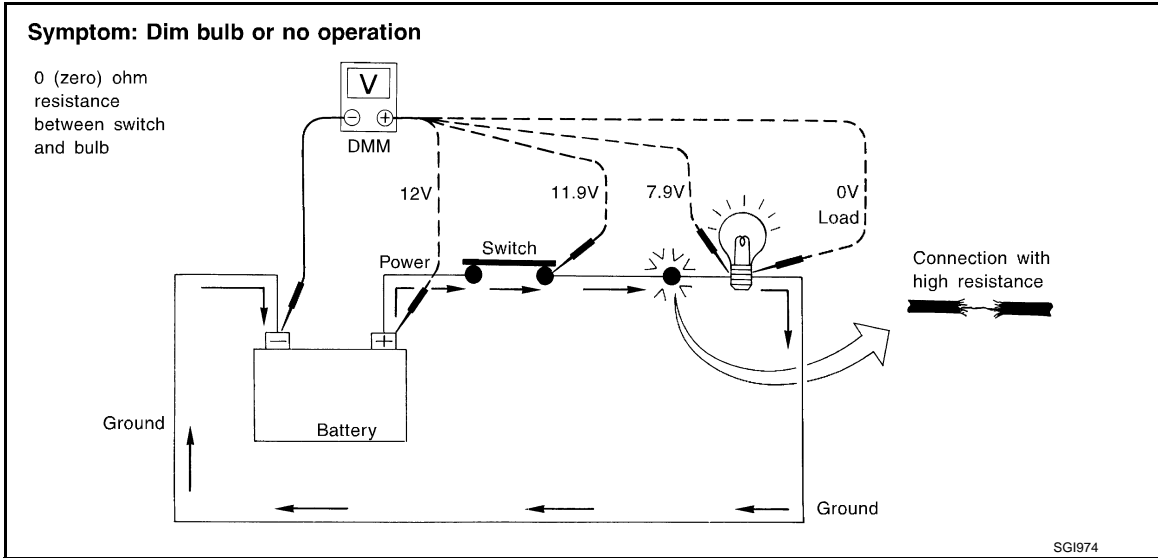

Measuring Voltage Drop — Step-by-Step

- The step-by-step method is most useful for isolating excessive drops in low voltage systems (such as those in “Computer Controlled Systems”).
- Circuits in the “Computer Controlled System” operate on very low amperage.
- The (Computer Controlled) system operations can be adversely affected by any variation in resistance in the system. Such resistance variation may be caused by poor connection, improper installation, improper wire gauge or corrosion.
- The step by step voltage drop test can identify a component or wire with too much resistance.

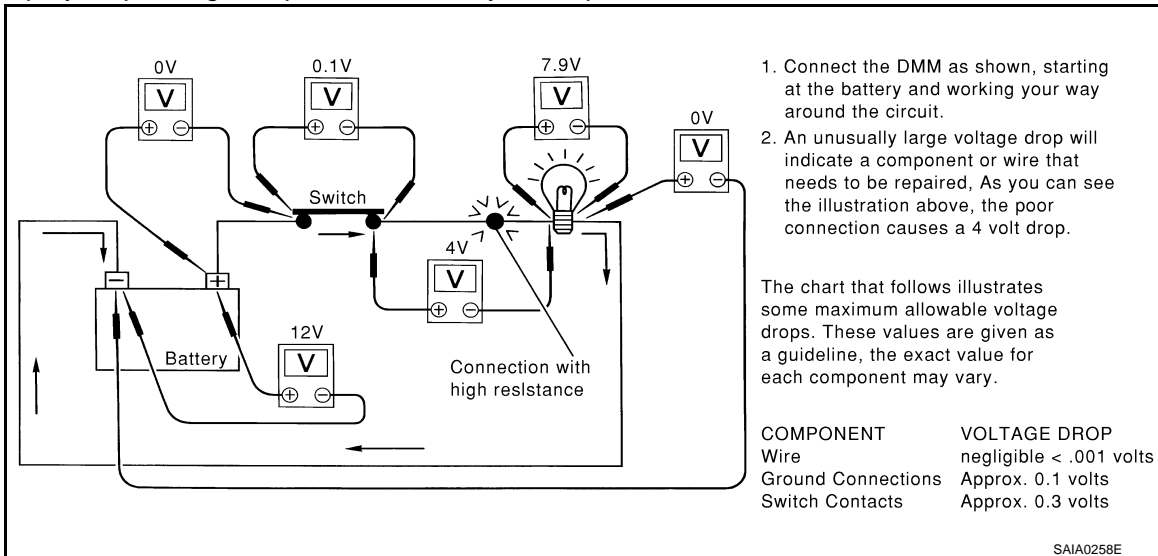

CONTROL UNIT CIRCUIT TEST

System Description

- When the switch is ON, the control unit lights up the lamp.

CASE 1

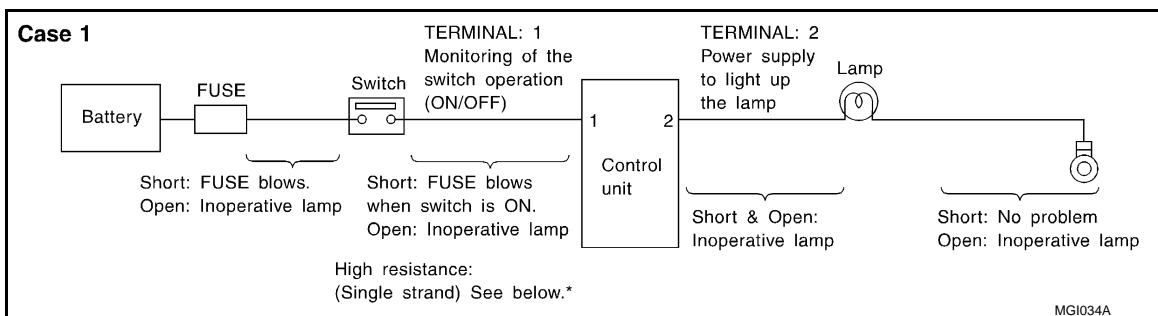

SERVICE INFORMATION FOR ELECTRICAL INCIDENT

< BASIC INSPECTION >

INPUT-OUTPUT VOLTAGE CHART

Terminal No.		Description		Condition	Value (Approx.)	In case of high resistance such as single strand (V) *
+	-	Signal name	Input/Output			
1	Body ground	Switch	Input	Switch ON	Battery voltage	Lower than battery voltage Approx. 8 (Example)
				Switch OFF	0 V	Approx. 0
2	Body ground	Lamp	Output	Switch ON	Battery voltage	Approx. 0 (Inoperative lamp)
				Switch OFF	0 V	Approx. 0

- The voltage value is based on the body ground.
- *: If high resistance exists in the switch side circuit (caused by a single strand), terminal 1 does not detect battery voltage. Control unit does not detect the switch is ON even if the switch does not turn ON. Therefore, the control unit does not supply power to light up the lamp.

CASE 2

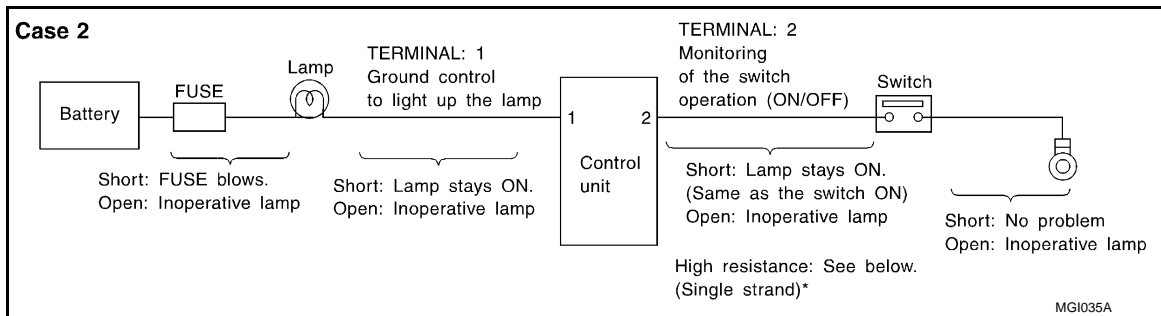

INPUT-OUTPUT VOLTAGE CHART

Terminal No.		Description		Condition	Value (Approx.)	In case of high resistance such as single strand (V) *
+	-	Signal name	Input/Output			
1	Body ground	Lamp	Output	Switch ON	0 V	Battery voltage (Inoperative lamp)
				Switch OFF	Battery voltage	Battery voltage
2	Body ground	Switch	Input	Switch ON	0 V	Higher than 0 Approx. 4 (Example)
				Switch OFF	5 V	Approx. 5

- The voltage value is based on the body ground.
- *: If high resistance exists in the switch side circuit (caused by a single strand), terminal 2 does not detect approx. 0 V. Control unit does not detect the switch is ON even if the switch does not turn ON. Therefore, the control unit does not control ground to light up the lamp.

CONSULT/GST CHECKING SYSTEM

< BASIC INSPECTION >

CONSULT/GST CHECKING SYSTEM

Description

INFOID:000000009754854

- When CONSULT/GST is connected with a data link connector (A) equipped on the vehicle side, it will communicate with the control unit equipped in the vehicle and then enable various kinds of diagnostic tests.

1 : Instrument lower cover LH

- Refer to "CONSULT Software Operation Manual" for more information.

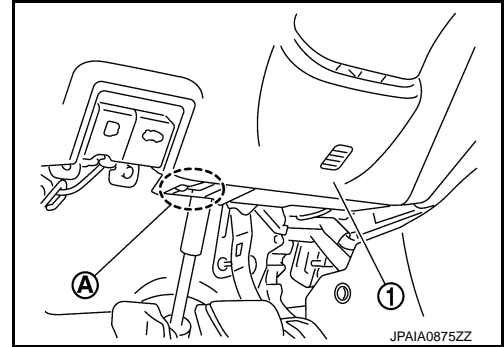

CONSULT Function and System Application*1

INFOID:000000009754855

FUNCTION

Mode	Function
All DTC Reading	Display all DTCs or diagnostic items that all ECUs are recording and judging.
Work Support	This mode enables a technician to adjust some devices faster and more accurately.
Self Diagnostic Results	Retrieve DTC from ECU and display diagnostic items.
Data Monitor	Monitor the input/output signal of the control unit in real time.
CAN Diagnosis	This mode displays a network diagnosis result about CAN by diagram.
CAN Diagnosis Support Monitor	It monitors the status of CAN communication.
Active Test	Send the drive signal from CONSULT to the actuator. The operation check can be performed.
ECU Identification	Display the ECU identification number (part number etc.) of the selected system.
Configuration	Function to READ/WRITE vehicle configuration.
SRT&P-DTC Confirmation	The state of System Readiness Test (SRT) items, the presence or absence of permanent DTC*, and driving conditions can be checked.
DTC work support	DTC reproduction procedure can be performed speedily and precisely.
Others	Other results or histories, etc. that are recorded in ECU are displayed.

*: Permanent DTC is not applied for regions where it is not mandated.

SYSTEM APPLICATION*1

System	All DTC Reading	Work Support	Self Diagnostic Results	Data Monitor	CAN Diagnosis	CAN Diagnosis Support Monitor	Active Test	ECU Identification	Configuration	SRT&P-DTC Confirmation	DTC work support	Others
ENGINE	x	x	x	x	x	x	x	x	-	x*2	x	-
TRANSMISSION	x	x	x	x	x	x	-	x	-	-	-	• CALIB DATA
AIR BAG	x	-	x	-	x	-	-	x	-	-	-	• TROUBLE DIAG RECORD • SELF-DIAG RESULT [CAN] • Cause of Warning Lamp

CONSULT/GST CHECKING SYSTEM

< BASIC INSPECTION >

System	All DTC Reading	Work Support	Self Diagnostic Results	Data Monitor	CAN Diagnosis	CAN Diagnosis Support Monitor	Active Test	ECU Identification	Configuration	SRT&P-DTC Confirmation	DTC work support	Others
METER / M&A	x	x	x	x	x	x	-	-	-	-	-	• Warning History
BCM	x	x	x	x	x	x	x	x	x	-	-	-
IPDM E/R	x	-	x	x	x	x	x	x	-	-	-	-
EPS	x	-	x	x	x	x	-	x	-	-	-	-
ALL MODE AWD / 4WD	x	x	x	x	x	x	x	x	-	-	-	-
MULTI DISPLAY	x	-	x	x	x	x	x	-	-	-	-	-
HVAC	-	x	x	x	x	x	x	x	-	-	-	-
ABS	x	x	x	x	x	x	x	x	-	-	-	-
OCCUPANT DETECTION	-	x	-	-	-	-	-	-	-	-	-	-

x: Applicable

*1: If GST application is equipped, functions in accordance with SAE J1979 and ISO 15031-5 can be used.

*2: Permanent DTC is not applied for regions where it is not mandated.

CONSULT/GST Data Link Connector (DLC) Circuit

INFOID:000000009754856

INSPECTION PROCEDURE

If the CONSULT/GST cannot diagnose the system properly, check the following items.

Symptom	Check item
CONSULT/GST cannot access any system.	<ul style="list-style-type: none"> CONSULT/GST DLC power supply circuit (Terminal 8 and 16) and ground circuit (Terminal 4 and 5)
CONSULT cannot access individual system. (Other systems can be accessed.)	<ul style="list-style-type: none"> Power supply and ground circuit for the control unit of the system (For detailed circuit, refer to wiring diagram for each system.) Open or short circuit between the system and CONSULT DLC (For detailed circuit, refer to wiring diagram for each system.) Open or short circuit CAN communication line. Refer to LAN-15, "Trouble Diagnosis Flow Chart".

NOTE:

The DDL1 and DDL2 circuits from DLC pins 12, 13, 14 and 15 may be connected to more than one system. A short in a DDL circuit connected to a control unit in one system may affect CONSULT access to other systems. If the GST cannot operate properly, check the circuit based on the information of SAE J1962 and ISO 15031-3.

CONSULT/GST CHECKING SYSTEM

< BASIC INSPECTION >

GI

B

C

D

E

F

G

H

I

J

K

L

M

N

O

P

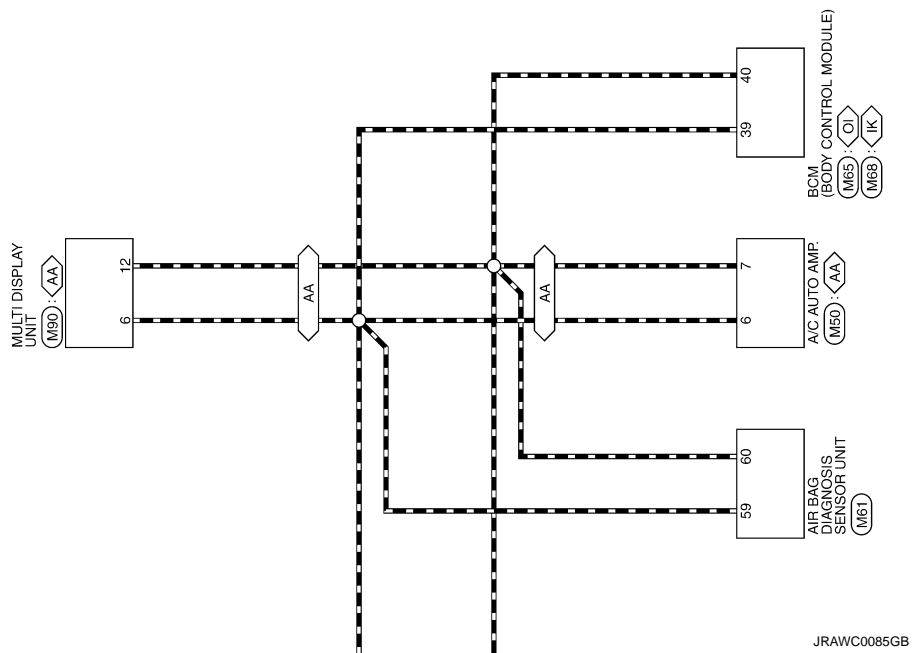

CONSULT/GST CHECKING SYSTEM

< BASIC INSPECTION >

CONSULT CHECKING SYSTEM

Connector No.	B24
Connector Name	OCCUPANT DETECTION SYSTEM CONTROL UNIT
Connector Type	TH08PW-NH



Terminal No.	Color Of Wire	Signal Name [Specification]
2	R	COMMUNICATION
4	BR	IGN
5	B	GND
7	GR	K-LINE

Connector No.	B47
Connector Name	AWD CONTROL MODULE
Connector Type	TH20PW-TB6



Terminal No.	Color Of Wire	Signal Name [Specification]
1	GR	BATTERY
3	LG	IGN SW
4	L	CAN-H
5	P	AWD-V SW
9	W	GND
10	B	GND
11	B	SOL BAT
12	Y	AWD SW
13	G	2WD SW
21	Y	AWD SW
23	R	AWD SOL L-
24	V	AWD SOL L+
25	W	AWD SOL R-
26	Y	AWD SOL R+

Connector No.	E13
Connector Name	INTELLIGENT POWER DISTRIBUTION MODULE ENGINE ROOM
Connector Type	TH12FW-NH



Terminal No.	Color Of Wire	Signal Name [Specification]
23	SB	-
25	BR	-
26	P	-
27	L	-
28	Y	-
30	V	-
31	Y	-
33	G	-
34	L	-

Connector No.	E18
Connector Name	ECM
Connector Type	RH24FGY-R28-R-RH

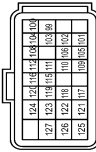

Terminal No.	Color Of Wire	Signal Name [Specification]
99	P	CAN COMMUNICATION LINE (CAN-L)
100	L	CAN COMMUNICATION LINE (CAN-H)
101	V	SENSOR POWER SUPPLY
102	R	ACCELERATOR PEDAL POSITION SENSOR 1
103	BR	PNP SIGNAL
104	R	DATA LINK CONNECTOR
105	GR	SENSOR GROUND (ACCELERATOR PEDAL POSITION SENSOR 1)
106	Y	POWER SUPPLY FOR ECM (BACKUP)
108	GR	CLUTCH PEDAL POSITION SWITCH
109	O	IGNITION SWITCH

110	P	ASC3 STEERING SWITCH
111	B	SENSOR GROUND
112	SB	ECM REC'D USER SWITCH (OFF)
113	SB	ECM REC'D USER SWITCH
114	SG	BRAKE PEDAL POSITION SWITCH
115	SG	FUEL PUMP RELAY
116	Y	SENSOR POWER SUPPLY
117	O	ACCELERATOR PEDAL POSITION SENSOR 2
118	BR	SENSOR GROUND
119	Y	POWER SUPPLY FOR ECM
120	G	THROTTLE CONTROL MOTOR POWER SUPPLY
121	GR	ECM GROUND
122	B/Y	ECM GROUND
123	B/Y	A/F SENSOR 1 HEATER
124	B/Y	HEATED OXYGEN SENSOR 2 HEATER
125	L	ECM GROUND
126	W	ECM GROUND
127	B/Y	ECM GROUND

Connector No.	E35
Connector Name	ABS ACTUATOR AND ELECTRIC UNIT CONTROL UNIT
Connector Type	RH28FB-NUH-UH

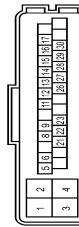

Terminal No.	Color Of Wire	Signal Name [Specification]
1	W	BAT (MTP)
2	L	BAT (SOL)
3	B	GND (SOL)
4	B	GND (MTR)
5	GR	VDC OFF SW
6	GR	STOP LAMP SW
8	SB	STOP LAMP SW
9	P	CAN-L
11	BR	DP RR
12	W	DS FR
13	G	VCC
14	R	SERIAL+
15	Y	DS RR
16	V	IGN
17	W	REVERSE SIGNAL
21	Y	DP FR
22	L	CAN-H

23	LG	DP FL
28	SB	DP RL
32	BR	DS FL
33	BR	DS RL
38	B	SERIAL-
39	W	SERIAL+
40	O	DS RL

Connector No.	F81
Connector Name	TCM (TRANSMISSION CONTROL MODULE)
Connector Type	RH40FB-R28-L-RH

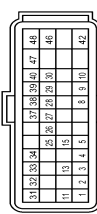

Terminal No.	Color Of Wire	Signal Name [Specification]
1	G	R RANGE SW
2	Y	N RANGE SW
3	W	D RANGE SW
4	V	-
5	B	GROUND
8	BR	CLOCK (SEL 2)
9	G	CHIP SELECT (SEL 1)
10	W	BATE I/O (SEL 3)
11	W	DATA LINK CONNECTOR
13	SB	CVT FLUID TEMPERATURE SENSOR
15	B	SECONDARY PRESSURE SENSOR
25	Y	SENSOR GROUND
26	LG	SENSOR POWER SUPPLY
27	GR	STEP MOTOR D
28	V	STEP MOTOR C
29	BG	STEP MOTOR B
30	P	STEP MOTOR A
31	R	CAN-L
32	L	CAN-H
33	BG	PRIMARY SPEED SENSOR
34	R	SECONDARY SPEED SENSOR
37	L	LOCK-UP SELECT SOLENOID VALVE
38	G	TORQUE CONVERTER CLUTCH SOLENOID VALVE
39	W	SECONDARY PRESSURE SOLENOID VALVE
40	Y	LINE PRESSURE SOLENOID VALVE
42	B	GROUND
46	LG	IGNITION POWER SUPPLY

CONSULT/GST CHECKING SYSTEM

< BASIC INSPECTION >

GI

CONSULT CHECKING SYSTEM

47	BG	BATTERY POWER SUPPLY (MEMORY BACK-UP)
48	Y	IGNITION POWER SUPPLY

Connector No.	M4
Connector Name	DATA LINK CONNECTOR
Connector Type	BD18FW

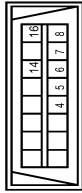

Terminal No.	Color	Wire	Signal Name [Specification]
4	B	-	-
5	B	-	-
6	L	-	-
7	W	-	-
8	LG	-	-
14	P	-	-
16	Y	-	-

Connector No.	M34
Connector Name	COMBINATION METER
Connector Type	TH40FY-NH



Terminal No.	Color	Wire	Signal Name [Specification]
1	L	-	CAN-H
2	P	-	CAN-L
4	V	-	VEHICLE SPEED SIGNAL (P-PULSE) [With front fog lamp]
4	Y	-	VEHICLE SPEED SIGNAL (P-PULSE) [Without front fog lamp]
5	G	-	PADDLE SHIFTER UP SWITCH SIGNAL
6	BR	-	FUEL LEVEL SENSOR SIGNAL
7	R	-	AIR BAG SIGNAL
8	P	-	- [Without front fog lamp]
8	Y	-	- [With front fog lamp]

9	O	DATA LINK (ELECTRONIC CONTROL SIGNAL) (Without front fog lamp)
9	W	DATA LINK (ELECTRONIC CONTROL SIGNAL) (With front fog lamp)
10	SB	DATA LINK (ELECTRONIC CONTROL SIGNAL) (Without front fog lamp)
10	SB	DATA LINK (ELECTRONIC CONTROL SIGNAL) (With front fog lamp)
11	G	PARKING BRAKE SWITCH SIGNAL
12	B	BRAKE FLUID LEVEL SWITCH SIGNAL
13	R	REAR WINDOW WIPER MOTOR SIGNAL [With front fog lamp]
13	R	REAR WINDOW WIPER MOTOR SIGNAL [Without front fog lamp]
14	GR	REAR WINDOW WIPER MOTOR SIGNAL [With front fog lamp]
14	GR	REAR WINDOW WIPER MOTOR SIGNAL [Without front fog lamp]
14	V	MANUAL MODE SHIFTER SIGNAL [With front fog lamp]
14	V	MANUAL MODE SHIFTER SIGNAL [Without front fog lamp]
15	L	ACC POWER SUPPLY
16	O	MANUAL MODE SHIFTER DOWN SIGNAL [With front fog lamp]
16	O	MANUAL MODE SHIFTER DOWN SIGNAL [Without front fog lamp]
17	G	WASHER LEVEL SWITCH SIGNAL [Without front fog lamp]
17	W	WASHER LEVEL SWITCH SIGNAL [With front fog lamp]
18	R	SECURITY SIGNAL
19	GR	AMBIENT SENSOR SIGNAL
20	LG	AMBIENT SENSOR GROUND [With front fog lamp]
20	R	AMBIENT SENSOR GROUND [Without front fog lamp]
21	B	GROUND
22	B	GROUND
23	B	GROUND
24	L	FUEL LEVEL SENSOR GROUND
25	B	VDC GROUND
26	V	PADDLE SHIFTER DOWN SWITCH SIGNAL
27	LG	BATTERY POWER SUPPLY
28	GR	IGNITION SIGNAL
29	LG	PASSENGER SEAT BELT TENSIONER SIGNAL [With front fog lamp]
29	V	PASSENGER SEAT BELT TENSIONER SIGNAL [Without front fog lamp]
31	P	A/C AUTO AMP CONNECTION RECOGNITION SIGNAL
36	LG	MANUAL MODE SIGNAL [With front fog lamp]
36	Y	MANUAL MODE SIGNAL [Without front fog lamp]
37	G	NON-RESISTOR MODE SIGNAL [Without front fog lamp]
37	G	NON-RESISTOR MODE SIGNAL [With front fog lamp]
38	P	ALTERNATOR SIGNAL

Connector No.	M37
Connector Name	EPS CONTROL UNIT
Connector Type	TH40FW-NH



Terminal No.	Color	Wire	Signal Name [Specification]
1	P	-	CAN-L
2	L	-	CAN-H
4	LG	-	IGN

Connector No.	M5D
Connector Name	A/C AUTO AMP
Connector Type	TH40FW-NH

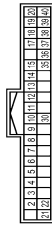

Terminal No.	Color	Wire	Signal Name [Specification]
2	LG	-	IN-VEHICLE SENSOR SIGNAL
3	V	-	INTAKE SENSOR SIGNAL
4	GR	-	AMBIENT SENSOR SIGNAL
5	P	-	SUNLOAD SENSOR SIGNAL
6	L	-	CAN-L
7	P	-	INTAKE DOOR MOTOR PER POWER SUPPLY
8	W	-	A/C AUTO AMP CONNECTION RECOGNITION SIGNAL
9	P	-	SENSOR GROUND
10	R	-	IGNITION POWER SUPPLY
11	SB	-	BATTERY POWER SUPPLY
12	GR	-	POWER BLUENER CAN SIGNAL
14	LG	-	A/C ON SIGNAL
15	V	-	A/MIX DRIVE SIGNAL 4
17	BR	-	A/MIX DRIVE SIGNAL 2
18	GR	-	A/MIX DRIVE SIGNAL 3
19	W	-	A/MIX DRIVE SIGNAL 1
20	L	-	IGNITION POWER SUPPLY
21	G	-	GROUND
22	SB	-	REC DRIVE SIGNAL
30	B	-	FRE DRIVE SIGNAL
35	G	-	MODE DRIVE SIGNAL 4
37	R	-	MODE DRIVE SIGNAL 3
38	P	-	MODE DRIVE SIGNAL 2
39	Y	-	MODE DRIVE SIGNAL 1
40	V	-	MODE DRIVE SIGNAL 1

Connector No.	M61
Connector Name	AIR BAG DIAGNOSIS SENSOR UNIT
Connector Type	NW28FY-EX

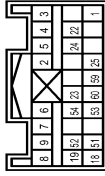

Terminal No.	Color	Wire	Signal Name [Specification]
1	BR	-	IGN
2	B	-	GND
3	Y	-	DR 1 (+)
4	Y/G	-	DR1 (-) DR2 (-)
5	Y	-	DR 2 (+)
6	Y/R	-	ASI (+)
7	Y/B	-	ASI (-)
8	Y	-	ASZ (+)
9	Y	-	ASZ (-)
18	LG	-	EGZS (+)
19	V	-	EGZS (-)
22	SHIELD	-	SHIELD
23	R	-	AIR BAG W/L
24	V	-	SEAT BELT W/L
25	G	-	CUTOFF TELLTALE
31	R	-	FMSS SENS RH+
32	G	-	FMSS SENS RH-
33	R	-	FMSS SENS LH+
34	G	-	FMSS SENS LH-
59	BR	-	CAN-L
60	P	-	CAN-L

B
C
D
E
F
G
H
I
J
K
L
M
N
O
P

CONSULT/GST CHECKING SYSTEM

< BASIC INSPECTION >

CONSULT CHECKING SYSTEM

Connector No.	M85
Connector Name	BCM (BODY CONTROL MODULE)
Connector Type	TH40FB-NH

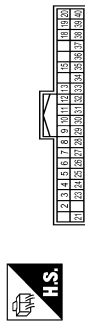

Terminal No.	Color Of Wire	Signal Name [Specification]
2	L	COMBI SW INPUT 5
3	GR	COMBI SW INPUT 4
4	BR	COMBI SW INPUT 3
5	G	COMBI SW INPUT 2
6	W	COMBI SW INPUT 1
7	L	KEY CYL UNLOCK SW
8	R	KEY CYL LOCK SW
9	R	STOP LAMP SW
10	W	REAR WINDOW DEF SW
11	L	IGN SW ACC
12	Y	DOOR LK & UNLK SW LOCK
13	BR	DOOR LK & UNLK SW UNLOCK
14	W	—
15	W	RECEIVER GND
18	V	RECEIVER PWR SPLY
19	BR	RECEIVER COMM
20	G	RECEIVER GND
21	R	RECEIVER ANT
22	R	SECURITY LAMP CONT
24	SB	DOUBLE LNK
25	LG	MATS ANT AMP
26	B	THEIRMO CONT AMP
27	W	A/C SW
28	O	BLOWER FAN SW
29	L	HAZARD SW
30	L	BK DOOR OPENER SW
31	G	FR DEFROST SW
32	LG	COMBI SW OUTPUT 5
33	Y	COMBI SW OUTPUT 4
34	R	COMBI SW OUTPUT 3
35	R	COMBI SW OUTPUT 2
36	P	COMBI SW OUTPUT 1
37	GR	KEY SW
38	R	IGN SW ON
39	L	CAN-H
40	P	CAN-L

Connector No.	M88
Connector Name	BCM (BODY CONTROL MODULE)
Connector Type	TH40FB-NH

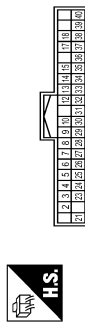

Terminal No.	Color Of Wire	Signal Name [Specification]
2	L	COMBI SW INPUT 5
3	GR	COMBI SW INPUT 4
4	BR	COMBI SW INPUT 3
5	G	COMBI SW INPUT 2
6	W	COMBI SW INPUT 1
7	L	KEY CYL UNLOCK SW
8	R	KEY CYL LOCK SW
9	R	STOP LAMP SW 1
10	W	—
12	GR	DOOR LK & UNLK SW LOCK (Without front fog lamp)
13	BR	DOOR LK & UNLK SW UNLOCK
14	P	OPTICAL SENS
15	W	RR DEFROGER SW
16	R	OPTICAL SENS PWR SPLY
17	R	RECEIVER GND
18	V	RECEIVER PWR SPLY
19	BR	RECEIVER COMM
20	G	RECEIVER GND
21	R	RECEIVER ANT
22	R	SECURITY LAMP CONT
24	SB	DOUBLE LNK
25	LG	MATS ANT AMP
26	B	THEIRMO AMP
27	W	A/C SW (With front fog lamp)
28	Y	A/C SW (Without front fog lamp)
28	LG	BLOWER FAN SW (Without front fog lamp)
29	L	BLOWER FAN SW (With front fog lamp)
29	L	HAZARD SW (With front fog lamp)
29	SB	HAZARD SW (Without front fog lamp)
30	L	BK DOOR OPENER SW
31	GR	DR DOOR UNLK SENS
32	LG	COMBI SW OUTPUT 5
33	Y	COMBI SW OUTPUT 4
34	V	COMBI SW OUTPUT 3
35	R	COMBI SW OUTPUT 2
36	P	COMBI SW OUTPUT 1
37	G	DETENT SW
38	SB	RECEIVER COMM

39	L	CAN-H
40	P	CAN-L

Connector No.	M80
Connector Name	MULTI DISPLAY UNIT
Connector Type	TH12PW-NH

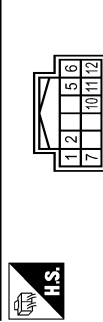

Terminal No.	Color Of Wire	Signal Name [Specification]
1	Y	BAT
2	V	ILL+
5	GR	ILL CONT
6	L	CAN-H
7	SB	IGN
10	B	GND
11	B	GND
12	P	CAN-L

JRAWC0881GB

INSPECTION AND ADJUSTMENT

< BASIC INSPECTION >

INSPECTION AND ADJUSTMENT

ADDITIONAL SERVICE WHEN REMOVING BATTERY NEGATIVE TERMINAL

ADDITIONAL SERVICE WHEN REMOVING BATTERY NEGATIVE TERMINAL : Re- quired Procedure After Battery Disconnection

INFOID:000000009754858

SYSTEM	ITEM	REFERENCE
Automatic air conditioning system	Temperature setting trimmer	HAC-47. "Temperature Setting Trimmer"
	Foot position setting trimmer	HAC-48. "Foot Position Setting Trimmer"
	Inlet port memory function*	—
	Inlet port memory function (FRE)	HAC-48. "Inlet Port Memory Function (FRE)"
	Inlet port memory function (REC)	HAC-47. "Inlet Port Memory Function (REC)"
	Gas sensor sensitivity adjustment function*	—
	Auto intake switch interlocking movement change*	—
	Clean switch interlocking movement change*	—
Automatic drive positioner*	Automatic drive positioner system	—
Power window control	Power window control system	PWC-25. "Description"
Sunroof system	Sunroof system	—
Sunshade system	Sunshade system	—
Rear view monitor	Rear view monitor predictive course line center position adjustment	—
Around view monitor*	Predictive course line center position adjustment	—
Automatic back door system*	Automatic back door system	—
Engine oil level read*	Engine oil level read	—

*: Not equipped.

GI

B

C

D

E

F

G

H

I

J

K

L

M

N

O

P