

# SECTION HAC

## HEATER & AIR CONDITIONING CONTROL SYSTEM

### CONTENTS

<b>AUTOMATIC AIR CONDITIONING</b>		
<b>PRECAUTION</b> .....	5	
<b>PRECAUTIONS</b> .....	5	
Precaution for Supplemental Restraint System (SRS) "AIR BAG" and "SEAT BELT PRE-TENSIONER" .....	5	
Precautions for Removing of Battery Terminal .....	5	
<b>SYSTEM DESCRIPTION</b> .....	6	
<b>COMPONENT PARTS</b> .....	6	
Component Parts Location .....	6	
Component Description .....	7	
<b>A/C UNIT ASSEMBLY</b> .....	7	
A/C UNIT ASSEMBLY : Aspirator .....	7	
A/C UNIT ASSEMBLY : Intake Sensor .....	7	
A/C UNIT ASSEMBLY : Air Mix Door Motor .....	7	
A/C UNIT ASSEMBLY : Mode Door Motor .....	8	
A/C UNIT ASSEMBLY : Intake Door Motor .....	8	
A/C UNIT ASSEMBLY : Blower Motor .....	8	
A/C UNIT ASSEMBLY : Power Transistor .....	8	
Multi Display Unit .....	9	
A/C Auto Amp. ....	9	
BCM .....	9	
ECM .....	9	
IPDM E/R .....	9	
Ambient Sensor .....	9	
In-vehicle Sensor .....	9	
Sunload Sensor .....	9	
Refrigerant Pressure Sensor .....	9	
Magnet Clutch .....	10	
<b>SYSTEM</b> .....	11	
System Diagram .....	11	
System Description .....	11	
Temperature Control .....	12	
Air Outlet Control .....	13	
Air Flow Control .....	13	
Air Inlet Control .....	14	
Compressor Control .....	14	
Door Control .....	15	
ECO Mode Control .....	18	
Fail-safe .....	18	
<b>OPERATION</b> .....	20	
Switch Name and Function .....	20	
<b>DIAGNOSIS SYSTEM (A/C AUTO AMP.)</b> .....	23	
Description .....	23	
CONSULT Function .....	23	
<b>DIAGNOSIS SYSTEM (BCM)</b> .....	26	
<b>COMMON ITEM</b> .....	26	
COMMON ITEM : CONSULT Function (BCM - COMMON ITEM) .....	26	
<b>AIR CONDITIONER</b> .....	27	
AIR CONDITIONER : CONSULT Function (BCM - AIR CONDITIONER) (Automatic A/C) .....	27	
<b>ECU DIAGNOSIS INFORMATION</b> .....	29	
<b>A/C AUTO AMP.</b> .....	29	
Reference Value .....	29	
Fail-safe .....	32	
DTC Index .....	32	
<b>MULTI DISPLAY UNIT, BCM, ECM, IPDM E/R</b> .....	33	
List of ECU Reference .....	33	
<b>WIRING DIAGRAM</b> .....	34	
<b>AUTOMATIC AIR CONDITIONING SYSTEM</b> .....	34	
Wiring Diagram .....	34	
<b>BASIC INSPECTION</b> .....	42	
<b>DIAGNOSIS AND REPAIR WORK FLOW</b> .....	42	
Work Flow .....	42	

A  
B  
C  
D  
E  
F  
G  
H  
HAC  
J  
K  
L  
M  
N  
O  
P

<b>OPERATION INSPECTION</b> .....	45	Diagnosis Procedure .....	70
Work Procedure .....	45	Component Inspection .....	71
<b>SYSTEM SETTING</b> .....	47	<b>POWER SUPPLY AND GROUND CIRCUIT</b> ....	72
Temperature Setting Trimmer .....	47	<b>A/C AUTO AMP.</b> .....	72
Inlet Port Memory Function (REC) .....	47	A/C AUTO AMP. : Diagnosis Procedure .....	72
Inlet Port Memory Function (FRE) .....	48	<b>A/C ON SIGNAL</b> .....	74
Foot Position Setting Trimmer .....	48	Component Function Check .....	74
<b>DOOR MOTOR STARTING POSITION RE-SET</b> .....	49	Diagnosis Procedure .....	74
Description .....	49	<b>BLOWER FAN ON SIGNAL</b> .....	76
Work Procedure .....	49	Component Function Check .....	76
<b>DTC/CIRCUIT DIAGNOSIS</b> .....	50	Diagnosis Procedure .....	76
<b>U1000 CAN COMM CIRCUIT</b> .....	50	<b>BLOWER MOTOR</b> .....	78
Description .....	50	Diagnosis Procedure .....	78
DTC Logic .....	50	Component Inspection (Blower Motor) .....	80
Diagnosis Procedure .....	50	Component Inspection (Blower Relay) .....	81
<b>U1010 CONTROL UNIT (CAN)</b> .....	51	<b>MAGNET CLUTCH</b> .....	82
Description .....	51	Component Function Check .....	82
DTC Logic .....	51	Diagnosis Procedure .....	82
Diagnosis Procedure .....	51	<b>SYMPTOM DIAGNOSIS</b> .....	83
<b>B2578, B2579 IN-VEHICLE SENSOR</b> .....	52	<b>AUTOMATIC AIR CONDITIONER SYSTEM</b> ...	83
DTC Logic .....	52	Symptom Table .....	83
Diagnosis Procedure .....	52	<b>INSUFFICIENT COOLING</b> .....	85
Component Inspection .....	53	Description .....	85
<b>B257B, B257C AMBIENT SENSOR</b> .....	55	Diagnosis Procedure .....	85
DTC Logic .....	55	<b>INSUFFICIENT HEATING</b> .....	87
Diagnosis Procedure .....	55	Description .....	87
Component Inspection .....	56	Diagnosis Procedure .....	87
<b>B2581, B2582 INTAKE SENSOR</b> .....	58	<b>COMPRESSOR DOES NOT OPERATE</b> .....	88
DTC Logic .....	58	Description .....	88
Diagnosis Procedure .....	58	Diagnosis Procedure .....	88
Component Inspection .....	59	<b>REMOVAL AND INSTALLATION</b> .....	89
<b>B2630, B2631 SUNLOAD SENSOR</b> .....	61	<b>CONTROLLER</b> .....	89
DTC Logic .....	61	Removal and Installation .....	89
Diagnosis Procedure .....	61	<b>A/C AUTO AMP.</b> .....	90
Component Inspection .....	62	Removal and Installation .....	90
<b>B27A0, B27A1 INTAKE DOOR MOTOR</b> .....	64	<b>AMBIENT SENSOR</b> .....	91
DTC Logic .....	64	Removal and Installation .....	91
Diagnosis Procedure .....	64	<b>IN-VEHICLE SENSOR</b> .....	92
Component Inspection (PBR) .....	66	Removal and Installation .....	92
Component Inspection (Motor) .....	66	<b>SUNLOAD SENSOR</b> .....	93
<b>B27A2, B27A3, B27A4, B27A5 AIR MIX DOOR MOTOR</b> .....	68	Removal and Installation .....	93
DTC Logic .....	68	<b>INTAKE SENSOR</b> .....	94
Diagnosis Procedure .....	68	Exploded View .....	94
Component Inspection .....	69	Removal and Installation .....	94
<b>B27A6, B27A7, B27A8, B27A9 MODE DOOR MOTOR</b> .....	70		
DTC Logic .....	70		

<b>REFRIGERANT PRESSURE SENSOR</b> .....	<b>95</b>	COMMON ITEM : CONSULT Function (BCM -	
Exploded View .....	95	COMMON ITEM) .....	109
Removal and Installation .....	95		
<b>POWER TRANSISTOR</b> .....	<b>96</b>	<b>AIR CONDITIONER</b> .....	<b>110</b>
Exploded View .....	96	AIR CONDITIONER : CONSULT Function (BCM -	
Removal and Installation .....	96	AIR CONDITIONER) (Manual A/C) .....	110
<b>DOOR MOTOR</b> .....	<b>97</b>	<b>ECU DIAGNOSIS INFORMATION</b> .....	<b>111</b>
Exploded View .....	97	<b>BCM, ECM, IPDM E/R</b> .....	<b>111</b>
<b>INTAKE DOOR MOTOR</b> .....	<b>98</b>	List of ECU Reference .....	111
INTAKE DOOR MOTOR : Removal and Installa-		<b>WIRING DIAGRAM</b> .....	<b>112</b>
tion .....	98	<b>MANUAL AIR CONDITIONING SYSTEM</b> .....	<b>112</b>
<b>MODE DOOR MOTOR</b> .....	<b>98</b>	Wiring Diagram .....	112
MODE DOOR MOTOR : Removal and Installation...	98	<b>BASIC INSPECTION</b> .....	<b>116</b>
<b>AIR MIX DOOR MOTOR</b> .....	<b>99</b>	<b>DIAGNOSIS AND REPAIR WORK FLOW</b> .....	<b>116</b>
AIR MIX DOOR MOTOR : Removal and Installa-		Work Flow .....	116
tion .....	99	<b>OPERATION INSPECTION</b> .....	<b>119</b>
<b>MANUAL AIR CONDITIONING</b>		Work Procedure .....	119
<b>PRECAUTION</b> .....	<b>100</b>	<b>DTC/CIRCUIT DIAGNOSIS</b> .....	<b>121</b>
<b>PRECAUTIONS</b> .....	<b>100</b>	<b>A/C SWITCH</b> .....	<b>121</b>
Precaution for Supplemental Restraint System		Component Function Check .....	121
(SRS) "AIR BAG" and "SEAT BELT PRE-TEN-		Diagnosis Procedure .....	121
SIONER" .....	100	<b>BLOWER FAN ON SIGNAL</b> .....	<b>123</b>
Precautions for Removing of Battery Terminal	100	Component Function Check .....	123
<b>SYSTEM DESCRIPTION</b> .....	<b>101</b>	Diagnosis Procedure .....	123
<b>COMPONENT PARTS</b> .....	<b>101</b>	<b>THERMO CONTROL AMPLIFIER</b> .....	<b>125</b>
Component Part Location .....	101	Component Function Check .....	125
Component Description .....	101	Diagnosis Procedure .....	125
<b>A/C UNIT ASSEMBLY</b> .....	<b>102</b>	<b>DEFROSTER POSITION SIGNAL</b> .....	<b>127</b>
A/C UNIT ASSEMBLY : Thermo Control Amp. ....	102	Component Function Check .....	127
A/C UNIT ASSEMBLY : Blower Motor .....	102	Diagnosis Procedure .....	127
A/C UNIT ASSEMBLY : Blower Fan Resistor .....	102	<b>A/C INDICATOR</b> .....	<b>129</b>
A/C Control .....	102	Diagnosis Procedure .....	129
BCM .....	103	<b>BLOWER MOTOR</b> .....	<b>131</b>
ECM .....	103	Diagnosis Procedure .....	131
IPDM E/R .....	103	Component Inspection (Blower Motor) .....	133
Refrigerant Pressure Sensor .....	103	Component Inspection (Blower Relay) .....	133
Magnet Clutch .....	103	Component Inspection (Blower Fan Resistor) .....	133
<b>SYSTEM</b> .....	<b>104</b>	Component Inspection (Fan Switch) .....	133
System Diagram .....	104	<b>MAGNET CLUTCH</b> .....	<b>135</b>
System Description .....	104	Component Function Check .....	135
Compressor Control .....	104	Diagnosis Procedure .....	135
Door Control .....	105	<b>SYMPTOM DIAGNOSIS</b> .....	<b>136</b>
<b>OPERATION</b> .....	<b>108</b>	<b>MANUAL AIR CONDITIONING SYSTEM</b> .....	<b>136</b>
Switch Name and Function .....	108	Symptom Table .....	136
<b>DIAGNOSIS SYSTEM (BCM)</b> .....	<b>109</b>	<b>INSUFFICIENT COOLING</b> .....	
Description .....	109		
<b>COMMON ITEM</b> .....	<b>109</b>		

Description .....	138	Exploded View .....	144
Diagnosis Procedure .....	138	Removal and Installation .....	144
<b>INSUFFICIENT HEATING .....</b>	<b>139</b>	<b>BLOWER FAN RESISTOR .....</b>	<b>145</b>
Description .....	139	Exploded View .....	145
Diagnosis Procedure .....	139	Removal and Installation .....	145
<b>COMPRESSOR DOES NOT OPERATE .....</b>	<b>140</b>	<b>DOOR CABLE .....</b>	<b>146</b>
Description .....	140	Exploded View .....	146
Diagnosis Procedure .....	140	<b>INTAKE DOOR CABLE .....</b>	<b>147</b>
<b>REMOVAL AND INSTALLATION .....</b>	<b>142</b>	INTAKE DOOR CABLE : Removal and Installation	. 147
<b>A/C CONTROL .....</b>	<b>142</b>	<b>MODE DOOR CABLE .....</b>	<b>147</b>
Exploded View .....	142	MODE DOOR CABLE : Removal and Installation.	148
Removal and Installation .....	142	<b>AIR MIX DOOR CABLE .....</b>	<b>148</b>
<b>THERMO CONTROL AMPLIFIER .....</b>	<b>143</b>	AIR MIX DOOR CABLE : Removal and Installation	. 148
Removal and Installation .....	143		
<b>REFRIGERANT PRESSURE SENSOR .....</b>	<b>144</b>		

PRECAUTION

PRECAUTIONS

Precaution for Supplemental Restraint System (SRS) "AIR BAG" and "SEAT BELT PRE-TENSIONER"

INFOID:000000009754294

The Supplemental Restraint System such as "AIR BAG" and "SEAT BELT PRE-TENSIONER", used along with a front seat belt, helps to reduce the risk or severity of injury to the driver and front passenger for certain types of collision. This system includes seat belt switch inputs and dual stage front air bag modules. The SRS system uses the seat belt switches to determine the front air bag deployment, and may only deploy one front air bag, depending on the severity of a collision and whether the front occupants are belted or unbelted. Information necessary to service the system safely is included in the "SRS AIR BAG" and "SEAT BELT" of this Service Manual.

**WARNING:**

Always observe the following items for preventing accidental activation.

- To avoid rendering the SRS inoperative, which could increase the risk of personal injury or death in the event of a collision that would result in air bag inflation, all maintenance must be performed by an authorized NISSAN/INFINITI dealer.
- Improper maintenance, including incorrect removal and installation of the SRS, can lead to personal injury caused by unintentional activation of the system. For removal of Spiral Cable and Air Bag Module, see "SRS AIR BAG".
- Never use electrical test equipment on any circuit related to the SRS unless instructed to in this Service Manual. SRS wiring harnesses can be identified by yellow and/or orange harnesses or harness connectors.

PRECAUTIONS WHEN USING POWER TOOLS (AIR OR ELECTRIC) AND HAMMERS

**WARNING:**

Always observe the following items for preventing accidental activation.

- When working near the Air Bag Diagnosis Sensor Unit or other Air Bag System sensors with the ignition ON or engine running, never use air or electric power tools or strike near the sensor(s) with a hammer. Heavy vibration could activate the sensor(s) and deploy the air bag(s), possibly causing serious injury.
- When using air or electric power tools or hammers, always switch the ignition OFF, disconnect the battery, and wait at least 3 minutes before performing any service.

Precautions for Removing of Battery Terminal

INFOID:0000000010286675

- When removing the 12V battery terminal, turn OFF the ignition switch and wait at least 30 seconds.

**NOTE:**

ECU may be active for several tens of seconds after the ignition switch is turned OFF. If the battery terminal is removed before ECU stops, then a DTC detection error or ECU data corruption may occur.

- For vehicles with the 2-batteries, be sure to connect the main battery and the sub battery before turning ON the ignition switch.

**NOTE:**

If the ignition switch is turned ON with any one of the terminals of main battery and sub battery disconnected, then DTC may be detected.

- After installing the 12V battery, always check "Self Diagnosis Result" of all ECUs and erase DTC.

**NOTE:**

The removal of 12V battery may cause a DTC detection error.

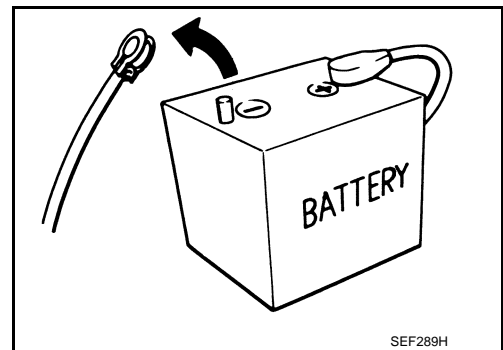

A  
B  
C  
D  
E  
F  
G  
H  
HAC  
J  
K  
L  
M  
N  
O  
P

# COMPONENT PARTS

< SYSTEM DESCRIPTION >

[AUTOMATIC AIR CONDITIONING]

## SYSTEM DESCRIPTION

### COMPONENT PARTS

#### Component Parts Location

INFOID:000000009754295

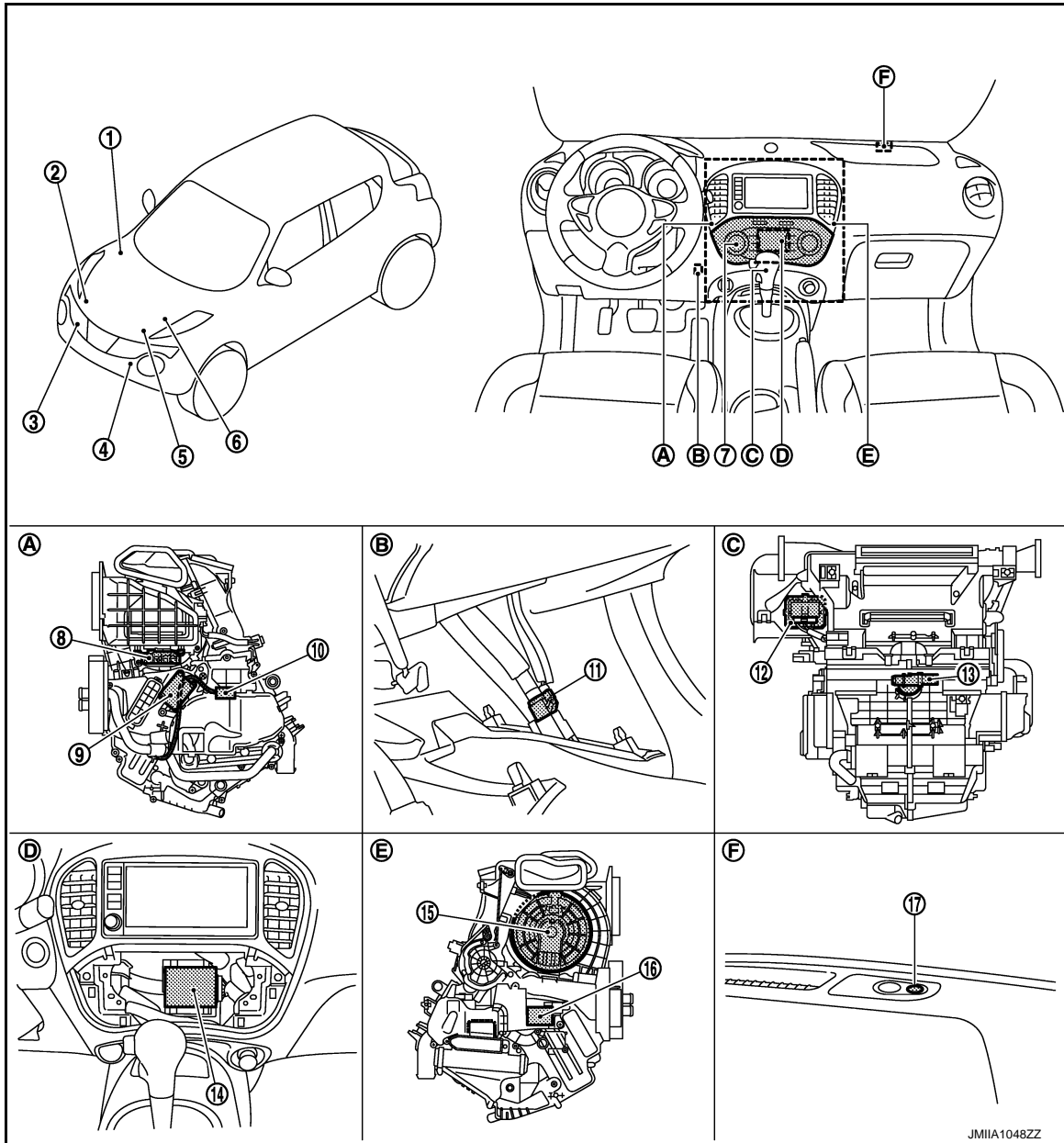

- |  |  |   |
|--|--|---|
| 1. BCM<br>Refer to <a href="#">BCS-6, "BODY CONTROL SYSTEM : Component Parts Location"</a> . | 2. Magnet clutch   | 3. Refrigerant pressure sensor  |
| 4. Ambient sensor  | 5. ECM<br>Refer to <a href="#">EC-14, "ENGINE CONTROL SYSTEM : Component Parts Location"</a> . | 6. IPDM E/R<br>Refer to <a href="#">PCS-5, "Component Parts Location"</a> . |
| 7. Multi display unit  | 8. Intake door motor   | 9. Air mix door motor   |
| 10. Intake sensor  | 11. In-vehicle sensor  | 12. Power transistor  |
| 13. Aspirator  | 14. A/C auto amp.  | 15. Blower motor  |
| 16. Mode door motor  | 17. Sunload sensor   |   |

JMIA1048ZZ

# COMPONENT PARTS

< SYSTEM DESCRIPTION >

[AUTOMATIC AIR CONDITIONING]

- |                                   |   |                                   |
|-----------------------------------|---|-----------------------------------|
| A. Left side of A/C unit assembly | B. Instrument lower panel LH is removed | C. Back side of A/C unit assembly |
| D. Multi display unit is removed  | E. Right side of A/C unit assembly      | F. Right side of switch panel     |

## Component Description

INFOID:000000009754296

Component	Description	
A/C unit assembly	Aspirator	<a href="#">HAC-7</a>
	Intake sensor	<a href="#">HAC-7</a>
	Air mix door motor	<a href="#">HAC-7</a>
	Mode door motor	<a href="#">HAC-8</a>
	Intake door motor	<a href="#">HAC-8</a>
	Blower motor	<a href="#">HAC-8</a>
	Power transistor	<a href="#">HAC-8</a>
Multi display unit	<a href="#">HAC-9</a>	
A/C auto amp.	<a href="#">HAC-9</a>	
BCM	<a href="#">HAC-9</a>	
ECM	<a href="#">HAC-9</a>	
IPDM E/R	<a href="#">HAC-9</a>	
Ambient sensor	<a href="#">HAC-9</a>	
In-vehicle sensor	<a href="#">HAC-9</a>	
Sunload sensor	<a href="#">HAC-9</a>	
Refrigerant pressure sensor	<a href="#">HAC-9</a>	
Magnet clutch	<a href="#">HAC-10</a>	

## A/C UNIT ASSEMBLY

### A/C UNIT ASSEMBLY : Aspirator

INFOID:000000009754297

The aspirator generates the vacuum by the air blown from the A/C unit assembly and draws the air of the passenger room to the in-vehicle sensor area via the aspirator duct.

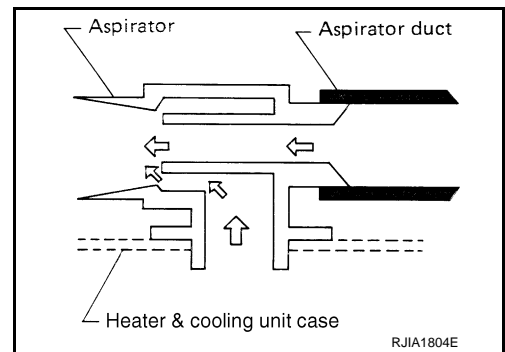

### A/C UNIT ASSEMBLY : Intake Sensor

INFOID:000000009754298

Intake sensor measures temperature of evaporator fin temperature. The sensor uses a thermistor which is sensitive to the change in temperature. The electrical resistance of the thermistor decreases as temperature increases.

### A/C UNIT ASSEMBLY : Air Mix Door Motor

INFOID:000000009754299

- The step motor system is adopted for air mix door motor.
- When a drive signal is input from A/C auto amp. to door motor, a step motor built into the door motor rotates according to the drive signal, and then stops at the target door position. Refer to [HAC-15, "Door Control"](#).
- Rotation of motor is transmitted to air mix door (upper air mix door and lower air mix door) by rod and lever. Air flow temperature is switched.

# COMPONENT PARTS

< SYSTEM DESCRIPTION >

[AUTOMATIC AIR CONDITIONING]

## A/C UNIT ASSEMBLY : Mode Door Motor

INFOID:000000009754300

- The step motor system is adopted for mode door motor.
- When a drive signal is input from A/C auto amp. to door motor, a step motor built into the door motor rotates according to the drive signal, and then stops at the target door position. Refer to [HAC-15, "Door Control"](#).
- Rotation of motor is transmitted to mode door (center ventilator and defroster door, sub defroster door, side ventilator door, and foot door) by link, rod, and lever. Air outlet is switched.

## A/C UNIT ASSEMBLY : Intake Door Motor

INFOID:000000009754301

- Intake door motor consists of motor that drives door and PBR (Potentio Balance Register) that detects door position.
- Motor operates intake door according to control signal from A/C auto amp. Refer to [HAC-15, "Door Control"](#).
- Rotation of motor is transmitted to intake door by lever. Air inlet is switched.
- PBR (Potentio Balance Register) transmits PBR feedback signal to A/C auto amp. according to motor position.
- According to PBR feedback signal, A/C auto amp. monitors that motor is in an appropriate door position.

## A/C UNIT ASSEMBLY : Blower Motor

INFOID:000000009754302

- The blower motor utilizes a brush-less motor with a rotating magnet.
- Quietness is improved over previous motors where the brush was the point of contact and the coil rotated.

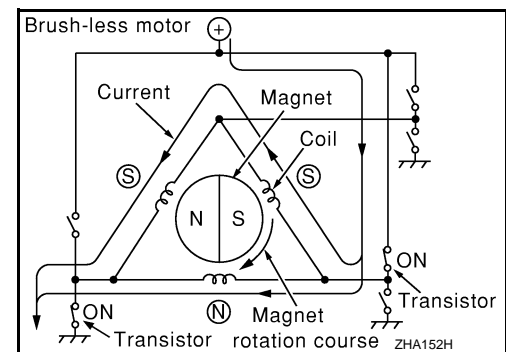
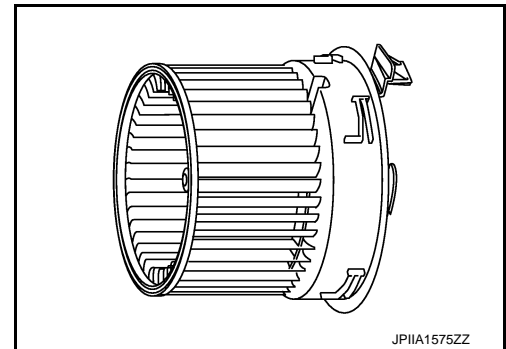

## A/C UNIT ASSEMBLY : Power Transistor

INFOID:000000009754303

- Power transistor, that uses MOS field effect transistor, is adopted for blower motor speed control.

### NOTE:

MOS field effect transistor is a transistor for which the gate portion is composed of a metal electrode on an oxide layer of semiconductor. Field effect transistor is controlled by voltage, while ordinary transistor is controlled by current. Electrode of field effect transistor is called source, drain, or gate, while electrode of ordinary transistor is called emitter, collector, or base.

- Power transistor continuously controls voltage to blower motor, according to gate voltage from A/C auto amp.
- This power transistor does not require a HI relay even when the maximum voltage is applied to blower motor at HI status, because voltage drop is nominal.

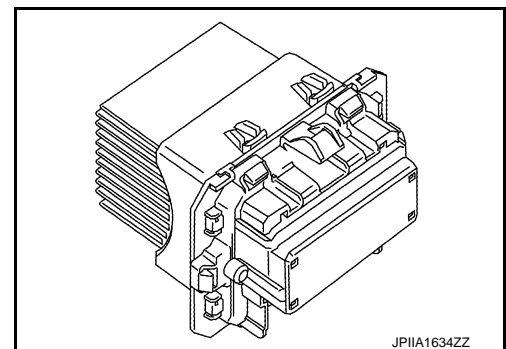



# COMPONENT PARTS

< SYSTEM DESCRIPTION >

[AUTOMATIC AIR CONDITIONING]

## Multi Display Unit

INFOID:000000009754304

- Multi display unit integrates display and operation switches.
- Operation of each switch (A/C operation signal) and setting status (A/C ECO setting signal and ECO mode signal) are transmitted to A/C auto amp. via CAN communication.
- Operation status of air conditioning system is indicated in the display according to A/C display signal that is received from A/C auto amp.

## A/C Auto Amp.

INFOID:000000009754305

A/C auto amp. controls automatic air conditioning system by inputting and calculating signals from each sensor and each switch. A/C auto amp. has self-diagnosis function. Diagnosis of automatic air conditioning system can be performed quickly.

## BCM

INFOID:000000009754306

BCM transmits A/C ON signal and blower fan ON signal from A/C auto amp. to ECM via CAN communication line.

## ECM

INFOID:000000009754307

- ECM, when receiving A/C ON signal and blower fan ON signal from BCM, transmits A/C compressor request signal to IPDM E/R via CAN communication according to status of the engine and refrigerant pressure.
- ECM transmits engine coolant temperature signal to A/C auto amp. via CAN communication line.

## IPDM E/R

INFOID:000000009754308

A/C relay is integrated in IPDM E/R. IPDM E/R operates A/C relay when A/C compressor request signal is received from ECM via CAN communication line.

## Ambient Sensor

INFOID:000000009754309

Ambient sensor measures ambient air temperature. The sensor uses a thermistor which is sensitive to the change in temperature. The electrical resistance of the thermistor decreases as temperature increases.

## In-vehicle Sensor

INFOID:000000009754310

In-vehicle sensor measures temperature of intake air that flows through aspirator to passenger room. The sensor uses a thermistor which is sensitive to the change in temperature. The electrical resistance of the thermistor decreases as temperature increases.

## Sunload Sensor

INFOID:000000009754311

Sunload sensor measures sunload amount. This sensor converts sunload amount to voltage signal by photo-diode and transmits to A/C auto amp.

## Refrigerant Pressure Sensor

INFOID:000000009754312

### DESCRIPTION

- The refrigerant pressure sensor converts high-pressure side refrigerant pressure into voltage and outputs it to ECM.
- ECM operates cooler cycle protection and cooling fan speed control according to voltage value that is input.

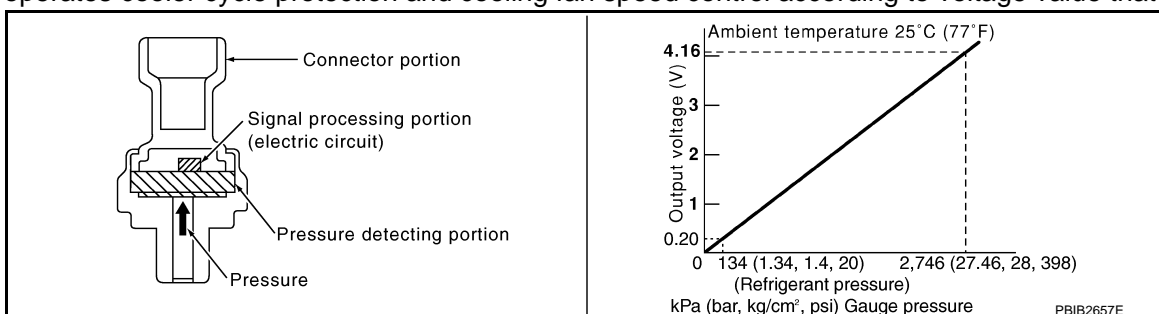

### STRUCTURE AND OPERATION

A

B

C

D

E

F

G

H

HAC

J

K

L

M

N

O

P

## COMPONENT PARTS

< SYSTEM DESCRIPTION >

[AUTOMATIC AIR CONDITIONING]

- The refrigerant pressure sensor is a capacitance type sensor. It consists of a pressure detection area and a signal processing area.
- The pressure detection area, which is a variable capacity condenser, changes internal static capacitance according to pressure force.
- The signal processing area detects the static capacitance of the pressure detection area, converts the static capacitance into a voltage value, and transmits the voltage value to ECM.

### Magnet Clutch

INFOID:000000009754313

Compressor is driven by the magnet clutch which is magnetized by electric power supply.

SYSTEM

System Diagram

INFOID:000000009754314

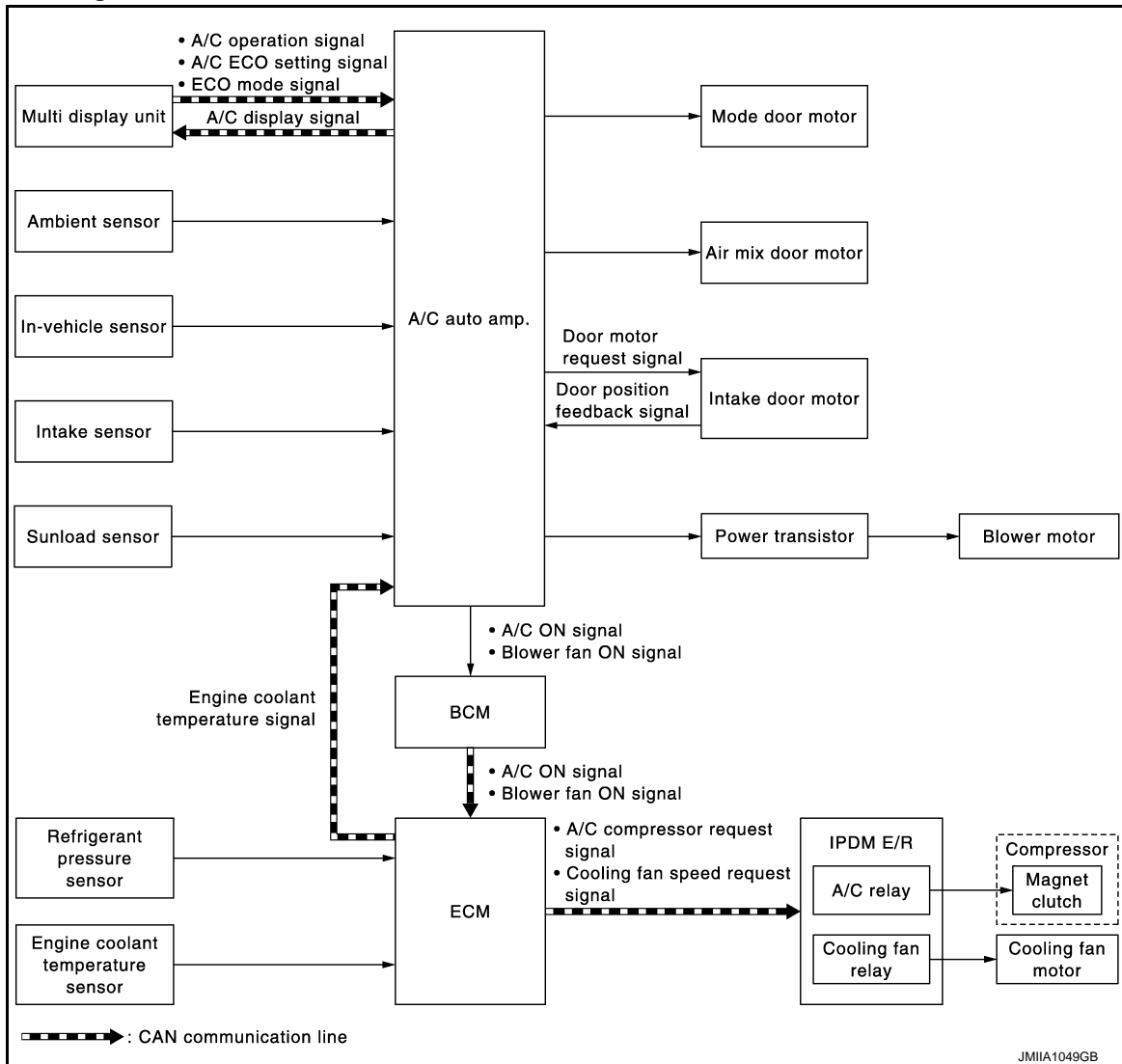

A  
B  
C  
D  
E  
F  
G  
H  
I  
J  
K  
L

HAC

System Description

INFOID:000000009754315

DESCRIPTION

- Automatic air conditioning system is controlled by each function of A/C auto amp., BCM, ECM and IPDM E/R.
- Each operation of air conditioning system is transmitted from multi display unit via CAN communication. A/C auto amp. transmits each type of indication information to multi display unit via CAN communication. Multi display unit displays each type of indication information that is received.

CONTROL BY A/C AUTO AMP.

- [HAC-12, "Temperature Control"](#)
- [HAC-13, "Air Outlet Control"](#)
- [HAC-13, "Air Flow Control"](#)
- [HAC-14, "Air Inlet Control"](#)
- [HAC-14, "Compressor Control"](#)
- [HAC-15, "Door Control"](#)
- [HAC-18, "ECO Mode Control"](#)
- Correction for input value

Ambient temperature correction  
 - The A/C auto amp. inputs the temperature detected with the ambient sensor as the ambient temperature.

# SYSTEM

## < SYSTEM DESCRIPTION >

## [AUTOMATIC AIR CONDITIONING]

- Perform the correction of the temperature detected with the ambient sensor for air conditioning control.
- Select and use the initial value of ambient temperature data depending on the engine coolant temperature when turning the ignition switch from OFF to ON. Use the detection temperature of the ambient sensor at low coolant temperature [less than approximately 56°C (133°F)]. Use the memory data (before the ignition switch is OFF) when the engine is warming up [approximately 56°C (133°F) or more].
- Do not perform the correction of the ambient temperature when the detection temperature of the ambient temperature is less than approximately -20°C (-4°F).

### Passenger room temperature correction

- The A/C auto amp. inputs the temperature detected with the in-vehicle sensor as the passenger room temperature.
- Perform the correction of the temperature detected with the in-vehicle sensor for air conditioning control.
- The A/C auto amp. performs the correction so that the recognition passenger room temperature changes depending on the difference between the detected passenger room temperature and the recognition passenger room temperature. If the difference is large, the changing is early. The changing becomes slow as the difference becomes small.

### Intake temperature correction

- The A/C auto amp. inputs the temperature detected with the intake sensor as the intake temperature.
- Perform the correction of the temperature detected with the intake sensor for air conditioning control.
- The A/C auto amp. performs the correction so that the recognition intake temperature changes depending on the difference between the detected intake temperature and the recognition intake temperature. If the difference is large, the changing is early. The changing becomes slow as the difference becomes small.

### Sunload amount correction

- The A/C auto amp. inputs the sunload amount detected with the sunload sensor.
- Perform the correction of the sunload amount detected with the sunload sensor for air conditioning control.
- When the sunload amount suddenly changes, for example when entering a tunnel, perform the correction so that the recognition sunload amount of the A/C auto amp. changes slowly.

### Set temperature correction

- A/C auto amp. controls The A/C auto amp. performs the correction to the target temperature set by the temperature control switch so as to match the temperature felt by the passengers depending on the ambient temperature detected with the ambient sensor and controls it so that the interior air temperature is always the most suitable.

## CONTROL BY BCM

- [HAC-14. "Compressor Control"](#)

## CONTROL BY ECM

- [HAC-14. "Compressor Control"](#)
- Cooling fan control. Refer to [EC-52. "COOLING FAN CONTROL : System Description"](#).

## CONTROL BY IPDM E/R

- [HAC-14. "Compressor Control"](#)
- Cooling fan control. Refer to [PCS-10. "POWER CONTROL SYSTEM : System Description"](#).

## Temperature Control

INFOID:000000009754316

- When ignition switch is in the ON position, A/C auto amp. always automatically controls temperature regardless of air conditioner operational state.
- A/C auto amp. calculates the target air mix door opening angle depending on set temperature, in-vehicle temperature, ambient temperature, and sunload.
- Air mix door is controlled depending on the comparison of current air mix door opening angle and target air mix door opening angle.
- Regardless of in-vehicle temperature, ambient temperature, and sunload, air mix door is fixed at the fully cold position when set temperature is 18°C (60°F), and at the fully hot position when set temperature is 32°C (90°F).

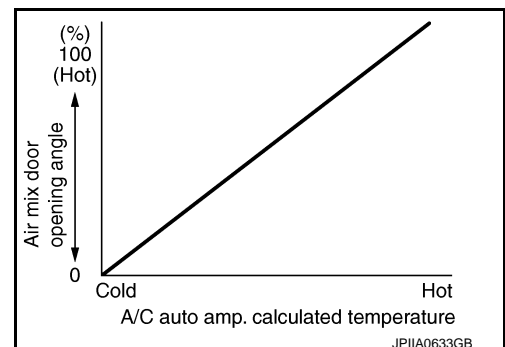

# SYSTEM

< SYSTEM DESCRIPTION >

[AUTOMATIC AIR CONDITIONING]

## Air Outlet Control

INFOID:000000009754317

- While air outlet is in automatic control, A/C auto amp. selects the mode door position depending on a target air mix door angle and outlet air temperature calculated from sunload.
- If ambient temperature is excessively low, D/F is selected to prevent windshield fogging when air outlet is set to FOOT.

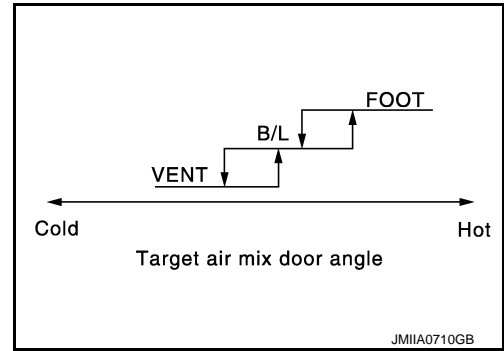

## Air Flow Control

INFOID:000000009754318

### DESCRIPTION

- A/C auto amp. changes gate voltage of power transistor and controls air flow continuously. When air flow is increased, voltage of blower motor gradually increases to prevent a sudden increase in air flow.
- In addition to manual control and automatic control, air flow control is composed of starting fan speed control, low coolant temperature starting control, and blower speed control at door motor operation.

### AUTOMATIC AIR FLOW CONTROL

- A/C auto amp. decides target air flow depending on target air mix door opening angle.
- A/C auto amp. changes voltage of blower motor and controls air flow continuously so that air flow matches to target air flow.
- When air outlet is VENT or B/L, the minimum air flow is changed depending on sunload.

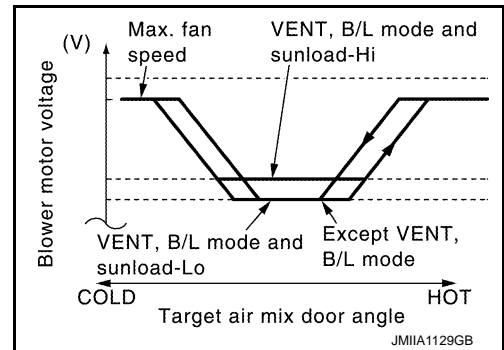

### STARTING FAN SPEED CONTROL

When blower motor is activated, A/C auto amp. gradually increases voltage of blower motor to prevent a sudden increase in discharge air flow. (T1 – T2 = approximately 8 seconds)

#### NOTE:

Do not perform the starting air flow control when the discharge outlet is set to DEF.

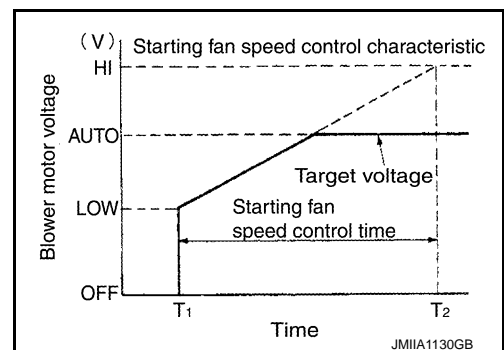

### LOW COOLANT TEMPERATURE STARTING CONTROL

A  
B  
C  
D  
E  
F  
G  
H  
HAC  
J  
K  
L  
M  
N  
O  
P

# SYSTEM

## < SYSTEM DESCRIPTION >

## [AUTOMATIC AIR CONDITIONING]

If the engine coolant temperature is 56°C (133°F) or less, to prevent a cold discharged air flow, A/C auto amp. suspends blower motor activation for the maximum 150 seconds depending on target air mix door opening angle. After this, voltage of blower motor is increased gradually, and blower motor is activated.

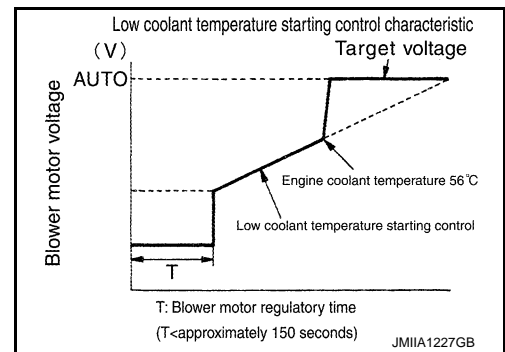

### FAN SPEED CONTROL AT DOOR MOTOR OPERATION

When mode door motor is activated while air flow is more than the specified value, A/C auto amp. reduces temporarily fan speed so that mode door moves smoothly.

### HIGH IN-TEMPERATURE STARTING CONTROL

When evaporator temperature is high [intake air temperature sensor value is 35°C (95°F) or more], to prevent a hot discharged air flow, A/C auto amp. suspends blower motor activation for approximately 3 seconds so that evaporator is cooled by refrigerant.

### Air Inlet Control

INFOID:000000009754319

- While air inlet is in automatic control, A/C auto amp. selects air inlet (fresh air intake, 20% fresh air intake, or recirculation) depending on set temperature, in-vehicle temperature, and ambient temperature.
- Air inlet is fixed to 80% FRE, only when the conditions are satisfied as follows:
  - Air inlet is FOOT or D/F
  - Ambient temperature is 2°C (36°F) or less
  - Maximum fan speed

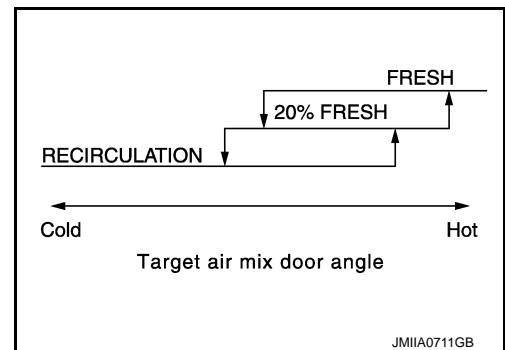

### Compressor Control

INFOID:000000009754320

#### DESCRIPTION

- When the compressor activation condition is satisfied while blower motor is activated, A/C auto amp. transmits A/C ON signal and blower fan ON signal to BCM.
- BCM transmits the A/C ON signal and blower fan ON signal to ECM via CAN communication line. Refer to [BCS-12, "SIGNAL BUFFER SYSTEM : System Description"](#).
- ECM judges the conditions of each sensor (Refrigerant pressure sensor signal, accelerator position signal, etc.), and transmits the A/C compressor request signal to IPDM E/R via CAN communication line.
- By receiving the A/C compressor request signal from ECM, IPDM E/R turns the A/C relay to ON, and activates the compressor. Refer to [PCS-7, "RELAY CONTROL SYSTEM : System Description"](#).

#### CONTROL BY A/C AUTO AMP.

##### Low Temperature Protection Control

When intake sensor detects that evaporator fin temperature is 2°C (36°F) or less, A/C auto amp. requests ECM to turn the compressor OFF, and stops the compressor.

When the air temperature returns to 3.5°C (38°F) or more, the compressor is activated.

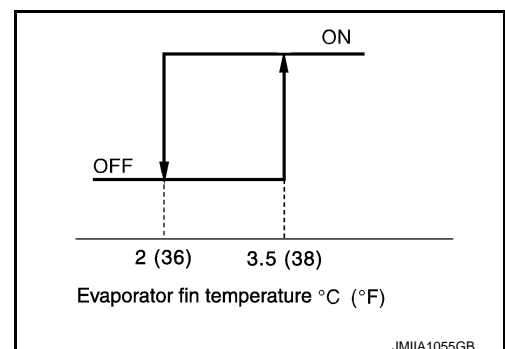

# SYSTEM

< SYSTEM DESCRIPTION >

[AUTOMATIC AIR CONDITIONING]

## CONTROL BY ECM

### Compressor Protection Control at Pressure Malfunction

When the high-pressure side value that is detected by refrigerant pressure sensor is as per the following state, ECM requests IPDM E/R to turn A/C relay OFF and stops the compressor.

- 3.12 MPa (31.82 kg/cm<sup>2</sup>, 452.4 psi) or more (When the engine speed is less than 1,500 rpm)
- 2.74 MPa (27.95 kg/cm<sup>2</sup>, 397.3 psi) or more (When the engine speed is 1,500 rpm or more)
- 0.14 MPa (1.43 kg/cm<sup>2</sup>, 20.3 psi) or less

### Compressor Oil Circulation Control

When the engine starts while the engine coolant temperature is 56°C (133°F) or less, ECM activates the compressor for approximately 6 seconds and circulates the compressor oil once.

### Air Conditioning Cut Control

When the engine condition is high load, ECM transmit A/C relay OFF request to IPDM E/R, and stops the compressor. Refer to [EC-50, "AIR CONDITIONING CUT CONTROL : System Description"](#).

## Door Control

INFOID:000000009754321

### DOOR MOTOR CONTROL

- A/C auto amp. receives the detection data from each sensor.
- Intake door motor, when receiving control signal from A/C auto amp. moves intake door to the appropriate position based on the door position detection signal of each PBR (Potentio Balance Resistor).
- Each motor of air mix and mode, when receiving drive signal from A/C auto amp., moves each door to the appropriate position according to drive signal.

### DRIVE METHOD OF STEPPING MOTOR TYPE MOTOR

- Stepping motor type motor is driven by 4 pieces of drive coil that are sequentially excited.
- Direction of rotation is changeable by recomposing pattern of excitation.

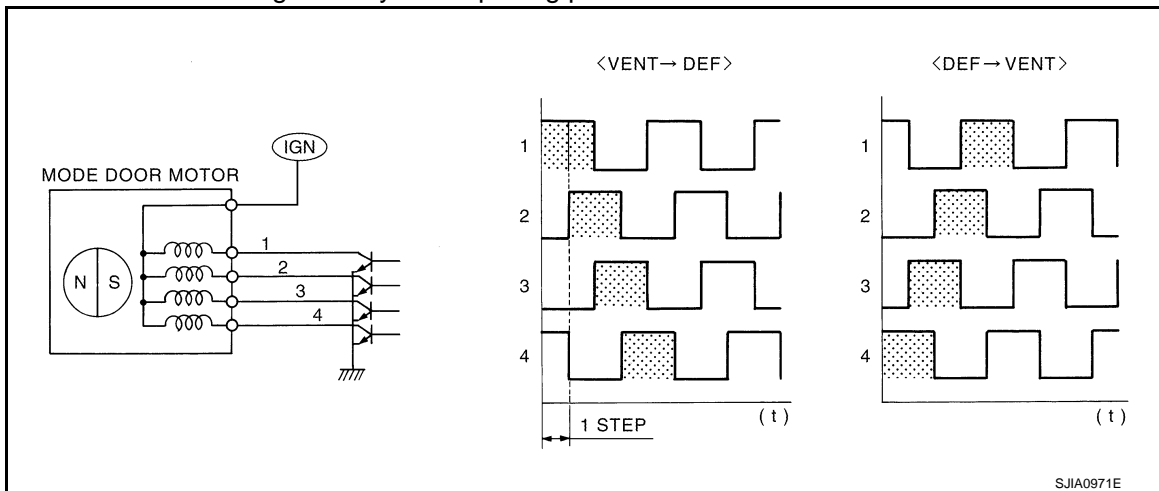

## SWITCH AND THEIR CONTROL FUNCTION

A  
B  
C  
D  
E  
F  
G  
H  
J  
K  
L  
M  
N  
O  
P

HAC

# SYSTEM

< SYSTEM DESCRIPTION >

[AUTOMATIC AIR CONDITIONING]

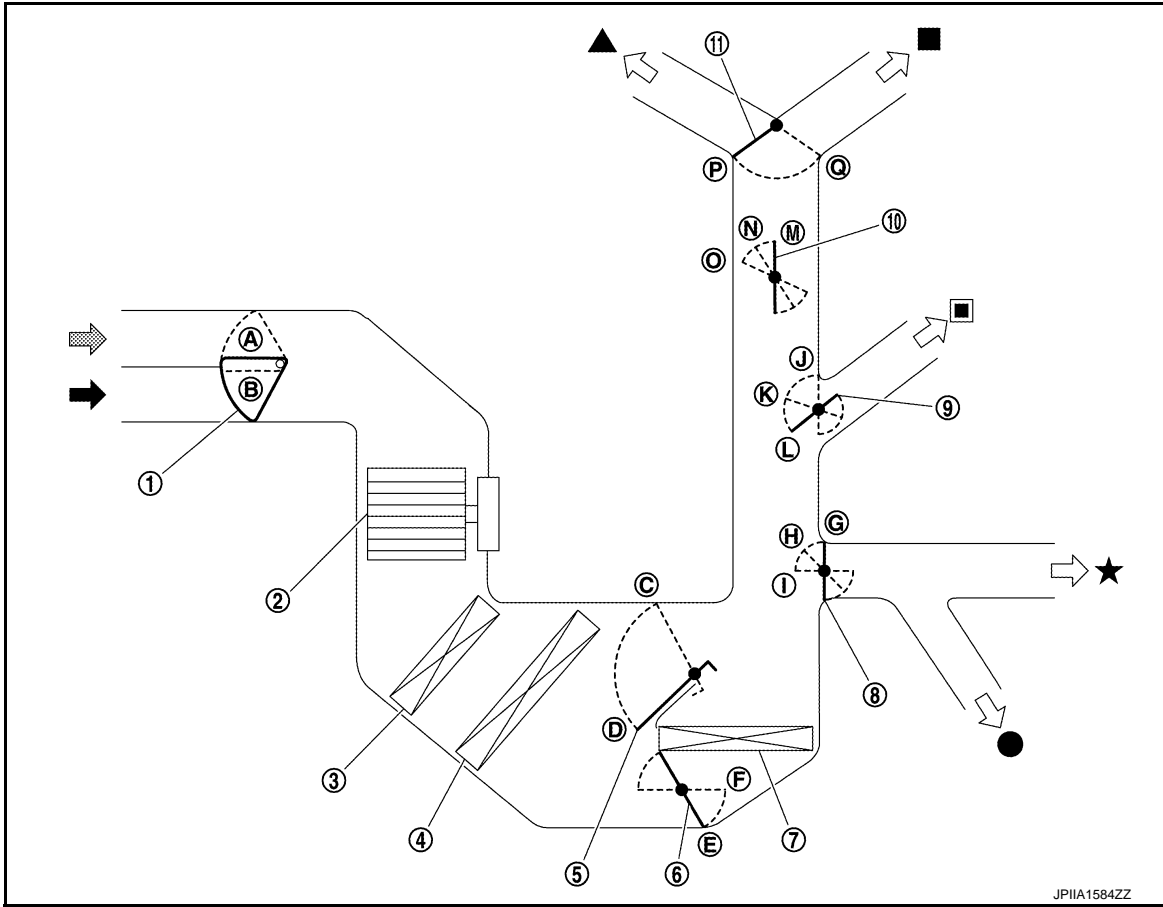

JPIIA1584ZZ

- |                        |  |                                |
|------------------------|--|--------------------------------|
| 1. Intake door         | 2. Blower motor                          | 3. In-cabin microfilter filter |
| 4. Evaporator          | 5. Upper air mix door                    | 6. Lower air mix door          |
| 7. Heater core         | 8. Foot door                             | 9. Side ventilator door        |
| 10. Sub defroster door | 11. Center ventilator and defroster door |                                |
| ← Fresh air intake     | ← Recirculation air                      | ▲ Defroster                    |
| ■ Center ventilator    | ■ Side ventilator                        | ★ Foot                         |
| ● Rear foot*           |  |                                |

\*: Models for Canada

Switch/dial position		Door position					
		Center ventilator and defroster door	Sub defroster door	Side ventilator door	Foot door	Intake door	Upper air mix door
AUTO switch	AUTO	AUTO					



# SYSTEM

< SYSTEM DESCRIPTION >

[AUTOMATIC AIR CONDITIONING]

Switch/dial position				Door position						
				Center ventilator and defroster door	Sub defroster door	Side ventilator door	Foot door	Intake door	Upper air mix door	Lower air mix door
MODE switch	VENT			P	M	L	G	—	—	—
	B/L				N	K	H			
	FOOT			Q	O	J	I			
	D/F				N		G			
DEF switch					M					
Intake switch								A		
								B		
Temperature control dial		Full cold 18°C (60°F)		—	—	—	—		D	E
		18.5°C (61°F) – 31.5°C (89°F)						—	AUTO	AUTO
		Full hot 32°C (90°F)							C	F
OFF switch				Q	O	J	I	B	—	—

A  
B  
C  
D  
E  
F  
G  
H  
J  
K  
L  
M  
N  
O  
P

HAC

## AIR DISTRIBUTION

Models except for Canada

Discharge air flow				
MODE/DEF setting position	Air outlet/distribution			
	Ventilator		Foot	Defroster
	Center	Side		
	52.6%	47.3%	—	—
	34.0%	27.7%	38.4%	—
	—	19.1%	57.9%	23.0%
	—	13.5%	42.4%	44.1%
	—	16.3%	—	83.8%



Models for Canada

Discharge air flow					
MODE/DEF setting position	Air outlet/distribution				
	Ventilator		Foot		Defroster
	Center	Side	Front	Rear	
	52.6%	47.3%	—	—	—
	28.2%	25.9%	29.6%	16.3%	—
	—	16.3%	43.0%	21.0%	19.7%

# SYSTEM

< SYSTEM DESCRIPTION >

[AUTOMATIC AIR CONDITIONING]

Discharge air flow					
MODE/DEF setting position	Air outlet/distribution				
	Ventilator		Foot		Defroster
	Center	Side	Front	Rear	
	—	12.2%	33.1%	16.3%	38.4%
	—	16.3%	—	—	83.8%

## ECO Mode Control

INFOID:000000009754322

### DESCRIPTION

- A/C auto amp. receives operation status of each switch (A/C operation signal), D-MODE setting status (ECO mode signal), and “CLIMATE ECO” setting status (A/C ECO setting signal) from multi display unit via CAN communication.
- A/C auto amp. operates air conditioning system in ECO mode, when D-MODE on multi display unit is set to ECO mode while air conditioning system is in automatic control.

#### NOTE:

- For setting procedure of D-MODE, refer to [AV-156. "INTEGRATED CONTROL SYSTEM : System Description"](#).
- Activation or deactivation of ECO mode can be changed using multi display unit setting function (“CLIMATE ECO”). For setting procedure, refer to [AV-156. "INTEGRATED CONTROL SYSTEM : System Description"](#).

### CONTROL OUTLINE

During ECO mode operation, A/C auto amp. changes air flow and control characteristics of air inlet, within a range that may not spoil the comfort level, lowers operation ratio of compressor, and reduces the electrical load. This reduces engine load and improved fuel economy. Refer to the following items for details of each control.

#### Air Flow Control

- A/C auto amp. increases voltage to power transistor gate compared to ordinary operation and reduces voltage to blower motor. This reduces air flow.
- Since air flow is reduced, the amount of air that passes evaporator is reduced. Increase of evaporator temperature can be moderated. Evaporator temperature is easily shifted to temperature control range for low temperature protection control. Operation ratio of evaporator is reduced.
- Since air flow is reduced, the electrical load is reduced. Alternator power output can be moderated.

#### Air Inlet Control

- In the following conditions, A/C auto amp. controls air inlet and increases recirculation air mixing ratio compared to ordinary operation.
  - Ambient temperature: 25°C (77°F) or more
  - Temperature setting: Any temperature other than full cold [18°C (60°F)] or full hot [32°C (90°F)]
  - Air outlet: In automatic control
  - Air flow: In automatic control
  - Air inlet: In automatic control or in fresh air intake mode by manual control
  - A/C switch: ON
- By increasing recirculation air mixing ratio, cooled air in passenger room is circulated in larger amount than during ordinary operation. Air temperature blowing to evaporator is maintained at a low level. Evaporator temperature increase can be moderated. Evaporator temperature is easily shifted to temperature control range for low temperature protection control. Operation ratio of evaporator is reduced.

## Fail-safe

INFOID:000000009754323

### FAIL-SAFE FUNCTION

If a communication error exists between the A/C auto amp. and multi display unit for 2 seconds or longer, air conditioning is controlled under the following conditions:

- A/C display** : OFF
- Set temperature** : Setting before communication error occurs
- Air outlet** : Automatic control

# SYSTEM

< SYSTEM DESCRIPTION >

[AUTOMATIC AIR CONDITIONING]

**Air flow** : Automatic control  
**Air inlet** : Fresh air intake (FRE)  
**A/C switch** : ON

A

B

C

D

E

F

G

H

**HAC**

J

K

L

M

N

O

P

## OPERATION

### Switch Name and Function

INFOID:00000009754324

### OPERATION AND DISPLAY

#### A/C Display (Display in Multi Display Unit)

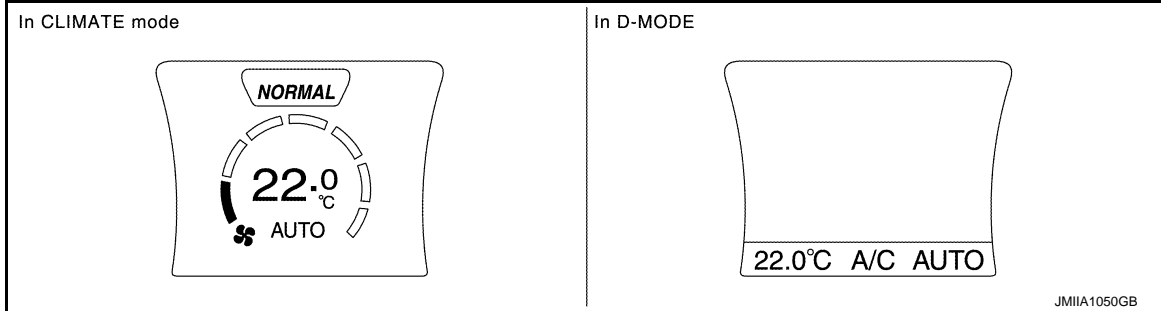

- Air conditioning system operation status is indicated on display in multi display unit. Indication of air conditioning system varies according to display mode of multi display unit. For changing procedure of display mode, refer to [AV-156, "INTEGRATED CONTROL SYSTEM : System Description"](#).
- In CLIMATE mode: Operation status of air conditioning system (setting temperature, air flow, and "AUTO"\*1) is indicated on display when air conditioning system is turned ON. Setting temperature is indicated on display when MODE switch is pressed while air conditioning system is OFF.
- In D-MODE: Operation status of air conditioning system (setting temperature, A/C switch, and "AUTO"\*2) is indicated on lower portion of display when air conditioning system is turned ON. Setting temperature is indicated on display when MODE switch is pressed while air conditioning system is OFF.

**NOTE:**

\*1: AUTO is indicated when both air flow and air outlet are in automatic control.

\*2: Air Flow is indicated when air flow or air outlet is in manual control.

#### A/C Controller (Multi Display Unit)

Operation procedure of air conditioning system varies depending on display mode of multi display unit. For changing procedure of display mode, refer to [AV-156, "INTEGRATED CONTROL SYSTEM : System Description"](#).

- In CLIMATE mode: All operations of air conditioning system are possible.

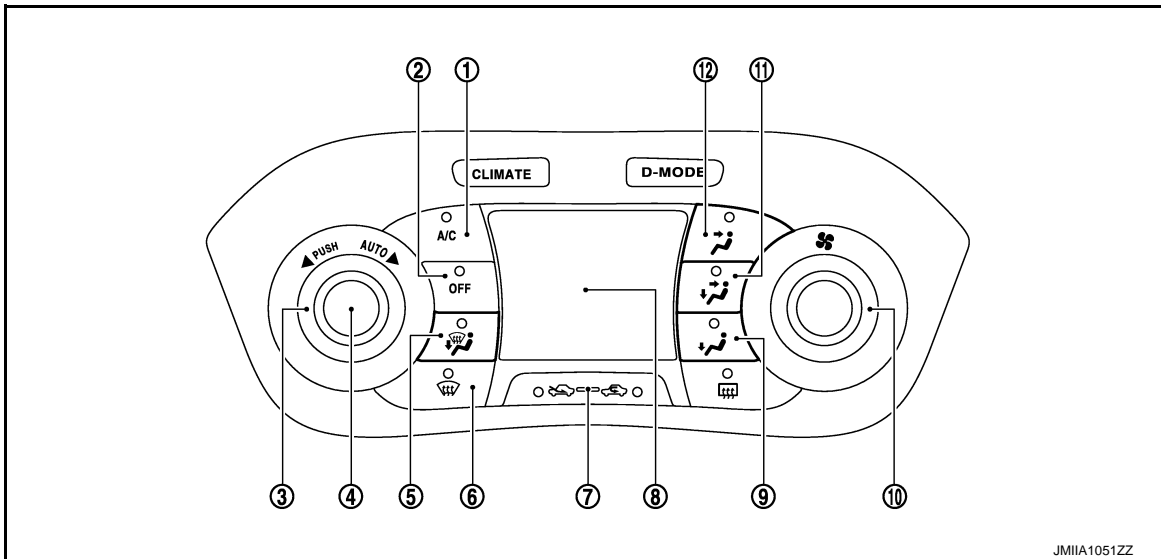

- |                      |                       |                             |
|----------------------|-----------------------|-----------------------------|
| 1. A/C switch        | 2. OFF switch         | 3. Temperature control dial |
| 4. AUTO switch       | 5. MODE switch (D/F)  | 6. DEF switch               |
| 7. Intake switch     | 8. Display            | 9. MODE switch (FOOT)       |
| 10. Fan control dial | 11. MODE switch (B/L) | 12. MODE switch (VENT)      |

# OPERATION

< SYSTEM DESCRIPTION >

[AUTOMATIC AIR CONDITIONING]

A/C switch	<p>Compressor control (switch indicator) changes between ON ↔ OFF each time when switch is pressed while air conditioning system is in the ON position.</p> <p><b>NOTE:</b> When either of following operation is performed while A/C switch indicator is OFF, compressor control change to ON but A/C switch indicator is not turned ON.</p> <ul style="list-style-type: none"> <li>• AUTO switch is turned ON.</li> <li>• Air outlet is set to D/F by MODE switch operation.</li> <li>• Air outlet is set to DEF by DEF switch operation.</li> <li>• Air inlet is changed to recirculation (REC) by intake switch operation.</li> </ul>
OFF switch	<p>Air conditioning system turns OFF and changes to the following status when switch is pressed while air conditioning system is in the ON position.</p> <ul style="list-style-type: none"> <li>• Air outlet: Foot</li> <li>• Air flow: OFF</li> <li>• Air inlet: Fresh air intake</li> <li>• A/C switch: OFF</li> </ul>
Temperature control dial	<p>Setting temperature can be set within a range of 18°C (60°F) – 32°C (90°F) at a rate of 0.5°C (1°F) per adjustment using this dial.</p> <ul style="list-style-type: none"> <li>• Clockwise rotation: Set temperature increases</li> <li>• Counterclockwise rotation: Set temperature decreases</li> </ul> <p><b>NOTE:</b> When air conditioning system is OFF position, setting temperature can be selected only while air conditioning system state (when MODE switch is pressed) is indicated on the display.</p>
AUTO switch	<p>“AUTO” is indicated on display and air conditioning system operates according to the following setting when switch is pressed.</p> <ul style="list-style-type: none"> <li>• Air outlet: Automatic control</li> <li>• Air flow: Automatic control</li> <li>• Air inlet: Automatic control</li> <li>• A/C switch*: ON</li> </ul> <p><b>NOTE:</b></p> <ul style="list-style-type: none"> <li>• When air outlet or air flow is manually operated while “AUTO” is indicated on display “AUTO” indication turns OFF. However, automatic control continues for other functions than air outlet or air flow.</li> <li>• *: A/C switch (compressor control) is turned ON when AUTO switch is turned ON while A/C switch indicator is OFF, but A/C switch indicator is not turned ON.</li> </ul>
MODE switch	<p>When each MODE switch is pressed, air outlet is switched and VENT, B/L, FOOT, or D/F<sup>1,2</sup> can be selected manually. (Switch indicator indicates air outlet status during automatic control.)</p> <p>*1: Air inlet is set to fresh air intake (FRE) and A/C switch turns ON, when D/F is selected while air conditioning system is in the ON position.</p> <p>*2: A/C switch (compressor control) is turned ON when D/F is selected while A/C switch indicator is OFF, but A/C switch indicator is not turned ON.</p> <p><b>NOTE:</b></p> <ul style="list-style-type: none"> <li>• Air outlet can be changed when air conditioning system is in the OFF position.</li> <li>• Air outlet automatic control is released (“AUTO” turns OFF) when each MODE switch is pressed while “AUTO” is indicated on display.</li> </ul>



A  
B  
C  
D  
E  
F  
G  
H  
J  
K  
L  
M  
N  
O  
P

HAC

# OPERATION

< SYSTEM DESCRIPTION >

[AUTOMATIC AIR CONDITIONING]

DEF switch	<p>DEF mode turns ON ⇔ OFF each time when switch is pressed.</p> <ul style="list-style-type: none"> <li>• When switch is pressed while air conditioning system is in the ON position.</li> <li>- Air conditioning system operates according to the following setting when DEF mode is turned ON.</li> <li>• Air outlet: DEF</li> <li>• Air flow: Previous setting before turning DEF mode ON</li> <li>• Air inlet: Fresh air intake</li> <li>• A/C switch*: ON</li> <li>- Air conditioning system operates according to the following setting when DEF mode is turned OFF.</li> <li>• Air outlet: Previous setting before turning DEF mode ON</li> <li>• Air flow: Previous setting before turning DEF mode OFF</li> <li>• Air inlet: Fresh air intake</li> <li>• A/C switch: Previous setting before turning DEF mode OFF</li> <li>• When switch is pressed while air conditioning system is in the OFF position.</li> <li>- Air conditioning system turns ON and operates according to the following setting when DEF mode is turned ON.</li> <li>• Air outlet: DEF</li> <li>• Air flow: Automatic control</li> <li>• Air inlet: Fresh air intake</li> <li>• A/C switch*: ON</li> <li>- Air conditioning system operates according to the following setting when DEF mode is turned OFF</li> <li>• Air outlet: Automatic control</li> <li>• Air flow: Previous setting before turning DEF mode OFF</li> <li>• Air inlet: Fresh air intake</li> <li>• A/C switch: Previous setting before turning DEF mode OFF</li> </ul> <p><b>NOTE:</b></p> <ul style="list-style-type: none"> <li>• When DEF mode is turned ON while "AUTO" is indicated on display, "AUTO" indication turns OFF. However, air flow automatic control continues.</li> <li>• *: A/C switch (compressor control) is turned ON when DEF switch is turned ON while A/C switch indicator is OFF, but A/C switch indicator is not turned ON.</li> </ul>
Intake switch	<ul style="list-style-type: none"> <li>• Air inlet changes between recirculation (REC) ⇔ fresh air intake (FRE) each time this switch is pressed.</li> <li>-  switch indicator ON: Recirculation*<sup>1, 2</sup></li> <li>-  switch indicator ON: Fresh air intake</li> <li>• Switch indicator blinks 2 times and air inlet is set to automatic control when switch is pressed and held for 2 seconds or more. (Switch indicator indicates air inlet status during automatic control.)</li> </ul> <p>*1: A/C switch turns ON when recirculation (REC) is selected while air conditioning system is in the ON position.</p> <p>*2: A/C switch (compressor control) is turned ON when recirculation (REC) is selected while A/C switch indicator is OFF, but A/C switch indicator is not turned ON.</p> <p><b>NOTE:</b></p> <ul style="list-style-type: none"> <li>• Air inlet can be changed when air conditioning system is in the OFF position.</li> <li>• Air inlet cannot be changed to recirculation (REC) when air outlet is in the D/F or DEF position.</li> <li>• Air inlet automatic control is released when A/C switch is in the OFF position.</li> </ul>
Fan control dial	<ul style="list-style-type: none"> <li>• Air flow can be manually set within a range of 1st – 7th speed using this dial.</li> <li>- Clockwise rotation: Air flow increases</li> <li>- Counterclockwise rotation: Air flow decreases</li> <li>• Air conditioning system turns ON and operates according to the following setting when this dial is turned one click to the left or right while air conditioning system is OFF.</li> <li>- Air outlet: Automatic control</li> <li>- Air flow: 1st speed</li> <li>- Air inlet: Automatic control</li> <li>- A/C switch: Previous setting before turning air conditioning system OFF</li> </ul> <p><b>NOTE:</b></p> <p>Air flow automatic control is released ("AUTO" turns OFF) when this dial is operated while "AUTO" is indicated on display.</p>

- In D-MODE: The following switches and dial cannot be operated.
- A/C switch
- OFF switch
- MODE switch
- Fan control dial

# DIAGNOSIS SYSTEM (A/C AUTO AMP.)

< SYSTEM DESCRIPTION >

[AUTOMATIC AIR CONDITIONING]

## DIAGNOSIS SYSTEM (A/C AUTO AMP.)

### Description

INFOID:000000009754325

Air conditioning system performs self-diagnosis, operation check, function diagnosis, and various settings using diagnosis function of each control unit.

ECU	Diagnostic item (CONSULT)	
A/C auto amp.	HVAC	Self Diagnostic Result
		Data Monitor
		Active Test
		Work support
Multi display unit	MDU	Self Diagnostic Result
		Data Monitor
		Active Test
BCM	BCM-AIR CONDITIONER	Self Diagnostic Result
		Data Monitor
ECM	ENGINE	Self Diagnostic Result
		Data Monitor
IPDM E/R	IPDM E/R	Self Diagnostic Result
		Data Monitor
		Auto active test

### CONSULT Function

INFOID:000000009754326

CONSULT performs the following functions via CAN communication with A/C auto amp.

Diagnostic mode	Description
Ecu Identification	Displays the part number of A/C auto amp.
Self Diagnostic Result	Displays the diagnosis results judged by A/C auto amp.
Data Monitor	Displays the input/output signal of A/C auto amp.
Active Test	The signals used to activate each device are forcibly supplied from A/C auto amp.
Work support	Changes the setting for each setting function and performs automatic adjustment of components.

#### NOTE:

Diagnosis should be performed with engine running. Door motor operation speeds become slower and NO results may be returned even for normal operation if battery voltage drops below 12 V during self-diagnosis.

#### ECU IDENTIFICATION

Part number of A/C auto amp. can be checked.

#### SELF-DIAGNOSIS RESULTS

Diagnosis result that is judged by A/C auto amp. can be checked. Refer to [HAC-32, "DTC Index"](#).

#### DATA MONITOR

Input/output signal of A/C auto amp. can be checked.

#### NOTE:

The following table includes information (items) inapplicable to this vehicle. For information (items) applicable to this vehicle, refer to CONSULT display items.

## DIAGNOSIS SYSTEM (A/C AUTO AMP.)

**[AUTOMATIC AIR CONDITIONING]**

< SYSTEM DESCRIPTION >

Display item list

Monitor item [Unit]	Description
AMB TEMP SEN                    [°C (°F)]	Ambient temperature value converted from ambient sensor signal received from ambient sensor
IN-VEH TEMP                    [°C (°F)]	In-vehicle temperature value converted from in-vehicle sensor signal received from in-vehicle sensor
INT TEMP SEN                    [°C (°F)]	Evaporator fin temperature value converted from intake sensor signal received from intake sensor
SUNLOAD SEN                    [w/m <sup>2</sup> ]	Sunload value converted from sunload sensor signal received from sunload sensor
AMB SEN CAL                    [°C (°F)]	Ambient temperature value calculated by A/C auto amp.
IN-VEH CAL                    [°C (°F)]	In-vehicle temperature value calculated by A/C auto amp.
INT TEMP CAL                    [°C (°F)]	Evaporator fin temperature value calculated by A/C auto amp.
SUNL SEN CAL                    [w/m <sup>2</sup> ]	Sunload value calculated by A/C auto amp.
COMP REQ SIG                    [On/Off]	Displays A/C ON signal ON/OFF status transmitted to BCM.
FAN REQ SIG                    [On/Off]	Displays blower fan ON signal ON/OFF status transmitted to BCM.
FAN DUTY*	Target value of voltage (applied voltage) applied to blower motor by A/C auto amp.
XM	Target discharge air temperature judged by A/C auto amp. depending on the temperature setting and the value from each sensor
ENG COOL TEMP                    [°C (°F)]	Engine coolant temperature signal value received from ECM via CAN communication

\*: "DUTY" is displayed, but voltage is indicated. Or unit is not displayed but unit is (V).

### ACTIVE TEST

The signals used to activate each device forcibly supplied from A/C auto amp. operation check of air conditioning system can be performed.

Test item	Description
HVAC TEST	The operation check of air conditioning system can be performed by selecting the mode. Refer to the following table for the conditions of each mode.

Check each output device

	Test item						
	MODE 1	MODE 2	MODE 3	MODE 4	MODE 5	MODE 6	MODE 7
Mode door motor position	VENT	VENT	B/L	B/L	FOOT*	D/F	DEF
Intake door motor position	REC	REC	REC	20% FRE	80% FRE	FRE	FRE
Air mix door motor position	FULL COLD	FULL COLD	FULL COLD	MIDDLE	MIDDLE	FULL HOT	FULL HOT
Blower motor (Applied voltage)	5 V	8.5 V	10.5 V	8.5 V	8.5 V	8.5 V	13 V
Magnet clutch	ON	ON	ON	ON	OFF	OFF	ON
Blower motor (Blower fan ON signal transmitted to BCM)	ON	ON	ON	ON	OFF	OFF	ON

\*: Position of mode door motor is set to the status of automatic control that is selected by foot position setting trimmer. Refer to [HAC-48, "Foot Position Setting Trimmer"](#).

### NOTE:

Perform the inspection of each output device after starting the engine because the compressor is operated.

### WORK SUPPORT

Setting change of each setting functions and automatic adjustment of components can be performed.



# DIAGNOSIS SYSTEM (A/C AUTO AMP.)

< SYSTEM DESCRIPTION >

[AUTOMATIC AIR CONDITIONING]

Work item	Description	Refer to	A
TEMP SET CORRECT	Setting change of temperature setting trimmer can be performed.	<a href="#">HAC-47, "Temperature Setting Trimmer"</a>	A
REC MEMORY SET	Setting change of inlet port memory function (REC) can be performed.	<a href="#">HAC-47, "Inlet Port Memory Function (REC)"</a>	B
FRE MEMORY SET	Setting change of inlet port memory function (FRE) can be performed.	<a href="#">HAC-48, "Inlet Port Memory Function (FRE)"</a>	C
BLOWER SET	Setting change of foot position setting trimmer can be performed.	<a href="#">HAC-48, "Foot Position Setting Trimmer"</a>	D
Door Motor Starting Position Reset	Starting position reset of air mix door motor and mode door motor can be performed.	<a href="#">HAC-49, "Work Procedure"</a>	D

**NOTE:**

When the battery cable is disconnected from the negative terminal or when the battery voltage becomes 10 V or less, the setting of WORK SUPPORT may be cancelled.

A  
B  
C  
D  
E  
F  
G  
H  
J  
K  
L  
M  
N  
O  
P

HAC

# DIAGNOSIS SYSTEM (BCM)

< SYSTEM DESCRIPTION >

[AUTOMATIC AIR CONDITIONING]

## DIAGNOSIS SYSTEM (BCM)

### COMMON ITEM

#### COMMON ITEM : CONSULT Function (BCM - COMMON ITEM)

INFOID:000000009754327

#### APPLICATION ITEM

CONSULT performs the following functions via CAN communication with BCM.

Diagnosis mode	Function Description
Work Support	Changes the setting for each system function.
Self Diagnostic Result	Displays the diagnosis results judged by BCM.
CAN Diag Support Monitor	Monitors the reception status of CAN communication viewed from BCM.
Data Monitor	The BCM input/output signals are displayed.
Active Test	The signals used to activate each device are forcibly supplied from BCM.
Ecu Identification	The BCM part number is displayed.
Configuration	<ul style="list-style-type: none"> <li>Read and save the vehicle specification.</li> <li>Write the vehicle specification when replacing BCM.</li> </ul>

#### SYSTEM APPLICATION

BCM can perform the following functions for each system.

#### NOTE:

It can perform the diagnosis modes except the following for all sub system selection items.

×: Applicable item

System	Sub system selection item	Diagnosis mode		
		Work Support	Data Monitor	Active Test
Door lock	DOOR LOCK	×	×	×
Rear window defogger	REAR DEFOGGER		×	×
Warning chime	BUZZER		×	×
Interior room lamp timer	INT LAMP	×	×	×
Exterior lamp	HEAD LAMP	×	×	×
Wiper and washer	WIPER	×	×	×
Turn signal and hazard warning lamps	FLASHER	×	×	×
Air conditioning system	AIR CONDITONER		×	×*
<ul style="list-style-type: none"> <li>Intelligent Key system</li> <li>Engine start system</li> </ul>	INTELLIGENT KEY	×	×	×
Combination switch	COMB SW		×	
Body control system	BCM	×		
NVIS - NATS	IMMU	×	×	×
Interior room lamp battery saver	BATTERY SAVER	×	×	×
Back door open	TRUNK		×	
Theft warning alarm	THEFT ALM	×	×	×
RAP	RETAINED PWR		×	
Signal buffer system	SIGNAL BUFFER		×	×
TPMS	AIR PRESSURE MONITOR	×	×	×

#### NOTE:

\*: For models with automatic A/C, this diagnosis mode is not used.

#### FREEZE FRAME DATA (FFD)

The BCM records the following vehicle condition at the time a particular DTC is detected, and displays on CONSULT.

# DIAGNOSIS SYSTEM (BCM)

[AUTOMATIC AIR CONDITIONING]

< SYSTEM DESCRIPTION >

CONSULT screen item	Indication/Unit	Description	
Vehicle Speed	km/h	Vehicle speed of the moment a particular DTC is detected	
Odo/Trip Meter	km	Total mileage (Odometer value) of the moment a particular DTC is detected	
Vehicle Condition	SLEEP>LOCK	Power position status of the moment a particular DTC is detected	While turning BCM status from low power consumption mode to normal mode (Power position is "LOCK".)
	SLEEP>OFF		While turning BCM status from low power consumption mode to normal mode (Power position is "OFF".)
	LOCK>ACC		While turning power position from "LOCK"* to "ACC"
	ACC>ON		While turning power position from "ACC" to "IGN"
	RUN>ACC		While turning power position from "RUN" to "ACC" (Vehicle is stopping and selector lever is except P position.)
	CRANK>RUN		While turning power position from "CRANKING" to "RUN" (From cranking up the engine to run it)
	RUN>URGENT		While turning power position from "RUN" to "ACC" (Emergency stop operation)
	ACC>OFF		While turning power position from "ACC" to "OFF"
	OFF>LOCK		While turning power position from "OFF" to "LOCK"*
	OFF>ACC		While turning power position from "OFF" to "ACC"
	ON>CRANK		While turning power position from "IGN" to "CRANKING"
	OFF>SLEEP		While turning BCM status from normal mode (Power position is "OFF".) to low power consumption mode
	LOCK>SLEEP		While turning BCM status from normal mode (Power position is "LOCK".) to low power consumption mode
	LOCK		Power position is "LOCK"*
	OFF		Power position is "OFF" (Ignition switch OFF)
	ACC		Power position is "ACC" (Ignition switch ACC)
	ON		Power position is "IGN" (Ignition switch ON with engine stopped)
ENGINE RUN	Power position is "RUN" (Ignition switch ON with engine running)		
CRANKING	Power position is "CRANKING" (At engine cranking)		
IGN Counter	0 - 39	The number of times that ignition switch is turned ON after DTC is detected <ul style="list-style-type: none"> <li>• The number is 0 when a malfunction is detected now.</li> <li>• The number increases like 1 → 2 → 3...38 → 39 after returning to the normal condition whenever ignition switch OFF → ON.</li> <li>• The number is fixed to 39 until the self-diagnosis results are erased if it is over 39.</li> </ul>	

**NOTE:**

\*: Power position shifts to "LOCK" from "OFF", when ignition switch is in the OFF position, selector lever is in the P position (A/T models and CVT models), and any of the following conditions are met.

- Closing door
- Opening door
- Door is locked using door request switch
- Door is locked using Intelligent Key

The power position shifts to "ACC" when the push-button ignition switch (push switch) is pushed at "LOCK".

## AIR CONDITIONER

### AIR CONDITIONER : CONSULT Function (BCM - AIR CONDITIONER) (Automatic A/C)

INFOID:000000009754328

#### DATA MONITOR

Display Item List

**NOTE:**

## DIAGNOSIS SYSTEM (BCM)

< SYSTEM DESCRIPTION >

[AUTOMATIC AIR CONDITIONING]

The following table includes information (items) inapplicable to this vehicle. For information (items) applicable to this vehicle, refer to CONSULT display items.

Monitor Item [Unit]	Contents
FAN ON SIG [On/Off]	Displays the blower fan status as judged from the A/C auto amp.
AIR COND SW [On/Off]	Displays [COMP (On)/COMP (Off)] status as judged from the A/C auto amp.

# A/C AUTO AMP.

< ECU DIAGNOSIS INFORMATION >

[AUTOMATIC AIR CONDITIONING]

## ECU DIAGNOSIS INFORMATION

### A/C AUTO AMP.

#### Reference Value

INFOID:000000009754329

#### CONSULT DATA MONITOR REFERENCE VALUES

**NOTE:**

The following table includes information (items) inapplicable to this vehicle. For information (items) applicable to this vehicle, refer to CONSULT display items.

Monitor item	Condition		Value/Status
AMB TEMP SEN	Ignition switch ON		Equivalent to ambient temperature
IN-VEH TEMP	Ignition switch ON		Equivalent to in-vehicle temperature
INT TEMP SEN	Ignition switch ON		Equivalent to evaporator fin temperature
SUNLOAD SEN	Ignition switch ON		Equivalent to sunload amount
AMB SEN CAL	Ignition switch ON		Equivalent to ambient temperature
IN-VEH CAL	Ignition switch ON		Equivalent to in-vehicle temperature
INT TEMP CAL	Ignition switch ON		Equivalent to evaporator fin temperature
SUNL SEN CAL	Ignition switch ON		Equivalent to sunload amount
COMP REQ SIG	Engine: Run at idle after warming up	A/C switch: ON (Compressor operation status)	On
		A/C switch: OFF	Off
FAN REQ SIG	Engine: Run at idle after warming up	Blower motor: ON	On
		Blower motor: OFF	Off
FAN DUTY*	Engine: Run at idle after warming up	Blower motor: ON	4 – 13
		Blower motor: OFF	0
XM	Ignition switch ON		Value according to target air flow temperature
ENG COOL TEMP	Ignition switch ON		Equivalent to engine coolant temperature

\*: "DUTY" is displayed, but voltage is indicated. Or unit is not displayed but unit is (V).

#### TERMINAL LAYOUT

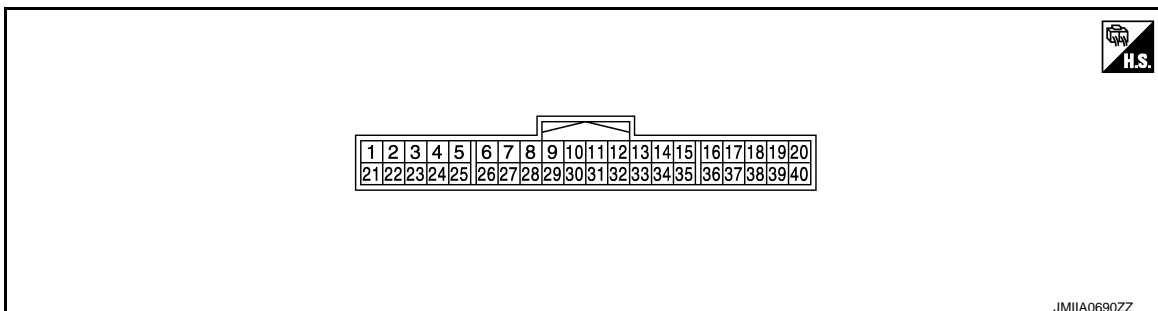

#### PHYSICAL VALUES

# A/C AUTO AMP.

< ECU DIAGNOSIS INFORMATION >

[AUTOMATIC AIR CONDITIONING]

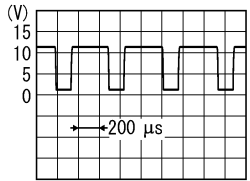
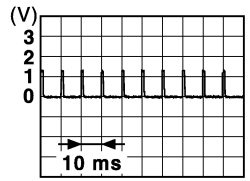
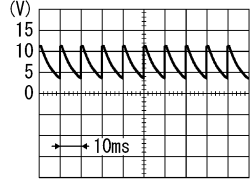
Terminal No. (Wire color)		Description		Condition	Value
+	-	Signal name	Input/ Output		
2 (LG)	30 (B)	In-vehicle sensor signal	Input	Ignition switch ON	0 – 4.8 V Output voltage varies with in-vehicle temperature
3 (V)	30 (B)	Intake sensor signal	Input	Ignition switch ON	0 – 4.8 V Output voltage varies with evaporator fin temperature
4 (GR)	30 (B)	Ambient sensor signal	Input	Ignition switch ON	0 – 4.8 V Output voltage varies with ambient temperature
5 (P)	30 (B)	Sunload sensor signal	Input	Ignition switch ON	0 – 4.8 V Output voltage varies with sunload amount
6 (L)	—	CAN-H	Input/ Output	—	—
7 (P)	—	CAN-L	Input/ Output	—	—
8 (W)	30 (B)	Intake door motor PBR power supply	Output	Ignition switch ON	4.8 – 5.2 V
9 (P)	30 (B)	A/C auto amp. connection recognition signal	Output	Ignition switch ON	11 – 14 V
10 (R)	30 (B)	Sensor ground	—	Ignition switch ON	0 – 0.1 V
11 (SB)	30 (B)	Ignition power supply	Input	Ignition switch ON	11 – 14 V
12 (Y)	30 (B)	Battery power supply	Input	Ignition switch OFF	11 – 14 V
13 (GR)	30 (B)	Power transistor control signal	Output	<ul style="list-style-type: none"> <li>Ignition switch ON</li> <li>Blower motor: 1st speed (manual)</li> </ul>	 <p style="text-align: right; font-size: small;">ZJIA0863J</p>
14 (LG)	30 (B)	Blower fan ON signal	Output	<ul style="list-style-type: none"> <li>Ignition switch ON</li> <li>Blower motor: OFF</li> </ul>	 <p style="text-align: right; font-size: small;">JMIA0941GB</p>
				<ul style="list-style-type: none"> <li>Ignition switch ON</li> <li>Blower motor: ON</li> </ul>	 <p style="text-align: right; font-size: small;">PKIB4960J</p>

# A/C AUTO AMP.

< ECU DIAGNOSIS INFORMATION >

[AUTOMATIC AIR CONDITIONING]

Terminal No. (Wire color)		Description		Condition	Value	
+	-	Signal name	Input/ Output			
15 (Y)	30 (B)	A/C ON signal	Output	<ul style="list-style-type: none"> <li>Ignition switch ON</li> <li>A/C switch: OFF (A/C indicator: OFF)</li> </ul>	<p>JPPIA0012GB</p>	
				<ul style="list-style-type: none"> <li>Ignition switch ON</li> <li>A/C switch: ON (A/C indicator: ON)</li> </ul>	<p>JMIIA0941GB</p>	
17 (BR)	30 (B)	A/MIX drive 4	Air mix door motor drive signal	Output	<ul style="list-style-type: none"> <li>Ignition switch ON</li> <li>Right after the temperature control dial operation</li> </ul>	<p>JPIIA1647GB</p>
18 (GR)	30 (B)	A/MIX drive 3				
19 (W)	30 (B)	A/MIX drive 2				
20 (L)	30 (B)	A/MIX drive 1				
21 (G)	30 (B)	Ignition power supply	Input	Ignition switch ON	11 – 14 V	
22 (SB)	30 (B)	Intake door motor PBR feedback signal	Input	<ul style="list-style-type: none"> <li>Ignition switch ON</li> <li>Intake switch: REC</li> </ul>	0.2 – 0.8 V	
				<ul style="list-style-type: none"> <li>Ignition switch ON</li> <li>Intake switch: FRE</li> </ul>	4.2 – 4.8 V	
30 (B)	Ground	Ground	—	Ignition switch ON	0 – 0.1 V	
35 (G)	30 (B)	REC	Intake door motor drive signal	Output	<ul style="list-style-type: none"> <li>Ignition switch ON</li> <li>Intake switch: FRE → REC</li> </ul>	9.5 – 13.5 V
				Output	<ul style="list-style-type: none"> <li>Ignition switch ON</li> <li>Intake switch: REC → FRE</li> </ul>	0 – 1 V
36 (V)	30 (B)	FRE		Output	<ul style="list-style-type: none"> <li>Ignition switch ON</li> <li>Intake switch: REC → FRE</li> </ul>	9.5 – 13.5 V
				Output	<ul style="list-style-type: none"> <li>Ignition switch ON</li> <li>Intake switch: FRE → REC</li> </ul>	0 – 1 V
37 (R)	30 (B)	MODE drive 4	Mode door motor drive signal	Output	<ul style="list-style-type: none"> <li>Ignition switch ON</li> <li>Right after the MODE switch operation</li> </ul>	<p>JPIIA1647GB</p>
38 (P)	30 (B)	MODE drive 3				
39 (Y)	30 (B)	MODE drive 2				
40 (V)	30 (B)	MODE drive 1				

A  
B  
C  
D  
E  
F  
G  
H  
I  
J  
K  
L  
M  
N  
O  
P

HAC

# A/C AUTO AMP.

< ECU DIAGNOSIS INFORMATION >

[AUTOMATIC AIR CONDITIONING]

## Fail-safe

INFOID:000000009754330

### FAIL-SAFE FUNCTION

If a communication error exists between the A/C auto amp. and multi display unit for 2 seconds or longer, air conditioning is controlled under the following conditions:

<b>A/C display</b>	<b>: OFF</b>
<b>Set temperature</b>	<b>: Setting before communication error occurs</b>
<b>Air outlet</b>	<b>: Automatic control</b>
<b>Air flow</b>	<b>: Automatic control</b>
<b>Air inlet</b>	<b>: Fresh air intake (FRE)</b>
<b>A/C switch</b>	<b>: ON</b>

## DTC Index

INFOID:000000009754331

DTC	Items (CONSULT screen terms)	Reference
U1000	CAN COMM CIRCUIT	<a href="#">HAC-50, "DTC Logic"</a>
U1010	CONTROL UNIT (CAN)	<a href="#">HAC-51, "DTC Logic"</a>
B2578	IN-VEHICLE SENSOR	<a href="#">HAC-52, "DTC Logic"</a>
B2579	IN-VEHICLE SENSOR	<a href="#">HAC-52, "DTC Logic"</a>
B257B	AMBIENT SENOR	<a href="#">HAC-55, "DTC Logic"</a>
B257C	AMBIENT SENOR	<a href="#">HAC-55, "DTC Logic"</a>
B2581	INTAKE SENSOR	<a href="#">HAC-58, "DTC Logic"</a>
B2582	INTAKE SENSOR	<a href="#">HAC-58, "DTC Logic"</a>
B2630*	SUNLOAD SENSOR	<a href="#">HAC-61, "DTC Logic"</a>
B2631*	SUNLOAD SENSOR	<a href="#">HAC-61, "DTC Logic"</a>
B27A0	INTAKE DOOR MOTOR	<a href="#">HAC-64, "DTC Logic"</a>
B27A1	INTAKE DOOR MOTOR	<a href="#">HAC-64, "DTC Logic"</a>
B27A2	DR AIR MIX DOOR MOT	<a href="#">HAC-68, "DTC Logic"</a>
B27A3	DR AIR MIX DOOR MOT	<a href="#">HAC-68, "DTC Logic"</a>
B27A4	DR AIR MIX DOOR MOT	<a href="#">HAC-68, "DTC Logic"</a>
B27A5	DR AIR MIX DOOR MOT	<a href="#">HAC-68, "DTC Logic"</a>
B27A6	MODE DOOR MOTOR	<a href="#">HAC-70, "DTC Logic"</a>
B27A7	MODE DOOR MOTOR	<a href="#">HAC-70, "DTC Logic"</a>
B27A8	MODE DOOR MOTOR	<a href="#">HAC-70, "DTC Logic"</a>
B27A9	MODE DOOR MOTOR	<a href="#">HAC-70, "DTC Logic"</a>

\*: Perform self-diagnosis under sunshine. When performing indoors, aim a light (more than 60 W) at sunload sensor, otherwise self-diagnosis indicates even though the sunload sensor is functioning normally.



# MULTI DISPLAY UNIT, BCM, ECM, IPDM E/R

< ECU DIAGNOSIS INFORMATION >

[AUTOMATIC AIR CONDITIONING]

## MULTI DISPLAY UNIT, BCM, ECM, IPDM E/R

### List of ECU Reference

INFOID:000000009754332

ECU	Reference
Multi display unit	<a href="#">AV-165, "Reference Value"</a>
	<a href="#">AV-167, "DTC Inspection Priority Chart"</a>
	<a href="#">AV-168, "DTC Index"</a>
BCM	<a href="#">BCS-36, "Reference Value"</a>
	<a href="#">BCS-57, "Fail-safe"</a>
	<a href="#">BCS-58, "DTC Inspection Priority Chart"</a>
ECM	<a href="#">BCS-59, "DTC Index"</a>
	<a href="#">EC-82, "Reference Value"</a>
	<a href="#">EC-97, "Fail Safe"</a>
	<a href="#">EC-99, "DTC Inspection Priority Chart"</a>
IPDM E/R	<a href="#">EC-101, "DTC Index"</a>
	<a href="#">PCS-17, "Reference Value"</a>
	<a href="#">PCS-23, "Fail-safe"</a>
<a href="#">PCS-24, "DTC Index"</a>	

A

B

C

D

E

F

G

H

**HAC**

J

K

L

M

N

O

P

# AUTOMATIC AIR CONDITIONING SYSTEM

[AUTOMATIC AIR CONDITIONING]

< WIRING DIAGRAM >

## WIRING DIAGRAM

### AUTOMATIC AIR CONDITIONING SYSTEM

#### Wiring Diagram

INFOID:000000009754333

#### AUTOMATIC AIR CONDITIONING SYSTEM

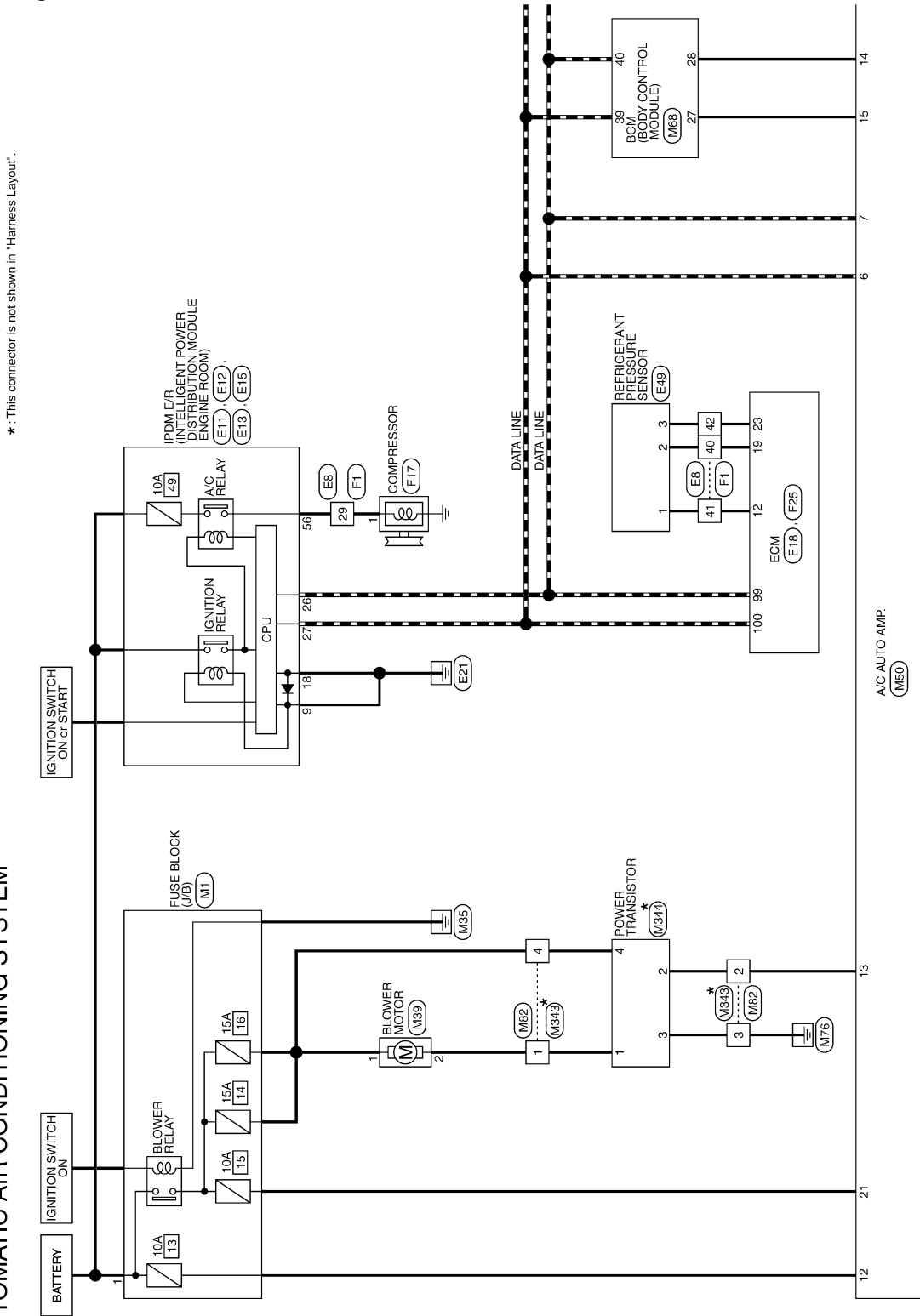

JRIWC0198GB

2011/08/18

# AUTOMATIC AIR CONDITIONING SYSTEM

< WIRING DIAGRAM >

[AUTOMATIC AIR CONDITIONING]

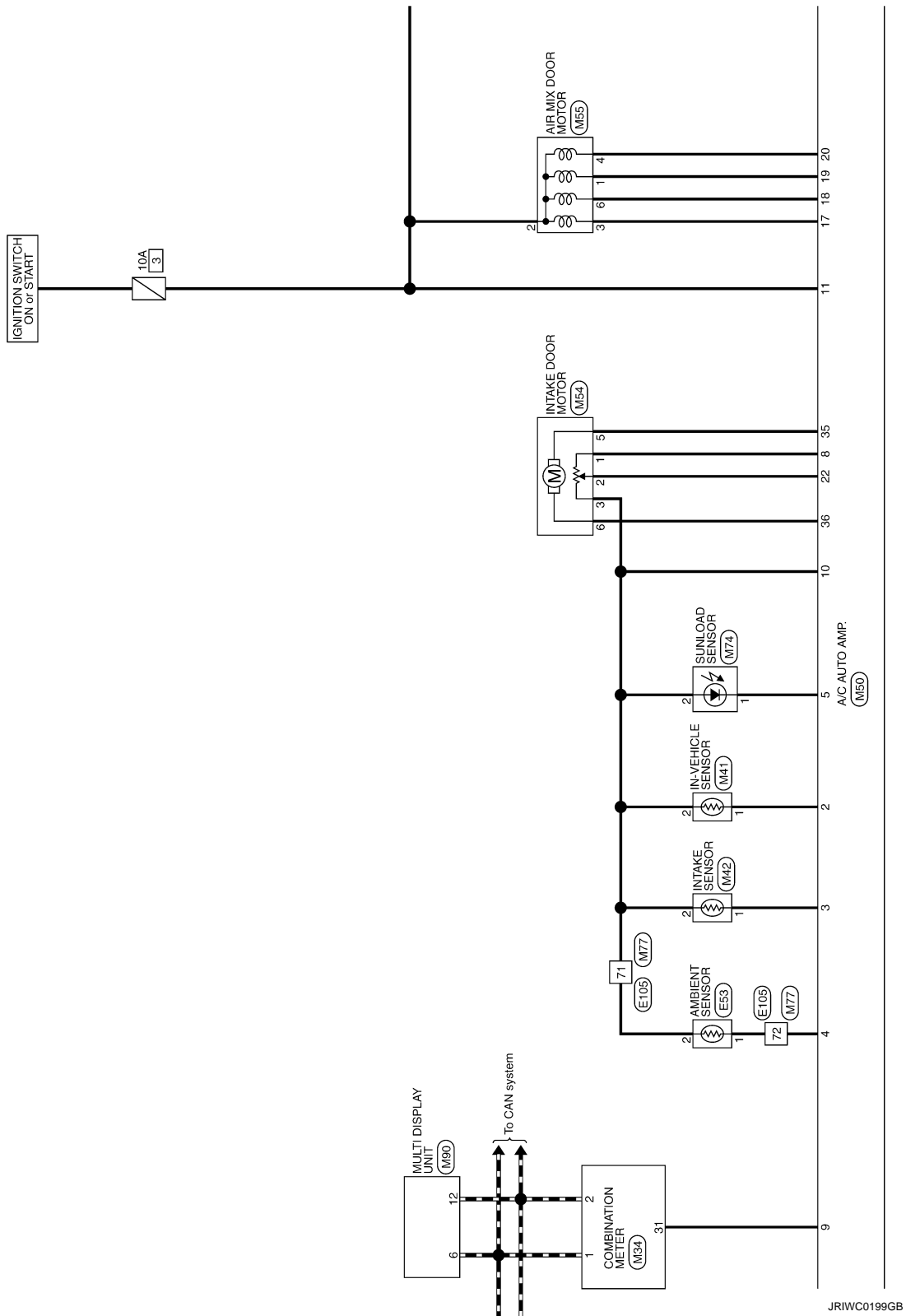

A  
B  
C  
D  
E  
F  
G  
H  
IAC  
J  
K  
L  
M  
N  
O  
P

JRIWC0199GB

# AUTOMATIC AIR CONDITIONING SYSTEM

< WIRING DIAGRAM >

[AUTOMATIC AIR CONDITIONING]

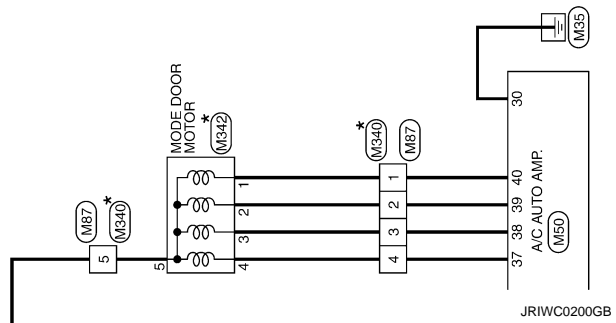

# AUTOMATIC AIR CONDITIONING SYSTEM

## [AUTOMATIC AIR CONDITIONING]

< WIRING DIAGRAM >

### AUTOMATIC AIR CONDITIONING SYSTEM

Connector No.	E8
Connector Name	WIRE TO WIRE
Connector Type	SAAS3MB-FS10-SLZZ

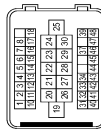

Terminal No.	Color	Wire	Signal Name [Specification]
1	P	-	-
2	L	-	-
3	G	-	-
4	LG	-	-
5	O	-	-
6	V	-	-
7	BR	-	-
8	SB	-	-
10	R	-	-
11	O	-	-
12	G	-	-
13	O	-	-
14	Y	-	-
15	R	-	-
16	SB	-	-
17	GR	-	-
18	W	-	-
19	L/W	-	-
20	L/W	-	-
21	G	-	-
22	G	-	-
23	SHIELD	-	-
24	P	-	-
25	R	-	-
26	B	-	-
27	B	-	-
28	LG	-	-
29	SB	-	-
30	R	-	-
31	O	-	-
32	O	-	-
33	BR	-	-
34	W	-	-
37	L	-	-
39	B	-	-

Connector No.	E10
Connector Name	INTELLIGENT POWER DISTRIBUTION MODULE ENGINE ROOM
Connector Type	TH12PW-RH

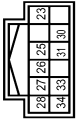

Terminal No.	Color	Wire	Signal Name [Specification]
23	SB	-	-
25	SB	-	-
26	SB	-	-
27	L	-	-
28	L	-	-
29	Y	-	-
30	Y	-	-
31	Y	-	-
33	G	-	-
34	L	-	-

Connector No.	E11
Connector Name	INTELLIGENT POWER DISTRIBUTION MODULE ENGINE ROOM
Connector Type	MS8FB-LC



Terminal No.	Color	Wire	Signal Name [Specification]
9	B/Y	-	-
14	R	-	-

Connector No.	E12
Connector Name	INTELLIGENT POWER DISTRIBUTION MODULE ENGINE ROOM
Connector Type	NS38FBR-CS

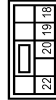

Terminal No.	Color	Wire	Signal Name [Specification]
18	B/Y	-	-
19	R	-	-
22	W	-	- [Without front fog lamp]
23	W	-	- [With front fog lamp]
20	G	-	- [Without front fog lamp]
20	V	-	- [With front fog lamp]
22	G	-	-

Connector No.	E13
Connector Name	INTELLIGENT POWER DISTRIBUTION MODULE ENGINE ROOM
Connector Type	TH12PW-RH



Terminal No.	Color	Wire	Signal Name [Specification]
23	SB	-	-
25	SB	-	-
26	SB	-	-
27	L	-	-
28	L	-	-
29	Y	-	-
30	Y	-	-
31	Y	-	-
33	G	-	-
34	L	-	-

Connector No.	E14
Connector Name	INTELLIGENT POWER DISTRIBUTION MODULE ENGINE ROOM
Connector Type	RS16FW-CS

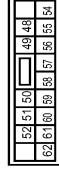

Terminal No.	Color	Wire	Signal Name [Specification]
48	BR	-	-
49	Y	-	-
50	G	-	-
51	L	-	-
52	B/Y	-	-
54	P	-	-
55	G	-	-
56	SB	-	-
57	O	-	-
58	LG	-	-

Connector No.	E15
Connector Name	INTELLIGENT POWER DISTRIBUTION MODULE ENGINE ROOM
Connector Type	TH12PW-RH



Terminal No.	Color	Wire	Signal Name [Specification]
99	P	-	-
100	L	-	-
101	V	-	-
102	R	-	-
103	BR	-	-
104	R	-	-
105	GR	-	-
106	Y	-	-
108	GR	-	-
109	O	-	-
110	O	-	-
111	B	-	-
112	BR	-	-
115	SB	-	-
116	G	-	-
117	Y	-	-
118	O	-	-
119	BR	-	-
120	Y	-	-
121	G	-	-
122	GR	-	-
123	B/Y	-	-
124	B/Y	-	-
125	W	-	-
126	W	-	-
127	B/Y	-	-

Connector No.	E16
Connector Name	INTELLIGENT POWER DISTRIBUTION MODULE ENGINE ROOM
Connector Type	TH12PW-RH



Terminal No.	Color	Wire	Signal Name [Specification]
99	P	-	-
100	L	-	-
101	V	-	-
102	R	-	-
103	BR	-	-
104	R	-	-
105	GR	-	-
106	Y	-	-
108	GR	-	-
109	O	-	-
110	O	-	-
111	B	-	-
112	BR	-	-
115	SB	-	-
116	G	-	-
117	Y	-	-
118	O	-	-
119	BR	-	-
120	Y	-	-
121	G	-	-
122	GR	-	-
123	B/Y	-	-
124	B/Y	-	-
125	W	-	-
126	W	-	-
127	B/Y	-	-

A  
B  
C  
D  
E  
F  
G  
H  
HAC  
J  
K  
L  
M  
N  
O  
P

# AUTOMATIC AIR CONDITIONING SYSTEM

< WIRING DIAGRAM >

[AUTOMATIC AIR CONDITIONING]

## AUTOMATIC AIR CONDITIONING SYSTEM

Connector No.	E49
Connector Name	REFRIGERANT PRESSURE SENSOR
Connector Type	RK02FB



Terminal No.	Color Of Wire	Signal Name [Specification]
1	V	
2	P	
3	L	

Connector No.	E53
Connector Name	AMBIENT SENSOR
Connector Type	RS02FB



Terminal No.	Color Of Wire	Signal Name [Specification]
1	V	AMBIENT SENSOR SIGNAL
2	LG	SENSOR GROUND

Connector No.	E105
Connector Name	WIRE TO WIRE
Connector Type	TH80MK-CS16-1M4

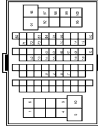

Terminal No.	Color Of Wire	Signal Name [Specification]
1	V	
2	Y	
3	GR	
4	P	
5	G	
6	O	
7	R	
8	LG	
9	GR	
10	O	
11	GR	
12	W	
13	SB	
14	BR	
15	LG	
16	V	
17	L	
18	R	
19	B	
20	W	
21	OG	
22	Y	
23	SHIELD	
24	R	
25	GR	
26	O	
27	SHIELD	
28	G	
29	R	

05	BR	
06	P	
07	GR	
08	W	
09	V	
100	O	

Connector No.	F1
Connector Name	WIRE TO WIRE
Connector Type	SXA3RFB-RS10-SJ22



Terminal No.	Color Of Wire	Signal Name [Specification]
1	P	
2	L	
3	Y	
4	EG	
5	LG	
6	SB	
7	O	
8	Y	
9	GR	
10	BR	
11	Y	
12	G	
13	EG	
14	L	
15	BR	
16	P	
17	SB	
18	G	
19	G	
20	BR	
21	OG	
22	SHIELD	
23	R	
24	R	
25	B	
26	B	
27	R	
28	R	
29	W	

30	R	
31	EG	
32	LG	
33	BR	
34	G	
37	G	
39	B	
40	P	
41	BR	
42	W	
43	L	
44	G	
45	BR	
46	R	
47	Y	
48	GR	

Connector No.	F17
Connector Name	COMPRESSOR
Connector Type	RS01FE



Terminal No.	Color Of Wire	Signal Name [Specification]
1	W	MAGNET CLUTCH POWER SUPPLY

Connector No.	F25
Connector Name	ECM
Connector Type	PH40FE-R28-L-1RH



JRIWC1720GB

# AUTOMATIC AIR CONDITIONING SYSTEM

< WIRING DIAGRAM >

[AUTOMATIC AIR CONDITIONING]

## AUTOMATIC AIR CONDITIONING SYSTEM

Terminal No.	Color Of Wire	Signal Name [Specification]
1	B	ECM GROUND (FUEL INJECTOR)
2	B	ECM GROUND (FUEL INJECTOR)
3	G	FUEL INJECTOR NO.1 (4 HD)
4	Y	FUEL INJECTOR NO.2 (3 HD)
5	R	FUEL INJECTOR NO.1 (LO)
6	BR	FUEL INJECTOR NO.2 (LO)
7	W	FUEL INJECTOR NO.3 (LO)
8	R	FUEL INJECTOR NO.4 (LO)
9	W	SENSOR GROUND
10	LG	SENSOR GROUND
11	P	SENSOR GROUND
12	BR	SENSOR GROUND
13	G	MASS AIR FLOW SENSOR
14	L	ENGINE OIL PRESSURE SENSOR
15	L	EVAP CONTROL SYSTEM PRESSURE SENSOR
17	Y	INTAKE AIR TEMPERATURE SENSOR
18	GR	FUEL RAIL PRESSURE SENSOR
19	P	REFRIGERANT PRESSURE SENSOR
21	W	A.F. SENSOR 1
22	Y	ENGINE OIL TEMPERATURE SENSOR
23	W	SENSOR POWER SUPPLY
25	B	A.F. SENSOR 1
29	W	HEATED OXYGEN SENSOR 2
33	R	SENSOR GROUND
35	SHIELD	SENSOR GROUND
36	W	KNOCK SENSOR
38	B	SHIELD
39	B	SENSOR POWER SUPPLY
41	W	TURBOCHARGER BOOST SENSOR
43	G	ENGINE OIL PRESSURE SENSOR
44	SB	SENSOR GROUND

Connector No.	M1
Connector Name	FUSE BLOCK (J/B)
Connector Type	LO1FW-MC



Terminal No.	Color Of Wire	Signal Name [Specification]
1	W	—

Connector No.	M34
Connector Name	COMBINATION METER
Connector Type	TH40FW-AH



Terminal No.	1	2	3	4	5	6	7	8	9	10	11	12	13	14	15	16	17	18	19	20	21	22	23	24	25	26	27	28	29	30	31	32	33	34	35	36	37	38	39	40	41	42	43	44	45	46	47	48	49	50
--------------	---	---	---	---	---	---	---	---	---	----	----	----	----	----	----	----	----	----	----	----	----	----	----	----	----	----	----	----	----	----	----	----	----	----	----	----	----	----	----	----	----	----	----	----	----	----	----	----	----	----

Terminal No.	Color Of Wire	Signal Name [Specification]
28	V	PADDLE SHIFTER DOWN SWITCH SIGNAL
29	LG	BATTERY SUPPLY
30	LG	BATTERY SUPPLY
31	LG	PASSENGER SIDE AIR BAG INFLATOR SIGNAL (With front fog lamp)
32	LG	PASSENGER SIDE AIR BAG INFLATOR SIGNAL (Without front fog lamp)
33	V	A.C. AUTO AMP. CONNECTION RECOGNITION SIGNAL
36	LG	MANUAL MODE SIGNAL (With front fog lamp)
38	Y	MANUAL MODE SIGNAL (Without front fog lamp)
37	G	NON-MANUAL MODE SIGNAL (Without front fog lamp)
37	Y	NON-MANUAL MODE SIGNAL (With front fog lamp)
38	P	ALTERNATOR SIGNAL

Connector No.	M39
Connector Name	BI LOWER MOTOR
Connector Type	TM02FW



Terminal No.	Color Of Wire	Signal Name [Specification]
1	Y	—
2	L	—

Connector No.	M41
Connector Name	IN-VEHICLE SENSOR
Connector Type	AD0FW



Terminal No.	Color Of Wire	Signal Name [Specification]
1	LG	IN-VEHICLE SENSOR SIGNAL
2	R	SENSOR GROUND

Connector No.	M42
Connector Name	INTAKE SENSOR
Connector Type	TK02FB



Terminal No.	Color Of Wire	Signal Name [Specification]
1	Y	INTAKE SENSOR SIGNAL
2	R	SENSOR GROUND

Connector No.	M50
Connector Name	A.C. AUTO AMP.
Connector Type	TH40FW-NH



Terminal No.	1	2	3	4	5	6	7	8	9	10	11	12	13	14	15	16	17	18	19	20	21	22	23	24	25	26	27	28	29	30	31	32	33	34	35	36	37	38	39	40	41	42	43	44	45	46	47	48	49	50
--------------	---	---	---	---	---	---	---	---	---	----	----	----	----	----	----	----	----	----	----	----	----	----	----	----	----	----	----	----	----	----	----	----	----	----	----	----	----	----	----	----	----	----	----	----	----	----	----	----	----	----

Terminal No.	Color Of Wire	Signal Name [Specification]
2	LG	IN-VEHICLE SENSOR SIGNAL
3	V	INTAKE SENSOR SIGNAL
4	GR	AMBIENT SENSOR SIGNAL
5	P	SUNLOAD SENSOR SIGNAL
6	L	CAN-H
7	P	CAN-L
8	W	INTAKE DOOR MOTOR PWR POWER SUPPLY
9	P	A.C. AUTO AMP. CONNECTION RECOGNITION SIGNAL
10	R	SENSOR GROUND
11	SB	BATTERY POWER SUPPLY
12	SB	BATTERY POWER SUPPLY
13	GR	POWER BLOWER CAN SIGNAL
14	LG	POWER BLOWER CAN SIGNAL
15	Y	A.C. ON SIGNAL
17	BR	A.MIX DRIVE SIGNAL 4
18	GR	A.MIX DRIVE SIGNAL 3
19	W	A.MIX DRIVE SIGNAL 2
20	L	A.MIX DRIVE SIGNAL 1

A  
B  
C  
D  
E  
F  
G  
H  
I  
J  
K  
L  
M  
N  
O  
P

HAC

# AUTOMATIC AIR CONDITIONING SYSTEM

## [AUTOMATIC AIR CONDITIONING]

< WIRING DIAGRAM >

### AUTOMATIC AIR CONDITIONING SYSTEM

27	IGNITION POWER SUPPLY
28	IGNITION MOTOR P/B F/B SIGNAL
29	INTAKE DOOR MOTOR P/B F/B SIGNAL
30	GROUND
35	REC DRIVE SIGNAL
36	FRE DRIVE SIGNAL
37	MODE DRIVE SIGNAL 4
38	MODE DRIVE SIGNAL 3
39	MODE DRIVE SIGNAL 2
40	MODE DRIVE SIGNAL 1

Connector No.	M54
Connector Name	INTAKE DOOR MOTOR
Connector Type	88193-9001



Terminal No.	Color Of Wire	Signal Name [Specification]
1	W	INTAKE DOOR MOTOR P/B POWER SUPPLY
2	SB	INTAKE DOOR MOTOR P/B F/B SIGNAL
3	R	GROUND
5	G	REC DRIVE SIGNAL
6	V	INTAKE DOOR MOTOR P/B F/B SIGNAL

Connector No.	M55
Connector Name	AIR MIX DOOR MOTOR
Connector Type	MAA08FB



Terminal No.	Color Of Wire	Signal Name [Specification]
1	W	A.MIX DRIVE SIGNAL 2
2	SB	IGNITION POWER SUPPLY
3	BR	A.MIX DRIVE SIGNAL 4
4	L	A.MIX DRIVE SIGNAL 1

### AUTOMATIC AIR CONDITIONING SYSTEM

38	P	COMBI SW OUTPUT 1
37	G	DETAIL SW
38	SB	RECEIVER COMM
39	L	CAN-H
40	P	CAN-L

Connector No.	M68
Connector Name	BCM (BODY CONTROL MODULE)
Connector Type	TH40FB-NH



Terminal No.	Color Of Wire	Signal Name [Specification]
2	L	COMBI SW INPUT 5
3	GR	COMBI SW INPUT 4
4	BR	COMBI SW INPUT 3
5	G	COMBI SW INPUT 2
6	W	COMBI SW INPUT 1
7	L	KEY CYL UNLOCK SW
8	R	STOP LAMP SW 1
9	R	STOP LAMP SW 1
10	W	STOP LAMP SW 1
12	GR	DOOR L.L. & UNLK SW LOCK (Without front fog lamp)
13	GR	DOOR L.L. & UNLK SW LOCK (With front fog lamp)
14	BR	DOOR L.L. UNLOCK
15	P	OPTICAL SENS
16	W	RS DEFROGGER SW
17	R	OPTICAL SENS PWR SPLY
18	V	RECEIVER GND
21	P	NATS ANT AMP
23	R	SECURITY IND LAMP CONT
24	SB	DONCLE LINK
25	LG	NATS ANT AMP
26	B	THERMO AMP
27	W	A/G SW (With front fog lamp)
27	Y	A/G SW (Without front fog lamp)
28	LG	BLOWER FAN SW (Without front fog lamp)
28	O	BLOWER FAN SW (With front fog lamp)
29	W	MAZDASW (With front fog lamp)
29	SB	MAZDASW (Without front fog lamp)
30	L	BR DOOR OPENER SW
31	GR	BR DOOR UNLK SENS
32	LG	COMBI SW OUTPUT 5
33	Y	COMBI SW OUTPUT 4
34	V	COMBI SW OUTPUT 3
35	R	COMBI SW OUTPUT 2

53	L	COMBI SW OUTPUT 1
54	SB	DETAIL SW
55	P	RECEIVER COMM
58	LG	CAN-H
59	G	CAN-L
64	G	RECEIVER COMM
65	GR	RECEIVER COMM
66	Y	RECEIVER COMM
67	V	RECEIVER COMM
68	R	RECEIVER COMM
70	V	RECEIVER COMM
71	R	RECEIVER COMM
72	GR	RECEIVER COMM
73	G	RECEIVER COMM
74	W	RECEIVER COMM
78	LG	RECEIVER COMM
79	V	RECEIVER COMM
80	LG	RECEIVER COMM
83	P	RECEIVER COMM
84	G	RECEIVER COMM
85	BR	RECEIVER COMM
86	LG	RECEIVER COMM
90	SHIELD	RECEIVER COMM
91	Y	RECEIVER COMM
92	BR	RECEIVER COMM
95	R	RECEIVER COMM
96	Y	RECEIVER COMM
96	L	RECEIVER COMM
98	GR	RECEIVER COMM
98	W	RECEIVER COMM
99	W	RECEIVER COMM
100	LG	RECEIVER COMM

Connector No.	M74
Connector Name	SUNLOAD SENSOR
Connector Type	A09FW



Terminal No.	Color Of Wire	Signal Name [Specification]
1	P	SUNLOAD SENSOR SIGNAL
2	R	SENSOR GROUND

Connector No.	M77
Connector Name	WIRE TO WIRE
Connector Type	TH88FW-ZS16-TM

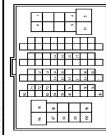

Terminal No.	Color Of Wire	Signal Name [Specification]
1	L	RECEIVER COMM
4	V	RECEIVER COMM
5	W	RECEIVER COMM
8	R	RECEIVER COMM
9	R	RECEIVER COMM
10	R	RECEIVER COMM
34	LG	RECEIVER COMM
35	SB	RECEIVER COMM
36	B	RECEIVER COMM
37	P	RECEIVER COMM
32	R	RECEIVER COMM

Connector No.	M82
Connector Name	WIRE TO WIRE
Connector Type	M04FW-LG



JRIWC1722GB



# AUTOMATIC AIR CONDITIONING SYSTEM

< WIRING DIAGRAM >

[AUTOMATIC AIR CONDITIONING]

## AUTOMATIC AIR CONDITIONING SYSTEM

Terminal No.	Color Of Wire	Signal Name [Specification]
1	-	-
2	GR	-
3	B	-
4	Y	-

Connector No.	M87
Connector Name	WIRE TO WIRE
Connector Type	TH08PW-NH



Terminal No.	Color Of Wire	Signal Name [Specification]
1	V	-
2	Y	-
3	P	-
4	R	-
5	SB	-

Connector No.	M89
Connector Name	MULTI DISPLAY UNIT
Connector Type	TH12PW-NH



Terminal No.	Color Of Wire	Signal Name [Specification]
2	V	BAT
3	V	BL3
5	GR	ILLCONT
6	L	CAN-H
7	SB	IGN
10	B	GND
11	B	GND

Terminal No.	12	P	CAN-L
--------------	----	---	-------

Connector No.	M240
Connector Name	WIRE TO WIRE
Connector Type	TH08MW



Terminal No.	Color Of Wire	Signal Name [Specification]
1	-	-
2	-	-
3	-	-
4	-	-
5	-	-

Connector No.	M242
Connector Name	MODE DOOR MOTOR
Connector Type	H8192-1001



Terminal No.	Color Of Wire	Signal Name [Specification]
1	-	MODE DRIVE SIGNAL 1
2	-	MODE DRIVE SIGNAL 2
3	-	MODE DRIVE SIGNAL 3
4	-	MODE DRIVE SIGNAL 4
5	-	IGNITION POWER SUPPLY

Connector No.	M243
Connector Name	WIRE TO WIRE
Connector Type	M02MW



Terminal No.	Color Of Wire	Signal Name [Specification]
1	R	-
2	B	-
3	-	-
4	Y	-

Connector No.	M244
Connector Name	POWER TRANSISTOR
Connector Type	TRW 8512100-F



Terminal No.	Color Of Wire	Signal Name [Specification]
1	R	BLOWER MOTOR CONTROL OUTPUT
2	G	POWER TRANSISTOR CONTROL SIGNAL
3	B	GROUND
4	Y	IGNITION POWER SUPPLY

JRIWC1723GB

A  
B  
C  
D  
E  
F  
G  
H  
HAC  
J  
K  
L  
M  
N  
O  
P

# DIAGNOSIS AND REPAIR WORK FLOW

< BASIC INSPECTION >

[AUTOMATIC AIR CONDITIONING]

## BASIC INSPECTION

### DIAGNOSIS AND REPAIR WORK FLOW

Work Flow

INFOID:000000009754334

OVERALL SEQUENCE

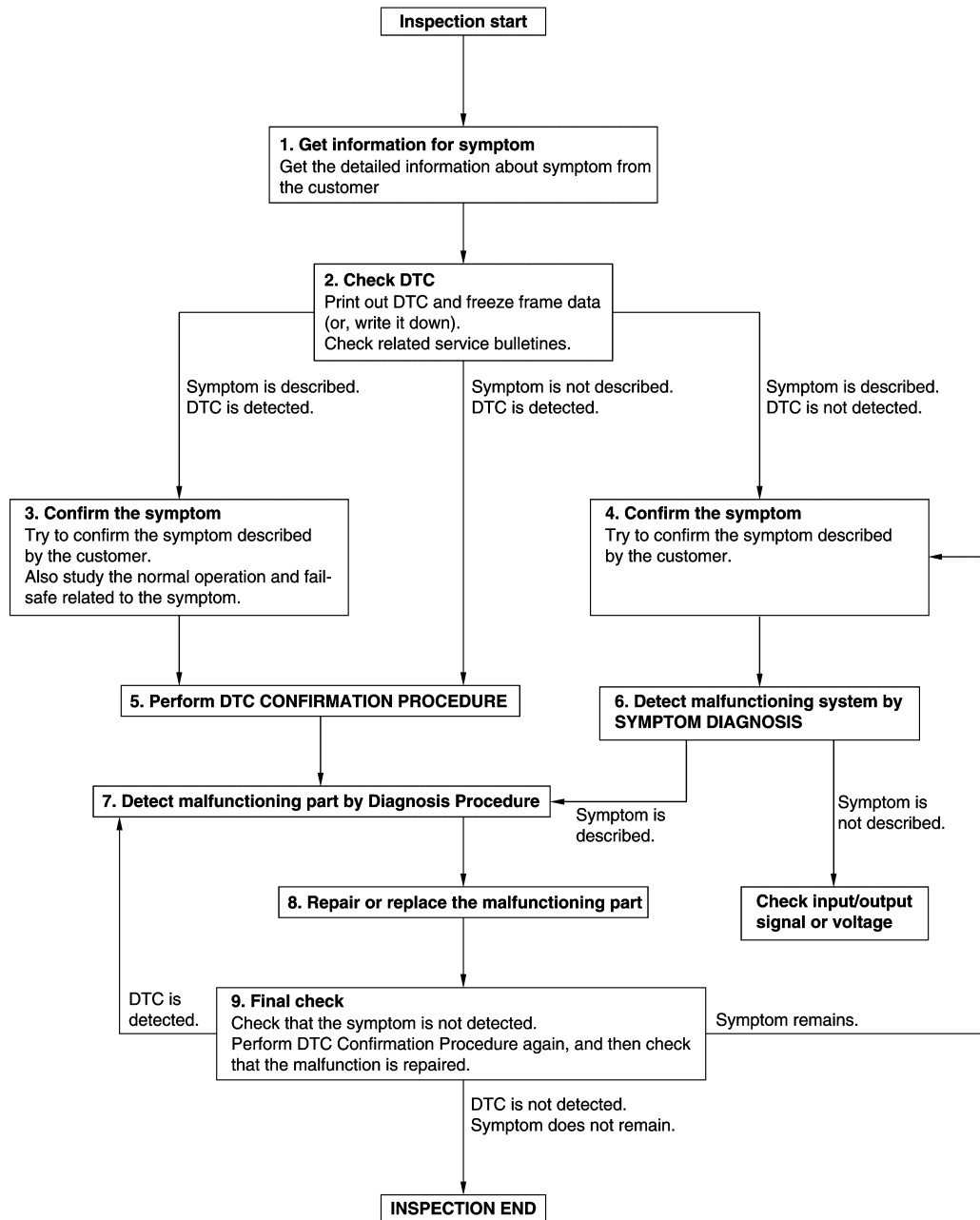

JMKIA8652GB

DETAILED FLOW

Revision: 2013 October

HAC-42

2014 JUKE

# DIAGNOSIS AND REPAIR WORK FLOW

< BASIC INSPECTION >

[AUTOMATIC AIR CONDITIONING]

## 1. GET INFORMATION FOR SYMPTOM

1. Get detailed information from the customer about the symptom (the condition and the environment when the incident/malfunction occurs).
2. Check operation condition of the function that is malfunctioning.

>> GO TO 2.

## 2. CHECK DTC

1. Check DTC.
2. Perform the following procedure if DTC is detected.
  - Record DTC and freeze frame data (Print them out using CONSULT.)
  - Erase DTC.
  - Study the relationship between the cause detected by DTC and the symptom described by the customer.
3. Check related service bulletins for information.

Are any symptoms described and any DTC detected?

Symptom is described, DTC is detected>>GO TO 3.

Symptom is described, DTC is not detected>>GO TO 4.

Symptom is not described, DTC is detected>>GO TO 5.

## 3. CONFIRM THE SYMPTOM

Try to confirm the symptom described by the customer.

Also study the normal operation and fail-safe related to the symptom.

Verify relation between the symptom and the condition when the symptom is detected.

>> GO TO 5.

## 4. CONFIRM THE SYMPTOM

Try to confirm the symptom described by the customer.

Verify relation between the symptom and the condition when the symptom is detected.

>> GO TO 6.

## 5. PERFORM DTC CONFIRMATION PROCEDURE

Perform DTC CONFIRMATION PROCEDURE for the detected DTC, and then check that DTC is detected again. At this time, always connect CONSULT to the vehicle, and check self diagnostic results in real time. If two or more DTCs are detected, refer to DTC INSPECTION PRIORITY CHART, and determine trouble diagnosis order.

### NOTE:

- Freeze frame data is useful if the DTC is not detected.
- Perform Component Function Check if DTC CONFIRMATION PROCEDURE is not included on Service Manual. This simplified check procedure is an effective alternative though DTC cannot be detected during this check.

If the result of Component Function Check is NG, it is the same as the detection of DTC by DTC CONFIRMATION PROCEDURE.

Is DTC detected?

YES >> GO TO 7.

NO >> Check according to [GI-46. "Intermittent Incident"](#).

## 6. DETECT MALFUNCTIONING SYSTEM BY SYMPTOM DIAGNOSIS

Detect malfunctioning system according to SYMPTOM DIAGNOSIS based on the confirmed symptom in step 4, and determine the trouble diagnosis order based on possible causes and symptom.

Is the symptom described?

YES >> GO TO 7.

NO >> Monitor input data from related sensors or check voltage of related module terminals using CONSULT.

## 7. DETECT MALFUNCTIONING PART BY DIAGNOSIS PROCEDURE

A  
B  
C  
D  
E  
F  
G  
H  
HAC  
J  
K  
L  
M  
N  
O  
P

## DIAGNOSIS AND REPAIR WORK FLOW

[AUTOMATIC AIR CONDITIONING]

< BASIC INSPECTION >

Inspect according to Diagnosis Procedure of the system.

Is malfunctioning part detected?

YES >> GO TO 8.

NO >> Check according to [GI-46. "Intermittent Incident"](#).

### 8. REPAIR OR REPLACE THE MALFUNCTIONING PART

---

1. Repair or replace the malfunctioning part.
2. Reconnect parts or connectors disconnected during Diagnosis Procedure again after repair and replacement.
3. Check DTC. If DTC is detected, erase it.

>> GO TO 9.

### 9. FINAL CHECK

---

When DTC is detected in step 2, perform DTC CONFIRMATION PROCEDURE again, and then check that the malfunction is repaired securely.

When symptom is described by the customer, refer to confirmed symptom in step 3 or 4, and check that the symptom is not detected.

Is DTC detected and does symptom remain?

YES-1 >> DTC is detected: GO TO 7.

YES-2 >> Symptom remains: GO TO 4.

NO >> Before returning the vehicle to the customer, always erase DTC.

# OPERATION INSPECTION

< BASIC INSPECTION >

[AUTOMATIC AIR CONDITIONING]

## OPERATION INSPECTION

### Work Procedure

INFOID:000000009754335

The purpose of the operational check is to check that the individual system operates normally.

**Check condition : Engine running at normal operating temperature.**

#### 1.CHECK MEMORY FUNCTION

1. Set temperature to 32°C (90°F) by operating the temperature control dial.
2. Press OFF switch.
3. Turn ignition switch OFF.
4. Turn ignition switch ON.
5. Press AUTO switch.
6. Check that set temperature is maintained.

Is the inspection result normal?

- YES >> GO TO 2.  
NO >> GO TO 10.

#### 2.CHECK AIR FLOW

1. Start engine.
2. Operate fan control dial.
3. Check that air flow changes. Check operation for all fan speeds.

Is the inspection result normal?

- YES >> GO TO 3.  
NO >> GO TO 10.



#### 3.CHECK AIR OUTLET

1. Operate fan control dial to set the fan speed to maximum speed.
2. Operate MODE switch and DEF switch.
3. Check that air outlets change according to each indicated air outlet by placing a hand in front of the air outlets. Refer to [VTL-5, "System Description"](#).

Is the inspection result normal?

- YES >> GO TO 4.  
NO >> GO TO 10.

#### 4.CHECK AIR INLET

1. Press intake switch to set the air inlet to recirculation. [Intake switch indicator (  side) turns ON.]
2. Listen to intake sound and confirm air inlets change.
3. Press intake switch again to set the air inlet to fresh air intake. [Intake switch indicator (  side) turns OFF and (  side) turns ON.]
4. Listen to intake sound and confirm air inlets change.

Is the inspection result normal?

- YES >> GO TO 5.  
NO >> GO TO 10.

#### 5.CHECK COMPRESSOR

1. Press A/C switch. The A/C switch indicator is turns ON.
2. Check visually and by sound that the compressor operates.
3. Press A/C switch again The A/C switch indicator is turns OFF.
4. Check that compressor stops.

Is the inspection result normal?

- YES >> GO TO 6.  
NO >> GO TO 10.

#### 6.CHECK DISCHARGE AIR TEMPERATURE

1. Operate temperature control dial.
2. Check that discharge air temperature changes.

A

B

C

D

E

F

G

H

HAC

J

K

L

M

N

O

P

# OPERATION INSPECTION

[AUTOMATIC AIR CONDITIONING]

< BASIC INSPECTION >

Is the inspection result normal?

- YES >> GO TO 7.
- NO >> GO TO 10.

## 7.CHECK TEMPERATURE DECREASE

---

1. Operate compressor.
2. Operate temperature control dial and lower the set temperature to 18°C (60°F).
3. Check that cool air blows from the air outlets.

Is the inspection result normal?

- YES >> GO TO 8.
- NO >> GO TO 10.

## 8.CHECK TEMPERATURE INCREASE

---

1. Operate temperature control dial and raise the set temperature to 32°C (90°F).
2. Check that warm air blows from the air outlets.

Is the inspection result normal?

- YES >> GO TO 9.
- NO >> GO TO 10.

## 9.CHECK AUTO MODE

---

1. Press AUTO switch to confirm that "AUTO" is indicated on the display.
2. Operate temperature control dial to check that air outlet or air flow changes (the air outlet or air flow varies depending on the ambient temperature, in-vehicle temperature, set temperature, and etc.).

Is the inspection result normal?

- YES >> INSPECTION END
- NO >> GO TO 10.

## 10.CHECK SELF-DIAGNOSIS WITH CONSULT

---

1. Perform self-diagnosis with CONSULT.
2. Check that any DTC is detected.

Is any DTC detected?

- YES >> Refer to [HAC-32. "DTC Index"](#) and perform the appropriate diagnosis.
- NO >> GO TO 11.

## 11.CHECK FAIL-SAFE ACTIVATION

---

Check that symptom is applied to the fail-safe activation. Refer to [HAC-32. "Fail-safe"](#).

>> Refer to [HAC-83. "Symptom Table"](#) and perform the appropriate diagnosis.

# SYSTEM SETTING

< BASIC INSPECTION >

[AUTOMATIC AIR CONDITIONING]

## SYSTEM SETTING

### Temperature Setting Trimmer

INFOID:000000009754336

#### DESCRIPTION

If the temperature felt by the customer is different from the air flow temperature controlled by the temperature setting, the A/C auto amp. control temperature can be adjusted to compensate for the temperature setting.

#### HOW TO SET

Ⓜ With CONSULT

Perform "TEMP SET CORRECT" of HVAC work support item.

Work support items	Display (°C)	Display (°F)
TEMP SET CORRECT	3.0	6
	2.5	5
	2.0	4
	1.5	3
	1.0	2
	0.5	1
	0 (initial status)	0 (initial status)
	-0.5	-1
	-1.0	-2
	-1.5	-3
	-2.0	-4
	-2.5	-5
	-3.0	-6

#### NOTE:

- When  $-3.0^{\circ}\text{C}$  ( $-6^{\circ}\text{F}$ ) is corrected on the temperature setting set as  $25.0^{\circ}\text{C}$  ( $77^{\circ}\text{F}$ ) the temperature controlled by A/C auto amp. is  $25.0^{\circ}\text{C}$  ( $77^{\circ}\text{F}$ )  $-3.0^{\circ}\text{C}$  ( $-6^{\circ}\text{F}$ ) =  $22.0^{\circ}\text{C}$  ( $72^{\circ}\text{F}$ ) and the temperature becomes lower than the temperature setting.
- When the battery cable is disconnected from the negative terminal or when the battery voltage becomes 10 V or less, the setting of the difference between the set temperature and control temperature may be cancelled.

### Inlet Port Memory Function (REC)

INFOID:000000009754337

#### DESCRIPTION

- If the ignition switch is turned to the OFF position while the intake switch is set to ON (recirculation), "Perform the memory" or "Do not perform the memory" of intake switch ON (recirculation) condition can be selected.
- If "Perform the memory" was set, the intake switch will be ON (recirculation) when turning the ignition switch to the ON position again.
- If "Do not perform the memory" was set, the air inlets will be controlled automatically when turning the ignition switch to the ON position again.

#### HOW TO SET

Ⓜ With CONSULT

Perform the "REC MEMORY SET" of HVAC work support item.

Work support items	Display	Setting
REC MEMORY SET	WITHOUT (initial status)	Perform the memory of manual REC
	WITH	Do not perform the memory of manual REC (auto control)

#### NOTE:

# SYSTEM SETTING

< BASIC INSPECTION >

[AUTOMATIC AIR CONDITIONING]

When the battery cable is disconnected from the negative terminal or when the battery voltage becomes 10 V or less, the setting of the REC memory function may be cancelled.

## Inlet Port Memory Function (FRE)

INFOID:000000009754338

### DESCRIPTION

- If the ignition switch is turned to the OFF position while the intake switch is set to OFF (fresh air intake), “Perform the memory” or “Do not perform the memory” of intake switch OFF (fresh air intake) condition can be selected.
- If “Perform the memory” was set, the intake switch will be OFF (fresh air intake) when turning the ignition switch to the ON position again.
- If “Do not perform the memory” was set, the air inlets will be controlled automatically when turning the ignition switch to the ON position again.

### HOW TO SET

Ⓟ With CONSULT

Perform the “FRE MEMORY SET” of HVAC work support item.

Work support items	Display	Setting
FRE MEMORY SET	WITHOUT	Perform the memory of manual FRE
	WITH (initial status)	Do not perform the memory of manual FRE (auto control)

### NOTE:

When the battery cable is disconnected from the negative terminal or when the battery voltage becomes 10 V or less, the setting of the FRE memory function may be cancelled.

## Foot Position Setting Trimmer

INFOID:000000009754339

### DESCRIPTION

In FOOT mode, the air blowing to DEF can change ON/OFF.

### HOW TO SET

Ⓟ With CONSULT

Perform the “BLOW SET” of HVAC work support item.

Work support items	Display	Defroster door position	
		Auto control	Manual control
BLOW SET	Mode1 (initial status)	OPEN	CLOSE
	Mode2	OPEN	OPEN
	Mode3	CLOSE	OPEN
	Mode4	CLOSE	CLOSE

### NOTE:

When the battery cable is disconnected from the negative terminal or when the battery voltage becomes 10 V or less, the setting of the discharge air mix ratio in FOOT mode may be cancelled.



# DOOR MOTOR STARTING POSITION RESET

< BASIC INSPECTION >

[AUTOMATIC AIR CONDITIONING]

## DOOR MOTOR STARTING POSITION RESET

### Description

INFOID:000000009754340

- Reset signal is transmitted from A/C auto amp. to air mix door motor and mode door motor. Starting position reset can be performed.

**NOTE:**

- During reset, DEF switch indicator blinks.
- When air mix door motor or mode door motor is removed and installed, always perform door motor starting position reset.

### Work Procedure

INFOID:000000009754341

#### 1. PERFORM DOOR MOTOR STARTING POSITION RESET

④ With CONSULT

1. Turn ignition switch ON.
2. Select "Door Motor Starting Position Reset" in "ACTIVE TEST" mode of "HVAC" using CONSULT.
3. Touch "Start" and wait a few seconds.
4. Make sure the "COMPLETED" is displayed on CONSULT screen.

>> INSPECTION END

A  
B  
C  
D  
E  
F  
G  
H  
J  
K  
L  
M  
N  
O  
P

HAC

# U1000 CAN COMM CIRCUIT

< DTC/CIRCUIT DIAGNOSIS >

[AUTOMATIC AIR CONDITIONING]

## DTC/CIRCUIT DIAGNOSIS

### U1000 CAN COMM CIRCUIT

#### Description

INFOID:000000009754342

CAN (Controller Area Network) is a serial communication line for real time applications. It is an on-board multiplex communication line with high data communication speed and excellent error detection ability. A modern vehicle is equipped with many ECMs, and each control unit shares information and links with other control units during operation (not independent). In CAN communication, 2 control units are connected with 2 communication lines (CAN-L line and CAN-H line) allowing a high rate of information transmission with less wiring. Each control unit transmits/receives data but selectively reads required data only.

Refer to [LAN-28, "CAN COMMUNICATION SYSTEM : CAN Communication Signal Chart"](#) for details of the communication signal.

#### DTC Logic

INFOID:000000009754343

#### DTC DETECTION LOGIC

DTC	Items (CONSULT screen terms)	DTC detection condition	Possible cause
U1000	CAN COMM CIRCUIT	When A/C auto amp. is not transmitting or receiving CAN communication signal for 2 seconds or more.	CAN communication system

#### DTC CONFIRMATION PROCEDURE

##### 1.PERFORM DTC CONFIRMATION PROCEDURE

④ With CONSULT

1. Turn ignition switch ON and wait at least 2 seconds or more.
2. Select "Self Diagnostic Result" mode of "HVAC" using CONSULT.
3. Check DTC.

Is DTC detected?

YES >> Refer to [HAC-50, "Diagnosis Procedure"](#).

NO >> Check intermittent incident. Refer to [GI-46, "Intermittent Incident"](#).

#### Diagnosis Procedure

INFOID:000000009754344

##### 1.CHECK CAN COMMUNICATION SYSTEM

Check CAN communication system. Refer to [LAN-15, "Trouble Diagnosis Flow Chart"](#).

>> INSPECTION END

# U1010 CONTROL UNIT (CAN)

[AUTOMATIC AIR CONDITIONING]

< DTC/CIRCUIT DIAGNOSIS >

## U1010 CONTROL UNIT (CAN)

### Description

INFOID:000000009754345

Initial diagnosis of A/C auto amp.

### DTC Logic

INFOID:000000009754346

### DTC DETECTION LOGIC

DTC	Items (CONSULT screen terms)	DTC detection condition	Possible cause
U1010	CONTROL UNIT(CAN)	When detecting error during the initial diagnosis of CAN controller of A/C auto amp.	A/C auto amp.

### DTC CONFIRMATION PROCEDURE

#### 1.PERFORM DTC CONFIRMATION PROCEDURE

④With CONSULT

1. Turn ignition switch ON.
2. Select "Self Diagnostic Result" mode of "HVAC" using CONSULT.
3. Check DTC.

Is DTC detected?

YES >> Refer to [HAC-51, "Diagnosis Procedure"](#).

NO >> INSPECTION END

### Diagnosis Procedure

INFOID:000000009754347

#### 1.REPLACE A/C AUTO AMP.

Replace A/C auto amp. Refer to [HAC-90, "Removal and Installation"](#).

>> INSPECTION END

A  
B  
C  
D  
E  
F  
G  
H  
HAC  
J  
K  
L  
M  
N  
O  
P

# B2578, B2579 IN-VEHICLE SENSOR

< DTC/CIRCUIT DIAGNOSIS >

[AUTOMATIC AIR CONDITIONING]

## B2578, B2579 IN-VEHICLE SENSOR

### DTC Logic

INFOID:000000009754348

### DTC DETECTION LOGIC

#### NOTE:

- If DTC is displayed along with DTC U1000, first perform the trouble diagnosis for DTC U1000. Refer to [HAC-50, "DTC Logic"](#).
- If DTC is displayed along with DTC U1010, first perform the trouble diagnosis for DTC U1010. [HAC-51, "DTC Logic"](#).

DTC	Items (CONSULT screen terms)	DTC detection condition	Possible cause
B2578	IN-VEHICLE SENSOR	The in-vehicle sensor recognition temperature is too high [more than 100°C (212°F)].	<ul style="list-style-type: none"><li>• In-vehicle sensor</li><li>• A/C auto amp.</li><li>• Harness or connectors (The sensor circuit is open or shorted.)</li></ul>
B2579		The in-vehicle sensor recognition temperature is too low [less than -42°C (-44°F)].	

### DTC CONFIRMATION PROCEDURE

#### 1. PERFORM DTC CONFIRMATION PROCEDURE

##### Ⓟ With CONSULT

1. Turn ignition switch ON.
2. Select "Self Diagnostic Result" mode of "HVAC" using CONSULT.
3. Check DTC.

##### Is DTC detected?

- YES >> Refer to [HAC-52, "Diagnosis Procedure"](#).  
NO >> INSPECTION END

### Diagnosis Procedure

INFOID:000000009754349

#### 1. CHECK IN-VEHICLE SENSOR POWER SUPPLY

1. Turn ignition switch OFF.
2. Disconnect in-vehicle sensor connector.
3. Turn ignition switch ON.
4. Check voltage between in-vehicle sensor harness connector and ground.

+		-	Voltage (Approx.)
In-vehicle sensor			
Connector	Terminal	Ground	5 V
M41	1		

##### Is the inspection result normal?

- YES >> GO TO 2.  
NO >> GO TO 4.

#### 2. CHECK IN-VEHICLE SENSOR GROUND CIRCUIT FOR OPEN

1. Turn ignition switch OFF.
2. Disconnect A/C auto amp. connector.
3. Check continuity between in-vehicle sensor harness connector and A/C auto amp harness connector.

In-vehicle sensor		A/C auto amp.		Continuity
Connector	Terminal	Connector	Terminal	
M41	2	M50	10	Existed

##### Is the inspection result normal?

# B2578, B2579 IN-VEHICLE SENSOR

[AUTOMATIC AIR CONDITIONING]

## < DTC/CIRCUIT DIAGNOSIS >

- YES >> GO TO 3.
- NO >> Repair harness or connector.

### 3.CHECK IN-VEHICLE SENSOR

Check in-vehicle sensor. Refer to [HAC-53, "Component Inspection"](#).

Is the inspection result normal?

- YES >> Replace A/C auto amp. Refer to [HAC-90, "Removal and Installation"](#).
- NO >> Replace in-vehicle sensor. Refer to [HAC-92, "Removal and Installation"](#).

### 4.CHECK IN-VEHICLE SENSOR POWER SUPPLY CIRCUIT FOR OPEN

1. Turn ignition switch OFF.
2. Disconnect A/C auto amp. connector.
3. Check continuity between in-vehicle sensor harness connector and A/C auto amp. harness connector.

In-vehicle sensor		A/C auto amp.		Continuity
Connector	Terminal	Connector	Terminal	
M41	1	M50	2	Existed

Is the inspection result normal?

- YES >> GO TO 5.
- NO >> Repair harness or connector.

### 5.CHECK IN-VEHICLE SENSOR POWER SUPPLY CIRCUIT FOR SHORT

Check continuity between in-vehicle sensor harness connector and ground.

In-vehicle sensor		—	Continuity
Connector	Terminal		
M41	1	Ground	Not existed

Is the inspection result normal?

- YES >> Replace A/C auto amp. Refer to [HAC-90, "Removal and Installation"](#).
- NO >> Repair harness or connector.

## Component Inspection

INFOID:000000009754350

### 1.CHECK IN-VEHICLE SENSOR

1. Remove in-vehicle sensor. Refer to [HAC-92, "Removal and Installation"](#).
2. Check resistance between in-vehicle sensor terminals. Refer to applicable table for the normal value.

A  
B  
C  
D  
E  
F  
G  
H  
J  
K  
L  
M  
N  
O  
P

HAC

# B2578, B2579 IN-VEHICLE SENSOR

< DTC/CIRCUIT DIAGNOSIS >

[AUTOMATIC AIR CONDITIONING]

Terminal		Condition	Resistance: kΩ
		Temperature: °C (°F)	
1	2	-15 (5)	12.73
		-10 (14)	9.92
		-5 (23)	7.80
		0 (32)	6.19
		5 (41)	4.95
		10 (50)	3.99
		15 (59)	3.24
		20 (68)	2.65
		25 (77)	2.19
		30 (86)	1.81
		35 (95)	1.51
		40 (104)	1.27
		45 (113)	1.07

Is the inspection result normal?

YES >> INSPECTION END

NO >> Replace in-vehicle sensor. Refer to [HAC-92. "Removal and Installation"](#).

# B257B, B257C AMBIENT SENSOR

< DTC/CIRCUIT DIAGNOSIS >

[AUTOMATIC AIR CONDITIONING]

## B257B, B257C AMBIENT SENSOR

### DTC Logic

INFOID:000000009754351

### DTC DETECTION LOGIC

#### NOTE:

- If DTC is displayed along with DTC U1000, first perform the trouble diagnosis for DTC U1000. Refer to [HAC-50, "DTC Logic"](#).
- If DTC is displayed along with DTC U1010, first perform the trouble diagnosis for DTC U1010. [HAC-51, "DTC Logic"](#).

DTC	Items (CONSULT screen terms)	DTC detection condition	Possible cause
B257B	AMBIENT SENSOR	The ambient sensor recognition temperature is too high [more than 100°C (212°F)].	<ul style="list-style-type: none"> <li>• Ambient sensor</li> <li>• A/C auto amp.</li> <li>• Harness or connectors (The sensor circuit is open or shorted.)</li> </ul>
B257C		The ambient sensor recognition temperature is too low [less than -42°C (-44°F)].	

### DTC CONFIRMATION PROCEDURE

#### 1. PERFORM DTC CONFIRMATION PROCEDURE

Ⓜ With CONSULT

1. Turn ignition switch ON.
2. Select "Self Diagnostic Result" mode of "HVAC" using CONSULT.
3. Check DTC.

Is DTC detected?

- YES >> Refer to [HAC-55, "Diagnosis Procedure"](#).  
 NO >> INSPECTION END

### Diagnosis Procedure

INFOID:000000009754352

#### 1. CHECK AMBIENT SENSOR POWER SUPPLY

1. Turn ignition switch OFF.
2. Disconnect ambient sensor connector.
3. Turn ignition switch ON.
4. Check voltage between ambient sensor harness connector and ground.

+		-	Voltage (Approx.)
Ambient sensor			
Connector	Terminal	Ground	5 V
E53	1		

Is the inspection result normal?

- YES >> GO TO 2.  
 NO >> GO TO 4.

#### 2. CHECK AMBIENT SENSOR GROUND CIRCUIT FOR OPEN

1. Turn ignition switch OFF.
2. Disconnect A/C auto amp. connector.
3. Check continuity between ambient sensor harness connector and A/C auto amp harness connector.

Ambient sensor		A/C auto amp.		Continuity
Connector	Terminal	Connector	Terminal	
E53	2	M50	10	Existed

Is the inspection result normal?

## B257B, B257C AMBIENT SENSOR

[AUTOMATIC AIR CONDITIONING]

< DTC/CIRCUIT DIAGNOSIS >

- YES >> GO TO 3.  
NO >> Repair harness or connector.

### 3.CHECK AMBIENT SENSOR

Check ambient sensor. Refer to [HAC-56. "Component Inspection"](#).

Is the inspection result normal?

- YES >> Replace A/C auto amp. Refer to [HAC-90. "Removal and Installation"](#).  
NO >> Replace ambient sensor. Refer to [HAC-91. "Removal and Installation"](#).

### 4.CHECK AMBIENT SENSOR POWER SUPPLY CIRCUIT FOR OPEN

1. Turn ignition switch OFF.
2. Disconnect A/C auto amp. connector.
3. Check continuity between ambient sensor harness connector and A/C auto amp. harness connector.

Ambient sensor		A/C auto amp.		Continuity
Connector	Terminal	Connector	Terminal	
E53	1	M50	4	Existed

Is the inspection result normal?

- YES >> GO TO 5.  
NO >> Repair harness or connector.

### 5.CHECK AMBIENT SENSOR POWER SUPPLY CIRCUIT FOR SHORT

Check continuity between ambient sensor harness connector and ground.

Ambient sensor		—	Continuity
Connector	Terminal		
E53	1	Ground	Not existed

Is the inspection result normal?

- YES >> Replace A/C auto amp. Refer to [HAC-90. "Removal and Installation"](#).  
NO >> Repair harness or connector.

## Component Inspection

INFOID:000000009754353

### 1.CHECK AMBIENT SENSOR

1. Remove ambient sensor. Refer to [HAC-91. "Removal and Installation"](#).
2. Check resistance between ambient sensor terminals. Refer to applicable table for the normal value.



# B257B, B257C AMBIENT SENSOR

< DTC/CIRCUIT DIAGNOSIS >

[AUTOMATIC AIR CONDITIONING]

Terminal		Condition	Resistance: kΩ
		Temperature: °C (°F)	
1	2	-15 (5)	12.73
		-10 (14)	9.92
		-5 (23)	7.80
		0 (32)	6.19
		5 (41)	4.95
		10 (50)	3.99
		15 (59)	3.24
		20 (68)	2.65
		25 (77)	2.19
		30 (86)	1.81
		35 (95)	1.51
		40 (104)	1.27
		45 (113)	1.07

Is the inspection result normal?

YES >> INSPECTION END

NO >> Replace ambient sensor. Refer to [HAC-91, "Removal and Installation"](#).

A  
B  
C  
D  
E  
F  
G  
H  
J  
K  
L  
M  
N  
O  
P

HAC

# B2581, B2582 INTAKE SENSOR

< DTC/CIRCUIT DIAGNOSIS >

[AUTOMATIC AIR CONDITIONING]

## B2581, B2582 INTAKE SENSOR

### DTC Logic

INFOID:000000009754354

### DTC DETECTION LOGIC

#### NOTE:

- If DTC is displayed along with DTC U1000, first perform the trouble diagnosis for DTC U1000. Refer to [HAC-50, "DTC Logic"](#).
- If DTC is displayed along with DTC U1010, first perform the trouble diagnosis for DTC U1010. [HAC-51, "DTC Logic"](#).

DTC	Items (CONSULT screen terms)	DTC detection condition	Possible cause
B2581	INTAKE SENSOR	The intake sensor recognition temperature is too high [more than 100°C (212°F)].	<ul style="list-style-type: none"> <li>• Intake sensor</li> <li>• A/C auto amp.</li> <li>• Harness or connectors (The sensor circuit is open or shorted.)</li> </ul>
B2582		The intake sensor recognition temperature is too low [less than -42°C (-44°F)].	

### DTC CONFIRMATION PROCEDURE

#### 1. PERFORM DTC CONFIRMATION PROCEDURE

##### Ⓟ With CONSULT

1. Turn ignition switch ON.
2. Select "Self Diagnostic Result" mode of "HVAC" using CONSULT.
3. Check DTC.

##### Is DTC detected?

- YES >> Refer to [HAC-58, "Diagnosis Procedure"](#).  
 NO >> INSPECTION END

### Diagnosis Procedure

INFOID:000000009754355

#### 1. CHECK INTAKE SENSOR POWER SUPPLY

1. Turn ignition switch OFF.
2. Disconnect intake sensor connector.
3. Turn ignition switch ON.
4. Check voltage between intake sensor harness connector and ground.

+		-	Voltage (Approx.)
Intake sensor			
Connector	Terminal		
M42	1	Ground	5 V

##### Is the inspection result normal?

- YES >> GO TO 2.  
 NO >> GO TO 4.

#### 2. CHECK INTAKE SENSOR GROUND CIRCUIT FOR OPEN

1. Turn ignition switch OFF.
2. Disconnect A/C auto amp. connector.
3. Check continuity between intake sensor harness connector and A/C auto amp harness connector.

Intake sensor		A/C auto amp.		Continuity
Connector	Terminal	Connector	Terminal	
M42	2	M50	10	Existed

##### Is the inspection result normal?

# B2581, B2582 INTAKE SENSOR

[AUTOMATIC AIR CONDITIONING]

< DTC/CIRCUIT DIAGNOSIS >

- YES >> GO TO 3.
- NO >> Repair harness or connector.

## 3.CHECK INTAKE SENSOR

Check intake sensor. Refer to [HAC-59. "Component Inspection"](#).

Is the inspection result normal?

- YES >> Replace A/C auto amp. Refer to [HAC-90. "Removal and Installation"](#).
- NO >> Replace intake sensor. Refer to [HAC-94. "Removal and Installation"](#).

## 4.CHECK INTAKE SENSOR POWER SUPPLY CIRCUIT FOR OPEN

1. Turn ignition switch OFF.
2. Disconnect A/C auto amp. connector.
3. Check continuity between intake sensor harness connector and A/C auto amp. harness connector.

Intake sensor		A/C auto amp.		Continuity
Connector	Terminal	Connector	Terminal	
M42	1	M50	3	Existed

Is the inspection result normal?

- YES >> GO TO 5.
- NO >> Repair harness or connector.

## 5.CHECK INTAKE SENSOR POWER SUPPLY CIRCUIT FOR SHORT

Check continuity between intake sensor harness connector and ground.

Intake sensor		—	Continuity
Connector	Terminal		
M42	1	Ground	Not existed

Is the inspection result normal?

- YES >> Replace A/C auto amp. Refer to [HAC-90. "Removal and Installation"](#).
- NO >> Repair harness or connector.

## Component Inspection

INFOID:000000009754356

## 1.CHECK INTAKE SENSOR

1. Remove intake sensor. Refer to [HAC-94. "Removal and Installation"](#).
2. Check resistance between intake sensor terminals. Refer to applicable table for the normal value.

A  
B  
C  
D  
E  
F  
G  
H  
J  
K  
L  
M  
N  
O  
P

HAC

## B2581, B2582 INTAKE SENSOR

< DTC/CIRCUIT DIAGNOSIS >

[AUTOMATIC AIR CONDITIONING]

Terminal		Condition	Resistance: k $\Omega$
		Temperature: °C (°F)	
1	2	-15 (5)	12.34
		-10 (14)	9.62
		-5 (23)	7.56
		0 (32)	6.00
		5 (41)	4.80
		10 (50)	3.87
		15 (59)	3.15
		20 (68)	2.57
		25 (77)	2.12
		30 (86)	1.76
		35 (95)	1.47
		40 (104)	1.23
		45 (113)	1.04

Is the inspection result normal?

YES >> INSPECTION END

NO >> Replace intake sensor. Refer to [HAC-94. "Removal and Installation"](#).

# B2630, B2631 SUNLOAD SENSOR

< DTC/CIRCUIT DIAGNOSIS >

[AUTOMATIC AIR CONDITIONING]

## B2630, B2631 SUNLOAD SENSOR

### DTC Logic

INFOID:000000009754357

### DTC DETECTION LOGIC

#### NOTE:

- If DTC is displayed along with DTC U1000, first perform the trouble diagnosis for DTC U1000. Refer to [HAC-50, "DTC Logic"](#).
- If DTC is displayed along with DTC U1010, first perform the trouble diagnosis for DTC U1010. [HAC-51, "DTC Logic"](#).
- Sunload sensor may register a malfunction when indoors, at dusk, or at other times when light is insufficient. When performing the diagnosis indoors, use a lamp (60 W or more) that is pointed at the sunload sensor.

DTC	Items (CONSULT screen terms)	DTC detection condition	Possible cause
B2630	SUNLOAD SENSOR	Detected calorie at sunload sensor 1677 W/m <sup>2</sup> (1442 kcal/m <sup>2</sup> ·h) or more.	<ul style="list-style-type: none"> <li>• Sunload sensor</li> <li>• A/C auto amp.</li> <li>• Harness or connectors (The sensor circuit is open or shorted.)</li> </ul>
B2631		Detected calorie at sunload sensor 33 W/m <sup>2</sup> (28 kcal/m <sup>2</sup> ·h) or less.	

### DTC CONFIRMATION PROCEDURE

#### 1. PERFORM DTC CONFIRMATION PROCEDURE

##### Ⓜ With CONSULT

1. Turn ignition switch ON.
2. Select "Self Diagnostic Result" mode of "HVAC" using CONSULT.
3. Check DTC.

##### Is DTC detected?

YES >> Refer to [HAC-61, "Diagnosis Procedure"](#).

NO >> INSPECTION END

### Diagnosis Procedure

INFOID:000000009754358

#### 1. CHECK SUNLOAD SENSOR POWER SUPPLY

1. Turn ignition switch OFF.
2. Disconnect sunload sensor connector.
3. Turn ignition switch ON.
4. Check voltage between sunload sensor harness connector and ground.

+		-	Voltage (Approx.)
Sunload sensor			
Connector	Terminal	Ground	5 V
M74	1		

##### Is the inspection result normal?

YES >> GO TO 2.

NO >> GO TO 4.

#### 2. CHECK SUNLOAD SENSOR GROUND CIRCUIT FOR OPEN

1. Turn ignition switch OFF.
2. Disconnect A/C auto amp. connector.
3. Check continuity between sunload sensor harness connector and A/C auto amp harness connector.

Sunload sensor		A/C auto amp.		Continuity
Connector	Terminal	Connector	Terminal	
M74	2	M50	10	Existed

# B2630, B2631 SUNLOAD SENSOR

[AUTOMATIC AIR CONDITIONING]

< DTC/CIRCUIT DIAGNOSIS >

Is the inspection result normal?

- YES >> GO TO 3.
- NO >> Repair harness or connector.

## 3.CHECK SUNLOAD SENSOR

1. Disconnect A/C auto amp. connector.
2. Check sunload sensor. Refer to [HAC-62, "Component Inspection"](#).

Is the inspection result normal?

- YES >> Replace A/C auto amp. Refer to [HAC-90, "Removal and Installation"](#).
- NO >> Replace sunload sensor. Refer to [HAC-93, "Removal and Installation"](#).

## 4.CHECK SUNLOAD SENSOR POWER SUPPLY CIRCUIT FOR OPEN

1. Turn ignition switch OFF.
2. Disconnect A/C auto amp. connector.
3. Check continuity between sunload sensor harness connector and A/C auto amp. harness connector.

Sunload sensor		A/C auto amp.		Continuity
Connector	Terminal	Connector	Terminal	
M74	1	M50	5	Existed

Is the inspection result normal?

- YES >> GO TO 5.
- NO >> Repair harness or connector.

## 5.CHECK SUNLOAD SENSOR POWER SUPPLY CIRCUIT FOR SHORT

Check continuity between sunload sensor harness connector and ground.

Sunload sensor		—	Continuity
Connector	Terminal		
M74	1	Ground	Not existed

Is the inspection result normal?

- YES >> Replace A/C auto amp. Refer to [HAC-90, "Removal and Installation"](#).
- NO >> Repair harness or connector.

## Component Inspection

INFOID:000000009754359

## 1.CHECK SUNLOAD SENSOR

1. Turn ignition switch ON.
2. Check voltage between A/C auto amp. harness connector and ground. Refer to applicable table for the normal value.

A/C auto amp.		
Connector	+	-
	Terminal	Terminal
M50	5	30

# B2630, B2631 SUNLOAD SENSOR

< DTC/CIRCUIT DIAGNOSIS >

[AUTOMATIC AIR CONDITIONING]

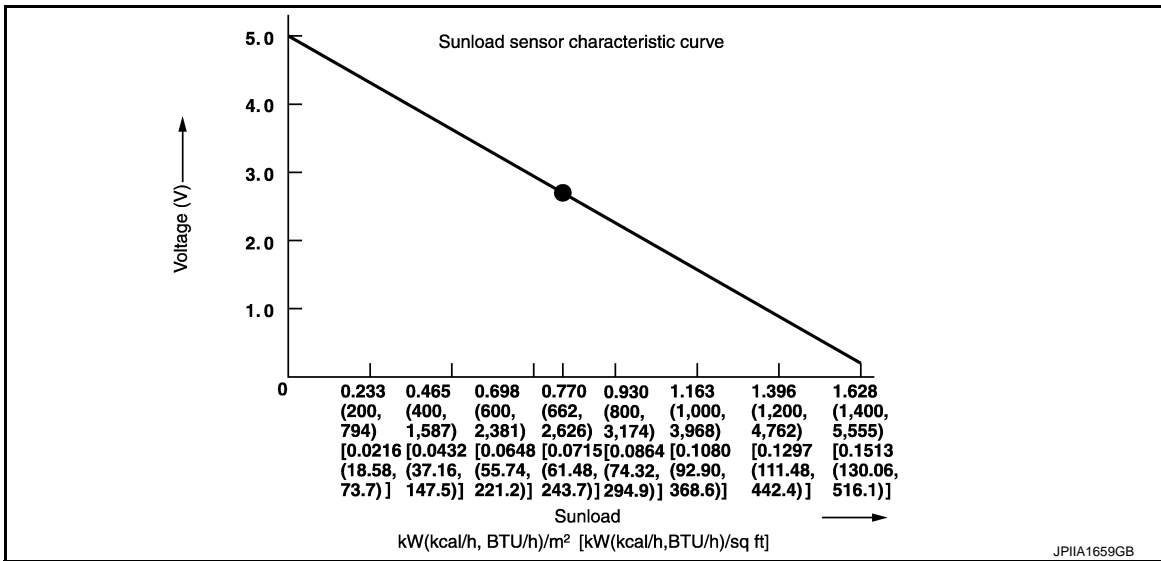

**NOTE:**

- When checking indoors, use a lamp of approximately 60 W. Move the lamp towards and away from the sensor to check.
- The sunload amount produced by direct sunshine in fair weather is equivalent to approximately 0.77 kW/m<sup>2</sup> (662 kcal/m<sup>2</sup>·h).

Is the inspection result normal?

YES >> INSPECTION END

NO >> Replace sunload sensor. Refer to [HAC-93. "Removal and Installation"](#).

A  
B  
C  
D  
E  
F  
G  
H  
J  
K  
L  
M  
N  
O  
P

HAC

# B27A0, B27A1 INTAKE DOOR MOTOR

< DTC/CIRCUIT DIAGNOSIS >

[AUTOMATIC AIR CONDITIONING]

## B27A0, B27A1 INTAKE DOOR MOTOR

### DTC Logic

INFOID:000000009754360

### DTC DETECTION LOGIC

#### NOTE:

- If DTC is displayed along with DTC U1000, first perform the trouble diagnosis for DTC U1000. Refer to [HAC-50, "DTC Logic"](#).
- If DTC is displayed along with DTC U1010, first perform the trouble diagnosis for DTC U1010. [HAC-51, "DTC Logic"](#).

DTC	Items (CONSULT screen terms)	DTC detection condition*	Possible cause
B27A0	INTAKE DOOR MOTOR	PBR opening angle of intake door motor is 50% or more. (PBR feedback signal voltage of intake door motor is 2.5 V or more)	<ul style="list-style-type: none"> <li>• Intake door motor</li> <li>• Intake door motor system installation condition</li> <li>• A/C auto amp.</li> <li>• Harness or connectors (The motor circuit is open or shorted.)</li> </ul>
B27A1		PBR opening angle of intake door motor is 30% or less. (PBR feedback signal voltage of intake door motor is 1.5 V or less)	

\*: A/C auto amp. operates intake door motor according to target value of PBR opening angle at 40% when performing self-diagnosis.

### DTC CONFIRMATION PROCEDURE

#### 1. PERFORM DTC CONFIRMATION PROCEDURE

Ⓟ With CONSULT

1. Start engine.
2. Select "Self Diagnostic Result" mode of "HVAC" using CONSULT.
3. Check DTC.

Is DTC detected?

- YES >> Refer to [HAC-64, "Diagnosis Procedure"](#).  
 NO >> INSPECTION END

### Diagnosis Procedure

INFOID:000000009754361

#### 1. CHECK INTAKE DOOR MOTOR OPERATION

1. Turn ignition switch ON.
2. Operate intake switch and check by operation sound that intake door motor operates.

Does the intake door motor operate?

- YES >> GO TO 2.  
 NO >> GO TO 8.

#### 2. CHECK INTAKE DOOR MOTOR PBR POWER SUPPLY

1. Disconnect intake door motor connector.
2. Turn ignition switch ON.
3. Check voltage between intake door motor harness connector and ground.

+		-	Voltage (Approx.)
Intake door motor			
Connector	Terminal		
M54	1	Ground	5 V

Is the inspection result normal?

- YES >> GO TO 3.  
 NO >> GO TO 7.

#### 3. CHECK INTAKE DOOR MOTOR PBR GROUND CIRCUIT FOR OPEN



# B27A0, B27A1 INTAKE DOOR MOTOR

[AUTOMATIC AIR CONDITIONING]

## < DTC/CIRCUIT DIAGNOSIS >

1. Turn ignition switch OFF.
2. Disconnect A/C auto amp. connector.
3. Check continuity between intake door motor harness connector and A/C auto amp. harness connector.

Intake door motor		A/C auto amp.		Continuity
Connector	Terminal	Connector	Terminal	
M54	3	M50	10	Existed

Is the inspection result normal?

YES >> GO TO 4.

NO >> Repair harness or connector.

### 4.CHECK INTAKE DOOR MOTOR PBR FEEDBACK SIGNAL CIRCUIT FOR OPEN

Check continuity between intake door motor harness connector and A/C auto amp. harness connector.

Intake door motor		A/C auto amp.		Continuity
Connector	Terminal	Connector	Terminal	
M54	2	M50	22	Existed

Is the inspection result normal?

YES >> GO TO 5.

NO >> Repair harness or connector.

### 5.CHECK INTAKE DOOR MOTOR PBR FEEDBACK SIGNAL CIRCUIT FOR SHORT

Check continuity between intake door motor harness connector and ground.

Intake door motor		—	Continuity
Connector	Terminal		
M54	2	Ground	Not existed

Is the inspection result normal?

YES >> GO TO 6.

NO >> Repair harness or connector.

### 6.CHECK INTAKE DOOR MOTOR PBR

Check intake door motor PBR. Refer to [HAC-66, "Component Inspection \(PBR\)".](#)

Is the inspection result normal?

YES >> Replace A/C auto amp. Refer to [HAC-90, "Removal and Installation".](#)

NO >> Replace intake door motor. Refer to [HAC-98, "INTAKE DOOR MOTOR : Removal and Installation".](#)

### 7.CHECK INTAKE DOOR MOTOR PBR POWER SUPPLY CIRCUIT FOR OPEN

1. Turn ignition switch OFF.
2. Disconnect A/C auto amp. connector.
3. Check continuity between intake door motor harness connector and A/C auto amp. harness connector.

Intake door motor		A/C auto amp.		Continuity
Connector	Terminal	Connector	Terminal	
M54	1	M50	8	Existed

Is the inspection result normal?

YES >> Replace A/C auto amp. Refer to [HAC-90, "Removal and Installation".](#)

NO >> Repair harness or connector.

### 8.CHECK INTAKE DOOR MOTOR DRIVE SIGNAL CIRCUIT FOR OPEN

1. Turn ignition switch OFF.
2. Disconnect intake door motor connector, and A/C auto amp. connector.

## B27A0, B27A1 INTAKE DOOR MOTOR

< DTC/CIRCUIT DIAGNOSIS >

[AUTOMATIC AIR CONDITIONING]

3. Check continuity between intake door motor harness connector and A/C auto amp. harness connector.

Intake door motor		A/C auto amp.		Continuity
Connector	Terminal	Connector	Terminal	
M54	5	M50	35	Existed
	6		36	

Is the inspection result normal?

YES >> GO TO 9.

NO >> Repair harness or connector.

### 9.CHECK INTAKE DOOR MOTOR DRIVE SIGNAL CIRCUIT FOR SHORT

Check continuity between intake door motor harness connector and ground.

Intake door motor		—	Continuity
Connector	Terminal		
M54	5	Ground	Not existed
	6		

Is the inspection result normal?

YES >> GO TO 10.

NO >> Repair harness or connector.

### 10.CHECK INTAKE DOOR MOTOR

1. Turn ignition switch OFF.

2. Check intake door motor. Refer to [HAC-66. "Component Inspection \(Motor\)".](#)

Is the inspection result normal?

YES >> GO TO 11.

NO >> Replace intake door motor. Refer to [HAC-98. "INTAKE DOOR MOTOR : Removal and Installation".](#)

### 11.CHECK INSTALLATION OF INTAKE DOOR MOTOR SYSTEM

Check intake door motor system is properly installed. Refer to [HAC-97. "Exploded View".](#)

Is the inspection result normal?

YES >> Replace A/C auto amp. Refer to [HAC-90. "Removal and Installation".](#)

NO >> Repair or replace malfunctioning parts.

## Component Inspection (PBR)

INFOID:000000009754362

### 1.CHECK INTAKE DOOR MOTOR PBR

Check resistance between intake door motor terminals.

Terminal		Resistance (Ω)
1	2	Except 0 or ∞
	3	

Is the inspection result normal?

YES >> INSPECTION END

NO >> Replace intake door motor. Refer to [HAC-98. "INTAKE DOOR MOTOR : Removal and Installation".](#)

## Component Inspection (Motor)

INFOID:000000009754363

### 1.CHECK INTAKE DOOR MOTOR

Supply intake door motor terminals with battery voltage and check by visually and operation sound that intake door motor operates.

# B27A0, B27A1 INTAKE DOOR MOTOR

< DTC/CIRCUIT DIAGNOSIS >

[AUTOMATIC AIR CONDITIONING]

Terminal		Operation direction
+	-	
5	6	REC
6	5	FRE

Is the inspection result normal?

YES >> INSPECTION END

NO >> Replace intake door motor. Refer to [HAC-98. "INTAKE DOOR MOTOR : Removal and Installation"](#).

A  
B  
C  
D  
E  
F  
G  
H  
J  
K  
L  
M  
N  
O  
P

HAC

# B27A2, B27A3, B27A4, B27A5 AIR MIX DOOR MOTOR

< DTC/CIRCUIT DIAGNOSIS >

[AUTOMATIC AIR CONDITIONING]

## B27A2, B27A3, B27A4, B27A5 AIR MIX DOOR MOTOR

### DTC Logic

INFOID:000000009754364

### DTC DETECTION LOGIC

#### NOTE:

- If DTC is displayed along with DTC U1000, first perform the trouble diagnosis for DTC U1000. Refer to [HAC-50, "DTC Logic"](#).
- If DTC is displayed along with DTC U1010, first perform the trouble diagnosis for DTC U1010. [HAC-51, "DTC Logic"](#).
- If air mix door motors DTC (B27A2 – B27A5) are detected, there is probably a disconnected connector or an open circuit in air mix door motor drive power supply harness.

DTC	Items (CONSULT screen terms)	DTC detection condition	Possible cause
B27A2	DR AIR MIX DOOR MOT	Short or open circuit of air mix door motor drive signal terminal 1.	<ul style="list-style-type: none"><li>• Air mix door motor</li><li>• A/C auto amp.</li><li>• Harness or connectors (The motor circuit is open or shorted.)</li></ul>
B27A3		Short or open circuit of air mix door motor drive signal terminal 2.	
B27A4		Short or open circuit of air mix door motor drive signal terminal 3.	
B27A5		Short or open circuit of air mix door motor drive signal terminal 4.	

### DTC CONFIRMATION PROCEDURE

#### 1. PERFORM DTC CONFIRMATION PROCEDURE

##### Ⓟ With CONSULT

1. Turn ignition switch ON.
2. Select "Self Diagnostic Result" mode of "HVAC" using CONSULT.
3. Check DTC.

##### Is DTC detected?

- YES >> Refer to [HAC-68, "Diagnosis Procedure"](#).  
NO >> INSPECTION END

### Diagnosis Procedure

INFOID:000000009754365

#### 1. CHECK AIR MIX DOOR MOTOR POWER SUPPLY

1. Turn ignition switch OFF.
2. Disconnect air mix door motor connector.
3. Turn ignition switch ON.
4. Check voltage between air mix door motor harness connector and ground.

+		-	Voltage
Air mix door motor			
Connector	Terminal		
M55	2	Ground	Battery voltage

##### Is the inspection result normal?

- YES >> GO TO 2.  
NO >> Repair harness or connector between air mix door motor and fuse.

#### 2. CHECK AIR MIX DOOR MOTOR DRIVE SIGNAL CIRCUIT FOR OPEN

1. Turn ignition switch OFF.
2. Disconnect A/C auto amp. connector.
3. Check continuity between air mix door motor harness connector and A/C auto amp. harness connector.

# B27A2, B27A3, B27A4, B27A5 AIR MIX DOOR MOTOR

< DTC/CIRCUIT DIAGNOSIS >

[AUTOMATIC AIR CONDITIONING]

Air mix door motor		A/C auto amp.		Continuity
Connector	Terminal	Connector	Terminal	
M55	3	M50	17	Existed
	6		18	
	1		19	
	4		20	

Is the inspection result normal?

YES >> GO TO 3.

NO >> Repair harness or connector.

## 3. CHECK AIR MIX DOOR MOTOR DRIVE SIGNAL CIRCUIT FOR SHORT

Check continuity between air mix door motor harness connector and A/C auto amp. harness connector.

Air mix door motor		—	Continuity
Connector	Terminal		
M55	3	Ground	Not existed
	6		
	1		
	4		

Is the inspection result normal?

YES >> GO TO 4.

NO >> Repair harness or connector.

## 4. CHECK AIR MIX DOOR MOTOR

Check air mix door motor. Refer to [HAC-69, "Component Inspection"](#).

Is the inspection result normal?

YES >> Replace A/C auto amp. Refer to [HAC-90, "Removal and Installation"](#).

NO >> Replace air mix door motor. Refer to [HAC-99, "AIR MIX DOOR MOTOR : Removal and Installation"](#).

## Component Inspection

INFOID:000000009754366

### 1. CHECK AIR MIX DOOR MOTOR

1. Remove air mix door motor. Refer to [HAC-99, "AIR MIX DOOR MOTOR : Removal and Installation"](#).
2. Check resistance between air mix door motor terminals. Refer to applicable table for the normal value.

Terminal		Resistance (Ω) (Approx.)
2	1	90
	3	
	4	
	6	

Is the inspection result normal?

YES >> INSPECTION END

NO >> Replace air mix door motor. Refer to [HAC-99, "AIR MIX DOOR MOTOR : Removal and Installation"](#).

# B27A6, B27A7, B27A8, B27A9 MODE DOOR MOTOR

< DTC/CIRCUIT DIAGNOSIS >

[AUTOMATIC AIR CONDITIONING]

## B27A6, B27A7, B27A8, B27A9 MODE DOOR MOTOR

### DTC Logic

INFOID:000000009754367

#### DTC DETECTION LOGIC

##### NOTE:

- If DTC is displayed along with DTC U1000, first perform the trouble diagnosis for DTC U1000. Refer to [HAC-50, "DTC Logic"](#).
- If DTC is displayed along with DTC U1010, first perform the trouble diagnosis for DTC U1010. [HAC-51, "DTC Logic"](#).
- If mode door motors DTC (B27A6 – B27A9) are detected, there is probably a disconnected connector or an open circuit in mode door motor drive power supply harness.

DTC	Items (CONSULT screen terms)	DTC detection condition	Possible cause
B27A6	MODE DOOR MOTOR	Short or open circuit of mode door motor drive signal terminal 1.	<ul style="list-style-type: none"><li>• Mode door motor</li><li>• A/C auto amp.</li><li>• Harness or connectors (The motor circuit is open or shorted.)</li></ul>
B27A7		Short or open circuit of mode door motor drive signal terminal 2.	
B27A8		Short or open circuit of mode door motor drive signal terminal 3.	
B27A9		Short or open circuit of mode door motor drive signal terminal 4.	

#### DTC CONFIRMATION PROCEDURE

##### 1. PERFORM DTC CONFIRMATION PROCEDURE

###### ⓑ With CONSULT

1. Turn ignition switch ON.
2. Select "Self Diagnostic Result" mode of "HVAC" using CONSULT.
3. Check DTC.

###### Is DTC detected?

- YES >> Refer to [HAC-70, "Diagnosis Procedure"](#).  
NO >> INSPECTION END

#### Diagnosis Procedure

INFOID:000000009754368

##### 1. CHECK MODE DOOR MOTOR POWER SUPPLY

1. Turn ignition switch OFF.
2. Disconnect mode door motor connector.
3. Turn ignition switch ON.
4. Check voltage between mode door motor harness connector and ground.

+		-	Voltage
Mode door motor			
Connector	Terminal		
M342	5	Ground	Battery voltage

###### Is the inspection result normal?

- YES >> GO TO 2.  
NO >> Repair harness or connector between mode door motor and fuse.

##### 2. CHECK MODE DOOR MOTOR DRIVE SIGNAL CIRCUIT FOR OPEN

1. Turn ignition switch OFF.
2. Disconnect A/C auto amp. connector.
3. Check continuity between mode door motor harness connector and A/C auto amp. harness connector.

# B27A6, B27A7, B27A8, B27A9 MODE DOOR MOTOR

< DTC/CIRCUIT DIAGNOSIS >

[AUTOMATIC AIR CONDITIONING]

Mode door motor		A/C auto amp.		Continuity
Connector	Terminal	Connector	Terminal	
M342	4	M50	37	Existed
	3		38	
	2		39	
	1		40	

Is the inspection result normal?

YES >> GO TO 3.

NO >> Repair harness or connector.

### 3. CHECK MODE DOOR MOTOR DRIVE SIGNAL CIRCUIT FOR SHORT

Check continuity between mode door motor harness connector and A/C auto amp. harness connector.

Mode door motor		—	Continuity
Connector	Terminal		
M342	4	Ground	Not existed
	3		
	2		
	1		

Is the inspection result normal?

YES >> GO TO 4.

NO >> Repair harness or connector.

### 4. CHECK MODE DOOR MOTOR

Check mode door motor. Refer to [HAC-71, "Component Inspection"](#).

Is the inspection result normal?

YES >> Replace A/C auto amp. Refer to [HAC-90, "Removal and Installation"](#).

NO >> Replace mode door motor. Refer to [HAC-98, "MODE DOOR MOTOR : Removal and Installation"](#).

### Component Inspection

INFOID:000000009754369

#### 1. CHECK MODE DOOR MOTOR

1. Remove mode door motor. Refer to [HAC-98, "MODE DOOR MOTOR : Removal and Installation"](#).
2. Check resistance between mode door motor terminals. Refer to applicable table for the normal value.

Terminal		Resistance (Ω) (Approx.)
5	1	90
	2	
	3	
	4	

Is the inspection result normal?

YES >> INSPECTION END

NO >> Replace mode door motor. Refer to [HAC-98, "MODE DOOR MOTOR : Removal and Installation"](#).

# POWER SUPPLY AND GROUND CIRCUIT

< DTC/CIRCUIT DIAGNOSIS >

[AUTOMATIC AIR CONDITIONING]

## POWER SUPPLY AND GROUND CIRCUIT

A/C AUTO AMP.

A/C AUTO AMP. : Diagnosis Procedure

INFOID:000000009754370

### 1. CHECK SYMPTOM

Check symptom (A or B).

Symptom	
A	<ul style="list-style-type: none"><li>Air conditioning system does not activate.</li><li>Air conditioning system cannot be controlled.</li><li>Operation status of air conditioning system is not indicated on display.</li></ul> <b>NOTE:</b> Fail-safe does not activate.
B	<ul style="list-style-type: none"><li>Memory function does not operate normally.</li><li>The setting is not maintained. (It returns to the initial condition)</li></ul>

Which symptom is detected?

- A >> GO TO 2.  
B >> GO TO 5.

### 2. CHECK FUSE

- Turn ignition switch OFF.
- Check 10A fuse (No. 3).

**NOTE:**

Refer to [PG-63, "Fuse and Fusible Link Arrangement"](#).

Is the inspection result normal?

- YES >> GO TO 3.  
NO >> Replace the blown fuse after repairing the affected circuit if a fuse is blown.

### 3. CHECK A/C AUTO AMP. IGNITION POWER SUPPLY

- Disconnect A/C auto amp. connector.
- Turn ignition switch ON.
- Check voltage between A/C auto amp. harness connector and ground.

+		-	Voltage
A/C auto amp.			
Connector	Terminal		
M50	11	Ground	Battery voltage

Is the inspection result normal?

- YES >> GO TO 4.  
NO >> Repair harness or connector between A/C auto amp. and fuse.

### 4. CHECK A/C AUTO AMP. GROUND CIRCUIT FOR OPEN

- Turn ignition switch OFF.
- Check continuity between A/C auto amp. harness connector and ground.

A/C auto amp.		—	Continuity
Connector	Terminal		
M50	30	Ground	Existed

Is the inspection result normal?

- YES >> Replace A/C auto amp. Refer to [HAC-90, "Removal and Installation"](#).  
NO >> Repair harness or connector.

### 5. CHECK FUSE



# POWER SUPPLY AND GROUND CIRCUIT

[AUTOMATIC AIR CONDITIONING]

< DTC/CIRCUIT DIAGNOSIS >

1. Turn ignition switch OFF.
2. Check 10A fuse [No.13, located in fuse block (J/B)].

**NOTE:**

Refer to [PG-62, "Fuse, Connector and Terminal Arrangement"](#).

Is the inspection result normal?

YES >> GO TO 6.

NO >> Replace the blown fuse after repairing the affected circuit if a fuse is blown.

## 6.CHECK A/C AUTO AMP. BATTERY POWER SUPPLY

1. Disconnect A/C auto amp. connector.
2. Check voltage between A/C auto amp. harness connector and ground.

+		-	Voltage
A/C auto amp.			
Connector	Terminal	Ground	Battery voltage
M50	12		

Is the inspection result normal?

YES >> Replace A/C auto amp. Refer to [HAC-90, "Removal and Installation"](#).

NO >> Repair harness or connector between A/C auto amp. and fuse.

A  
B  
C  
D  
E  
F  
G  
H  
J  
K  
L  
M  
N  
O  
P

HAC

A/C ON SIGNAL

Component Function Check

INFOID:000000009754371

1.CHECK A/C ON SIGNAL

④ With CONSULT

1. Turn ignition switch ON.
2. Operate blower motor.
3. Select "AIR CONDITIONER" of "BCM" using CONSULT.
4. Select "AIR COND SW" in "DATA MONITOR" mode.
5. Check A/C ON signal when the A/C switch is operated.

Monitor item	Condition		Status
AIR COND SW	A/C switch	ON (A/C indicator: ON)	On
		OFF (A/C indicator: OFF)	Off

Is the inspection result normal?

- YES >> INSPECTION END  
 NO >> Refer to [HAC-74. "Diagnosis Procedure"](#).

Diagnosis Procedure

INFOID:000000009754372

1.CHECK A/C ON SIGNAL

1. Turn ignition switch OFF.
2. Disconnect A/C auto amp. connector.
3. Turn ignition switch ON.
4. Check output waveform between A/C auto amp. harness connector and ground with using oscilloscope.

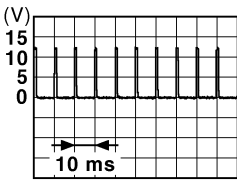
+		-	Output waveform
A/C auto amp.			
Connector	Terminal		
M50	15	Ground	 <p style="text-align: right; font-size: small;">JPMIA0012GB</p>

Is the inspection result normal?

- YES >> Replace A/C auto amp. Refer to [HAC-90. "Removal and Installation"](#).  
 NO >> GO TO 2.

2.CHECK A/C ON SIGNAL CIRCUIT FOR OPEN

1. Turn ignition switch OFF.
2. Disconnect BCM connector.
3. Check continuity between A/C auto amp. harness connector and BCM harness connector.

A/C auto amp.		BCM		Continuity
Connector	Terminal	Connector	Terminal	
M50	15	M68	27	Existed

Is the inspection result normal?

- YES >> GO TO 3.

# A/C ON SIGNAL

< DTC/CIRCUIT DIAGNOSIS >

[AUTOMATIC AIR CONDITIONING]

NO >> Repair harness or connector.

## 3. CHECK A/C ON SIGNAL CIRCUIT FOR SHORT

Check continuity between A/C auto amp. harness connector and ground.

A/C auto amp.		—	Continuity
Connector	Terminal		
M50	15	Ground	Not existed

Is the inspection result normal?

YES >> Replace BCM. Refer to [BCS-90. "Removal and Installation"](#).

NO >> Repair harness or connector.

A  
B  
C  
D  
E  
F  
G  
H  
J  
K  
L  
M  
N  
O  
P

HAC

# BLOWER FAN ON SIGNAL

< DTC/CIRCUIT DIAGNOSIS >

[AUTOMATIC AIR CONDITIONING]

## BLOWER FAN ON SIGNAL

### Component Function Check

INFOID:000000009754373

#### 1.CHECK BLOWER FAN ON SIGNAL

④ With CONSULT

1. Turn ignition switch ON.
2. Select "AIR CONDITIONER" of "BCM" using CONSULT.
3. Select "FAN ON SIG" in "DATA MONITOR" mode.
4. Check blower fan ON signal when the fan control dial is operated.

Monitor item	Condition	Status
FAN ON SIG	Blower motor ON	On
	Blower motor OFF	OFF

Is the inspection result normal?

- YES >> INSPECTION END  
 NO >> Refer to [HAC-76, "Diagnosis Procedure"](#).

### Diagnosis Procedure

INFOID:000000009754374

#### 1.CHECK BLOWER FAN ON SIGNAL

1. Turn ignition switch OFF.
2. Disconnect A/C auto amp. harness connector.
3. Turn ignition switch ON.
4. Check output waveform between A/C auto amp. and ground with using oscilloscope.

+		-	Output waveform
A/C auto amp.			
Connector	Terminal		
M50	14	Ground	

Is the inspection result normal?

- YES >> Replace A/C auto amp. Refer to [HAC-90, "Removal and Installation"](#).  
 NO >> GO TO 2.

#### 2.CHECK BLOWER FAN ON SIGNAL CIRCUIT FOR OPEN

1. Turn ignition switch OFF.
2. Disconnect BCM connector.
3. Check continuity A/C auto amp. harness connector and BCM harness connector.

A/C auto amp.		BCM		Continuity
Connector	Terminal	Connector	Terminal	
M50	14	M68	28	Existed

Is the inspection result normal?

- YES >> GO TO 3.  
 NO >> Repair harness or connector.

#### 3.CHECK BLOWER FAN ON SIGNAL CIRCUIT FOR SHORT

# BLOWER FAN ON SIGNAL

< DTC/CIRCUIT DIAGNOSIS >

[AUTOMATIC AIR CONDITIONING]

Check continuity between A/C auto amp. harness connector and ground.

A/C auto amp.		—	Continuity
Connector	Terminal		
M50	14	Ground	Not existed

Is the inspection result normal?

- YES >> Replace BCM. Refer to [BCS-90. "Removal and Installation"](#).
- NO >> Repair harness or connector.

A  
B  
C  
D  
E  
F  
G  
H  
J  
K  
L  
M  
N  
O  
P

HAC

# BLOWER MOTOR

< DTC/CIRCUIT DIAGNOSIS >

[AUTOMATIC AIR CONDITIONING]

## BLOWER MOTOR

### Diagnosis Procedure

INFOID:00000009754375

#### 1. CHECK FUSE

1. Turn ignition switch OFF.
2. Check following fuses.
  - 10A fuse [No. 15, located in fuse block (J/B)]
  - 15A fuses [Nos. 14 and 16, located in fuse block (J/B)]

**NOTE:**

Refer to [PG-62, "Fuse, Connector and Terminal Arrangement"](#).

Is the inspection result normal?

YES >> GO TO 2.

NO >> Replace the blown fuse after repairing the affected circuit if a fuse is blown.

#### 2. CHECK BLOWER MOTOR POWER SUPPLY

1. Disconnect blower motor connector.
2. Turn ignition switch ON.
3. Check voltage between blower motor harness connector and ground.

+		-	Voltage (Approx.)
Blower motor			
Connector	Terminal	Ground	Battery voltage
M39	1		

Is the inspection result normal?

YES >> GO TO 4.

NO >> GO TO 3.

#### 3. CHECK BLOWER RELAY

1. Turn ignition switch OFF.
2. Check blower relay. Refer to [HAC-81, "Component Inspection \(Blower Relay\)"](#).

Is the inspection result normal?

YES >> Repair harness or connector between blower motor and fuse.

NO >> Replace blower relay.

#### 4. CHECK BLOWER MOTOR CONTROL CIRCUIT

1. Turn ignition switch OFF.
2. Connect blower motor connector.
3. Disconnect power transistor connector.
4. Turn ignition switch ON.
5. Check voltage between power transistor harness connector and ground.

+		-	Voltage (Approx.)
Power transistor			
Connector	Terminal	Ground	Battery voltage
M344	1		

Is the inspection result normal?

YES >> GO TO 6.

NO >> GO TO 5.

#### 5. CHECK BLOWER MOTOR CONTROL CIRCUIT FOR OPEN

1. Turn ignition switch OFF.
2. Disconnect blower motor connector.
3. Check continuity between power transistor harness connector and blower motor harness connector.

# BLOWER MOTOR

< DTC/CIRCUIT DIAGNOSIS >

[AUTOMATIC AIR CONDITIONING]

Power transistor		Blower motor		Continuity
Connector	Terminal	Connector	Terminal	
M344	1	M39	2	Existed

Is the inspection result normal?

- YES >> Replace blower motor. Refer to [VTL-14, "Removal and Installation"](#).  
NO >> Repair harness or connector.

## 6.CHECK A/C AUTO AMP. IGNITION POWER SUPPLY

1. Turn ignition switch OFF.
2. Disconnect A/C auto amp.
3. Turn ignition switch ON.
4. Check voltage between A/C auto amp. harness connector and ground.

+		-	Voltage (Approx.)
A/C auto amp.			
Connector	Terminal		
M50	21	Ground	Battery voltage

Is the inspection result normal?

- YES >> GO TO 7.  
NO >> Repair harness or connector between A/C auto amp. and fuse.

## 7.CHECK POWER TRANSISTOR IGNITION POWER SUPPLY

Check voltage between power transistor harness connector and ground.

+		-	Voltage (Approx.)
Power transistor			
Connector	Terminal		
M344	4	Ground	Battery voltage

Is the inspection result normal?

- YES >> GO TO 8.  
NO >> Repair harness or connector between power transistor and fuse.

## 8.CHECK POWER TRANSISTOR GROUND CIRCUIT FOR OPEN

1. Turn ignition switch OFF.
2. Check continuity between power transistor harness connector and ground.

Power transistor		-	Continuity
Connector	Terminal		
M344	3	Ground	Existed

Is the inspection result normal?

- YES >> GO TO 9.  
NO >> Repair harness or connector.

## 9.CHECK POWER TRANSISTOR CONTROL SIGNAL

1. Connect blower motor connector and A/C auto amp. connector.
2. Turn ignition switch ON.
3. Set air outlet to VENT.
4. Change fan speed from 1st – 7th, and check duty ratios between blower motor harness connector and ground by using an oscilloscope.

### NOTE:

Calculate the drive signal duty ratio as shown in the figure.  
T2 = Approx. 1.6 ms

# BLOWER MOTOR

< DTC/CIRCUIT DIAGNOSIS >

[AUTOMATIC AIR CONDITIONING]

+		-	Condition	Duty ratio (Approx.)	Output waveform
Power transistor					
Connector	Terminal		Fan speed (manual) Air outlet: VENT		
M344	2	Ground	1st	26%	
			2nd	34%	
			3rd	41%	
			4th	51%	
			5th	62%	
			6th	73%	
			7th	82%	

Is the inspection result normal?

- YES >> Replace power transistor. Refer to [HAC-96. "Removal and Installation"](#).
- NO >> GO TO 10.

## 10. CHECK POWER TRANSISTOR CONTROL SIGNAL CIRCUIT FOR OPEN

1. Turn ignition switch OFF.
2. Disconnect power transistor connector and A/C auto amp. connector.
3. Check continuity between power transistor harness connector and A/C auto amp. harness connector.

Power transistor		A/C auto amp.		Continuity
Connector	Terminal	Connector	Terminal	
M344	2	M50	13	Existed

Is the inspection result normal?

- YES >> GO TO 11.
- NO >> Repair harness or connector.

## 11. CHECK POWER TRANSISTOR CONTROL SIGNAL CIRCUIT FOR SHORT

Check continuity between power transistor harness connector and ground.

Power transistor		-	Continuity
Connector	Terminal		
M344	2	Ground	Not existed

Is the inspection result normal?

- YES >> Replace A/C auto amp. Refer to [HAC-90. "Removal and Installation"](#).
- NO >> Repair harness or connector.

## Component Inspection (Blower Motor)

INFOID:000000009754376

### 1. CHECK BLOWER MOTOR

1. Remove blower motor. Refer to [VTL-14. "Removal and Installation"](#).
2. Check that there is not any mixing foreign object in the blower motor.

Is the inspection result normal?

- YES >> GO TO 2.
- NO >> Replace blower motor. Refer to [VTL-14. "Removal and Installation"](#).

### 2. CHECK BLOWER MOTOR

Check that there is not breakage or damage in the blower motor.

Is the inspection result normal?

- YES >> GO TO 3.
- NO >> Replace blower motor. Refer to [VTL-14. "Removal and Installation"](#).



# BLOWER MOTOR

< DTC/CIRCUIT DIAGNOSIS >

[AUTOMATIC AIR CONDITIONING]

## 3.CHECK BLOWER MOTOR

Check that blower motor turns smoothly.

Is the inspection result normal?

YES >> INSPECTION END

NO >> Replace blower motor. Refer to [VTL-14. "Removal and Installation"](#).

## Component Inspection (Blower Relay)

INFOID:000000009754377

### 1.CHECK BLOWER RELAY

1. Remove blower relay. Refer to [PG-62. "Fuse, Connector and Terminal Arrangement"](#).
2. Check continuity between blower relay terminal 3 and 5 when the voltage is supplied between terminal 1 and 2.

Terminal		Voltage	Continuity
3	5	ON	Existed
		OFF	Not existed

Is the inspection result normal?

YES >> INSPECTION END

NO >> Replace blower relay.

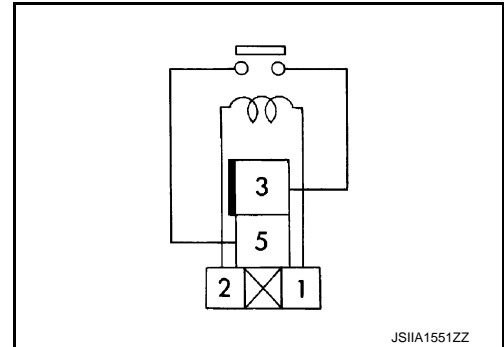

A  
B  
C  
D  
E  
F  
G  
H  
J  
K  
L  
M  
N  
O  
P

HAC

## MAGNET CLUTCH

### Component Function Check

INFOID:000000009754378

#### 1. CHECK MAGNET CLUTCH OPERATION

Perform auto active test of IPDM E/R. Refer to [PCS-12, "Diagnosis Description"](#).

Does it operate normally?

- YES >> INSPECTION END
- NO >> Refer to [HAC-82, "Diagnosis Procedure"](#).

### Diagnosis Procedure

INFOID:000000009754379

#### 1. CHECK FUSE

1. Turn ignition switch OFF.
2. Check 10A fuse (No. 49, located in IPDM E/R).

**NOTE:**

Refer to [PG-64, "Fuse, Connector and Terminal Arrangement"](#).

Is the inspection result normal?

- YES >> GO TO 2.
- NO >> Replace the blown fuse after repairing the affected circuit if a fuse is blown.

#### 2. CHECK MAGNET CLUTCH

1. Disconnect compressor connector.
2. Directly apply battery voltage to the magnet clutch. Check for operation visually and by sound.

Does it operate normally?

- YES >> GO TO 3.
- NO >> Replace magnet clutch. Refer to [HA-30, "MAGNET CLUTCH : Removal and Installation of Compressor Clutch"](#).

#### 3. CHECK MAGNET CLUTCH POWER SUPPLY CIRCUIT FOR OPEN

1. Disconnect IPDM E/R connector.
2. Check continuity between IPDM E/R harness connector and compressor harness connector.

IPDM E/R		Compressor		Continuity
Connector	Terminal	Connector	Terminal	
E15	56	F17	1	Existed

Is the inspection result normal?

- YES >> Replace IPDM E/R. Refer to [PCS-34, "Removal and Installation"](#).
- NO >> Repair harness or connector.

# AUTOMATIC AIR CONDITIONER SYSTEM

< SYMPTOM DIAGNOSIS >

[AUTOMATIC AIR CONDITIONING]

## SYMPTOM DIAGNOSIS

### AUTOMATIC AIR CONDITIONER SYSTEM

#### Symptom Table

INFOID:000000009754380

**NOTE:**

Perform self-diagnoses with CONSULT before performing the symptom diagnosis. If any DTC is detected, perform the corresponding diagnosis.

Symptom	Corresponding malfunction part	Check item/Reference
<ul style="list-style-type: none"> <li>Air conditioning system does not activate.</li> <li>Air conditioning system cannot be controlled.</li> <li>Operation status of air conditioning system is not indicated on display.</li> </ul>	Fail-safe activates	Multi display unit <a href="#">AV-182, "Symptom Table"</a>
	Fail-safe does not activate	<ul style="list-style-type: none"> <li>A/C auto amp. ignition power supply and ground circuit</li> <li>A/C auto amp.</li> </ul>
Discharge air temperature does not change.	Air mix door motor system installation condition	Check air mix door motor system is properly installed. Refer to <a href="#">HAC-97, "Exploded View"</a> .
Air outlet does not change.	Mode door motor system installation condition	Check mode door motor system is properly installed. Refer to <a href="#">HAC-97, "Exploded View"</a> .
Air inlet does not change.	Intake door motor system installation condition	Check intake door motor system is properly installed. Refer to <a href="#">HAC-97, "Exploded View"</a> .
Blower motor does not operate or operation speed is not normal.	<ul style="list-style-type: none"> <li>Blower motor power supply circuit</li> <li>Blower motor control circuit</li> <li>A/C auto amp. ignition power supply circuit</li> <li>Power transistor power supply and ground circuit</li> <li>Power transistor control signal circuit</li> <li>Blower motor</li> <li>Power transistor</li> <li>A/C auto amp.</li> </ul>	<a href="#">HAC-78, "Diagnosis Procedure"</a>
Compressor does not operate.	<ul style="list-style-type: none"> <li>Magnet clutch</li> <li>The circuit between magnet clutch and IPDM E/R</li> <li>IPDM E/R (A/C relay)</li> <li>The circuit between ECM and refrigerant pressure sensor</li> <li>Refrigerant pressure sensor</li> <li>A/C ON signal circuit</li> <li>Blower fan ON signal circuit</li> <li>A/C auto amp.</li> </ul>	<a href="#">HAC-82, "Diagnosis Procedure"</a>
<ul style="list-style-type: none"> <li>Insufficient cooling</li> <li>No cool air comes out. (Air flow volume is normal.)</li> </ul>	<ul style="list-style-type: none"> <li>Magnet clutch control system</li> <li>Drive belt slipping</li> <li>Cooler cycle</li> <li>Air leakage from each duct</li> <li>A/C auto amp. connection recognition signal circuit</li> <li>Temperature setting trimmer</li> </ul>	<a href="#">HAC-85, "Diagnosis Procedure"</a>
<ul style="list-style-type: none"> <li>Insufficient heating</li> <li>No warm air comes out. (Air flow volume is normal.)</li> </ul>	<ul style="list-style-type: none"> <li>Engine cooling system</li> <li>Heater hose</li> <li>Heater core</li> <li>Air leakage from each duct</li> <li>Temperature setting trimmer</li> </ul>	<a href="#">HAC-87, "Diagnosis Procedure"</a>

A  
B  
C  
D  
E  
F  
G  
H  
J  
K  
L  
M  
N  
O  
P

HAC

# AUTOMATIC AIR CONDITIONER SYSTEM

## < SYMPTOM DIAGNOSIS >

## [AUTOMATIC AIR CONDITIONING]

Symptom		Corresponding malfunction part	Check item/Reference
Noise is heard when the A/C system operates.	During compressor operation	Cooler cycle	<a href="#">HA-27, "Symptom Table"</a>
	During blower motor operation	<ul style="list-style-type: none"> <li>• Mixing any foreign object in blower motor</li> <li>• Blower motor fan breakage</li> <li>• Blower motor rotation inferiority</li> </ul>	<a href="#">HAC-80, "Component Inspection (Blower Motor)"</a>
<ul style="list-style-type: none"> <li>• Memory function does not operate normally.</li> <li>• The setting is not maintained. (It returns to initial condition)</li> </ul>		<ul style="list-style-type: none"> <li>• A/C auto amp. battery power supply circuit</li> <li>• A/C auto amp.</li> </ul>	<a href="#">HAC-72, "A/C AUTO AMP. : Diagnosis Procedure"</a>

# INSUFFICIENT COOLING

< SYMPTOM DIAGNOSIS >

[AUTOMATIC AIR CONDITIONING]

## INSUFFICIENT COOLING

### Description

INFOID:000000009754381

#### Symptom

- Insufficient cooling
- No cool air comes out. (Air flow volume is normal.)

### Diagnosis Procedure

INFOID:000000009754382

#### NOTE:

Perform self-diagnoses with CONSULT before performing symptom diagnosis. If any DTC is detected, perform the corresponding diagnosis.

#### 1.CHECK MAGNET CLUTCH OPERATION

1. Turn ignition switch ON.
2. Operate fan control dial.
3. Press A/C switch.
4. Check that A/C indicator turns ON. Check visually and by sound that compressor operates.
5. Press A/C switch again.
6. Check that A/C indicator turns OFF. Check that compressor stops.

#### Is the inspection result normal?

YES >> GO TO 2.

NO >> Perform diagnosis of "COMPRESSOR DOES NOT OPERATE" in "SYMPTOM DIAGNOSIS".  
Refer to [HAC-88, "Diagnosis Procedure"](#).

#### 2.CHECK DRIVE BELT

Check tension of drive belt. Refer to [EM-19, "Inspection"](#).

#### Is the inspection result normal?

YES >> GO TO 3.

NO >> Adjust or replace drive belt depending on the inspection results.

#### 3.CHECK REFRIGERANT CYCLE PRESSURE

Connect recovery/recycling recharging equipment to the vehicle and perform pressure inspection with gauge. Refer to [HA-25, "Symptom Table"](#).

#### Is the inspection result normal?

YES >> GO TO 4.

NO >> Repair or replace parts depending on the inspection results.

#### 4.CHECK AIR LEAKAGE FROM EACH DUCT

Check duct and nozzle, etc. of the air conditioning system for leakage.

#### Is the inspection result normal?

YES >> GO TO 5.

NO >> Repair or replace parts depending on the inspection results.

#### 5.CHECK AMBIENT TEMPERATURE DISPLAY

Check that there is not much difference between actual ambient temperature and indicated temperature on information display in combination meter.

#### Is the inspection result normal?

YES >> GO TO 6.

NO >> Perform diagnosis for the A/C auto amp. connection recognition signal circuit. Refer to [MWI-55, "Diagnosis Procedure"](#).

#### 6.CHECK SETTING OF TEMPERATURE SETTING TRIMMER

1. Check setting value of temperature setting trimmer. Refer to [HAC-47, "Temperature Setting Trimmer"](#).
2. Check that temperature setting trimmer is set to "+ direction".

#### NOTE:

The control temperature can be set with the setting of the temperature setting trimmer.

## INSUFFICIENT COOLING

< SYMPTOM DIAGNOSIS >

[AUTOMATIC AIR CONDITIONING]

---

3. Set difference between the set temperature and control temperature to "0".

Is inspection result normal?

YES >> INSPECTION END

NO >> Replace A/C auto amp. Refer to [HAC-90. "Removal and Installation"](#).

# INSUFFICIENT HEATING

[AUTOMATIC AIR CONDITIONING]

< SYMPTOM DIAGNOSIS >

## INSUFFICIENT HEATING

### Description

INFOID:000000009754383

#### Symptom

- Insufficient heating
- No warm air comes out. (Air flow volume is normal.)

### Diagnosis Procedure

INFOID:000000009754384

#### NOTE:

Perform self-diagnoses with CONSULT before performing symptom diagnosis. If any DTC is detected, perform the corresponding diagnosis.

#### 1.CHECK COOLING SYSTEM

1. Check engine coolant level and check for leakage. Refer to [CO-8, "Inspection"](#).
2. Check radiator cap. Refer to [CO-12, "RADIATOR CAP : Inspection"](#).
3. Check water flow sounds of the engine coolant. Refer to [CO-9, "Refilling"](#).

#### Is the inspection result normal?

YES >> GO TO 2.

NO >> Refill engine coolant and repair or replace the parts depending on the inspection results.

#### 2.CHECK HEATER HOSE

Check installation of heater hose by visually or touching.

#### Is the inspection result normal?

YES >> GO TO 3.

NO >> Repair or replace parts depending on the inspection results.

#### 3.CHECK HEATER CORE

1. Check temperature of inlet hose and outlet hose of heater core.
2. Check that inlet side of heater core is hot and the outlet side is slightly lower than/almost equal to the inlet side.

#### **CAUTION:**

**Always perform the temperature inspection in a short period of time because the engine coolant temperature is very hot.**

#### Is the inspection result normal?

YES >> GO TO 4.

NO >> Replace heater core. Refer to [HA-46, "HEATER CORE : Removal and Installation"](#).

#### 4.CHECK AIR LEAKAGE FROM EACH DUCT

Check duct and nozzle, etc. of the air conditioning system for air leakage.

#### Is the inspection result normal?

YES >> GO TO 5.

NO >> Repair or replace parts depending on the inspection results.

#### 5.CHECK SETTING OF TEMPERATURE SETTING TRIMMER

1. Check setting value of temperature setting trimmer. Refer to [HAC-47, "Temperature Setting Trimmer"](#).
2. Check that temperature setting trimmer is set to "– direction".

#### NOTE:

The control temperature can be set by the temperature setting trimmer.

3. Set difference between the set temperature and control temperature to "0".

#### Are the symptoms solved?

YES >> INSPECTION END

NO >> Replace A/C auto amp. Refer to [HAC-90, "Removal and Installation"](#).

A

B

C

D

E

F

G

H

HAC

J

K

L

M

N

O

P

# COMPRESSOR DOES NOT OPERATE

< SYMPTOM DIAGNOSIS >

[AUTOMATIC AIR CONDITIONING]

## COMPRESSOR DOES NOT OPERATE

### Description

INFOID:000000009754385

### SYMPTOM

Compressor does not operate.

### Diagnosis Procedure

INFOID:000000009754386

#### NOTE:

- Perform self-diagnoses with CONSULT before performing symptom diagnosis. If any DTC is detected, perform the corresponding diagnosis.
- Check that refrigerant is enclosed in cooler cycle normally. If refrigerant amount is shortage from proper amount, perform the inspection of refrigerant leakage.

#### 1. CHECK MAGNET CLUTCH OPERATION

Check magnet clutch. Refer to [HAC-82, "Component Function Check"](#).

Does it operate normally?

- YES >> GO TO 2.  
NO >> Repair or replace malfunctioning parts.

#### 2. CHECK REFRIGERANT PRESSURE SENSOR

Check refrigerant pressure sensor. Refer to [EC-539, "Component Function Check"](#).

Is the inspection result normal?

- YES >> GO TO 3.  
NO >> Repair or replace malfunctioning parts.

#### 3. CHECK A/C ON SIGNAL

Check A/C ON signal. Refer to [HAC-74, "Component Function Check"](#).

Is inspection result normal?

- YES >> GO TO 4.  
NO >> Repair or replace malfunctioning parts.

#### 4. CHECK BLOWER FAN ON SIGNAL

Check blower fan ON signal. Refer to [HAC-76, "Component Function Check"](#).

Is the inspection result normal?

- YES >> GO TO 5.  
NO >> Repair or replace malfunctioning parts

#### 5. CHECK BCM OUTPUT SIGNAL

Ⓔ With CONSULT

1. Select "DATA MONITOR" mode of "ENGINE" using CONSULT.
2. Select "AIR COND SIG" and "HEATER FAN SW", and check status under the following conditions.

Monitor item	Condition	Status
AIR COND SIG	A/C switch	OFF (A/C indicator: OFF)
		ON (A/C indicator: ON)
HEATER FAN SW	Blower motor	OFF
		ON

Is the inspection result normal?

- YES >> Replace IPDM E/R. Refer to [PCS-34, "Removal and Installation"](#).  
NO >> Replace BCM. Refer to [BCS-90, "Removal and Installation"](#).



**REMOVAL AND INSTALLATION**

**CONTROLLER**

**Removal and Installation**

INFOID:000000009754387

**REMOVAL**

Remove multi display unit. Refer to [IP-13. "Removal and Installation"](#).

**INSTALLATION**

Install in the reverse order of removal.

- A
- B
- C
- D
- E
- F
- G
- H
- HAC
- J
- K
- L
- M
- N
- O
- P

HAC

## A/C AUTO AMP.

### Removal and Installation

INFOID:000000009754388

#### REMOVAL

1. Remove audio unit. Refer to the following.
  - Refer to [AV-68. "Removal and Installation"](#). (Without navigation)
  - Refer to [AV-139. "Removal and Installation"](#). (With navigation)
2. Remove inside key antenna (instrument center). Refer to [DLK-173. "INSTRUMENT CENTER : Removal and Installation"](#).
3. Remove fixing screws (A), and then remove A/C auto amp..

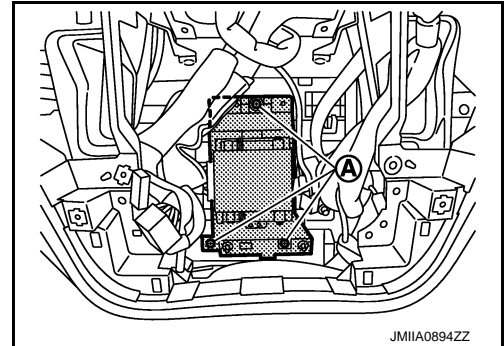

JMIA0894ZZ

#### INSTALLATION

Install in the reverse order of removal.

# AMBIENT SENSOR

< REMOVAL AND INSTALLATION >

[AUTOMATIC AIR CONDITIONING]

## AMBIENT SENSOR

### Removal and Installation

INFOID:000000009754389

#### REMOVAL

1. Remove bumper fascia assembly. Refer to [EXT-15, "Removal and Installation"](#).
2. Disengage fixing pawl, and then remove ambient sensor (1).

 : Pawl

3. Disconnect ambient sensor connector (2), and then remove ambient sensor.

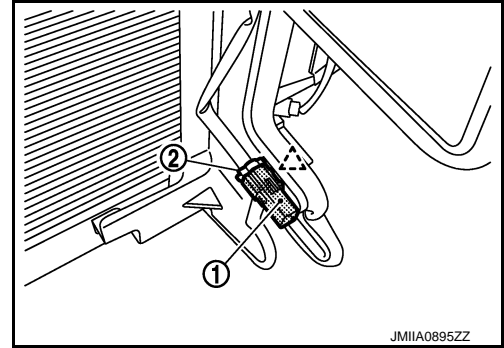

#### INSTALLATION

Install in the reverse order of removal.

A

B

C

D

E

F

G

H

HAC

J

K

L

M

N

O

P

## IN-VEHICLE SENSOR

< REMOVAL AND INSTALLATION >

[AUTOMATIC AIR CONDITIONING]

---

### IN-VEHICLE SENSOR

#### Removal and Installation

INFOID:000000009754390

#### REMOVAL

1. Remove instrument lower panel LH. Refer to [IP-13. "Removal and Installation"](#).
2. Remove fixing screw, and then remove in-vehicle sensor.

#### INSTALLATION

Install in the reverse order of removal.

# SUNLOAD SENSOR

< REMOVAL AND INSTALLATION >

[AUTOMATIC AIR CONDITIONING]

## SUNLOAD SENSOR

### Removal and Installation

INFOID:000000009754391

#### REMOVAL

1. Remove switch panel. Refer to [IP-13. "Removal and Installation"](#).
2. Disconnect sunload sensor connector, and then remove sunload sensor.

#### INSTALLATION

Install in the reverse order of removal.

A

B

C

D

E

F

G

H

HAC

J

K

L

M

N

O

P

## INTAKE SENSOR

### Exploded View

INFOID:000000009754392

Refer to [HA-39. "Exploded View \(Automatic Air Conditioning\)"](#).

### Removal and Installation

INFOID:000000009754393

#### REMOVAL

1. Remove evaporator assembly. Refer to [HA-46. "EVAPORATOR : Removal and Installation"](#).
2. Remove intake sensor from evaporator.

#### INSTALLATION

Note the following items, and then install in the order of removal.

**CAUTION:**

- Replace O-rings with new ones. Then apply the compressor oil to them when installing.
- Mark the mounting position of intake sensor bracket prior to removal so that the reinstalled sensor can be located in the same position.
- Never rotate the bracket insertion part when removing and installing the intake sensor.
- Check for leakages when recharging refrigerant. Refer to [HA-17. "Leak Test"](#).

# REFRIGERANT PRESSURE SENSOR

< REMOVAL AND INSTALLATION >

[AUTOMATIC AIR CONDITIONING]

## REFRIGERANT PRESSURE SENSOR

### Exploded View

INFOID:000000009754394

Refer to [HA-36. "Exploded View"](#).

### Removal and Installation

INFOID:000000009754395

### REMOVAL

Refer to [HA-38. "REFRIGERANT PRESSURE SENSOR : Removal and Installation"](#).

### INSTALLATION

Install in the reverse order of removal.

A

B

C

D

E

F

G

H

HAC

J

K

L

M

N

O

P

# POWER TRANSISTOR

< REMOVAL AND INSTALLATION >

[AUTOMATIC AIR CONDITIONING]

## POWER TRANSISTOR

Exploded View

INFOID:000000009754396

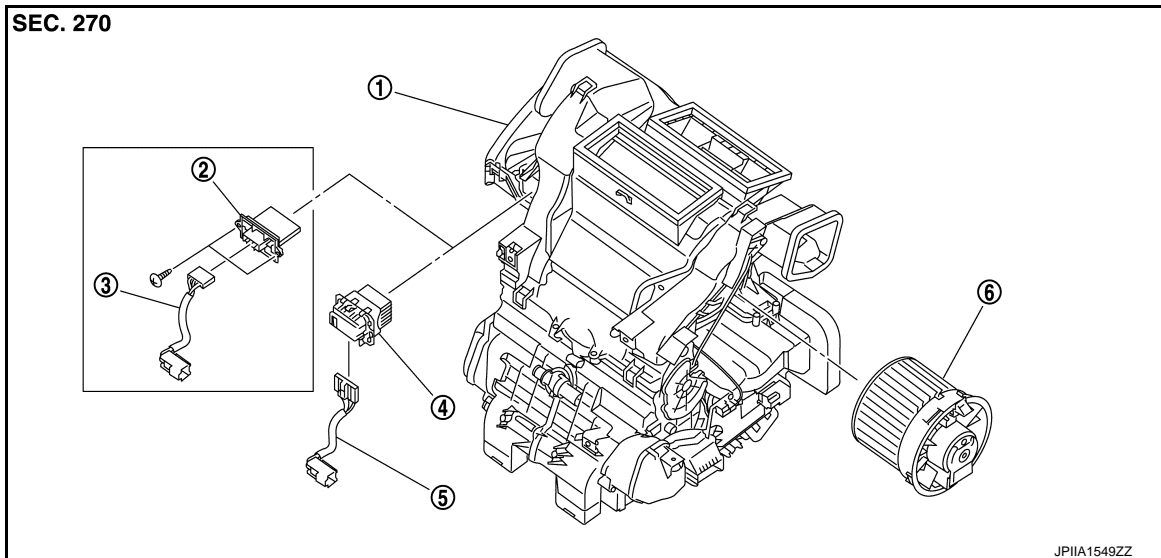

- |                       |                          |                  |
|-----------------------|--------------------------|------------------|
| 1. A/C unit assembly  | 2. Blower fan resistor*1 | 3. Sub harness*1 |
| 4. Power transistor*2 | 5. Sub harness*2         | 6. Blower motor  |

- \*1: Manual air conditioning
- \*2: Automatic air conditioning

## Removal and Installation

INFOID:000000009754397

### REMOVAL

1. Remove instrument panel assembly. Refer to [IP-13, "Removal and Installation"](#).
2. Disconnect power transistor connector.
3. Slide power transistor (1) to the left while pressing lever (A), and then remove power transistor.

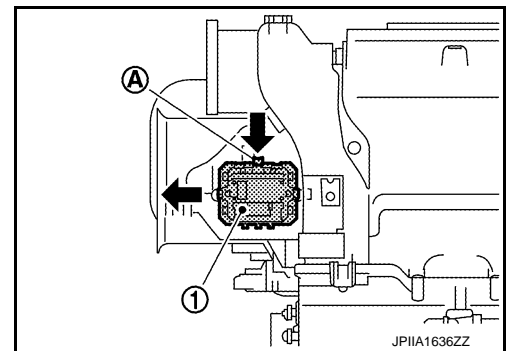

### INSTALLATION

Install in the reverse order of removal.



# DOOR MOTOR

< REMOVAL AND INSTALLATION >

[AUTOMATIC AIR CONDITIONING]

## DOOR MOTOR

Exploded View

INFOID:000000009754398

LEFT SIDE

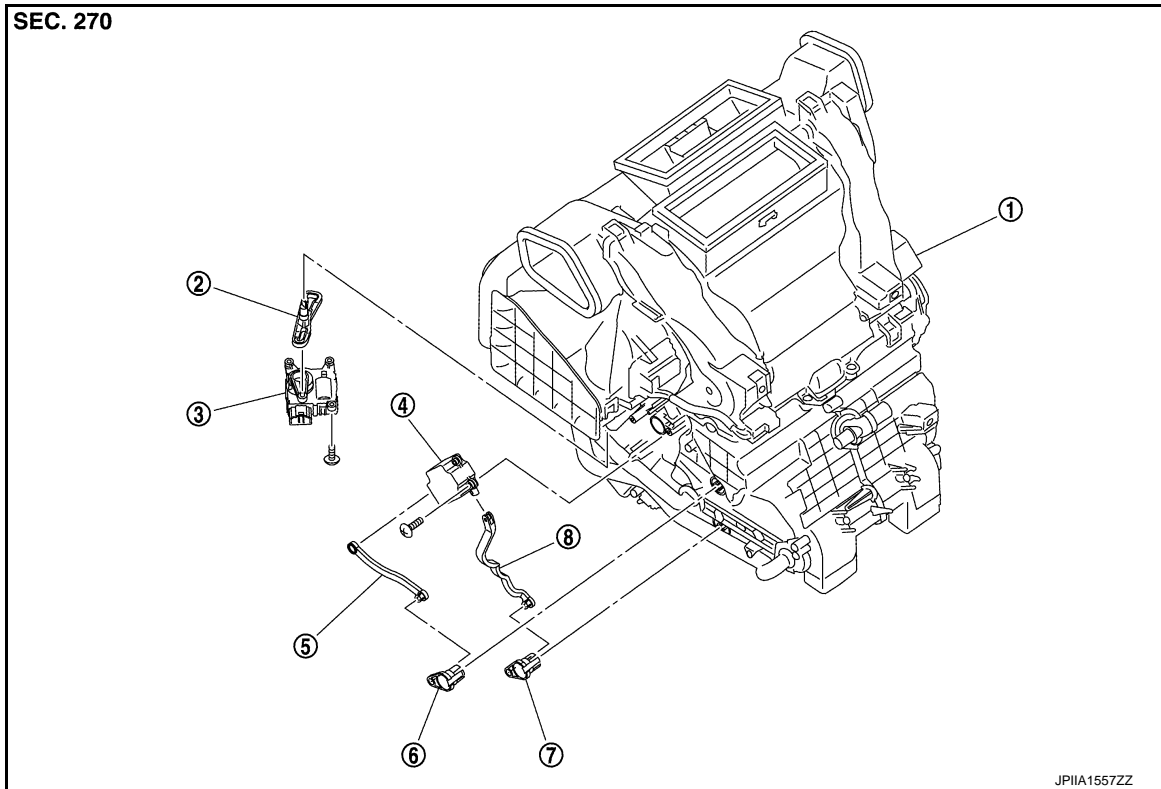

- |                             |                           |                             |
|-----------------------------|---------------------------|-----------------------------|
| 1. A/C unit assembly        | 2. Intake door lever      | 3. Intake door motor        |
| 4. Air mix door motor       | 5. Upper air mix door rod | 6. Upper air mix door lever |
| 7. Lower air mix door lever | 8. Lower air mix door rod |                             |

RIGHT SIDE

A  
B  
C  
D  
E  
F  
G  
H  
HAC  
J  
K  
L  
M  
N  
O  
P

# DOOR MOTOR

< REMOVAL AND INSTALLATION >

[AUTOMATIC AIR CONDITIONING]

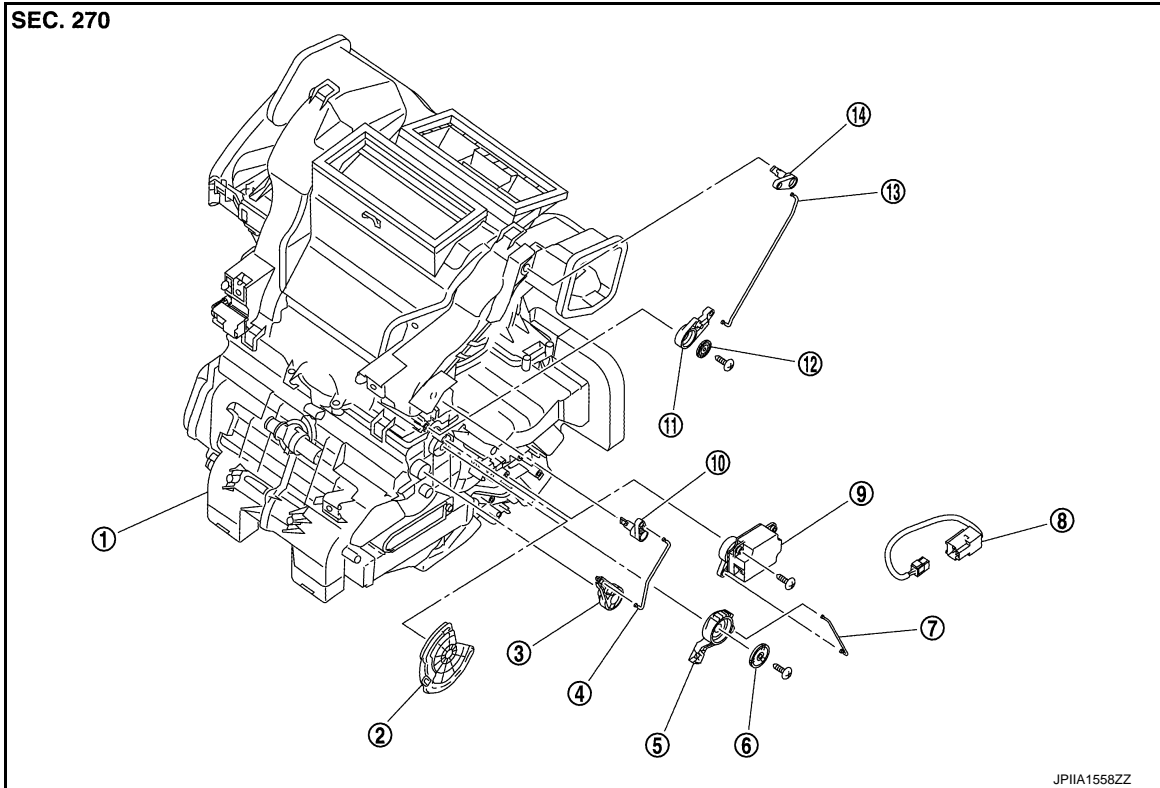

- |  |  |                            |
|--|--|----------------------------|
| 1. A/C unit assembly                         | 2. Main link                                   | 3. Sub defroster door link |
| 4. Sub defroster door rod                    | 5. Mode link                                   | 6. Plate                   |
| 7. Mode link rod                             | 8. Sub harness                                 | 9. Mode door motor         |
| 10. Sub defroster door lever                 | 11. Center ventilator and defroster door link  | 12. Plate                  |
| 13. Center ventilator and defroster door rod | 14. Center ventilator and defroster door lever |                            |

## INTAKE DOOR MOTOR

### INTAKE DOOR MOTOR : Removal and Installation

INFOID:000000009754399

#### REMOVAL

1. Remove instrument lower panel LH. Refer to [IP-13, "Removal and Installation"](#).
2. Remove fixing screws (A), and then remove intake door motor (1).
3. Disconnect intake door motor connector (2).

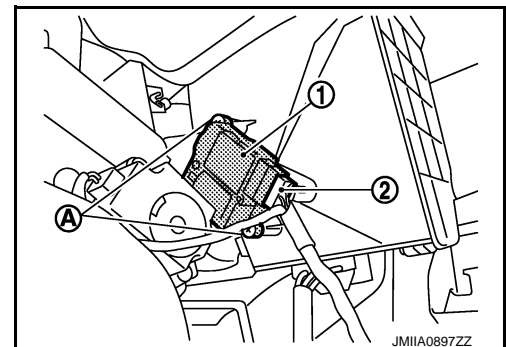

#### INSTALLATION

Install in the reverse order of removal.

## MODE DOOR MOTOR

### MODE DOOR MOTOR : Removal and Installation

INFOID:000000009754400

#### REMOVAL

# DOOR MOTOR

## < REMOVAL AND INSTALLATION >

[AUTOMATIC AIR CONDITIONING]

1. Remove glove box assembly Refer to [IP-13, "Removal and Installation"](#).
2. Remove foot duct RH. Refer to [VTL-13, "FOOT DUCT : Removal and Installation"](#).
3. Disconnect mode link rod from mode door motor.
4. Remove fixing screws (A), and then remove mode door motor (1).
5. Disconnect mode door motor connector (2).

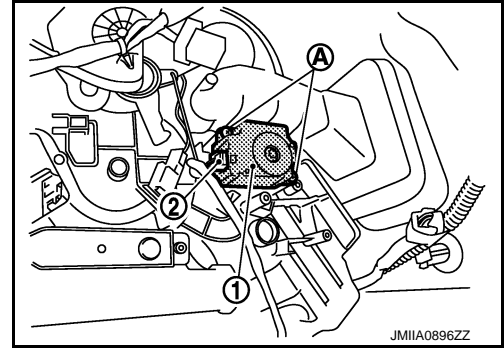

## INSTALLATION

Install in the reverse order of removal.

## AIR MIX DOOR MOTOR

### AIR MIX DOOR MOTOR : Removal and Installation

INFOID:000000009754401

## REMOVAL

1. Set the temperature at full cold.

### **CAUTION:**

**Always perform the above procedure when removing air mix door motor. Otherwise, air mix door may interfere in A/C unit assembly may be damaged.**

2. Remove instrument lower panel LH. Refer to [IP-13, "Removal and Installation"](#).
3. Remove fixing screws (A), and then remove air mix door motor (1).
4. Disconnect air mix door motor connector (2).

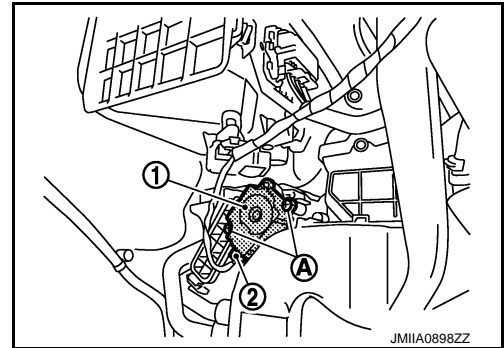

## INSTALLATION

Note the following item, and then install in the reverse order of removal.

### **CAUTION:**

**After installing door motor, perform door motor starting position. Refer to [HAC-49, "Work Procedure"](#).**

## PRECAUTION

### PRECAUTIONS

#### Precaution for Supplemental Restraint System (SRS) "AIR BAG" and "SEAT BELT PRE-TENSIONER"

INFOID:000000009754402

The Supplemental Restraint System such as "AIR BAG" and "SEAT BELT PRE-TENSIONER", used along with a front seat belt, helps to reduce the risk or severity of injury to the driver and front passenger for certain types of collision. This system includes seat belt switch inputs and dual stage front air bag modules. The SRS system uses the seat belt switches to determine the front air bag deployment, and may only deploy one front air bag, depending on the severity of a collision and whether the front occupants are belted or unbelted. Information necessary to service the system safely is included in the "SRS AIR BAG" and "SEAT BELT" of this Service Manual.

**WARNING:**

Always observe the following items for preventing accidental activation.

- To avoid rendering the SRS inoperative, which could increase the risk of personal injury or death in the event of a collision that would result in air bag inflation, all maintenance must be performed by an authorized NISSAN/INFINITI dealer.
- Improper maintenance, including incorrect removal and installation of the SRS, can lead to personal injury caused by unintentional activation of the system. For removal of Spiral Cable and Air Bag Module, see "SRS AIR BAG".
- Never use electrical test equipment on any circuit related to the SRS unless instructed to in this Service Manual. SRS wiring harnesses can be identified by yellow and/or orange harnesses or harness connectors.

#### PRECAUTIONS WHEN USING POWER TOOLS (AIR OR ELECTRIC) AND HAMMERS

**WARNING:**

Always observe the following items for preventing accidental activation.

- When working near the Air Bag Diagnosis Sensor Unit or other Air Bag System sensors with the ignition ON or engine running, never use air or electric power tools or strike near the sensor(s) with a hammer. Heavy vibration could activate the sensor(s) and deploy the air bag(s), possibly causing serious injury.
- When using air or electric power tools or hammers, always switch the ignition OFF, disconnect the battery, and wait at least 3 minutes before performing any service.

#### Precautions for Removing of Battery Terminal

INFOID:000000010286676

- When removing the 12V battery terminal, turn OFF the ignition switch and wait at least 30 seconds.

**NOTE:**

ECU may be active for several tens of seconds after the ignition switch is turned OFF. If the battery terminal is removed before ECU stops, then a DTC detection error or ECU data corruption may occur.

- For vehicles with the 2-batteries, be sure to connect the main battery and the sub battery before turning ON the ignition switch.

**NOTE:**

If the ignition switch is turned ON with any one of the terminals of main battery and sub battery disconnected, then DTC may be detected.

- After installing the 12V battery, always check "Self Diagnosis Result" of all ECUs and erase DTC.

**NOTE:**

The removal of 12V battery may cause a DTC detection error.

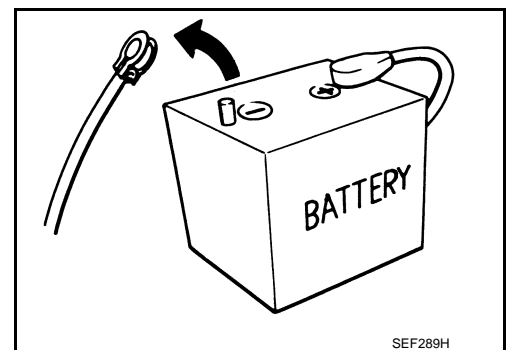

SYSTEM DESCRIPTION

COMPONENT PARTS

Component Part Location

INFOID:000000009754403

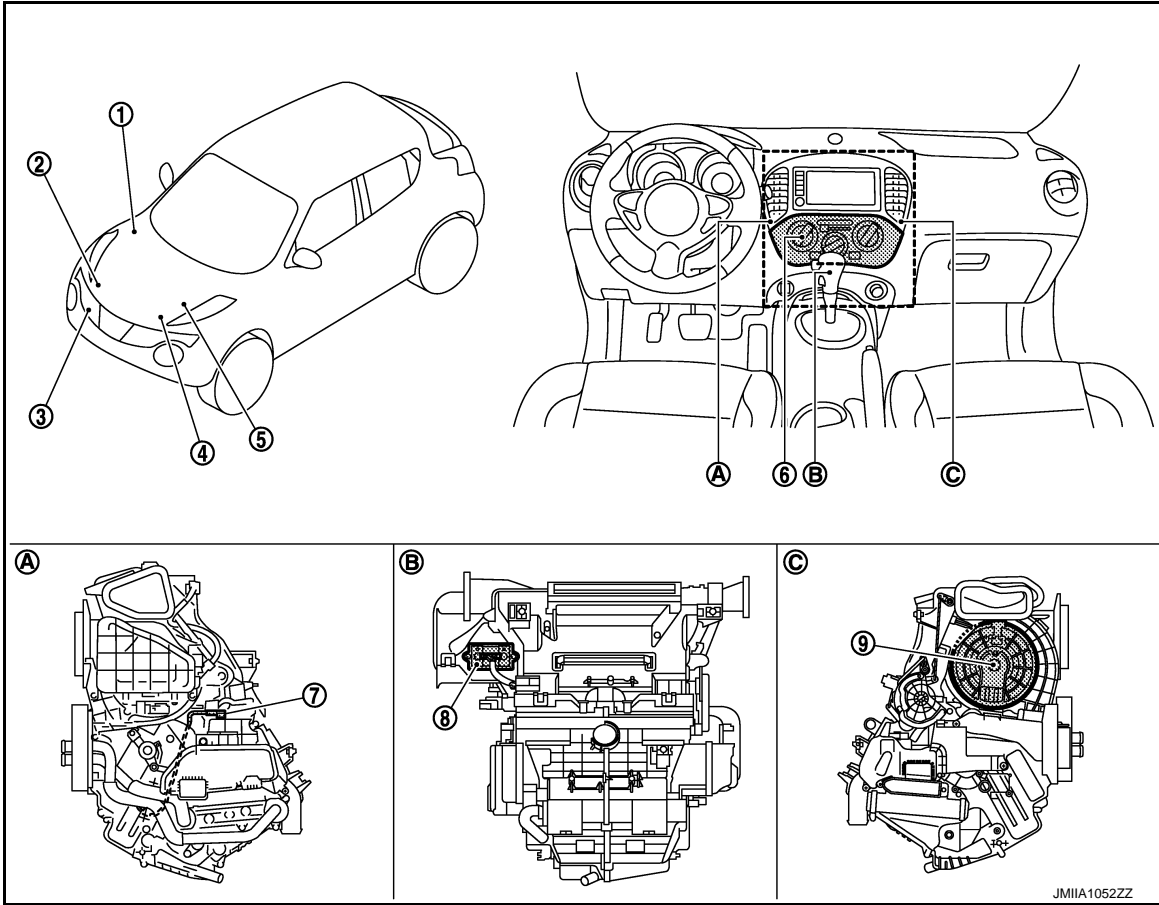

- 1. BCM  
Refer to [BCS-93. "BODY CONTROL SYSTEM : Component Parts Location"](#).
- 2. Magnet clutch
- 3. Refrigerant pressure sensor
- 4. ECM  
Refer to [EC-14. "ENGINE CONTROL SYSTEM : Component Parts Location"](#).
- 5. IPDM E/R  
Refer to [PCS-37. "Component Parts Location"](#).
- 6. A/C control
- 7. Thermo control amp.
- 8. Blower fan resistor
- 9. Blower motor
- A. Left side of A/C unit assembly
- B. Back side of A/C unit assembly
- C. Right side of A/C unit assembly

Component Description

INFOID:000000009754404

Component		Description
A/C unit assembly	Thermo control amp.	<a href="#">HAC-102</a>
	Blower motor	<a href="#">HAC-102</a>
	Blower fan resistor	<a href="#">HAC-102</a>
A/C control		<a href="#">HAC-102</a>
BCM		<a href="#">HAC-103</a>
ECM		<a href="#">HAC-103</a>

# COMPONENT PARTS

< SYSTEM DESCRIPTION >

[MANUAL AIR CONDITIONING]

Component	Description
IPDM E/R	<a href="#">HAC-103</a>
Refrigerant pressure sensor	<a href="#">HAC-103</a>
Magnet clutch	<a href="#">HAC-103</a>

## A/C UNIT ASSEMBLY

### A/C UNIT ASSEMBLY : Thermo Control Amp.

INFOID:000000009754405

- Thermo control amp. is composed of thermistor and amplifier. Thermistor is installed on evaporator, and amplifier is attached to foot duct.
- When the thermistor detecting temperature of the evaporator fin is extremely low, thermo control amp. sends the thermo control amp. OFF signal to BCM, and stops the compressor.

### A/C UNIT ASSEMBLY : Blower Motor

INFOID:000000009754406

- The blower motor utilizes a brush-less motor with a rotating magnet.
- Quietness is improved over previous motors where the brush was the point of contact and the coil rotated.

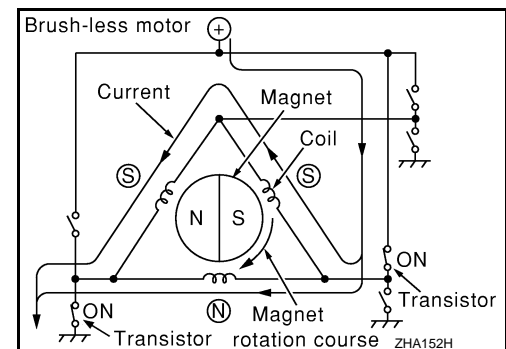
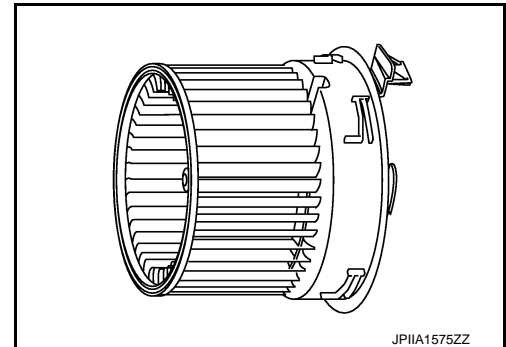

### A/C UNIT ASSEMBLY : Blower Fan Resistor

INFOID:000000009754407

- Compact and lightweight resistor is adopted with outstanding ventilation.
- Temperature fuse is installed to protect the blower motor circuit.

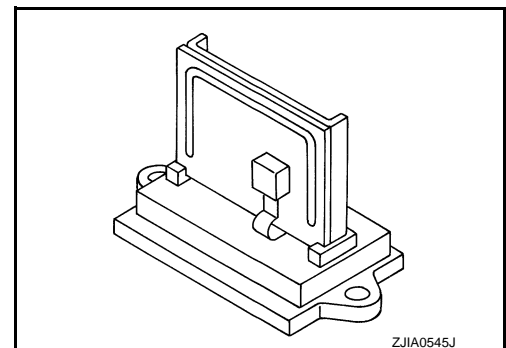

## A/C Control

INFOID:000000009754408

Controls the air conditioning function.

# COMPONENT PARTS

< SYSTEM DESCRIPTION >

[MANUAL AIR CONDITIONING]

## BCM

INFOID:000000009754409

BCM transmits A/C ON signal and blower fan ON signal to ECM via CAN communication, according to A/C switch signal and blower fan ON signal that are received from A/C control and thermo control amp. signal that is received from thermo control amp. At this moment, BCM turns A/C indicator ON.

## ECM

INFOID:000000009754410

ECM, when receiving A/C ON signal and blower fan ON signal from BCM, transmits A/C compressor request signal to IPDM E/R via CAN communication according to status of the engine and refrigerant pressure.

## IPDM E/R

INFOID:000000009754411

A/C relay is integrated in IPDM E/R. IPDM E/R operates A/C relay when A/C compressor request signal is received from ECM via CAN communication line.

## Refrigerant Pressure Sensor

INFOID:000000009754412

### DESCRIPTION

- The refrigerant pressure sensor converts high-pressure side refrigerant pressure into voltage and outputs it to ECM.
- ECM operates cooler cycle protection and cooling fan speed control according to voltage value that is input.

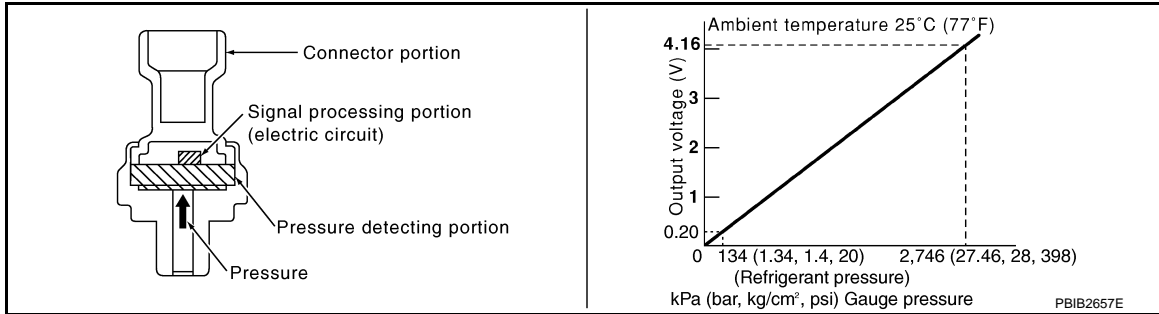

### STRUCTURE AND OPERATION

- The refrigerant pressure sensor is a capacitance type sensor. It consists of a pressure detection area and a signal processing area.
- The pressure detection area, which is a variable capacity condenser, changes internal static capacitance according to pressure force.
- The signal processing area detects the static capacitance of the pressure detection area, converts the static capacitance into a voltage value, and transmits the voltage value to ECM.

## Magnet Clutch

INFOID:000000009754413

Compressor is driven by the magnet clutch which is magnetized by electric power supply.

A  
B  
C  
D  
E  
F  
G  
H  
J  
K  
L  
M  
N  
O  
P

HAC

SYSTEM

System Diagram

INFOID:000000009754414

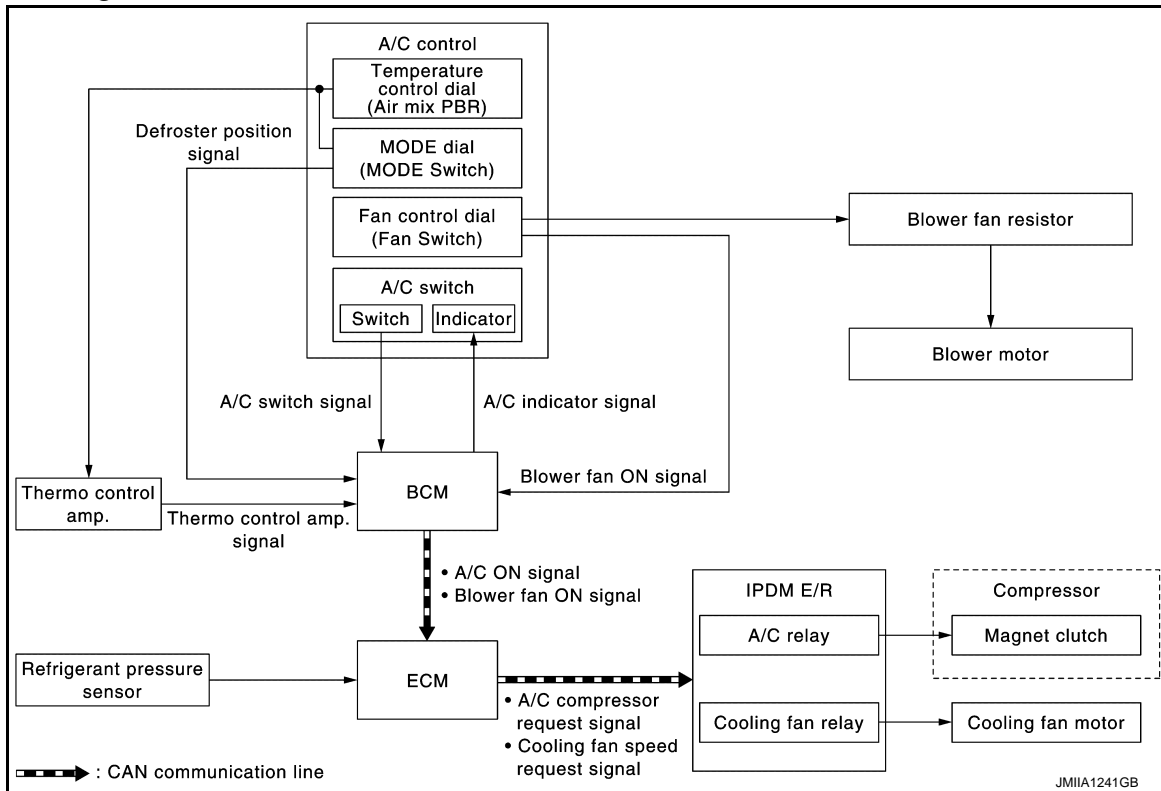

JMIIA1241GB

System Description

INFOID:000000009754415

DESCRIPTION

- Manual air conditioning system is controlled by each function of thermo control amp., BCM, ECM and IPDM E/R.
- Fan speed of blower motor is changed by the combination of fan control dial operation and blower fan resistor control.

CONTROL BY THERMO CONTROL AMP.

[HAC-104, "Compressor Control"](#)

CONTROL BY BCM

[HAC-104, "Compressor Control"](#)

CONTROL BY ECM

- [HAC-104, "Compressor Control"](#)
- Cooling fan control: Refer to [EC-52, "COOLING FAN CONTROL : System Description"](#).

CONTROL BY IPDM E/R

- [HAC-104, "Compressor Control"](#)
- Cooling fan control: Refer to [PCS-40, "POWER CONTROL SYSTEM : System Description"](#)

Compressor Control

INFOID:000000009754416

DESCRIPTION

- BCM transmits the A/C ON signal and blower fan ON signal to ECM via CAN communication line only when the compressor operational condition is satisfied, and A/C indicator is turned ON. Refer to [BCS-99, "SIGNAL BUFFER SYSTEM : System Description"](#).

NOTE:

- Compressor operational condition
  - A/C switch signal ON or defroster position signal ON



### < SYSTEM DESCRIPTION >

- Blower fan ON signal: ON
- Thermo control amp. signal: ON
- ECM judges the conditions of each sensor (Refrigerant pressure sensor signal, accelerator position signal, etc.), and transmits the A/C compressor request signal to IPDM E/R via CAN communication line.
- By receiving the A/C compressor request signal from ECM, IPDM E/R turns the A/C relay to ON, and activates the compressor.

Refer to [PCS-38. "RELAY CONTROL SYSTEM : System Description"](#).

### CONTROL BY THERMO CONTROL AMP.

#### Low Temperature Protection Control

- When the thermo control amp. detects that evaporator fin temperature is 2°C (36°F) or less, thermo control amp. signal becomes OFF, and stops the compressor.
- When the air temperature returns to 3.5°C (38°F) or more, the compressor is activated.

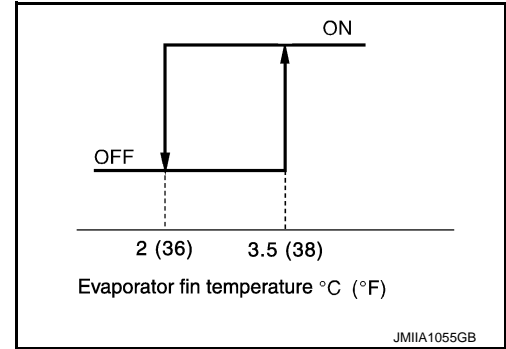

#### Operating Rate Control

- Thermo control amp. detects the positions of temperature control dial (air mix PBR) and MODE dial (MODE switch).
- Thermo control amp. corrects the stopping temperature of A/C compressor depending on the condition of A/C operation, and prevents too much heating by turning thermo control amp. signal ON ⇔ OFF.

### CONTROL BY ECM

#### Compressor Protection Control at Pressure Malfunction

When the high-pressure side value that is detected by refrigerant pressure sensor is as per the following state, ECM requests IPDM E/R to turn A/C relay OFF and stops the compressor.

- 3.12 MPa (31.82 kg/cm<sup>2</sup>, 452.4 psi) or more (When the engine speed is less than 1,500 rpm)
- 2.74 MPa (27.95 kg/cm<sup>2</sup>, 397.3 psi) or more (When the engine speed is 1,500 rpm or more)
- 0.14 MPa (1.43 kg/cm<sup>2</sup>, 20.3 psi) or less

#### Compressor Oil Circulation Control

When the engine starts while the engine coolant temperature is 56°C (133°F) or less, ECM activates the compressor for approximately 6 seconds and circulates the compressor oil once.

#### Air Conditioning Cut Control

When the engine condition is high load, ECM transmit A/C relay OFF request to IPDM E/R, and stops the compressor.

Refer to [EC-50. "AIR CONDITIONING CUT CONTROL : System Description"](#).

### Door Control

INFOID:000000009754417

### SWITCHES AND THEIR CONTROL FUNCTIONS

# SYSTEM

< SYSTEM DESCRIPTION >

[MANUAL AIR CONDITIONING]

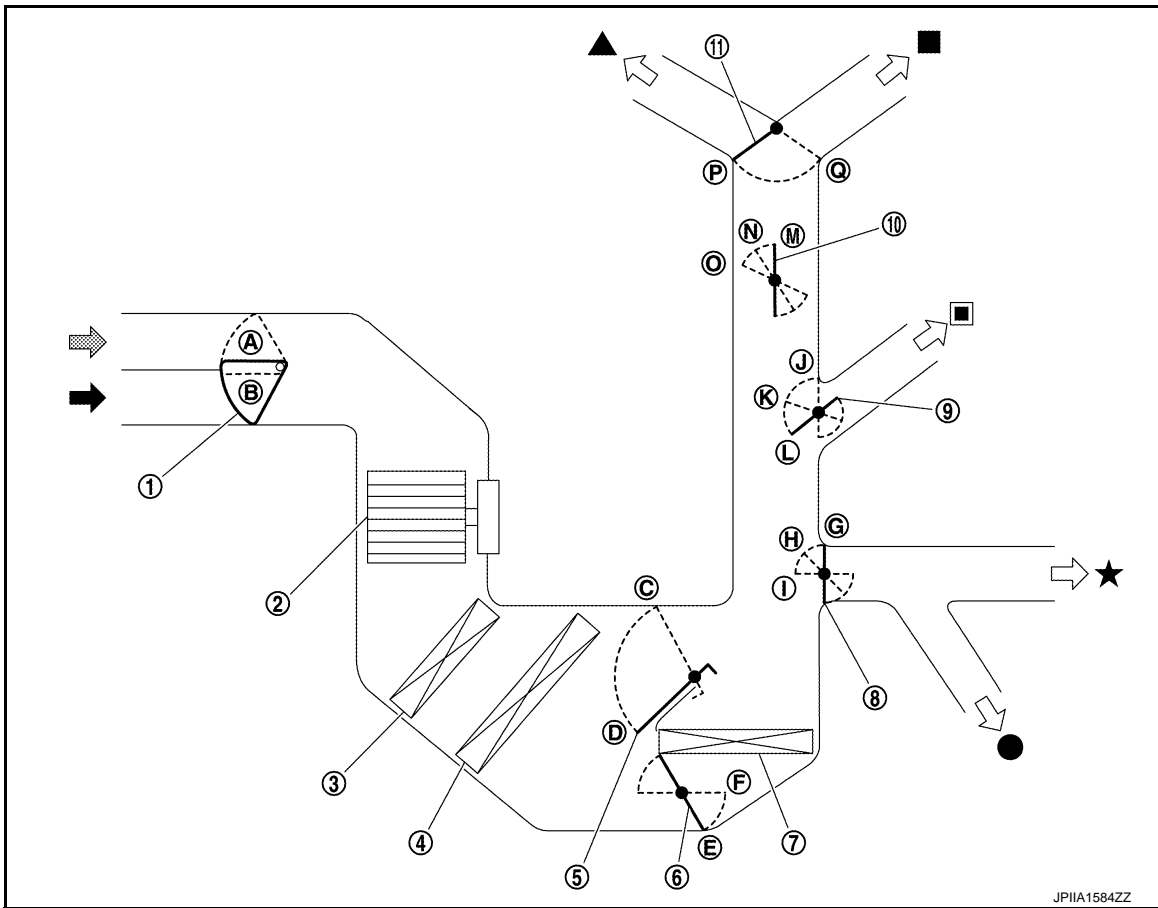

- |                        |  |                           |
|------------------------|--|---------------------------|
| 1. Intake door         | 2. Blower motor                          | 3. Air conditioner filter |
| 4. Evaporator          | 5. Upper air mix door                    | 6. Lower air mix door     |
| 7. Heater core         | 8. Foot door                             | 9. Side ventilator door   |
| 10. Sub defroster door | 11. Center ventilator and defroster door |                           |
| ← Fresh air intake     | ← Recirculation air                      | ▲ Defroster               |
| ■ Center ventilator    | ■ Side ventilator                        | ★ Foot                    |
| ● Rear foot*           |  |                           |

\*: Models for Canada

# SYSTEM

< SYSTEM DESCRIPTION >

[MANUAL AIR CONDITIONING]

Dial/Lever position		Door position						
		Center ventilator and defroster door	Sub defroster door	Side ventilator door	Foot door	Intake door	Upper air mix door	Lower air mix door
MODE dial		P	M	L	G	—	—	—
			N	K	H			
		Q	O	J	I			
			N		G			
			M					
Intake lever		—	—	—	—	A		
						B		
Temperature control dial	Full cold	—	—	—	—	—	D	E
	Full hot						C	F

## AIR DISTRIBUTION

Models except for Canada

Discharge air flow				
MODE dial position	Air outlet/distribution			
	Ventilator		Foot	Defroster
	Center	Side		
	52.6%	47.3%	—	—
	34.0%	27.7%	38.4%	—
	—	19.1%	57.9%	23.0%
	—	13.5%	42.4%	44.1%
	—	16.3%	—	83.8%

Models for Canada

Discharge air flow					
MODE dial position	Air outlet/distribution				
	Ventilator		Foot		Defroster
	Center	Side	Front	Rear	
	52.6%	47.3%	—	—	—
	28.2%	25.9%	29.6%	16.3%	—
	—	16.3%	43.0%	21.0%	19.7%
	—	12.2%	33.1%	16.3%	38.4%
	—	16.3%	—	—	83.8%

## OPERATION

### Switch Name and Function

INFOID:000000009754418

#### A/C CONTROLLER (A/C CONTROL)

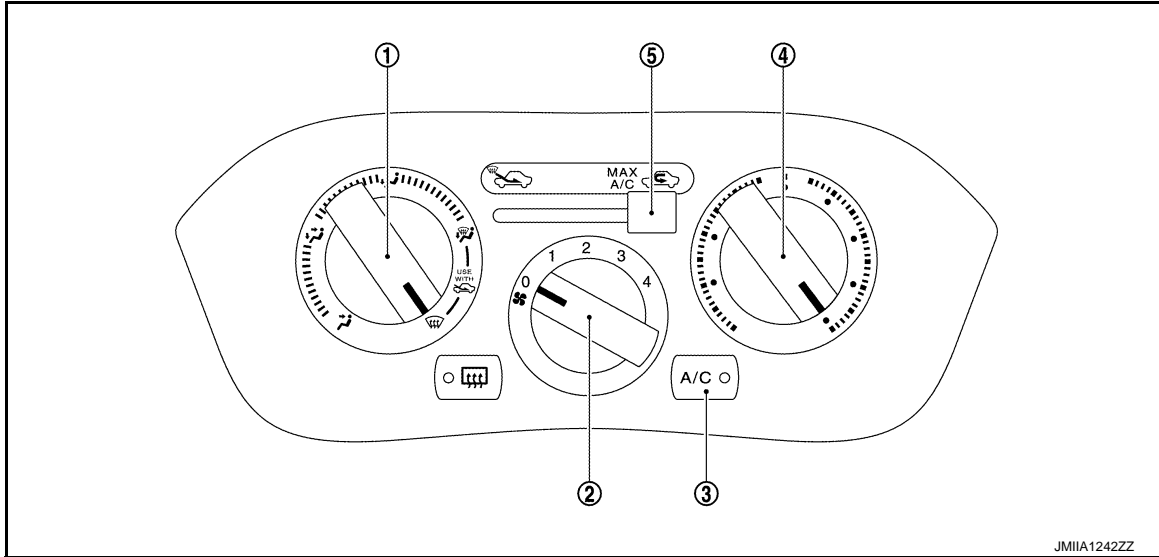

- |                             |                     |               |
|-----------------------------|---------------------|---------------|
| 1. MODE dial                | 2. Fan control dial | 3. A/C switch |
| 4. Temperature control dial | 5. Intake lever     |               |

MODE dial	<ul style="list-style-type: none"> <li>Mode position is selected to an optimal position by operating this dial.</li> <li>When D/F or DEF is selected while blower motor is activated, the compressor automatically turns ON.</li> </ul> <p><b>NOTE:</b> A/C switch (compressor control) is turned ON when D/F or DEF is selected while A/C switch indicator is OFF, but A/C switch indicator is not illuminated.</p>
Fan control dial	Fan speed can be adjusted within a range from 1st to 4th.
A/C switch	<p>The compressor control (A/C switch indicator) is turned ON ⇔ OFF each time by pressing this switch while the blower motor is activated.</p> <p><b>NOTE:</b> A/C switch (compressor control) is turned ON when D/F or DEF is selected while A/C switch indicator is OFF, but A/C switch indicator is not illuminated.</p>
Temperature control dial	<p>The setting temperature can be selected to an optimum temperature by operating this dial.</p> <ul style="list-style-type: none"> <li>Clockwise rotation: Discharge air flow temperature increases</li> <li>Counterclockwise rotation: Discharge air flow temperature decreases.</li> </ul>
Intake lever	The air inlet changes REC ⇔ FRE each time by operation this lever.

# DIAGNOSIS SYSTEM (BCM)

< SYSTEM DESCRIPTION >



[MANUAL AIR CONDITIONING]

## DIAGNOSIS SYSTEM (BCM)

### Description

INFOID:000000009754419

Air conditioning system performs self-diagnosis, operation check, function diagnosis, and various settings using diagnosis function of each control unit.

ECU	Diagnostic item (CONSULT)	
BCM	 BCM-AIR CONDITIONER	Self Diagnostic Result
		Data Monitor
		Active Test
ECM	 ENGINE	Self Diagnostic Result
		Data Monitor
IPDM E/R	 IPDM E/R	Self Diagnostic Result
		Data Monitor
		Auto active test

### COMMON ITEM

#### COMMON ITEM : CONSULT Function (BCM - COMMON ITEM)

INFOID:000000009754420

#### APPLICATION ITEM

CONSULT performs the following functions via CAN communication with BCM.

Diagnosis mode	Function Description
Work Support	Changes the setting for each system function.
Self Diagnostic Result	Displays the diagnosis results judged by BCM.
CAN Diag Support Monitor	Monitors the reception status of CAN communication viewed from BCM.
Data Monitor	The BCM input/output signals are displayed.
Active Test	The signals used to activate each device are forcibly supplied from BCM.
Ecu Identification	The BCM part number is displayed.
Configuration	<ul style="list-style-type: none"> <li>Read and save the vehicle specification.</li> <li>Write the vehicle specification when replacing BCM.</li> </ul>

### SYSTEM APPLICATION

BCM can perform the following functions for each system.

#### NOTE:

It can perform the diagnosis modes except the following for all sub system selection items.

x: Applicable item

System	Sub system selection item	Diagnosis mode		
		Work Support	Data Monitor	Active Test
Door lock	DOOR LOCK	×	×	×
Rear window defogger	REAR DEFOGGER		×	×
Warning chime	BUZZER		×	×
Interior room lamp control	INT LAMP	×	×	×
Remote keyless entry system	MULTI REMOTE ENT	×	×	×
Exterior lamp	HEAD LAMP	×	×	×
Wiper and washer	WIPER	×	×	×
Turn signal and hazard warning lamps	FLASHER		×	×
Air conditioning system	AIR CONDITONER		×	×
Combination switch	COMB SW		×	

# DIAGNOSIS SYSTEM (BCM)

< SYSTEM DESCRIPTION >

[MANUAL AIR CONDITIONING]

System	Sub system selection item	Diagnosis mode		
		Work Support	Data Monitor	Active Test
Body control system	BCM	×		
NATS	IMMU	×		×
Interior room lamp battery saver	BATTERY SAVER	×	×	×
Back door open	TRUNK		×	
Theft warning alarm	THEFT ALM	×	×	×
RAP system	RETAINED PWR		×	×
Signal buffer system	SIGNAL BUFFER		×	×
Panic alarm	PANIC ALARM			×
TPMS	AIR PRESSUE MONITOR	×	×	×

## AIR CONDITIONER

### AIR CONDITIONER : CONSULT Function (BCM - AIR CONDITIONER) (Manual A/C)

INFOID:000000009754421

#### DATA MONITOR

##### NOTE:

The following table includes information (items) inapplicable to this vehicle. For information (items) applicable to this vehicle, refer to CONSULT display items.

##### Display item list

Monitor Item [Unit]	Contents
FAN ON SIG [On/Off]	Displays blower motor status as judged from blower fan ON signal.
AIR COND SW [On/Off]	Displays A/C switch status as judged from A/C switch signal.
THERMO AMP [On/Off]	Displays thermo control amp. status as judged from thermo control amp. signal.
IGN SW [On/Off]	Displays ignition switch position status as judged from ignition switch signal.
FR DEF SW [On/Off]	Displays the D/F or DEF status as judged from defroster position signal.

#### ACTIVE TEST

Test item	Operation	Description
A/C INDICATOR	On	A/C indicator is turned ON.
	Off	A/C indicator is turned OFF.

# ECU DIAGNOSIS INFORMATION

BCM, ECM, IPDM E/R

List of ECU Reference

INFOID:000000009754422

ECU	Reference
BCM	<a href="#">BCS-118, "Reference Value"</a>
	<a href="#">BCS-131, "Fail-safe"</a>
	<a href="#">BCS-132, "DTC Inspection Priority Chart"</a>
	<a href="#">BCS-132, "DTC Index"</a>
ECM	<a href="#">EC-82, "Reference Value"</a>
	<a href="#">EC-97, "Fail Safe"</a>
	<a href="#">EC-99, "DTC Inspection Priority Chart"</a>
	<a href="#">EC-101, "DTC Index"</a>
IPDM E/R	<a href="#">PCS-47, "Reference Value"</a>
	<a href="#">PCS-52, "Fail-safe"</a>
	<a href="#">PCS-53, "DTC Index"</a>

A  
B  
C  
D  
E  
F  
G  
H  
J  
K  
L  
M  
N  
O  
P

HAC

# MANUAL AIR CONDITIONING SYSTEM

[MANUAL AIR CONDITIONING]

< WIRING DIAGRAM >

## WIRING DIAGRAM

### MANUAL AIR CONDITIONING SYSTEM

#### Wiring Diagram

INFOID:000000009754423

### MANUAL AIR CONDITIONING SYSTEM

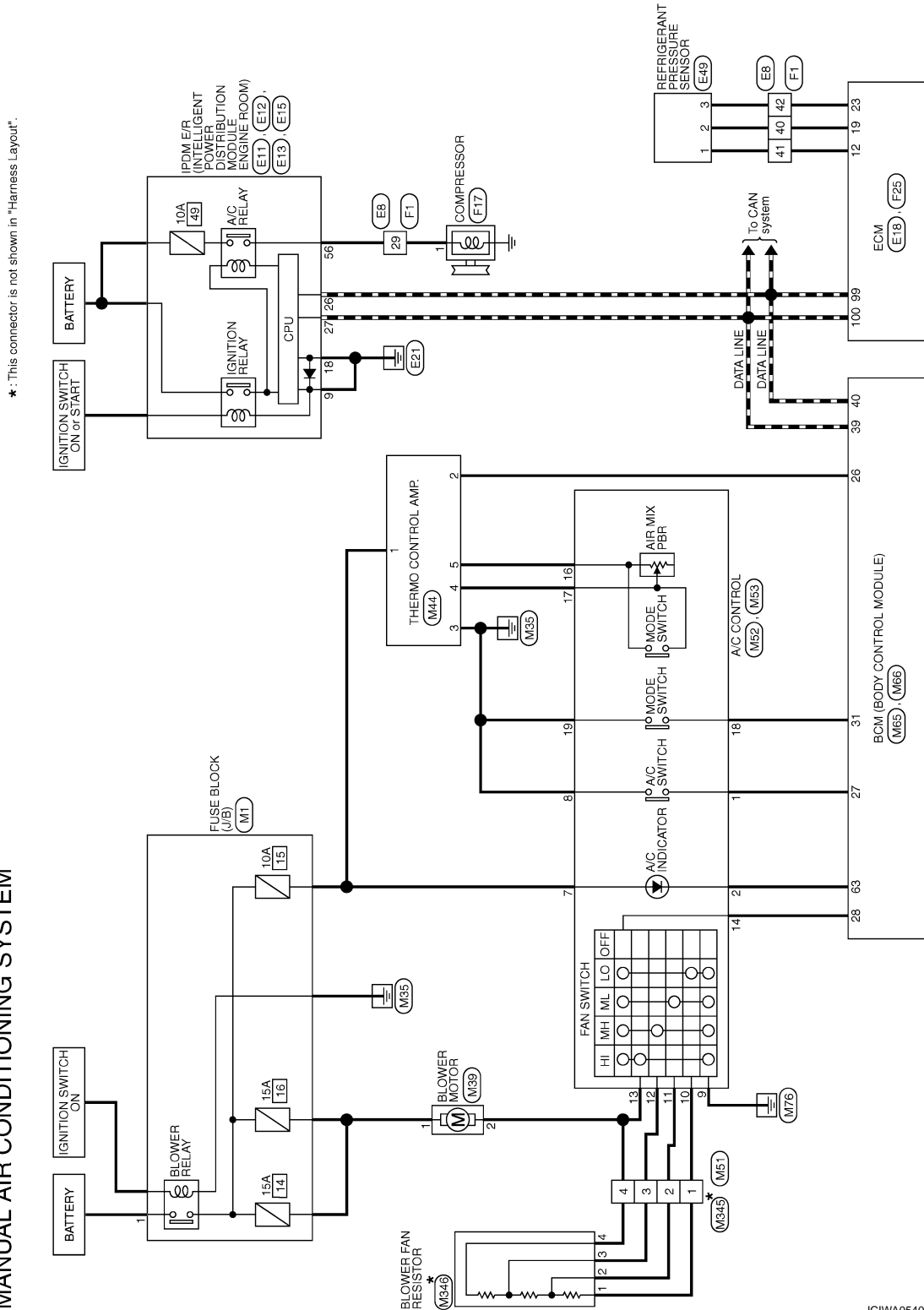

2010/08/30

JCIWA0540GB



# MANUAL AIR CONDITIONING SYSTEM

< WIRING DIAGRAM >

[MANUAL AIR CONDITIONING]

## MANUAL AIR CONDITIONING SYSTEM

Connector No.	E8
Connector Name	WIRE TO WIRE
Connector Type	SAAS3MB-FS10-SLZ2



Terminal No.	Color Of Wire	Signal Name [Specification]
1	P	-
2	L	-
3	G	-
4	LG	-
5	O	-
6	V	-
7	BR	-
8	SB	-
10	R	-
11	O	-
12	G	-
13	O	-
14	Y	-
15	R	-
16	SB	-
17	GR	-
18	W	-
19	L/W	-
20	L/W	-
21	G	-
22	G	-
23	SHIELD	-
24	P	-
25	R	-
26	B	-
27	B	-
28	LG	-
29	SB	-
30	R	-
31	O	-
32	O	-
33	BR	-
34	W	-
37	L	-
39	B	-

40	P	-
41	Y	-
42	L	-
43	BR	-
44	G	-
45	BR	-
46	Y	-
47	SB	-
48	LG	-

Connector No.	E11
Connector Name	POWER IN INTELLIGENT POWER DISTRIBUTION MODULE ENGINE ROOM
Connector Type	MS8FB-LC



Terminal No.	Color Of Wire	Signal Name [Specification]
9	B/Y	-
14	R	-

Connector No.	E19
Connector Name	POWER IN INTELLIGENT POWER DISTRIBUTION MODULE ENGINE ROOM
Connector Type	NS38FBR-CS



Terminal No.	Color Of Wire	Signal Name [Specification]
18	B/Y	-
19	L	-
18	W	- [Without front fog lamp]
20	G	- [With front fog lamp]
20	V	- [Without front fog lamp]
22	G	- [With front fog lamp]

Connector No.	E13
Connector Name	POWER IN INTELLIGENT POWER DISTRIBUTION MODULE ENGINE ROOM
Connector Type	TH12FW-BH

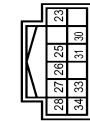

Terminal No.	Color Of Wire	Signal Name [Specification]
23	SB	-
27	SP	-
28	L	-
29	L	-
31	Y	-
33	G	-
34	L	-

Connector No.	E15
Connector Name	POWER IN INTELLIGENT POWER DISTRIBUTION MODULE ENGINE ROOM
Connector Type	RS16FW-CS

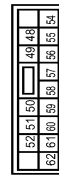

Terminal No.	Color Of Wire	Signal Name [Specification]
48	BR	-
49	Y	-
50	G	-
51	L	-
54	P	-
55	G	-
56	SB	-
57	O	-
58	LG	-

59	V	-
60	SB	-
61	G	-
62	O	-

Connector No.	E18
Connector Name	ECM
Connector Type	RI24FY-R28-R-RH

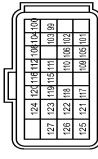

Terminal No.	Color Of Wire	Signal Name [Specification]
99	P	CAN COMMUNICATION LINE (CAN-L)
100	L	CAN COMMUNICATION LINE (CAN-H)
101	V	SENSOR POWER SUPPLY
102	R	ACCELERATOR PEDAL POSITION SENSOR 1
103	BR	PNP SIGNAL
104	R	DATA LINK CONNECTOR
105	GR	SENSOR GROUND
106	Y	POWER SUPPLY FOR ECM (BACKUP)
108	GR	CLUTCH PEDAL POSITION SWITCH
109	O	STOP LAMP SWITCH
110	O	ASCD STEERING SWITCH
111	B	SENSOR GROUND
112	BR	ECM RELAY (SELF SHUT-OFF)
115	SB	STOP LAMP SWITCH
116	G	BRAKE PEDAL POSITION SWITCH
117	Y	FUEL PUMP RELAY
118	O	SENSOR POWER SUPPLY
119	BR	ACCELERATOR PEDAL POSITION SENSOR 2
120	Y	SENSOR GROUND
121	G	POWER SUPPLY FOR ECM
122	GR	THROTTLE CONTROL MOTOR POWER SUPPLY
123	G	ECM GROUND
124	B/Y	ECM GROUND
125	B/Y	ECM GROUND
126	W	HEATED OXYGEN SENSOR 2 HEATER
127	B/Y	ECM GROUND

A  
B  
C  
D  
E  
F  
G  
H  
HAC  
J  
K  
L  
M  
N  
O  
P

# MANUAL AIR CONDITIONING SYSTEM

< WIRING DIAGRAM >

[MANUAL AIR CONDITIONING]

## MANUAL AIR CONDITIONING SYSTEM

Connector No.	E49
Connector Name	REFRIGERANT PRESSURE SENSOR
Connector Type	RK02FB



Terminal No.	Color Of Wire	Signal Name [Specification]
1	Y	—
2	P	—
3	L	—

Connector No.	F1
Connector Name	WIRE TO WIRE
Connector Type	SAAA3FB-RS-ID-SLZ2



Terminal No.	Color Of Wire	Signal Name [Specification]
1	P	—
2	L	—
3	Y	—
4	BG	—
5	LG	—
6	SB	—
7	G	—
8	R	—
9	BR	—
10	PR	—
11	GR	—
12	G	—
13	BG	—
14	L	—
15	BR	—
16	P	—
17	SB	—
18	G	—

19	G	—
20	BR	—
21	C	—
22	BR	—
23	SHIELD	—
24	R	—
25	R	—
26	B	—
27	B	—
28	R	—
29	W	—
30	R	—
31	BG	—
32	LG	—
33	GR	—
34	G	—
37	G	—
38	B	—
40	P	—
41	BR	—
42	W	—
43	L	—
44	G	—
45	BR	—
46	R	—
47	Y	—
48	GR	—

Connector No.	F17
Connector Name	COMPRESSOR
Connector Type	RS01FB



Terminal No.	Color Of Wire	Signal Name [Specification]
1	W	MAGNET CLUTCH POWER SUPPLY

Connector No.	F25
Connector Name	ECM
Connector Type	RHMF8-BZ8-L-RH



Terminal No.	Color Of Wire	Signal Name [Specification]
1	B	ECM GROUND FUEL INJECTOR
2	B	ECM GROUND FUEL INJECTOR
3	G	FUEL INJECTOR NO.4 (HI)
4	Y	FUEL INJECTOR NO.2 (HI)
5	R	FUEL INJECTOR NO.1 (LO)
6	BR	FUEL INJECTOR NO.2 (LO)
7	W	FUEL INJECTOR NO.3 (LO)
8	R	FUEL INJECTOR NO.4 (LO)
9	W	SENSOR GROUND
10	LG	SENSOR GROUND
11	P	SENSOR GROUND
12	BR	SENSOR GROUND
13	G	MASS AIR FLOW SENSOR
14	L	ENGINE COOLANT TEMPERATURE SENSOR
15	Y	WATER TEMPERATURE SENSOR
17	Y	INTAKE AIR PRESSURE SENSOR 1
18	GR	FUEL PAIL PRESSURE SENSOR
19	P	REFRIGERANT PRESSURE SENSOR
21	W	A/F SENSOR 1
22	Y	ENGINE OIL TEMPERATURE SENSOR
23	W	SENSOR POWER SUPPLY
25	B	A/F SENSOR 1
29	W	HEATED OXYGEN SENSOR 2
33	R	SENSOR GROUND
35	SHIELD	SENSOR GROUND
36	W	KNOCK SENSOR
38	B	SHIELD
39	R	SENSOR POWER SUPPLY
41	R	TURBOCHARGER PRESSURE SENSOR
43	G	ENGINE OIL PRESSURE SENSOR
44	SB	SENSOR GROUND

Connector No.	M1
Connector Name	FUSE BLOCK (J/B)
Connector Type	LO1FW-MC



Terminal No.	Color Of Wire	Signal Name [Specification]
1	W	—

Connector No.	M38
Connector Name	BLOWER MOTOR
Connector Type	TM02FW



Terminal No.	Color Of Wire	Signal Name [Specification]
1	Y	—
2	L	—

Connector No.	M44
Connector Name	THERMO CONTROL AMP.
Connector Type	SB0FW



# MANUAL AIR CONDITIONING SYSTEM

< WIRING DIAGRAM >

[MANUAL AIR CONDITIONING]

## MANUAL AIR CONDITIONING SYSTEM

Terminal No.	Color Of Wire	Signal Name [Specification]
1	G	A/C CONTROL
2	BR	—
3	B	—
4	R	—
5	L	—

Connector No.	M51
Connector Name	WIRE TO WIRE
Connector Type	M04FW-LC



Terminal No.	Color Of Wire	Signal Name [Specification]
1	W	—
2	R	—
3	Y	—
4	L	—

Connector No.	M52
Connector Name	A/C CONTROL
Connector Type	G04FW



Terminal No.	Color Of Wire	Signal Name [Specification]
17	B	—
18	G	—
19	B	—

Connector No.	M53
Connector Name	A/C CONTROL
Connector Type	SEA09EB-SH46

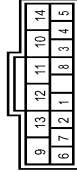

Terminal No.	Color Of Wire	Signal Name [Specification]
1	G	—
2	SB	—
3	W	—
4	R	—
5	V	—
6	GR	—
7	G	—
8	B	—
9	B	—
10	W	—
11	R	—
12	Y	—
13	L	—
14	LG	—

Connector No.	M55
Connector Name	BCM (BODY CONTROL MODULE)
Connector Type	TH40FW-AH

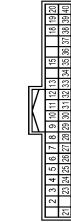

Terminal No.	Color Of Wire	Signal Name [Specification]
2	L	COMBI SW INPUT 5
3	GR	COMBI SW INPUT 4
4	BR	COMBI SW INPUT 3
5	G	COMBI SW INPUT 2
6	W	COMBI SW INPUT 1
7	L	KEY CYL UNLOCK SW

Terminal No.	Color Of Wire	Signal Name [Specification]
8	R	KEY CYL LOCK SW
9	W	REAR WINDOW WASH SW
10	L	REAR WINDOW WASH SW
11	L	REAR WINDOW WASH SW
12	Y	DOOR LK & UNLK SW LOCK
13	BR	DOOR LK & UNLK SW UNLOCK
15	W	—
18	V	RECEIVER GND
19	BR	RECEIVER PWR SPLY
20	G	RECEIVER COMM
21	P	NATS ANT AMP
23	R	SECURITY IND LAMP CONT
24	SB	DONGLE LINK
25	LG	NATS ANT AMP
26	B	THERMO CONT AMP
27	W	BLUETOOTH SW
28	O	HAZARD SW
29	L	—
30	L	BK DOOR OPENER SW
31	G	FR DEFROST SW
32	LG	COMBI SW OUTPUT 5
33	Y	COMBI SW OUTPUT 4
34	V	COMBI SW OUTPUT 3
35	R	COMBI SW OUTPUT 2
36	P	COMBI SW OUTPUT 1
37	GR	KEY SW
38	R	IGN SW ON
39	L	CAN-H
40	P	CAN-L

Connector No.	M66
Connector Name	BCM (BODY CONTROL MODULE)
Connector Type	FEA09FW-FH46-SA

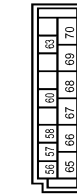

Terminal No.	Color Of Wire	Signal Name [Specification]
56	W	DR DOOR UNLK OUTPUT
57	L	BAT (FUSE)
58	LG	INT ROOM LAMP PWR SPLY
60	BR	INT ROOM LAMP CONT
63	SB	A/C IND OUTPUT

Terminal No.	Color Of Wire	Signal Name [Specification]
65	Y	BAT (FUSE)
66	P	PW PWR SPLY (BAT)
67	J	PW PWR SPLY (IGN)
68	SB	PASS BR DOOR UNLK OUTPUT
69	V	ALL DOOR LOCK OUTPUT
70	B	GND

Connector No.	M245
Connector Name	WIRE TO WIRE
Connector Type	M04MW



Terminal No.	Color Of Wire	Signal Name [Specification]
1	Y	—
2	G	—
3	L	—
4	R	—

Connector No.	M246
Connector Name	BLOWER FAN RESISTOR
Connector Type	M04FBR



Terminal No.	Color Of Wire	Signal Name [Specification]
1	Y	—
2	G	—
3	L	—
4	R	—

A  
B  
C  
D  
E  
F  
G  
H  
HAC  
J  
K  
L  
M  
N  
O  
P

# DIAGNOSIS AND REPAIR WORK FLOW

< BASIC INSPECTION >

[MANUAL AIR CONDITIONING]

## BASIC INSPECTION

### DIAGNOSIS AND REPAIR WORK FLOW

Work Flow

INFOID:000000009754424

OVERALL SEQUENCE

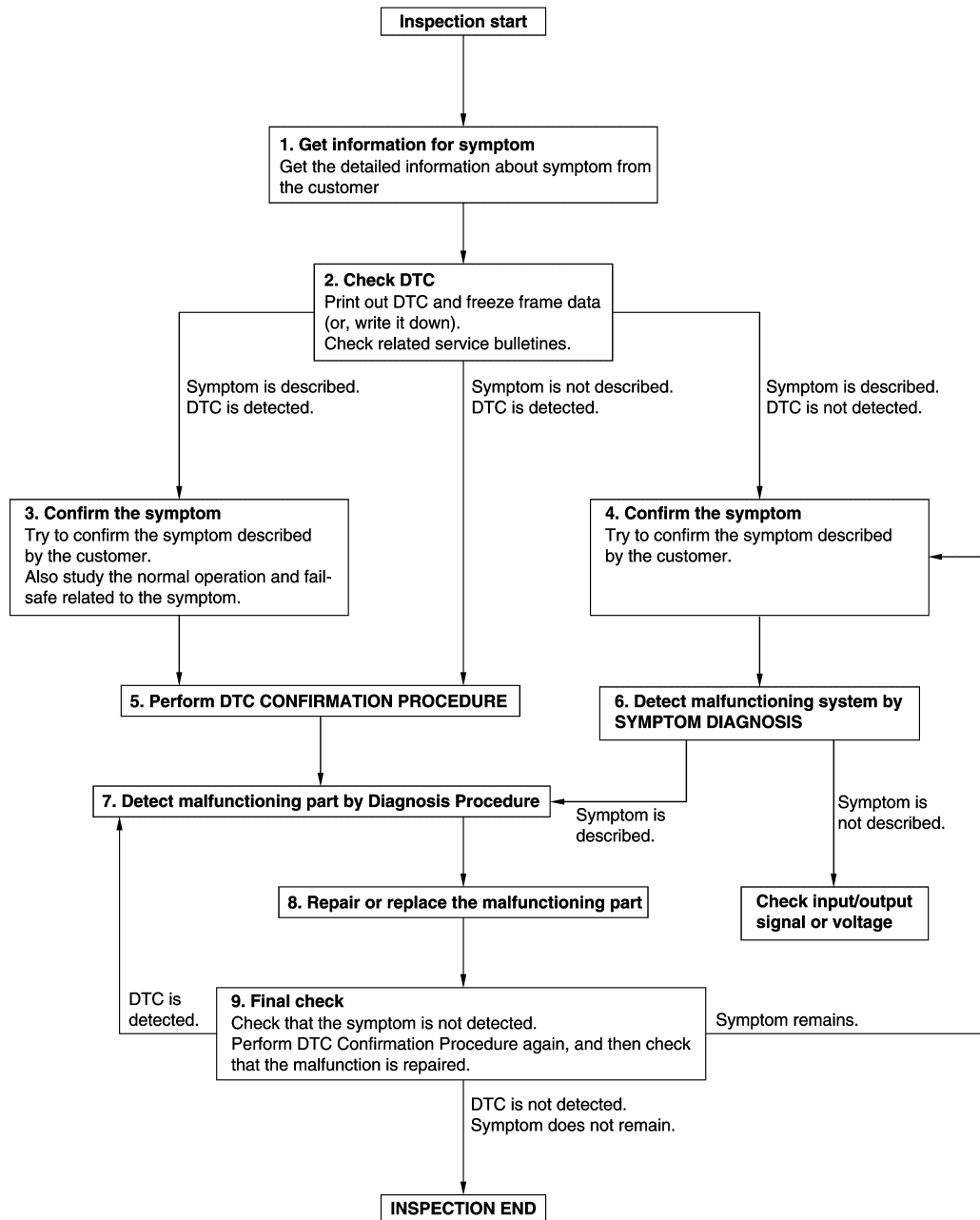

JMKIA8652GB

DETAILED FLOW

Revision: 2013 October

HAC-116

2014 JUKE

# DIAGNOSIS AND REPAIR WORK FLOW

< BASIC INSPECTION >

[MANUAL AIR CONDITIONING]

## 1.GET INFORMATION FOR SYMPTOM

1. Get detailed information from the customer about the symptom (the condition and the environment when the incident/malfunction occurs).
2. Check operation condition of the function that is malfunctioning.

>> GO TO 2.

## 2.CHECK DTC

1. Check DTC.
2. Perform the following procedure if DTC is detected.
  - Record DTC and freeze frame data (Print them out using CONSULT.)
  - Erase DTC.
  - Study the relationship between the cause detected by DTC and the symptom described by the customer.
3. Check related service bulletins for information.

### Are any symptoms described and any DTC detected?

- Symptom is described, DTC is detected>>GO TO 3.
- Symptom is described, DTC is not detected>>GO TO 4.
- Symptom is not described, DTC is detected>>GO TO 5.

## 3.CONFIRM THE SYMPTOM

Try to confirm the symptom described by the customer.  
Also study the normal operation and fail-safe related to the symptom.  
Verify relation between the symptom and the condition when the symptom is detected.

>> GO TO 5.

## 4.CONFIRM THE SYMPTOM

Try to confirm the symptom described by the customer.  
Verify relation between the symptom and the condition when the symptom is detected.

>> GO TO 6.

## 5.PERFORM DTC CONFIRMATION PROCEDURE

Perform DTC CONFIRMATION PROCEDURE for the detected DTC, and then check that DTC is detected again. At this time, always connect CONSULT to the vehicle, and check self diagnostic results in real time. If two or more DTCs are detected, refer to DTC INSPECTION PRIORITY CHART, and determine trouble diagnosis order.

### **NOTE:**

- Freeze frame data is useful if the DTC is not detected.
- Perform Component Function Check if DTC CONFIRMATION PROCEDURE is not included on Service Manual. This simplified check procedure is an effective alternative though DTC cannot be detected during this check.  
If the result of Component Function Check is NG, it is the same as the detection of DTC by DTC CONFIRMATION PROCEDURE.

### Is DTC detected?

- YES >> GO TO 7.
- NO >> Check according to [GI-46. "Intermittent Incident"](#).

## 6.DETECT MALFUNCTIONING SYSTEM BY SYMPTOM DIAGNOSIS

Detect malfunctioning system according to SYMPTOM DIAGNOSIS based on the confirmed symptom in step 4, and determine the trouble diagnosis order based on possible causes and symptom.

### Is the symptom described?

- YES >> GO TO 7.
- NO >> Monitor input data from related sensors or check voltage of related module terminals using CONSULT.

## 7.DETECT MALFUNCTIONING PART BY DIAGNOSIS PROCEDURE

## DIAGNOSIS AND REPAIR WORK FLOW

[MANUAL AIR CONDITIONING]

< BASIC INSPECTION >

---

Inspect according to Diagnosis Procedure of the system.

Is malfunctioning part detected?

YES >> GO TO 8.

NO >> Check according to [GI-46. "Intermittent Incident"](#).

### 8. REPAIR OR REPLACE THE MALFUNCTIONING PART

---

1. Repair or replace the malfunctioning part.
2. Reconnect parts or connectors disconnected during Diagnosis Procedure again after repair and replacement.
3. Check DTC. If DTC is detected, erase it.

>> GO TO 9.

### 9. FINAL CHECK

---

When DTC is detected in step 2, perform DTC CONFIRMATION PROCEDURE again, and then check that the malfunction is repaired securely.

When symptom is described by the customer, refer to confirmed symptom in step 3 or 4, and check that the symptom is not detected.

Is DTC detected and does symptom remain?

YES-1 >> DTC is detected: GO TO 7.

YES-2 >> Symptom remains: GO TO 4.

NO >> Before returning the vehicle to the customer, always erase DTC.

OPERATION INSPECTION

Work Procedure

INFOID:000000009754425

The purpose of the operational check is to check that the individual system operates normally.

Check condition : Engine running at normal operating temperature.

1.CHECK BLOWER MOTOR

- 1. Operate fan control dial.
- 2. Check that fan speed changes. Check operation for all fan speeds.

Is the inspection result normal?

- YES >> GO TO 2.
- NO >> GO TO 8.

2.CHECK DISCHARGE AIR

- 1. Operate fan control dial to set the fan speed to maximum speed.
- 2. Operate MODE dial to each position.
- 3. Check that air outlets change according to each indicated air outlet by placing a hand in front of the air outlets. Refer to [VTL-5, "System Description"](#).

Is the inspection result normal?

- YES >> GO TO 3.
- NO >> GO TO 8.

3.CHECK INTAKE AIR

- 1. Operate intake lever to each position.
- 2. Listen to intake sound and confirm air inlets change.

Is the inspection result normal?

- YES >> GO TO 4.
- NO >> GO TO 8.

4.CHECK COMPRESSOR

- 1. Press A/C switch. The A/C switch indicator is turns ON.
- 2. Check visually and by sound that the compressor operates.
- 3. Press A/C switch again. The A/C switch indicator is turns OFF.
- 4. Check that compressor stops.
- 5. Operate MODE dial to D/F or DEF position. A/C switch indicator is turns ON.
- 6. Check visually and by sound that the compressor operates.

Is the inspection result normal?

- YES >> GO TO 5.
- NO >> GO TO 8.

5.CHECK DISCHARGE AIR TEMPERATURE

- 1. Operate temperature control dial.
- 2. Check that discharge air temperature changes.

Is the inspection result normal?

- YES >> GO TO 6.
- NO >> GO TO 8.

6.CHECK TEMPERATURE DECREASE

- 1. Operate compressor.
- 2. Turn temperature control dial to full cold position.
- 3. Check that cool air blows from the air outlets.

Is the inspection result normal?

- YES >> GO TO 7.
- NO >> GO TO 8.

A  
B  
C  
D  
E  
F  
G  
H  
J  
K  
L  
M  
N  
O  
P

HAC

# OPERATION INSPECTION

< BASIC INSPECTION >

[MANUAL AIR CONDITIONING]

---

## 7. CHECK TEMPERATURE INCREASE

---

1. Turn temperature control dial to full hot position.
2. Check that warm air blows from air outlets.

Is the inspection result normal?

- YES >> INSPECTION END  
NO >> GO TO 8.

## 8. CHECK SELF-DIAGNOSIS WITH CONSULT

---

1. Perform self-diagnosis with CONSULT.
2. Check that any DTC is detected.

Is any DTC detected?

- YES >> Perform trouble diagnosis for the detected DTC.  
NO >> Refer to [HAC-136. "Symptom Table"](#) and perform the appropriate diagnosis.



# DTC/CIRCUIT DIAGNOSIS

## A/C SWITCH

### Component Function Check

INFOID:000000009754426

#### 1.CHECK A/C ON SIGNAL

Ⓜ With CONSULT

1. Turn ignition switch ON.
2. Select "AIR CONDITIONER" of "BCM" using CONSULT.
3. Select "AIR COND SW" in "DATA MONITOR" mode, and check status under the following condition.

Monitor item	Condition	Status
AIR COND SW	A/C switch While pushing	On
	A/C switch While not pushing	Off

Is the inspection result normal?

- YES >> INSPECTION END  
 NO >> Refer to [HAC-121, "Diagnosis Procedure"](#).

### Diagnosis Procedure

INFOID:000000009754427

#### 1.CHECK A/C SWITCH POWER SUPPLY

1. Turn ignition switch OFF.
2. Disconnect A/C control connector.
3. Turn ignition switch ON.
4. Check output waveform between A/C control harness connector and ground with using oscilloscope.

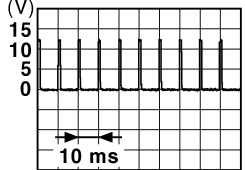
+		-	Output waveform
A/C control			
Connector	Terminal		
M53	1	Ground	 <p style="text-align: right; font-size: small;">JPMIA0012GB</p>

Is the inspection result normal?

- YES >> GO TO 2.  
 NO >> GO TO 3.

#### 2.CHECK A/C SWITCH GROUND CIRCUIT FOR OPEN

1. Turn ignition switch OFF.
2. Check continuity between A/C control harness connector and ground.

A/C control		—	Continuity
Connector	Terminal		
M53	8	Ground	Existed

Is the inspection result normal?

- YES >> Replace A/C control. Refer to [HAC-142, "Removal and Installation"](#).  
 NO >> Repair harness or connector.

#### 3.CHECK A/C SWITCH POWER SUPPLY CIRCUIT FOR OPEN

## A/C SWITCH

[MANUAL AIR CONDITIONING]

### < DTC/CIRCUIT DIAGNOSIS >

1. Turn ignition switch OFF.
2. Disconnect BCM connector.
3. Check continuity between A/C control harness connector and BCM harness connector.

A/C control		BCM		Continuity
Connector	Terminal	Connector	Terminal	
M53	1	M65	27	Existed

Is the inspection result normal?

YES >> GO TO 4.

NO >> Repair harness or connector.

### 4. CHECK A/C SWITCH POWER SUPPLY CIRCUIT FOR SHORT

Check continuity between A/C control harness connector and ground.

A/C control		—	Continuity
Connector	Terminal		
M53	1	Ground	Not existed

Is the inspection result normal?

YES >> Replace BCM. Refer to [BCS-157. "Removal and Installation"](#).

NO >> Repair harness or connector.

# BLOWER FAN ON SIGNAL

< DTC/CIRCUIT DIAGNOSIS >

[MANUAL AIR CONDITIONING]

## BLOWER FAN ON SIGNAL

### Component Function Check

INFOID:000000009754428

#### 1.CHECK BLOWER FAN ON SIGNAL

④ With CONSULT

1. Turn ignition switch ON.
2. Select "AIR CONDITIONER" of "BCM" using CONSULT.
3. Select "FAN ON SIG" in "DATA MONITOR" mode, and check status under the following condition.

Monitor item	Condition		Status
FAN ON SIG	Fan control dial	Except OFF position	On
		OFF position	Off

Is the inspection result normal?

- YES >> INSPECTION END  
 NO >> Refer to [HAC-123, "Diagnosis Procedure"](#).

### Diagnosis Procedure

INFOID:000000009754429

#### 1.CHECK FAN SWITCH POWER SUPPLY SIGNAL

1. Turn ignition switch OFF.
2. Disconnect A/C control harness connector.
3. Turn ignition switch ON.
4. Check output waveform between A/C control and ground with using oscilloscope.

+		-	Output waveform
A/C control			
Connector	Terminal		
M53	14	Ground	

Is the inspection result normal?

- YES >> Replace A/C control. Refer to [HAC-142, "Removal and Installation"](#).  
 NO >> GO TO 2.

#### 2.CHECK BLOWER FAN ON SIGNAL CIRCUIT FOR OPEN

1. Turn ignition switch OFF.
2. Disconnect BCM connector.
3. Check continuity A/C control harness connector and BCM harness connector.

A/C control		BCM		Continuity
Connector	Terminal	Connector	Terminal	
M53	14	M65	28	Existed

Is the inspection result normal?

- YES >> GO TO 3.  
 NO >> Repair harness or connector.

#### 3.CHECK BLOWER FAN ON SIGNAL CIRCUIT FOR SHORT

Check continuity between A/C control harness connector and ground.

# BLOWER FAN ON SIGNAL

< DTC/CIRCUIT DIAGNOSIS >

[MANUAL AIR CONDITIONING]

A/C control		—	Continuity
Connector	Terminal		
M53	14	Ground	Not existed

Is the inspection result normal?

YES >> Replace BCM. Refer to [BCS-157, "Removal and Installation"](#).

NO >> Repair harness or connector.

# THERMO CONTROL AMPLIFIER

< DTC/CIRCUIT DIAGNOSIS >

[MANUAL AIR CONDITIONING]

## THERMO CONTROL AMPLIFIER

### Component Function Check

INFOID:000000009754430

#### 1. CHECK A/C ON SIGNAL

Ⓜ With CONSULT

1. Turn ignition switch ON.
2. Select "AIR CONDITIONER" of "BCM" using CONSULT.
3. Select "THERMO AMP" in "DATA MONITOR" mode, and check status under the following condition.

Monitor item	Condition	Status
THERMO AMP	Ignition switch ON	On
	Ignition switch OFF	Off

Is the inspection result normal?

- YES >> INSPECTION END  
NO >> Refer to [HAC-125, "Diagnosis Procedure"](#).

### Diagnosis Procedure

INFOID:000000009754431

#### 1. CHECK FUSE

1. Turn ignition switch OFF.
2. Check 10A fuse (No. 15, located in fuse block (J/B)).

**NOTE:**

Refer to [PG-62, "Fuse, Connector and Terminal Arrangement"](#).

Is the inspection result normal?

- YES >> GO TO 2.  
NO >> Replace the blown fuse after repairing the affected circuit if a fuse is blown.

#### 2. CHECK THERMO CONTROL AMP. POWER SUPPLY

1. Turn ignition switch OFF.
2. Disconnect thermo control amp. connector.
3. Turn ignition switch ON.
4. Check voltage between thermo control amp. harness connector and ground.

+		-	Voltage
Thermo control amp.			
Connector	Terminal		
M44	1	Ground	Battery voltage

Is the inspection result normal?

- YES >> GO TO 3.  
NO >> Repair harness or connector between thermo control amp. and fuse.

#### 3. CHECK THERMO CONTROL AMP. GROUND CIRCUIT FOR OPEN

1. Turn ignition switch OFF.
2. Check continuity between thermo control amp. harness connector and ground.

Thermo control amp.		—	Continuity
Connector	Terminal		
M44	3	Ground	Existed

Is the inspection result normal?

- YES >> GO TO 4.  
NO >> Repair harness or connector.

A  
B  
C  
D  
E  
F  
G  
H  
J  
K  
L  
M  
N  
O  
P

HAC

# THERMO CONTROL AMPLIFIER

< DTC/CIRCUIT DIAGNOSIS >

[MANUAL AIR CONDITIONING]

## 4. CHECK THERMO CONTROL AMP. SIGNAL

1. Turn ignition switch ON.
2. Check voltage between thermo control amp. harness connector and ground.

+		-	Voltage (Approx.)
Thermo control amp.			
Connector	Terminal		
M44	2	Ground	12 V

Is the inspection result normal?

- YES >> Replace thermo control amp. Refer to [HAC-143. "Removal and Installation"](#).  
NO >> GO TO 5.

## 5. CHECK THERMO CONTROL AMP. SIGNAL CIRCUIT FOR OPEN

1. Turn ignition switch OFF.
2. Disconnect BCM connector.
3. Check continuity between thermo control amp. harness connector and BCM harness connector.

Thermo control amp.		BCM		Continuity
Connector	Terminal	Connector	Terminal	
M44	2	M65	26	Existed

Is the inspection result normal?

- YES >> Replace BCM. Refer to [BCS-157. "Removal and Installation"](#).  
NO >> Repair harness or connector.

# DEFROSTER POSITION SIGNAL

< DTC/CIRCUIT DIAGNOSIS >

[MANUAL AIR CONDITIONING]

## DEFROSTER POSITION SIGNAL

### Component Function Check

INFOID:000000009754432

#### 1. CHECK DEFROSTER POSITION SIGNAL

Ⓜ With CONSULT

- Turn ignition switch ON.
- Select "AIR CONDITIONER" of "BCM" using CONSULT.
- Select "FR DEF SW" in "DATA MONITOR" mode, and check status under the following condition.

Monitor item	Condition		Status
FR DEF SW	MODE dial	D/F or DEF	On
		VENT, B/L or FOOT	Off

Is the inspection result normal?

- YES >> INSPECTION END  
 NO >> Refer to [HAC-127, "Diagnosis Procedure"](#).

### Diagnosis Procedure

INFOID:000000009754433

#### 1. CHECK MODE SWITCH POWER SUPPLY

- Turn ignition switch OFF.
- Disconnect A/C control connector.
- Turn ignition switch ON.
- Check output waveform between A/C control harness connector and ground with using oscilloscope.

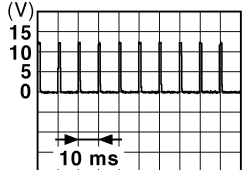
+		-	Output waveform
A/C control			
Connector	Terminal		
M52	18	Ground	 <p>JPMA0012GB</p>

Is the inspection result normal?

- YES >> GO TO 2.  
 NO >> GO TO 3.

#### 2. CHECK MODE SWITCH GROUND CIRCUIT FOR OPEN

- Turn ignition switch OFF.
- Check continuity between A/C control harness connector and ground.

A/C control		—	Continuity
Connector	Terminal		
M52	19	Ground	Existed

Is the inspection result normal?

- YES >> Replace A/C control. Refer to [HAC-142, "Removal and Installation"](#).  
 NO >> Repair harness or connector.

#### 3. CHECK MODE SWITCH POWER SUPPLY CIRCUIT FOR OPEN

- Turn ignition switch OFF.
- Disconnect BCM connector.

## DEFROSTER POSITION SIGNAL

< DTC/CIRCUIT DIAGNOSIS >

[MANUAL AIR CONDITIONING]

3. Check continuity between A/C control harness connector and BCM harness connector.

A/C control		BCM		Continuity
Connector	Terminal	Connector	Terminal	
M52	18	M65	31	Existed

Is the inspection result normal?

YES >> GO TO 4.

NO >> Repair harness or connector.

### 4. CHECK MODE SWITCH POWER SUPPLY CIRCUIT FOR SHORT

Check continuity between A/C control harness connector and ground.

A/C control		—	Continuity
Connector	Terminal		
M52	18	Ground	Not existed

Is the inspection result normal?

YES >> Replace BCM. Refer to [BCS-157, "Removal and Installation"](#).

NO >> Repair harness or connector.



A/C INDICATOR

Diagnosis Procedure

INFOID:000000009754434

1.CHECK SYMPTOM

Check symptom.

- A/C indicator does not turn ON>>GO TO 2.
- A/C indicator does not turn OFF>>GO TO 6.

2.CHECK FUSE

1. Turn ignition switch OFF.
2. Check 10A fuse (No. 15, located in fuse block (J/B)).

**NOTE:**

Refer to [PG-62. "Fuse, Connector and Terminal Arrangement"](#).

Is the inspection result normal?

- YES >> GO TO 3.
- NO >> Replace the blown fuse after repairing the affected circuit if a fuse is blown.

3.CHECK A/C INDICATOR POWER SUPPLY

1. Turn ignition switch ON.
2. Check voltage between A/C control harness connector and ground.

+		-	Voltage
A/C control			
Connector	Terminal		
M53	7	Ground	Battery voltage

Is the inspection result normal?

- YES >> GO TO 4.
- NO >> Repair harness or connector between A/C control and fuse.

4.CHECK A/C INDICATOR CIRCUIT

Check voltage between A/C control harness connector and ground.

+		-	Voltage (Approx.)
A/C control			
Connector	Terminal		
M53	2	Ground	12 V

Is the inspection result normal?

- YES >> GO TO 5.
- NO >> Replace A/C control. Refer to [HAC-142. "Removal and Installation"](#).

5.CHECK A/C INDICATOR CIRCUIT FOR OPEN

1. Turn ignition switch OFF.
2. Disconnect A/C control connector and BCM connector.
3. Check continuity between A/C control harness connector and BCM harness connector.

A/C control		BCM		Continuity
Connector	Terminal	Connector	Terminal	
M53	2	M66	63	Existed

Is the inspection result normal?

- YES >> Replace BCM. Refer to [BCS-157. "Removal and Installation"](#).
- NO >> Repair harness or connector.

A  
B  
C  
D  
E  
F  
G  
H  
J  
K  
L  
M  
N  
O  
P

HAC

# A/C INDICATOR

< DTC/CIRCUIT DIAGNOSIS >

[MANUAL AIR CONDITIONING]

## 6. CHECK A/C INDICATOR CIRCUIT FOR SHORT

1. Turn ignition switch OFF.
2. Disconnect A/C control connector and BCM connector.
3. Check continuity between A/C control harness connector and ground.

A/C control		—	Continuity
Connector	Terminal		
M53	2	Ground	Not existed

Is the inspection result normal?

- YES >> Replace BCM. Refer to [BCS-157, "Removal and Installation"](#).  
NO >> Repair harness or connector.

## BLOWER MOTOR

### Diagnosis Procedure

INFOID:000000009754435

#### 1. CHECK SYMPTOM

Check symptom (A or B).

Symptom	
A	Blower motor does not operate at any dial position
B	Blower motor does not operate at any dial position other than 4, or operation speed is not normal.

Which symptom is detected?

- A >> GO TO 2.
- B >> GO TO 7.

#### 2. CHECK FUSE

1. Turn ignition switch OFF.
2. Check 15A fuses (Nos. 14 and 16, located in fuse block (J/B]).

**NOTE:**

Refer to [PG-62. "Fuse, Connector and Terminal Arrangement"](#).

Is the inspection result normal?

- YES >> GO TO 3.
- NO >> Replace the blown fuse after repairing the affected circuit if a fuse is blown.

#### 3. CHECK BLOWER MOTOR POWER SUPPLY

1. Disconnect blower motor connector.
2. Turn ignition switch ON.
3. Check voltage between blower motor harness connector and ground.

+		-	Voltage
Blower motor			
Connector	Terminal		
M39	1	Ground	Battery voltage

Is the inspection result normal?

- YES >> GO TO 5.
- NO >> GO TO 4.

#### 4. CHECK BLOWER RELAY

1. Turn ignition switch OFF.
2. Check blower relay. Refer to [HAC-133. "Component Inspection \(Blower Relay\)"](#).

Is the inspection result normal?

- YES >> Repair harness or connector between blower motor and fuse.
- NO >> Replace blower relay.

#### 5. CHECK FAN SWITCH GROUND CIRCUIT FOR OPEN

1. Turn ignition switch OFF.
2. Disconnect A/C control connector.
3. Check continuity between A/C control harness connector and ground.

A/C control		—	Continuity
Connector	Terminal		
M53	9	Ground	Existed

Is the inspection result normal?

# BLOWER MOTOR

[MANUAL AIR CONDITIONING]

< DTC/CIRCUIT DIAGNOSIS >

- YES >> GO TO 6.  
NO >> Repair harness or connector.

## 6. CHECK FAN SWITCH 4 POSITION CIRCUIT FOR OPEN

Check continuity between A/C control harness connector and blower motor harness connector.

A/C control		Blower motor		Continuity
Connector	Terminal	Connector	Terminal	
M53	13	M39	2	Existed

Is the inspection result normal?

- YES >> GO TO 10.  
NO >> Repair the harness or connector.

## 7. CHECK BLOWER FAN RESISTOR POWER SUPPLY

1. Turn ignition switch OFF.
2. Disconnect blower fan resistor connector.
3. Turn ignition switch ON.
4. Check voltage between blower fan resistor harness connector and ground.

+		-	Voltage
Blower fan resistor			
Connector	Terminal		
M346	4	Ground	Battery voltage

Is the inspection result normal?

- YES >> GO TO 8.  
NO >> Repair harness or connector between blower fan resistor and blower motor.

## 8. CHECK BLOWER FAN RESISTOR

1. Turn the ignition switch OFF.
2. Check blower fan resistor. Refer to [HAC-133. "Component Inspection \(Blower Fan Resistor\)".](#)

Is the inspection result normal?

- YES >> GO TO 9.  
NO >> Replace blower fan resistor. Refer to [HAC-145. "Removal and Installation".](#)

## 9. CHECK FAN SWITCH 1, 2, 3 POSITION CIRCUIT FOR OPEN

Check continuity between A/C control harness connector and blower fan resistor.

A/C control		Blower fan resistor		Continuity
Connector	Terminal	Connector	Terminal	
M53	10	M346	1	Existed
	11		2	
	12		3	

Is the inspection result normal?

- YES >> GO TO 10.  
NO >> Repair harness or connector.

## 10. CHECK FAN SWITCH

Check fan switch. Refer to [HAC-133. "Component Inspection \(Fan Switch\)".](#)

Is the inspection result normal?

- YES >> Replace blower motor. Refer to [VTL-14. "Removal and Installation".](#)  
NO >> Replace A/C control. Refer to [HAC-142. "Removal and Installation".](#)

# BLOWER MOTOR

< DTC/CIRCUIT DIAGNOSIS >

[MANUAL AIR CONDITIONING]

## Component Inspection (Blower Motor)

INFOID:000000009754436

### 1.CHECK BLOWER MOTOR

1. Remove blower motor. Refer to [VTL-14, "Removal and Installation"](#).
2. Check that there is not any mixing foreign object in the blower motor.

Is the inspection result normal?

YES >> GO TO 2.

NO >> Replace blower motor. Refer to [VTL-14, "Removal and Installation"](#).

### 2.CHECK BLOWER MOTOR

Check that there is not breakage or damage in the blower motor.

Is the inspection result normal?

YES >> GO TO 3.

NO >> Replace blower motor. Refer to [VTL-14, "Removal and Installation"](#).

### 3.CHECK BLOWER MOTOR

Check that blower motor turns smoothly.

Is the inspection result normal?

YES >> INSPECTION END

NO >> Replace blower motor. Refer to [VTL-14, "Removal and Installation"](#).

## Component Inspection (Blower Relay)

INFOID:000000009754437

### 1.CHECK BLOWER RELAY

1. Remove blower relay. Refer to [PG-63, "Fuse and Fusible Link Arrangement"](#).
2. Check continuity between blower relay terminal 3 and 5 when the voltage is supplied between terminal 1 and 2.

Terminal		Voltage	Continuity
3	5	ON	Existed
		OFF	Not existed

Is the inspection result normal?

YES >> INSPECTION END

NO >> Replace blower relay.

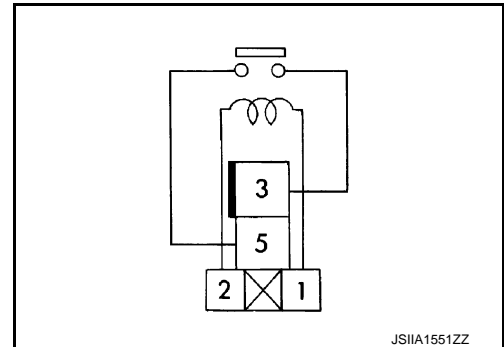

## Component Inspection (Blower Fan Resistor)

INFOID:000000009754438

### 1.CHECK BLOWER FAN RESISTOR

1. Disconnect blower fan resistor connector.
2. Check resistance between blower fan resistor terminals. Refer to applicable table for the normal value.

Terminal		Resistance: $\Omega$ (Approx.)
4	3	0.43
	2	1.03
	1	3

Is the inspection result normal?

YES >> INSPECTION END

NO >> Replace blower fan resistor. Refer to [HAC-145, "Removal and Installation"](#).

## Component Inspection (Fan Switch)

INFOID:000000009754439

### 1.CHECK FAN SWITCH

# BLOWER MOTOR

< DTC/CIRCUIT DIAGNOSIS >

[MANUAL AIR CONDITIONING]

Check continuity between A/C control terminals.

Terminal		Condition	Continuity
		Fan control dial position	
9	10	1st	Existed
	11	2nd	
	12	3rd	
	13	4th	

Is the inspection result normal?

YES >> INSPECTION END

NO >> Replace A/C control. Refer to [HAC-142, "Removal and Installation"](#).

## MAGNET CLUTCH

### Component Function Check

INFOID:000000009754440

#### 1. CHECK MAGNET CLUTCH OPERATION

Perform auto active test of IPDM E/R. Refer to [PCS-43, "Diagnosis Description"](#).

Does it operate normally?

- YES >> INSPECTION END
- NO >> Refer to [HAC-135, "Diagnosis Procedure"](#).

### Diagnosis Procedure

INFOID:000000009754441

#### 1. CHECK FUSE

1. Turn ignition switch OFF.
2. Check 10A fuse (No. 49, located in IPDM E/R).

**NOTE:**

Refer to [PG-64, "Fuse, Connector and Terminal Arrangement"](#).

Is the inspection result normal?

- YES >> GO TO 2.
- NO >> Replace the blown fuse after repairing the affected circuit if a fuse is blown.

#### 2. CHECK MAGNET CLUTCH

1. Disconnect compressor connector.
2. Directly apply battery voltage to the magnet clutch. Check for operation visually and by sound.

Does it operate normally?

- YES >> GO TO 3.
- NO >> Replace magnet clutch. Refer to [HA-30, "MAGNET CLUTCH : Removal and Installation of Compressor Clutch"](#).

#### 3. CHECK MAGNET CLUTCH POWER SUPPLY CIRCUIT FOR OPEN

1. Disconnect IPDM E/R connector.
2. Check continuity between IPDM E/R harness connector and compressor harness connector.

IPDM E/R		Compressor		Continuity
Connector	Terminal	Connector	Terminal	
E15	56	F17	1	Existed

Is the inspection result normal?

- YES >> Replace IPDM E/R. Refer to [PCS-62, "Removal and Installation"](#).
- NO >> Repair harness or connector.

A  
B  
C  
D  
E  
F  
G  
H  
J  
K  
L  
M  
N  
O  
P

HAC

# MANUAL AIR CONDITIONING SYSTEM

< SYMPTOM DIAGNOSIS >

[MANUAL AIR CONDITIONING]

## SYMPTOM DIAGNOSIS

### MANUAL AIR CONDITIONING SYSTEM

#### Symptom Table

INFOID:000000009754442

**NOTE:**

Perform self-diagnosis with CONSULT before performing the symptom diagnosis. If any malfunction result or DTC is detected, perform the corresponding diagnosis.

Symptom	Corresponding malfunction part	Check item/Reference
<ul style="list-style-type: none"> <li>Blower motor does not operate at any dial position.</li> <li>Blower motor does not operate at any dial position other than 4, or operation speed is not normal.</li> </ul>	<ul style="list-style-type: none"> <li>Blower motor</li> <li>Blower motor power supply circuit</li> <li>The circuit between blower motor and fan switch</li> <li>The circuit between blower motor and blower fan resistor</li> <li>The circuit between blower fan resistor and fan switch (A/C control)</li> <li>Blower fan resistor</li> <li>Fan switch (A/C control)</li> </ul>	<a href="#">HAC-131, "Diagnosis Procedure"</a>
<ul style="list-style-type: none"> <li>A/C indicator does not turn ON. (Compressor operates)</li> <li>A/C indicator does not turn OFF. (Compressor stops)</li> </ul>	<ul style="list-style-type: none"> <li>A/C indicator (A/C control) power supply circuit</li> <li>The circuit between A/C indicator (A/C control) and BCM</li> <li>A/C indicator (A/C control)</li> <li>BCM</li> </ul>	<a href="#">HAC-129, "Diagnosis Procedure"</a>
Compressor does not operate. (Blower motor operates)	<ul style="list-style-type: none"> <li>Magnet clutch</li> <li>The circuit between magnet clutch and IPDM E/R</li> <li>IPDM E/R (A/C relay)</li> <li>The circuit between ECM and refrigerant pressure sensor</li> <li>Refrigerant pressure sensor</li> <li>A/C ON signal circuit</li> <li>Blower fan ON signal circuit</li> <li>CAN communication line</li> <li>A/C control</li> <li>Thermo control amp.</li> <li>BCM</li> </ul>	<a href="#">HAC-140, "Diagnosis Procedure"</a>
When the MODE dial is set to D/F or DEF, there is the compressor does not operate. (A/C switch is normal)	<ul style="list-style-type: none"> <li>Defroster position signal circuit</li> <li>A/C control</li> <li>BCM</li> </ul>	<a href="#">HAC-127, "Component Function Check"</a>
<ul style="list-style-type: none"> <li>Insufficient cooling</li> <li>No cool air comes out. (Air flow volume is normal.)</li> </ul>	<ul style="list-style-type: none"> <li>Magnet clutch control system</li> <li>Drive belt slipping</li> <li>Cooler cycle</li> <li>Air leakage from each duct</li> </ul>	<a href="#">HAC-138, "Diagnosis Procedure"</a>
<ul style="list-style-type: none"> <li>Insufficient heating</li> <li>No warm air comes out. (Air flow volume is normal.)</li> </ul>	<ul style="list-style-type: none"> <li>Engine cooling system</li> <li>Heater hose</li> <li>Heater core</li> <li>Air leakage from each duct</li> </ul>	<a href="#">HAC-139, "Diagnosis Procedure"</a>
Noise is heard when the A/C system operates.	During compressor operation	Cooler cycle <a href="#">HA-27, "Symptom Table"</a>
	During blower motor operation	<ul style="list-style-type: none"> <li>Mixing any foreign object in blower motor</li> <li>Blower motor fan breakage</li> <li>Blower motor rotation inferiority</li> </ul> <a href="#">HAC-133, "Component Inspection (Blower Motor)"</a>
Discharge air temperature does not change.	<ul style="list-style-type: none"> <li>A/C control</li> <li>Air mix door cable</li> <li>Air mix door</li> </ul>	Check the air mix door installation and door operation



# MANUAL AIR CONDITIONING SYSTEM

< SYMPTOM DIAGNOSIS >

[MANUAL AIR CONDITIONING]

Symptom	Corresponding malfunction part	Check item/Reference
Air outlet does not change.	<ul style="list-style-type: none"> <li>• A/C control</li> <li>• Mode door cable</li> <li>• Mode door</li> </ul>	Check the mode door installation and door operation
Air inlet does not change.	<ul style="list-style-type: none"> <li>• A/C control</li> <li>• Intake door cable</li> <li>• Intake door</li> </ul>	Check the intake door installation and door operation

A  
B  
C  
D  
E  
F  
G  
H  
J  
K  
L  
M  
N  
O  
P

HAC

**INSUFFICIENT COOLING****Description**

INFOID:000000009754443

## Symptom

- Insufficient cooling
- No cool air comes out. (Air flow volume is normal.)

**Diagnosis Procedure**

INFOID:000000009754444

**NOTE:**

Perform self-diagnosis with CONSULT before performing symptom diagnosis. If any malfunction result or DTC is detected, perform the corresponding diagnosis.

**1.CHECK MAGNET CLUTCH OPERATION**

1. Turn ignition switch ON.
2. Turn fan control dial ON.
3. Press A/C switch.
4. Check that A/C indicator turns ON. Check visually and by sound that compressor operates.
5. Press A/C switch again.
6. Check that A/C indicator turns OFF. Check that compressor stops.

Is the inspection result normal?

- YES >> GO TO 2.  
 NO >> Perform the diagnosis of "COMPRESSOR DOES NOT OPERATE" in "SYMPTOM DIAGNOSIS".  
 Refer to [HAC-140. "Diagnosis Procedure"](#).

**2.CHECK DRIVE BELT**

Check tension of the drive belt. Refer to [EM-19. "Inspection"](#).

Is the inspection result normal?

- YES >> GO TO 3.  
 NO >> Adjust or replace drive belt depending on the inspection results.

**3.CHECK REFRIGERANT CYCLE PRESSURE**

Connect the recovery/recycling recharging equipment to the vehicle and perform the pressure inspection with the gauge. Refer to [HA-25. "Symptom Table"](#).

Is the inspection result normal?

- YES >> GO TO 4.  
 NO >> Repair or replace parts depending on the inspection results.

**4.CHECK AIR LEAKAGE FROM EACH DUCT**

Check duct and nozzle, etc. of the air conditioner system for leakage.

Is the inspection result normal?

- YES >> Check air mix door cable installation and air mix door operation.  
 NO >> Repair or replace parts depending on the inspection results.

## INSUFFICIENT HEATING

### Description

INFOID:000000009754445

#### Symptom

- Insufficient heating
- No warm air comes out. (Air flow volume is normal.)

### Diagnosis Procedure

INFOID:000000009754446

#### NOTE:

Perform self-diagnosis with CONSULT before performing symptom diagnosis. If any malfunction result or DTC is detected, perform the corresponding diagnosis.

#### 1.CHECK COOLING SYSTEM

1. Check engine coolant level and check for leakage. Refer to [CO-8, "Inspection"](#).
2. Check radiator cap. Refer to [CO-12, "RADIATOR CAP : Inspection"](#).
3. Check water flow sounds of the engine coolant. Refer to [CO-9, "Refilling"](#).

#### Is the inspection result normal?

YES >> GO TO 2.

NO >> Refill engine coolant and repair or replace parts depending on the inspection results.

#### 2.CHECK HEATER HOSE

Check installation of heater hose by visually or touching.

#### Is the inspection result normal?

YES >> GO TO 3.

NO >> Repair or replace parts depending on the inspection results.

#### 3.CHECK HEATER CORE

1. Check temperature of inlet hose and outlet hose of heater core.
2. Check that inlet side of heater core is hot and the outlet side is slightly lower than/almost equal to the inlet side.

#### **CAUTION:**

**Always perform the temperature inspection in a short period of time because the engine coolant temperature is very hot.**

#### Is the inspection result normal?

YES >> GO TO 4.

NO >> Replace heater core. Refer to [HA-46, "HEATER CORE : Removal and Installation"](#).

#### 4.CHECK AIR LEAKAGE FROM EACH DUCT

Check duct and nozzle, etc. of air conditioning system for air leakage.

#### Is the inspection result normal?

YES >> Check air mix door cable installation and air mix door operation.

NO >> Repair or replace parts depending on the inspection results.

A  
B  
C  
D  
E  
F  
G  
H  
HAC  
J  
K  
L  
M  
N  
O  
P

# COMPRESSOR DOES NOT OPERATE

< SYMPTOM DIAGNOSIS >

[MANUAL AIR CONDITIONING]

## COMPRESSOR DOES NOT OPERATE

### Description

INFOID:000000009754447

### SYMPTOM

Compressor does not operate.

### Diagnosis Procedure

INFOID:000000009754448

#### NOTE:

- Perform self-diagnosis with CONSULT before performing symptom diagnosis. If any malfunction result or DTC is detected, perform the corresponding diagnosis.
- Check that refrigerant is enclosed in cooler cycle normally. If the refrigerant amount is shortage from proper amount, perform the inspection of refrigerant leakage

### 1.CHECK A/C INDICATOR

1. Turn ignition switch ON.
2. Operate blower motor.
3. Check that A/C indicator is turned ON/OFF when operating A/C switch.

Is the inspection result normal?

YES >> GO TO 2.

NO >> GO TO 5.

### 2.CHECK MAGNET CLUTCH OPERATION

Check magnet clutch. Refer to [HAC-135, "Component Function Check"](#).

Does it operate normally?

YES >> GO TO 3.

NO >> Repair or replace malfunctioning parts.

### 3.CHECK REFRIGERANT PRESSURE SENSOR

Check refrigerant pressure sensor. Refer to [EC-539, "Component Function Check"](#).

Is the inspection result normal?

YES >> GO TO 4.

NO >> Repair or replace malfunctioning parts.

### 4.CHECK BCM OUTPUT SIGNAL

 With CONSULT

1. Select "DATA MONITOR" mode of "ECM" using CONSULT.
2. Select "AIR COND SIG" and "HEATER FAN SW", and check status under the following conditions.

Monitor item	Condition		Status
AIR COND SIG	A/C switch	OFF (A/C indicator: OFF)	Off
		ON (A/C indicator: ON)	On
HEATER FAN SW	Blower motor	OFF	Off
		ON	On

Is the inspection result normal?

YES >> Replace IPDM E/R. Refer to [PCS-62, "Removal and Installation"](#).

NO >> Replace BCM. Refer to [BCS-157, "Removal and Installation"](#).

### 5.CHECK A/C SWITCH

Check A/C switch. Refer to [HAC-121, "Component Function Check"](#).

Is the inspection result normal?

YES >> GO TO 6.

NO >> Repair or replace the malfunctioning parts.

### 6.CHECK BLOWER FAN ON SIGNAL

# COMPRESSOR DOES NOT OPERATE

[MANUAL AIR CONDITIONING]

< SYMPTOM DIAGNOSIS >

Check blower fan ON signal. Refer to [HAC-123, "Component Function Check"](#).

Is the inspection result normal?

YES >> GO TO 7.

NO >> Repair or replace the malfunctioning parts

**7**.CHECK THERMO CONTROL AMP.

Check thermo control amp. Refer to [HAC-125, "Component Function Check"](#).

Is the inspection result normal?

YES >> Replace BCM. Refer to [BCS-157, "Removal and Installation"](#).

NO >> Repair or replace the malfunctioning parts

A  
B  
C  
D  
E  
F  
G  
H  
J  
K  
L  
M  
N  
O  
P

HAC

## REMOVAL AND INSTALLATION

### A/C CONTROL

#### Exploded View

INFOID:000000009754449

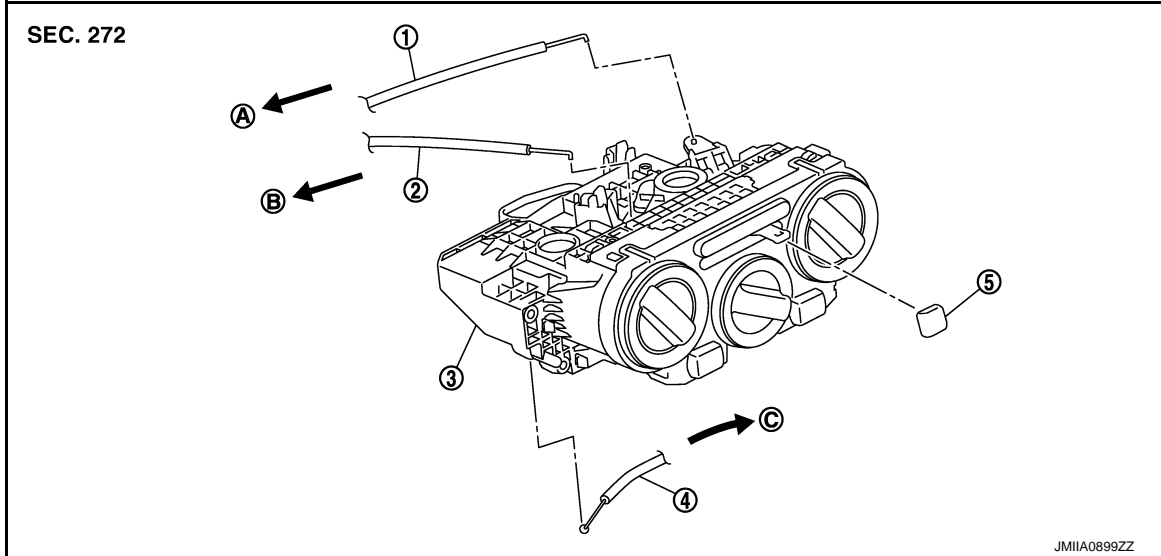

- |                         |                           |                      |
|-------------------------|---------------------------|----------------------|
| 1. Air mix door cable   | 2. Intake door cable      | 3. A/C control       |
| 4. Mode door cable      | 5. Intake door lever knob |                      |
| A. To air mix door link | B. To intake door link    | C. To mode door link |

### Removal and Installation

INFOID:000000009754450

#### REMOVAL

1. Remove A/C finisher. Refer to [IP-13, "Removal and Installation"](#).
2. Remove fixing screws (A) and fixing pawls, and then remove A/C control.

 : Pawl

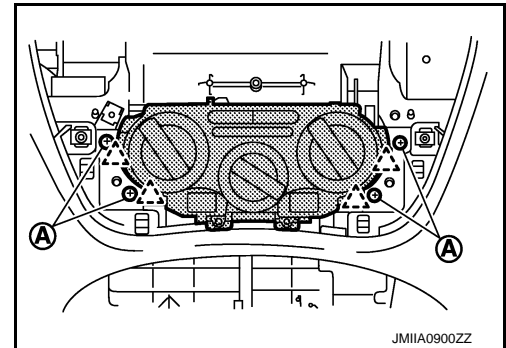

3. Disconnect door cable and harness connector from A/C control.

#### INSTALLATION

Install in the reverse order of removal.

THERMO CONTROL AMPLIFIER

Removal and Installation

INFOID:000000009754451

REMOVAL

1. Remove evaporator. Refer to [HA-46. "EVAPORATOR : Removal and Installation"](#).
2. Disconnect thermo control amp. from evaporator.

INSTALLATION

Note the following items, and then install in the reverse order of removal.

**CAUTION:**

- **Replace O-ring with new one. Then apply compressor oil to them when installing.**
- **When install the thermo control amp., set the same position before replacement.**
- **When remove the thermo control amp., never turn the bracket which is equipped the top of the thermo control amp.**
- **Check for the leakages when recharging refrigerant. Refer to [HA-17. "Leak Test"](#).**

A  
B  
C  
D  
E  
F  
G  
H  
J  
K  
L  
M  
N  
O  
P

HAC

# REFRIGERANT PRESSURE SENSOR

< REMOVAL AND INSTALLATION >

[MANUAL AIR CONDITIONING]

---

## REFRIGERANT PRESSURE SENSOR

### Exploded View

INFOID:000000009754452

Refer to [HA-36. "Exploded View"](#).

### Removal and Installation

INFOID:000000009754453

#### REMOVAL

Refer to [HA-38. "REFRIGERANT PRESSURE SENSOR : Removal and Installation"](#).

#### INSTALLATION

Install in the reverse order of removal.



# BLOWER FAN RESISTOR

< REMOVAL AND INSTALLATION >

[MANUAL AIR CONDITIONING]

## BLOWER FAN RESISTOR

Exploded View

INFOID:000000009754454

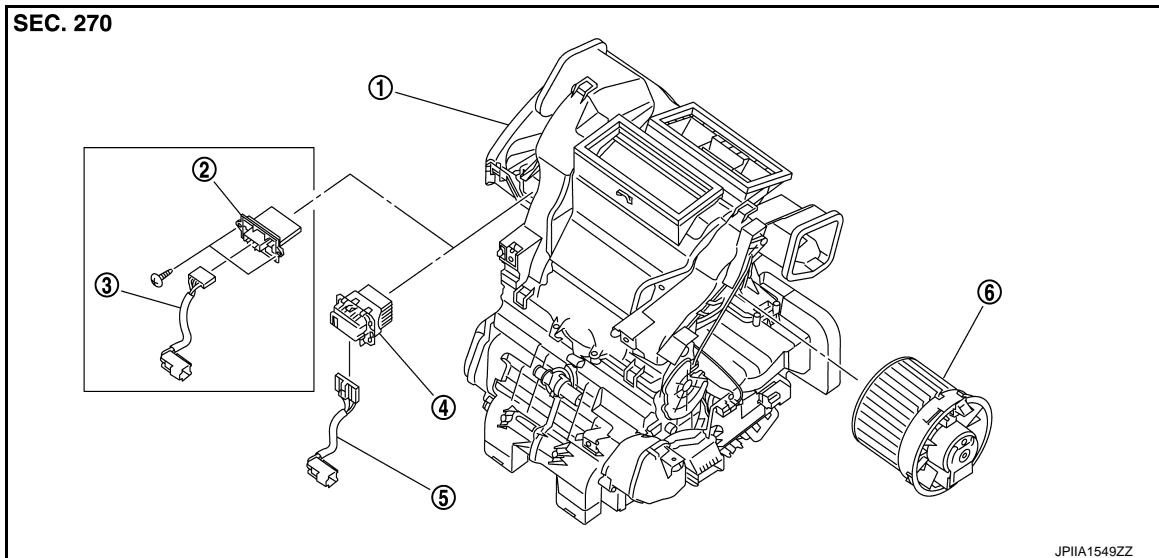

- |                                   |                                      |                              |
|-----------------------------------|--------------------------------------|------------------------------|
| 1. A/C unit assembly              | 2. Blower fan resistor* <sup>1</sup> | 3. Sub harness* <sup>1</sup> |
| 4. Power transistor* <sup>2</sup> | 5. Sub harness* <sup>2</sup>         | 6. Blower motor              |

- \*1: Manual air conditioning
- \*2: Automatic air conditioning

## Removal and Installation

INFOID:000000009754455

### REMOVAL

1. Remove instrument panel assembly. Refer to [IP-13, "Removal and Installation"](#).
2. Disconnect blower fan resistor harness connector.
3. Remove fixing screws, and then remove blower fan resistor from A/C unit assembly.

### INSTALLATION

Install in the reverse order of removal.

A  
B  
C  
D  
E  
F  
G  
H  
J  
K  
L  
M  
N  
O  
P

HAC

# DOOR CABLE

< REMOVAL AND INSTALLATION >

[MANUAL AIR CONDITIONING]

## DOOR CABLE

Exploded View

INFOID:00000009754456

LEFT SIDE

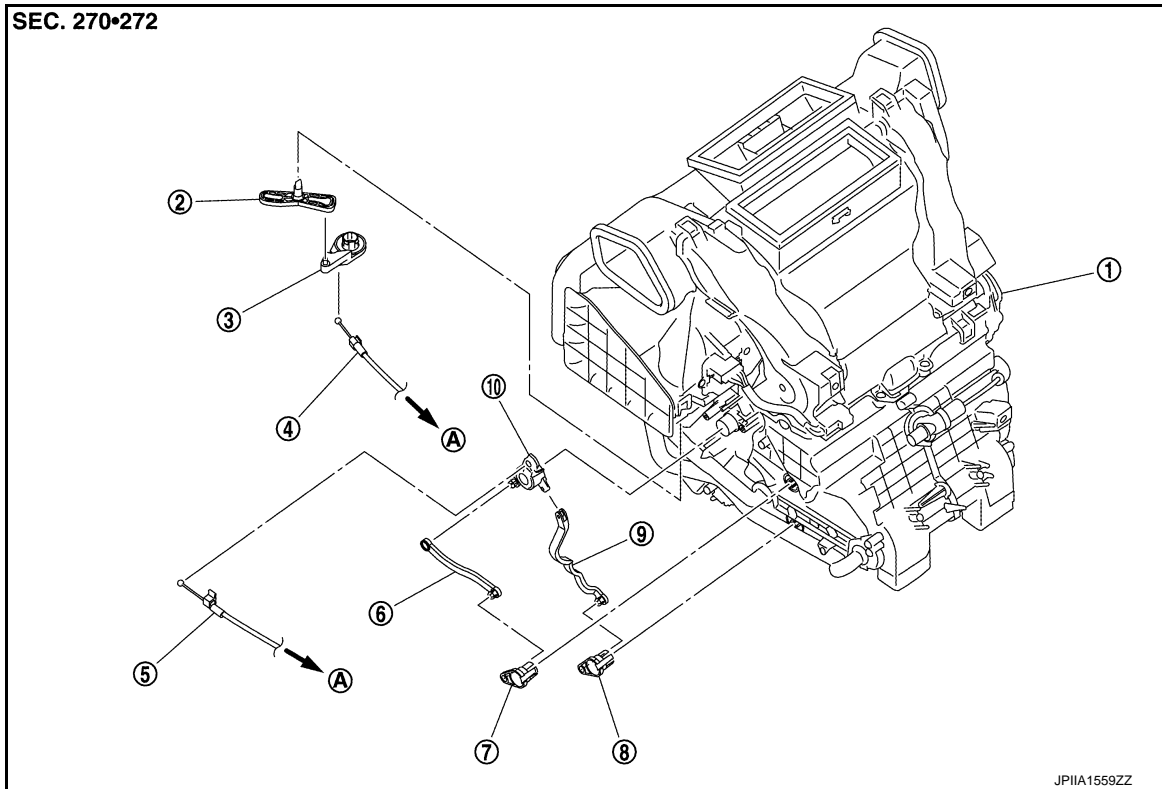

- |                             |                             |                           |
|-----------------------------|-----------------------------|---------------------------|
| 1. A/C unit assembly        | 2. Intake door lever        | 3. Intake door link       |
| 4. Intake door cable        | 5. Air mix door cable       | 6. Upper air mix door rod |
| 7. Upper air mix door lever | 8. Lower air mix door lever | 9. Lower air mix door rod |
| 10. Air mix door link       |                             |                           |
| A. To A/C control           |                             |                           |

RIGHT SIDE

# DOOR CABLE

< REMOVAL AND INSTALLATION >

[MANUAL AIR CONDITIONING]

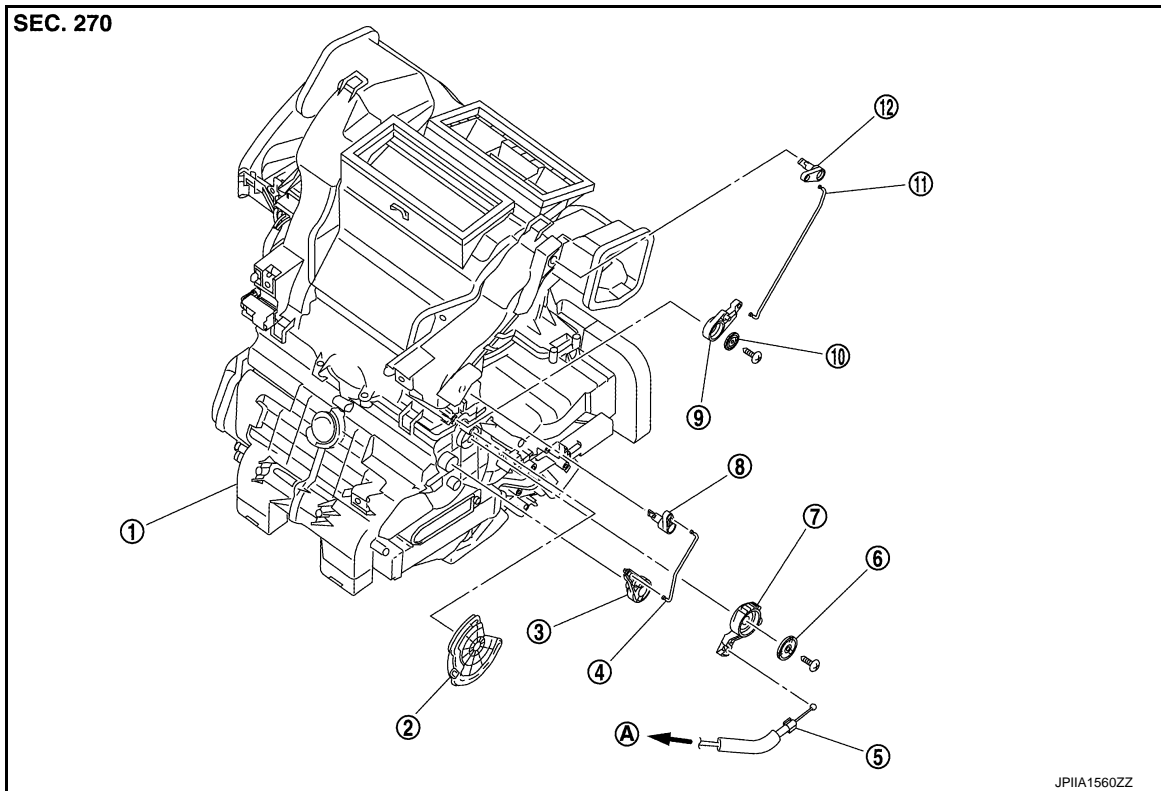

- |                           |  |  |
|---------------------------|--|--|
| 1. A/C unit assembly      | 2. Main link                                 | 3. Sub defroster door link                     |
| 4. Sub defroster door rod | 5. Mode door cable                           | 6. Plate                                       |
| 7. Mode link              | 8. Sub defroster door lever                  | 9. Center ventilator and defroster door link   |
| 10. Plate                 | 11. Center ventilator and defroster door rod | 12. Center ventilator and defroster door lever |
| A. To A/C control         |  |  |

HAC

## INTAKE DOOR CABLE

### INTAKE DOOR CABLE : Removal and Installation

INFOID:000000009754457

#### REMOVAL

1. Disconnect intake door cable from A/C control. Refer to [HAC-142. "Exploded View"](#).
2. Remove instrument lower panel LH. Refer to [IP-13. "Removal and Installation"](#).
3. Disconnect intake door cable from A/C unit assembly as shown by the arrow in the figure, and then remove intake door cable.

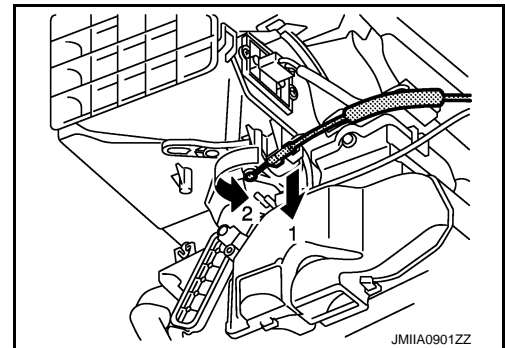

#### INSTALLATION

Install in the reverse order of removal.

## MODE DOOR CABLE

# DOOR CABLE

< REMOVAL AND INSTALLATION >

[MANUAL AIR CONDITIONING]

## MODE DOOR CABLE : Removal and Installation

INFOID:00000009754458

### REMOVAL

1. Disconnect mode door cable from A/C control. Refer to [HAC-142. "Exploded View"](#).
2. Remove glove box assembly. Refer to [IP-13. "Removal and Installation"](#).
3. Disconnect mode door cable from A/C unit assembly as shown by the arrow in the figure, and then remove mode door cable.

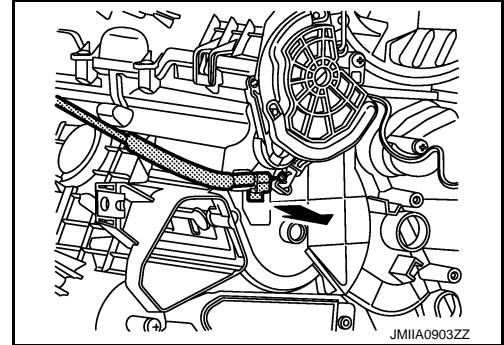

### INSTALLATION

Install in the reverse order of removal.

## AIR MIX DOOR CABLE

## AIR MIX DOOR CABLE : Removal and Installation

INFOID:00000009754459

### REMOVAL

1. Disconnect air mix door cable from A/C control. Refer to [HAC-142. "Exploded View"](#).
2. Remove instrument panel LH. Refer to [IP-13. "Removal and Installation"](#).
3. Disconnect air mix door cable from A/C unit assembly as shown by the arrow in the figure, and then remove air mix door cable.

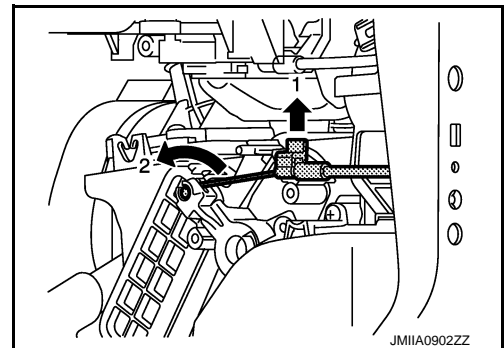

### INSTALLATION

Install in the reverse order of removal.