

SECTION **RAX**
REAR AXLE

A
B
C

RAX

CONTENTS

E

2WD	PREPARATION11	F
PRECAUTION 3	PREPARATION11	
PRECAUTIONS 3	Special Service Tool11	G
Precautions for Removing of Battery Terminal3	Commercial Service Tools11	
PREPARATION 4	SYMPTOM DIAGNOSIS13	H
PREPARATION 4	NOISE, VIBRATION AND HARSHNESS	
Commercial Service Tools4	(NVH) TROUBLESHOOTING13	I
SYMPTOM DIAGNOSIS 5	NVH Troubleshooting Chart13	
NOISE, VIBRATION AND HARSHNESS	PERIODIC MAINTENANCE14	
(NVH) TROUBLESHOOTING 5	REAR WHEEL HUB AND HOUSING14	J
NVH Troubleshooting Chart5	Inspection14	
PERIODIC MAINTENANCE 6	REAR DRIVE SHAFT15	K
REAR WHEEL HUB 6	Inspection15	
Inspection6	REMOVAL AND INSTALLATION16	L
REMOVAL AND INSTALLATION 7	REAR WHEEL HUB AND HOUSING16	
REAR WHEEL HUB 7	Exploded View16	M
Exploded View7	Removal and Installation16	
Removal and Installation7	Inspection17	N
Inspection8	REAR DRIVE SHAFT19	
SERVICE DATA AND SPECIFICATIONS	Exploded View19	O
(SDS) 9	Removal and Installation19	
SERVICE DATA AND SPECIFICATIONS	WHEEL SIDE20	P
(SDS) 9	WHEEL SIDE : Disassembly and Assembly20	
Wheel Bearing9	FINAL DRIVE SIDE23	
AWD	FINAL DRIVE SIDE : Disassembly and Assembly...23	
PRECAUTION10	Inspection25	
PRECAUTIONS10	SERVICE DATA AND SPECIFICATIONS	
Precautions for Drive Shaft10	(SDS)26	
Precautions for Removing of Battery Terminal 10	SERVICE DATA AND SPECIFICATIONS	
	(SDS)26	

Wheel Bearing	26	Drive Shaft	26
---------------------	----	-------------------	----

< PRECAUTION >

PRECAUTION

PRECAUTIONS

Precautions for Removing of Battery Terminal

INFOID:0000000010181603

- When removing the 12V battery terminal, turn OFF the ignition switch and wait at least 30 seconds.

NOTE:

ECU may be active for several tens of seconds after the ignition switch is turned OFF. If the battery terminal is removed before ECU stops, then a DTC detection error or ECU data corruption may occur.

- For vehicles with the 2-batteries, be sure to connect the main battery and the sub battery before turning ON the ignition switch.

NOTE:

If the ignition switch is turned ON with any one of the terminals of main battery and sub battery disconnected, then DTC may be detected.

- After installing the 12V battery, always check "Self Diagnosis Result" of all ECUs and erase DTC.

NOTE:

The removal of 12V battery may cause a DTC detection error.

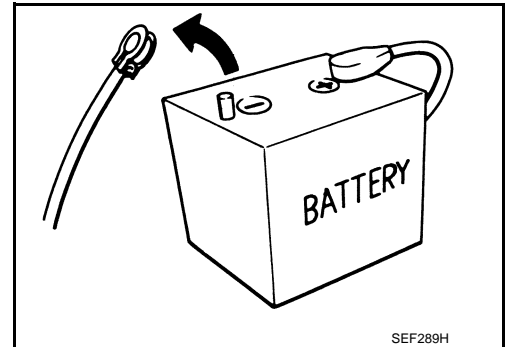

A
B
C
RAX
E
F
G
H
I
J
K
L
M
N
O
P

PREPARATION

< PREPARATION >

[2WD]

PREPARATION

PREPARATION

Commercial Service Tools

INFOID:000000009751006

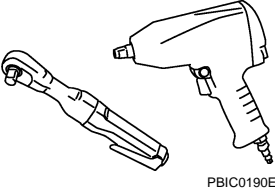
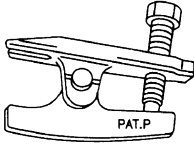
Tool name	Description
<p data-bbox="152 413 264 438">Power tool</p>  <p data-bbox="881 632 951 646">PBIC0190E</p>	<p data-bbox="1053 413 1305 441">Loosening bolts and nuts</p>
<p data-bbox="152 663 331 690">Ball joint remover</p>  <p data-bbox="841 821 878 835">PAT.P</p> <p data-bbox="881 884 924 898">NT146</p>	<p data-bbox="1053 663 1243 690">Removing hub bolt</p>

NOISE, VIBRATION AND HARSHNESS (NVH) TROUBLESHOOTING

< SYMPTOM DIAGNOSIS >

[2WD]

SYMPTOM DIAGNOSIS

NOISE, VIBRATION AND HARSHNESS (NVH) TROUBLESHOOTING

NVH Troubleshooting Chart

INFOID:000000009751007

Use chart below to find the cause of the symptom. If necessary, repair or replace these parts.

Reference		RAX-7	—	RAX-6	NVH in RAX and RSU sections	NVH in WT section	NVH in WT section	NVH in BR section
Possible cause and SUSPECTED PARTS		Improper installation, looseness	Parts interference	Wheel bearing damage	REAR AXLE AND REAR SUSPENSION	TIRE	ROAD WHEEL	BRAKE
Symptom	REAR AXLE	Noise	x	x	x	x	x	x
		Shake	x	x	x	x	x	x
		Vibration	x	x	x	x		
		Shimmy	x	x		x	x	x
		Judder	x			x	x	x
		Poor quality ride or handling	x	x		x	x	x

x: Applicable

A
B
C
RAX
E
F
G
H
I
J
K
L
M
N
O
P

PERIODIC MAINTENANCE

REAR WHEEL HUB

Inspection

INFOID:000000009751008

COMPONENT PART

Check the mounting conditions (looseness, back lash) of each component and component conditions (wear, damage) are normal.

WHEEL HUB ASSEMBLY (BEARING-INTEGRATED TYPE)

Check the following items, and replace the part it necessary.

- Move wheel hub assembly in the axial direction by hand. Check there is no looseness of wheel bearing.

Axial end play : Refer to [RAX-9, "Wheel Bearing"](#).

- Rotate wheel hub assembly and check there is no unusual noise or other irregular conditions. If there is any of irregular conditions, replace wheel hub assembly.

REAR WHEEL HUB

< REMOVAL AND INSTALLATION >

[2WD]

REMOVAL AND INSTALLATION

REAR WHEEL HUB

Exploded View

INFOID:000000009751009

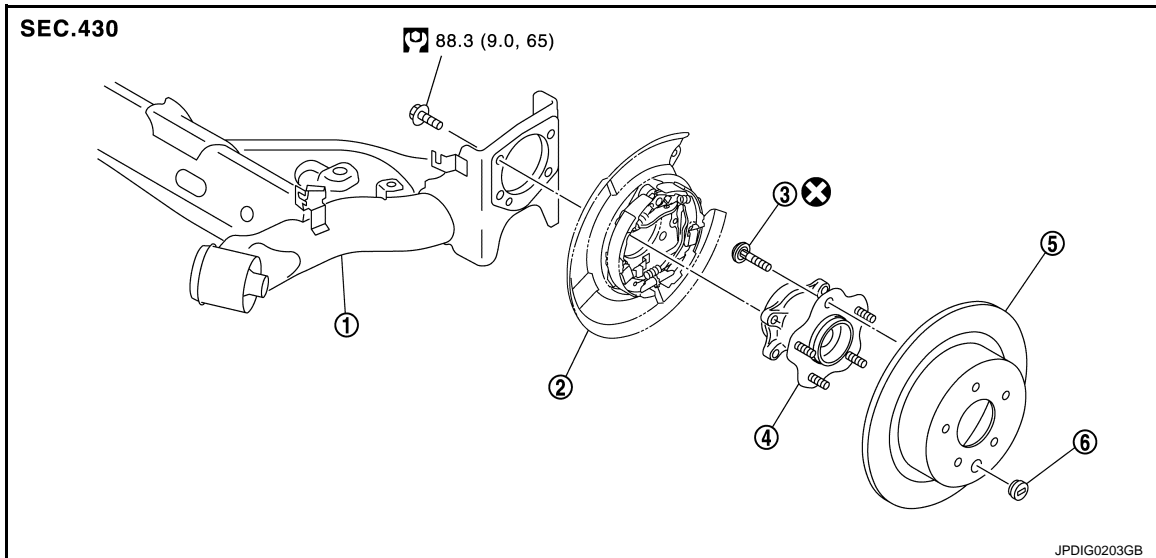

- | | | |
|---|---------------------------|-------------|
| 1. Rear suspension beam | 2. Parking brake assembly | 3. Hub bolt |
| 4. Wheel hub assembly (Bearing-integrated type) | 5. Disc rotor | 6. Plug |

⊗: Always replace after every disassembly.

🔧: N·m (kg·m, ft·lb)

Removal and Installation

INFOID:000000009751010

REMOVAL

1. Remove tires with power tool. Refer to [WT-46, "Removal and Installation"](#).
2. Remove wheel sensor. Refer to [BRC-135, "REAR WHEEL SENSOR : Removal and Installation"](#).
3. Remove caliper assembly. Hang caliper assembly in a place where it will not interfere with work. Refer to [BR-53, "BRAKE CALIPER ASSEMBLY : Removal and Installation"](#).

CAUTION:

Never depress brake pedal while brake caliper is removed.

4. Remove disc rotor. If disc rotor cannot be removed, remove as follows.

CAUTION:

- Parking brake completely in the released position.
- Put matching marks (A) on the wheel hub assembly and the disc rotor before removing the disc rotor.
- Never drop disc rotor.

- a. Fix the disc rotor with wheel nuts and remove the adjusting hole plug.

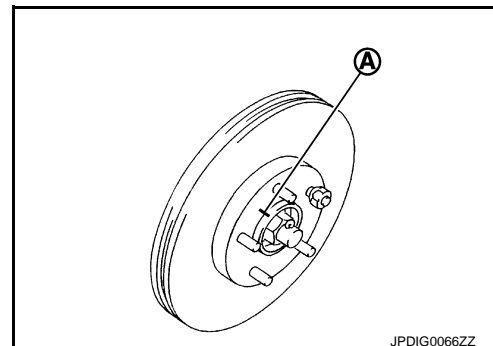

REAR WHEEL HUB

[2WD]

< REMOVAL AND INSTALLATION >

- b. Using suitable tool, rotate adjuster (1) in the direction (A) to retract and loosen brake shoe.
- c. Remove disc rotor.
5. Remove wheel hub assembly.

CAUTION:

Never remove parking brake assembly. Protect it from falling.

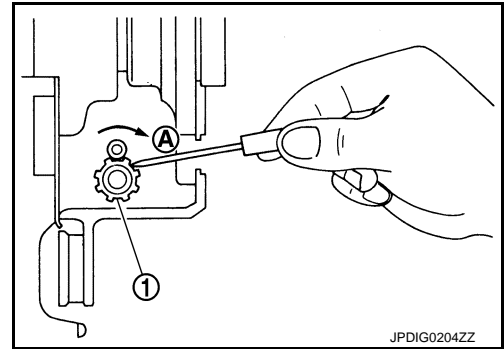

6. Remove hub bolts (1) from wheel hub assembly, using the ball joint remover (A) (commercial service tool).

CAUTION:

- Remove hub bolt only when necessary.
- Never hammer the hub bolt to avoid impact to the wheel hub assembly.
- Pull out the hub bolt in a direction perpendicular to the wheel hub assembly.

7. Perform inspection after removal. Refer to [RAX-8. "Inspection"](#).

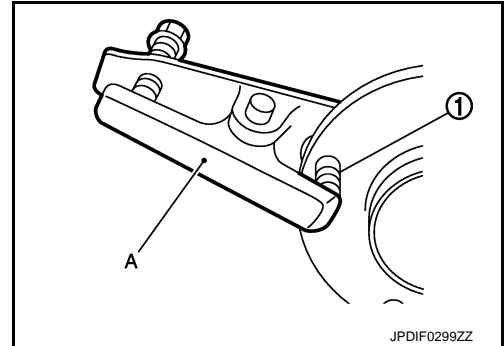

INSTALLATION

Note the following, and install in the reverse order of removal.

- Place a washer (A) as shown in the figure to install the hub bolts (1) by using the tightening force of the nut (B).

CAUTION:

- Check that there is no clearance between wheel hub assembly and hub bolt.
 - Never reuse hub bolt.
- Align the matching marks that have been made during removal when reusing the disc rotor.
 - Perform inspection after installation. Refer to [RAX-8. "Inspection"](#).

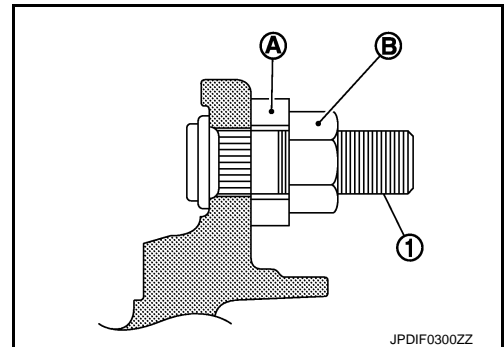

Inspection

INFOID:000000009751011

INSPECTION AFTER REMOVAL

Check the wheel hub assembly for wear, cracks, and damage. Replace if necessary.

INSPECTION AFTER INSTALLATION

1. Check wheel sensor harness for proper connection. [BRC-135. "REAR WHEEL SENSOR : Removal and Installation"](#).
2. Adjust parking brake operation (stroke). Refer to [PB-10. "Inspection and Adjustment"](#).
3. Check wheel alignment. Refer to [RSU-7. "Inspection"](#).
4. Adjust neutral position of steering angle sensor. Refer to [BRC-62. "Work Procedure"](#).

SERVICE DATA AND SPECIFICATIONS (SDS)

< SERVICE DATA AND SPECIFICATIONS (SDS)

[2WD]

SERVICE DATA AND SPECIFICATIONS (SDS)

SERVICE DATA AND SPECIFICATIONS (SDS)

Wheel Bearing

INFOID:000000009751012

Item	Standard
Axial end play	0.05 mm (0.002 in) or less

A

B

C

RAX

E

F

G

H

I

J

K

L

M

N

O

P

< PRECAUTION >

PRECAUTION

PRECAUTIONS

Precautions for Drive Shaft

INFOID:000000009751013

- Observe the following precautions when disassembling and assembling drive shaft.
 - Never disassemble joint sub-assembly because it is non-overhaul parts.
 - Perform work in a location which is as dust-free as possible.
 - Clean the parts, before disassembling and assembling.
 - Prevent the entry of foreign objects during disassembly of the service location.
 - Reassemble disassembled parts carefully in the correct order. If work is interrupted, a clean cover must be placed over parts.
 - Use paper waste. Fabric shop cloths must not be used because of the danger of lint adhering to parts.
 - Clean disassembled parts (except for rubber parts) with kerosene which shall be removed by blowing with air or wiping with paper waste.

Precautions for Removing of Battery Terminal

INFOID:000000010181604

- When removing the 12V battery terminal, turn OFF the ignition switch and wait at least 30 seconds.

NOTE:

ECU may be active for several tens of seconds after the ignition switch is turned OFF. If the battery terminal is removed before ECU stops, then a DTC detection error or ECU data corruption may occur.

- For vehicles with the 2-batteries, be sure to connect the main battery and the sub battery before turning ON the ignition switch.

NOTE:

If the ignition switch is turned ON with any one of the terminals of main battery and sub battery disconnected, then DTC may be detected.

- After installing the 12V battery, always check "Self Diagnosis Result" of all ECUs and erase DTC.

NOTE:

The removal of 12V battery may cause a DTC detection error.

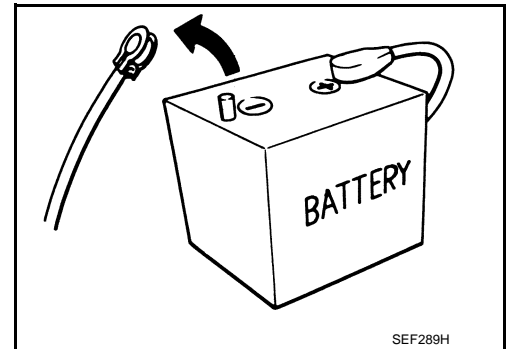

PREPARATION

[AWD]

< PREPARATION >

PREPARATION

PREPARATION

Special Service Tool

INFOID:000000009751014

The actual shapes of Kent-Moore tools may differ from those of special service tools illustrated here.

Tool number (Kent-More No.) Tool name	Description
KV38100500 (—) Drift a: 80 mm (3.15 in) dia. b: 60 mm (2.36 in) dia.	Installing sensor rotor
KV40101840 (—) Color a: 67 mm (2.64 in) dia. b: 85 mm (3.35 in) dia.	Installing sensor rotor
KV40107300 (—) Boot band crimping tool	Installing boot band
KV38107900 (—) Protector a: 32 mm (1.26 in) dia.	Installing drive shaft

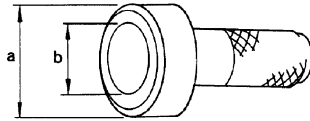

ZZA0701D

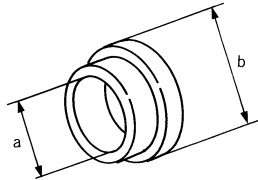

ZZA1113D

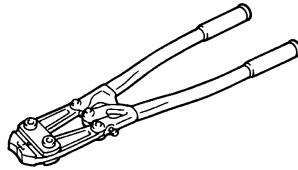

ZZA1229D

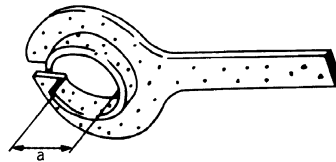

PDIA1183J

Commercial Service Tools

INFOID:000000009751015

A
B
C
RAX
E
F
G
H
I
J
K
L
M
N
O
P

PREPARATION

< PREPARATION >

[AWD]

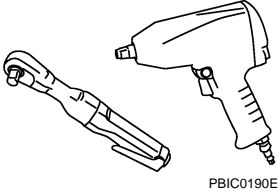
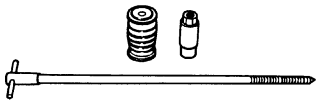
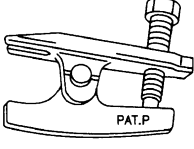
Tool name	Description
<p data-bbox="154 199 267 226">Power tool</p>  <p data-bbox="885 415 954 430">PBIC0190E</p>	<p data-bbox="1057 199 1307 226">Loosening bolts and nuts</p>
<p data-bbox="154 451 324 478">Drive shaft puller</p>  <p data-bbox="885 667 971 682">JPDIG0152ZZ</p>	<p data-bbox="1057 451 1461 478">Removing drive shaft joint sub assembly</p>
<p data-bbox="154 703 332 730">Ball joint remover</p>  <p data-bbox="885 919 933 934">NT146</p>	<p data-bbox="1057 703 1242 730">Removing hub bolt</p>

NOISE, VIBRATION AND HARSHNESS (NVH) TROUBLESHOOTING

< SYMPTOM DIAGNOSIS >

[AWD]

SYMPTOM DIAGNOSIS

NOISE, VIBRATION AND HARSHNESS (NVH) TROUBLESHOOTING

NVH Troubleshooting Chart

INFOID:000000009751016

Use chart below you find the cause of the symptom. If necessary, repair or replace these parts.

Reference			—	RAX-25	—	RAX-19	—	NVH in DLN section	NVH in DLN section	NVH in RAX and RSU sections	Refer to REAR AXLE in this chart	NVH in WT section	NVH in WT section	Refer to DRIVE SHAFT in this chart	NVH in BR section	
Possible cause and SUSPECTED PARTS			Excessive joint angle	Joint sliding resistance	Imbalance	Improper installation, looseness	Parts interference	PROPELLER SHAFT	DIFFERENTIAL	REAR AXLE AND REAR SUSPENSION	REAR AXLE	TIRE	ROAD WHEEL	DRIVE SHAFT	BRAKE	
Symptom	DRIVE SHAFT	Noise	x	x				x	x	x	x	x	x	x	x	
		Shake	x		x			x		x	x	x	x		x	
	REAR AXLE	Noise					x	x	x	x	x		x	x	x	x
		Shake					x	x	x		x		x	x	x	x
		Vibration					x	x	x		x		x		x	
		Shimmy					x	x			x		x	x		x
		Judder					x				x		x	x		x
		Poor quality ride or handling					x	x			x		x	x		

x: Applicable

A
B
C
RAX
E
F
G
H
I
J
K
L
M
N
O
P

PERIODIC MAINTENANCE

REAR WHEEL HUB AND HOUSING

Inspection

INFOID:000000009751017

COMPONENT PART

Check the mounting conditions (looseness, back lash) of each component and component conditions (wear, damage) are normal.

WHEEL HUB ASSEMBLY (BEARING-INTEGRATED TYPE)

Check the following items, and replace the part if necessary.

- Move wheel hub assembly in the axial direction by hand. Check there is no looseness of wheel bearing.

Axial end play : Refer to [RAX-26. "Wheel Bearing"](#).

- Rotate wheel hub assembly and check there is no unusual noise or other irregular conditions. If there is any of irregular conditions, replace wheel hub assembly.

REAR DRIVE SHAFT

< PERIODIC MAINTENANCE >

[AWD]

REAR DRIVE SHAFT

Inspection

INFOID:000000009751018

- Check drive shaft mounting point and joint for looseness and other damage.
- Check boot for cracks and other damage.

CAUTION:

Replace entire drive shaft assembly when noise or vibration occur from drive shaft.

A

B

C

RAX

E

F

G

H

I

J

K

L

M

N

O

P

REAR WHEEL HUB AND HOUSING

< REMOVAL AND INSTALLATION >

[AWD]

REMOVAL AND INSTALLATION

REAR WHEEL HUB AND HOUSING

Exploded View

INFOID:000000009751019

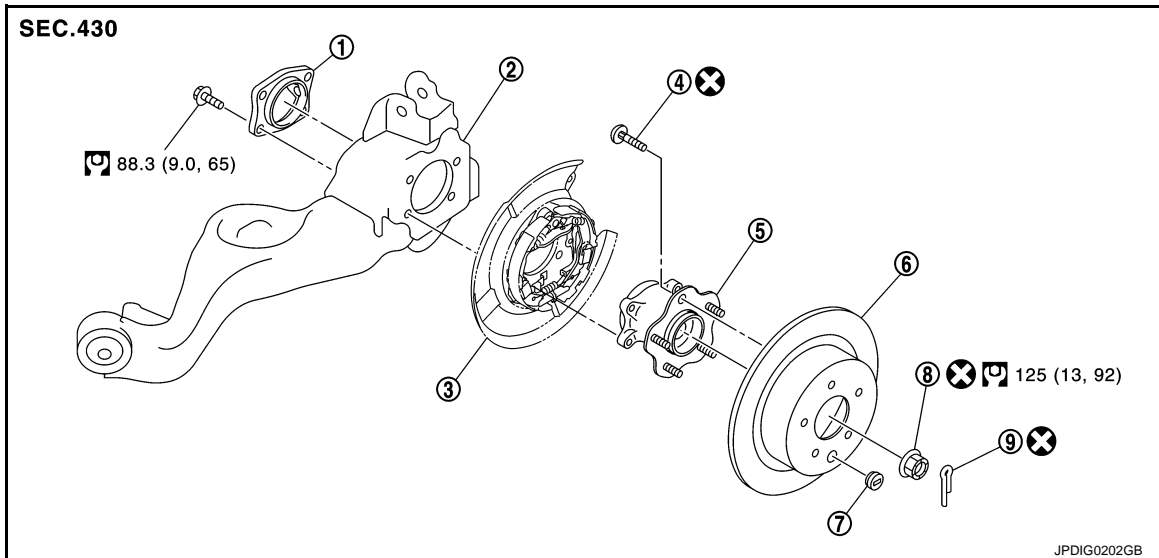

- | | | |
|-----------------|---|---------------------------|
| 1. Axle housing | 2. Suspension arm | 3. Parking brake assembly |
| 4. Hub bolt | 5. Wheel hub assembly (Bearing-integrated type) | 6. Disc rotor |
| 7. Plug | 8. Wheel hub lock nut | 9. Cotter pin |

⊗: Always replace after every disassembly.

Ⓜ: N·m (kg·m, ft·lb)

Removal and Installation

INFOID:000000009751020

REMOVAL

1. Remove tires with power tool. Refer to [WT-46, "Removal and Installation"](#).
2. Remove wheel sensor. Refer to [BRC-135, "REAR WHEEL SENSOR : Removal and Installation"](#).
3. Remove caliper assembly. Hang caliper assembly in a place where it will not interfere with work. Refer to [BR-53, "BRAKE CALIPER ASSEMBLY : Removal and Installation"](#).

CAUTION:

Never depress brake pedal while brake caliper is removed.

4. Remove disc rotor. If disc rotor cannot be removed, remove as follows.

CAUTION:

- Parking brake completely in the released position.
- Put matching marks (A) on the wheel hub assembly and the disc rotor before removing the disc rotor.
- Never drop disc rotor.

- a. Fix the disc rotor with wheel nuts and remove the adjusting hole plug.

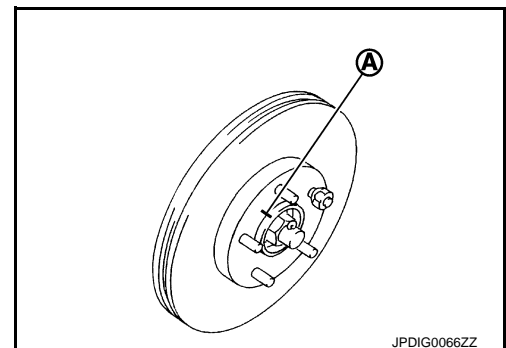

REAR WHEEL HUB AND HOUSING

[AWD]

< REMOVAL AND INSTALLATION >

- b. Using suitable tool, rotate adjuster (1) in the direction (A) to retract and loosen brake shoe.
- c. Remove disc rotor.
5. Remove cotter pin, and then loosen wheel hub lock nut with power tool.

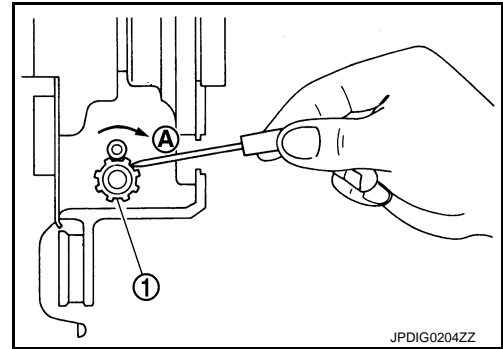

6. Patch wheel hub lock nut with a piece of wood. Hammer the wood to disengage wheel hub assembly from drive shaft.

CAUTION:

- Never place drive shaft joint at an extreme angle. Also be careful not to overextend slide joint.
- Never allow drive shaft to hang down without support for joint sub-assembly, shaft and the other parts.

NOTE:

Use suitable puller, if wheel hub assembly and drive shaft cannot be separated even after performing the above procedure.

7. Remove wheel hub lock nut.
8. Remove wheel hub assembly.

CAUTION:

Never remove parking brake assembly. Protect it from falling.

9. If axle housing need to be removed, remove drive shaft. Refer to [RAX-19, "Removal and Installation"](#).
10. Remove hub bolts (1) from wheel hub assembly, using the ball joint remover (A) (commercial service tool).

CAUTION:

- Remove hub bolt only when necessary.
- Never hammer the hub bolt to avoid impact to the wheel hub assembly.
- Pull out the hub bolt in a direction perpendicular to the wheel hub assembly.

11. Perform inspection after removal. Refer to [RAX-17, "Inspection"](#).

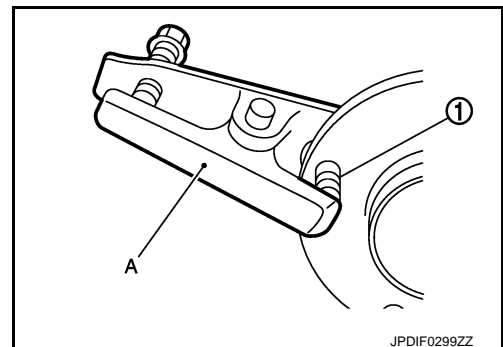
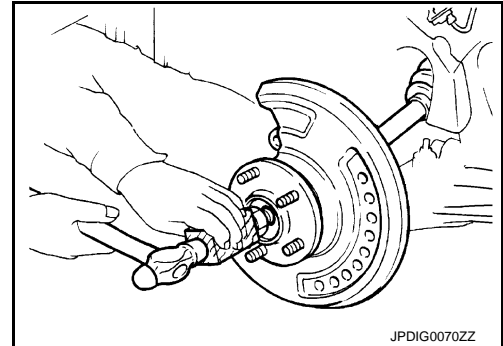

INSTALLATION

Note the following, and install in the reverse order of the removal.

- Place a washer (A) as shown in the figure to install the hub bolts (1) by using the tightening force of the nut (B).

CAUTION:

- Check that there is no clearance between wheel hub assembly and hub bolt.
- Never reuse hub bolt.
- Never reuse wheel hub lock nut and cotter pin.
- Align the matching marks that have been made during removal when reusing the disc rotor.
- Perform inspection after installation. Refer to [RAX-17, "Inspection"](#).

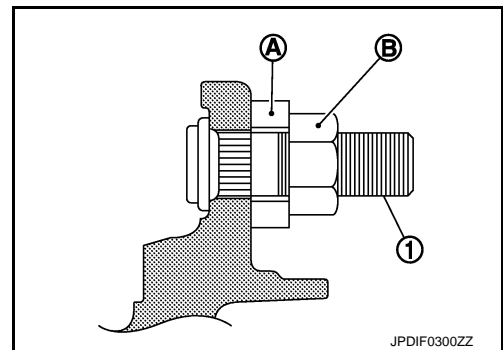

Inspection

INSPECTION AFTER REMOVAL

Check wheel hub assembly for wear, cracks, and damage. Replace if necessary.

INSPECTION AFTER INSTALLATION

INFOID:000000009751021

REAR WHEEL HUB AND HOUSING

[AWD]

< REMOVAL AND INSTALLATION >

1. Check wheel sensor harness for proper connection. [BRC-133, "REAR WHEEL SENSOR : Exploded View"](#).
2. Adjust parking brake operation (stroke). Refer to [PB-3, "Inspection and Adjustment"](#).
3. Check wheel alignment. Refer to [RSU-7, "Inspection"](#).
4. Adjust neutral position of steering angle sensor. Refer to [BRC-62, "Work Procedure"](#).

REAR DRIVE SHAFT

< REMOVAL AND INSTALLATION >

[AWD]

REAR DRIVE SHAFT

Exploded View

INFOID:000000009751022

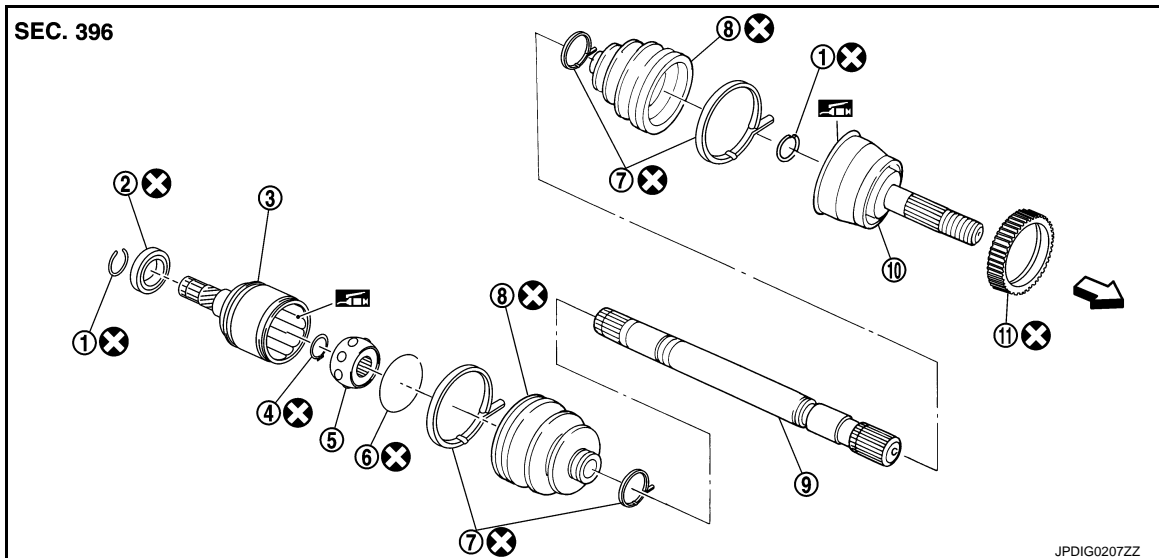

- | | | |
|------------------------|---|-----------------|
| 1. Circular clip | 2. Dust shield | 3. Housing |
| 4. Snap ring | 5. Ball cage/steel ball/inner race assembly | 6. Stopper ring |
| 7. Boot band | 8. Boot | 9. Shaft |
| 10. Joint sub-assembly | 11. Sensor rotor | |

⇐: Wheel side

: Fill NISSAN genuine grease or an equivalent.

: Always replace after every disassembly.

Removal and Installation

INFOID:000000009751023

REMOVAL

- Remove tires with power tool. Refer to [WT-46, "Removal and Installation"](#).
- Remove wheel sensor. Refer to [BRC-135, "REAR WHEEL SENSOR : Removal and Installation"](#).
- Remove caliper assembly. Hang caliper assembly in a place where it will not interfere with work. Refer to [BR-53, "BRAKE CALIPER ASSEMBLY : Removal and Installation"](#).
CAUTION:
Never depress brake pedal while brake caliper is removed.
- Remove disc rotor. Refer to [RAX-16, "Removal and Installation"](#).
- Remove cotter pin, and then loosen wheel hub lock nut with power tool. Refer to [RAX-16, "Removal and Installation"](#).
- Patch wheel hub lock nut with a piece of wood. Hammer the wood to disengage wheel hub assembly from drive shaft.
CAUTION:
 - Never place drive shaft joint at an extreme angle. Also be careful not to overextend slide joint.
 - Never allow drive shaft to hang down without support for joint sub-assembly, shaft and the other parts.**NOTE:**
Use suitable puller, if wheel hub assembly and drive shaft cannot be separated even after performing the above procedure.
- Remove wheel hub lock nut.
- Set jack under suspension arm.

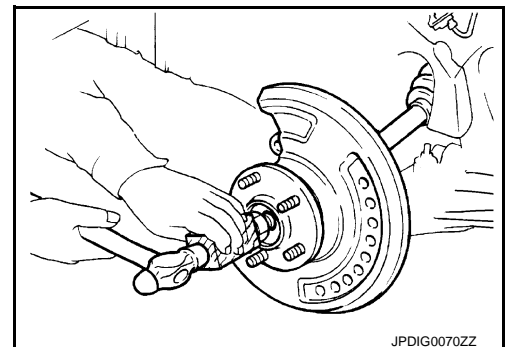

JPDIG0070ZZ

REAR DRIVE SHAFT

[AWD]

< REMOVAL AND INSTALLATION >

CAUTION:

- Never damage the suspension arm with a jack.
- Check the stable condition when using a jack.

9. Remove stabilizer link. Refer to [RSU-35, "Removal and Installation"](#).
10. Remove shock absorber from suspension arm. Refer to [RSU-24, "Removal and Installation"](#).
11. Remove upper link from suspension arm. Refer to [RSU-33, "Removal and Installation"](#).
12. Remove lower link from suspension arm. Refer to [RSU-31, "Removal and Installation"](#).
13. Remove drive shaft from final drive assembly.

CAUTION:

Confirm that the circular clip is attached to the drive shaft.

14. Perform inspection after removal. Refer to [RAX-25, "Inspection"](#).

INSTALLATION

Note the following, and install in the reverse order of removal.

- Place the protector (A) [SST:KV38107900 (—)] onto final drive assembly to prevent damage to the oil seal while inserting drive shaft. Slide drive shaft sliding joint and tap with a hammer to install securely.

CAUTION:

Check that circular clip is completely engaged.

- Perform final tightening of bolts and nuts at suspension arm (rubber bushing), under unladen conditions with tires on level ground.
- Perform inspection after installation. Refer to [RAX-25, "Inspection"](#).

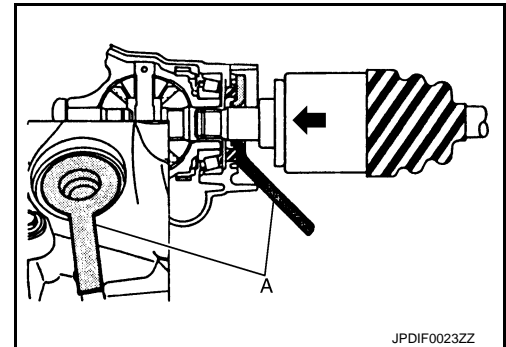

WHEEL SIDE

WHEEL SIDE : Disassembly and Assembly

INFOID:00000009751024

DISASSEMBLY

1. Fix shaft with a vise.

CAUTION:

Protect shaft using aluminum or copper plates when fixing with a vise.

2. If sensor rotor needs to be removed, use a bearing replacer (A) and puller (B).
3. Remove boot bands. Then remove boot from joint sub-assembly.

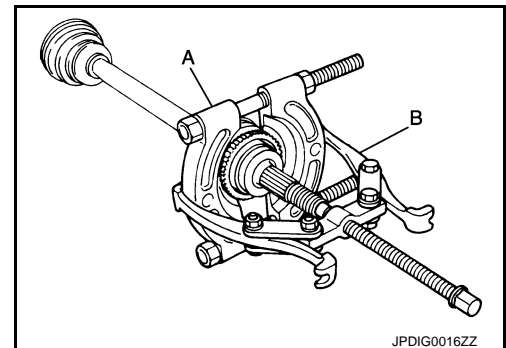

4. Screw drive shaft puller (A) (commercial service tool) into joint sub-assembly screw part to a length of 30 mm (1.18 in) or more. Support drive shaft with one hand and pull out joint sub-assembly from shaft.

CAUTION:

- Align drive shaft puller and drive shaft and remove them by pulling firmly and uniformly.
- If joint sub-assembly cannot be removed after five or more unsuccessful attempts, replace shaft and joint sub-assembly as a set.

5. Remove circular clip from shaft.
6. Remove boot from shaft.

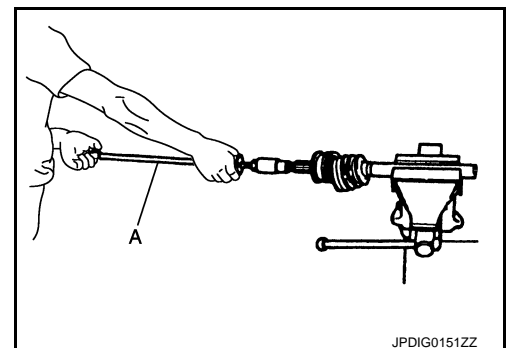

REAR DRIVE SHAFT

[AWD]

< REMOVAL AND INSTALLATION >

7. Perform inspection after disassembly. Refer to [RAX-25. "Inspection"](#).

ASSEMBLY

1. If sensor rotor (1) is removed, use a drift (A) [SST:KV38100500 (—)] and color (B) [SST:KV40101840 (—)] to press in a new one.

CAUTION:

Never reuse sensor rotor.

2. Clean the old grease on joint sub-assembly with paper waste.

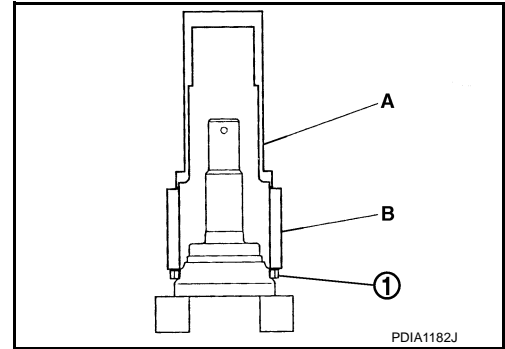

3. Fill serration slot joint sub-assembly (1) with NISSAN genuine grease or equivalent until the serration slot and ball groove become full to the brim.

CAUTION:

After applying grease, use a shop cloth to wipe off old grease that has oozed out.

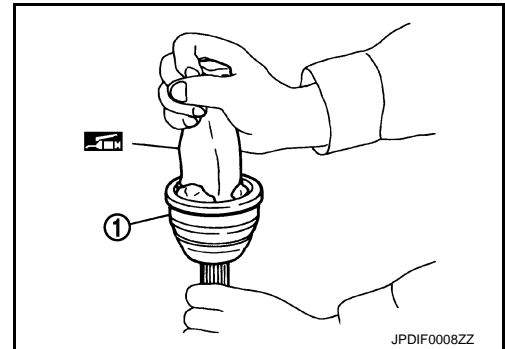

4. Install boot and boot bands to shaft.

CAUTION:

- Wrap serration on shaft with tape (A) to protect the boot from damage.
- Never reuse boot and boot band.

5. Remove the tape wrapped around the serrated on shaft.

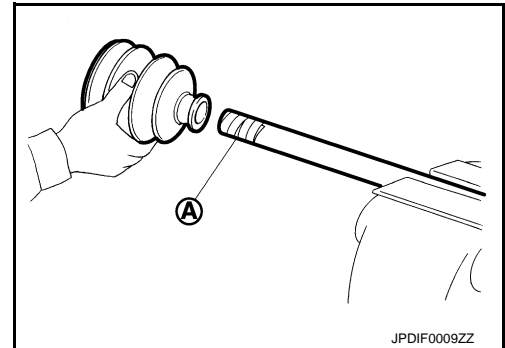

6. Position the circular clip (1) on groove at the shaft edge.

CAUTION:

Never reuse circular clip.

NOTE:

Drive joint inserter is recommended when installing circular clip.

7. Align both center axes of the shaft edge and joint sub-assembly. Then assemble shaft with joint sub-assembly holding circular clip.

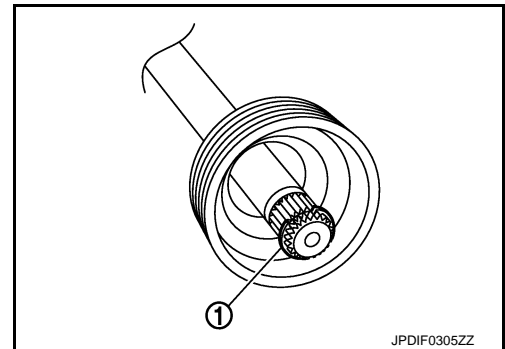

A
B
C
RAX
E
F
G
H
I
J
K
L
M
N
O
P

REAR DRIVE SHAFT

[AWD]

< REMOVAL AND INSTALLATION >

8. Install joint sub-assembly to shaft using plastic hammer.

CAUTION:

- Check circular clip is properly positioned on groove of the joint sub-assembly.
- Confirm that joint sub-assembly is correctly engaged while rotating drive shaft.

9. Apply the specified amount of grease into the boot inside from large diameter side of boot.

Grease amount : Refer to [RAX-26, "Drive Shaft"](#).

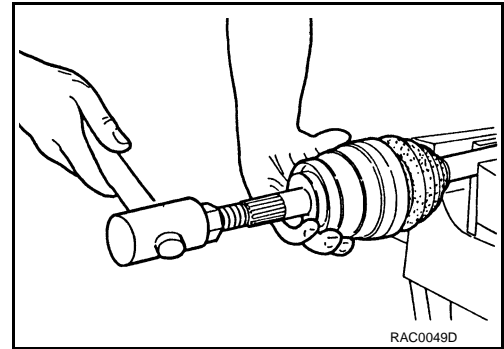

10. Install the boot securely into grooves (indicated by "*" marks) shown in the figure.

CAUTION:

If grease adheres to the boot mounting surface (indicated by "*" mark) on the shaft or joint sub-assembly, boot may be removed. Remove all grease from the boot mounting surface.

11. To prevent the deformation of the boot, adjust the boot installation length (L) to the specified value shown below by inserting the suitable tool into inside of the boot from the large diameter side of the boot and discharging the inside air.

L : Refer to [RAX-26, "Drive Shaft"](#).

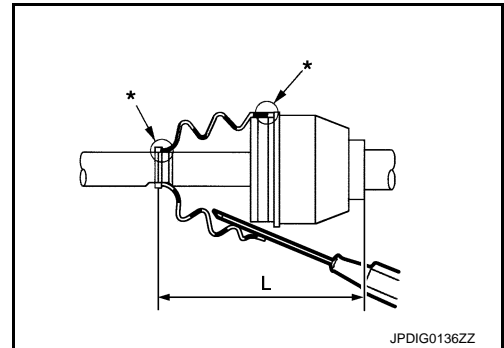

CAUTION:

- If the boot installation length exceeds the standard, it may cause breakage of the boot.
- Be careful not to touch the inside of the boot with a tip of tool.

12. Install boot bands securely.

CAUTION:

Never reuse boot band.

Small boot band

- Secure the ends of the boot with boot bands using the boot band crimping tool (A) [SST:KV40107300 (—)].

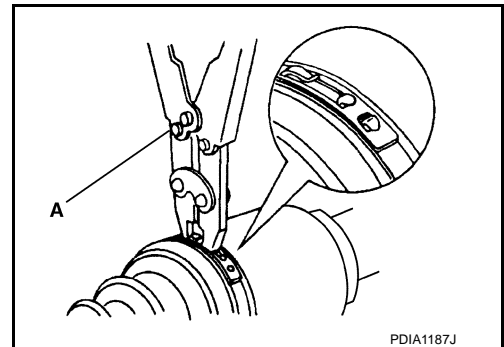

CAUTION:

Secure boot band so that dimension (M) meets the specification as shown in the figure.

M : 1.0 – 4.0 mm (0.039 – 0.157 in)

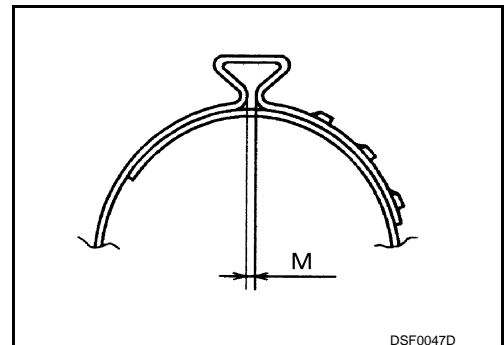

Large boot band

REAR DRIVE SHAFT

< REMOVAL AND INSTALLATION >

[AWD]

1. Put boot band in the groove on drive shaft boot. Then fit pawls (←) into holes to temporary installation.

NOTE:

For the large diameter side, fit projection (A) and guide slit (B) at first.

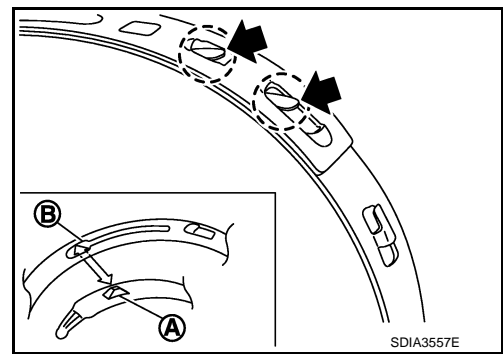

2. Pinch projection on the band with suitable pliers to tighten band.

3. Insert tip of band below end of the pawl.

13. Secure housing and shaft, and then make sure that they are in the correct position when rotating boot. Reinstall them using boot bands when boot installation positions become incorrect.

CAUTION:

Never reuse boot band.

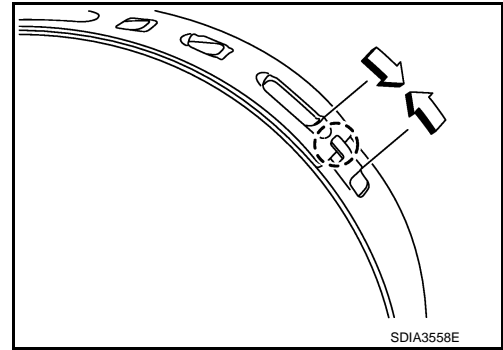

FINAL DRIVE SIDE

FINAL DRIVE SIDE : Disassembly and Assembly

INFOID:000000009751025

DISASSEMBLY

1. Fix shaft with a vise.

CAUTION:

Protect shaft using aluminum or copper plates when fixing with a vise.

2. Remove circular clip from housing.
3. Remove dust shield from housing.
4. Remove boot bands, and then remove boot from housing.
5. Put matching marks on housing and shaft.

CAUTION:

Use paint or an equivalent for matching marks. Never scratch the surfaces.

6. Remove stopper ring with suitable tool, and pull out housing.
7. Put matching marks on ball cage/steel ball/inner race assembly and shaft.

CAUTION:

Use paint or similar substance for matching marks. Never scratch the surface.

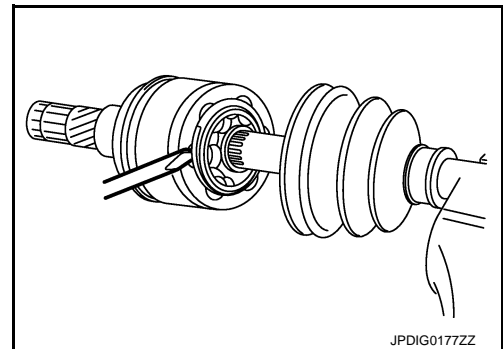

A
B
C
RAX
E
F
G
H
I
J
K
L
M
N
O
P

REAR DRIVE SHAFT

[AWD]

< REMOVAL AND INSTALLATION >

8. Remove snap ring, then remove ball cage/steel ball/inner race assembly from shaft.
9. Remove boot from shaft.
10. Perform inspection after disassembly. Refer to [RAX-25. "Inspection"](#).

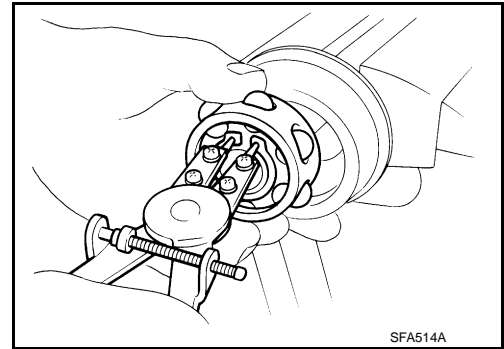

ASSEMBLY

1. Clean the old grease on housing with paper waste.
2. Install boot and boot bands to shaft.
CAUTION:
 - Wrap serration on shaft with tape (A) to protect boot from damage.
 - Never reuse boot and boot bands.
3. Remove the tape wrapped around the serration on shaft.

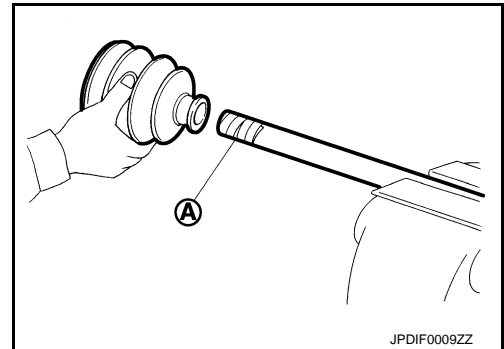

4. Install ball cage/steel ball/inner race assembly (1) to shaft (2), and secure them tightly with a snap ring (3).
CAUTION:
Never reuse snap ring.
5. Apply the appropriate amount of grease onto housing and slid surface.

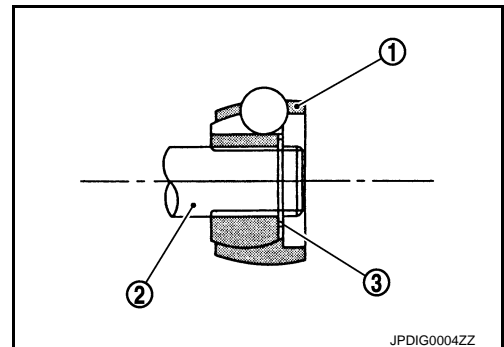

Grease amount : Refer to [RAX-26. "Drive Shaft"](#).

6. Install housing.
7. Install stopper ring to housing.
CAUTION:
Never reuse stopper ring.
8. After installed, pull shaft to check engagement between housing and stopper ring.
9. Install boot securely into grooves (indicated by "*" marks) shown in the figure.

CAUTION:
If grease adheres to the boot mounting surface (with "*" mark) on shaft or housing, boot may be removed. Remove all grease from the surface.

10. To prevent the deformation of the boot, adjust the boot installation length to the value shown below (L) by inserting the suitable tool into the inside of boot from the large diameter side of boot and discharging inside air.

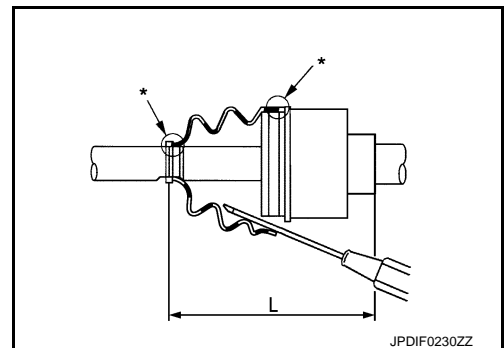

L : Refer to [RAX-26. "Drive Shaft"](#).

CAUTION:

- If the boot installation length exceeds the standard, it may cause breakage of the boot.
- Be careful not to touch the inside of the boot with the tip of tool.

REAR DRIVE SHAFT

[AWD]

< REMOVAL AND INSTALLATION >

11. Install boot bands securely as shown in the figure.
CAUTION:
Never reuse boot band.
12. Secure housing and shaft, and then make sure that they are in the correct position when rotating boot. Reinstall them using boot bands when boot installation positions become incorrect.
CAUTION:
Never reuse boot band.
13. Install dust shield to housing.
CAUTION:
Never reuse dust shield.
14. Install circular clip to housing.
CAUTION:
Never reuse circular clip.

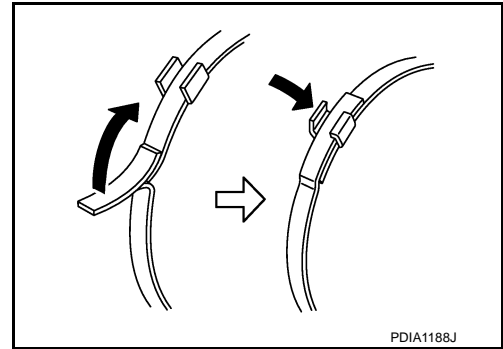

Inspection

INFOID:000000009751026

INSPECTION AFTER REMOVAL

- Move joint up/down, left/right, and in the axial directions. Check for motion that is not smooth and for significant looseness.
- Check boot for cracks, damage, and leakage of grease.

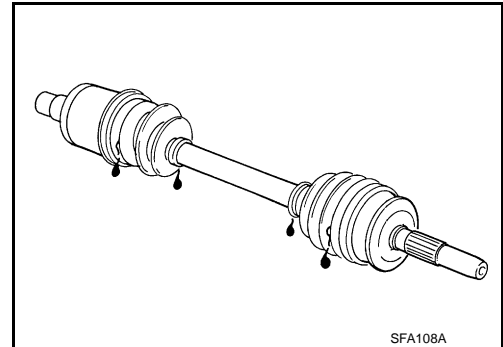

INSPECTION AFTER DISASSEMBLY

Check the following items, and replace the part if necessary.

Shaft

Check shaft for runout, cracks, or other damage.

Joint Sub-Assembly (Wheel Side)

Check the following:

- Joint sub-assembly for rough rotation and excessive axial looseness.
- The inside of the joint sub-assembly for entry of foreign material.
- Joint sub-assembly for compression scars, cracks, and fractures inside of joint sub-assembly.

Replace joint sub-assembly if there are any non-standard conditions of components.

Housing and Ball Cage/Steel Ball/Inner Race Assembly (Final Drive Side)

Replace housing and ball cage/steel ball/inner race assembly if there is scratching or wear of housing ball contact surface.

NOTE:

Housing and ball cage/steel ball/inner race assembly are used in a set.

A
B
C
RAX
E
F
G
H
I
J
K
L
M
N
O
P

SERVICE DATA AND SPECIFICATIONS (SDS)

< SERVICE DATA AND SPECIFICATIONS (SDS)

[AWD]

SERVICE DATA AND SPECIFICATIONS (SDS)

SERVICE DATA AND SPECIFICATIONS (SDS)

Wheel Bearing

INFOID:000000009751027

Item	Standard
Axial end play	0.05 mm (0.002 in) or less

Drive Shaft

INFOID:000000009751028

Item	Standard
Grease quantity	Wheel side 55 – 75 g (1.94 – 2.64 oz)
	Final drive side 65 – 85 g (2.30 – 2.99 oz)
Boots installed length*	Wheel side 123.5 mm (4.86 in)
	Final drive side 160.8 mm (6.33 in)

*: For measuring position, refer to [RAX-23, "FINAL DRIVE SIDE : Disassembly and Assembly"](#).