

RF
SECTION
ROOF

A
B
C

CONTENTS

PRECAUTION	INSPECTION AND ADJUSTMENT	F
PRECAUTIONS	ADDITIONAL SERVICE WHEN REPLACING CONTROL UNIT	G
Precaution for Supplemental Restraint System (SRS) "AIR BAG" and "SEAT BELT PRE-TENSIONER"	ADDITIONAL SERVICE WHEN REPLACING CONTROL UNIT : Description	H
Precaution for Procedure without Cowl Top Cover.....	ADDITIONAL SERVICE WHEN REPLACING CONTROL UNIT : Special Repair Requirement	H
Precautions for Removing of Battery Terminal	DTC/CIRCUIT DIAGNOSIS	I
PREPARATION	POWER SUPPLY AND GROUND CIRCUIT	J
PREPARATION	Diagnosis Procedure	J
Special Service Tool	SUNROOF MOTOR ASSEMBLY	RF
Commercial Service Tool	Component Function Check	L
SYSTEM DESCRIPTION	Diagnosis Procedure	M
COMPONENT PARTS	SUNROOF SWITCH	N
Component Parts Location	Component Function Check	O
Component Description	Diagnosis Procedure	P
SYSTEM	Component Inspection	
System Diagram	SYMPTOM DIAGNOSIS	
System Description	SUNROOF DOES NOT OPERATE PROPERLY	
ECU DIAGNOSIS INFORMATION	Description	
BCM (BODY CONTROL MODULE)	Diagnosis Procedure	
List of ECU Reference	AUTO OPERATION DOES NOT OPERATE	
SUNROOF SYSTEM	Description	
Reference Value	Diagnosis Procedure	
WIRING DIAGRAM	SUNROOF DOES NOT OPERATE ANTI-PINCH FUNCTION	
SUNROOF MOTOR ASSEMBLY	Diagnosis Procedure	
Wiring Diagram	RETAINED POWER OPERATION DOES NOT OPERATE PROPERLY	
BASIC INSPECTION	Diagnosis Procedure	
DIAGNOSIS AND REPAIR WORKFLOW		
WorkFlow		

D
E

F

G

H

I

J

RF

L

M

N

O

P

SQUEAK AND RATTLE TROUBLE DIAG- NOSES	28	SUNROOF UNIT ASSEMBLY	39
Work Flow	28	Exploded View	39
Inspection Procedure	30	Removal and Installation	40
Diagnostic Worksheet	32	Disassembly and Assembly	41
REMOVAL AND INSTALLATION	34	SUNSHADE	42
GLASS LID	34	Exploded View	42
Exploded View	34	Removal and Installation	42
Removal and Installation	34	WIND DEFLECTOR	44
Adjustment	35	Exploded View	44
SUNROOF MOTOR ASSEMBLY	37	Removal and Installation	44
Exploded View	37	SUNROOF SWITCH	45
Removal and Installation	37	Removal and Installation	45

PRECAUTIONS

< PRECAUTION >

PRECAUTION

PRECAUTIONS

Precaution for Supplemental Restraint System (SRS) "AIR BAG" and "SEAT BELT PRE-TENSIONER"

INFOID:000000009753712

The Supplemental Restraint System such as "AIR BAG" and "SEAT BELT PRE-TENSIONER", used along with a front seat belt, helps to reduce the risk or severity of injury to the driver and front passenger for certain types of collision. This system includes seat belt switch inputs and dual stage front air bag modules. The SRS system uses the seat belt switches to determine the front air bag deployment, and may only deploy one front air bag, depending on the severity of a collision and whether the front occupants are belted or unbelted. Information necessary to service the system safely is included in the "SRS AIR BAG" and "SEAT BELT" of this Service Manual.

WARNING:

Always observe the following items for preventing accidental activation.

- To avoid rendering the SRS inoperative, which could increase the risk of personal injury or death in the event of a collision that would result in air bag inflation, all maintenance must be performed by an authorized NISSAN/INFINITI dealer.
- Improper maintenance, including incorrect removal and installation of the SRS, can lead to personal injury caused by unintentional activation of the system. For removal of Spiral Cable and Air Bag Module, see "SRS AIR BAG".
- Never use electrical test equipment on any circuit related to the SRS unless instructed to in this Service Manual. SRS wiring harnesses can be identified by yellow and/or orange harnesses or harness connectors.

PRECAUTIONS WHEN USING POWER TOOLS (AIR OR ELECTRIC) AND HAMMERS

WARNING:

Always observe the following items for preventing accidental activation.

- When working near the Air Bag Diagnosis Sensor Unit or other Air Bag System sensors with the ignition ON or engine running, never use air or electric power tools or strike near the sensor(s) with a hammer. Heavy vibration could activate the sensor(s) and deploy the air bag(s), possibly causing serious injury.
- When using air or electric power tools or hammers, always switch the ignition OFF, disconnect the battery, and wait at least 3 minutes before performing any service.

Precaution for Procedure without Cowl Top Cover

INFOID:000000009753713

When performing the procedure after removing cowl top cover, cover the lower end of windshield with urethane, etc to prevent damage to windshield.

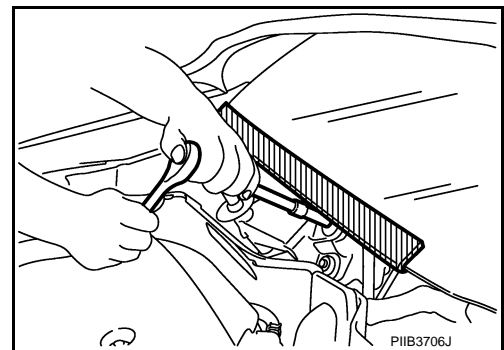

PRECAUTIONS

< PRECAUTION >

Precautions for Removing of Battery Terminal

INFOID:000000010169210

- When removing the 12V battery terminal, turn OFF the ignition switch and wait at least 30 seconds.

NOTE:

ECU may be active for several tens of seconds after the ignition switch is turned OFF. If the battery terminal is removed before ECU stops, then a DTC detection error or ECU data corruption may occur.

- For vehicles with the 2-batteries, be sure to connect the main battery and the sub battery before turning ON the ignition switch.

NOTE:

If the ignition switch is turned ON with any one of the terminals of main battery and sub battery disconnected, then DTC may be detected.

- After installing the 12V battery, always check "Self Diagnosis Result" of all ECUs and erase DTC.

NOTE:

The removal of 12V battery may cause a DTC detection error.

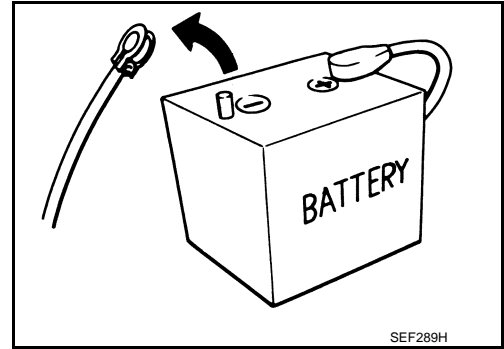

PREPARATION

< PREPARATION >

PREPARATION

PREPARATION

Special Service Tool

INFOID:000000009753714

The actual shapes of Kent-Moore tools may differ from those of special service tools illustrated here.

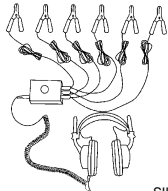
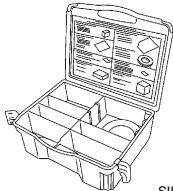
Tool number (Kent-Moore No.) Tool name	Description
(J-39570) Chassis ear  SIIA0993E	Locates the noise
(J-50397) NISSAN Squeak and Rattle Kit  SIIA0994E	Repairs the cause of noise

Commercial Service Tool

INFOID:000000009753715

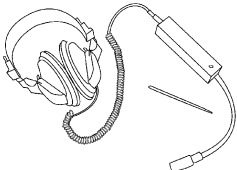
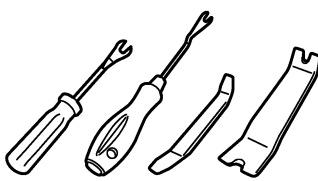
Tool name	Description
Engine ear  SIIA0995E	Locates the noise
Remover tool  JMKIA3050ZZ	Removes the clips, pawls and metal clips

COMPONENT PARTS

< SYSTEM DESCRIPTION >

SYSTEM DESCRIPTION

COMPONENT PARTS

Component Parts Location

INFOID:000000009753716

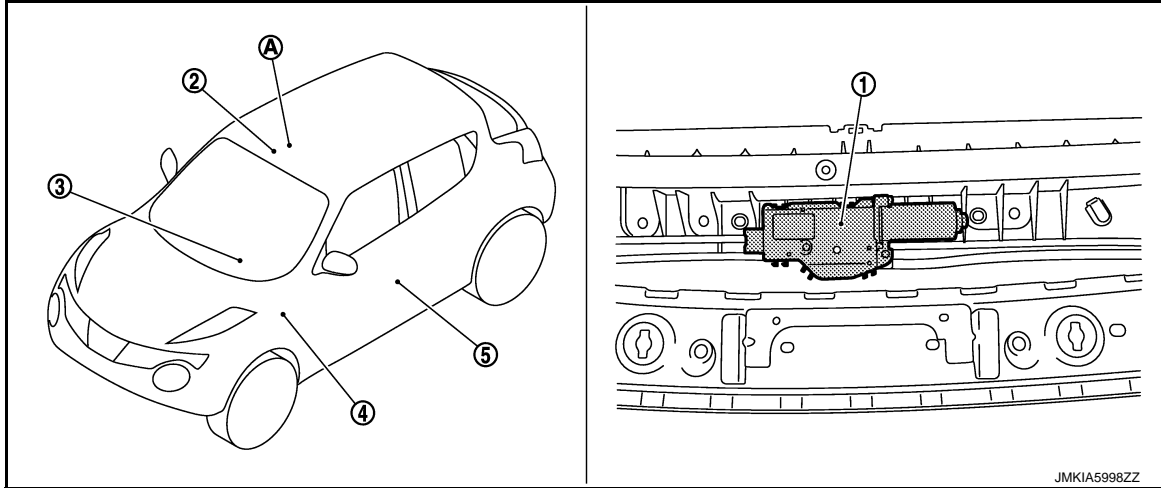

- 1. Sunroof motor assembly
 - 2. Sunroof switch
 - 3. Combination meter
 - 4. BCM
 - 5. Front door switch
 - A. View with headlining removed
- Refer to [BCS-6. "BODY CONTROL SYSTEM : Component Parts Location"](#).

Component Description

INFOID:000000009753717

Component	Function
BCM	Supplies the power supply to sunroof motor assembly.
Combination meter	Transmits vehicle speed signal to sunroof motor assembly.
Front door switch	Detects door open/close condition and transmits to BCM.
Sunroof motor assembly	It is sunroof motor and CPU integrated type that enables tilt up/down & slide open/close by sunroof switch operation.
Sunroof switch	Transmits tilt up/down & slides open/close operation signal to sunroof motor assembly.

SYSTEM

< SYSTEM DESCRIPTION >

SYSTEM

System Diagram

INFOID:000000009753718

SUNROOF

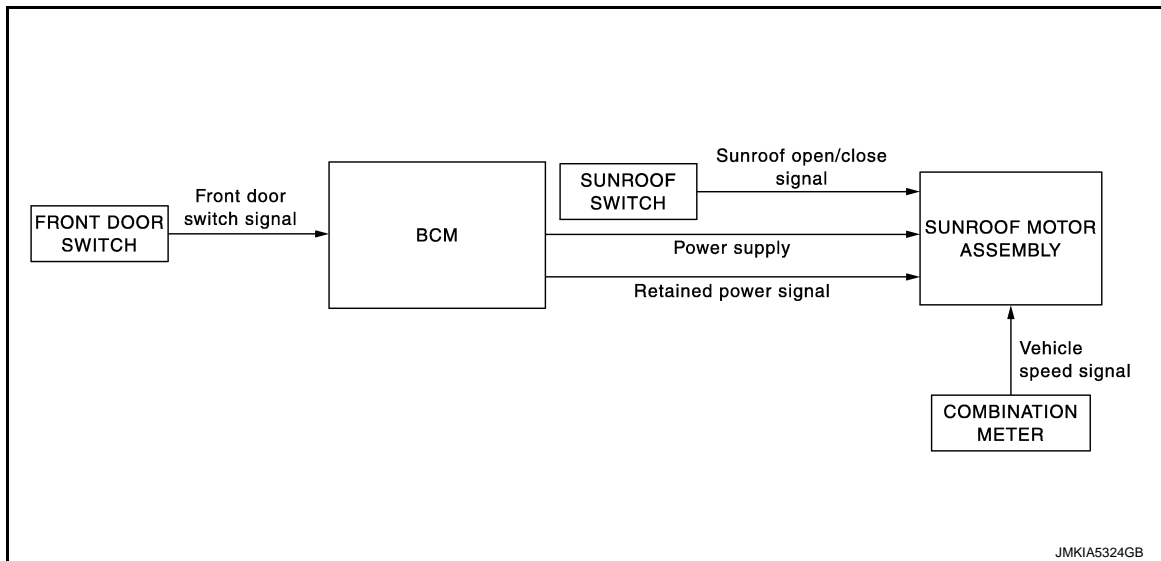

System Description



INFOID:000000009753719

SUNROOF SYSTEM

- Sunroof motor assembly operates with the power supply that is output from BCM while ignition switch is ON or retained power is operating.
- Tilt up/down & slide open/close signals from sunroof switch enables operate sunroof motor to move arbitrarily.
- Sunroof motor assembly receives a vehicle speed signal from combination meter and controls the sunroof motor operation.



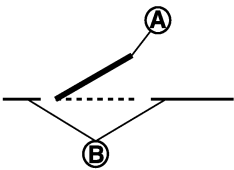



OPERATION DESCRIPTION

The sunroof operate to the following condition by the sunroof switch operation.

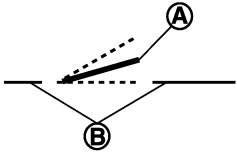
Sunroof position before operation	Switch operation	Sunroof action	Sunroof position after operation
Tilt up  <p>A: Glass lid B: Roof panel</p>	Close	Not action	—
	Open	Close	Fully-closed 

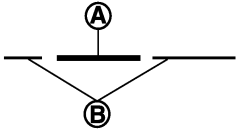
SYSTEM

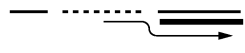
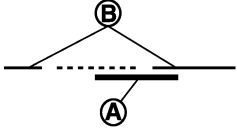
< SYSTEM DESCRIPTION >

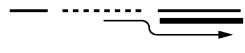
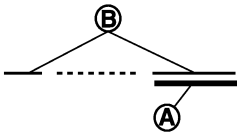
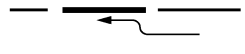
Sunroof position before operation	Switch operation	Sunroof action	Sunroof position after operation
Tilt halfway-open  A: Glass lid B: Roof panel JMKIA5778ZZ	Close	Tilt up	Tilt up  JMKIA5870ZZ
	Open	Close	Fully-closed  JMKIA5869ZZ
Fully-closed  A: Glass lid B: Roof panel JMKIA5779ZZ	Close	Tilt up	Tilt up  JMKIA5870ZZ
	Open	Open	Fully-open  JMKIA5871ZZ
Halfway-open  A: Glass lid B: Roof panel JMKIA5780ZZ	Close	Close	Fully-closed  JMKIA5872ZZ
	Open	Open	Fully-open  JMKIA5871ZZ
Fully-open  A: Glass lid B: Roof panel JMKIA5781ZZ	Close	Close	Fully-closed  JMKIA5872ZZ
	Open	Not action	—

SYSTEM

< SYSTEM DESCRIPTION >

AUTO OPERATION

Sunroof AUTO feature makes it possible to slide open and slide close or tilt up and tilt down the sunroof without holding the sunroof switch in the slide open/tilt down or slide close/tilt up position.

A

RETAINED POWER OPERATION

Retained power operation is an additional power supply function that enables sunroof system to operate during 45 seconds even when ignition switch is turned OFF.

B

RETAINED POWER FUNCTION CANCEL CONDITIONS

- Front door CLOSE (door switch OFF)→OPEN (door switch ON).
- When ignition switch is ON again.
- When timer time passes. (45 seconds)

C

ANTI-PINCH FUNCTION

The CPU of sunroof motor assembly monitors the sunroof motor operation and the sunroof position (fully-closed or other) by the signals from sunroof motor.

When sunroof motor detects an interruption during the following slide close and tilt down operation, sunroof switch controls the motor for open and the sunroof will operate until full up position (when tilt down operate) or 150 mm (5.91 in) or more in an open direction (when slide close operate).

D

E

F

G

H

I

J

RF

L

M

N

O

P

BCM (BODY CONTROL MODULE)

< ECU DIAGNOSIS INFORMATION >

ECU DIAGNOSIS INFORMATION

BCM (BODY CONTROL MODULE)

List of ECU Reference

INFOID:000000009753720

ECU	Reference
BCM	BCS-36. "Reference Value"
	BCS-57. "Fail-safe"
	BCS-58. "DTC Inspection Priority Chart"
	BCS-59. "DTC Index"

SUNROOF SYSTEM

< ECU DIAGNOSIS INFORMATION >

SUNROOF SYSTEM

Reference Value

INFOID:000000009753721

TERMINAL LAYOUT

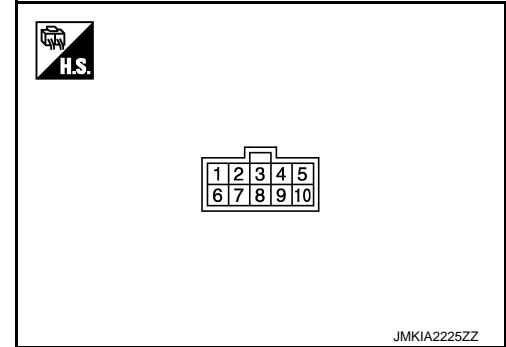

PHYSICAL VALUES

Terminal No. (Wire color)		Description		Condition	Voltage (V) (Approx.)
+	-	Signal name	Input/ Output		
1 (B)	Ground	Ground	—	—	0
3 (L)	Ground	Retained power signal	Input	Ignition switch ON	Battery voltage
				Within 45 second after ignition switch is turned to OFF	
5 (Y)	Ground	Sunroof open signal	Input	Sunroof switch: Open	0
				Ignition switch ON	Battery voltage
6 (P)	Ground	Sunroof power supply	Input	—	Battery voltage
8 (V)	Ground	Vehicle speed signal (8-pulse)	Input	Speedometer operated [When vehicle speed is approx.40km/ h (25MPH)]	<p style="text-align: right; font-size: small;">JSNIA0012GB</p>
10 (G)	Ground	Sunroof close signal	Input	Sunroof switch: Close	0
				Ignition switch ON	Battery voltage

SUNROOF MOTOR ASSEMBLY

< WIRING DIAGRAM >

WIRING DIAGRAM

SUNROOF MOTOR ASSEMBLY

Wiring Diagram

INFOID:000000009753722

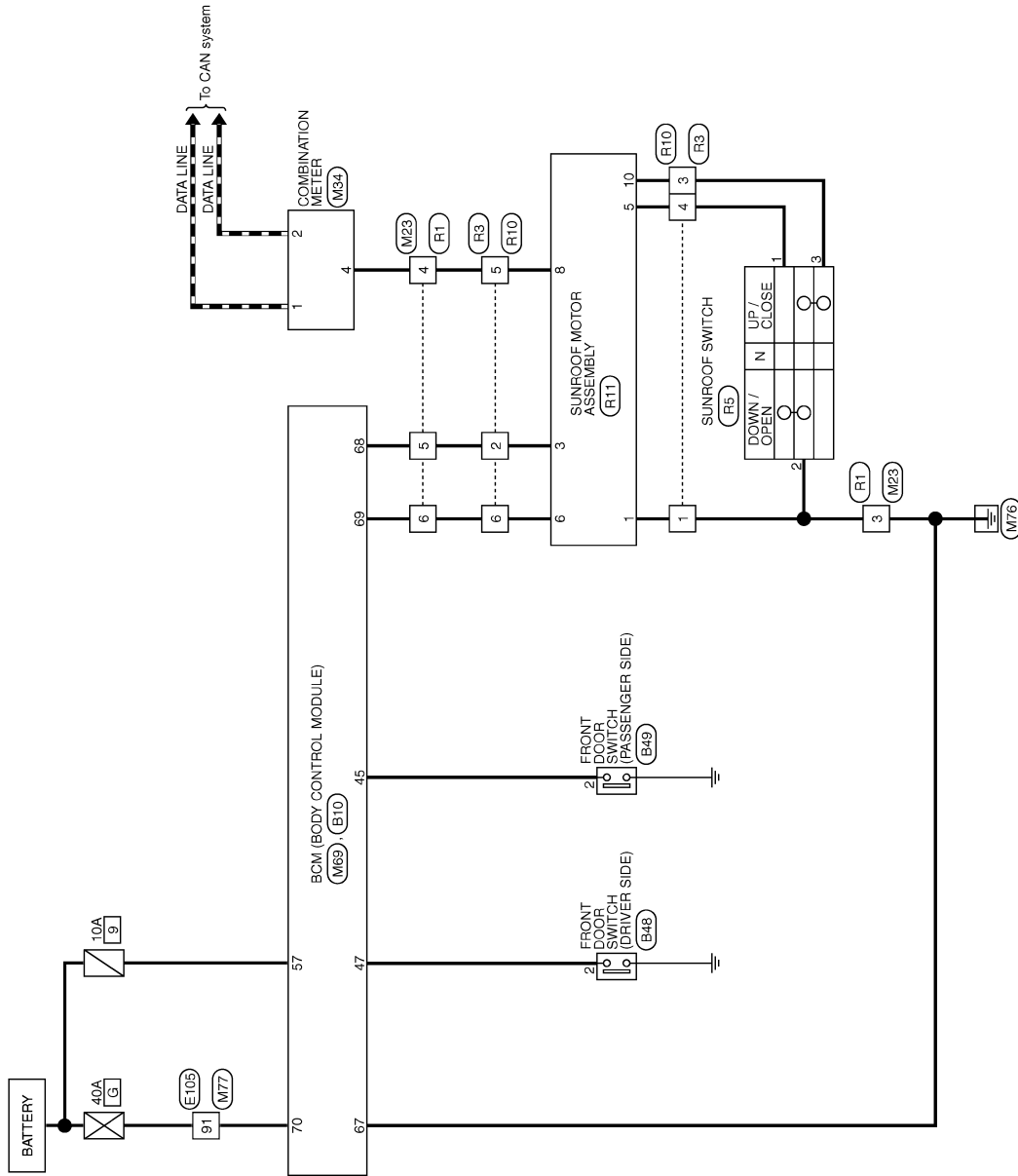

SUNROOF

2010/08/30

JCKWA3419GB

SUNROOF MOTOR ASSEMBLY

< WIRING DIAGRAM >

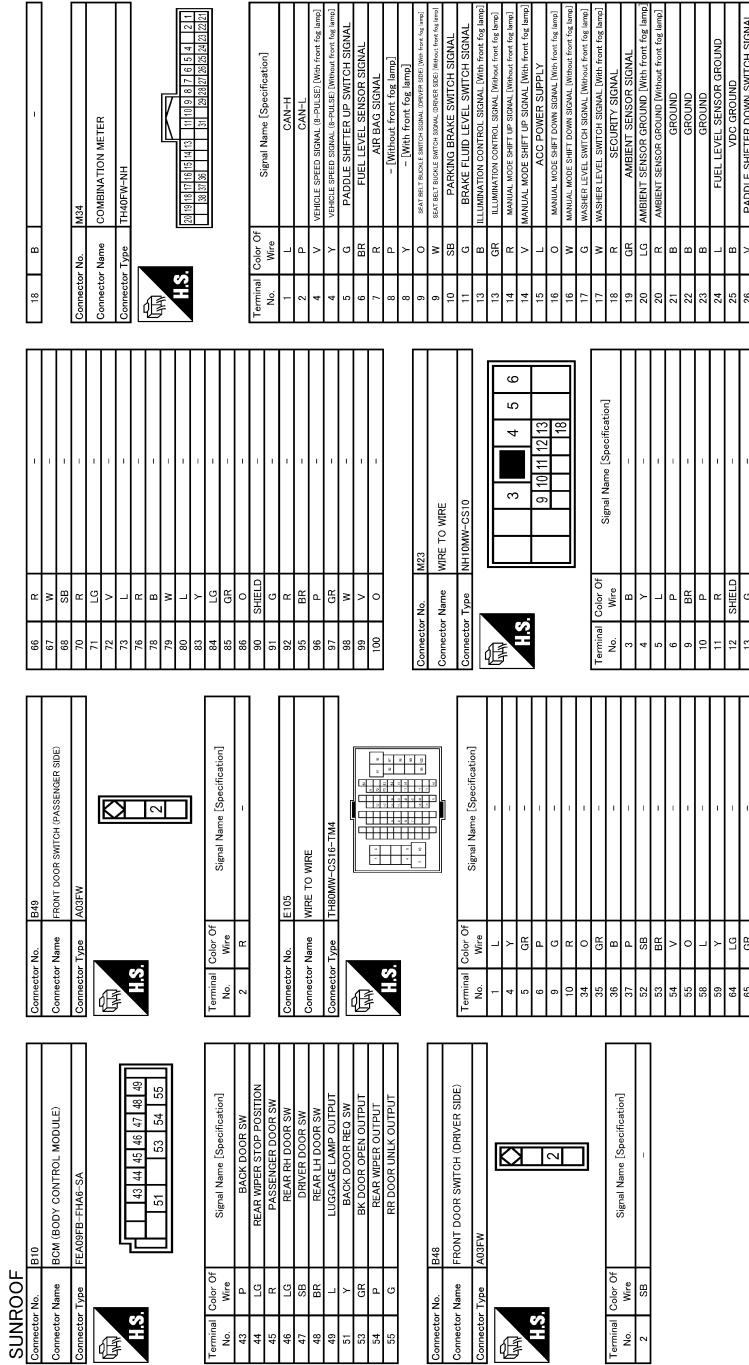

A
B
C
D
E
F
G
H
I
J
L
M
N
O
P

RF

JRKWC9430GB

SUNROOF MOTOR ASSEMBLY

< WIRING DIAGRAM >

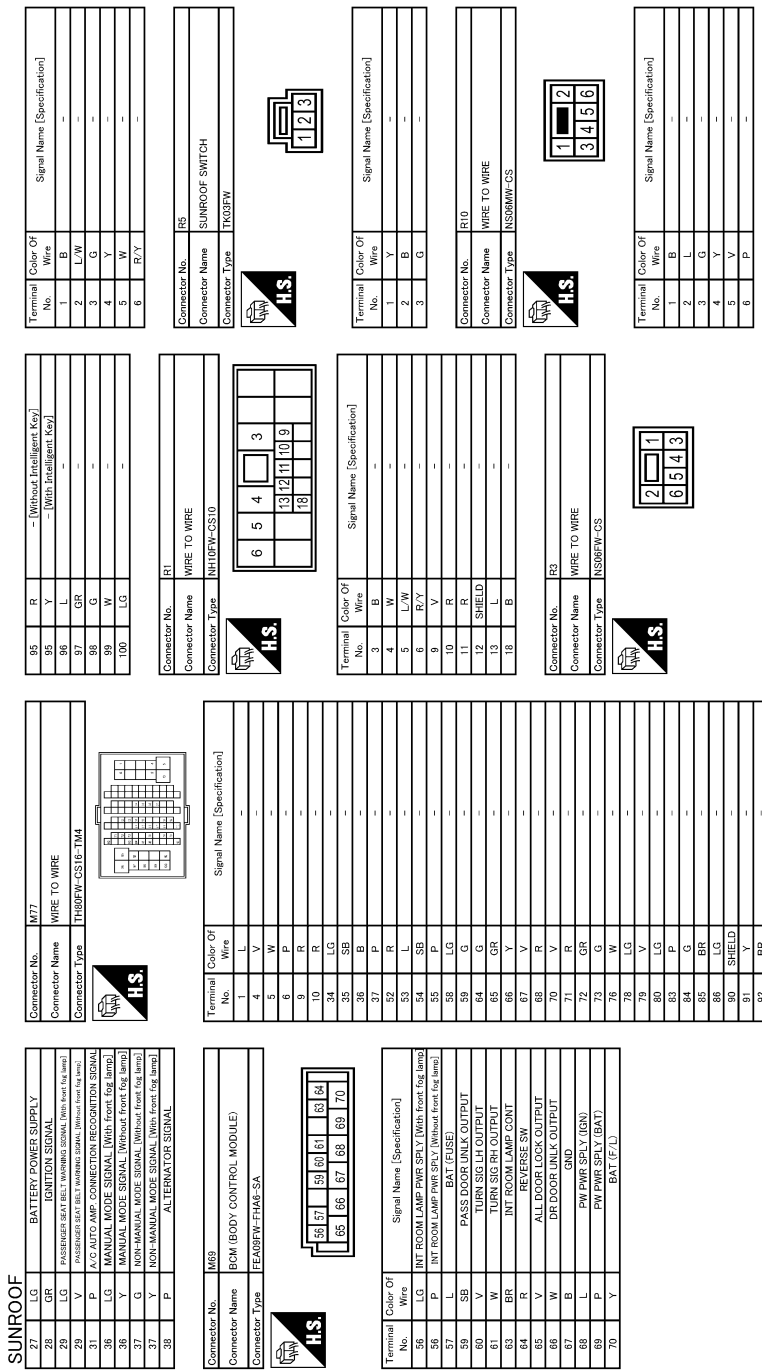

JRWKC9431GB

SUNROOF MOTOR ASSEMBLY

< WIRING DIAGRAM >

SUNROOF	
Connector No.	RF1
Connector Name	SUNROOF MOTOR ASSEMBLY
Connector Type	YEANDEGY

Terminal No.	Color Of Wire	Signal Name [Specification]
1	B	GNB
2	Y	SW-BIT 0
3	P	BAT
4	V	SPEED SENSOR (BP)
10	G	SW-BIT 1

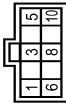

A
B
C
D
E
F
G
H
I
J
RF
L
M
N
O
P

JRKWC9432GB

DIAGNOSIS AND REPAIR WORKFLOW

< BASIC INSPECTION >

BASIC INSPECTION

DIAGNOSIS AND REPAIR WORKFLOW

WorkFlow

INFOID:000000009753723

DETAILED FLOW

1.OBTAIN INFORMATION ABOUT SYMPTOM

Interview the customer to obtain the malfunction information (conditions and environment when the malfunction occurred) as much as possible when the customer brings the vehicle in.

>> GO TO 2.

2.REPRODUCE THE MALFUNCTION INFORMATION

Check the malfunction on the vehicle that the customer describes.
Inspect the relation of the symptoms and the condition when the symptoms occur.

>> GO TO 3.

3.IDENTIFY THE MALFUNCTIONING SYSTEM WITH "SYMPTOM DIAGNOSIS"

Use "Symptom diagnosis" from the symptom inspection result in step 2 and then identify where to start performing the diagnosis based on possible causes and symptoms.

>> GO TO 4.

4.IDENTIFY THE MALFUNCTIONING PARTS WITH "COMPONENT DIAGNOSIS"

Perform the diagnosis with "Component diagnosis" of the applicable system.

>> GO TO 5.

5.REPAIR OR REPLACE THE MALFUNCTIONING PARTS

Repair or replace the specified malfunctioning parts.

>> GO TO 6.

6.FINAL CHECK

Check that malfunctions are not reproduced when obtaining the malfunction information from the customer, referring to the symptom inspection result in step 2.

Are the malfunctions corrected?

YES >> INSPECTION END

NO >> GO TO 3.

INSPECTION AND ADJUSTMENT

< BASIC INSPECTION >

INSPECTION AND ADJUSTMENT

ADDITIONAL SERVICE WHEN REPLACING CONTROL UNIT

ADDITIONAL SERVICE WHEN REPLACING CONTROL UNIT : Description

INFOID:000000009753724

MEMORY RESET PROCEDURE

1. Please observe the following instructions at confirming the sunroof operation.

NOTE:

Do not disconnect the electronic power while the sunroof is operating or within 5 seconds after the sunroof stops (to wipe-out the memory of lid position and operating friction).

2. Initialization of system should be conducted after the following conditions.
 - When the sunroof motor is changed.
 - When the sunroof does not operate normally. (Incomplete initialization conditions)

ADDITIONAL SERVICE WHEN REPLACING CONTROL UNIT : Special Repair Requirement

INFOID:000000009753725

INITIALIZATION PROCEDURE

If the sunroof does not close or open automatically, use the following procedure to return sunroof operation to normal.

1. Press tilt up switch several times and set glass lid to the tilt up position.
2. Release the tilt up switch once, press the tilt up switch again, press and hold the switch until lid pops up.
3. The glass lid moves slight toward tilt up direction then stop. (Press and hold the switch during this operation)
4. Release the switch again, and press the tilt up switch within the first 4 seconds. (Press and hold the switch)
5. After 4 seconds, the glass lid will be automatically operated in sequence of tilt down, slide open and slide close.
6. After the glass lid stops, release the switch 0.5 second later. (Press and hold the switch during this operation)
7. If slide switch operates normally, this initialization is done.

ANTI-PINCH FUNCTION

1. Full open the sunroof.
2. Place a wooden piece (wooden hammer handle, etc.) at near fully closed position.
3. Close the sunroof completely with auto-slide close.

Check that sunroof lowers for approximately 150 mm (5.91in) or 2 seconds with out pinching a wooden piece and stops.

CAUTION:

- **Never check with hands and other part of body because they may be pinched. Never get pinched.**
- **Depending on environment and driving conditions, if a similar impact or load is applied to the sunroof it may lower.**
- **Check that auto-slide operates before inspection when system initialization is performed.**
- **Perform initial setting when auto-slide operation or anti-pinch function does not operate normally.**

A
B
C
D
E
F
G
H
I
J
RF
L
M
N
O
P

POWER SUPPLY AND GROUND CIRCUIT

< DTC/CIRCUIT DIAGNOSIS >

DTC/CIRCUIT DIAGNOSIS

POWER SUPPLY AND GROUND CIRCUIT

Diagnosis Procedure

INFOID:000000009753726

SUNROOF MOTOR ASSEMBLY

1. CHECK GROUND CIRCUIT

1. Turn ignition switch OFF.
2. Disconnect sunroof motor assembly harness connector.
3. Check continuity between sunroof motor assembly harness connector and ground.

Sunroof motor assembly		Ground	Continuity
Connector	Terminal		
R11	1		Existed

Is the inspection result normal?

- YES >> GO TO 2.
NO >> Repair or replace harness or connector.

2. CHECK POWER SUPPLY CIRCUIT-I

Check voltage between sunroof motor assembly harness connector and ground.

(+)		(-)	Voltage (V) (Approx.)
Sunroof motor assembly			
Connector	Terminal		
R11	6	Ground	Battery Voltage

Is the inspection result normal?

- YES >> GO TO 4.
NO >> GO TO 3.

3. CHECK SUNROOF MOTOR CIRCUIT-I

1. Disconnect BCM harness connector.
2. Check continuity between BCM harness connector and sunroof motor assembly harness connector.

BCM		Sunroof motor assembly		Continuity
Connector	Terminal	Connector	Terminal	
M69	69	R11	6	Existed

3. Check continuity between sunroof motor assembly harness connector and ground.

Sunroof motor assembly		Ground	Continuity
Connector	Terminal		
R11	6		Not existed

Is the inspection result normal?

- YES >> Check BCM. Refer to [BCS-83. "Diagnosis Procedure"](#).
NO >> Repair or replace harness or connector.

4. CHECK POWER SUPPLY CIRCUIT-II

1. Turn ignition switch ON.
2. Check voltage between sunroof motor assembly harness connector and ground.

POWER SUPPLY AND GROUND CIRCUIT

< DTC/CIRCUIT DIAGNOSIS >

(+)		(-)	Voltage (V) (Approx.)
Sunroof motor assembly			
Connector	Terminal		
R11	3	Ground	Battery Voltage

Is the inspection result normal?

YES >> INSPECTION END

NO >> GO TO 5.

5.CHECK SUNROOF MOTOR CIRCUIT-II

1. Turn ignition switch OFF.
2. Disconnect BCM harness connector.
3. Check continuity between BCM harness connector and sunroof motor assembly harness connector.

BCM		Sunroof motor assembly		Continuity
Connector	Terminal	Connector	Terminal	
M69	68	R11	3	Existed

4. Check continuity between sunroof motor assembly harness connector and ground.

Sunroof motor assembly		Ground	Continuity
Connector	Terminal		
R11	3		Not existed

Is the inspection result normal?

YES >> Check BCM. Refer to [BCS-83. "Diagnosis Procedure"](#).

NO >> Repair or replace harness or connector.

A
B
C
D
E
F
G
H
I
J
L
M
N
O
P

RF

SUNROOF MOTOR ASSEMBLY

< DTC/CIRCUIT DIAGNOSIS >

SUNROOF MOTOR ASSEMBLY

Component Function Check

INFOID:000000009753727

1.CHECK SUNROOF MOTOR FUNCTION

Check tilt up/down & slide open/close operations with sunroof switch.

Is the inspection result normal?

YES >> GO TO 2.

NO >> Check sunroof switch. Refer to [RF-21, "Diagnosis Procedure"](#).

2.CHECK SUNROOF MOTOR ASSEMBLY INPUT SIGNAL

1. Start engine.
2. Drive the vehicle at more than 40 km/h (25 MPH).

CAUTION:

Always drive vehicle at a safe speed.

NOTE:

This procedure may be conducted with the drive wheels lifted in the shop or by driving the vehicle. If a road test is expected to be easier, it is unnecessary to lift the vehicle.

3. Check tilt up/down & slide open/close operations with sunroof switch.

Is the inspection result normal?

YES >> INSPECTION END

NO >> Refer to [RF-20, "Diagnosis Procedure"](#).

Diagnosis Procedure

INFOID:000000009753728

SUNROOF MOTOR ASSEMBLY

1.CHECK SUNROOF MOTOR ASSEMBLY INPUT SIGNAL

1. Turn ignition switch OFF.
2. Disconnect combination meter harness connector and sunroof motor assembly harness connector.
3. Check continuity between combination meter harness connector and sunroof motor assembly harness connector.

Combination meter		Sunroof motor assembly		Continuity
Connector	Terminal	Connector	Terminal	
M34	4	R11	8	Exists

4. Check continuity between sunroof motor assembly harness connector and ground.

Sunroof motor assembly		Ground	Continuity
Connector	Terminal		
R11	8		Not existed

Is the inspection result normal?

YES >> Check combination meter. Refer to [MWI-50, "COMBINATION METER : Diagnosis Procedure"](#).

NO >> Repair or replace harness or connector.

SUNROOF SWITCH

< DTC/CIRCUIT DIAGNOSIS >

SUNROOF SWITCH

Component Function Check

INFOID:000000009753729

1. CHECK SUNROOF MOTOR FUNCTION

Check tilt up/down & slide open/close operations with sunroof switch.

Is the inspection result normal?

- YES >> INSPECTION END
- NO >> Refer to [RF-21, "Diagnosis Procedure"](#).

Diagnosis Procedure

INFOID:000000009753730

1. PERFORM INITIALIZATION PROCEDURE

1. Initialization procedure is executed and operation is confirmed. Refer to [RF-17, "ADDITIONAL SERVICE WHEN REPLACING CONTROL UNIT : Special Repair Requirement"](#).
2. Check tilt up/down & slide open/close operations with sunroof switch.

Is the inspection result normal?

- YES >> INSPECTION END
- NO >> GO TO 2.

2. CHECK SUNROOF SWITCH GROUND CIRCUIT

1. Turn ignition switch OFF.
2. Disconnect sunroof switch harness connector.
3. Check continuity between sunroof switch harness connector and ground.

Sunroof switch		Ground	Continuity
Connector	Terminal		
R5	2		Existed

Is the inspection result normal?

- YES >> GO TO 3.
- NO >> Repair or replace harness or connector.

3. CHECK SUNROOF SWITCH INPUT SIGNAL

1. Turn ignition switch ON.
2. Check voltage between sunroof switch harness connector and ground.

(+)		(-)	Voltage (V) (Approx.)
sunroof switch			
Connector	Terminal	Ground	Battery Voltage
R5	1		
	3		

Is the inspection result normal?

- YES >> GO TO 5.
- NO >> GO TO 4.

4. CHECK SUNROOF SWITCH CIRCUIT

1. Turn ignition switch OFF.
2. Disconnect sunroof motor assembly harness connector.
3. Check continuity between sunroof motor assembly harness connector and sunroof switch harness connector.

SUNROOF SWITCH

< DTC/CIRCUIT DIAGNOSIS >

Sunroof motor assembly		Sunroof switch		Continuity
Connector	Terminal	Connector	Terminal	
R11	5	R5	1	Existed
	10		3	

4. Check continuity between sunroof motor assembly harness connector and ground.

Sunroof motor assembly		Ground	Continuity
Connector	Terminal		
R11	5		Not existed
	10		

Is the inspection result normal?

YES >> Replace sunroof motor assembly. Refer to [RF-37. "Removal and Installation"](#).

NO >> Repair or replace harness or connector.

5.CHECK SUNROOF SWITCH

Check sunroof switch.

Refer to [RF-22. "Component Inspection"](#).

Is the inspection result normal?

YES >> Check intermittent incident. Refer to [GI-46. "Intermittent Incident"](#).

NO >> Replace sunroof switch (built in map lamp assembly). Refer to [RF-45. "Removal and Installation"](#).

Component Inspection

INFOID:000000009753731

SUNROOF SWITCH

1.CHECK SUNROOF SWITCH

1. Turn ignition switch OFF.
2. Disconnect sunroof switch harness connector.
3. Check continuity sunroof switch terminals.

Terminals		Condition	Continuity
1	2	Sunroof switch is operated TILT DOWN or SLIDE OPEN	Existed
		Other than above	Not existed
3		Sunroof switch is operated TILT UP or SLIDE CLOSE	Existed
		Other than above	Not existed

Is the inspection result normal?

YES >> INSPECTION END

NO >> Replace sunroof switch. Refer to [RF-45. "Removal and Installation"](#).

SUNROOF DOES NOT OPERATE PROPERLY

< SYMPTOM DIAGNOSIS >

SYMPTOM DIAGNOSIS

SUNROOF DOES NOT OPERATE PROPERLY

Description

INFOID:000000009753732

Sunroof does not operate normally.

- Glass lid does not slide or tilt.
- Judder occurs during sliding operation of glass lid.
- Sliding or tilting operation of glass lid is slow.

Diagnosis Procedure

INFOID:000000009753733

1.CHECK GLASS LID

Check the following items.

- Cracks, damage, or deformation of weather-strip.
- Sticking of weather-strip.
- Loose or missing glass lid mounting blot.
- Misalignment of glass lid.

Refer to [RF-34, "Removal and Installation"](#).

Is the inspection result normal?

YES >> GO TO 2.

NO >> Repair or replace the malfunctioning parts.

2.CHECK SUNROOF FRAME ASSEMBLY

Check the following items.

- Damage, deformation or trapped foreign material of slide rail.
- Insufficient application of grease to sliding section of slide rail.

Refer to [RF-40, "Removal and Installation"](#).

Is the inspection result normal?

YES >> GO TO 3.

NO >> Repair or replace the malfunctioning parts.

3.CHECK SUNSHADE

Check sunshade for damage, deformation, of interference with other parts.

Is the inspection result normal?

YES >> GO TO 4.

NO >> Repair or replace the malfunctioning parts.

4.CHECK BCM POWER SUPPLY AND GROUND CIRCUIT

Check BCM power supply and ground circuit.

Refer to [BCS-83, "Diagnosis Procedure"](#).

Is the inspection result normal?

YES >> GO TO 5.

NO >> Repair or replace the malfunctioning parts.

5.CHECK SUNROOF MOTOR ASSEMBLY POWER SUPPLY AND GROUND CIRCUIT

Check sunroof motor assembly power supply and ground circuit.

Refer to [RF-20, "Component Function Check"](#).

Is the inspection result normal?

YES >> GO TO 6.

NO >> Repair or replace the malfunctioning parts.

6.CHECK SUNROOF SWITCH

Check sunroof switch.

Refer to [RF-21, "Component Function Check"](#).

Is the inspection result normal?

YES >> GO TO 7.

A

B

C

D

E

F

G

H

I

J

RF

L

M

N

O

P

SUNROOF DOES NOT OPERATE PROPERLY

< SYMPTOM DIAGNOSIS >

NO >> Repair or replace the malfunctioning parts.

7. CONFIRM THE OPERATION

Confirm the operation again.

Is the result normal?

YES >> Check intermittent incident. Refer to [GI-46. "Intermittent Incident"](#).

NO >> GO TO 1.

AUTO OPERATION DOES NOT OPERATE

< SYMPTOM DIAGNOSIS >

AUTO OPERATION DOES NOT OPERATE

Description

INFOID:000000009753734

Auto operation does not operate

- Auto operation of glass lid does not operate.
- Glass lid stops halfway.
- Anti-pinch function operates.

Diagnosis Procedure

INFOID:000000009753735

1.CHECK GLASS LID

Check the following items.

- Cracks, damage, or deformation of weather-strip.
- Sticking of weather-strip.
- Loose or missing glass lid mounting blot.
- Misalignment of glass lid.

Refer to [RF-34. "Removal and Installation"](#).

Is the inspection result normal?

YES >> GO TO 2.

NO >> Repair or replace the malfunctioning parts.

2.CHECK WIND DEFLECTOR

Check wind deflector for deformation and interference.

Refer to [RF-44. "Removal and Installation"](#).

Is the inspection result normal?

YES >> GO TO 3.

NO >> Repair or replace the malfunctioning parts.

3.CHECK SUNROOF FRAME ASSEMBLY

Check the following items.

- Damage, deformation or trapped foreign material of slide rail.
- Insufficient application of grease to sliding section of slide rail.

Refer to [RF-40. "Removal and Installation"](#).

Is the inspection result normal?

YES >> GO TO 4.

NO >> Repair or replace the malfunctioning parts.

4.PERFORM INITIALIZATION PROCEDURE

Perform initialization procedure.

Refer to [RF-17. "ADDITIONAL SERVICE WHEN REPLACING CONTROL UNIT : Special Repair Requirement"](#).

Is the inspection result normal?

YES >> INSPECTION END

NO >> Replace sunroof motor assembly. Refer to [RF-37. "Removal and Installation"](#).

A
B
C
D
E
F
G
H
I
J
RF
L
M
N
O
P

SUNROOF DOES NOT OPERATE ANTI-PINCH FUNCTION

< SYMPTOM DIAGNOSIS >

SUNROOF DOES NOT OPERATE ANTI-PINCH FUNCTION

Diagnosis Procedure

INFOID:000000009753736

1. PERFORM INITIALIZATION PROCEDURE

Perform initialization procedure.

Refer to [RF-17, "ADDITIONAL SERVICE WHEN REPLACING CONTROL UNIT : Special Repair Requirement"](#).

Is the inspection result normal?

YES >> Inspection end.

NO >> Check intermittent incident. Refer to [GI-46, "Intermittent Incident"](#).

RETAINED POWER OPERATION DOES NOT OPERATE PROPERLY

< SYMPTOM DIAGNOSIS >

RETAINED POWER OPERATION DOES NOT OPERATE PROPERLY

Diagnosis Procedure

INFOID:000000009753737

1.CHECK DOOR SWITCH

Check door switch.

Refer to [DLK-81, "Component Function Check"](#).

Is the inspection result normal?

YES >> GO TO 2.

NO >> Repair or replace the malfunctioning parts.

2.CHECK SUNROOF MOTOR ASSEMBLY POWER SUPPLY AND GROUND

Check sunroof motor assembly power supply and ground circuit.

Refer to [RF-20, "Component Function Check"](#).

Is the inspection result normal?

YES >> GO TO 3.

NO >> Repair or replace the malfunctioning parts.

3.REPLACE BCM

- Replace BCM. Refer to [BCS-90, "Removal and Installation"](#) (with Intelligent Key) or [BCS-157, "Removal and Installation"](#) (without Intelligent Key).
- Confirm the operation after replacement.

Is the result normal?

YES >> INSPECTION END

NO >> Check intermittent incident. Refer to [GI-46, "Intermittent Incident"](#).

A
B
C
D
E
F
G
H
I
J
RF
L
M
N
O
P

SQUEAK AND RATTLE TROUBLE DIAGNOSES

< SYMPTOM DIAGNOSIS >

SQUEAK AND RATTLE TROUBLE DIAGNOSES

Work Flow

INFOID:000000009753738

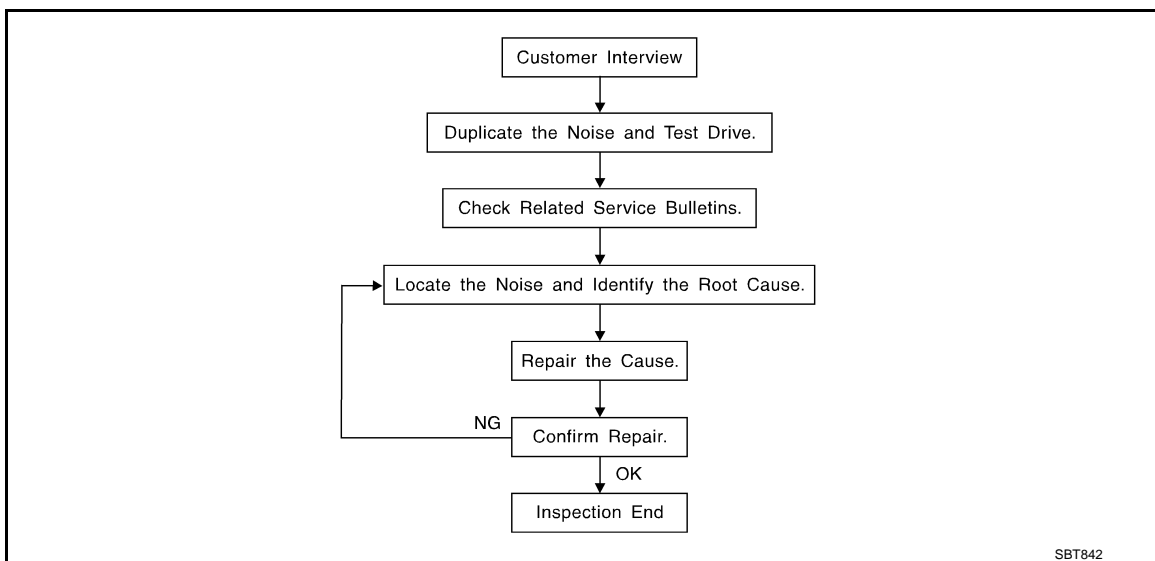

CUSTOMER INTERVIEW

Interview the customer if possible, to determine the conditions that exist when the noise occurs. Use the Diagnostic Worksheet during the interview to document the facts and conditions when the noise occurs and any customer comments. Refer to [RF-32, "Diagnostic Worksheet"](#). This information is necessary to duplicate the conditions that exist when the noise occurs.

- The customer may not be able to provide a detailed description or the location of the noise. Attempt to obtain all the facts and conditions that exist when the noise occurs (or does not occur).
- If there is more than one noise in the vehicle, perform a diagnosis and repair the noise that the customer is concerned about. This can be accomplished by performing a test drive with the customer.
- After identifying the type of noise, isolate the noise in terms of its characteristics. The noise characteristics are provided so that the customer, service adviser, and technician use the same language when describing the noise.
- Squeak – (Like tennis shoes on a clean floor)
Squeak characteristics include the light contact / fast movement / brought on by road conditions / hard surfaces = high-pitched noise / softer surfaces = low-pitched noises / edge to surface = chirping
- Creak – (Like walking on an old wooden floor)
Creak characteristics include firm contact / slow movement/twisting with a rotational movement / pitch dependent on materials / often brought on by activity.
- Rattle – (Like shaking a baby rattle)
Rattle characteristics include fast repeated contact / vibration or similar movement / loose parts/missing clip or fastener / incorrect clearance.
- Knock – (Like a knock on a door)
Knock characteristics include hollow sounds / sometimes repeating / often brought on by driver action.
- Tick – (Like a clock second hand)
Tick characteristics include gentle contacting of light materials / loose components / can be caused by driver action or road conditions.
- Thump – (Heavy, muffled knock noise)
Thump characteristics include softer knock / dull sounds often brought on by activity.
- Buzz – (Like a bumblebee)
Buzz characteristics include high frequency rattle / firm contact.
- Often the degree of acceptable noise level varies depending upon the person. A noise that a technician may judge as acceptable may be very irritating to a customer.
- Weather conditions, especially humidity and temperature, may have a great effect on noise level.

DUPLICATE THE NOISE AND TEST DRIVE

If possible, drive the vehicle with the customer until the noise is duplicated. Note any additional information on the Diagnostic Worksheet regarding the conditions or location of the noise. This information can be used to duplicate the same conditions when the repair is reconfirmed.

SQUEAK AND RATTLE TROUBLE DIAGNOSES

< SYMPTOM DIAGNOSIS >

If the noise can be duplicated easily during the test drive, to help identify the source of the noise, try to duplicate the noise with the vehicle stopped by doing one or all of the following items:

- 1) Close a door.
 - 2) Tap or push/pull around the area where the noise appears to be coming from.
 - 3) Rev the engine.
 - 4) Use a floor jack to recreate vehicle "twist".
 - 5) At idle, apply engine load (electrical load, half-clutch on M/T models, drive position on A/T models).
 - 6) Raise the vehicle on a hoist and hit a tire with a rubber hammer.
- Drive the vehicle and attempt to duplicate the conditions the customer states exist when the noise occurs.
 - If it is difficult to duplicate the noise, drive the vehicle slowly on an undulating or rough road to stress the vehicle body.

CHECK RELATED SERVICE BULLETINS

After verifying the customer concern or symptom, check ASIST for Technical Service Bulletins (TSBs) related to the concern or symptom.

If a TSB relates to the symptom, follow the procedure to repair the noise.

LOCATE THE NOISE AND IDENTIFY THE ROOT CAUSE

1. Narrow down the noise to a general area. To help pinpoint the source of the noise, use a listening tool (Chassis ear: J-39570, engine ear, and mechanics stethoscope).
2. Narrow down the noise to a more specific area and identify the cause of the noise by:
 - Removing the component(s) in the area that is / are suspected to be the cause of the noise. Do not use too much force when removing clips and fasteners, otherwise clips and fasteners can be broken or lost during the repair, resulting in the creation of new noise.
 - Tapping or pushing/pulling the component(s) that is / are suspected to be the cause of the noise. Do not tap or push/pull the component(s) with excessive force, otherwise the noise is eliminated only temporarily.
 - Feeling for a vibration by hand by touching the component(s) that is / are suspected to be the cause of the noise.
 - Placing a piece of paper between components that are suspected to be the cause of the noise.
 - Looking for loose components and contact marks.
Refer to [RF-30. "Inspection Procedure"](#).

REPAIR THE CAUSE

- If the cause is a loose component, tighten the component securely.
- If the cause is insufficient clearance between components:
 - Separate components by repositioning or loosening and retightening the components, if possible.
 - Insulate components with a suitable insulator such as urethane pads, foam blocks, felt cloth tape, or urethane tape. A NISSAN Squeak and Rattle Kit (J-50397) is available through the authorized NISSAN Parts Department.

CAUTION:

Never use excessive force as many components are constructed of plastic and may be damaged.

NOTE:

Always check with the Parts Department for the latest parts information.

The following materials are contained in the NISSAN Squeak and Rattle Kit (J-50397) are listed on the inside cover of the kit; and can each be ordered separately as needed.

URETHANE PADS [1.5 mm (0.059 in) thick]

Insulates connectors, harness, etc.

- 76268-9E005: 100 × 135 mm (3.937 × 5.315 in)
- 76884-71L01: 60 × 85 mm (2.362 × 3.346 in)
- 76884-71L02: 15 × 25 mm (0.591 × 0.984 in)

INSULATOR (Foam blocks)

Insulates components from contact. Can be used to fill space behind a panel.

- 73982-9E000: 45 mm (1.772 in) thick, 50 × 50 mm (1.969 × 1.969 in)
- 73982-50Y00: 10 mm (0.394 in) thick, 50 × 50 mm (1.969 × 1.969 in)

INSULATOR (Light foam block)

80845-71L00: 30 mm (1.181 in) thick, 30 × 50 mm (1.181 × 1.969 in)

FELT CLOTHTAPE

Used to insulate where movement does not occur. Ideal for instrument panel applications.

- 68370-4B000: 15 × 25 mm (0.591 × 0.984 in) pad
- 68239-13E00: 5 mm (0.197 in) wide tape roll

SQUEAK AND RATTLE TROUBLE DIAGNOSES

< SYMPTOM DIAGNOSIS >

The following materials, not found in the kit, can also be used to repair squeaks and rattles.

UHMW (TEFLON) TAPE

Insulates where slight movement is present. Ideal for instrument panel applications.

SILICONE GREASE

Used in place of UHMW tape that is visible or does not fit. Only lasts a few months.

SILICONE SPRAY

Used when grease cannot be applied.

DUCT TAPE

Used to eliminate movement.

CONFIRM THE REPAIR

After repair is complete, test drive the vehicle to confirm that the cause of noise is repaired by test driving the vehicle. Operate the vehicle under the same conditions as when the noise originally occurred. Refer to the notes on the Diagnostic Worksheet.

Inspection Procedure

INFOID:000000009753739

Refer to Table of Contents for specific component removal and installation information.

INSTRUMENT PANEL

Most incidents are caused by contact and movement between:

1. The cluster lid A and instrument panel
2. Acrylic lens and combination meter housing
3. Instrument panel to front pillar garnish
4. Instrument panel to windshield
5. Instrument panel mounting pins
6. Wiring harnesses behind the combination meter
7. A/C defroster duct and duct joint

These incidents can usually be located by tapping or moving the components to duplicate the noise or by pressing on the components while driving to stop the noise. Most of these incidents can be repaired by applying felt cloth tape or silicon spray (in hard to reach areas). Urethane pads can be used to insulate wiring harness.

CAUTION:

Never use silicone spray to isolate a squeak or rattle. If the area is saturated with silicone, the recheck of repair becomes impossible.

CENTER CONSOLE

Components to check include:

1. Shifter assembly cover to finisher
2. A/C control unit and cluster lid C
3. Wiring harnesses behind audio and A/C control unit

The instrument panel repair and isolation procedures also apply to the center console.

DOORS

Check the following items:

1. Finisher and inner panel making a slapping noise
2. Inside handle escutcheon connection to door finisher
3. Wiring harnesses tapping
4. Door striker out of alignment causing a popping noise on starts and stops

Tapping, moving the components, or pressing on them while driving to duplicate the conditions can isolate many of these incidents. The areas can usually be insulated with felt cloth tape or insulator foam blocks from the NISSAN Squeak and Rattle Kit (J-50397) to repair the noise.

TRUNK

Trunk noises are often caused by a loose jack or loose items put into the trunk by the customer.

In addition check for the following items:

1. Trunk lid dumpers out of adjustment
2. Trunk lid striker out of adjustment

SQUEAK AND RATTLE TROUBLE DIAGNOSES

< SYMPTOM DIAGNOSIS >

3. Trunk lid torsion bars knocking together
4. A loose license plate or bracket

Most of these incidents can be repaired by adjusting, securing, or insulating the item(s) or component(s) causing the noise.

SUNROOF/HEADLINING

Noises in the sunroof / headlining area can often be traced to one of the following items:

1. Sunroof lid, rail, linkage, or seals making a rattle or light knocking noise
2. Sunvisor shaft shaking in the holder
3. Front or rear windshield touching headlining and squeaking

Again, pressing on the components to stop the noise while duplicating the conditions can isolate most of these incidents. Repairs usually consist of insulating with felt cloth tape.

SEATS

When isolating seat noise it is important to note the position the seat is in and the load placed on the seat when the noise occurs. These conditions should be duplicated when verifying and isolating the cause of the noise.

Causes of seat noise include:

1. Headrest rods and holder
2. A squeak between the seat pad cushion and frame
3. The rear seatback lock and bracket

These noises can be isolated by moving or pressing on the suspected components while duplicating the conditions under which the noise occurs. Most of these incidents can be repaired by repositioning the component or applying urethane tape to the contact area.

UNDERHOOD

Some interior noise may be caused by components under the hood or on the engine wall. The noise is then transmitted into the passenger compartment.

Causes of transmitted underhood noise include:

1. Any component mounted to the engine wall
2. Components that pass through the engine wall
3. Engine wall mounts and connectors
4. Loose radiator mounting pins
5. Hood bumpers out of adjustment
6. Hood striker out of adjustment

These noises can be difficult to isolate since they cannot be reached from the interior of the vehicle. The best method is to secure, move, or insulate one component at a time and test drive the vehicle. Also, engine RPM or load can be changed to isolate the noise. Repairs can usually be made by moving, adjusting, securing, or insulating the component causing the noise.

A
B
C
D
E
F
G
H
I
J
RF
L
M
N
O
P

SQUEAK AND RATTLE TROUBLE DIAGNOSES

< SYMPTOM DIAGNOSIS >

Diagnostic Worksheet

INFOID:00000009753740



SQUEAK & RATTLE DIAGNOSTIC WORKSHEET

Dear Nissan Customer:

We are concerned about your satisfaction with your Nissan vehicle. Repairing a squeak or rattle sometimes can be very difficult. To help us fix your Nissan right the first time, please take a moment to note the area of the vehicle where the squeak or rattle occurs and under what conditions. You may be asked to take a test drive with a service advisor or technician to ensure we confirm the noise you are hearing.

I. WHERE DOES THE NOISE COME FROM? (circle the area of the vehicle)

The illustrations are for reference only, and may not reflect the actual configuration of your vehicle.

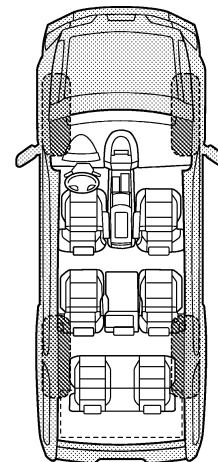
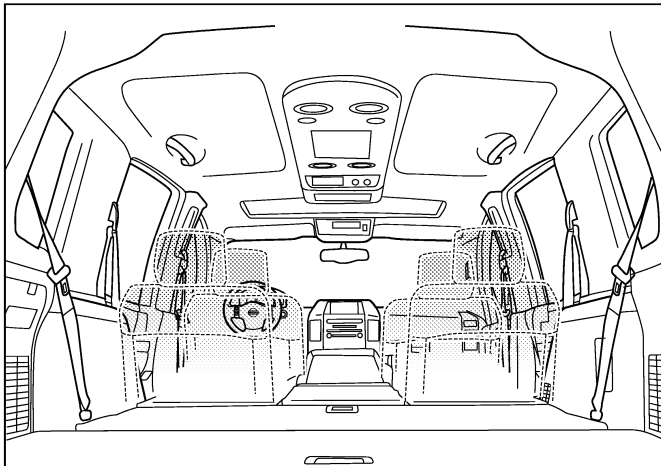
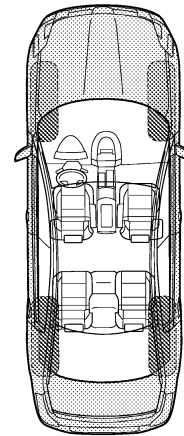
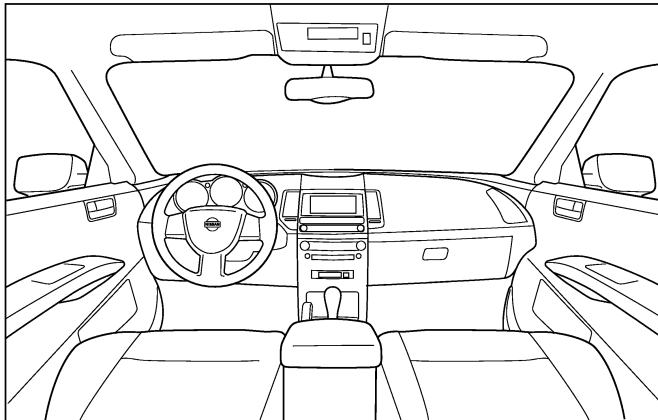

Continue to page 2 of the worksheet and briefly describe the location of the noise or rattle. In addition, please indicate the conditions which are present when the noise occurs.

PIIB8740E

SQUEAK AND RATTLE TROUBLE DIAGNOSES

< SYMPTOM DIAGNOSIS >

SQUEAK & RATTLE DIAGNOSTIC WORKSHEET - page 2

Briefly describe the location where the noise occurs:

II. WHEN DOES IT OCCUR? (please check the boxes that apply)

- | | |
|---|--|
| <input type="checkbox"/> anytime | <input type="checkbox"/> after sitting out in the rain |
| <input type="checkbox"/> 1st time in the morning | <input type="checkbox"/> when it is raining or wet |
| <input type="checkbox"/> only when it is cold outside | <input type="checkbox"/> dry or dusty conditions |
| <input type="checkbox"/> only when it is hot outside | <input type="checkbox"/> other: |

III. WHEN DRIVING:

- through driveways
- over rough roads
- over speed bumps
- only about ____ mph
- on acceleration
- coming to a stop
- on turns: left, right or either (circle)
- with passengers or cargo
- other: _____
- after driving ____ miles or ____ minutes

IV. WHAT TYPE OF NOISE

- squeak (like tennis shoes on a clean floor)
- creak (like walking on an old wooden floor)
- rattle (like shaking a baby rattle)
- knock (like a knock at the door)
- tick (like a clock second hand)
- thump (heavy, muffled knock noise)
- buzz (like a bumble bee)

TO BE COMPLETED BY DEALERSHIP PERSONNEL

Test Drive Notes:

	YES	NO	Initials of person performing
Vehicle test driven with customer	<input type="checkbox"/>	<input type="checkbox"/>	_____
- Noise verified on test drive	<input type="checkbox"/>	<input type="checkbox"/>	_____
- Noise source located and repaired	<input type="checkbox"/>	<input type="checkbox"/>	_____
- Follow up test drive performed to confirm repair	<input type="checkbox"/>	<input type="checkbox"/>	_____

VIN: _____ Customer Name: _____
 W.O.# _____ Date: _____

This form must be attached to Work Order

PIIB8742E

A
B
C
D
E
F
G
H
I
J
RF
L
M
N
O
P

GLASS LID

< REMOVAL AND INSTALLATION >

REMOVAL AND INSTALLATION

GLASS LID

Exploded View

INFOID:000000009753741

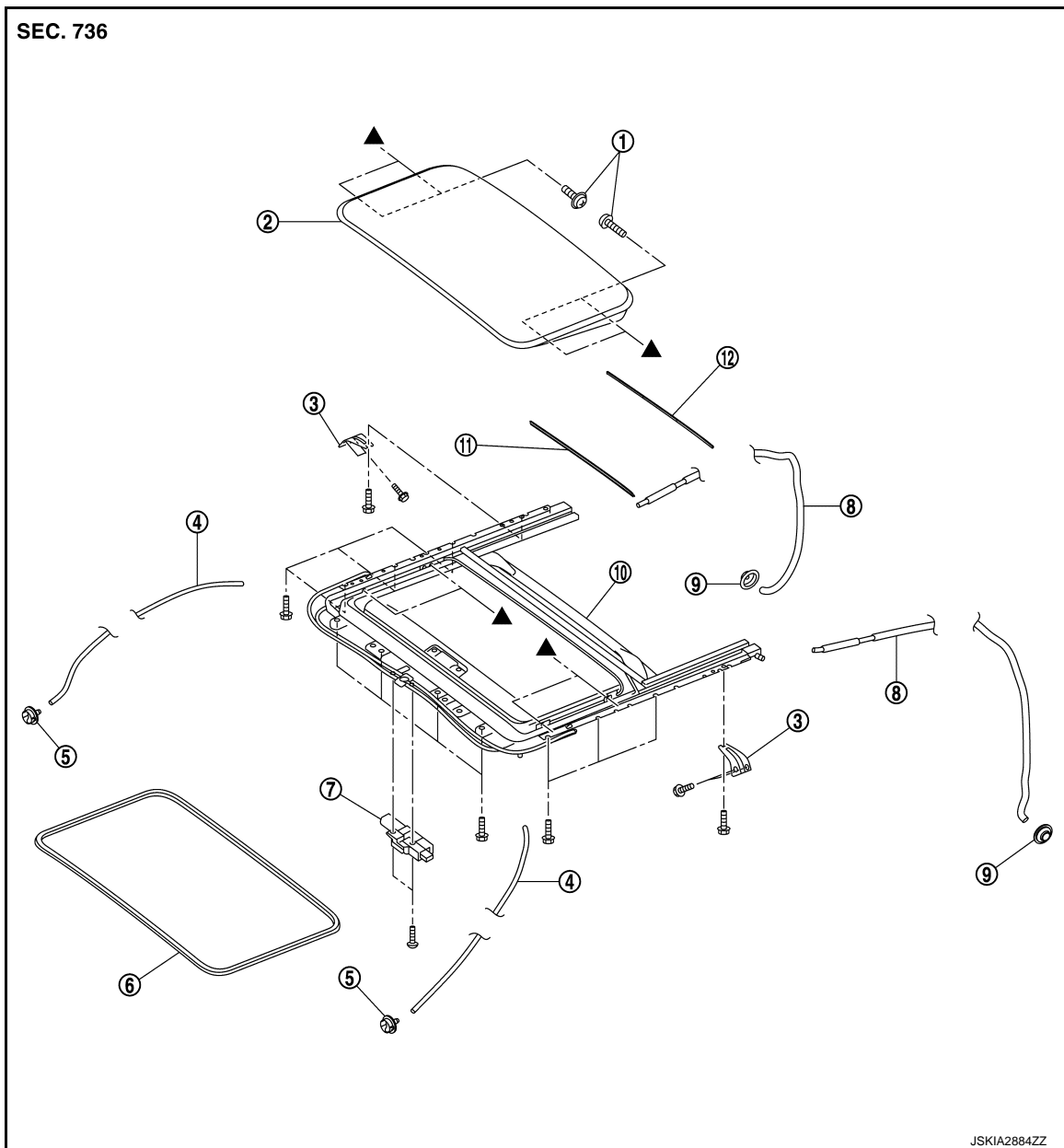

- | | | |
|---------------------------|----------------------------|---------------------------|
| 1. TORX bolt | 2. Glass lid | 3. Sunroof bracket |
| 4. Drain hose (front) | 5. Drain connector (front) | 6. Sunroof welt |
| 7. Sunroof motor assembly | 8. Drain hose (rear) | 9. Drain connector (rear) |
| 10. Sunroof unit assembly | 11. Seal guide rubber | 12. Seal sunroof |

▲ : Indicates that the part is connected at points with same symbol in actual vehicle.

Removal and Installation

INFOID:000000009753742

REMOVAL

CAUTION:

- Always work with a helper.

GLASS LID

< REMOVAL AND INSTALLATION >

• Fully close the glass lid, before removal, then never operate sunroof motor after removal.

1. Remove glass lid mounting TORX bolts (A).

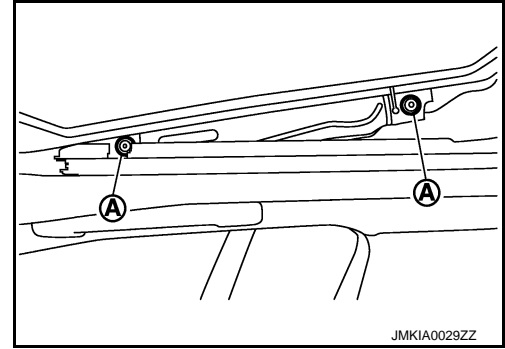

2. Remove glass lid from vehicle.

INSTALLATION

Note the following items, and then install in the reverse order of removal.

CAUTION:

After installing the glass lid, perform the leak test and check that there is no malfunction.

NOTE:

After installation carry out fitting adjustment. Refer to [RF-35, "Adjustment"](#).

Adjustment

INFOID:000000009753743

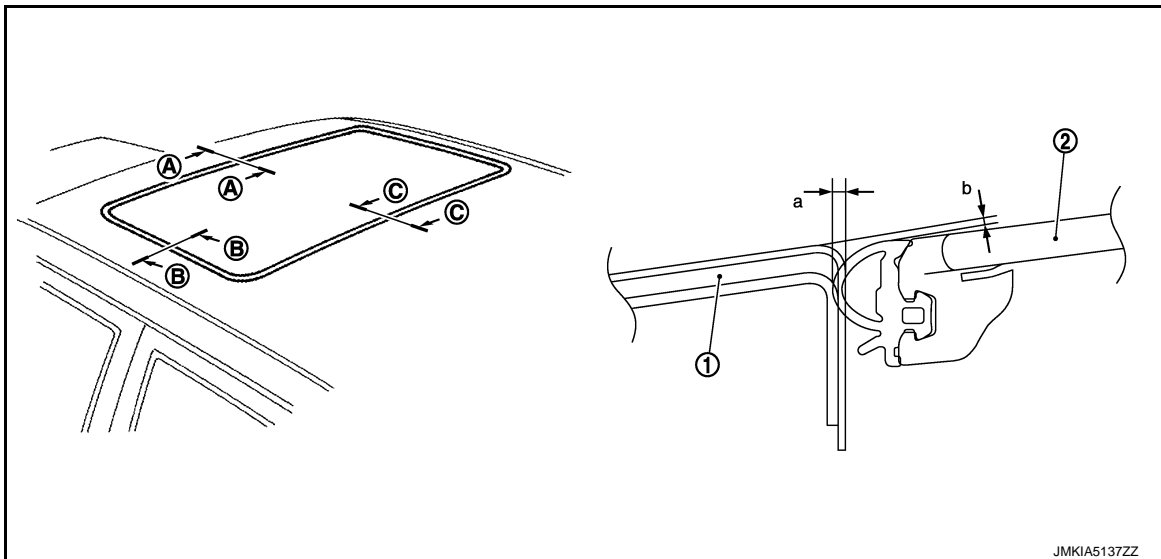

1. Roof panel
2. Glass lid

If the clearance and the surface height are out of specification, adjust them according to the procedures shown below.

Portion	a (Clearance)	b (Surface height difference)
A - A	0.6 - 2.2 mm (0.024 - 0.087 in)	(-0.7) - (+2.3) mm [(-0.028) - (+0.091) in]
B - B	0.6 - 2.2 mm (0.024 - 0.087 in)	(-0.7) - (+2.3) mm [(-0.028) - (+0.091) in]
C - C	0.6 - 2.2 mm (0.024 - 0.087 in)	(-0.7) - (+2.3) mm [(-0.028) - (+0.091) in]

1. Loosen glass lid mounting TORX bolts.
2. Adjust the clearance of glass lid and roof panel according to the fitting standard dimension.
3. To prevent glass lid from moving after adjustment, first tighten the TORX bolts of front left, and then tighten the TORX bolts of rear right.
4. Tilt glass lid up and down several times to check that it moves smoothly.

NOTE:

GLASS LID

< REMOVAL AND INSTALLATION >

After adjustment the sunroof unit assembly, perform additional service. Refer to [RF-17, "ADDITIONAL SERVICE WHEN REPLACING CONTROL UNIT : Special Repair Requirement"](#).

SUNROOF MOTOR ASSEMBLY

< REMOVAL AND INSTALLATION >

SUNROOF MOTOR ASSEMBLY

Exploded View

INFOID:000000009753744

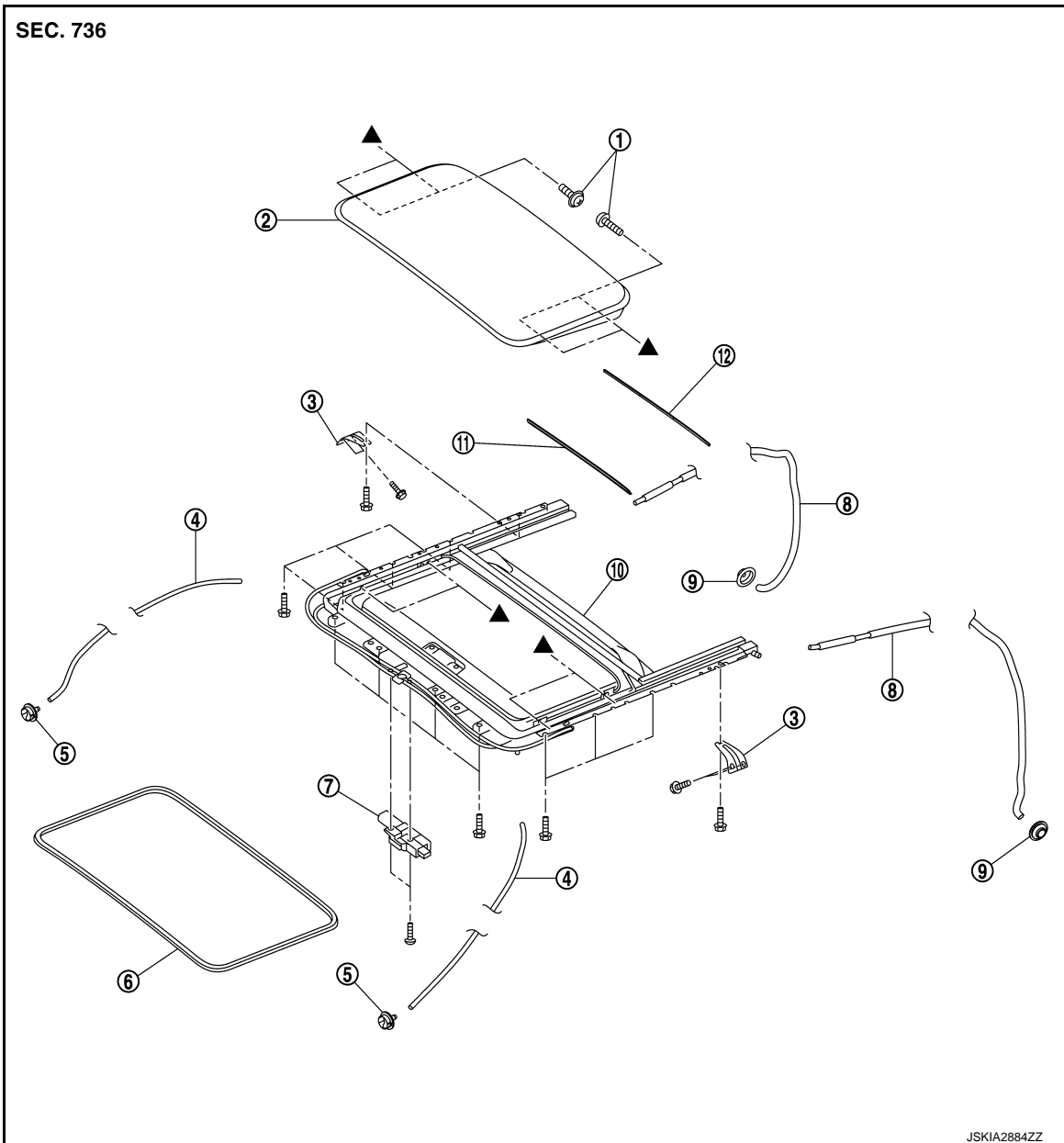

- | | | |
|---------------------------|----------------------------|---------------------------|
| 1. TORX bolt | 2. Glass lid | 3. Sunroof bracket |
| 4. Drain hose (front) | 5. Drain connector (front) | 6. Sunroof welt |
| 7. Sunroof motor assembly | 8. Drain hose (rear) | 9. Drain connector (rear) |
| 10. Sunroof unit assembly | 11. Seal guide rubber | 12. Seal sunroof |

▲ : Indicates that the part is connected at points with same symbol in actual vehicle.

Removal and Installation

INFOID:000000009753745

REMOVAL

CAUTION:

- Before removing sunroof motor, check that glass lid is fully closed.
- After removing sunroof motor, never attempt to rotate sunroof motor assembly as a single unit.

1. Fully close glass lid.

A
B
C
D
E
F
G
H
I
J
RF
L
M
N
O
P

SUNROOF MOTOR ASSEMBLY

< REMOVAL AND INSTALLATION >

2. Remove headlining. Refer to [INT-30, "SUNROOF : Removal and Installation"](#).
3. Remove sunroof motor.
 1. Disconnect harness connector (A) from sunroof motor.
 2. Remove sunroof motor assembly fixing screws (B), and then remove sunroof motor assembly.

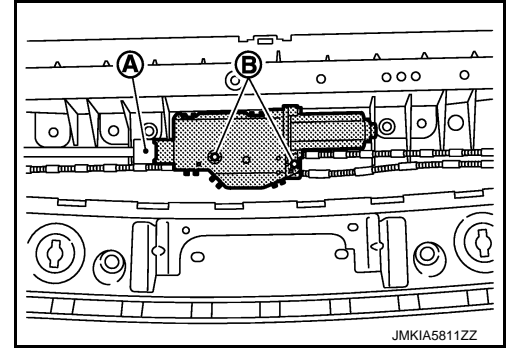

INSTALLATION

CAUTION:

Before installing the sunroof motor assembly, be sure to place the link and wire assembly in the symmetrical and fully closed position.

1. Move the sunroof motor assembly laterally by little so that the gear is completely engaged into the wire on the sunroof unit assembly and mounting surface becomes parallel. Then secure the sunroof motor assembly with screws.
2. Install headlining.

NOTE:

After installation sunroof motor, perform additional service. Refer to [RF-17, "ADDITIONAL SERVICE WHEN REPLACING CONTROL UNIT : Description"](#).

SUNROOF UNIT ASSEMBLY

< REMOVAL AND INSTALLATION >

SUNROOF UNIT ASSEMBLY

Exploded View

INFOID:000000009753746

REMOVAL

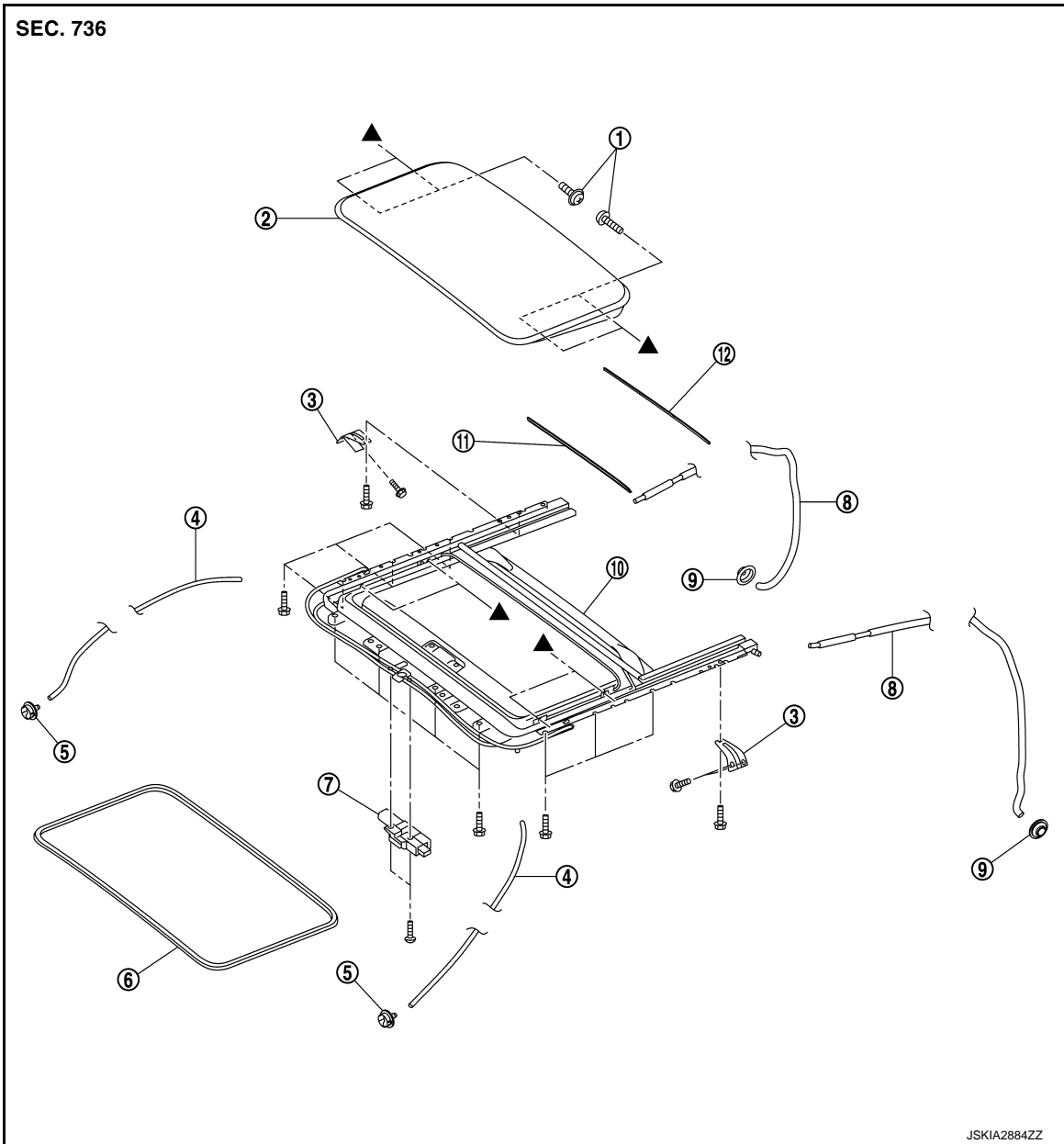

- | | | |
|---------------------------|----------------------------|---------------------------|
| 1. TORX bolt | 2. Glass lid | 3. Sunroof bracket |
| 4. Drain hose (front) | 5. Drain connector (front) | 6. Sunroof welt |
| 7. Sunroof motor assembly | 8. Drain hose (rear) | 9. Drain connector (rear) |
| 10. Sunroof unit assembly | 11. Seal guide rubber | 12. Seal sunroof |

▲ : Indicates that the part is connected at points with same symbol in actual vehicle.

DISASSEMBLY

A
B
C
D
E
F
G
H
I
J
RF
L
M
N
O
P

SUNROOF UNIT ASSEMBLY

< REMOVAL AND INSTALLATION >

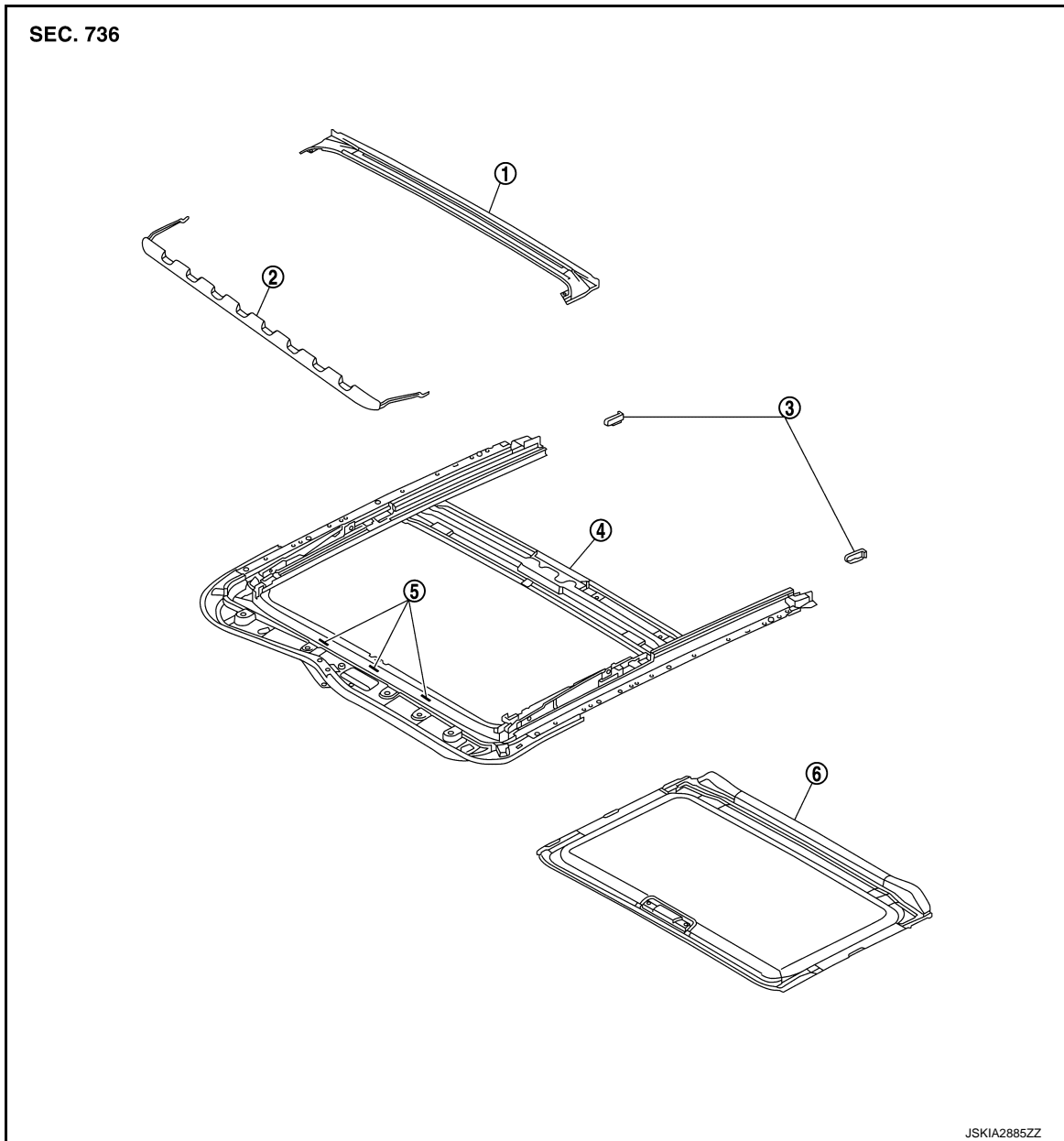

- | | | |
|---------------------------|----------------------|---------------------|
| 1. Rear drain assembly | 2. Wind deflector | 3. Sunshade stopper |
| 4. Sunroof frame assembly | 5. Seating deflector | 6. Sunshade |

Removal and Installation

INFOID:000000009753747

REMOVAL

CAUTION:

- Always work with a helper.
- Fully close the glass lid assembly, before removal, then never operate sunroof motor assembly after removal.
- After removing sunroof motor, never attempt to rotate sunroof motor assembly as a single unit.
- When remove/install sunroof unit, use cloths to protect the seats and trim from damage.
- After installing the sunroof unit and glass lid, perform the leak test and check that there is no malfunction.

1. Remove glass lid. Refer to [RF-34, "Removal and Installation"](#).
2. Remove headlining. Refer to [INT-30, "SUNROOF : Removal and Installation"](#).
3. Disconnect drain hoses.

SUNROOF UNIT ASSEMBLY

< REMOVAL AND INSTALLATION >

4. Remove sunroof brackets mounting bolts, and then remove sunroof brackets. A
5. Remove bolts from the front end and side rail, and then remove sunroof unit assembly from roof panel. B
6. Remove sunroof unit assembly through the passenger compartment while being careful not to damage the seats and trim. C

INSTALLATION

1. Temporarily tighten the mounting bolts to the both side of sunroof unit assembly. D
2. Temporarily tighten the mounting bolts to the front end of sunroof unit assembly. E
3. Temporarily tighten the mounting bolts to the sunroof brackets (LH and RH). F
4. Tighten the installation points diagonally excluding the installation points of the sunroof brackets around the roof opening. G
5. Tighten the sunroof bracket bolts of the vehicle side, and then tighten the bolt of the sunroof unit assembly side. H
6. Tighten the mounting bolts to the front end and both side of sunroof unit assembly. I
7. Connect drain hoses. J
8. Install headlining. Refer to [INT-30, "SUNROOF : Removal and Installation"](#). RF
9. Install glass lid. Refer to [RF-34, "Removal and Installation"](#). G
10. Install side trims. H

NOTE:

- After installation, perform fitting adjustment. Refer to [RF-35, "Adjustment"](#). I
- After installation sunroof unit assembly, perform additional service. Refer to [RF-17, "ADDITIONAL SERVICE WHEN REPLACING CONTROL UNIT : Description"](#). J

Disassembly and Assembly

INFOID:000000009753748

DISASSEMBLY

1. Remove sunshade stopper mounting from the rear end of sunroof frame. I
2. Remove sunshade from the rear end of sunroof frame. J
3. Remove rear drain assembly from sunroof guide assembly. RF

ASSEMBLY

Assemble in the reverse order of disassembly.

RF

L

M

N

O

P

SUNSHADE

< REMOVAL AND INSTALLATION >

SUNSHADE

Exploded View

INFOID:000000009753749

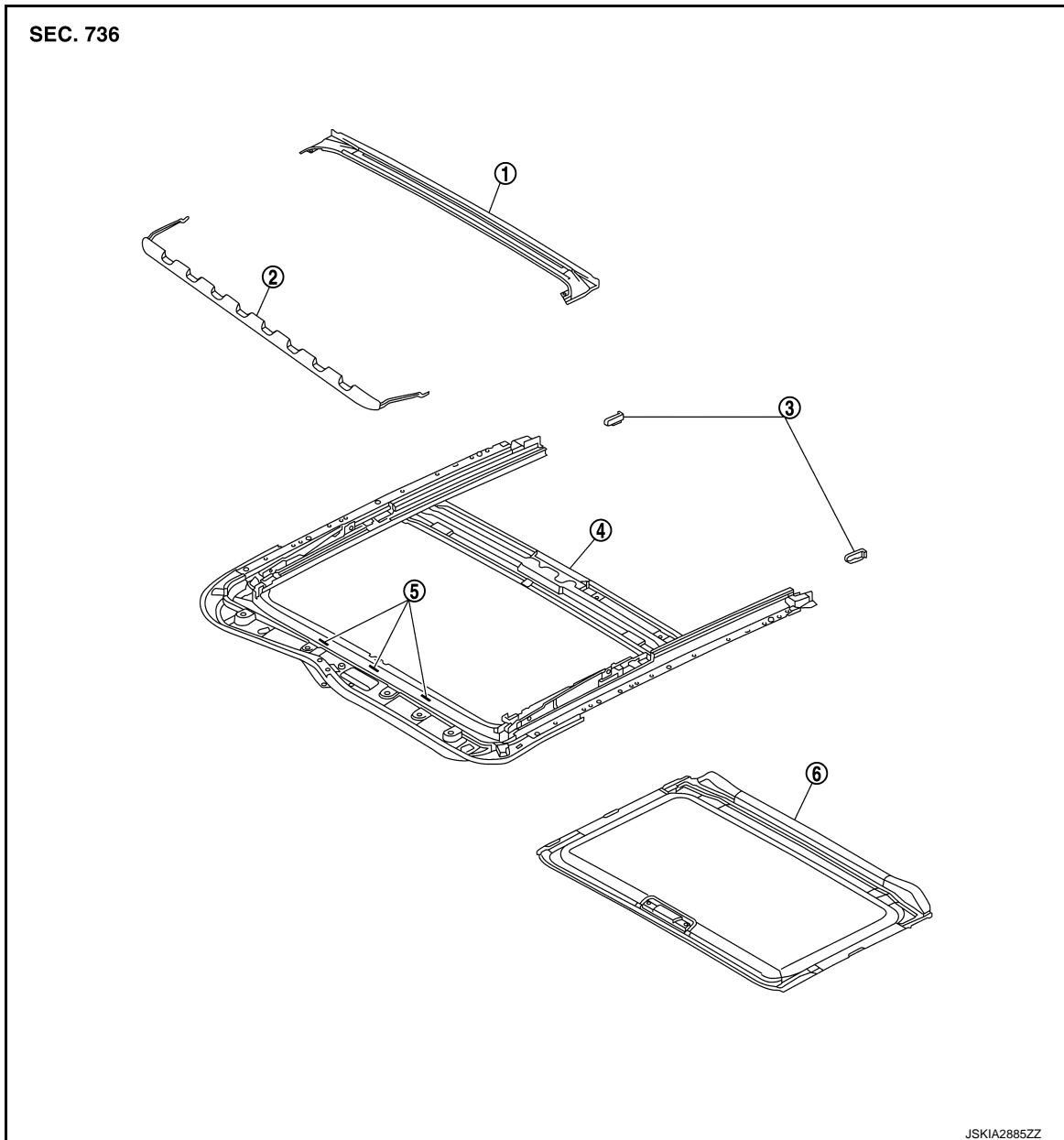

- | | | |
|---------------------------|----------------------|---------------------|
| 1. Rear drain assembly | 2. Wind deflector | 3. Sunshade stopper |
| 4. Sunroof frame assembly | 5. Seating deflector | 6. Sunshade |

Removal and Installation

INFOID:000000009753750

REMOVAL

1. Remove headlining. Refer to [INT-30. "SUNROOF : Removal and Installation"](#).

SUNSHADE

< REMOVAL AND INSTALLATION >

2. Remove the sunshade stopper (1) from the rear end of sunroof frame.
3. Remove the sunshade from the rear end of sunroof frame.

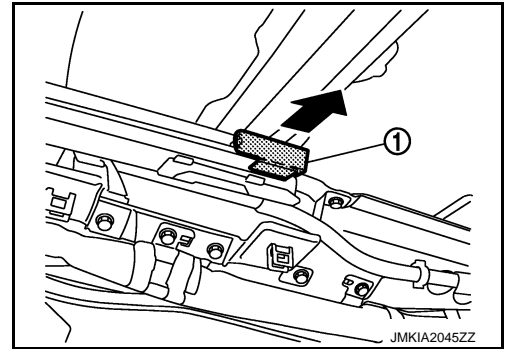

INSTALLATION

Install in the reverse order of removal.

A
B
C
D
E
F
G
H
I
J
RF
L
M
N
O
P

WIND DEFLECTOR

< REMOVAL AND INSTALLATION >

WIND DEFLECTOR

Exploded View

INFOID:000000009753751

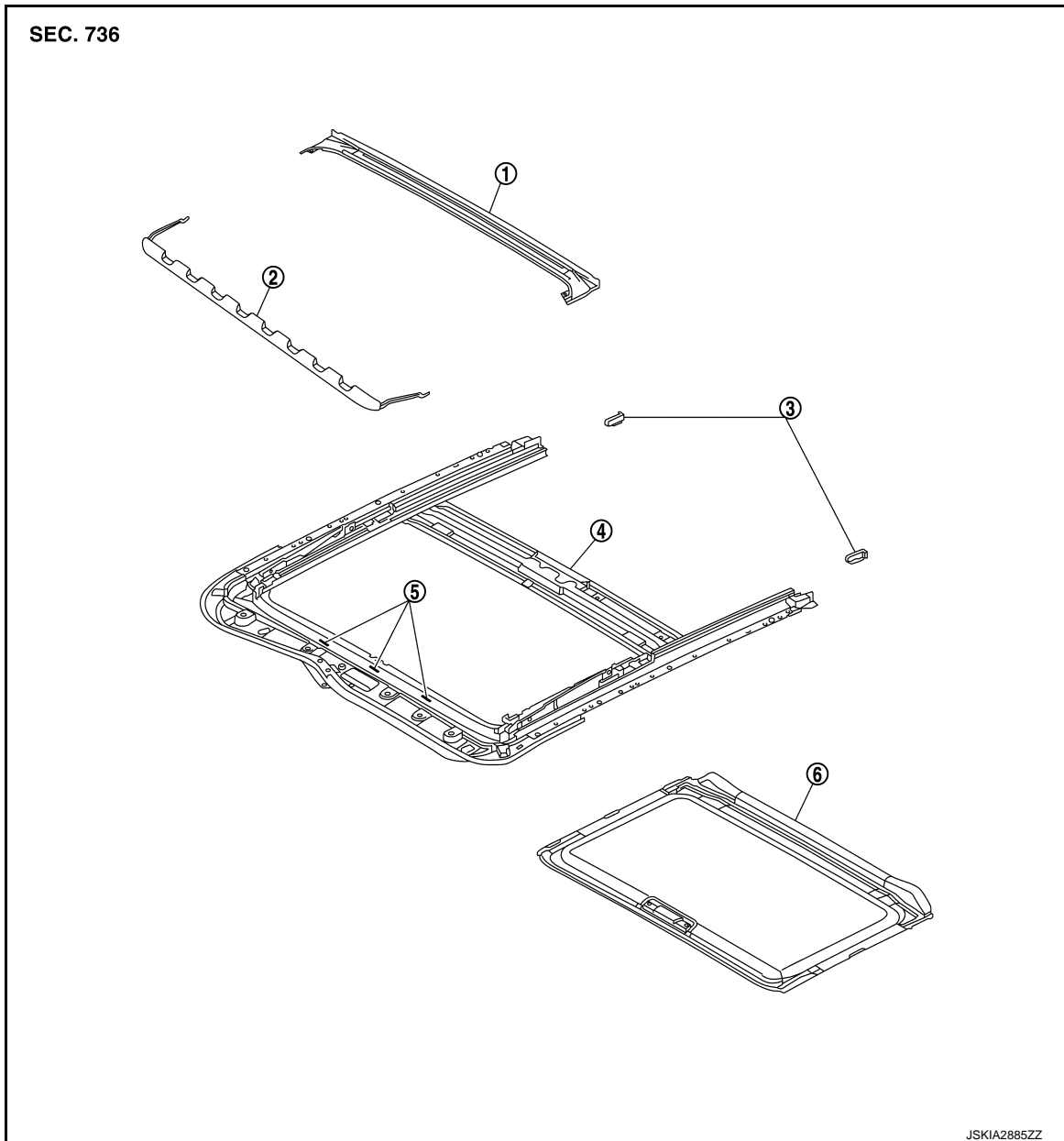

- | | | |
|---------------------------|----------------------|---------------------|
| 1. Rear drain assembly | 2. Wind deflector | 3. Sunshade stopper |
| 4. Sunroof frame assembly | 5. Seating deflector | 6. Sunshade |

Removal and Installation

INFOID:000000009753752

REMOVAL

1. Open the glass lid to see the wind deflector installation point on the sun roof slide rail.
2. Remove the wind deflector.
 1. Remove the spring from sunroof frame groove.
 2. Turn the wind deflector and remove it from sunroof frame.

INSTALLATION

Install in the reverse order of removal.

SUNROOF SWITCH

< REMOVAL AND INSTALLATION >

SUNROOF SWITCH

Removal and Installation

INFOID:000000009753753

REMOVAL

1. Remove headlining. Refer to [INT-30. "SUNROOF : Removal and Installation"](#).
2. Remove sun roof switch (1) from map lamp switch finisher (2) using remover tool (A).

 : Pawl

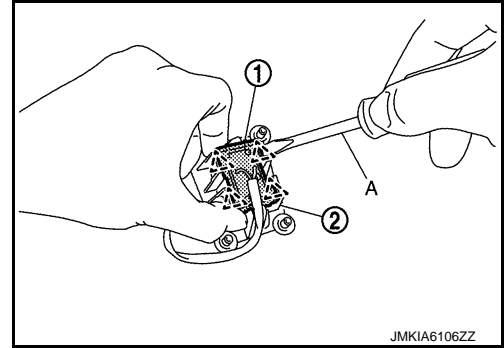

INSTALLATION

Install in the reverse order of removal.

A
B
C
D
E
F
G
H
I
J
RF
L
M
N
O
P