

SECTION **RSU**  
 REAR SUSPENSION

A  
B  
C  
D

RSU

CONTENTS

<b>2WD</b>	Inspection .....15	F
<b>PRECAUTION</b> ..... 3	<b>SERVICE DATA AND SPECIFICATIONS (SDS)</b> .....16	G
<b>PRECAUTIONS</b> ..... 3	<b>SERVICE DATA AND SPECIFICATIONS (SDS)</b> .....16	H
Precautions for Suspension .....3	Wheel Alignment .....16	I
Precautions for Removing of Battery Terminal .....3	Wheelarch Height .....16	J
<b>PREPARATION</b> ..... 4	<b>AWD</b>	K
<b>PREPARATION</b> ..... 4	<b>PRECAUTION</b> .....18	L
Commercial Service Tools .....4	<b>PRECAUTIONS</b> .....18	M
<b>SYMPTOM DIAGNOSIS</b> ..... 5	Precautions for Suspension .....18	N
<b>NOISE, VIBRATION AND HARSHNESS (NVH) TROUBLESHOOTING</b> ..... 5	Precautions for Removing of Battery Terminal .....18	O
NVH Troubleshooting Chart .....5	<b>PREPARATION</b> .....19	P
<b>PERIODIC MAINTENANCE</b> ..... 6	<b>PREPARATION</b> .....19	
<b>REAR SUSPENSION ASSEMBLY</b> ..... 6	Commercial Service Tools .....19	
Inspection .....6	<b>SYMPTOM DIAGNOSIS</b> .....20	
<b>WHEEL ALIGNMENT</b> ..... 7	<b>NOISE, VIBRATION AND HARSHNESS (NVH) TROUBLESHOOTING</b> .....20	
Inspection .....7	NVH Troubleshooting Chart .....20	
<b>REMOVAL AND INSTALLATION</b> ..... 8	<b>PERIODIC MAINTENANCE</b> .....21	
<b>REAR SHOCK ABSORBER</b> ..... 8	<b>REAR SUSPENSION ASSEMBLY</b> .....21	
Exploded View .....8	Inspection .....21	
Removal and Installation .....9	<b>WHEEL ALIGNMENT</b> .....22	
Inspection .....10	Inspection .....22	
Disposal .....10	Adjustment .....22	
<b>COIL SPRING</b> .....12	<b>REMOVAL AND INSTALLATION</b> .....24	
Exploded View .....12	<b>REAR SHOCK ABSORBER</b> .....24	
Removal and Installation .....12	Exploded View .....24	
Inspection .....13	Removal and Installation .....24	
<b>REAR SUSPENSION BEAM</b> .....14	Inspection .....25	
Exploded View .....14		
Removal and Installation .....14		

Disposal .....	26	Inspection .....	34
<b>COIL SPRING .....</b>	<b>27</b>	<b>REAR STABILIZER .....</b>	<b>35</b>
Exploded View .....	27	Exploded View .....	35
Removal and Installation .....	27	Removal and Installation .....	35
Inspection .....	28	Inspection .....	35
<b>SUSPENSION ARM .....</b>	<b>29</b>	<b>REAR SUSPENSION ASSEMBLY .....</b>	<b>36</b>
Exploded View .....	29	Exploded View .....	36
Removal and Installation .....	29	Removal and Installation .....	36
Inspection .....	30	Inspection .....	37
<b>LOWER LINK .....</b>	<b>31</b>	<b>SERVICE DATA AND SPECIFICATIONS</b>	
Exploded View .....	31	<b>(SDS) .....</b>	<b>38</b>
Removal and Installation .....	31	<b>SERVICE DATA AND SPECIFICATIONS</b>	
Inspection .....	32	<b>(SDS) .....</b>	<b>38</b>
<b>UPPER LINK .....</b>	<b>33</b>	Wheel Alignment .....	38
Exploded View .....	33	Wheelarch Height .....	38
Removal and Installation .....	33		

< PRECAUTION >

## PRECAUTION

### PRECAUTIONS

#### Precautions for Suspension

INFOID:000000009752369

- When installing rubber bushings, the final tightening must be carried out under unladen conditions with tires on ground. Spilled oil might shorten the life of rubber bushings. Be sure to wipe off any spilled oil.
- Unladen conditions mean that fuel, engine coolant and lubricant are full. Spare tire, jack, hand tools and mats are in designated positions.
- After servicing suspension parts, be sure to check wheel alignment.
- Self-lock nuts are not reusable. Always use new ones when installing. Since new self-lock nuts are pre-oiled, tighten as they are.
- The tightening surface must be kept free from oil/grease.
- When jacking up the vehicle with a floor jack, never hang the jack on the suspension beam.

#### Precautions for Removing of Battery Terminal

INFOID:000000010198981

- When removing the 12V battery terminal, turn OFF the ignition switch and wait at least 30 seconds.

**NOTE:**

ECU may be active for several tens of seconds after the ignition switch is turned OFF. If the battery terminal is removed before ECU stops, then a DTC detection error or ECU data corruption may occur.

- For vehicles with the 2-batteries, be sure to connect the main battery and the sub battery before turning ON the ignition switch.

**NOTE:**

If the ignition switch is turned ON with any one of the terminals of main battery and sub battery disconnected, then DTC may be detected.

- After installing the 12V battery, always check "Self Diagnosis Result" of all ECUs and erase DTC.

**NOTE:**

The removal of 12V battery may cause a DTC detection error.

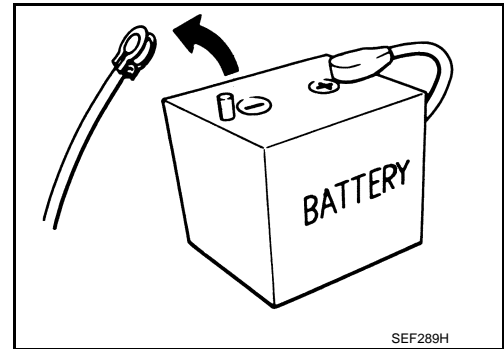

A  
B  
C  
D  
RSU  
F  
G  
H  
I  
J  
K  
L  
M  
N  
O  
P

# PREPARATION

< PREPARATION >

[2WD]

## PREPARATION

### PREPARATION

#### Commercial Service Tools

INFOID:000000009752370

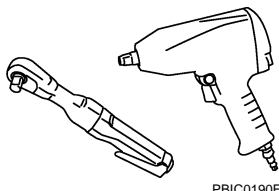
Tool name	Description
Power tool  PBIC0190E	Loosening bolts and nuts

# NOISE, VIBRATION AND HARSHNESS (NVH) TROUBLESHOOTING

< SYMPTOM DIAGNOSIS >

[2WD]

## SYMPTOM DIAGNOSIS

### NOISE, VIBRATION AND HARSHNESS (NVH) TROUBLESHOOTING

#### NVH Troubleshooting Chart

INFOID:000000009752371

Use chart below to find the cause of the symptom. If necessary, repair or replace these parts.

Symptom		Possible cause and SUSPECTED PARTS										Reference		
		Improper installation, looseness	Shock absorber deformation, damage or deflection	Bushing or mounting deterioration	Parts interference	Spring fatigue	Suspension looseness	Incorrect wheel alignment	REAR AXLE AND REAR SUSPENSION	TIRE	ROAD WHEEL		BRAKE	
Symptom	REAR SUSPENSION	Noise	x	x	x	x	x	x		x	x	x	x	RSU-8, RSU-12, RSU-14
		Shake	x	x	x	x		x		x	x	x	x	RSU-8
		Vibration	x	x	x	x	x			x	x			—
		Shimmy	x	x	x	x			x	x	x	x	x	—
		Judder	x	x	x					x	x	x	x	RSU-13
		Poor quality ride or handling	x	x	x	x	x		x	x	x	x		RSU-8, RSU-12, RSU-14 RSU-7 NVH in RAX and RSU sections NVH in WT section NVH in WT section NVH in BR section

x: Applicable

A  
B  
C  
D  
E  
F  
G  
H  
I  
J  
K  
L  
M  
N  
O  
P

RSU

## REAR SUSPENSION ASSEMBLY

< PERIODIC MAINTENANCE >

[2WD]

---

### PERIODIC MAINTENANCE

#### REAR SUSPENSION ASSEMBLY

##### Inspection

INFOID:000000009752372

##### COMPONENT PART

Check the mounting conditions (looseness, backlash) of each component and component conditions (wear, damage) are normal.

##### SHOCK ABSORBER ASSEMBLY

Check for oil leakage, damage, and replace if necessary.

# WHEEL ALIGNMENT

< PERIODIC MAINTENANCE >

[2WD]

## WHEEL ALIGNMENT

### Inspection

INFOID:000000009752373

### DESCRIPTION

#### CAUTION:

- The adjustment mechanisms of camber and toe-in are not included.
- If camber and toe-in is outside the standard, check front suspension parts for wear and damage. Replace suspect parts if a malfunction is detected.

Measure wheel alignment under unladen conditions.

#### NOTE:

“Unladen conditions” means that fuel, engine coolant, and lubricant are full. Spare tire, jack, hand tools and mats are in designated positions.

### PRELIMINARY CHECK

Check the following:

- Tires for improper air pressure and wear. Refer to [WT-54, "Tire Air Pressure"](#).
- Road wheels for runout.
- Wheel bearing axial end play. Refer to [RAX-6, "Inspection"](#).
- Shock absorber operation.
- Each mounting point of axle and suspension for looseness and deformation.
- Each of rear suspension beam and shock absorber for cracks, deformation, and other damage.
- Vehicle height (posture).

### GENERAL INFORMATION AND RECOMMENDATIONS

- A four-wheel thrust alignment should be performed.
- This type of alignment is recommended for any NISSAN/INFINITI vehicle.
- The four-wheel “thrust” process helps ensure that the vehicle is properly aligned and the steering wheel is centered.
- The alignment rack itself should be capable of accepting any NISSAN/INFINITI vehicle.
- The rack should be checked to ensure that it is level.
- Check the machine is properly calibrated.
- Your alignment equipment should be regularly calibrated in order to give correct information.
- Check with the manufacturer of your specific equipment for their recommended Service/Calibration Schedule.

### ALIGNMENT PROCESS

#### IMPORTANT:

Use only the alignment specifications listed in this Service Manual.

- When displaying the alignment settings, many alignment machines use “indicators”: (Green/red, plus or minus, Go/No Go). **Never use these indicators.**
- The alignment specifications programmed into your machine that operate these indicators may not be correct.
- This may result in an ERROR.
- Most camera-type alignment machines are equipped with both “Rolling Compensation” method and optional “Jacking Compensation” method to “compensate” the alignment targets or head units. “Rolling Compensation” is the preferred method.
- If using the “Rolling Compensation” method, after installing the alignment targets or head units, push or pull on the rear wheel to move the vehicle. **Do not push or pull on the vehicle body.**
- If using the “Jacking Compensation” method, after installing the alignment targets or head units, raise the vehicle and rotate the wheels 1/2 turn both ways.

#### NOTE:

- Do not use the “Rolling Compensation” method if you are using sensor-type alignment equipment.
- Follow all instructions for the alignment machine you're using for more information.

A

B

C

D

RSU

F

G

H

I

J

K

L

M

N

O

P

# REAR SHOCK ABSORBER

< REMOVAL AND INSTALLATION >

[2WD]

## REMOVAL AND INSTALLATION

### REAR SHOCK ABSORBER

Exploded View

INFOID:000000009752374

EXCEPT FOR 18 INCH TIRE

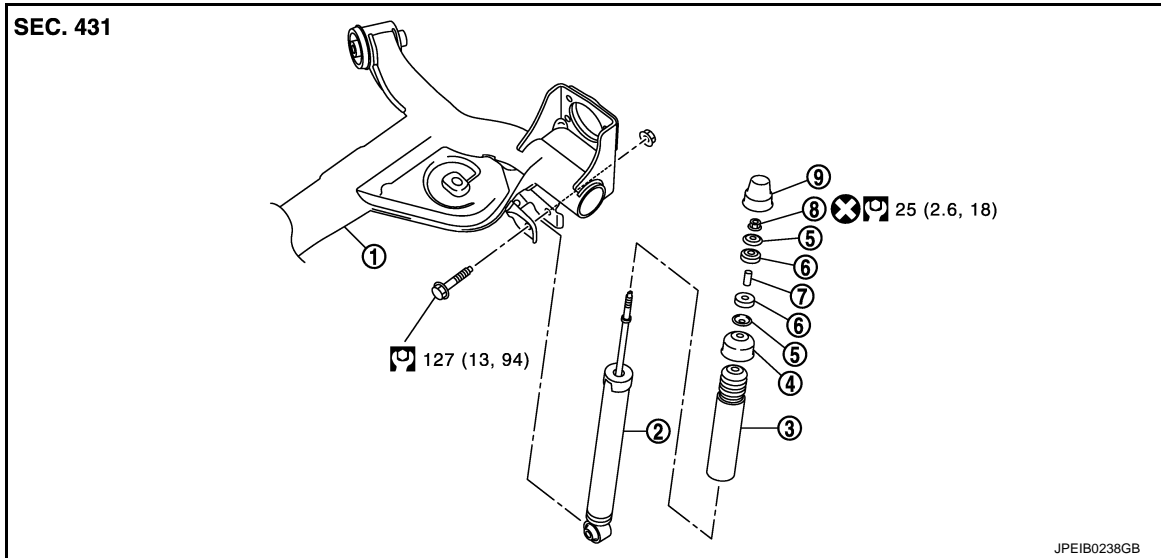

- |                         |                        |                 |
|-------------------------|------------------------|-----------------|
| 1. Rear suspension beam | 2. Shock absorber      | 3. Bound bumper |
| 4. Bound bumper cover   | 5. Washer              | 6. Bushing      |
| 7. Distance tube        | 8. Piston rod lock nut | 9. Cap          |

⊗: Always replace after every disassembly.

⊞: N·m (kg·m, ft·lb)

FOR 18 INCH TIRE

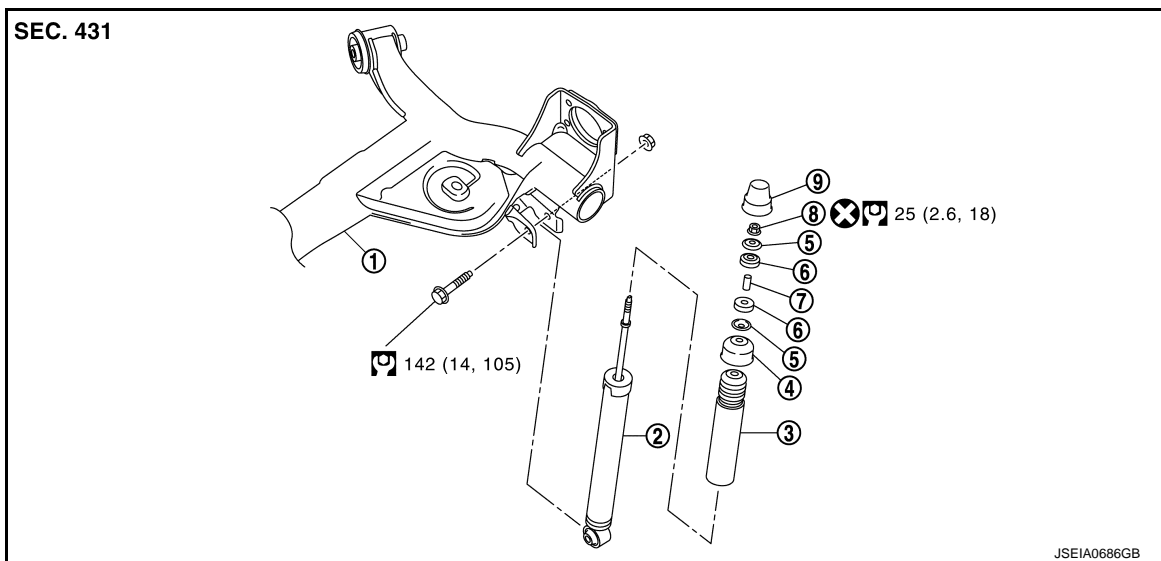

- |                         |                        |                 |
|-------------------------|------------------------|-----------------|
| 1. Rear suspension beam | 2. Shock absorber      | 3. Bound bumper |
| 4. Bound bumper cover   | 5. Washer              | 6. Bushing      |
| 7. Distance tube        | 8. Piston rod lock nut | 9. Cap          |



# REAR SHOCK ABSORBER

## < REMOVAL AND INSTALLATION >

[2WD]

: Always replace after every disassembly.

: N·m (kg·m, ft·lb)

## Removal and Installation

INFOID:000000009752375

### REMOVAL

1. Remove tires with power tool. Refer to [WT-46. "Removal and Installation"](#).
2. Set suitable jack under rear suspension beam.

#### CAUTION:

- Never damage the suspension beam with a jack.
- Check the stable condition when using a jack.

3. Remove shock absorber mounting bolt (lower side) (1).
4. Remove shock absorber mask. Refer to [INT-33. "Exploded View"](#).
5. Remove cap.

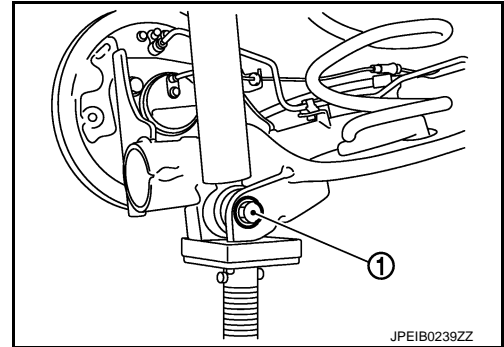

6. Remove piston rod lock nut (1), and then remove washer and bushing.

#### NOTE:

To loosen piston rod lock nut, fix the tip (A) of the piston rod.

7. Remove shock absorber assembly.
8. Remove bushing, distance tube, washer, bound bumper cover, and bound bumper from shock absorber.
9. Perform inspection after removal. Refer to [RSU-10. "Inspection"](#).

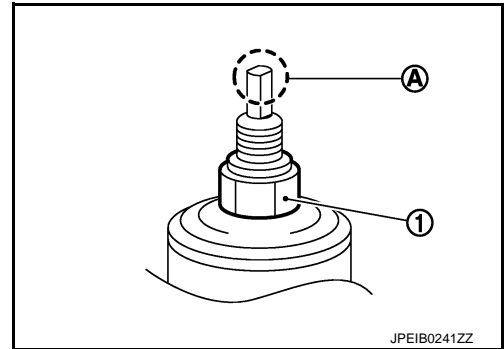

### INSTALLATION

Note the following, and install in the reverse order of removal.

- To install bushings (1), securely insert protrusion (A) into the hole on the vehicle body side.

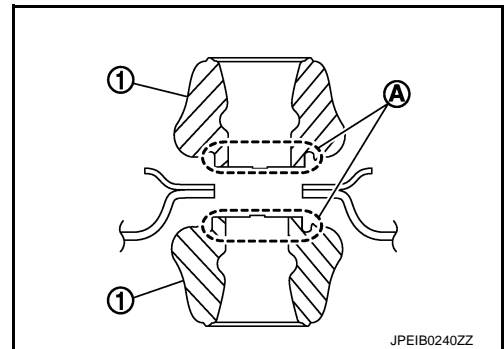

- Install washer (1) in the direction shown in the figure.

 : Bushing side

- Perform final tightening of bolts and nuts at the shock absorber lower side (rubber bushing), under unladen conditions with tires on level ground.

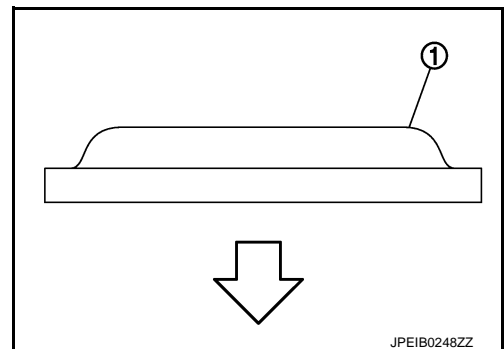

A

B

C

D

RSU

F

G

H

I

J

K

L

M

N

O

P

# REAR SHOCK ABSORBER

## < REMOVAL AND INSTALLATION >

[2WD]

- Hold a head (A) of shock absorber piston rod nut to have it rotate, then tighten the piston rod lock nut (1) to the specified torque.

**CAUTION:**

**Never reuse piston rod lock nut.**

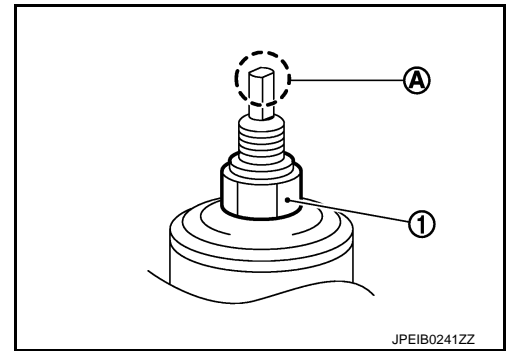

- When installing the cap, securely engage the cap groove (A) with the flange on the vehicle side.
- Perform inspection after installation. Refer to [RSU-10, "Inspection"](#).
- After replacing the shock absorber, always follow the disposal procedure to discard the shock absorber. Refer to [RSU-10, "Inspection"](#).

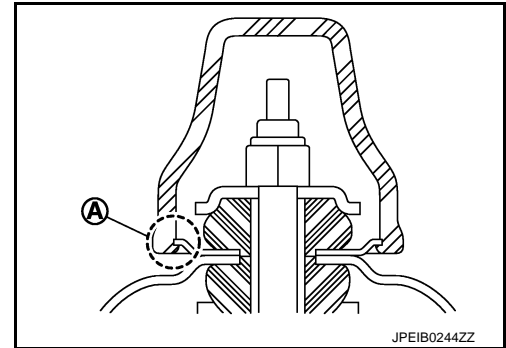

## Inspection

INFOID:000000009752376

### INSPECTION AFTER REMOVAL

#### Shock Absorber

Check the following items, and replace the part if necessary.

- Shock absorber for deformation, cracks, and other damage.
- Piston rod for damage, uneven wear, and distortion.
- Oil leakage.

#### Bound Bumper, Bushing

Check for cracks and damage. Replace it if necessary.

#### Washer, Bound Bumper Cover, Distance Tube

- Check for cracks and damage. Replace it if necessary.

### INSPECTION AFTER INSTALLATION

1. Check wheel alignment. Refer to [RSU-7, "Inspection"](#).
2. Adjust neutral position of steering angle sensor. Refer to [BRC-62, "Work Procedure"](#).

## Disposal

INFOID:000000009752377

1. Set shock absorber horizontally to the ground with the piston rod fully extracted.
2. Drill 2 – 3 mm (0.08 – 0.12 in) hole at the position (●) from top as shown in the figure to release gas gradually.

**CAUTION:**

- **Wear eye protection (safety glasses).**
- **Wear gloves.**
- **Be careful with metal chips or oil blown out by the compressed gas.**

**NOTE:**

- Drill vertically in this direction.
- Directly to the outer tube avoiding brackets.
- The gas is clear, colorless, odorless, and harmless.

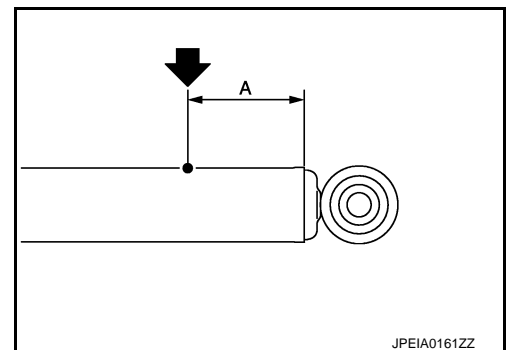

**A : 20 – 30 mm (0.79 – 1.18 in)**

## REAR SHOCK ABSORBER

< REMOVAL AND INSTALLATION >

[2WD]

3. Position the drilled hole downward and drain oil by moving the piston rod several times.

**CAUTION:**

**Dispose of drained oil according to the law and local regulations.**

A

B

C

D

RSU

F

G

H

I

J

K

L

M

N

O

P

# COIL SPRING

< REMOVAL AND INSTALLATION >

[2WD]

## COIL SPRING

Exploded View

INFOID:000000009752378

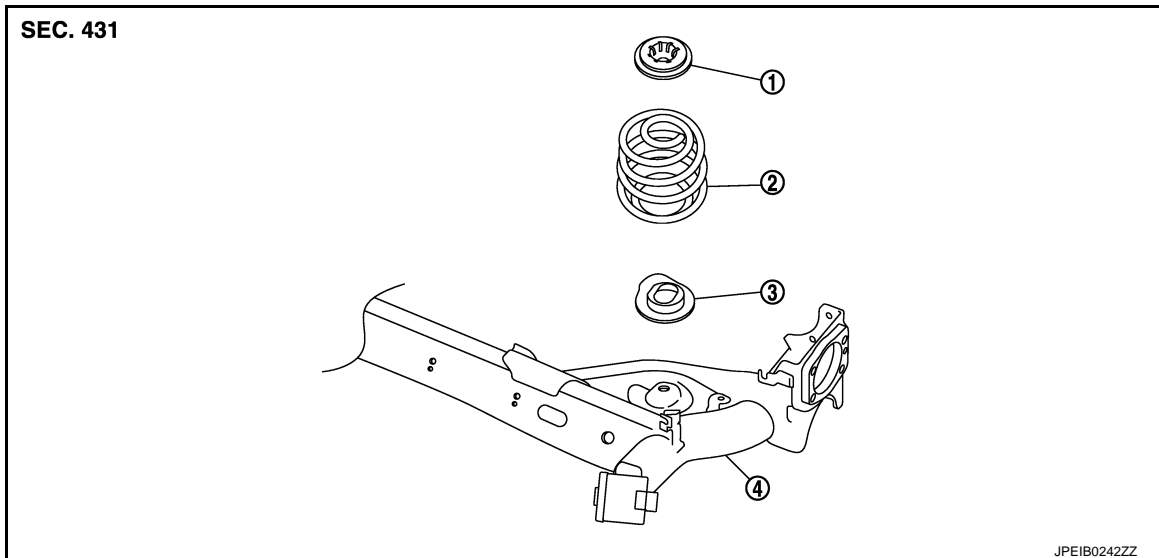

1. Upper rubber seat
2. Coil spring
3. Lower rubber seat
4. Rear suspension beam

## Removal and Installation

INFOID:000000009752379

### REMOVAL

1. Remove tires with power tool. Refer to [WT-46, "Removal and Installation"](#).
2. Set jack under rear suspension beam.  
**CAUTION:**
  - Never damage the suspension beam with a jack.
  - Check the stable condition when using a jack.
3. Remove rear shock absorber mounting bolts (lower side). Refer to [RSU-8, "Exploded View"](#).
4. Slowly lower jack, then remove upper rubber seat, coil spring and lower rubber seat from rear suspension beam.  
**CAUTION:**  
**Operate while checking that jack supporting status is stable.**
5. Perform inspection after removal. Refer to [RSU-13, "Inspection"](#).

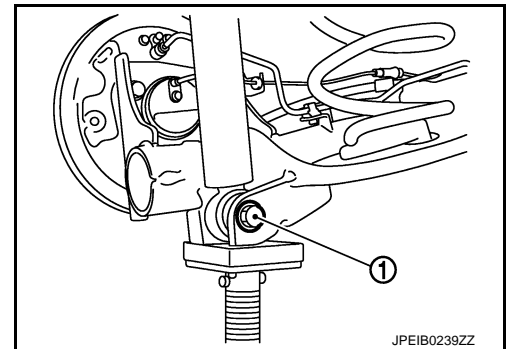

### INSTALLATION

Note the following, and install in the reverse order of removal.

- Install lower rubber seat with its protrusion (A) on the lower area aligned with the hole of rear suspension beam.

B : Coil spring lower end

- Securely install coil spring with the lower end of the major diameter aligned with the steps of lower rubber seat.
- Perform inspection after installation. Refer to [RSU-13, "Inspection"](#).

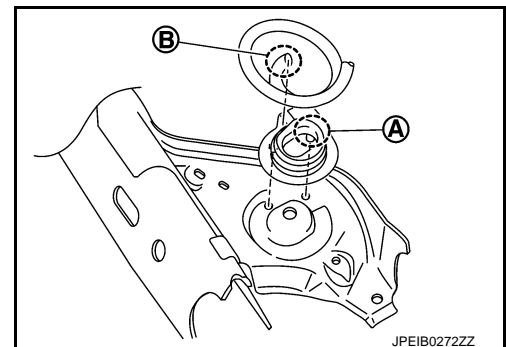

# COIL SPRING

< REMOVAL AND INSTALLATION >

[2WD]

## Inspection

INFOID:000000009752380

### INSPECTION AFTER REMOVAL

Check rubber seat and coil spring for deformation, crack, and damage. Replace it if necessary.

### INSPECTION AFTER INSTALLATION

1. Check wheel alignment. Refer to [RSU-7, "Inspection"](#).
2. Adjust neutral position of steering angle sensor. Refer to [BRC-62, "Work Procedure"](#).

A

B

C

D

RSU

F

G

H

I

J

K

L

M

N

O

P

# REAR SUSPENSION BEAM

< REMOVAL AND INSTALLATION >

[2WD]

## REAR SUSPENSION BEAM

Exploded View

INFOID:000000009752381

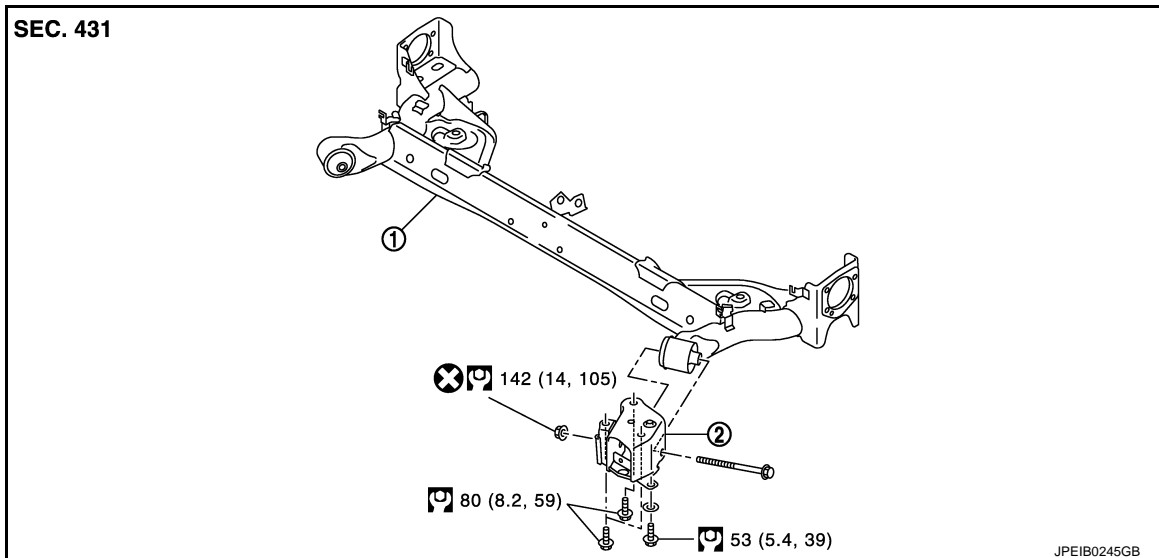

1. Rear suspension beam
2. Rear suspension arm bracket

⊗: Always replace after every disassembly.

□: N·m (kg-m, ft-lb)

## Removal and Installation

INFOID:000000009752382

### REMOVAL

1. Remove tires with power tool. Refer to [WT-46, "Removal and Installation"](#).
2. Drain brake fluid. Refer to [BR-10, "Draining"](#).
3. Remove wheel sensor and sensor harness. Refer to [BRC-135, "REAR WHEEL SENSOR : Removal and Installation"](#).
4. Remove brake caliper assembly. Refer to [BR-53, "BRAKE CALIPER ASSEMBLY : Removal and Installation"](#).
5. Remove disc rotor. Refer to [RAX-7, "Removal and Installation"](#).
6. Remove parking brake shoe assembly. Refer to [PB-8, "Removal and Installation"](#).
7. Remove parking brake cable from back plate and rear suspension beam. Refer to [PB-6, "Removal and Installation"](#).
8. Separate brake hose and brake tube. Refer to [BR-27, "REAR : Removal and Installation"](#).
9. Set suitable jack under rear suspension beam.  
**CAUTION:**
  - Never damage the suspension beam with a jack.
  - Check the stable condition when using a jack.
10. Remove shock absorber mounting bolts (lower side). Refer to [RSU-9, "Removal and Installation"](#).
11. Remove coil spring. Refer to [RSU-12, "Removal and Installation"](#).
12. Remove rear suspension arm bracket mounting bolts.
13. Remove rear suspension arm beam mounting bolts and nuts.
14. Slowly lower jack, remove rear suspension arm bracket and rear suspension beam from vehicle.  
**CAUTION:**
  - Operate while checking that jack supporting status is stable.
15. Remove wheel hub assembly. Refer to [RAX-7, "Removal and Installation"](#).
16. Remove rear suspension arm bracket from rear suspension beam.

# REAR SUSPENSION BEAM

[2WD]

## < REMOVAL AND INSTALLATION >

17. Perform inspection after removal. Refer to [RSU-15, "Inspection"](#).

### INSTALLATION

Note the following, and install in the reverse order of removal.

- Never reuse rear suspension beam mounting nut.
- To install rear suspension arm bracket to the vehicle, temporarily tighten the bolts before tightening to the specified torque, referring to the tightening method and the numerical order shown below:

Temporary tightening : 1 → 2 → 3 → 4

Final tightening (specified torque) : 5 → 6 → 3 → 4 → 1 → 2 → 7 → 8

← : Vehicle front

- Perform final tightening of rear suspension beam installation position (rubber bushing), under unladen conditions with tires on level ground.
- Perform inspection after installation. Refer to [RSU-15, "Inspection"](#).

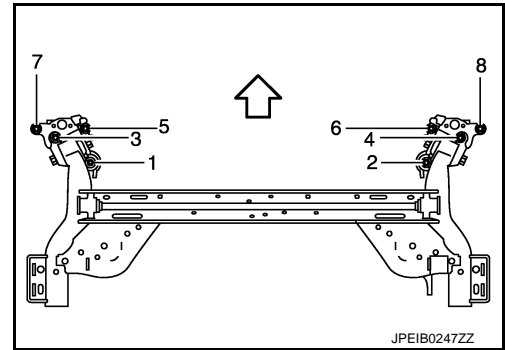

### Inspection

INFOID:000000009752383

### INSPECTION AFTER REMOVAL

Check rear suspension beam and rear suspension beam bracket for deformation, cracks or damage. Replace the part if necessary.

### INSPECTION AFTER INSTALLATION

1. Check wheel sensor harness for proper connection. Refer to [BRC-133, "REAR WHEEL SENSOR : Exploded View"](#).
2. Adjust parking brake. Refer to [PB-3, "Inspection and Adjustment"](#).
3. Check wheel alignment. Refer to [RSU-7, "Inspection"](#).
4. Adjust neutral position of steering angle sensor. Refer to [BRC-62, "Work Procedure"](#).

# SERVICE DATA AND SPECIFICATIONS (SDS)

< SERVICE DATA AND SPECIFICATIONS (SDS)

[2WD]

## SERVICE DATA AND SPECIFICATIONS (SDS)

### SERVICE DATA AND SPECIFICATIONS (SDS)

#### Wheel Alignment

INFOID:000000009752384

#### FOR USA MODELS

Item		Standard	
Camber Degree minute (Decimal degree)	Minimum	-2° 01' (-2.01°)	
	Nominal	-1° 31' (-1.52°)	
	Maximum	-1° 01' (-1.02°)	
Toe-in	Total toe-in Distance	Minimum	Out 1.1 mm (Out 0.043 in)
		Nominal	In 2.9 mm (In 0.114 in)
		Maximum	In 6.9 mm (In 0.272 in)
	Toe angle (left wheel and right wheel) <sup>*1</sup> Degree minute (Decimal degree)	Minimum	Out 0° 05' 00" (Out 0.08°)
		Nominal	In 0° 15' 00" (In 0.25°)
		Maximum	In 0° 35' 00" (In 0.58°)

Measure value under unladen<sup>\*2</sup> conditions.

\*1: Since adjustment mechanism is not included, the value of the left and right wheels (both wheels) must be used as the standard value.

\*2: Fuel, engine coolant and lubricant are full. Spare tire, jack, hand tools and mats are in designated positions.

#### FOR CANADA MODELS

Item		Standard	
Camber Degree minute (Decimal degree)	Minimum	-2° 01' (-2.01°)	
	Nominal	-1° 31' (-1.52°)	
	Maximum	-1° 01' (-1.02°)	
Toe-in	Total toe-in Distance	Minimum	Out 1.2 mm (Out 0.047 in)
		Nominal	In 2.8 mm (In 0.11 in)
		Maximum	In 6.8 mm (In 0.268 in)
	Toe angle (left wheel and right wheel) <sup>*1</sup> Degree minute (Decimal degree)	Minimum	Out 0° 06' 00" (Out 0.10°)
		Nominal	In 0° 14' 00" (In 0.23°)
		Maximum	In 0° 35' 00" (In 0.58°)

Measure value under unladen<sup>\*2</sup> conditions.

\*1: Since adjustment mechanism is not included, the value of the left and right wheels (both wheels) must be used as the standard value.

\*2: Fuel, engine coolant and lubricant are full. Spare tire, jack, hand tools and mats are in designated positions.

#### Wheelarch Height

INFOID:000000009752385

#### FOR USA MODELS

Item	Standard	NISMO RS	Standard
Transmission	M/T		CVT
Tire Size	17 inch	18 inch	17 inch
Front (Hf)	734 mm (28.90 in)	725 mm (28.54 in)	735 mm (28.94 in)



# SERVICE DATA AND SPECIFICATIONS (SDS)

< SERVICE DATA AND SPECIFICATIONS (SDS)

[2WD]

Item	Standard	NISMO RS	Standard
Transmission	M/T		CVT
Tire Size	17 inch	18 inch	17 inch
Rear (Hr)	745 mm (29.33 in)	739 mm (29.09 in)	746 mm (29.37 in)

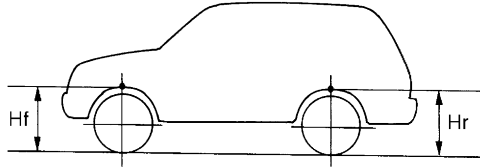

SFA746B

Measure value under unladen\* conditions.

\*: Fuel, engine coolant and lubricant are full. Spare tire, jack, hand tools and mats are in designated positions.

## FOR CANADA MODELS

Item	Standard	NISMO RS	Standard
Transmission	M/T		CVT
Tire Size	17 inch	18 inch	17 inch
Front (Hf)	735 mm (28.94 in)	725 mm (28.54 in)	735 mm (28.94 in)
Rear (Hr)	745 mm (29.33 in)	740 mm (29.13 in)	746 mm (29.37 in)

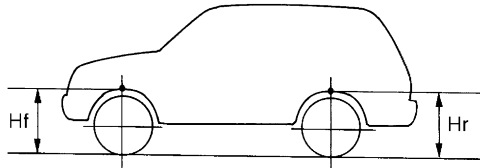

SFA746B

Measure value under unladen\* conditions.

\*: Fuel, engine coolant and lubricant are full. Spare tire, jack, hand tools and mats are in designated positions.

A  
B  
C  
D  
F  
G  
H  
I  
J  
K  
L  
M  
N  
O  
P

RSU

< PRECAUTION >

## PRECAUTION

### PRECAUTIONS

#### Precautions for Suspension

INFOID:000000009752386

- When installing rubber bushings, the final tightening must be carried out under unladen conditions with tires on ground. Spilled oil might shorten the life of rubber bushings. Be sure to wipe off any spilled oil.
- Unladen conditions mean that fuel, engine coolant and lubricant are full. Spare tire, jack, hand tools and mats are in designated positions.
- After servicing suspension parts, be sure to check wheel alignment.
- Self-lock nuts are not reusable. Always use new ones when installing. Since new self-lock nuts are pre-oiled, tighten as they are.
- The tightening surface must be kept free from oil/grease.

#### Precautions for Removing of Battery Terminal

INFOID:000000010198984

- When removing the 12V battery terminal, turn OFF the ignition switch and wait at least 30 seconds.

**NOTE:**

ECU may be active for several tens of seconds after the ignition switch is turned OFF. If the battery terminal is removed before ECU stops, then a DTC detection error or ECU data corruption may occur.

- For vehicles with the 2-batteries, be sure to connect the main battery and the sub battery before turning ON the ignition switch.

**NOTE:**

If the ignition switch is turned ON with any one of the terminals of main battery and sub battery disconnected, then DTC may be detected.

- After installing the 12V battery, always check "Self Diagnosis Result" of all ECUs and erase DTC.

**NOTE:**

The removal of 12V battery may cause a DTC detection error.

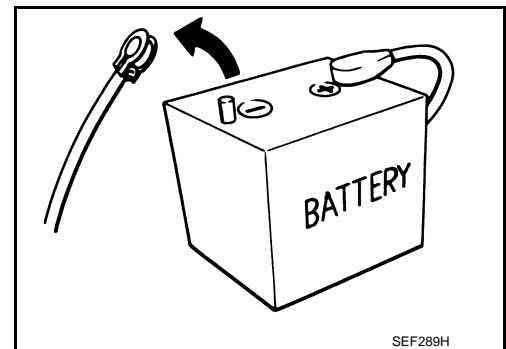

# PREPARATION

< PREPARATION >

[AWD]

## PREPARATION

### PREPARATION

#### Commercial Service Tools

INFOID:000000009752387

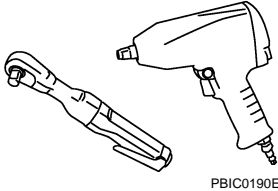
Tool name	Description
Power tool  PBIC0190E	Loosening bolts and nuts

A

B

C

D

RSU

F

G

H

I

J

K

L

M

N

O

P

# NOISE, VIBRATION AND HARSHNESS (NVH) TROUBLESHOOTING

< SYMPTOM DIAGNOSIS >

[AWD]

## SYMPTOM DIAGNOSIS

### NOISE, VIBRATION AND HARSHNESS (NVH) TROUBLESHOOTING

#### NVH Troubleshooting Chart

INFOID:000000009752388

Use chart below to find the cause of the symptom. If necessary, repair or replace these parts.

Symptom		Possible cause and SUSPECTED PARTS														Reference			
		Improper installation, looseness	Shock absorber deformation, damage or deflection	Bushing or mounting deterioration	Parts interference	Spring fatigue	Suspension looseness	Incorrect wheel alignment	Stabilizer bar fatigue	PROPELLER SHAFT	DIFFERENTIAL	REAR AXLE AND REAR SUSPENSION	TIRE	ROAD WHEEL	DRIVE SHAFT		BRAKE	STEERING	
Symptom	REAR SUSPENSION	Noise	x	x	x	x	x	x			x	x	x	x	x	x	x		<a href="#">RSU-24, RSU-27, RSU-29, RSU-31, RSU-33, RSU-35, RSU-36</a> <a href="#">RSU-25</a> — — <a href="#">RSU-28</a> <a href="#">RSU-24, RSU-27, RSU-29, RSU-31, RSU-33, RSU-35, RSU-36</a> <a href="#">RSU-22</a> <a href="#">RSU-35</a> NVH in DLN section. NVH in DLN section. NVH in RAX and RSU sections. NVH in WT section. NVH in WT section. NVH in RAX section. NVH in BR section. NVH in ST section.
		Shake	x	x	x	x		x			x		x	x	x	x	x	x	
		Vibration	x	x	x	x	x				x		x	x		x		x	
		Shimmy	x	x	x	x			x				x	x	x		x	x	
		Judder	x	x	x								x	x	x		x	x	
		Poor quality ride or handling	x	x	x	x	x		x	x			x	x	x				

x: Applicable

# REAR SUSPENSION ASSEMBLY

< PERIODIC MAINTENANCE >

[AWD]

## PERIODIC MAINTENANCE

### REAR SUSPENSION ASSEMBLY

#### Inspection

INFOID:000000009752389

#### MOUNTING INSPECTION

Check the mounting conditions (looseness, backlash) of each component and component conditions (wear, damage) are normal.

#### SHOCK ABSORBER

Check for oil leakage and damage. Replace it if necessary.

A

B

C

D

RSU

F

G

H

I

J

K

L

M

N

O

P

## WHEEL ALIGNMENT

### Inspection

INFOID:000000009752390

#### DESCRIPTION

Measure wheel alignment under unladen conditions.

#### NOTE:

"Unladen conditions" means that fuel, engine coolant, and lubricant are full. Spare tire, jack, hand tools and mats are in designated positions.

#### PRELIMINARY CHECK

Check the following:

- Tires for improper air pressure and wear. Refer to [WT-54, "Tire Air Pressure"](#).
- Road wheels for runout.
- Wheel bearing axial end play. Refer to [RAX-14, "Inspection"](#).
- Shock absorber operation.
- Each mounting point of axle and suspension for looseness and deformation.
- Each of lower link, upper link, rear suspension member, suspension arm, and shock absorber for cracks, deformation, and other damage.
- Vehicle height (posture).

#### GENERAL INFORMATION AND RECOMMENDATIONS

- A four-wheel thrust alignment should be performed.
- This type of alignment is recommended for any NISSAN/INFINITI vehicle.
- The four-wheel "thrust" process helps ensure that the vehicle is properly aligned and the steering wheel is centered.
- The alignment rack itself should be capable of accepting any NISSAN/INFINITI vehicle.
- The rack should be checked to ensure that it is level.
- Make sure the machine is properly calibrated.
- Your alignment equipment should be regularly calibrated in order to give correct information.
- Check with the manufacturer of your specific equipment for their recommended Service/Calibration Schedule.

#### ALIGNMENT PROCESS

#### IMPORTANT:

Use only the alignment specifications listed in this Service Manual.

- When displaying the alignment settings, many alignment machines use "indicators": (Green/red, plus or minus, Go/No Go). **Never use these indicators.**
- The alignment specifications programmed into your machine that operate these indicators may not be correct.
- This may result in an ERROR.
- Most camera-type alignment machines are equipped with both "Rolling Compensation" method and optional "Jacking Compensation" method to "compensate" the alignment targets or head units. "Rolling Compensation" is the preferred method.
- If using the "Rolling Compensation" method, after installing the alignment targets or head units, push or pull on the rear wheel to move the vehicle. **Do not push or pull on the vehicle body.**
- If using the "Jacking Compensation" method, after installing the alignment targets or head units, raise the vehicle and rotate the wheels 1/2 turn both ways.

#### NOTE:

- Do not use the "Rolling Compensation" method if you are using sensor-type alignment equipment.
- Follow all instructions for the alignment machine you're using for more information.

### Adjustment

INFOID:000000009752391

#### CAMBER, TOE-IN

#### CAUTION:

- **Adjust camber first, then adjust toe-in last. never change the order.**
- **If camber angle needs to be adjusted, toe-in adjustment is necessary.**
- **Minimize difference of left and right toe-in within tolerance.**

1. Loosen mounting nuts of upper link and lower link on the suspension member side.

# WHEEL ALIGNMENT

[AWD]

< PERIODIC MAINTENANCE >

- Adjust camber and toe-in by turning upper link adjusting bolt (1) and lower link adjusting bolt (2) alternately.

- A : Left side
- B : Right side

**NOTE:**

Upper link adjusting bolt

Positive direction : Upper link slides into inner side of vehicle.

Negative direction : Upper link slides into outer side of vehicle.

Lower link adjusting bolt

Positive direction : Lower link slides into outer side of vehicle.

Negative direction : Lower link slides into inner side of vehicle.

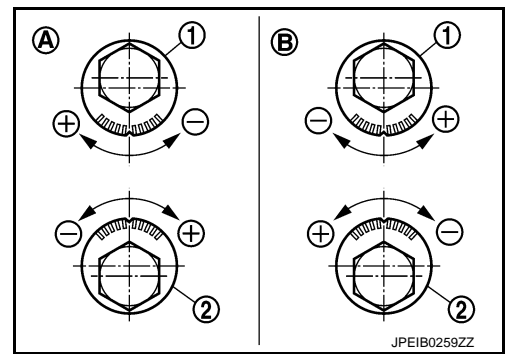

- Refer to the table below for easier adjustment.

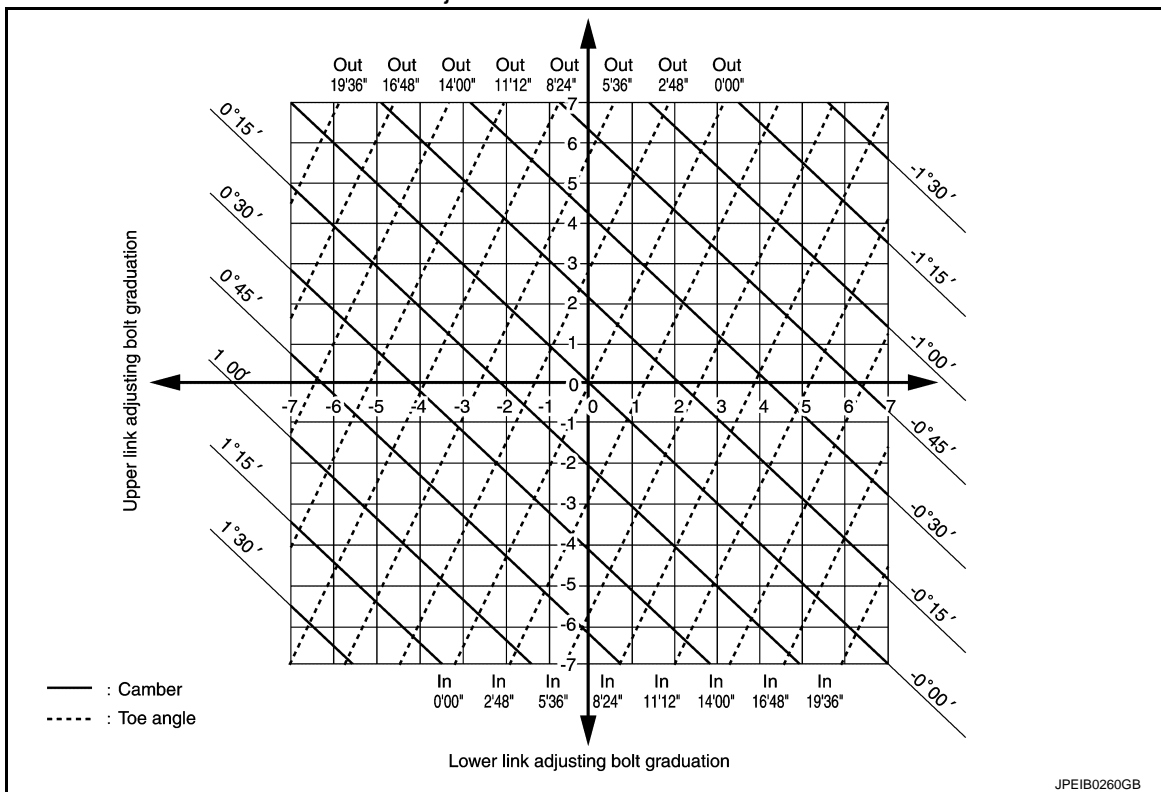

- Obtain the amount of camber and toe-in by calculating the difference between the measurement result and the standard value.
- Obtain the needed adjustment amount from the graph and move adjusting bolts, respectively.

- After adjustment, tighten mounting nuts of upper link and lower link on the suspension member side.

**CAUTION:**

**When tightening nut to the specified torque, the bolt must be fixed with a wrench.**

- Adjust neutral position of steering angle sensor. Refer to [BRC-62. "Work Procedure"](#).

# REAR SHOCK ABSORBER

< REMOVAL AND INSTALLATION >

[AWD]

## REMOVAL AND INSTALLATION

### REAR SHOCK ABSORBER

Exploded View

INFOID:000000009752392

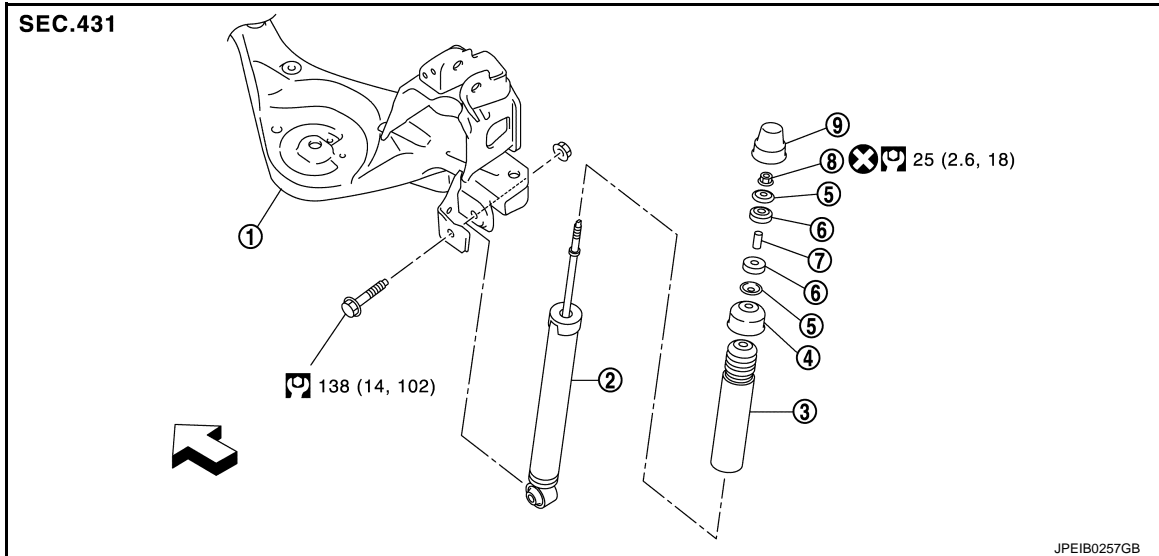

- |                       |                        |                 |
|-----------------------|------------------------|-----------------|
| 1. Suspension arm     | 2. Shock absorber      | 3. Bound bumper |
| 4. Bound bumper cover | 5. Washer              | 6. Bushing      |
| 7. Distance tube      | 8. Piston rod lock nut | 9. Cap          |

↔: Vehicle front

⊗: Always replace after every disassembly.

Ⓜ: N·m (kg·m, ft·lb)

## Removal and Installation

INFOID:000000009752393

### REMOVAL

1. Remove tires with power tool. Refer to [WT-46, "Removal and Installation"](#).
2. Set suitable jack under suspension arm.

#### CAUTION:

- Never damage the suspension arm with a jack.
- Check the stable condition when using a jack.

3. Remove shock absorber mounting bolt and nut (lower side).
4. Remove shock absorber mask. Refer to [INT-33, "Exploded View"](#).
5. Remove cap.
6. Remove piston rod lock nut (1), and then remove washer and bushing.

#### NOTE:

To loosen piston rod lock nut, fix the tip (A) of the piston rod.

7. Remove shock absorber assembly.
8. Remove bushing, distance tube, bound bumper cover, and bound bumper from shock absorber.
9. Perform inspection after removal. Refer to [RSU-25, "Inspection"](#).

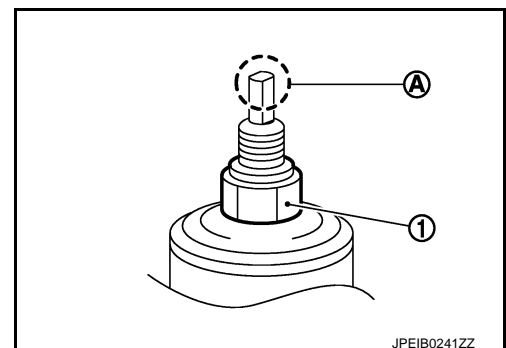

### INSTALLATION



# REAR SHOCK ABSORBER

[AWD]

## < REMOVAL AND INSTALLATION >

Note the following, and install in the reverse order of removal.

- To install bushings (1), securely insert protrusion (A) into the hole on the vehicle body side.

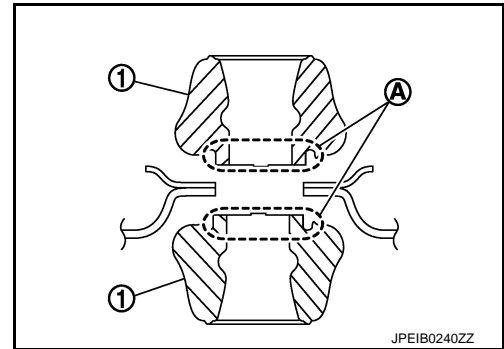

- Install washer (1) in the direction shown in the figure.

← : Bushing side

- Perform final tightening of bolts and nuts at the shock absorber lower side (rubber bushing), under unladen conditions with tires on level ground.

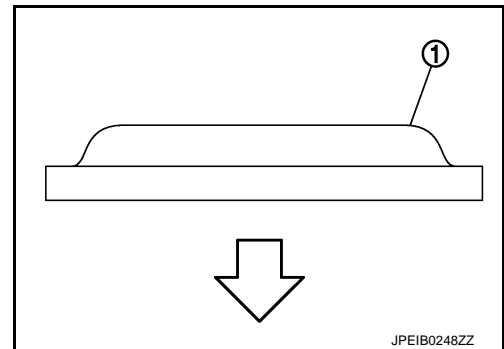

- Hold a head (A) of shock absorber piston rod nut to have it rotate, then tighten the piston rod lock nut (1) to the specified torque.

**CAUTION:**

**Never reuse piston rod lock nut.**

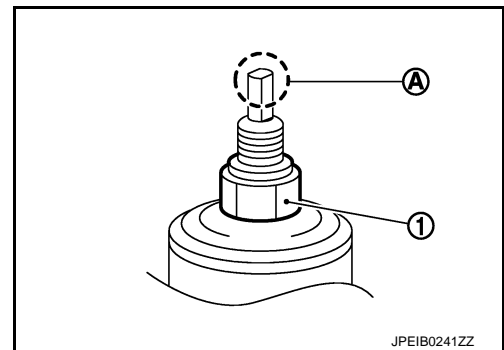

- When installing the cap, securely engage the cap groove (A) with the flange on the vehicle side.
- Perform inspection after installation. Refer to [RSU-25, "Inspection"](#).
- After replacing the shock absorber, always follow the disposal procedure to discard the shock absorber. Refer to [RSU-25, "Inspection"](#).

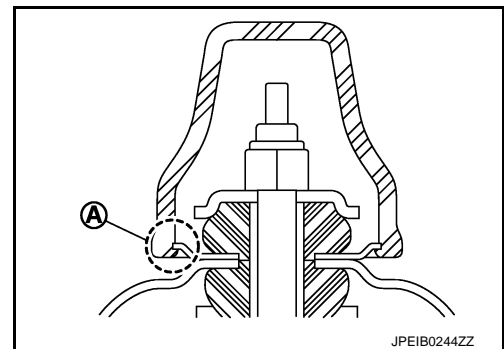

INFOID:000000009752394

## Inspection

### INSPECTION AFTER REMOVAL

#### Shock Absorber

Check the following items, and replace the part if necessary.

- Shock absorber for deformation, cracks, and other damage.
- Piston rod for damage, uneven wear, and distortion.
- Oil leakage.

# REAR SHOCK ABSORBER

[AWD]

## < REMOVAL AND INSTALLATION >

Bound Bumper, Bushing

Check for cracks and damage. Replace it if necessary.

Washer, Bound Bumper Cover, Distance Tube

- Check for cracks and damage. Replace it if necessary.

## INSPECTION AFTER INSTALLATION

1. Check wheel alignment. Refer to [RSU-22. "Inspection"](#).
2. Adjust neutral position of steering angle sensor. Refer to [BRC-62. "Work Procedure"](#).

## Disposal

INFOID:000000009752395

1. Set shock absorber horizontally to the ground with the piston rod fully extracted.
2. Drill 2 – 3 mm (0.08 – 0.12 in) hole at the position (●) from top as shown in the figure to release gas gradually.

### CAUTION:

- **Wear eye protection (safety glasses).**
- **Wear gloves.**
- **Be careful with metal chips or oil blown out by the compressed gas.**

### NOTE:

- Drill vertically in this direction.
- Directly to the outer tube avoiding brackets.
- The gas is clear, colorless, odorless, and harmless.

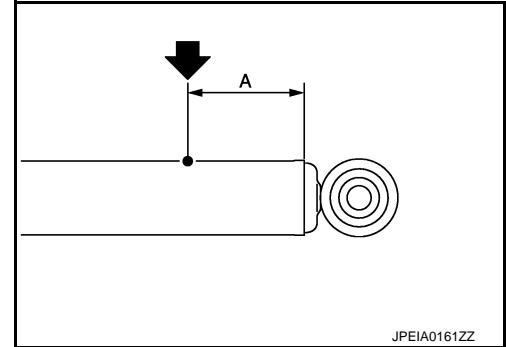

**A : 20 – 30 mm (0.79 – 1.18 in)**

3. Position the drilled hole downward and drain oil by moving the piston rod several times.

### CAUTION:

**Dispose of drained oil according to the law and local regulations.**

# COIL SPRING

< REMOVAL AND INSTALLATION >

[AWD]

## COIL SPRING

Exploded View

INFOID:000000009752396

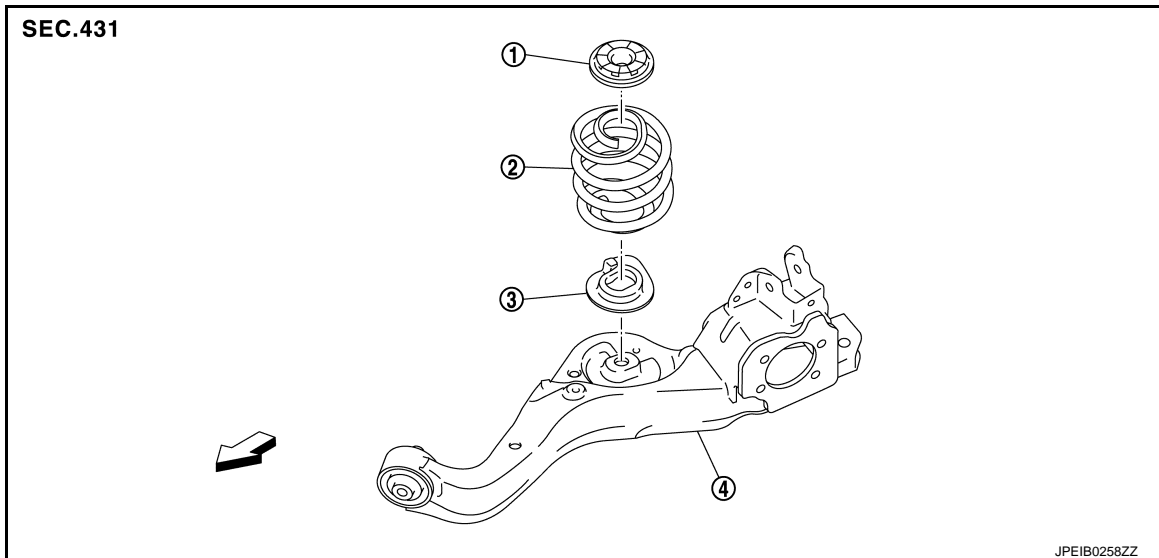

1. Upper rubber seat
2. Coil spring
3. Lower rubber seat
4. Suspension arm

←: Vehicle front

## Removal and Installation

INFOID:000000009752397

### REMOVAL

1. Remove tires with power tool. Refer to [WT-46, "Removal and Installation"](#).
2. Remove wheel sensor and sensor harness. Refer to [BRC-135, "REAR WHEEL SENSOR : Removal and Installation"](#).
3. Set jack under suspension arm.  
**CAUTION:**
  - Never damage the suspension arm with a jack.
  - Check the stable condition when using a jack.
4. Separate rear shock absorber lower side form suspension arm. Refer to [RSU-24, "Removal and Installation"](#).
5. Separate upper link from suspension arm.
6. Slowly lower jack, then remove upper rubber seat, coil spring and lower rubber seat from suspension arm.  
**CAUTION:**  
**Operate while checking that jack supporting status is stable.**
7. Perform inspection after removal. Refer to [RSU-28, "Inspection"](#).

### INSTALLATION

Note the following, and install in the reverse order of removal.

## COIL SPRING

### < REMOVAL AND INSTALLATION >

[AWD]

- Install the lower rubber seat a projection (A) is attached as suspension arm mounting hole (B).
- Match up lower rubber seat indentions and suspension arm grooves and attach.
- Perform inspection after installation. Refer to [RSU-28, "Inspection"](#).

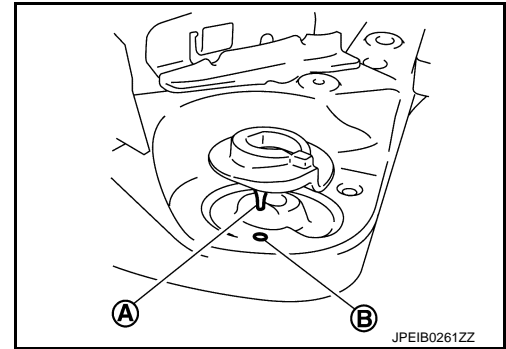

### Inspection

INFOID:000000009752398

#### INSPECTION AFTER REMOVAL

Check rubber seat and coil spring for deformation, crack, and damage. Replace it if necessary.

#### INSPECTION AFTER INSTALLATION

1. Check wheel sensor harness for proper connection. Refer to [BRC-133, "REAR WHEEL SENSOR : Exploded View"](#).
2. Check wheel alignment. Refer to [RSU-22, "Inspection"](#).
3. Adjust neutral position of steering angle sensor. Refer to [BRC-62, "Work Procedure"](#).

# SUSPENSION ARM

< REMOVAL AND INSTALLATION >

[AWD]

## SUSPENSION ARM

Exploded View

INFOID:000000009752399

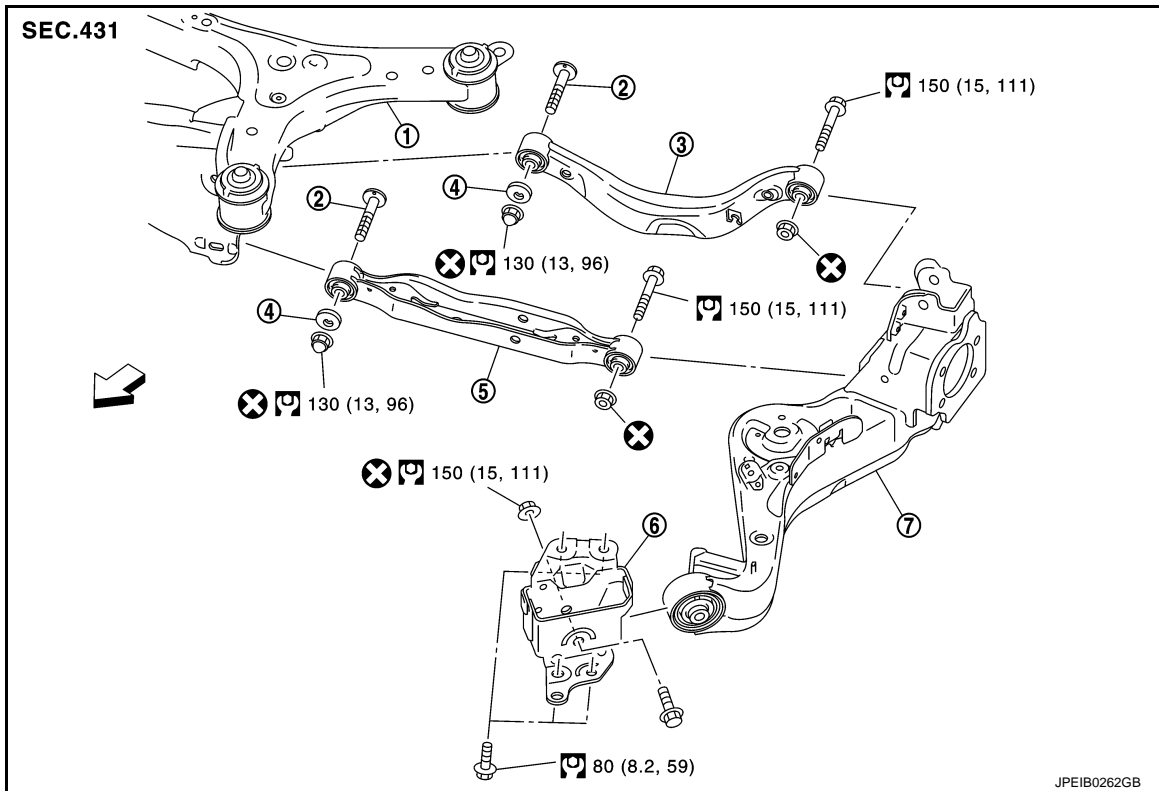

- |                           |                   |                           |
|---------------------------|-------------------|---------------------------|
| 1. Rear suspension member | 2. Adjusting bolt | 3. Upper link             |
| 4. Eccentric disk         | 5. Lower link     | 6. Suspension arm bracket |
| 7. Suspension arm         |                   |                           |

← Vehicle front

⊗: Always replace after every disassembly.

⊞: N·m (kg·m, ft·lb)

## Removal and Installation

INFOID:000000009752400

### REMOVAL

1. Remove tires with power tool. Refer to [WT-46, "Removal and Installation"](#).
2. Drain brake fluid. Refer to [BR-10, "Draining"](#).
3. Remove wheel sensor and sensor harness. Refer to [BRC-135, "REAR WHEEL SENSOR : Removal and Installation"](#).
4. Remove caliper assembly. Hang caliper assembly in a place where it will not interfere with work. Refer to [BR-53, "BRAKE CALIPER ASSEMBLY : Removal and Installation"](#).  
**CAUTION:**  
**Never depress brake pedal while brake caliper is removed.**
5. Remove disc rotor. Refer to [RAX-16, "Removal and Installation"](#).
6. Remove parking brake cable mounting bolt. Refer to [PB-6, "Removal and Installation"](#).
7. Separate the brake tube from the brake hose, and remove lock plate. Refer to [BR-24, "REAR : Exploded View"](#).
8. Remove wheel hub and bearing assembly. Refer to [RAX-16, "Removal and Installation"](#).
9. Remove parking brake shoe and back plate. Refer to [PB-8, "Removal and Installation"](#).

# SUSPENSION ARM

[AWD]

## < REMOVAL AND INSTALLATION >

10. Set jack under suspension arm.

**CAUTION:**

- Never damage the suspension arm with a jack.
- Check the stable condition when using a jack.

11. Remove stabilizer link. Refer to [RSU-35, "Removal and Installation"](#).

12. Remove upper link from suspension arm. Refer to [RSU-33, "Removal and Installation"](#).

13. Remove lower link from suspension arm. Refer to [RSU-31, "Removal and Installation"](#).

14. Remove coil spring from suspension arm. Refer to [RSU-27, "Removal and Installation"](#).

15. Remove suspension arm bracket from vehicle.

16. Remove suspension arm from suspension arm bracket.

17. Perform inspection after removal. Refer to [RSU-30, "Inspection"](#).

## INSTALLATION

Note the following, and install in the reverse order of removal.

- Perform final tightening of rear suspension member installation position (rubber bushing), under unladen conditions with tires on level ground.
- Never reuse suspension arm mounting nut.
- Perform inspection after installation. Refer to [RSU-30, "Inspection"](#).

## Inspection

INFOID:000000009752401

## INSPECTION AFTER REMOVAL

Check suspension arm and bushing for deformation, cracks or damage. Replace it if necessary.

## INSPECTION AFTER INSTALLATION

1. Check wheel sensor harness for proper connection. Refer to [BRC-133, "REAR WHEEL SENSOR : Exploded View"](#).
2. Adjust parking brake operation (stroke). Refer to [PB-3, "Inspection and Adjustment"](#).
3. Check wheel alignment. Refer to [RSU-22, "Inspection"](#).
4. Adjust neutral position of steering angle sensor. Refer to [BRC-62, "Work Procedure"](#).

# LOWER LINK

< REMOVAL AND INSTALLATION >

[AWD]

## LOWER LINK

### Exploded View

INFOID:000000009752402

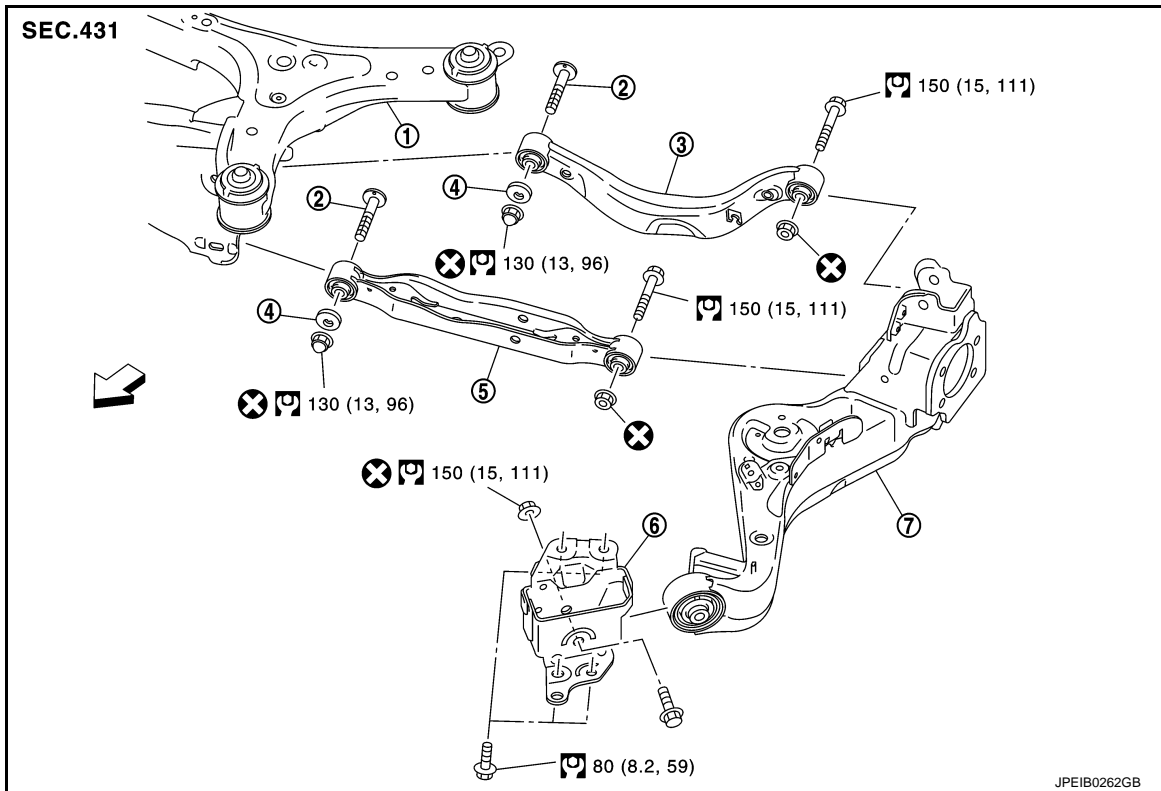

- |                           |                   |                           |
|---------------------------|-------------------|---------------------------|
| 1. Rear suspension member | 2. Adjusting bolt | 3. Upper link             |
| 4. Eccentric disk         | 5. Lower link     | 6. Suspension arm bracket |
| 7. Suspension arm         |                   |                           |

← Vehicle front

⊗: Always replace after every disassembly.

□: N·m (kg·m, ft·lb)

## Removal and Installation

INFOID:000000009752403

### REMOVAL

1. Remove tires with power tool. Refer to [WT-46. "Removal and Installation"](#).
2. Set jack under suspension arm.  
**CAUTION:**
  - Never damage the suspension arm with a jack.
  - Check the stable condition when using a jack.
3. Remove stabilizer link. Refer to [RSU-35. "Removal and Installation"](#).
4. Remove eccentric disc, adjusting bolt, mounting bolt, and nut, then remove lower link.
5. Perform inspection after removal. Refer to [RSU-32. "Inspection"](#).

### INSTALLATION

Note the following, and install in the reverse order of removal.

- Perform final tightening of rear suspension member and axle installation position (rubber bushing), under unladen conditions with tires on level ground.
- Never reuse lower link mounting nut.
- Perform inspection after installation. Refer to [RSU-32. "Inspection"](#).

## LOWER LINK

< REMOVAL AND INSTALLATION >

[AWD]

### Inspection

INFOID:000000009752404

#### INSPECTION AFTER REMOVAL

Check lower link and bushing for any deformation, cracks, or damage. Replace it if necessary.

#### INSPECTION AFTER INSTALLATION

1. Check wheel alignment. Refer to [RSU-22, "Inspection"](#).
2. Adjust neutral position of steering angle sensor. Refer to [BRC-62, "Work Procedure"](#).



# UPPER LINK

< REMOVAL AND INSTALLATION >

[AWD]

## UPPER LINK

### Exploded View

INFOID:000000009752405

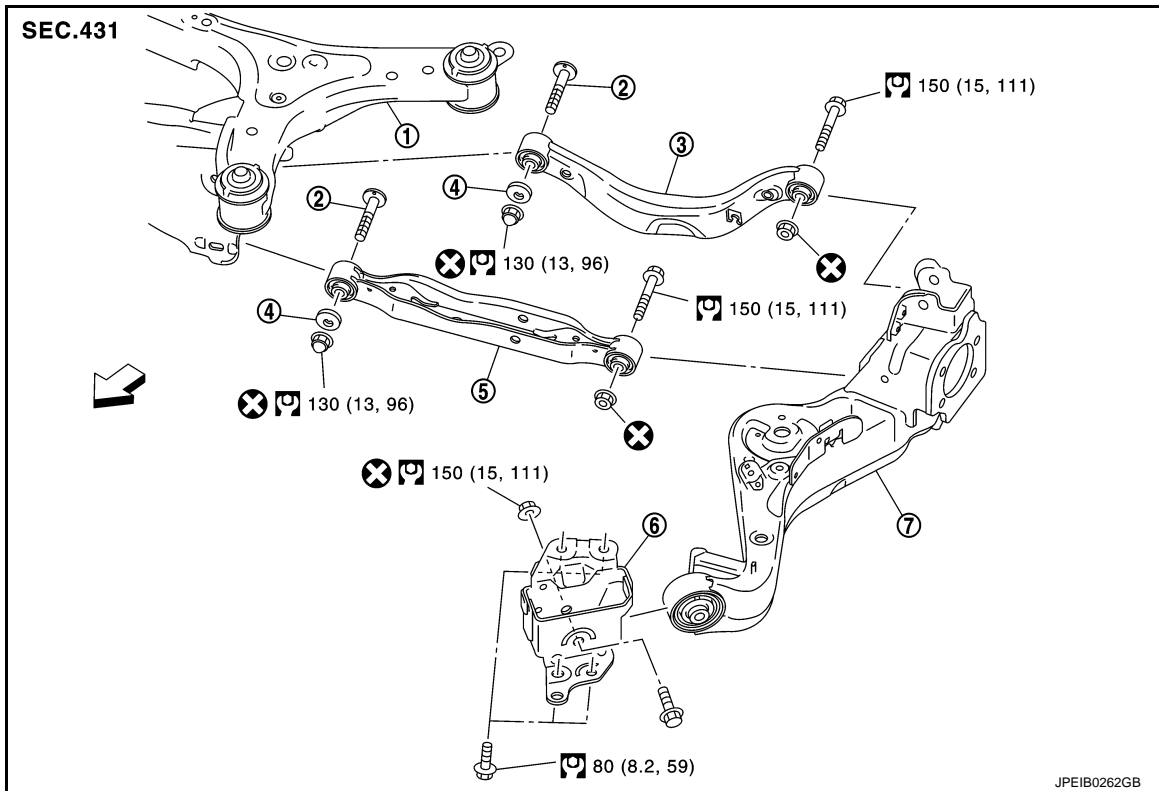

- |                           |                   |                           |
|---------------------------|-------------------|---------------------------|
| 1. Rear suspension member | 2. Adjusting bolt | 3. Upper link             |
| 4. Eccentric disk         | 5. Lower link     | 6. Suspension arm bracket |
| 7. Suspension arm         |                   |                           |

← Vehicle front

⊗: Always replace after every disassembly.

⊞: N·m (kg·m, ft·lb)

## Removal and Installation

INFOID:000000009752406

### REMOVAL

1. Remove tires with power tool. Refer to [WT-46, "Removal and Installation"](#).
2. Remove wheel sensor and sensor harness. Refer to [BRC-135, "REAR WHEEL SENSOR : Removal and Installation"](#).
3. Set jack under suspension arm.  
**CAUTION:**
  - Never damage the suspension arm with a jack.
  - Check the stable condition when using a jack.
4. Remove eccentric disc, adjusting bolt, mounting bolt, and nut, then remove upper link.
5. Perform inspection after removal. Refer to [RSU-34, "Inspection"](#).

### INSTALLATION

Note the following, and install in the reverse order of removal.

- Perform final tightening of rear suspension member and axle installation position (rubber bushing), under unladen conditions with tires on level ground.
- Never reuse upper link mounting nut.
- Perform inspection after installation. Refer to [RSU-34, "Inspection"](#).

## Inspection

INFOID:000000009752407

### INSPECTION AFTER REMOVAL

Check upper link and bushing for any deformation, cracks, or damage. Replace it if necessary.

### INSPECTION AFTER INSTALLATION

1. Check wheel sensor harness for proper connection. Refer to [BRC-133, "REAR WHEEL SENSOR : Exploded View"](#).
2. Check wheel alignment. Refer to [RSU-22, "Inspection"](#).
3. Adjust neutral position of steering angle sensor. Refer to [BRC-62, "Work Procedure"](#).

# REAR STABILIZER

< REMOVAL AND INSTALLATION >

[AWD]

## REAR STABILIZER

### Exploded View

INFOID:000000009752408

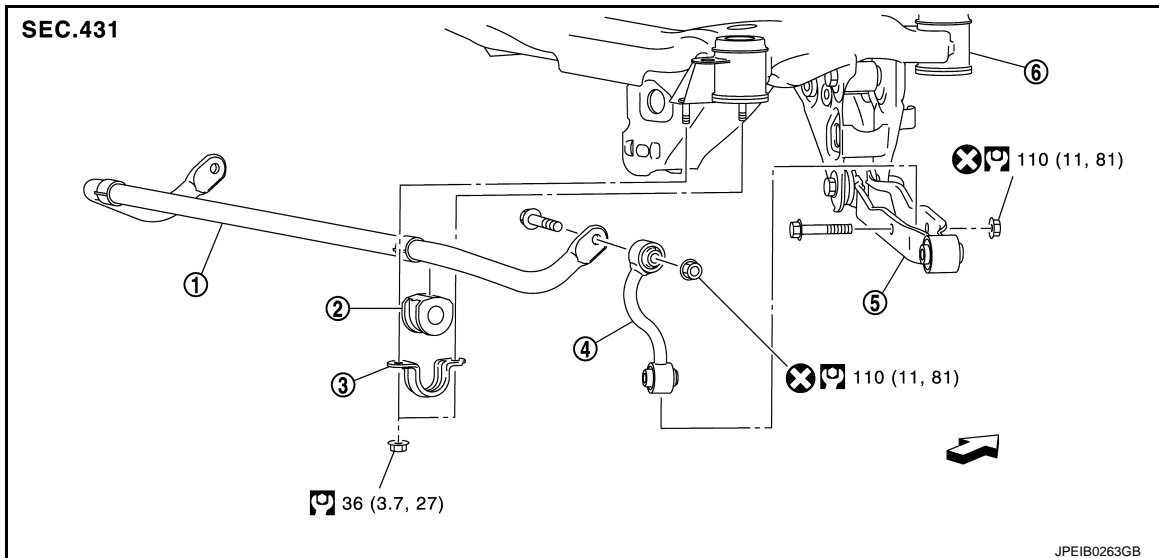

- |                    |               |                           |
|--------------------|---------------|---------------------------|
| 1. Stabilizer bar  | 2. Bushing    | 3. Stabilizer clamp       |
| 4. Stabilizer link | 5. Lower link | 6. Rear suspension member |

←: Vehicle front

⊗: Always replace after every disassembly.

⊞: N·m (kg·m, ft·lb)

## Removal and Installation

INFOID:000000009752409

### REMOVAL

1. Remove stabilizer link.
2. Remove center muffler. Refer to [EX-8. "Removal and Installation"](#).
3. Remove mounting nuts on stabilizer clamp, bushing, and stabilizer bar from suspension member.
4. Perform inspection after removal. Refer to [RSU-35. "Inspection"](#).

### INSTALLATION

Note the following, and install in the reverse order of removal.

- Perform final tightening of rear suspension member and axle installation position (rubber bushing), under unladen conditions with tires on level ground.
- Never reuse stabilizer link mounting nut.

### Inspection

INFOID:000000009752410

### INSPECTION AFTER REMOVAL

Check stabilizer bar, stabilizer link, stabilizer bushing and stabilizer clamp for deformation, cracks or damage. Replace it if necessary.

# REAR SUSPENSION ASSEMBLY

< REMOVAL AND INSTALLATION >

[AWD]

## REAR SUSPENSION ASSEMBLY

Exploded View

INFOID:000000009752411

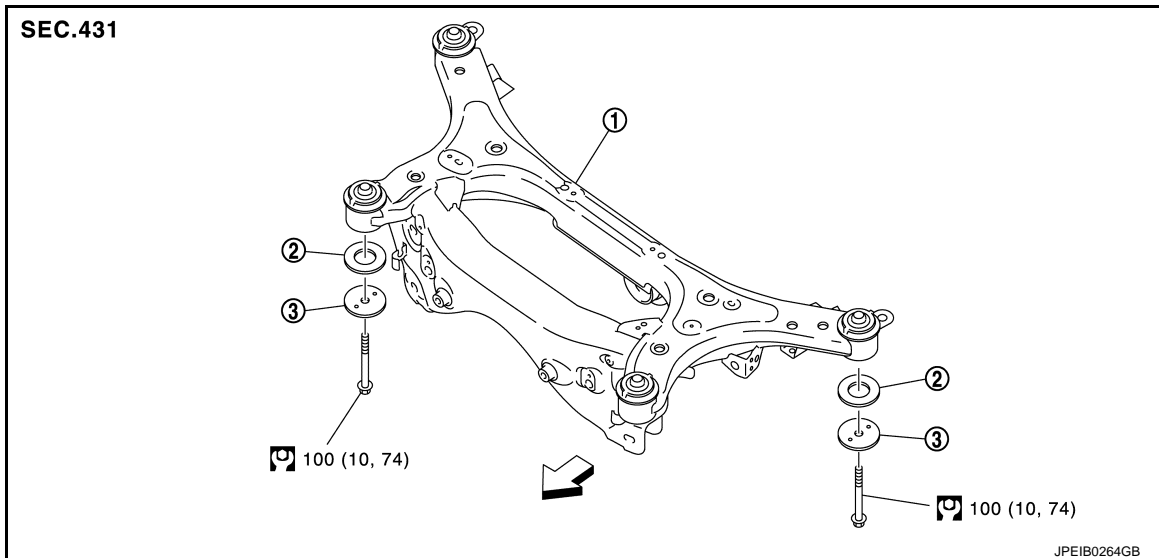

1. Rear suspension member      2. Rebound stopper      3. Washer

←: Vehicle front

: N·m (kg·m, ft·lb)

## Removal and Installation

INFOID:000000009752412

### REMOVAL

1. Remove tires with power tool. Refer to [WT-46, "Removal and Installation"](#).
2. Remove center muffler. Refer to [EX-8, "Removal and Installation"](#).
3. Remove propeller shaft. Refer to [DLN-123, "Removal and Installation"](#).
4. Remove stabilizer bar. Refer to [RSU-35, "Removal and Installation"](#).
5. Remove wheel sensor and sensor harness. Refer to [BRC-135, "REAR WHEEL SENSOR : Removal and Installation"](#).
6. Remove upper link from suspension arm. Refer to [RSU-33, "Removal and Installation"](#).
7. Remove lower link from suspension arm. Refer to [RSU-31, "Removal and Installation"](#).
8. Remove drive shaft from rear final drive. Refer to [RAX-19, "Removal and Installation"](#).
9. Remove rear final drive. Refer to [DLN-149, "Removal and Installation"](#).
10. Set jack under rear suspension member.

#### CAUTION:

- Never damage the suspension member with a jack.
- Check the stable condition when using a jack.

11. Remove rear suspension member mounting bolts, rebound stopper, and washer.
12. Slowly lower jack, then remove rear suspension member, lower link and upper link from vehicle as a unit.

#### CAUTION:

Operate while checking that jack supporting status is stable.

13. Remove lower link and upper link from rear suspension member.
14. Perform inspection after removal. Refer to [RSU-37, "Inspection"](#).

### INSTALLATION

Note the following, and install in the reverse order of the removal.

# REAR SUSPENSION ASSEMBLY

[AWD]

## < REMOVAL AND INSTALLATION >

- To install mounting bolts of the suspension member, temporarily tighten them in numerical order shown in the figure and tighten them to the specified torque.

← : Vehicle front

- Perform the final tightening of each parts removed when removing rear suspension assembly under unladen conditions.
- Perform inspection after installation. Refer to [RSU-37, "Inspection"](#).

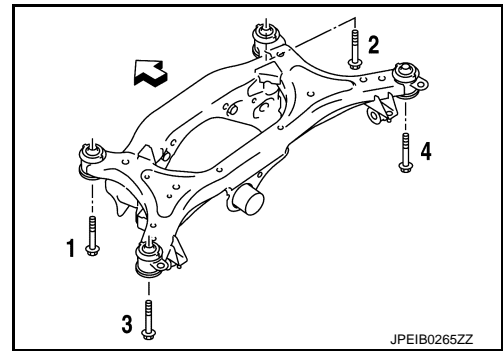

INFOID:000000009752413

## Inspection

### INSPECTION AFTER REMOVAL

Check rear suspension member for deformation, cracks, or any other damage. Replace it if necessary.

### INSPECTION AFTER INSTALLATION

- Check wheel sensor harness for proper connection. Refer to [BRC-133, "REAR WHEEL SENSOR : Exploded View"](#).
- Check wheel alignment. Refer to [RSU-22, "Inspection"](#).
- Adjust neutral position of steering angle sensor. Refer to [BRC-62, "Work Procedure"](#).

A  
B  
C  
D  
F  
G  
H  
I  
J  
K  
L  
M  
N  
O  
P

RSU

# SERVICE DATA AND SPECIFICATIONS (SDS)

< SERVICE DATA AND SPECIFICATIONS (SDS)

[AWD]

## SERVICE DATA AND SPECIFICATIONS (SDS)

### SERVICE DATA AND SPECIFICATIONS (SDS)

#### Wheel Alignment

INFOID:000000009752414

#### FOR USA MODELS

Item		Standard	NISMO RS	
Tire Size		17 inch	18 inch	
Camber Degree minute (Decimal degree)	Minimum	-0° 45' (-0.75°)	-0° 41' (-0.68°)	
	Nominal	0° 00' (0.00°)	0° 4' (0.07°)	
	Maximum	0° 45' (0.75°)	0° 49' (0.81°)	
Toe-in	Total toe-in Distance	Minimum	In 1.0 mm (In 0.04 in)	
		Nominal	In 3.0 mm (In 0.12 in)	
		Maximum	In 5.0 mm (In 0.20 in)	
	Total toe-angle Degree minute (Decimal degree)	Minimum	In 0° 06' 00" (In 0.10°)	In 0° 11' 00" (In 0.18°)
		Nominal	In 0° 16' 00" (In 0.27°)	In 0° 21' 00" (In 0.35°)
		Maximum	In 0° 26' 00" (In 0.43°)	In 0° 31' 00" (In 0.52°)

Measure value under unladen\* conditions.

\*: Fuel, engine coolant and lubricant are full. Spare tire, jack, hand tools and mats are in designated positions.

#### FOR CANADA MODELS

Item		Standard	NISMO RS	
Tire Size		17 inch	18 inch	
Camber Degree minute (Decimal degree)	Minimum	-0° 43' (-0.71°)		
	Nominal	0° 02' (0.03°)		
	Maximum	0° 47' (0.78°)		
Toe-in	Total toe-in Distance	Minimum	In 1.0 mm (In 0.04 in)	
		Nominal	In 3.0 mm (In 0.12 in)	
		Maximum	In 5.0 mm (In 0.20 in)	
	Total toe-angle Degree minute (Decimal degree)	Minimum	In 0° 05' 00" (In 0.08°)	In 0° 07' 00" (In 0.12°)
		Nominal	In 0° 15' 00" (In 0.25°)	In 0° 17' 00" (In 0.28°)
		Maximum	In 0° 25' 00" (In 0.42°)	In 0° 27' 00" (In 0.45°)

Measure value under unladen\* conditions.

\*: Fuel, engine coolant and lubricant are full. Spare tire, jack, hand tools and mats are in designated positions.

#### Wheelarch Height

INFOID:000000009752415

#### FOR USA MODELS

Item	Standard	NISMO RS
Tire Size	17 inch	18 inch
Front (Hf)	734 mm (28.90 in)	724 mm (28.50 in)

# SERVICE DATA AND SPECIFICATIONS (SDS)

< SERVICE DATA AND SPECIFICATIONS (SDS)

[AWD]

Item	Standard	NISMO RS
Tire Size	17 inch	18 inch
Rear (Hr)	741 mm (29.17 in)	735 mm (28.94 in)

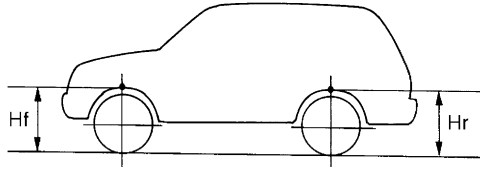

SFA746B

Measure value under unladen\* conditions.

\*: Fuel, engine coolant and lubricant are full. Spare tire, jack, hand tools and mats are in designated positions.

## FOR CANADA MODELS

Item	Standard	NISMO RS
Tire Size	17 inch	18 inch
Front (Hf)	735 mm (28.94 in)	724 mm (28.50 in)
Rear (Hr)	741 mm (29.17 in)	735 mm (28.94 in)

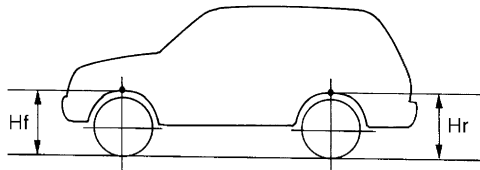

SFA746B

Measure value under unladen\* conditions.

\*: Fuel, engine coolant and lubricant are full. Spare tire, jack, hand tools and mats are in designated positions.

A  
B  
C  
D  
F  
G  
H  
I  
J  
K  
L  
M  
N  
O  
P

RSU