

**SECTION** **ST**  
**STEERING SYSTEM**

A  
 B  
 C  
 D  
 E  
 F  
**ST**  
 H  
 I  
 J  
 K  
 L  
 M  
 N  
 O  
 P

**CONTENTS**

<p><b>PRECAUTION</b> ..... 2</p> <p><b>PRECAUTIONS</b> ..... 2</p> <p style="padding-left: 20px;">Precaution for Supplemental Restraint System (SRS) "AIR BAG" and "SEAT BELT PRE-TENSIONER" .....2</p> <p style="padding-left: 20px;">Service Notice or Precautions for Steering System .....2</p> <p style="padding-left: 40px;">.....2</p> <p style="padding-left: 20px;">Precautions for Removing of Battery Terminal .....3</p> <p><b>PREPARATION</b> ..... 4</p> <p><b>PREPARATION</b> ..... 4</p> <p style="padding-left: 20px;">Special Service Tools .....4</p> <p style="padding-left: 20px;">Commercial Service Tools .....4</p> <p><b>BASIC INSPECTION</b> ..... 5</p> <p><b>STEERING WHEEL</b> ..... 5</p> <p style="padding-left: 20px;">Inspection .....5</p> <p><b>SYMPTOM DIAGNOSIS</b> ..... 7</p> <p><b>NOISE, VIBRATION AND HARSHNESS (NVH) TROUBLESHOOTING</b> ..... 7</p> <p style="padding-left: 20px;">NVH Troubleshooting Chart .....7</p> <p><b>PERIODIC MAINTENANCE</b> ..... 8</p> <p><b>STEERING WHEEL</b> ..... 8</p> <p style="padding-left: 20px;">Inspection .....8</p>	<p><b>REMOVAL AND INSTALLATION</b> ..... 9</p> <p><b>STEERING WHEEL</b> ..... 9</p> <p style="padding-left: 20px;">Exploded View ..... 9</p> <p style="padding-left: 20px;">Removal and Installation ..... 9</p> <p><b>STEERING COLUMN</b> .....10</p> <p style="padding-left: 20px;">Exploded View .....10</p> <p style="padding-left: 20px;">Removal and Installation .....11</p> <p style="padding-left: 20px;">Inspection .....12</p> <p><b>STEERING SHAFT</b> .....14</p> <p style="padding-left: 20px;">Exploded View .....14</p> <p style="padding-left: 20px;">Removal and Installation .....14</p> <p style="padding-left: 20px;">Inspection .....15</p> <p><b>STEERING GEAR AND LINKAGE</b> .....16</p> <p style="padding-left: 20px;">Exploded View .....16</p> <p style="padding-left: 20px;">Removal and Installation .....17</p> <p style="padding-left: 20px;">Disassembly and Assembly .....18</p> <p style="padding-left: 20px;">Inspection .....19</p> <p><b>SERVICE DATA AND SPECIFICATIONS (SDS)</b> .....21</p> <p><b>SERVICE DATA AND SPECIFICATIONS (SDS)</b> .....21</p> <p style="padding-left: 20px;">General Specifications .....21</p> <p style="padding-left: 20px;">Steering Wheel .....21</p> <p style="padding-left: 20px;">Steering Angle .....21</p> <p style="padding-left: 20px;">Steering Column .....21</p> <p style="padding-left: 20px;">Steering Gear and Linkage .....21</p>
--	--

# PRECAUTIONS

< PRECAUTION >

## PRECAUTION

### PRECAUTIONS

#### Precaution for Supplemental Restraint System (SRS) "AIR BAG" and "SEAT BELT PRE-TENSIONER"

INFOID:000000009752417

The Supplemental Restraint System such as "AIR BAG" and "SEAT BELT PRE-TENSIONER", used along with a front seat belt, helps to reduce the risk or severity of injury to the driver and front passenger for certain types of collision. This system includes seat belt switch inputs and dual stage front air bag modules. The SRS system uses the seat belt switches to determine the front air bag deployment, and may only deploy one front air bag, depending on the severity of a collision and whether the front occupants are belted or unbelted. Information necessary to service the system safely is included in the "SRS AIR BAG" and "SEAT BELT" of this Service Manual.

#### **WARNING:**

Always observe the following items for preventing accidental activation.

- To avoid rendering the SRS inoperative, which could increase the risk of personal injury or death in the event of a collision that would result in air bag inflation, all maintenance must be performed by an authorized NISSAN/INFINITI dealer.
- Improper maintenance, including incorrect removal and installation of the SRS, can lead to personal injury caused by unintentional activation of the system. For removal of Spiral Cable and Air Bag Module, see "SRS AIR BAG".
- Never use electrical test equipment on any circuit related to the SRS unless instructed to in this Service Manual. SRS wiring harnesses can be identified by yellow and/or orange harnesses or harness connectors.

#### PRECAUTIONS WHEN USING POWER TOOLS (AIR OR ELECTRIC) AND HAMMERS

#### **WARNING:**

Always observe the following items for preventing accidental activation.

- When working near the Air Bag Diagnosis Sensor Unit or other Air Bag System sensors with the ignition ON or engine running, never use air or electric power tools or strike near the sensor(s) with a hammer. Heavy vibration could activate the sensor(s) and deploy the air bag(s), possibly causing serious injury.
- When using air or electric power tools or hammers, always switch the ignition OFF, disconnect the battery, and wait at least 3 minutes before performing any service.

#### Service Notice or Precautions for Steering System

INFOID:000000009752418

- In case of removing steering gear assembly, make the final tightening with grounded and unloaded vehicle condition, and then check wheel alignment.
- Observe the following precautions when disassembling.
  - Before disassembly, thoroughly clean the outside of the unit.
  - Disassembly should be done in a clean work area. It is important to prevent the internal parts from becoming contaminated by dirt or other foreign matter.
  - For easier and proper assembly, place disassembled parts in order on a parts rack.
  - Use nylon cloth or paper towels to clean the parts; common shop rags can leave lint that might interfere with their operation.
  - Never reuse non-reusable parts.
  - Before assembling, apply the specified grease to the directed parts.
- During quick steering, rasping noise may be heard from around the steering wheel. This is not a malfunction. The noise is an operating noise of the EPS system under normal conditions. If the rasping noise occurs during slow steering, this may not be an operating noise of the system. In this case, it is necessary to find out the location of the noise and repair, if necessary.
- Never repeat static steering. (Motor and EPS control unit could be heated.)

# PRECAUTIONS

< PRECAUTION >

## Precautions for Removing of Battery Terminal

INFOID:000000010198937

- When removing the 12V battery terminal, turn OFF the ignition switch and wait at least 30 seconds.

**NOTE:**

ECU may be active for several tens of seconds after the ignition switch is turned OFF. If the battery terminal is removed before ECU stops, then a DTC detection error or ECU data corruption may occur.

- For vehicles with the 2-batteries, be sure to connect the main battery and the sub battery before turning ON the ignition switch.

**NOTE:**

If the ignition switch is turned ON with any one of the terminals of main battery and sub battery disconnected, then DTC may be detected.

- After installing the 12V battery, always check "Self Diagnosis Result" of all ECUs and erase DTC.

**NOTE:**

The removal of 12V battery may cause a DTC detection error.

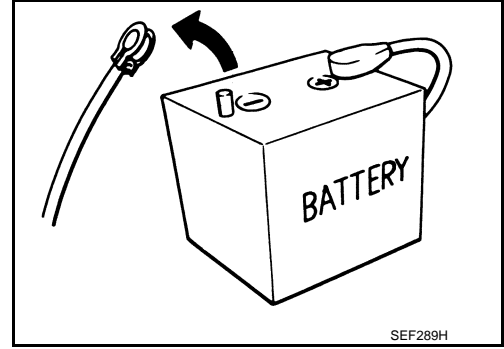

A  
B  
C  
D  
E  
F  
ST  
H  
I  
J  
K  
L  
M  
N  
O  
P

# PREPARATION

< PREPARATION >

## PREPARATION

### PREPARATION

#### Special Service Tools

INFOID:000000009752419

The actual shapes of Kent-Moore tools may differ from those of special service tools illustrated here.

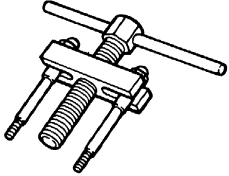
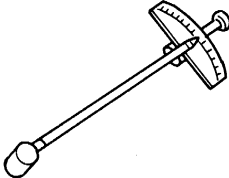
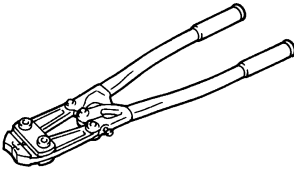
Tool number (Kent-Moore No.) Tool name	Description
ST27180001 (J-25726-A) Steering wheel puller   ZZA0819D	Removing steering wheel
ST3127S000 (J-25765-A) Preload gauge   ZZA0806D	Measuring steering column rotating torque
KV40107300 ( — ) Boot band crimping tool   ZZA1229D	Installing boot clamp (large diameter)

#### Commercial Service Tools

INFOID:000000009752420

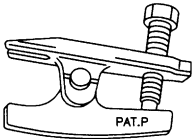
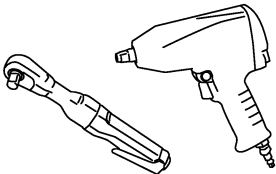
Tool name	Description
Ball joint remover   S-NT146	Removing steering outer socket
Power tool   PBIC0190E	Loosening bolts and nuts

# STEERING WHEEL

< BASIC INSPECTION >

## BASIC INSPECTION

### STEERING WHEEL

#### Inspection

INFOID:000000009752421

#### NEUTRAL POSITION STEERING WHEEL

1. Make sure that steering gear assembly, steering column assembly and steering wheel are installed in the correct position.
2. Perform neutral position inspection after wheel alignment. Refer to [FSU-7, "Inspection"](#).
3. Set vehicle to the straight-ahead position and confirm steering wheel is in the neutral position.
4. Loosen outer socket lock nut and turn inner socket to left and right equally to make fine adjustments if steering wheel is not in the neutral position.

#### STEERING WHEEL TURNING FORCE

1. Park vehicle on a level and dry surface, set parking brake.
2. Tires need to be inflated normal pressure. Refer to [WT-54, "Tire Air Pressure"](#).
3. Start engine.
4. Check steering wheel turning force when steering wheel has been turned 360° from neutral position.

**Steering wheel turning force**

: Refer to [ST-21, "Steering Wheel"](#).

**L : 185 mm (7.28 in)**

**NOTE:**

Multiply the distance from the hook of spring balance to the center of steering wheel by the measurement value with a spring balance.

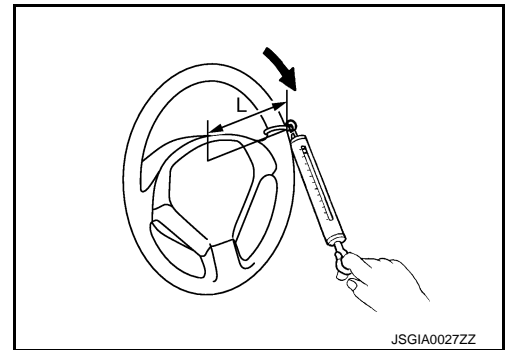

#### FRONT WHEEL TURNING ANGLE

1. Check front wheel turning angle after toe-in inspection. Refer to [FSU-7, "Inspection"](#).
2. Place front wheels on turning radius gauges and rear wheels on stands, so that vehicle can be level.
3. Check the maximum inner and outer wheel turning angles for LH and RH road wheels.

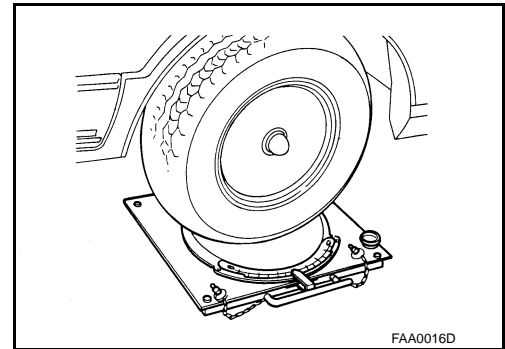

4. With the engine at idle, turn steering wheel from full left stop to full right stop and measure the turning angles.

**Inner wheel (Angle: A) : Refer to [ST-21, "Steering Angle"](#).**

**Outer wheel (Angle: B) : Refer to [ST-21, "Steering Angle"](#).**

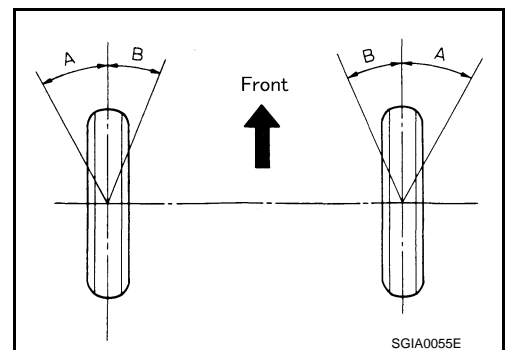

## STEERING WHEEL

### < BASIC INSPECTION >

5. Check the following items when turning angle is out of the standard.
  - a. Check rack stroke (L).

**Rack stroke neutral position (L)** : Refer to [ST-21, "Steering Gear and Linkage"](#).

- b. If rack stroke is out of specification, replace steering gear assembly.
  - Steering angles are not adjustable. Check steering gear assembly, steering column assembly, and front suspension components for wear or damage if any of the turning angles are different from the specified value. Replace any of them, if any non-standard condition exists.

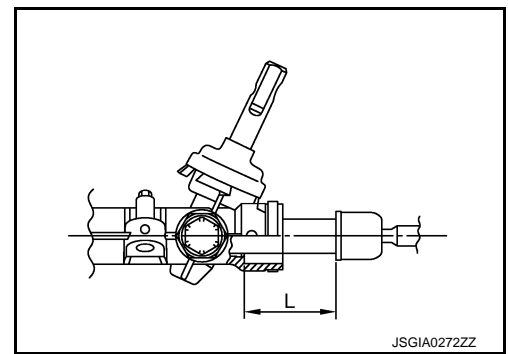

# NOISE, VIBRATION AND HARSHNESS (NVH) TROUBLESHOOTING

< SYMPTOM DIAGNOSIS >

## SYMPTOM DIAGNOSIS

### NOISE, VIBRATION AND HARSHNESS (NVH) TROUBLESHOOTING

#### NVH Troubleshooting Chart

INFOID:000000009752422

Use the chart below to find the cause of the symptom. If necessary, repair or replace these parts.

Symptom	Steering	Possible cause and SUSPECTED PARTS															
		Outer/inner socket ball joint swinging torque	Outer/inner socket ball joint rotating torque	Outer/inner socket ball joint end play	Steering wheel play	Improper steering wheel	Improper installation or looseness of tilt lock lever	Mounting looseness	Steering column deformation or damage	Improper installation or looseness of steering column	Steering linkage looseness	AXLE and SUSPENSION	TIRE	ROAD WHEEL	DRIVE SHAFT	BRAKE	
Noise	Steering	Noise	x	x	x	x				x	x		x	x	x	x	x
		Shake					x	x	x				x	x	x	x	x
		Vibration					x	x	x	x			x	x		x	
		Shimmy					x		x			x	x	x	x		x
		Judder						x	x			x	x	x	x		x
Reference			<a href="#">ST-19, "Inspection"</a>	<a href="#">ST-19, "Inspection"</a>	<a href="#">ST-19, "Inspection"</a>	<a href="#">ST-8, "Inspection"</a>	<a href="#">ST-8, "Inspection"</a>	—	<a href="#">ST-16, "Exploded View"</a>	<a href="#">ST-12, "Inspection"</a>	<a href="#">ST-10, "Exploded View"</a>	<a href="#">ST-16, "Exploded View"</a>	NVH in FAX, RAX, FSU, RSU section	NVH in WT section	NVH in WT section	NVH in FAX section	NVH in BR section

x: Applicable

A  
B  
C  
D  
E  
F  
ST  
H  
I  
J  
K  
L  
M  
N  
O  
P

# STEERING WHEEL

< PERIODIC MAINTENANCE >

## PERIODIC MAINTENANCE

### STEERING WHEEL

#### Inspection

INFOID:000000009752423

#### STEERING WHEEL AXIAL END PLAY

1. Check installation conditions of steering gear assembly, front suspension assembly, axle and steering column assembly.
2. Check if movement exists when steering wheel is moved up and down, to the left and right and to the axial direction.

**Steering wheel axial end play** : Refer to [ST-21, "Steering Wheel"](#).

3. Check the following items when steering wheel axial end play is out of the standard.
  - Check the steering column assembly mounting condition. Refer to [ST-10, "Exploded View"](#).
  - Check steering gear assembly mounting condition for looseness. Refer to [ST-16, "Exploded View"](#).

#### STEERING WHEEL PLAY

1. Turn steering wheel so that front wheels come to the straight-ahead position.
2. Start engine and lightly turn steering wheel to the left and right until front wheels start to move.
3. Measure steering wheel movement on the outer circumference.

**Steering wheel play on the outer circumference** : Refer to [ST-21, "Steering Wheel"](#).

4. Check the following items when steering wheel play is out of the standard.
  - Check backlash for each joint of steering column assembly.
  - Check installation condition of steering gear assembly.



# STEERING WHEEL

< REMOVAL AND INSTALLATION >

## REMOVAL AND INSTALLATION

### STEERING WHEEL

Exploded View

INFOID:000000009752424

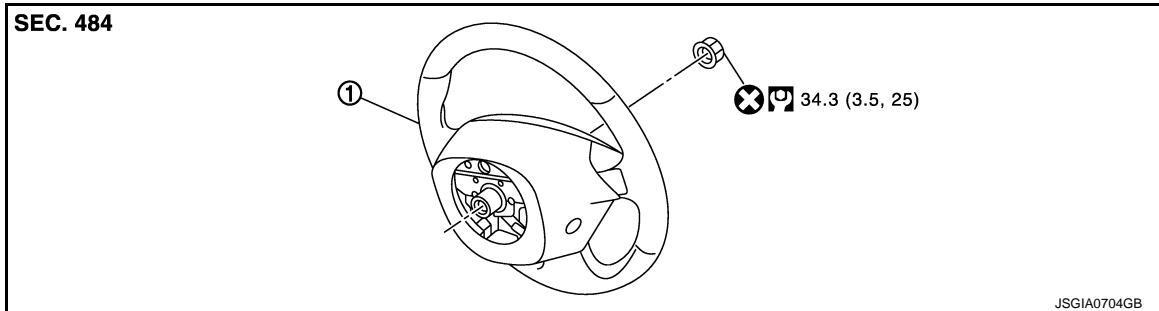

1. Steering wheel

 Always replace after every disassembly.

 N·m (kg-m, ft-lb)

### Removal and Installation

INFOID:000000009752425

#### REMOVAL

##### NOTE:

When reconnecting spiral cable, fix cable with a tape so that fixing case and rotating part keep aligned. This will omit neutral position alignment procedure during spiral cable installation.

1. Set vehicle to the straight-ahead position.
2. Remove driver air bag module. Refer to [SR-11, "Removal and Installation"](#).
3. Remove steering wheel lock nut after steering is locked.
4. Remove steering wheel with the steering wheel puller (A) [SST: ST27180001 (J-25726-A)].

##### NOTE:

Put paint marks on the steering wheel and the column shaft head for supporting accurate positioning during the installation procedure.

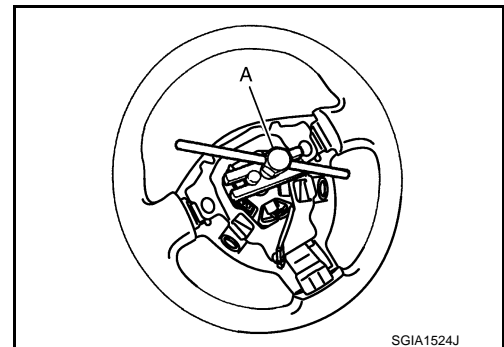

#### INSTALLATION

Note the following, and install in the reverse order of removal.

- Check the spiral cable neutral position after replacing or rotating spiral cable. Refer to [SR-14, "Removal and Installation"](#).

##### CAUTION:

- Never twist spiral cable excessively after it becomes tight. (Twisting may cause the cable to be torn off.)
- Never reuse steering wheel lock nut.

# STEERING COLUMN

< REMOVAL AND INSTALLATION >

## STEERING COLUMN

Exploded View

INFOID:00000009752426

(Except for NISMO RS 2WD)

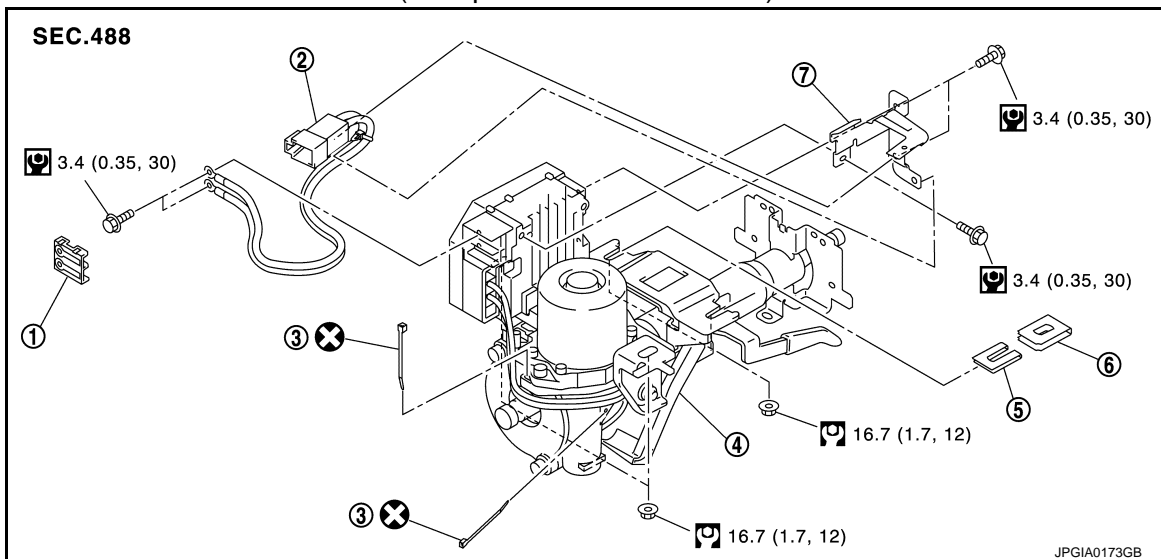

- |                             |                        |                        |
|-----------------------------|------------------------|------------------------|
| 1. Cover                    | 2. Sub-harness         | 3. Band                |
| 4. Steering column assembly | 5. Slide plate (inner) | 6. Slide plate (outer) |
| 7. Bracket                  |                        |                        |

⊗: Always replace after every disassembly.

☐: N-m (kg-m, ft-lb)

☐: N-m (kg-m, in-lb)

(For NISMO RS 2WD)

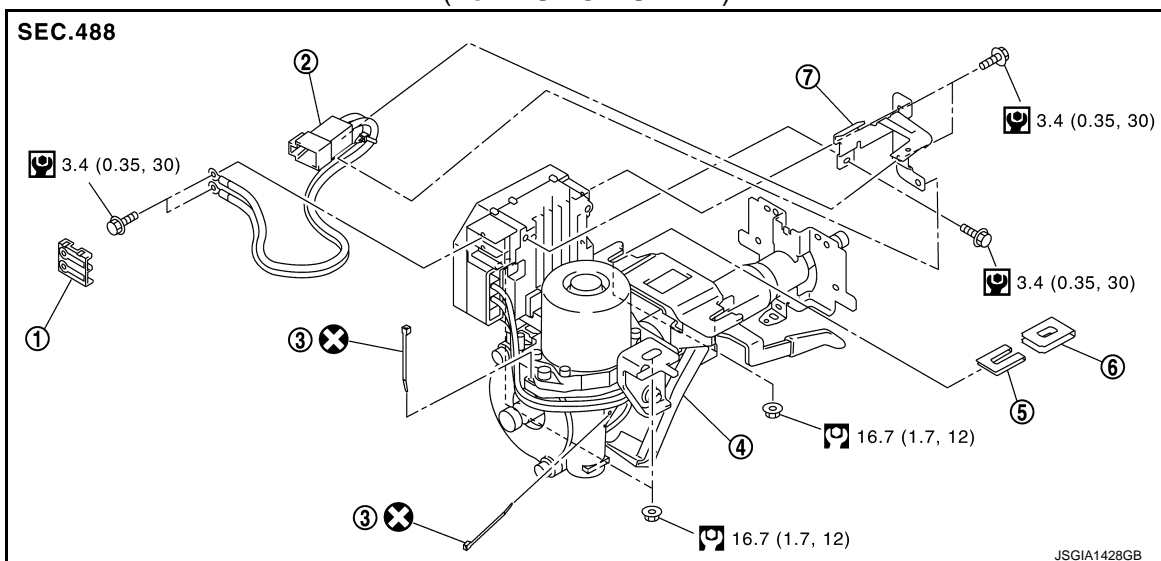



- |                             |                        |                        |
|-----------------------------|------------------------|------------------------|
| 1. Cover                    | 2. Sub-harness         | 3. Band                |
| 4. Steering column assembly | 5. Slide plate (inner) | 6. Slide plate (outer) |
| 7. Bracket                  |                        |                        |

⊗: Always replace after every disassembly.

# STEERING COLUMN

## < REMOVAL AND INSTALLATION >

: N·m (kg-m, ft-lb)

: N·m (kg-m, in-lb)

## Removal and Installation

INFOID:000000009752427

### REMOVAL

#### CAUTION:

- While removing the steering column assembly, never unlock the tilt lever.
- Never impact on the axis when removing steering column assembly.
- Be careful when removing steering column assembly from the vehicle because it is heavy.
- Keep steering column assembly away from magnetic sources.
- Never disassemble steering column assembly. It is not separable.
- While removing the steering column assembly, never move the steering gear.
- When removing the steering column assembly, be careful not to allow the intermediate shaft to turn.

1. Set vehicle to the straight-ahead position.
2. Place the tilt to the lowest level.
3. Remove instrument lower panel. Refer to [IP-13, "Removal and Installation"](#).
4. Remove driver air bag module. Refer to [SR-11, "Removal and Installation"](#).
5. Remove steering wheel. Refer to [ST-9, "Removal and Installation"](#).
6. Remove steering column cover. Refer to [IP-13, "Removal and Installation"](#).
7. Remove spiral cable. Refer to [SR-14, "Removal and Installation"](#).
8. Remove combination switch.
  - Without intelligent key system: Refer to [BCS-158, "Removal and Installation"](#).
  - With intelligent key system: Refer to [BCS-91, "Removal and Installation"](#).
9. Disconnect each switch harness connectors installed to steering column assembly.
10. Remove intermediate shaft mounting bolt (steering column side), and separate intermediate shaft from steering column assembly. Refer to [ST-14, "Removal and Installation"](#).

#### CAUTION:

- Place a matching mark on both intermediate shaft and steering column assembly before removing intermediate shaft.
  - When removing intermediate shaft, never insert a tool, such as a screwdriver, into the yoke groove to pull out the intermediate shaft. In case of the violation of the above, replace intermediate shaft with a new one.
11. Disconnect EPS control unit connectors.
  12. Remove steering column assembly.

#### CAUTION:

When removing the mounting, be careful not to drop the steering column assembly.
  13. Remove slide plate (outer and inner) from steering column assembly.
  14. Remove cover, sub-harness, band, and bracket from steering column assembly.

#### CAUTION:

Remove cover, sub-harness, band, and bracket only when necessary.
  15. Perform inspection after removal. Refer to [ST-12, "Inspection"](#).

### INSTALLATION

#### CAUTION:

- Never impact on the axis when removing steering column assembly.
  - When installing the steering column cover, check that the vehicle harness is not stuck in the cover.
- Note the following, and install in the reverse order of removal.

# STEERING COLUMN

## < REMOVAL AND INSTALLATION >

- After tightening mounting nut (A) of the steering column assembly, press in slide plate (outer and inner) (1) to tighten mounting nut (B).

**CAUTION:**

The slide plate must be securely pressed in before tightening the nut of slide plate (outer, inner).

- For intermediate shaft mounting bolt direction, refer to [ST-14, "Exploded View"](#). (Do not insert it from the other side.)

**CAUTION:**

Never reuse intermediate shaft mounting bolt.

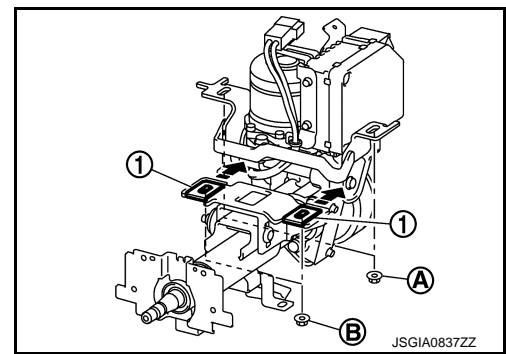

- When connecting intermediate shaft upper side (1) and column shaft, make sure the bolt is securely seated in groove (A) of column shaft (A) before final tightening.
- After installing steering column assembly, perform self-diagnosis with CONSULT to ensure correct operation. Refer to [STC-9, "CONSULT Function"](#).
- Never reuse band.
- Perform inspection after installation. Refer to [ST-12, "Inspection"](#).

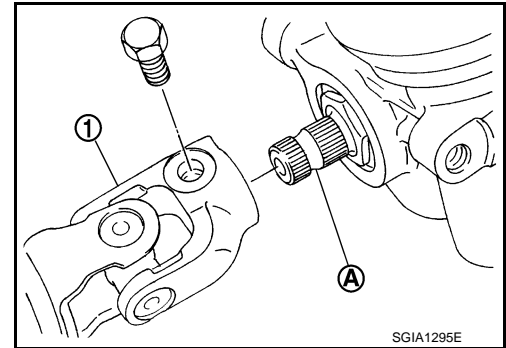

## Inspection

INFOID:000000009752428

### INSPECTION AFTER REMOVAL

- Check each part of steering column assembly for damage or other malfunctions. Replace if there are any abnormal conditions.
- Measure steering column assembly rotating torque using a preload gauge (A) [SST: ST3127S000 (J-25765-A)]. Replace steering column assembly if the rotating torque is outside the standard.

**Rotating torque** : Refer to [ST-21, "Steering Column"](#).

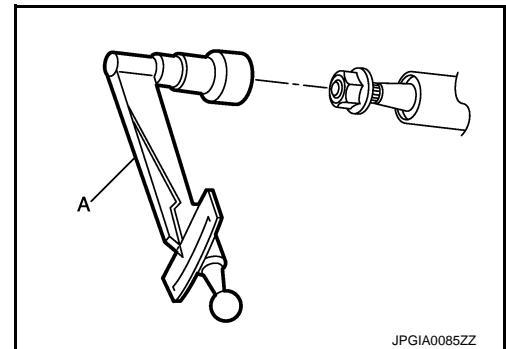

- Measure the length "L" shown in the figure, if vehicle has been involved in a minor collision. Replace steering column assembly (with motor, reduction gear, sensor) if "L" is outside the standard.

**Steering column length (L)** : Refer to [ST-21, "Steering Column"](#).

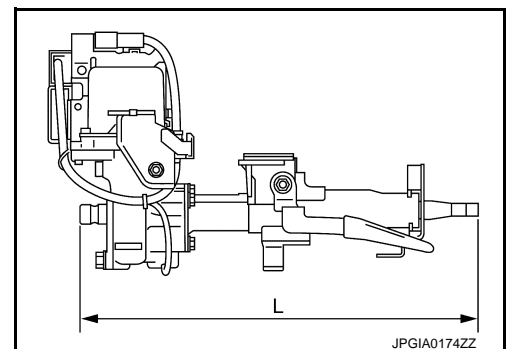

### INSPECTION AFTER INSTALLATION

- Check each part of steering column assembly for damage or other malfunctions. Replace if there are any abnormal conditions.
- Check the steering wheel play, neutral position steering wheel, steering wheel turning force, and front wheel turning angle. Refer to [ST-8, "Inspection"](#).

# STEERING COLUMN

## < REMOVAL AND INSTALLATION >

- Check tilt mechanism operating range "T" shown in the figure.

**Tilt operating range (T)**

**: Refer to [ST-21](#). "[Steering Column](#)".**

- Adjust neutral position of steering angle sensor. Refer to [BRC-62](#). "[Work Procedure](#)".

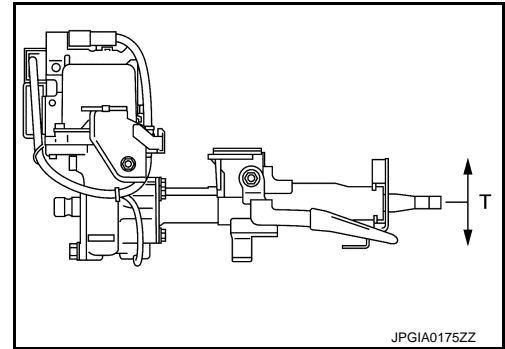

A  
B  
C  
D  
E  
F  
ST  
H  
I  
J  
K  
L  
M  
N  
O  
P

# STEERING SHAFT

< REMOVAL AND INSTALLATION >

## STEERING SHAFT

Exploded View

INFOID:000000009752429

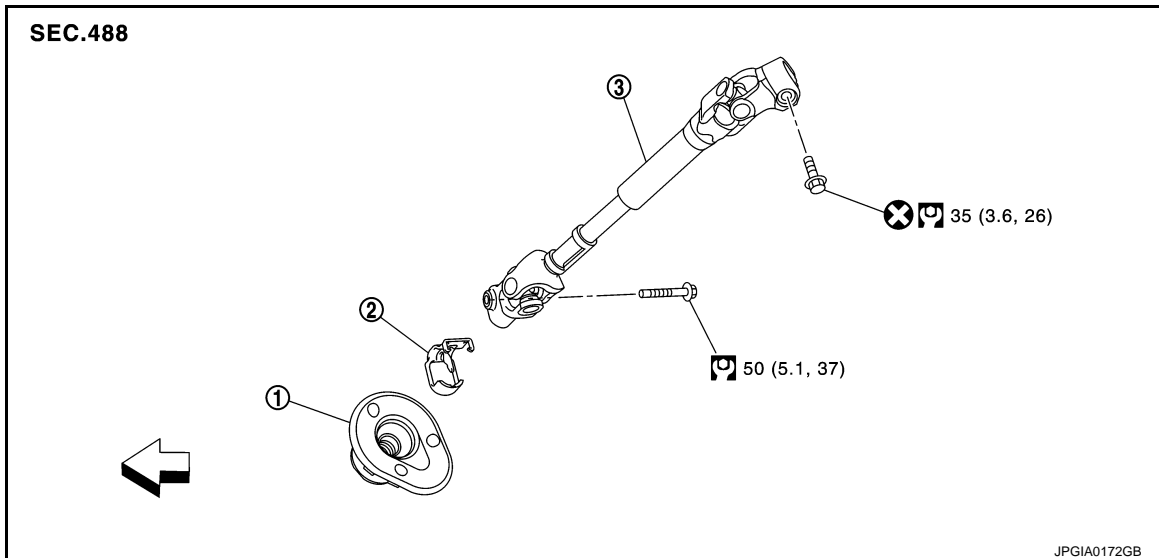

1. Dash seal                                      2. Guide\*                                      3. Intermediate shaft

⇐: Vehicle front

⊗: Always replace after every disassembly.

⊞: N·m (kg·m, ft·lb)

\*: If reinstalling, this part is not required.

## Removal and Installation

INFOID:000000009752430

### REMOVAL

#### CAUTION:

Spiral cable may be cut if steering wheel turns while separating steering column assembly and steering gear assembly. Be sure to secure steering wheel using string to avoid turning.

1. Set vehicle to the straight-ahead position.
2. Place the tilt to the lowest level.
3. Remove instrument lower panel. Refer to [IP-13, "Removal and Installation"](#).
4. Remove intermediate shaft mounting bolt (steering gear side), and separate intermediate shaft from steering gear assembly.

#### CAUTION:

- Place a matching mark on both intermediate shaft and steering gear assembly before removing intermediate shaft.
- When removing intermediate shaft, never insert a tool, such as a screwdriver, into the yoke groove to pull out the intermediate shaft. In case of the violation of the above, replace intermediate shaft with a new one.

5. Remove intermediate shaft mounting bolt (steering column side), and remove intermediate shaft from steering column assembly.

#### CAUTION:

- Place a matching mark on both intermediate shaft and steering column assembly before removing intermediate shaft.
- When removing intermediate shaft, never insert a tool, such as a screwdriver, into the yoke groove to pull out the intermediate shaft. In case of the violation of the above, replace intermediate shaft with a new one.

6. Remove dash seal from vehicle.
7. Remove guide from intermediate shaft.

# STEERING SHAFT

## < REMOVAL AND INSTALLATION >

### CAUTION:

Remove guide only when necessary.

8. Perform inspection after removal. Refer to [ST-15, "Inspection"](#).

## INSTALLATION

### CAUTION:

Spiral cable may be cut if steering wheel turns while separating steering column assembly and steering gear assembly. Be sure to secure steering wheel using string to avoid turning.

Note the following, and install in the reverse order of removal.

- To install dash seal (1) to the vehicle, insert dash seal into the steering gear assembly and press in the protrusions (A) by hand.

### CAUTION:

Never allow dash seal lip to run off the engine room side or passenger room side.

- Follow the instructions below to install intermediate shaft to steering gear assembly.
- Insert intermediate shaft into steering gear assembly. Align groove of the steering gear assembly with the bolt hole of the intermediate shaft.

### CAUTION:

The guide protrusion is not required to be reinstalled.

- Check for galling while hand-tightening the mounting bolt of intermediate shaft (steering gear assembly side). After checking that the bolt is inserted in the groove of steering gear assembly, tighten the bolt to the specified torque.
- For intermediate shaft mounting bolt direction, refer to [ST-14, "Exploded View"](#). (Do not insert it from the other side.)

### CAUTION:

Never reuse intermediate shaft mounting bolt.

- When connecting intermediate shaft upper side (1) and column shaft, make sure the bolt is securely seated in groove (A) of column shaft before final tightening.
- After installing steering column assembly, perform self-diagnosis with CONSULT to ensure correct operation. Refer to [STC-9, "CONSULT Function"](#).
- Perform inspection after installation. Refer to [ST-15, "Inspection"](#).

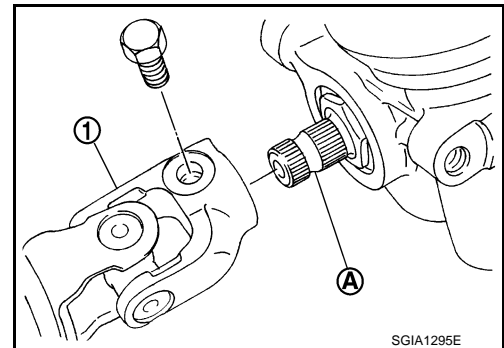
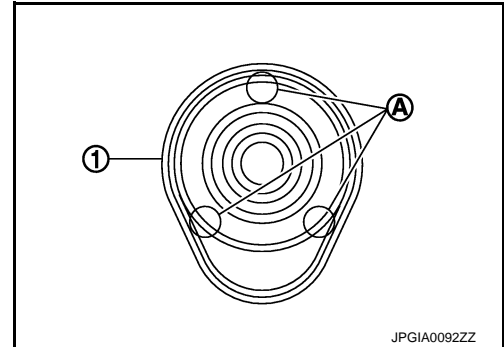

INFOID:000000009752431

## Inspection

### INSPECTION AFTER REMOVAL

- Check each part of intermediate shaft for damage or other malfunctions. Replace if there are any abnormal conditions.

### INSPECTION AFTER INSTALLATION

- Check each part of intermediate shaft for damage or other malfunctions. Replace if there are any abnormal conditions.
- Rotate steering wheel to check for decentered condition, binding, noise, or excessive steering effort.
- Check the steering wheel play, neutral position steering wheel, steering wheel turning force, and front wheel turning angle. Refer to [ST-8, "Inspection"](#), [ST-5, "Inspection"](#).
- Adjust neutral position of steering angle sensor. Refer to [BRC-62, "Work Procedure"](#).

# STEERING GEAR AND LINKAGE

< REMOVAL AND INSTALLATION >

## STEERING GEAR AND LINKAGE

Exploded View

INFOID:00000009752432

### REMOVAL

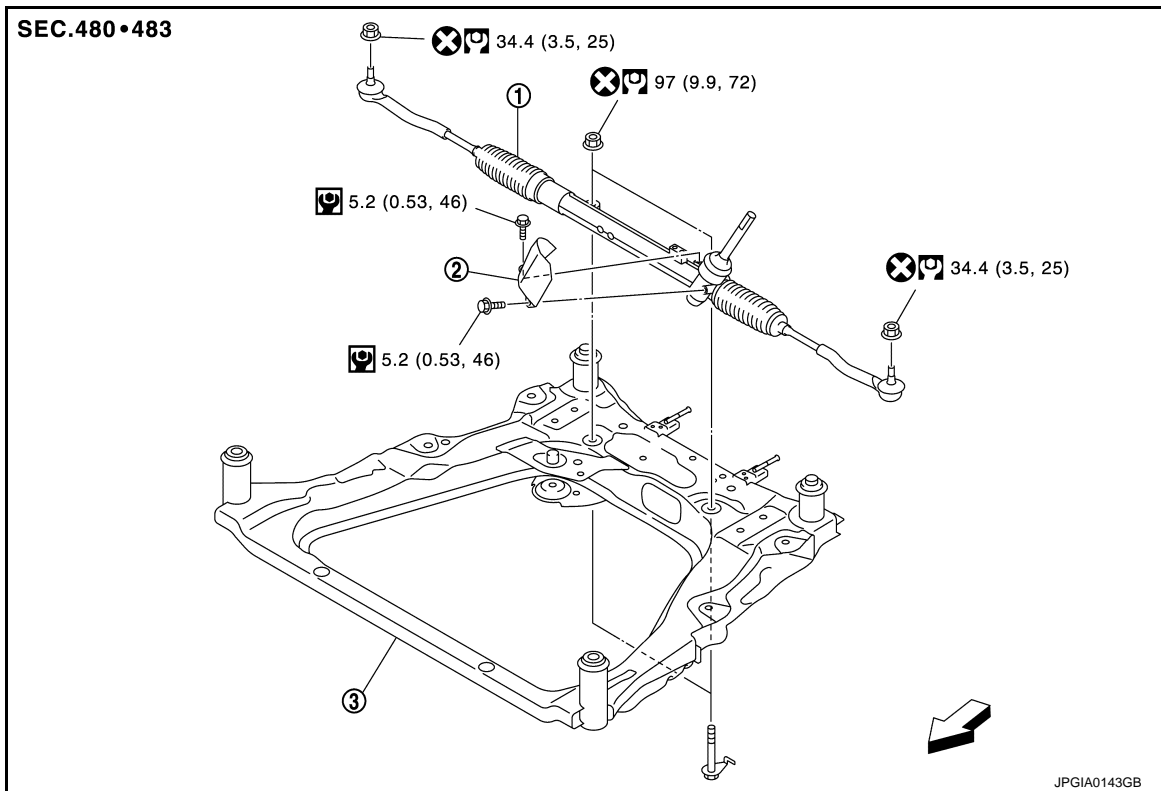

1. Steering gear assembly

2. Heat insulator\*

3. Front suspension member

←: Vehicle front

⊗: Always replace after every disassembly.

⊞: N·m (kg·m, ft·lb)

⊞: N·m (kg·m, in·lb)

\*: The placement of this part depends on production timing. Reinstallation is not required after removal.

### DISASSEMBLY



# STEERING GEAR AND LINKAGE

## < REMOVAL AND INSTALLATION >

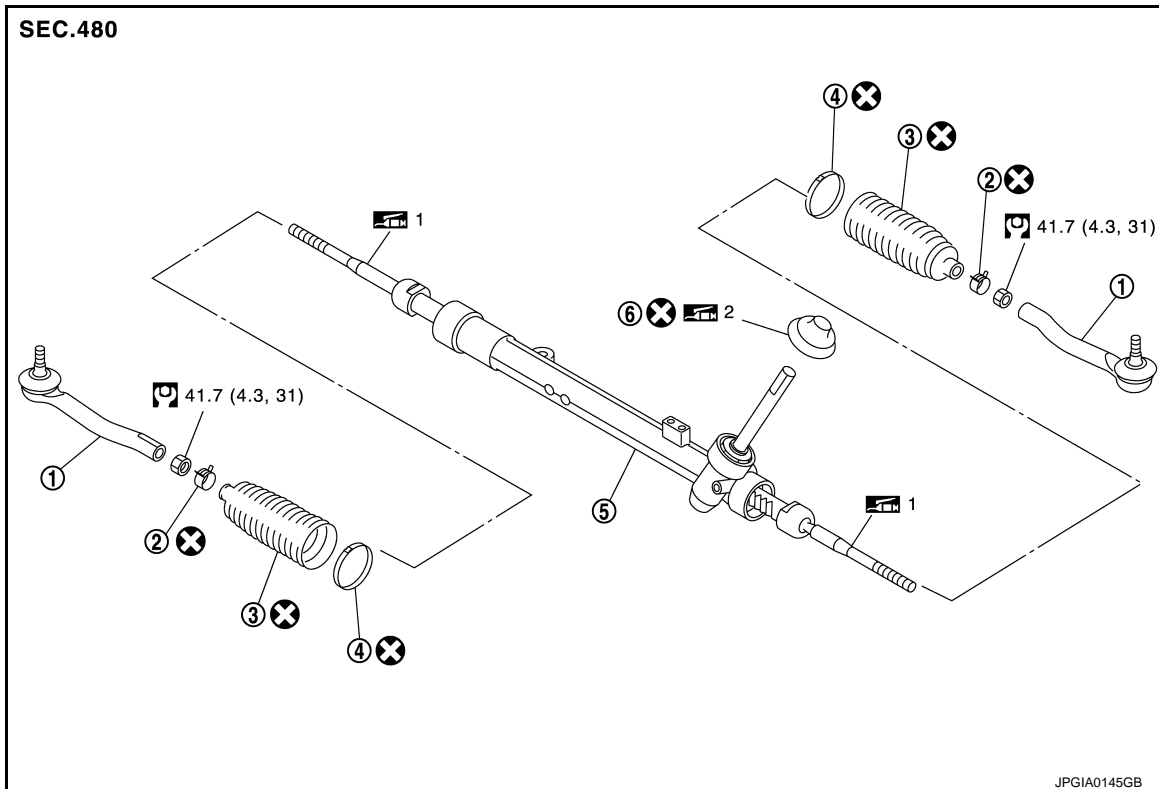

- |                                |                                |               |
|--------------------------------|--------------------------------|---------------|
| 1. Outer socket                | 2. Boot clamp (small diameter) | 3. Boot       |
| 4. Boot clamp (large diameter) | 5. Gear housing assembly       | 6. Dust cover |

1: Apply Genuine Lithium Soap, Autorex A (manufactured by Kyodo yushi) or equivalent.

2: Apply Genuine Lithium Soap, Wanlouver No.2 (manufactured by Kyodo yushi) or equivalent.

: Always replace after every disassembly.

: N·m (kg-m, ft-lb)

## Removal and Installation

INFOID:000000009752433

### REMOVAL

1. Set vehicle to the straight-ahead position.
2. Remove intermediate shaft mounting bolt (steering gear assembly side). Refer to [ST-11, "Removal and Installation"](#).  
**CAUTION:**
  - Spiral cable may be cut if steering wheel turns while separating steering column assembly and steering gear assembly. Always fix the steering wheel using string to avoid turning.
  - Place a matching mark on both intermediate shaft and steering gear assembly before removing intermediate shaft.
  - When removing intermediate shaft, never insert a tool, such as a screwdriver, into the yoke groove to pull out the intermediate shaft. In case of the violation of the above, replace intermediate shaft with a new one.
3. Remove dash seal from vehicle. Refer to [ST-14, "Removal and Installation"](#).
4. Remove tires with power tool. Refer to [WT-46, "Removal and Installation"](#).

# STEERING GEAR AND LINKAGE

## < REMOVAL AND INSTALLATION >

5. Remove steering outer socket from steering knuckle so as not to damage ball joint boot using suitable ball joint remover (commercial service tool).

**CAUTION:**

**Temporarily tighten the nut to prevent damage to threads and to prevent the ball joint remover from sudden drop turning.**

6. Remove front suspension member. Refer to [FSU-17, "Removal and Installation"](#).
7. Remove steering gear assembly.

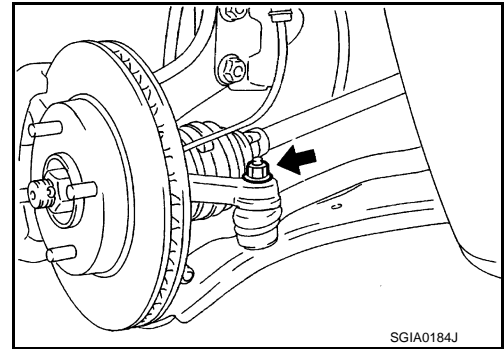

SGIA0184J

## INSTALLATION

Note the following, and install in the reverse order of removal.

**CAUTION:**

**Spiral cable may be cut if steering wheel turns while separating steering column assembly and steering gear assembly. Always fix the steering wheel using string to avoid turning.**

- Perform final tightening of nuts and bolts on each part under unladen conditions with tires on level ground when removing steering gear assembly. Check wheel alignment. Refer to [FSU-7, "Inspection"](#).
- Rotate steering wheel to check for decentered condition, binding, noise or excessive steering effort.
- Never reuse steering outer socket mounting nut and steering gear assembly mounting nut.
- Perform inspection after installation. Refer to [ST-19, "Inspection"](#).

## Disassembly and Assembly

INFOID:000000009752434

### DISASSEMBLY

1. Loosen outer socket lock nut, and remove outer socket.

**CAUTION:**

**When loosening lock nut, be sure to fix outer socket with a wrench or an equivalent.**

2. Remove boot clamps, and then remove boot from inner socket.

**CAUTION:**

**Never damage inner socket part and gear housing part of steering gear assembly when removing boot. steering gear assembly must be replaced if steering gear assembly are damaged because it may cause foreign material interfusion.**

3. Remove dust cover.
4. Perform inspection after disassembly. Refer to [ST-19, "Inspection"](#).

### ASSEMBLY

1. Apply recommended grease to the entire inner perimeter (A) of the dust cover lip and contact surface (B) of the gear housing part, and install dust cover to steering gear assembly.

**Use Genuine Lithium Soap, Wanlouver No.2 (manufactured by Kyodo yushi) or equivalent.**

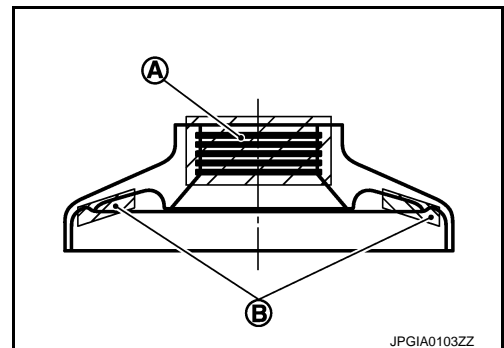

JPGIA0103ZZ

# STEERING GEAR AND LINKAGE

## < REMOVAL AND INSTALLATION >

- Apply recommended grease to inner socket (A) of gear housing assembly and install boot to gear housing assembly.  
**Use Genuine Lithium Soap, Autorex A (manufactured by Kyodo yushi) or equivalent.**

**CAUTION:**

**Never reuse boot.**

Grease application position (Reference)

A : 10 mm (0.39 in)

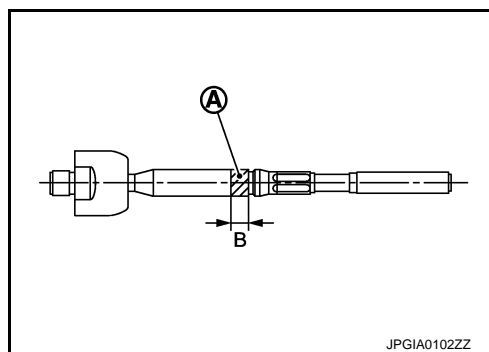

- Install boot clamp (large diameter) (1) to boot using boot band crimping tool (A) [SST: KV40107300 ( — )].

**CAUTION:**

- **Never reuse boot clamp (large diameter).**
- **Install boot clamp (large diameter) (1) securely to boot groove, and crimp it so as to have clearance (B) of 3 mm (0.12 in) or less as shown.**

- Install boot clamp (small diameter) to boot.

**CAUTION:**

**Never reuse boot clamp (small diameter).**

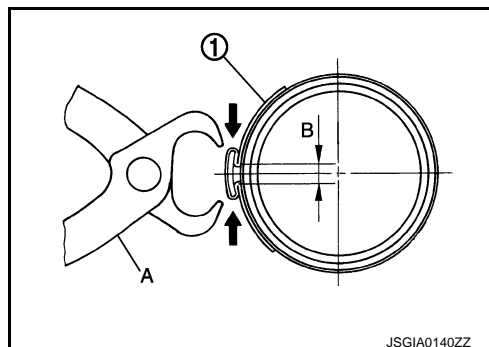

- Adjust inner socket to standard length (L), and then tighten lock nut (1) to the specified torque. Check length again after tightening lock nut.

**Inner socket length (L)**

**: Refer to [ST-21, "Steering Gear and Linkage"](#).**

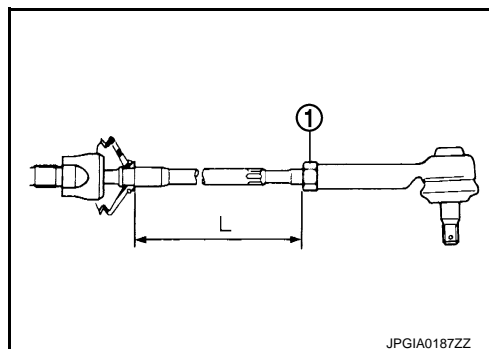

**CAUTION:**

- **When tightening the lock nut (1), be sure to fix outer socket (2) with a wrench or an equivalent to prevent the ball joint from getting contact with the knuckle.**
- **Adjust toe-in after this procedure. The length achieved after toe-in adjustment is not necessary the above value.**

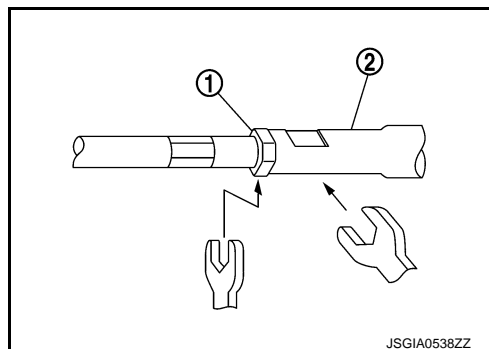

INFOID:000000009752435

## Inspection

### INSPECTION AFTER DISASSEMBLY

#### Boot

- Check boot for cracks, and replace it if a malfunction is detected.

#### Gear housing assembly

- Check gear housing assembly for damage and scratches. Replace if there are any abnormal conditions.

#### Outer Socket and Inner Socket

- Check the following items and replace the component if it does not meet the standard.

# STEERING GEAR AND LINKAGE

## < REMOVAL AND INSTALLATION >

### BALL JOINT SWINGING FORCE

- Hook a spring balance at the point shown in the figure and pull the spring balance. Make sure that the spring balance reads the specified value when ball stud and inner socket start to move. Replace outer socket or steering gear assembly (inner socket) if they are outside the standard.

#### Outer socket

(Measuring point of outer socket: Ball stud upper side)

: Refer to [ST-21, "Steering Gear and Linkage"](#).

#### Inner socket

(Measuring point of inner socket: "\*" mark shown in the figure)

: Refer to [ST-21, "Steering Gear and Linkage"](#).

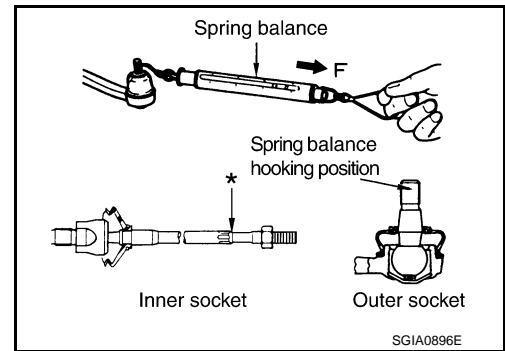

### BALL JOINT AXIAL END PLAY

- Apply an axial load of 490 N (50 kg, 110 lb) to ball stud. Using a dial gauge, measure amount of stud movement, and then make sure that the value is within the following specified range. Replace outer socket (1) steering gear assembly (inner socket) (2) if the measured value is outside the standard.

Outer socket : Refer to [ST-21, "Steering Gear and Linkage"](#).

Inner socket : Refer to [ST-21, "Steering Gear and Linkage"](#).

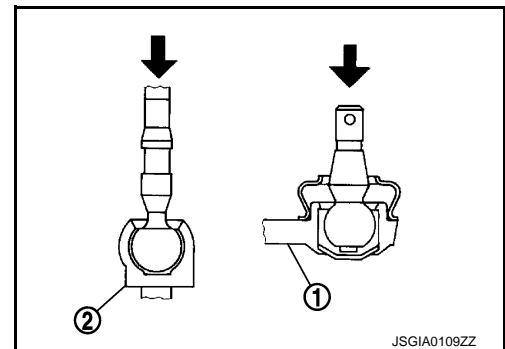

### INSPECTION AFTER INSTALLATION

- Check if steering wheel turns smoothly when it is turned several times fully to the end of the left and right.
- Check the steering wheel play, neutral position steering wheel, steering wheel turning force, and front wheel turning angle. Refer to [ST-8, "Inspection"](#).
- Adjust neutral position of steering angle sensor. Refer to [BRC-62, "Work Procedure"](#).

# SERVICE DATA AND SPECIFICATIONS (SDS)

< SERVICE DATA AND SPECIFICATIONS (SDS)

## SERVICE DATA AND SPECIFICATIONS (SDS)

### SERVICE DATA AND SPECIFICATIONS (SDS)

#### General Specifications

INFOID:000000009752436

Steering gear model	R25N
---------------------	------

#### Steering Wheel

INFOID:000000009752437

Item	Standard
Steering wheel axial end play	0 mm (0 in)
Steering wheel play on the outer circumference	0 - 35 mm (0 - 1.38 in)
Steering wheel turning force	36 N (3.7 kg-f, 8.09 lb-f) or less

#### Steering Angle

INFOID:000000009752438

Unit: Degree minute (Decimal degree)

Item		Standard
Inner wheel	Minimum	33° 00' (33.0°)
	Nominal	36° 00' (36.0°)
	Maximum	37° 00' (37.0°)
Outer wheel	Nominal	31° 00' (31.0°)

#### Steering Column

INFOID:000000009752439

Tilt operating range*	40.0 mm (1.575 in)
Rotating torque	0 – 2.1 N·m (0 – 0.21 kg·m, 0 – 2 in·lb)
Steering column length*	438.5 – 440.5 mm (17.26 – 17.34 in)

\*: For measuring position, refer to [ST-12. "Inspection"](#).

#### Steering Gear and Linkage

INFOID:000000009752440

Item		Standard
Rack stroke neutral position		68 mm (2.68 in)
Inner socket length		83.5 mm (3.287 in)
Outer socket ball joint	Spring balance measurement*	6.0 – 58 N (0.61 – 5.9 kg-f, 1.35 – 13.03 lb-f)
	Axial end play	0.5 mm (0.020 in) or less
Inner socket ball joint	Spring balance measurement*	4.3 – 43.1 N (0.44 – 4.39 kg-f, 0.97 – 9.68 lb-f)
	Axial end play	0.2 mm (0.008 in) or less

\*: For measuring position, refer to [ST-19. "Inspection"](#).