

A  
B  
C

# TM

## SECTION

# TRANSAXLE & TRANSMISSION



### CONTENTS

<b>6MT: RS6F94R</b>		E
<b>PRECAUTION</b> .....	7	F
<b>PRECAUTIONS</b> .....	7	G
Caution for Supplemental Restraint System (SRS) "AIR BAG" and "SEAT BELT PRE-TENSIONER" .....	7	H
Caution for Procedure without Cowl Top Cover.....	7	
Service Notice or Precautions for Manual Transaxle .....	7	I
Precautions for Removing of Battery Terminal .....	8	
<b>PREPARATION</b> .....	9	
<b>PREPARATION</b> .....	9	J
Special Service Tools .....	9	
Commercial Service Tools .....	11	
<b>SYSTEM DESCRIPTION</b> .....	13	
<b>COMPONENT PARTS</b> .....	13	L
Component Parts Location .....	13	
<b>STRUCTURE AND OPERATION</b> .....	14	M
Sectional View .....	14	
System Description .....	14	
<b>DTC/CIRCUIT DIAGNOSIS</b> .....	16	
<b>POSITION SWITCH</b> .....	16	
<b>BACK-UP LAMP SWITCH</b> .....	16	N
BACK-UP LAMP SWITCH : Component Inspection .....	16	
<b>PARK/NEUTRAL POSITION (PNP) SWITCH</b> .....	16	O
PARK/NEUTRAL POSITION (PNP) SWITCH : Component Inspection .....	16	
<b>SYMPTOM DIAGNOSIS</b> .....	17	P
<b>NOISE, VIBRATION AND HARSHNESS (NVH) TROUBLESHOOTING</b> .....	17	
NVH Troubleshooting Chart .....	17	
<b>PERIODIC MAINTENANCE</b> .....	18	
<b>GEAR OIL</b> .....	18	
Inspection .....	18	
Draining .....	18	
Refilling .....	18	
<b>REMOVAL AND INSTALLATION</b> .....	19	
<b>SIDE OIL SEAL</b> .....	19	
Removal and Installation .....	19	
Inspection .....	19	
<b>POSITION SWITCH</b> .....	20	K
Removal and Installation .....	20	
Inspection .....	20	
<b>CONTROL LINKAGE</b> .....	21	L
Exploded View .....	21	
Removal and Installation .....	21	
Inspection .....	24	
<b>AIR BREATHER HOSE</b> .....	25	M
Exploded View .....	25	
Removal and Installation .....	25	
<b>UNIT REMOVAL AND INSTALLATION</b> .....	26	N
<b>TRANSAXLE ASSEMBLY</b> .....	26	O
Exploded View .....	26	
Removal and Installation .....	26	
Inspection .....	27	
<b>UNIT DISASSEMBLY AND ASSEMBLY</b> ...	28	P
<b>TRANSAXLE ASSEMBLY</b> .....	28	
Exploded View .....	28	
Disassembly .....	33	
Assembly .....	38	

Inspection .....	44	<b>BACK-UP LAMP SWITCH .....</b>	<b>73</b>
<b>INPUT SHAFT AND GEAR .....</b>	<b>45</b>	BACK-UP LAMP SWITCH : Component Inspection .....	73
Exploded View .....	45	<b>PARK/NEUTRAL POSITION (PNP) SWITCH .....</b>	<b>73</b>
Disassembly .....	45	PARK/NEUTRAL POSITION (PNP) SWITCH : Component Inspection .....	73
Assembly .....	47	<b>SYMPTOM DIAGNOSIS .....</b>	<b>74</b>
Inspection .....	49	<b>NOISE, VIBRATION AND HARSHNESS (NVH) TROUBLESHOOTING .....</b>	<b>74</b>
<b>MAINSHAFT AND GEAR .....</b>	<b>51</b>	NVH Troubleshooting Chart .....	74
Exploded View .....	51	<b>PERIODIC MAINTENANCE .....</b>	<b>75</b>
Disassembly .....	52	<b>GEAR OIL .....</b>	<b>75</b>
Assembly .....	53	Inspection .....	75
Inspection .....	55	Draining .....	75
<b>REVERSE IDLER SHAFT AND GEAR .....</b>	<b>57</b>	Refilling .....	75
Exploded View .....	57	<b>REMOVAL AND INSTALLATION .....</b>	<b>76</b>
Disassembly .....	57	<b>SIDE OIL SEAL .....</b>	<b>76</b>
Assembly .....	58	Removal and Installation .....	76
Inspection .....	58	<b>POSITION SWITCH .....</b>	<b>77</b>
<b>FINAL DRIVE .....</b>	<b>60</b>	Removal and Installation .....	77
Exploded View .....	60	Inspection .....	77
Disassembly .....	60	<b>CONTROL LINKAGE .....</b>	<b>78</b>
Assembly .....	61	Exploded View .....	78
Inspection .....	61	Removal and Installation .....	78
<b>SERVICE DATA AND SPECIFICATIONS (SDS) .....</b>	<b>63</b>	<b>AIR BREATHER HOSE .....</b>	<b>80</b>
<b>SERVICE DATA AND SPECIFICATIONS (SDS) .....</b>	<b>63</b>	Exploded View .....	80
General Specifications .....	63	Removal and Installation .....	80
<b>6MT: RS6F52H</b>		<b>UNIT REMOVAL AND INSTALLATION ....</b>	<b>81</b>
<b>PRECAUTION .....</b>	<b>64</b>	<b>TRANSAXLE ASSEMBLY .....</b>	<b>81</b>
<b>PRECAUTIONS .....</b>	<b>64</b>	Exploded View .....	81
Precaution for Supplemental Restraint System (SRS) "AIR BAG" and "SEAT BELT PRE-TENSIONER" .....	64	Removal and Installation .....	81
Precaution Necessary for Steering Wheel Rotation After Battery Disconnect .....	64	<b>UNIT DISASSEMBLY AND ASSEMBLY ...</b>	<b>83</b>
Precaution for Work .....	65	<b>TRANSAXLE ASSEMBLY .....</b>	<b>83</b>
Service Notice or Precaution .....	65	Exploded View .....	83
Precautions for Removing of Battery Terminal .....	65	Disassembly .....	87
<b>PREPARATION .....</b>	<b>66</b>	Assembly .....	94
<b>PREPARATION .....</b>	<b>66</b>	Adjustment .....	104
Special Service Tool .....	66	<b>INPUT SHAFT AND GEARS .....</b>	<b>112</b>
Commercial Service Tool .....	69	Exploded View .....	112
<b>SYSTEM DESCRIPTION .....</b>	<b>71</b>	Disassembly and Assembly .....	113
<b>STRUCTURE AND OPERATION .....</b>	<b>71</b>	<b>MAINSHAFT AND GEARS .....</b>	<b>120</b>
Sectional View .....	71	Exploded View .....	120
System Description .....	72	Disassembly and Assembly .....	120
<b>DTC/CIRCUIT DIAGNOSIS .....</b>	<b>73</b>	<b>REVERSE IDLER SHAFT AND GEARS .....</b>	<b>129</b>
<b>POSITION SWITCH .....</b>	<b>73</b>	Disassembly and Assembly .....	129

<b>FINAL DRIVE</b> .....	<b>131</b>	CVT CONTROL SYSTEM : Secondary Speed Sensor .....	153	A
Exploded View .....	131	CVT CONTROL SYSTEM : CVT Fluid Temperature Sensor .....	153	B
Disassembly and Assembly .....	131	CVT CONTROL SYSTEM : Secondary Pressure Sensor .....	154	C
<b>SHIFT CONTROL</b> .....	<b>134</b>	CVT CONTROL SYSTEM : Line Pressure Solenoid Valve .....	154	TM
Exploded View .....	134	CVT CONTROL SYSTEM : Secondary Pressure Solenoid Valve .....	154	E
Disassembly and Assembly .....	134	CVT CONTROL SYSTEM : Torque Converter Clutch Solenoid Valve .....	155	F
<b>SERVICE DATA AND SPECIFICATIONS (SDS)</b> .....	<b>138</b>	CVT CONTROL SYSTEM : Lock-up Select Solenoid Valve .....	155	G
<b>SERVICE DATA AND SPECIFICATIONS (SDS)</b> .....	<b>138</b>	CVT CONTROL SYSTEM : Step Motor .....	155	H
General Specification .....	138	CVT CONTROL SYSTEM : Manual Mode Switch .....	155	I
Gear End Play .....	139	CVT CONTROL SYSTEM : CVT Indicator .....	155	J
Baulk Ring Clearance .....	139	CVT CONTROL SYSTEM : Shift Position Indicator .....	156	K
Available Snap Rings .....	139	CVT CONTROL SYSTEM : Manual Mode Indicator .....	156	L
Available C-Rings .....	140	CVT CONTROL SYSTEM : Paddle Shifter .....	156	M
Available Thrust Washer .....	140			N
Available Adjusting Shims .....	141			O
Available Shims .....	142			P
		<b>CVT: RE0F10B</b>		
<b>PRECAUTION</b> .....	<b>144</b>	<b>SHIFT LOCK SYSTEM</b> .....	<b>156</b>	
<b>PRECAUTIONS</b> .....	<b>144</b>	SHIFT LOCK SYSTEM : Component Parts Location .....	157	
Precaution for Supplemental Restraint System (SRS) "AIR BAG" and "SEAT BELT PRE-TENSIONER" .....	144	SHIFT LOCK SYSTEM : Component Description .....	157	
Precaution for Procedure without Cowl Top Cover .....	144	<b>STRUCTURE AND OPERATION</b> .....	<b>158</b>	
Precautions for Removing of Battery Terminal .....	145	<b>TRANSAXLE</b> .....	<b>158</b>	
Precaution for On Board Diagnosis (OBD) System of CVT and Engine .....	145	TRANSAXLE : Cross-Sectional View .....	158	
Precaution for TCM and Transaxle Assembly or Control Valve Replacement .....	145	TRANSAXLE : Main Component Elements .....	159	
Removal and Installation Procedure for CVT Unit Connector .....	145	TRANSAXLE : Belt & Pulley .....	160	
General Precautions .....	146	<b>FLUID COOLER &amp; FLUID WARMER SYSTEM</b> .....	<b>161</b>	
Service Notice or Precaution .....	147	FLUID COOLER & FLUID WARMER SYSTEM : System Description .....	161	
<b>PREPARATION</b> .....	<b>148</b>	<b>MECHANICAL SYSTEM</b> .....	<b>162</b>	
<b>PREPARATION</b> .....	<b>148</b>	MECHANICAL SYSTEM : System Diagram .....	163	
Special Service Tool .....	148	MECHANICAL SYSTEM : System Description .....	163	
Commercial Service Tool .....	148	MECHANICAL SYSTEM : Component Description .....	167	
<b>SYSTEM DESCRIPTION</b> .....	<b>150</b>	<b>SYSTEM</b> .....	<b>169</b>	
<b>COMPONENT PARTS</b> .....	<b>150</b>	<b>CVT CONTROL SYSTEM</b> .....	<b>169</b>	
<b>CVT CONTROL SYSTEM</b> .....	<b>150</b>	CVT CONTROL SYSTEM : System Description .....	169	
CVT CONTROL SYSTEM : Component Parts Location .....	150	CVT CONTROL SYSTEM : System Diagram .....	170	
CVT CONTROL SYSTEM : Component Description .....	151	CVT CONTROL SYSTEM : Fail-Safe .....	170	
CVT CONTROL SYSTEM : TCM .....	152	<b>OIL PRESSURE CONTROL SYSTEM</b> .....	<b>172</b>	
CVT CONTROL SYSTEM : Transmission Range Switch .....	152	OIL PRESSURE CONTROL SYSTEM : System Diagram .....	173	
CVT CONTROL SYSTEM : Primary Speed Sensor .....	152	OIL PRESSURE CONTROL SYSTEM : System Description .....	173	
		<b>CONTROL SYSTEM</b> .....	<b>174</b>	
		CONTROL SYSTEM : System Diagram .....	174	
		CONTROL SYSTEM : System Description .....	174	
		CONTROL SYSTEM : CAN Communication .....	175	

CONTROL SYSTEM : Engine and CVT Integrated Control (CAN Communication Control) .....	175	Procedure .....	213
CONTROL SYSTEM : Control between CVT and Combination Meter (CAN Communication Control) .....	176	<b>ADDITIONAL SERVICE WHEN REPLACING CONTROL VALVE OR TRANSAXLE ASSEMBLY</b> .....	<b>214</b>
CONTROL SYSTEM : Control between CVT and BCM (CAN Communication Control) .....	176	Description .....	214
<b>LOCK-UP AND SELECT CONTROL SYSTEM</b> .....	<b>176</b>	Procedure .....	214
LOCK-UP AND SELECT CONTROL SYSTEM : System Diagram .....	176	<b>CVT FLUID COOLER SYSTEM</b> .....	<b>216</b>
LOCK-UP AND SELECT CONTROL SYSTEM : System Description .....	176	Cleaning .....	216
<b>SHIFT CONTROL SYSTEM</b> .....	<b>177</b>	<b>STALL TEST</b> .....	<b>219</b>
SHIFT CONTROL SYSTEM : System Diagram ..	177	Inspection and Judgment .....	219
SHIFT CONTROL SYSTEM : System Description ..	177	<b>LINE PRESSURE TEST</b> .....	<b>221</b>
<b>INTEGRATED CONTROL SYSTEM</b> .....	<b>180</b>	Inspection and Judgment .....	221
INTEGRATED CONTROL SYSTEM : System Diagram .....	180	<b>ROAD TEST</b> .....	<b>223</b>
INTEGRATED CONTROL SYSTEM : System Description .....	181	Description .....	223
<b>SHIFT LOCK SYSTEM</b> .....	<b>181</b>	Check before Engine Is Started .....	223
SHIFT LOCK SYSTEM : System Description .....	181	Check at Idle .....	223
<b>KEY LOCK SYSTEM</b> .....	<b>182</b>	Cruise Test .....	224
KEY LOCK SYSTEM : System Description .....	182	<b>CVT POSITION</b> .....	<b>226</b>
<b>ON BOARD DIAGNOSTIC (OBD) SYSTEM</b> ..	<b>183</b>	Inspection and Adjustment .....	226
Diagnosis Description .....	183	<b>DTC/CIRCUIT DIAGNOSIS</b> .....	<b>227</b>
<b>DIAGNOSIS SYSTEM (TCM)</b> .....	<b>185</b>	<b>U0100 LOST COMMUNICATION (ECM A)</b> .....	<b>227</b>
CONSULT Function .....	185	DTC Logic .....	227
ATFTEMP COUNT Conversion Table .....	189	Diagnosis Procedure .....	227
Diagnostic Tool Function .....	189	<b>U1000 CAN COMM CIRCUIT</b> .....	<b>228</b>
<b>ECU DIAGNOSIS INFORMATION</b> .....	<b>190</b>	Description .....	228
<b>TCM</b> .....	<b>190</b>	DTC Logic .....	228
Reference Value .....	190	Diagnosis Procedure .....	228
Fail-Safe .....	195	<b>U1010 CONTROL UNIT (CAN)</b> .....	<b>229</b>
DTC Inspection Priority Chart .....	197	Description .....	229
DTC Index .....	198	DTC Logic .....	229
<b>WIRING DIAGRAM</b> .....	<b>200</b>	Diagnosis Procedure .....	229
<b>CVT CONTROL SYSTEM</b> .....	<b>200</b>	<b>P0703 BRAKE SWITCH B</b> .....	<b>230</b>
Wiring Diagram .....	200	Description .....	230
<b>CVT SHIFT LOCK SYSTEM</b> .....	<b>207</b>	DTC Logic .....	230
Wiring Diagram .....	207	Diagnosis Procedure .....	230
<b>BASIC INSPECTION</b> .....	<b>210</b>	Component Inspection (Stop Lamp Switch) .....	231
<b>DIAGNOSIS AND REPAIR WORKFLOW</b> .....	<b>210</b>	<b>P0705 TRANSMISSION RANGE SENSOR A</b> .....	<b>233</b>
Work Flow .....	210	DTC Logic .....	233
Diagnostic Work Sheet .....	211	Diagnosis Procedure .....	233
<b>ADDITIONAL SERVICE WHEN REPLACING TCM</b> .....	<b>213</b>	Component Inspection (Transmission Range Switch) .....	235
Description .....	213	<b>P0710 TRANSMISSION FLUID TEMPERATURE SENSOR A</b> .....	<b>236</b>
<b>ADDITIONAL SERVICE WHEN REPLACING TCM</b> .....	<b>213</b>	DTC Logic .....	236
Description .....	213	Diagnosis Procedure .....	237
<b>ADDITIONAL SERVICE WHEN REPLACING TCM</b> .....	<b>213</b>	<b>P0715 INPUT SPEED SENSOR A</b> .....	<b>239</b>
Description .....	213	DTC Logic .....	239
		Diagnosis Procedure .....	239

<b>P0720 OUTPUT SPEED SENSOR</b> .....	<b>242</b>	Diagnosis Procedure .....	272	
DTC Logic .....	242			A
Diagnosis Procedure .....	242			
<b>P0725 ENGINE SPEED</b> .....	<b>245</b>	<b>P1705 TP SENSOR</b> .....	<b>275</b>	
Description .....	245	Description .....	275	B
DTC Logic .....	245	DTC Logic .....	275	
Diagnosis Procedure .....	245	Diagnosis Procedure .....	275	
<b>P0740 TORQUE CONVERTER</b> .....	<b>246</b>	<b>P1709 INCOMPLETED DATA WRITING</b> .....	<b>276</b>	C
DTC Logic .....	246	Description .....	276	
Diagnosis Procedure .....	246	DTC Logic .....	276	
<b>P0744 TORQUE CONVERTER</b> .....	<b>249</b>	Diagnosis Procedure .....	276	
Description .....	249	<b>P1722 VEHICLE SPEED</b> .....	<b>278</b>	TM
DTC Logic .....	249	Description .....	278	
Diagnosis Procedure .....	249	DTC Logic .....	278	E
<b>P0745 PRESSURE CONTROL SOLENOID A</b> .....	<b>251</b>	Diagnosis Procedure .....	278	
DTC Logic .....	251	<b>P1723 SPEED SENSOR</b> .....	<b>279</b>	
Diagnosis Procedure .....	251	Description .....	279	F
<b>P0746 PRESSURE CONTROL SOLENOID A</b> .....	<b>253</b>	DTC Logic .....	279	
Description .....	253	Diagnosis Procedure .....	279	
DTC Logic .....	253	<b>P1726 THROTTLE CONTROL SIGNAL</b> .....	<b>281</b>	G
Diagnosis Procedure .....	253	Description .....	281	
<b>P0776 PRESSURE CONTROL SOLENOID B</b> .....	<b>255</b>	DTC Logic .....	281	H
Description .....	255	Diagnosis Procedure .....	281	
DTC Logic .....	255	<b>P1740 SELECT SOLENOID</b> .....	<b>282</b>	
Diagnosis Procedure .....	255	DTC Logic .....	282	I
<b>P0778 PRESSURE CONTROL SOLENOID B</b> .....	<b>257</b>	Diagnosis Procedure .....	282	
DTC Logic .....	257	<b>P1777 STEP MOTOR</b> .....	<b>284</b>	J
Diagnosis Procedure .....	257	DTC Logic .....	284	
<b>P0826 UP AND DOWN SHIFT SW</b> .....	<b>259</b>	Diagnosis Procedure .....	284	
DTC Logic .....	259	<b>P1778 STEP MOTOR</b> .....	<b>287</b>	K
Diagnosis Procedure .....	260	Description .....	287	
Component Inspection (Manual Mode Switch) .....	263	DTC Logic .....	287	
Component Inspection (Paddle Shifter) .....	264	Diagnosis Procedure .....	288	
<b>P0840 TRANSMISSION FLUID PRESSURE</b>		<b>SHIFT POSITION INDICATOR CIRCUIT</b> .....	<b>289</b>	L
<b>SEN/SW A</b> .....	<b>265</b>	Description .....	289	
DTC Logic .....	265	Component Function Check .....	289	M
Diagnosis Procedure .....	265	Diagnosis Procedure .....	289	
<b>P0841 TRANSMISSION FLUID PRESSURE</b>		<b>SHIFT LOCK SYSTEM</b> .....	<b>290</b>	N
<b>SEN/SW A</b> .....	<b>268</b>	Component Function Check .....	290	
Description .....	268	Diagnosis Procedure .....	290	
DTC Logic .....	268	Component Inspection (Shift Lock Solenoid) .....	292	O
Diagnosis Procedure .....	268	Component Inspection (Park Position Switch) .....	292	
<b>P0868 TRANSMISSION FLUID PRESSURE</b> .....	<b>270</b>	Component Inspection (CVT Shift Selector Har-	292	
Description .....	270	ness) .....	292	
DTC Logic .....	270	Component Inspection (Stop Lamp Switch) .....	293	P
Diagnosis Procedure .....	270	<b>SYMPTOM DIAGNOSIS</b> .....	<b>294</b>	
<b>P1701 TCM</b> .....	<b>272</b>	<b>SYSTEM SYMPTOM</b> .....	<b>294</b>	
Description .....	272	Symptom Table .....	294	
DTC Logic .....	272	<b>PERIODIC MAINTENANCE</b> .....	<b>305</b>	
		<b>CVT FLUID</b> .....	<b>305</b>	

Inspection .....	305	2WD : Exploded View .....	332
Changing .....	306	2WD : Removal and Installation .....	332
<b>REMOVAL AND INSTALLATION .....</b>	<b>307</b>	2WD : Inspection .....	333
<b>CVT SHIFT SELECTOR .....</b>	<b>307</b>	<b>AWD .....</b>	<b>333</b>
Exploded View .....	307	AWD : Exploded View .....	333
Removal and Installation .....	307	AWD : Removal and Installation .....	334
Disassembly and Assembly .....	308	AWD : Inspection .....	334
Inspection .....	308	<b>OIL PUMP FITTING BOLT .....</b>	<b>335</b>
<b>CONTROL CABLE .....</b>	<b>310</b>	Description .....	335
Exploded View .....	310	Exploded View .....	335
Removal and Installation .....	311	Removal and Installation .....	335
Inspection .....	313	Inspection .....	335
<b>PADDLE SHIFTER .....</b>	<b>314</b>	<b>WATER HOSE .....</b>	<b>336</b>
Exploded View .....	314	Exploded View .....	336
Removal and Installation .....	314	Removal and Installation .....	336
<b>KEY INTERLOCK CABLE .....</b>	<b>316</b>	Inspection .....	337
Exploded View .....	316	<b>UNIT REMOVAL AND INSTALLATION ...</b>	<b>339</b>
Removal and Installation .....	316	<b>TRANSAXLE ASSEMBLY .....</b>	<b>339</b>
Inspection .....	317	<b>2WD .....</b>	<b>339</b>
<b>TRANSMISSION RANGE SWITCH .....</b>	<b>318</b>	2WD : Exploded View .....	339
Exploded View .....	318	2WD : Removal and Installation .....	339
Removal and Installation .....	318	2WD : Inspection and Adjustment .....	341
Inspection and Adjustment .....	318	<b>AWD .....</b>	<b>342</b>
<b>TCM .....</b>	<b>320</b>	AWD : Exploded View .....	342
Exploded View .....	320	AWD : Removal and Installation .....	342
Removal and Installation .....	320	AWD : Inspection and Adjustment .....	344
Adjustment .....	320	<b>UNIT DISASSEMBLY AND ASSEMBLY ..</b>	<b>346</b>
<b>AIR BREATHER HOSE .....</b>	<b>321</b>	<b>TORQUE CONVERTER AND CONVERTER</b>	
Removal and Installation .....	321	<b>HOUSING OIL SEAL .....</b>	<b>346</b>
<b>CONTROL VALVE .....</b>	<b>322</b>	Exploded View .....	346
Exploded View .....	322	Disassembly .....	346
Removal and Installation .....	322	Assembly .....	346
Inspection and Adjustment .....	328	Inspection .....	347
<b>PRIMARY SPEED SENSOR .....</b>	<b>329</b>	<b>SERVICE DATA AND SPECIFICATIONS</b>	
Exploded View .....	329	<b>(SDS) .....</b>	<b>348</b>
Removal and Installation .....	329	<b>SERVICE DATA AND SPECIFICATIONS</b>	
Inspection .....	329	<b>(SDS) .....</b>	<b>348</b>
<b>SECONDARY SPEED SENSOR .....</b>	<b>330</b>	General Specification .....	348
Exploded View .....	330	Shift Characteristics .....	348
Removal and Installation .....	330	Stall Speed .....	348
Inspection .....	330	Line Pressure .....	348
<b>DIFFERENTIAL SIDE OIL SEAL .....</b>	<b>332</b>	Torque Converter .....	348
<b>2WD .....</b>	<b>332</b>	Heater Thermostat .....	348

PRECAUTION

PRECAUTIONS

Precaution for Supplemental Restraint System (SRS) "AIR BAG" and "SEAT BELT PRE-TENSIONER"

INFOID:000000009752441

The Supplemental Restraint System such as "AIR BAG" and "SEAT BELT PRE-TENSIONER", used along with a front seat belt, helps to reduce the risk or severity of injury to the driver and front passenger for certain types of collision. This system includes seat belt switch inputs and dual stage front air bag modules. The SRS system uses the seat belt switches to determine the front air bag deployment, and may only deploy one front air bag, depending on the severity of a collision and whether the front occupants are belted or unbelted. Information necessary to service the system safely is included in the "SRS AIR BAG" and "SEAT BELT" of this Service Manual.

**WARNING:**

Always observe the following items for preventing accidental activation.

- To avoid rendering the SRS inoperative, which could increase the risk of personal injury or death in the event of a collision that would result in air bag inflation, all maintenance must be performed by an authorized NISSAN/INFINITI dealer.
- Improper maintenance, including incorrect removal and installation of the SRS, can lead to personal injury caused by unintentional activation of the system. For removal of Spiral Cable and Air Bag Module, see "SRS AIR BAG".
- Never use electrical test equipment on any circuit related to the SRS unless instructed to in this Service Manual. SRS wiring harnesses can be identified by yellow and/or orange harnesses or harness connectors.

PRECAUTIONS WHEN USING POWER TOOLS (AIR OR ELECTRIC) AND HAMMERS

**WARNING:**

Always observe the following items for preventing accidental activation.

- When working near the Air Bag Diagnosis Sensor Unit or other Air Bag System sensors with the ignition ON or engine running, never use air or electric power tools or strike near the sensor(s) with a hammer. Heavy vibration could activate the sensor(s) and deploy the air bag(s), possibly causing serious injury.
- When using air or electric power tools or hammers, always switch the ignition OFF, disconnect the battery, and wait at least 3 minutes before performing any service.

Precaution for Procedure without Cowl Top Cover

INFOID:000000009752442

When performing the procedure after removing cowl top cover, cover the lower end of windshield with urethane, etc to prevent damage to windshield.

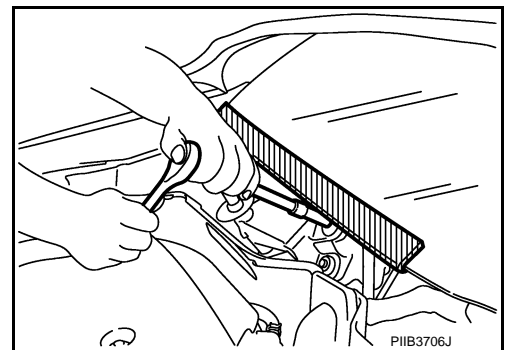

Service Notice or Precautions for Manual Transaxle

INFOID:000000009752443

**CAUTION:**

- Never reuse CSC (Concentric Slave Cylinder). Because CSC slides back to the original position every time when removing transaxle assembly. At this timing, dust on the sliding parts may damage a seal of CSC and may cause clutch fluid leakage. Refer to [CL-17, "Removal and Installation"](#).
- Never reuse transaxle gear oil, once it has been drained.
- Check oil level or replace gear oil with vehicle on level surface.
- During removal or installation, keep inside of transaxle clear of dust or dirt.
- Check for the correct installation status prior to removal or disassembly. If matching marks are required, be certain they never interfere with the function of the parts they are applied.

A  
B  
C  
TM  
E  
F  
G  
H  
I  
J  
K  
L  
M  
N  
O  
P

# PRECAUTIONS

[6MT: RS6F94R]

< PRECAUTION >

- In principle, tighten bolts or nuts gradually in several steps working diagonally from inside to outside. If tightening sequence is specified, use it.
- Never damage sliding surfaces and mating surfaces.

## Precautions for Removing of Battery Terminal

INFOID:000000010176385

- When removing the 12V battery terminal, turn OFF the ignition switch and wait at least 30 seconds.

**NOTE:**

ECU may be active for several tens of seconds after the ignition switch is turned OFF. If the battery terminal is removed before ECU stops, then a DTC detection error or ECU data corruption may occur.

- For vehicles with the 2-batteries, be sure to connect the main battery and the sub battery before turning ON the ignition switch.

**NOTE:**

If the ignition switch is turned ON with any one of the terminals of main battery and sub battery disconnected, then DTC may be detected.

- After installing the 12V battery, always check "Self Diagnosis Result" of all ECUs and erase DTC.

**NOTE:**

The removal of 12V battery may cause a DTC detection error.

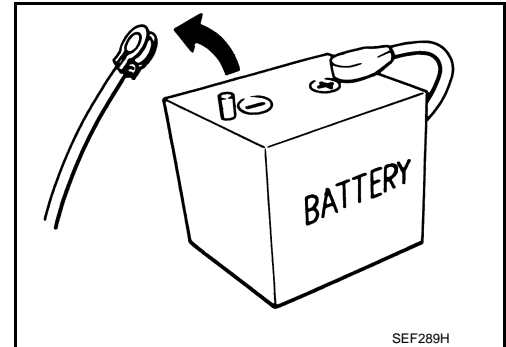



# PREPARATION

< PREPARATION >

[6MT: RS6F94R]

## PREPARATION

### PREPARATION

#### Special Service Tools

INFOID:000000009752444

The actual shapes of Kent-Moore tools may differ from those of special service tools illustrated here.

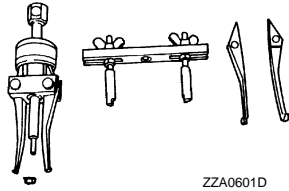
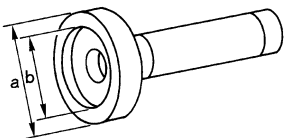
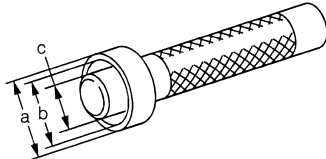
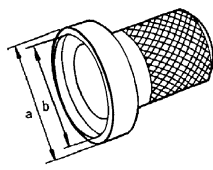
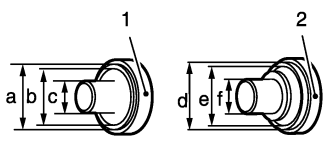
Tool number (Kent-Moore No.) Tool name	Description
KV381054S0 (J-34286) Puller   <p style="text-align: center;">ZZA0601D</p>	Removing mainshaft front bearing outer race
KV38100200 (-) Drift a: 65 mm (2.56 in) dia. b: 49 mm (1.93 in) dia.   <p style="text-align: center;">ZZA1143D</p>	<ul style="list-style-type: none"> <li>• Installing mainshaft front bearing outer race</li> <li>• Installing mainshaft rear bearing outer race</li> <li>• Installing differential side bearing outer race (clutch housing side)</li> </ul>
ST33220000 (-) Drift a: 37 mm (1.46 in) dia. b: 31 mm (1.22 in) dia. c: 22 mm (0.87 in) dia.   <p style="text-align: center;">ZZA1046D</p>	Installing input shaft oil seal
ST33400001 (J-26082) Drift a: 60 mm (2.36 in) dia. b: 47 mm (1.85 in) dia.   <p style="text-align: center;">ZZA0814D</p>	Installing differential side bearing outer race (transaxle case side)
KV32500QAA (-) (Renault SST: B.vi 1666) Drift set 1. — (-) (Stamping number: B.vi 1666-A) Drift a: 54.3 mm (2.138 in) dia. b: 45 mm (1.77 in) dia. c: 26.6 mm (1.047 in) dia. 2. — (-) (Stamping number: B.vi 1666-B) Drift d: 54 mm (2.13 in) dia. e: 48.6 mm (1.913 in) dia. f: 26.6 mm (1.047 in) dia.   <p style="text-align: center;">JPDIC0730ZZ</p>	Installing differential side oil seal

A  
B  
C  
TM  
E  
F  
G  
H  
I  
J  
K  
L  
M  
N  
O  
P

# PREPARATION

< PREPARATION >

[6MT: RS6F94R]

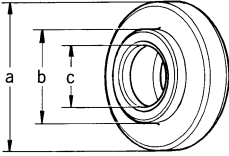
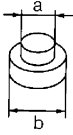
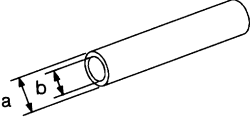
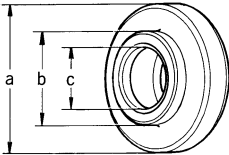
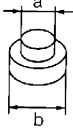
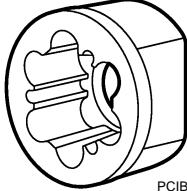
Tool number (Kent-Moore No.) Tool name		Description
ST36720030 (-) Drift a: 70 mm (2.76 in) dia. b: 40 mm (1.57 in) dia. c: 29 mm (1.14 in) dia.	 <p style="text-align: center; font-size: small;">ZZA0978D</p>	<ul style="list-style-type: none"> <li>• Installing input shaft rear bearing</li> <li>• Installing mainshaft front bearing inner race</li> </ul>
ST33052000 (-) Drift a: 22 mm (0.87 in) dia. b: 28 mm (1.10 in) dia.	 <p style="text-align: center; font-size: small;">ZZA0969D</p>	<ul style="list-style-type: none"> <li>• Removing mainshaft rear bearing inner race</li> <li>• Removing 6th main gear</li> <li>• Removing 5th main gear</li> <li>• Removing 4th main gear</li> <li>• Removing 1st main gear</li> <li>• Removing 1st-2nd synchronizer hub assembly</li> <li>• Removing 2nd main gear</li> <li>• Removing bushing</li> <li>• Removing 3rd main gear</li> <li>• Removing mainshaft front bearing inner race</li> </ul>
KV32102700 (-) Drift a: 48.6 mm (1.913 in) dia. b: 41.6 mm (1.638 in) dia.	 <p style="text-align: center; font-size: small;">S-NT065</p>	<ul style="list-style-type: none"> <li>• Installing bushing</li> <li>• Installing 2nd main gear</li> <li>• Installing 3rd main gear</li> <li>• Installing 4th main gear</li> <li>• Installing 5th main gear</li> <li>• Installing 6th main gear</li> </ul>
ST30901000 (J-26010-01) Drift a: 79 mm (3.11 in) dia. b: 45 mm (1.77 in) dia. c: 35.2 mm (1.386 in) dia.	 <p style="text-align: center; font-size: small;">ZZA0978D</p>	Installing mainshaft rear bearing inner race
ST33061000 (J-8107-2) Drift a: 28.5 mm (1.122 in) dia. b: 38 mm (1.50 in) dia.	 <p style="text-align: center; font-size: small;">ZZA0969D</p>	Removing differential side bearing inner race (clutch housing side)
KV32300QAM (-) (Renault SST: B.vi 1823) Drift	 <p style="text-align: center; font-size: small;">PCIB2078J</p>	Removing and installing input shaft rear bearing mounting bolt

# PREPARATION

< PREPARATION >

[6MT: RS6F94R]

## Commercial Service Tools

INFOID:000000009752445

Tool name	Description
Socket a: 8 mm (0.31 in) b: 5 mm (0.20 in)	Removing and installing drain plug
Spacer a: 25 mm (0.98 in) dia. b: 25 mm (0.98 in)	Removing mainshaft front bearing outer race
Drift a: 17 mm (0.67 in) dia.	Installing bushing
Drift a: 24 mm (0.94 in) dia.	Removing input shaft rear bearing
Drift a: 35 mm (1.38 in) dia. b: 25 mm (0.98 in) dia.	Installing input shaft front bearing
Drift a: 43 mm (1.69 in) dia.	<ul style="list-style-type: none"> <li>• Installing input shaft rear bearing</li> <li>• Removing differential side bearing inner race (transaxle case side)</li> </ul>

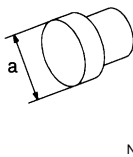
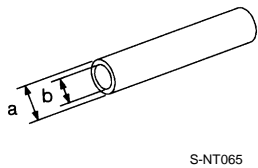
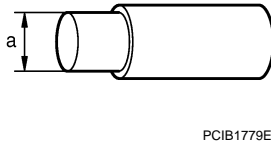
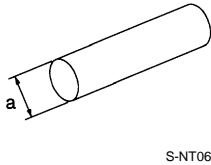
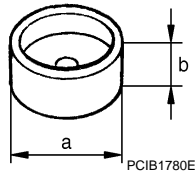
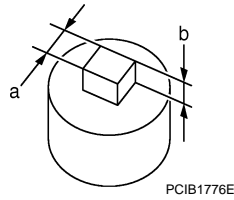



A  
B  
C  
TM  
E  
F  
G  
H  
I  
J  
K  
L  
M  
N  
O  
P

# PREPARATION

< PREPARATION >

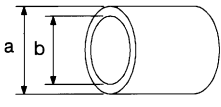
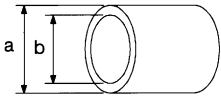
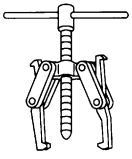
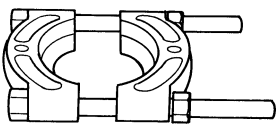
[6MT: RS6F94R]

Tool name	Description
<p>Drift                      a: 45 mm (1.77 in) dia.                      b: 39 mm (1.54 in) dia.</p>  <p style="text-align: center;">S-NT474</p>	<p>Installing differential side bearing inner race (clutch housing side)</p>
<p>Drift                      a: 52 mm (2.05 in) dia.                      b: 45 mm (1.77 in) dia.</p>  <p style="text-align: center;">S-NT474</p>	<p>Installing differential side bearing inner race (transaxle case side)</p>
<p>Puller</p>  <p style="text-align: center;">NT077</p>	<ul style="list-style-type: none"> <li>• Removing differential side bearing inner race (clutch housing side)</li> <li>• Removing differential side bearing inner race (transaxle case side)</li> </ul>
<p>Puller</p>  <p style="text-align: center;">ZZB0823D</p>	<ul style="list-style-type: none"> <li>• Removing differential side bearing inner race (clutch housing side)</li> <li>• Removing differential side bearing inner race (transaxle case side)</li> <li>• Removing input shaft rear bearing</li> <li>• Removing input shaft front bearing</li> <li>• Removing mainshaft rear bearing inner race</li> <li>• Removing 6th main gear</li> <li>• Removing 4th main gear</li> <li>• Removing 5th main gear</li> <li>• Removing 1st main gear</li> <li>• Removing 1st-2nd synchronizer hub assembly</li> <li>• Removing 2nd main gear</li> <li>• Removing 3rd main gear</li> <li>• Removing mainshaft front bearing inner race</li> </ul>
<p>Remover</p>  <p style="text-align: center;">S-NT134</p>	<ul style="list-style-type: none"> <li>• Removing bushing</li> <li>• Removing mainshaft rear bearing outer race</li> </ul>

SYSTEM DESCRIPTION

COMPONENT PARTS

Component Parts Location

POSITION SWITCH

1 : Position switch

INFOID:000000009752446

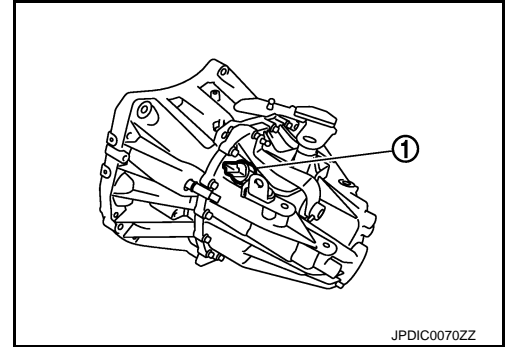

A  
B  
C  
TM  
E  
F  
G  
H  
I  
J  
K  
L  
M  
N  
O  
P

# STRUCTURE AND OPERATION

< SYSTEM DESCRIPTION >

[6MT: RS6F94R]

## STRUCTURE AND OPERATION

### Sectional View

INFOID:000000009752447

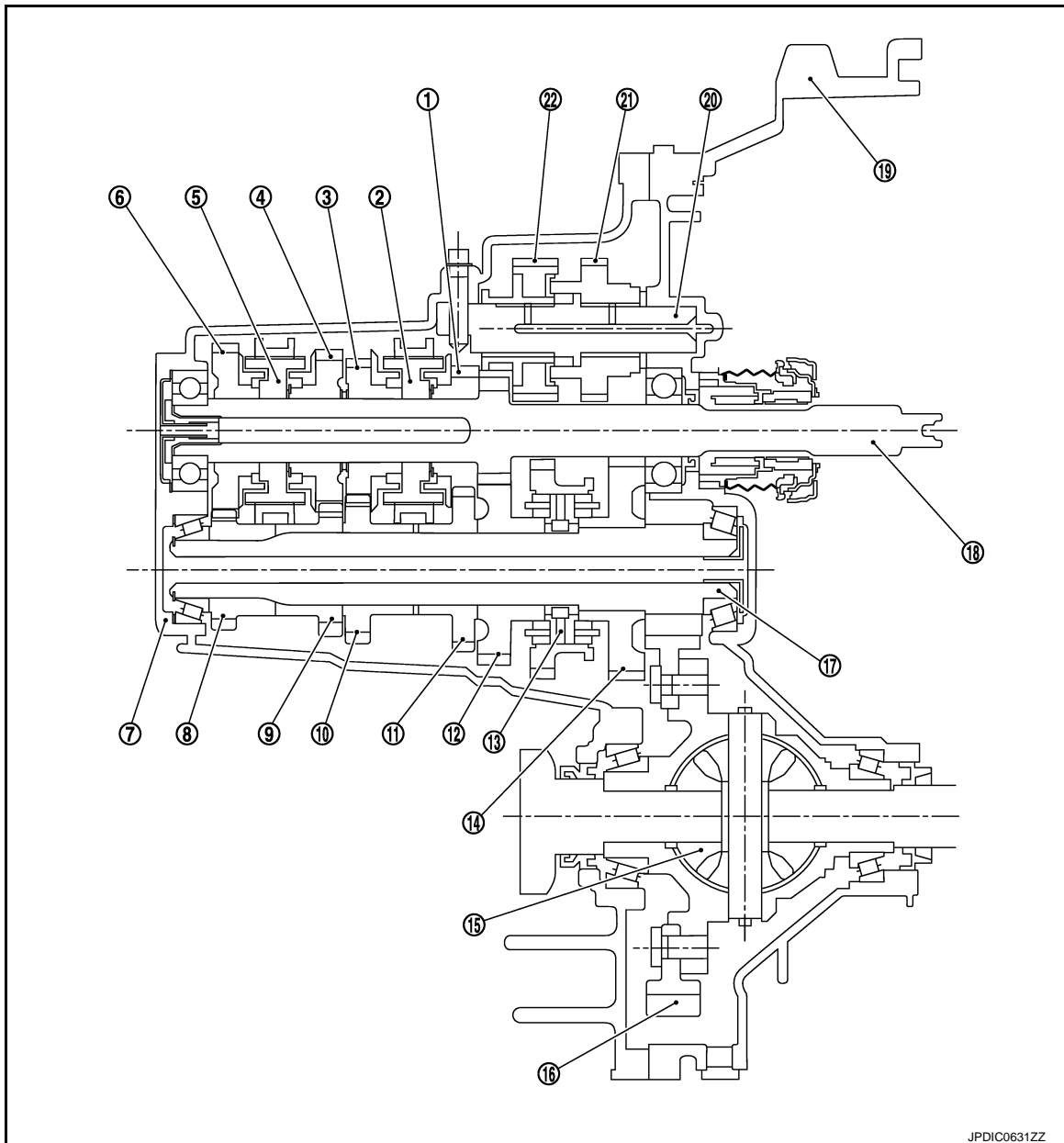

JPDIC0631ZZ

- |                                       |                                      |                        |
|---------------------------------------|--------------------------------------|------------------------|
| 1. 3rd input gear                     | 2. 3rd-4th synchronizer hub assembly | 3. 4th input gear      |
| 4. 5th input gear                     | 5. 5th-6th synchronizer hub assembly | 6. 6th input gear      |
| 7. Transaxle case                     | 8. 6th main gear                     | 9. 5th main gear       |
| 10. 4th main gear                     | 11. 3rd main gear                    | 12. 2nd main gear      |
| 13. 1st-2nd synchronizer hub assembly | 14. 1st main gear                    | 15. Differential       |
| 16. Final gear                        | 17. Mainshaft                        | 18. Input shaft        |
| 19. Clutch housing                    | 20. Reverse idler shaft              | 21. Reverse input gear |
| 22. Reverse output gear               |                                      |                        |

### System Description

INFOID:000000009752448

### TRIPLE-CONE SYNCHRONIZER

# STRUCTURE AND OPERATION

## < SYSTEM DESCRIPTION >

[6MT: RS6F94R]

Triple-cone synchronizers are adopted for the 1st and the 2nd gears to reduce operating force of the shifter lever.

- 1 : 1st main gear
- 2 : 1st-2nd coupling sleeve
- 3 : Insert key
- 4 : Outer baulk ring
- 5 : 2nd main gear
- 6 : Synchronizer cone
- 7 : Inner baulk ring
- 8 : 1st-2nd synchronizer hub

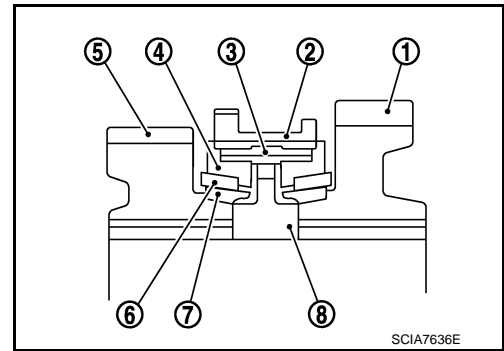

A

B

C

TM

## REVERSE GEAR NOISE PREVENTION FUNCTION (SYNCHRONIZING METHOD)

Reverse gear assembly consists of reverse input gear, return spring, reverse baulk ring, and reverse output gear. When the shifter lever is shifted to the reverse position, the construction allows smooth shift operation by stopping the reverse idler shaft rotation by frictional force of synchronizer.

- 1 : Reverse fork rod
- 2 : Reverse output gear
- 3 : Return spring
- 4 : Reverse baulk ring
- 5 : Reverse input gear

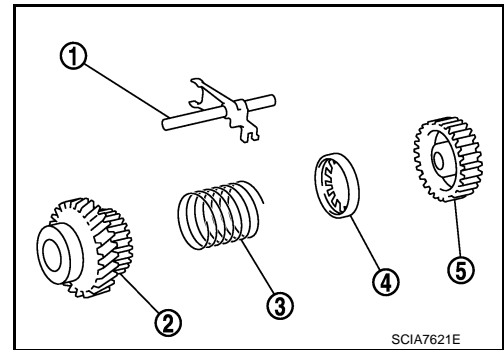

E

F

G

H

I

J

K

L

M

N

O

P

## DTC/CIRCUIT DIAGNOSIS

### POSITION SWITCH

#### BACK-UP LAMP SWITCH

#### BACK-UP LAMP SWITCH : Component Inspection

INFOID:000000009752449

#### 1. CHECK BACK-UP LAMP SWITCH

1. Disconnect position switch connector. Refer to [TM-20, "Removal and Installation"](#).
2. Check continuity between position switch terminals.

Terminals		Condition	Continuity
1	2	Reverse gear position	Existed
		Except reverse gear position	Not existed

Is the inspection result normal?

YES >> INSPECTION END

NO >> Replace position switch. Refer to [TM-20, "Removal and Installation"](#).

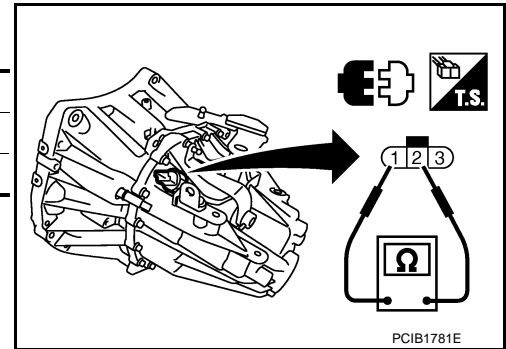

#### PARK/NEUTRAL POSITION (PNP) SWITCH

#### PARK/NEUTRAL POSITION (PNP) SWITCH : Component Inspection

INFOID:000000009752450

#### 1. CHECK PARK/NEUTRAL POSITION (PNP) SWITCH

1. Disconnect position switch connector. Refer to [TM-20, "Removal and Installation"](#).
2. Check continuity between position switch terminals.

Terminals		Condition	Continuity
2	3	Neutral gear position	Existed
		Except neutral gear position	Not existed

Is the inspection result normal?

YES >> INSPECTION END

NO >> Replace position switch. Refer to [TM-20, "Removal and Installation"](#).

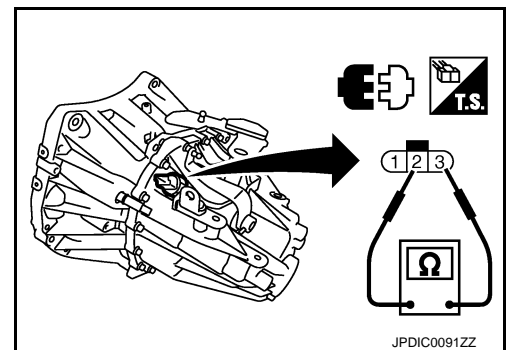



# NOISE, VIBRATION AND HARSHNESS (NVH) TROUBLESHOOTING

< SYMPTOM DIAGNOSIS >

[6MT: RS6F94R]

## SYMPTOM DIAGNOSIS

### NOISE, VIBRATION AND HARSHNESS (NVH) TROUBLESHOOTING

#### NVH Troubleshooting Chart

INFOID:000000009752451

Use the chart below to find the cause of the symptom. The numbers indicate the order of the inspection. If necessary, repair or replace these parts.

SUSPECTED PARTS (Possible cause)		SUSPECTED PARTS											
		OIL (Oil level is low)	OIL (Wrong oil)	OIL (Oil level is high)	GASKET (Damaged)	OIL SEAL (Worn or damaged)	O-RING (Worn or damaged)	SHIFT CONTROL LINKAGE (Worn)	SHIFT FORK (Worn)	GEAR (Worn or damaged)	BEARING (Worn or damaged)	BAULK RING (Worn or damaged)	INSERT SPRING (Damaged)
Reference			TM-18			TM-28		TM-24	TM-28			TM-28	
Symptoms	Noise	1	2							3	3		
	Oil leakage		3	1	2	2	2						
	Hard to shift or will not shift		1	1				2				3	3
	Jumps out of gear							1	2	2			

A  
B  
C  
TM  
E  
F  
G  
H  
I  
J  
K  
L  
M  
N  
O  
P

## PERIODIC MAINTENANCE

### GEAR OIL

#### Inspection

INFOID:000000009752452

#### OIL LEAKAGE

Make sure that gear oil is not leaking from transaxle or around it.

#### OIL LEVEL

1. Remove filler plug (1) and gasket from transaxle case.
2. Check the oil level from filler plug mounting hole as shown in the figure.  
**CAUTION:**  
**Never start engine while checking oil level.**
3. Set a gasket on filler plug and then install it to transaxle case.  
**CAUTION:**  
**Never reuse gasket.**
4. Tighten filler plug to the specified torque. Refer to [TM-28](#), "[Exploded View](#)".

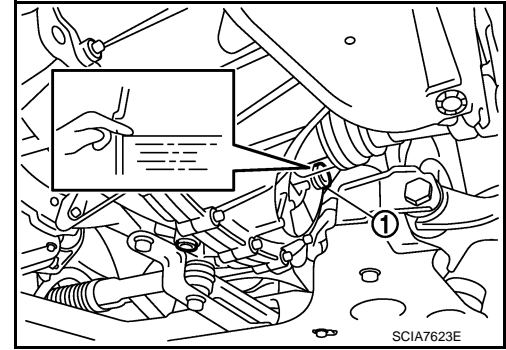

#### Draining

INFOID:000000009752453

1. Start engine and let it run to warm up transaxle.
2. Stop engine. Remove drain plug (1) and gasket, using a socket [Commercial service tool] and then drain gear oil.
3. Set a gasket on drain plug and install it to clutch housing, using a socket [Commercial service tool].  
**CAUTION:**  
**Never reuse gasket.**
4. Tighten drain plug to the specified torque. Refer to [TM-28](#), "[Exploded View](#)".

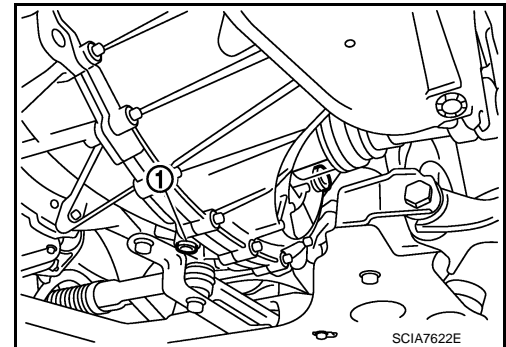

#### Refilling

INFOID:000000009752454

1. Remove filler plug (1) and gasket from transaxle case.
2. Fill with new gear oil until oil level reaches the specified limit at filler plug mounting hole as shown in the figure.

**Oil grade and viscosity** : Refer to [MA-10](#), "[Fluids and Lubricants](#)".

**Oil capacity** : Refer to [TM-63](#), "[General Specifications](#)".

3. After refilling gear oil, check the oil level. Refer to [TM-18](#), "[Inspection](#)".
4. Set a gasket on filler plug and then install it to transaxle case.  
**CAUTION:**  
**Never reuse gasket.**
5. Tighten filler plug to the specified torque. Refer to [TM-28](#), "[Exploded View](#)".

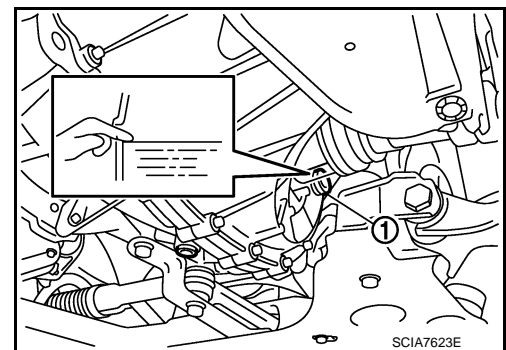

# SIDE OIL SEAL

< REMOVAL AND INSTALLATION >

[6MT: RS6F94R]

## REMOVAL AND INSTALLATION

### SIDE OIL SEAL

#### Removal and Installation

INFOID:000000009752455

#### REMOVAL

1. Remove front drive shafts. Refer to [FAX-20. "LEFT SIDE : Removal and Installation"](#) (LEFT SIDE) and [FAX-22. "RIGHT SIDE : Removal and Installation"](#) (RIGHT SIDE).
2. Remove differential side oil seals (1) from clutch housing and transaxle case, using an oil seal remover.

**CAUTION:**

**Never damage transaxle case and clutch housing.**

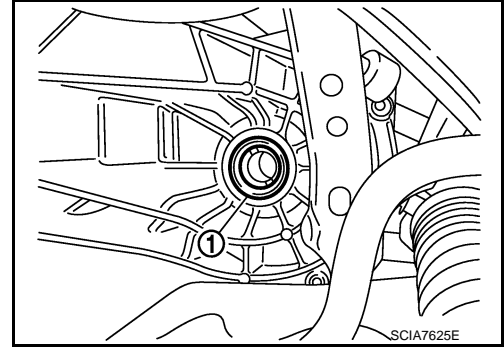

#### INSTALLATION

Note the following, and install in the reverse order of removal.

- Install differential side oil seals (1) to clutch housing and transaxle case, using the drift [Stamping number: B.vi 1666-B] of the drift set [SST: KV32500QAA ( - )].

A : Transaxle case side

B : Clutch housing side

**Dimension "L1" : 1.2 – 1.8 mm (0.047 – 0.071 in)**

**Dimension "L2" : 2.7 – 3.3 mm (0.106 – 0.130 in)**

**CAUTION:**

- **Never incline differential side oil seal.**
- **Never damage clutch housing and transaxle case.**

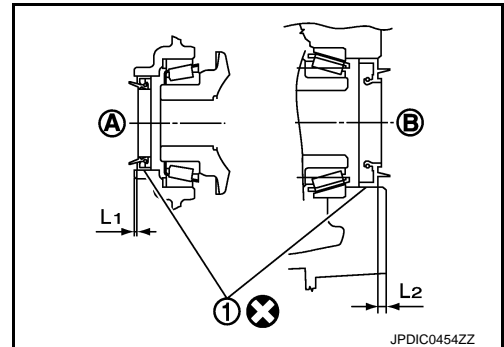

#### Inspection

INFOID:000000009752456

#### INSPECTION AFTER INSTALLATION

Check the oil level and oil leakage. Refer to [TM-18. "Inspection"](#).

# POSITION SWITCH

< REMOVAL AND INSTALLATION >

[6MT: RS6F94R]

## POSITION SWITCH

### Removal and Installation

INFOID:000000009752457

#### REMOVAL

1. Remove battery. Refer to [PG-99, "Removal and Installation"](#).
2. Disconnect position switch connector.
3. Remove position switch from transaxle case.

#### INSTALLATION

1. Apply recommended sealant to threads of position switch.
  - Use Genuine Silicone RTV or an equivalent. Refer to [GI-24, "Recommended Chemical Products and Sealants"](#).

**CAUTION:**

**Remove old sealant and oil adhering to threads.**

2. Install position switch to transaxle case.
3. Tighten position switch to the specified torque. Refer to [TM-28, "Exploded View"](#).
4. For the next step and after, install in the reverse order of removal.

#### Inspection

INFOID:000000009752458

#### INSPECTION AFTER INSTALLATION

- Check continuity between position switch terminals. Refer to [TM-16, "BACK-UP LAMP SWITCH : Component Inspection"](#) (Back-up lamp switch) and [TM-16, "PARK/NEUTRAL POSITION \(PNP\) SWITCH : Component Inspection"](#) (PNP switch).
- Check the oil leakage. Refer to [TM-18, "Inspection"](#).

# CONTROL LINKAGE

< REMOVAL AND INSTALLATION >

[6MT: RS6F94R]

## CONTROL LINKAGE

Exploded View

INFOID:000000009752459

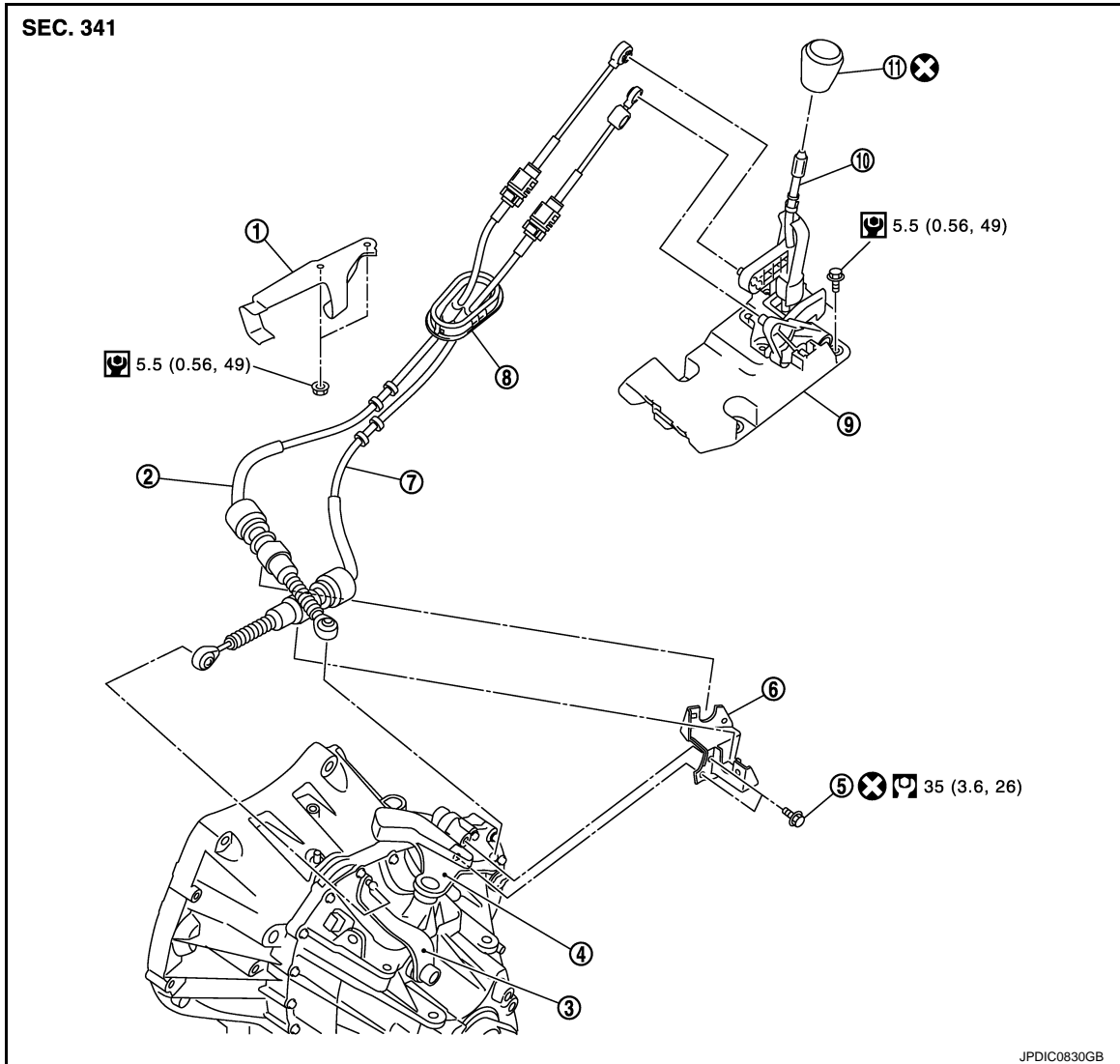

- |                    |                        |                                |
|--------------------|------------------------|--------------------------------|
| 1. Bracket         | 2. Shifter cable       | 3. Selector lever              |
| 4. Shifter lever A | 5. Tapping bolt        | 6. Cable mounting bracket      |
| 7. Selector cable  | 8. Grommet             | 9. M/T shift selector assembly |
| 10. Shifter lever  | 11. Shifter lever knob |                                |

: Always replace after every disassembly.

: N-m (kg-m, ft-lb)

: N-m (kg-m, in-lb)

## Removal and Installation

INFOID:000000009752460

### REMOVAL

1. Shift the shifter lever to the neutral position.
2. Remove air cleaner case. Refer to [EM-25, "Removal and Installation"](#).

# CONTROL LINKAGE

## < REMOVAL AND INSTALLATION >

[6MT: RS6F94R]

3. Remove bracket (1), as per the following procedure.

← : Vehicle front

- a. Disconnect clips (A) from bracket.
- b. Remove bolts (B) from bracket.
- c. Remove bracket.
4. Pull out and disconnect the each cable from the shifter lever A and the selector lever, using a suitable remover.

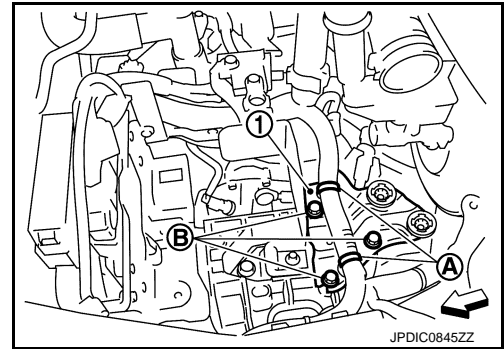

5. While pressing the lock of the selector cable in the direction of the arrow shown in the figure, remove the selector cable from the cable mounting bracket.
6. While pressing the lock of the shifter cable in the direction of the arrow shown in the figure, remove the shifter cable from the cable mounting bracket.
7. Remove cable mounting bracket from transaxle case.
8. Pull the shifter lever knob upward to remove.
9. Remove center console assembly. Refer to [JP-24, "Removal and Installation"](#).
10. Pull out and disconnect the shifter cable from the pin of the M/T shift selector assembly, using a suitable remover.
11. Pull up the stopper (A) of the selector cable in the direction of the arrow as shown in the figure.
12. Pull out and disconnect the selector cable from the pin of the M/T shift selector assembly, using a suitable remover.

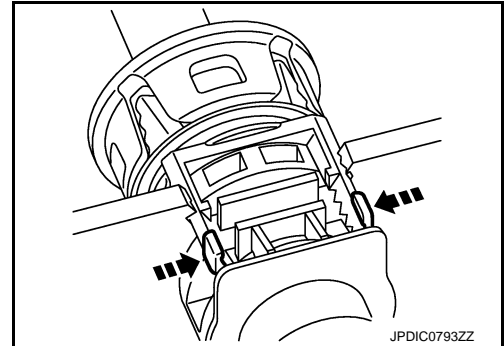

13. While pressing the lock of the selector cable in the direction of the arrow shown in the figure, remove the selector cable from the M/T shift selector assembly.
14. While pressing the lock of the shifter cable in the direction of the arrow shown in the figure, remove the shifter cable from the M/T shift selector assembly.
15. Remove the M/T shift selector assembly.
16. Remove three way catalyst and heat plate. Refer to [EX-8, "Removal and Installation"](#).
17. Remove the bracket from the vehicle.

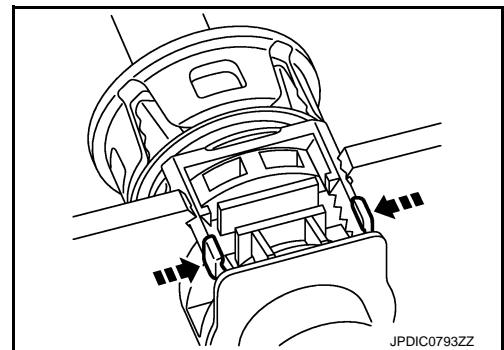
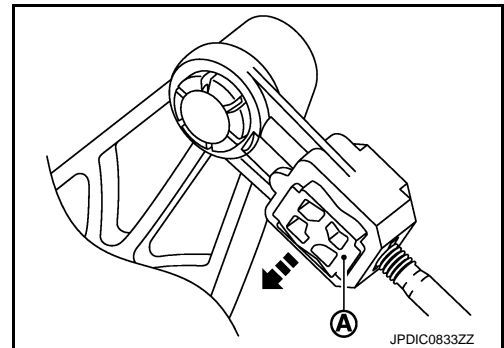

# CONTROL LINKAGE

## < REMOVAL AND INSTALLATION >

[6MT: RS6F94R]

18. Disengage the pawls (A) of the grommet (1), and pull downwards to remove.
19. Remove the shifter cable and selector cable from the vehicle.

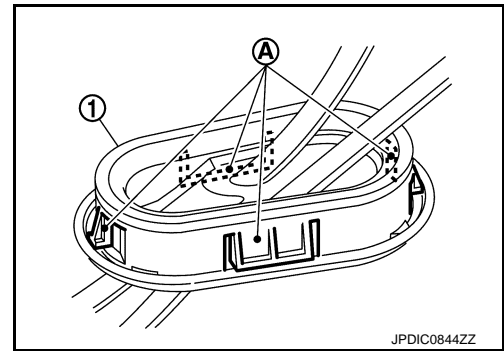

## INSTALLATION

Note the following, and install in the reverse order of removal.

### CAUTION:

- Install each cable without causing interference with other parts, a 120 mm (4.72 in)-or-less bend, and a 180-degrees-or-more twist.
- Install boot of each cable without causing interference with other parts and a 90-degrees-or-more twist.
- Fit boot of to center console assembly the groove on shifter lever knob.
- To install the shifter lever knob, press it into the shifter lever.

### CAUTION:

- Never reuse shifter lever knob.
- Be careful with orientation of shifter lever knob.
- Tapping work for tapping bolts is not applied to new transaxle case. Do not perform tapping by other than screwing tapping bolts because tapping is formed by screwing tapping bolts into transaxle case.

### CAUTION:

#### Never reuse tapping bolt.

- Insert the each cable until it reaches the cable mounting bracket and M/T shift selector assembly.
- Insert the each cable until it reaches the shifter lever A and the selector lever.
- Shift the shifter lever to the neutral position.
- Install the shifter cable (1) and the selector cable (2) to the bracket (3) as shown in the figure.

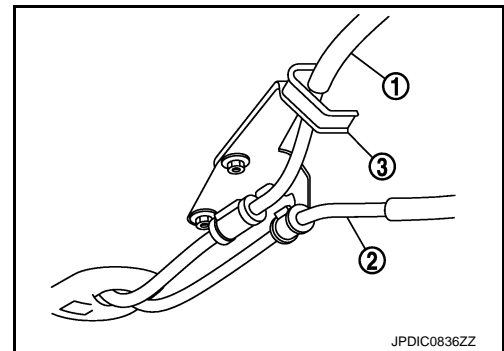

Install the selector cable (the M/T shift selector assembly side), as per the following procedure.

When M/T shift selector assembly is replaced:

1. Install the selector cable to the M/T shift selector assembly.
2. Shift the shifter lever to the neutral position.
3. Install the lever stopper (A) to the M/T shift selector assembly as shown in the figure.

### CAUTION:

**Selector cable cannot be adjusted accurately without using the lever stopper.**

4. Check that the shifter lever does not move in the direction of the select. If it moves, repeat step 3.

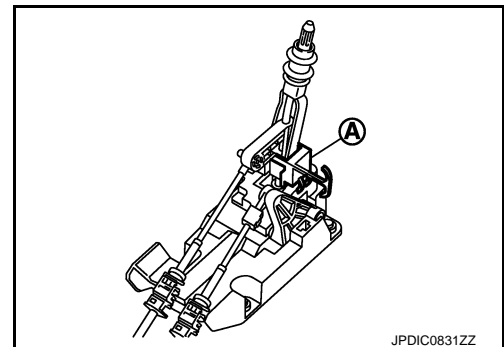

# CONTROL LINKAGE

## < REMOVAL AND INSTALLATION >

[6MT: RS6F94R]

5. Insert the stopper (A) until it reaches the selector cable.
6. Remove the lever stopper from the M/T shift selector assembly.
7. Shift the shifter lever to each gear position to check that there are no bindings. If any, repeat step 3.

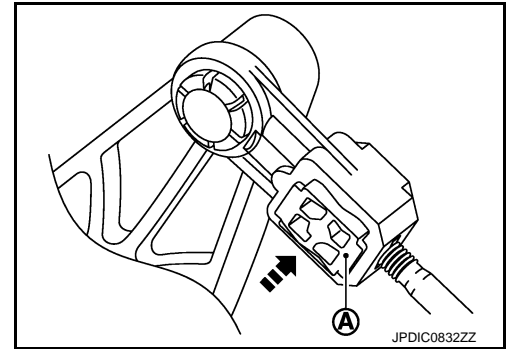

When M/T shift selector assembly is not replaced:

1. Install the selector cable to the M/T shift selector assembly.
2. Shift the shifter lever to the 4th gear position.
3. Adjust the length "L" between the stopper (A) and the lever to the standard value.

**Length "L" : 3.51 – 4.11 mm (0.1382 – 0.1618 in)**

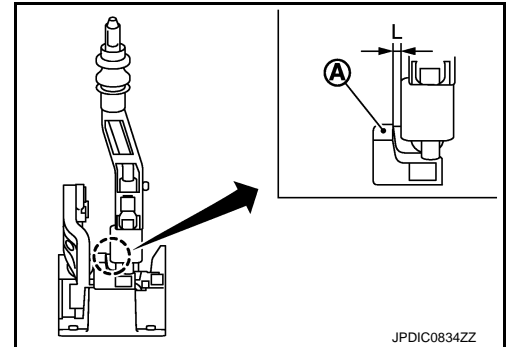

4. Insert the stopper (A) until it reaches the selector cable.
5. Shift the shifter lever to each gear position to check that there are no bindings. If any, repeat step 3.

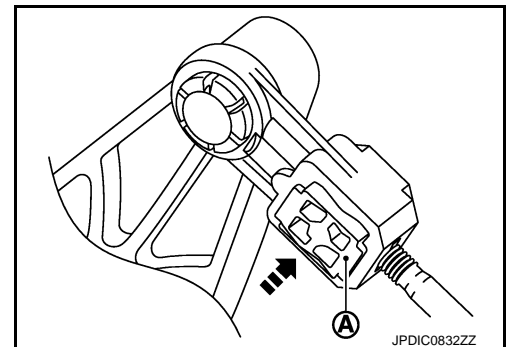

## Inspection

INFOID:000000009752461

### INSPECTION AFTER INSTALLATION

#### Shifter Lever Knob

Check that the shifter lever knob is installed in the right position.

#### Shifter Cable and Selector Cable

- Pull each cable in the removal direction to check that it dose not disconnect from the cable mounting bracket.
- Pull each cable in the removal direction to check that it dose not disconnect from the M/T shift selector assembly.
- Pull grommet in the removal direction to check that it dose not disconnect from the vehicle.

#### M/T Shift Selector Assembly and Shifter Lever

- Check that there is no tangle, hook, abnormal sound, looseness, and interference when the shifter lever is moved to each position. If there is a malfunction, then repair or replace the malfunctioning part.
- Check that the shifter lever smoothly returns to the neutral position after moving the lever from 1st to 2nd gear and moving hands off the lever. If there is a malfunction, then repair or replace the malfunctioning part.
- Check that the shifter lever smoothly returns to the neutral position after moving the lever from 5th to 6th gear and moving hands off the lever. If there is a malfunction, then repair or replace the malfunctioning part.



# AIR BREATHER HOSE

< REMOVAL AND INSTALLATION >

[6MT: RS6F94R]

## AIR BREATHER HOSE

### Exploded View

INFOID:000000009752462

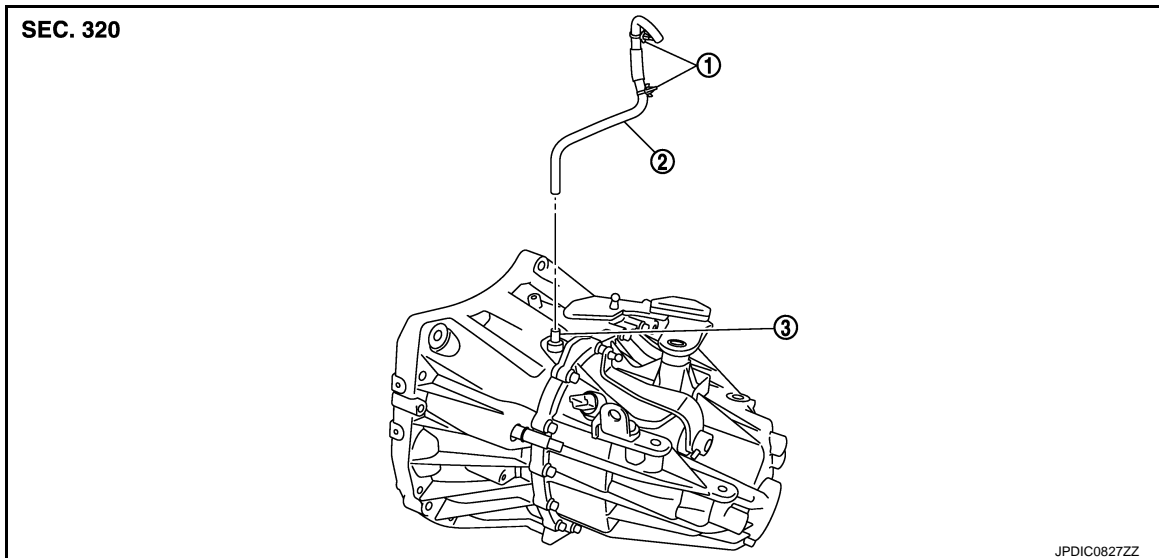

1. Clip

2. Air breather hose

3. 2 way connector

### Removal and Installation

INFOID:000000009752463

#### REMOVAL

1. Remove air cleaner case. Refer to [EM-25, "Removal and Installation"](#).
2. Remove clips (1).

← : Vehicle front

3. Remove air breather hose from the 2 way connector.

#### **CAUTION:**

**When removing air breather hose, be sure to hold 2 way connector securely.**

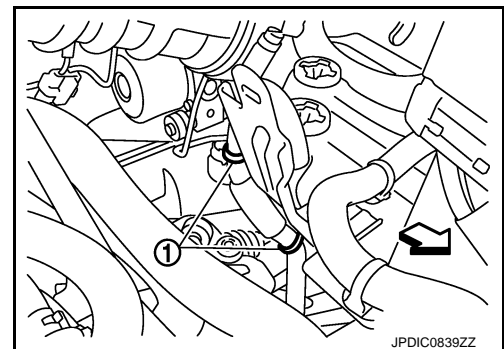

#### INSTALLATION

Note the following, and install in the reverse order of removal.

#### **CAUTION:**

- Install air breather hose, preventing crush and clogging caused by bending.
- Insert the allowance of air breather hose to the spool of the 2 way connector.
- Install air breather hose to the 2 way connector with the paint mark faced forward of the vehicle.
- Securely engage the clips in the mounting hole.

## UNIT REMOVAL AND INSTALLATION

### TRANSAXLE ASSEMBLY

#### Exploded View

INFOID:000000009752464

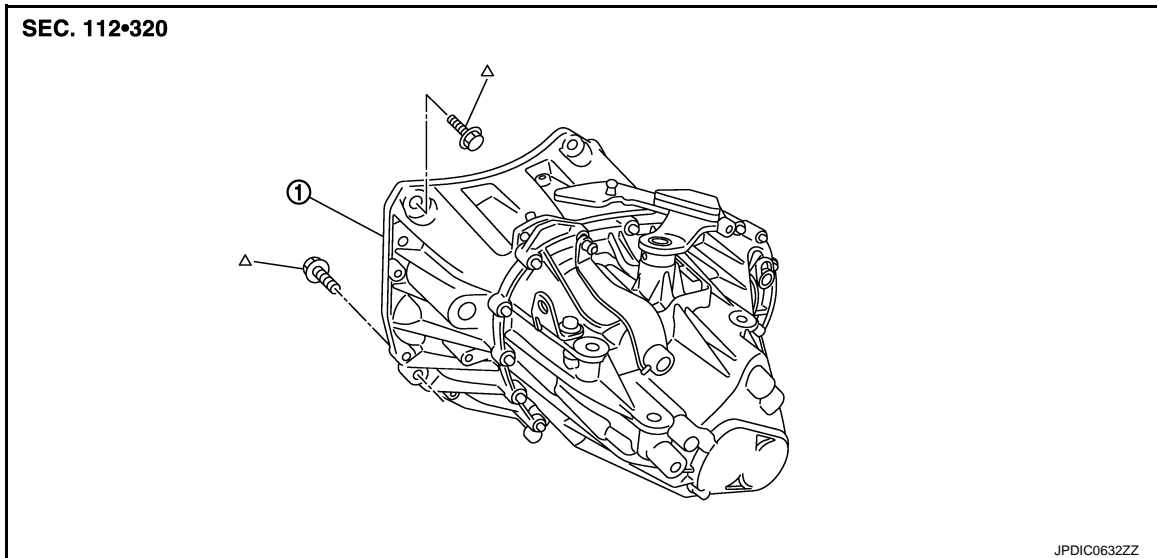

1. Transaxle assembly

△ : Refer to "INSTALLATION" in [TM-26, "Removal and Installation"](#) for the locations and tightening torque.

#### Removal and Installation

INFOID:000000009752465

#### **CAUTION:**

**Never reuse CSC (Concentric Slave Cylinder). Because CSC slides back to the original position every time when removing transaxle assembly. At this timing, dust on the sliding parts may damage a seal of CSC and may cause clutch fluid leakage. Refer to [CL-17, "Removal and Installation"](#).**

#### REMOVAL

1. Disconnect battery cable from negative terminal. Refer to [PG-99, "Removal and Installation"](#).
2. Shift the shifter lever to the neutral position.
3. Remove battery. Refer to [PG-99, "Removal and Installation"](#).
4. Remove air cleaner case. Refer to [EM-25, "Removal and Installation"](#).
5. Remove air breather hose. Refer to [TM-25, "Removal and Installation"](#).
6. Disconnect position switch connector. Refer to [TM-20, "Removal and Installation"](#).
7. Remove harness clip from transaxle assembly.
8. Disconnect selector cable and shifter cable from transaxle assembly. Refer to [TM-21, "Removal and Installation"](#).
9. Remove starter motor. Refer to [STR-37, "Removal and Installation"](#).
10. Remove clutch tube from CSC (Concentric Slave Cylinder). Refer to [CL-15, "Removal and Installation"](#).

#### **CAUTION:**

- Keep painted surface on the body or other parts free of clutch fluid. If it spills, wipe up immediately and wash the affected area with water.
- Never depress clutch pedal during removal procedure.

11. Remove engine under cover.
12. Remove fender protector LH. Refer to [EXT-27, "Removal and Installation"](#).
13. Disconnect ground cable.
14. Remove front suspension member. Refer to [FSU-15, "Removal and Installation"](#).

# TRANSAXLE ASSEMBLY

< UNIT REMOVAL AND INSTALLATION >

[6MT: RS6F94R]

- Remove front drive shafts. Refer to [FAX-20, "LEFT SIDE : Removal and Installation"](#) (LEFT SIDE) and [FAX-22, "RIGHT SIDE : Removal and Installation"](#) (RIGHT SIDE).

**NOTE:**

Insert a suitable plug into differential side oil seal after removing front drive shaft.

- Set a suitable jack to transaxle assembly and then set a suitable jack to engine assembly.

**CAUTION:**

**When setting a suitable jack, be careful so that it does not contact with the switch.**

- Remove engine mounting bracket (LH) mounting bolts from transaxle assembly. Refer to [EM-61, "2WD : Removal and Installation"](#).

- Remove rear torque rod bracket and rear torque rod. Refer to [EM-61, "2WD : Removal and Installation"](#).

- Remove transaxle assembly mounting bolts.

- Remove transaxle assembly from the engine.

**CAUTION:**

- **Fix transaxle assembly to a suitable jack.**
- **The transaxle assembly must not interfere with the wire harnesses and clutch tube.**

- Remove CSC. Refer to [CL-17, "Removal and Installation"](#).

## INSTALLATION

Note the following, and install in the reverse order of removal.

**CAUTION:**

- **Fix transaxle assembly to a suitable jack.**
- **The transaxle assembly must not interfere with the wire harnesses and clutch tube.**
- **When installing transaxle assembly, never bring input shaft into contact with clutch cover.**
- **Tapping work for tapping bolts is not applied to new transaxle case. Do not perform tapping by other than screwing tapping bolts because tapping is formed by screwing tapping bolts into transaxle case.**
- Tighten transaxle assembly mounting bolts to the specified torque.  
The figure is the view from the engine.

Bolt symbol	A	B
Insertion direction	Transaxle to engine	Engine to transaxle
Quantity	3	6
Bolt length "ℓ" mm (in)	60 (2.36)	50 (1.97)
Tightening torque N·m (kg·m, ft·lb)	62.0 (6.3, 46)	

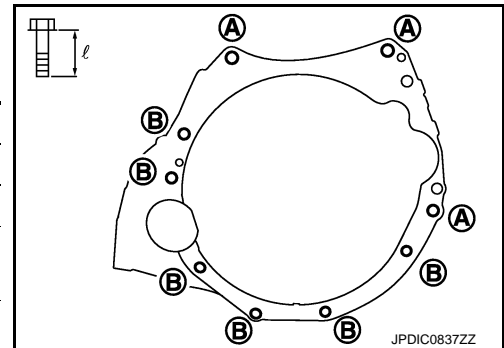

INFOID:000000009752466

## Inspection

### INSPECTION AFTER INSTALLATION

- Check the operation of the control linkage. Refer to [TM-24, "Inspection"](#).
- Check the oil leakage and the oil level. Refer to [TM-18, "Inspection"](#).

# TRANSAXLE ASSEMBLY

< UNIT DISASSEMBLY AND ASSEMBLY >

[6MT: RS6F94R]

## UNIT DISASSEMBLY AND ASSEMBLY

### TRANSAXLE ASSEMBLY

Exploded View

INFOID:000000009752467

#### CASE AND HOUSING

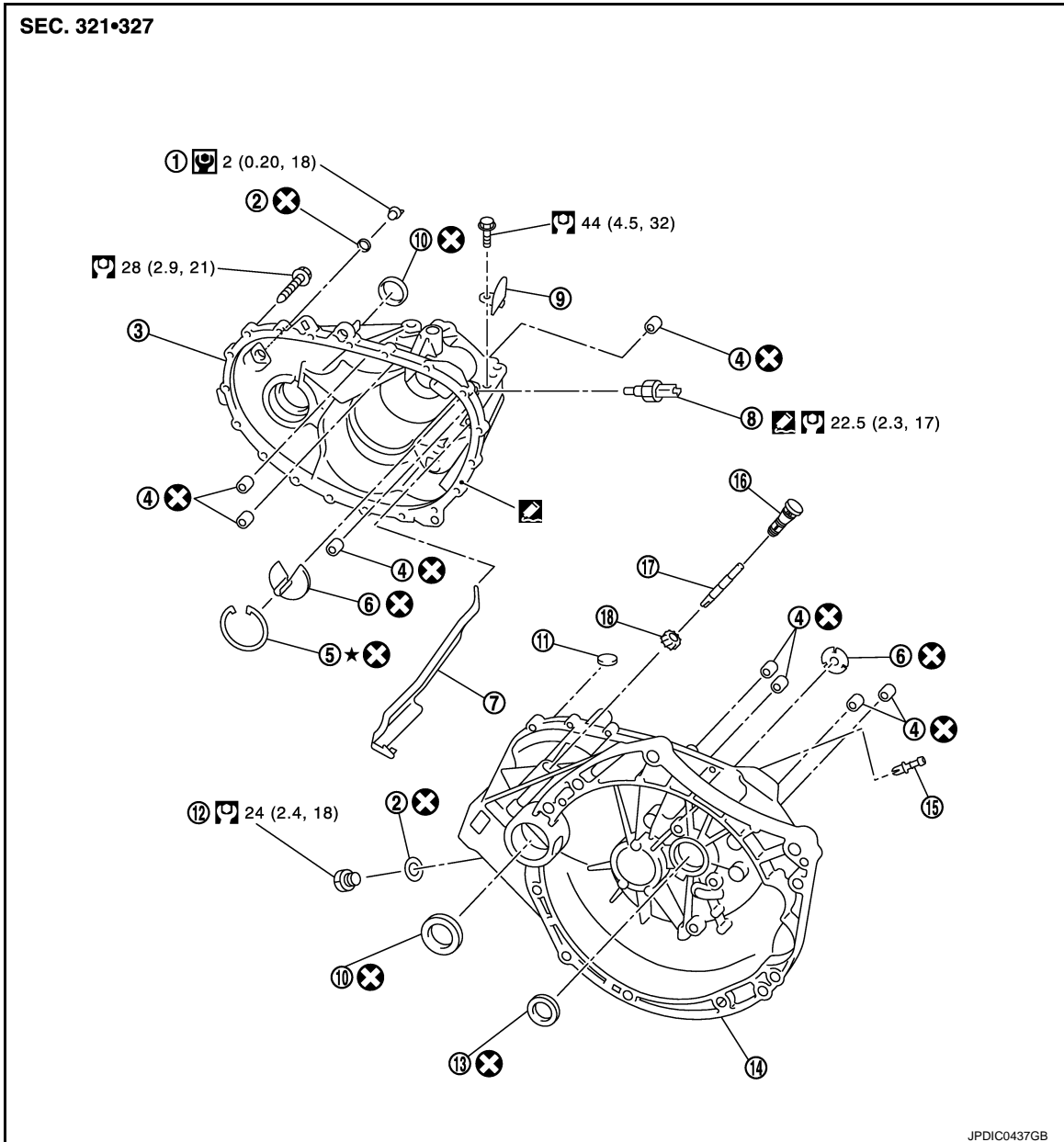

- |                                |                    |                     |
|--------------------------------|--------------------|---------------------|
| 1. Filler plug                 | 2. Gasket          | 3. Transaxle case   |
| 4. Bushing                     | 5. Snap ring       | 6. Oil channel      |
| 7. Oil gutter                  | 8. Position switch | 9. Bracket          |
| 10. Differential side oil seal | 11. Magnet         | 12. Drain plug      |
| 13. Input shaft oil seal       | 14. Clutch housing | 15. 2 way connector |
| 16. Plug                       | 17. Pinion shaft   | 18. Pinion gear     |

: Apply Genuine Silicone RTV or an equivalent. Refer to [GI-24, "Recommended Chemical Products and Sealants"](#).

: Always replace after every disassembly.

# TRANSAXLE ASSEMBLY

< UNIT DISASSEMBLY AND ASSEMBLY >

[6MT: RS6F94R]

★ : Select with proper thickness.

: N·m (kg-m, ft-lb)

: N·m (kg-m, in-lb)

## SHAFT AND GEAR

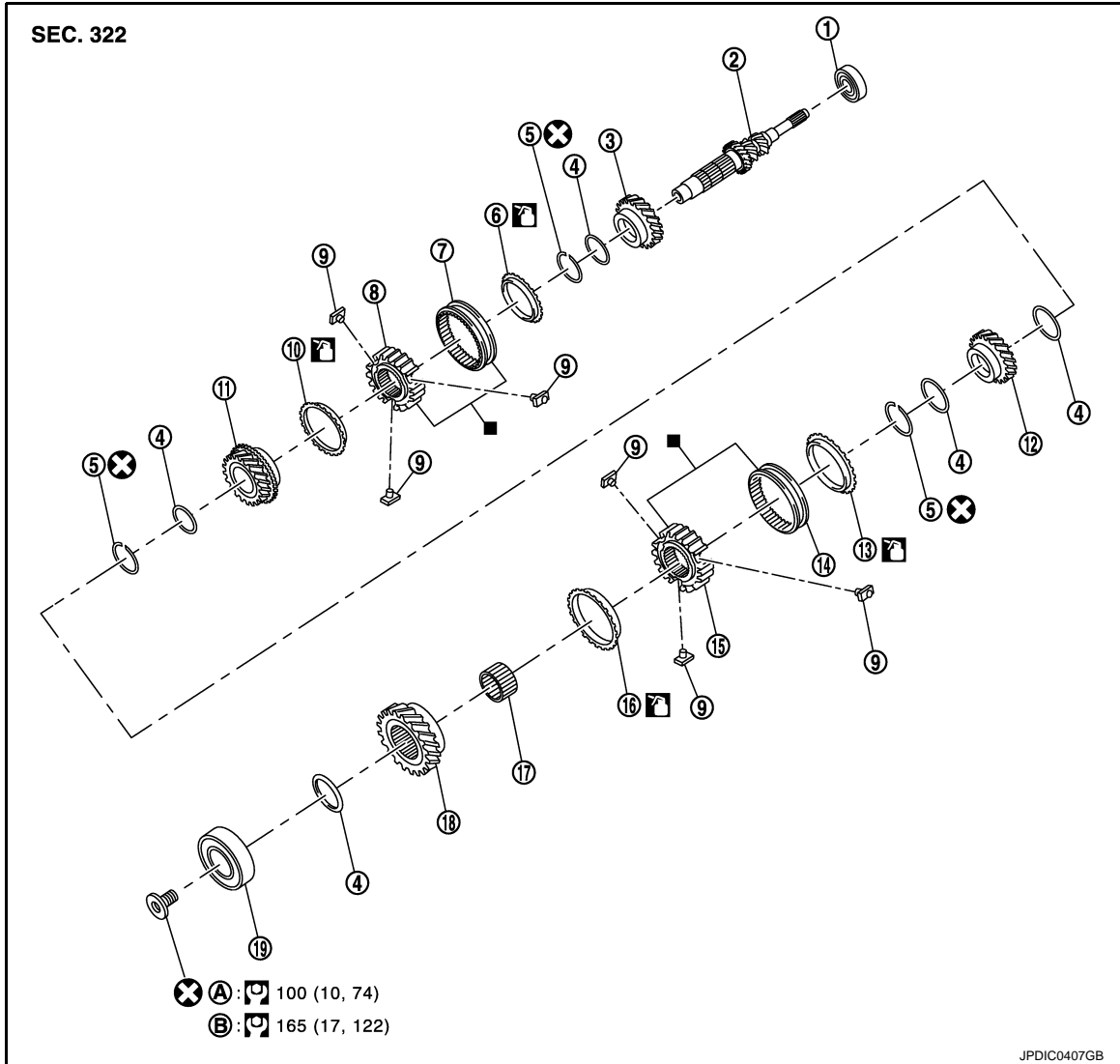

- |                              |                             |                              |
|------------------------------|-----------------------------|------------------------------|
| 1. Input shaft front bearing | 2. Input shaft              | 3. 3rd input gear            |
| 4. Spacer                    | 5. Snap ring                | 6. 3rd baulk ring            |
| 7. 3rd-4th coupling sleeve   | 8. 3rd-4th synchronizer hub | 9. Insert key                |
| 10. 4th baulk ring           | 11. 4th input gear          | 12. 5th input gear           |
| 13. 5th baulk ring           | 14. 5th-6th coupling sleeve | 15. 5th-6th synchronizer hub |
| 16. 6th baulk ring           | 17. Needle bearing          | 18. 6th input gear           |
| 19. Input shaft rear bearing |                             |                              |
- A. First step                      B. Final step

: Apply gear oil.

: Replace the parts as a set.

: Always replace after every disassembly.

: N·m (kg-m, ft-lb)

A  
B  
C  
TM  
E  
F  
G  
H  
I  
J  
K  
L  
M  
N  
O  
P



# TRANSAXLE ASSEMBLY

< UNIT DISASSEMBLY AND ASSEMBLY >

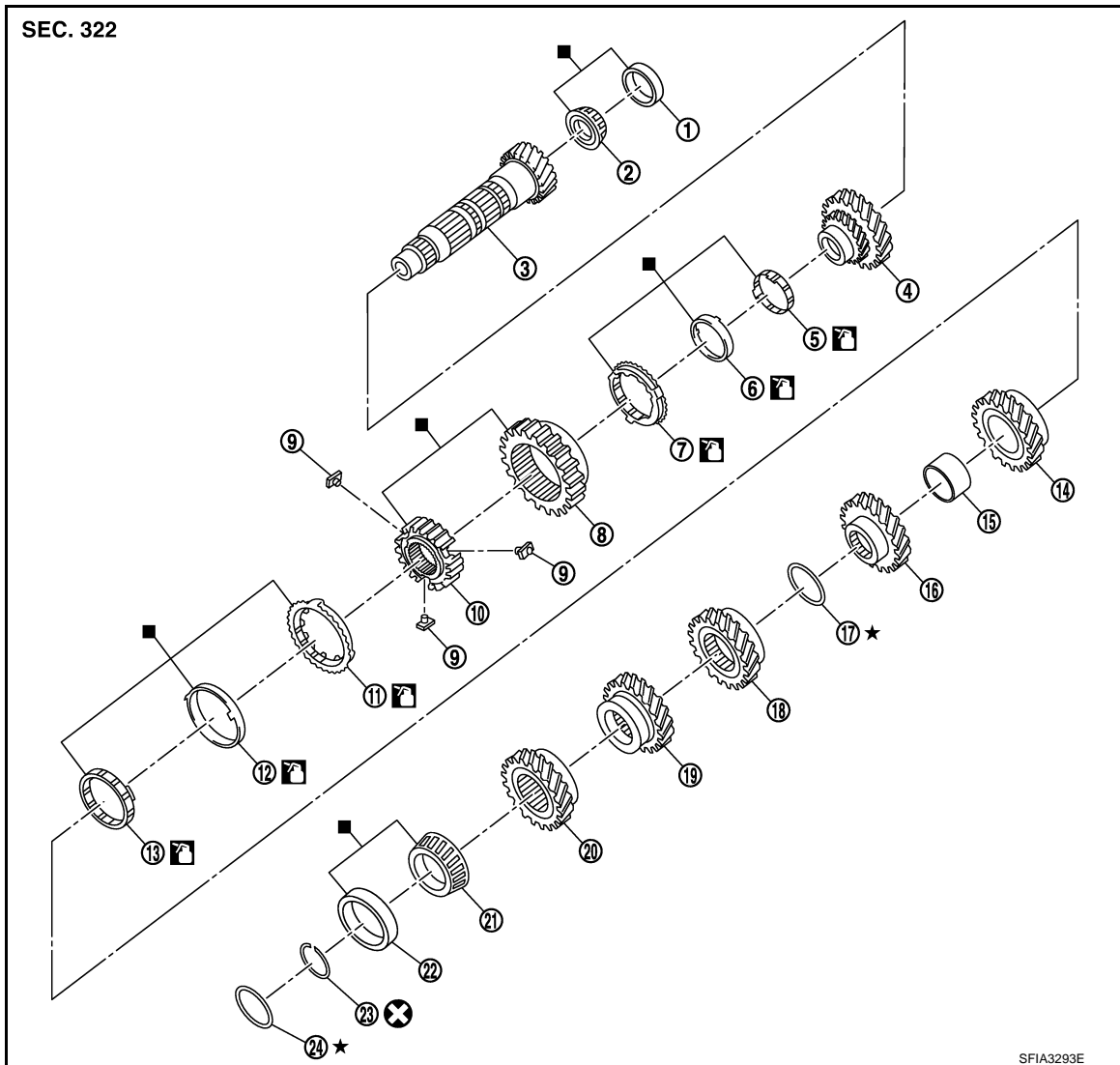
[6MT: RS6F94R]



- |                                       |                                       |   |
|---------------------------------------|---------------------------------------|---|
| 1. Mainshaft front bearing outer race | 2. Mainshaft front bearing inner race | 3. Mainshaft                              |
| 4. 1st main gear                      | 5. 1st inner baulk ring               | 6. 1st synchronizer cone                  |
| 7. 1st outer baulk ring               | 8. 1st-2nd coupling sleeve            | 9. Insert key                             |
| 10. 1st-2nd synchronizer hub          | 11. 2nd outer baulk ring              | 12. 2nd synchronizer cone                 |
| 13. 2nd inner baulk ring              | 14. 2nd main gear                     | 15. Bushing                               |
| 16. 3rd main gear                     | 17. Mainshaft adjusting shim          | 18. 4th main gear                         |
| 19. 5th main gear                     | 20. 6th main gear                     | 21. Mainshaft rear bearing inner race     |
| 22. Mainshaft rear bearing outer race | 23. Snap ring                         | 24. Mainshaft rear bearing adjusting shim |

-  : Apply gear oil.
-  : Replace the parts as a set.
- ★ : Select with proper thickness.
-  : Always replace after every disassembly.

SFIA3293E

# TRANSAXLE ASSEMBLY

< UNIT DISASSEMBLY AND ASSEMBLY >

[6MT: RS6F94R]

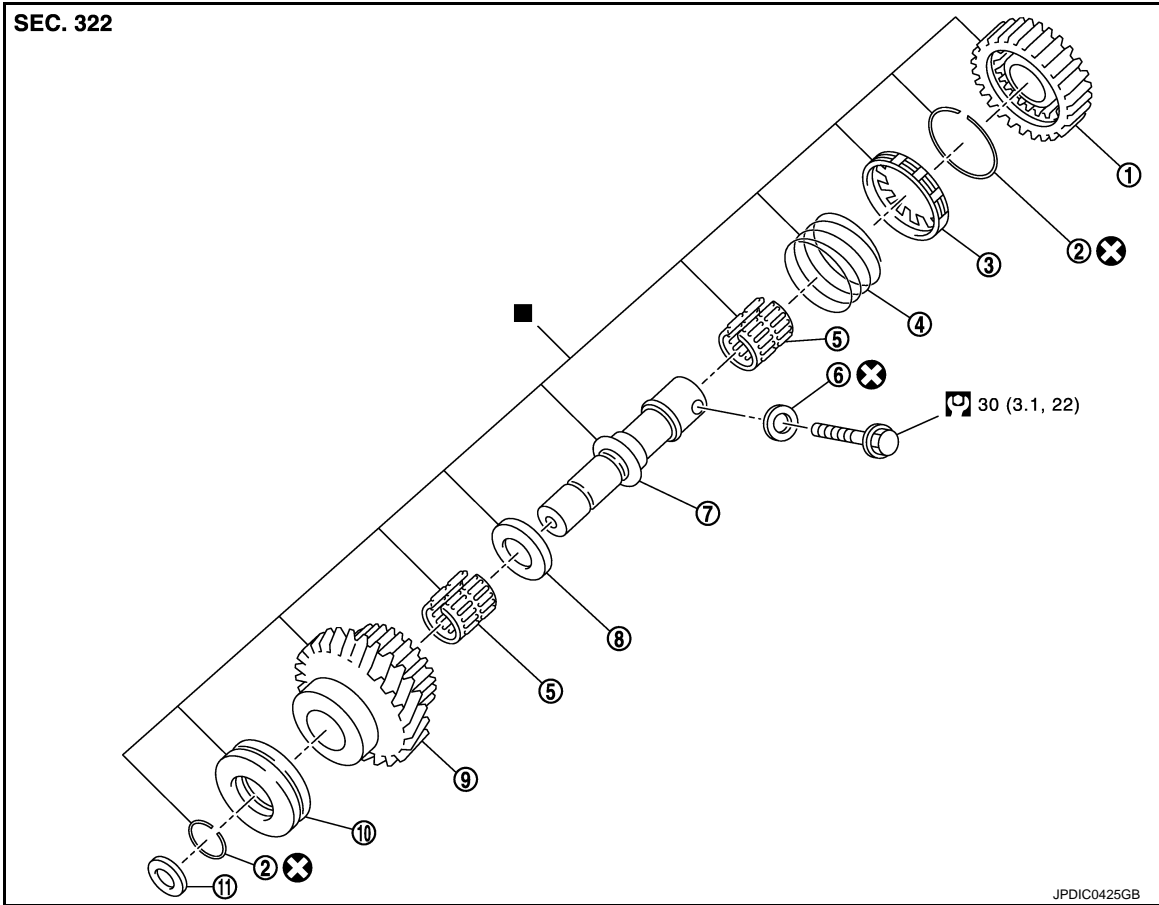

- |                        |                   |                       |
|------------------------|-------------------|-----------------------|
| 1. Reverse output gear | 2. Snap ring      | 3. Reverse baulk ring |
| 4. Return spring       | 5. Needle bearing | 6. Seal washer        |
| 7. Reverse idler shaft | 8. Spacer         | 9. Reverse input gear |
| 10. Lock washer        | 11. Spring washer |                       |

■ : Replace the parts as a set.

⊗ : Always replace after every disassembly.

🔧 : N·m (kg-m, ft-lb)

## SHIFT FORK AND FORK ROD

A  
B  
C  
TM  
E  
F  
G  
H  
I  
J  
K  
L  
M  
N  
O  
P

# TRANSAXLE ASSEMBLY

< UNIT DISASSEMBLY AND ASSEMBLY >

[6MT: RS6F94R]

## SEC. 328

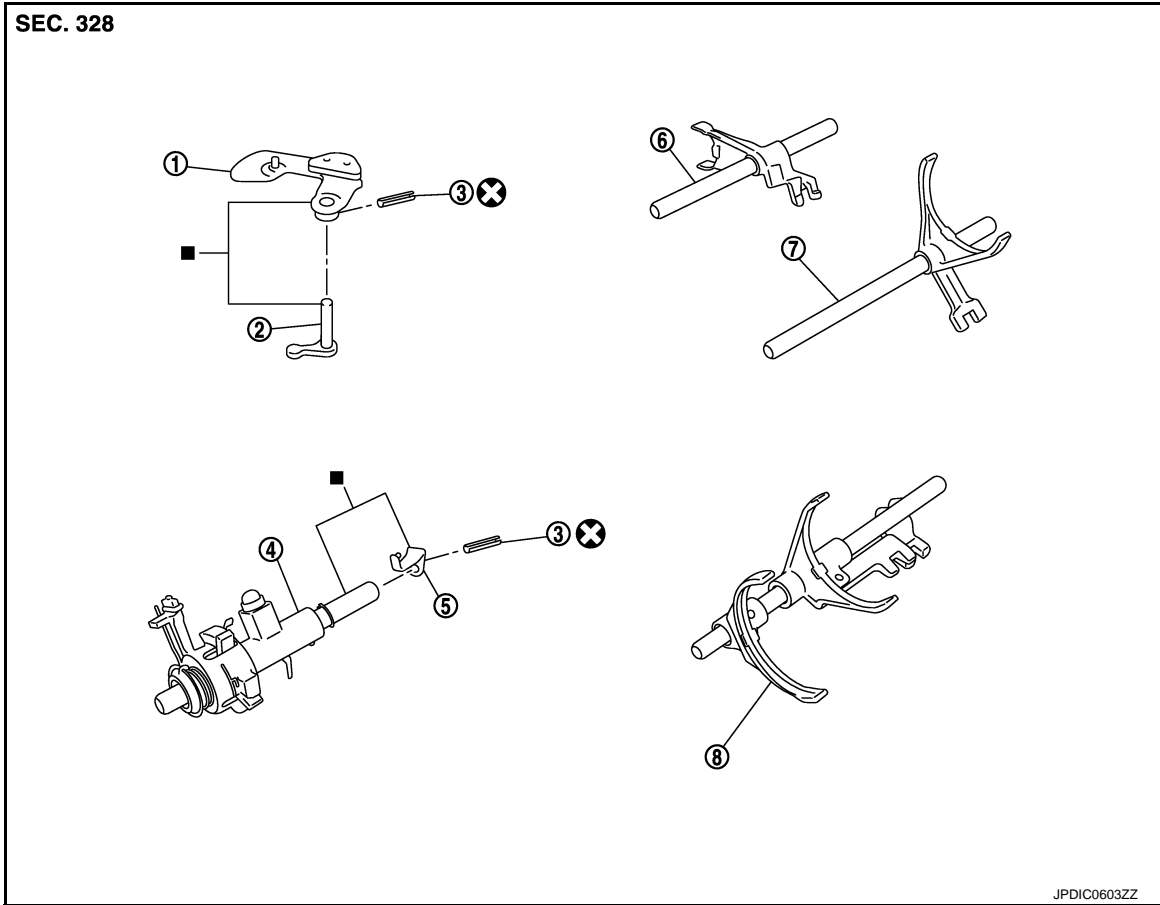

JPDIC0603ZZ

1. Shifter lever A

2. Shifter lever B

3. Retaining pin

4. Selector

5. Selector lever

6. Reverse fork rod

7. 1st-2nd fork rod

8. Fork rod

■ : Replace the parts as a set.

⊗ : Always replace after every disassembly.

## FINAL DRIVE



# TRANSAXLE ASSEMBLY

< UNIT DISASSEMBLY AND ASSEMBLY >

[6MT: RS6F94R]

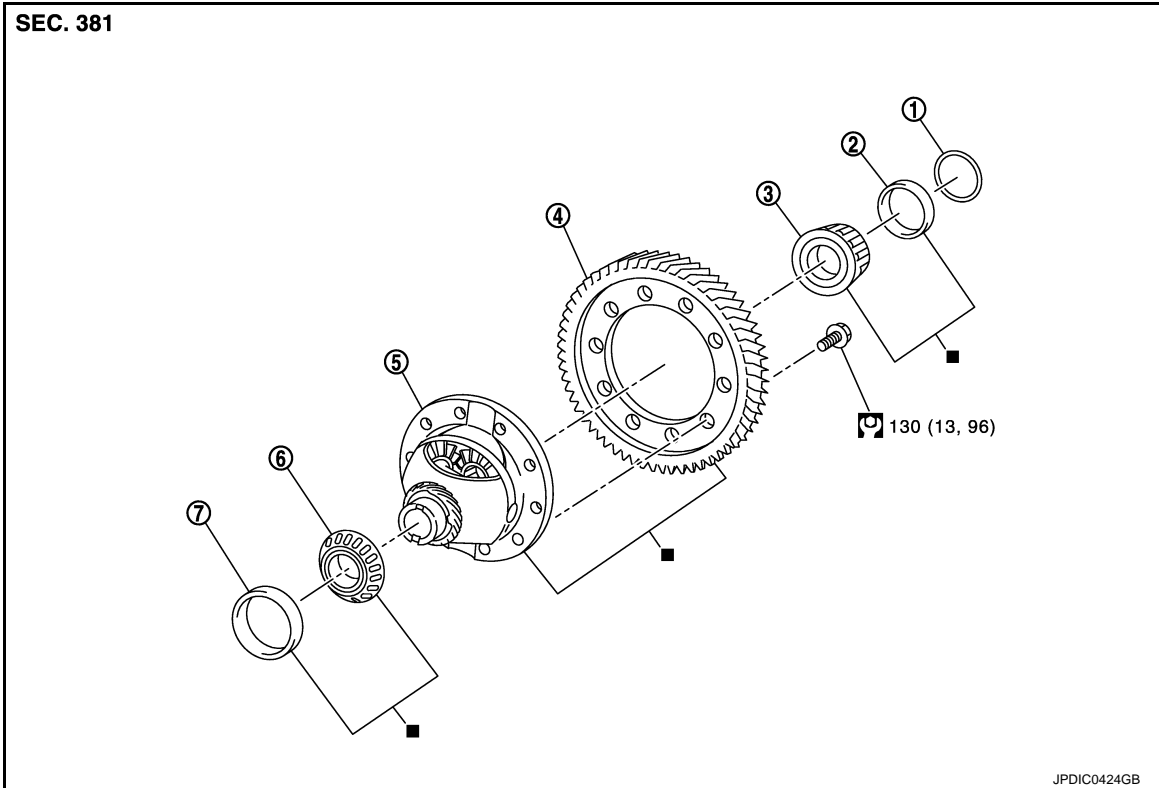

- |   |   |   |
|---|---|---|
| 1. Shim   | 2. Differential side bearing outer race (transaxle case side) | 3. Differential side bearing inner race (transaxle case side) |
| 4. Final gear   | 5. Differential case  | 6. Differential side bearing inner race (clutch housing side) |
| 7. Differential side bearing outer race (clutch housing side) |   |   |

■ : Replace the parts as a set.

⊕ : N·m (kg-m, ft-lb)

## Disassembly

INFOID:000000009752468

1. Remove drain plug and gasket from clutch housing, using a socket [Commercial service tool] and then drain gear oil.
2. Remove filler plug and gasket from transaxle case.
3. Remove selector lever (1) retaining pin with a pin punch to remove selector lever.
4. Remove bracket (2) and position switch (3) from transaxle case.

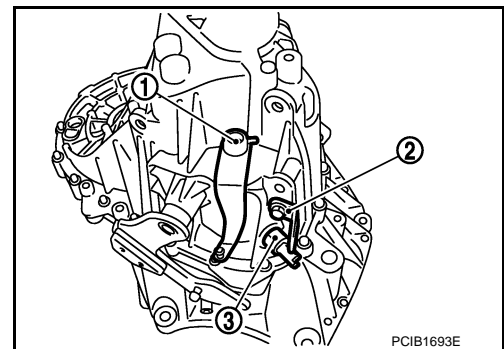

# TRANSAXLE ASSEMBLY

< UNIT DISASSEMBLY AND ASSEMBLY >

[6MT: RS6F94R]

5. Remove transaxle case mounting bolts (←).

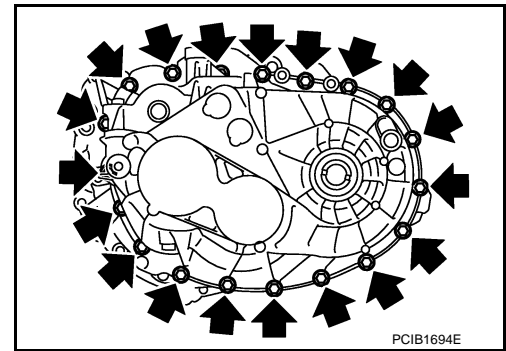

6. Remove reverse idler shaft mounting bolt (←) and seal washer.

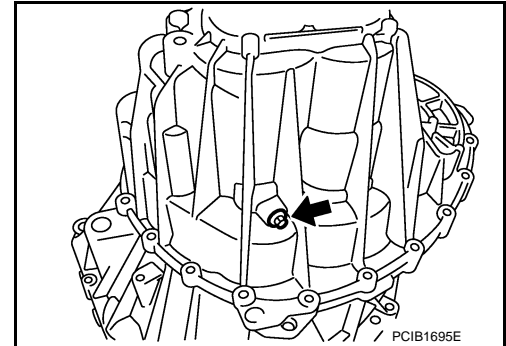

7. Remove transaxle case (2) while rotating shifter lever A (1) in the direction as shown in the figure.

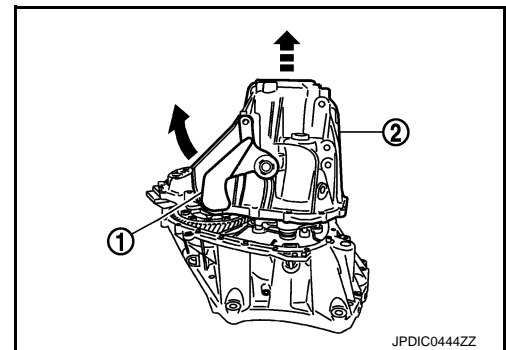

8. Remove selector spring (1) from return bushing (A).

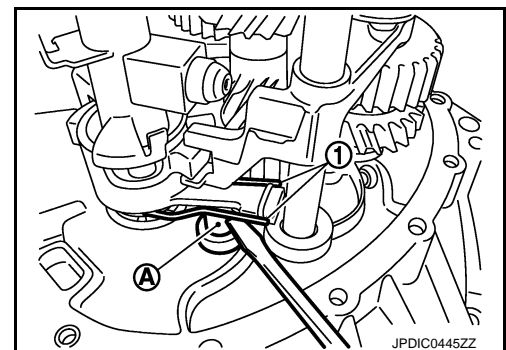

9. Shift 1st-2nd fork rod (1), fork rod (2), and reverse fork rod (3) to the neutral position.  
10. Remove selector (4) from clutch housing.

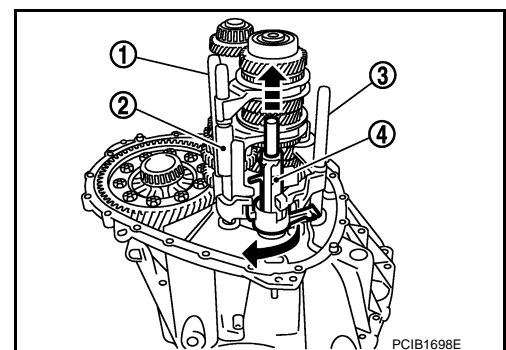

# TRANSAXLE ASSEMBLY

## < UNIT DISASSEMBLY AND ASSEMBLY >

[6MT: RS6F94R]

11. Remove reverse idler shaft assembly (1), as per the following procedure.

- a. Pull up input shaft assembly (2), mainshaft assembly (3), fork rod (4), and 1st-2nd fork rod (5).

**NOTE:**

It is easier to pull up when shifting each fork rod to each shaft side.

- b. Remove reverse idler shaft assembly and reverse fork rod (6) from clutch housing.

12. Remove spring washer from clutch housing.

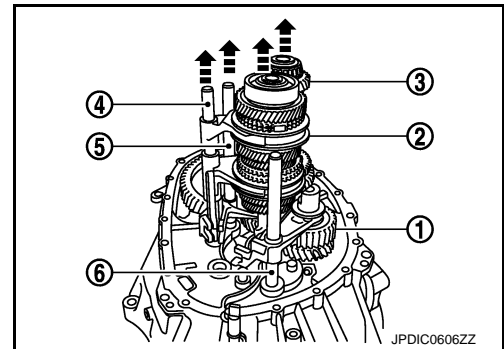

13. Pull up and remove input shaft assembly (1), mainshaft assembly (2), fork rod (3), and 1st-2nd fork rod (4) from clutch housing.

**NOTE:**

It is easier to pull up when shifting each fork rod to each shaft side.

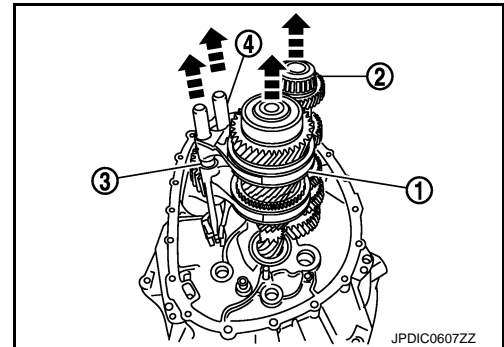

14. Remove final drive assembly (1) from clutch housing.

15. Remove magnet from clutch housing.

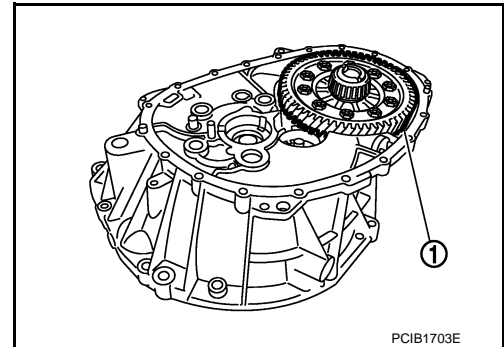

16. Remove differential side oil seals (1) from clutch housing and transaxle case.

**CAUTION:**

**Never damage clutch housing and transaxle case.**

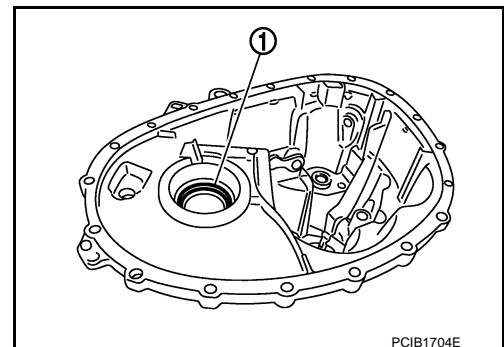

17. Remove differential side bearing outer race (1) from clutch housing, using a brass rod.

**CAUTION:**

**Never damage clutch housing.**

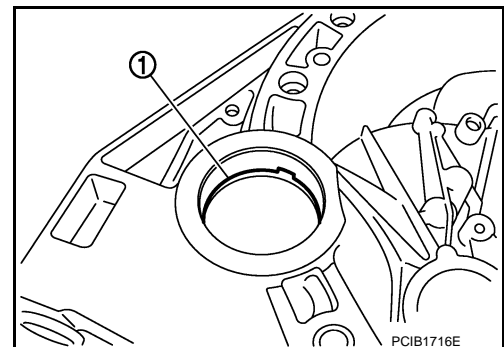

A  
B  
C  
TM  
E  
F  
G  
H  
I  
J  
K  
L  
M  
N  
O  
P

# TRANSAXLE ASSEMBLY

< UNIT DISASSEMBLY AND ASSEMBLY >

[6MT: RS6F94R]

18. Remove differential side bearing outer race (1) from transaxle case, using a brass rod.

**CAUTION:**

**Never damage transaxle case.**

19. Remove shim (2) from transaxle case.

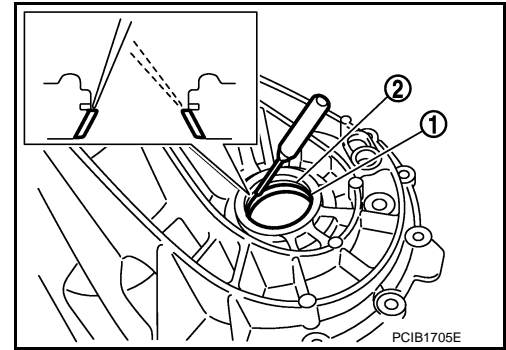

20. Remove shifter lever A (1) retaining pin, using a pin punch.  
21. Remove shifter lever A from transaxle case.

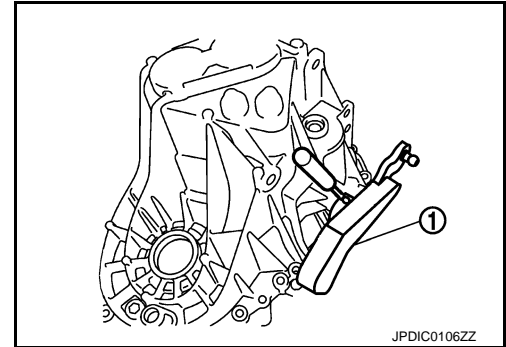

22. Remove shifter lever B (1) from transaxle case.

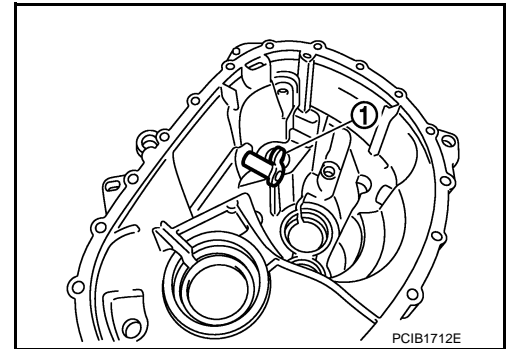

23. Remove oil gutter (1) from transaxle case.

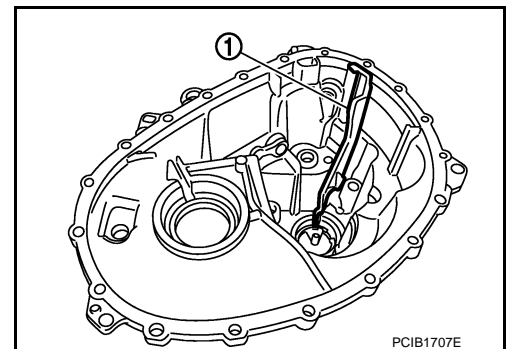

24. Remove bushings (1) from transaxle case, using a remover [Commercial service tool].

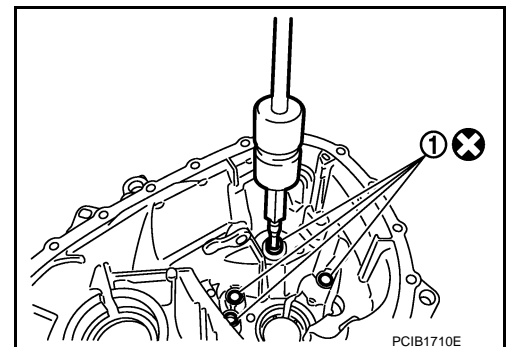

# TRANSAXLE ASSEMBLY

## < UNIT DISASSEMBLY AND ASSEMBLY >

[6MT: RS6F94R]

- 25. Remove mainshaft rear bearing outer race from transaxle case, using a remover [Commercial service tool].
- 26. Remove mainshaft rear bearing adjusting shim from transaxle case.

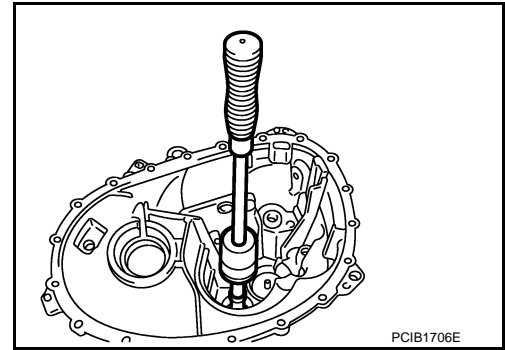

- 27. Remove snap ring (1) and oil channel (2) from transaxle case.

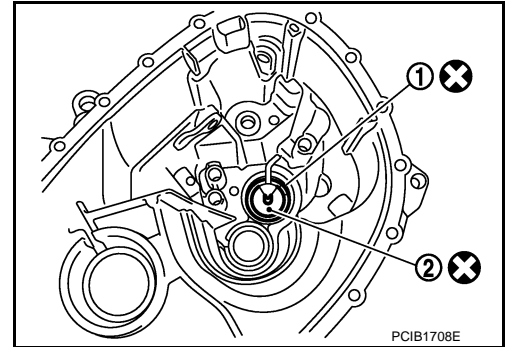

- 28. Remove input shaft oil seal (1) from clutch housing, using an oil seal remover.

**CAUTION:**  
Never damage clutch housing.

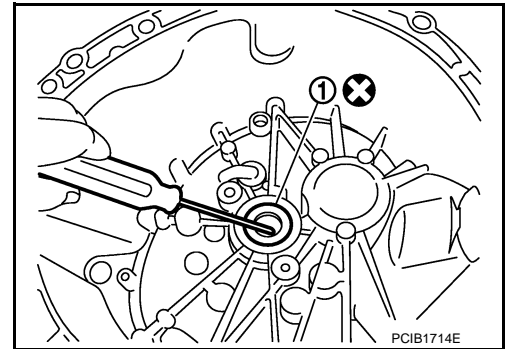

- 29. Remove mainshaft front bearing outer race (1) from clutch housing, using the puller (A) [SST: KV381054S0 (J-34286)] and a spacer (B) [Commercial service tool].

- 30. Remove oil channel (2) from clutch housing.

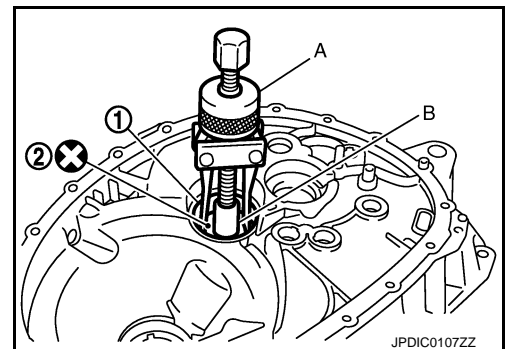

- 31. Remove bushing (1) from clutch housing, using a remover [Commercial service tool].

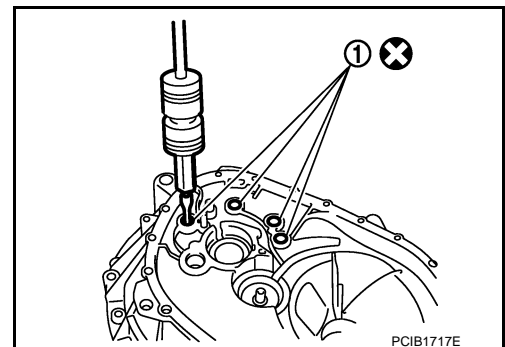

A  
B  
C  
TM  
E  
F  
G  
H  
I  
J  
K  
L  
M  
N  
O  
P

# TRANSAXLE ASSEMBLY

< UNIT DISASSEMBLY AND ASSEMBLY >

[6MT: RS6F94R]

32. Remove 2 way connector (1) from clutch housing.
33. Remove plug from clutch housing.

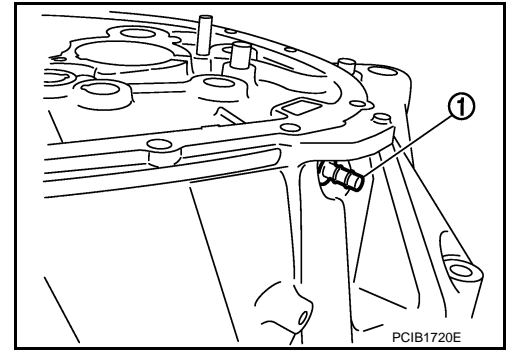

34. Remove pinion gear (1) and pinion shaft (2) from clutch housing.

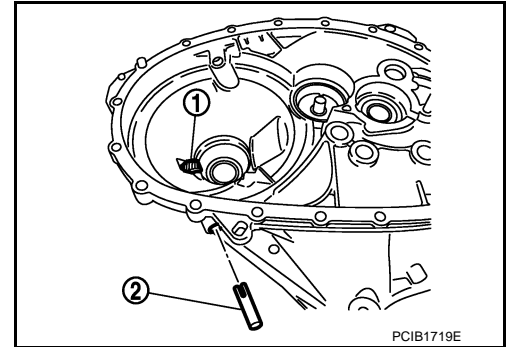

## Assembly

INFOID:000000009752469

1. Install pinion gear (1) and pinion shaft (2) to clutch housing.  
**CAUTION:**  
Replace transaxle assembly when replacing clutch housing.
2. Install plug to clutch housing.

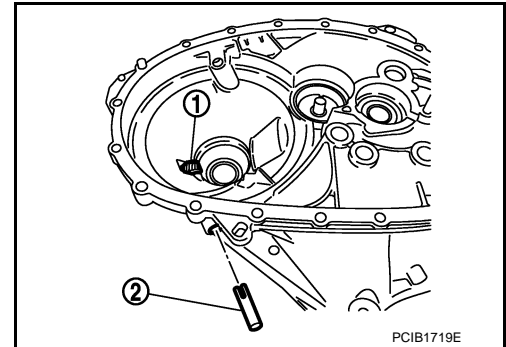

3. Install 2 way connector (1) to clutch housing.

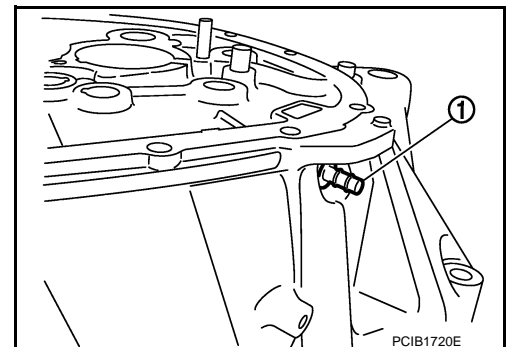

# TRANSAXLE ASSEMBLY

< UNIT DISASSEMBLY AND ASSEMBLY >

[6MT: RS6F94R]

4. Install bushings (1) so that they become even to clutch housing edge surface, using a drift (A) [Commercial service tool].
5. Install oil channel to clutch housing.

**CAUTION:**

Never reuse oil channel.

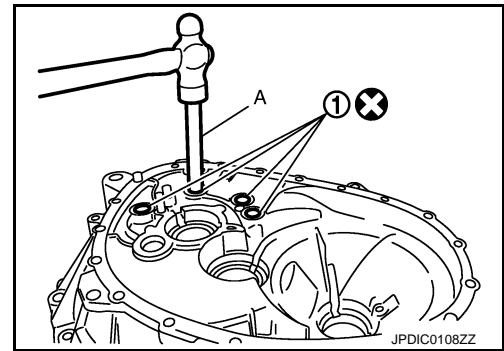

6. Install mainshaft front bearing outer race to clutch housing, using the drift (A) [SST: KV38100200 ( - )].

**CAUTION:**

Replace mainshaft front bearing outer race and mainshaft front bearing inner race as a set.

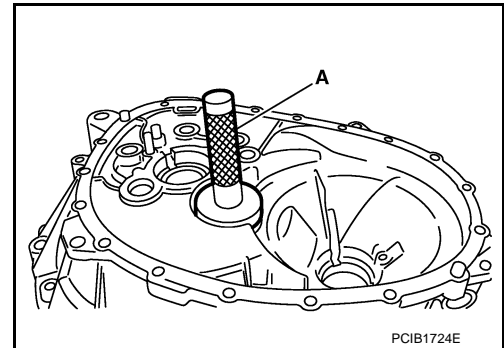

7. Install input shaft oil seal (1) to clutch housing, using the drift (A) [SST: ST33220000 ( - )].

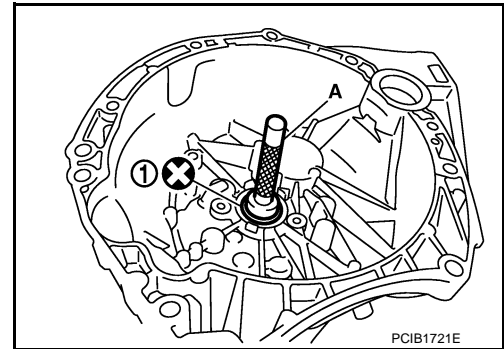

8. Install snap ring (1) and oil channel (2) to transaxle case.

**CAUTION:**

- Select and install snap ring that has the same thickness as previous one.
- Replace transaxle assembly when replacing transaxle case.

9. Install mainshaft rear bearing adjusting shim to transaxle case.

**CAUTION:**

Select mainshaft rear bearing adjusting shim, as per the following procedure when replacing mainshaft adjusting shim, 6th main gear, 5th main gear, or 4th main gear.

- Replace mainshaft adjusting shim.
  - If new mainshaft adjusting shim is thinner than previous one, offset the thickness difference by selecting thicker mainshaft rear bearing adjusting shim.
  - If new mainshaft adjusting shim is thicker than previous one, offset the thickness difference by selecting thinner mainshaft rear bearing adjusting shim.
- Replace 6th main gear, 5th main gear, or 4th main gear.
- Measure the thickness of the main gear used before and the new main gear
- Increase the thickness of the mainshaft rear bearing adjusting shim, if the difference is smaller than 0.025 mm (0.0010 in).
- Decrease the thickness of the mainshaft rear bearing adjusting shim, if the difference is greater than 0.025 mm (0.0010 in).

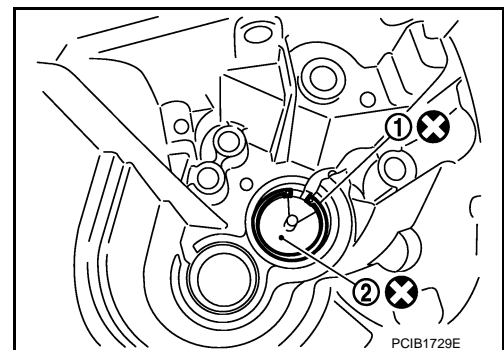

A  
B  
C  
TM  
E  
F  
G  
H  
I  
J  
K  
L  
M  
N  
O  
P

# TRANSAXLE ASSEMBLY

< UNIT DISASSEMBLY AND ASSEMBLY >

[6MT: RS6F94R]

10. Install mainshaft rear bearing outer race to transaxle case, using the drift (A) [SST: KV38100200 ( - )].

**CAUTION:**

Replace mainshaft rear bearing outer race and mainshaft rear bearing inner race as a set.

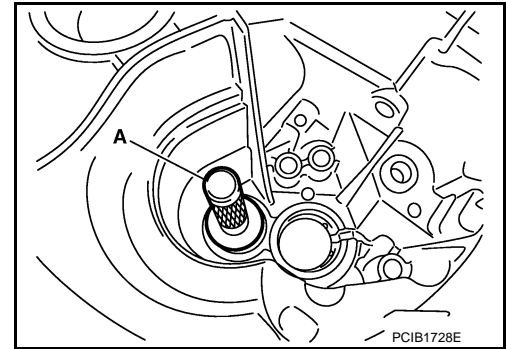

11. Install bushings (1) to transaxle case, using a drift (A) [Commercial service tool].

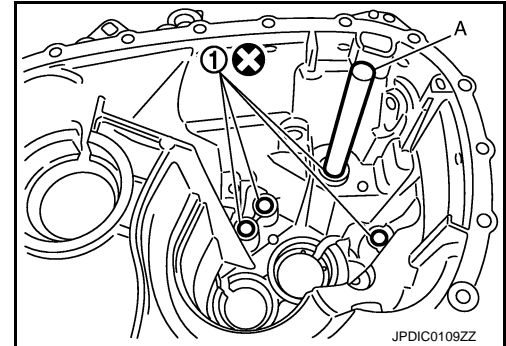

12. Install oil gutter (1) to transaxle case.

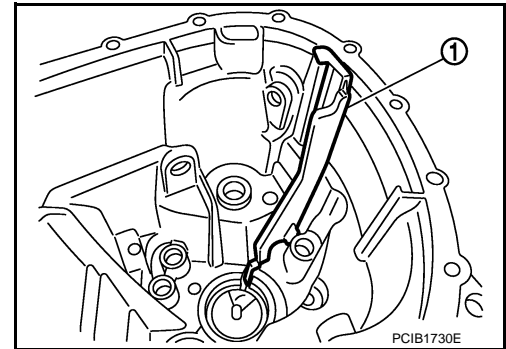

13. Install shifter lever B (1) to transaxle case.

**CAUTION:**

Replace shifter lever A and shifter lever B as a set.

14. Install shifter lever A to transaxle case.

**CAUTION:**

Replace shifter lever A and shifter lever B as a set.

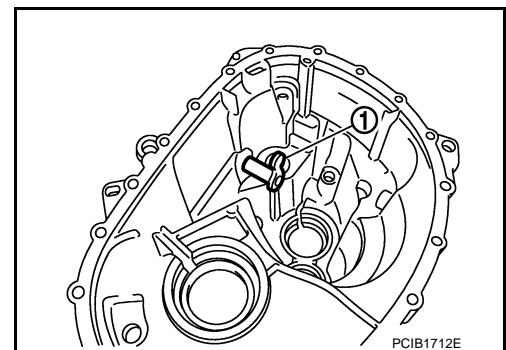

15. Install retaining pin to shifter lever A (1), using a pin punch.

**CAUTION:**

Never reuse retaining pin.

16. Install shim to transaxle case.

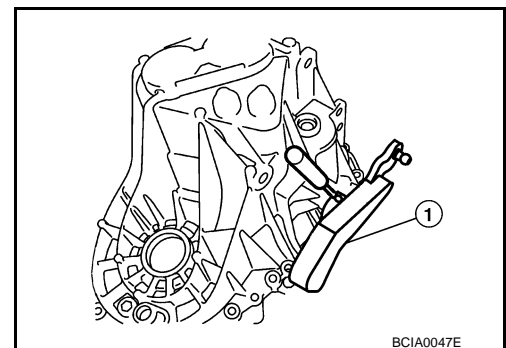



# TRANSAXLE ASSEMBLY

< UNIT DISASSEMBLY AND ASSEMBLY >

[6MT: RS6F94R]

17. Install differential side bearing outer race (transaxle case side) to transaxle case, using the drift (A) [SST: ST33400001 (J-26082)].

**CAUTION:**

Replace differential side bearing outer race (transaxle case side) and differential side bearing inner race (transaxle case side) as a set.

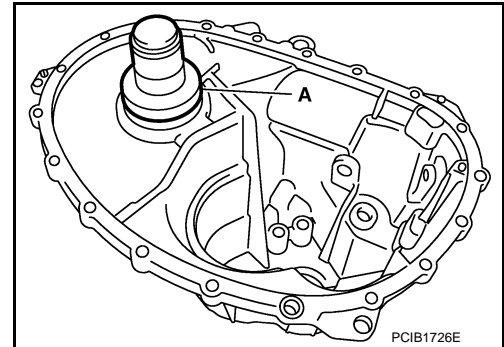

18. Install differential side bearing outer race (clutch housing side) to clutch housing, using the drift (A) [SST: KV38100200 (-)].

**CAUTION:**

Replace differential side bearing outer race (clutch housing side) and differential side bearing inner race (clutch housing side) as a set.

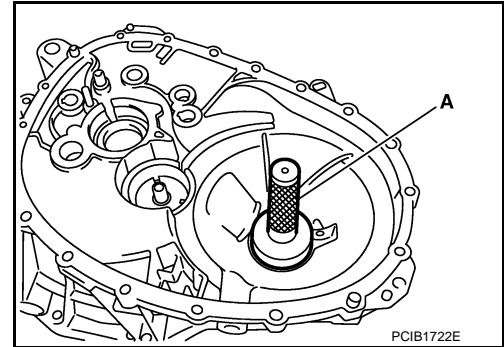

19. Install differential side oil seals (1) to clutch housing and transaxle case, using the drift [Stamping number: B.vi 1666-B] of the drift set [SST: KV32500QAA (-)].

A : Transaxle case side

B : Clutch housing side

Dimension "L1" : 1.2 – 1.8 mm (0.047 – 0.071 in)

Dimension "L2" : 2.7 – 3.3 mm (0.106 – 0.130 in)

**CAUTION:**

- Never incline differential side oil seal.
- Never damage clutch housing and transaxle case.

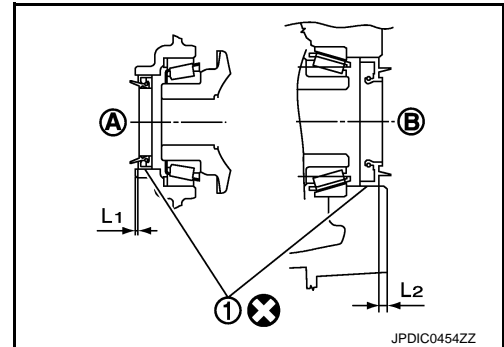

20. Install magnet to clutch housing.
21. Install final drive assembly to clutch housing.
22. Set fork rod (1) to input shaft assembly (2), and then install them to clutch housing.

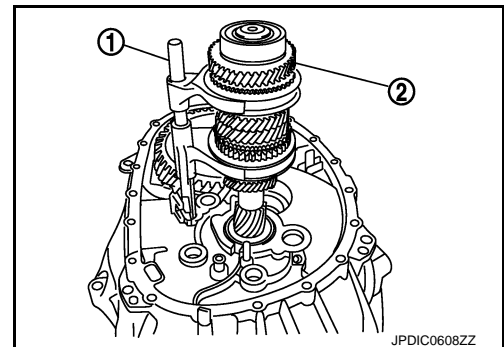

A  
B  
C  
TM  
E  
F  
G  
H  
I  
J  
K  
L  
M  
N  
O  
P

# TRANSAXLE ASSEMBLY

## < UNIT DISASSEMBLY AND ASSEMBLY >

[6MT: RS6F94R]

23. Install mainshaft assembly (1), as per the following procedure.

- a. Pull up input shaft assembly (2) and fork rod (3).
- b. Set 1st-2nd fork rod (4) to mainshaft assembly, and then install them to clutch housing.

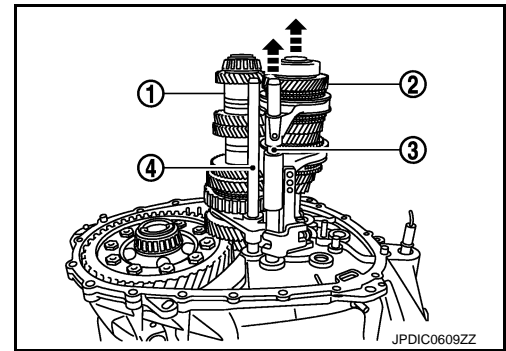

24. Install reverse idler shaft assembly (1), as per the following procedure.

- a. Install spring washer to clutch housing.
- b. Pull up input shaft assembly (2), mainshaft assembly (3), fork rod (4), and 1st-2nd fork rod (5).

**NOTE:**

It is easier to pull up when shifting each fork rod to each shaft side.

- c. Set reverse fork rod (6) to reverse idler shaft assembly, and then install them to clutch housing.

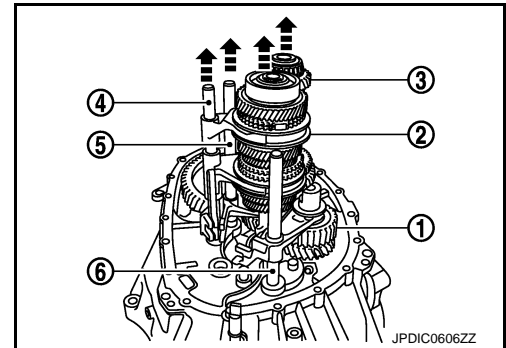

25. Shift 1st-2nd fork rod (1), fork rod (2), and reverse fork rod (3) to the neutral position.

26. Install selector (4) to clutch housing.

**CAUTION:**

Replace selector lever and selector as a set.

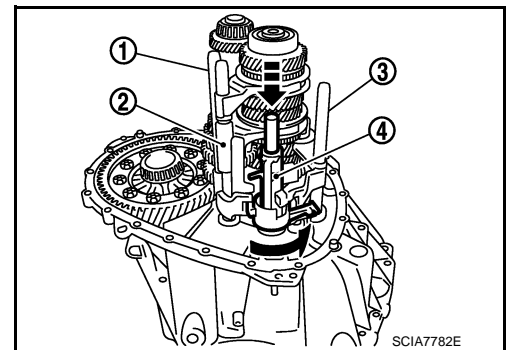

27. Install selector spring (1) to return bushing (A).

28. Apply recommended sealant to mounting surface of transaxle case.

- Use Genuine Silicone RTV or an equivalent. Refer to [GI-24, "Recommended Chemical Products and Sealants"](#).

**CAUTION:**

- Never allow old liquid gasket, moisture, oil, or foreign matter to remain on mounting surface.
- Check that mounting surface is not damaged.
- Apply sealant bead continuously.

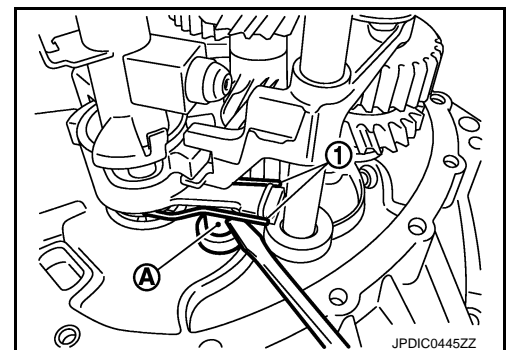

29. Install transaxle case to clutch housing while rotating shifter lever A (1) in the direction as shown in the figure.

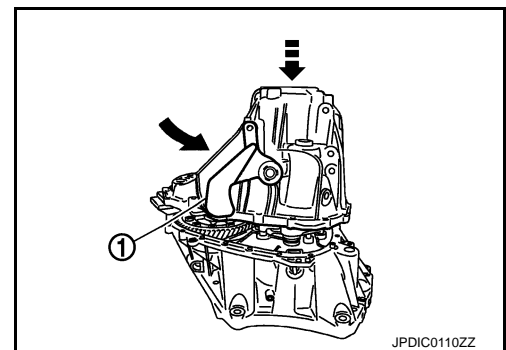

# TRANSAXLE ASSEMBLY

< UNIT DISASSEMBLY AND ASSEMBLY >

[6MT: RS6F94R]

30. Install reverse idler shaft mounting bolt (←), as per the following procedure.

a. Install seal washer to reverse idler shaft mounting bolt, and install reverse idler shaft mounting bolt to transaxle case.

**CAUTION:**

**Never reuse seal washer.**

b. Tighten reverse idler shaft mounting bolt to the specified torque.

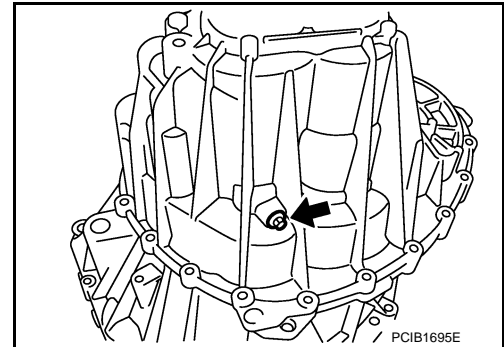

31. Tighten transaxle case mounting bolts (←) to the specified torque.

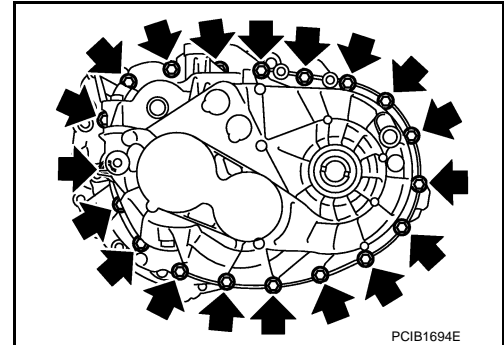

32. Install position switch (1), as per the following procedure.

a. Apply recommended sealant to threads of position switch.

• Use Genuine Silicone RTV or an equivalent. Refer to [GI-24, "Recommended Chemical Products and Sealants"](#).

**CAUTION:**

**Never allow old liquid gasket, moisture, oil, or foreign matter to remain on thread.**

b. Install position switch to transaxle case, and tighten it to the specified torque.

33. Install bracket (2) to transaxle case, and tighten mounting bolt to the specified torque.

34. Install selector lever (3), as per the following procedure.

a. Install selector lever to transaxle case.

**CAUTION:**

**Replace selector lever and selector as a set.**

b. Install retaining pin to selector lever, using a pin punch.

**CAUTION:**

**Never reuse retaining pin.**

35. Install drain plug, as per the following procedure.

a. Install gasket to drain plug.

**CAUTION:**

**Never reuse gasket.**

b. Install drain plug to clutch housing, using a socket [Commercial service tool].

c. Tighten drain plug to the specified torque.

36. Install filler plug, as per the following procedure.

a. Install gasket to filler plug, and then install them to transaxle case.

**CAUTION:**

**Never reuse gasket.**

b. Tighten filler plug to the specified torque.

**CAUTION:**

**Fill with gear oil before tighten filler plug to the specified torque.**

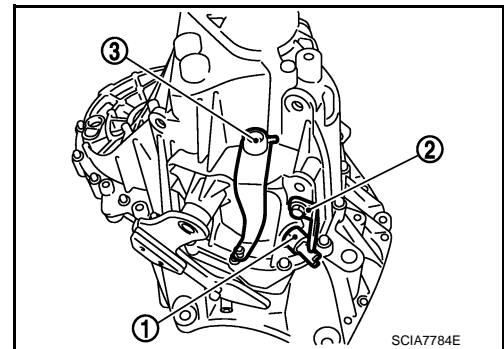

A  
B  
C  
TM  
E  
F  
G  
H  
I  
J  
K  
L  
M  
N  
O  
P

# TRANSAXLE ASSEMBLY

< UNIT DISASSEMBLY AND ASSEMBLY >

[6MT: RS6F94R]

## Inspection

INFOID:000000009752470

### INSPECTION AFTER DISASSEMBLY

Check contact surface and sliding surface for excessive wear, uneven wear, bend, and damage. Replace if necessary.

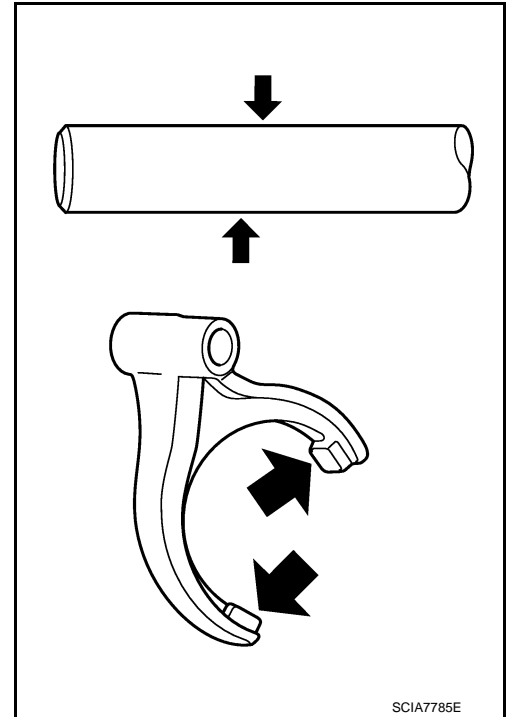

# INPUT SHAFT AND GEAR

< UNIT DISASSEMBLY AND ASSEMBLY >

[6MT: RS6F94R]

## INPUT SHAFT AND GEAR

Exploded View

INFOID:000000009752471

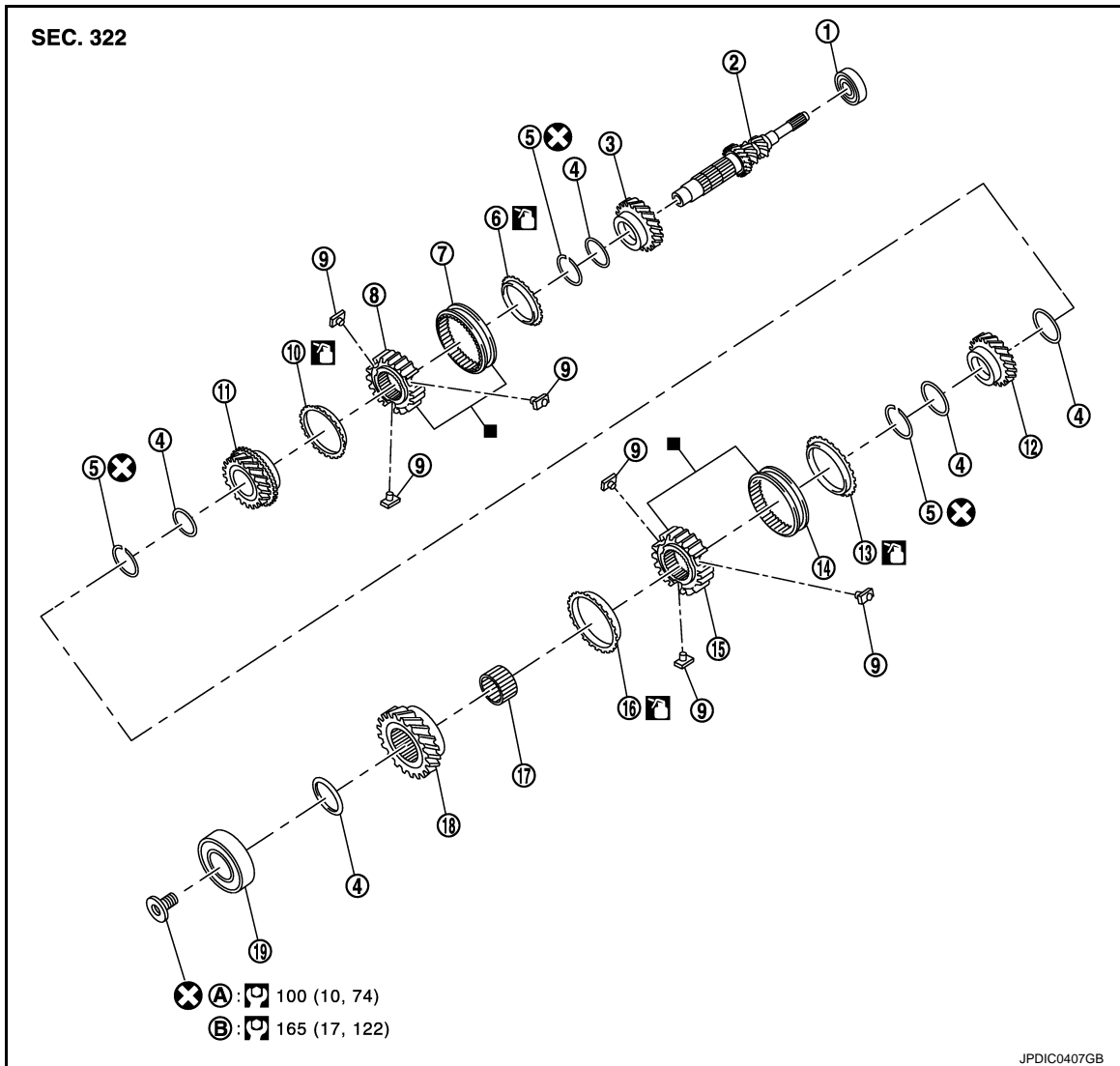

- |                              |                             |                              |
|------------------------------|-----------------------------|------------------------------|
| 1. Input shaft front bearing | 2. Input shaft              | 3. 3rd input gear            |
| 4. Spacer                    | 5. Snap ring                | 6. 3rd baulk ring            |
| 7. 3rd-4th coupling sleeve   | 8. 3rd-4th synchronizer hub | 9. Insert key                |
| 10. 4th baulk ring           | 11. 4th input gear          | 12. 5th input gear           |
| 13. 5th baulk ring           | 14. 5th-6th coupling sleeve | 15. 5th-6th synchronizer hub |
| 16. 6th baulk ring           | 17. Needle bearing          | 18. 6th input gear           |
| 19. Input shaft rear bearing |                             |                              |
| A. First step                | B. Final step               |                              |

: Apply gear oil.

: Replace the parts as a set.

: Always replace after every disassembly.

: N·m (kg·m, ft·lb)

### Disassembly

INFOID:000000009752472

**CAUTION:**

# INPUT SHAFT AND GEAR

< UNIT DISASSEMBLY AND ASSEMBLY >

[6MT: RS6F94R]

- Fix input shaft in a vise with back plate, and then remove gears and snap rings.
- For removal of snap ring, set snap ring pliers and flat pliers at both sides of snap ring. While expanding snap ring with snap ring pliers, move snap ring with flat pliers.
- Disassemble gear components putting direction marks on the parts that do not affect any functions.

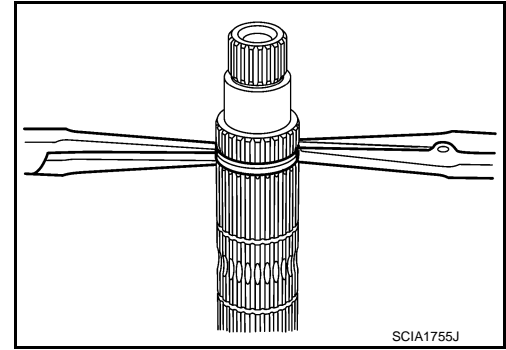

1. Remove input shaft rear bearing mounting bolt (1), using the drift (A) [SST: KV32300QAM (-)].

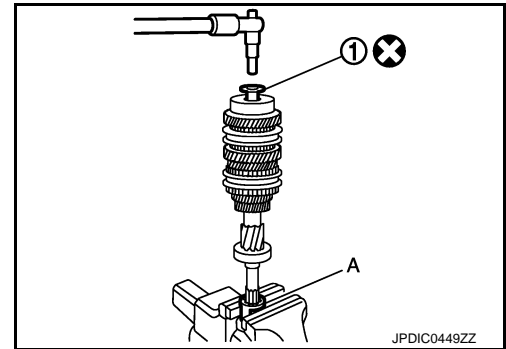

2. Remove input shaft rear bearing (1), as per the following procedure.
  - a. Set a puller [Commercial service tool] to input shaft rear bearing.
  - b. Remove input shaft rear bearing, using a drift (A) [Commercial service tool].

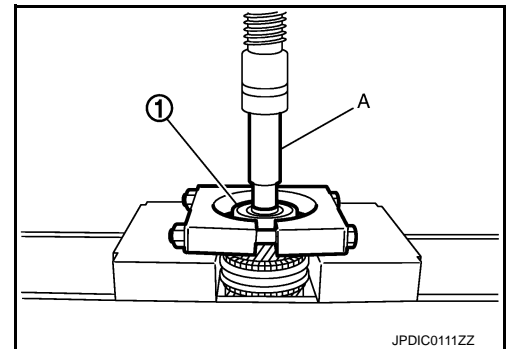

3. Remove spacer (1), 6th input gear (2), needle bearing, 6th baulk ring, and 5th-6th synchronizer hub assembly (3).
4. Remove insert keys and 5th-6th coupling sleeve from 5th-6th synchronizer hub.

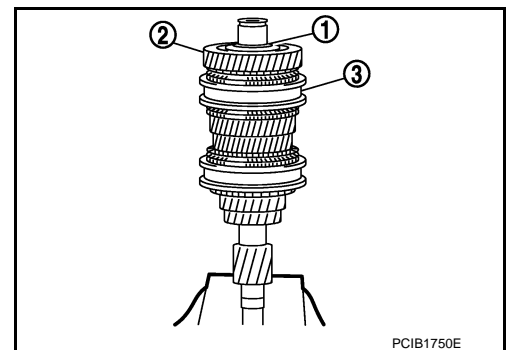

# INPUT SHAFT AND GEAR

< UNIT DISASSEMBLY AND ASSEMBLY >

[6MT: RS6F94R]

5. Remove snap ring (1).
6. Remove spacer, 5th baulk ring, 5th input gear (2), and spacer.

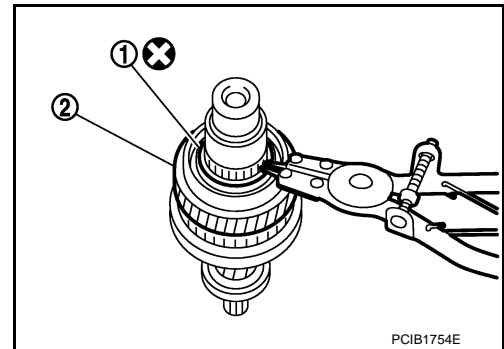

7. Remove snap ring (1).
8. Remove spacer, 4th input gear (2), 4th baulk ring, and 3rd-4th synchronizer hub assembly (3).
9. Remove insert keys and 3rd-4th coupling sleeve from 3rd-4th synchronizer hub.

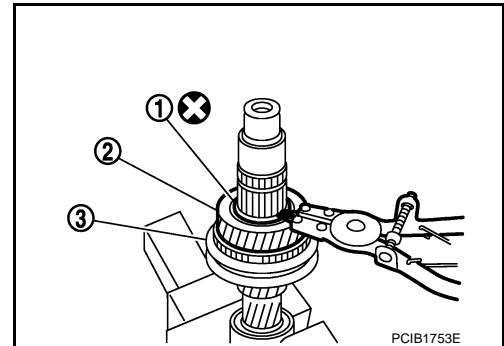

10. Remove snap ring (1).
11. Remove spacer, 3rd baulk ring, and 3rd input gear (2).

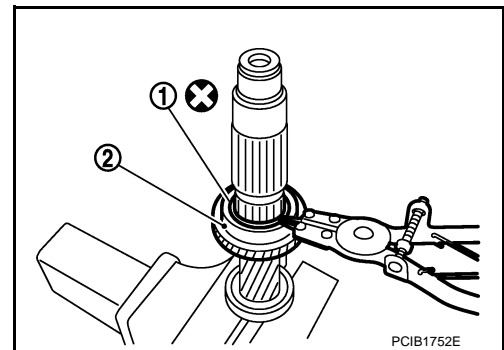

12. Set a puller [Commercial service tool] to input shaft front bearing (1), and then remove input shaft front bearing.

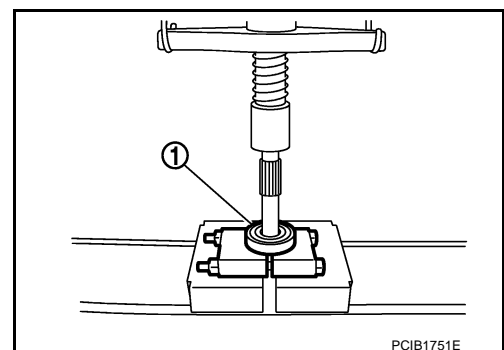

INFOID:000000009752473

## Assembly

Note the following procedures, and assemble in the reverse order of disassembly.

### CAUTION:

- Replace transaxle assembly when replacing input shaft.

# INPUT SHAFT AND GEAR

< UNIT DISASSEMBLY AND ASSEMBLY >

[6MT: RS6F94R]

- For installation of snap ring, set snap ring pliers and flat pliers at both sides of snap ring. While expanding snap ring with snap ring pliers, move snap ring with flat pliers.
- Never reuse snap ring.
- Check that snap ring is securely installed in a groove.
- Replace 3rd-4th coupling sleeve and 3rd-4th synchronizer hub as a set.
- Replace 5th-6th coupling sleeve and 5th-6th synchronizer hub as a set.

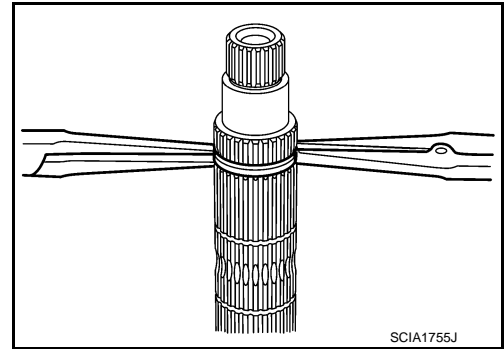

- Be careful to install 3rd-4th synchronizer hub according to the specified direction.

A : 3rd input gear side

B : 4th input gear side

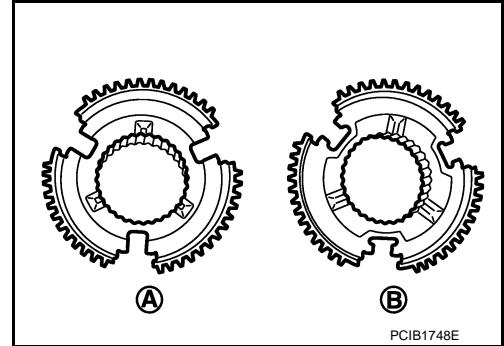

- Be careful to install 5th-6th synchronizer hub according to the specified direction.

A : 5th input gear side

B : 6th input gear side

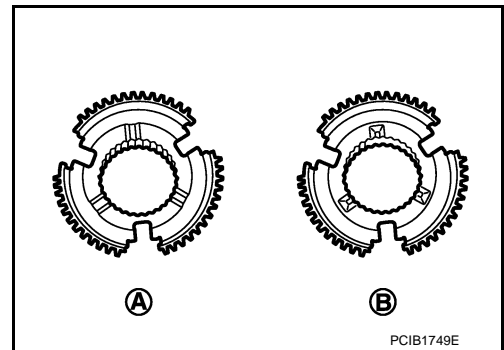

- Install input shaft front bearing (1), using a drift (A) [Commercial service tool].

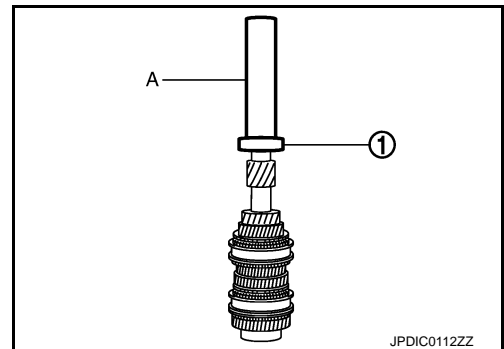



# INPUT SHAFT AND GEAR

< UNIT DISASSEMBLY AND ASSEMBLY >

[6MT: RS6F94R]

- Install input shaft rear bearing (1), using a drift (A) [Commercial service tool] and the drift (B) [SST: ST36720030 (-)].
- Apply gear oil to 3rd baulk ring, 4th baulk ring, 5th baulk ring, and 6th baulk ring.

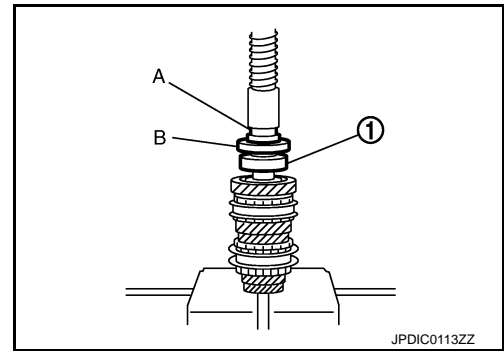

- Install input shaft rear bearing mounting bolt (1), as per the following procedure.

**CAUTION:**

**Follow the procedures. Otherwise it may cause a transaxle malfunction.**

1. Fix the drift (A) [SST: KV32300QAM (-)] in a vise, and then set input shaft assembly.
2. Install input shaft rear bearing mounting bolt, and then tighten it to the specified torque of the first step.
3. Loosen input shaft rear bearing mounting bolt by a half turn.
4. Tighten input shaft rear bearing mounting bolt to the specified torque of the final step.

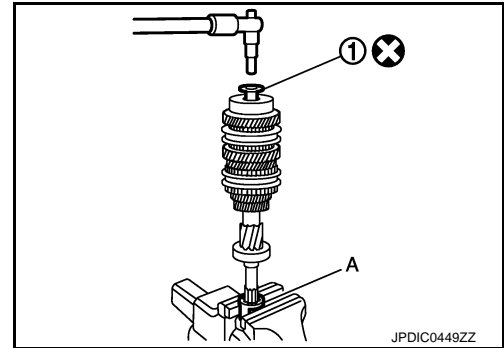

## Inspection

INFOID:000000009752474

### INSPECTION AFTER DISASSEMBLY

#### Input Shaft and Gear

Check the following items and replace if necessary.

- Damage, peeling, bend, uneven wear, and distortion of shaft.
- Excessive wear, damage, and peeling of gear.

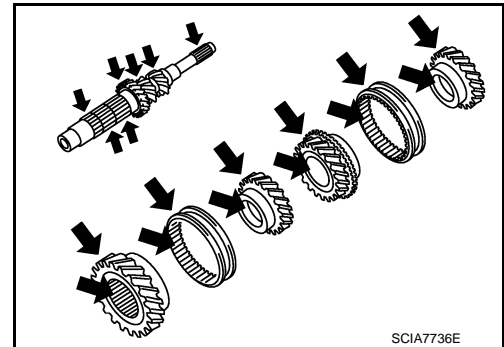

#### Synchronizer Hub and Coupling Sleeve

Check the following items and replace if necessary.

- Breakage, damage, and unusual wear on contact surface of coupling sleeve, synchronizer hub, and insert key.
- Coupling sleeve and synchronizer hub move smoothly.

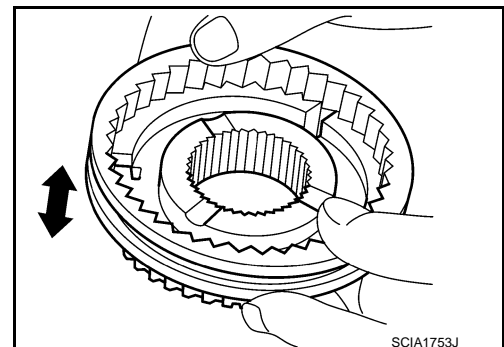

#### Baulk Ring

A  
B  
C  
TM  
E  
F  
G  
H  
I  
J  
K  
L  
M  
N  
O  
P

# INPUT SHAFT AND GEAR

< UNIT DISASSEMBLY AND ASSEMBLY >

[6MT: RS6F94R]

Check contact surface of baulk ring cam and insert key for excessive wear, uneven wear, bend, and damage. Replace if necessary.

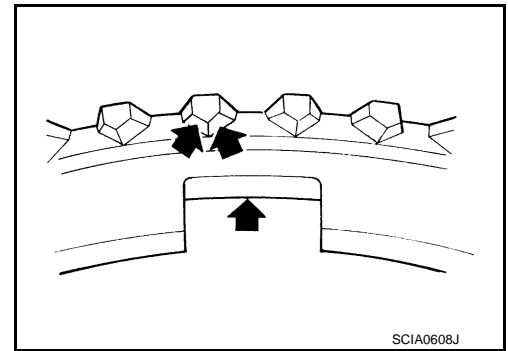

Bearing

Check bearing for damage and unsmooth rotation. Replace if necessary.

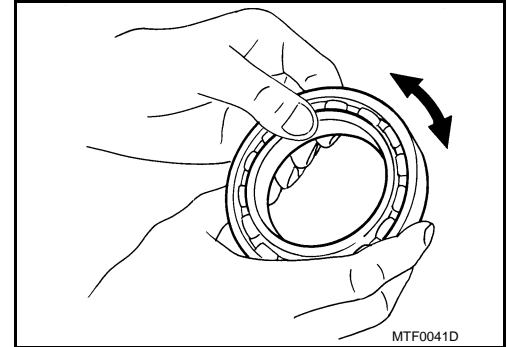

# MAINSHAFT AND GEAR

< UNIT DISASSEMBLY AND ASSEMBLY >

[6MT: RS6F94R]

## MAINSHAFT AND GEAR

Exploded View

INFOID:000000009752475

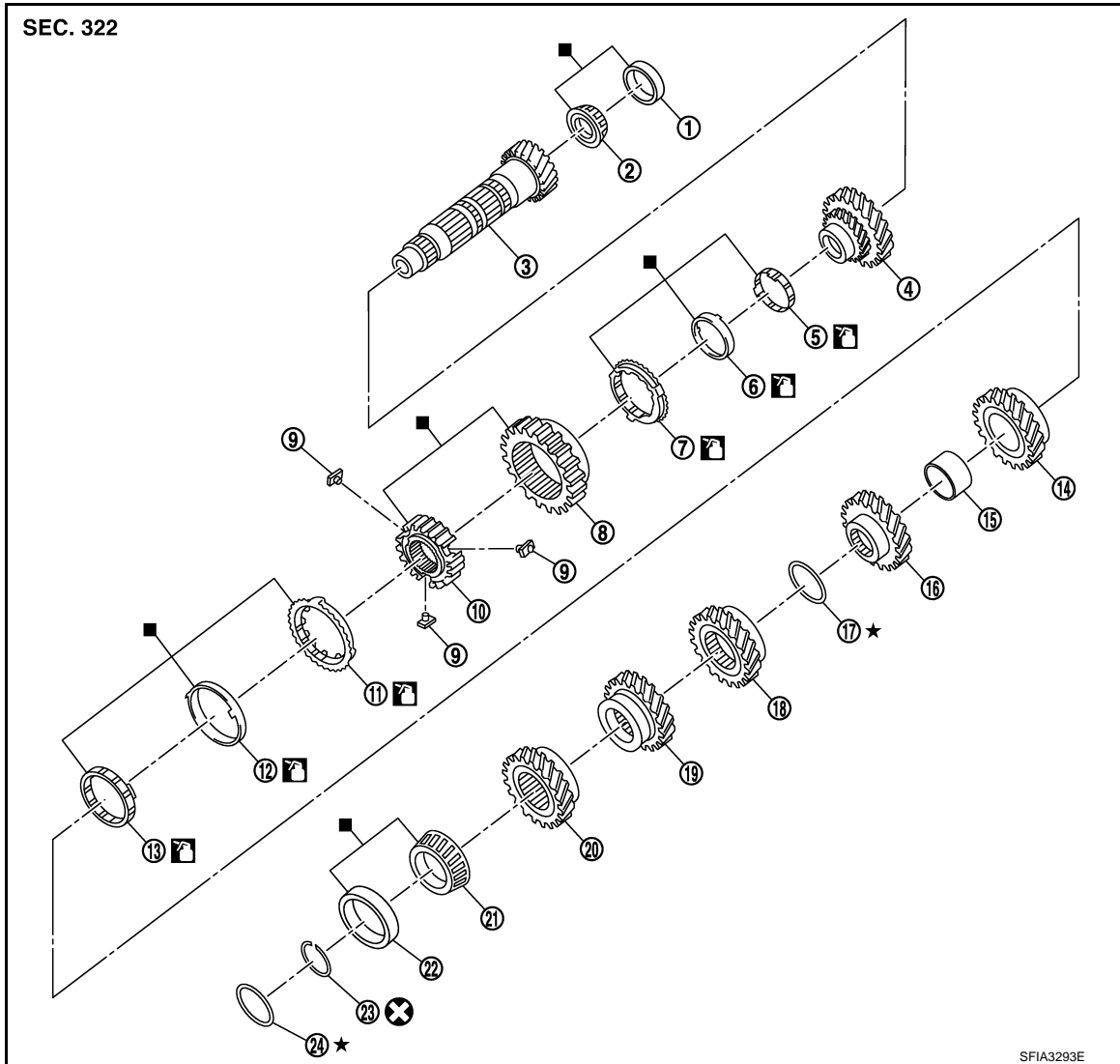

- |                                       |                                       |   |
|---------------------------------------|---------------------------------------|---|
| 1. Mainshaft front bearing outer race | 2. Mainshaft front bearing inner race | 3. Mainshaft                              |
| 4. 1st main gear                      | 5. 1st inner baulk ring               | 6. 1st synchronizer cone                  |
| 7. 1st outer baulk ring               | 8. 1st-2nd coupling sleeve            | 9. Insert key                             |
| 10. 1st-2nd synchronizer hub          | 11. 2nd outer baulk ring              | 12. 2nd synchronizer cone                 |
| 13. 2nd inner baulk ring              | 14. 2nd main gear                     | 15. Bushing                               |
| 16. 3rd main gear                     | 17. Mainshaft adjusting shim          | 18. 4th main gear                         |
| 19. 5th main gear                     | 20. 6th main gear                     | 21. Mainshaft rear bearing inner race     |
| 22. Mainshaft rear bearing outer race | 23. Snap ring                         | 24. Mainshaft rear bearing adjusting shim |

 : Apply gear oil.

 : Replace the parts as a set.

★ : Select with proper thickness.

 : Always replace after every disassembly.

SFIA3293E

A  
B  
C  
TM  
E  
F  
G  
H  
I  
J  
K  
L  
M  
N  
O  
P

# MAINSHAFT AND GEAR

< UNIT DISASSEMBLY AND ASSEMBLY >

[6MT: RS6F94R]

## Disassembly

INFOID:00000009752476

### CAUTION:

- Fix mainshaft in a vise with back plate, and then remove gears and snap rings.
- For removal of snap ring, set snap ring pliers and flat pliers at both sides of snap ring. While expanding snap ring with snap ring pliers, move snap ring with flat pliers.
- Disassemble gear components putting direction marks on the parts that never affect any functions.

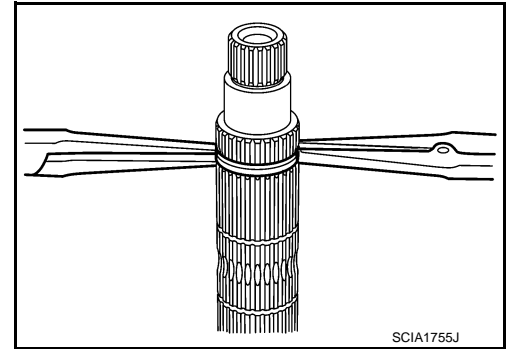

1. Remove snap ring (1).

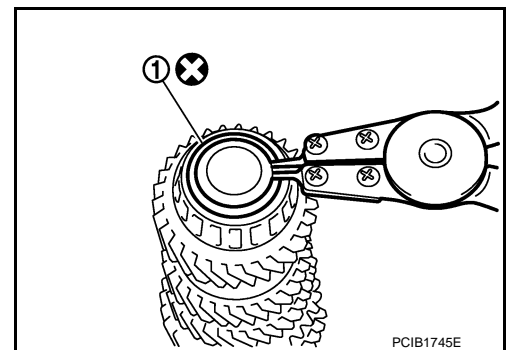

2. Remove 6th main gear (1) and mainshaft rear bearing inner race (2), as per the following procedure.
  - a. Set a puller [Commercial service tool] to 6th main gear.
  - b. Remove mainshaft rear bearing inner race and 6th main gear, using the drift (A) [SST: ST33052000 (-)].

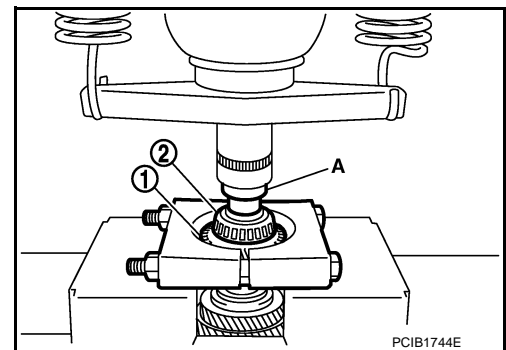

3. Remove 4th main gear (1) and 5th main gear (2), as per the following procedure.
  - a. Set a puller [Commercial service tool] to 4th main gear.
  - b. Remove 5th main gear and 4th main gear, using the drift (A) [SST: ST33052000 (-)].
4. Remove mainshaft adjusting shim.

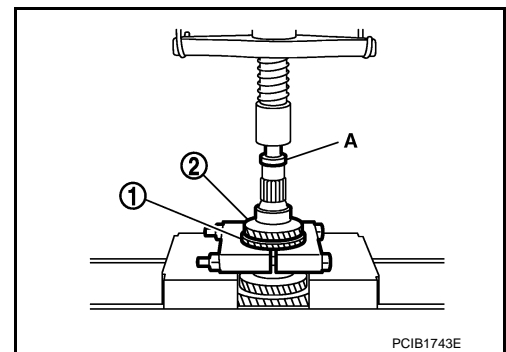

# MAINSHAFT AND GEAR

< UNIT DISASSEMBLY AND ASSEMBLY >

[6MT: RS6F94R]

5. Remove 1st main gear (1), 1st-2nd synchronizer hub assembly (2), 2nd main gear (3), and 3rd main gear (4), as per the following procedure.
  - a. Set a puller [Commercial service tool] to 1st main gear.
  - b. Remove 3rd main gear, busing, 2nd main gear, 2nd inner baulk ring, 2nd synchronizer cone, 2nd outer baulk ring, 1st-2nd synchronizer hub assembly, 1st outer baulk ring, 1st synchronizer cone, 1st inner baulk ring, and 1st main gear, using the drift (A) [SST: ST33052000 ( - )].
  - c. Remove insert keys and 1st-2nd coupling sleeve from 1st-2nd synchronizer hub.
6. Remove mainshaft front bearing inner race (1), as per the following procedure.
  - a. Set a puller [Commercial service tool] to mainshaft front bearing inner race.
  - b. Remove mainshaft front bearing inner race, using the drift (A) [SST: ST33052000 ( - )].

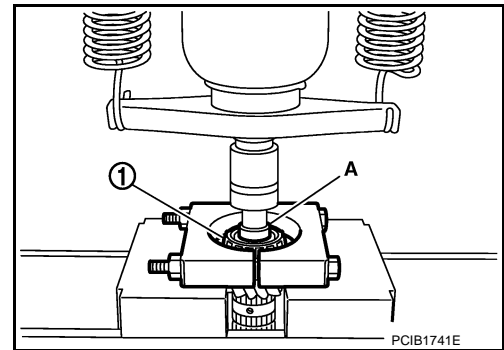
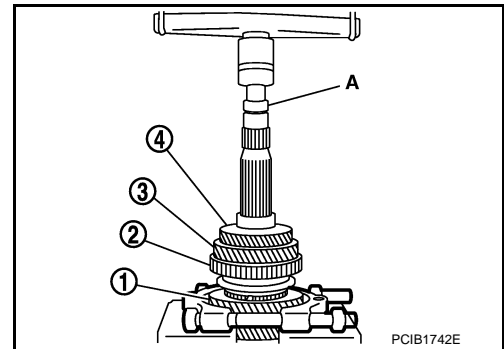

## Assembly

INFOID:000000009752477

### CAUTION:

- Select mainshaft rear bearing adjusting shim, as per the following procedure when replacing mainshaft adjusting shim, 6th main gear, 5th main gear, or 4th main gear.
  - Replace mainshaft adjusting shim.
  - If new mainshaft adjusting shim is thinner than previous one, offset the thickness difference by selecting thicker mainshaft rear bearing adjusting shim.
  - If new mainshaft adjusting shim is thicker than previous one, offset the thickness difference by selecting thinner mainshaft rear bearing adjusting shim.
  - Replace 6th main gear, 5th main gear, or 4th main gear.
  - Measure the thickness of the main gear used before and the new main gear
  - Increase the thickness of the mainshaft rear bearing adjusting shim, if the difference is smaller than 0.025 mm (0.0010 in).
  - Replace transaxle assembly when replacing mainshaft.
  - For installation of snap ring, set snap ring pliers and flat pliers at both sides of snap ring. While expanding snap ring with snap ring pliers, move snap ring with flat pliers.

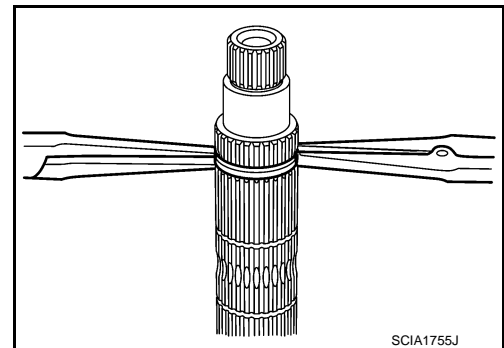

A  
B  
C  
TM  
E  
F  
G  
H  
I  
J  
K  
L  
M  
N  
O  
P

# MAINSHAFT AND GEAR

< UNIT DISASSEMBLY AND ASSEMBLY >

[6MT: RS6F94R]

1. Install mainshaft front bearing inner race (1), using the drift (A) [SST: ST36720030 ( - )].

**CAUTION:**

**Replace mainshaft front bearing outer race and mainshaft front bearing inner race as a set.**

2. Apply gear oil to 1st inner baulk ring, 1st synchronizer cone, 1st outer baulk ring, 2nd inner baulk ring, 2nd synchronizer cone, and 2nd outer baulk ring.

**CAUTION:**

- **Replace 1st inner baulk ring, 1st synchronizer cone, and 1st outer baulk ring as a set.**
- **Replace 2nd inner baulk ring, 2nd synchronizer cone, and 2nd outer baulk ring as a set.**

3. Install insert keys and 1st-2nd coupling sleeve to 1st-2nd synchronizer hub.

**CAUTION:**

**Replace 1st-2nd synchronizer hub and 1st-2nd coupling sleeve as a set.**

4. Install 1st main gear (1), 1st inner baulk ring, 1st synchronizer cone, 1st outer baulk ring, 1st-2nd synchronizer hub assembly (2), 2nd inner baulk ring, 2nd synchronizer cone, and 2nd outer baulk ring.

5. Install bushing (3), using the drift (A) [SST: KV32102700 ( - )].

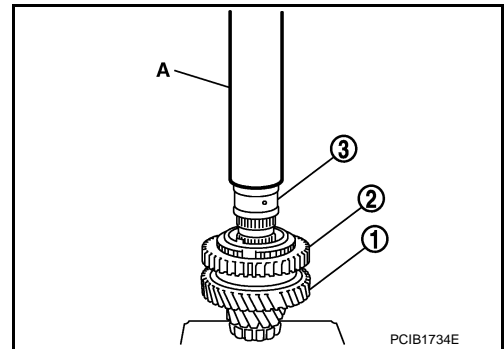
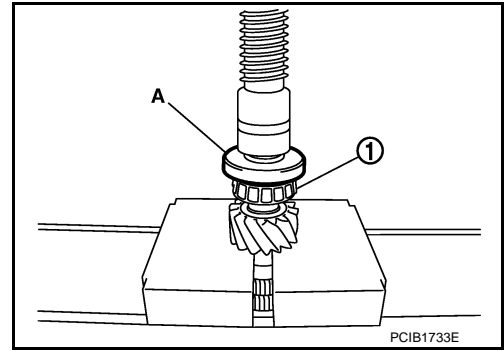

6. Install 3rd main gear (1) and 2nd main gear (2), using the drift (A) [SST: KV32102700 ( - )].

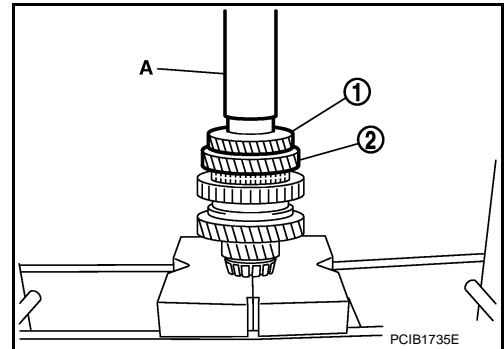

7. Measure dimension "L" as shown in the figure. Select mainshaft adjusting shim (1) according to the following list, and then install it to mainshaft.

- 2 : Mainshaft
- 3 : 3rd main gear

Unit: mm (in)

Dimension "L"	Mainshaft adjusting shim thickness
147.690 – 147.666 (5.8146 – 5.8136)	1.500 (0.0591)
147.665 – 147.641 (5.8136 – 5.8126)	1.525 (0.0600)
147.640 – 147.616 (5.8126 – 5.8116)	1.550 (0.0610)
147.615 – 147.591 (5.8116 – 5.8107)	1.575 (0.0620)
147.590 – 147.566 (5.8106 – 5.8097)	1.600 (0.0630)
147.565 – 147.541 (5.8096 – 5.8087)	1.625 (0.0640)
147.540 – 147.516 (5.8086 – 5.8077)	1.650 (0.0650)
147.515 – 147.491 (5.8077 – 5.8067)	1.675 (0.0659)

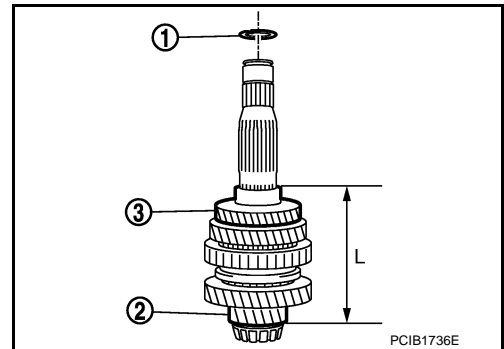

# MAINSHAFT AND GEAR

< UNIT DISASSEMBLY AND ASSEMBLY >

[6MT: RS6F94R]

Dimension "L"	Mainshaft adjusting shim thickness
147.490 – 147.466 (5.8067 – 5.8057)	1.700 (0.0669)
147.465 – 147.441 (5.8057 – 5.8048)	1.725 (0.0679)
147.440 – 147.416 (5.8047 – 5.8038)	1.750 (0.0689)
147.415 – 147.391 (5.8037 – 5.8028)	1.775 (0.0699)

8. Install 4th main gear (1), using the drift (A) [SST: KV32102700 (-)].

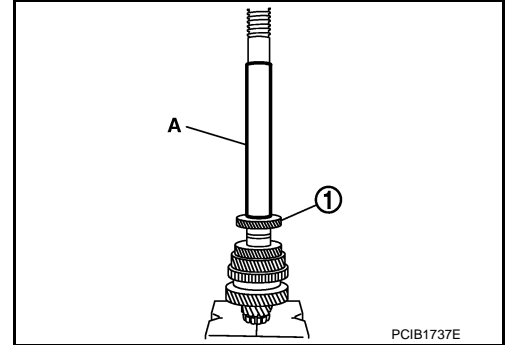

9. Install 5th main gear (1), using the drift (A) [SST: KV32102700 (-)].

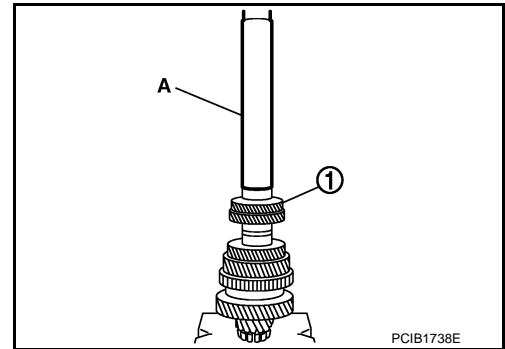

10. Install 6th main gear (1), using the drift (A) [SST: KV32102700 (-)].

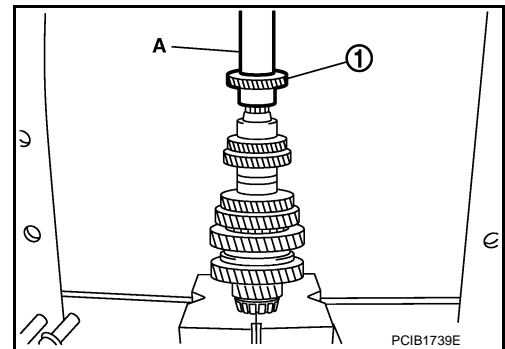

11. Install mainshaft rear bearing inner race (1), using the drift (A) [SST: ST30901000 (J-26010-01)].

**CAUTION:**

**Replace mainshaft rear bearing inner race and mainshaft rear bearing outer race as a set.**

12. Install snap ring.

**CAUTION:**

**Never reuse snap ring.**

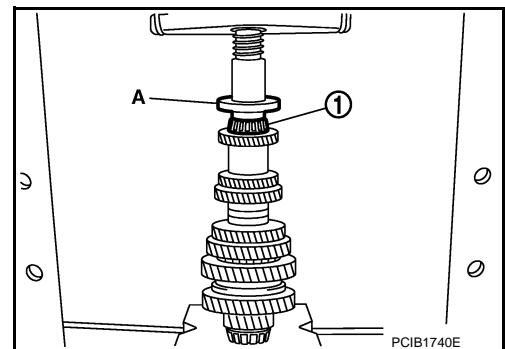

## Inspection

INFOID:000000009752478

## INSPECTION AFTER DISASSEMBLY

Mainshaft and Gear

A  
B  
C  
TM  
E  
F  
G  
H  
I  
J  
K  
L  
M  
N  
O  
P

# MAINSHAFT AND GEAR

< UNIT DISASSEMBLY AND ASSEMBLY >

[6MT: RS6F94R]

Check the following items and replace if necessary.

- Damage, peeling, bend, uneven wear, and distortion of shaft.
- Excessive wear, damage, and peeling of gear.

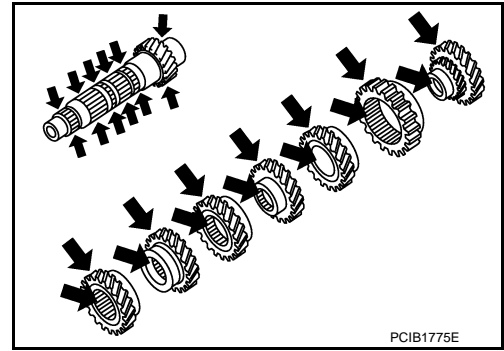

## Synchronizer Hub and Coupling Sleeve

Check the following items and replace if necessary.

- Breakage, damage, and unusual wear on contact surface of coupling sleeve, synchronizer hub, and insert key.
- Coupling sleeve and synchronizer hub move smoothly.

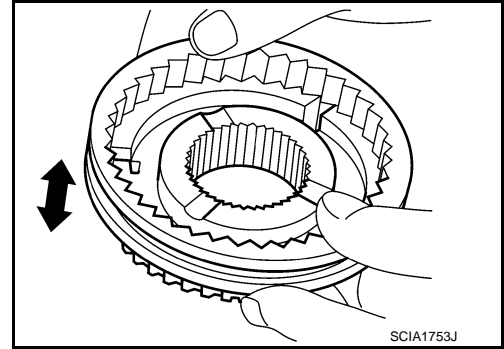

## Baulk Ring

Check contact surface of baulk ring cam and insert key for excessive wear, uneven wear, bend, and damage. Replace if necessary.

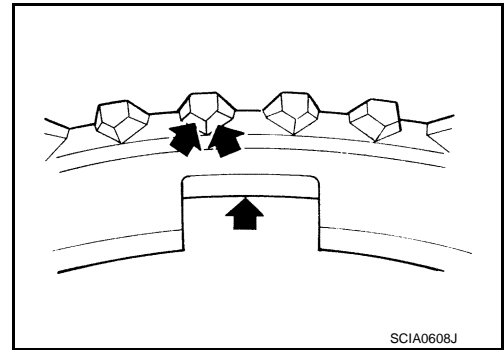

## Bearing

Check bearing for damage and unsmooth rotation. Replace if necessary.

### CAUTION:

- Replace mainshaft front bearing outer race and mainshaft front bearing inner race as a set.
- Replace mainshaft rear bearing inner race and mainshaft rear bearing outer race as a set.

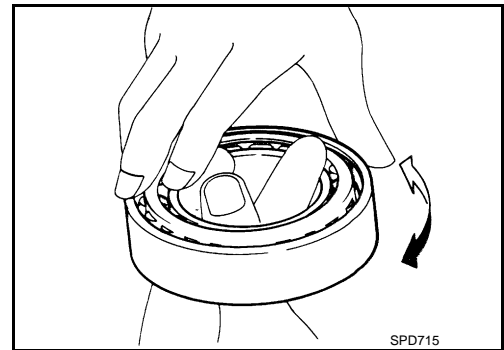



# REVERSE IDLER SHAFT AND GEAR

< UNIT DISASSEMBLY AND ASSEMBLY >

[6MT: RS6F94R]

## REVERSE IDLER SHAFT AND GEAR

Exploded View

INFOID:000000009752479

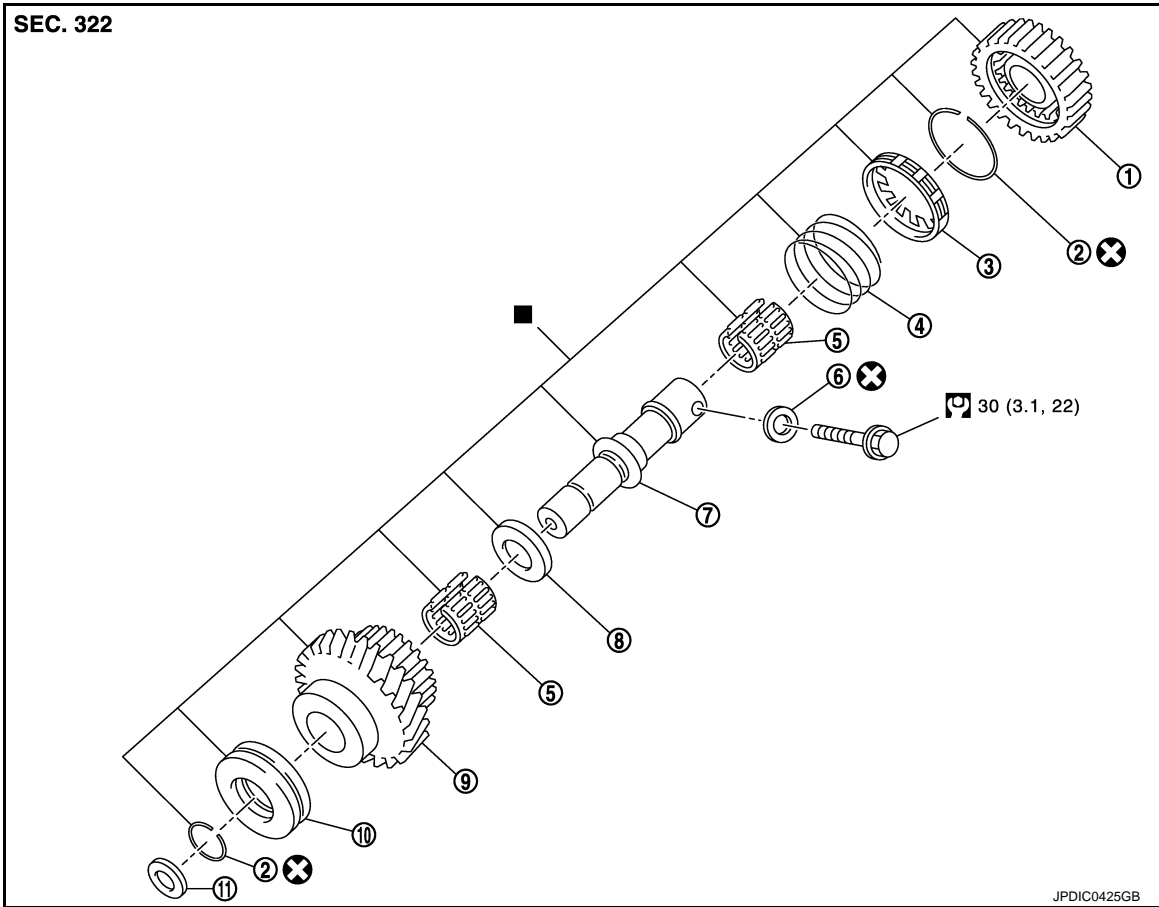

- |                        |                   |                       |
|------------------------|-------------------|-----------------------|
| 1. Reverse output gear | 2. Snap ring      | 3. Reverse baulk ring |
| 4. Return spring       | 5. Needle bearing | 6. Seal washer        |
| 7. Reverse idler shaft | 8. Spacer         | 9. Reverse input gear |
| 10. Lock washer        | 11. Spring washer |                       |

■ : Replace the parts as a set.

⊗ : Always replace after every disassembly.

Ⓜ : N·m (kg-m, ft-lb)

### Disassembly

INFOID:000000009752480

1. Remove reverse output gear (1).

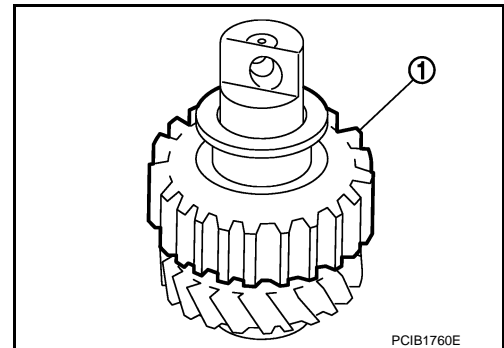

# REVERSE IDLER SHAFT AND GEAR

< UNIT DISASSEMBLY AND ASSEMBLY >

[6MT: RS6F94R]

2. Remove snap ring (1).

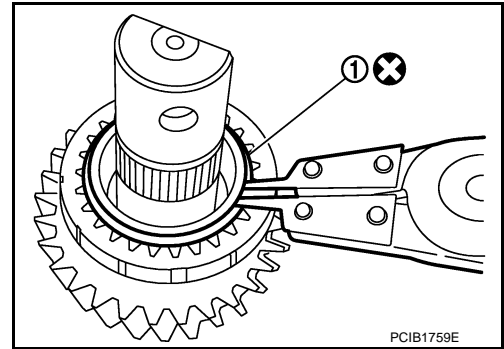

3. Remove reverse baulk ring (1) and return spring (2).

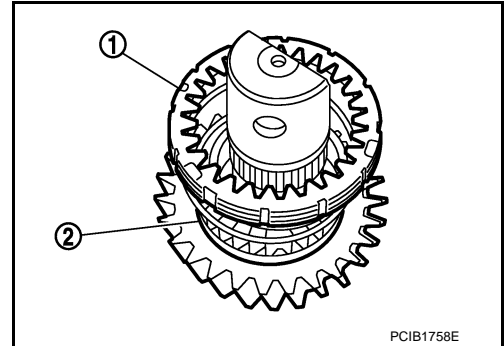

4. Remove snap ring (1), lock washer (2), and reverse input gear (3).

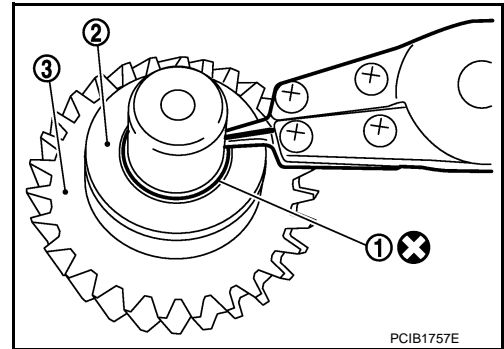

5. Remove needle bearings (1) and washer.

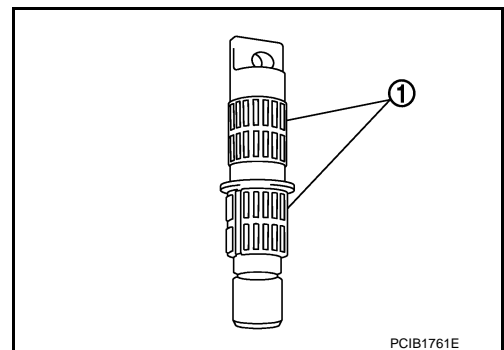

## Assembly

INFOID:000000009752481

Note the following procedures, and assemble in the reverse order of disassembly.

### CAUTION:

- Never reuse snap ring.
- Check that snap ring is securely installed in a groove.
- Replace reverse output gear, snap ring, reverse baulk ring, return spring, needle bearing, reverse idler shaft, spacer, reverse input gear, and lock washer as a set.

## Inspection

INFOID:000000009752482

## INSPECTION AFTER DISASSEMBLY

# REVERSE IDLER SHAFT AND GEAR

< UNIT DISASSEMBLY AND ASSEMBLY >

[6MT: RS6F94R]

## Shaft and Gear

Check the following items. Replace reverse output gear, snap ring, reverse baulk ring, return spring, needle bearing, reverse idler shaft, spacer, reverse input gear, and lock washer as a set, if necessary.

- Damage, peeling, bend, uneven wear, and distortion of shaft
- Excessive wear, damage, and peeling of gear

## Bearing

Check damage and rotation of bearing. Replace reverse output gear, snap ring, reverse baulk ring, return spring, needle bearing, reverse idler shaft, spacer, reverse input gear, and lock washer as a set, if necessary.

A

B

C

TM

E

F

G

H

I

J

K

L

M

N

O

P

# FINAL DRIVE

< UNIT DISASSEMBLY AND ASSEMBLY >

[6MT: RS6F94R]

## FINAL DRIVE

### Exploded View

INFOID:000000009752483

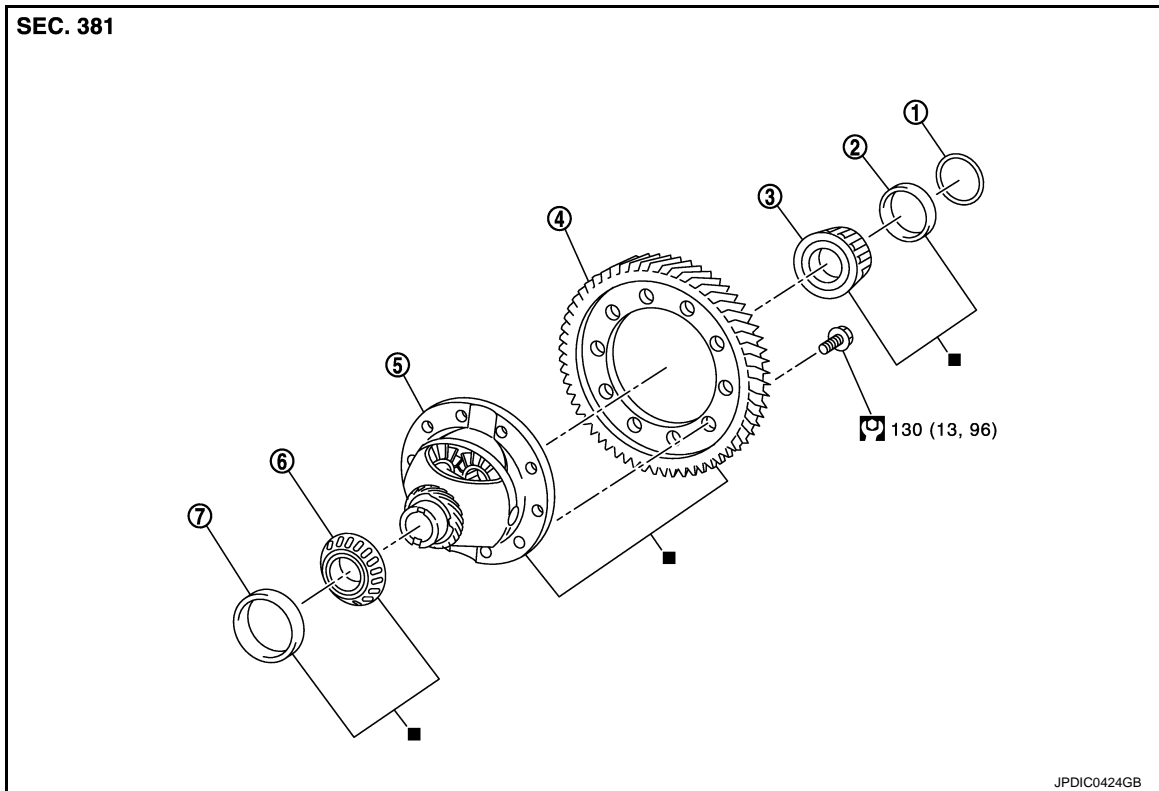

- |   |   |   |
|---|---|---|
| 1. Shim   | 2. Differential side bearing outer race (transaxle case side) | 3. Differential side bearing inner race (transaxle case side) |
| 4. Final gear   | 5. Differential case  | 6. Differential side bearing inner race (clutch housing side) |
| 7. Differential side bearing outer race (clutch housing side) |   |   |

■ : Replace the parts as a set.

☞ : N·m (kg-m, ft-lb)

### Disassembly

INFOID:000000009752484

1. Remove differential side bearing inner race (clutch housing side) (1), as per the following procedure.
  - a. Set a puller [Commercial service tool] to differential side bearing inner race (clutch housing side).
  - b. Remove differential side bearing inner race (clutch housing side), using the drift (A) [SST: ST33061000 (J-8107-2)].

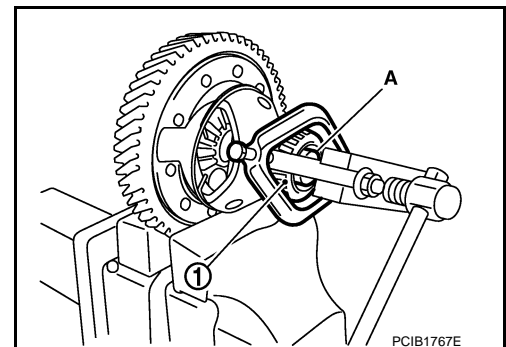

# FINAL DRIVE

## < UNIT DISASSEMBLY AND ASSEMBLY >

[6MT: RS6F94R]

- Remove final gear mounting bolts, and then remove final gear (1).

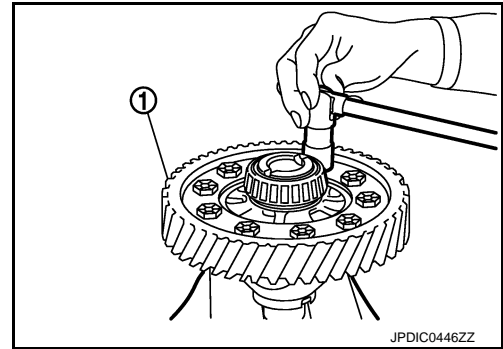

- Remove differential side bearing inner race (transaxle case side) (1), as per the following procedure.
  - Set a puller [Commercial service tool] to differential side bearing inner race (transaxle case side).
  - Remove differential side bearing inner race (transaxle case side), using a drift (A) [Commercial service tool].

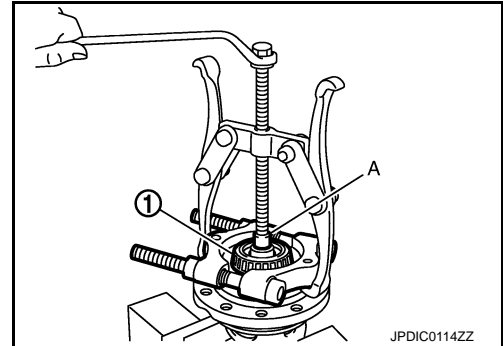

## Assembly

INFOID:000000009752485

- Install final gear, and then tighten final gear mounting bolts to the specified torque.

**CAUTION:**

**Replace final gear and differential case as a set.**

- Install differential side bearing inner race (clutch housing side), using a drift (A) [Commercial service tool].

**CAUTION:**

**Replace differential side bearing inner race (clutch housing side) and differential side bearing outer race (clutch housing side) as a set.**

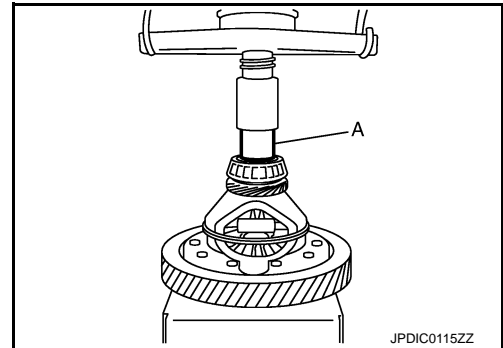

- Install differential side bearing inner race (transaxle case side), using a drift (A) [Commercial service tool].

**CAUTION:**

**Replace differential side bearing inner race (transaxle case side) and differential side bearing outer race (transaxle case side) as a set.**

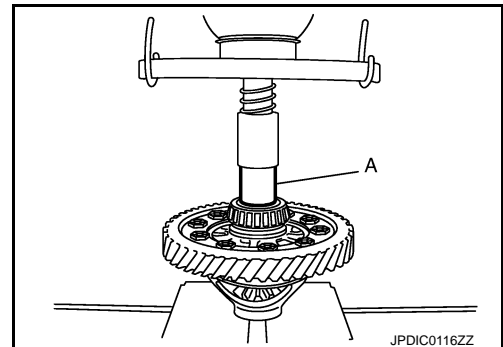

## Inspection

INFOID:000000009752486

### INSPECTION AFTER DISASSEMBLY

#### Gear and Case

Check final gear and differential case. Replace if necessary.

## FINAL DRIVE

< UNIT DISASSEMBLY AND ASSEMBLY >

[6MT: RS6F94R]

### Bearing

Check bearing for damage and unsmooth rotation. Replace if necessary.

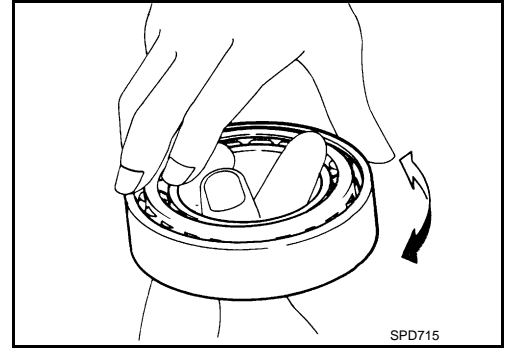

# SERVICE DATA AND SPECIFICATIONS (SDS)

< SERVICE DATA AND SPECIFICATIONS (SDS)

[6MT: RS6F94R]

## SERVICE DATA AND SPECIFICATIONS (SDS)

### SERVICE DATA AND SPECIFICATIONS (SDS)

#### General Specifications

INFOID:000000009752487

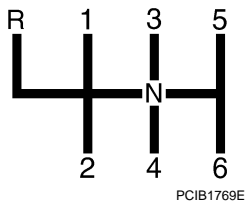
Transaxle type		RS6F94R	
Engine type		MR16DDT	
Axle type		2WD	
Number of speed		6	
Synchromesh type		Warner	
Shift pattern			
Gear ratio	1st	3.3636	
	2nd	1.9474	
	3rd	1.3929	
	4th	1.1143	
	5th	0.9143	
	6th	0.7674	
	Reverse	3.2915	
	Final gear	4.2143	
Number of teeth	Input gear	1st	11
		2nd	19
		3rd	28
		4th	35
		5th	35
		6th	43
		Reverse	11
	Main gear	1st	37
		2nd	37
		3rd	39
		4th	39
		5th	32
		6th	33
		Reverse	42
	Reverse idler gear	Input/Output	25/29
Final gear	Final gear/Pinion	59/14	
	Side gear/Pinion mate gear	13/10	
Oil capacity (Reference)		$\ell$ (US pt, Imp pt)	Approx. 2.0 (4-1/4, 3-1/2)
Remarks	Reverse synchronizer	Installed	
	Triple-cone synchronizer	1st and 2nd	

A  
B  
C  
TM  
E  
F  
G  
H  
I  
J  
K  
L  
M  
N  
O  
P

## PRECAUTION

### PRECAUTIONS

#### Precaution for Supplemental Restraint System (SRS) "AIR BAG" and "SEAT BELT PRE-TENSIONER"

INFOID:000000010282687

The Supplemental Restraint System such as "AIR BAG" and "SEAT BELT PRE-TENSIONER", used along with a front seat belt, helps to reduce the risk or severity of injury to the driver and front passenger for certain types of collision. This system includes seat belt switch inputs and dual stage front air bag modules. The SRS system uses the seat belt switches to determine the front air bag deployment, and may only deploy one front air bag, depending on the severity of a collision and whether the front occupants are belted or unbelted. Information necessary to service the system safely is included in the "SRS AIR BAG" and "SEAT BELT" of this Service Manual.

**WARNING:**

Always observe the following items for preventing accidental activation.

- To avoid rendering the SRS inoperative, which could increase the risk of personal injury or death in the event of a collision that would result in air bag inflation, all maintenance must be performed by an authorized NISSAN/INFINITI dealer.
- Improper maintenance, including incorrect removal and installation of the SRS, can lead to personal injury caused by unintentional activation of the system. For removal of Spiral Cable and Air Bag Module, see "SRS AIR BAG".
- Never use electrical test equipment on any circuit related to the SRS unless instructed to in this Service Manual. SRS wiring harnesses can be identified by yellow and/or orange harnesses or harness connectors.

#### PRECAUTIONS WHEN USING POWER TOOLS (AIR OR ELECTRIC) AND HAMMERS

**WARNING:**

Always observe the following items for preventing accidental activation.

- When working near the Air Bag Diagnosis Sensor Unit or other Air Bag System sensors with the ignition ON or engine running, never use air or electric power tools or strike near the sensor(s) with a hammer. Heavy vibration could activate the sensor(s) and deploy the air bag(s), possibly causing serious injury.
- When using air or electric power tools or hammers, always switch the ignition OFF, disconnect the battery, and wait at least 3 minutes before performing any service.

#### Precaution Necessary for Steering Wheel Rotation After Battery Disconnect

INFOID:000000010281884

**NOTE:**

- This Procedure is applied only to models with Intelligent Key system and NATS (NISSAN ANTI-THEFT SYSTEM).
- Remove and install all control units after disconnecting both battery cables with the ignition knob in the "LOCK" position.
- Always use CONSULT-III to perform self-diagnosis as a part of each function inspection after finishing work. If DTC is detected, perform trouble diagnosis according to self-diagnostic results.

For models equipped with the Intelligent Key system and NATS, an electrically controlled steering lock mechanism is adopted on the key cylinder.

For this reason, if the battery is disconnected or if the battery is discharged, the steering wheel will lock and steering wheel rotation will become impossible.

If steering wheel rotation is required when battery power is interrupted, follow the procedure below before starting the repair operation.

#### OPERATION PROCEDURE

1. Connect both battery cables.

**NOTE:**

Supply power using jumper cables if battery is discharged.

2. Use the Intelligent Key or mechanical key to turn the ignition switch to the "ACC" position. At this time, the steering lock will be released.
3. Disconnect both battery cables. The steering lock will remain released and the steering wheel can be rotated.



# PRECAUTIONS

[6MT: RS6F52H]

## < PRECAUTION >

4. Perform the necessary repair operation.
5. When the repair work is completed, return the ignition switch to the "LOCK" position before connecting the battery cables. (At this time, the steering lock mechanism will engage.)
6. Perform a self-diagnosis check of all control units using CONSULT-III.

## Precaution for Work

INFOID:000000010281885

- When removing or disassembling each component, be careful not to damage or deform it. If a component may be subject to interference, be sure to protect it with a shop cloth.
- When removing (disengaging) components with a screwdriver or similar tool, be sure to wrap the component with a shop cloth or vinyl tape to protect it.
- Protect the removed parts with a shop cloth and prevent them from being dropped.
- Replace a deformed or damaged clip.
- If a part is specified as a non-reusable part, always replace it with new one.
- Be sure to tighten bolts and nuts securely to the specified torque.
- After installation is complete, be sure to check that each part works properly.
- Follow the steps below to clean components.
  - Water soluble dirt: Dip a soft cloth into lukewarm water, and wring the water out of the cloth to wipe the dirty area.  
Then rub with a soft and dry cloth.
  - Oily dirt: Dip a soft cloth into lukewarm water with mild detergent (concentration: within 2 to 3%), and wipe the dirty area.  
Then dip a cloth into fresh water, and wring the water out of the cloth to wipe the detergent off. Then rub with a soft and dry cloth.
- Do not use organic solvent such as thinner, benzene, alcohol, or gasoline.
- For genuine leather seats, use a genuine leather seat cleaner.

## Service Notice or Precaution

INFOID:000000010281886

- Do not reuse transaxle oil, once it has been drained.
- Check oil level or replace oil with vehicle on level surface.
- During removal or installation, keep inside of transaxle clear of dust or dirt.
- Check for the correct installation status prior to removal or disassembly. If matching marks are required, be certain they do not interfere with the function of the parts they are applied.
- In principle, tighten bolts or nuts gradually in several steps working diagonally from inside to outside. If tightening sequence is specified, use it.
- Be careful not to damage sliding surfaces and mating surfaces.

## Precautions for Removing of Battery Terminal

INFOID:000000010282683

- When removing the 12V battery terminal, turn OFF the ignition switch and wait at least 30 seconds.

### NOTE:

ECU may be active for several tens of seconds after the ignition switch is turned OFF. If the battery terminal is removed before ECU stops, then a DTC detection error or ECU data corruption may occur.

- For vehicles with the 2-batteries, be sure to connect the main battery and the sub battery before turning ON the ignition switch.

### NOTE:

If the ignition switch is turned ON with any one of the terminals of main battery and sub battery disconnected, then DTC may be detected.

- After installing the 12V battery, always check "Self Diagnosis Result" of all ECUs and erase DTC.

### NOTE:

The removal of 12V battery may cause a DTC detection error.

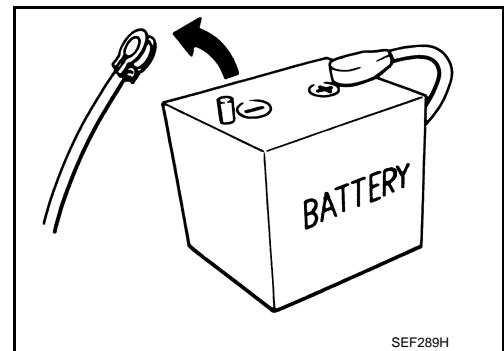

# PREPARATION

< PREPARATION >

[6MT: RS6F52H]

## PREPARATION

### PREPARATION

#### Special Service Tool

INFOID:000000010281887

The actual shapes of Kent-Moore tools may differ from those of special service tools illustrated here.

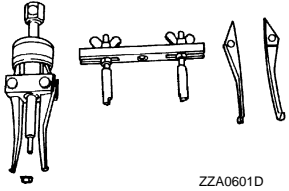
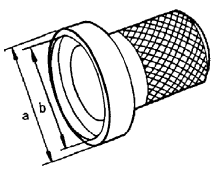
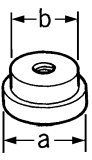
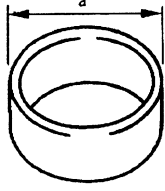
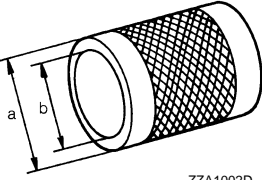
Tool number (Kent-Moore No.) Tool name	Description
KV381054S0 (J-34286) Puller  ZZA0601D	<ul style="list-style-type: none"> <li>• Removing differential side bearing outer race (clutch housing side)</li> <li>• Removing differential side bearing outer race (transaxle case side)</li> <li>• Removing mainshaft front bearing</li> </ul>
ST33400001 (J-26082) Drift  ZZA0814D	Installing differential side oil seal (clutch housing side) <b>a: 60 mm (2.36 in) dia.</b> <b>b: 47 mm (1.85 in) dia.</b>
ST35321000 ( — ) Drift  ZZA1000D	<ul style="list-style-type: none"> <li>• Installing input shaft oil seal</li> <li>• Installing reverse main gear</li> <li>• Installing 1st main gear bushing</li> <li>• Installing 1st-2nd synchronizer hub assembly</li> <li>• Installing 2nd main gear bushing</li> <li>• Installing 3rd main gear</li> </ul> <b>a: 49 mm (1.93 in) dia.</b> <b>b: 41 mm (1.61 in) dia.</b>
KV40105320 ( — ) Drift  ZZA0898D	Installing differential side bearing outer race (clutch housing side) <b>a: 88 mm (3.46 in) dia.</b>
ST33200000 (J-26082) Drift  ZZA1002D	<ul style="list-style-type: none"> <li>• Installing mainshaft front bearing</li> <li>• Installing 6th input gear bushing</li> <li>• Installing 4th main gear</li> <li>• Installing 5th main gear</li> <li>• Installing 6th main gear</li> </ul> <b>a: 60 mm (2.36 in) dia.</b> <b>b: 44.5 mm (1.752 in) dia.</b>

# PREPARATION

< PREPARATION >

[6MT: RS6F52H]

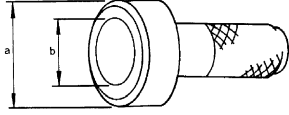
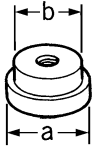
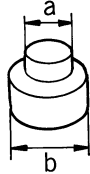
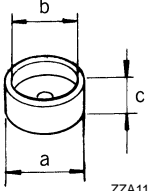
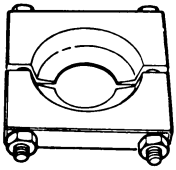
Tool number (Kent-Moore No.) Tool name	Description	
ST30720000 (J-25405) Drift   ZZA0811D	<ul style="list-style-type: none"> <li>• Installing differential side oil seal (transaxle case side)</li> <li>• Installing differential side bearing outer race (clutch housing side)</li> <li>• Installing differential side bearing outer race (transaxle case side)</li> <li>• Installing mainshaft rear bearing</li> <li>• Installing differential side bearing (clutch housing side)</li> <li>• Installing differential side bearing (transaxle case side)</li> </ul> <p><b>a: 77 mm (3.03 in) dia.</b> <b>b: 55.5 mm (2.185 in) dia.</b></p>	A B C TM
ST33061000 (J-8107-2) Drift   ZZA1000D	<ul style="list-style-type: none"> <li>• Installing bore plug</li> <li>• Removing differential side bearing (transaxle case side)</li> <li>• Removing differential side bearing (clutch housing side)</li> </ul> <p><b>a: 38 mm (1.50 in) dia.</b> <b>b: 28.5 mm (1.122 in) dia.</b></p>	E F G
ST33052000 ( — ) Drift   ZZA1023D	<ul style="list-style-type: none"> <li>• Removing input shaft rear bearing</li> <li>• Removing 6th input gear, 6th input gear bushing, 5th-6th synchronizer hub assembly, and 5th input gear</li> <li>• Removing 5th input gear bushing, 4th input gear, 4th input gear bushing, 3rd-4th synchronizer hub assembly, and 3rd input gear</li> <li>• Installing input shaft front bearing</li> <li>• Removing mainshaft rear bearing</li> <li>• Removing 6th main gear</li> <li>• Removing 4th main gear and 5th main gear</li> </ul> <p><b>a: 22 mm (0.87 in) dia.</b> <b>b: 28 mm (1.10 in) dia.</b></p>	H I J
KV40105020 ( — ) Drift   ZZA1133D	Removing 3rd main gear, 2nd main gear, 2nd main gear bushing, 1st-2nd synchronizer hub assembly, 1st main gear, 1st main gear bushing, and reverse main gear  <p><b>a: 39.7 mm (1.563 in) dia.</b> <b>b: 35 mm (1.38 in) dia.</b> <b>c: 15 mm (0.59 in)</b></p>	K L M
ST30031000 (J-22912-01) Puller   ZZA0537D	Measuring wear of inner baulk ring	N O P

# PREPARATION

< PREPARATION >

[6MT: RS6F52H]

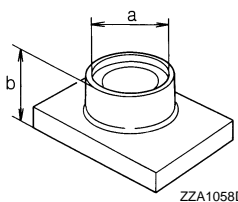
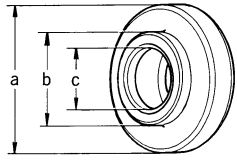
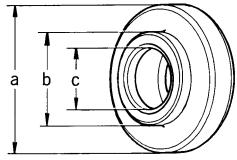
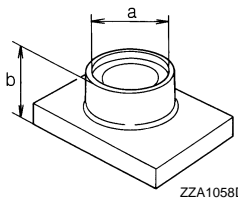
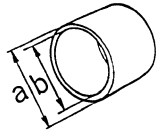
Tool number (Kent-Moore No.) Tool name	Description
KV40105710 ( — ) Press stand  ZZA1058D	<ul style="list-style-type: none"> <li>• Installing 3rd-4th synchronizer hub assembly</li> <li>• Installing 4th input gear bushing</li> <li>• Installing 5th input gear bushing</li> <li>• Installing 5th-6th synchronizer hub assembly</li> <li>• Installing 2nd main gear bushing</li> <li>• Installing 3rd main gear</li> </ul> <p><b>a: 46 mm (1.81 in) dia.</b>  <b>b: 41 mm (1.61 in)</b></p>
ST30901000 (J-26010-01) Drift  ZZA0978D	<ul style="list-style-type: none"> <li>• Installing input shaft rear bearing</li> <li>• Installing 4th main gear</li> <li>• Installing 5th main gear</li> <li>• Installing 6th main gear</li> <li>• Installing mainshaft rear bearing</li> </ul> <p><b>a: 79 mm (3.11 in) dia.</b>  <b>b: 45 mm (1.77 in) dia.</b>  <b>c: 35.2 mm (1.386 in) dia.</b></p>
ST30032000 (J-26010-01) Drift  ZZA0978D	Installing input shaft front bearing <p><b>a: 80 mm (3.15 in) dia.</b>  <b>b: 38 mm (1.50 in) dia.</b>  <b>c: 31 mm (1.22 in) dia.</b></p>
ST38220000 ( — ) Press stand  ZZA1058D	<ul style="list-style-type: none"> <li>• Installing reverse main gear</li> <li>• Installing 1st main gear bushing</li> <li>• Installing 1st-2nd synchronizer hub assembly</li> </ul> <p><b>a: 63 mm (2.48 in) dia.</b>  <b>b: 65 mm (2.56 in)</b></p>
KV40101630 (J-35870) Drift  ZZA1003D	Installing reverse main gear <p><b>a: 68 mm (2.68 in) dia.</b>  <b>b: 60 mm (2.36 in) dia.</b></p>

# PREPARATION

< PREPARATION >

[6MT: RS6F52H]

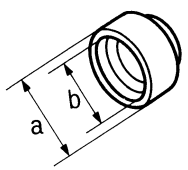
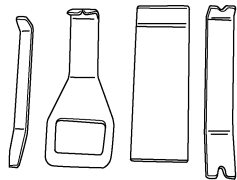
Tool number (Kent-Moore No.) Tool name	Description	
KV38102510 (   —   ) Drift	 <p style="text-align: center; font-size: small;">ZZA0838D</p> <ul style="list-style-type: none"> <li>Installing 1st main gear bushing</li> <li>Installing 1st-2nd synchronizer hub assembly</li> <li>Installing differential side bearing (transaxle case side)</li> <li>Installing differential side bearing (clutch housing side)</li> </ul> <p><b>a: 71 mm (2.80 in) dia.</b>  <b>b: 65 mm (2.56 in) dia.</b></p>	A  B  C
— ( J-46534 ) Trim tool set	 <p style="text-align: center; font-size: small;">AWJIA0483ZZ</p> <p>For removing trim</p>	TM  E  F

## Commercial Service Tool

INFOID:0000000010281888

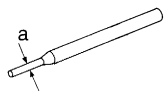
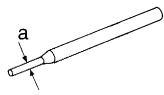
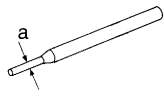
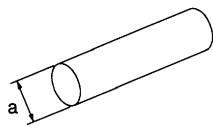
Tool name	Description	
Pin punch	 <p style="text-align: center; font-size: x-small;">NT410</p> <p>Removing and installing retaining pin  <b>a: 4.5 mm (0.177 in) dia.</b></p>	G  H  I  J
Pin punch	 <p style="text-align: center; font-size: x-small;">NT410</p> <p>Removing and installing retaining pin of selector lever  <b>a: 5.5 mm (0.217 in) dia.</b></p>	K  L
Pin punch	 <p style="text-align: center; font-size: x-small;">NT410</p> <p>Removing and installing retaining pin of each shifter lever  <b>a: 7.5 mm (0.295 in) dia.</b></p>	M  N
Drift	 <p style="text-align: center; font-size: x-small;">S-NT063</p> <p>Installing striking rod oil seal and shifter lever oil seal  <b>a: 24.5 mm (0.965 in) dia.</b></p>	O  P

# PREPARATION

< PREPARATION >

[6MT: RS6F52H]

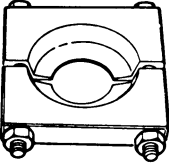
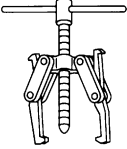
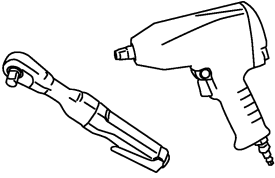
Tool name	Description
<p>Puller</p>  <p>ZZA0537D</p>	<p>Removing each bearing, gear, and bushing</p>
<p>Puller</p>  <p>NT077</p>	<p>Removing each bearing, gear, and bushing</p>
<p>Power tool</p>  <p>PBIC0190E</p>	<p>Loosening bolts and nuts</p>

## SYSTEM DESCRIPTION

### STRUCTURE AND OPERATION

#### Sectional View

INFOID:0000000010281890

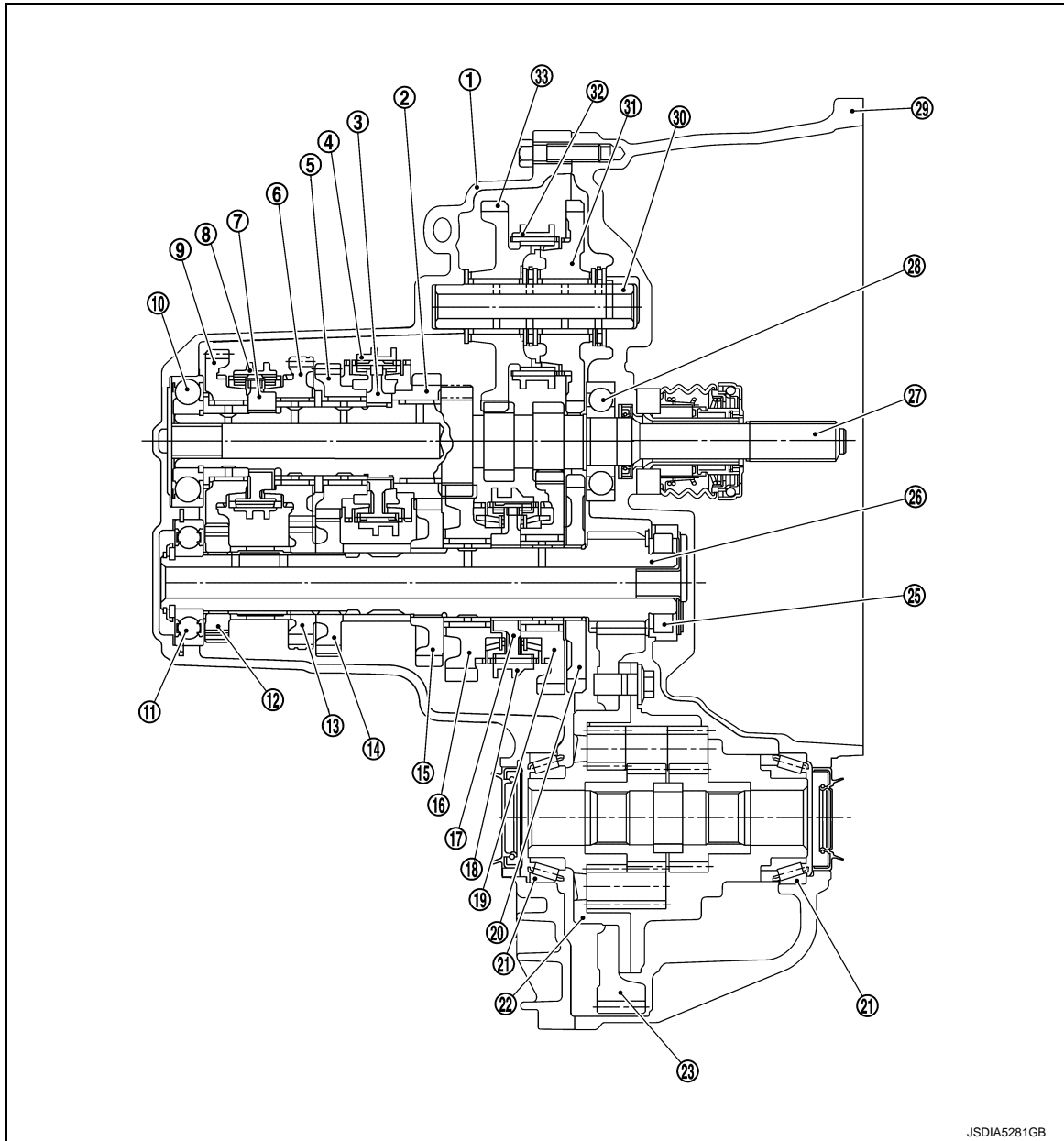

- |                                |                              |                                |
|--------------------------------|------------------------------|--------------------------------|
| 1. Transaxle case              | 2. 3rd input gear            | 3. 3rd-4th synchronizer hub    |
| 4. 3rd-4th coupling sleeve     | 5. 4th input gear            | 6. 5th input gear              |
| 7. 5th-6th synchronizer hub    | 8. 5th-6th coupling sleeve   | 9. 6th input gear              |
| 10. Input shaft rear bearing   | 11. Mainshaft rear bearing   | 12. 6th main gear              |
| 13. 5th main gear              | 14. 4th main gear            | 15. 3rd main gear              |
| 16. 2nd main gear              | 17. 1st-2nd synchronizer hub | 18. 1st-2nd coupling sleeve    |
| 19. 1st main gear              | 20. Reverse main gear        | 21. Differential side bearing  |
| 22. Differential case assembly | 23. Final gear               | 24. Mainshaft front bearing    |
| 25. Mainshaft                  | 26. Input shaft              | 27. Input shaft front bearing  |
| 28. Clutch housing             | 29. Reverse idler shaft      | 30. Reverse idler gear (front) |
| 31. Reverse coupling sleeve    | 32. Reverse idler gear(rear) |                                |

A  
B  
C  
TM  
E  
F  
G  
H  
I  
J  
K  
L  
M  
N  
O  
P

# STRUCTURE AND OPERATION

< SYSTEM DESCRIPTION >

[6MT: RS6F52H]

## System Description

INFOID:000000010291433

### DOUBLE-CONE SYNCHRONIZER

Double-cone synchronizer is adopted for 3rd gear to reduce operating force of the control lever.

### TRIPLE-CONE SYNCHRONIZER

Triple-cone synchronizer are adopted for 1st and 2nd gears to reduce operating force of the control lever.

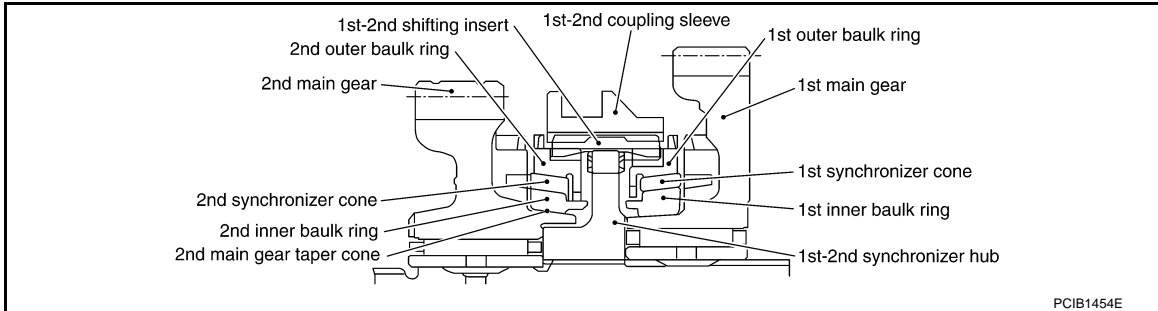

### REVERSE GEAR NOISE PREVENTION FUNCTION (SYNCHRONIZING METHOD)

Reverse gear can be matched smoothly in a structure by setting synchronizer hub (1) of reverse idler gear (rear), reverse coupling sleeve (2), reverse baulk ring (3), and reverse insert spring (4) to reverse idler gears, and letting reverse gear be synchronized.

- 5 : Reverse idler gear (rear)
- 6 : Reverse idler gear (front)

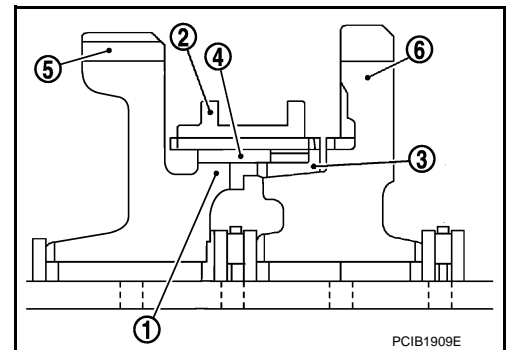



## DTC/CIRCUIT DIAGNOSIS

### POSITION SWITCH

#### BACK-UP LAMP SWITCH

#### BACK-UP LAMP SWITCH : Component Inspection

INFOID:000000010291111

#### 1. CHECK BACK-UP LAMP SWITCH

1. Disconnect position switch connector. Refer to [TM-77. "Removal and Installation"](#).
2. Check continuity between position switch terminals.

Gear position	Continuity
Reverse	Yes
Except reverse	No

- 1 : Park/Neutral position (PNP) switch  
2 : Back-up lamp switch

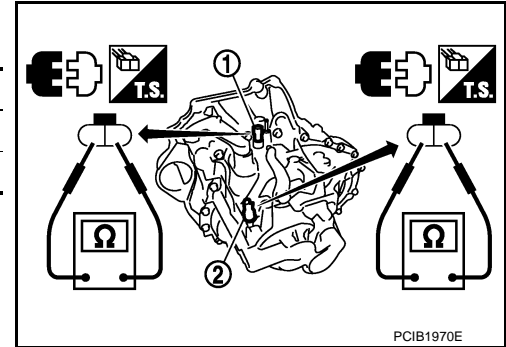

Is the inspection result normal?

YES >> INSPECTION END

NO >> Replace position switch. Refer to [TM-77. "Removal and Installation"](#).

#### PARK/NEUTRAL POSITION (PNP) SWITCH

#### PARK/NEUTRAL POSITION (PNP) SWITCH : Component Inspection

INFOID:000000010291112

#### 1. CHECK PARK/NEUTRAL POSITION (PNP) SWITCH

1. Disconnect position switch connector. Refer to [TM-20. "Removal and Installation"](#).
2. Check continuity between position switch terminals.

Gear position	Continuity
Neutral	Yes
Except neutral	No

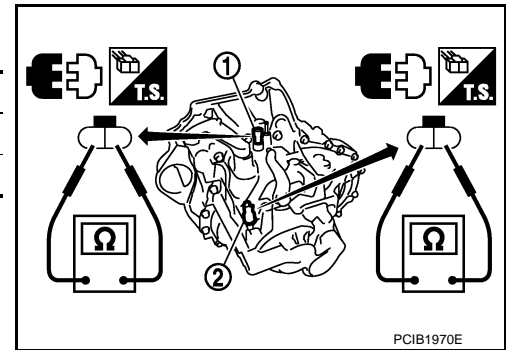

Is the inspection result normal?

YES >> INSPECTION END

NO >> Replace position switch.

A  
B  
C  
TM  
E  
F  
G  
H  
I  
J  
K  
L  
M  
N  
O  
P

# NOISE, VIBRATION AND HARSHNESS (NVH) TROUBLESHOOTING

< SYMPTOM DIAGNOSIS >

[6MT: RS6F52H]

## SYMPTOM DIAGNOSIS

### NOISE, VIBRATION AND HARSHNESS (NVH) TROUBLESHOOTING

#### NVH Troubleshooting Chart

INFOID:000000010281889

Use the chart below to help you find the cause of the symptom. The numbers indicate the order of the inspection. If necessary, repair or replace these parts.

	SUSPECTED PARTS (Possible cause)											
Reference page	OIL (Oil level is low.) OIL (Wrong oil.) OIL (Oil level is high.) GASKET (Damaged) OIL SEAL (Worn or damaged) SHIFT CONTROL LINKAGE (Worn) STRIKING ROD ASSEMBLY (Worn or damaged) SHIFT FORK (Worn) GEAR (Worn or damaged) BEARING (Worn or damaged) BAULK RING (Worn or damaged) INSERT SPRING (Damaged)	<a href="#">TM-75</a>		<a href="#">TM-83</a>		<a href="#">TM-78</a>		<a href="#">TM-120</a>		<a href="#">TM-83, TM-112, TM-120, TM-131, TM-131</a>		
Symptoms	Noise	1	2							3	3	
	Oil leakage		3	1	2	2						
	Hard to shift or will not shift		1	1			2					3
	Jumps out of gear						1	2	3	3		

PERIODIC MAINTENANCE

GEAR OIL

Inspection

INFOID:0000000010291397

OIL LEAKAGE

Make sure that gear oil is not leaking from transaxle or around it.

OIL LEVEL

1. Remove filler plug (1) and gasket from transaxle case.
2. Check the oil level from filler plug mounting hole as shown in the figure.  
**CAUTION:**  
**Never start engine while checking oil level.**
3. Set a gasket on filler plug and then install it to transaxle case.  
**CAUTION:**  
**Never reuse gasket.**
4. Tighten filler plug to the specified torque. Refer to [TM-83, "Exploded View"](#).

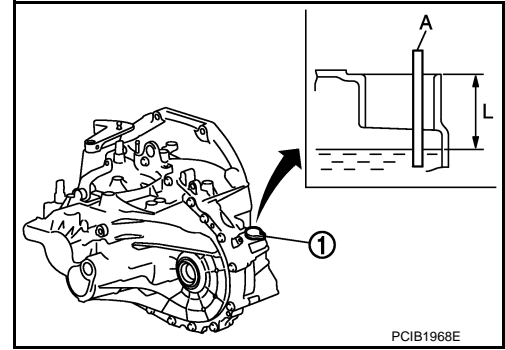

Draining

INFOID:0000000010291398

1. Start engine and let it run to warm up transaxle.
2. Stop engine. Remove drain plug (1) and gasket, using a socket [Commercial service tool] and then drain gear oil.
3. Set a gasket on drain plug and install it to clutch housing, using a socket [Commercial service tool].  
**CAUTION:**  
**Never reuse gasket.**
4. Tighten drain plug to the specified torque. Refer to [TM-81, "Exploded View"](#).

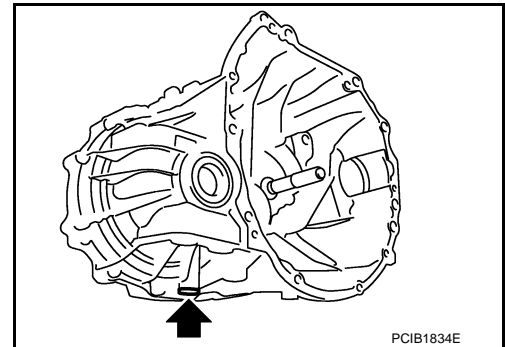

Refilling

INFOID:0000000010291399

Refilling

1. Remove plug (1). Fill the transaxle with new oil and check the oil level (L) using suitable gauge (A) as shown.

**Oil grade and capacity** : Refer to [TM-138, "General Specification"](#).

**Oil level (L)** : 38.5 - 45.5 mm (1.516 - 1.791 in)

2. Install a new O-ring onto plug (1) and then install it to transaxle. Tighten to the specified torque. Refer to [TM-83, "Exploded View"](#).

**CAUTION:**  
**Do not reuse O-ring.**

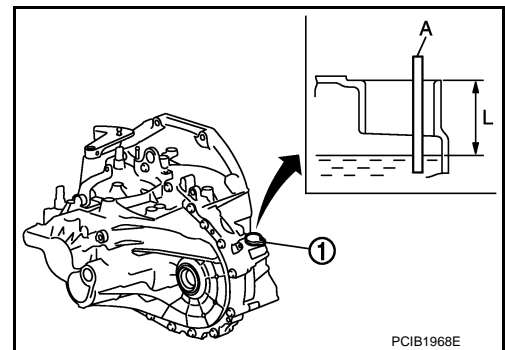

A  
B  
C  
TM  
E  
F  
G  
H  
I  
J  
K  
L  
M  
N  
O  
P

## REMOVAL AND INSTALLATION

### SIDE OIL SEAL

#### Removal and Installation

INFOID:000000010281893

#### REMOVAL

1. Remove front drive shafts from transaxle assembly. Refer to [FAX-20. "LEFT SIDE : Removal and Installation"](#) and [FAX-22. "RIGHT SIDE : Removal and Installation"](#).

2. Remove differential side oil seal (1) using a suitable tool.

**CAUTION:**

**Do not damage transaxle case and clutch housing.**

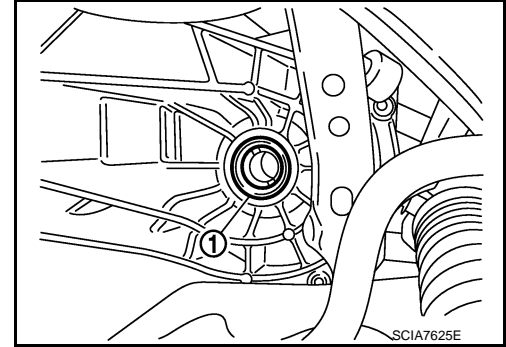

#### INSTALLATION

Installation is in the reverse order of removal.

- Install differential side oil seal to clutch housing and transaxle case to the specified dimension (A) using Tools.

**Dimension A) : -0.5 - 0.5 mm (-0.020 - 0.020 in)**

**Tool numbers : ST30720000 (J-25405)**

**: ST33400001 (J-26082)**

**CAUTION:**

**Do not reuse oil seal.**

- Check oil level after installation. Refer to [TM-75. "Inspection"](#).

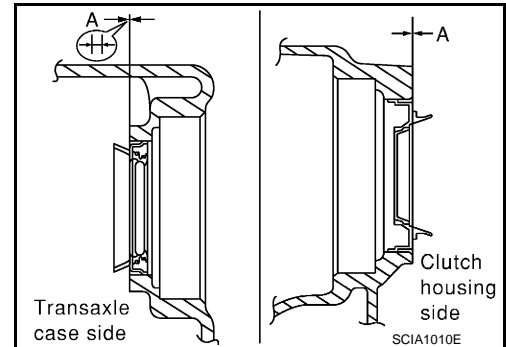

# POSITION SWITCH

< REMOVAL AND INSTALLATION >

[6MT: RS6F52H]

## POSITION SWITCH

### Removal and Installation

INFOID:000000010291221

#### REMOVAL

1. Remove battery. Refer to [PG-99, "Removal and Installation"](#).
2. Disconnect position switch connector.
3. Remove position switch from transaxle case.

#### INSTALLATION

1. Apply recommended sealant to threads of position switch.
  - Use Genuine Silicone RTV or an equivalent. Refer to [GI-24, "Recommended Chemical Products and Sealants"](#).

**CAUTION:**

**Remove old sealant and oil adhering to threads.**

2. Install position switch to transaxle case.
3. Tighten position switch to the specified torque. Refer to [TM-83, "Exploded View"](#).
4. For the next step and after, install in the reverse order of removal.

### Inspection

INFOID:000000010291379

#### INSPECTION AFTER INSTALLATION

- Check continuity between position switch terminals. Refer to [TM-73, "BACK-UP LAMP SWITCH : Component Inspection"](#) (Back-up lamp switch) and [TM-73, "PARK/NEUTRAL POSITION \(PNP\) SWITCH : Component Inspection"](#) (PNP switch).
- Check the oil leakage. Refer to [TM-75, "Inspection"](#).

A  
B  
C  
TM  
E  
F  
G  
H  
I  
J  
K  
L  
M  
N  
O  
P

# CONTROL LINKAGE

< REMOVAL AND INSTALLATION >

[6MT: RS6F52H]

## CONTROL LINKAGE

Exploded View

INFOID:000000010291434

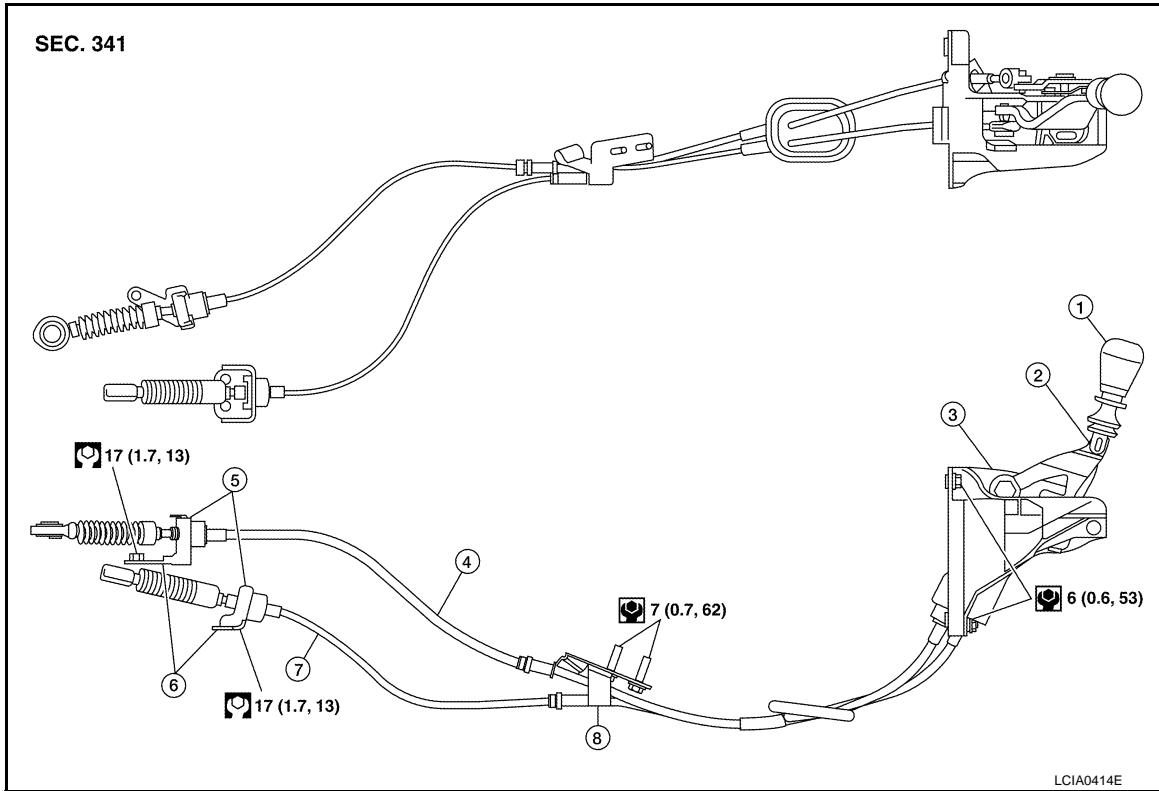

- |                        |                          |                            |
|------------------------|--------------------------|----------------------------|
| 1. Shift selector knob | 2. Shift selector        | 3. Shift selector assembly |
| 4. Select cable        | 5. Lock plate            | 6. Cable bracket           |
| 7. Shift cable         | 8. Cable support bracket |                            |

 : N·m (kg·m, ft·lb)

 : N·m (kg·m, in·lb)

## Removal and Installation

INFOID:000000010281896

### REMOVAL

1. Remove battery. Refer to [PG-99, "Removal and Installation"](#).
2. Remove air cleaner and air duct. Refer to [EM-25, "Removal and Installation"](#).
3. Remove shift cable from shifter lever as shown.

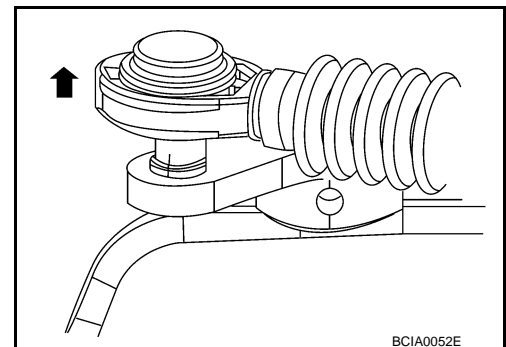

# CONTROL LINKAGE

## < REMOVAL AND INSTALLATION >

[6MT: RS6F52H]

4. Remove select cable from selector lever A as shown.

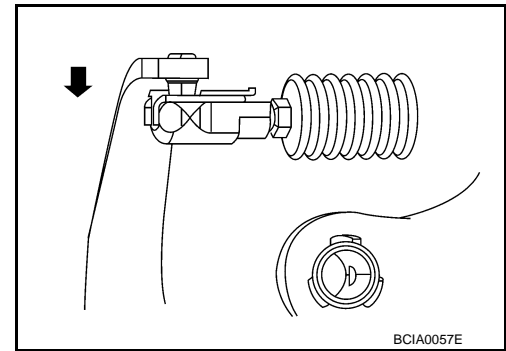

5. Move shift selector to neutral position.  
6. Remove shift selector knob.  
7. Remove center console assembly. Refer to [IP-24, "Removal and Installation"](#).  
8. Remove shift selector assembly nuts.  
9. Remove exhaust front tube, center muffler and heat shield. Refer to [EX-8, "Removal and Installation"](#).  
10. Remove cable support bracket.  
11. Remove select cable and shift cable from cable bracket.  
12. Remove shift selector assembly from the vehicle.

### INSTALLATION

Installation is in the reverse order of removal.

- Securely install each cable to shifter lever and selector lever.
- Be careful about the installation direction, and screw shift selector knob onto shift selector.

⇐: Front

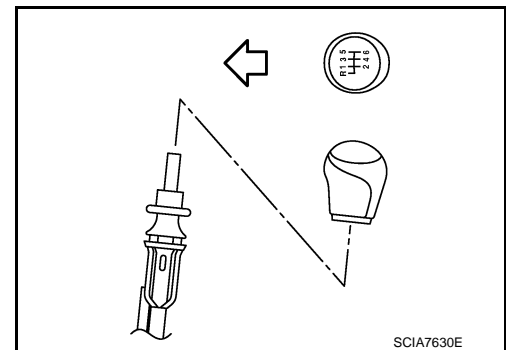

- When shift selector is selected to 1st-2nd side and 5th-6th side, confirm shift selector returns to neutral position smoothly.
- When shift selector is shifted to each position, make sure there is no binding or disconnection in each boot.

# AIR BREATHER HOSE

< REMOVAL AND INSTALLATION >

[6MT: RS6F52H]

## AIR BREATHER HOSE

Exploded View

INFOID:000000010291436

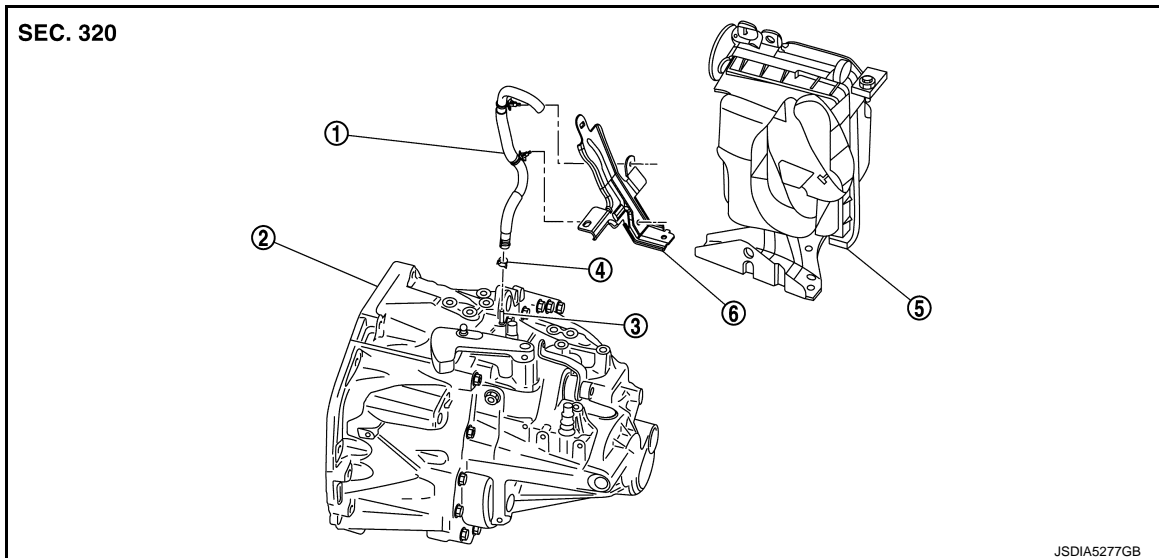

- |                      |                       |                      |
|----------------------|-----------------------|----------------------|
| 1. Air breather hose | 2. Transaxle assembly | 3. Air breather tube |
| 4. Clamp             | 5. Air cleaner case   | 6. Bracket           |

## Removal and Installation

INFOID:000000010281897

### REMOVAL

1. Disconnect air breather hose clip and disconnect air breather hose from the battery bracket.
2. Release air breather hose clamp and remove air breather hose.

### INSTALLATION

Installation is in the reverse order of removal.

#### **CAUTION:**

- Make sure there are no pinched or restricted areas on the air breather hose caused by bending or winding when installing it.
- Be sure to insert air breather hose into air breather tube until hose end reaches the tube's base.
- Set air breather hose with painted mark facing forward.
- Install air breather hose to air cleaner case by fully inserting the clip.



# TRANSAXLE ASSEMBLY

< UNIT REMOVAL AND INSTALLATION >

[6MT: RS6F52H]

## UNIT REMOVAL AND INSTALLATION

### TRANSAXLE ASSEMBLY

Exploded View

INFOID:0000000010281898

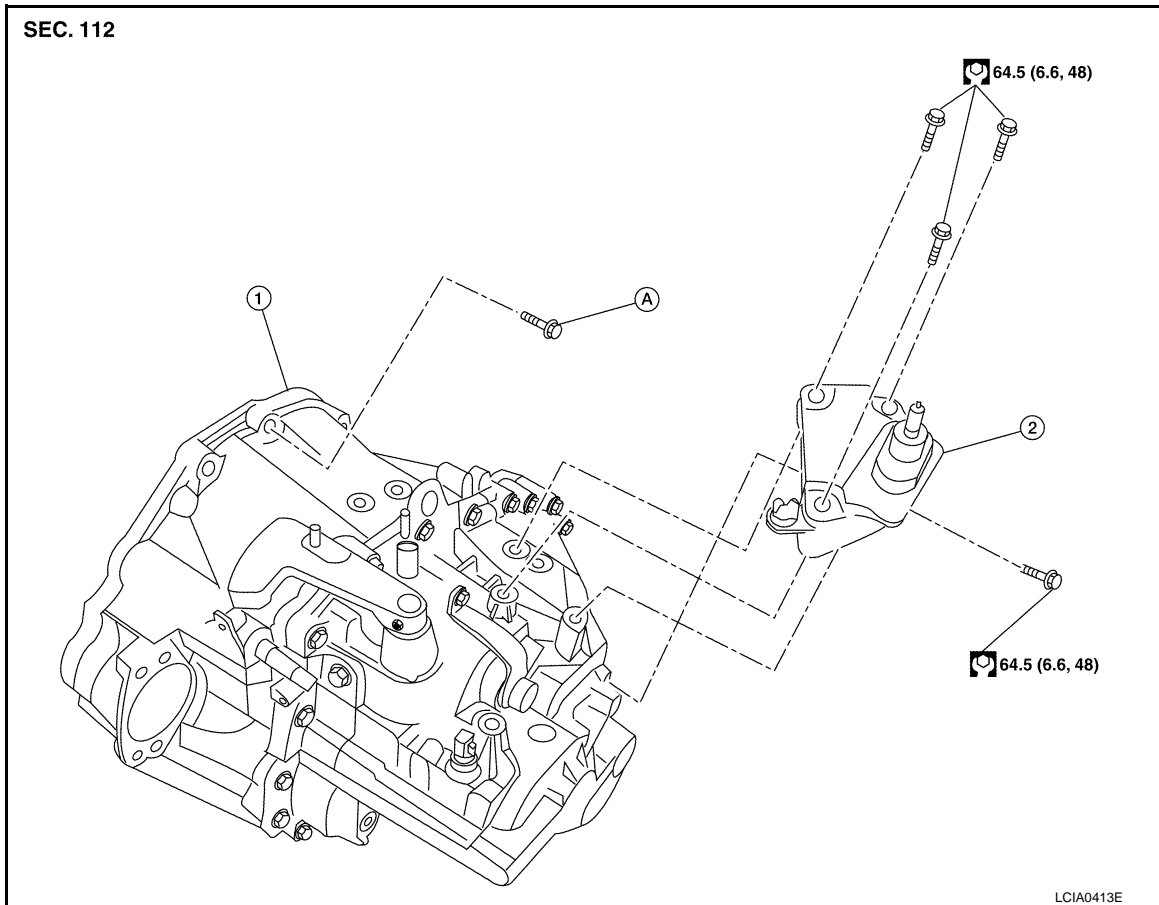

1. Transaxle assembly
2. LH engine mount bracket
- A. Refer to [TM-81, "Removal and Installation"](#).

### Removal and Installation

INFOID:0000000010281899

#### CAUTION:

If transaxle assembly is removed from the vehicle, always replace CSC (Concentric Slave Cylinder). Inserted CSC returns to the original position when removing transaxle assembly. Dust on clutch disc sliding parts may damage CSC seal, and may cause clutch fluid leakage.

#### REMOVAL

1. Remove clutch tube from CSC. Refer to [CL-17, "Removal and Installation"](#).

#### CAUTION:

Do not depress clutch pedal during removal procedure.

#### NOTE:

Cap or plug opening(s) to prevent fluid from spilling.

2. Remove engine and transaxle assembly. Refer to [EM-61, "2WD : Removal and Installation"](#).
3. Remove starter motor. Refer to [STR-37, "Removal and Installation"](#).
4. Remove transaxle assembly to engine bolts.
5. Separate transaxle assembly from engine.

#### INSTALLATION

Installation is in the reverse order of removal.

# TRANSAXLE ASSEMBLY

[6MT: RS6F52H]

## < UNIT REMOVAL AND INSTALLATION >

- If transaxle assembly is removed from the vehicle, always replace CSC. Refer to [CL-17, "Removal and Installation"](#).
- When installing the transaxle assembly to the engine, use the specified tightening torque in the numerical sequence shown:

- : Transaxle to engine
- ✕ : Engine to transaxle

**CAUTION:**

**When installing transaxle assembly, do not allow the transaxle input shaft to make contact with the clutch cover.**

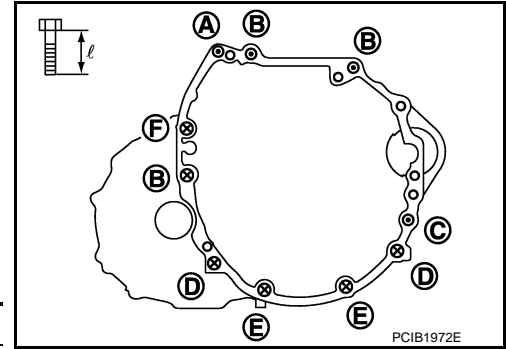

Bolt symbol	A	B	C	D	E	F
Quantity	1	3	1	2	2	1
Bolt length "ℓ" mm (in)	45 (1.77)		80 (3.15)	45 (1.77)	35 (1.38)	45 (1.77)
Tightening torque N·m (kg·m, ft·lb)	35.3 (3.6, 26)		74.5 (7.6, 55)		42.6 (4.3, 31)	
					48.0 (4.9, 35)	

- Bleed the air from the clutch hydraulic system. Refer to [CL-10, "Air Bleeding"](#).
- After installation, check oil level and check for leaks and loose mechanisms. Refer to [TM-75, "Inspection"](#).

# TRANSAXLE ASSEMBLY

< UNIT DISASSEMBLY AND ASSEMBLY >

[6MT: RS6F52H]

## UNIT DISASSEMBLY AND ASSEMBLY

### TRANSAXLE ASSEMBLY

Exploded View

INFOID:000000010291437

#### CASE AND HOUSING

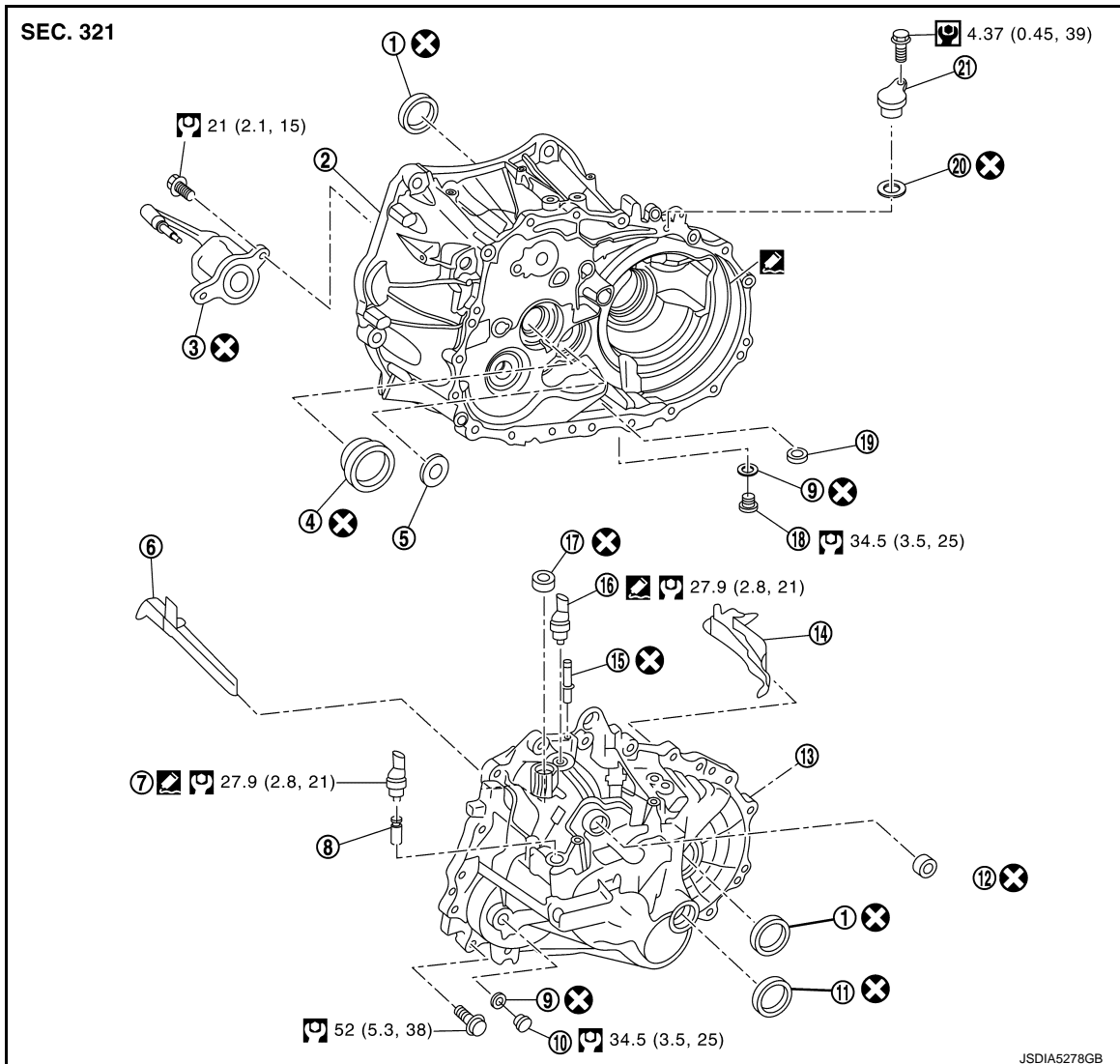

- |  |                            |                                    |
|--|----------------------------|------------------------------------|
| 1. Differential side oil seal          | 2. Clutch housing          | 3. CSC (Concentric Slave Cylinder) |
| 4. Input shaft oil seal                | 5. Oil channel             | 6. Oil gutter A                    |
| 7. Back-up lamp switch                 | 8. Plunger                 | 9. Gasket                          |
| 10. Plug                               | 11. Bore plug              | 12. Striking rod oil seal          |
| 13. Transaxle case                     | 14. Oil gutter B           | 15. Air breather tube              |
| 16. Park/Neutral position (PNP) switch | 17. Shifter lever oil seal | 18. Drain plug                     |
| 19. Magnet                             | 20. O-ring                 | 21. Plug                           |

: Apply Genuine Silicone RTV or an equivalent. Refer to [GI-24, "Recommended Chemical Products and Sealants"](#).

: Always replace after every disassembly.

: Select with proper thickness.

# TRANSAXLE ASSEMBLY

< UNIT DISASSEMBLY AND ASSEMBLY >

[6MT: RS6F52H]

 : N·m (kg-m, ft-lb)

 : N·m (kg-m, in-lb)

## SHAFT AND GEAR

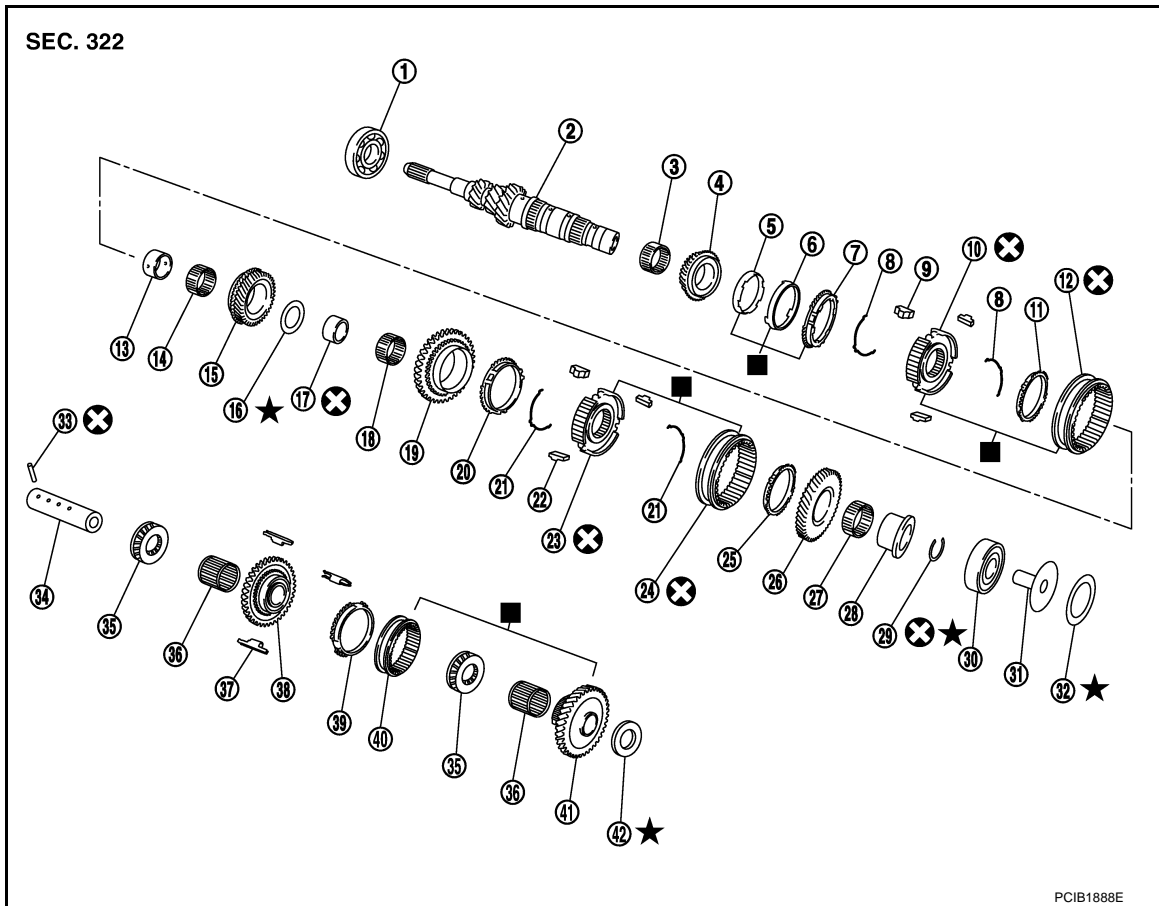



PCIB1888E

- |                              |   |                                       |
|------------------------------|---|---------------------------------------|
| 1. Input shaft front bearing | 2. Input shaft                              | 3. 3rd needle bearing                 |
| 4. 3rd input gear            | 5. 3rd inner baulk ring                     | 6. 3rd synchronizer cone              |
| 7. 3rd outer baulk ring      | 8. 3rd-4th spread spring                    | 9. 3rd-4th shifting insert            |
| 10. 3rd-4th synchronizer hub | 11. 4th baulk ring                          | 12. 3rd-4th coupling sleeve           |
| 13. 4th input gear bushing   | 14. 4th needle bearing                      | 15. 4th input gear                    |
| 16. Thrust washer            | 17. 5th input gear bushing                  | 18. 5th needle bearing                |
| 19. 5th input gear           | 20. 5th baulk ring                          | 21. 5th-6th spread spring             |
| 22. 5th-6th shifting insert  | 23. 5th-6th synchronizer hub                | 24. 5th-6th coupling sleeve           |
| 25. 6th baulk ring           | 26. 6th input gear                          | 27. 6th needle bearing                |
| 28. 6th input gear bushing   | 29. Snap ring                               | 30. Input shaft rear bearing          |
| 31. Oil channel              | 32. Input shaft rear bearing adjusting shim | 33. Retaining pin                     |
| 34. Reverse idler shaft      | 35. Thrust needle bearing                   | 36. Reverse idler gear needle bearing |
| 37. Reverse insert spring    | 38. Reverse idler gear (front)              | 39. Reverse baulk ring                |
| 40. Reverse coupling sleeve  | 41. Reverse idler gear (rear)               | 42. Reverse idler gear adjusting shim |

 : Apply gear oil.

 : Replace the parts as a set.

 : Always replace after every disassembly.

 : N·m (kg-m, ft-lb)

# TRANSAXLE ASSEMBLY

< UNIT DISASSEMBLY AND ASSEMBLY >

[6MT: RS6F52H]

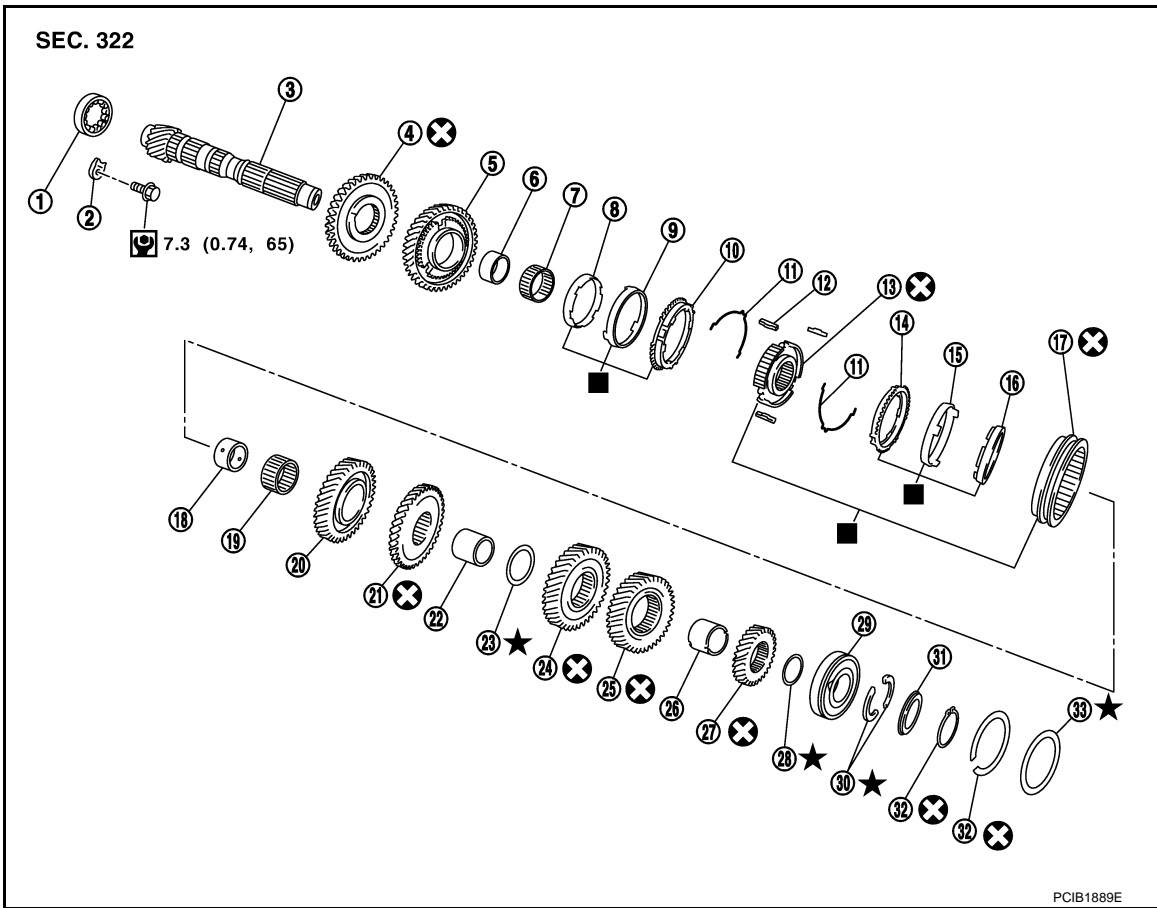

- |                                  |                                  |   |
|----------------------------------|----------------------------------|---|
| 1. Mainshaft front bearing       | 2. Mainshaft bearing retainer    | 3. Mainshaft                              |
| 4. Reverse main gear             | 5. 1st main gear                 | 6. 1st main gear bushing                  |
| 7. 1st needle bearing            | 8. 1st inner baulk ring          | 9. 1st synchronizer cone                  |
| 10. 1st outer baulk ring         | 11. 1st-2nd spread spring        | 12. 1st-2nd shifting insert               |
| 13. 1st-2nd synchronizer hub     | 14. 2nd outer baulk ring         | 15. 2nd synchronizer cone                 |
| 16. 2nd inner baulk ring         | 17. 1st-2nd coupling sleeve      | 18. 2nd main gear bushing                 |
| 19. 2nd needle bearing           | 20. 2nd main gear                | 21. 3rd main gear                         |
| 22. 3rd-4th mainshaft spacer     | 23. 4th main gear adjusting shim | 24. 4th main gear                         |
| 25. 5th main gear                | 26. 5th-6th mainshaft spacer     | 27. 6th main gear                         |
| 28. 6th main gear adjusting shim | 29. Mainshaft rear bearing       | 30. Mainshaft C-ring                      |
| 31. C-ring holder                | 32. Snap ring                    | 33. Mainshaft rear bearing adjusting shim |

: Apply gear oil.

: Replace the parts as a set.

: Always replace after every disassembly.

: N-m (kg-m, ft-lb)

## SHIFT FORK AND FORK ROD

A  
B  
C  
TM  
E  
F  
G  
H  
I  
J  
K  
L  
M  
N  
O  
P

# TRANSAXLE ASSEMBLY

< UNIT DISASSEMBLY AND ASSEMBLY >

[6MT: RS6F52H]

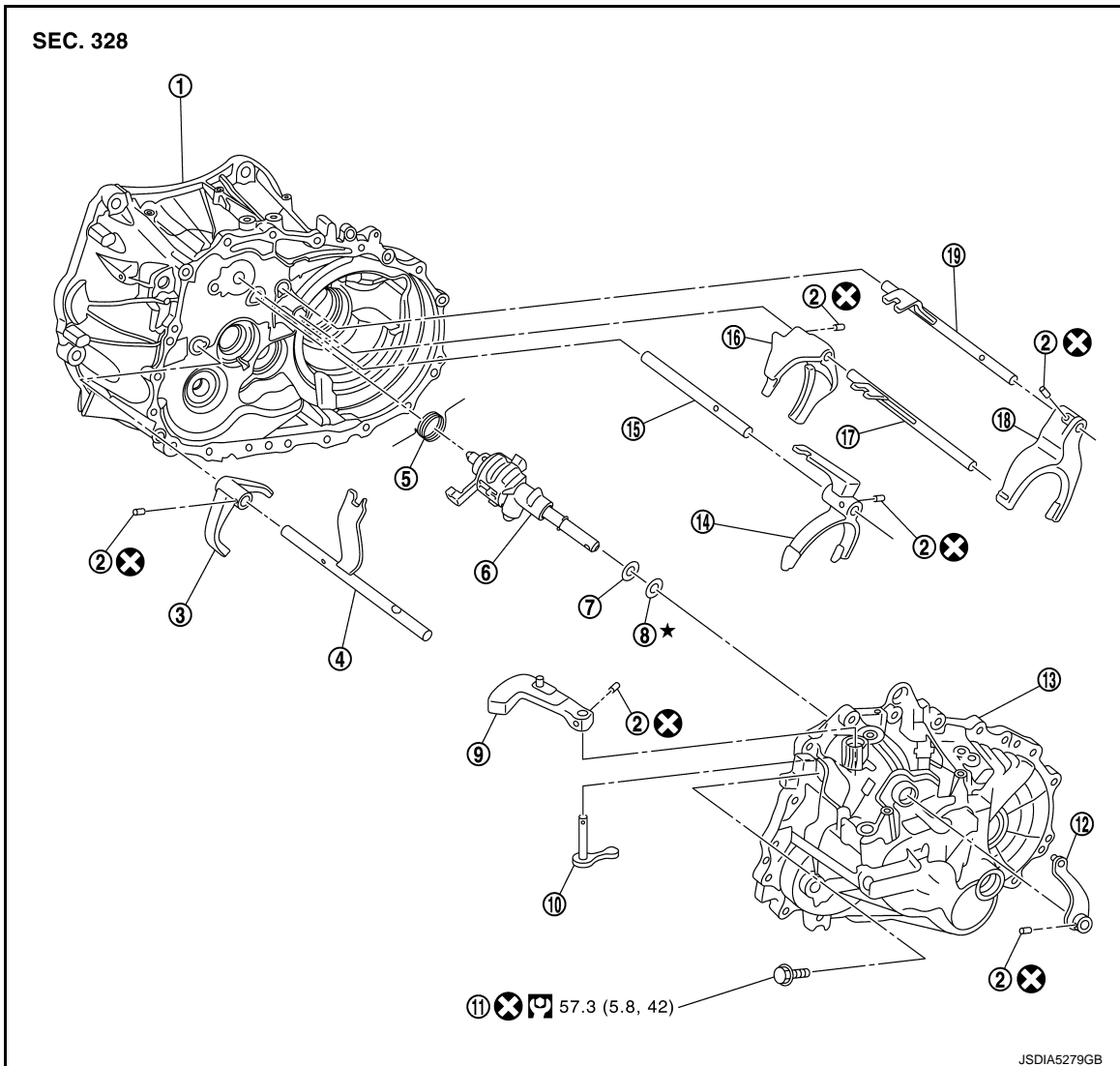

- |                        |                                |                          |
|------------------------|--------------------------------|--------------------------|
| 1. Clutch housing      | 2. Retaining pin               | 3. Reverse shift fork    |
| 4. Reverse fork rod    | 5. Return spring               | 6. Striking rod assembly |
| 7. Striking rod shim   | 8. Striking rod adjusting shim | 9. Shifter lever A       |
| 10. Shifter lever B    | 11. Guide bolt                 | 12. Selector lever       |
| 13. Transaxle case     | 14. 3rd-4th shift fork         | 15. 3rd-4th fork rod     |
| 16. 1st-2nd shift fork | 17. 1st-2nd fork rod           | 18. 5th-6th shift fork   |
| 19. 5th-6th fork rod   |                                |                          |

■ : Replace the parts as a set.

⊗ : Always replace after every disassembly.

FINAL DRIVE

# TRANSAXLE ASSEMBLY

< UNIT DISASSEMBLY AND ASSEMBLY >

[6MT: RS6F52H]

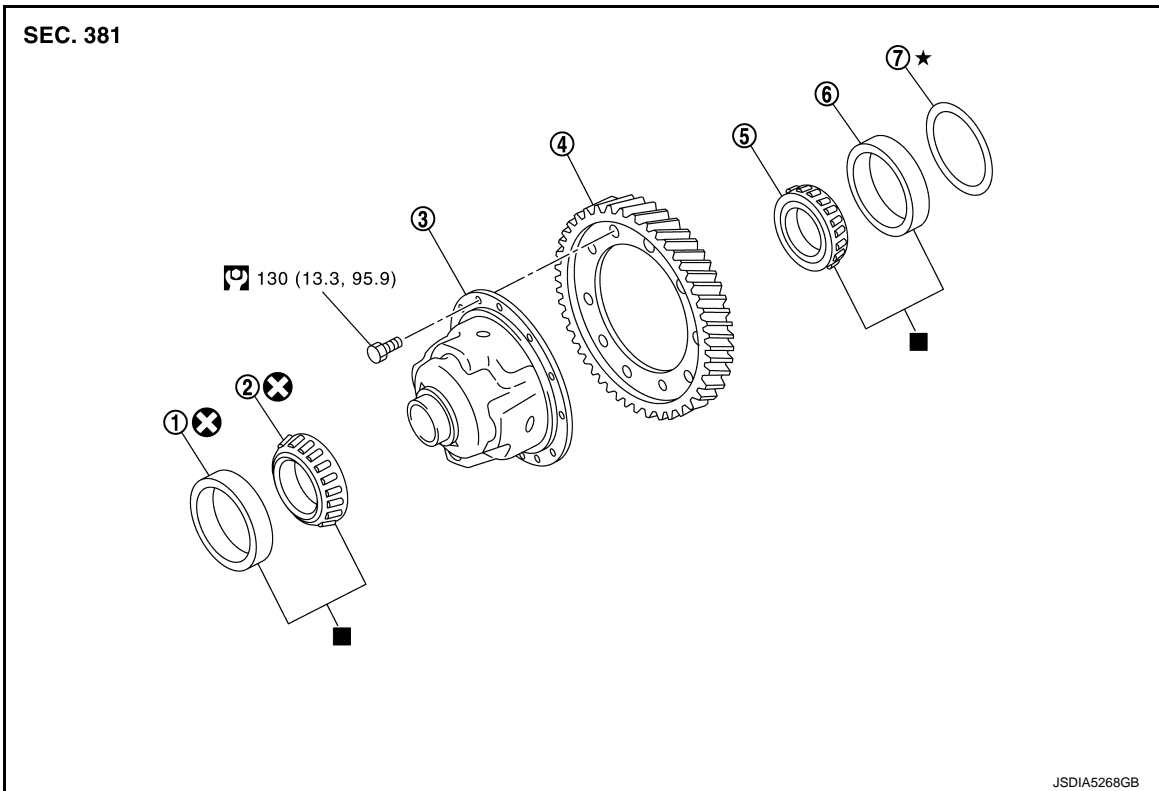

- |   |  |   |
|---|--|---|
| 1. Differential side bearing outer race (clutch housing side) | 2. Differential side bearing (clutch housing side) | 3. Differential case assembly                                 |
| 4. Final gear   | 5. Differential side bearing (transaxle case side) | 6. Differential side bearing outer race (transaxle case side) |
| 7. Differential side bearing adjusting shim                   |  |   |

■ : Replace the parts as a set.

🔧 : N·m (kg·m, ft·lb)

## Disassembly

INFOID:0000000010291438

### DISASSEMBLY

1. Remove drain plug and gasket from clutch housing.

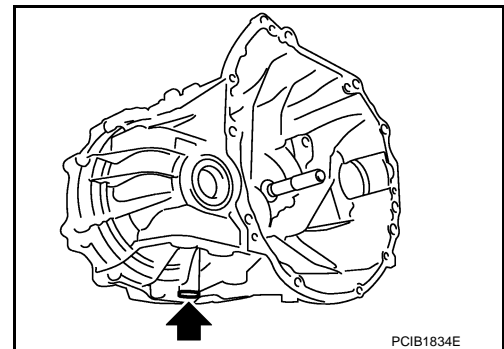

A  
B  
C  
TM  
E  
F  
G  
H  
I  
J  
K  
L  
M  
N  
O  
P

# TRANSAXLE ASSEMBLY

< UNIT DISASSEMBLY AND ASSEMBLY >

[6MT: RS6F52H]

2. Remove plug bolt and then plug and O-ring from clutch housing.

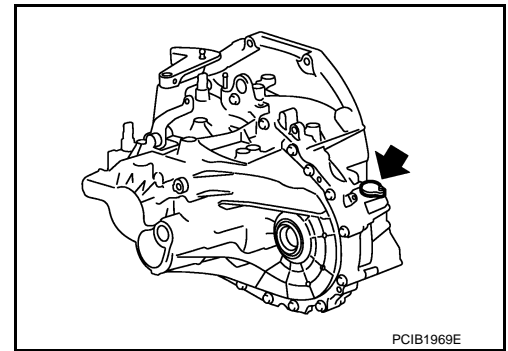

3. Remove plug and gasket from transaxle case.

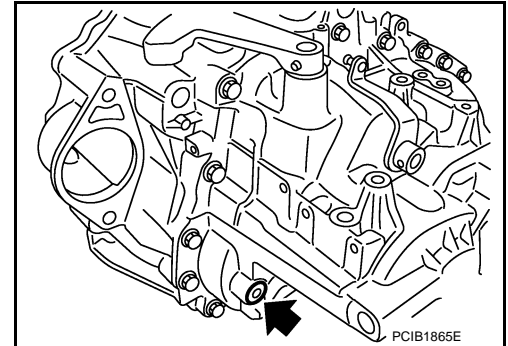

4. Remove park/neutral position (PNP) switch (1) from transaxle case.

5. Remove back-up lamp switch (2) and plunger from transaxle case.

**CAUTION:**

**Do not lose plunger.**

6. Remove air breather tube (3) from transaxle case.

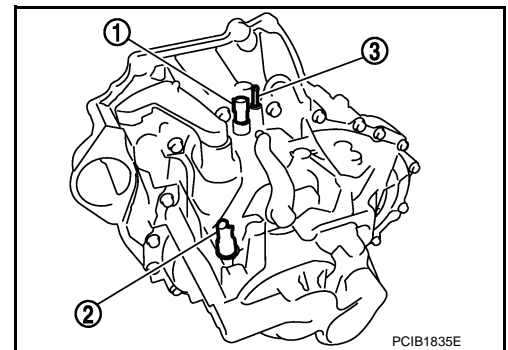

7. Remove guide bolt from transaxle case.

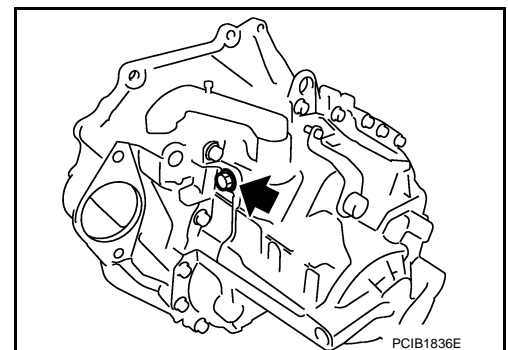

8. Remove retaining pin using suitable tool and then remove selector lever from transaxle case.

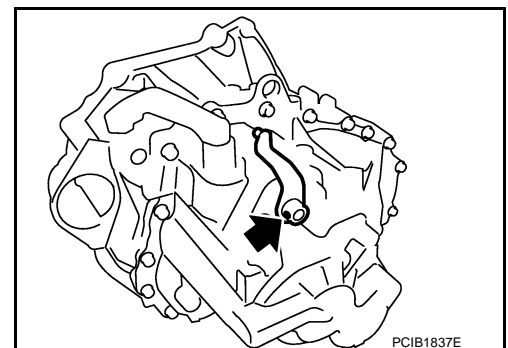



# TRANSAXLE ASSEMBLY

< UNIT DISASSEMBLY AND ASSEMBLY >

[6MT: RS6F52H]

9. Remove transaxle case bolts.

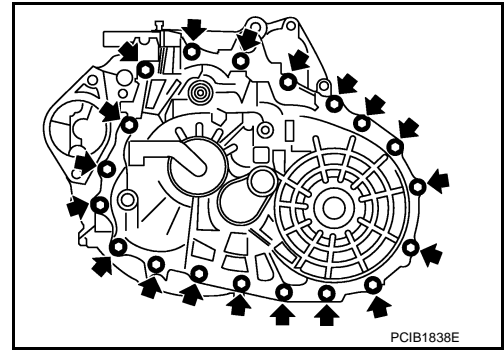

A  
B  
C

10. Remove bore plug from transaxle case using suitable tool.

**CAUTION:**

- Do not damage transaxle case.
- Access bore plug from cutout (A) of transaxle case when removing.

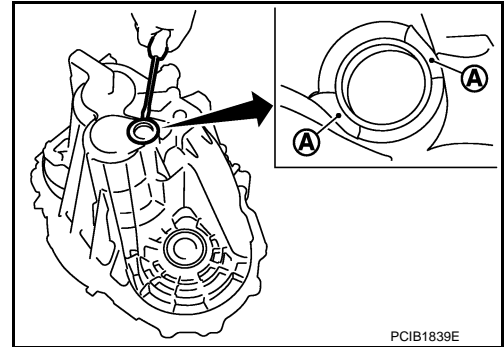

TM

E  
F  
G

11. Remove transaxle case following the procedures below.

a. Expand snap ring at mainshaft rear bearing accessing from the bore plug hole. Then pull up transaxle case from clutch housing until snap ring comes off.

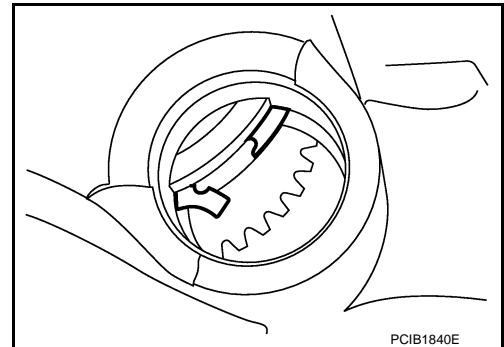

H  
I  
J

b. With shifter lever A (1) held in the position shown, remove transaxle case from clutch housing.

**CAUTION:**

**Do not drop adjusting shims.**

**NOTE:**

Make sure to hold shifter lever A in the position shown. Otherwise transaxle case cannot be removed from clutch housing.

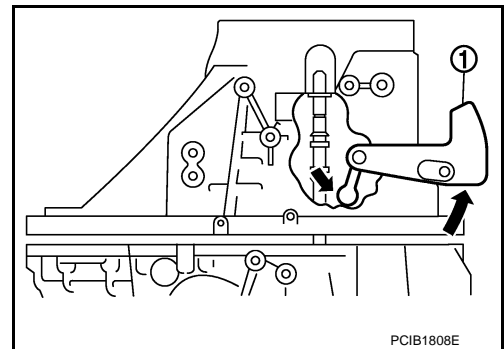

K  
L  
M

N  
O  
P

# TRANSAXLE ASSEMBLY

< UNIT DISASSEMBLY AND ASSEMBLY >

[6MT: RS6F52H]

12. Remove oil gutter A (1) and oil gutter B (2) from transaxle case.

A : Tab of oil gutter

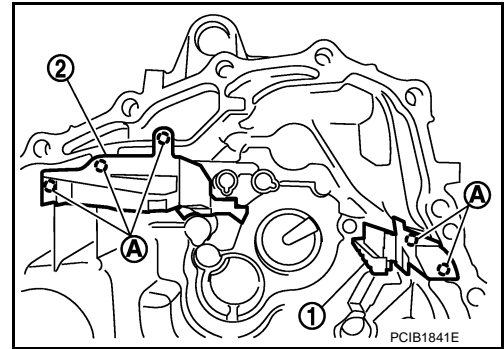

13. Remove snap ring from transaxle case.

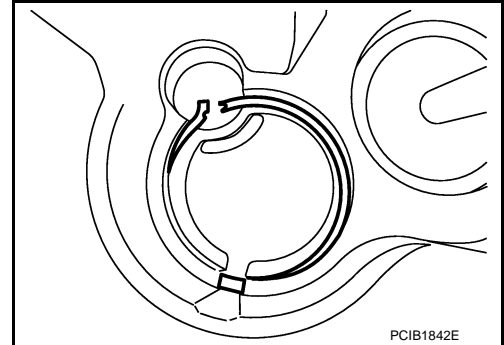

14. Remove retaining pin using suitable tool and then remove shifter lever A and shifter lever B from transaxle case.

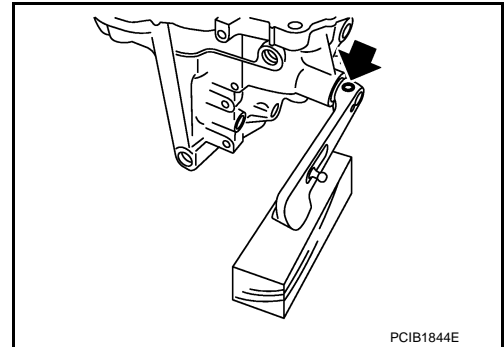

15. Remove differential side bearing outer race (transaxle case side) from transaxle case using Tool. Then remove differential side bearing adjusting shim from transaxle case.

**Tool number** : KV381054S0 (J-34286)

**CAUTION:**  
Do not damage transaxle case or differential side bearing outer race.

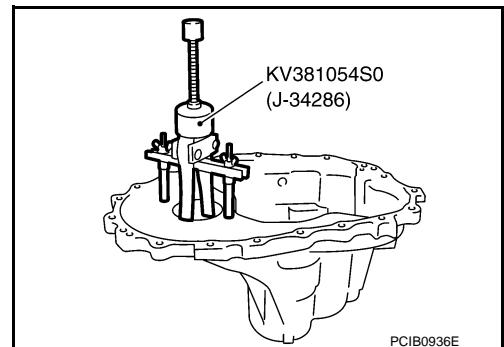

16. Remove differential side oil seal from transaxle case using suitable tool.

**CAUTION:**  
Do not damage transaxle case.

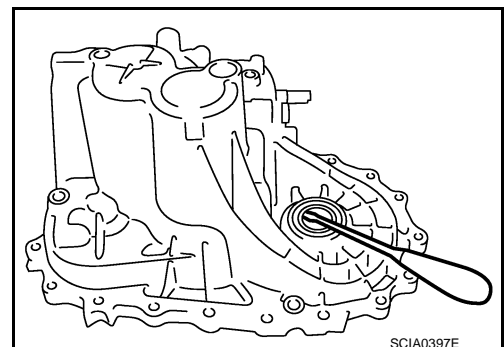

# TRANSAXLE ASSEMBLY

< UNIT DISASSEMBLY AND ASSEMBLY >

[6MT: RS6F52H]

17. Remove shifter lever oil seal (1) and striking rod oil seal (2) from transaxle case.

**CAUTION:**

**Do not damage transaxle case.**

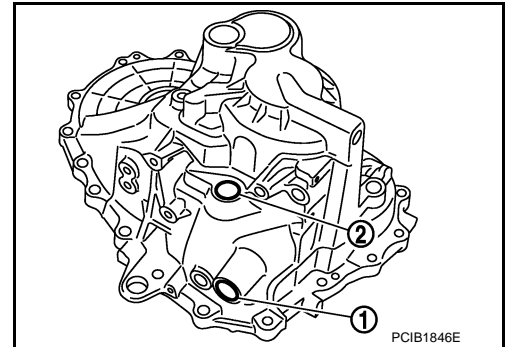

18. Remove striking rod shim (1), striking rod adjusting shim (2), mainshaft rear bearing adjusting shim (3), input shaft rear bearing adjusting shim (4), and reverse idler gear adjusting shim (5).

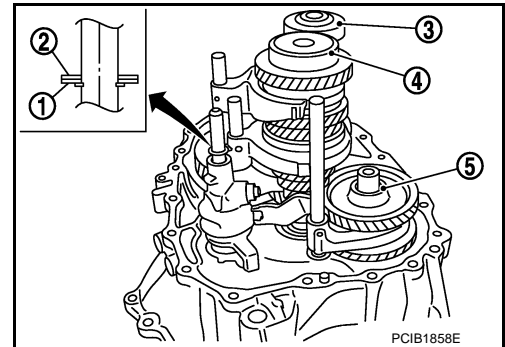

19. Remove retaining pin of reverse shift fork (1) using suitable tool.

2 : Reverse fork rod

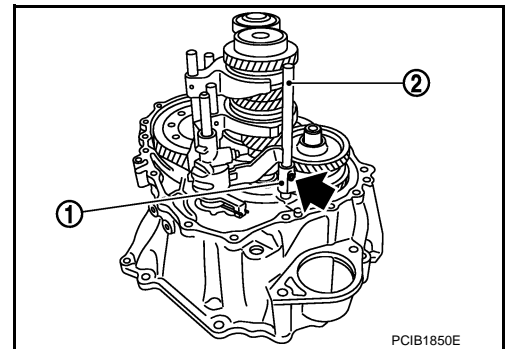

20. Rotate striking lever of striking rod assembly as shown. Then rotate reverse fork rod to a position where bracket of reverse fork rod does not interfere with striking lever of striking rod assembly.

21. Pull out reverse shift fork and reverse fork rod.

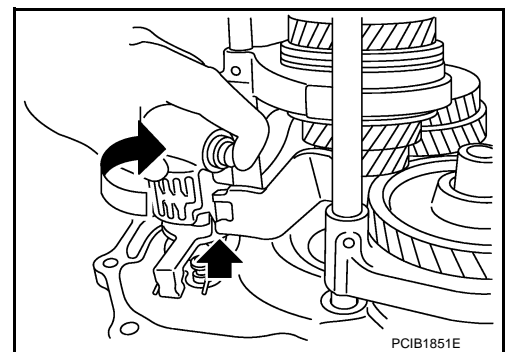

22. Remove retaining pin of 5th-6th shift fork (1) using suitable tool.

2 : 5th-6th fork rod

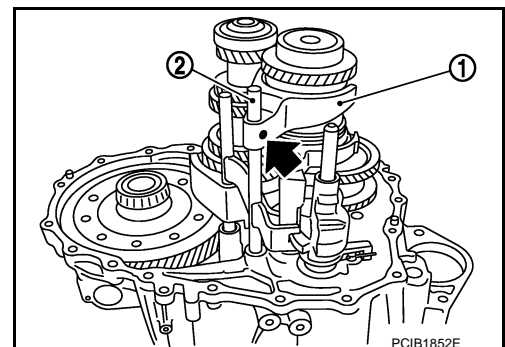

A  
B  
C  
TM  
E  
F  
G  
H  
I  
J  
K  
L  
M  
N  
O  
P

# TRANSAXLE ASSEMBLY

< UNIT DISASSEMBLY AND ASSEMBLY >

[6MT: RS6F52H]

- 23. Remove retaining pin of 3rd-4th shift fork (1) using suitable tool.
- 24. Pull out 3rd-4th fork rod (2).

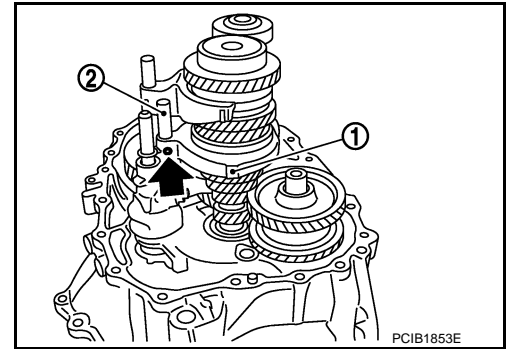

- 25. Pull out 5th-6th shift fork (1) and 5th-6th fork rod (2).

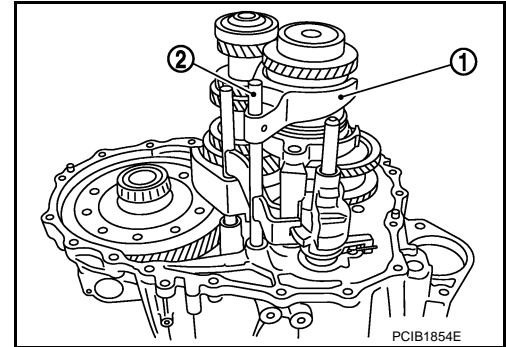

- 26. Pull out 3rd-4th shift fork (1).

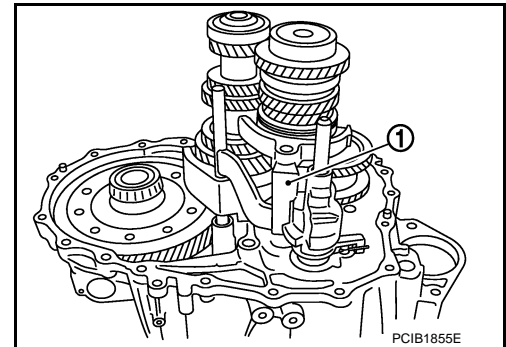

- 27. Remove retaining pin of 1st-2nd shift fork (1) using suitable tool.
- 28. Pull out 1st-2nd shift fork and 1st-2nd fork rod (2).

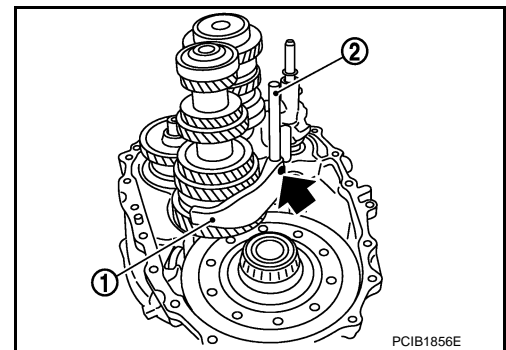

- 29. Remove striking rod assembly (1).

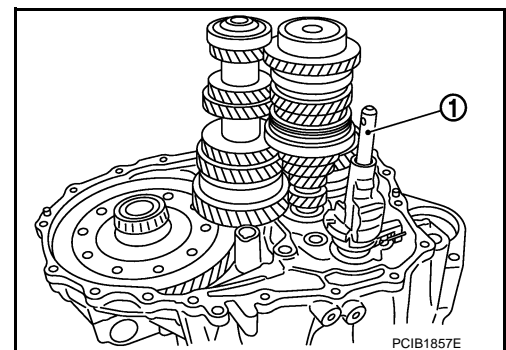

# TRANSAXLE ASSEMBLY

< UNIT DISASSEMBLY AND ASSEMBLY >

[6MT: RS6F52H]

30. Remove gear components from clutch housing in the following procedure.

- a. Remove a set of input shaft assembly, mainshaft assembly, and reverse idler gear assembly by tapping the tip of input shaft from the back of the clutch housing with a plastic hammer.

**CAUTION:**

**Always withdraw mainshaft straight out. Failure to do so can damage resin oil channel on clutch housing side.**

- b. Remove final drive assembly.

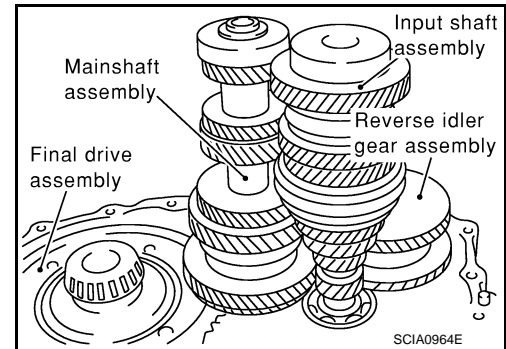

31. Remove magnet from clutch housing.

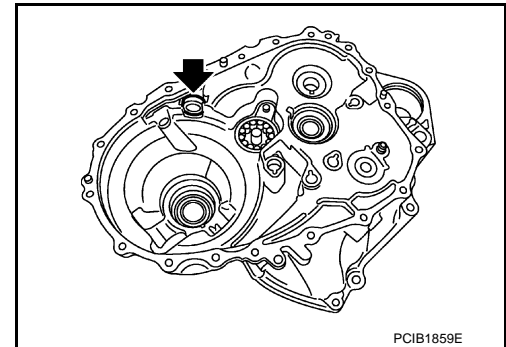

32. Remove mainshaft bearing retainer and then mainshaft front bearing from clutch housing using the Tool.

**Tool number : KV381054S0 (J-34286)**

**CAUTION:**

**Do not damage clutch housing, mainshaft front bearing, or oil channel.**

33. Remove oil channel from clutch housing.

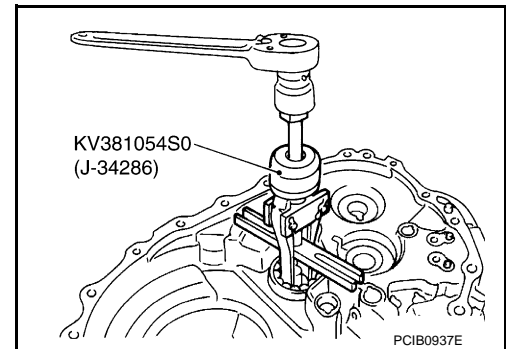

34. Remove differential side bearing outer race (clutch housing side) from clutch housing using the puller.

**Tool number : KV381054S0 (J-34286)**

**CAUTION:**

**Do not damage clutch housing or differential side bearing outer race.**

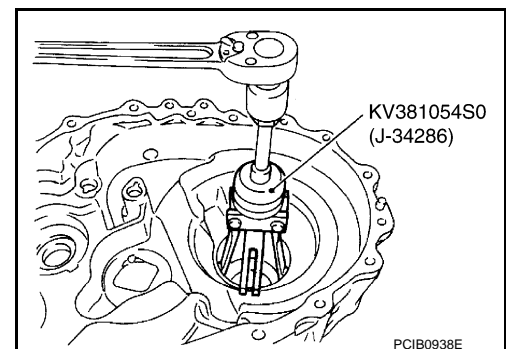

35. Remove input shaft oil seal from clutch housing, using a suitable tool.

**CAUTION:**

**Do not damage clutch housing.**

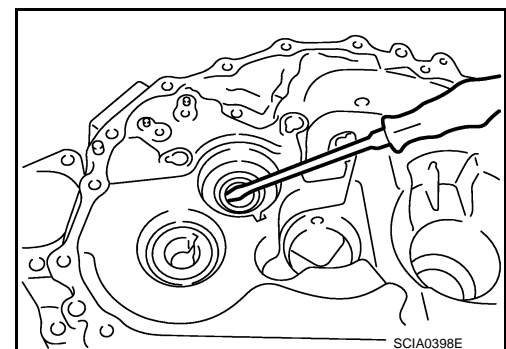

A  
B  
C  
TM  
E  
F  
G  
H  
I  
J  
K  
L  
M  
N  
O  
P

# TRANSAXLE ASSEMBLY

< UNIT DISASSEMBLY AND ASSEMBLY >

[6MT: RS6F52H]

36. Remove differential side oil seal from clutch housing, using a suitable tool.

**CAUTION:**

**Do not damage clutch housing.**

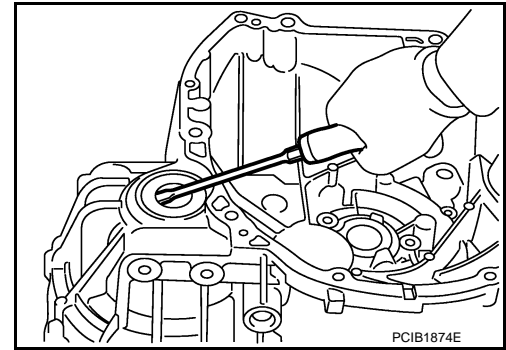

## Assembly

INFOID:000000010291439

### ASSEMBLY

1. Install differential side oil seal (1) to clutch housing using Tool (A).

**Dimension (H) : -0.5 - 0.5 mm (-0.020 - 0.020 in)**

**Tool number : ST33400001 (J-26082)**

**CAUTION:**

- Do not reuse differential side oil seal.
- When installing, do not incline differential side oil seal.
- Do not damage clutch housing.

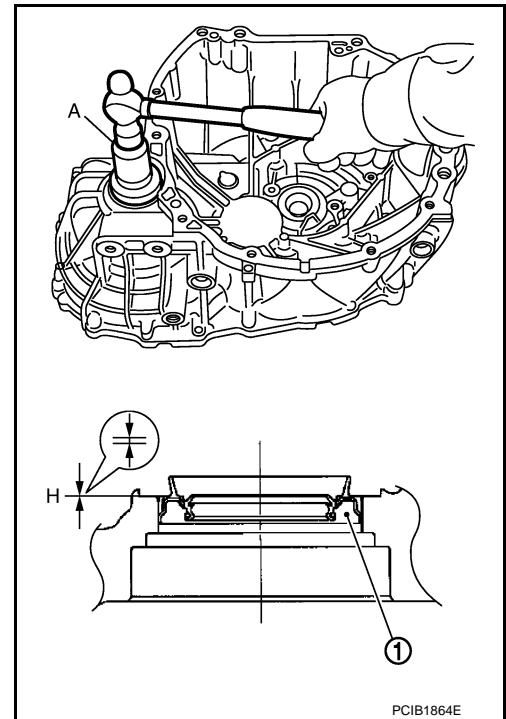

# TRANSAXLE ASSEMBLY

< UNIT DISASSEMBLY AND ASSEMBLY >

[6MT: RS6F52H]

2. Install input shaft oil seal (1) to clutch housing using Tool (A).

**Dimension (H) : 1.1 - 2.0 mm (0.043 - 0.078 in)**

**Tool number : ST35321000 ( — )**

**CAUTION:**

- Do not reuse input shaft oil seal.
- When installing, do not incline input shaft oil seal.
- Do not damage clutch housing.

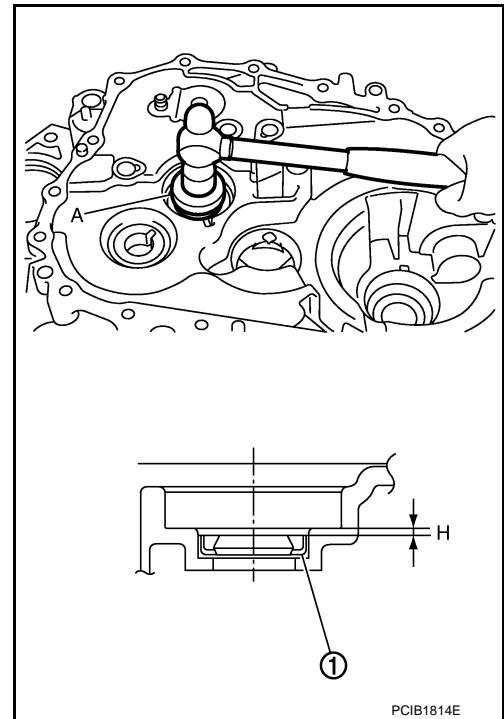

3. Install differential side bearing outer race (clutch housing side) to clutch housing using Tools.

**Tool number : KV40105320 ( — )**  
**: ST30720000 (J-25405)**

**CAUTION:**

**Replace differential side bearing and differential side bearing outer race as a set.**

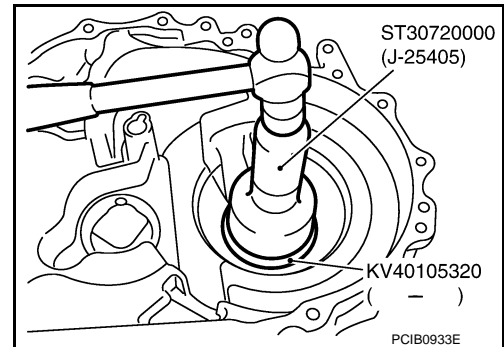

4. Install oil channel (1) on mainshaft side.

**CAUTION:**

**When installing oil channel, fit the rib (A) of oil channel into the processed area of the spot facing (B).**

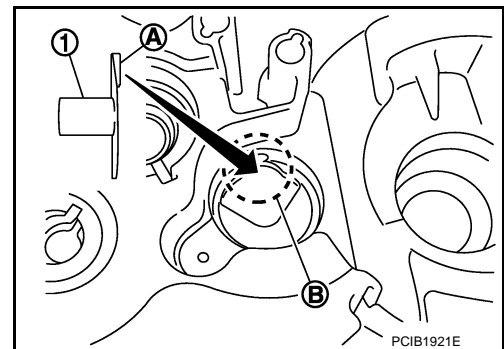

5. Install mainshaft front bearing to clutch housing using Tool.

**Tool number : ST33200000 (J-26082)**

**CAUTION:**

**Be careful with the orientation of mainshaft front bearing.**

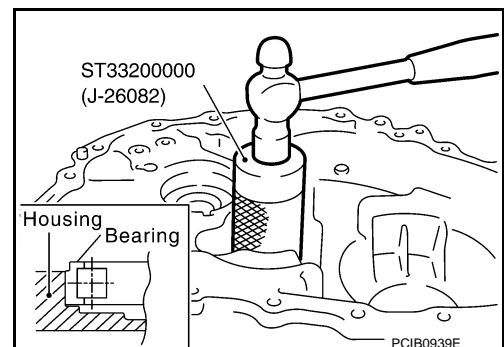

A  
B  
C  
TM  
E  
F  
G  
H  
I  
J  
K  
L  
M  
N  
O  
P

# TRANSAXLE ASSEMBLY

## < UNIT DISASSEMBLY AND ASSEMBLY >

[6MT: RS6F52H]

6. Install mainshaft bearing retainer (1) to clutch housing and tighten bolt to the specified torque.

- 2 : Mainshaft front bearing  
3 : Oil channel

**CAUTION:**  
Install with punched surface facing up.

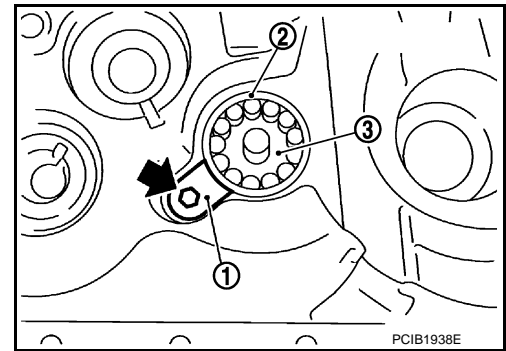

7. Install magnet to clutch housing.

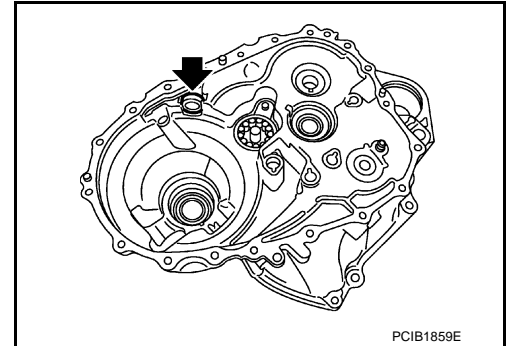

8. Install final drive assembly into clutch housing.

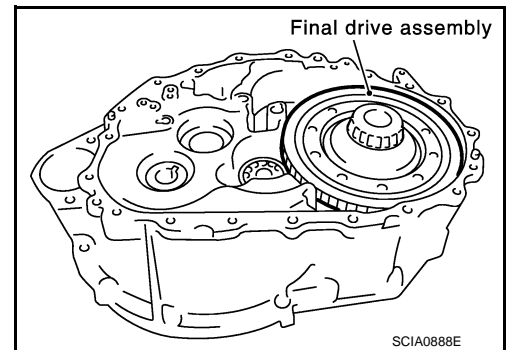

9. Install input shaft assembly, mainshaft assembly, and reverse idler gear assembly into clutch housing.

**CAUTION:**

- Wrap a tape, etc. to the spline of input shaft so as not to damage the input shaft oil seal.
- Be careful with the orientation of reverse idler shaft.

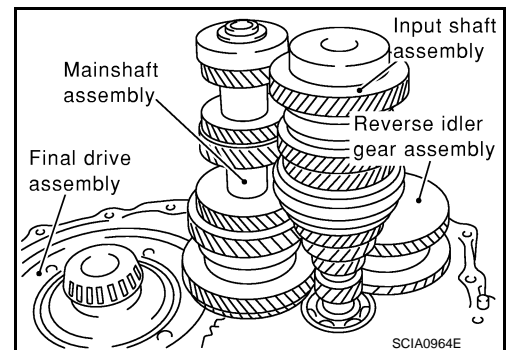

10. Install striking rod assembly (1) into clutch housing.

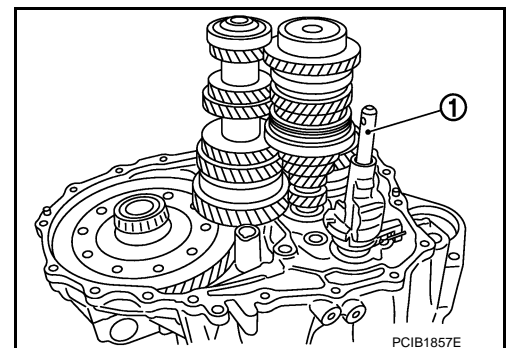



# TRANSAXLE ASSEMBLY

< UNIT DISASSEMBLY AND ASSEMBLY >

[6MT: RS6F52H]

**CAUTION:**

- Check that return spring is securely seated in the groove on return pin.

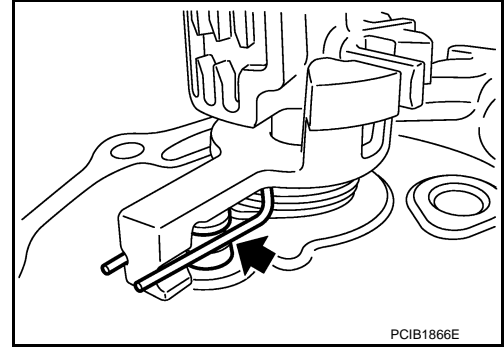

11. Install 1st-2nd shift fork (1) and 1st-2nd fork rod (2) and then install retaining pin to 1st-2nd shift fork.

**CAUTION:**

- Do not reuse retaining pin.
- Be careful with the orientation of 1st-2nd shift fork and 1st-2nd fork rod.
- Assemble retaining pin from the direction shown by the arrow until it becomes flush with the end surface of 1st-2nd shift fork.

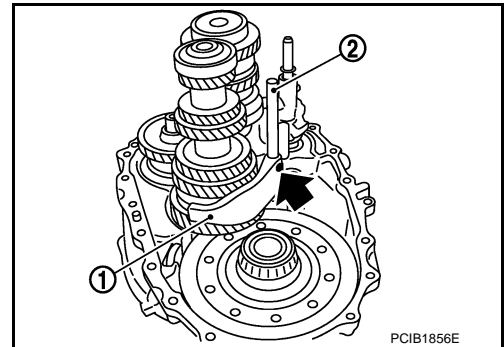

12. Install 3rd-4th shift fork (1) to 3rd-4th coupling sleeve.

**CAUTION:**

- Be careful with the orientation of 3rd-4th shift fork.

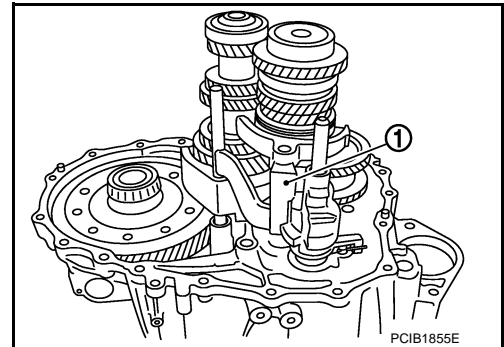

13. Install 5th-6th shift fork (1) and 5th-6th fork rod (2) and then install retaining pin to 5th-6th shift fork.

**CAUTION:**

- Do not reuse retaining pin.
- Be careful with the orientation of 5th-6th shift fork and 5th-6th fork rod.
- Assemble retaining pin from the direction shown by the arrow until it becomes flush with the end surface of 5th-6th shift fork.

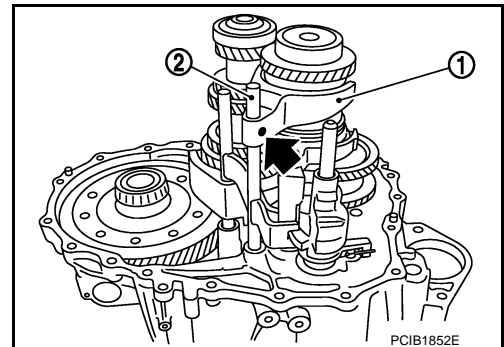

A  
B  
C  
TM  
E  
F  
G  
H  
I  
J  
K  
L  
M  
N  
O  
P

# TRANSAXLE ASSEMBLY

< UNIT DISASSEMBLY AND ASSEMBLY >

[6MT: RS6F52H]

14. Install 3rd-4th fork rod (2) and then install retaining pin to 3rd-4th shift fork (1).

**CAUTION:**

- Do not reuse retaining pin.
- Be careful with the orientation of 3rd-4th fork rod.
- Assemble retaining pin from the direction shown by the arrow until it becomes flush with the end surface of 3rd-4th shift fork.

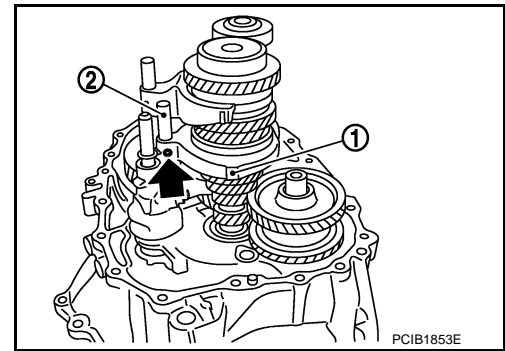

15. Install reverse shift fork (1) and reverse fork rod (2).

**CAUTION:**

- Be careful with the orientation of reverse shift fork and reverse fork rod.

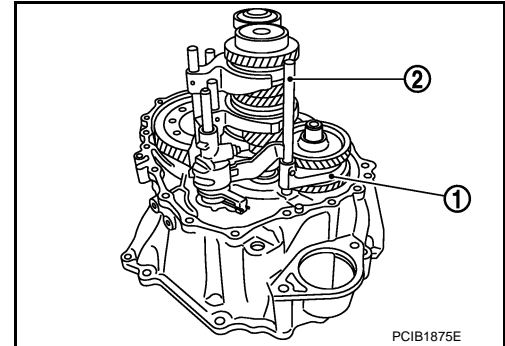

16. Rotate striking lever of striking rod assembly as shown. Then rotate reverse fork rod to a position where bracket of reverse fork rod does not interfere with striking lever of striking rod assembly.

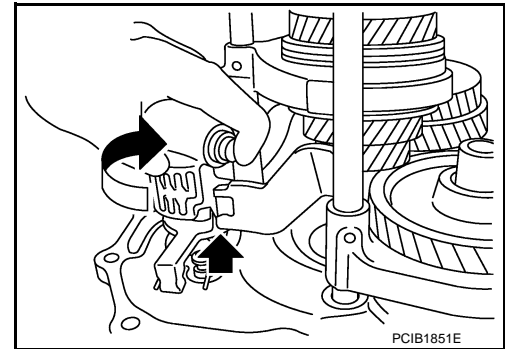

17. Install retaining pin to reverse shift fork (1).

2 : Reverse fork rod

**CAUTION:**

- Do not reuse retaining pin.
- Assemble retaining pin from the direction shown by the arrow until it becomes flush with the end surface of reverse shift fork.

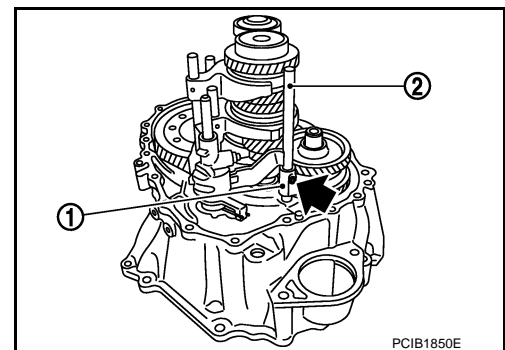

18. Install selected differential side bearing adjusting shim(s) and differential side bearing outer race (transaxle case side).
19. Install selected reverse idler gear adjusting shim onto reverse idler gear assembly.
20. Install selected input shaft rear bearing adjusting shim onto input shaft.
21. Install selected striking rod adjusting shim and striking rod shim onto striking rod assembly.

# TRANSAXLE ASSEMBLY

< UNIT DISASSEMBLY AND ASSEMBLY >

[6MT: RS6F52H]

22. Install shifter lever oil seal (1) and striking rod oil seal (2) to transaxle case using suitable tool.

**Dimension (H) : 0 - 1.0 mm (0 - 0.039 in)**

**CAUTION:**

- Do not reuse shifter lever oil seal or striking rod oil seal.
- When installing, do not incline shifter lever oil seal and striking rod oil seal.
- Do not damage transaxle case.

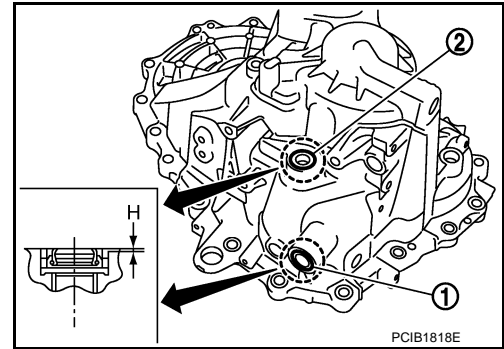

23. Install differential side oil seal (1) to transaxle case using Tool (A).

**Dimension (H) : -0.5 - 0.5 mm (-0.020 - 0.020 in)**

**Tool number : ST30720000 (J-25405)**

**CAUTION:**

- Do not reuse differential side oil seal.
- When installing, do not incline differential side oil seal.
- Do not damage transaxle case.

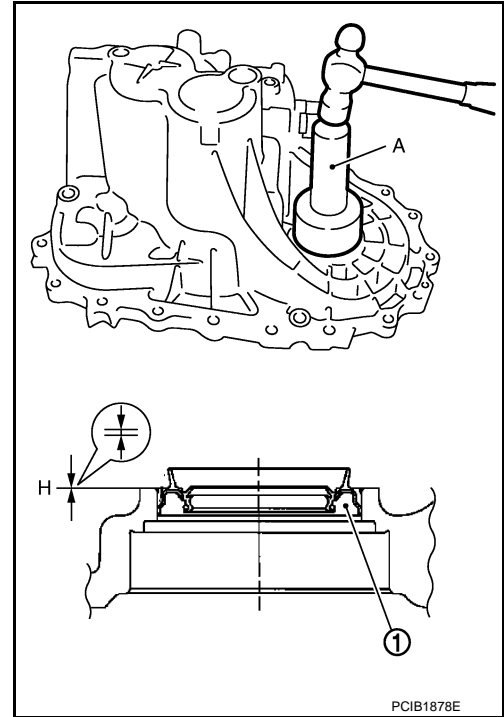

24. Install shifter lever B (1) and shifter lever A (2) to transaxle case.

**CAUTION:**

**Be careful with the orientation of shifter lever B and shifter lever A.**

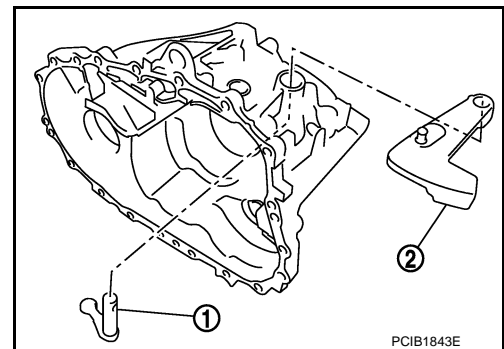

25. Install retaining pin to shifter lever A.

**CAUTION:**

- Do not reuse retaining pin.
- Assemble retaining pin from the direction shown by the arrow until it becomes flush with the end surface of shifter lever A.

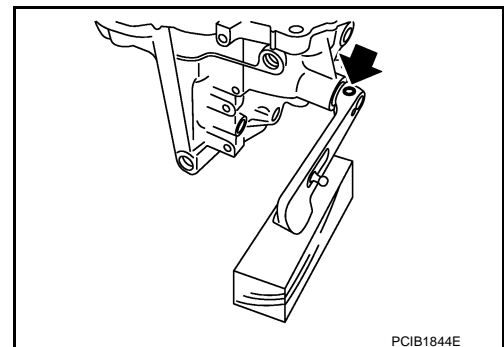

A  
B  
C  
TM  
E  
F  
G  
H  
I  
J  
K  
L  
M  
N  
O  
P

# TRANSAXLE ASSEMBLY

< UNIT DISASSEMBLY AND ASSEMBLY >

[6MT: RS6F52H]

26. Install transaxle case following the procedures below.
- Install selected mainshaft rear bearing adjusting shim into transaxle case.
  - Install oil gutter A (1) and oil gutter B (2) to transaxle case.

**CAUTION:**

Insert the tab (A) of oil gutter A and oil gutter B into transaxle case.

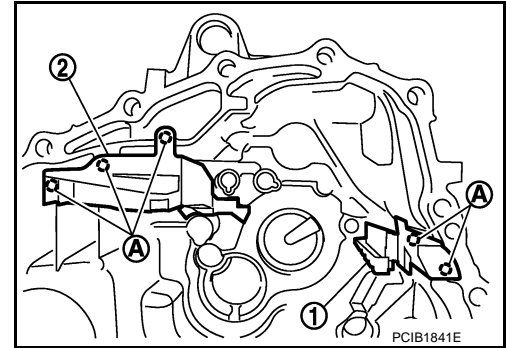

- Temporarily install snap ring of mainshaft rear bearing into transaxle case.

**CAUTION:**

Do not reuse snap ring.

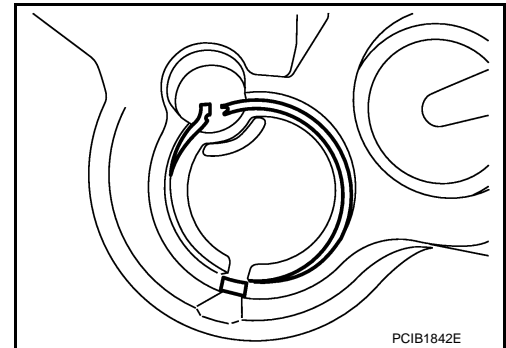

- Apply recommended sealant to mating surface of clutch housing as shown.

• Use Genuine Silicone RTV or an equivalent. Refer to [MA-10, "Fluids and Lubricants"](#).

**CAUTION:**

- Remove old sealant adhering to the mounting surfaces. Also remove any moisture, oil, or foreign material adhering to both mounting surfaces.
- Apply sealant so as not to break the bead.
- The width of sealant bead is 1 - 2 mm (0.04 - 0.08 in).
- The height of sealant bead is 0.4 - 1 mm (0.016 - 0.04 in).
- The overlap length of both ends of sealant bead is 3 - 5 mm (0.12 - 0.20 in).

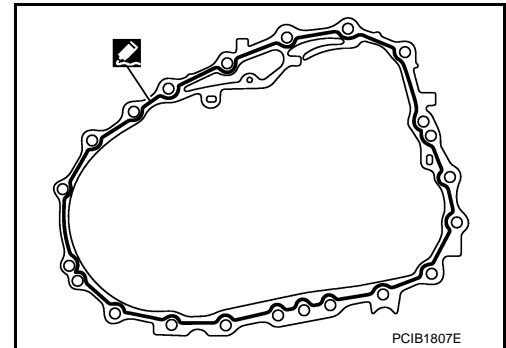

- With shifter lever A (1) held in the position shown, temporarily assemble transaxle case to clutch housing.

**CAUTION:**

Do not damage striking rod oil seal.

**NOTE:**

Make sure to hold shifter lever A in the position shown. Otherwise transaxle case cannot be installed to clutch housing.

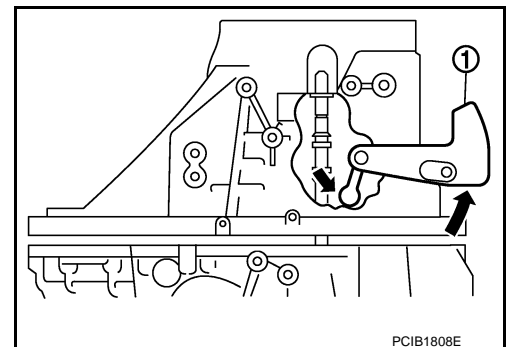

# TRANSAXLE ASSEMBLY

< UNIT DISASSEMBLY AND ASSEMBLY >

[6MT: RS6F52H]

- f. While rotating shifter lever A (1) in the direction of the arrow shown, assemble transaxle case to clutch housing.

2 : shifter lever B

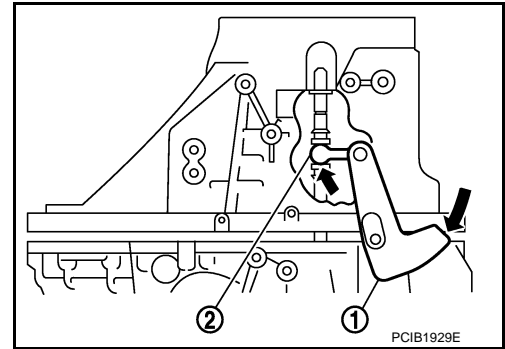

- g. Accessing from the bore plug hole, expand snap ring at mainshaft rear bearing so that the ring catches the periphery of mainshaft rear bearing.  
h. Temporarily tighten transaxle case bolts.

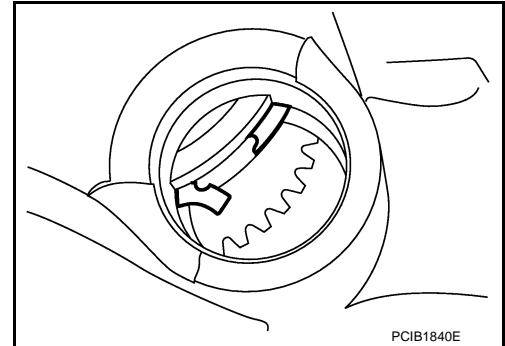

- i. Shift the shifter lever A (1) to 2nd gear position.

**NOTE:**

- The 2nd gear position is attained when shifter lever A is in the position shown.

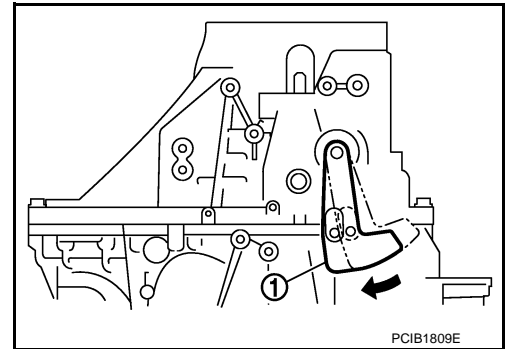

- When transaxle is shifted to the 2nd gear position, mainshaft assembly is lifted.

- j. Seat snap ring in the groove on mainshaft rear bearing. If snap ring is not seated in the groove on mainshaft rear bearing, remove transaxle case and repeat the procedure from step d.

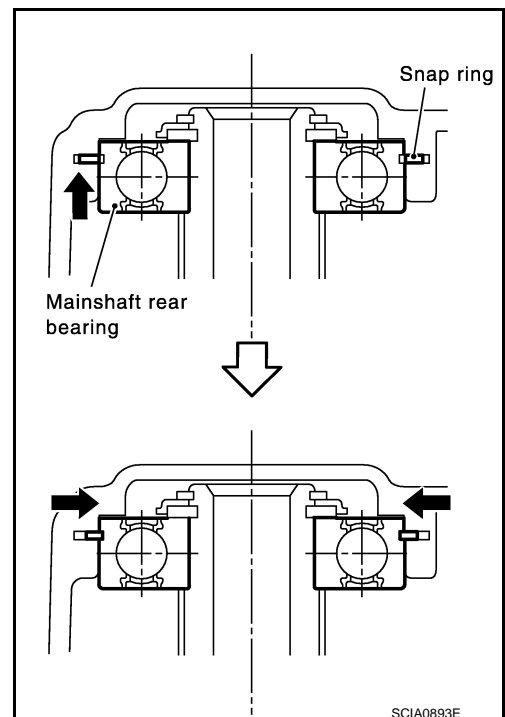

A  
B  
C  
TM  
E  
F  
G  
H  
I  
J  
K  
L  
M  
N  
O  
P

# TRANSAXLE ASSEMBLY

< UNIT DISASSEMBLY AND ASSEMBLY >

[6MT: RS6F52H]

k. Tighten transaxle case bolts to the specified torque.

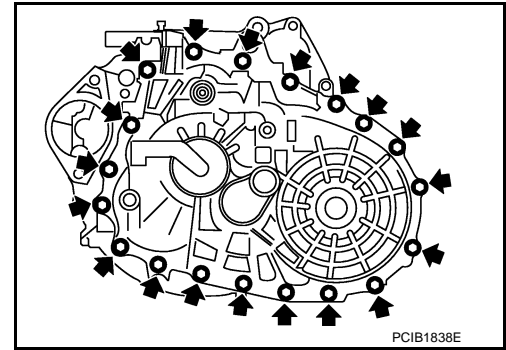

l. Shift the shifter lever A (1) to neutral position.

**NOTE:**

The neutral position is attained when shifter lever A is in the position shown.

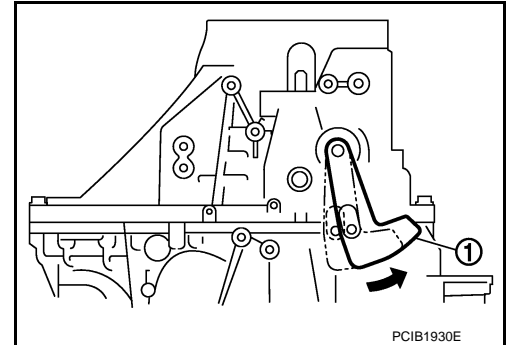

27. Install bore plug to transaxle case using Tool.

**Tool number : ST33061000 (J-8107-2)**

**CAUTION:**

**Do not reuse bore plug.**

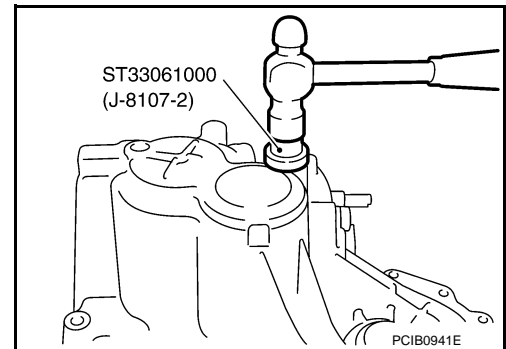

28. Install selector lever to transaxle case and then install retaining pin to selector lever.

**CAUTION:**

- Do not reuse retaining pin.
- Assemble retaining pin from the direction shown by the arrow until it becomes flush with the end surface of selector lever.

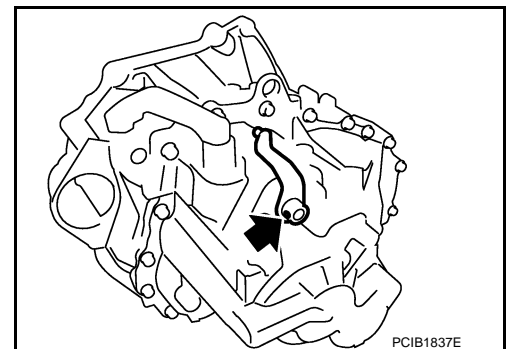

29. Install guide bolt following the procedures below.

a. Shift the shifter lever A and selector lever to neutral position.

# TRANSAXLE ASSEMBLY

< UNIT DISASSEMBLY AND ASSEMBLY >

[6MT: RS6F52H]

- b. Visually confirm from the guide bolt hole (C) that the lever is securely set to neutral position (A). If it is not in the neutral position, repeat the procedure from step a.

1 : Guide bolt

**CAUTION:**

The guide groove (D) of striking rod assembly will be damaged when assembling guide bolt with the lever is in except neutral position (B).

- c. Check continuity between terminals of park/neutral position (PNP) switch to confirm it in the neutral position. If it is not in the neutral position, remove park/neutral position (PNP) switch and repeat the procedure from step a. Refer to [TM-73, "PARK/NEUTRAL POSITION \(PNP\) SWITCH : Component Inspection"](#).

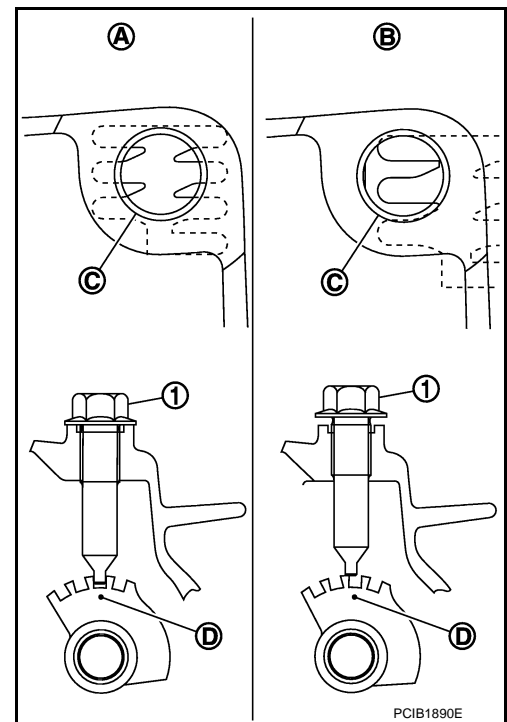

- d. Install guide bolt to transaxle case and then tighten guide bolt to the specified torque.

**CAUTION:**

Do not reuse guide bolt.

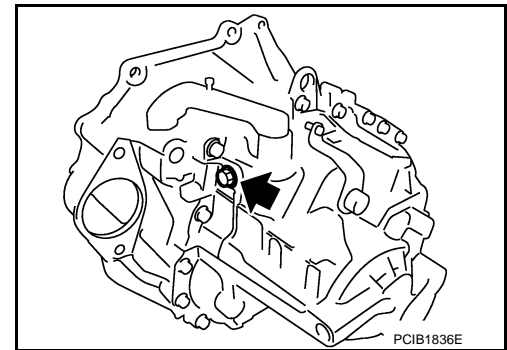

30. Apply recommended sealant to threads of park/neutral position (PNP) switch (1). Then install it to transaxle case and tighten to the specified torque.

• Use Genuine Silicone RTV or an equivalent. Refer to [MA-10, "Fluids and Lubricants"](#).

**CAUTION:**

Remove old sealant and oil adhering to threads.

31. Install plunger to transaxle case.

32. Apply recommended sealant to threads of back-up lamp switch (2). Then install it to transaxle case and tighten to the specified torque.

• Use Genuine Silicone RTV or an equivalent. Refer to [MA-10, "Fluids and Lubricants"](#).

**CAUTION:**

Remove old sealant and oil adhering to threads.

33. Install air breather tube (3) to transaxle case.

**CAUTION:**

• Do not reuse air breather tube.

• Assemble air breather tube until its collar element contacts with transaxle case.

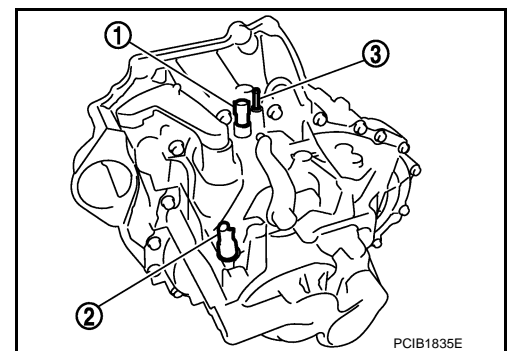

A  
B  
C  
TM  
E  
F  
G  
H  
I  
J  
K  
L  
M  
N  
O  
P

# TRANSAXLE ASSEMBLY

< UNIT DISASSEMBLY AND ASSEMBLY >

[6MT: RS6F52H]

34. Install gasket onto plug and then install them into transaxle case. Tighten plug to the specified torque.

**CAUTION:**  
Do not reuse gasket.

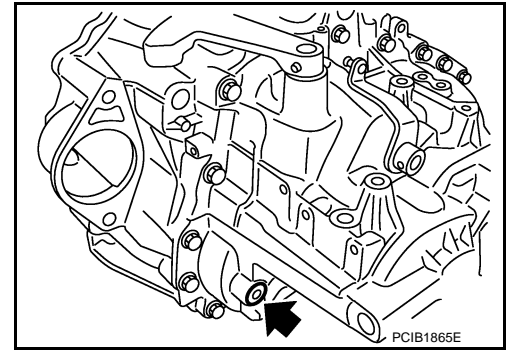

35. Install gasket onto drain plug and then install them into clutch housing. Tighten drain plug to the specified torque.

**CAUTION:**  
Do not reuse gasket.

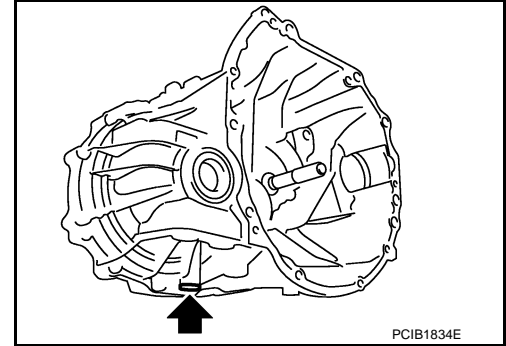

36. Install O-ring onto plug and then install it into clutch housing. Tighten bolt to the specified torque.

**CAUTION:**

- Do not reuse O-ring.
- After oil is filled, tighten bolt to specified torque.

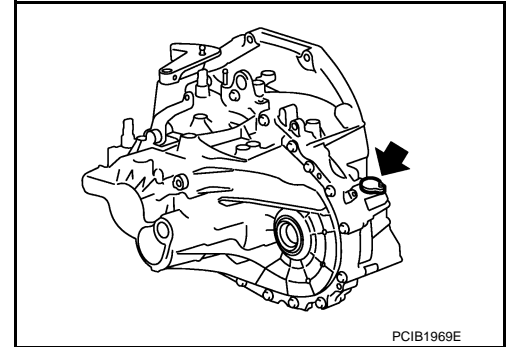

## Adjustment

INFOID:000000010291440

### ADJUSTMENT

#### Differential Side Bearing Preload

• When adjusting differential side bearing preload, select adjusting shim for differential side bearing. To select adjusting shim, measure clearance (L) between transaxle case and differential side bearing outer race. Refer to [TM-142, "Available Shims"](#).

**CAUTION:**

**Up to 2 adjusting shims can be selected.**

• Calculate dimension (L) (thickness of adjusting shim) using the following procedure to satisfy specification of preload for differential side bearing.

**Preload** : Refer to [TM-142, "Available Shims"](#).

**Dimension L = (L1 - L2) + Preload**

**L** : Thickness of adjusting shim

**L1** : Distance between transaxle case end face and mounting face of adjusting shim

**L2** : Distance between differential side bearing outer race and clutch housing end face

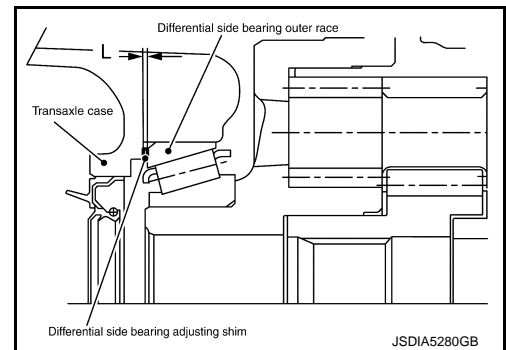



# TRANSAXLE ASSEMBLY

< UNIT DISASSEMBLY AND ASSEMBLY >

[6MT: RS6F52H]

- Using a depth micrometer and straightedge, measure dimension (L1) between transaxle case end face and mounting face of adjusting shim.
- Install differential side bearing outer race onto differential side bearing on final gear side. Holding lightly differential side bearing outer race horizontally by hand, rotate final gear five times or more (for smooth movement of bearing roller).

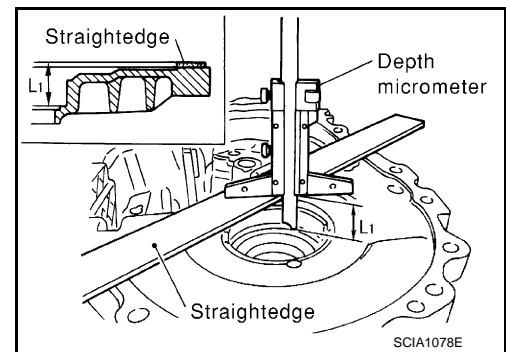

- Using a depth micrometer and straightedge as shown, measure dimension (L2) between differential side bearing outer race and clutch housing end face.

**CAUTION:**

**L2: Measure at 4 point by approximately 90 degrees and use the average value.**

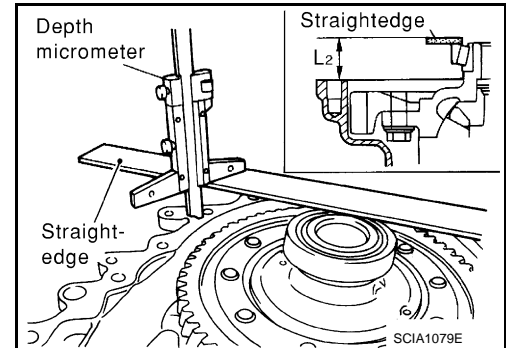

- Install selected differential side bearing adjusting shim and then install differential side bearing outer race (transaxle case side) using Tool.

**Tool number : ST30720000 (J25405)**

**CAUTION:**

**Replace differential side bearing and differential side bearing outer race as a set.**

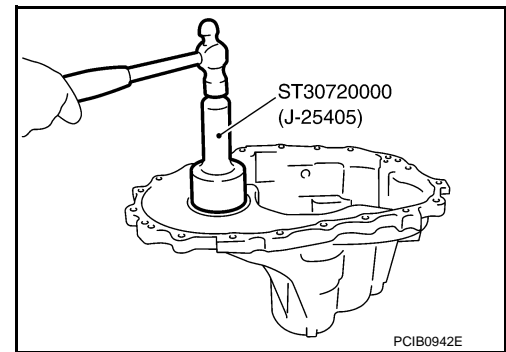

**Reverse Idler Gear End Play**

- When adjusting reverse idler gear end play, select adjusting shim for reverse idler gear. To select adjusting shim (1), measure clearance between transaxle case (2) and reverse idler gear (rear) (3). Refer to [TM-141](#). "Available Adjusting Shims".

**CAUTION:**

**Only 1 adjusting shim can be selected.**

- Calculate dimension (Q) (thickness of adjusting shim) using the following procedure to satisfy specification of end play for reverse idler gear.

**End play : Refer to [TM-141](#), "Available Adjusting Shims".**

**Dimension Q = (Q1 - Q2) - End play**

**Q : Thickness of adjusting shim**

**Q1 : Distance between transaxle case end face and mounting face of adjusting shim**

**Q2 : Distance between clutch housing end face and end face of reverse idler gear (rear)**

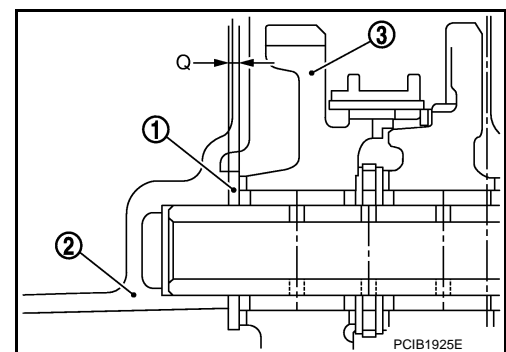

# TRANSAXLE ASSEMBLY

< UNIT DISASSEMBLY AND ASSEMBLY >

[6MT: RS6F52H]

- Using a depth micrometer and straightedge, measure dimension (Q1) between transaxle case end face and mounting face of adjusting shim.

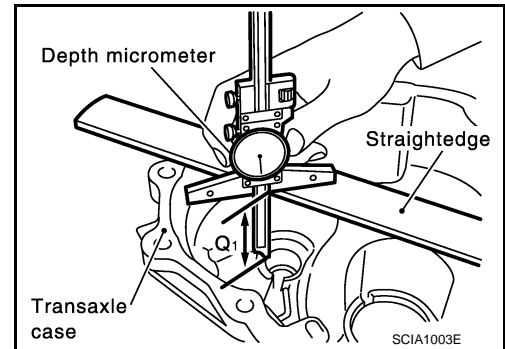

- Using a depth micrometer and straightedge as shown, measure dimension (Q2) between clutch housing (1) end face and end face of reverse idler gear (rear) (2).

**CAUTION:**

**Q2: Measure at 4 point by approximately 90 degrees and use the average value.**

- Install selected reverse idler gear adjusting shim onto reverse idler gear (rear).

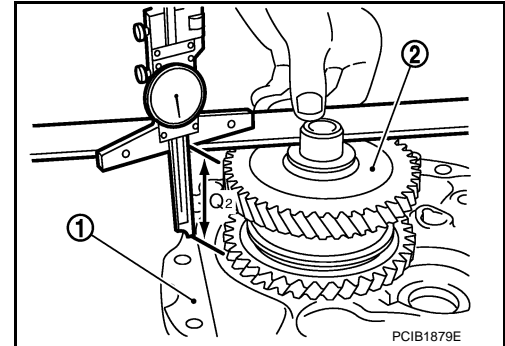

**Input Shaft End Play**

- When adjusting input shaft end play, select adjusting shim for input shaft rear bearing. To select adjusting shim, measure clearance between transaxle case and input shaft rear bearing. Refer to [TM-141, "Available Adjusting Shims"](#).

**CAUTION:**

**Only 1 adjusting shim can be selected.**

- Calculate dimension (O) (thickness of adjusting shim) using the following procedure to satisfy specification of end play for input shaft rear bearing.

**End play** : Refer to [TM-141, "Available Adjusting Shims"](#).

**Dimension O = (O1 - O2) - End play**

**O** : Thickness of adjusting shim

**O1** : Distance between transaxle case end face and mounting face of adjusting shim

**O2** : Distance between clutch housing end face and end face of input shaft rear bearing

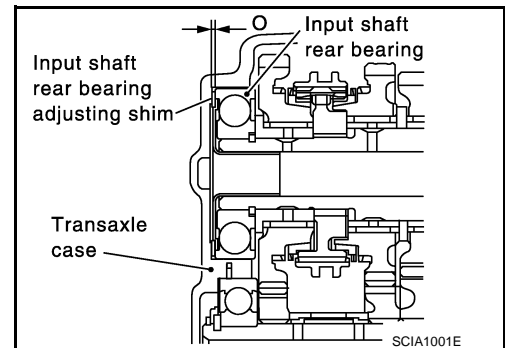

- Using a depth micrometer and straightedge, measure dimension (O1) between transaxle case end face and mounting face of adjusting shim.

**CAUTION:**

**O1: Measure at 4 point by approximately 90 degrees and use the average value.**

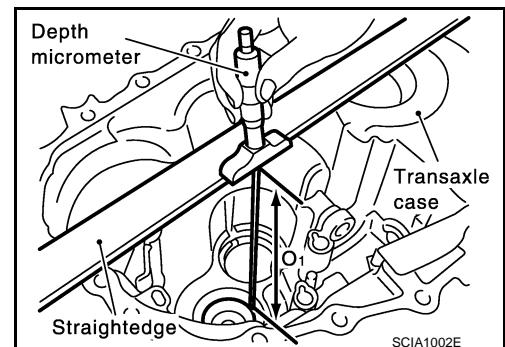

# TRANSAXLE ASSEMBLY

## < UNIT DISASSEMBLY AND ASSEMBLY >

[6MT: RS6F52H]

- Using a depth micrometer and straightedge as shown, measure dimension (O<sub>2</sub>) between clutch housing end face and end face of input shaft rear bearing.

**CAUTION:**

(O<sub>2</sub>): Measure at 4 point by approximately 90 degrees and use the average value.

- Install selected input shaft rear bearing adjusting shim onto input shaft.

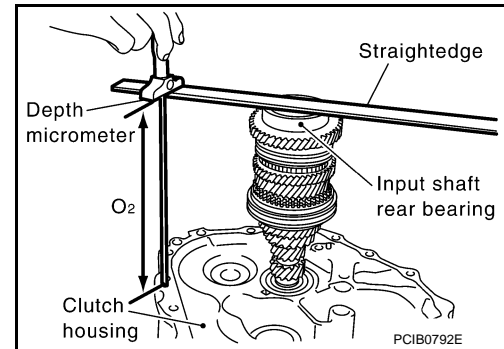

### Striking rod End Play

- When adjusting striking rod end play, select adjusting shim (1) for striking rod (2). To select adjusting shim, measure clearance between transaxle case (3) and striking rod shim (4). Refer to [TM-141, "Available Adjusting Shims"](#).

**CAUTION:**

**Only 1 adjusting shim can be selected.**

- Calculate dimension (R) (thickness of adjusting shim) using the following procedure to satisfy specification of end play for striking rod.

**End play** : Refer to [TM-141, "Available Adjusting Shims"](#).

**Dimension R = (R<sub>1</sub> - R<sub>2</sub>) - End play**

**R** : Thickness of adjusting shim

**R<sub>1</sub>** : Distance between transaxle case end face and mounting face of adjusting shim

**R<sub>2</sub>** : Distance between clutch housing end face and end face of striking rod shim

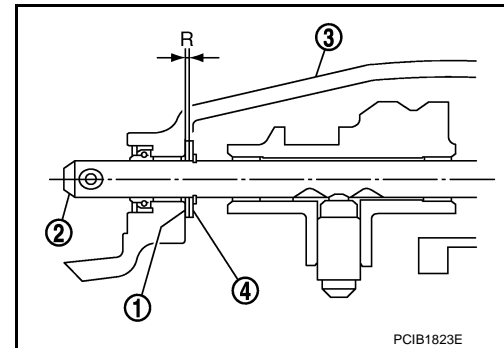

- Using a depth micrometer (A) and straightedge (B), measure dimension (R<sub>1</sub>) between transaxle case (1) end face and mounting face of adjusting shim.

**CAUTION:**

**R<sub>1</sub>: Measure at 4 point by approximately 90 degrees and use the average value.**

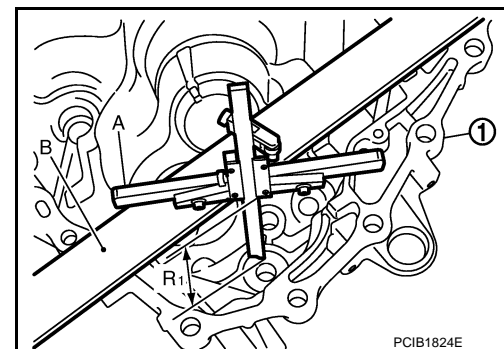

- Using a depth micrometer (A) and straightedge (B) as shown, measure dimension (R<sub>2</sub>) between clutch housing (1) end face and end face of striking rod shim (2).

**CAUTION:**

**R<sub>2</sub>: Measure at 4 point by approximately 90 degrees and use the average value.**

**When measuring, be careful for the inclination of striking rod assembly and striking rod shim.**

- Install selected striking rod adjusting shim onto striking rod assembly.

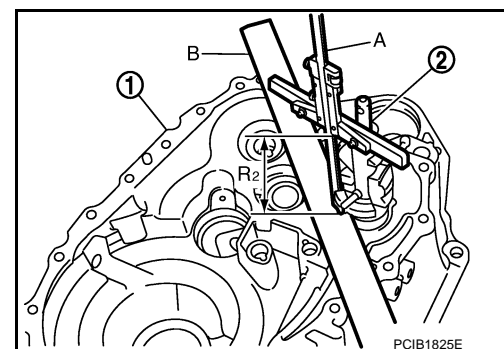

### Mainshaft End Play

# TRANSAXLE ASSEMBLY

< UNIT DISASSEMBLY AND ASSEMBLY >

[6MT: RS6F52H]

- When adjusting mainshaft end play, select adjusting shim (1) for mainshaft rear bearing (2). To select adjusting shim, measure clearance (M) between transaxle case (3) and dummy adjusting shim (4) on mainshaft rear bearing. Refer to [TM-141, "Available Adjusting Shims"](#).

- 5 : Snap ring
- 6 : Mainshaft

**CAUTION:**

**Only 1 adjusting shim can be selected.**

- Calculate dimension (P) (thickness of adjusting shim) using the following procedure to satisfy specification of end play for mainshaft rear bearing.

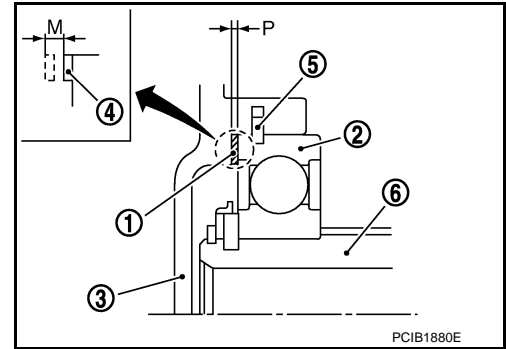

**End play** : Refer to [TM-141, "Available Adjusting Shims"](#).

**Dimension P = (M + N) - End play**

**P** : Thickness of adjusting shim

**M** : Distance between dummy adjusting shim on mainshaft rear bearing end face and transaxle case end face

**N\*** : Thickness of dummy adjusting shim

\*: Refer to the latest parts information to use a dummy adjusting shim of which part number is the thinnest in thickness. Refer to [TM-141, "Available Adjusting Shims"](#).

- Install transaxle case following the procedures below.
  - Temporarily install snap ring of mainshaft rear bearing into transaxle case.

**CAUTION:**

**Do not reuse snap ring.**

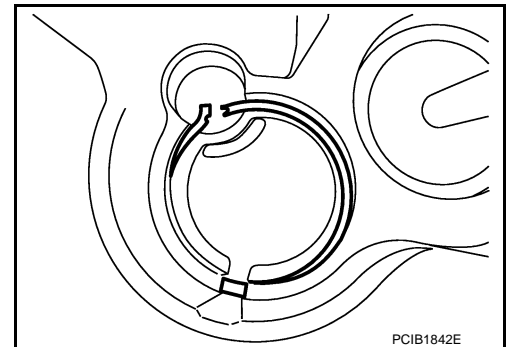

- Install dummy adjusting shim (1) to mainshaft assembly.

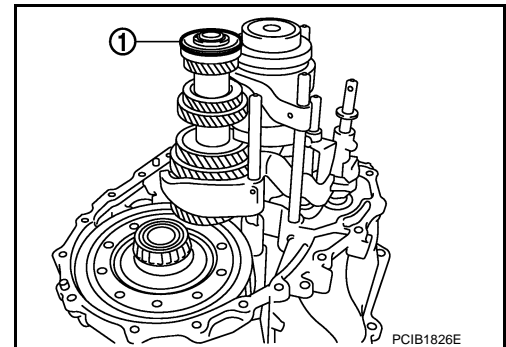

# TRANSAXLE ASSEMBLY

## < UNIT DISASSEMBLY AND ASSEMBLY >

[6MT: RS6F52H]

- c. With shifter lever A (1) held in the position shown, temporarily assemble transaxle case to clutch housing.

**CAUTION:**

**Do not damage striking rod oil seal.**

**NOTE:**

Make sure to hold shifter lever A in the position shown. Otherwise transaxle case cannot be installed to clutch housing.

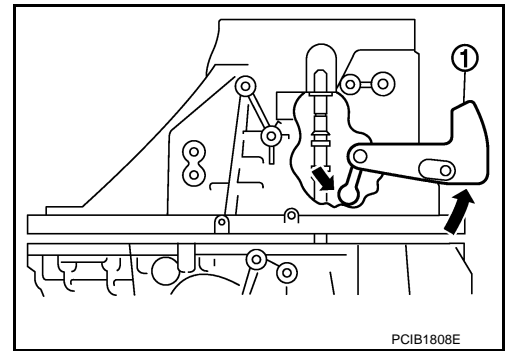

- d. While rotating shifter lever A (1) in the direction of the arrow shown, assemble transaxle case to clutch housing.

2 : shifter lever B

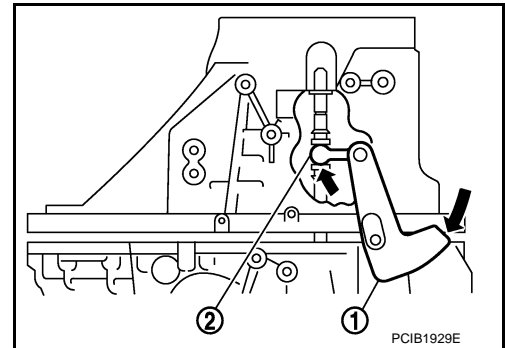

- e. Accessing from the bore plug hole, expand snap ring at mainshaft rear bearing so that the ring catches the periphery of mainshaft rear bearing.  
f. Temporarily tighten transaxle case bolts.

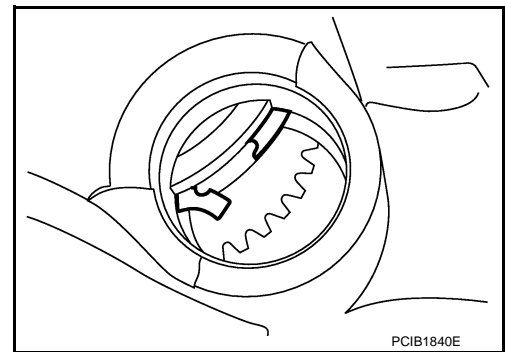

2. Shift the shifter lever A to 2nd gear position.

**NOTE:**

- The 2nd gear position is attained when shifter lever A (1) is in the position shown.

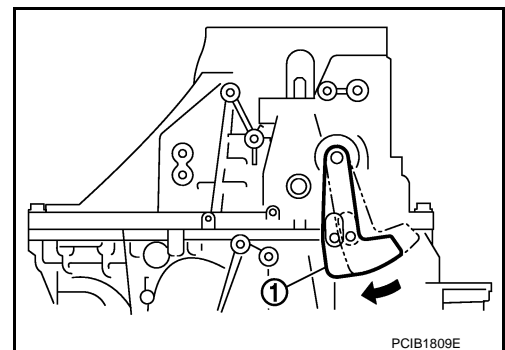

- When transaxle is shifted to the 2nd gear position, mainshaft assembly (1) is lifted.

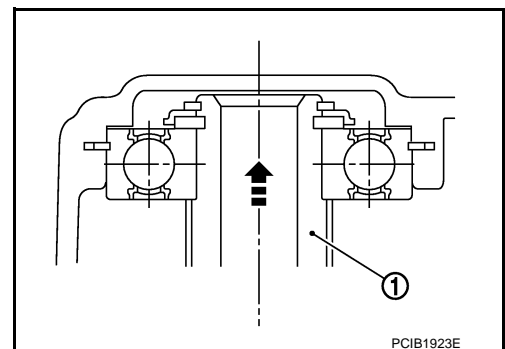

A  
B  
C  
TM  
E  
F  
G  
H  
I  
J  
K  
L  
M  
N  
O  
P

# TRANSAXLE ASSEMBLY

< UNIT DISASSEMBLY AND ASSEMBLY >

[6MT: RS6F52H]

3. Seat snap ring in the groove on mainshaft rear bearing. If snap ring is not seated in the groove on mainshaft rear bearing, remove transaxle case and repeat the procedure 1 from step c.
4. Shift the shifter lever A to 1st gear position, and then shift it to 2nd gear position. Repeat 3 times.

**NOTE:**

- The mainshaft rear bearing position will be stabilized by shifting between 1st gear position and 2nd gear position alternately.
- The 1st gear position is attained when shifter lever A (1) is in the position shown.

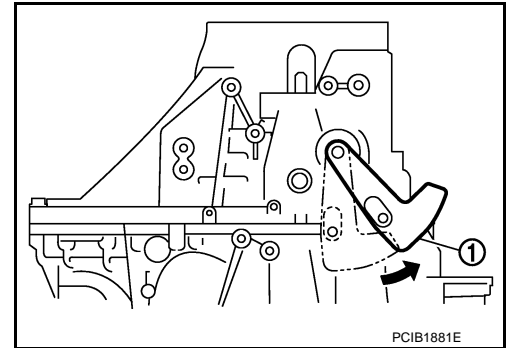

- When transaxle is shifted to the 1st gear position, mainshaft assembly (1) is declined.

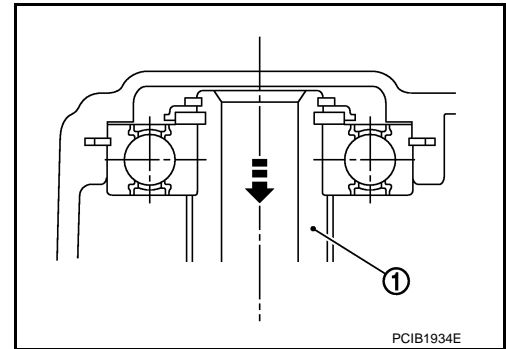

5. Set the dial indicator (A) to dummy adjusting shim (1) through the bore plug hole.

- 2 : Mainshaft rear bearing
- 3 : Snap ring

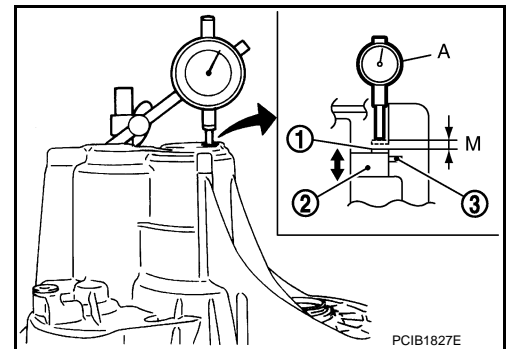

# TRANSAXLE ASSEMBLY

< UNIT DISASSEMBLY AND ASSEMBLY >

[6MT: RS6F52H]

- Shift the shifter lever A (1) to 2nd gear position (A), and then rotate it in the direction of the arrow (C) shown until it stops. Using this position as the reference point, measure the amount of movement when shifting shifter lever A to 1st gear position (B) and rotating it in the direction of the arrow (D) shown until it stops. This measurement is the (M) dimension.
- When measurement (M) is 0 - 0.06 mm (0 - 0.0024 in), adjustment terminates, and the dummy adjusting shim becomes regular adjusting shim. Select adjusting shim from the computed expressions when measurement (M) is over 0.06 mm (0.0024 in).

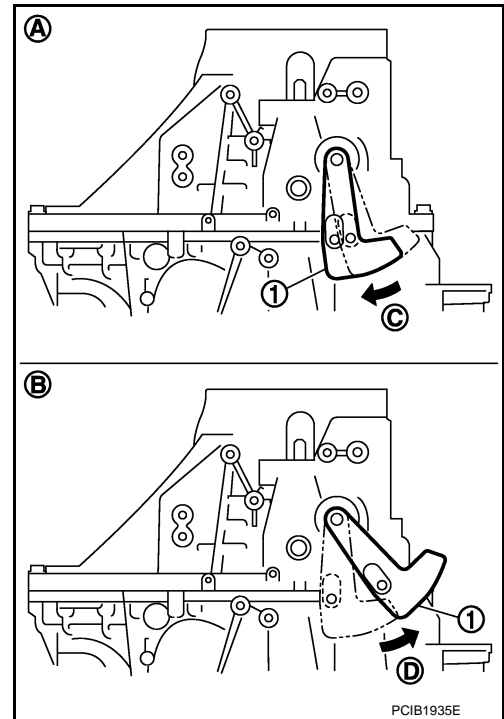

A  
B  
C  
TM  
E  
F  
G  
H  
I  
J  
K  
L  
M  
N  
O  
P

# INPUT SHAFT AND GEARS

< UNIT DISASSEMBLY AND ASSEMBLY >

[6MT: RS6F52H]

## INPUT SHAFT AND GEARS

Exploded View

INFOID:000000010291442

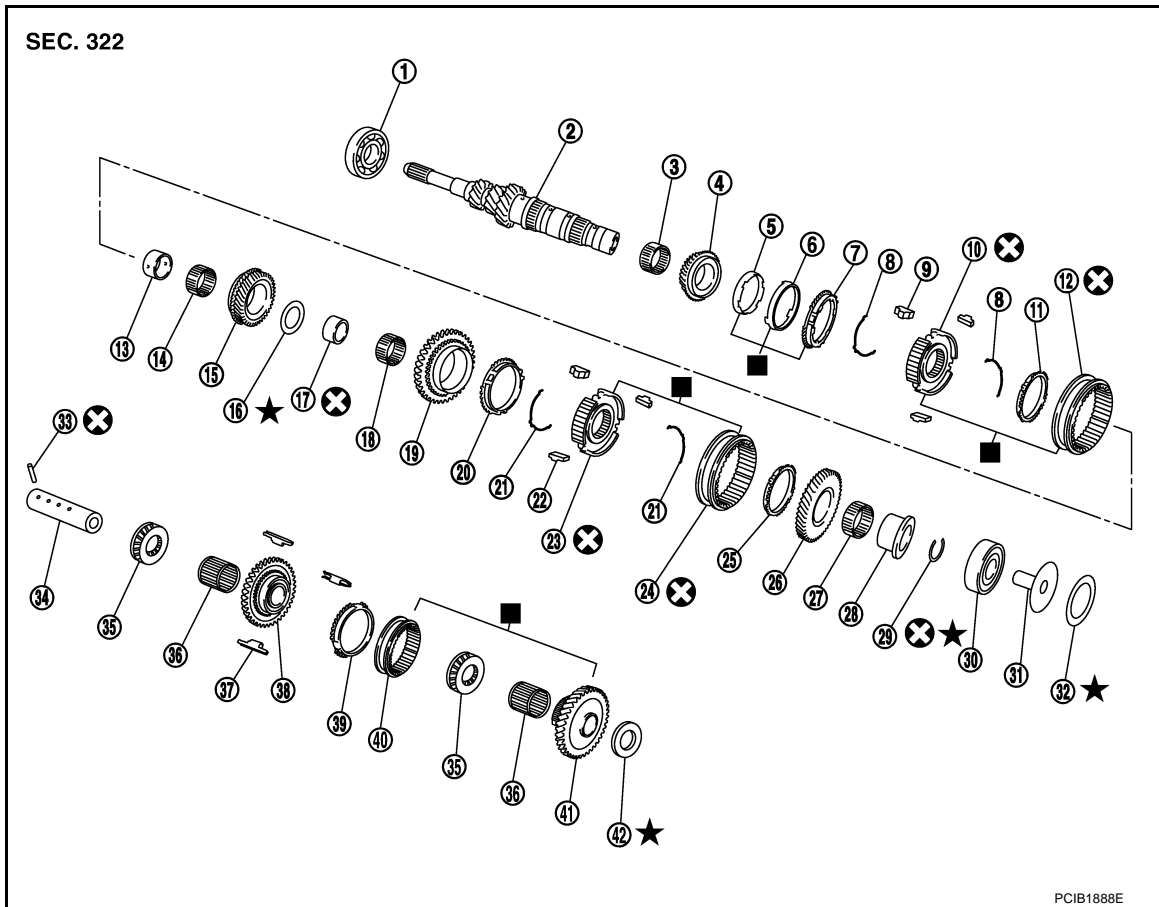

- |                              |   |                                       |
|------------------------------|---|---------------------------------------|
| 1. Input shaft front bearing | 2. Input shaft                              | 3. 3rd needle bearing                 |
| 4. 3rd input gear            | 5. 3rd inner baulk ring                     | 6. 3rd synchronizer cone              |
| 7. 3rd outer baulk ring      | 8. 3rd-4th spread spring                    | 9. 3rd-4th shifting insert            |
| 10. 3rd-4th synchronizer hub | 11. 4th baulk ring                          | 12. 3rd-4th coupling sleeve           |
| 13. 4th input gear bushing   | 14. 4th needle bearing                      | 15. 4th input gear                    |
| 16. Thrust washer            | 17. 5th input gear bushing                  | 18. 5th needle bearing                |
| 19. 5th input gear           | 20. 5th baulk ring                          | 21. 5th-6th spread spring             |
| 22. 5th-6th shifting insert  | 23. 5th-6th synchronizer hub                | 24. 5th-6th coupling sleeve           |
| 25. 6th baulk ring           | 26. 6th input gear                          | 27. 6th needle bearing                |
| 28. 6th input gear bushing   | 29. Snap ring                               | 30. Input shaft rear bearing          |
| 31. Oil channel              | 32. Input shaft rear bearing adjusting shim | 33. Retaining pin                     |
| 34. Reverse idler shaft      | 35. Thrust needle bearing                   | 36. Reverse idler gear needle bearing |
| 37. Reverse insert spring    | 38. Reverse idler gear (front)              | 39. Reverse baulk ring                |
| 40. Reverse coupling sleeve  | 41. Reverse idler gear (rear)               | 42. Reverse idler gear adjusting shim |

: Apply gear oil.

: Replace the parts as a set.

: Always replace after every disassembly.

: N·m (kg·m, ft·lb)



# INPUT SHAFT AND GEARS

< UNIT DISASSEMBLY AND ASSEMBLY >

[6MT: RS6F52H]

## Disassembly and Assembly

INFOID:000000010281901

### DISASSEMBLY

1. Before disassembling, measure end play for 3rd, 4th, 5th, and 6th input gears.

#### End play standard value

: Refer to [TM-139, "Gear End Play"](#).

2. Remove oil channel.

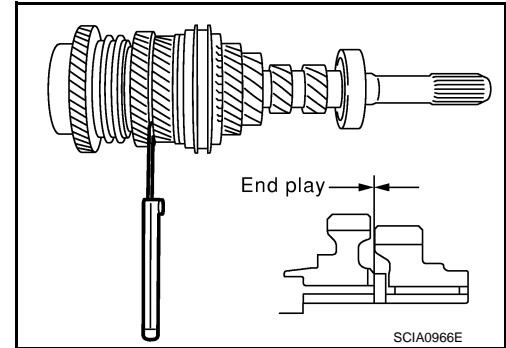

3. Press out input shaft rear bearing using Tool and a puller.

**Tool number** : ST33052000 ( — )

4. Remove snap ring.

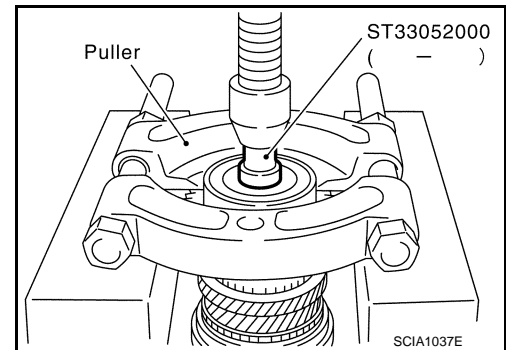

5. Press out 6th input gear, 6th needle bearing, 6th input gear bushing, 5th-6th synchronizer hub assembly, and 5th input gear using Tool (A) and a puller (B).

**Tool number** A: ST33052000 ( — )

6. Remove 5th needle bearing.

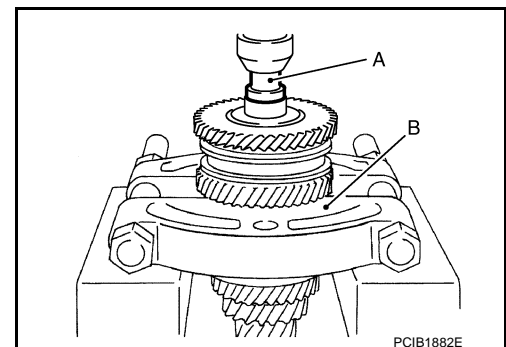

7. Press out 5th input gear bushing, thrust washer, 4th input gear, 4th needle bearing, 4th input gear bushing, 3rd-4th synchronizer hub assembly, and 3rd input gear using Tool and a puller.

**Tool number** : ST33052000 ( — )

8. Remove 3rd needle bearing.

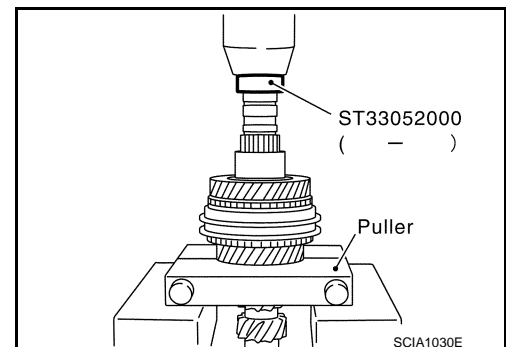

A  
B  
C  
TM  
E  
F  
G  
H  
I  
J  
K  
L  
M  
N  
O  
P

# INPUT SHAFT AND GEARS

< UNIT DISASSEMBLY AND ASSEMBLY >

[6MT: RS6F52H]

9. Press out input shaft front bearing using a puller.

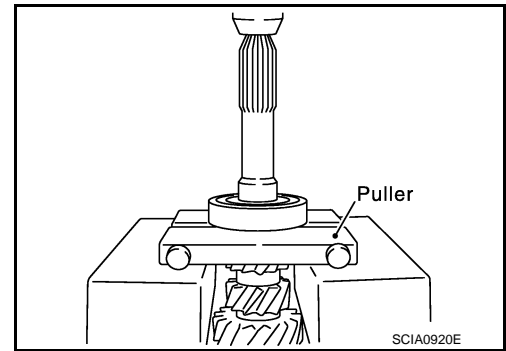

## INSPECTION AFTER DISASSEMBLY

### Input Shaft and Gears

Check items below. If necessary, replace them with new ones.

- Damage, peeling, dent, uneven wear, bending, etc. of shaft
- Excessive wear, damage, peeling, etc. of gears

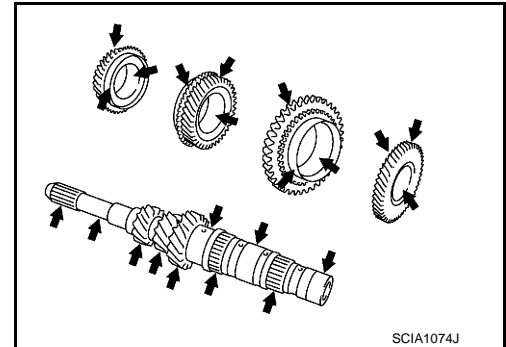

### Synchronizer

Check items below. If necessary, replace them with new ones.

- Damage and excessive wear of contact surfaces of coupling sleeve, synchronizer hub and shifting insert
- Coupling sleeve and synchronizer hub must move smoothly.

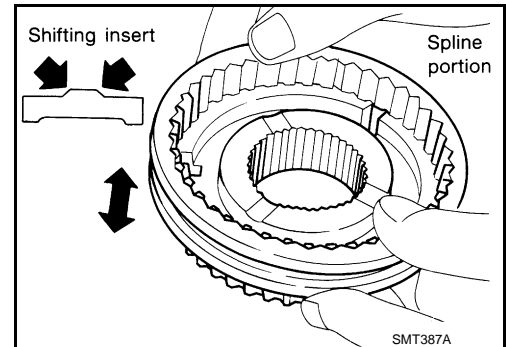

- If any crack, damage, or excessive wear is found on cam face of baulk ring or working face of insert, replace it.

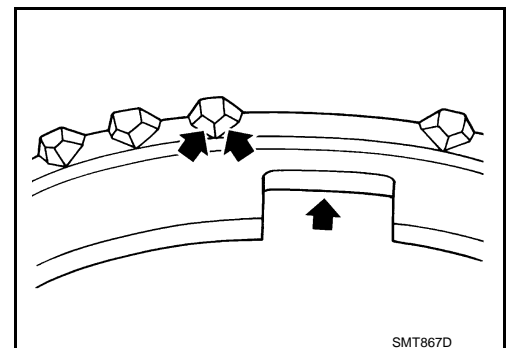

## BAULK RING CLEARANCE

- Single-cone synchronizer (4th, 5th, and 6th)

# INPUT SHAFT AND GEARS

< UNIT DISASSEMBLY AND ASSEMBLY >

[6MT: RS6F52H]

Push baulk ring on the cone and measure the clearance between baulk ring and cone. If measurement is below limit, replace it with a new one.

## Clearance

**Standard value** : Refer to [TM-139, "Baulk Ring Clearance"](#).

**Limit value** : Refer to [TM-139, "Baulk Ring Clearance"](#).

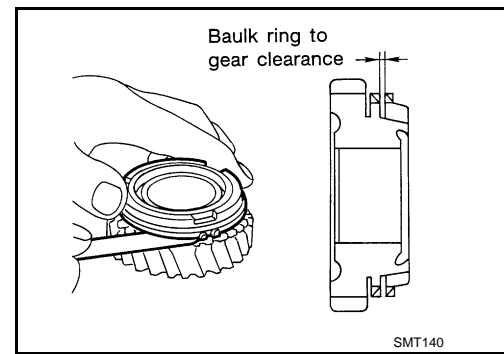

## • Double-cone synchronizer (3rd)

Check the clearance between outer baulk ring, synchronizer cone, and inner baulk ring as follows.

### CAUTION:

The clearances (A) and (B) are controlled with outer baulk ring, synchronizer cone, and inner baulk ring as a set. Replace them as a set if the clearances are outside the limit value.

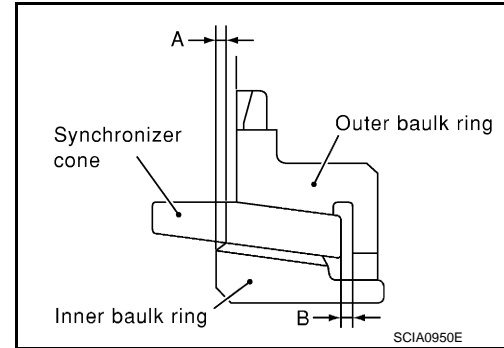

1. Measure the clearance (A) at 2 points or more diagonally opposite using a dial indicator. And then calculate mean value.

**Tool number** : **ST30031000 (J-22912-01)**

## Clearance (A)

**Standard value** : Refer to [TM-139, "Baulk Ring Clearance"](#).

**Limit value** : Refer to [TM-139, "Baulk Ring Clearance"](#).

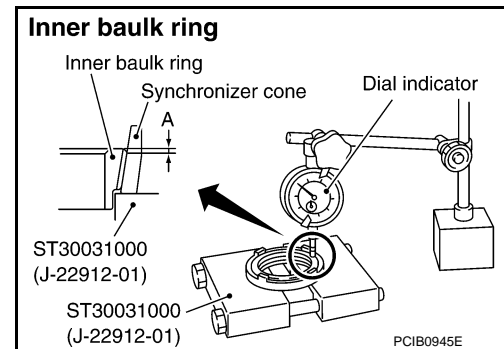

2. Measure the clearance (B) at 2 points or more diagonally opposite using a feeler gauge. And then calculate mean value.

## Clearance (B)

**Standard value** : Refer to [TM-139, "Baulk Ring Clearance"](#).

**Limit value** : Refer to [TM-139, "Baulk Ring Clearance"](#).

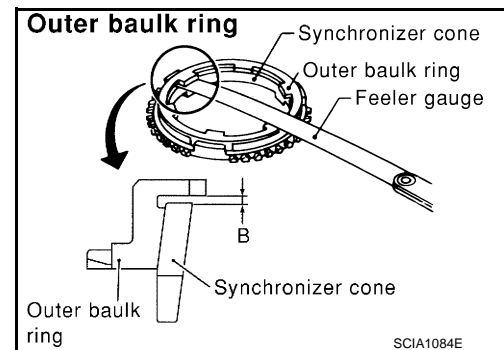

Bearing

# INPUT SHAFT AND GEARS

< UNIT DISASSEMBLY AND ASSEMBLY >

[6MT: RS6F52H]

Check items below. If necessary, replace them with new ones.

- Damage and rough rotation of bearing

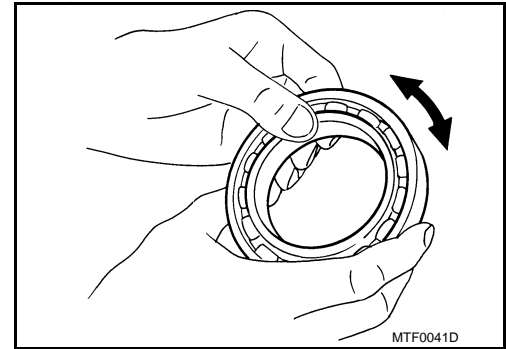

## ASSEMBLY

1. Install 3rd needle bearing to input shaft.
2. Install 3rd input gear, 3rd inner baulk ring, 3rd synchronizer cone, and 3rd outer baulk ring to input shaft.  
**CAUTION:**  
**Replace 3rd inner baulk ring, 3rd synchronizer cone, and 3rd outer baulk ring as a set.**
3. Install 3rd-4th spread springs, 3rd-4th shifting inserts, and 3rd-4th synchronizer hub onto 3rd-4th coupling sleeve.

**CAUTION:**

- Be careful with orientation of 3rd-4th synchronizer hub.
- Do not reuse 3rd-4th synchronizer hub and 3rd-4th coupling sleeve.
- Replace 3rd-4th synchronizer hub and 3rd-4th coupling sleeve as a set.

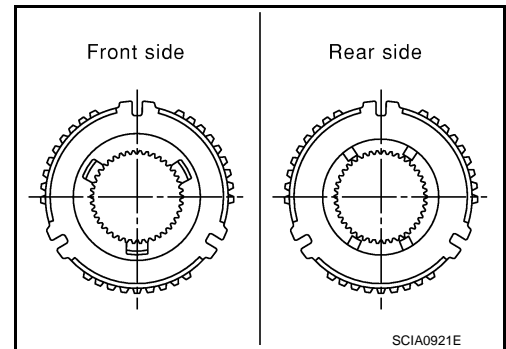

- Be careful with orientation of 3rd-4th coupling sleeve.

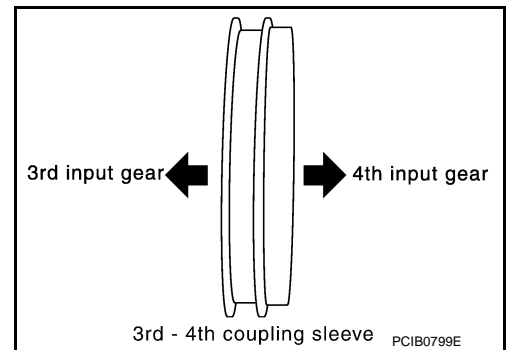

- Be sure not to hook center projection of 2 spread springs on same shifting insert.

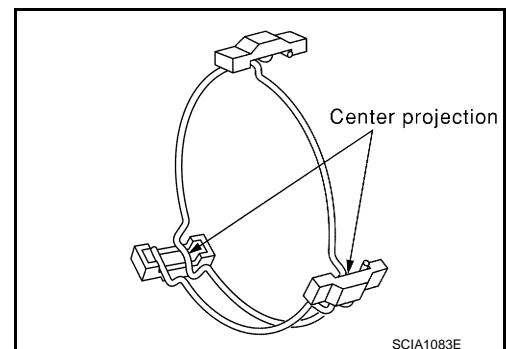

# INPUT SHAFT AND GEARS

< UNIT DISASSEMBLY AND ASSEMBLY >

[6MT: RS6F52H]

4. Press in 3rd-4th synchronizer hub assembly using Tool.

**Tool number** : KV40105710 ( — )

**CAUTION:**

Align grooves of 3rd-4th shifting insert and 3rd outer baulk ring.

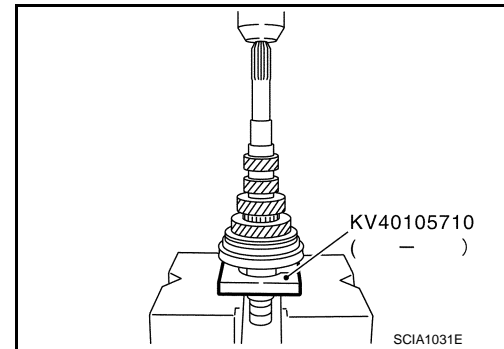

5. Press in 4th input gear bushing using Tool.

**Tool number** : KV40105710 ( — )

6. Install 4th baulk ring.  
7. Install 4th needle bearing and 4th input gear to input shaft.

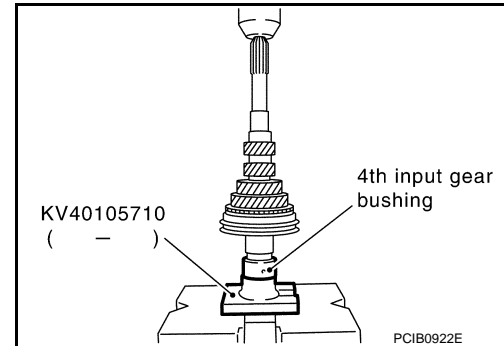

8. Select thrust washer so that dimension "C2" satisfies the standard value below. Then install thrust washer onto input shaft. Refer to [TM-140, "Available Thrust Washer"](#).

**Standard value for dimension "C2"**

: Refer to [TM-140, "Available Thrust Washer"](#).

**CAUTION:**

Only one thrust washer can be selected.

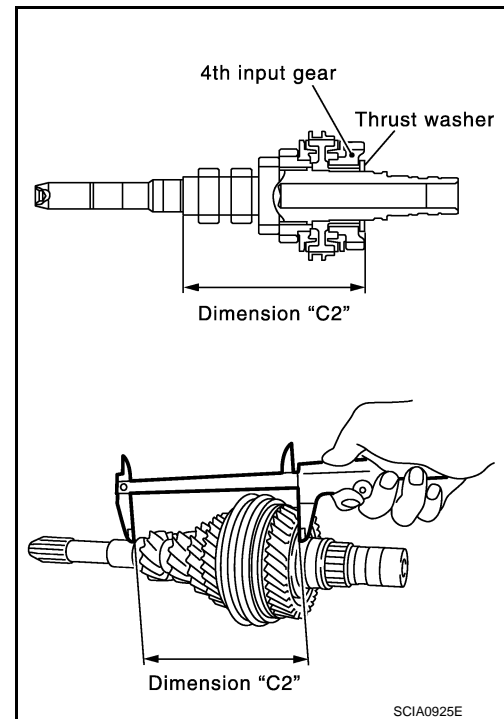

9. Press in 5th input gear bushing using Tool.

**Tool number** : KV40105710 ( — )

**CAUTION:**

Do not reuse 5th input gear bushing.

10. Install 5th needle bearing and 5th input gear to input shaft.  
11. Install 5th baulk ring.

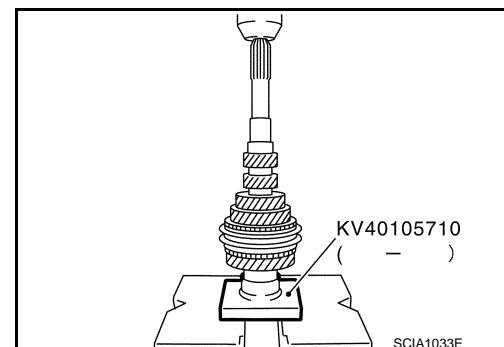

A  
B  
C  
TM  
E  
F  
G  
H  
I  
J  
K  
L  
M  
N  
O  
P

# INPUT SHAFT AND GEARS

< UNIT DISASSEMBLY AND ASSEMBLY >

[6MT: RS6F52H]

12. Install 5th-6th synchronizer hub, 5th-6th spread springs, and 5th-6th shifting inserts onto 5th-6th coupling sleeve.

**CAUTION:**

- Be careful with orientation of 5th-6th synchronizer hub.

A : Front side

B : Rear side

- Do not reuse 5th-6th synchronizer hub and 5th-6th coupling sleeve.
- Replace 5th-6th synchronizer hub and 5th-6th coupling sleeve as a set.

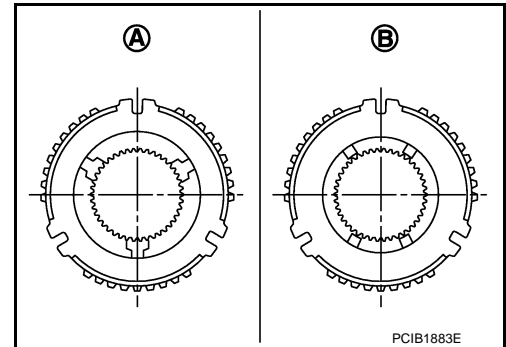

- Be careful with orientation of 5th-6th coupling sleeve.

A : 5th input gear side

B : 6th input gear side

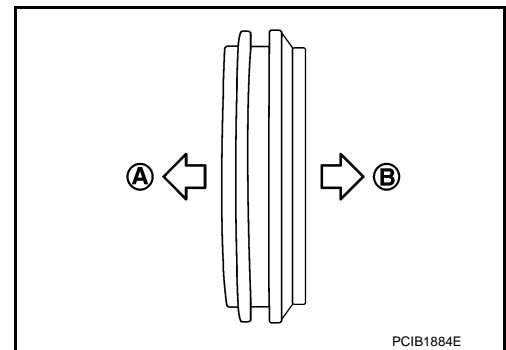

- Be sure not to hook center projection of 2 spread springs on same shifting insert.

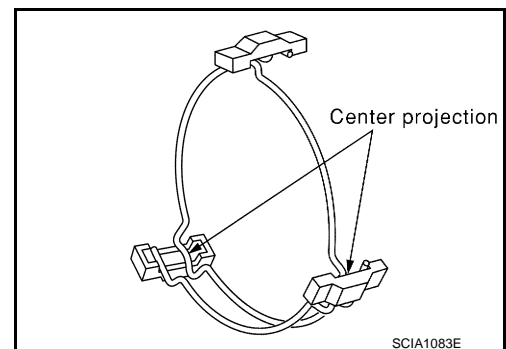

13. Press in 5th-6th synchronizer hub assembly using Tool.

**Tool number** : KV40105710 ( — )

**CAUTION:**

Align grooves of 5th-6th shifting insert and 5th baulk ring.

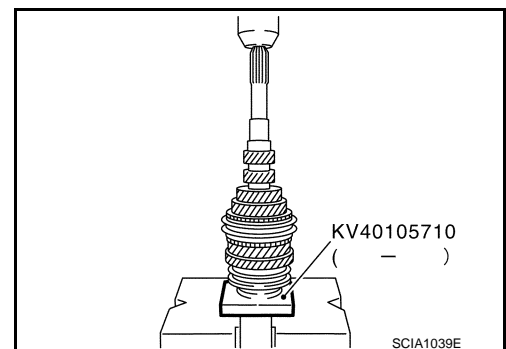

# INPUT SHAFT AND GEARS

< UNIT DISASSEMBLY AND ASSEMBLY >

[6MT: RS6F52H]

14. Install 6th needle bearing, 6th input gear, 6th baulk ring onto 6th input gear bushing and then press in 6th input gear bushing onto input shaft using Tool.

**Tool number** : ST33200000 (J-26082)

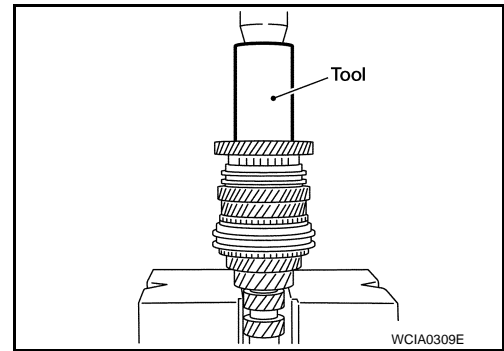

15. Install snap ring onto input shaft and make sure that end play (gap between snap ring and groove) of 6th input gear bushing satisfies the standard value.

**End play standard value**

:Refer to [TM-139, "Available Snap Rings"](#).

- If measurement is outside the standard range, select snap ring. Refer to [TM-139, "Available Snap Rings"](#).

**CAUTION:**

**Do not reuse snap ring.**

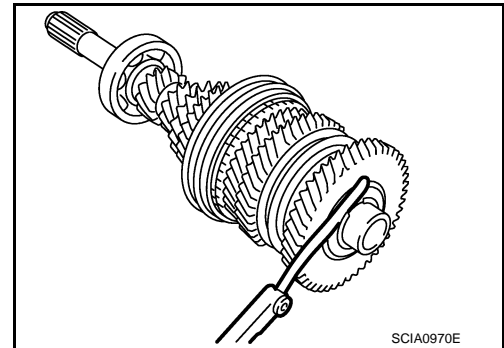

16. Press in input shaft rear bearing using Tool.

**Tool number** : ST30901000 (J-26010-01)

**CAUTION:**

**Install input shaft rear bearing with its brown surface facing the 6th input gear side.**

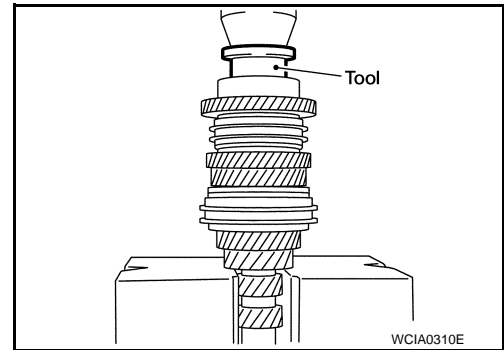

17. Press in input shaft front bearing using Tools.

**Tool number** **A:** ST33052000 ( — )

**B:** ST30032000 (J-26010-01)

18. Install oil channel onto input shaft.

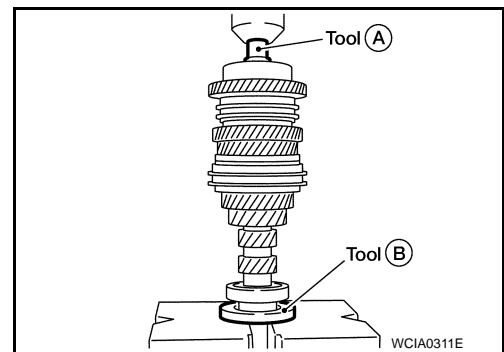

19. Check end play of 3rd, 4th, 5th, and 6th input gears.

**End play standard value**

: Refer to [TM-139, "Gear End Play"](#).

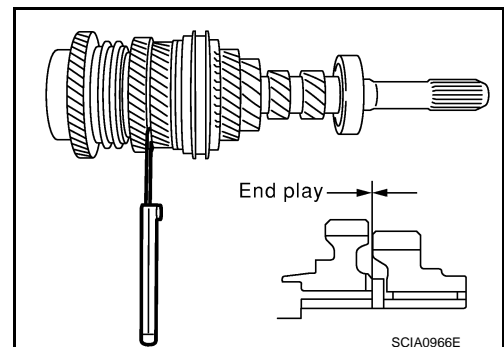

A  
B  
C  
TM  
E  
F  
G  
H  
I  
J  
K  
L  
M  
N  
O  
P

# MAINSHAFT AND GEARS

< UNIT DISASSEMBLY AND ASSEMBLY >

[6MT: RS6F52H]

## MAINSHAFT AND GEARS

Exploded View

INFOID:000000010291443

### MAINSHAFT AND GEARS

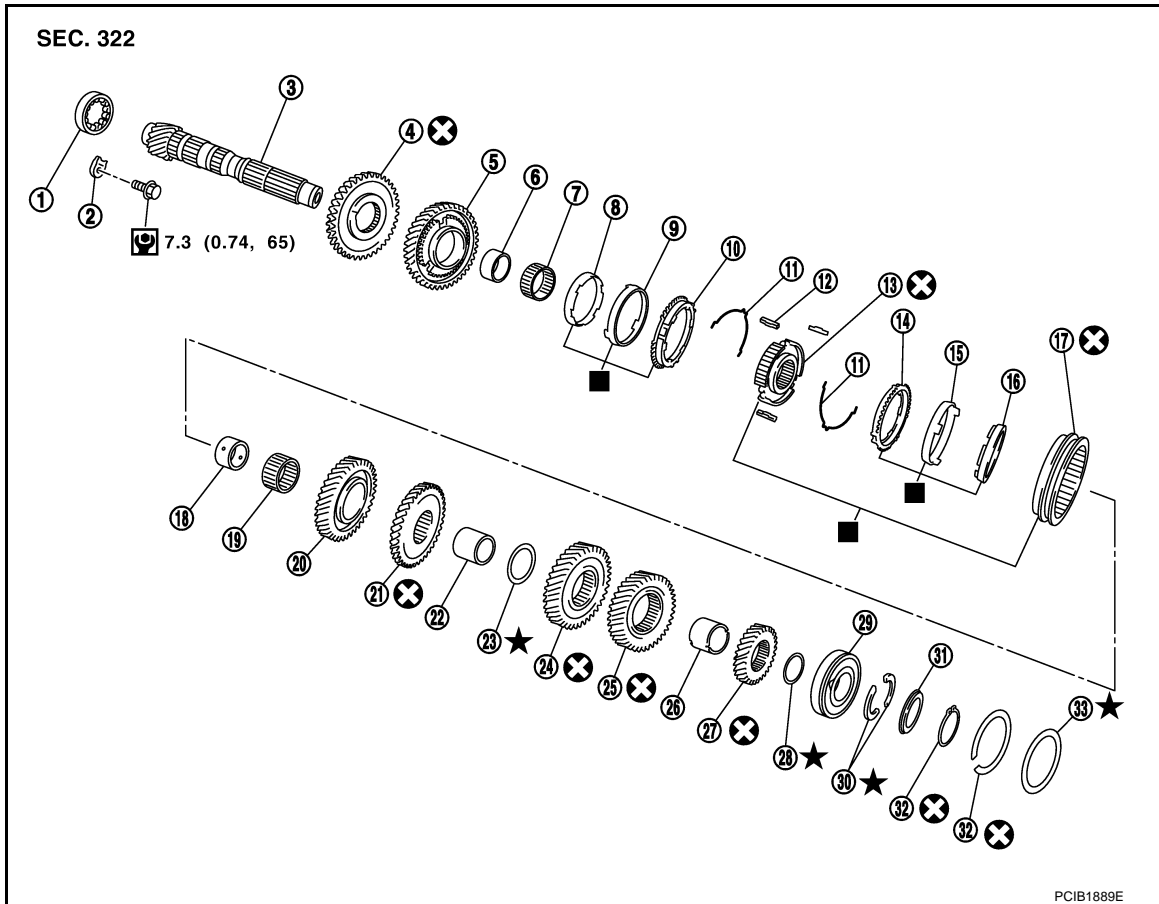

- |                                  |                                  |   |
|----------------------------------|----------------------------------|---|
| 1. Mainshaft front bearing       | 2. Mainshaft bearing retainer    | 3. Mainshaft                              |
| 4. Reverse main gear             | 5. 1st main gear                 | 6. 1st main gear bushing                  |
| 7. 1st needle bearing            | 8. 1st inner baulk ring          | 9. 1st synchronizer cone                  |
| 10. 1st outer baulk ring         | 11. 1st-2nd spread spring        | 12. 1st-2nd shifting insert               |
| 13. 1st-2nd synchronizer hub     | 14. 2nd outer baulk ring         | 15. 2nd synchronizer cone                 |
| 16. 2nd inner baulk ring         | 17. 1st-2nd coupling sleeve      | 18. 2nd main gear bushing                 |
| 19. 2nd needle bearing           | 20. 2nd main gear                | 21. 3rd main gear                         |
| 22. 3rd-4th mainshaft spacer     | 23. 4th main gear adjusting shim | 24. 4th main gear                         |
| 25. 5th main gear                | 26. 5th-6th mainshaft spacer     | 27. 6th main gear                         |
| 28. 6th main gear adjusting shim | 29. Mainshaft rear bearing       | 30. Mainshaft C-ring                      |
| 31. C-ring holder                | 32. Snap ring                    | 33. Mainshaft rear bearing adjusting shim |

: Apply gear oil.

: Replace the parts as a set.

: Always replace after every disassembly.

: N·m (kg·m, ft·lb)

## Disassembly and Assembly

INFOID:000000010281902

### DISASSEMBLY

Revision: 2013 October

TM-120

2014 JUKE



# MAINSHAFT AND GEARS

< UNIT DISASSEMBLY AND ASSEMBLY >

[6MT: RS6F52H]

1. Before disassembling, measure the end play of 1st and 2nd main gears.

**End play standard value**

**: Refer to [TM-139](#), "Gear End Play".**

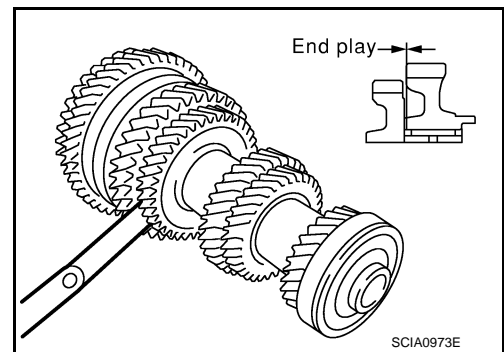

2. Remove snap ring.
3. Remove C-ring holder and then remove mainshaft C-rings.

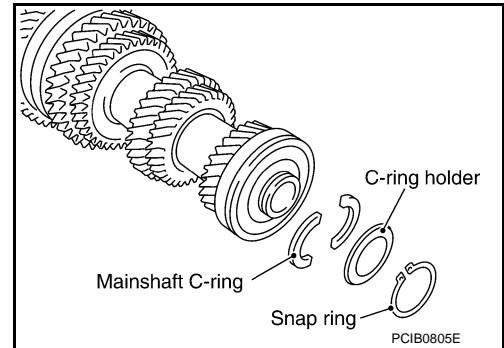

4. Press out mainshaft rear bearing, 6th main gear adjusting shim, and 6th main gear using Tool and a puller.

**Tool number : ST33052000 ( — )**

5. Remove 5th-6th mainshaft spacer.

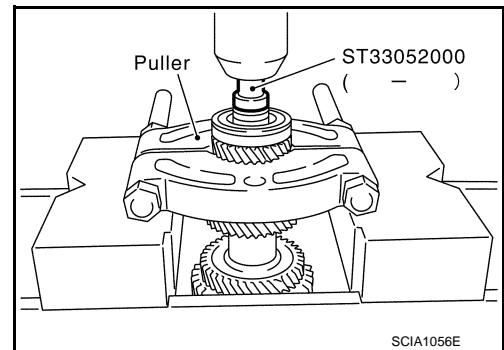

6. Press out 4th main gear and 5th main gear using Tool and a puller.

**Tool number : ST33052000 ( — )**

7. Remove 4th main gear adjusting shim.
8. Remove 3rd-4th mainshaft spacer.

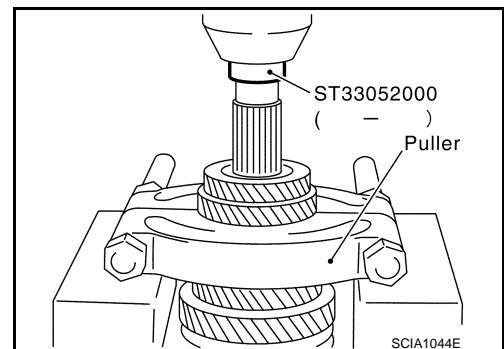

9. Press out 3rd main gear and 2nd main gear using Tool (A) and a puller (B).

**Tool number A: KV40105020 ( — )**

10. Remove 2nd needle bearing.

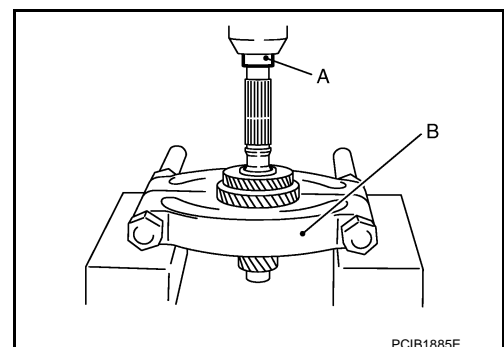

A  
B  
C  
TM  
E  
F  
G  
H  
I  
J  
K  
L  
M  
N  
O  
P

# MAINSHAFT AND GEARS

< UNIT DISASSEMBLY AND ASSEMBLY >

[6MT: RS6F52H]

11. Press out 2nd main gear bushing, 1st-2nd synchronizer hub assembly, 1st main gear, 1st needle bearing, 1st main gear bushing, and reverse main gear using Tool (A).

**Tool number**      **A: KV40105020 ( — )**

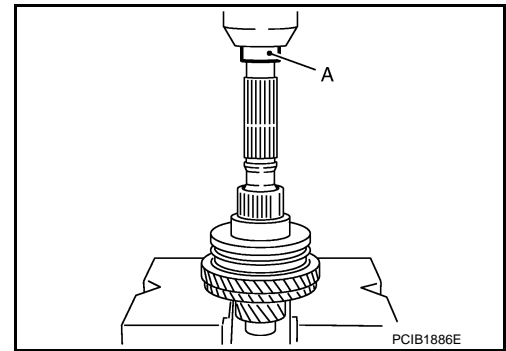

## INSPECTION AFTER DISASSEMBLY

### Mainshaft and Gears

Check items below. If necessary, replace them with new ones.

- Damage, peeling, dent, uneven wear, bending, and other non-standard conditions of the shaft.
- Excessive wear, damage, peeling, and other non-standard conditions of the gears.

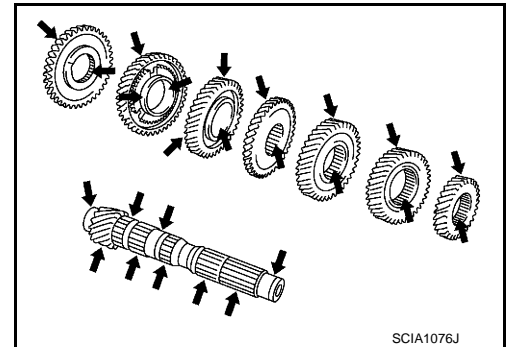

### Synchronizer

Check items below. If necessary, replace them with new ones.

- Damage and unusual wear on contact surfaces of coupling sleeve, synchronizer hub and shifting insert.
- Coupling sleeve and synchronizer hub must move smoothly.

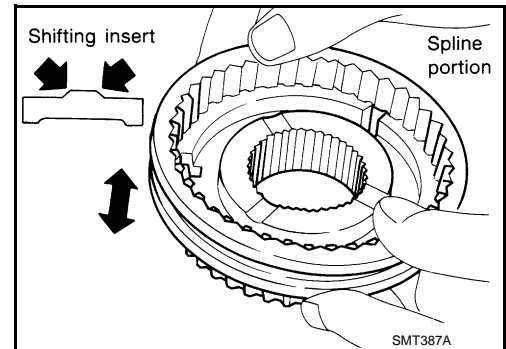

- If any crack, damage, or excessive wear is found on cam face of baulk ring or working face of insert, replace it.

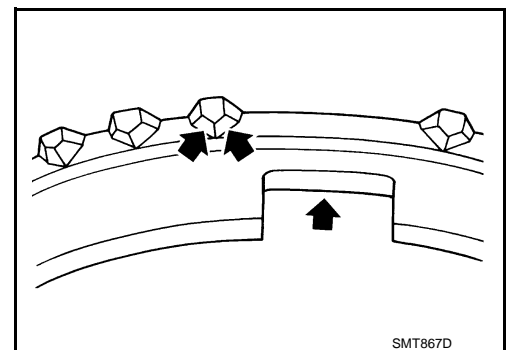

## BAULK RING CLEARANCE

Triple-cone synchronizer (1st and 2nd)

# MAINSHAFT AND GEARS

< UNIT DISASSEMBLY AND ASSEMBLY >

[6MT: RS6F52H]

- Check the clearance between outer baulk ring, synchronizer cone, and inner baulk ring as follows.

**CAUTION:**

The clearances (A), B, and (C) are controlled with outer baulk ring, synchronizer cone, and inner baulk ring as a set. Replace them as a set if the clearances are outside the limit value.

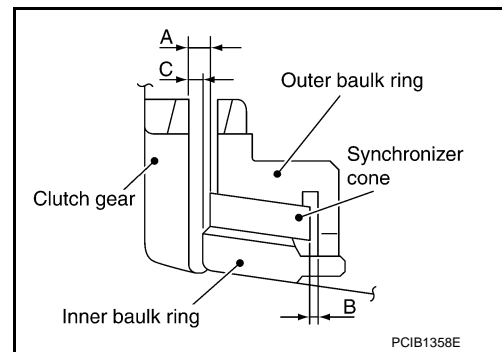

1. Measure the clearance (A) at 2 points or more diagonally opposite using a feeler gauge when pressing baulk ring toward clutch gear taper cone. And then calculate mean value.

**Clearance (A)**

**Standard value** : Refer to [TM-139, "Baulk Ring Clearance"](#).

**Limit value** : Refer to [TM-139, "Baulk Ring Clearance"](#).

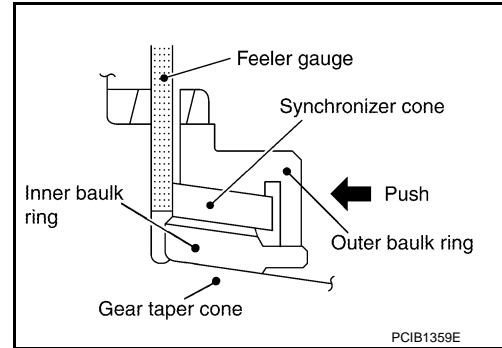

2. Measure the clearance (B) at 2 points or more diagonally opposite using a feeler gauge. And then calculate mean value.

**Clearance (B)**

**Standard value** : Refer to [TM-139, "Baulk Ring Clearance"](#).

**Limit value** : Refer to [TM-139, "Baulk Ring Clearance"](#).

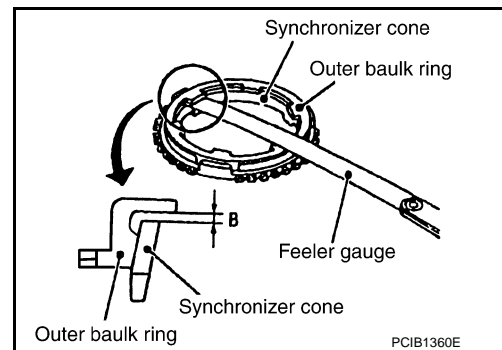

3. Measure the clearance (C) at 2 points or more diagonally opposite using a feeler gauge when pressing baulk ring toward clutch gear taper cone. And then calculate mean value.

**Clearance (C)**

**Standard value** : Refer to [TM-139, "Baulk Ring Clearance"](#).

**Limit value** : Refer to [TM-139, "Baulk Ring Clearance"](#).

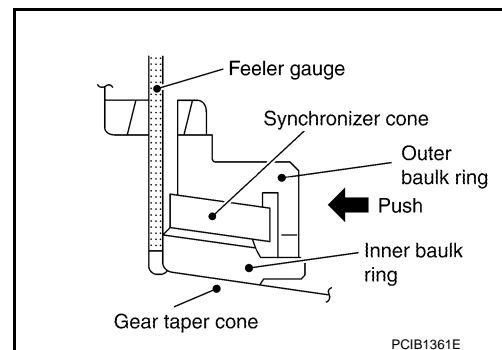

Bearing

# MAINSHAFT AND GEARS

< UNIT DISASSEMBLY AND ASSEMBLY >

[6MT: RS6F52H]

Check items below. If necessary, replace them with new ones.

- Damage and rough rotation of bearing

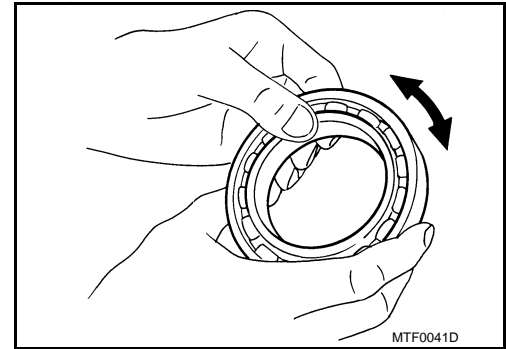

## ASSEMBLY

1. Press in reverse main gear using Tools.

**Tool number** : KV40101630 (J-35870)  
: ST35321000 ( — )  
: ST38220000 ( — )

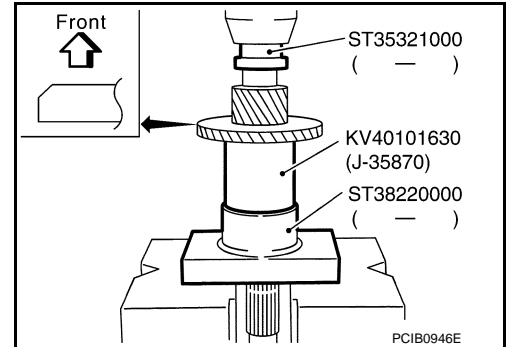

### CAUTION:

- Be careful with orientation of reverse main gear.
- Do not reuse reverse main gear.

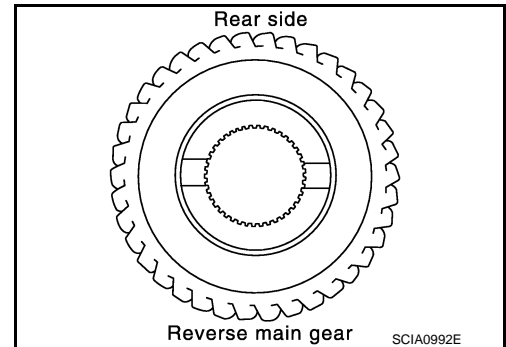

2. Press in 1st main gear bushing using Tools.

**Tool number** : KV38102510 ( — )  
: ST35321000 ( — )  
: ST38220000 ( — )

3. Install 1st needle bearing and then 1st main gear.

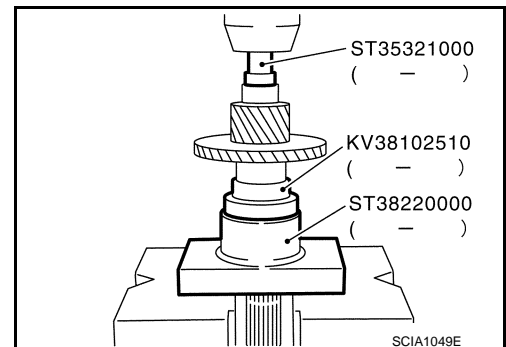

4. Install 1st-2nd spread springs, 1st-2nd shifting inserts, and 1st-2nd synchronizer hub onto 1st-2nd coupling sleeve.

### CAUTION:

# MAINSHAFT AND GEARS

< UNIT DISASSEMBLY AND ASSEMBLY >

[6MT: RS6F52H]

- Be careful with orientation of 1st-2nd synchronizer hub.
- Do not reuse 1st-2nd synchronizer hub and 1st-2nd coupling sleeve.
- Replace 1st-2nd synchronizer hub and 1st-2nd coupling sleeve as a set.

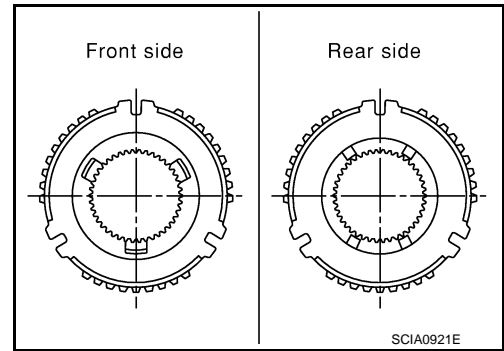

- Be careful with orientation of 1st-2nd coupling sleeve.

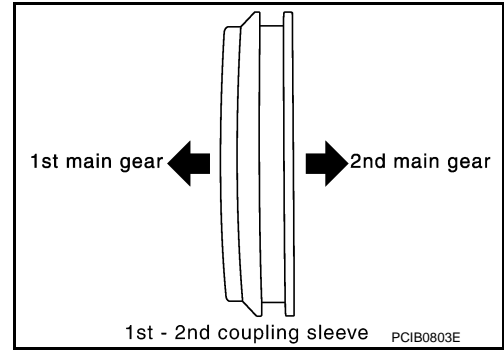

- Be sure not to hook center projection of 2 spread springs on same 1st-2nd shifting insert.

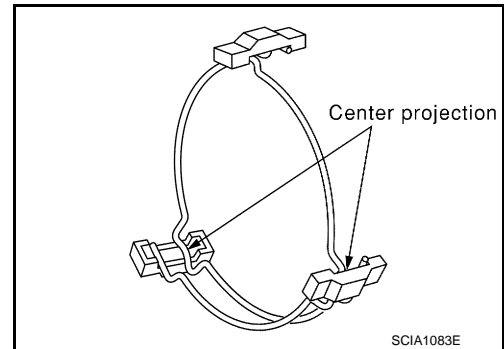

5. Install 1st inner baulk ring, 1st synchronizer cone, and 1st outer baulk ring onto mainshaft and then press in 1st-2nd synchronizer hub assembly onto mainshaft using Tools.

**Tool number** : KV40101630 (J-35870)  
 : ST35321000 ( — )  
 : ST38220000 ( — )

**CAUTION:**

- Outer baulk ring, synchronizer cone, and inner baulk ring on 2nd gear-side must have been removed.
- Be careful with orientation of coupling sleeve.
- Replace 1st inner baulk ring, 1st synchronizer cone, and 1st outer baulk ring as a set.

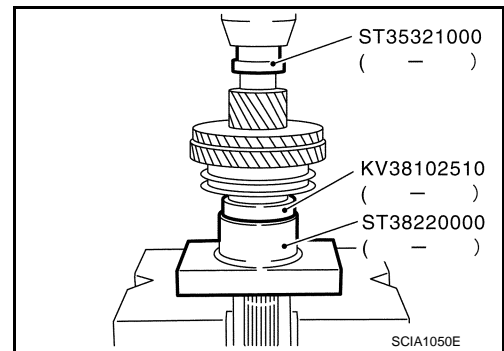

A  
B  
C  
TM  
E  
F  
G  
H  
I  
J  
K  
L  
M  
N  
O  
P

# MAINSHAFT AND GEARS

< UNIT DISASSEMBLY AND ASSEMBLY >

[6MT: RS6F52H]

6. Press in 2nd main gear bushing using Tools.

**Tool number** : KV40105710 ( — )  
 : ST35321000 ( — )

7. Install 2nd outer baulk ring, 2nd synchronizer cone, and 2nd inner baulk ring.

**CAUTION:**

**Replace 2nd outer baulk ring, 2nd synchronizer cone, and 2nd inner baulk ring as a set.**

8. Install 2nd needle bearing and 2nd main gear.

9. Press in 3rd main gear using Tools.

**Tool number** : KV40105710 ( — )  
 : ST35321000 ( — )

**CAUTION:**

- Be careful with orientation of 3rd main gear.
- Do not reuse 3rd main gear.

10. Install 3rd-4th mainshaft spacer.

11. Select 4th main gear adjusting shim so that dimension "C1" satisfies the standard value below and install 4th main gear adjusting shim onto mainshaft. Refer to [TM-141, "Available Adjusting Shims"](#).

**Standard value for dimension "C1"**

: Refer to [TM-141, "Available Adjusting Shims"](#).

**CAUTION:**

**Only one adjusting shim can be selected.**

12. Press in 4th main gear using Tools.

**Tool number** : ST33200000 (J-26082)  
 : ST30901000 (J-26010-01)

**CAUTION:**

- Be careful with orientation of 4th main gear.
- Do not reuse 4th main gear.

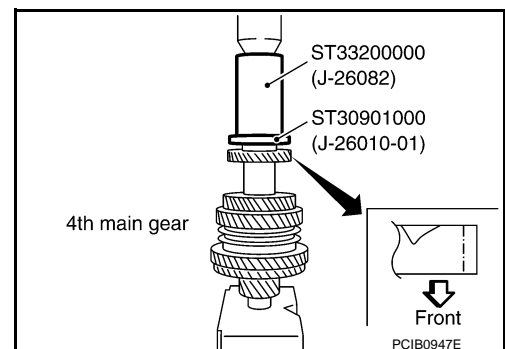
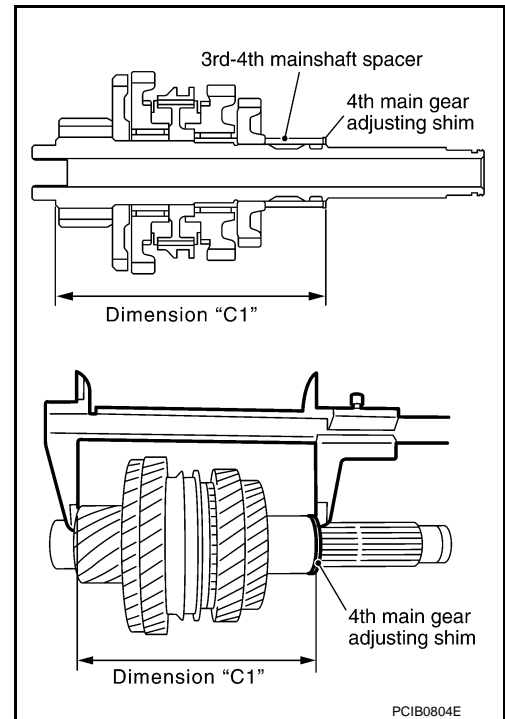
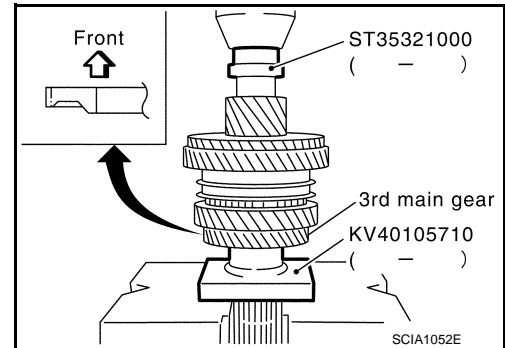
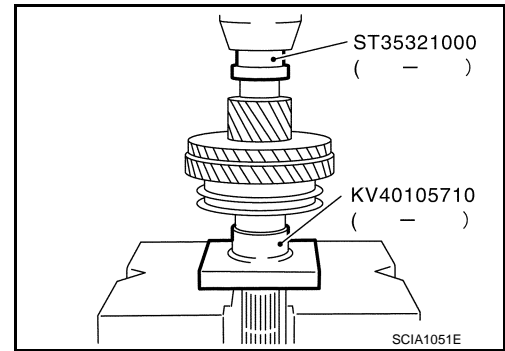

# MAINSHAFT AND GEARS

< UNIT DISASSEMBLY AND ASSEMBLY >

[6MT: RS6F52H]

13. Press in 5th main gear using Tools.

**Tool number** : ST33200000 (J-26082)  
: ST30901000 (J-26010-01)

**CAUTION:**

- Be careful with orientation of 5th main gear.
- Do not reuse 5th main gear.

14. Install 5th-6th mainshaft spacer.

15. Press in 6th main gear using Tools (A), (B).

**Tool number** A: ST33200000 (J-26082)  
B: ST30901000 (J-26010-01)

**CAUTION:**

Do not reuse 6th main gear.

16. Select 6th main gear adjusting shim and then install it onto mainshaft.

- Calculate thickness (S) of 6th main gear adjusting shim following the procedure below so that end play dimension between 6th main gear and mainshaft rear bearing becomes the dimension shown below. Refer to [TM-141, "Available Adjusting Shims"](#).

**End play** :Refer to [TM-141, "Available Adjusting Shims"](#).

**Dimension S = (S<sub>1</sub> - S<sub>2</sub>) - End play**

**S** : Thickness of adjusting shim

**S<sub>1</sub>** : Dimension from mainshaft standard face to mainshaft rear bearing press-fit end face

**S<sub>2</sub>** : Dimension from mainshaft standard face to 6th main gear end face

**CAUTION:**

Only one adjusting shim can be selected.

- Measure dimension (S<sub>1</sub>) and (S<sub>2</sub>) using a height gauge (A) and pick tester (B).
- Install selected 6th main gear adjusting shim to mainshaft.

17. Press in mainshaft rear bearing using Tools.

**Tool number** A: ST30720000 (J-25405)  
B: ST30901000 (J-26010-01)

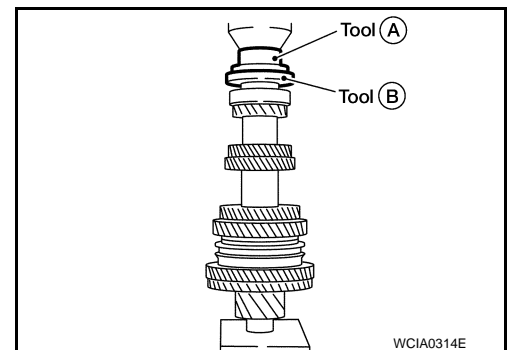
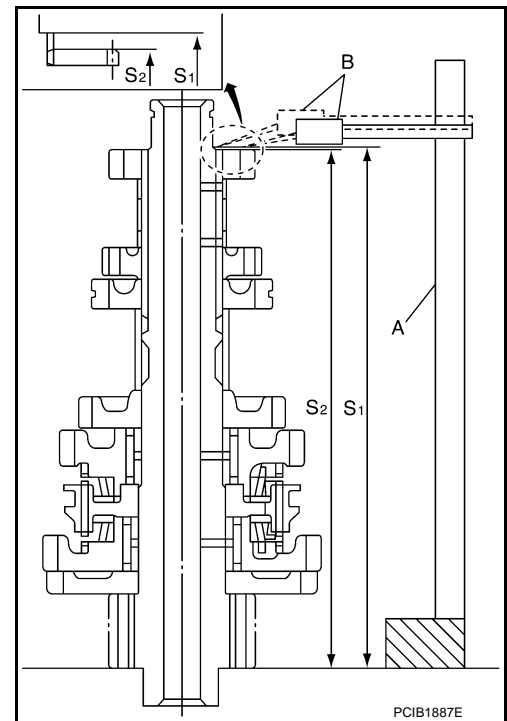
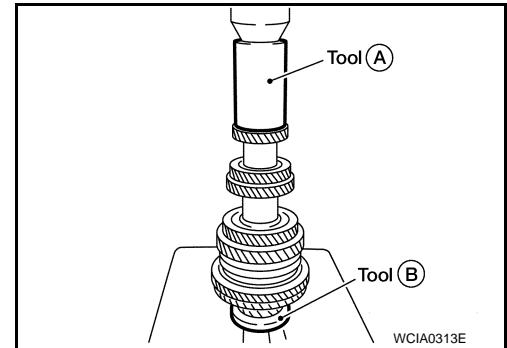
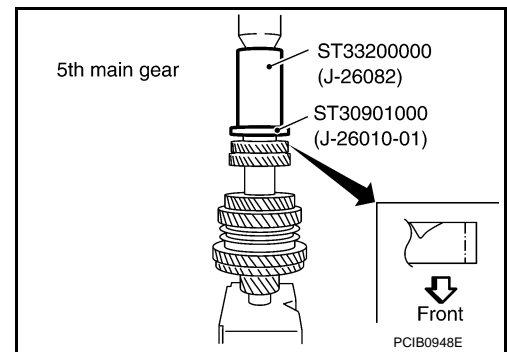

A  
B  
C  
TM  
E  
F  
G  
H  
I  
J  
K  
L  
M  
N  
O  
P

# MAINSHAFT AND GEARS

< UNIT DISASSEMBLY AND ASSEMBLY >

[6MT: RS6F52H]

18. Install mainshaft C-rings onto mainshaft and check that end play of mainshaft rear bearing satisfies the standard value.

**End play standard value**

: Refer to [TM-140, "Available C-Rings"](#).

- If measurement is outside the standard range, reselect mainshaft C-rings. Refer to [TM-140, "Available C-Rings"](#).

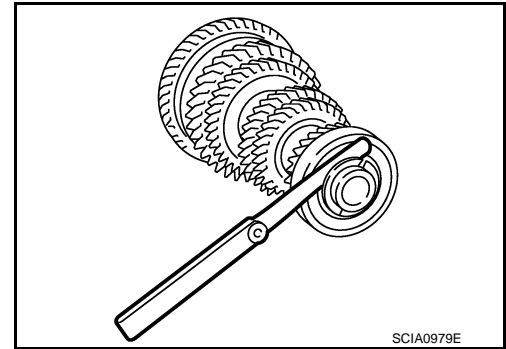

19. Install C-ring holder and then install snap ring.

**CAUTION:**

**Do not reuse snap ring.**

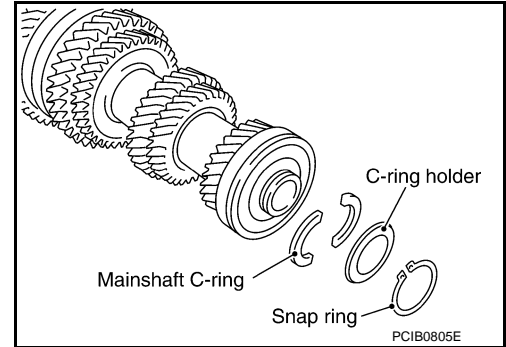

20. Check end play of 1st and 2nd main gears.

**End play standard value**

: Refer to [TM-139, "Gear End Play"](#).

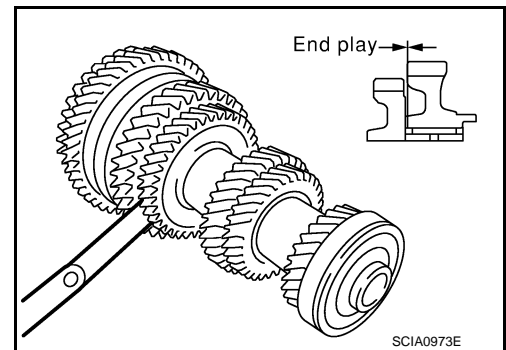



# REVERSE IDLER SHAFT AND GEARS

< UNIT DISASSEMBLY AND ASSEMBLY >

[6MT: RS6F52H]

## REVERSE IDLER SHAFT AND GEARS

### Disassembly and Assembly

INFOID:000000010281903

#### DISASSEMBLY

1. Remove reverse idler gear (rear), reverse coupling sleeve, and reverse insert springs simultaneously.
2. Remove reverse idler gear needle bearing.
3. Remove thrust needle bearing.
4. Remove reverse baulk ring.
5. Remove reverse idler gear (front).
6. Remove reverse idler gear needle bearing.
7. Remove thrust needle bearing.
8. Remove retaining pin from reverse idler shaft.

#### INSPECTION AFTER DISASSEMBLY

##### Reverse Idler Shaft and Gears

Check items below. If necessary, replace them with new ones.

- Damage, peeling, dent, uneven wear, bending, and other non-standard conditions of the shaft.
- Excessive wear, damage, peeling, and other non-standard conditions of the gears.

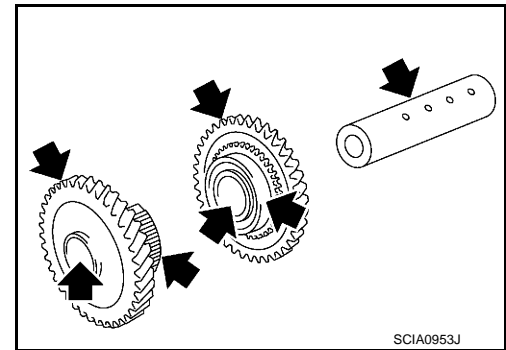

##### Synchronizer

Check items below. If necessary, replace them with new ones.

- Damage and unusual wear on contact surfaces of coupling sleeve, synchronizer hub of reverse idler gear (rear), and insert spring.
- Coupling sleeve and synchronizer hub of reverse idler gear (rear) must move smoothly.

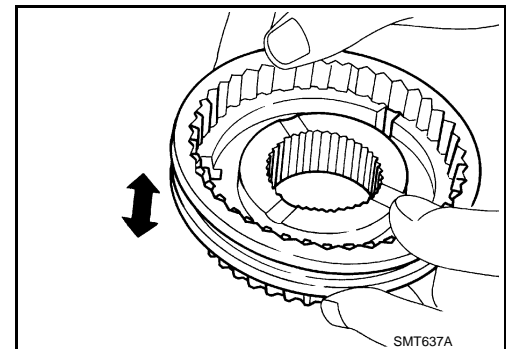

- If any crack, damage, or excessive wear is found on cam face of baulk ring or working face of insert, replace it.

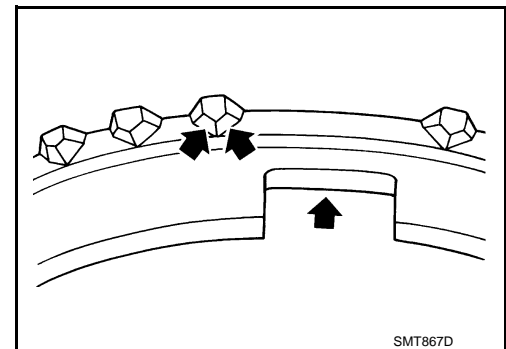

#### BAULK RING CLEARANCE

A  
B  
C  
TM  
E  
F  
G  
H  
I  
J  
K  
L  
M  
N  
O  
P

# REVERSE IDLER SHAFT AND GEARS

< UNIT DISASSEMBLY AND ASSEMBLY >

[6MT: RS6F52H]

- Push baulk ring on the cone and measure the clearance between baulk ring and cone. If the measurement is below limit, replace it with a new one.

## Clearance

**Standard value** : Refer to [TM-139, "Baulk Ring Clearance"](#).

**Limit value** : Refer to [TM-139, "Baulk Ring Clearance"](#).

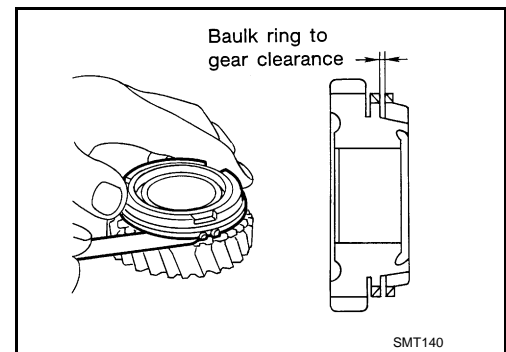

## Bearing

Check items below. If necessary, replace them with new ones.

- Damage and rough rotation of bearing.

## ASSEMBLY

Note the following, and assemble in the reverse order of disassembly.

### CAUTION:

- **Do not reuse retaining pin.**
- **Be careful with orientation of reverse insert spring.**

⇐ : Front

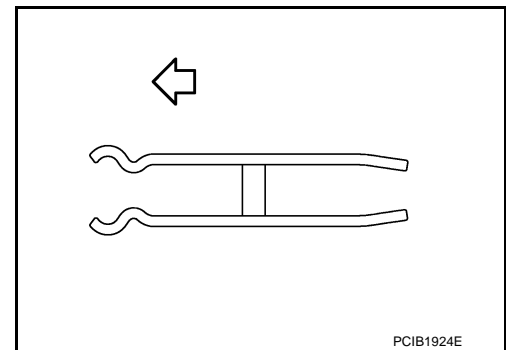

# FINAL DRIVE

< UNIT DISASSEMBLY AND ASSEMBLY >

[6MT: RS6F52H]

## FINAL DRIVE

### Exploded View

INFOID:000000010291445

FINAL DRIVE

FINAL DRIVE

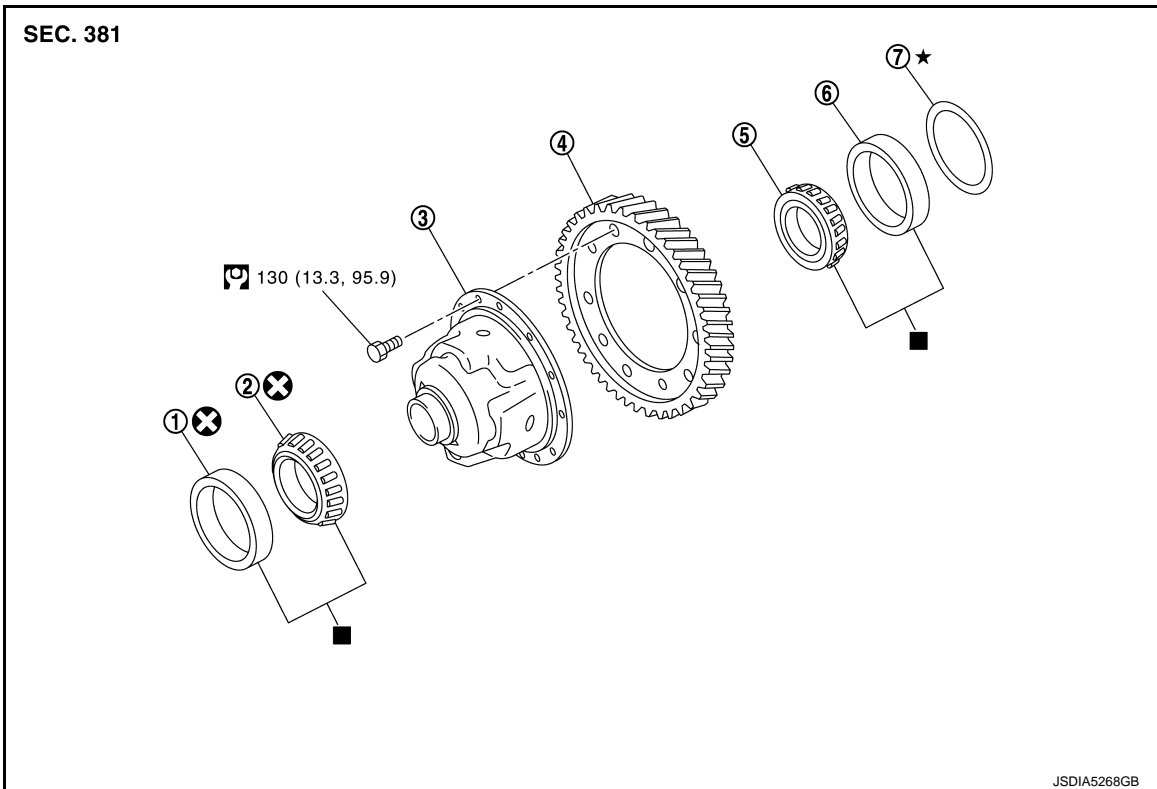

- |   |  |   |
|---|--|---|
| 1. Differential side bearing outer race (clutch housing side) | 2. Differential side bearing (clutch housing side) | 3. Differential case assembly                                 |
| 4. Final gear   | 5. Differential side bearing (transaxle case side) | 6. Differential side bearing outer race (transaxle case side) |
| 7. Differential side bearing adjusting shim                   |  |   |

■ : Replace the parts as a set.

🔧 : N·m (kg·m, ft·lb)

## Disassembly and Assembly

INFOID:000000010281904

### DISASSEMBLY

1. Remove final gear bolts and then separate the final gear from differential case.
2. Remove differential side bearing (clutch housing side) using Tool and pullers (B).

**Tool number**    **A: ST33061000 (J-8107-2)**

**CAUTION:**  
Hook a puller on the cage of differential side bearing.

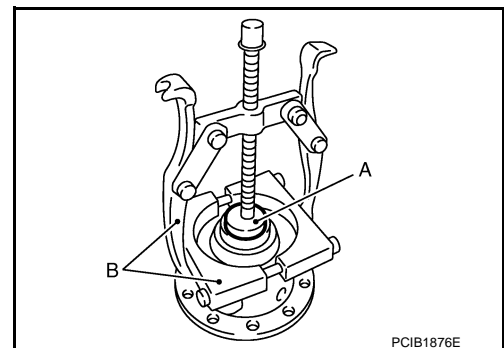

# FINAL DRIVE

< UNIT DISASSEMBLY AND ASSEMBLY >

[6MT: RS6F52H]

3. Remove differential side bearing (transaxle case side) using Tool and puller.

**Tool number**    **A: ST33061000 (J-8107-2)**

**CAUTION:**  
Hook a puller on the inner race of differential side bearing.

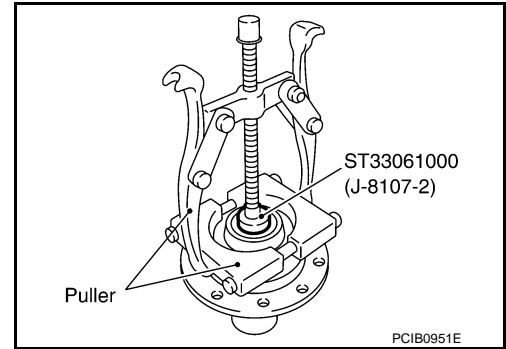

## INSPECTION AFTER DISASSEMBLY

### Bearing

- Check for bearings damage and rough rotation. If necessary, replace with a new one.

**CAUTION:**  
When replacing tapered roller bearing, replace outer and inner races as a set.

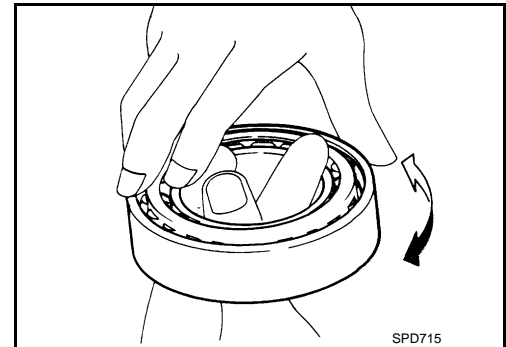

## ASSEMBLY

1. Press in differential side bearing (transaxle case side) to differential case using Tools.

**Tool number**    : KV38102510 ( — )  
                          : ST30720000 (J-25405)

**CAUTION:**  
Replace differential side bearing and differential side bearing outer race as a set.

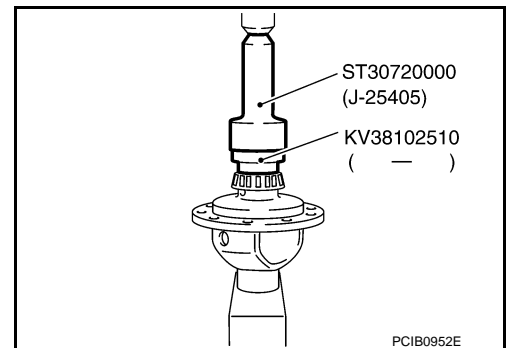

2. Press in differential side bearing (clutch housing side) to differential case using Tools.

**Tool number**    **A: ST30720000 (J-25405)**  
                          **B: KV38102510 ( — )**

**CAUTION:**  
• Do not reuse differential side bearing and differential side bearing outer race.  
• Replace differential side bearing and differential side bearing outer race as a set.

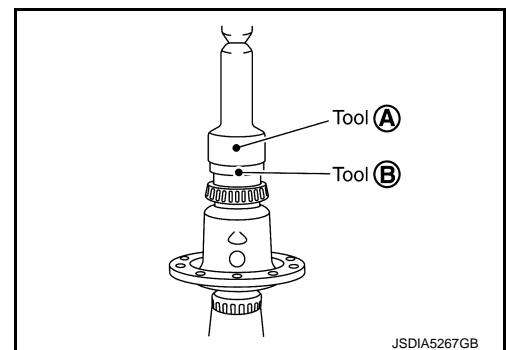

# FINAL DRIVE

## < UNIT DISASSEMBLY AND ASSEMBLY >

[6MT: RS6F52H]

3. Install final gear into differential case and tighten final gear bolts to the specified torque. Refer to [TM-131, "Exploded View"](#).

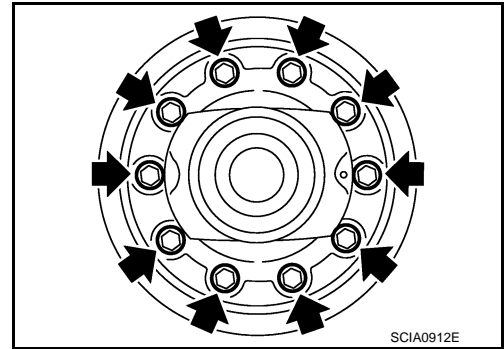

A  
B  
C

TM

E  
F  
G  
H  
I  
J  
K  
L  
M  
N  
O  
P

# SHIFT CONTROL

< UNIT DISASSEMBLY AND ASSEMBLY >

[6MT: RS6F52H]

## SHIFT CONTROL

Exploded View

INFOID:000000010335187

SHIFT CONTROL

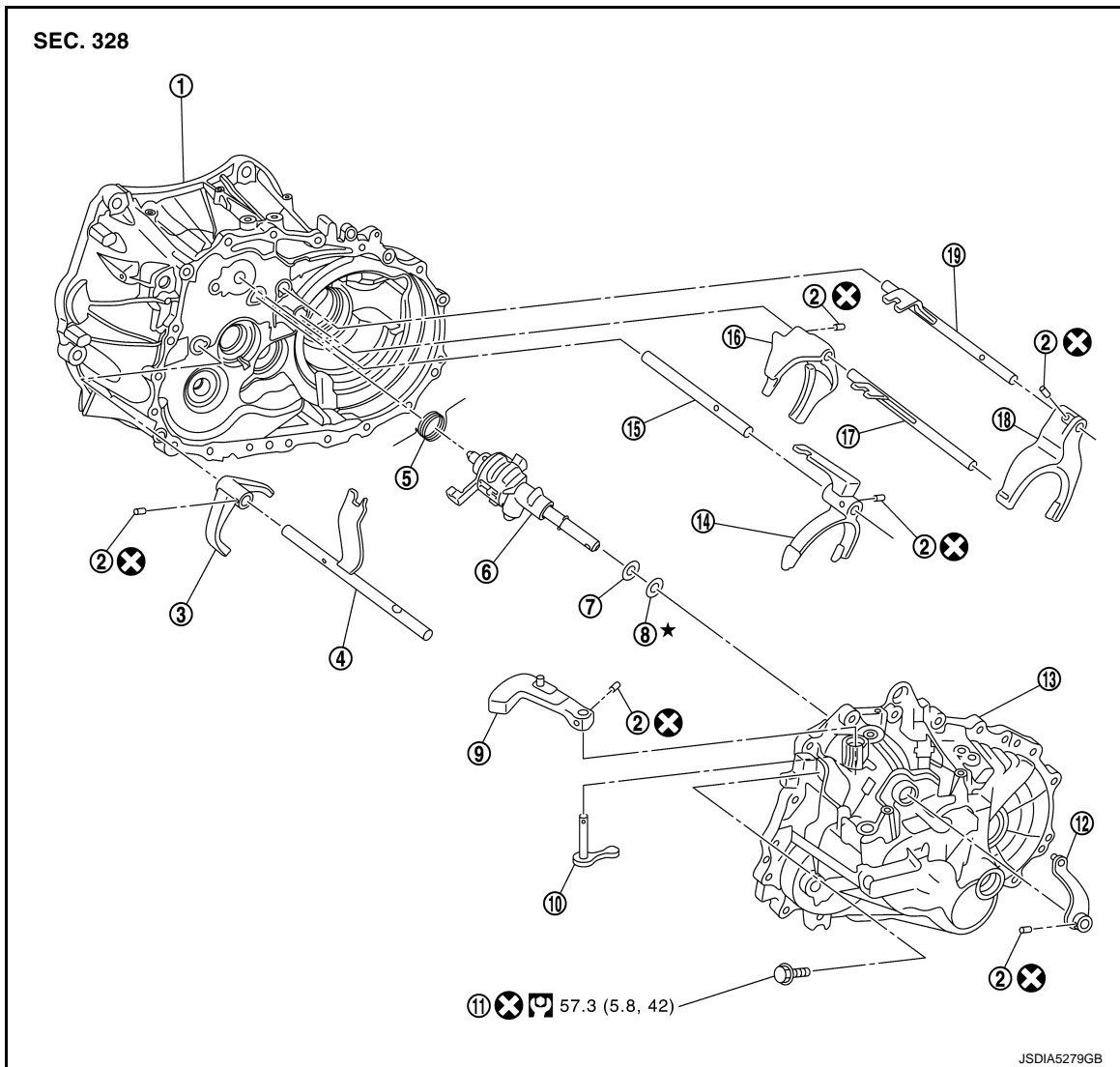

- |                        |                                |                          |
|------------------------|--------------------------------|--------------------------|
| 1. Clutch housing      | 2. Retaining pin               | 3. Reverse shift fork    |
| 4. Reverse fork rod    | 5. Return spring               | 6. Striking rod assembly |
| 7. Striking rod shim   | 8. Striking rod adjusting shim | 9. Shifter lever A       |
| 10. Shifter lever B    | 11. Guide bolt                 | 12. Selector lever       |
| 13. Transaxle case     | 14. 3rd-4th shift fork         | 15. 3rd-4th fork rod     |
| 16. 1st-2nd shift fork | 17. 1st-2nd fork rod           | 18. 5th-6th shift fork   |
| 19. 5th-6th fork rod   |                                |                          |

■ : Replace the parts as a set.

⊗ : Always replace after every disassembly.

## Disassembly and Assembly

INFOID:000000010281905

### DISASSEMBLY

# SHIFT CONTROL

## < UNIT DISASSEMBLY AND ASSEMBLY >

[6MT: RS6F52H]

1. Remove return spring to striking rod assembly.

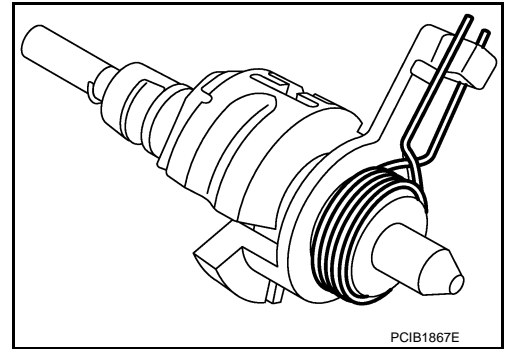

A  
B  
C

TM

## INSPECTION AFTER DISASSEMBLY

### Striking Rod Assembly and Return Spring

- Check contact surfaces and sliding area for wear, damage, bending, etc. If necessary, replace parts.

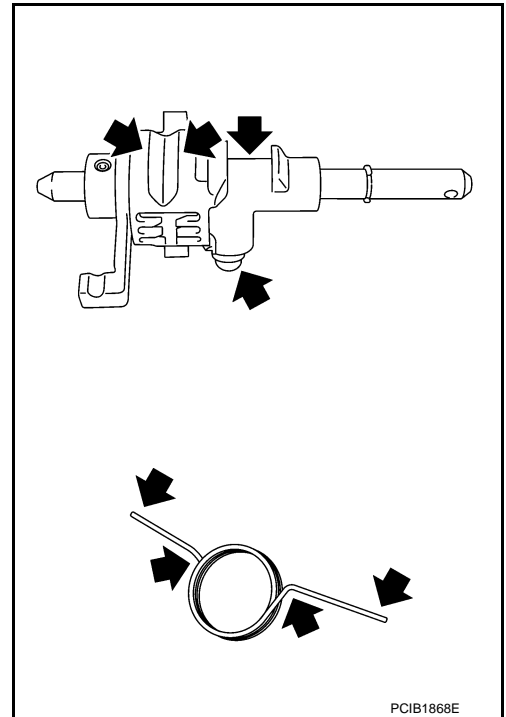

E  
F  
G  
H  
I  
J  
K

L

M

N

O

P

### Fork Rod and Shift Fork

# SHIFT CONTROL

[6MT: RS6F52H]

## < UNIT DISASSEMBLY AND ASSEMBLY >

- Check contact surfaces and sliding area for wear, damage, bending, etc. If necessary, replace parts.

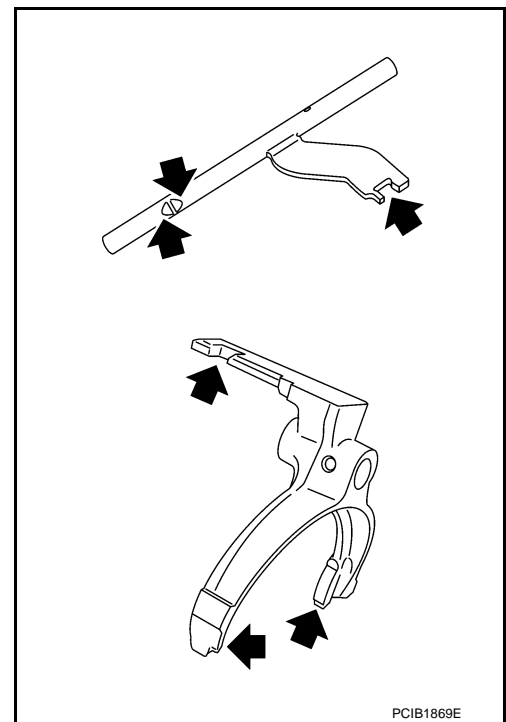

- Check if the width of shift fork hook (sliding area with coupling sleeve) is within allowable specification below.

Item	One-side wear specification	Sliding width of new part
1st-2nd	0.2 mm (0.008 in)	7.80 - 7.93 mm (0.3071 - 0.3122 in)
3rd-4th	0.2 mm (0.008 in)	7.80 - 7.93 mm (0.3071 - 0.3122 in)
5th-6th	0.2 mm (0.008 in)	6.10 - 6.23 mm (0.2402 - 0.2453 in)
Reverse	0.2 mm (0.008 in)	12.80 - 12.93 mm (0.5039 - 0.5091 in)

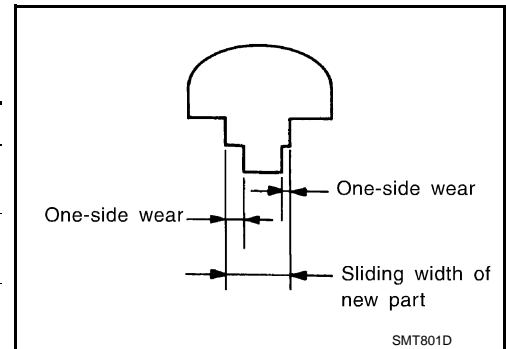

## ASSEMBLY

1. Temporarily install return spring to striking rod assembly.

**CAUTION:**

**Be careful with the orientation of return spring.**

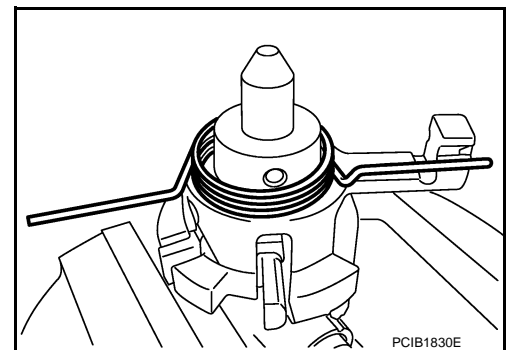



# SHIFT CONTROL

< UNIT DISASSEMBLY AND ASSEMBLY >

[6MT: RS6F52H]

2. Attach one end of the return spring to striking interlock of striking rod assembly while holding return spring.

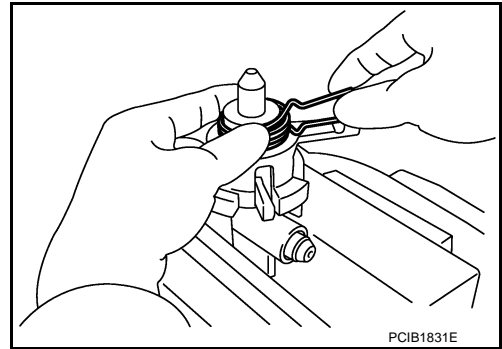

**CAUTION:**

- When installing, check that return spring is securely seated in the groove of striking interlock of striking rod assembly.

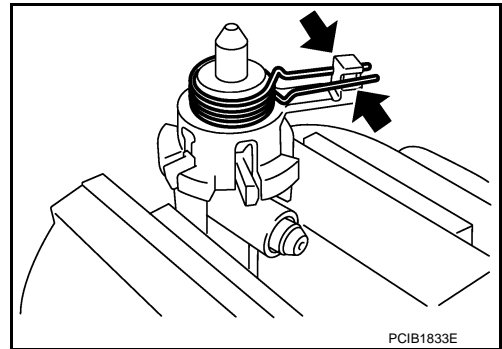

A

B

C

TM

E

F

G

H

I

J

K

L

M

N

O

P

# SERVICE DATA AND SPECIFICATIONS (SDS)

< SERVICE DATA AND SPECIFICATIONS (SDS)

[6MT: RS6F52H]

## SERVICE DATA AND SPECIFICATIONS (SDS)

### SERVICE DATA AND SPECIFICATIONS (SDS)

#### General Specification

INFOID:0000000010281906

#### TRANSAXLE

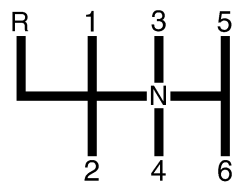
Engine type		MR16DDT	
Transaxle model		RS6F52H	
Model code number		3YW0D	
Number of speed		6	
Synchromesh type		Warner	
Shift pattern		 <p style="text-align: center;">PCIB1769E</p>	
Gear ratio	1st	3.727	
	2nd	2.043	
	3rd	1.392	
	4th	1.055	
	5th	0.865	
	6th	0.732	
	Reverse	3.641	
Number of teeth	Input gear	1st	11
		2nd	23
		3rd	28
		4th	36
		5th	52
		6th	56
		Reverse	11
	Main gear	1st	41
		2nd	47
		3rd	39
		4th	38
		5th	45
		6th	41
		Reverse	38
Reverse idler gear	Front	37	
	Rear	39	
Oil level	mm (in)	38.5 - 45.5 (1.516 - 1.791)	
Oil capacity (Reference)	ℓ (US pt, Imp pt)	1.9 (4, 3-3/8)	
Remarks	Reverse synchronizer	Installed	
	Double-cone synchronizer	3rd	
	Triple-cone synchronizer	1st and 2nd	

# SERVICE DATA AND SPECIFICATIONS (SDS)

< SERVICE DATA AND SPECIFICATIONS (SDS)

[6MT: RS6F52H]

## FINAL GEAR

Engine type	MR16DDT	
Transaxle model	RS6F52H	
Model code number	3YW0D	
Final gear ratio	4.428	
Number of teeth	Final gear/Pinion	62/14
	Side gear/Pinion mate gear	—

## Gear End Play

INFOID:0000000010281907

Unit: mm (in)

Gear	Standard value
1st main gear	0.20 - 0.30 (0.0079 - 0.0118)
2nd main gear	0.06 - 0.16 (0.0024 - 0.0063)
3rd input gear	0.18 - 0.31 (0.0071 - 0.0122)
4th input gear	0.20 - 0.30 (0.0079 - 0.0118)
5th input gear	0.06 - 0.16 (0.0024 - 0.0063)
6th input gear	0.06 - 0.16 (0.0024 - 0.0063)

## Baulk Ring Clearance

INFOID:0000000010281908

Unit: mm (in)

Measurement point		Standard value	Limit value
3rd (Double-cone synchronizer)	Clearance between synchronizer cone and inner baulk ring end face (A)	0.6 - 0.8 (0.024 - 0.031)	0.2 (0.008)
	Clearance between outer baulk ring pawl and synchronizer cone (B)	0.6 - 1.1 (0.024 - 0.043)	0.2 (0.008)
1st and 2nd (Triple-cone synchronizer)	Clearance between synchronizer cone and clutch gear end face (A)	0.6 - 1.2 (0.024 - 0.047)	0.3 (0.012)
	Clearance between outer baulk ring pawl and synchronizer cone (B)	0.6 - 1.1 (0.024 - 0.043)	0.2 (0.008)
	Clearance between inner baulk ring and clutch gear end face (C)	0.7 - 1.1 (0.028 - 0.043)	0.3 (0.012)
4th		0.9 - 1.45 (0.035 - 0.057)	0.7 (0.028)
5th		0.95 - 1.4 (0.037 - 0.055)	0.7 (0.028)
6th		0.95 - 1.4 (0.037 - 0.055)	0.7 (0.028)
Reverse		0.95 - 1.4 (0.037 - 0.055)	0.7 (0.028)

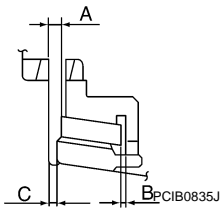
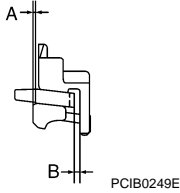

## Available Snap Rings

INFOID:0000000010281909

## 6TH INPUT GEAR BUSHING

# SERVICE DATA AND SPECIFICATIONS (SDS)

< SERVICE DATA AND SPECIFICATIONS (SDS)

[6MT: RS6F52H]

End play standard value		0 - 0.1 mm (0 - 0.004 in)	
Thickness mm (in)	Part number*	Thickness mm (in)	Part number*
1.76 (0.0693)	32204 8H511	2.01 (0.0791)	32204 8H516
1.81 (0.0713)	32204 8H512	2.06 (0.0811)	32204 8H517
1.86 (0.0732)	32204 8H513	2.11 (0.0831)	32204 8H518
1.91 (0.0752)	32204 8H514	2.16 (0.0850)	32204 8H519
1.96 (0.0772)	32204 8H515	2.21 (0.0870)	32204 8H520

\*: Always check with the Parts Department for the latest parts information.

## Available C-Rings

INFOID:0000000010281910

## MAINSHAFT C-RING

End play standard value		0 - 0.06 mm (0 - 0.0024 in)	
Thickness mm (in)	Part number*	Thickness mm (in)	Part number*
2.535 (0.0998)	32348 8H800	2.835 (0.1116)	32348 8H810
2.565 (0.1010)	32348 8H801	2.865 (0.1128)	32348 8H811
2.595 (0.1022)	32348 8H802	2.895 (0.1140)	32348 8H812
2.625 (0.1033)	32348 8H803	2.925 (0.1152)	32348 8H813
2.655 (0.1045)	32348 8H804	2.955 (0.1163)	32348 8H814
2.685 (0.1057)	32348 8H805	2.985 (0.1175)	32348 8H815
2.715 (0.1069)	32348 8H806	3.015 (0.1187)	32348 8H816
2.745 (0.1081)	32348 8H807	3.045 (0.1199)	32348 8H817
2.775 (0.1093)	32348 8H808	3.075 (0.1211)	32348 8H818
2.805 (0.1104)	32348 8H809		

\*: Always check with the Parts Department for the latest parts information.

## Available Thrust Washer

INFOID:0000000010281911

## INPUT SHAFT THRUST WASHER

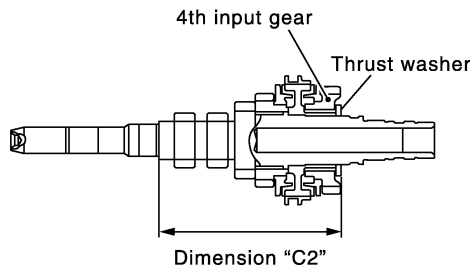

SCIA1008E

Standard value for dimension "C2"		154.7 - 154.8 mm (6.091 - 6.094 in)	
Thickness mm (in)	Part number*	Thickness mm (in)	Part number*
3.84 (0.1512)	32347 8H500	4.02 (0.1583)	32347 8H503
3.90 (0.1535)	32347 8H501	4.08 (0.1606)	32347 8H504
3.96 (0.1559)	32347 8H502	4.14 (0.1630)	32347 8H505

\*: Always check with the Parts Department for the latest parts information.

## DIFFERENTIAL SIDE GEAR THRUST WASHER

Allowable Clearance between side gear and differential case with thrust washer	0.1 - 0.2 mm (0.004 - 0.008 in)

# SERVICE DATA AND SPECIFICATIONS (SDS)

< SERVICE DATA AND SPECIFICATIONS (SDS)

[6MT: RS6F52H]

Thickness mm (in)	Part number*
0.75 (0.0295)	38424 81X00
0.80 (0.0315)	38424 81X01
0.85 (0.0335)	38424 81X02
0.90 (0.0354)	38424 81X03
0.95 (0.0374)	38424 81X04

\*: Always check with the Parts Department for the latest parts information.

## Available Adjusting Shims

INFOID:0000000010281912

### 4TH MAIN GEAR ADJUSTING SHIM

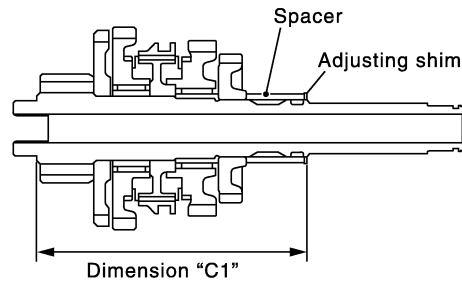

SCIA1009E

Standard value for dimension "C1"		173.85 - 173.95 mm (6.844 - 6.848 in)	
Thickness mm (in)	Part number*	Thickness mm (in)	Part number*
0.52 (0.0205)	32238 8H500	0.84 (0.0331)	32238 8H504
0.60 (0.0236)	32238 8H501	0.92 (0.0362)	32238 8H505
0.68 (0.0268)	32238 8H502	1.00 (0.0394)	32238 8H506
0.76 (0.0299)	32238 8H503	1.08 (0.0425)	32238 8H507

\*: Always check with the Parts Department for the latest parts information.

### INPUT SHAFT REAR BEARING ADJUSTING SHIM

End play standard value			0 - 0.06 mm (0 - 0.0024 in)		
Thickness mm (in)	Part number*	Thickness mm (in)	Part number*	Thickness mm (in)	Part number*
0.40 (0.0157)	32225 8H500	0.88 (0.0346)	32225 8H512	1.36 (0.0535)	32225 8H524
0.44 (0.0173)	32225 8H501	0.92 (0.0362)	32225 8H513	1.40 (0.0551)	32225 8H560
0.48 (0.0189)	32225 8H502	0.96 (0.0378)	32225 8H514	1.44 (0.0567)	32225 8H561
0.52 (0.0205)	32225 8H503	1.00 (0.0394)	32225 8H515	1.48 (0.0583)	32225 8H562
0.56 (0.0220)	32225 8H504	1.04 (0.0409)	32225 8H516	1.52 (0.0598)	32225 8H563
0.60 (0.0236)	32225 8H505	1.08 (0.0425)	32225 8H517	1.56 (0.0614)	32225 8H564
0.64 (0.0252)	32225 8H506	1.12 (0.0441)	32225 8H518	1.60 (0.0630)	32225 8H565
0.68 (0.0268)	32225 8H507	1.16 (0.0457)	32225 8H519	1.64 (0.0646)	32225 8H566
0.72 (0.0283)	32225 8H508	1.20 (0.0472)	32225 8H520		
0.76 (0.0299)	32225 8H509	1.24 (0.0488)	32225 8H521		
0.80 (0.0315)	32225 8H510	1.28 (0.0504)	32225 8H522		
0.84 (0.0331)	32225 8H511	1.32 (0.0520)	32225 8H523		

\*: Always check with the Parts Department for the latest parts information.

### MAINSHAFT REAR BEARING ADJUSTING SHIM

# SERVICE DATA AND SPECIFICATIONS (SDS)

< SERVICE DATA AND SPECIFICATIONS (SDS)

[6MT: RS6F52H]

End play standard value		0 - 0.06 mm (0 - 0.0024 in)	
Thickness mm (in)	Part number*	Thickness mm (in)	Part number*
0.44 (0.0173)	32238 8H510	0.80 (0.0315)	32238 8H519
0.48 (0.0189)	32238 8H511	0.84 (0.0331)	32238 8H520
0.52 (0.0205)	32238 8H512	0.88 (0.0346)	32238 8H521
0.56 (0.0220)	32238 8H513	0.92 (0.0362)	32238 8H522
0.60 (0.0236)	32238 8H514	0.96 (0.0378)	32238 8H523
0.64 (0.0252)	32238 8H515	1.00 (0.0394)	32238 8H524
0.68 (0.0268)	32238 8H516	1.04 (0.0409)	32238 8H560
0.72 (0.0283)	32238 8H517	1.08 (0.0425)	32238 8H561
0.76 (0.0299)	32238 8H518		

\*: Always check with the Parts Department for the latest parts information.

## REVERSE IDLER GEAR ADJUSTING SHIM

End play standard value		0.04 - 0.10 mm (0.0016 - 0.0039 in)	
Thickness mm (in)	Part number*	Thickness mm (in)	Part number*
1.76 (0.0693)	32237 8H800	2.24 (0.0882)	32237 8H812
1.80 (0.0709)	32237 8H801	2.28 (0.0898)	32237 8H813
1.84 (0.0724)	32237 8H802	2.32 (0.0913)	32237 8H814
1.88 (0.0740)	32237 8H803	2.36 (0.0929)	32237 8H815
1.92 (0.0756)	32237 8H804	2.40 (0.0945)	32237 8H816
1.96 (0.0772)	32237 8H805	2.44 (0.0961)	32237 8H817
2.00 (0.0787)	32237 8H806	2.48 (0.0976)	32237 8H818
2.04 (0.0803)	32237 8H807	2.52 (0.0992)	32237 8H819
2.08 (0.0819)	32237 8H808	2.56 (0.1008)	32237 8H820
2.12 (0.0835)	32237 8H809	2.60 (0.1024)	32237 8H821
2.16 (0.0850)	32237 8H810	2.64 (0.1039)	32237 8H822
2.20 (0.0866)	32237 8H811		

\*: Always check with the Parts Department for the latest parts information.

## 6TH MAIN GEAR ADJUSTING SHIM

End play standard value		0 - 0.1 mm (0 - 0.004 in)	
Thickness mm (in)	Part number*	Thickness mm (in)	Part number*
0.88 (0.0346)	32237 8H560	1.20 (0.0472)	32237 8H564
0.96 (0.0378)	32237 8H561	1.28 (0.0504)	32237 8H565
1.04 (0.0409)	32237 8H562	1.36 (0.0535)	32237 8H566
1.12 (0.0441)	32237 8H563		

\*: Always check with the Parts Department for the latest parts information.

## STRIKING ROD ADJUSTING SHIM

End play standard value		0.05 - 0.152 mm (0.0020 - 0.0060 in)	
Thickness mm (in)	Part number*	Thickness mm (in)	Part number*
1.12 (0.0441)	33761 JA60A	1.52 (0.0598)	33761 JA65A
1.20 (0.0472)	33761 JA61A	1.60 (0.0630)	33761 JA66A
1.28 (0.0504)	33761 JA62A	1.68 (0.0661)	33761 JA67A
1.36 (0.0535)	33761 JA63A	1.76 (0.0693)	33761 JA68A
1.44 (0.0567)	33761 JA64A	1.84 (0.0724)	33761 JA69A

\*: Always check with the Parts Department for the latest parts information.

## Available Shims

INFOID:000000010281913

### — Differential Side Bearing Preload and Adjusting Shim

#### BEARING PRELOAD

Differential side bearing preload: L*	0.15 - 0.21 mm (0.0059 - 0.0083 in)
---------------------------------------	-------------------------------------

# SERVICE DATA AND SPECIFICATIONS (SDS)

< SERVICE DATA AND SPECIFICATIONS (SDS)

[6MT: RS6F52H]

\*: Install shims which are "deflection of differential case" + "L" in thickness.

## DIFFERENTIAL SIDE BEARING ADJUSTING SHIM(S)

Thickness mm (in)	Part number*	Thickness mm (in)	Part number*
0.48 (0.0189)	31438 80X00	0.72 (0.0283)	31438 80X06
0.52 (0.0205)	31438 80X01	0.76 (0.0299)	31438 80X07
0.56 (0.0220)	31438 80X02	0.80 (0.0315)	31438 80X08
0.60 (0.0236)	31438 80X03	0.84 (0.0331)	31438 80X09
0.64 (0.0252)	31438 80X04	0.88 (0.0346)	31438 80X10
0.68 (0.0268)	31438 80X05	0.92 (0.0362)	31438 80X11

\*: Always check with the Parts Department for the latest parts information.

A

B

C

TM

E

F

G

H

I

J

K

L

M

N

O

P

## PRECAUTION

### PRECAUTIONS

#### Precaution for Supplemental Restraint System (SRS) "AIR BAG" and "SEAT BELT PRE-TENSIONER"

INFOID:000000009752488

The Supplemental Restraint System such as "AIR BAG" and "SEAT BELT PRE-TENSIONER", used along with a front seat belt, helps to reduce the risk or severity of injury to the driver and front passenger for certain types of collision. This system includes seat belt switch inputs and dual stage front air bag modules. The SRS system uses the seat belt switches to determine the front air bag deployment, and may only deploy one front air bag, depending on the severity of a collision and whether the front occupants are belted or unbelted. Information necessary to service the system safely is included in the "SRS AIR BAG" and "SEAT BELT" of this Service Manual.

**WARNING:**

Always observe the following items for preventing accidental activation.

- To avoid rendering the SRS inoperative, which could increase the risk of personal injury or death in the event of a collision that would result in air bag inflation, all maintenance must be performed by an authorized NISSAN/INFINITI dealer.
- Improper maintenance, including incorrect removal and installation of the SRS, can lead to personal injury caused by unintentional activation of the system. For removal of Spiral Cable and Air Bag Module, see "SRS AIR BAG".
- Never use electrical test equipment on any circuit related to the SRS unless instructed to in this Service Manual. SRS wiring harnesses can be identified by yellow and/or orange harnesses or harness connectors.

#### PRECAUTIONS WHEN USING POWER TOOLS (AIR OR ELECTRIC) AND HAMMERS

**WARNING:**

Always observe the following items for preventing accidental activation.

- When working near the Air Bag Diagnosis Sensor Unit or other Air Bag System sensors with the ignition ON or engine running, never use air or electric power tools or strike near the sensor(s) with a hammer. Heavy vibration could activate the sensor(s) and deploy the air bag(s), possibly causing serious injury.
- When using air or electric power tools or hammers, always switch the ignition OFF, disconnect the battery, and wait at least 3 minutes before performing any service.

#### Precaution for Procedure without Cowl Top Cover

INFOID:000000009752489

When performing the procedure after removing cowl top cover, cover the lower end of windshield with urethane, etc to prevent damage to windshield.

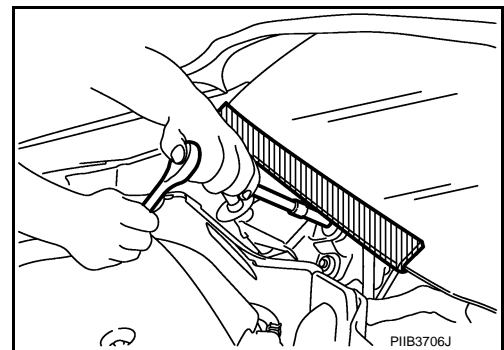



# PRECAUTIONS

< PRECAUTION >

[CVT: RE0F10B]

## Precautions for Removing of Battery Terminal

INFOID:000000010197929

- When removing the 12V battery terminal, turn OFF the ignition switch and wait at least 30 seconds.

**NOTE:**

ECU may be active for several tens of seconds after the ignition switch is turned OFF. If the battery terminal is removed before ECU stops, then a DTC detection error or ECU data corruption may occur.

- For vehicles with the 2-batteries, be sure to connect the main battery and the sub battery before turning ON the ignition switch.

**NOTE:**

If the ignition switch is turned ON with any one of the terminals of main battery and sub battery disconnected, then DTC may be detected.

- After installing the 12V battery, always check "Self Diagnosis Result" of all ECUs and erase DTC.

**NOTE:**

The removal of 12V battery may cause a DTC detection error.

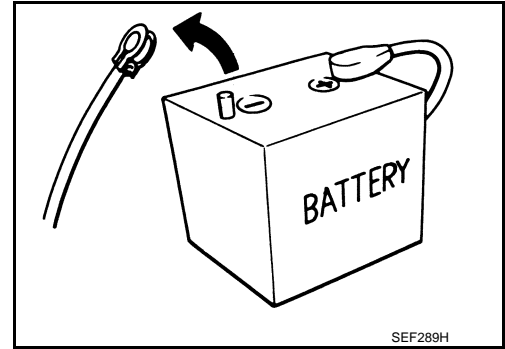

A  
B  
C  
TM

## Precaution for On Board Diagnosis (OBD) System of CVT and Engine

INFOID:000000009752490

The ECM has an on board diagnostic system. It will light up the malfunction indicator lamp (MIL) to warn the driver of a malfunction causing emission deterioration.

**CAUTION:**

- Be sure to turn the ignition switch OFF and disconnect the battery cable from the negative terminal before any repair or inspection work. The open/short circuit of related switches, sensors, solenoid valves, etc. will cause the MIL to light up.
- Be sure to connect and lock the connectors securely after work. A loose (unlocked) connector will cause the MIL to light up due to an open circuit. (Be sure the connector is free from water, grease, dirt, bent terminals, etc.)
- Be sure to route and secure the harnesses properly after work. Interference of the harness with a bracket, etc. may cause the MI to light up due to a short circuit.
- Be sure to connect rubber tubes properly after work. A misconnected or disconnected rubber tube may cause the MIL to light up due to a malfunction of the EVAP system or fuel injection system, etc.
- Be sure to erase the unnecessary malfunction information (repairs completed) from the TCM and ECM before returning the vehicle to the customer.

E  
F  
G  
H  
I  
J  
K

## Precaution for TCM and Transaxle Assembly or Control Valve Replacement

INFOID:000000009752491

**CAUTION:**

- To replace TCM, refer to [TM-213, "Description"](#).
- To replace transaxle assembly, refer to [TM-214, "Description"](#).
- To replace control valve, refer to [TM-214, "Description"](#).

L  
M

## Removal and Installation Procedure for CVT Unit Connector

INFOID:000000009752492

### REMOVAL

Rotate bayonet ring (1) counterclockwise, pull out CVT unit harness connector (2) upward and remove it.

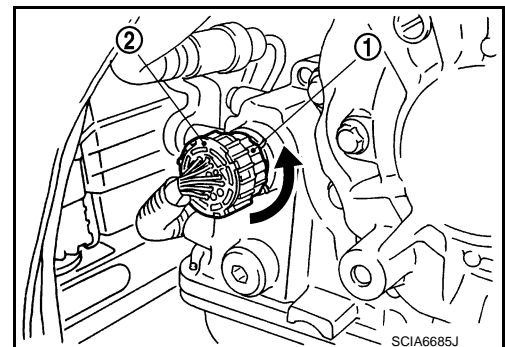

N  
O  
P

### INSTALLATION

# PRECAUTIONS

[CVT: RE0F10B]

## < PRECAUTION >

1. Align  $\Delta$  marking on CVT unit harness connector terminal body with  $\square$  marking on bayonet ring, insert CVT unit harness connector, and then rotate bayonet ring clockwise.

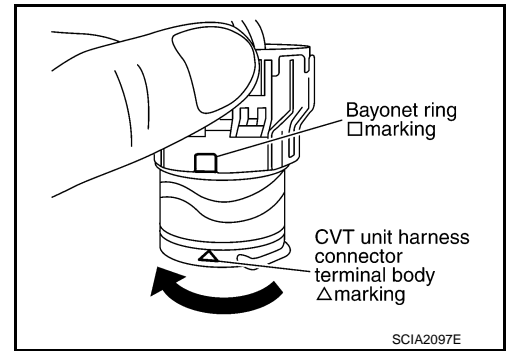

2. Rotate bayonet ring clockwise until  $\Delta$  marking on CVT unit harness connector terminal body is aligned with the slit on bayonet ring as shown in the figure (correctly fitting condition), install CVT unit harness connector to CVT unit harness connector terminal body.

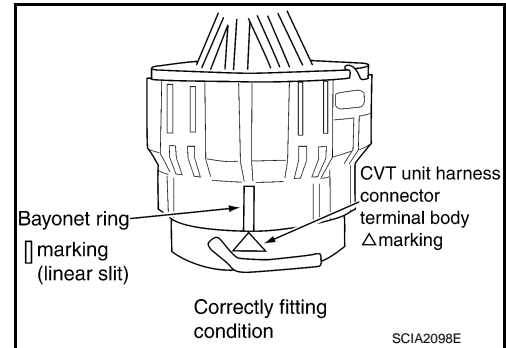

### CAUTION:

- Securely align  $\Delta$  marking on CVT unit harness connector terminal body with bayonet ring slit. Then, be careful not to make a half fit condition as shown in the figure.
- Never mistake the slit of bayonet ring for other dent portion.

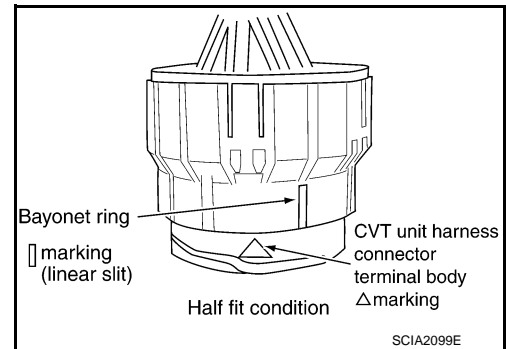

## General Precautions

INFOID:000000009752493

- Before connecting or disconnecting the TCM harness connector, turn ignition switch OFF and disconnect negative battery cable. Because battery voltage is applied to TCM even if ignition switch is turned OFF.

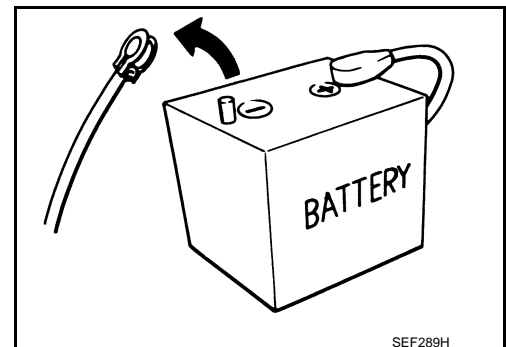

# PRECAUTIONS

< PRECAUTION >

[CVT: RE0F10B]

- When connecting or disconnecting pin connectors into or from TCM, take care not to damage pin terminals (bend or break).  
When connecting pin connectors make sure that there are not any bends or breaks on TCM pin terminal.

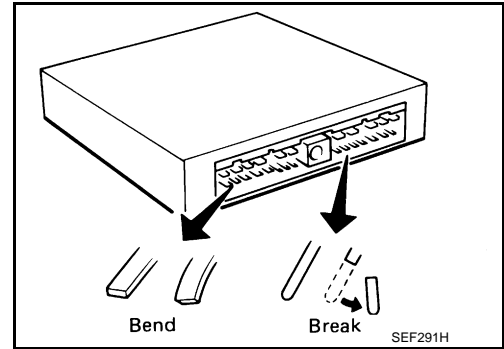

- Before replacing TCM, perform TCM input/output signal inspection and make sure whether TCM functions properly or not. Refer to [TM-190, "Reference Value"](#).

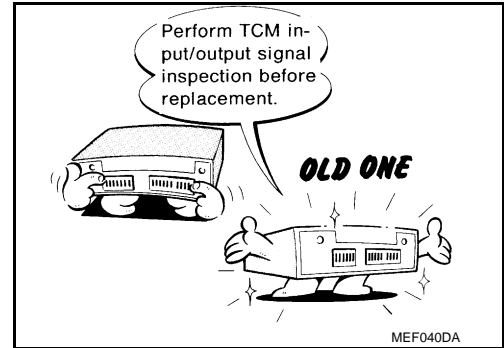

- After performing each TROUBLE DIAGNOSIS, perform "DTC Confirmation Procedure".  
If the repair is completed the DTC should not be displayed in the "DTC Confirmation Procedure".
- Always use the specified brand of CVT fluid. Refer to [MA-10, "Fluids and Lubricants"](#).
- Use lint-free paper, not cloth rags, during work.
- After replacing the CVT fluid, dispose of the waste oil using the methods prescribed by law, ordinance, etc.

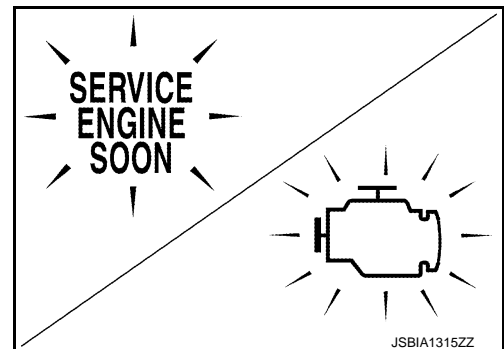

## Service Notice or Precaution

INFOID:000000009752494

### OBD-II SELF-DIAGNOSIS

- CVT self-diagnosis is performed by the TCM in combination with the ECM. The results can be read through the blinking pattern of the malfunction indicator lamp (MIL). Refer to the table on [TM-185, "CONSULT Function"](#) for the indicator used to display each self-diagnostic result.
- The self-diagnostic results indicated by the MI are automatically stored in both the ECM and TCM memories. **Always perform the procedure on [TM-183, "Diagnosis Description"](#) to complete the repair and avoid unnecessary blinking of the MIL.**

For details of OBD-II, refer to [EC-60, "Diagnosis Description"](#).

- Certain systems and components, especially those related to OBD-II, may use the new style slide-locking type harness connector. For description and how to disconnect, refer to [PG-5, "Harness Connector"](#).

A  
B  
C  
TM  
E  
F  
G  
H  
I  
J  
K  
L  
M  
N  
O  
P

# PREPARATION

< PREPARATION >

[CVT: RE0F10B]



## PREPARATION

### PREPARATION

#### Special Service Tool

INFOID:000000009752495

The actual shapes of Kent-Moore tools may differ from those of special service tools illustrated here.

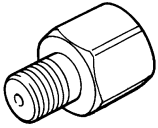
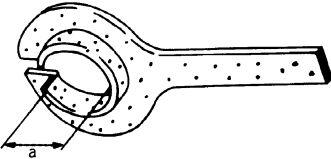
Tool number (Kent-Moore No.) Tool name		Description
— (OTC3492) Oil pressure gauge set	 <p style="text-align: right; font-size: small;">SCIA7531E</p>	Measuring line pressure
1. ST25054000 ( — ) Adapter 2. ST25055000 ( — ) Adapter	 <p style="text-align: right; font-size: small;">SCIA8372J</p>	Measuring line pressure
KV31103600 (J-45674) Joint pipe adapter (With ST25054000)	 <p style="text-align: right; font-size: small;">ZZA1227D</p>	Measuring line pressure
KV38107900 ( — ) Protector a: 32 mm (1.26 in) dia.	 <p style="text-align: right; font-size: small;">PDIA1183J</p>	Installing drive shaft

#### Commercial Service Tool

INFOID:000000009752496

# PREPARATION

< PREPARATION >

[CVT: RE0F10B]

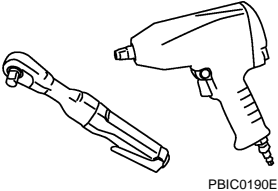
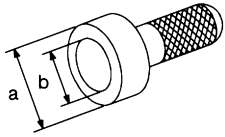
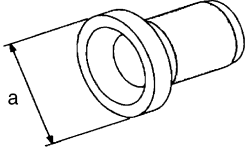
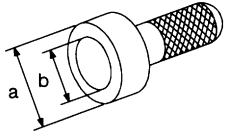
Tool number Tool name	Description	
Power tool	Loosening nuts and bolts	A
 <p style="text-align: center;">PBIC0190E</p>		B C
Drift a: 54 mm (2.13 in) dia. b: 50 mm (1.97 in) dia.	<ul style="list-style-type: none"> <li>• Installing differential side oil seal (transaxle case side)</li> <li>• Installing differential side oil seal (converter housing side) (2WD)</li> </ul>	TM
 <p style="text-align: center;">NT115</p>		E
Drift a: 60 mm (2.36 in) dia.	Installing differential side oil seal (converter housing side) (AWD)	F
 <p style="text-align: center;">SCIA5338E</p>		G H
Drift a: 65 mm (2.13 in) dia. b: 60 mm (1.97 in) dia.	Installing converter housing oil seal	I
 <p style="text-align: center;">NT115</p>		J K L M N O P

## SYSTEM DESCRIPTION

### COMPONENT PARTS CVT CONTROL SYSTEM

#### CVT CONTROL SYSTEM : Component Parts Location

INFOID:000000009752497

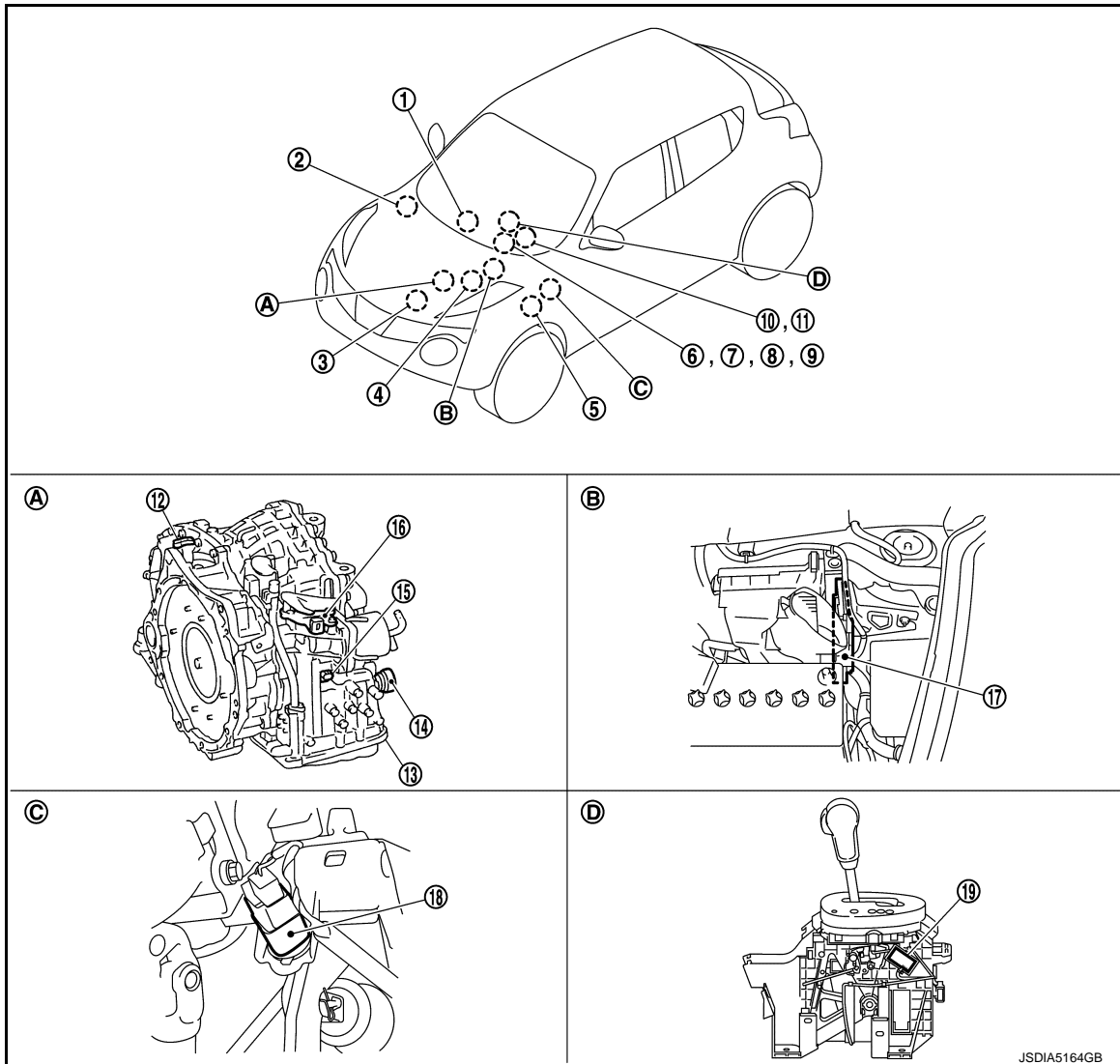

- |   |   |  |
|---|---|--|
| 1. Multi display unit (MDU)* <sup>1</sup><br>Refer to <a href="#">DMS-3, "Component Parts Location"</a> .   | 2. ABS actuator and electric unit (control unit)<br>Refer to <a href="#">BRC-9, "Component Parts Location"</a> .  | 3. ECM<br>Refer to <a href="#">EC-14, "ENGINE CONTROL SYSTEM : Component Parts Location"</a> . |
| 4. IPDM E/R<br>Refer to <a href="#">PCS-5, "Component Parts Location"</a> (With Intelligent Key system), <a href="#">PCS-37, "Component Parts Location"</a> (Without Intelligent Key system). | 5. BCM<br>Refer to <a href="#">BCS-6, "BODY CONTROL SYSTEM : Component Parts Location"</a> (With Intelligent Key system), <a href="#">BCS-93, "BODY CONTROL SYSTEM : Component Parts Location"</a> (Without Intelligent Key system) | 6. Combination meter   |
| 7. Manual mode indicator<br>(On the combination meter)  | 8. Shift position indicator<br>(On the combination meter)   | 9. CVT indicator<br>(On the combination meter)   |
| 10. Paddle shifter (shift-down switch)* <sup>3</sup>  | 11. Paddle shifter (shift-up switch)* <sup>3</sup>  | 12. Secondary speed sensor   |
| 13. Control valve* <sup>2</sup>   | 14. CVT unit connector  | 15. Primary speed sensor   |

JSDIA5164GB

# COMPONENT PARTS

[CVT: RE0F10B]

## < SYSTEM DESCRIPTION >

- |                                |                |                       |
|--------------------------------|----------------|-----------------------|
| 16. Transmission range switch  | 17. TCM        | 18. Stop lamp switch  |
| 19. Manual mode switch         |                |                       |
| A. Transaxle assembly          | B. Engine room | C. Brake pedal, upper |
| D. CVT shift selector assembly |                |                       |

\*1: With Integrated Control System

\*2: Control valve is installed in transaxle assembly.

\*3: NISMO RS models

### NOTE:

- The following components are included in control valve assembly (11).

- CVT fluid temperature sensor
- Secondary pressure sensor
- Line pressure solenoid valve
- Torque converter clutch solenoid valve
- Lock-up select solenoid valve
- Step motor
- ROM assembly

- The following components are included in manual mode switch (17).

- Mode select switch
- Select position switch

## CVT CONTROL SYSTEM : Component Description

INFOID:000000009752498

Name	Function
TCM	<a href="#">TM-152, "CVT CONTROL SYSTEM : TCM"</a>
Transmission range switch	<a href="#">TM-152, "CVT CONTROL SYSTEM : Transmission Range Switch"</a>
Primary speed sensor	<a href="#">TM-152, "CVT CONTROL SYSTEM : Primary Speed Sensor"</a>
Secondary speed sensor	<a href="#">TM-153, "CVT CONTROL SYSTEM : Secondary Speed Sensor"</a>
CVT fluid temperature sensor	<a href="#">TM-153, "CVT CONTROL SYSTEM : CVT Fluid Temperature Sensor"</a>
Secondary pressure sensor	<a href="#">TM-154, "CVT CONTROL SYSTEM : Secondary Pressure Sensor"</a>
Line pressure solenoid valve	<a href="#">TM-154, "CVT CONTROL SYSTEM : Line Pressure Solenoid Valve"</a>
Secondary pressure solenoid valve	<a href="#">TM-154, "CVT CONTROL SYSTEM : Secondary Pressure Solenoid Valve"</a>
Torque converter clutch solenoid valve	<a href="#">TM-155, "CVT CONTROL SYSTEM : Torque Converter Clutch Solenoid Valve"</a>
Lock-up select solenoid valve	<a href="#">TM-155, "CVT CONTROL SYSTEM : Lock-up Select Solenoid Valve"</a>
Step motor	<a href="#">TM-155, "CVT CONTROL SYSTEM : Step Motor"</a>
Manual mode switch	<a href="#">TM-155, "CVT CONTROL SYSTEM : Manual Mode Switch"</a>
Shift position indicator	<a href="#">TM-156, "CVT CONTROL SYSTEM : Shift Position Indicator"</a>
Manual mode indicator	<a href="#">TM-156, "CVT CONTROL SYSTEM : Manual Mode Indicator"</a>
Paddle shifter (shift-down switch) <sup>*2</sup>	<a href="#">TM-156, "CVT CONTROL SYSTEM : Paddle Shifter"</a>
Paddle shifter (shift-up switch) <sup>*2</sup>	<a href="#">TM-156, "CVT CONTROL SYSTEM : Paddle Shifter"</a>
Accelerator pedal position sensor	<a href="#">EC-20, "Accelerator Pedal Position Sensor"</a>
Stop lamp switch	<a href="#">BRC-13, "Stop Lamp Switch"</a>

# COMPONENT PARTS

< SYSTEM DESCRIPTION >

[CVT: RE0F10B]

Name	Function
ECM	<ul style="list-style-type: none"> <li>For purposes including improving the feeling when shifting speeds and preventing drops in engine speed, control signals are exchanged between the ECM and TCM, and real-time cooperative control is performed according to the vehicle driving conditions. (Engine and CVT integrated control)</li> <li>Engine and CVT integrated control signal</li> </ul> <p><b>NOTE:</b> General term for the communication (torque-down permission, torque-down request, etc.) exchanged between the ECM and TCM.</p> <ul style="list-style-type: none"> <li>The TCM receives the following signal via CAN communications from the ECM for judging the vehicle driving conditions. <ul style="list-style-type: none"> <li>Engine speed signal</li> <li>Accelerator pedal position signal</li> <li>Closed throttle position signal</li> </ul> </li> </ul>
BCM	<p>The TCM receives the following signal via CAN communications from the BCM for judging the vehicle driving conditions.</p> <ul style="list-style-type: none"> <li>Stop lamp switch signal</li> </ul>
ABS actuator and electric unit (control unit)	<p>The TCM receives the following signal via CAN communications from the ABS actuator and electric unit (control unit) for judging the vehicle driving conditions.</p> <ul style="list-style-type: none"> <li>Vehicle speed signal (ABS)</li> <li>ABS operation signal</li> </ul>
Combination meter	<p>The TCM receives the following signal via CAN communications from the combination meter for judging the driving request from the driver.</p> <ul style="list-style-type: none"> <li>Manual mode signal</li> <li>Non-manual mode signal</li> <li>Manual mode shift up signal</li> <li>Manual mode shift down signal</li> </ul>
IPDM E/R	<p>The TCM receives the following signal via CAN communications from the ABS actuator and electric unit (control unit) for judging the vehicle driving conditions.</p> <ul style="list-style-type: none"> <li>A/C compressor feedback signal</li> </ul>
MDU <sup>*1</sup>	<p>The TCM receives the following signals from MDU via CAN communication to switch driving mode of the Integrated Control System.</p> <ul style="list-style-type: none"> <li>NORMAL mode signal</li> <li>ECO mode signal</li> <li>SPORT mode signal</li> </ul>

\*1: With Integrated Control System

\*2: NISMO RS models

## CVT CONTROL SYSTEM : TCM

INFOID:000000009752499

- The vehicle driving status is judged based on the signals from the sensors, switches, and other control units, and the optimal transaxle control is performed.
- For TCM control items, refer to [TM-174. "CONTROL SYSTEM : System Description"](#).

## CVT CONTROL SYSTEM : Transmission Range Switch

INFOID:000000009752500

- The transmission range switch is installed to upper part of transaxle case.
- The transmission range switch detects the selector lever position.

## CVT CONTROL SYSTEM : Primary Speed Sensor

INFOID:000000009752501

- The primary speed sensor is installed to front part of transaxle assembly.
- The primary speed sensor detects primary pulley speed.



# COMPONENT PARTS

## < SYSTEM DESCRIPTION >

[CVT: RE0F10B]

- The primary speed sensor generates the ON-OFF pulse (short waveform) in proportion to the rotating body speed which is “The higher the rotating body speed is, the faster the change cycle is”. The TCM judges the rotating speed from the changing cycle of this pulse signal.

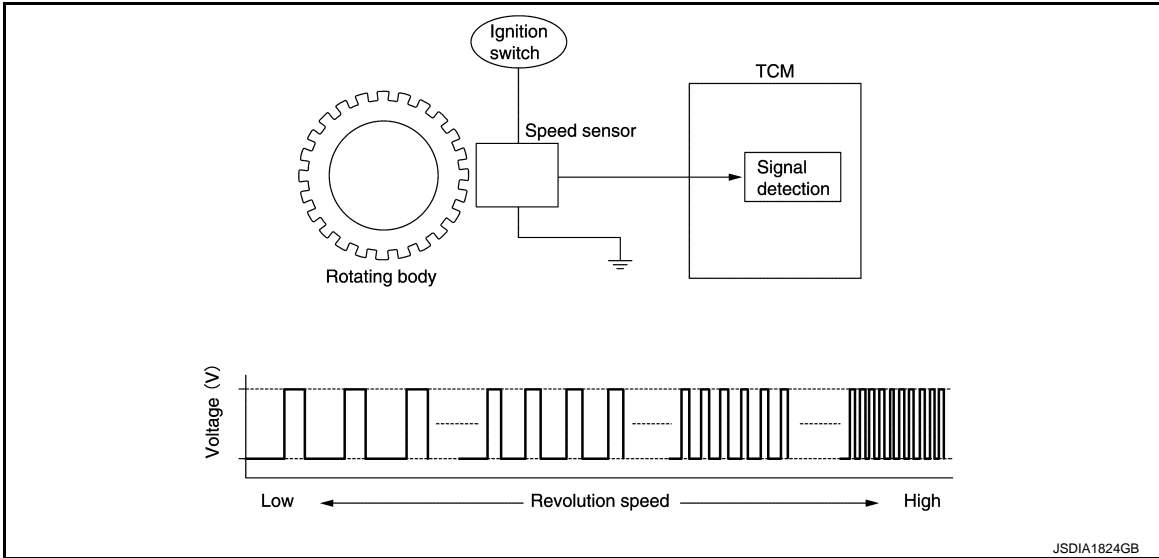

## CVT CONTROL SYSTEM : Secondary Speed Sensor

INFOID:000000009752502

- The secondary speed sensor is installed to upper part of converter housing.
- The secondary speed sensor detects secondary pulley speed.
- The secondary speed sensor generates the ON-OFF pulse (short waveform) in proportion to the rotating body speed which is “The higher the rotating body speed is, the faster the change cycle is”. The TCM judges the rotating speed from the changing cycle of this pulse signal.

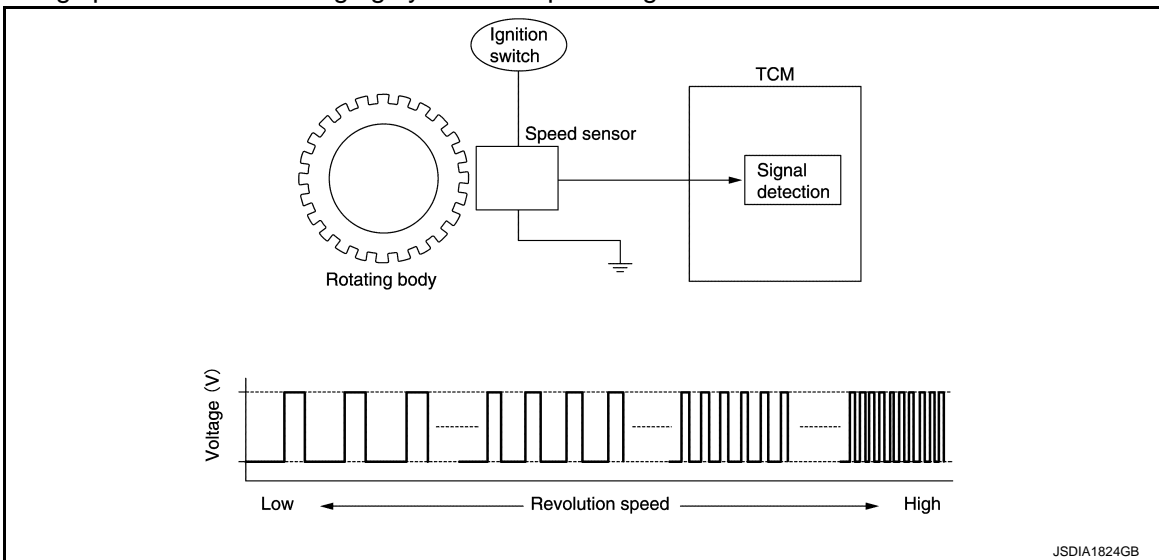

## CVT CONTROL SYSTEM : CVT Fluid Temperature Sensor

INFOID:000000009752503

- The CVT fluid temperature sensor is installed to control valve.
- The CVT fluid temperature sensor detects CVT fluid temperature in oil pan.

# COMPONENT PARTS

< SYSTEM DESCRIPTION >

[CVT: RE0F10B]

- The fluid temperature sensor uses a thermistor, and changes the signal voltage by converting changes in the CVT fluid temperature to a resistance value. TCM evaluates the CVT fluid temperature from the signal voltage value.

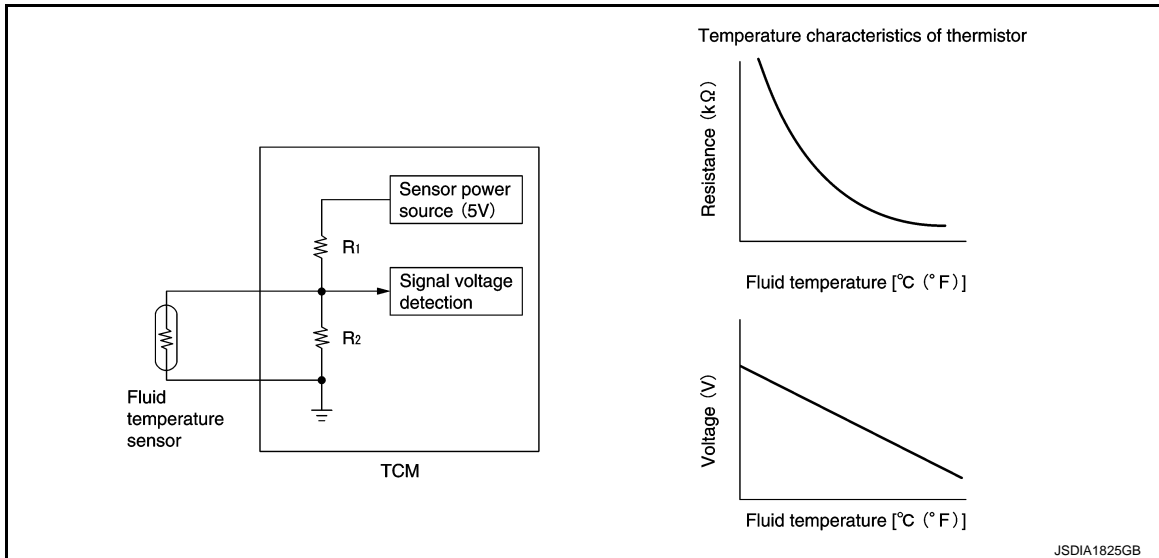

## CVT CONTROL SYSTEM : Secondary Pressure Sensor

INFOID:000000009752504

- The secondary pressure sensor is installed to control valve.
- The secondary pressure sensor detects the pressure applied to the secondary pulley.
- When pressure is applied to the ceramic device in the secondary pressure sensor, the ceramic device is deformed, resulting in voltage change. TCM evaluates the secondary pressure from its voltage change. Voltage is increased along with pressure increase.

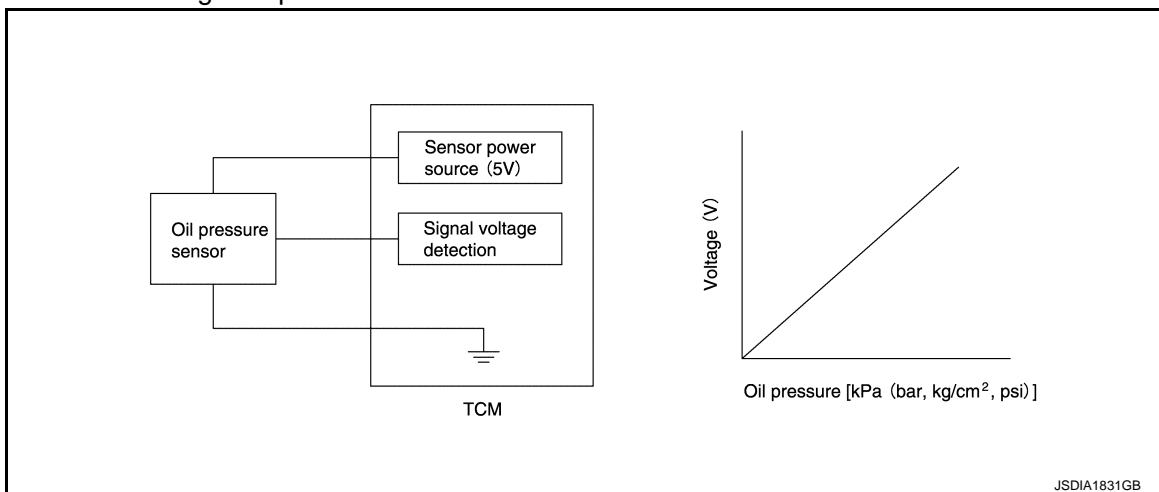

## CVT CONTROL SYSTEM : Line Pressure Solenoid Valve

INFOID:000000009752505

- The line pressure solenoid valve is installed to control valve.
- The line pressure solenoid valve controls the pressure regulator valve. For information about the pressure regulator valve, refer to [TM-167, "MECHANICAL SYSTEM : Component Description"](#).
- The line pressure solenoid valve uses the linear solenoid valve [N/H (normal high) type].

### NOTE:

- The principle of the linear solenoid valve utilizes the fact that the force pressing on the valve spool installed inside the coil increases nearly in proportion to the current. This allows it to produce a fluid pressure that is proportional to this pressing force.
- The N/H (normal high) produces hydraulic control when the coil is not energized.

## CVT CONTROL SYSTEM : Secondary Pressure Solenoid Valve

INFOID:000000009752506

- The secondary pressure solenoid valve is installed to control valve.

# COMPONENT PARTS

< SYSTEM DESCRIPTION >

[CVT: RE0F10B]

- The secondary pressure solenoid valve controls the secondary valve. For information about the secondary valve, refer to [TM-167, "MECHANICAL SYSTEM : Component Description"](#).
- The secondary pressure solenoid valve uses the linear solenoid valve [N/H (normal high) type].

A

B

C

TM

E

F

G

H

I

J

K

L

M

N

O

P

**NOTE:**

- The principle of the linear solenoid valve utilizes the fact that the force pressing on the valve spool installed inside the coil increases nearly in proportion to the current. This allows it to produce a fluid pressure that is proportional to this pressing force.
- The N/H (normal high) produces hydraulic control when the coil is not energized.

## CVT CONTROL SYSTEM : Torque Converter Clutch Solenoid Valve

INFOID:000000009752507

- The torque converter clutch solenoid valve is installed to control valve.
- The torque converter clutch solenoid valve controls the torque converter clutch control valve. For information about the torque converter clutch control valve, refer to [TM-167, "MECHANICAL SYSTEM : Component Description"](#).

**NOTE:**

- The torque converter clutch solenoid valve utilizes a linear solenoid valve [N/L (normal low) type].
- The principle of the linear solenoid valve utilizes the fact that the force pressing on the valve spool installed inside the coil increases nearly in proportion to the current. This allows it to produce a fluid pressure that is proportional to this pressing force.
- The N/L (normal low) type does not produce hydraulic control when the coil is not energized.

## CVT CONTROL SYSTEM : Lock-up Select Solenoid Valve

INFOID:000000009752508

- The lock-up select solenoid valve is installed to control valve.
- The lock-up select solenoid valve controls the select switch valve. For information about the select switch valve, refer to [TM-167, "MECHANICAL SYSTEM : Component Description"](#).
- The lock-up select solenoid valve utilizes an ON-OFF solenoid valve.

**NOTE:**

- The only operations of the valve spool installed inside the coil are pressing or not pressing the ball which seals the hydraulic supply section into the seat. This A/T uses N/L (normal low) type.
- When voltage is not applied to the coil, the force of the pilot pressure presses the ball against the seat, stopping the pilot pressure at that point.
- When voltage is applied to the coil, the valve is pulled in the direction of the coil, disengaging the hydraulic seal which the ball creates. This supplies pilot pressure to the operating locations.

## CVT CONTROL SYSTEM : Step Motor

INFOID:000000009752509

The step motor changes the step with turning 4 coils ON/OFF according to the signal from TCM. As a result, the flow of line pressure to primary pulley is changed and pulley ratio is controlled.

## CVT CONTROL SYSTEM : Manual Mode Switch

INFOID:000000009752510

- The manual mode switch [mode select switch and position select switch (shift-up/shift-down)] is installed in the CVT shift selector assembly.
- The mode select switch detects the position (the main shift gate side or manual shift gate side) of the selector lever and transmits a manual mode signal or a not manual mode signal to the combination meter. Then, the TCM receives a manual mode signal or non-manual mode signal from the combination meter.
- The position select switch (shift-up) detects that the selector lever is shifted to the shift-up side of the manual shift gate and transmits a manual mode shift up signal to the combination meter. Then, the TCM receives a manual mode shift up signal from the combination meter.
- The position select switch (shift-down) detects that the selector lever is shifted to the shift-down side of the manual shift gate and transmits a manual mode shift down signal to the combination meter. Then, the TCM receives a manual mode shift down signal from the combination meter.

## CVT CONTROL SYSTEM : CVT Indicator

INFOID:000000009752511

- CVT indicator is positioned on the combination meter.
- CVT indicator turns on for a certain period of time when the ignition switch turns ON, and then turns OFF.

# COMPONENT PARTS

< SYSTEM DESCRIPTION >

[CVT: RE0F10B]

Condition (status)	CVT indicator
Ignition switch OFF.	OFF
Ignition switch ON.	ON (Approx. 2sec.)

## CVT CONTROL SYSTEM : Shift Position Indicator

INFOID:000000009752512

TCM transmits shift position signal to combination meter via CAN communication. The actual shift position is displayed on combination meter according to the signal.

## CVT CONTROL SYSTEM : Manual Mode Indicator

INFOID:000000009752513

- Manual mode indicator (A) is positioned on the combination meter.
- The manual mode indicator illuminates when the selector lever is operated to the manual shift gate side. It also displays the gear position (M1↔M6) when the selector lever is operated to the + side or – side. (Operates only during driving.)
- The manual mode indicator turns off when the selector lever is operated to the main shift gate side.

Condition (status)	Manual mode indicator
Selector lever is operated to the manual shift gate side.	Display
Selector lever is operated to the + side or – side.	M1↔M6
Selector lever is operated to the main shift gate side.	Nothing displayed.

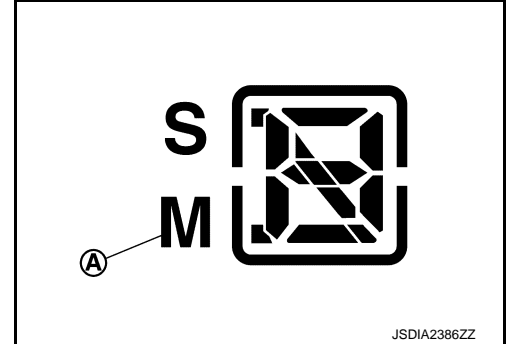

## CVT CONTROL SYSTEM : Paddle Shifter

INFOID:0000000010202410

- The paddle shifter is installed to the steering column.
- The paddle shifter transmits shift up and shift down signals to combination meter. Then TCM receives signals from the combination meter via CAN communication.

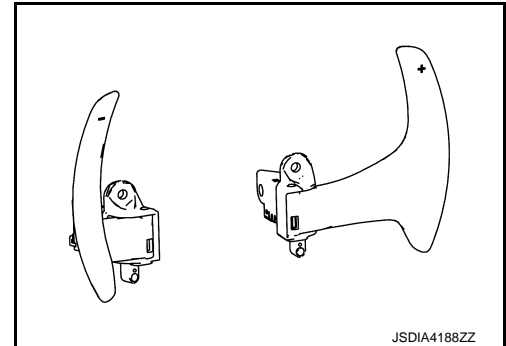

## SHIFT LOCK SYSTEM

# COMPONENT PARTS

< SYSTEM DESCRIPTION >

[CVT: RE0F10B]

## SHIFT LOCK SYSTEM : Component Parts Location

INFOID:000000009752514

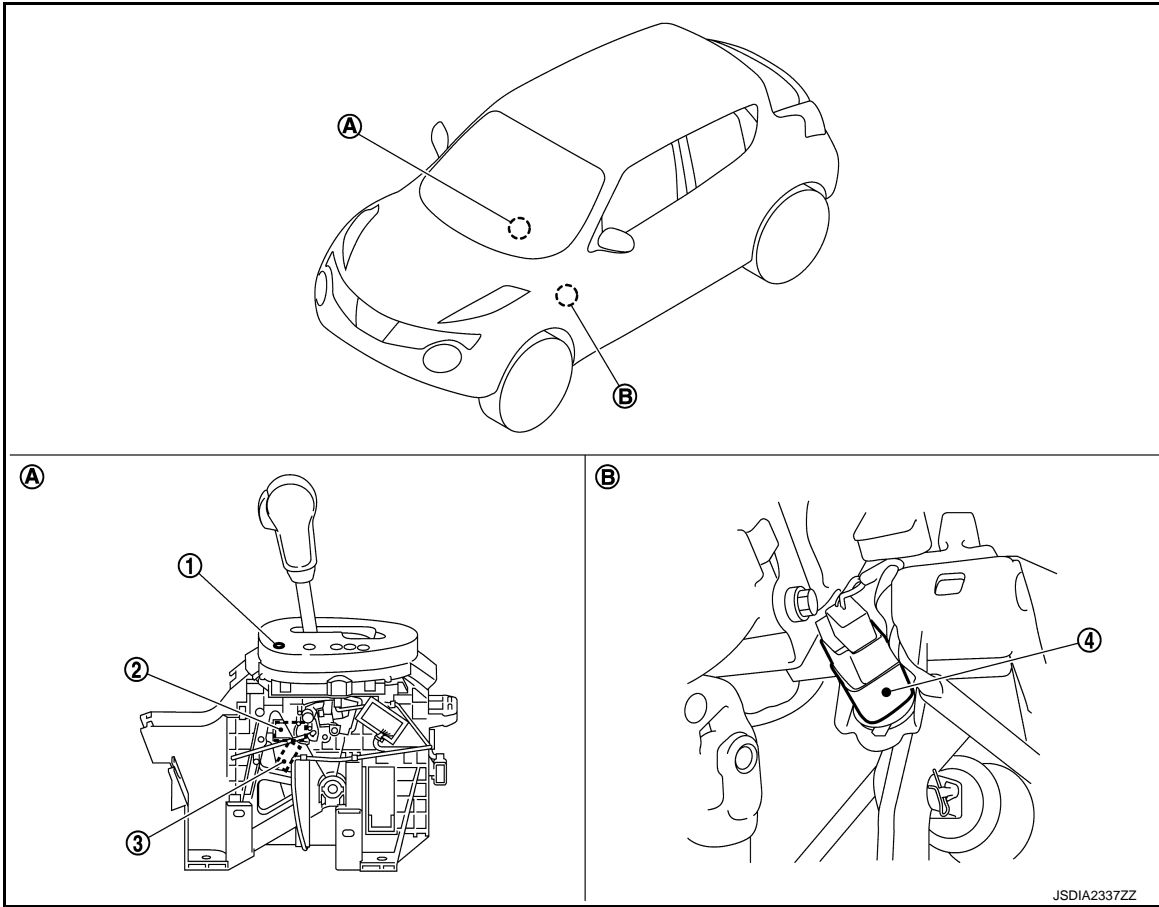

1. Shift lock release button cover\*      2. Shift lock solenoid      3. Park position switch  
 4. Stop lamp switch  
 A: CVT shift selector assembly      B: Brake pedal, upper

\*: Shift lock release button becomes operative by removing shift lock cover.

## SHIFT LOCK SYSTEM : Component Description

INFOID:000000009752515

Component	Function
Shift lock solenoid	It operates according to the signal from the stop lamp switch and moves the lock lever.
Lock lever	<ul style="list-style-type: none"> <li>Rotates according to shift lock solenoid activation and releases the shift lock.</li> <li>If shift lock solenoid does not activate, lock lever can be rotated when shift lock release button is pressed and shift lock is released.</li> </ul>
Detent rod	It links with the selector button and restricts the selector lever movement.
Park position switch	It detects that the selector lever is in "P" position.
Shift lock release button	Forcibly releases the shift lock when pressed.
Stop lamp switch	<ul style="list-style-type: none"> <li>The stop lamp switch turns ON when the brake pedal is depressed.</li> <li>When the stop lamp switch turns ON, the shift lock solenoid is energized.</li> </ul>

# STRUCTURE AND OPERATION

< SYSTEM DESCRIPTION >

[CVT: RE0F10B]

## STRUCTURE AND OPERATION TRANSAXLE

TRANSAXLE : Cross-Sectional View

INFOID:000000009752516

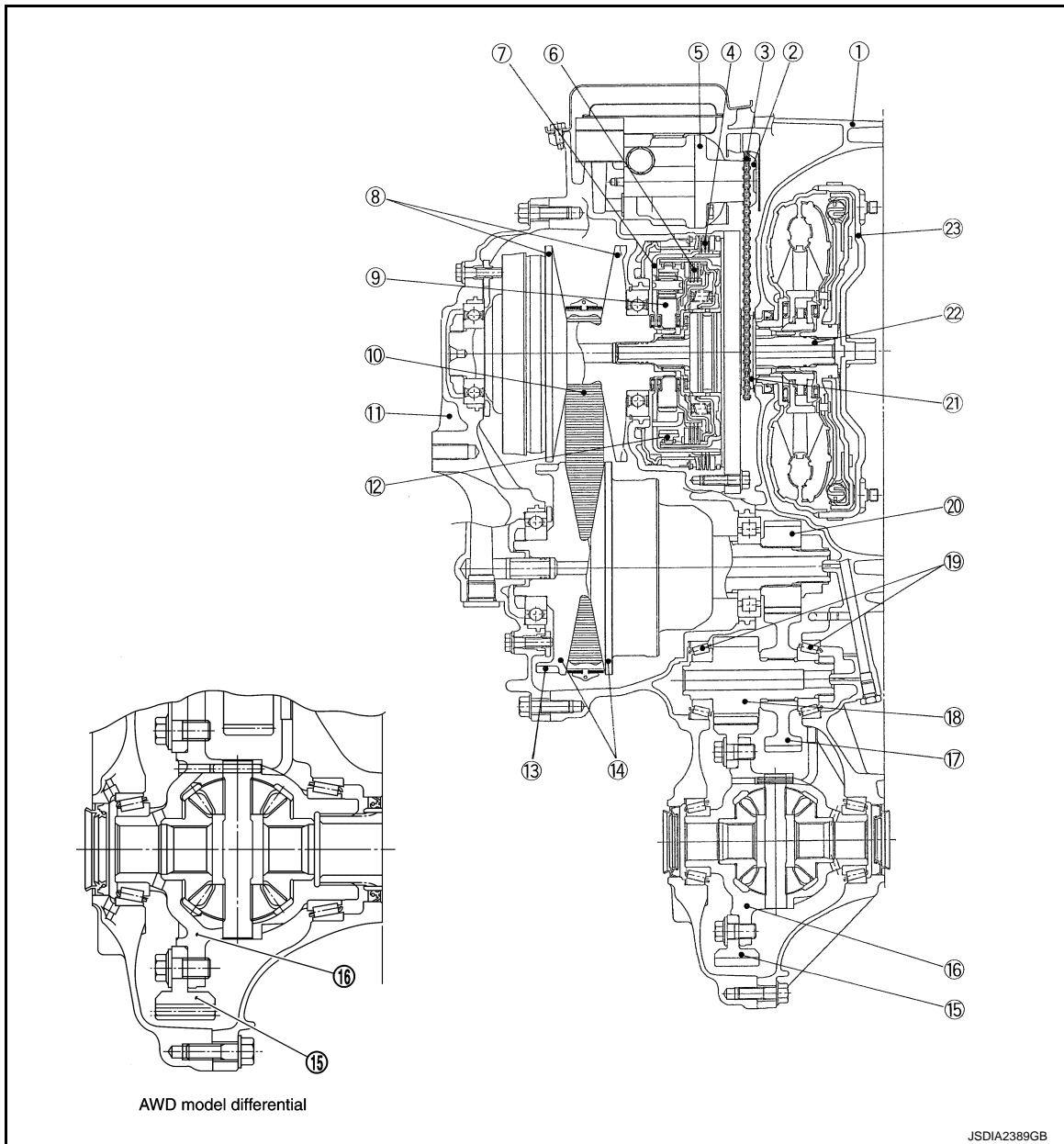

- |                          |                      |                    |
|--------------------------|----------------------|--------------------|
| 1. Converter housing     | 2. Driven sprocket   | 3. Chain           |
| 4. Reverse brake         | 5. Oil pump          | 6. Forward clutch  |
| 7. Planetary carrier     | 8. Primary pulley    | 9. Sun gear        |
| 10. Steel belt           | 11. Side cover       | 12. Internal gear  |
| 13. Parking gear         | 14. Secondary pulley | 15. Final gear     |
| 16. Differential case    | 17. Idler gear       | 18. Reduction gear |
| 19. Taper roller bearing | 20. Output gear      | 21. Drive sprocket |
| 22. Input shaft          | 23. Torque converter |                    |

## TRANSAXLE : Main Component Elements

INFOID:000000009752517

### TORQUE CONVERTER (WITH LOCK-UP FUNCTION)

In the same way as a conventional A/T, the torque converter is a system that increases the engine torque and transmits the torque to the transaxle. A symmetrical 3-element, 1-stage, 2-phase type is used here.

### OIL PUMP

Utilizes a vane-type oil pump that is driven by the engine through the oil pump drive chain in order to increase efficiency of pump discharge volume in low-speed zone and optimize pump discharge volume in high-speed zone. Discharged oil from oil pump is transmitted to control valve. It is used as the oil of primary and secondary pulley operation, the oil of clutch operation, and the lubricant for each part.

### FORWARD/REVERSE SELECTION UNIT

- A planetary gear type of forward/reverse selector mechanism is installed between the torque converter and primary pulley.
- The power from the torque converter is input via the input shaft, operating a wet multi-plate clutch by means of hydraulic pressure to switch between forward and reverse driving.

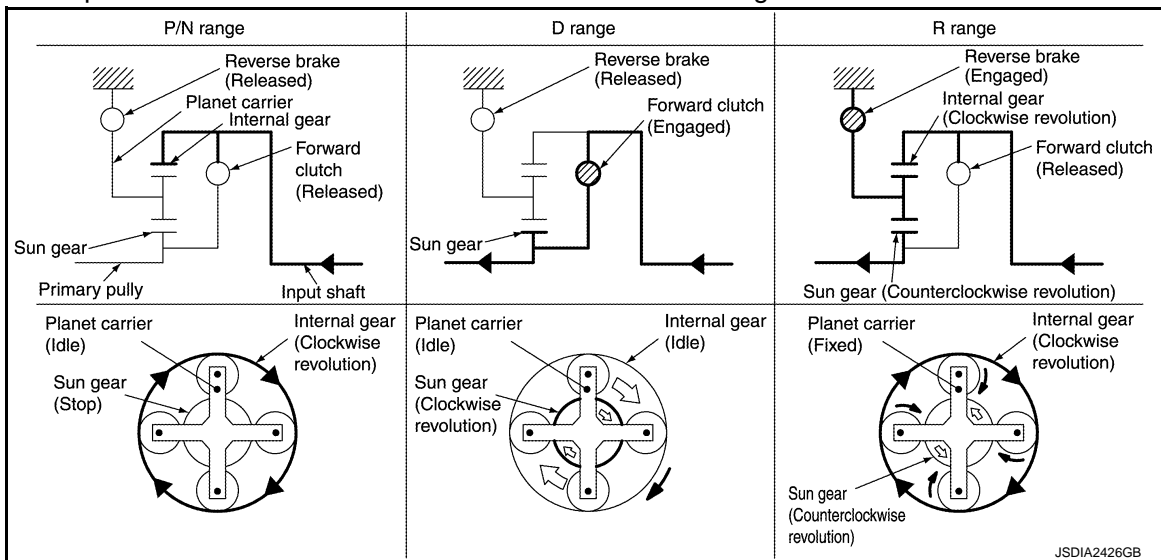

### FINAL DRIVE AND DIFFERENTIAL

The deceleration gears are composed of 2 stages: primary deceleration (output gear, idler gear pair) and secondary deceleration (reduction gear, final gear pair). All of these gears are helical gears.

The lubrication oil is the same as the fluid (Genuine CVT fluid) which lubricates the entire transaxle.

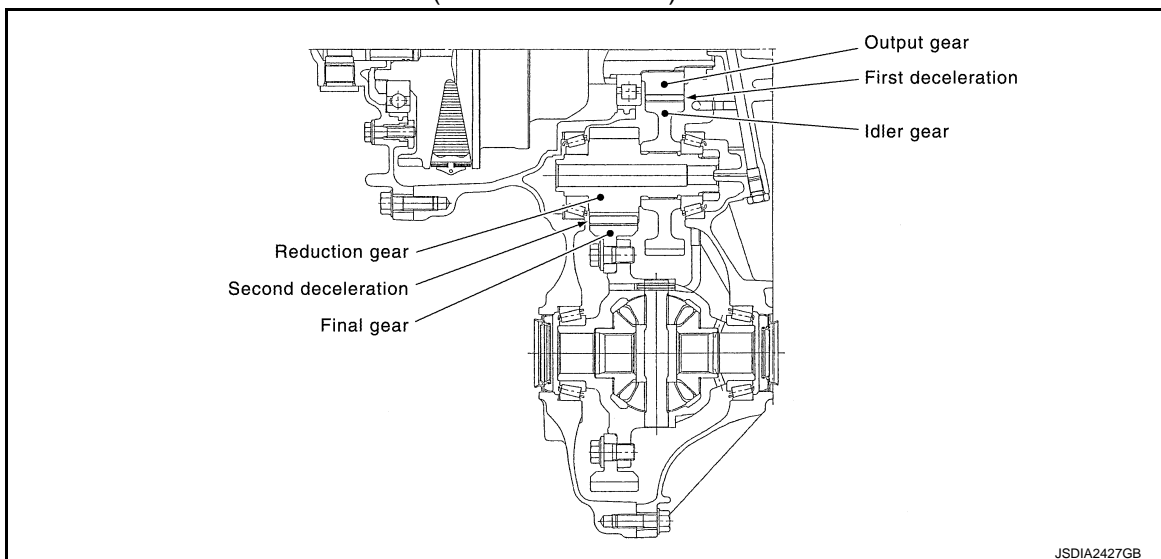

# STRUCTURE AND OPERATION

< SYSTEM DESCRIPTION >

[CVT: RE0F10B]

## TRANSAXLE : Belt & Pulley

INFOID:00000009752518

### STRUCTURE

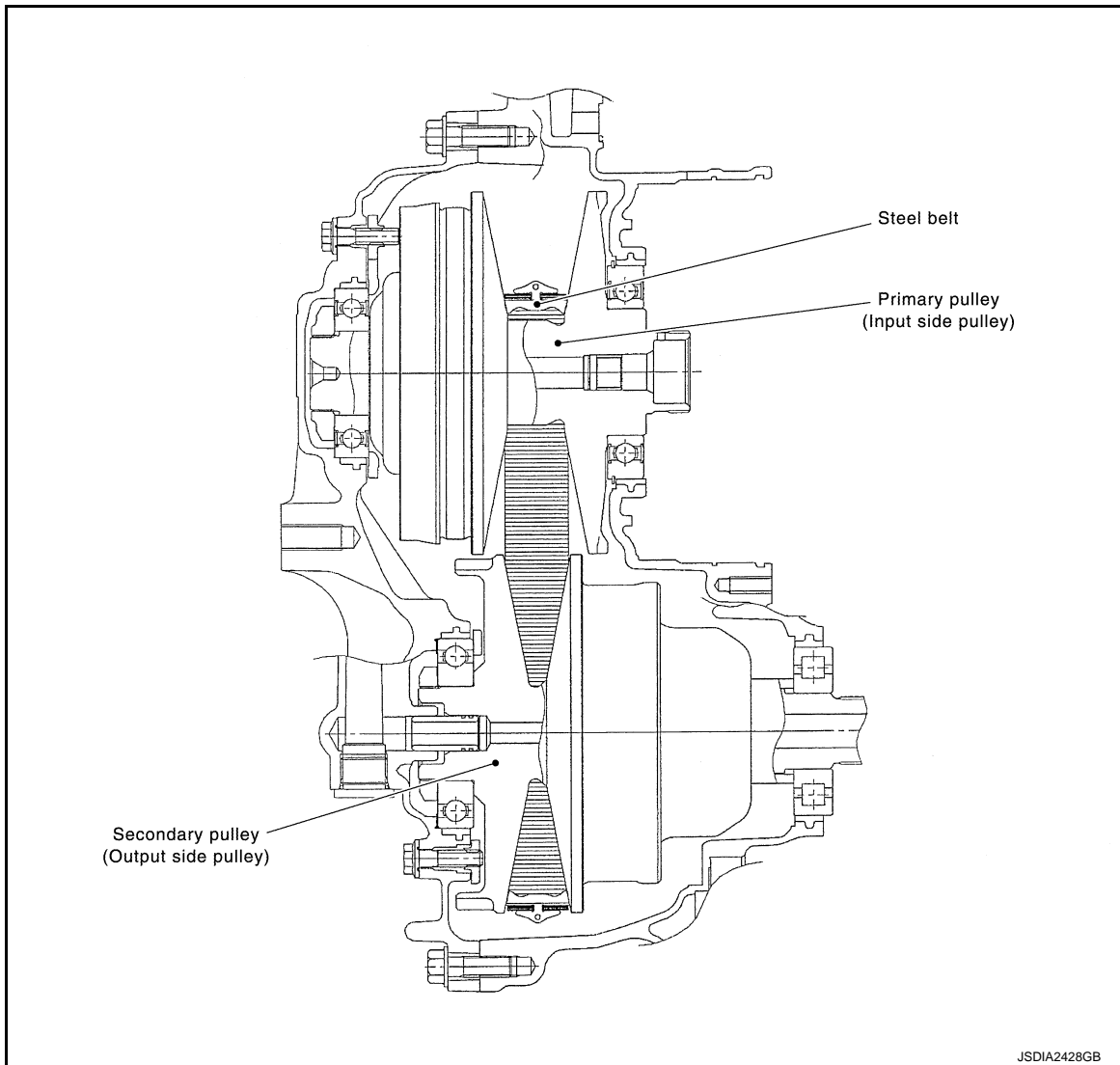

### MECHANISM

It is composed of a pair of pulleys (the groove width is changed freely in the axial direction) and the steel belt (the steel plates are placed continuously and the belt is guided with the multilayer steel rings on both sides). The groove width changes according to wrapping radius of steel belt and pulley from low status to overdrive status continuously with non-step. It is controlled with the oil pressures of primary pulley and secondary pulley.

### STEEL BELT

It is composed of multiple steel plates (A) and two steel rings (B) stacked to a several number. The feature of this steel belt transmits power with compression of the steel plate in contrast with transmission of power in pulling with a rubber belt. Friction force is required with the pulley slope to transmit power from the steel plate. The force is generated with the following mechanism:

Oil pressure applies to the secondary pulley to nip the plate. ⇒The plate is pushed and extended outward. ⇒The steel ring shows withstands. ⇒Pulling force is generated on the steel ring. ⇒The plate of the primary pulley is nipped between the pulley. ⇒Friction force is generated between the steel belt and the pulley.

Therefore, responsibilities are divided by the steel plate that transmits the power with compression and the steel ring that maintains necessary friction force. In this way, the

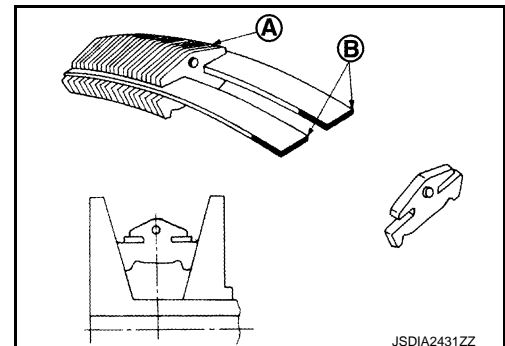



# STRUCTURE AND OPERATION

< SYSTEM DESCRIPTION >

[CVT: RE0F10B]

tension of the steel ring is distributed on the entire surface and stress variation is limited, resulting in good durability.

## PULLEY

The primary pulley (input shaft side) and the secondary pulley (output shaft side) have the shaft with slope (fixed cone surface), movable sheave (movable cone surface that can move in the axial direction) and oil pressure chamber at the back of the movable sheave.

The movable sheave slides on the shaft to change the groove width of the pulley. Input signals of engine load (accelerator pedal opening), primary pulley speed and secondary pulley speed change the operation pressures of the primary pulley and the secondary pulley, and controls the pulley groove width.

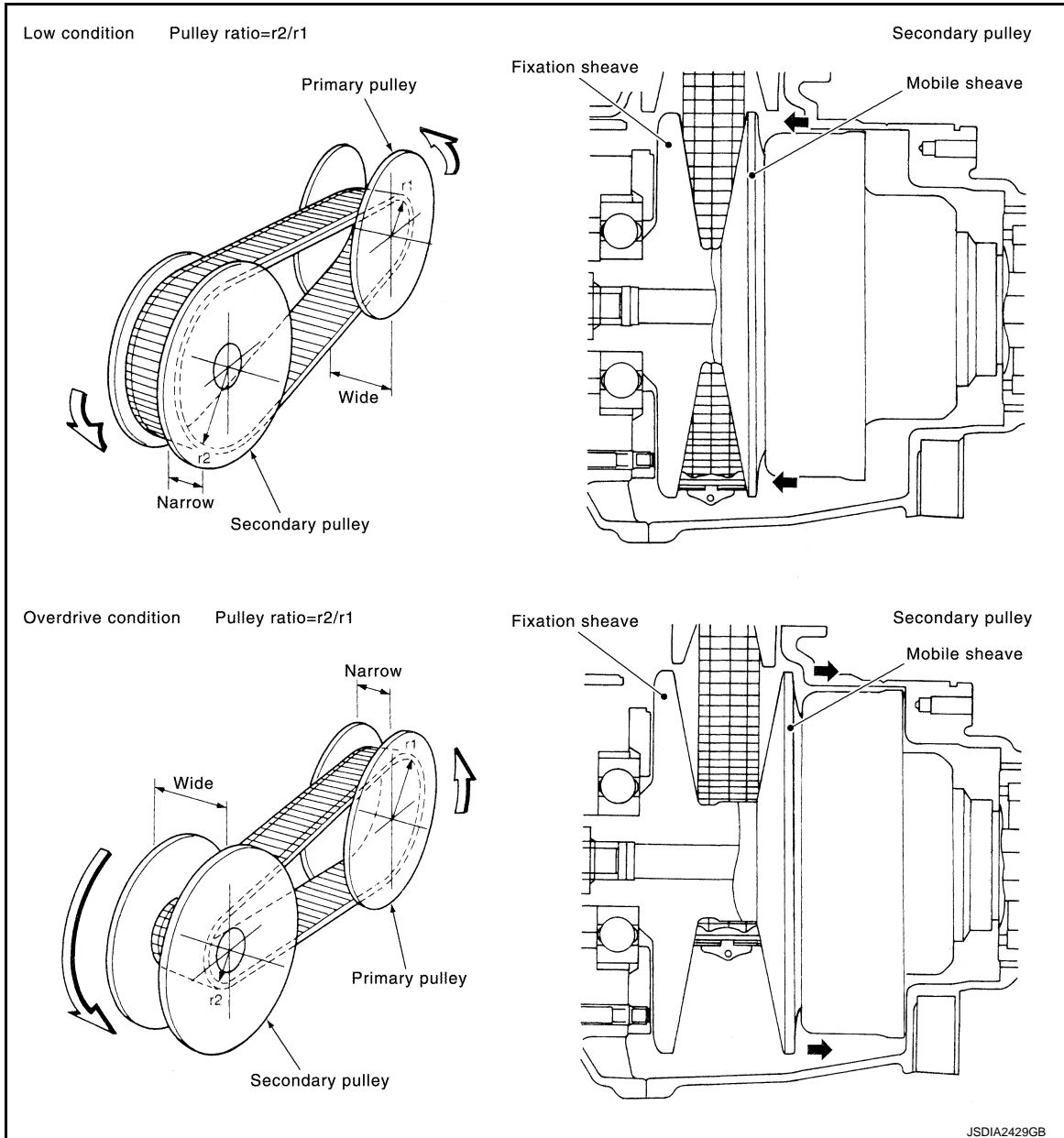

## FLUID COOLER & FLUID WARMER SYSTEM

### FLUID COOLER & FLUID WARMER SYSTEM : System Description

INFOID:000000009752519

### CVT FLUID COOLER SCHEMATIC

A  
B  
C  
TM  
E  
F  
G  
H  
I  
J  
K  
L  
M  
N  
O  
P

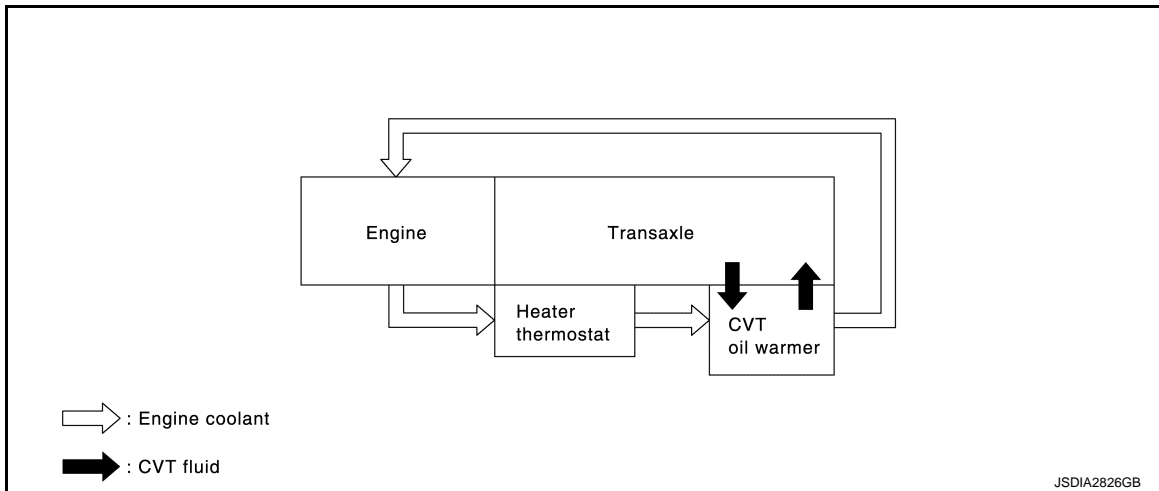

## COMPONENT DESCRIPTION

### CVT Oil Warmer

- The CVT oil warmer (1) is installed on the front part of transaxle assembly.
- When engine is started while engine and CVT are cold, engine coolant temperature rises more quickly than CVT fluid temperature. CVT oil warmer is provided with two circuits for CVT and engine coolant respectively so that warmed engine coolant warms CVT quickly. This helps shorten CVT warming up time, improving fuel economy.
- A cooling effect is obtained when A/T fluid temperature is high.

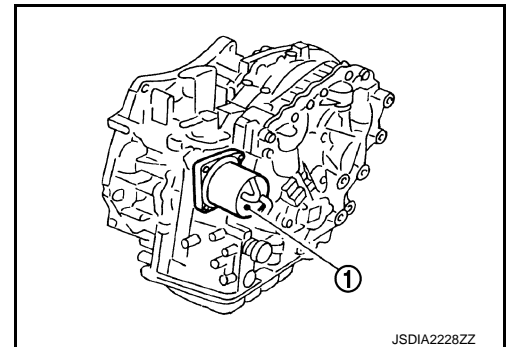

### Heater Thermostat

The heater thermostat (1) is installed on the front part of transaxle assembly.

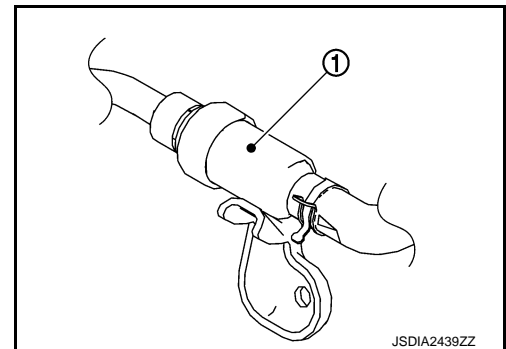

## MECHANICAL SYSTEM

# STRUCTURE AND OPERATION

< SYSTEM DESCRIPTION >

[CVT: RE0F10B]

## MECHANICAL SYSTEM : System Diagram

INFOID:000000009752520

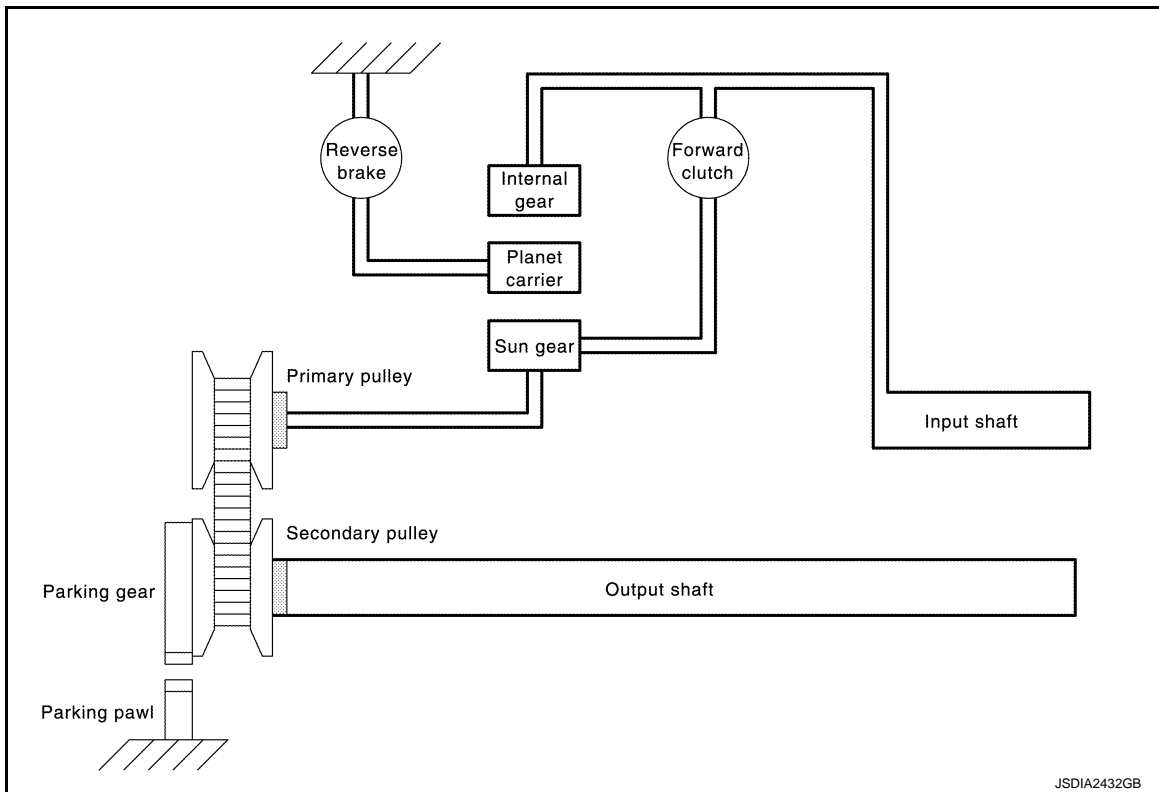

## MECHANICAL SYSTEM : System Description

INFOID:000000009752521

Traction force of engine is transmitted to wheel via torque converter, planetary gear, belt, pulley, differential gear, and others. Also includes a parking mechanism that mechanically fixes secondary pulley when selector lever is shifted to the “P” position.

## ACTIVATION STATE ACCORDING TO EACH SHIFTING

×: Operates

Selector lever position	Secondary pressure sensor	Solenoid valve				Step motor
		Line pressure solenoid valve	Secondary pressure solenoid valve	Torque converter solenoid valve	Lock-up select solenoid valve	
P	×	×	×		×	
R	×	×	×		×	×
N	×	×	×		×	×
D (Low)	×	×	×	×		×
D (High)	×	×	×	×		×
D (Lock-up)	×	×	×	×		×

## POWER TRANSMISSION

“P” position

- Traction force from input shaft is not transmitted to primary pulley because forward clutch and reverse brake are not engaged and run idle.
- Torque from the wheels is not transmitted to secondary pulley because secondary pulley is mechanically fixed when parking pole that is linked with selector lever is engaged with parking gear that is integrated with secondary pulley.

# STRUCTURE AND OPERATION

< SYSTEM DESCRIPTION >

[CVT: RE0F10B]

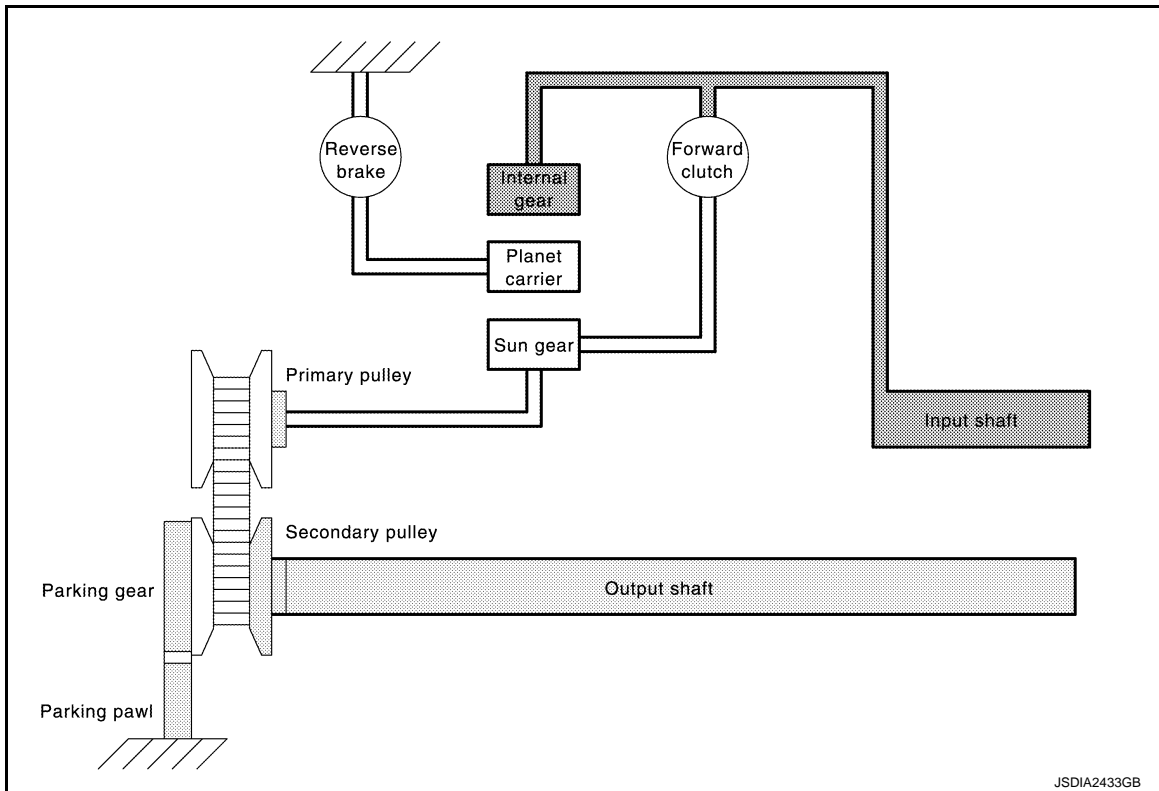

JSDIA2433GB

## Planetary gear

Name	Sun gear	Planet carrier	Internal gear
Condition	Stop	Idled	Input
Direction of rotation	—	—	Clockwise revolution

## “R” position

- Traction force from input shaft rotates sun gear in opposite direction of input shaft rotation because reverse brake is engaged and planetary gear is fixed.
- Therefore primary pulley rotates in opposite direction of input shaft rotation and traction force output is in opposite direction rotation.

# STRUCTURE AND OPERATION

< SYSTEM DESCRIPTION >

[CVT: RE0F10B]

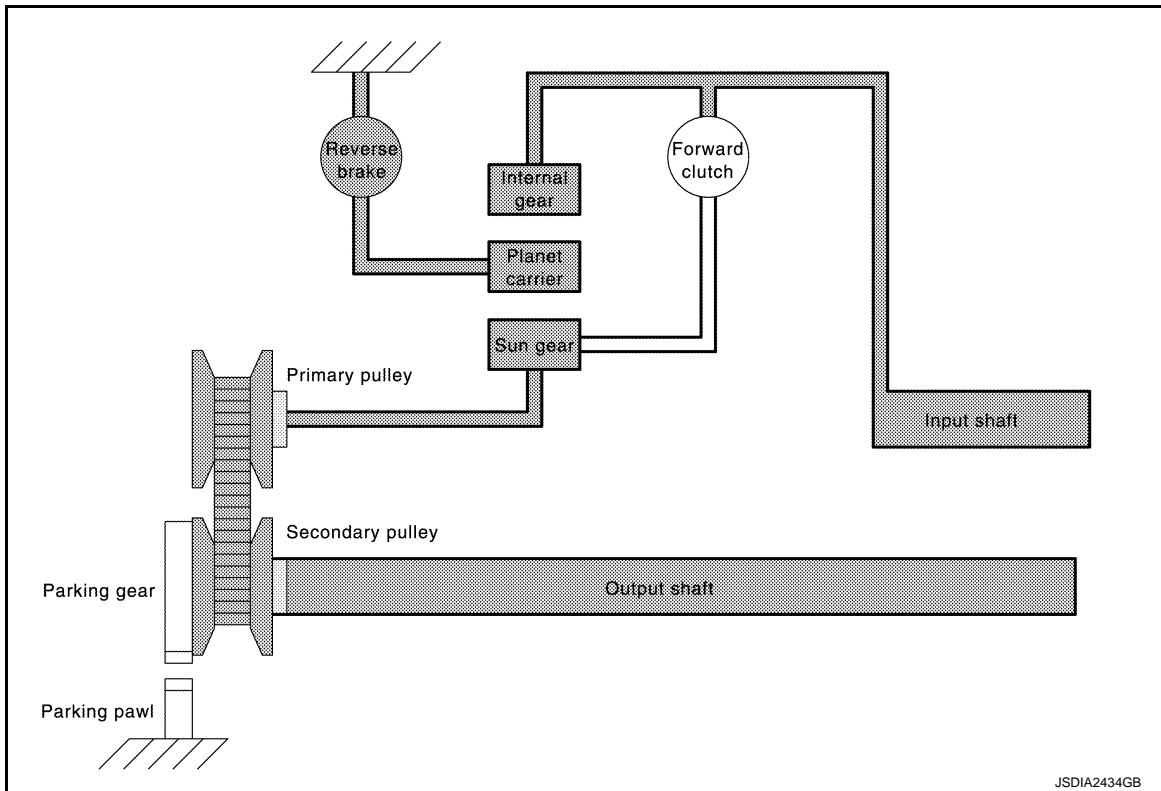

Planetary gear

Name	Sun gear	Planet carrier	Internal gear
Condition	Output	Fixed	Input
Direction of rotation	Counterclockwise revolution	—	Clockwise revolution

“N” position

- Traction force from input shaft is not transmitted to primary pulley because forward clutch and reverse brake are not engaged and run idle.
- Torque from wheel is not transmitted to input shaft because forward clutch and reverse brake are not engaged and planetary carrier runs idle.

A  
B  
C  
TM  
E  
F  
G  
H  
I  
J  
K  
L  
M  
N  
O  
P

# STRUCTURE AND OPERATION

< SYSTEM DESCRIPTION >

[CVT: RE0F10B]

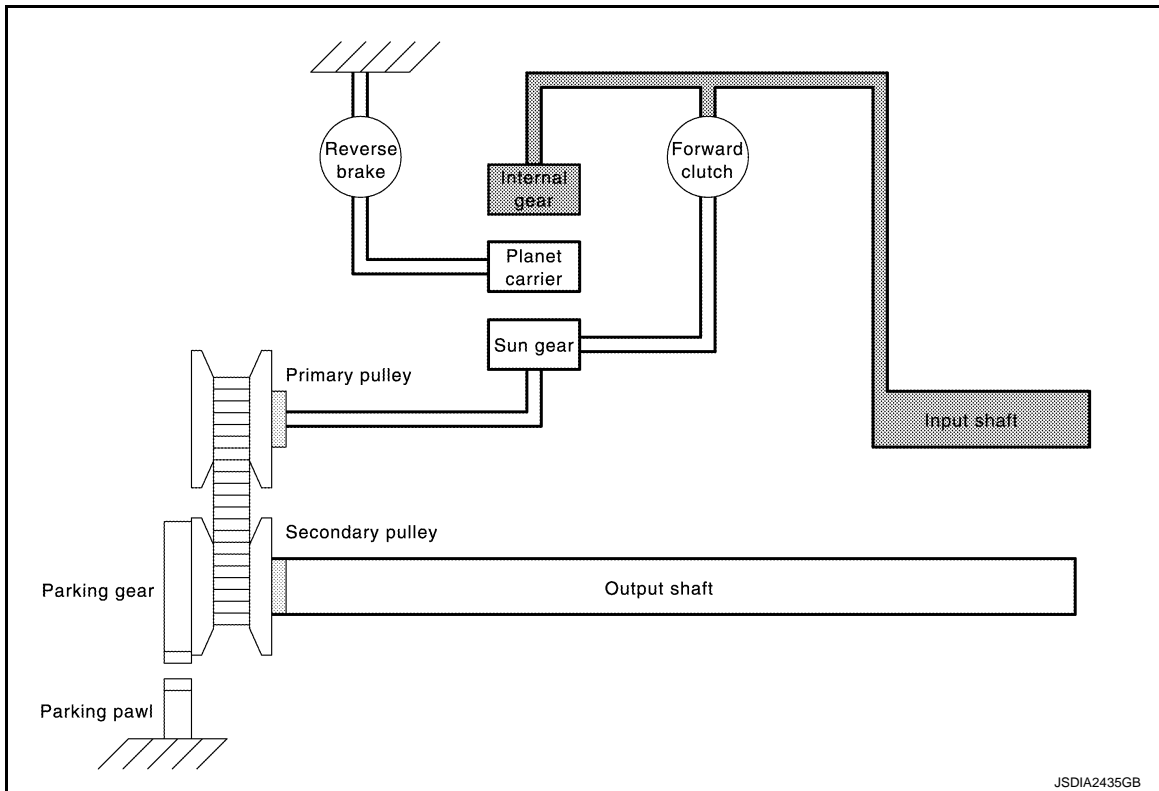

Planetary gear

Name	Sun gear	Planet carrier	Internal gear
Condition	Stop	Idle	Input
Direction of rotation	—	—	Clockwise revolution

“D” position

- Traction force from input shaft rotates sun gear via forward clutch in the same direction of input shaft because forward clutch is engaged.
- Therefore primary pulley rotates in the same direction of input shaft rotation and traction force output is in the same direction rotation.

# STRUCTURE AND OPERATION

< SYSTEM DESCRIPTION >

[CVT: RE0F10B]

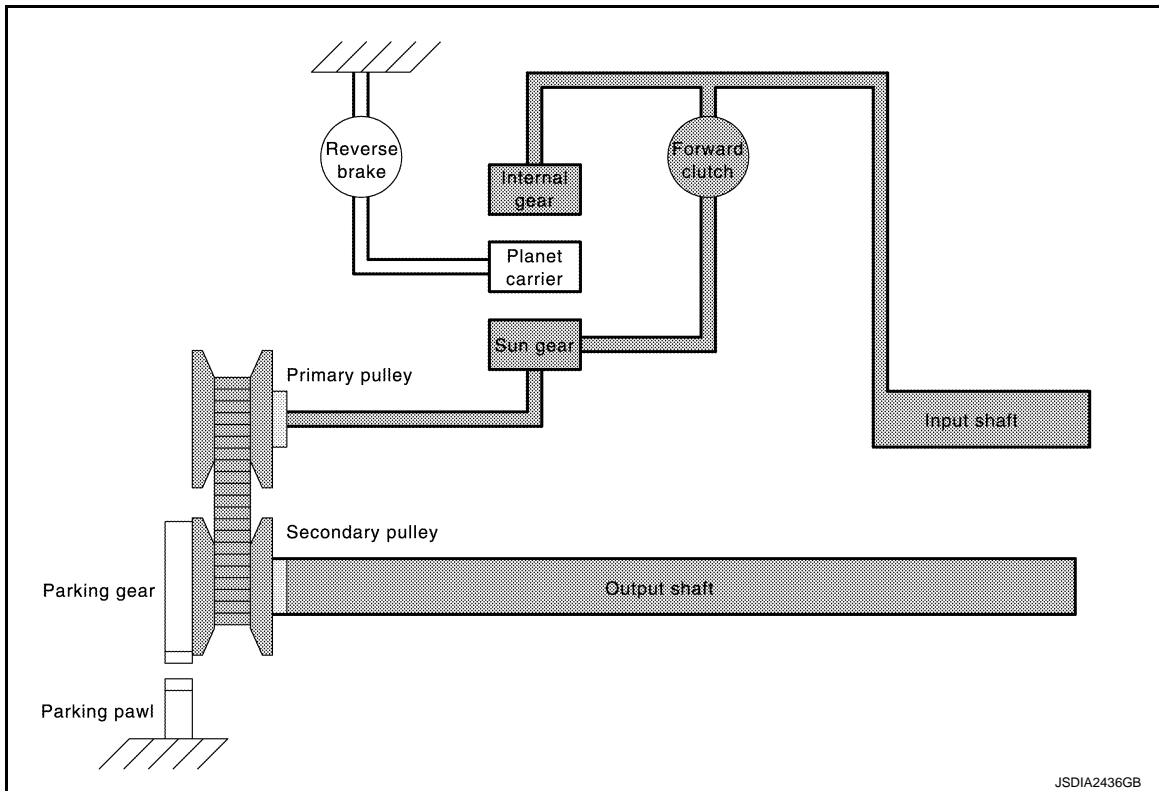

Planetary gear

Name	Sun gear	Planet carrier	Internal gear
Condition	Input/output	Idle	Input
Direction of rotation	Clockwise revolution	—	Clockwise revolution

## MECHANICAL SYSTEM : Component Description

INFOID:000000009752522

Part name	Function
Torque converter	Increases engine torque and transmits it to the transaxle.
Oil pump	Utilizes a vane-type oil pump that is driven by the engine through the oil pump drive chain in order to increase efficiency of pump discharge volume in low-speed zone and optimize pump discharge volume in high-speed zone. Discharged oil from oil pump is transmitted to control valve. It is used as the oil of primary and secondary pulley operation, the oil of clutch operation, and the lubricant for each part.
Forward clutch	The forward clutch is wet and multiple plate type clutch that consists of clutch drum, piston, drive plate, and driven plate. It is a clutch to move the vehicle forward by activating piston hydraulically, engaging plates, and directly connecting sun gear and input shaft.
Reverse brake	The reverse brake is a wet multiple-plate type brake that consists of transaxle case, piston, drive plate, and driven plate. It is a brake to move the vehicle in reverse by activating piston hydraulically, engaging plates, and fixing planetary gear.
Internal gear	The internal gear is directly connected to forward clutch drum. It is a gear that moves the outer edge of pinion planet of planet carrier. It transmits power to move the vehicle in reverse when the planet carrier is fixed.
Planet carrier	Composed of a carrier, pinion planet, and pinion shaft. This gear fixes and releases the planet carrier in order to switch between forward and reverse driving.
Sun gear	Sun gear is a set part with planet carrier and internal gear. It transmits transmitted force to primary fixed sheave. It rotates in forward or reverse direction according to activation of either forward clutch or reverse brake.
Input shaft	The input shaft is directly connected to forward clutch drum and transmits traction force from torque converter. In shaft center, there are holes for hydraulic distribution to primary pulley and hydraulic distribution for lockup ON/OFF.

# STRUCTURE AND OPERATION

< SYSTEM DESCRIPTION >

[CVT: RE0F10B]

Part name	Function
Primary pulley	It is composed of a pair of pulleys (the groove width is changed freely in the axial direction) and the steel belt (the steel plates are placed continuously and the belt is guided with the multilayer steel rings on both sides). The groove width changes according to wrapping radius of steel belt and pulley from low status to overdrive status continuously with non-step. It is controlled with the oil pressures of primary pulley and secondary pulley.
Secondary pulley	
Steel belt	
Manual shaft	When the manual shaft is in the P position, the parking rod that is linked to the manual shaft rotates the parking pole. When the parking pole rotates, it engages with the parking gear, fixing the parking gear. As a result, the secondary pulley that is integrated with the parking gear is fixed.
Parking rod	
Parking pawl	
Parking gear	
Output gear	The deceleration gears are composed of 2 stages: primary deceleration (output gear, idler gear pair) and secondary deceleration (reduction gear, final gear pair). All of these gears are helical gears.
Idler gear	
Reduction gear	
Differential	
Torque converter regulator valve	Adjusts the feed pressure to the torque converter to the optimum pressure corresponding to the driving condition.
Pressure regulator valve	Adjusts the discharge pressure from the oil pump to the optimum pressure (line pressure) corresponding to the driving condition.
Torque converter clutch control valve	Adjusts the torque converter engage and disengage pressures.
Shift control valve	Controls the line pressure that is applied to the primary pulley according to the stroke difference between the step motor and primary pulley.
Secondary valve	Reduces the line pressure and adjusts the secondary pressure.
Clutch regulator valve	Adjusts the clutch operating pressure according to the driving conditions.
Manual valve	Distributes the clutch operation pressure to each circuit according to the selector lever position.
Select control valve	Engages when selected. Adjusts the forward clutch pressure and reverse brake pressure.
Select switch valve	Performs switching control of the torque converter clutch solenoid valve control pressure when lock-up is engaged/disengaged, and when the forward/reverse clutches (forward clutch and reverse brake) are engaged/disengaged.
Step motor	<ul style="list-style-type: none"> <li>• Step motor changes step by turning 4 coils ON or OFF according to signal from TCM.</li> <li>• By changing step, step motor controls outward flow and inward flow of line pressure to primary pulley, determines the primary pulley position, and controls gear ratio.</li> </ul>



SYSTEM  
CVT CONTROL SYSTEM

CVT CONTROL SYSTEM : System Description

INFOID:000000009752523

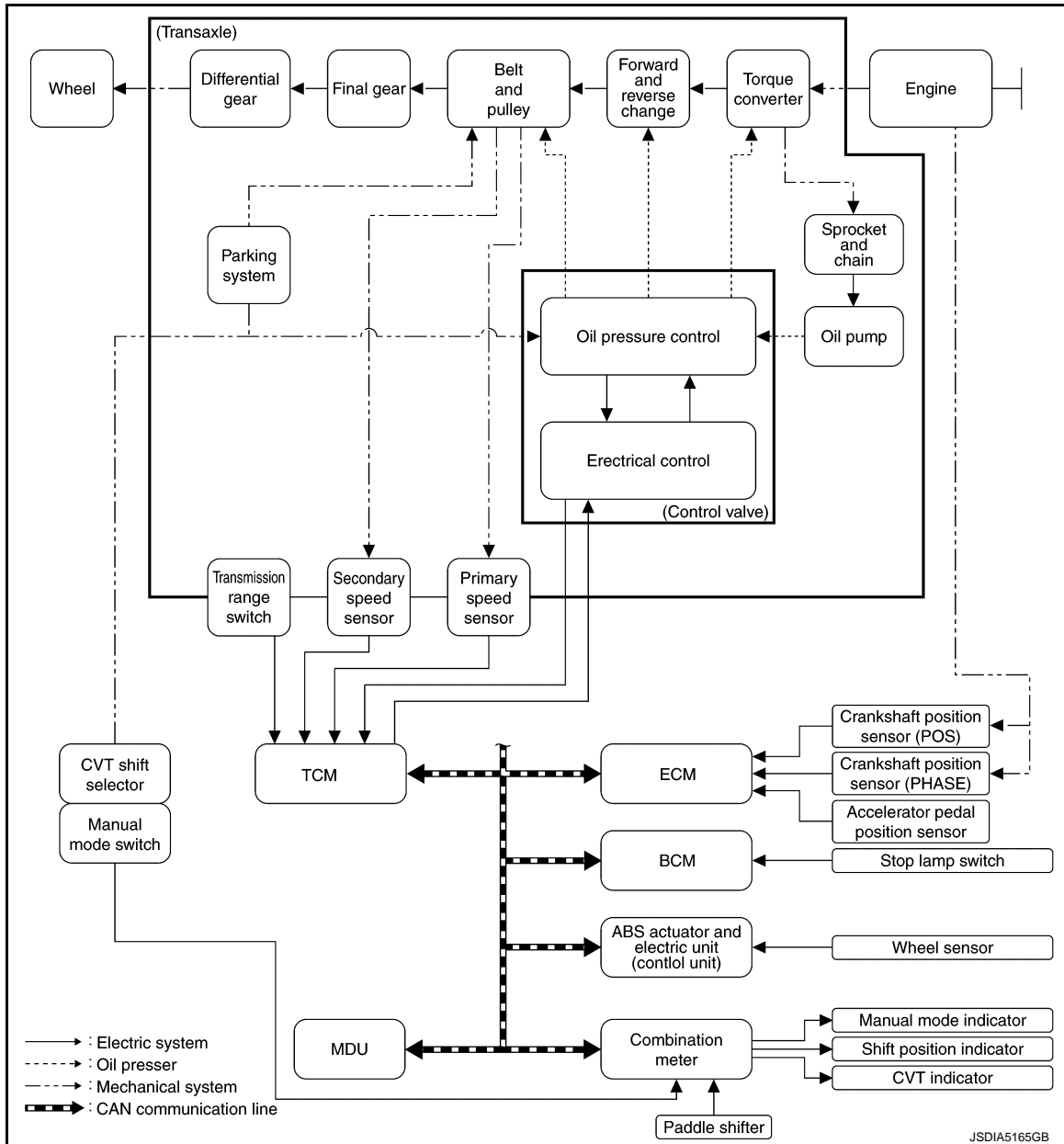

NOTE:

- MDU is applied to vehicle with Integrated Control System.
- Paddle shifter is applied to NISMO RS models.

A  
B  
C  
TM  
E  
F  
G  
H  
I  
J  
K  
L  
M  
N  
O  
P

CVT CONTROL SYSTEM : System Diagram

INFOID:000000009752524

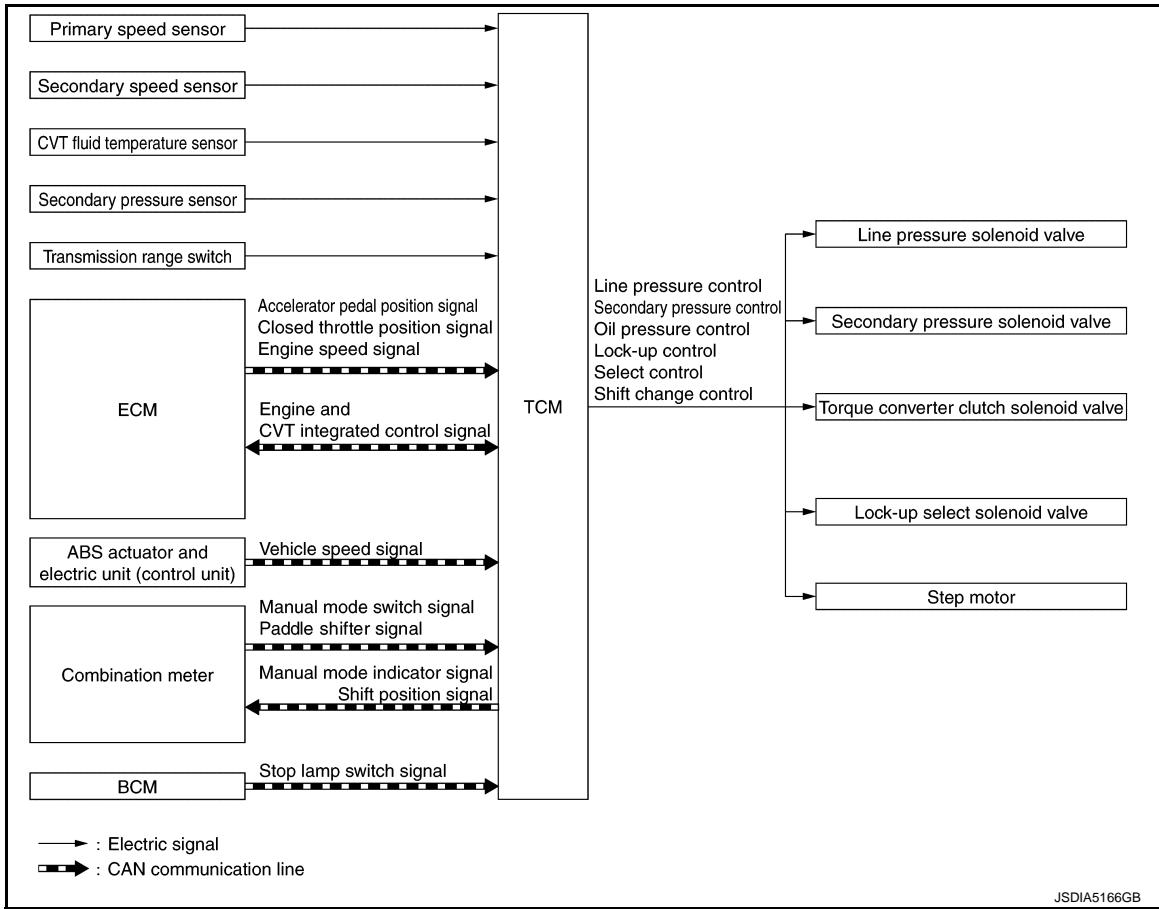

NOTE:

Paddle shifter is applied to NISMO RS models.

CVT CONTROL SYSTEM : Fail-Safe

INFOID:000000009752525

The TCM has an electrical fail-safe mode. In this mode TCM is operator even if there is an error in a main electronic control input/output signal circuit.

DESCRIPTION

When a malfunction is detected in each sensor, switch, solenoid or others, this function provides control to minimize reduction of drivability so that durability of transmission assembly can be acquired.

DTC	Condition	Vehicle behavior
P0703	—	<ul style="list-style-type: none"> <li>Start is slow</li> <li>Acceleration is slow</li> </ul>
P0705	—	<ul style="list-style-type: none"> <li>Position indicator on combination meter is not displayed</li> <li>Selector shock is large</li> <li>Start is slow</li> <li>Acceleration at high load state is slow</li> <li>Manual mode is not activated</li> <li>Lock-up is not performed</li> </ul>

# SYSTEM

< SYSTEM DESCRIPTION >

[CVT: RE0F10B]

DTC	Condition	Vehicle behavior	
P0710	Engine coolant temperature when engine starts is 10°C (50°F) or more	Start is slow	A
	Engine coolant temperature when engine starts is 10°C (50°F) or less	<ul style="list-style-type: none"> <li>• Start is slow</li> <li>• Acceleration is slow</li> <li>• Vehicle speed is not increased</li> </ul>	B
	Engine coolant temperature when engine starts is -35°C (-31°F) or less	Vehicle speed is not increased	C
P0715	—	<ul style="list-style-type: none"> <li>• Acceleration is slow</li> <li>• Re-start is slow after vehicle is stop by strong deceleration</li> <li>• Manual mode is not activated</li> <li>• Lock-up is not performed</li> </ul>	TM
P0720	—	<ul style="list-style-type: none"> <li>• Start is slow</li> <li>• Acceleration is slow</li> <li>• Re-start is slow after vehicle is stop by strong deceleration</li> </ul>	E
		<ul style="list-style-type: none"> <li>• Manual mode is not activated</li> <li>• Lock-up is not performed</li> </ul>	F
P0725	—	Lock-up is not performed	
P0740	—	<ul style="list-style-type: none"> <li>• Selector shock is large</li> <li>• Lock-up is not performed</li> </ul>	G
P0744	—	Lock-up is not performed	
P0746	A malfunction is detected	<ul style="list-style-type: none"> <li>• Start is slow</li> <li>• Acceleration is slow</li> <li>• Lock-up is not performed</li> </ul>	H
	Function is excessively reduced after a malfunction is detected	<ul style="list-style-type: none"> <li>• Start is difficult</li> <li>• Drive is difficult</li> <li>• Lock-up is not performed</li> </ul>	I
P0778	—	Vehicle speed is not increased	J
P0826	—	Manual mode is not activated	
P0840	—	<ul style="list-style-type: none"> <li>• Start is slow</li> <li>• Acceleration is slow</li> </ul>	K
P0841	—	<ul style="list-style-type: none"> <li>• Start is slow</li> <li>• Acceleration is slow</li> </ul>	
P0845	—	<ul style="list-style-type: none"> <li>• Start is slow</li> <li>• Acceleration is slow</li> </ul>	L
P0868	—	<ul style="list-style-type: none"> <li>• Start is slow</li> <li>• Acceleration is slow</li> </ul>	M
P1701	—	<ul style="list-style-type: none"> <li>• Start is slow</li> <li>• Acceleration is slow</li> </ul>	
P1705	—	<ul style="list-style-type: none"> <li>• Acceleration is slow</li> <li>• Lock-up is not performed</li> </ul>	N
P1709	—	<ul style="list-style-type: none"> <li>• Start is slow</li> <li>• Acceleration is slow</li> <li>• Shift position indicator (P, N) is not displayed, or is displayed with delay.</li> </ul>	O
P1722	—	Lock-up is not activated in coast state	P

# SYSTEM

< SYSTEM DESCRIPTION >

[CVT: RE0F10B]

DTC	Condition	Vehicle behavior
P1723	A malfunction is detected in primary pulley speed sensor side	<ul style="list-style-type: none"> <li>• Acceleration is slow</li> <li>• Re-start is slow after vehicle is stop by strong deceleration</li> <li>• Manual mode is not activated</li> <li>• Lock-up is not performed</li> </ul>
	A malfunction is detected in secondary pulley speed sensor	<ul style="list-style-type: none"> <li>• Start is slow</li> <li>• Acceleration is slow</li> <li>• Re-start is slow after vehicle is stop by strong deceleration</li> <li>• Manual mode is not activated</li> <li>• Lock-up is not performed</li> </ul>
P1726	—	Acceleration is slow
P1740	—	<ul style="list-style-type: none"> <li>• Selector shock is large</li> <li>• Lock-up is not performed</li> </ul>
P1777	A malfunction is detected in low side (when vehicle is stopped)	<ul style="list-style-type: none"> <li>• Vehicle speed is not increased</li> <li>• Lock-up is not performed</li> </ul>
	A malfunction is detected in high side (during driving)	<ul style="list-style-type: none"> <li>• Start is slow</li> <li>• Acceleration is slow</li> <li>• Lock-up is not performed</li> </ul>
U0100	—	<ul style="list-style-type: none"> <li>• Start is slow</li> <li>• Acceleration is slow</li> <li>• Vehicle speed is not increased</li> </ul>
U1000	—	<ul style="list-style-type: none"> <li>• Start is slow</li> <li>• Acceleration is slow</li> <li>• Vehicle speed is not increased</li> </ul>
U1010	—	<ul style="list-style-type: none"> <li>• Start is slow</li> <li>• Acceleration is slow</li> <li>• Vehicle speed is not increased</li> </ul>

## OIL PRESSURE CONTROL SYSTEM

OIL PRESSURE CONTROL SYSTEM : System Diagram

INFOID:000000009752526

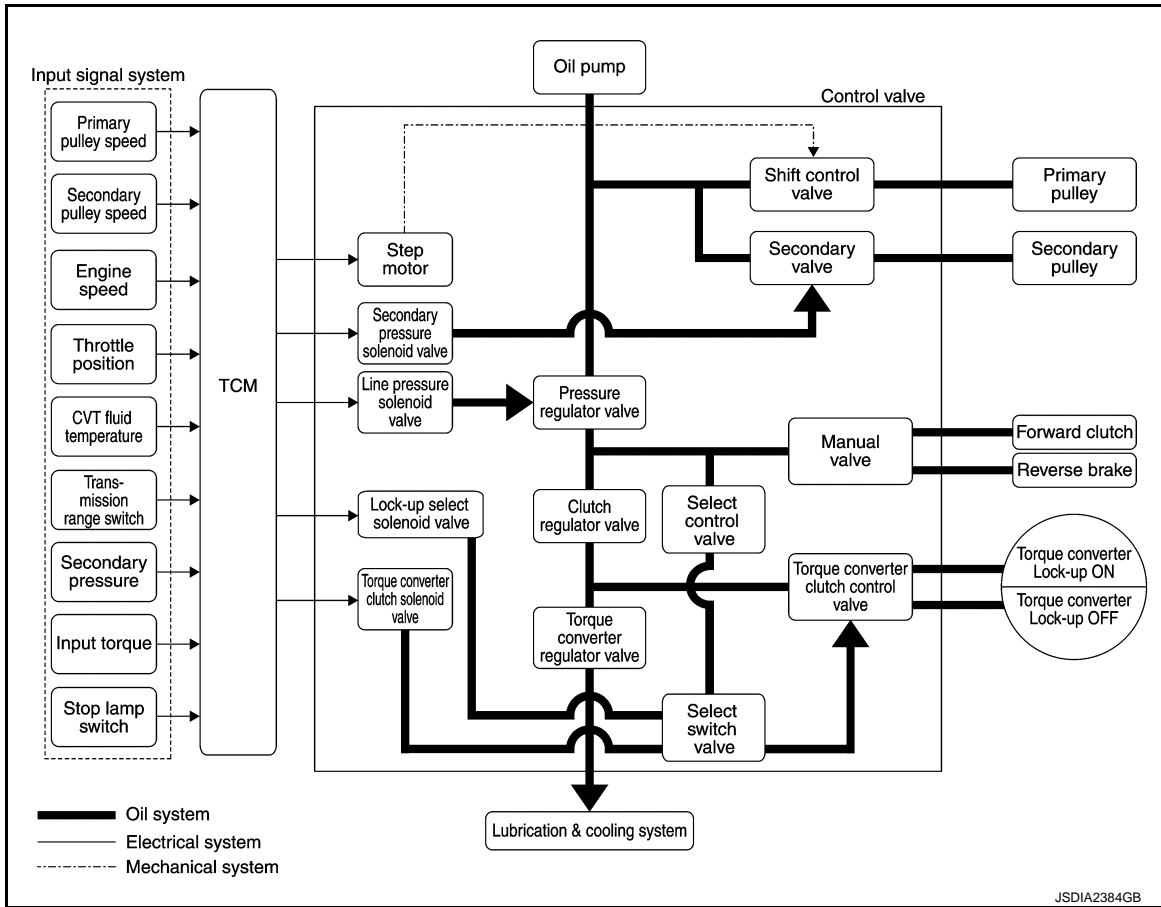

OIL PRESSURE CONTROL SYSTEM : System Description

INFOID:000000009752527

The hydraulic control mechanism consists of the oil pump directly driven by the engine, the hydraulic control valve that controls line pressure and transmission, and the input signal line.

LINE PRESSURE AND SECONDARY PRESSURE CONTROL

- When an input torque signal equivalent to the engine driving force is transmitted from the ECM to the TCM, the TCM controls the line pressure solenoid valve and secondary pressure solenoid valve.
- Highly accurate line pressure control and secondary pressure control reduces friction for improvement of fuel economy.

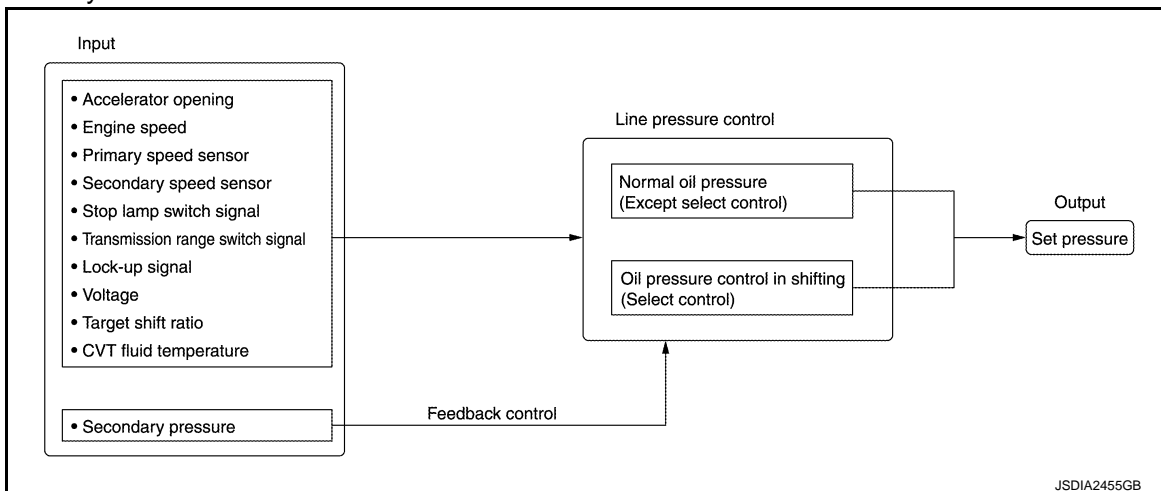

Normal Oil Pressure Control

# SYSTEM

< SYSTEM DESCRIPTION >

[CVT: RE0F10B]

Appropriate line pressure and secondary pressure suitable for driving condition are determined based on the accelerator pedal position, engine speed, primary pulley (input) speed, secondary pulley (output) speed, input torque, stop lamp switch signal, transmission range switch signal, lock-up signal, power voltage, target shift ratio, oil temperature and oil pressure.

## Secondary Pressure Feedback Control

In normal oil pressure control and oil pressure control in shifting, highly accurate secondary pressure is determined by detecting the secondary pressure using an oil pressure sensor and by feedback control.

## CONTROL SYSTEM

### CONTROL SYSTEM : System Diagram

INFOID:000000009752528

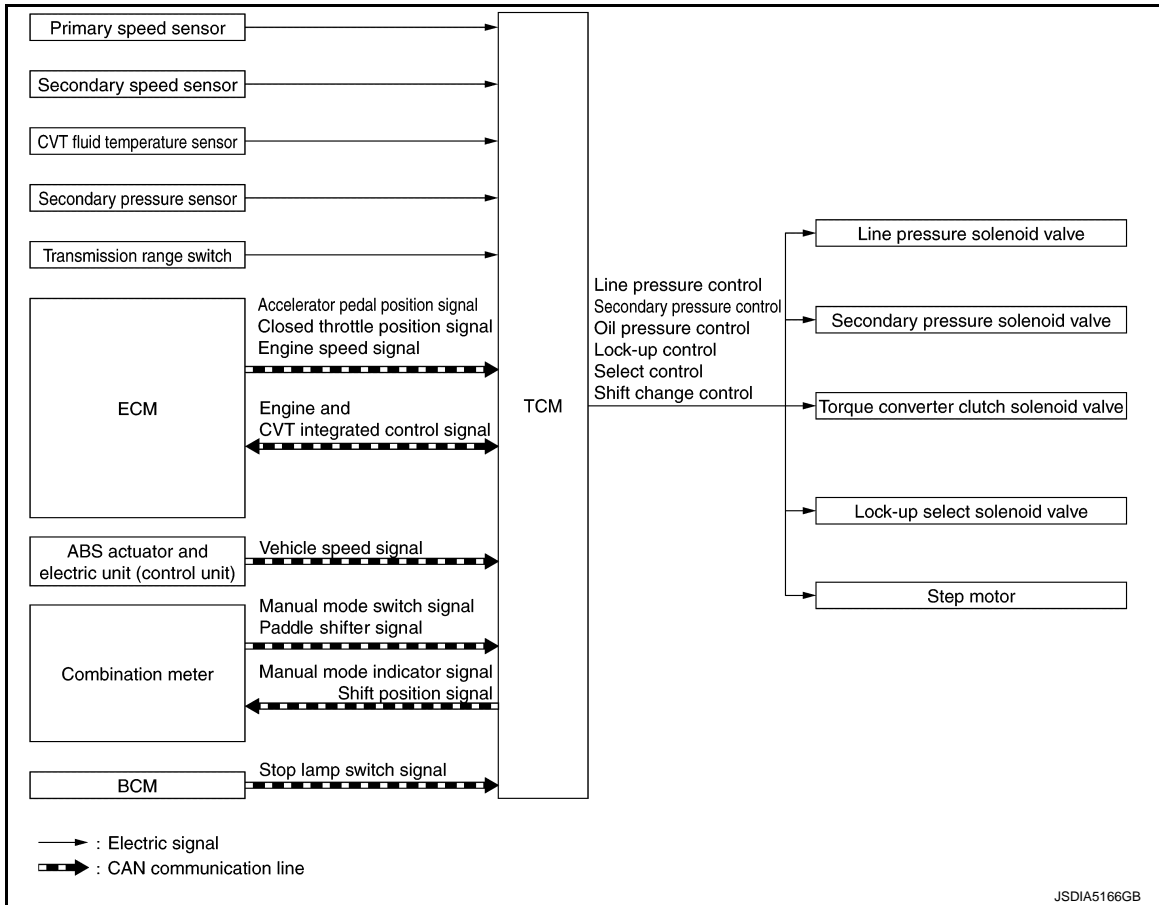

### NOTE:

Paddle shifter is applied to NISMO RS models.

### CONTROL SYSTEM : System Description

INFOID:000000009752529

The TCM senses vehicle operating conditions through various sensors or signals. It always controls the optimum shift position and reduces shifting and lock-up shocks.

### TCM FUNCTION

The function of the TCM is to:

- Receive input signals transmitted from various switches and sensors.
- Determine required line pressure, shifting point, lock-up operation, etc.
- Transmit required output signals to the respective solenoids.

# SYSTEM

< SYSTEM DESCRIPTION >

[CVT: RE0F10B]

Sensor (or signal)	⇒	TCM function	⇒	Actuator
Transmission range switch CVT fluid temperature sensor Secondary pressure sensor Primary speed sensor Secondary speed sensor Engine speed signal Accelerator pedal position signal Closed throttle position signal Stop lamp switch signal Manual mode switch signal Vehicle speed signal		Shift control Line pressure control Primary oil pressure control Secondary oil pressure control Lock-up control Engine brake control Vehicle speed control Integrated Control System Fail-safe function Self-diagnosis function Communication function with CON-SULT CAN communication control		Line pressure solenoid valve Secondary pressure solenoid valve Torque converter clutch solenoid valve Lock-up select solenoid valve Step motor Shift position indicator Manual mode indicator

## TCM INPUT/OUTPUT SIGNAL

Control item		Line pressure control	Select control	Shift control	Lock-up control	CAN communication control	Fail-safe function*2
Input	Transmission range switch	×	×	×	×	×	×
	CVT fluid temperature sensor	×	×	×	×		×
	Secondary pressure sensor	×		×			×
	Primary speed sensor	×		×	×	×	×
	Secondary speed sensor	×	×	×	×	×	×
	Engine speed signal*1	×	×		×	×	×
	Accelerator pedal position signal*1	×	×	×	×	×	×
	Closed throttle position signal*1	×		×	×	×	
	Stop lamp switch signal*1	×		×	×	×	
	Manual mode signal*1	×		×	×	×	×
	Paddle shifter*1, 3	×		×	×	×	
TCM power supply	×	×	×	×	×	×	
Output	Line pressure solenoid	×	×	×			×
	Secondary pressure solenoid	×		×			×
	Torque converter clutch solenoid		×		×		×
	Lock-up select solenoid valve		×		×		×
	Step motor			×			×

\*1: Input by CAN communications.

\*2: If these input/output signals show errors, TCM activates the fail-safe function.

\*3: NISMO RS models.

## CONTROL SYSTEM : CAN Communication

INFOID:000000009752530

- CAN (Controller Area Network) is a serial communication line for real time application. It is an on-vehicle multiplex communication line with high data communication speed and excellent malfunction detection ability. Many electronic control units are equipped onto a vehicle, and each control unit shares information and links with other control units during operation (not independent). In CAN communication, control units are connected with 2 communication lines (CAN-H and CAN-L) allowing a high rate of information transmission with less wiring. Each control unit transmits/receives data but selectively reads required data only.
- For a list of CAN communication signals, refer to [LAN-28. "CAN COMMUNICATION SYSTEM : CAN Communication Signal Chart"](#).

## CONTROL SYSTEM : Engine and CVT Integrated Control (CAN Communication Con-

trol)

INFOID:000000009752531

- For purposes including improving the feeling when shifting speeds and preventing drops in engine speed, engine output control signals are exchanged between the ECM and TCM, and real-time cooperative control is performed according to the vehicle driving conditions.
- TCM sends the sudden deceleration signal, lock-up engaged signal, torque-down request signal, and other information to ECM, and also receives the torque-down permission/prohibit signals, lock-up permission/prohibit signals, accelerator position, and other information from ECM.

## CONTROL SYSTEM : Control between CVT and Combination Meter (CAN Communication Control)

INFOID:000000009752532

TCM sends the manual mode display request, shift position indicator signal, and other information to the combination meter, and also receives the manual mode signal and other information from the combination meter.

## CONTROL SYSTEM : Control between CVT and BCM (CAN Communication Control)

INFOID:000000009752533

TCM receives signals from the stop lamp switch via BCM.

## LOCK-UP AND SELECT CONTROL SYSTEM

### LOCK-UP AND SELECT CONTROL SYSTEM : System Diagram

INFOID:000000009752534

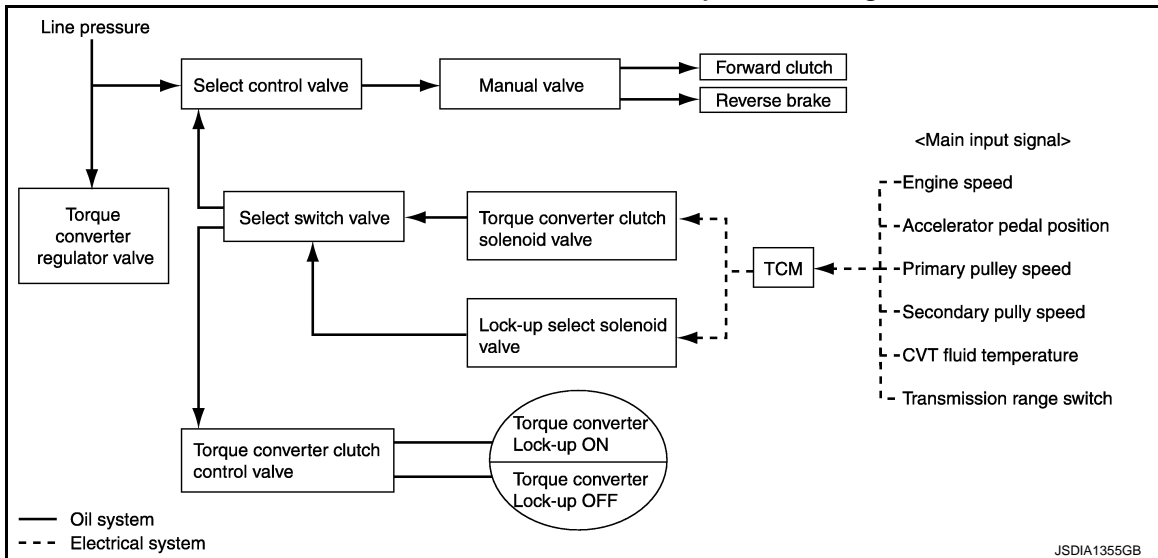

### LOCK-UP AND SELECT CONTROL SYSTEM : System Description

INFOID:000000009752535

- The torque converter clutch piston in the torque converter is engaged to eliminate torque converter slip to increase power transmission efficiency.
- The torque converter clutch control valve operation is controlled by the torque converter clutch solenoid valve, which is controlled by a signal from TCM. The torque converter clutch control valve engages or releases the torque converter clutch piston.
- When shifting between “N” (“P”) ⇒ “D” (“R”), torque converter clutch solenoid valve controls engagement power of forward clutch and reverse brake.



# SYSTEM

## < SYSTEM DESCRIPTION >

[CVT: RE0F10B]

- The lock-up applied gear range was expanded by locking up the torque converter at a lower vehicle speed than conventional A/T models.
- If the CVT fluid temperature is low or the vehicle is in fail-safe mode due to malfunction, lock-up control is prohibited.

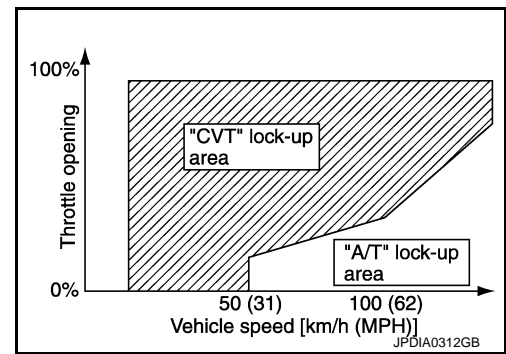

## TORQUE CONVERTER CLUTCH AND SELECT CONTROL VALVE CONTROL

### Lock-up Released

In the lock-up released state, the torque converter clutch control valve is set into the unlocked state by the torque converter clutch solenoid valve and the lock-up apply pressure is drained. In this way, the torque converter clutch piston is not coupled.

### Lock-up Applied

In the lock-up applied state, the torque converter clutch control valve is set into the locked state by the torque converter clutch solenoid valve and lock-up apply pressure is generated. In this way, the torque converter clutch piston is pressed and coupled.

### Select Control

When shifting between “N” (“P”) ⇒ “D” (“R”), optimize the operating pressure on the basis of the throttle position, the engine speed, and the secondary pulley (output) revolution speed to lessen the shift shock.

## SHIFT CONTROL SYSTEM

### SHIFT CONTROL SYSTEM : System Diagram

INFOID:000000009752536

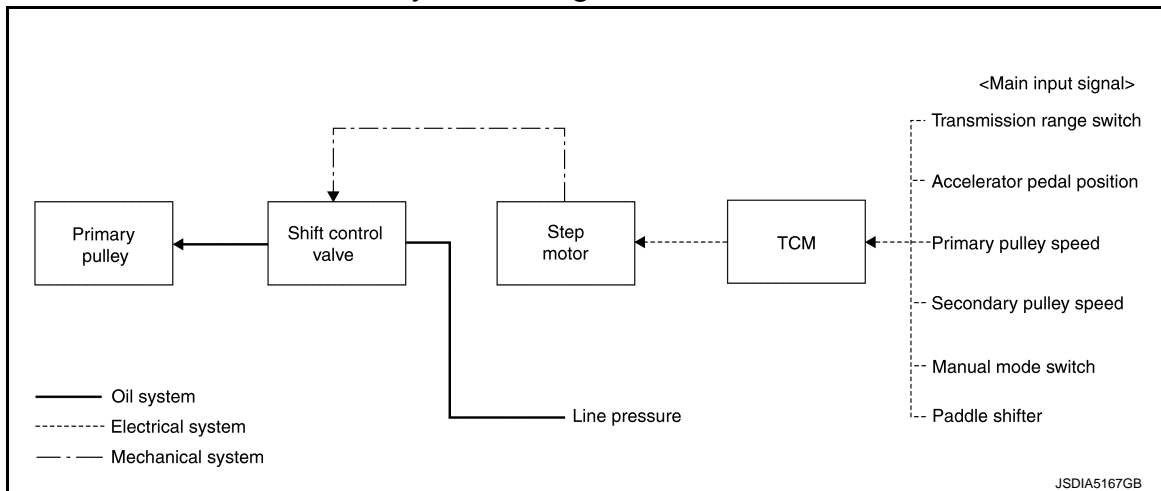

### NOTE:

- The gear ratio is set for each position separately.
- Paddle shifter is applied to NISMO RS models.

### SHIFT CONTROL SYSTEM : System Description

INFOID:000000009752537

- To select the gear ratio that can give the driving force to meet driver's intent or vehicle situation, the vehicle driving condition such as vehicle speed or accelerator pedal position is detected and the most appropriate gear ratio is selected and the shifting method before reaching the speed is determined. The information is

# SYSTEM

## < SYSTEM DESCRIPTION >

[CVT: RE0F10B]

output to the primary pressure solenoid valve to control the line pressure input/output to the primary pulley, to determine the primary pulley (movable pulley) position and to control the gear position.

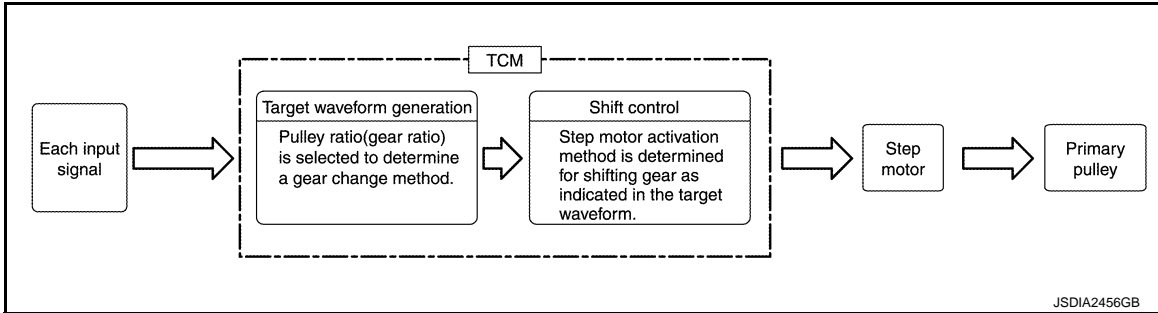

- The gear ratio is set for each position separately.

### “D” POSITION

Gear shifting is performed in all shifting ranges from the lowest to the highest gear ratio.

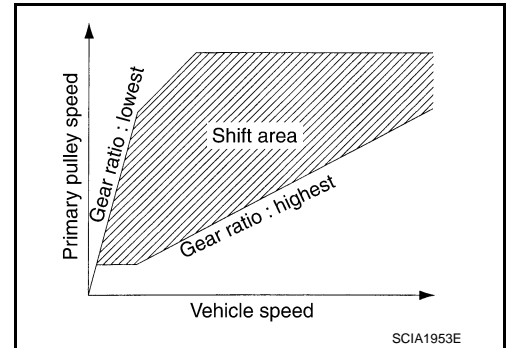

### “M” POSITION

When the selector lever or paddle shifter is put in the manual shift gate side, the fixed changing gear line is set. By moving the selector lever to + side or - side, the manual mode switch is changed over, and shift change like M/T becomes possible following the changing gear set line step by step.

- Except for NISMO RS

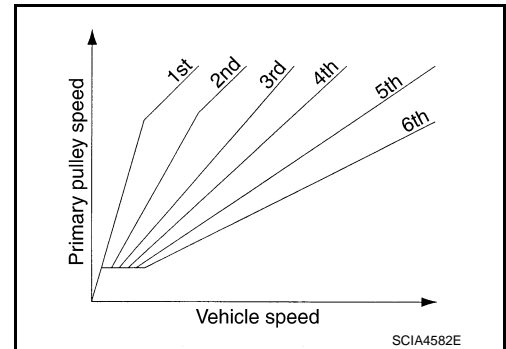

- For NISMO RS

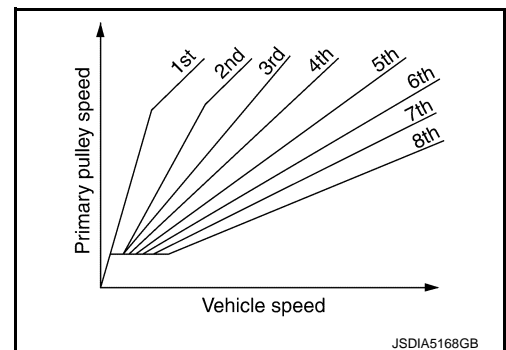

### Manual Mode Information

The TCM transmits the manual mode shift refusal signal to the combination meter if the TCM refuses the transaxle from the driving status of vehicle when the selector lever shifts to “UP (+ side)” or “DOWN (- side)” side. The combination meter blinks shift position indicator on the combination meter and sounds the buzzer to indi-

cate the driver that the shifting is not performed when receiving this signal. However, the TCM does not transmit the manual mode shift refusal signal in the conditions as per the following.

- When the selector lever or the paddle shifter shifts to “DOWN (– side)” side while driving in M1.
  - When the selector lever or the paddle shifter shifts to “UP (+ side)” side while driving in M6 (M8\*).
- \*: NISMO RS models

## BLIPPING CONTROL

Using engine torque, the blipping control enables a faster and more responsive gear shifting by compensating inertia torque generated from the rotational change during gear shifting in real time.

### Operation

- The blipping control is activated when the driver shifts up/down the transaxle in manual mode or when the transaxle is shifted up/down in “D” position SPORT mode.

**NOTE:**

The blipping control is not activated when the vehicle is in the following conditions:

- When CAN communication is abnormal.
  - During the retard inhibit signal transmission from ECM within the engine-CVT integrated control.
  - Engine coolant temperature is less than 20°C (68°F).
  - CVT fluid temperature is more than 120°C (248°F).
  - Vehicle speed is less than 20 km/h (12 MPH).
  - When ABS, TCS or VDC is active.
  - During wheel spin.
- ECM selects blipping control or normal shift control according to the gear position, the selector lever position, etc.
  - The blipping control is activated when ECM judges it controllable after receiving a control permit signal from TCM.
  - ECM controls engine torque, based on generated inertia torque.

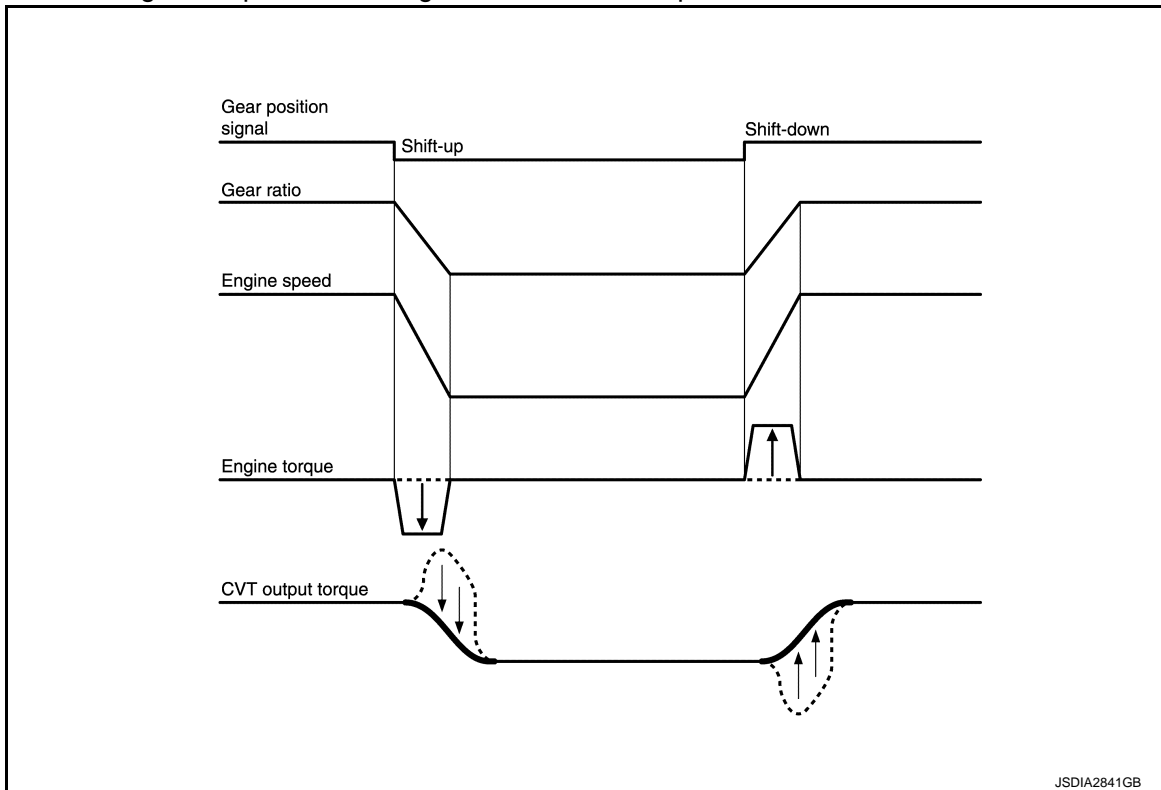

## HILL CLIMBING AND DESCENDING CONTROL

If a downhill is detected with the accelerator pedal is released, the system performs downshift to increase the engine brake force so that vehicle may not be accelerated more than necessary. If a climbing hill is detected, the system improves the acceleration performance in re-acceleration by limiting the gear shift range on the high side.

**NOTE:**

# SYSTEM

< SYSTEM DESCRIPTION >

[CVT: RE0F10B]

For engine brake control on a downhill, the control can be stopped with CONSULT.

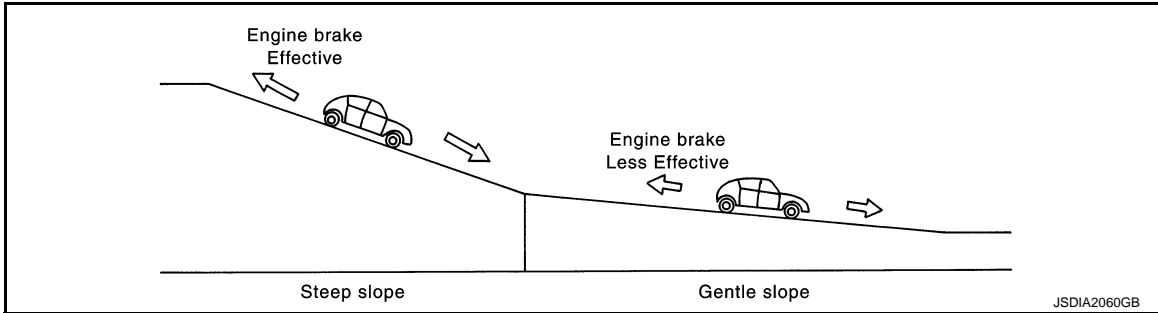

## CONTROL IN ACCELERATION

From change of the vehicle speed or accelerator pedal position, the acceleration request level of the driver or driving scene is evaluated. In start or acceleration during driving, the gear shift characteristics with linearity of revolution increase and vehicle speed increase are gained to improve the acceleration feel.

## INTEGRATED CONTROL SYSTEM

### INTEGRATED CONTROL SYSTEM : System Diagram

INFOID:000000009752538

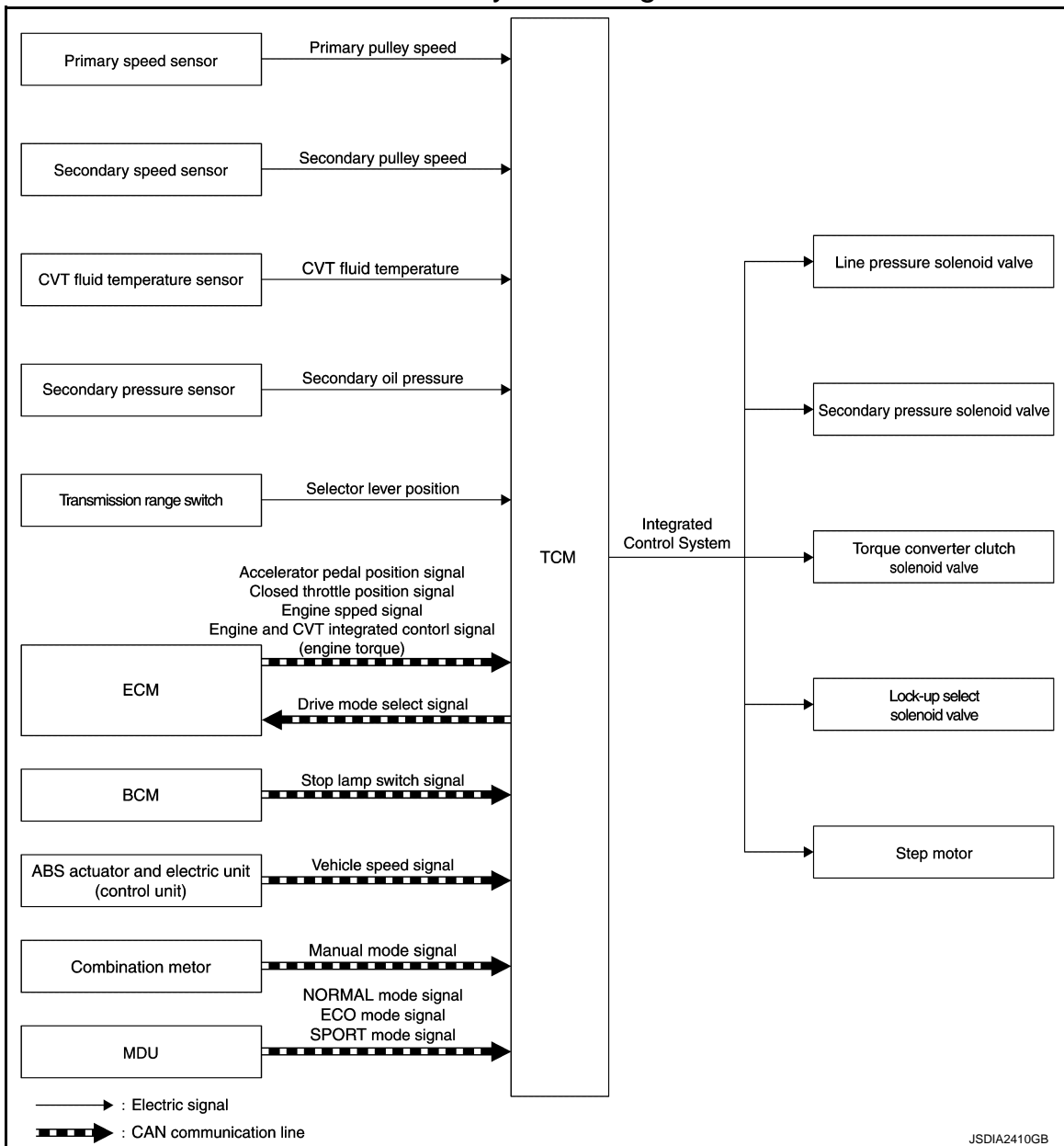

## INTEGRATED CONTROL SYSTEM : System Description

INFOID:000000009752539

- TCM receives the NORMAL mode signal, ECO mode signal or SPORT mode signal from the multi display unit through CAN communication.
- TCM sends the recognized control mode to ECM through CAN communication (drive mode select signal).
- With operation on the multi display unit, the mode is changed on the display, but the mode is actually not changed due to CAN communication malfunction.
- When the selector lever is in any position other than D position, the gear shift line is not changed according to changes in the control mode.

### CONTROL DETAILS OF EACH MODE

Control mode	Control
NORMAL mode	Driving mode that automatically selects the shift schedule considering the balance of fuel economy and driving performance based on the driving condition and driving trend.
SPORT mode	Keeps high engine speed and provides direct feel and acceleration performance suitable for driving on winding road. This driving mode also provides a rhythmical feel obtained by A/T like shifting, and produces sporty driving.
ECO mode	Driving mode that selects the shift schedule with priority on fuel economy which gives low engine revolution.

### FAIL-SAFE

If CAN communication malfunction occurs between TCM and the multi display unit, the mode when the malfunction occurs is maintained for approximately 30 seconds and the mode is changed to NORMAL mode when the accelerator pedal is released.

### SHIFT LOCK SYSTEM

#### SHIFT LOCK SYSTEM : System Description

INFOID:000000009752540

- The shift lock is the mechanism provided to prevent quick start of a vehicle by incorrect operation of a drive when the selector lever is in P position.
- Selector lever can be shifted from the P position to another position when the following conditions are satisfied.
  - Ignition switch is ON.
  - Stop lamp switch ON (brake pedal is depressed)
  - Press the selector button.

#### SHIFT LOCK OPERATION AT P POSITION

When brake pedal is not depressed (no selector operation allowed)

When the brake pedal is not depressed with the ignition switch ON, the shift lock solenoid (A) is OFF (not energized) and the solenoid rod (B) is extended with spring.

The connecting lock lever (C) is located at the position shown in the figure when the solenoid rod is extended. It prevents the movement of the detent rod (D). The selector lever cannot be shifted from the P position for this reason.

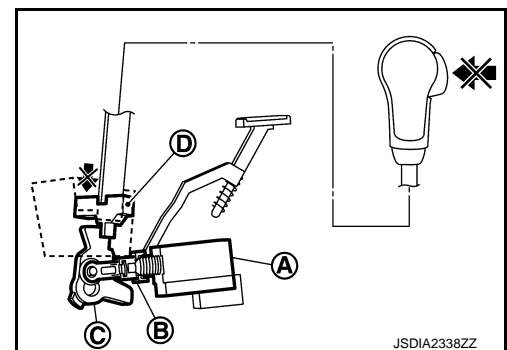

When brake pedal is depressed (selector lever operation allowed)

# SYSTEM

## < SYSTEM DESCRIPTION >

[CVT: RE0F10B]

The shift lock solenoid (A) is turned ON (energized) when the brake pedal is depressed with the ignition switch ON. The solenoid rod (B) is compressed with the electromagnetic force. The connecting lock lever (C) rotates when the solenoid rod is compressed. Therefore, the detent rod (D) can be moved. The selector lever can be shifted to other positions for this reason.

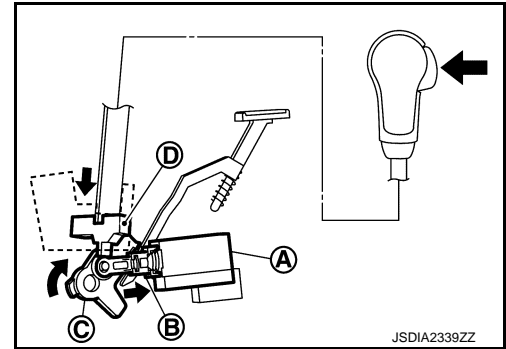

### P POSITION HOLD MECHANISM (IGNITION SWITCH LOCK)

The shift lock solenoid (A) is not energized when the ignition switch is in any position other than ON. The shift mechanism is locked and P position is held. The operation cannot be performed from P position if the brake pedal is depressed with the ignition switch ON when the operation system of shift lock solenoid is malfunctioning. However, the lock lever (B) is forcibly rotated and the shift lock is released when the shift lock release button (C) is pressed from above. The selector operation from P position can be performed.

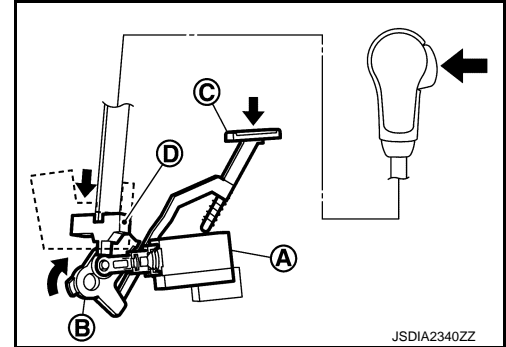

D : Detent rod

### CAUTION:

Use the shift lock release button only when the selector lever cannot be operated even if the brake pedal is depressed with the ignition switch ON.

## KEY LOCK SYSTEM

### KEY LOCK SYSTEM : System Description

INFOID:000000009752541

### KEY LOCK MECHANISM

The key is not set to LOCK when the selector lever is not selected to P position. This prevents the key from being removed from the key cylinder.

#### Key lock status

The slider (B) in the key cylinder (A) is moved to the left side of the figure when the selector lever is in any position other than P position. The rotator (D) that rotates together with the key (C) cannot be rotated for this reason. The key cannot be removed from the key cylinder because it cannot be turned to LOCK (E).

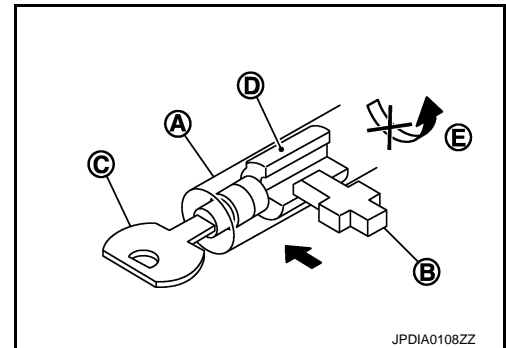

#### Key unlock status

The slider (B) in the key cylinder (A) is moved to the right side of the figure when the selector lever is in P position and the finger is removed from the selector button. The rotator (C) can be rotated for this reason. The key (D) can be removed from the key cylinder because it can be turned to LOCK (E).

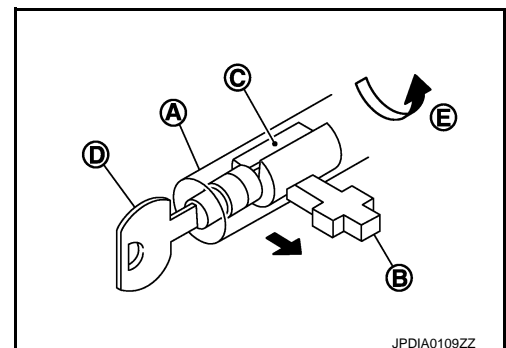

## ON BOARD DIAGNOSTIC (OBD) SYSTEM

### Diagnosis Description

INFOID:000000009752542

#### DESCRIPTION

The CVT system has two self-diagnostic systems.

The first is the emission-related on board diagnostic system (OBD-II) performed by the TCM in combination with the ECM. The malfunction is indicated by the MIL (malfunction indicator lamp) and is stored as a DTC in the ECM memory, and the TCM memory.

The second is the TCM original self-diagnosis performed by the TCM. The malfunction is stored in the TCM memory. The detected items are overlapped with OBD-II self-diagnostic items. For detail, refer to [TM-185](#), "[CONSULT Function](#)".

#### OBD-II FUNCTION

The ECM provides emission-related on board diagnostic (OBD-II) functions for the CVT system. One function is to receive a signal from the TCM used with OBD-related parts of the CVT system. The signal is sent to the ECM when a malfunction occurs in the corresponding OBD-related part. The other function is to indicate a diagnostic result by means of the MIL (malfunction indicator lamp) on the instrument panel. Sensors, switches and solenoid valves are used as sensing elements.

The MIL automatically illuminates in "One or Two Trip Detection Logic" when a malfunction is sensed in relation to CVT system parts.

#### ONE OR TWO TRIP DETECTION LOGIC OF OBD-II

##### One Trip Detection Logic

If a malfunction is sensed during the first test drive, the MIL will illuminate and the malfunction will be stored in the ECM memory as a DTC. The TCM is not provided with such a memory function.

##### Two Trip Detection Logic

When a malfunction is sensed during the first test drive, it is stored in the ECM memory as a 1st trip DTC (diagnostic trouble code) or 1st trip freeze frame data. At this point, the MIL will not illuminate. — 1st trip

If the same malfunction as that experienced during the first test drive is sensed during the second test drive, the MIL will illuminate. — 2nd trip

The "trip" in the "One or Two Trip Detection Logic" means a driving mode in which self-diagnosis is performed during vehicle operation.

#### OBD-II DIAGNOSTIC TROUBLE CODE (DTC)

##### How to Read DTC and 1st Trip DTC

DTC and 1st trip DTC can be read by the following methods.

**(CONSULT with CONSULT or GST) CONSULT or GST (Generic Scan Tool)** Examples: P0705, P0720 etc.

These DTC are prescribed by SAE J2012.

(CONSULT also displays the malfunctioning component or system.)

- **1st trip DTC No. is the same as DTC No.**
- **Output of the diagnostic trouble code indicates that the indicated circuit has a malfunction. However, in case of the Mode II and GST, they do not indicate whether the malfunction is still occurring or occurred in the past and returned to normal.**

**CONSULT can identify them as shown below, therefore, CONSULT (if available) is recommended.**

- DTC or 1st trip DTC of a malfunction is displayed in SELF-DIAGNOSTIC RESULTS mode for "ENGINE" with CONSULT. Time data indicates how many times the vehicle was driven after the last detection of a DTC.
- If the DTC is being detected currently, the time data will be "0".
- If a 1st trip DTC is stored in the ECM, the time data will be "1t".

##### Freeze Frame Data and 1st Trip Freeze Frame Data

- The ECM has a memory function, which stores the driving condition such as fuel system status, calculated load value, engine coolant temperature, short term fuel trim, long term fuel trim, engine speed and vehicle speed at the moment the ECM detects a malfunction.

Data which are stored in the ECM memory, along with the 1st trip DTC, are called 1st trip freeze frame data, and the data, stored together with the DTC data, are called freeze frame data and displayed on CONSULT or GST. The 1st trip freeze frame data can only be displayed on the CONSULT screen, not on the GST. For details, refer to [EC-71](#), "[CONSULT Function](#)".

Only one set of freeze frame data (either 1st trip freeze frame data or freeze frame data) can be stored in the ECM. 1st trip freeze frame data is stored in the ECM memory along with the 1st trip DTC. There is no priority

A  
B  
C  
TM

E  
F  
G  
H  
I  
J  
K  
L  
M  
N  
O

P

# ON BOARD DIAGNOSTIC (OBD) SYSTEM

[CVT: RE0F10B]

## < SYSTEM DESCRIPTION >

for 1st trip freeze frame data, and it is updated each time a different 1st trip DTC is detected. However, once freeze frame data (2nd trip detection/MIL on) is stored in the ECM memory, 1st trip freeze frame data is no longer stored. Remember, only one set of freeze frame data can be stored in the ECM. The ECM has the following priorities to update the data.

Priority	Items	
1	Freeze frame data	Misfire — DTC: P0300 - P0304 Fuel Injection System Function — DTC: P0171, P0172
2		Except the above items (Includes CVT related items)
3	1st trip freeze frame data	

Both 1st trip freeze frame data and freeze frame data (along with the DTC) are cleared when the ECM memory is erased.

### How to Erase DTC

- The diagnostic trouble code can be erased by CONSULT, GST or ECM DIAGNOSTIC TEST MODE as described following.
- **If the battery cable is disconnected, the diagnostic trouble code will be lost within 24 hours.**
- **When you erase the DTC, using CONSULT or GST is easier and quicker than switching the mode selector on the ECM.**
- The following emission-related diagnostic information is cleared from the ECM memory when erasing DTC related to OBD-II. For details, refer to [EC-101, "DTC Index"](#).
- **Diagnostic trouble codes (DTC)**
- **1st trip diagnostic trouble codes (1st trip DTC)**
- **Freeze frame data**
- **1st trip freeze frame data**
- **System readiness test (SRT) codes**
- **Test values**

### How to Erase DTC (With CONSULT)

The emission related diagnostic information in the TCM and ECM can be erased by selecting "ALL Erase" in the "Description" of "FINAL CHECK" mode with CONSULT.

### How to Erase DTC (With GST)

1. If the ignition switch stays ON after repair work, be sure to turn ignition switch OFF once. Wait at least 10 seconds and then turn it ON (engine stopped) again.
2. Select Mode 4 with GST (Generic Scan Tool).

## MALFUNCTION INDICATOR LAMP (MIL)

### Description

The MIL is located on the instrument panel.

1. The MIL will light up when the ignition switch is turned ON without the engine running. This is a bulb check.
  - If the MIL does not light up, refer to [EC-546, "Component Function Check"](#).
2. When the engine is started, the MIL should go off. If the MIL remains on, the on board diagnostic system has detected an engine system malfunction.

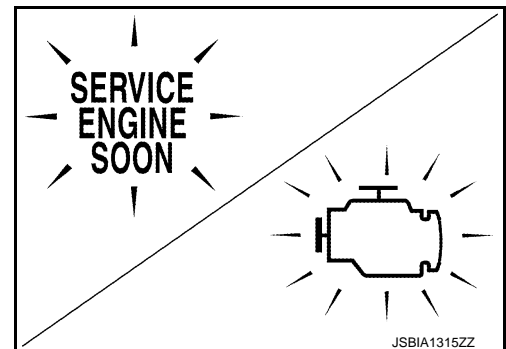



# DIAGNOSIS SYSTEM (TCM)

< SYSTEM DESCRIPTION >

[CVT: RE0F10B]

## DIAGNOSIS SYSTEM (TCM)

### CONSULT Function

INFOID:000000009752543

### APPLICATION ITEMS

Conditions	Function
All DTC Reading	Display all DTCs or diagnostic items that all ECUs are recording and judging.
Work Support	This mode enables a technician to adjust some devices faster and more accurately.
Self Diagnostic Results	Retrieve DTC from ECU and display diagnostic items.
Data Monitor	Monitor the input/output signal of the control unit in real time.
CAN Diagnosis	This mode displays a network diagnosis result about CAN by a diagram.
CAN Diagnosis Support Monitor	It monitors the status of CAN communication.
ECU Identification	Display the ECU identification number (part number etc.) of the selected system.
CALIB DATA	The calibration data status of TCM can be checked.

### SELF DIAGNOSTIC RESULTS

Refer to [TM-198, "DTC Index"](#).

### DATA MONITOR

#### NOTE:

The following table includes information (items) inapplicable to this vehicle. For information (items) applicable to this vehicle, refer to CONSULT display items.

X: Application ▼: Optional selection

Monitored item (Unit)	(Unit)	Monitor item selection		Remarks
		MAIN SIGNALS	ECU INPUT SIGNALS	
VSP SENSOR	(km/h or mph)	▼	X	Displays the vehicle speed calculated from the CVT output shaft speed.
ESTM VSP SIG	(km/h or mph)	▼	X	Displays the vehicle speed signal (ABS) received through CAN communication.
PRI SPEED SEN	(rpm)	▼	X	Displays the primary pulley speed calculated from the pulse signal of the primary speed sensor.
ENG SPEED SIG	(rpm)	▼	X	Displays the engine speed received through CAN communication.
SEC HYDR SEN	(V)	▼	X	Displays the signal voltage of the secondary pressure sensor.
PRI HYDR SEN	(V)	▼	X	<ul style="list-style-type: none"> <li>Displays the signal voltage of the primary pressure sensor.</li> <li>It is displayed although not equipped.</li> </ul>
ATF TEMP SEN	(V)	▼	X	Displays the signal voltage of the CVT fluid temperature sensor.
VIGN SEN	(V)	▼	X	Displays the battery voltage applied to TCM.
VEHICLE SPEED	(km/h or mph)	X	▼	Vehicle speed recognized by the TCM.
PRI SPEED	(rpm)	X	▼	Displays the primary pulley speed recognized by TCM.
SEC SPEED	(rpm)	▼	▼	Displays the secondary pulley speed recognized by TCM.
ENG SPEED	(rpm)	X	▼	Displays the engine speed recognized by TCM.
SLIP REV	(rpm)	X	▼	Displays the speed difference between the input shaft speed of CVT and the engine speed.

# DIAGNOSIS SYSTEM (TCM)

< SYSTEM DESCRIPTION >

[CVT: RE0F10B]

Monitored item (Unit)	(Unit)	Monitor item selection		Remarks
		MAIN SIGNALS	ECU INPUT SIGNALS	
GEAR RATIO		X	▼	Displays the pulley gear ratio calculated from primary pulley speed/secondary pulley speed.
G SPEED	(G)	▼	▼	Displays the acceleration and deceleration speed of the vehicle calculated from vehicle speed change.
ACC PEDAL OPEN	(0.0/8)	X	X	Displays the estimated throttle position received through CAN communication.
SEC PRESS	(MPa)	X	▼	Displays the secondary pressure calculated from the signal voltage of the secondary pressure sensor.
PRI PRESS	(MPa)	X	▼	<ul style="list-style-type: none"> <li>• Displays the primary pressure calculated from the signal voltage of the primary pressure sensor.</li> <li>• It is displayed although not equipped.</li> </ul>
ATFTEMP COUNT		X	▼	Means CVT fluid temperature. Actual oil temperature (° numeric value is converted. Refer to <a href="#">TM-189</a>
DSR REV	(rpm)	▼	▼	Displays the target primary pulley speed calculated from processing of gear shift control.
DGEAR RATIO		▼	▼	Displays the target gear ratio.
DSTM STEP	(step)	▼	▼	Displays the target number of steps of the step motor, calculated from processing of gear shift control.
STM STEP	(step)	X	▼	Displays the actual number of steps of the step motor, calculated from processing of gear shift control.
LU PRS	(MPa)	▼	▼	Displays the target oil pressure of the torque converter clutch solenoid valve calculated from oil pressure processing of gear shift control.
LINE PRS	(MPa)	▼	▼	Displays the target oil pressure of the line pressure solenoid valve calculated from oil pressure processing of gear shift control.
TGT SEC PRESS	(MPa)	▼	▼	Displays the target oil pressure of the secondary pressure solenoid valve calculated from oil pressure processing of gear shift control.
ISOLT1	(A)	X	▼	Displays the command current from TCM to the torque converter clutch solenoid valve.
ISOLT2	(A)	X	▼	Displays the command current from TCM to the line pressure solenoid valve.
ISOLT3	(A)	X	▼	Display the command current from TCM to the secondary pressure solenoid valve.
SOLMON1	(A)	X	X	Monitors the command current from TCM to the torque converter clutch solenoid valve and displays the monitored value.
SOLMON2	(A)	X	X	Monitors the command current from TCM to the line pressure solenoid valve and displays the monitored value.
SOLMON3	(A)	X	X	Monitors the command current from TCM to the secondary pressure solenoid valve and displays the monitored value.
BRAKE SW	(On/Off)	X	X	Displays the reception status of the stop lamp switch signal received through CAN communication.
FULL SW	(On/Off)	X	X	<ul style="list-style-type: none"> <li>• Displays the reception status of the wide open throttle position signal received through CAN communication.</li> <li>• It is displayed although not equipped.</li> </ul>
IDLE SW	(On/Off)	X	X	Displays the reception status of the closed throttle position signal received through CAN communication.

# DIAGNOSIS SYSTEM (TCM)

< SYSTEM DESCRIPTION >

[CVT: RE0F10B]

Monitored item (Unit)	(Unit)	Monitor item selection		Remarks
		MAIN SIGNALS	ECU INPUT SIGNALS	
SPORT MODE SW	(On/Off)	X	X	<ul style="list-style-type: none"> <li>Displays the reception status of the sport mode switch signal received through CAN communication.</li> <li>It is displayed although not equipped.</li> </ul>
STRDWNSW	(On/Off)	▼	X	<ul style="list-style-type: none"> <li>Displays the operation status of the paddle shifter (down switch).</li> <li>NISMO RS models.</li> </ul>
STRUPSW	(On/Off)	▼	X	<ul style="list-style-type: none"> <li>Displays the operation status of the paddle shifter (up switch).</li> <li>NISMO RS models.</li> </ul>
DOWNLVR	(On/Off)	▼	X	Displays the operation status of the selector lever (down switch).
UPLVR	(On/Off)	▼	X	Displays the operation status of the selector lever (up switch).
NONMMODE	(On/Off)	▼	X	Displays if the selector lever position is not at the manual shift gate.
MMODE	(On/Off)	▼	X	Displays if the selector lever position is at the manual shift gate.
INDLRNG	(On/Off)	▼	▼	<ul style="list-style-type: none"> <li>Displays the transmission status of the shift position (L position) signal transmitted through CAN communication.</li> <li>It is displayed although not equipped.</li> </ul>
INDDRNG	(On/Off)	▼	▼	Displays the transmission status of the shift position (D position) signal transmitted through CAN communication.
INDNRNG	(On/Off)	▼	▼	Displays the transmission status of the shift position (N position) signal transmitted through CAN communication.
INDRRNG	(On/Off)	▼	▼	Displays the transmission status of the shift position (R position) signal transmitted through CAN communication.
INDPRNG	(On/Off)	▼	▼	Displays the transmission status of the shift position (P position) signal transmitted through CAN communication.
CVT LAMP	(On/Off)	▼	▼	Displays the transmission status of the CVT indicator signal transmitted through CAN communication.
SPORT MODE IND	(On/Off)	▼	▼	<ul style="list-style-type: none"> <li>Displays the transmission status of the S mode indicator signal transmitted through CAN communication.</li> <li>It is displayed although not equipped.</li> </ul>
MMODE IND	(On/Off)	▼	▼	Displays the transmission status of the manual mode signal transmitted through CAN communication.
SMCOIL D	(On/Off)	▼	▼	Displays the energizing status of step motor coil "D".
SMCOIL C	(On/Off)	▼	▼	Displays the energizing status of step motor coil "C".
SMCOIL B	(On/Off)	▼	▼	Displays the energizing status of step motor coil "B".
SMCOIL A	(On/Off)	▼	▼	Displays the energizing status of step motor coil "A".
LUSEL SOL OUT	(On/Off)	▼	▼	Displays the command value from TCM to the lock-up select solenoid valve.
LUSEL SOL MON	(On/Off)	▼	▼	Monitors the command value from TCM to the lock-up select solenoid valve and displays the monitored value.
VDC ON	(On/Off)	▼	X	Displays the reception status of the VDC operation signal received through CAN communication.

A  
B  
C  
TM  
E  
F  
G  
H  
I  
J  
K  
L  
M  
N  
O  
P

# DIAGNOSIS SYSTEM (TCM)

< SYSTEM DESCRIPTION >

[CVT: RE0F10B]

Monitored item (Unit)	(Unit)	Monitor item selection		Remarks
		MAIN SIGNALS	ECU INPUT SIGNALS	
TCS ON	(On/Off)	▼	X	Displays the reception status of the TCS operation signal received through CAN communication.
ABS ON	(On/Off)	▼	X	Displays the reception status of the ABS operation signal received through CAN communication.
ACC ON	(On/Off)	▼	X	It is displayed although not equipped.
RANGE		X	▼	Displays the gear position recognized by TCM.
M GEAR POS		X	▼	Display the target gear of manual mode
D POSITION SW	(On/Off)	▼	X	Displays the operation status of the transmission range switch (D position).
N POSITION SW	(On/Off)	▼	X	Displays the operation status of the transmission range switch (N position).
L POSITION SW	(On/Off)	▼	X	Displays the operation status of the transmission range switch (L position).
P POSITION SW	(On/Off)	▼	X	Displays the operation status of the transmission range switch (P position).
R POSITION SW	(On/Off)	▼	X	Displays the operation status of the transmission range switch (R position).
DRIVE MODE STATS	(On/Off)	▼	▼	<ul style="list-style-type: none"> <li>• Displays the drive mode status recognized by TCM.</li> <li>• Only vehicle with Integrated Control System are displayed.</li> </ul>
SNOW MODE	(On/Off)	▼	▼	<ul style="list-style-type: none"> <li>• Display the drive mode (SNOW switch status) of Integrated Control System received through CAN communication.</li> <li>• Only vehicle with Integrated Control System are displayed.</li> <li>• It is displayed although not equipped.</li> </ul>
ECO MODE	(On/Off)	▼	▼	<ul style="list-style-type: none"> <li>• Display the driving mode (ECO switch status) of Integrated Control System received through CAN communication.</li> <li>• Only vehicle with Integrated Control System are displayed.</li> </ul>
NORMAL MODE	(On/Off)	▼	▼	<ul style="list-style-type: none"> <li>• Display the driving mode (AUTO switch status) of Integrated Control System received through CAN communication.</li> <li>• Only vehicle with Integrated Control System are displayed.</li> </ul>
SPORT MODE	(On/Off)	▼	▼	<ul style="list-style-type: none"> <li>• Display the driving mode (SPORT switch status) of Integrated Control System received through CAN communication.</li> <li>• Only vehicle with Integrated Control System are displayed.</li> </ul>
CVT-A	(On/Off)	—	—	This monitor item does not use.
CVT-B	(On/Off)	—	—	This monitor item does not use.

## WORK SUPPORT

Item name	Description
ENGINE BRAKE ADJ.	The engine brake level setting can be canceled.
CONFORM CVTF DETERIORTN	The CVT fluid deterioration level can be checked.

Engine Brake Adjustment

# DIAGNOSIS SYSTEM (TCM)

< SYSTEM DESCRIPTION >

[CVT: RE0F10B]

## “ENGINE BRAKE LEVEL”

**0:** Initial set value (Engine brake level control is activated)

**OFF:** Engine brake level control is deactivated.

### CAUTION:

Mode of “+1” “0” “-1” “-2” “OFF” can be selected by pressing the “UP” “DOWN” on CONSULT screen. However, do not select mode other than “0” and “OFF”. If the “+1” or “-1” or “-2” is selected, that might cause the irregular driveability.

Check CVT Fluid Deterioration Date

## “CVTF DETERIORATION DATE”

**210000 or more:**

It is necessary to change CVT fluid.

**Less than 210000:**

It is not necessary to change CVT fluid.

### CAUTION:

Touch “CLEAR” after changing CVT fluid, and then erase “CVTF DETERIORATION DATE”.

## ATFTEMP COUNT Conversion Table

INFOID:000000009752544

ATFTEMP COUNT	Temperature °C (°F)	ATFTEMP COUNT	Temperature °C (°F)
4	-30 (-22)	177	90 (194)
8	-20 (-4)	183	95 (203)
13	-10 (14)	190	100 (212)
17	-5 (23)	196	105 (221)
21	0 (32)	201	110 (230)
27	5 (41)	206	115 (239)
32	10 (50)	210	120 (248)
39	15 (59)	214	125 (257)
47	20 (68)	218	130 (266)
55	25 (77)	221	135 (275)
64	30 (86)	224	140 (284)
73	35 (95)	227	145 (293)
83	40 (104)	229	150 (302)
93	45 (113)	231	155 (311)
104	50 (122)	233	160 (320)
114	55 (131)	235	165 (329)
124	60 (140)	236	170 (338)
134	65 (149)	238	175 (347)
143	70 (158)	239	180 (356)
152	75 (167)	241	190 (374)
161	80 (176)	243	200 (392)
169	85 (185)	—	—

## Diagnostic Tool Function

INFOID:000000009752545

 OBD-II SELF-DIAGNOSTIC PROCEDURE (WITH GST)

Refer to [EC-60, "GST \(Generic Scan Tool\)"](#).

# ECU DIAGNOSIS INFORMATION

## TCM

### Reference Value

INFOID:000000009752546

### VALUES ON THE DIAGNOSIS TOOL

#### NOTE:

The following table includes information (items) inapplicable to this vehicle. For information (items) applicable to this vehicle, refer to CONSULT display items.

Item name	Condition	Display value (Approx.)
VSP SENSOR	During driving	Approximately matches the speedometer reading.
ESTM VSP SIG	During driving	Approximately matches the speedometer reading.
PRI SPEED SEN	During driving (lock-up ON)	Approximately matches the engine speed.
ENG SPEED SIG	Engine running	Closely matches the tachometer reading.
SEC HYDR SEN	<ul style="list-style-type: none"> <li>• Selector lever: "N" position</li> <li>• At idle</li> </ul>	Approx. 0.8 V
ATF TEMP SEN	CVT fluid: Approx. 20°C (68°F)	Approx. 2.01 – 2.05 V
	CVT fluid: Approx. 50°C (122°F)	Approx. 1.45 – 1.50 V
	CVT fluid: Approx. 80°C (176°F)	Approx. 0.90 – 0.94 V
VIGN SEN	Ignition switch: ON	10 – 16 V
VEHICLE SPEED	During driving	Approximately matches the speedometer reading.
PRI SPEED	During driving (lock-up ON)	Approximately matches the engine speed.
SEC SPEED	During driving	48 X Approximately matches the speedometer reading.
ENG SPEED	Engine running	Closely matches the tachometer reading.
SLIP REV	During driving	engine speed – primary speed
GEAR RATIO	During driving	2.349 – 0.394
G SPEED	Vehicle stopped	Approx. 0.00 G
	During acceleration	The value changes to the positive side along with acceleration.
	During deceleration	The value changes to the positive side along with deceleration.
ACC PEDAL OPEN	Released accelerator pedal - Fully depressed accelerator pedal	0.0/8 – 8.0/8
SEC PRESS	<ul style="list-style-type: none"> <li>• After engine warm up</li> <li>• Selector lever: "N" position</li> <li>• At idle</li> </ul>	Approx. 1.6 MPa
ATFTEMP COUNT*1	CVT fluid: Approx. 20°C (68°F)	47
	CVT fluid: Approx. 50°C (122°F)	104
	CVT fluid: Approx. 80°C (176°F)	161
DSR REV	During driving	The value changes to the positive side along with deceleration.
DGEAR RATIO	During driving	The value changes to the positive side along with deceleration.
DSTM STEP	During driving	0 step – 182 step
STM STEP	During driving	0 step – 182 step

# TCM

< ECU DIAGNOSIS INFORMATION >

[CVT: RE0F10B]

Item name	Condition	Display value (Approx.)	
LU PRS	<ul style="list-style-type: none"> <li>• Engine started</li> <li>• Vehicle is stopped.</li> </ul>	Approx. -0.400 MPa	A
	<ul style="list-style-type: none"> <li>• Selector lever: "D" position</li> <li>• Accelerator pedal position: 1/8 or less</li> <li>• Vehicle speed: 20 km/h (12 MPH) or more</li> </ul>	Approx. 0.400 MPa	B
LINE PRS	<ul style="list-style-type: none"> <li>• After engine warm up</li> <li>• Selector lever: "N" position</li> <li>• At idle</li> </ul>	Approx. 0.750 MPa	C
	<ul style="list-style-type: none"> <li>• After engine warm up</li> <li>• Selector lever: "N" position</li> <li>• Depress the accelerator pedal fully</li> </ul>	Approx. 4.930 – 5.430 MPa	TM
TGT SEC PRESS	<ul style="list-style-type: none"> <li>• After engine warm up</li> <li>• Selector lever: "N" position</li> <li>• At idle</li> </ul>	Approx. 0.700 MPa	E
ISOLT1	Lock-up "OFF"	Approx. 0.0 A	
	Lock-up "ON"	Approx. 0.7 A	F
ISOLT2	Release your foot from the accelerator pedal	Approx. 0.8 A	
	Press the accelerator pedal all the way down	Approx. 0.0 A	
ISOLT3	Secondary pressure low - Secondary pressure high	Approx. 0.8 – 0.0 A	G
SOLMON1	Lock-up "OFF"	Approx. 0.0 A	
	Lock-up "ON"	Approx. 0.7 A	H
SOLMON2	<ul style="list-style-type: none"> <li>• Selector lever: "N" position</li> <li>• At idle</li> </ul>	Approx. 0.8 A	
	When stalled	Approx. 0.3 – 0.6 A	I
SOLMON3	<ul style="list-style-type: none"> <li>• Selector lever: "N" position</li> <li>• At idle</li> </ul>	Approx. 0.6 – 0.7 A	
	When stalled	Approx. 0.4 – 0.6 A	J
BRAKE SW	Depressed brake pedal	On	
	Released brake pedal	Off	
FULL SW	Always	Off	K
IDLE SW	Released accelerator pedal	On	
	Fully depressed accelerator pedal	Off	L
SPORT MODE SW	Always	Off	
STRDWNSW*3	Paddle shifter (Down) is pulled	On	
	Other than the above	Off	M
STRUPSW*3	Paddle shifter (Up) is pulled	On	
	Other than the above	Off	N
DOWNLVR	Selector lever: - side	On	
	Other than the above	Off	
UPLVR	Selector lever: + side	On	O
	Other than the above	Off	
NONMMODE	Manual shift gate position (neutral, +side, -side)	Off	
	Other than the above	On	P
MMODE	Manual shift gate position (neutral)	On	
	Other than the above	Off	
INDLRNG	Always	Off	
INDDRNG	Selector lever in "D" position	On	
	When setting selector lever to other positions	Off	

# TCM

< ECU DIAGNOSIS INFORMATION >

[CVT: RE0F10B]

Item name	Condition	Display value (Approx.)
INDNRNG	Selector lever in "N" position	On
	When setting selector lever to other positions	Off
INDRRNG	Selector lever in "R" position	On
	When setting selector lever to other positions	Off
INDPRNG	Selector lever in "P" position	On
	When setting selector lever to other positions	Off
CVT LAMP	Approx. 2 seconds after ignition switch ON	On
	Other conditions	Off
SPORT MODE IND	Always	Off
MMODE IND	In manual mode	On
	Other conditions	Off
SMCOIL D	During driving	Changes On ⇔ Off
SMCOIL C	During driving	Changes On ⇔ Off
SMCOIL B	During driving	Changes On ⇔ Off
SMCOIL A	During driving	Changes On ⇔ Off
LUSEL SOL OUT	Selector lever: "P", "N" positions	On
	Wait at least for 5 seconds with the selector lever in "R", "D" positions	Off
LUSEL SOL MON	Selector lever: "P", "N" positions	On
	Wait at least for 5 seconds with the selector lever in "R", "D" positions	Off
VDC ON	ESP is activated	On
	Other conditions	Off
TCS ON	TCS is activated	On
	Other conditions	Off
ABS ON	ABS is activated	On
	Other conditions	Off
ACC ON	Always	Off
RANGE	Selector lever in "N" or "P" position	N·P
	Selector lever in "R" position	R
	Selector lever in "D" position	D
M GEAR POS	Gear position: M1	1
	Gear position: M2	2
	Gear position: M3	3
	Gear position: M4	4
	Gear position: M5	5
	Gear position: M6	6
	Gear position: M7	7
	Gear position: M8	8
D POSITION SW	Selector lever in "D" position	On
	Other than the above position	Off
N POSITION SW	Selector lever in "N" position	On
	Other than the above position	Off
L POSITION SW	Always	Off



# TCM

< ECU DIAGNOSIS INFORMATION >

[CVT: RE0F10B]

Item name	Condition	Display value (Approx.)
P POSITION SW	Selector lever in "P" position	On
	Other than the above position	Off
R POSITION SW	Selector lever in "R" position	On
	Other than the above position	Off
DRIVE MODE STATS*2	Integrated Control System: NORMAL mode	NORMAL
	Integrated Control System: ECO mode	ECO
	Integrated Control System: SPORT mode	SPORT
SPORT MODE*2	Integrated Control System: SPORT mode	On
	Other conditions	Off
NORMAL MODE*2	Integrated Control System: NORMAL mode	On
	Other conditions	Off
ECO MODE*2	Integrated Control System: ECO mode	On
	Other conditions	Off
SNOW MODE*2	Always	Off
CVT-A	—	—
CVT-B	—	—

\*1: Means CVT fluid temperature. Convert numerical values for actual fluid temperature °C (°F). Refer to [TM-189. "ATFTEMP COUNT Conversion Table"](#).

\*2: With Integrated Control System

\*3: NISMO RS models

## TERMINAL LAYOUT

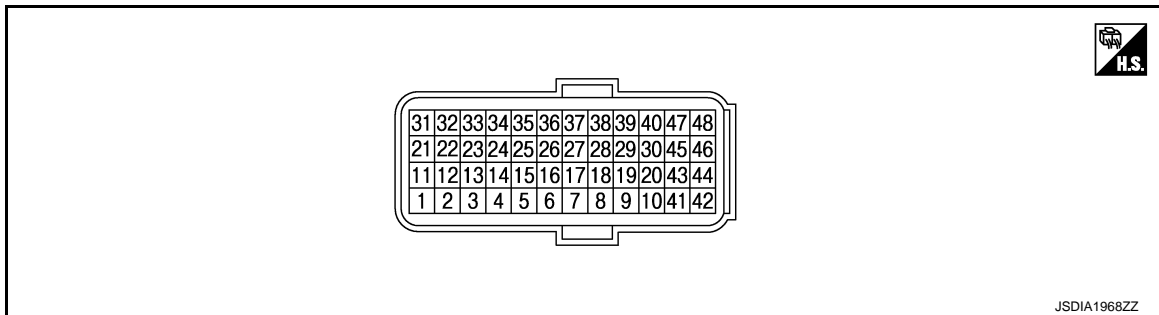

## PHYSICAL VALUES

Terminal No. (wire color)		Description		Condition	Value (Approx.)
+	-	Signal name	Input/Output		
1 (G)	Ground	R RANGE SW	Input	Selector lever in "R" position	10 – 16 V
				Other than the above position	0 V
2 (Y)	Ground	N RANGE SW	Input	Ignition switch ON Selector lever in "N" position	10 – 16 V
				Other than the above position	0 V
3 (W)	Ground	D RANGE SW	Input	Selector lever in "D" positions	10 – 16 V
				Other than the above position	0 V

# TCM

< ECU DIAGNOSIS INFORMATION >

[CVT: RE0F10B]

Terminal No. (wire color)		Description		Condition		Value (Approx.)
+	-	Signal name	Input/Output			
4*1 (V)	—	—	—	—		—
5 (B)	Ground	Ground	Output	Always		0 V
8 (BR)	—	CLOCK (SEL2)	—	—		—
9 (G)	—	CHIP SELECT (SEL1)	—	—		—
10 (W)	—	DATA I/O (SEL3)	—	—		—
11 (L)	Ground	P RANGE SW	Input	Ignition switch ON	Selector lever in "P" position	10 – 16 V
					Other than the above position	0 V
13 (SB)	Ground	CVT fluid temper- ature sensor	Input	Ignition switch ON	When CVT fluid tem- perature is 20°C (68°F)	2.0 V
					When CVT fluid tem- perature is 80°C (176°F)	1.0 V
15 (P)	Ground	Secondary pres- sure sensor	Input	<ul style="list-style-type: none"> <li>• Selector lever: "N" position</li> <li>• Idle speed</li> </ul>		1.0 V
25 (Y)	Ground	Sensor ground	Input	Always		0 V
26 (LG)	Ground	Sensor power supply	Output	Ignition switch ON		5.0 V
				Ignition switch OFF		0 V
27 (GR)	Ground	Step motor D	Output	Within 2 seconds after ignition switch ON, the time measurement by using the pulse width measurement func- tion (Hi level) of CONSULT.*2  <b>CAUTION:</b> <b>Connect the diagnosis data link ca- ble to the vehicle diagnosis con- nector.</b>		10.0 msec
28 (V)	Ground	Step motor C	Output			30.0 msec
29 (BG)	Ground	Step motor B	Output			10.0 msec
30 (R)	Ground	Step motor A	Output			30.0 msec
31 (P)	—	CAN-L	Input/Output	—		—
32 (L)	—	CAN-H	Input/Output	—		—
33 (BG)	Ground	Primary speed sensor	Input	<ul style="list-style-type: none"> <li>• Selector lever: "M1" position</li> <li>• While driving at 20 km/h (12 MPH)</li> </ul>		720 Hz

JPDA0819ZZ

# TCM

< ECU DIAGNOSIS INFORMATION >

[CVT: RE0F10B]

Terminal No. (wire color)		Description		Condition		Value (Approx.)
+	-	Signal name	Input/Output			
34 (R)	Ground	Secondary speed sensor	Input	<ul style="list-style-type: none"> <li>Selector lever: "M1" position</li> <li>While driving at 20 km/h (12 MPH)</li> </ul>		480 Hz 
37 (L)	Ground	Lock-up select solenoid valve	Output	Ignition switch ON	Selector lever in "P" or "N" positions	10 – 16 V
					Wait at least for 5 seconds with the selector lever in "R" or "D" positions.	0 V
38 (G)	Ground	Torque converter clutch solenoid valve	Output	When vehicle cruises in "D" position	When CVT performs lock-up	6.0 V
					When CVT does not perform lock-up	1.5 V
39 (W)	Ground	Secondary pressure solenoid valve	Output	"P" or "N" position idle	Release your foot from the accelerator pedal.	5.0 – 7.0 V
					Press the accelerator pedal all the way down.	3.0 – 4.0 V
40 (Y)	Ground	Line pressure solenoid valve	Output		Release your foot from the accelerator pedal.	5.0 – 7.0 V
					Press the accelerator pedal all the way down.	1.0 V
42 (B)	Ground	Ground	Output	Always		0 V
46 (LG)	Ground	Ignition power supply	Input	Ignition switch ON	—	10 – 16 V
				Ignition switch OFF	—	0 V
47 (BG)	Ground	Battery power supply (memory back-up)	Input	Always		10 – 16 V
48 (Y)	Ground	Ignition power supply	Input	Ignition switch ON	—	10 – 16 V
				Ignition switch OFF	—	0 V

\*1: This harness is not used.

\*2: A circuit tester cannot be used to test this item.

## Fail-Safe

INFOID:000000009752547

The TCM has an electrical fail-safe mode. In this mode TCM is operator even if there is an error in a main electronic control input/output signal circuit.

## DESCRIPTION

When a malfunction is detected in each sensor, switch, solenoid or others, this function provides control to minimize reduction of drivability so that durability of transmission assembly can be acquired.

# TCM

< ECU DIAGNOSIS INFORMATION >

[CVT: RE0F10B]

DTC	Condition	Vehicle behavior
P0703	—	<ul style="list-style-type: none"> <li>• Start is slow</li> <li>• Acceleration is slow</li> </ul>
P0705	—	<ul style="list-style-type: none"> <li>• Position indicator on combination meter is not displayed</li> <li>• Selector shock is large</li> <li>• Start is slow</li> <li>• Acceleration at high load state is slow</li> <li>• Manual mode is not activated</li> <li>• Lock-up is not performed</li> </ul>
P0710	Engine coolant temperature when engine starts is 10°C (50°F) or more	Start is slow
	Engine coolant temperature when engine starts is 10°C (50°F) or less	<ul style="list-style-type: none"> <li>• Start is slow</li> <li>• Acceleration is slow</li> <li>• Vehicle speed is not increased</li> </ul>
	Engine coolant temperature when engine starts is -35°C (-31°F) or less	Vehicle speed is not increased
P0715	—	<ul style="list-style-type: none"> <li>• Acceleration is slow</li> <li>• Re-start is slow after vehicle is stop by strong deceleration</li> <li>• Manual mode is not activated</li> <li>• Lock-up is not performed</li> </ul>
P0720	—	<ul style="list-style-type: none"> <li>• Start is slow</li> <li>• Acceleration is slow</li> <li>• Re-start is slow after vehicle is stop by strong deceleration</li> <li>• Manual mode is not activated</li> <li>• Lock-up is not performed</li> </ul>
P0725	—	Lock-up is not performed
P0740	—	<ul style="list-style-type: none"> <li>• Selector shock is large</li> <li>• Lock-up is not performed</li> </ul>
P0744	—	Lock-up is not performed
P0746	A malfunction is detected	<ul style="list-style-type: none"> <li>• Start is slow</li> <li>• Acceleration is slow</li> <li>• Lock-up is not performed</li> </ul>
	Function is excessively reduced after a malfunction is detected	<ul style="list-style-type: none"> <li>• Start is difficult</li> <li>• Drive is difficult</li> <li>• Lock-up is not performed</li> </ul>
P0778	—	Vehicle speed is not increased
P0826	—	Manual mode is not activated
P0840	—	<ul style="list-style-type: none"> <li>• Start is slow</li> <li>• Acceleration is slow</li> </ul>
P0841	—	<ul style="list-style-type: none"> <li>• Start is slow</li> <li>• Acceleration is slow</li> </ul>
P0845	—	<ul style="list-style-type: none"> <li>• Start is slow</li> <li>• Acceleration is slow</li> </ul>
P0868	—	<ul style="list-style-type: none"> <li>• Start is slow</li> <li>• Acceleration is slow</li> </ul>
P1701	—	<ul style="list-style-type: none"> <li>• Start is slow</li> <li>• Acceleration is slow</li> </ul>
P1705	—	<ul style="list-style-type: none"> <li>• Acceleration is slow</li> <li>• Lock-up is not performed</li> </ul>
P1709	—	<ul style="list-style-type: none"> <li>• Start is slow</li> <li>• Acceleration is slow</li> <li>• Shift position indicator (P, N) is not displayed, or is displayed with delay.</li> </ul>

# TCM

< ECU DIAGNOSIS INFORMATION >

[CVT: RE0F10B]

DTC	Condition	Vehicle behavior
P1722	—	Lock-up is not activated in coast state
P1723	A malfunction is detected in primary pulley speed sensor side	<ul style="list-style-type: none"> <li>• Acceleration is slow</li> <li>• Re-start is slow after vehicle is stop by strong deceleration</li> <li>• Manual mode is not activated</li> <li>• Lock-up is not performed</li> </ul>
	A malfunction is detected in secondary pulley speed sensor	<ul style="list-style-type: none"> <li>• Start is slow</li> <li>• Acceleration is slow</li> <li>• Re-start is slow after vehicle is stop by strong deceleration</li> <li>• Manual mode is not activated</li> <li>• Lock-up is not performed</li> </ul>
P1726	—	Acceleration is slow
P1740	—	<ul style="list-style-type: none"> <li>• Selector shock is large</li> <li>• Lock-up is not performed</li> </ul>
P1777	A malfunction is detected in low side (when vehicle is stopped)	<ul style="list-style-type: none"> <li>• Vehicle speed is not increased</li> <li>• Lock-up is not performed</li> </ul>
	A malfunction is detected in high side (during driving)	<ul style="list-style-type: none"> <li>• Start is slow</li> <li>• Acceleration is slow</li> <li>• Lock-up is not performed</li> </ul>
U0100	—	<ul style="list-style-type: none"> <li>• Start is slow</li> <li>• Acceleration is slow</li> <li>• Vehicle speed is not increased</li> </ul>
U1000	—	<ul style="list-style-type: none"> <li>• Start is slow</li> <li>• Acceleration is slow</li> <li>• Vehicle speed is not increased</li> </ul>
U1010	—	<ul style="list-style-type: none"> <li>• Start is slow</li> <li>• Acceleration is slow</li> <li>• Vehicle speed is not increased</li> </ul>

## DTC Inspection Priority Chart

INFOID:000000009752548

If some DTCs are displayed at the same time, perform inspections one by one based on the following priority chart.

Priority	Detected items (DTC)	Reference
1	P1709 INCOMPLETED DATA WRITING	<a href="#">TM-276, "DTC Logic"</a>
	U0100 LOST COMM (ECM A)	<a href="#">TM-227, "DTC Logic"</a>
	U1000 CAN COMM CIRC	<a href="#">TM-228, "DTC Logic"</a>
	U1010 CONTROL UNIT (CAN)	<a href="#">TM-229, "DTC Logic"</a>
2	P0725 ENGINE SPEED	<a href="#">TM-245, "DTC Logic"</a>
	P1705 TP SENSOR	<a href="#">TM-275, "DTC Logic"</a>
	P1726 THROTTLE CONTROL SIG	<a href="#">TM-281, "DTC Logic"</a>

# TCM

< ECU DIAGNOSIS INFORMATION >

[CVT: RE0F10B]

Priority	Detected items (DTC)	Reference
3	P0703 BRAKE SWITCH B	<a href="#">TM-230, "DTC Logic"</a>
	P0705 T/M RANGE SENSOR A	<a href="#">TM-233, "DTC Logic"</a>
	P0710 FLUID TEMP SENSOR A	<a href="#">TM-236, "DTC Logic"</a>
	P0715 INPUT SPEED SENSOR A	<a href="#">TM-239, "DTC Logic"</a>
	P0720 OUTPUT SPEED SENSOR	<a href="#">TM-242, "DTC Logic"</a>
	P0740 TORQUE CONVERTER	<a href="#">TM-246, "DTC Logic"</a>
	P0745 PC SOLENOID A	<a href="#">TM-251, "DTC Logic"</a>
	P0778 PC SOLENOID B	<a href="#">TM-257, "DTC Logic"</a>
	P0826 UP/DOWN SHIFT SWITCH	<a href="#">TM-259, "DTC Logic"</a>
	P0840 FLUID PRESS SEN/SW A	<a href="#">TM-265, "DTC Logic"</a>
	P1701 TCM	<a href="#">TM-272, "DTC Logic"</a>
	P1722 VEHICLE SPEED	<a href="#">TM-278, "DTC Logic"</a>
	P1740 SLCT SOLENOID	<a href="#">TM-282, "DTC Logic"</a>
	P1777 STEP MOTOR	<a href="#">TM-284, "DTC Logic"</a>
4	P0744 TORQUE CONVERTER	<a href="#">TM-249, "DTC Logic"</a>
	P0746 PC SOLENOID A	<a href="#">TM-253, "DTC Logic"</a>
	P0776 PC SOLENOID B	<a href="#">TM-255, "DTC Logic"</a>
	P0841 FLUID PRESS SEN/SW A	<a href="#">TM-268, "DTC Logic"</a>
	P0868 FLUID PRESS LOW	<a href="#">TM-270, "DTC Logic"</a>
	P1723 SPEED SENSOR	<a href="#">TM-279, "DTC Logic"</a>
	P1778 STEP MOTOR	<a href="#">TM-287, "DTC Logic"</a>

## DTC Index

INFOID:000000009752549

**NOTE:**

If multiple malfunction codes are detected at the same time, check each code according to the "DTC check priority list". [TM-197, "DTC Inspection Priority Chart"](#).

DTC		Items (CONSULT screen terms)	Reference
"ENGINE" with CONSULT or GST*	"TRANSMISSION" with CONSULT		
—	P0703	BRAKE SWITCH B	<a href="#">TM-230</a>
P0705	P0705	T/M RANGE SENSOR A	<a href="#">TM-233</a>
P0710	P0710	FLUID TEMP SENSOR A	<a href="#">TM-236</a>
P0715	P0715	INPUT SPEED SENSOR A	<a href="#">TM-239</a>
P0720	P0720	OUTPUT SPEED SENSOR	<a href="#">TM-242</a>
—	P0725	ENGINE SPEED	<a href="#">TM-245</a>
P0740	P0740	TORQUE CONVERTER	<a href="#">TM-246</a>
P0744	P0744	TORQUE CONVERTER	<a href="#">TM-249</a>
P0745	P0745	PC SOLENOID A	<a href="#">TM-251</a>
P0746	P0746	PC SOLENOID A	<a href="#">TM-253</a>
P0776	P0776	PC SOLENOID B	<a href="#">TM-255</a>
P0778	P0778	PC SOLENOID B	<a href="#">TM-257</a>
—	P0826	UP/DOWN SHIFT SWITCH	<a href="#">TM-259</a>
P0840	P0840	FLUID PRESS SEN/SW A	<a href="#">TM-265</a>
—	P0841	FLUID PRESS SEN/SW A	<a href="#">TM-268</a>

# TCM

< ECU DIAGNOSIS INFORMATION >

[CVT: RE0F10B]

DTC		Items (CONSULT screen terms)	Reference
"ENGINE" with CONSULT or GST*	"TRANSMISSION" with CONSULT		
—	P0868	FLUID PRESS LOW	<a href="#">TM-270</a>
—	P1701	TCM	<a href="#">TM-272</a>
—	P1705	TP SENSOR	<a href="#">TM-275</a>
—	P1709	INCOMPLETED DATA WRITING	<a href="#">TM-276</a>
—	P1722	VEHICLE SPEED	<a href="#">TM-278</a>
—	P1723	SPEED SENSOR	<a href="#">TM-279</a>
—	P1726	THROTTLE CONTROL SIG	<a href="#">TM-281</a>
P1740	P1740	SLCT SOLENOID	<a href="#">TM-282</a>
P1777	P1777	STEP MOTOR	<a href="#">TM-284</a>
P1778	P1778	STEP MOTOR	<a href="#">TM-287</a>
U0100	U0100	LOST COMM (ECM A)	<a href="#">TM-227</a>
U1000	U1000	CAN COMM CIRCUIT	<a href="#">TM-228</a>
—	U1010	CONTROL UNIT (CAN)	<a href="#">TM-229</a>

\*: These numbers are prescribed by SAE J2012.

A  
B  
C  
TM  
E  
F  
G  
H  
I  
J  
K  
L  
M  
N  
O  
P

< WIRING DIAGRAM >

# WIRING DIAGRAM

## CVT CONTROL SYSTEM

### Wiring Diagram

INFOID:000000009752550

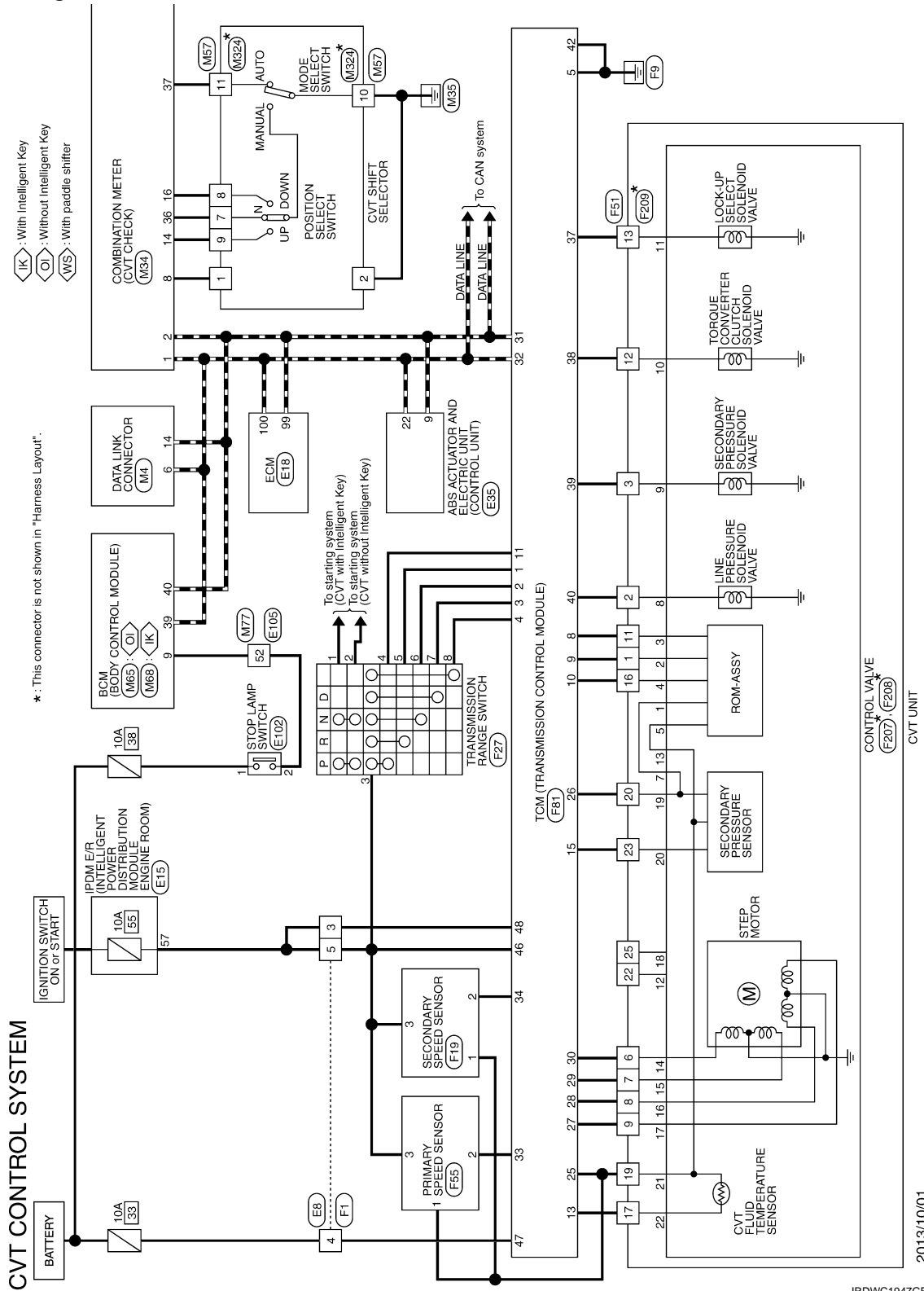

2013/10/01

JRDWC1947GB



# CVT CONTROL SYSTEM

< WIRING DIAGRAM >

[CVT: RE0F10B]

A  
B  
C  
TM  
E  
F  
G  
H  
I  
J  
K  
L  
M  
N  
O  
P

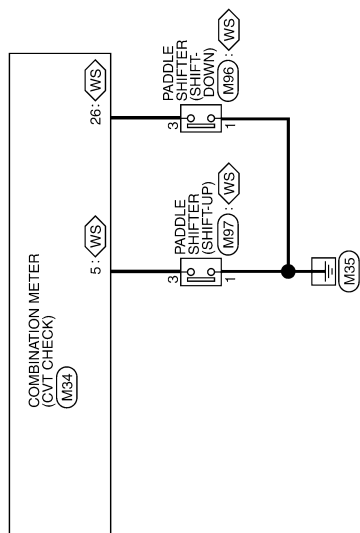

JRDWC1948GB

# CVT CONTROL SYSTEM

< WIRING DIAGRAM >

[CVT: RE0F10B]

## CVT CONTROL SYSTEM

Connector No.	E8
Connector Name	WIRE TO WIRE
Connector Type	SAAS38MB-ES10-S12Z



Terminal No.	Color Of Wire	Signal Name [Specification]
1	P	
2	P	
3	O	
4	LG	
5	O	
6	V	
7	BR	
8	SB	
10	R	
11	O	
12	G	
13	O	
14	R	
15	R	
16	SB	
17	CB	
18	W	
19	L/B	
20	L/W	
21	G	
22	G	
23	SHIELD	
24	P	
25	R	
26	B	
27	B	
28	LG	
29	SB	
30	R	
31	G	
32	Y	
33	BR	
34	W	
37	L	
39	B	

40	P	-
41	Y	-
42	L	-
43	BR	-
44	G	-
45	BR	-
46	Y	-
47	SB	-
48	LG	-

Connector No.	E15
Connector Name	MODULE INTELLIGENT POWER DISTRIBUTION MODULE ENGINE
Connector Type	NS16PW-CS



Terminal No.	Color Of Wire	Signal Name [Specification]
49	Y	
50	G	
51	L	
52	P	
54	P	
55	G	
56	SB	
57	O	
58	LG	
59	V	
60	SB	
61	LG	
62	O	

Connector No.	E16
Connector Name	ECM
Connector Type	RH24FY-R26-F-RH

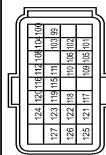

Terminal No.	Color Of Wire	Signal Name [Specification]
100	P	CAN COMMUNICATION LINE (CAN-L)
101	P	CAN COMMUNICATION LINE (CAN-H)
102	V	SENSOR POWER SUPPLY
103	R	ACCELERATOR PEDAL POSITION SENSOR 1
104	R	P/W SIGNAL
105	GR	DATA LINK CONNECTOR
106	Y	SENSOR OPERABLE ACCELERATOR PEDAL POSITION SENSOR 2
108	GR	POWER SUPPLY FOR ECM (BACKUP)
109	O	CLUTCH PEDAL POSITION SWITCH
110	O	IGNITION SWITCH
111	P	ASCD STEERING SWITCH
112	B	SENSOR GROUND
113	BR	ECM RELAY (SELF SHUT-OFF)
114	Y	STOP LAMP SWITCH
115	SB	STOP LAMP SWITCH
116	Y	STOP LAMP SWITCH
117	Y	BRAKE FULL SHUT-OFF SWITCH
118	O	SENSOR POWER SUPPLY
119	BR	ACCELERATOR PEDAL POSITION SENSOR 2
120	Y	SENSOR GROUND
121	G	POWER SUPPLY FOR ECM
122	GR	THROTTLE CONTROL MOTOR POWER SUPPLY
123	B/Y	ECM GROUND
124	B/Y	ECM GROUND
125	L	A/F SENSOR 1 HEATER
126	W	HEATED OXYGEN SENSOR 2 HEATER
127	B/Y	ECM GROUND

Connector No.	E35
Connector Name	ABS ACTIVATOR AND ELECTRIC PART CONTROL UNIT
Connector Type	RH28EE-N14-UH

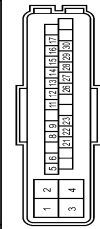

Terminal No.	Color Of Wire	Signal Name [Specification]
1	W	BAT (MFB)
2	W	BAT (SO-L)
3	B	GND (SO-L)
4	B	GND (MFI)
5	GR	VDC OFF SW
6	GR	BRAKE PEDAL POSITION SW
8	SB	STOP LAMP SW
9	P	CAN-L
11	BR	DP RR
12	W	DS FR
13	G	VCC
14	R	SERIAL*
15	Y	DS RR
16	V	IGN
17	W	REFLECT SIGNAL
21	Y	DP RR
22	L	CAN-H
23	LG	DP FL
26	SB	DP RL
27	BR	DS FL
28	B	GND
29	W	SERIAL-
30	O	DS RL

# CVT CONTROL SYSTEM

< WIRING DIAGRAM >

[CVT: RE0F10B]

## CVT CONTROL SYSTEM

Connector No.	E102
Connector Name	STOP LAMP SWITCH
Connector Type	M04FW-LC



Terminal No.	Color Of Wire	Signal Name [Specification]
1	W	-
2	GR	-
4	LG	-

Connector No.	E105
Connector Name	WIRE TO WIRE
Connector Type	T180MM-C516-1M4

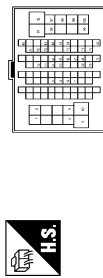

Terminal No.	Color Of Wire	Signal Name [Specification]
1	L	-
4	Y	-
5	GR	-
6	P	-
9	G	-
10	R	-
34	O	-
35	GR	-
38	B	-
52	SB	-
53	BR	-
54	V	-
55	O	-
58	L	-
59	Y	-

64	LG	-
65	GR	-
67	R	-
68	SB	-
70	R	-
71	LG	-
72	V	-
73	L	-
76	R	-
78	B	-
79	W	-
80	L	-
83	Y	-
84	LG	-
85	GR	-
86	O	-
87	SHIELD	-
81	G	-
92	R	-
95	BR	-
96	P	-
97	GR	-
98	W	-
99	V	-
100	O	-

Connector No.	F1
Connector Name	WIRE TO WIRE
Connector Type	SA038EP-RS-DS-122

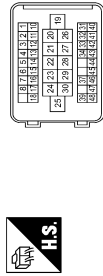

Terminal No.	Color Of Wire	Signal Name [Specification]
1	P	-
2	Y	-
3	Y	-
4	BG	-
5	LG	-
6	SB	-
7	G	-
8	R	-

10	BR	-
12	G	-
13	BG	-
14	L	-
15	BR	-
16	P	-
17	SB	-
18	G	-
19	G	-
20	BR	-
21	G	-
22	BR	-
23	SHIELD	-
24	R	-
25	G	-
26	G	-
27	B	-
28	R	-
29	W	-
30	R	-
31	BG	-
32	LG	-
33	BR	-
34	G	-
37	G	-
39	B	-
40	P	-
41	BR	-
42	Y	-
44	G	-
45	BR	-
46	R	-
47	Y	-
48	GR	-

Connector No.	F19
Connector Name	SECONDARY SPEED SENSOR
Connector Type	RK02EB



Terminal No.	Color Of Wire	Signal Name [Specification]
1	Y	-
2	R	-
3	LG	-

Connector No.	F27
Connector Name	TRANSMISSION RANGE SWITCH
Connector Type	RK02FC



Terminal No.	Color Of Wire	Signal Name [Specification]
1	GR	-
2	BR	-
3	LG	-
4	L	-
5	G	-
6	Y	-
7	W	-
8	V	-

A  
B  
C  
TM  
E  
F  
G  
H  
I  
J  
K  
L  
M  
N  
O  
P

# CVT CONTROL SYSTEM

< WIRING DIAGRAM >

[CVT: RE0F10B]

## CVT CONTROL SYSTEM

Connector No.	F31
Connector Name	CVT UNIT
Connector Type	Yazaki, 1293-3759-30

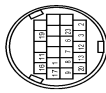

Terminal No.	Color Of Wire	Signal Name [Specification]
1	G	-
2	W	-
3	W	-
4	R	-
5	RG	-
6	V	-
7	GR	-
8	GR	-
9	G	-
10	L	-
11	L	-
12	L	-
13	L	-
14	W	-
15	W	-
16	Y	-
17	Y	-
18	LG	-
19	P	-
20	P	-
21	P	-
22	P	-
23	P	-

Connector No.	F55
Connector Name	PRIMARY SPEED SENSOR
Connector Type	TKD2FB



Terminal No.	Color Of Wire	Signal Name [Specification]
1	Y	-
2	BG	-
3	LG	-

Connector No.	F81
Connector Name	TCM (TRANSMISSION CONTROL MODULE)
Connector Type	RH40FB-RZB-L-RH

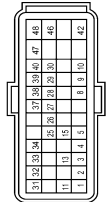

Terminal No.	Color Of Wire	Signal Name [Specification]
1	G	R RANGE SW
2	Y	N RANGE SW
3	W	D RANGE SW
4	V	-
5	B	GROUND
6	BR	CLOCK (SEL.2)
7	G	CHP SELECT (SEL.1)
8	G	DATE I/O (SEL.3)
9	W	P RANGE SW
10	L	-
11	L	CVT FLUID TEMPERATURE SENSOR
12	SB	SECONDARY PRESSURE SENSOR
13	P	SENSOR GROUND
14	Y	SENSOR POWER SUPPLY
15	LG	STEP MOTOR D
16	GR	STEP MOTOR C
17	RG	STEP MOTOR B
18	R	STEP MOTOR A
19	P	CAN-L
20	L	CAN-H
21	BG	PRIMARY SPEED SENSOR
22	R	SECONDARY SPEED SENSOR
23	L	LOCK-UP SELECT SOLENOID VALVE
24	G	TORQUE CONVERTER CLUTCH SOLENOID VALVE
25	W	SECONDARY PRESSURE SOLENOID VALVE
26	Y	LINE PRESSURE SOLENOID VALVE
27	B	GROUND
28	LG	IGNITION POWER SUPPLY
29	BG	BATTERY POWER SUPPLY MEMORY BACK-UP
30	Y	IGNITION POWER SUPPLY

Connector No.	F267
Connector Name	CONTROL VALVE
Connector Type	ARBW

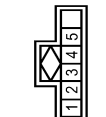

Terminal No.	Color Of Wire	Signal Name [Specification]
1	W/R	-
2	W/R	-
3	RG	-
4	G/W	-
5	B	-

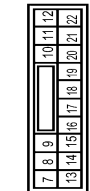

Connector No.	F268
Connector Name	CONTROL VALVE
Connector Type	JP18F-1

Terminal No.	Color Of Wire	Signal Name [Specification]
7	BR	-
8	R	-
9	G	-
10	Y/R	-
11	P	-
12	R/W	-
13	B	-
14	G	-
15	O	-
16	L/Y	-
17	GR	-
18	W	-
19	G/B	-
20	B/Y	-
21	G/R	-

Connector No.	22
Connector Name	Y
Connector Type	-

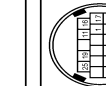

Terminal No.	Color Of Wire	Signal Name [Specification]
1	W/R	-
2	R	-
3	G	-
4	G	-
5	L	-
6	L	-
7	O	-
8	L/Y	-
9	GR	-
10	R/B	-
11	Y/R	-
12	Y/R	-
13	P	-
14	G/W	-
15	W	-
16	G/B	-
17	G/B	-
18	R/W	-
19	B/Y	-
20	B/Y	-
21	W	-

JRDWC1951GB

# CVT CONTROL SYSTEM

## CVT CONTROL SYSTEM

Connector No.	M4
Connector Name	DATA LINK CONNECTOR
Connector Type	EDBFW

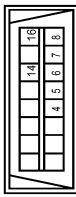

Terminal No.	Color	Wire	Signal Name [Specification]
1	B	GR	ILLUMINATION CONTROL SIGNAL (With front fog lamp)
2	GR	W	MANUAL MODE SHIFTER SIGNAL (Without front fog lamp)
3	GR	W	MANUAL MODE SHIFTER SIGNAL (Without front fog lamp)
4	GR	W	MANUAL MODE SHIFTER SIGNAL (Without front fog lamp)
5	GR	W	MANUAL MODE SHIFTER SIGNAL (Without front fog lamp)
6	GR	W	MANUAL MODE SHIFTER SIGNAL (Without front fog lamp)
7	GR	W	MANUAL MODE SHIFTER SIGNAL (Without front fog lamp)
8	GR	W	MANUAL MODE SHIFTER SIGNAL (Without front fog lamp)

Connector No.	M34
Connector Name	COMBINATION METER
Connector Type	TH40PW-NH

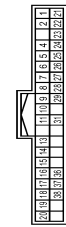

Terminal No.	Color	Wire	Signal Name [Specification]
1	L	L	CAN-H
2	P	P	CAN-L
4	V	V	VEHICLE SPEED SIGNAL (P-PULSED) (With front fog lamp)
4	Y	Y	VEHICLE SPEED SIGNAL (P-PULSED) (Without front fog lamp)
5	G	G	PADDLE SHIFTER UP SWITCH SIGNAL
6	BR	BR	FUEL LEVEL SENSOR SIGNAL
7	BR	BR	SECURITY LAMP CONT
8	Y	Y	SECURITY LAMP CONT
9	O	O	SECURITY LAMP CONT
9	W	W	SECURITY LAMP CONT
10	SB	SB	PARKING BRAKE SWITCH SIGNAL
11	G	G	BRAKE FLUID LEVEL SWITCH SIGNAL

## CVT CONTROL SYSTEM

Connector No.	M4
Connector Name	DATA LINK CONNECTOR
Connector Type	EDBFW



Terminal No.	Color	Wire	Signal Name [Specification]
13	B	GR	ILLUMINATION CONTROL SIGNAL (With front fog lamp)
14	GR	W	MANUAL MODE SHIFTER SIGNAL (Without front fog lamp)
14	GR	W	MANUAL MODE SHIFTER SIGNAL (Without front fog lamp)
15	L	L	ACC POWER SUPPLY
16	O	GR	MANUAL MODE SHIFTER DOWN SIGNAL (With front fog lamp)
16	W	GR	MANUAL MODE SHIFTER DOWN SIGNAL (Without front fog lamp)
17	G	GR	WASHER LEVEL SWITCH SIGNAL (Without front fog lamp)
17	W	GR	WASHER LEVEL SWITCH SIGNAL (Without front fog lamp)
18	R	P	SECURITY SIGNAL
19	GR	P	SECURITY SIGNAL
20	LG	P	AMBIENT SENSOR GROUND (With front fog lamp)
20	LG	P	AMBIENT SENSOR GROUND (Without front fog lamp)
21	B	B	GROUND
22	B	B	GROUND
23	L	L	GROUND
24	L	L	FUEL LEVEL SENSOR GROUND
25	B	B	VOC GROUND
26	V	V	PADDLE SHIFTER DOWN SWITCH SIGNAL
27	LG	P	BATTERY POWER SUPPLY
28	GR	P	IGNITION SIGNAL
29	LG	P	PASSENGER SEAT BELT WARNING SIGNAL (Without front fog lamp)
31	V	V	A/C AUTO AMP CONNECTION RECOGNITION SIGNAL
36	LG	P	MANUAL MODE SIGNAL (With front fog lamp)
36	Y	P	MANUAL MODE SIGNAL (Without front fog lamp)
37	G	P	NON-MANUAL MODE SIGNAL (Without front fog lamp)
38	P	P	ALTERNATOR SIGNAL

Connector No.	M57
Connector Name	CVT SHIFT SELECTOR
Connector Type	TH16FW-NH



Terminal No.	Color	Wire	Signal Name [Specification]
1	P	P	SECURITY LAMP CONT
2	B	B	SECURITY LAMP CONT
3	BR	BR	SECURITY LAMP CONT
4	B	B	SECURITY LAMP CONT
5	V	V	SECURITY LAMP CONT

## CVT CONTROL SYSTEM

Connector No.	M55
Connector Name	BCM (BODY CONTROL MODULE)
Connector Type	TH40FW-NH

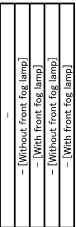

Terminal No.	Color	Wire	Signal Name [Specification]
9	GR	GR	ILLUMINATION CONTROL SIGNAL (With front fog lamp)
9	GR	W	MANUAL MODE SHIFTER SIGNAL (Without front fog lamp)
10	B	B	ACC POWER SUPPLY
11	G	GR	MANUAL MODE SHIFTER DOWN SIGNAL (Without front fog lamp)
12	SB	P	WASHER LEVEL SWITCH SIGNAL (Without front fog lamp)
12	G	GR	WASHER LEVEL SWITCH SIGNAL (Without front fog lamp)
13	G	GR	WASHER LEVEL SWITCH SIGNAL (Without front fog lamp)
13	P	P	SECURITY SIGNAL

Connector No.	M55
Connector Name	BCM (BODY CONTROL MODULE)
Connector Type	TH40FW-NH



Terminal No.	Color	Wire	Signal Name [Specification]
2	L	L	COMBI SW INPUT 5
3	GR	GR	COMBI SW INPUT 4
4	BR	BR	COMBI SW INPUT 3
5	BR	BR	COMBI SW INPUT 2
6	W	W	COMBI SW INPUT 1
7	L	L	KEY CYL UNLOCK SW
8	R	R	STOP LAMP SW
9	R	R	STOP LAMP SW
10	W	W	REAR WINDOW DEF SW
11	L	L	IGN SW ACC
12	Y	Y	DOOR LK & UNLK SW LOCK
13	BR	BR	DOOR LK & UNLK SW UNLOCK
15	W	W	RECEIVER GND
18	V	V	RECEIVER PWR SPLY
19	BR	BR	RECEIVER COMM
20	G	G	RECEIVER COMM
21	P	P	SECURITY LAMP CONT
24	SB	SB	SECURITY LAMP CONT
25	LG	P	MAT'S ANT AMP
26	B	B	THERMO CONT AMP
27	W	W	A/C SW
28	O	O	BLOWER FAN SW
29	L	L	HAZARD SW

## CVT CONTROL SYSTEM

Connector No.	M58
Connector Name	BCM (BODY CONTROL MODULE)
Connector Type	TH40BP-NH



Terminal No.	Color	Wire	Signal Name [Specification]
30	L	L	COMBI SW INPUT 5
31	G	GR	COMBI SW INPUT 4
32	L	GR	COMBI SW INPUT 3
33	V	BR	COMBI SW INPUT 2
34	V	W	COMBI SW INPUT 1
35	R	R	KEY CYL UNLOCK SW
36	P	P	STOP LAMP SW
37	GR	GR	REAR WINDOW DEF SW
38	R	R	IGN SW ON
39	L	L	CAN-H
40	P	P	CAN-L

Connector No.	M58
Connector Name	BCM (BODY CONTROL MODULE)
Connector Type	TH40BP-NH



Terminal No.	Color	Wire	Signal Name [Specification]
2	L	L	COMBI SW INPUT 5
3	GR	GR	COMBI SW INPUT 4
4	BR	BR	COMBI SW INPUT 3
5	BR	BR	COMBI SW INPUT 2
6	W	W	COMBI SW INPUT 1
7	L	L	KEY CYL UNLOCK SW
8	R	R	STOP LAMP SW
9	R	R	STOP LAMP SW 1
10	W	W	REAR WINDOW DEF SW
12	GR	GR	DOOR LK & UNLK SW LOCK (Without front fog lamp)
12	Y	Y	DOOR LK & UNLK SW LOCK (With front fog lamp)
13	BR	BR	DOOR LK & UNLK SW UNLOCK
14	P	P	OPTICAL SENS
15	W	W	RR DEFOGGER SW
18	R	R	OPTICAL SENS PWR SHLY
18	V	V	RECEIVER GND
19	BR	BR	MAT'S ANT AMP
23	B	B	SECURITY LAMP CONT
24	SB	SB	SECURITY LAMP CONT
25	LG	P	MAT'S ANT AMP
26	B	B	THERMO CONT AMP
27	W	W	A/C SW (With front fog lamp)
27	Y	Y	A/C SW (Without front fog lamp)

# CVT CONTROL SYSTEM

< WIRING DIAGRAM >

[CVT: RE0F10B]

**CVT CONTROL SYSTEM**

28	LG	BLU/RED SW (Without front fog lamp)
29	O	BLU/RED SW (With front fog lamp)
29	L	HAZARD SW (With front fog lamp)
29	SB	HAZARD SW (Without front fog lamp)
30	L	BK DOOR OPENER SW
31	GR	DR DOOR UNLK SENS
32	LG	COMBI SW OUTPUT 5
33	Y	COMBI SW OUTPUT 4
34	V	COMBI SW OUTPUT 3
35	R	COMBI SW OUTPUT 2
36	P	COMBI SW OUTPUT 1
37	G	DETENT SW
38	SB	RECEIVER COM1
39	L	GAN-H
40	P	GAN-L

Connector No.	M77
Connector Name	WIRE TO WIRE
Connector Type	TH86FW-C816-TM4

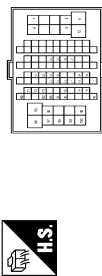

Terminal No.	Color Of Wire	Signal Name [Specification]
1	L	-
4	V	-
5	W	-
6	P	-
8	R	-
10	R	-
34	LG	-
35	SB	-
36	B	-
37	P	-
52	R	-
53	L	-
55	SB	-
55	P	-
58	LG	-
59	G	-
64	G	-
65	GR	-
66	Y	-

Connector No.	M7
Connector Name	PADDLE SHIFTER (SHIFT-UP)
Connector Type	AG8W



Terminal No.	Color Of Wire	Signal Name [Specification]
3	B	-
3	G	-

Connector No.	M24
Connector Name	CVT SHIFT SELECTOR
Connector Type	TH8BMV-NH



Terminal No.	Color Of Wire	Signal Name [Specification]
1	Y	-
2	Y	-
3	W	-
4	P	-
5	G	-
6	G	-
7	BR	-
8	G	-
9	GR	-
10	LW	-
12	O	-
13	LS	-

67	V	-
68	R	-
70	V	-
71	R	-
72	GR	-
72	G	-
76	W	-
78	LG	-
79	V	-
80	LG	-
83	P	-
84	G	-
85	BR	-
86	LG	-
87	Y	-
97	BR	-
95	R	- [Without Intelligent Key]
95	Y	- [With Intelligent Key]
96	L	-
97	GR	-
98	G	-
99	W	-
100	LG	-

Connector No.	M95
Connector Name	PADDLE SHIFTER (SHIFT-DOWN)
Connector Type	AG8PW

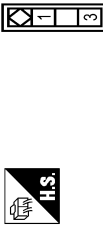

Terminal No.	Color Of Wire	Signal Name [Specification]
1	B	-
3	V	-

JRDWC1953GB

# CVT SHIFT LOCK SYSTEM

< WIRING DIAGRAM >

[CVT: RE0F10B]

## CVT SHIFT LOCK SYSTEM

### Wiring Diagram

INFOID:000000009752551

\*: This connector is not shown in "Harness Layout".

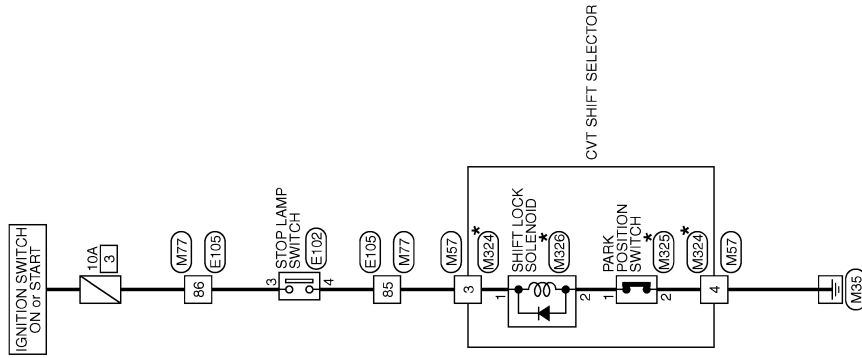

SHIFT LOCK SYSTEM

2010/08/30

JCDWA0672GB

A  
B  
C  
TM  
E  
F  
G  
H  
I  
J  
K  
L  
M  
N  
O  
P

# CVT SHIFT LOCK SYSTEM

< WIRING DIAGRAM >

[CVT: RE0F10B]

## SHIFT LOCK SYSTEM

Connector No.	E102
Connector Name	STOP LAMP SWITCH
Connector Type	M04FW-LC



Terminal No.	Color Of Wire	Signal Name [Specification]
1	SB	-
2	GR	-
3	GR	-
4	LG	-

Connector No.	E105
Connector Name	WIRE TO WIRE
Connector Type	TH8BFW-CSE-TM4

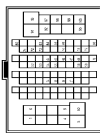

Terminal No.	Color Of Wire	Signal Name [Specification]
1	L	-
4	Y	-
5	GR	-
6	P	-
9	G	-
10	R	-
34	O	-
35	GR	-
37	B	-
52	B	-
53	L	-
54	P	-
55	P	-
59	LG	-
64	G	-
65	Y	-
66	Y	-
67	V	-
68	R	-
70	V	-
71	V	-
55	O	-
58	L	-

Terminal No.	Color Of Wire	Signal Name [Specification]
7	Y	-
8	W	-
9	R	-
10	B	-
11	G	-
12	SB	- [Without front fog lamp]
12	Y	- [With front fog lamp]
13	G	- [Without front fog lamp]
13	P	- [With front fog lamp]

Connector No.	M77
Connector Name	WIRE TO WIRE
Connector Type	TH8BFW-CSE-TM4

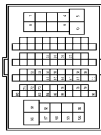

Terminal No.	Color Of Wire	Signal Name [Specification]
1	L	-
4	V	-
5	W	-
6	R	-
9	R	-
10	R	-
34	LG	-
35	SB	-
36	B	-
37	P	-
52	R	-
53	L	-
54	SB	-
55	P	-
59	LG	-
64	G	-
65	Y	-
66	Y	-
67	V	-
68	R	-
70	V	-
71	R	-
72	GR	-

Terminal No.	Color Of Wire	Signal Name [Specification]
73	G	-
74	W	-
75	LG	-
76	LG	-
79	V	-
80	LG	-
83	P	-
84	G	-
85	BR	-
86	LG	-
90	SHIELD	-
91	Y	-
92	BR	-
95	R	- [Without Intelligent Key]
95	Y	- [With Intelligent Key]
89	L	-
89	GR	-
86	G	-
88	W	-
89	W	-
100	LG	-

Connector No.	M324
Connector Name	CVT SHIFT SELECTOR
Connector Type	TH18BW-NH



Terminal No.	Color Of Wire	Signal Name [Specification]
1	Y	-
2	Y	-
3	W	-
4	P	-
5	G	-
6	G	-
7	BR	-
8	GR	-
9	GR	-
10	Y	-
11	L/W	-
12	O	-
13	LG	-

JRDWC1954GB



# CVT SHIFT LOCK SYSTEM

< WIRING DIAGRAM >

[CVT: RE0F10B]

A  
B  
C  
TM  
E  
F  
G  
H  
I  
J  
K  
L  
M  
N  
O  
P

**SHIFT LOCK SYSTEM**

Connector No.	M325
Connector Name	PARK POSITION SWITCH
Connector Type	TK02FW



Terminal No.	Color Of Wire	Signal Name [Specification]
1	-	-
2	-	-

Connector No.	M326
Connector Name	SHIFT LOCK SOLENOID
Connector Type	Yazaki: T283-5645



Terminal No.	Color Of Wire	Signal Name [Specification]
1	W	-
2	B	-

JRDWC1955GB

## BASIC INSPECTION

### DIAGNOSIS AND REPAIR WORKFLOW

#### Work Flow

INFOID:000000009752552

#### INTRODUCTION

The TCM receives a signal from the vehicle speed sensor, transmission range switch and provides shift control or lock-up control via CVT solenoid valves.

The TCM also communicates with the ECM by means of a signal sent from sensing elements used with the OBD-related parts of the CVT system for malfunction-diagnostic purposes. The TCM is capable of diagnosing malfunctioning parts while the ECM can store malfunctions in its memory.

Input and output signals must always be correct and stable in the operation of the CVT system. The CVT system must be in good operating condition and be free of valve seizure, solenoid valve malfunction, etc.

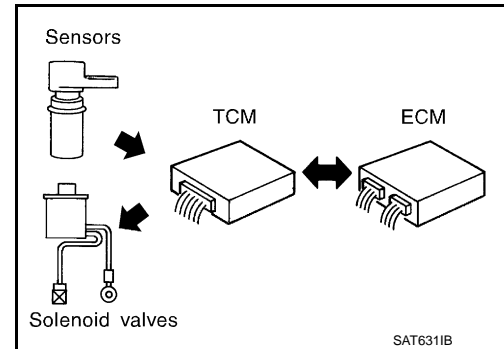

It is much more difficult to diagnose an error that occurs intermittently rather than continuously. Most intermittent errors are caused by poor electric connections or improper wiring. In this case, careful checking of suspected circuits may help prevent the replacement of good parts.

A visual check only may not find the cause of the errors. A road test with CONSULT (or GST) or a circuit tester connected should be performed. Follow the "DETAILED FLOW".

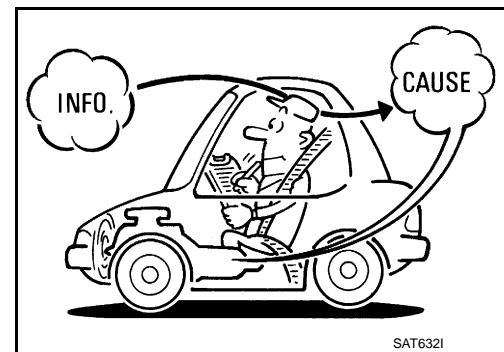

Before undertaking actual checks, take a few minutes to talk with a customer who approaches with a driveability complaint. The customer can supply good information about such errors, especially intermittent ones. Find out what symptoms are present and under what conditions they occur. A "Diagnostic Work Sheet" as shown on the example (Refer to [TM-211](#)) should be used.

Start your diagnosis by looking for "conventional" errors first. This will help troubleshoot driveability errors on an electronically controlled engine vehicle.

Also check related Service bulletins.

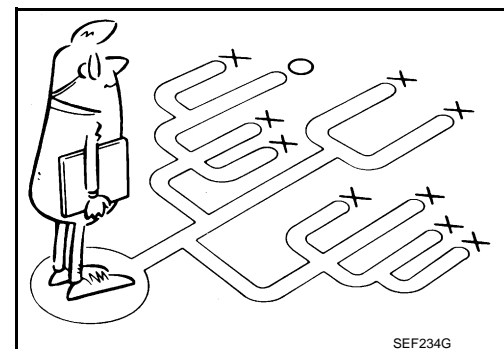

#### DETAILED FLOW

##### 1. COLLECT THE INFORMATION FROM THE CUSTOMER

Get the detailed information from the customer about the symptom (the condition and the environment when the incident/malfunction occurred) using diagnosis worksheet. Refer to [TM-211, "Diagnostic Work Sheet"](#).

>> GO TO 2.

##### 2. CHECK SYMPTOM 1

Check the following items based on the information obtained from the customer.

- Fail-safe. Refer to [TM-195, "Fail-Safe"](#).
- CVT fluid inspection. Refer to [TM-305, "Inspection"](#).
- Line pressure test. Refer to [TM-221, "Inspection and Judgment"](#).

# DIAGNOSIS AND REPAIR WORKFLOW

< BASIC INSPECTION >

[CVT: RE0F10B]

- Stall test. Refer to [TM-219, "Inspection and Judgment"](#).

>> GO TO 3.

## 3.CHECK DTC

1. Check DTC.
2. Perform the following procedure if DTC is detected.
  - Record DTC.
  - Erase DTC. Refer to [TM-183, "Diagnosis Description"](#).

Is any DTC detected?

- YES >> GO TO 4.  
NO >> GO TO 5.

## 4.PERFORM DIAGNOSTIC PROCEDURE

Perform "Diagnostic Procedure" for the displayed DTC.

>> GO TO 5.

## 5.PERFORM DTC CONFIRMATION PROCEDURE

Perform "DTC CONFIRMATION PROCEDURE" for the displayed DTC.

Is DTC detected?

- YES >> GO TO 4.  
NO >> GO TO 6.

## 6.CHECK SYMPTOM 2

Confirm the symptom described by the customer.

Is any malfunction present?

- YES >> GO TO 7.  
NO >> **INSPECTION END**

## 7.RODE TEST

Perform "RODE TEST". Refer to [TM-223, "Description"](#).

>> GO TO 8.

## 8.CHECK SYMPTOM 3

Confirm the symptom described by the customer.

Is any malfunction present?

- YES >> GO TO 2.  
NO >> **INSPECTION END**

## Diagnostic Work Sheet

INFOID:000000009752553

### INFORMATION FROM CUSTOMER

#### KEY POINTS

- **WHAT**..... Vehicle & CVT model
- **WHEN**..... Date, Frequencies
- **WHERE**..... Road conditions
- **HOW**..... Operating conditions, Symptoms

Customer name MR/MS	Model & Year	VIN
Trans. Model	Engine	Mileage
Malfunction Date	Manuf. Date	In Service Date
Frequency	<input type="checkbox"/> Continuous <input type="checkbox"/> Intermittent ( times a day)	



# ADDITIONAL SERVICE WHEN REPLACING TCM

< BASIC INSPECTION >

[CVT: RE0F10B]

## ADDITIONAL SERVICE WHEN REPLACING TCM

### Description

INFOID:000000009752554

When replacing the TCM, perform the following work.

#### LOADING AND STORING OF CALIBRATION DATA

- The TCM acquires calibration data (individual characteristic value) of each solenoid that is stored in the ROM assembly (in the control valve). This enables the TCM to perform accurate control. After the TCM is replaced, check that the calibration data is correctly loaded and stored.

### Procedure

INFOID:000000009752555

#### CAUTION:

**Immediately after TCM is replaced or after control valve or transaxle assembly is replaced (after TCM initialization is complete), self-diagnosis result of "P1701", "P1709" may be displayed. In this case, erase self-diagnosis result using CONSULT. After erasing self-diagnosis result, perform DTC "P1701", "P1709" reproduction procedure and check that malfunction is not detected. Refer to [TM-272, "DTC Logic" \(P1701\)](#), [TM-276, "DTC Logic" \(P1709\)](#).**

### 1. LOAD CALIBRATION DATA

1. Shift the selector lever to the "P" position.
2. Turn ignition switch ON.
3. Check that "P" is displayed on shift position indicator on combination meter.

#### NOTE:

Displayed approximately 1 – 2 seconds after the selector lever is moved to the "P" position.

Does the shift position indicator display "P"?

- YES >> GO TO 3.  
NO >> GO TO 2.

### 2. DETECT MALFUNCTIONING ITEM

Check the following items:

- Harness between the TCM and the ROM assembly inside the transaxle assembly is open or shorted.
- Disconnected, loose, bent, collapsed, or otherwise abnormal connector housing terminals

Is the inspection result normal?

- YES >> GO TO 1.  
NO >> Repair or replace the malfunctioning parts.

### 3. STORE CALIBRATION DATA

1. Turn ignition switch OFF and wait for 5 seconds.
2. Turn ignition switch ON.

Does the shift position indicator display "P" at the same time when turning ON the ignition switch?

- YES >> WORK END  
NO >> Check harness between battery and TCM harness connector terminal. Refer to [TM-272, "Diagnosis Procedure"](#).

# ADDITIONAL SERVICE WHEN REPLACING CONTROL VALVE OR TRANSAXLE ASSEMBLY

< BASIC INSPECTION >

[CVT: RE0F10B]

## ADDITIONAL SERVICE WHEN REPLACING CONTROL VALVE OR TRANSAXLE ASSEMBLY

### Description

INFOID:000000009752556

When replacing the transaxle assembly/control valve, perform the following work.

#### ERASING, LOADING AND STORING OF CALIBRATION DATA

- The TCM acquires calibration data (individual characteristic value) of each solenoid that is stored in the ROM assembly (in the control valve). This enables the TCM to perform accurate control. For this reason, after the transaxle assembly/control valve is replaced, it is necessary to erase the calibration data previously stored in TCM, to load new calibration data, and to store them.

#### ERASING OF CVT FLUID DEGRADATION LEVEL DATA

- TCM records the degradation level of the CVT fluid calculated from the vehicle driving status. Therefore, if the transaxle assembly/control valve is replaced, it is necessary to erase the CVT fluid degradation level data recorded by TCM.

### Procedure

INFOID:000000009752557

#### CAUTION:

Immediately after TCM is replaced or after control valve or transaxle assembly is replaced (after TCM initialization is complete), self-diagnosis result of "P1701", "P1709" may be displayed. In this case, erase self-diagnosis result using CONSULT. After erasing self-diagnosis result, perform DTC "P1701", "P1709" reproduction procedure and check that malfunction is not detected. Refer to [TM-272, "DTC Logic" \(P1701\)](#), [TM-276, "DTC Logic" \(P1709\)](#).

### 1. PREPARATION BEFORE WORK

#### Ⓜ With CONSULT

1. Start the engine.

#### CAUTION:

**Never drive the vehicle.**

2. Select "Data Monitor" in "TRANSMISSION".
3. Select "ATFTEMP COUNT".

Is "ATFTEMP COUNT" 47 [equivalent to 20°C (68°F)] or more?

YES >> GO TO 2.

- NO >> 1. Warm up the transaxle assembly until "ATFTEMP COUNT" reaches "47" [equivalent to 20°C (68°F)] or more.
2. GO TO 2.

### 2. PERFORM TCM INITIALIZATION

#### Ⓜ With CONSULT

1. Turn ignition switch OFF.
  2. Turn ignition switch ON.
- #### CAUTION:
- Never start the engine.**
3. Select "Self Diagnostic Results" in "TRANSMISSION".
  4. Shift selector lever to "R" position.
  5. Depress slightly the accelerator pedal (Pedal angle: 2.0/8) while depressing the brake pedal.
  6. Select "Erase" with step 5.
  7. Release brake pedal and accelerator pedal.
  8. Select "CALIB DATA" in "TRANSMISSION".
  9. Check that "CALIB DATA" value is as shown as in the following table.

Item name	Display value
UNIT CLB ID 1	00
UNIT CLB ID 2	00
UNIT CLB ID 3	00
UNIT CLB ID 4	00

# ADDITIONAL SERVICE WHEN REPLACING CONTROL VALVE OR TRANSAXLE ASSEMBLY

< BASIC INSPECTION >

[CVT: RE0F10B]

Item name	Display value
UNIT CLB ID 5	00
UNIT CLB ID 6	00

Is "CALIB DATA" value it?

- YES >> GO TO 3.
- NO >> GO TO 1.

## 3. LOAD CALIBRATION DATA

1. Shift selector lever to "P" position.
2. Check that "P" is displayed on shift position indicator on combination meter.

**NOTE:**

It indicates approximately 1 – 2 seconds after shifting the selector lever to "P" position.

Does shift position indicator display "P"?

- YES >> GO TO 5.
- NO >> GO TO 4.

## 4. DETECT MALFUNCTIONING ITEM

Check the following items:

- Harness between the TCM and the ROM assembly inside the transaxle assembly is open or shorted.
- Disconnected, loose, bent, collapsed, or otherwise abnormal connector housing terminals
- Power supply and ground of TCM. (Refer to [TM-272. "Diagnosis Procedure".](#))

Is the inspection result normal?

- YES >> GO TO 1.
- NO >> Repair or replace the malfunctioning parts.

## 5. STORE CALIBRATION DATA

1. Turn ignition switch OFF and wait for 5 seconds.
2. Turn ignition switch ON.

Does the shift position indicator display "P" at the same time when turning ON the ignition switch?

- YES >> GO TO 6.
- NO >> Check harness between battery and TCM harness connector terminal. Refer to [TM-272. "Diagnosis Procedure".](#)

## 6. ERASE CVT FLUID DEGRADATION LEVEL DATA

 **With CONSULT**

1. Select "WORK SUPPORT" in "TRANSMISSION".
2. Select "CONFORM CVTF DETERIORATION".
3. Touch "Clear".

>> WORK END

## CVT FLUID COOLER SYSTEM

### Cleaning

INFOID:000000009752558

Whenever an automatic transaxle is repaired, overhauled, or replaced, the CVT fluid cooler mounted in the radiator must be inspected and cleaned.

Metal debris and friction material, if present, can be trapped or be deposited in the CVT fluid cooler. This debris can contaminate the newly serviced CVT or, in severe cases, can block or restrict the flow of CVT fluid. In either case, malfunction of the newly serviced CVT may occur.

Debris, if present, may deposit as CVT fluid enters the cooler inlet. It will be necessary to back flush the cooler through the cooler outlet in order to flush out any built up debris.

### CVT FLUID COOLER CLEANING PROCEDURE

1. Position an oil pan under the transaxle's inlet and outlet cooler hoses.
2. Identify the inlet and outlet fluid cooler hoses.
3. Disconnect the fluid cooler inlet and outlet rubber hoses from the steel cooler tubes or bypass valve.

**NOTE:**

Replace the cooler hoses if rubber material from the hose remains on the tube fitting.

4. Allow any CVT fluid that remains in the cooler hoses to drain into the oil pan.

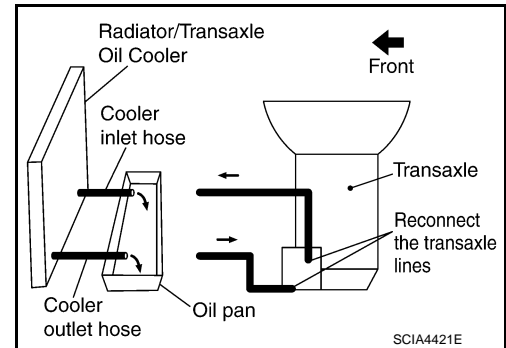

5. Insert the extension adapter hose of a can of Transmission Cooler Cleaner (Nissan P/N 999MP-AM006) into the cooler outlet hose.

**CAUTION:**

- **Wear safety glasses and rubber gloves when spraying the Transmission Cooler Cleaner.**
- **Spray Transmission Cooler Cleaner only with adequate ventilation.**
- **Avoid contact with eyes and skin.**
- **Never breath vapors or spray mist.**

6. Hold the hose and can as high as possible and spray Transmission Cooler Cleaner in a continuous stream into the cooler outlet hose until CVT fluid flows out of the cooler inlet hose for 5 seconds.

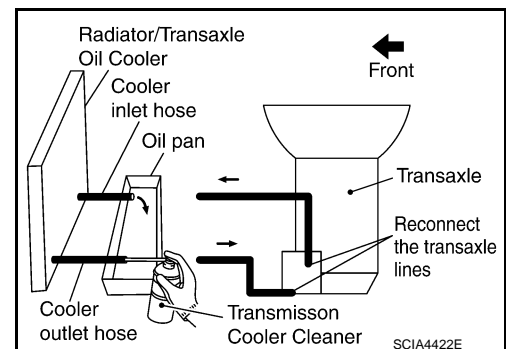

7. Insert the tip of an air gun into the end of the cooler outlet hose.
8. Wrap a shop rag around the air gun tip and end of the cooler outlet hose.

9. Blow compressed air regulated to 5 to 9 kg/cm<sup>2</sup> (70 to 130 psi) through the cooler outlet hose for 10 seconds to force out any remaining CVT fluid.

10. Repeat steps 5 through 9 three additional times.

11. Position an oil pan under the banjo bolts that connect the CVT fluid cooler steel lines to the transaxle.

12. Remove the banjo bolts.

13. Flush each steel line from the cooler side back toward the transaxle by spraying Transmission Cooler Cleaner in a continuous stream for 5 seconds.

14. Blow compressed air regulated to 5 to 9 kg/cm<sup>2</sup> (70 to 130 psi) through each steel line from the cooler side back toward the transaxle for 10 seconds to force out any remaining CVT fluid.

15. Ensure all debris is removed from the steel cooler lines.

16. Ensure all debris is removed from the banjo bolts and fittings.

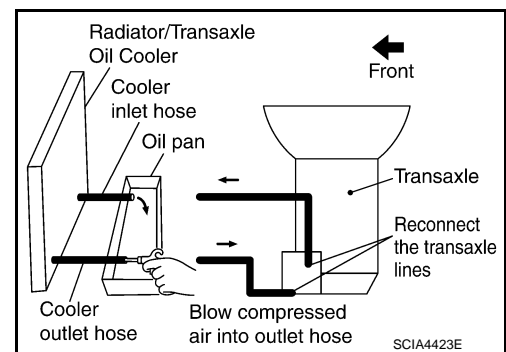



# CVT FLUID COOLER SYSTEM

< BASIC INSPECTION >

[CVT: RE0F10B]

17. Perform "CVT FLUID COOLER DIAGNOSIS PROCEDURE".

## CVT FLUID COOLER DIAGNOSIS PROCEDURE

### NOTE:

Insufficient cleaning of the cooler inlet hose exterior may lead to inaccurate debris identification.

1. Position an oil pan under the transaxle's inlet and outlet cooler hoses.
2. Clean the exterior and tip of the cooler inlet hose.
3. Insert the extension adapter hose of a can of Transmission Cooler Cleaner (Nissan P/N 999MP-AM006) into the cooler outlet hose.

### CAUTION:

- **Wear safety glasses and rubber gloves when spraying the Transmission Cooler Cleaner.**
- **Spray Transmission Cooler Cleaner only with adequate ventilation.**
- **Avoid contact with eyes and skin.**
- **Never breath vapors or spray mist.**

4. Hold the hose and can as high as possible and spray Transmission Cooler Cleaner in a continuous stream into the cooler outlet hose until CVT fluid flows out of the cooler inlet hose for 5 seconds.
5. Tie a common white, basket-type coffee filter to the end of the cooler inlet hose.

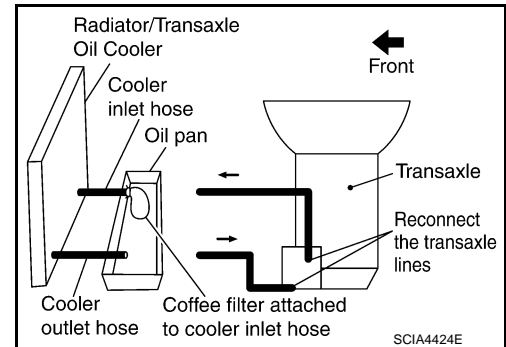
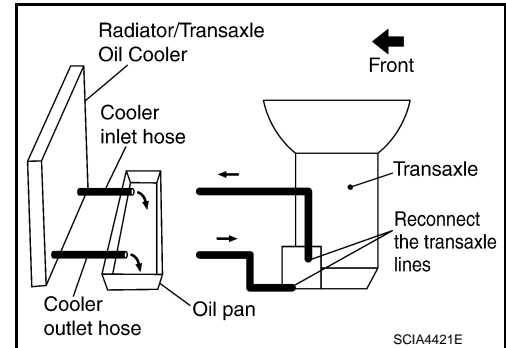

6. Insert the tip of an air gun into the end of the cooler outlet hose.
7. Wrap a shop rag around the air gun tip and end of cooler outlet hose.
8. Blow compressed air regulated to 5 to 9 kg/cm<sup>2</sup> (70 to 130 psi) through the cooler outlet hose to force any remaining CVT fluid into the coffee filter.
9. Remove the coffee filter from the end of the cooler inlet hose.
10. Perform "CVT FLUID COOLER INSPECTION PROCEDURE".

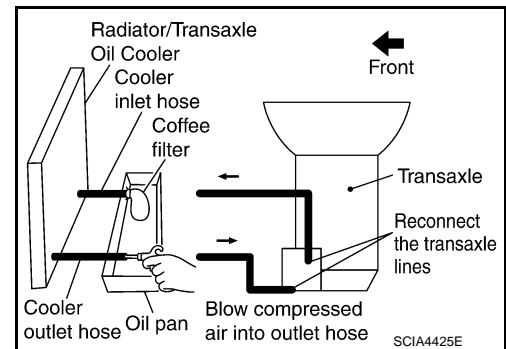

## CVT FLUID COOLER INSPECTION PROCEDURE

1. Inspect the coffee filter for debris.
  - a. If small metal debris less than 1 mm (0.040 in) in size or metal powder is found in the coffee filter, this is normal. If normal debris is found, the CVT fluid cooler/radiator can be reused and the procedure is ended.

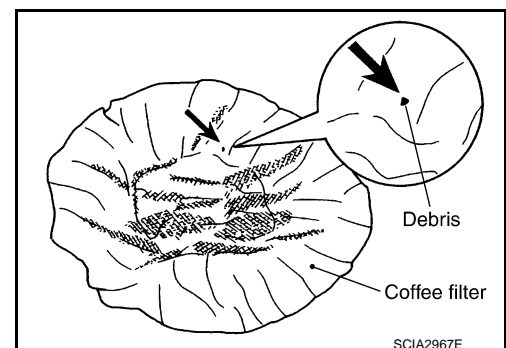

# CVT FLUID COOLER SYSTEM

[CVT: RE0F10B]

## < BASIC INSPECTION >

- b. If one or more pieces of debris are found that are over 1 mm (0.040 in) in size and/or peeled clutch facing material is found in the coffee filter, the fluid cooler is not serviceable. The radiator/ fluid cooler must be replaced and the inspection procedure is ended.

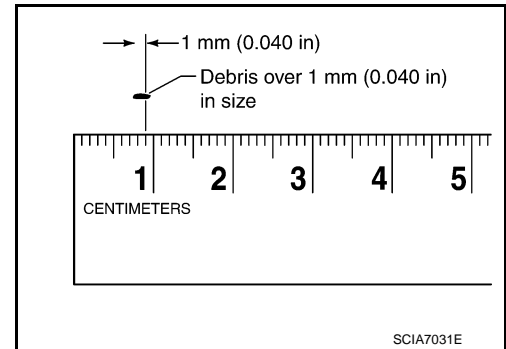

## CVT FLUID COOLER FINAL INSPECTION

After performing all procedures, ensure that all remaining oil is cleaned from all components.

## STALL TEST

### Inspection and Judgment

INFOID:000000009752559

#### INSPECTION

1. Inspect the amount of engine oil. Replenish the engine oil if necessary.
2. Drive for about 10 minutes to warm up the vehicle so that the CVT fluid temperature is 50 to 80°C (122 to 176°F). Inspect the amount of CVT fluid. Replenish if necessary.

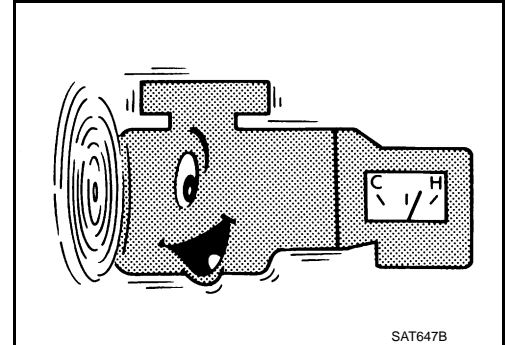

3. Securely engage the parking brake so that the tires do not turn.
4. Install a tachometer where it can be seen by driver during test.  
**NOTE:**  
It is good practice to mark the point of specified engine rpm on indicator.
5. Start engine, apply foot brake, and place selector lever in "D" position.

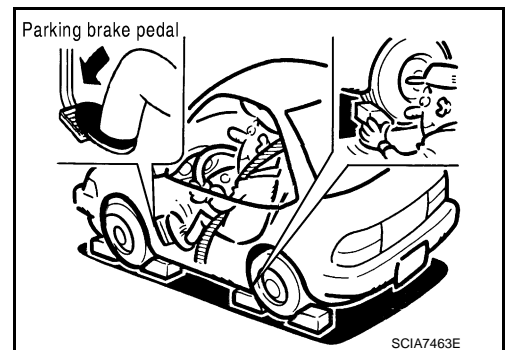

6. While holding down the foot brake, gradually press down the accelerator pedal.
7. Quickly read off the stall speed, and then quickly remove your foot from the accelerator pedal.  
**CAUTION:**  
**Never hold down the accelerator pedal for more than 5 seconds during this test.**

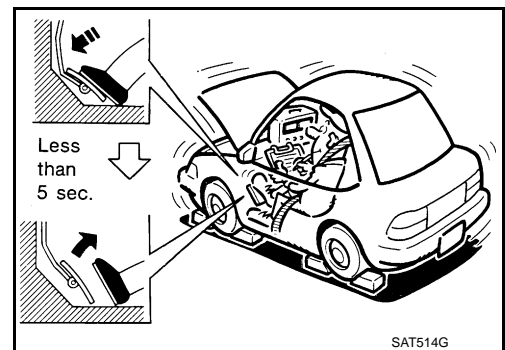

**Stall speed** : Refer to [TM-348, "Stall Speed"](#).

8. Move the selector lever to the "N" position.
9. Cool down the CVT fluid.  
**CAUTION:**  
**Run the engine at idle for at least 1 minute.**
10. Repeat steps 6 through 9 with selector lever in "R" position.

#### JUDGMENT

A  
B  
C  
TM  
E  
F  
G  
H  
I  
J  
K  
L  
M  
N  
O  
P

# STALL TEST

< BASIC INSPECTION >

[CVT: RE0F10B]

	Selector lever position		Expected problem location
	"D"	"R"	
Stall rotation	H	O	<ul style="list-style-type: none"> <li>• Forward clutch</li> </ul>
	O	H	<ul style="list-style-type: none"> <li>• Reverse brake</li> </ul>
	L	L	<ul style="list-style-type: none"> <li>• Engine and torque converter one-way clutch</li> </ul>
	H	H	<ul style="list-style-type: none"> <li>• Line pressure low</li> <li>• Primary pulley</li> <li>• Secondary pulley</li> <li>• Steel belt</li> </ul>

O: Stall speed within standard value position.

H: Stall speed is higher than standard value.

L: Stall speed is lower than standard value.

# LINE PRESSURE TEST

< BASIC INSPECTION >

[CVT: RE0F10B]

## LINE PRESSURE TEST

### Inspection and Judgment

INFOID:000000009752560

### INSPECTION

#### Line Pressure Test Port

A : Line pressure test port

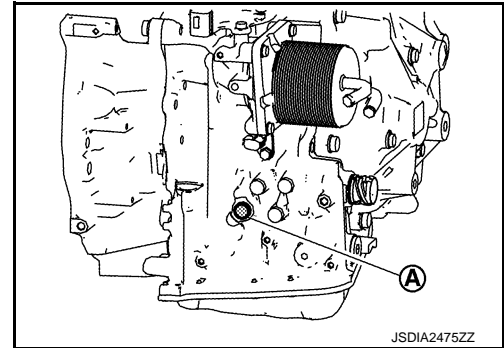

#### Line Pressure Test Procedure

1. Inspect the amount of engine oil and replenish if necessary.
2. Drive the car for about 10 minutes to warm it up so that the CVT fluid reaches in the range of 50 to 80°C (122 to 176°F), then inspect the amount of CVT fluid and replenish if necessary.

**NOTE:**

**The CVT fluid temperature rises in the range of 50 to 80°C (122 to 176°F) during 10 minutes of driving.**

3. After warming up CVT, remove the oil pressure detection plug and install the joint pipe adapter (SST: KV31103600) (A), adapter (SST: 25054000) (B), oil pressure gauge set (commercial service tool) (C).

**CAUTION:**

**When using the oil pressure gauge, be sure to use the O-ring attached to the oil pressure detection plug.**

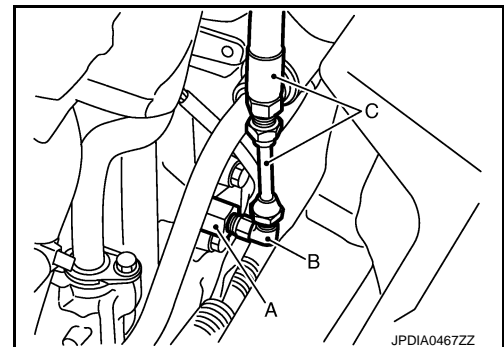

4. Securely engage the parking brake so that the tires do not turn.

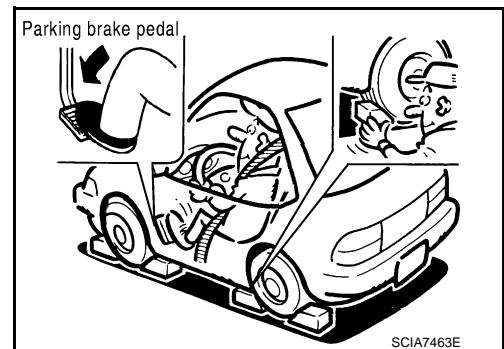

# LINE PRESSURE TEST

[CVT: RE0F10B]

## < BASIC INSPECTION >

5. Start the engine, and then measure the line pressure at both idle and the stall speed.

**CAUTION:**

- Keep the brake pedal pressed all the way down during measurement.
- When measuring the line pressure at the stall speed, refer to [TM-219, "Inspection and Judgment"](#).

Line pressure : Refer to [TM-348, "Line Pressure"](#).

6. After the measurements are complete, install the oil pressure detection plug and tighten to the specified torque below.

 : 7.5 N·m (0.77 kg·m, 66 in·lb)

**CAUTION:**

- Never reuse O-ring.
- Apply CVT fluid to O-ring.

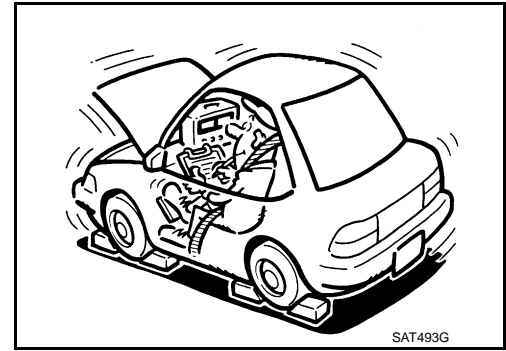

## JUDGMENT

Judgment		Possible cause
Idle speed	Low for all positions ("P", "R", "N", "D")	Possible causes include malfunctions in the pressure supply system and low oil pump output. For example <ul style="list-style-type: none"> <li>• Oil pump wear</li> <li>• Pressure regulator valve or plug sticking or spring fatigue</li> <li>• Oil strainer ⇒ oil pump ⇒ pressure regulator valve passage oil leak</li> <li>• Engine idle speed too low</li> </ul>
	Only low for a specific position	Possible causes include an oil pressure leak in a passage or device related to the position after the pressure is distributed by the manual valve.
	High	Possible causes include a sensor malfunction or malfunction in the line pressure adjustment function. For example <ul style="list-style-type: none"> <li>• Accelerator pedal position signal malfunction</li> <li>• CVT fluid temperature sensor malfunction</li> <li>• Line pressure solenoid malfunction (sticking in OFF state, filter clog, cut line)</li> <li>• Pressure regulator valve or plug sticking</li> </ul>
Stall speed	Line pressure does not rise higher than the line pressure for idle.	Possible causes include a sensor malfunction or malfunction in the pressure adjustment function. For example <ul style="list-style-type: none"> <li>• Accelerator pedal position signal malfunction</li> <li>• TCM malfunction</li> <li>• Line pressure solenoid malfunction (shorting, sticking in ON state)</li> <li>• Pressure regulator valve or plug sticking</li> </ul>
	The pressure rises, but does not enter the standard position.	Possible causes include malfunctions in the pressure supply system and malfunction in the pressure adjustment function. For example <ul style="list-style-type: none"> <li>• Accelerator pedal position signal malfunction</li> <li>• Line pressure solenoid malfunction (sticking, filter clog)</li> <li>• Pressure regulator valve or plug sticking</li> </ul>
	Only low for a specific position	Possible causes include an oil pressure leak in a passage or device related to the position after the pressure is distributed by the manual valve.

## ROAD TEST

## Description

INFOID:000000009752561

## DESCRIPTION

- The purpose of the test is to determine overall performance of CVT and analyze causes of problems.
- The road test consists of the following three parts:
  1. "Check Before Engine Is Started" [TM-223](#).
  2. "Check at Idle" [TM-223](#).
  3. "Cruise Test" [TM-224](#).

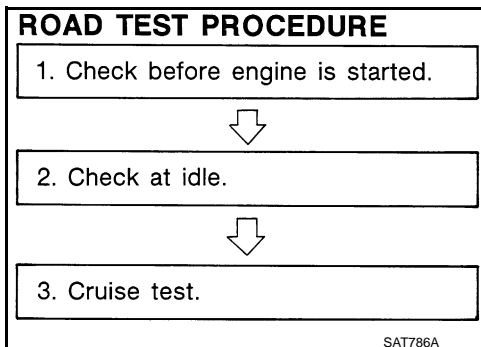

- Before road test, familiarize yourself with all test procedures and items to check.
- Perform tests on all items until specified symptom is found. Troubleshoot items the malfunctioning items after road test.



## Check before Engine Is Started

INFOID:000000009752562

## 1. CHECK CVT INDICATOR LAMP

1. Park vehicle on flat surface.
2. Move selector lever to "P" position.
3. Turn ignition switch OFF. Wait at least 5 seconds.
4. Turn ignition switch ON. (Do not start engine.)

Is shift position indicator activated for about 2 seconds?

- YES >> 1. Turn ignition switch OFF.  
 2. Perform self-diagnosis and note NG items.  
 Refer to [TM-185, "CONSULT Function"](#).  
 3. Go to [TM-223, "Check at Idle"](#).
- NO >> Stop "Road Test". Refer to [TM-294, "Symptom Table"](#).

## Check at Idle

INFOID:000000009752563

## 1. CHECK STARTING THE ENGINE

1. Park vehicle on flat surface.
2. Move selector lever to "P" or "N" position.
3. Turn ignition switch OFF.
4. Turn ignition switch to "START" position.

Is engine started?

- YES >> GO TO 2.
- NO >> Stop "Road Test". Refer to [TM-294, "Symptom Table"](#).

## 2. CHECK STARTING THE ENGINE

1. Turn ignition switch ON.
2. Move selector lever to "D", "M" or "R" position.
3. Turn ignition switch to "START" position.

# ROAD TEST

[CVT: RE0F10B]

## < BASIC INSPECTION >

### Is engine started?

- YES >> Stop "Road Test". Refer to [TM-294, "Symptom Table"](#).  
NO >> GO TO 3.

### 3.CHECK "P" POSITION FUNCTION

1. Move selector lever to "P" position.
2. Turn ignition switch OFF.
3. Release parking brake.
4. Push vehicle forward or backward.
5. Apply parking brake.

### Does vehicle move forward or backward?

- YES >> Refer to [TM-294, "Symptom Table"](#). Continue "Road Test".  
NO >> GO TO 4.

### 4.CHECK "N" POSITION FUNCTION

1. Start engine.
2. Move selector lever to "N" position.
3. Release parking brake.

### Does vehicle move forward or backward?

- YES >> Refer to [TM-294, "Symptom Table"](#). Continue "Road Test".  
NO >> GO TO 5.

### 5.CHECK SHIFT SHOCK

1. Apply foot brake.
2. Move selector lever to "R" position.

### Is there large shock when changing from "N" to "R" position?

- YES >> Refer to [TM-294, "Symptom Table"](#). Continue "Road Test".  
NO >> GO TO 6.

### 6.CHECK "R" POSITION FUNCTION

Release foot brake for several seconds.

### Does vehicle creep backward when foot brake is released?

- YES >> GO TO 7.  
NO >> Refer to [TM-294, "Symptom Table"](#). Continue "Road Test".

### 7.CHECK "D" POSITION FUNCTION

Move selector lever to "D" position and check if vehicle creeps forward.

### Does vehicle creep forward in all positions?

- YES >> Go to [TM-224, "Cruise Test"](#).  
NO >> Stop "Road Test". Refer to [TM-294, "Symptom Table"](#).

## Cruise Test

INFOID:000000009752564

### 1.CHECK VEHICLE SPEED WHEN SHIFTING GEARS — PART 1

1. Drive vehicle for approximately 10 minutes to warm engine oil and CVT fluid up to operating temperature.

**CVT fluid operating temperature: 50 – 80°C (122 – 176°F)**

2. Park vehicle on flat surface.
3. Move selector lever to "P" position.
4. Start engine.
5. Move selector lever to "D" position.



# ROAD TEST

[CVT: RE0F10B]

## < BASIC INSPECTION >

6. Accelerate vehicle to 2/8-way throttle depressing accelerator pedal constantly.

 Read vehicle speed and engine speed. Refer to [TM-348, "Shift Characteristics"](#).

### OK or NG

OK >> GO TO 2.

NG >> Refer to [TM-294, "Symptom Table"](#). Continue "Road Test".

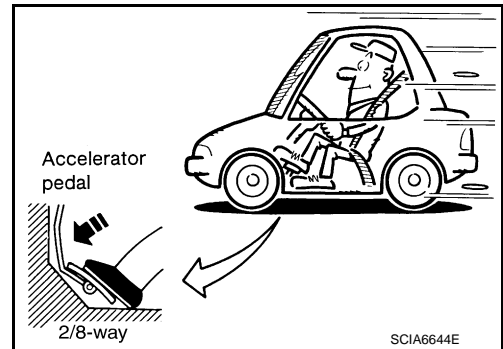

## 2.CHECK VEHICLE SPEED WHEN SHIFTING GEARS — PART 2

1. Park vehicle on flat surface.
2. Move selector lever to "D" position.
3. Accelerate vehicle to full depression depressing accelerator pedal constantly.

 Read vehicle speed and engine speed. Refer to [TM-348, "Shift Characteristics"](#).

### OK or NG

OK >> GO TO 3.

NG >> Refer to [TM-294, "Symptom Table"](#). Continue "Road Test".

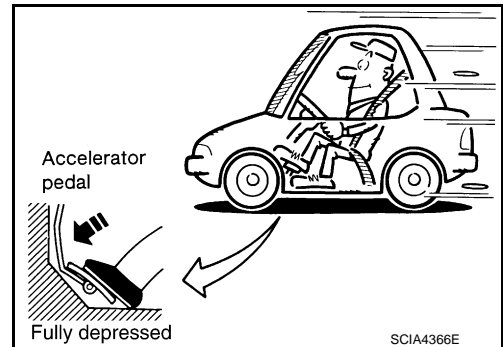

## 3.CHECK MANUAL MODE FUNCTION

Move to manual mode from "D" position.

Does it switch to manual mode?

YES >> GO TO 4.

NO >> Refer to [TM-294, "Symptom Table"](#). Continue "Road Test".

## 4.CHECK SHIFT-UP FUNCTION

During manual mode driving, is upshift from M1 → M2 → M3 → M4 → M5 → M6 performed?

 Read the gear position. Refer to [TM-185, "CONSULT Function"](#).

Is upshifting correctly performed?

YES >> GO TO 5.

NO >> Refer to [TM-294, "Symptom Table"](#). Continue "Road Test".

## 5.CHECK SHIFT-DOWN FUNCTION

During manual mode driving, is downshift from M6 → M5 → M4 → M3 → M2 → M1 performed?

 Read the gear position. Refer to [TM-185, "CONSULT Function"](#).

Is downshifting correctly performed?

YES >> GO TO 6.

NO >> Refer to [TM-294, "Symptom Table"](#). Continue "Road Test".

## 6.CHECK ENGINE BRAKE FUNCTION

Check engine brake.

Does engine braking effectively reduce speed in M1 position?

YES >> 1. Stop the vehicle.

2. Perform self-diagnosis. Refer to [TM-185, "CONSULT Function"](#).

NO >> Refer to [TM-294, "Symptom Table"](#). Then continue trouble diagnosis.

A  
B  
C  
TM  
E  
F  
G  
H  
I  
J  
K  
L  
M  
N  
O  
P

## CVT POSITION

## Inspection and Adjustment

INFOID:00000009752565

## INSPECTION

1. Place selector lever in "P" position, and turn ignition switch ON (engine stop).
2. Make sure that selector lever can be shifted to other than "P" position when brake pedal is depressed. Also make sure that selector lever can be shifted from "P" position only when brake pedal is depressed.
3. Move the selector lever and check for excessive effort, sticking, noise or rattle.
4. Confirm the selector lever stops at each position with the feel of engagement when it is moved through all the positions. Check that the actual position of the selector lever matches the position shown by the shift position indicator and the manual lever on the transaxle.
5. The method of operating the selector lever to individual positions correctly should be as shown.
6. When selector button is pressed in "P", "R" or "N" position without applying forward/backward force to selector lever, check button operation for sticking.
7. Confirm the back-up lamps illuminate only when selector lever is placed in the "R" position. Confirm the back-up lamps do not illuminate when the selector lever is pushed toward the "R" position when in the "P" or "N" position.
8. Confirm the engine can only be started with the selector lever in the "P" and "N" positions.
9. Make sure transaxle is locked completely in "P" position.
10. When selector lever is set to manual shift gate, make sure that manual mode is displayed on combination meter.  
Shift selector lever to "+" and "-" sides, and check that set shift position changes.

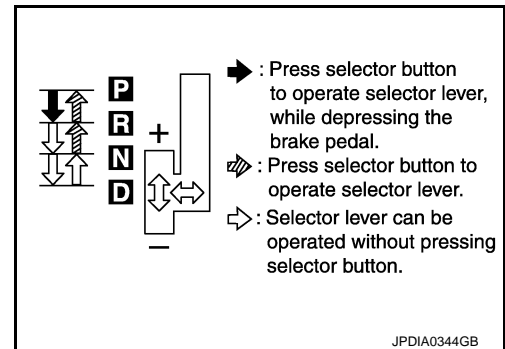

## ADJUSTMENT

1. Place selector lever in "P" position.  
**CAUTION:**  
**Turn wheels more than 1/4 rotations and apply the park lock.**
2. Loosen nut (A) and place manual lever (B) in "P" position.  
**CAUTION:**  
**Never apply any force to the manual lever.**
3. Tighten nut. Refer to [TM-311, "Removal and Installation"](#).  
**CAUTION:**  
**Fix the manual lever when tightening.**

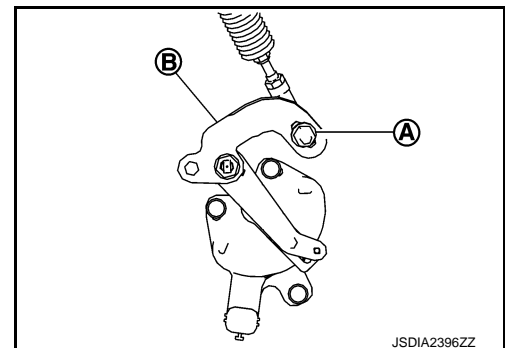

# U0100 LOST COMMUNICATION (ECM A)

< DTC/CIRCUIT DIAGNOSIS >

[CVT: RE0F10B]

## DTC/CIRCUIT DIAGNOSIS

### U0100 LOST COMMUNICATION (ECM A)

#### DTC Logic

INFOID:000000009752566

#### DTC DETECTION LOGIC

DTC	Trouble diagnosis name	DTC detection condition	Possible causes
U0100	Lost Communication With ECM/PCM A	When the ignition switch is ON, TCM is unable to receive the CAN communications signal from ECM continuously for 2 seconds or more.	<ul style="list-style-type: none"><li>• ECM</li><li>• Harness or connector (CAN communication line is open or shorted)</li></ul>

#### DTC CONFIRMATION PROCEDURE

##### 1. PREPARATION BEFORE WORK

If another "DTC CONFIRMATION PROCEDURE" occurs just before, turn ignition switch OFF and wait for at least 10 seconds, then perform the next test.

>> GO TO 2.

##### 2. PERFORM DTC CONFIRMATION PROCEDURE

1. Start the engine and wait for at least 5 seconds.
2. Check the first trip DTC.

Is "U0100" detected?

- YES >> Go to [TM-227. "Diagnosis Procedure"](#).  
NO >> INSPECTION END

#### Diagnosis Procedure

INFOID:000000009752567

For the diagnosis procedure, refer to [LAN-15. "Trouble Diagnosis Flow Chart"](#).

# U1000 CAN COMM CIRCUIT

< DTC/CIRCUIT DIAGNOSIS >

[CVT: RE0F10B]

## U1000 CAN COMM CIRCUIT

### Description

INFOID:000000009752568

CAN (Controller Area Network) is a serial communication line for real time application. It is an on-vehicle multiplex communication line with high data communication speed and excellent malfunction detection ability. Many electronic control units are equipped onto a vehicle, and each control unit shares information and links with other control units during operation (not independent). In CAN communication, control units are connected with 2 communication lines (CAN-H and CAN-L) allowing a high rate of information transmission with less wiring. Each control unit transmits/receives data but selectively reads required data only.

### DTC Logic

INFOID:000000009752569

### DTC DETECTION LOGIC

DTC	Trouble diagnosis name	DTC detection condition	Possible causes
U1000	CAN Communication Line	When the ignition switch is ON, TCM cannot send the CAN communication signal continuously for 2 seconds or more.	Harness or connector (CAN communication line is open or shorted)

### DTC CONFIRMATION PROCEDURE

#### 1. PREPARATION BEFORE WORK

If another "DTC CONFIRMATION PROCEDURE" occurs just before, turn ignition switch OFF and wait for at least 10 seconds, then perform the next test.

>> GO TO 2.

#### 2. CHECK DTC DETECTION

##### With CONSULT

1. Start the engine and wait for at least 5 seconds.
2. Run engine for at least 2 consecutive seconds at idle speed.
3. Select "Self Diagnostic Results" in "TRANSMISSION".

Is "U1000" detected?

- YES >> Go to [TM-228, "Diagnosis Procedure"](#).  
NO >> INSPECTION END

### Diagnosis Procedure

INFOID:000000009752570

For the diagnosis procedure, refer to [LAN-15, "Trouble Diagnosis Flow Chart"](#).

# U1010 CONTROL UNIT (CAN)

< DTC/CIRCUIT DIAGNOSIS >

[CVT: RE0F10B]

## U1010 CONTROL UNIT (CAN)

### Description

INFOID:000000009752571

CAN (Controller Area Network) is a serial communication line for real time application. It is an on-vehicle multiplex communication line with high data communication speed and excellent malfunction detection ability. Many electronic control units are equipped onto a vehicle, and each control unit shares information and links with other control units during operation (not independent). In CAN communication, control units are connected with 2 communication lines (CAN-H and CAN-L) allowing a high rate of information transmission with less wiring. Each control unit transmits/receives data but selectively reads required data only.

### DTC Logic

INFOID:000000009752572

### DTC DETECTION LOGIC

DTC	Trouble diagnosis name	DTC detection condition	Possible causes
U1010	TCM Communication Malfunction	When detecting error during the initial diagnosis of CAN controller to TCM.	TCM

### DTC CONFIRMATION PROCEDURE

#### 1. PREPARATION BEFORE WORK

If another "DTC CONFIRMATION PROCEDURE" occurs just before, turn ignition switch OFF and wait for at least 10 seconds, then perform the next test.

>> GO TO 2.

#### 2. CHECK DTC DETECTION

##### With CONSULT

1. Start the engine.
2. Run engine for at least 6 consecutive seconds at idle speed.
3. Select "Self Diagnostic Results" in "TRANSMISSION".

##### With GST

Follow the procedure "With CONSULT".

Is "U1010" detected?

- YES >> Go to [TM-229. "Diagnosis Procedure"](#).  
NO >> INSPECTION END

### Diagnosis Procedure

INFOID:000000009752573

#### 1. CHECK INTERMITTENT INCIDENT

Refer to [GI-46. "Intermittent Incident"](#).

Is the inspection result normal?

- YES >> Replace the TCM. Refer to [TM-320. "Removal and Installation"](#).  
NO >> Repair or replace damaged parts.

# P0703 BRAKE SWITCH B

< DTC/CIRCUIT DIAGNOSIS >

[CVT: RE0F10B]

## P0703 BRAKE SWITCH B

### Description

INFOID:000000009752574

BCM detects ON/OFF state of the stop lamp switch and transmits the data to the CVT control unit via CAN communication by converting the data to a signal.

### DTC Logic

INFOID:000000009752575

### DTC DETECTION LOGIC

DTC	Trouble diagnosis name	DTC detection condition	Possible causes
P0703	Brake Switch B Circuit	<ul style="list-style-type: none"> <li>TCM detects malfunction in CAN communication between BCM.</li> <li>TCM detects a state that ON/OFF of stop lamp switch signal is not switched.</li> </ul>	<ul style="list-style-type: none"> <li>Harness or connectors</li> <li>(Stop lamp switch, and BCM circuit are open or shorted.)</li> <li>(CAN communication line is open or shorted.)</li> <li>Stop lamp switch</li> <li>BCM</li> </ul>

### DTC CONFIRMATION PROCEDURE

#### CAUTION:

**Always drive vehicle at a safe speed.**

#### 1. PREPARATION BEFORE WORK

If another "DTC CONFIRMATION PROCEDURE" occurs just before, turn ignition switch OFF and wait for at least 10 seconds, then perform the next test.

>> GO TO 2.

#### 2. CHECK DTC DETECTION

##### With CONSULT

- Start the engine.
- Select "Data Monitor" in "TRANSMISSION".
- Select "VEHICLE SPEED".
- Drive the vehicle.
- Maintain the following condition for 10 seconds or more.

VEHICLE SPEED : 30 km/h (19 MPH)

- Stop the vehicle.
- Select "Self Diagnostic Results" in "TRANSMISSION".

Is "P0703" detected?

- YES >> Go to [TM-230, "Diagnosis Procedure"](#).  
 NO >> INSPECTION END

### Diagnosis Procedure

INFOID:000000009752576

#### 1. CHECK STOP LAMP SWITCH CIRCUIT

- Turn ignition switch OFF.
- Disconnect stop lamp switch connector.
- Check voltage between stop lamp switch harness connector terminal and ground.

+		-	Voltage
Connector	Terminal		
E102	1	Ground	Battery voltage

Is the inspection result normal?

# P0703 BRAKE SWITCH B

[CVT: RE0F10B]

< DTC/CIRCUIT DIAGNOSIS >

- YES >> GO TO 2.  
NO >> GO TO 6.

## 2.CHECK CIRCUIT BETWEEN STOP LAMP SWITCH AND BCM (PART 1)

1. Disconnect BCM connector.
2. Check continuity between stop lamp switch harness connector terminal and BCM harness connector terminal.

Without intelligent key system

Stop lamp switch		BCM		Continuity
Connector	Terminal	Connector	Terminal	
E102	2	M65	9	Existed

With intelligent key system

Stop lamp switch		BCM		Continuity
Connector	Terminal	Connector	Terminal	
E102	2	M68	9	Existed

Is the inspection result normal?

- YES >> GO TO 3.  
NO >> Repair or replace damaged parts.

## 3.CHECK CIRCUIT BETWEEN STOP LAMP SWITCH AND BCM (PART 2)

Check short circuit in harness between stop lamp switch harness connector terminal 2 and BCM harness connector terminal 9.

Is the inspection result normal?

- YES >> GO TO 4.  
NO >> Repair or replace damaged parts.

## 4.CHECK INSTALLATION POSITION OF STOP LAMP SWITCH

Check stop lamp switch mounting position. Refer to [BR-7, "Inspection and Adjustment"](#).

Is the inspection result normal?

- YES >> GO TO 5.  
NO >> Adjust stop lamp switch mounting position.

## 5.CHECK STOP LAMP SWITCH

Check stop lamp switch. Refer to [TM-231, "Component Inspection \(Stop Lamp Switch\)"](#).

Is the inspection result normal?

- YES >> Check intermittent incident. Refer to [GI-46, "Intermittent Incident"](#).  
NO >> Repair or replace stop lamp switch.

## 6.DETECT MALFUNCTIONING ITEM

Check the following items:

- Open circuit or short circuit in harness between battery and stop lamp switch connector terminal 1. Refer to [PG-11, "Wiring Diagram - BATTERY POWER SUPPLY -"](#).
- Battery
- 10A fuse [No.38, located in fuse block (J/B)]. Refer to [PG-62, "Fuse, Connector and Terminal Arrangement"](#).

Is the inspection result normal?

- YES >> Check intermittent incident. Refer to [GI-46, "Intermittent Incident"](#).  
NO >> Repair or replace damaged parts.

## Component Inspection (Stop Lamp Switch)

INFOID:000000009752577

### 1.CHECK STOP LAMP SWITCH

Check continuity between stop lamp switch connector terminals.

## P0703 BRAKE SWITCH B

< DTC/CIRCUIT DIAGNOSIS >

[CVT: RE0F10B]

Stop lamp switch Terminal	Condition	Continuity
1 - 2	Depressed brake pedal	Existed
	Released brake pedal	Not existed

Is the inspection result normal?

YES >> INSPECTION END

NO >> Replace the stop lamp switch. Refer to [BR-18. "Exploded View"](#).



# P0705 TRANSMISSION RANGE SENSOR A

< DTC/CIRCUIT DIAGNOSIS >

[CVT: RE0F10B]

## P0705 TRANSMISSION RANGE SENSOR A

### DTC Logic

INFOID:000000009752578

### DTC DETECTION LOGIC

DTC	Trouble diagnosis name	DTC detection condition	Possible causes
P0705	Transmission Range Sensor A Circuit (PRNDL Input)	<ul style="list-style-type: none"> <li>Range signal is not input to TCM.</li> <li>2 or more position signals are input to TCM.</li> </ul>	<ul style="list-style-type: none"> <li>Harness or connectors (Transmission range switches circuit is open or shorted.)</li> <li>Transmission range switch</li> </ul>

### DTC CONFIRMATION PROCEDURE

#### CAUTION:

Always drive vehicle at a safe speed.

#### 1. PREPARATION BEFORE WORK

If another "DTC CONFIRMATION PROCEDURE" occurs just before, turn ignition switch OFF and wait for at least 10 seconds, then perform the next test.

>> GO TO 2.

#### 2. PREPARATION BEFORE WORK (PART 2)

Perform function check of combination meter. Refer to [MWI-20, "On Board Diagnosis Function"](#).

>> GO TO 3.

#### 3. PERFORM FUNCTION CHECK

#### NOTE:

DTC cannot be identified through this inspection.

- Turn ignition switch ON.
- Check that the shift position indicator on the combination meter is displayed correctly when the selector lever is shifted to each position ("P", "R", "N", "D").

Is the check result normal?

- YES >> Go to [TM-233, "Diagnosis Procedure"](#).  
 NO >> INSPECTION END

### Diagnosis Procedure

INFOID:000000009752579

#### 1. CHECK TRANSMISSION RANGE SWITCH POWER CIRCUIT

- Turn ignition switch OFF.
- Disconnect transmission range switch connector.
- Turn ignition switch ON.
- Check voltage between transmission range switch harness connector terminal and ground.

+		-	Condition	Voltage
Connector	Terminal			
F27	3	Ground	Ignition switch: ON	10 – 16 V
			Ignition switch: OFF	Approx. 0 V

Is the check result normal?

- YES >> GO TO 2.  
 NO >> GO TO 6.

#### 2. CHECK HARNESS BETWEEN TCM AND TRANSMISSION RANGE SWITCH (PART 1)

- Turn ignition switch OFF.

# P0705 TRANSMISSION RANGE SENSOR A

[CVT: RE0F10B]

## < DTC/CIRCUIT DIAGNOSIS >

2. Disconnect TCM connector.
3. Check continuity between TCM harness connector terminals and transmission range switch harness connector terminals.

TCM		Transmission range switch		Continuity
Connector	Terminal	Connector	Terminal	
F81	1	F27	5	Existed
	2		6	
	3		7	
	11		4	

### Is the check result normal?

YES >> GO TO 3.

NO >> Repair or replace damaged parts.

## 3. CHECK HARNESS BETWEEN TCM AND TRANSMISSION RANGE SWITCH (PART 2)

Check continuity between TCM harness connector terminals and ground.

TCM		—	Continuity
Connector	Terminal		
F81	1	Ground	Not existed
	2		
	3		
	11		

### Is the check result normal?

YES >> GO TO 4.

NO >> Repair or replace damaged parts.

## 4. CHECK TRANSMISSION RANGE SWITCH MOUNTING POSITION

1. Remove control cable from manual lever. Refer to [TM-310, "Exploded View"](#).
2. Check transmission range switch mounting position. Refer to [TM-318, "Inspection and Adjustment"](#).

### Is the check result normal?

YES >> GO TO 5.

NO >> Adjust transmission range switch mounting position.

## 5. CHECK TRANSMISSION RANGE SWITCH

1. Install control cable to manual lever. Refer to [TM-310, "Exploded View"](#).
2. Check transmission range switch. Refer to [TM-235, "Component Inspection \(Transmission Range Switch\)"](#).

### Is the check result normal?

YES >> Check intermittent incident. Refer to [GI-46, "Intermittent Incident"](#).

NO >> Replace transmission range switch.

## 6. CHECK HARNESS BETWEEN TRANSMISSION RANGE SWITCH AND IPDM E/R

1. Turn ignition switch OFF.
2. Disconnect IPDM E/R connector.
3. Check continuity between transmission range switch harness connector terminal and IPDM E/R harness connector terminal.

IPDM E/R		Transmission range switch		Continuity
Connector	Terminal	Connector	Terminal	
E15	57	F27	3	Existed

### Is the check result normal?

YES >> GO TO 7.

# P0705 TRANSMISSION RANGE SENSOR A

< DTC/CIRCUIT DIAGNOSIS >

[CVT: RE0F10B]

NO >> Repair or replace damaged parts.

## 7. DETECT MALFUNCTIONING ITEM

Check the following items:

- Open circuit or short circuit in harness between ignition switch and IPDM E/R. Refer to [PG-41, "Wiring Diagram - IGNITION POWER SUPPLY -"](#).
- Short circuit in harness between IPDM E/R harness connector terminal 57 and transmission range switch harness connector terminal 5.
- 10A fuse (No.55, IPDM E/R). Refer to [PG-64, "Fuse, Connector and Terminal Arrangement"](#).
- IPDM E/R

Is the check result normal?

YES >> Check intermittent incident. Refer to [GI-46, "Intermittent Incident"](#).

NO >> Repair or replace damaged parts.

## Component Inspection (Transmission Range Switch)

INFOID:000000009752580

## 1. CHECK TRANSMISSION RANGE SWITCH

Check continuity between transmission range switch connector terminals.

Transmission range switch Terminal	Condition	Continuity
1 – 2	Manual lever: "P" and "N" position	Existed
	Other than the above	Not existed
3 – 4	Manual lever: "P" position	Existed
	Other than the above	Not existed
3 – 5	Manual lever: "R" position	Existed
	Other than the above	Not existed
3 – 6	Manual lever: "N" position	Existed
	Other than the above	Not existed
3 – 7	Manual lever: "D" position	Existed
	Other than the above	Not existed

Is the inspection result normal?

YES >> INSPECTION END

NO >> Replace transmission range switch. Refer to [TM-318, "Removal and Installation"](#).

# P0710 TRANSMISSION FLUID TEMPERATURE SENSOR A

< DTC/CIRCUIT DIAGNOSIS >

[CVT: RE0F10B]

## P0710 TRANSMISSION FLUID TEMPERATURE SENSOR A

### DTC Logic

INFOID:000000009752581

### DTC DETECTION LOGIC

DTC	Trouble diagnosis name	DTC detection condition	Possible causes
P0710	Transmission Fluid Temperature Sensor A Circuit	<ul style="list-style-type: none"><li>Detected value from CVT fluid temperature sensor received by TCM is less than 20°C (68°F) for a certain length of time.</li><li>CVT Fluid temperature sensor value that TCM receives is more than 180°C (356°F).</li></ul>	<ul style="list-style-type: none"><li>Harness or connectors (Sensor circuit is open or shorted.)</li><li>CVT fluid temperature sensor</li></ul>
		A/T fluid temperature does not rise to the specified temperature after driving for a certain period of time with the TCM-received fluid temperature sensor value between -40°C (-40°F) and 20°C (68°F).	<ul style="list-style-type: none"><li>Harness or connectors (Sensor circuit is stuck.)</li><li>A/T fluid temperature sensor</li></ul>
		The following conditions are maintained for 5 minutes after the completion of engine diagnosis P0111, P0116, and P0196: <ul style="list-style-type: none"><li>A/T fluid temperature – Engine coolant temperature &gt; 53°C (127°F)</li><li>A/T fluid temperature – Engine coolant temperature &lt; -27°C (-16.6°F)</li></ul>	A/T fluid temperature sensor

### DTC CONFIRMATION PROCEDURE

#### CAUTION:

Always drive vehicle at a safe speed.

#### 1. PREPARATION BEFORE WORK (PART 1)

If another "DTC CONFIRMATION PROCEDURE" occurs just before, turn ignition switch OFF and wait for at least 10 seconds, then perform the next test.

>> GO TO 2.

#### 2. PREPARATION BEFORE WORK (PART 2)

##### Ⓜ With CONSULT

- Turn ignition switch ON.
- Select "Data Monitor" in "TRANSMISSION".
- Select "ATF TEMP SEN".

Is the value of "ATF TEMP SEN" within 2.03 – 0.16 V?

YES >> INSPECTION END

NO-1 ("ATF TEMP SEN" indicates 0.15 or less) >> Go to [TM-237. "Diagnosis Procedure"](#).

NO-2 ("ATF TEMP SEN" indicates 2.04 or more) >> GO TO 3.

#### 3. CHECK DTC DETECTION

##### Ⓜ With CONSULT

- Start the engine.
- Select "Data Monitor" in "TRANSMISSION".
- Select "RANGE", "ACC PEDAL OPEN" and "VEHICLE SPEED".
- Drive the vehicle.
- Maintain the following conditions for at least 14 minutes (Total).

RANGE : "D" position  
ACC PEDAL OPEN : 1.0/8 or more  
VEHICLE SPEED : 10 km/h (7 MPH) or more

- Stop the vehicle.
- Select "Self Diagnostic Results" in "TRANSMISSION".

# P0710 TRANSMISSION FLUID TEMPERATURE SENSOR A

< DTC/CIRCUIT DIAGNOSIS >

[CVT: RE0F10B]

## With GST

Follow the procedure "With CONSULT".

Is "P0710" detected?

- YES >> Go to [TM-237. "Diagnosis Procedure"](#).
- NO >> GO TO 4.

## 4. CHECK CVT FLUID TEMPERATURE SENSOR

1. Turn ignition switch OFF.
2. Disconnect CVT unit connector.
3. Check resistance between CVT unit connector terminals.

CVT unit		Condition	Resistance
Connector	Terminal		
F209	17 – 19	CVT fluid temperature: 20°C (68°F)	Approx. 6.83 – 6.29 kΩ
		CVT fluid temperature: 50°C (122°F)	Approx. 2.25 – 2.10 kΩ
		CVT fluid temperature: 80°C (176°F)	Approx. 0.90 – 0.85 kΩ

Is the inspection result normal?

- YES >> INSPECTION END
- NO >> There is a malfunction of the CVT fluid temperature sensor. Replace the control valve. Refer to [TM-322. "Removal and Installation"](#).

## Diagnosis Procedure

INFOID:000000009752582

## 1. CHECK CVT FLUID TEMPERATURE SENSOR

1. Turn ignition switch OFF.
2. Disconnect CVT unit connector.
3. Check resistance between CVT unit connector terminals.

CVT unit		Condition	Resistance
Connector	Terminal		
F209	17 – 19	CVT fluid temperature: 20°C (68°F)	Approx. 6.83 – 6.29 kΩ
		CVT fluid temperature: 50°C (122°F)	Approx. 2.25 – 2.10 kΩ
		CVT fluid temperature: 80°C (176°F)	Approx. 0.90 – 0.85 kΩ

Is the inspection result normal?

- YES >> GO TO 2.
- NO >> GO TO 4.

## 2. CHECK CIRCUIT BETWEEN TCM AND CVT UNIT (CVT FLUID TEMPERATURE SENSOR) (PART 1)

1. Disconnect the TCM connector.
2. Check continuity between TCM harness connector terminals and CVT unit harness connector terminals.

TCM		CVT unit		Continuity
Connector	Terminal	Connector	Terminal	
F81	13	F51	17	Existed
	25		19	

Is the inspection result normal?

- YES >> GO TO 3.
- NO >> Repair or replace damaged parts.

## 3. CHECK CIRCUIT BETWEEN TCM AND CVT UNIT (CVT FLUID TEMPERATURE SENSOR) (PART 2)

Check continuity between TCM harness connector terminals and ground.

# P0710 TRANSMISSION FLUID TEMPERATURE SENSOR A

< DTC/CIRCUIT DIAGNOSIS >

[CVT: RE0F10B]

TCM		Ground	Continuity
Connector	Terminal		
F81	13	Ground	Not existed
	25		

Is the inspection result normal?

YES >> Check intermittent incident. Refer to [GI-46, "Intermittent Incident"](#).

NO >> Repair or replace damaged parts.

## 4. CHECK TERMINAL CORD ASSEMBLY (PART 1)

1. Remove terminal cord assembly. Refer to [TM-322, "Exploded View"](#).
2. Check continuity between CVT unit harness connector terminals and control valve harness connector terminals.

CVT unit		Control valve		Continuity
Connector	Terminal	Connector	Terminal	
F209	17	F208	22	Existed
	19		21	

Is the inspection result normal?

YES >> GO TO 5.

NO >> Repair or replace damaged parts.

## 5. CHECK TERMINAL CORD ASSEMBLY (PART 2)

Check terminal cord assembly harness cladding for damage.

Is the inspection result normal?

YES >> GO TO 6.

NO >> Repair or replace damaged parts.

## 6. CHECK DTC (TCM)

### With CONSULT

1. Perform "DTC CONFIRMATION PROCEDURE". Refer to [TM-236, "DTC Logic"](#).
2. Select "Self Diagnostic Results" in "TRANSMISSION".

Is "P0710" detected?

YES-1 ("P0710" only)>>There is a malfunction of the CVT fluid temperature sensor. Replace the control valve. Refer to [TM-322, "Removal and Installation"](#).

YES-2 ("P0710" and other DTC)>>Replace the transaxle assembly. Refer to [TM-339, "2WD : Removal and Installation"](#) (2WD) or [TM-342, "AWD : Removal and Installation"](#) (AWD).

NO >> Check intermittent incident. Refer to [GI-46, "Intermittent Incident"](#).

# P0715 INPUT SPEED SENSOR A

< DTC/CIRCUIT DIAGNOSIS >

[CVT: RE0F10B]

## P0715 INPUT SPEED SENSOR A

### DTC Logic

INFOID:000000009752583

### DTC DETECTION LOGIC

DTC	Trouble diagnosis name	DTC detection condition	Possible causes
P0715	Input/Turbine Speed Sensor A Circuit	<ul style="list-style-type: none"> <li>Primary speed signal is not input to TCM</li> <li>Primary pulley speed sensor value is less than 150 rpm while secondary pulley speed is 500 rpm or more</li> </ul>	<ul style="list-style-type: none"> <li>Harness or connectors (Sensor circuit is open or shorted.)</li> <li>Primary speed sensor</li> </ul>

### DTC CONFIRMATION PROCEDURE

#### CAUTION:

Always drive vehicle at a safe speed.

#### 1. PREPARATION BEFORE WORK

If another "DTC CONFIRMATION PROCEDURE" occurs just before, turn ignition switch OFF and wait for at least 10 seconds, then perform the next test.

>> GO TO 2.

#### 2. CHECK DTC DETECTION

##### With CONSULT

- Start the engine.
- Select "Data Monitor" in "TRANSMISSION".
- Select "SEC SPEED" and "VEHICLE SPEED".
- Drive the vehicle.
- Maintain the following conditions for 5 seconds or more.

SEC SPEED	: 500 rpm or more
VEHICLE SPEED	: 10 km/h (7 MPH) or more

- Stop the vehicle.
- Select "Self Diagnostic Results" in "TRANSMISSION".

##### With GST

Follow the procedure "With CONSULT".

Is "P0715" detected?

- YES >> Go to [TM-239, "Diagnosis Procedure"](#).
- NO >> INSPECTION END

### Diagnosis Procedure

INFOID:000000009752584

#### 1. CHECK PRIMARY SPEED SENSOR POWER SUPPLY CIRCUIT

- Turn ignition switch OFF.
- Disconnect primary speed sensor connector.
- Turn ignition switch ON.
- Check voltage between primary speed sensor harness connector terminal and ground.

+		-	Voltage
Connector	Terminal		
F55	3	Ground	10 V – 16 V

Is the inspection result normal?

- YES >> GO TO 2.
- NO >> GO TO 5.

# P0715 INPUT SPEED SENSOR A

[CVT: RE0F10B]

< DTC/CIRCUIT DIAGNOSIS >

## 2. CHECK TCM INPUT SIGNAL

1. Turn ignition switch OFF.
2. Connect primary speed sensor connector.
3. Lift up the vehicle.
4. Start the engine.
5. Check frequency of primary speed sensor.

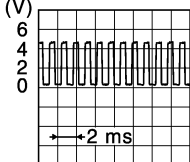
TCM			Condition	Frequency (Approx.)
Connector	+	-		
	Terminal			
F81	33	25	<ul style="list-style-type: none"> <li>• Selector lever: "M1" position</li> <li>• Vehicle speed: 20 km/h (12 MPH)</li> </ul>	<p>720 Hz</p>  <p>JPDIA0819ZZ</p>

Is the inspection result normal?

- YES >> Check intermittent incident. Refer to [GI-46. "Intermittent Incident"](#).  
 NO >> GO TO 3.

## 3. CHECK CIRCUIT BETWEEN TCM AND PRIMARY SPEED SENSOR (PART 1)

1. Turn ignition switch OFF.
2. Disconnect TCM connector and primary speed sensor connector.
3. Check continuity between TCM harness connector terminals and primary speed sensor harness connector terminals.

TCM		Primary speed sensor		Continuity
Connector	Terminal	Connector	Terminal	
F81	25	F55	1	Existed
	33		2	

Is the inspection result normal?

- YES >> GO TO 4.  
 NO >> Repair or replace damaged parts.

## 4. CHECK CIRCUIT BETWEEN TCM AND PRIMARY SPEED SENSOR (PART 2)

Check continuity between TCM harness connector terminals and ground.

TCM		—	Continuity
Connector	Terminal		
F81	25	Ground	Not existed
	33		

Is the inspection result normal?

- YES >> Replace primary speed sensor. Refer to [TM-329. "Removal and Installation"](#).  
 NO >> Repair or replace damaged parts.

## 5. CHECK CIRCUIT BETWEEN PRIMARY SPEED SENSOR AND IPDM E/R

1. Turn ignition switch OFF.
2. Disconnect IPDM E/R connector.
3. Check continuity between primary speed sensor harness connector terminal and IPDM E/R harness connector terminal.



# P0715 INPUT SPEED SENSOR A

< DTC/CIRCUIT DIAGNOSIS >

[CVT: RE0F10B]

Primary speed sensor		IPDM E/R		Continuity
Connector	Terminal	Connector	Terminal	
F55	3	E15	57	Existed

Is the inspection result normal?

YES >> GO TO 6.

NO >> Repair or replace damaged parts.

## 6. DETECT MALFUNCTIONING ITEM

Check the following items:

- Open circuit or short circuit in harness between ignition switch and IPDM E/R. Refer to [PG-41. "Wiring Diagram - IGNITION POWER SUPPLY -"](#).
- Short circuit in harness between IPDM E/R harness connector terminal 57 and primary speed sensor harness connector terminal 3.
- 10A fuse (No.55, located in IPDM E/R). Refer to [PG-64. "Fuse, Connector and Terminal Arrangement"](#).
- IPDM E/R

Is the check result normal?

YES >> Check intermittent incident. Refer to [GI-46. "Intermittent Incident"](#).

NO >> Repair or replace damaged parts.

A  
B  
C  
TM  
E  
F  
G  
H  
I  
J  
K  
L  
M  
N  
O  
P

# P0720 OUTPUT SPEED SENSOR

< DTC/CIRCUIT DIAGNOSIS >

[CVT: RE0F10B]

## P0720 OUTPUT SPEED SENSOR

### DTC Logic

INFOID:000000009752585

### DTC DETECTION LOGIC

DTC	Trouble diagnosis name	DTC detection condition	Possible causes
P0720	Output Speed Sensor Circuit	<ul style="list-style-type: none"> <li>Secondary speed sensor signal is not input to TCM.</li> <li>Secondary pulley speed sensor value is less than 150 rpm while primary pulley speed is 1,000 rpm or more.</li> </ul>	<ul style="list-style-type: none"> <li>Harness or connectors (Sensor circuit is open or shorted.)</li> <li>Output speed sensor</li> </ul>

### DTC CONFIRMATION PROCEDURE

#### CAUTION:

Always drive vehicle at a safe speed.

#### 1. PREPARATION BEFORE WORK

If another "DTC CONFIRMATION PROCEDURE" occurs just before, turn ignition switch OFF and wait for at least 10 seconds, then perform the next test.

>> GO TO 2.

#### 2. CHECK DTC DETECTION

##### With CONSULT

- Start the engine.
- Select "Data Monitor" in "TRANSMISSION".
- Select "PRI SPEED" and "VEHICLE SPEED".
- Drive the vehicle.
- Maintain the following conditions for 5 seconds or more.

PRI SPEED	: 1,000 rpm or more
VEHICLE SPEED	: 10 km/h (7 MPH) or more

- Stop the vehicle.
- Select "Self Diagnostic Results" in "TRANSMISSION".

##### With GST

Follow the procedure "With CONSULT".

Is "P0720" detected?

- YES >> Go to [TM-242, "Diagnosis Procedure"](#).
- NO >> INSPECTION END

### Diagnosis Procedure

INFOID:000000009752586

#### 1. CHECK SECONDARY SPEED SENSOR POWER SUPPLY CIRCUIT

- Turn ignition switch OFF.
- Disconnect secondary speed sensor connector.
- Turn ignition switch ON.
- Check voltage between secondary speed sensor harness connector terminal and ground.

+		-	Voltage
Connector	Terminal		
F19	3	Ground	10 V – 16 V

Is the inspection result normal?

- YES >> GO TO 2.
- NO >> GO TO 5.

# P0720 OUTPUT SPEED SENSOR

< DTC/CIRCUIT DIAGNOSIS >

[CVT: RE0F10B]

## 2. CHECK TCM INPUT SIGNAL

1. Turn ignition switch OFF.
2. Connect secondary speed sensor connector.
3. Lift up the vehicle.
4. Start the engine.
5. Check frequency of secondary speed sensor.

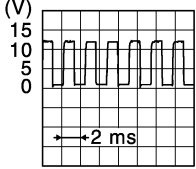
TCM			Condition	Frequency (Approx.)
Connector	+	-		
	Terminal			
F81	34	25	<ul style="list-style-type: none"> <li>• Selector lever: "M<sup>1</sup>" position</li> <li>• Vehicle speed: 20 km/h (12 MPH)</li> </ul>	<p>480 Hz</p>  <p>JPDIA0901ZZ</p>

Is the inspection result normal?

- YES >> Check intermittent incident. Refer to [GI-46, "Intermittent Incident"](#).  
 NO >> GO TO 3.

## 3. CHECK CIRCUIT BETWEEN TCM AND SECONDARY SPEED SENSOR (PART 1)

1. Turn ignition switch OFF.
2. Disconnect TCM connector and secondary speed sensor connector.
3. Check continuity between TCM harness connector terminals and secondary speed sensor harness connector terminals.

TCM		Secondary speed sensor		Continuity
Connector	Terminal	Connector	Terminal	
F81	25	F19	1	Existed
	34		2	

Is the inspection result normal?

- YES >> GO TO 4.  
 NO >> Repair or replace damaged parts.

## 4. CHECK CIRCUIT BETWEEN TCM AND SECONDARY SPEED SENSOR (PART 2)

Check continuity between TCM harness connector terminals and ground.

TCM		—	Continuity
Connector	Terminal		
F81	25	Ground	Not existed
	34		

Is the inspection result normal?

- YES >> Replace secondary speed sensor. Refer to [TM-329, "Removal and Installation"](#).  
 NO >> Repair or replace damaged parts.

## 5. CHECK CIRCUIT BETWEEN SECONDARY SPEED SENSOR AND IPDM E/R

1. Turn ignition switch OFF.
2. Disconnect IPDM E/R connector.
3. Check continuity between secondary speed sensor harness connector terminal and IPDM E/R harness connector terminal.

## P0720 OUTPUT SPEED SENSOR

< DTC/CIRCUIT DIAGNOSIS >

[CVT: RE0F10B]

Secondary speed sensor		IPDM E/R		Continuity
Connector	Terminal	Connector	Terminal	
F19	3	E15	57	Existed

Is the inspection result normal?

YES >> GO TO 6.

NO >> Repair or replace damaged parts.

### 6. DETECT MALFUNCTIONING ITEM

Check the following items:

- Open circuit or short circuit in harness between ignition switch and IPDM E/R. Refer to [PG-41. "Wiring Diagram - IGNITION POWER SUPPLY -"](#).
- Short circuit in harness between IPDM E/R harness connector terminal 57 and secondary speed sensor harness connector terminal 3.
- 10A fuse (No.55, located in IPDM E/R). Refer to [PG-64. "Fuse, Connector and Terminal Arrangement"](#).
- IPDM E/R

Is the check result normal?

YES >> Check intermittent incident. Refer to [GI-46. "Intermittent Incident"](#).

NO >> Repair or replace damaged parts.

# P0725 ENGINE SPEED

< DTC/CIRCUIT DIAGNOSIS >

[CVT: RE0F10B]

## P0725 ENGINE SPEED

### Description

INFOID:000000009752587

The engine speed signal is transmitted from ECM to TCM by CAN communication line.

### DTC Logic

INFOID:000000009752588

### DTC DETECTION LOGIC

DTC	Trouble diagnosis name	DTC detection condition	Possible causes
P0725	Engine Speed Input Circuit	<ul style="list-style-type: none"> <li>TCM detects a malfunction of CAN communication between ECM.</li> <li>A DTC is set if the engine speed (CAN communication) is less than 450 rpm when the primary pulley speed is 1,000 rpm or more.</li> </ul>	<ul style="list-style-type: none"> <li>Harness or connectors (The ECM to the TCM circuit is open or shorted.)</li> <li>ECM</li> </ul>

### DTC CONFIRMATION PROCEDURE

#### CAUTION:

Always drive vehicle at a safe speed.

#### 1. PREPARATION BEFORE WORK

If another "DTC CONFIRMATION PROCEDURE" occurs just before, turn ignition switch OFF and wait for at least 10 seconds, then perform the next test.

>> GO TO 2.

#### 2. CHECK DTC DETECTION

##### With CONSULT

- Start the engine.
- Select "Data Monitor" in "TRANSMISSION".
- Select "PRI SPEED".
- Drive the vehicle.
- Maintain the following condition for 10 seconds or more.

PRI SPEED : 1,000 rpm or more

- Stop the vehicle.
- Select "Self Diagnostic Results" in "TRANSMISSION".

##### Is "P0725" detected?

- YES >> Go to [TM-245, "Diagnosis Procedure"](#).  
 NO >> INSPECTION END

### Diagnosis Procedure

INFOID:000000009752589

#### 1. CHECK DTC (ECM)

##### With CONSULT

- Turn ignition switch ON.
- Select "Self Diagnostic Results" in "ENGINE".

##### Is any DTC detected?

- YES >> Check DTC detected item. Refer to [EC-101, "DTC Index"](#).  
 NO >> Check intermittent incident. Refer to [GI-46, "Intermittent Incident"](#).

# P0740 TORQUE CONVERTER

< DTC/CIRCUIT DIAGNOSIS >

[CVT: RE0F10B]

## P0740 TORQUE CONVERTER

### DTC Logic

INFOID:000000009752590

### DTC DETECTION LOGIC

DTC	Trouble diagnosis name	DTC detection condition	Possible causes
P0740	Torque Converter Clutch Circuit/Open	<ul style="list-style-type: none"><li>• TCM monitor voltage value for torque converter clutch solenoid valve is less than 70% of target voltage value for torque converter clutch solenoid valve.</li><li>• There is a large difference between TCM monitor current command value for torque converter clutch solenoid valve and current monitor value for torque converter clutch solenoid valve.</li></ul>	<ul style="list-style-type: none"><li>• Harness or connectors (Solenoid circuit is open or shorted.)</li><li>• Torque converter clutch solenoid valve</li></ul>

### DTC CONFIRMATION PROCEDURE

#### CAUTION:

**Always drive vehicle at a safe speed.**

#### 1. PREPARATION BEFORE WORK (PART 1)

If another "DTC CONFIRMATION PROCEDURE" occurs just before, turn ignition switch OFF and wait for at least 10 seconds, then perform the next test.

>> GO TO 2.

#### 2. PREPARATION BEFORE WORK (PART 2)

##### With CONSULT

1. Start the engine.
2. Select "Data Monitor" in "TRANSMISSION".
3. Select "ATF TEMP SEN".

Is the value of "ATF TEMP SEN" 2.17 V or less?

YES >> GO TO 3.

- NO >> 1. Warm the transaxle.  
2. GO TO 3.

#### 3. CHECK DTC DETECTION

##### With CONSULT

1. Start the engine.
2. Select "Data Monitor" in "TRANSMISSION".
3. Select "VEHICLE SPEED".
4. Drive the vehicle.
5. Maintain the following condition for 5 seconds or more.

VEHICLE SPEED : 40 km/h (25 MPH) or more

6. Stop the vehicle.
7. Select "Self Diagnostic Results" in "TRANSMISSION".

##### With GST

Follow the procedure "With CONSULT".

Is "P0740" detected?

YES >> Go to [TM-246, "Diagnosis Procedure"](#).

NO >> INSPECTION END

### Diagnosis Procedure

INFOID:000000009752591

#### 1. CHECK TORQUE CONVERTER CLUTCH SOLENOID VALVE

1. Turn ignition switch OFF.

# P0740 TORQUE CONVERTER

[CVT: RE0F10B]

## < DTC/CIRCUIT DIAGNOSIS >

2. Disconnect CVT unit connector.
3. Check continuity between CVT unit harness connector terminal and ground.

CVT unit		Ground	Condition	Resistance
Connector	Terminal			
F209	12	Ground	CVT fluid temperature: 20°C (68°F)	Approx. 5.60 – 6.60 Ω
			CVT fluid temperature: 50°C (122°F)	Approx. 6.76 – 6.87 Ω
			CVT fluid temperature: 80°C (176°F)	Approx. 7.47 – 7.59 Ω

Is the inspection result normal?

- YES >> GO TO 2.  
NO >> GO TO 4.

## 2. CHECK CIRCUIT BETWEEN TCM AND CVT UNIT (TORQUE CONVERTER CLUTCH SOLENOID VALVE) (PART 1)

1. Disconnect TCM harness connector.
2. Check continuity between TCM harness connector terminal and CVT unit harness connector terminal.

TCM		CVT unit		Continuity
Connector	Terminal	Connector	Terminal	
F81	38	F51	12	Existed

Is the inspection result normal?

- YES >> GO TO 3.  
NO >> Repair or replace damaged parts.

## 3. CHECK CIRCUIT BETWEEN TCM AND CVT UNIT (TORQUE CONVERTER CLUTCH SOLENOID VALVE) (PART 2)

Check continuity between TCM harness connector terminal and ground.

TCM		Ground	Continuity
Connector	Terminal		
F81	38	Ground	Not existed

Is the inspection result normal?

- YES >> Check intermittent incident. Refer to [GI-46, "Intermittent Incident"](#).  
NO >> Repair or replace damaged parts.

## 4. CHECK TERMINAL CORD ASSEMBLY (PART 1)

1. Remove terminal cord assembly. Refer to [TM-322, "Exploded View"](#).
2. Check continuity between CVT unit harness connector terminals and control valve harness connector terminals.

CVT unit		Control valve		Continuity
Connector	Terminal	Connector	Terminal	
F209	12	F208	10	Existed

Is the inspection result normal?

- YES >> GO TO 5.  
NO >> Repair or replace damaged parts.

## 5. CHECK TERMINAL CORD ASSEMBLY (PART 2)

Check terminal cord assembly harness cladding for damage.

Is the inspection result normal?

- YES >> GO TO 6.  
NO >> Repair or replace damaged parts.

## P0740 TORQUE CONVERTER

< DTC/CIRCUIT DIAGNOSIS >

[CVT: RE0F10B]

### 6. CHECK DTC (TCM)

#### With CONSULT

1. Perform "DTC CONFIRMATION PROCEDURE". Refer to [TM-246, "DTC Logic"](#).
2. Select "Self Diagnostic Results" in "TRANSMISSION".

#### Is "P0740" detected?

YES-1 (Only "P0740" is detected)>>There is a malfunction of the torque converter clutch solenoid valve.

Replace the control valve. Refer to [TM-322, "Removal and Installation"](#).

YES-2 ("P0740" and other than "P0740" are detected)>>Replace the transaxle assembly. Refer to [TM-339, "2WD : Removal and Installation"](#) (2WD) or [TM-342, "AWD : Removal and Installation"](#) (AWD).

NO >> Check intermittent incident. Refer to [GI-46, "Intermittent Incident"](#).



# P0744 TORQUE CONVERTER

< DTC/CIRCUIT DIAGNOSIS >

[CVT: RE0F10B]

## P0744 TORQUE CONVERTER

### Description

INFOID:000000009752592

This malfunction is detected when the torque converter clutch does not lock-up as instructed by the TCM. This is not only caused by electrical malfunction (circuits open or shorted), but also by mechanical malfunction such as control valve sticking, improper solenoid valve operation, etc.

### DTC Logic

INFOID:000000009752593

### DTC DETECTION LOGIC

DTC	Trouble diagnosis name	DTC detection condition	Possible causes
P0744	Torque Converter Clutch Circuit Intermittent	Torque converter slip speed is more than a certain value (40 rpm + Vehicle speed × 0.8) while TCM is in lock-up command state	<ul style="list-style-type: none"><li>Hydraulic control circuit</li><li>Torque converter clutch solenoid valve</li><li>Lock-up select solenoid valve</li></ul>

### DTC CONFIRMATION PROCEDURE

#### CAUTION:

Always drive vehicle at a safe speed.

#### 1. PREPARATION BEFORE WORK

If another "DTC CONFIRMATION PROCEDURE" occurs just before, turn ignition switch OFF and wait for at least 10 seconds, then perform the next test.

>> GO TO 2.

#### 2. CHECK DTC DETECTION

##### With CONSULT

- Start the engine.
- Select "Data Monitor" in "TRANSMISSION".
- Select "RANGE", "ATF TEMP SEN", "ACC PEDAL OPEN" and "VEHICLE SPEED".
- Drive the vehicle.
- Maintain the following condition for 30 seconds or more.

RANGE	: D position
ATF TEMP SEN	: 2.03 V or less
ACC PEDAL OPEN	: 0.0/8 – 1.0/8
VEHICLE SPEED	: 40 km/h (25 MPH)

- Stop the vehicle.
- Select "Self Diagnostic Results" in "TRANSMISSION".

##### With GST

Follow the procedure "With CONSULT".

Is "P0744" detected?

- YES >> Go to [TM-249, "Diagnosis Procedure"](#).  
NO >> INSPECTION END

### Diagnosis Procedure

INFOID:000000009752594

#### 1. CHECK LINE PRESSURE

Perform line pressure test. Refer to [TM-221, "Inspection and Judgment"](#).

Is the inspection result normal?

- YES >> GO TO 2.  
NO >> Repair or replace damaged parts. Refer to [TM-221, "Inspection and Judgment"](#).

#### 2. CHECK TORQUE CONVERTER CLUTCH SOLENOID VALVE

Check torque converter clutch solenoid valve. Refer to [TM-246, "DTC Logic"](#).

## P0744 TORQUE CONVERTER

[CVT: RE0F10B]

< DTC/CIRCUIT DIAGNOSIS >

Is the inspection result normal?

- YES >> GO TO 3.
- NO >> GO TO 6.

### 3.CHECK LOCK-UP SELECT SOLENOID VALVE

Check lock-up select solenoid valve. Refer to [TM-282, "DTC Logic"](#).

Is the inspection result normal?

- YES >> GO TO 4.
- NO >> Repair or replace damaged parts.

### 4.CHECK PRIMARY SPEED SENSOR SYSTEM

Check primary speed sensor system. Refer to [TM-239, "DTC Logic"](#).

Is the inspection result normal?

- YES >> GO TO 5.
- NO >> Repair or replace damaged parts.

### 5.CHECK SECONDARY SPEED SENSOR SYSTEM

Check secondary speed sensor system. Refer to [TM-242, "DTC Logic"](#).

Is the inspection result normal?

- YES >> GO TO 6.
- NO >> Repair or replace damaged parts.

### 6.CHECK DTC (TCM)

#### With CONSULT

1. Perform "DTC CONFIRMATION PROCEDURE". Refer to [TM-249, "DTC Logic"](#).
2. Select "Self Diagnostic Results" in "TRANSMISSION".

Is "P0744" detected?

- YES-1 (Only "P0744" is detected)>>There is a malfunction of the torque converter clutch solenoid valve. Replace the control valve. Refer to [TM-322, "Removal and Installation"](#).
- YES-2 ("P0744" and other than "P0744" are detected)>>Replace the transaxle assembly. Refer to [TM-339, "2WD : Removal and Installation"](#) (2WD) or [TM-342, "AWD : Removal and Installation"](#) (AWD).
- NO >> Check intermittent incident. Refer to [GI-46, "Intermittent Incident"](#).

# P0745 PRESSURE CONTROL SOLENOID A

< DTC/CIRCUIT DIAGNOSIS >

[CVT: RE0F10B]

## P0745 PRESSURE CONTROL SOLENOID A

### DTC Logic

INFOID:000000009752595

### DTC DETECTION LOGIC

DTC	Trouble diagnosis name	DTC detection condition	Possible causes
P0745	Pressure Control Solenoid A	<ul style="list-style-type: none"> <li>TCM monitor voltage value for torque converter clutch solenoid valve is less than 70% of target voltage value for torque converter clutch solenoid valve.</li> <li>There is a large difference between TCM current monitor command value for line pressure solenoid valve and current monitor value for line pressure solenoid valve.</li> </ul>	<ul style="list-style-type: none"> <li>Harness or connectors (Solenoid circuit is open or shorted.)</li> <li>Line pressure solenoid valve</li> </ul>

### DTC CONFIRMATION PROCEDURE

#### CAUTION:

Always drive vehicle at a safe speed.

#### 1. PREPARATION BEFORE WORK

If another "DTC CONFIRMATION PROCEDURE" occurs just before, turn ignition switch OFF and wait for at least 10 seconds, then perform the next test.

>> GO TO 2.

#### 2. CHECK DTC DETECTION

##### With CONSULT

- Start the engine.
- Drive the vehicle for 10 seconds or more.
- Stop the vehicle.
- Select "Self Diagnostic Results" in "TRANSMISSION".

##### With GST

Follow the procedure "With CONSULT".

Is "P0745" detected?

YES >> Go to [TM-251, "Diagnosis Procedure"](#).

NO >> INSPECTION END

### Diagnosis Procedure

INFOID:000000009752596

#### 1. CHECK LINE PRESSURE SOLENOID VALVE

- Turn ignition switch OFF.
- Disconnect CVT unit connector.
- Check resistance between CVT unit connector terminal and ground.

CVT unit		Ground	Condition	Resistance
Connector	Terminal			
F209	2	Ground	CVT fluid temperature: 20°C (68°F)	Approx. 5.60 – 6.60 Ω
			CVT fluid temperature: 50°C (122°F)	Approx. 6.76 – 6.87 Ω
			CVT fluid temperature: 80°C (176°F)	Approx. 7.47 – 7.59 Ω

Is the inspection result normal?

YES >> GO TO 2.

NO >> GO TO 4.

#### 2. CHECK CIRCUIT BETWEEN TCM AND LINE PRESSURE SOLENOID VALVE (PART 1)

- Disconnect TCM connector.
- Check continuity between TCM harness connector terminal and CVT unit harness connector terminal.

# P0745 PRESSURE CONTROL SOLENOID A

< DTC/CIRCUIT DIAGNOSIS >

[CVT: RE0F10B]

TCM		CVT unit		Continuity
Connector	Terminal	Connector	Terminal	
F81	40	F51	2	Existed

Is the inspection result normal?

YES >> GO TO 3.

NO >> Repair or replace damaged parts.

## 3. CHECK CIRCUIT BETWEEN TCM AND LINE PRESSURE SOLENOID VALVE (PART 2)

Check continuity between TCM harness connector terminal and ground.

TCM		Ground	Continuity
Connector	Terminal		
F81	40	Ground	Not existed

Is the inspection result normal?

YES >> Check intermittent incident. Refer to [GI-46, "Intermittent Incident"](#).

NO >> Repair or replace damaged parts.

## 4. CHECK TERMINAL CORD ASSEMBLY (PART 1)

1. Remove terminal cord assembly. Refer to [TM-322, "Exploded View"](#).

2. Check continuity between CVT unit harness connector terminal and control valve harness connector terminal.

CVT unit		Control valve		Continuity
Connector	Terminal	Connector	Terminal	
F209	2	F208	8	Existed

Is the inspection result normal?

YES >> GO TO 5.

NO >> Repair or replace damaged parts.

## 5. CHECK TERMINAL CORD ASSEMBLY (PART 2)

Check terminal cord assembly harness cladding for damage.

Is the inspection result normal?

YES >> Replace the transaxle assembly. Refer to [TM-339, "2WD : Removal and Installation"](#) (2WD) or [TM-342, "AWD : Removal and Installation"](#) (AWD).

NO >> Repair or replace damaged parts.

# P0746 PRESSURE CONTROL SOLENOID A

< DTC/CIRCUIT DIAGNOSIS >

[CVT: RE0F10B]

## P0746 PRESSURE CONTROL SOLENOID A

### Description

INFOID:000000009752597

The line pressure solenoid valve regulates the oil pump discharge pressure to suit the driving condition in response to a signal sent from the TCM.

### DTC Logic

INFOID:000000009752598

### DTC DETECTION LOGIC

DTC	Trouble diagnosis name	DTC detection condition	Possible causes
P0746	Pressure Control Solenoid A Performance/Stuck Off	TCM detects a state that gear ratio is more than 2.7	<ul style="list-style-type: none"><li>Line pressure solenoid fluid circuit</li><li>Line pressure solenoid valve</li><li>Primary speed sensor</li><li>Secondary speed sensor</li></ul>

### DTC CONFIRMATION PROCEDURE

#### CAUTION:

Always drive vehicle at a safe speed.

#### 1. PREPARATION BEFORE WORK

If another "DTC CONFIRMATION PROCEDURE" occurs just before, turn ignition switch OFF and wait for at least 10 seconds, then perform the next test.

>> GO TO 2.

#### 2. CHECK DTC DETECTION

##### With CONSULT

- Start the engine.
- Select "Data Monitor" in "TRANSMISSION".
- Select "ENG SPEED SIG", "PRI SPEED" and "VEHICLE SPEED".
- Drive the vehicle.
- Maintain the following condition for 1 second or more.

ENG SPEED SIG	: 600 rpm or more
PRI SPEED	: 500 rpm or more
VEHICLE SPEED	: 10 km/h (7 MPH) or more

- Stop the vehicle.
- Select "Self Diagnostic Results" in "TRANSMISSION".

##### With GST

Follow the procedure "With CONSULT".

Is "P0746" detected?

- YES >> Go to [TM-253, "Diagnosis Procedure"](#).  
NO >> INSPECTION END

### Diagnosis Procedure

INFOID:000000009752599

#### 1. CHECK LINE PRESSURE

Perform line pressure test. Refer to [TM-221, "Inspection and Judgment"](#).

Is the inspection result normal?

- YES >> GO TO 2.  
NO >> Repair or replace damaged parts. Refer to [TM-221, "Inspection and Judgment"](#).

#### 2. CHECK LINE PRESSURE SOLENOID VALVE

Check line pressure solenoid valve. Refer to [TM-251, "DTC Logic"](#).

Is the inspection result normal?

## P0746 PRESSURE CONTROL SOLENOID A

< DTC/CIRCUIT DIAGNOSIS >

[CVT: RE0F10B]

- YES >> GO TO 3.  
NO >> Repair or replace damaged parts.

### 3.CHECK PRIMARY SPEED SENSOR SYSTEM

Check primary speed sensor system. Refer to [TM-239, "DTC Logic"](#).

Is the inspection result normal?

- YES >> GO TO 4.  
NO >> Repair or replace damaged parts.

### 4.CHECK SECONDARY SPEED SENSOR SYSTEM

Check secondary speed sensor system. Refer to [TM-242, "DTC Logic"](#).

Is the inspection result normal?

- YES >> GO TO 5.  
NO >> Repair or replace damaged parts.

### 5.CHECK INTERMITTENT INCIDENT

Refer to [GI-46, "Intermittent Incident"](#).

Is the inspection result normal?

- YES >> Replace transaxle assembly. Refer to [TM-339, "2WD : Removal and Installation"](#) (2WD) or [TM-342, "AWD : Removal and Installation"](#) (AWD).  
NO >> Repair or replace damaged parts.

# P0776 PRESSURE CONTROL SOLENOID B

< DTC/CIRCUIT DIAGNOSIS >

[CVT: RE0F10B]

## P0776 PRESSURE CONTROL SOLENOID B

### Description

INFOID:000000009752600

The secondary pressure solenoid valve regulates the secondary pressure to suit the driving condition in response to a signal sent from the TCM.

### DTC Logic

INFOID:000000009752601

### DTC DETECTION LOGIC

DTC	Trouble diagnosis name	DTC detection condition	Possible causes
P0776	Pressure Control Solenoid B Performance/Stuck Off	Difference of secondary pressure target value of TCM and secondary pressure actual value is more than 1.2 MPa	<ul style="list-style-type: none"><li>Secondary pressure solenoid valve</li><li>Secondary pressure sensor</li><li>Secondary pressure solenoid valve oil circuit</li><li>Line pressure solenoid valve oil circuit</li></ul>

### DTC CONFIRMATION PROCEDURE

#### CAUTION:

**Always drive vehicle at a safe speed.**

#### 1. PREPARATION BEFORE WORK

If another "DTC CONFIRMATION PROCEDURE" occurs just before, turn ignition switch OFF and wait for at least 10 seconds, then perform the next test.

>> GO TO 2.

#### 2. CHECK DTC DETECTION

##### With CONSULT

- Start the engine.
- Select "Data Monitor" in "TRANSMISSION".
- Select "RANGE", "VIGN SEN", "ATF TEMP SEN", "ACC PEDAL OPEN" and "VEHICLE SPEED".
- Drive the vehicle.
- Maintain the following condition for 5 seconds or more.

RANGE	: "D" position
VING SEN	: 10 V or more
ATF TEMP SEN	: 2.03 – 0.16 V
ACC PEDAL OPEN	: 1.0/8 or more
VEHICLE SPEED	: 10 km/h (7 MPH) or more

- Stop the vehicle.
- Select "Self Diagnostic Results" in "TRANSMISSION".

##### With GST

Follow the procedure "With CONSULT".

#### Is "P0776" detected?

- YES >> Go to [TM-255, "Diagnosis Procedure"](#).  
NO >> INSPECTION END

### Diagnosis Procedure

INFOID:000000009752602

#### 1. CHECK LINE PRESSURE

Perform line pressure test. Refer to [TM-221, "Inspection and Judgment"](#).

#### Is the inspection result normal?

- YES >> GO TO 2.  
NO >> Repair or replace damaged parts. Refer to [TM-221, "Inspection and Judgment"](#).

#### 2. CHECK SECONDARY PRESSURE SOLENOID VALVE

## P0776 PRESSURE CONTROL SOLENOID B

< DTC/CIRCUIT DIAGNOSIS >

[CVT: RE0F10B]

---

Check secondary pressure solenoid valve. Refer to [TM-257, "DTC Logic"](#).

Is the inspection result normal?

YES >> GO TO 3.

NO >> Repair or replace damaged parts.

### 3.CHECK SECONDARY PRESSURE SENSOR SYSTEM

---

Check secondary pressure sensor system. Refer to [TM-265, "DTC Logic"](#).

Is the inspection result normal?

YES >> GO TO 4.

NO >> Repair or replace damaged parts.

### 4.CHECK INTERMITTENT INCIDENTE

---

Refer to [GI-46, "Intermittent Incident"](#).

Is the inspection result normal?

YES >> Replace transaxle assembly. Refer to [TM-339, "2WD : Removal and Installation"](#) (2WD) or [TM-342, "AWD : Removal and Installation"](#) (AWD)

NO >> Repair or replace damaged parts.



# P0778 PRESSURE CONTROL SOLENOID B

< DTC/CIRCUIT DIAGNOSIS >

[CVT: RE0F10B]

## P0778 PRESSURE CONTROL SOLENOID B

### DTC Logic

INFOID:000000009752603

### DTC DETECTION LOGIC

DTC	Trouble diagnosis name	DTC detection condition	Possible causes
P0778	Pressure Control Solenoid B Electrical	<ul style="list-style-type: none"> <li>TCM monitor voltage value for torque secondary pressure solenoid valve is less than 70% of target voltage value for secondary pressure solenoid valve.</li> <li>There is a large difference between TCM current monitor command value for secondary pressure solenoid valve and current monitor value for secondary pressure solenoid valve.</li> </ul>	<ul style="list-style-type: none"> <li>Harness or connectors (Sensor circuit is open or shorted.)</li> <li>Secondary pressure solenoid valve</li> </ul>

### DTC CONFIRMATION PROCEDURE

#### CAUTION:

Always drive vehicle at a safe speed.

#### 1. PREPARATION BEFORE WORK

If another "DTC CONFIRMATION PROCEDURE" occurs just before, turn ignition switch OFF and wait for at least 10 seconds, then perform the next test.

>> GO TO 2.

#### 2. CHECK DTC DETECTION

##### With CONSULT

- Start the engine.
- Drive the vehicle for 10 seconds or more.
- Stop the vehicle.
- Select "Self Diagnostic Results" in "TRANSMISSION".

##### With GST

Follow the procedure "With CONSULT".

Is "P0778" detected?

- YES >> Go to [TM-257, "Diagnosis Procedure"](#).  
 NO >> INSPECTION END

### Diagnosis Procedure

INFOID:000000009752604

#### 1. CHECK SECONDARY PRESSURE SOLENOID VALVE

- Turn ignition switch OFF.
- Disconnect CVT unit connector.
- Check resistance between CVT unit connector terminal and ground.

CVT unit		Ground	Condition	Resistance
Connector	Terminal			
F209	3	Ground	CVT fluid temperature: 20°C (68°F)	Approx. 5.60 – 6.60 Ω
			CVT fluid temperature: 50°C (122°F)	Approx. 6.76 – 6.87 Ω
			CVT fluid temperature: 80°C (176°F)	Approx. 7.47 – 7.59 Ω

Is the inspection result normal?

- YES >> GO TO 2.  
 NO >> GO TO 4.

#### 2. CHECK CIRCUIT BETWEEN TCM AND CVT UNIT (SECONDARY PRESSURE SOLENOID VALVE) (PART 1)

## P0778 PRESSURE CONTROL SOLENOID B

< DTC/CIRCUIT DIAGNOSIS >

[CVT: RE0F10B]

1. Disconnect TCM connector.
2. Check continuity between TCM harness connector terminal and CVT unit harness connector terminal.

TCM		CVT unit		Continuity
Connector	Terminal	Connector	Terminal	
F81	39	F51	3	Existed

Is the inspection result normal?

- YES >> GO TO 3.  
NO >> Repair or replace damaged parts.

### 3. CHECK CIRCUIT BETWEEN TCM AND CVT UNIT (SECONDARY PRESSURE SOLENOID VALVE) (PART 2)

Check continuity between TCM harness connector terminal and ground.

TCM		Ground	Continuity
Connector	Terminal		
F81	39	Ground	Not existed

Is the inspection result normal?

- YES >> Check intermittent incident. Refer to [GI-46, "Intermittent Incident"](#).  
NO >> Repair or replace damaged parts.

### 4. CHECK TERMINAL CORD ASSEMBLY (PART 1)

1. Remove terminal cord assembly. Refer to [TM-322, "Exploded View"](#).
2. Check continuity between CVT unit harness connector terminal and control valve harness connector terminal.

CVT unit		Control valve		Continuity
Connector	Terminal	Connector	Terminal	
F209	3	F208	9	Existed

Is the inspection result normal?

- YES >> GO TO 5.  
NO >> Repair or replace damaged parts.

### 5. CHECK TERMINAL CORD ASSEMBLY (PART 2)

Check terminal cord assembly harness cladding for damage.

Is the inspection result normal?

- YES >> Replace the transaxle assembly. Refer to [TM-339, "2WD : Removal and Installation"](#) (2WD) or [TM-342, "AWD : Removal and Installation"](#) (AWD).  
NO >> Repair or replace damaged parts.

# P0826 UP AND DOWN SHIFT SW

< DTC/CIRCUIT DIAGNOSIS >

[CVT: RE0F10B]

## P0826 UP AND DOWN SHIFT SW

### DTC Logic

INFOID:000000009752605

### DTC DETECTION LOGIC

DTC	Trouble diagnosis name	DTC detection condition	Possible causes
P0826	Up and Down Shift Switch Circuit	<ul style="list-style-type: none"><li>When an impossible pattern of switch signals is detected, a malfunction is detected.</li><li>When shift up/down signal of paddle shifter continuously remains ON for 60 seconds.</li></ul>	<ul style="list-style-type: none"><li>Manual mode select switch</li><li>Manual mode position select switch</li><li>Combination meter</li><li>Harness or connectors</li><li>(Manual mode switch circuit are open or shorted.)</li><li>(Paddle shifter switch circuit are open or shorted.)</li><li>(CAN communication line is open or shorted.)</li><li>Paddle shifter</li></ul>

#### NOTE:

Paddle shifter is applied to NISMO RS models.

### DTC CONFIRMATION PROCEDURE

#### 1. PREPARATION BEFORE WORK

If another "DTC CONFIRMATION PROCEDURE" occurs just before, turn ignition switch OFF and wait for at least 10 seconds, then perform the next test.

>> GO TO 2.

#### 2. CHECK DTC DETECTION (PART 1)

##### With CONSULT

- Start the engine.
- Shift the selector lever to "D" position and wait for 60 seconds or more.
- Select "Self Diagnostic Results" in "TRANSMISSION".

Is "P0826" detected?

- YES >> Go to [TM-260, "Diagnosis Procedure"](#).  
NO >> GO TO 3.

#### 3. CHECK DTC DETECTION (PART 2)

##### With CONSULT

- Shift the selector lever to manual shift gate and wait for 1 second or more.
- Select "Self Diagnostic Results" in "TRANSMISSION".

Is "P0826" detected?

- YES >> Go to [TM-260, "Diagnosis Procedure"](#).  
NO >> GO TO 4.

#### 4. CHECK DTC DETECTION (PART 3)

##### With CONSULT

- Shift the selector lever to "UP side (+ side)" and wait for 1 second or more.
- Select "Self Diagnostic Results" in "TRANSMISSION".

Is "P0826" detected?

- YES >> Go to [TM-260, "Diagnosis Procedure"](#).  
NO >> GO TO 5.

#### 5. CHECK DTC DETECTION (PART 4)

##### With CONSULT

- Shift the selector lever to "DOWN side (- side)" and wait for 1 second or more.
- Select "Self Diagnostic Results" in "TRANSMISSION".

# P0826 UP AND DOWN SHIFT SW

< DTC/CIRCUIT DIAGNOSIS >

[CVT: RE0F10B]

Is "P0826" detected?

- YES >> Go to [TM-260, "Diagnosis Procedure"](#).
- NO >> INSPECTION END

## Diagnosis Procedure

INFOID:000000009752606

### 1. CHECK DTC (COMBINATION METER)

 With CONSULT

1. Turn ignition switch ON.
2. Select "Self Diagnostic Results" in "METER/M&A".

Is any DTC detected?

- YES >> Check DTC detected item. Refer to [MWI-32, "DTC Index"](#).
- NO >> GO TO 2.

### 2. CHECK MANUAL MODE SWITCH SIGNALS

 With CONSULT

1. Turn ignition switch ON.
2. Select "Data Monitor" in "TRANSMISSION".
3. Check the On/Off operations of each monitor item.

Item name	Monitor item	Condition	Status
Manual mode switch	MMODE	Manual shift gate position	On
		Other than the above	Off
	NONMMODE	Manual shift gate position	Off
		Other than the above	On
	UPLVR	Selector lever: UP (+ side)	On
		Other than the above	Off
DOWNLVR	Selector lever: DOWN (- side)	On	
	Other than the above	Off	
Paddle shifter*	STRDWNSW	Pressed paddle shifter (shift-down)	On
		Released paddle shifter	Off
	STRUPSW	Pressed paddle shifter (shift-up)	On
		Released paddle shifter	Off

\*: NISMO RS models

 Without CONSULT

Drive vehicle in the manual mode, and confirm that the actual gear position and the meter's indication of the position mutually coincide when the selector lever and paddle shifter\* are shifted to the "+ (up)" or "- (down)" side [1st ⇔ 6th (8th<sup>\*2</sup>) gear].

\*1: With paddle shifter

\*2: NISMO RS models

Is the inspection result normal?

- YES >> Check intermittent incident. Refer to [GI-46, "Intermittent Incident"](#).
- NO-1 (Manual mode switch is abnormal)>>GO TO 3.
- NO-2 (Paddle shifter is abnormal)>>GO TO 8.

### 3. CHECK MANUAL MODE SWITCH POWER SUPPLY CIRCUIT

1. Turn ignition switch OFF.
2. Disconnect CVT shift selector connector.
3. Turn ignition switch ON.
4. Check voltage between CVT shift selector harness connector terminal and ground.

# P0826 UP AND DOWN SHIFT SW

< DTC/CIRCUIT DIAGNOSIS >

[CVT: RE0F10B]

+		-	Condition	Voltage (Approx.)
CVT shift selector				
Connector	Terminal			
M57	7	Ground	Ignition switch: ON	12 V
			Ignition switch: OFF	0 V
	8		Ignition switch: ON	12 V
			Ignition switch: OFF	0 V
	9		Ignition switch: ON	12 V
			Ignition switch: OFF	0 V
	11		Ignition switch: ON	12 V
			Ignition switch: OFF	0 V

Is the inspection result normal?

YES >> GO TO 4.

NO >> GO TO 5.

## 4. CHECK MANUAL MODE SWITCH

1. Turn ignition switch OFF.
2. Check manual mode switch. Refer to [TM-263, "Component Inspection \(Manual Mode Switch\)"](#).

Is the inspection result normal?

YES >> GO TO 7.

NO >> Repair or replace damaged parts.

## 5. CHECK CIRCUIT BETWEEN CVT SHIFT SELECTOR AND COMBINATION METER (PART 1)

1. Turn ignition switch OFF.
2. Disconnect combination meter connector.
3. Check continuity between CVT shift selector harness connector terminals and combination meter harness connector terminals.

CVT shift selector		Combination meter		Continuity
Connector	Terminal	Connector	Terminal	
M57	7	M34	36	Existed
	8		16	
	9		14	
	11		37	

Is the inspection result normal?

YES >> GO TO 6.

NO >> Repair or replace damaged parts.

## 6. CHECK CIRCUIT BETWEEN CVT SHIFT SELECTOR AND COMBINATION METER (PART 2)

Check continuity between CVT shift selector harness connector terminals and ground.

CVT shift selector		—	Continuity
Connector	Terminal		
M57	7	Ground	Not existed
	8		
	9		
	11		

Is the inspection result normal?

YES >> Check intermittent incident. Refer to [GI-46, "Intermittent Incident"](#).

# P0826 UP AND DOWN SHIFT SW

[CVT: RE0F10B]

## < DTC/CIRCUIT DIAGNOSIS >

NO >> Repair or replace damaged parts.

### 7.CHECK GROUND CIRCUIT

Check continuity between CVT shift selector harness connector terminal and ground.

CVT shift selector		—	Continuity
Connector	Terminal		
M57	10	Ground	Existed

Is the inspection result normal?

YES >> Check intermittent incident. Refer to [GI-46, "Intermittent Incident"](#).

NO >> Repair or replace damaged parts.

### 8.CHECK PADDLE SHIFTER

1. Turn ignition switch OFF.
2. Disconnect paddle shifter connector.
3. Turn ignition switch ON.
4. Check voltage between paddle shifter side harness connector terminals.

Paddle shifter			Voltage (Approx.)
Connector	Terminal		
M96	3	1	Battery voltage
M97	3	1	

Is the inspection result normal?

YES >> GO TO 9.

NO >> GO TO 11.

### 9.CHECK PADDLE SHIFTER

Check paddle shifter. Refer to [TM-264, "Component Inspection \(Paddle Shifter\)"](#).

Is the inspection result normal?

YES >> GO TO 10.

NO >> Repair or replace damaged parts.

### 10.CHECK GROUND CIRCUIT

Check continuity between paddle shifter vehicle side harness connector terminal and ground.

Paddle shifter		Ground	Continuity
Connector	Terminal		
M96	1		Existed
M97	1		

Is the inspection result normal?

YES >> GO TO 11.

NO >> Repair or replace damaged parts.

### 11.CHECK POWER SOURCE CIRCUIT

Check voltage between paddle shifter vehicle side harness connector terminal and ground.

Paddle shifter		Ground	Voltage (Approx.)
Connector	Terminal		
M96	3		0 V
M97	3		

Is the inspection result normal?

YES >> GO TO 12.

# P0826 UP AND DOWN SHIFT SW

< DTC/CIRCUIT DIAGNOSIS >

[CVT: RE0F10B]

NO >> Repair or replace damaged parts.

## 12.CHECK HARNESS BETWEEN PADDLE SHIFTER AND COMBINATION METER (PART 1)

1. Disconnect combination meter connector.
2. Check continuity between paddle shifter vehicle side harness connector terminals and combination meter vehicle side harness connector terminals.

Paddle shifter		Combination meter		Continuity
Connector	Terminal	Connector	Terminal	
M96	3	M34	26	Existed
M97	3		5	

Is the inspection result normal?

YES >> GO TO 13.

NO >> Repair or replace damaged parts.

## 13.CHECK HARNESS BETWEEN PADDLE SHIFTER AND COMBINATION METER (PART 2)

Check continuity between paddle shifter vehicle side harness connector terminals and ground.

Paddle shifter		Ground	Continuity
Connector	Terminal		
M96	3		Not existed
M97	3		

Is the inspection result normal?

YES >> GO TO 14.

NO >> Repair or replace damaged parts.

## 14.DETECT MALFUNCTIONING ITEMS

Check TCM connector pin terminals for damage or loose connection with harness connector.

Is the inspection result normal?

YES >> Replace TCM. Refer to [TM-320, "Exploded View"](#).

NO >> Repair or replace damaged parts.

## Component Inspection (Manual Mode Switch)

INFOID:000000009752607

### MANUAL MODE SWITCH

#### 1.MANUAL MODE SWITCH

Check continuity between CVT shift selector connector terminals.

CVT shift selector	Condition	Continuity
Terminal		
7 – 10	Manual shift gate position (neutral)	Existed
	Other than the above	Not existed
8 – 10	Selector lever: DOWN (– side)	Existed
	Other than the above	Not existed
9 – 10	Selector lever: UP (+ side)	Existed
	Other than the above	Not existed
11 – 10	Manual shift gate position	Not existed
	Other than the above	Existed

Is the inspection result normal?

YES >> INSPECTION END

# P0826 UP AND DOWN SHIFT SW

< DTC/CIRCUIT DIAGNOSIS >

[CVT: RE0F10B]

NO >> There is a malfunction of the manual mode switch. Replace the CVT shift selector assembly.  
Refer to [TM-307, "Removal and Installation"](#).

## Component Inspection (Paddle Shifter)

INFOID:0000000010206677

### 1. CHECK PADDLE SHIFTER

Check continuity between paddle shifter connector terminals.

Paddle shifter		Condition	Continuity
Terminal			
1	3	Pressed paddle shifter (shift-up)	Existed
		Released paddle shifter	Not existed
1	3	Pressed paddle shifter (shift-down)	Existed
		Released paddle shifter	Not existed

Is the inspection result normal?

YES >> INSPECTION END

NO >> Repair or replace damaged parts.



# P0840 TRANSMISSION FLUID PRESSURE SEN/SW A

< DTC/CIRCUIT DIAGNOSIS >

[CVT: RE0F10B]

## P0840 TRANSMISSION FLUID PRESSURE SEN/SW A

### DTC Logic

INFOID:000000009752608

### DTC DETECTION LOGIC

DTC	Trouble diagnosis name	DTC detection condition	Possible causes
P0840	Transmission Fluid Pressure Sensor/Switch A Circuit	<ul style="list-style-type: none"> <li>Secondary pressure sensor voltage that TCM receives is more than 4.7 V</li> <li>Secondary pressure sensor voltage that TCM receives is less than 0.9 V</li> </ul>	<ul style="list-style-type: none"> <li>Harness or connectors (Secondary pressure sensor circuit is open or shorted.)</li> <li>Secondary pressure sensor</li> </ul>

### DTC CONFIRMATION PROCEDURE

#### 1. PREPARATION BEFORE WORK

If another "DTC CONFIRMATION PROCEDURE" occurs just before, turn ignition switch OFF and wait for at least 10 seconds, then perform the next test.

>> GO TO 2.

#### 2. CHECK DTC DETECTION

##### With CONSULT

- Start the engine.
- Select "Data Monitor" in "TRANSMISSION".
- Select "ATF TEMP SEN".
- Maintain the following condition for 5 seconds or more.

ATF TEMP SEN : 2.41 V or less

- Select "Self Diagnostic Results" in "TRANSMISSION".

##### With GST

Follow the procedure "With CONSULT".

Is "P0840" detected?

YES >> Go to [TM-265. "Diagnosis Procedure"](#).

NO >> INSPECTION END

### Diagnosis Procedure

INFOID:000000009752609

#### 1. CHECK TCM INPUT SIGNAL

- Start the engine.
- Check voltage between TCM connector terminals.

Connector	TCM		Condition	Voltage (Approx.)
	+	-		
Terminal				
F81	15	25	<ul style="list-style-type: none"> <li>Selector lever : "N" position</li> <li>At idle</li> </ul>	1.0 V

Is the inspection result normal?

YES >> Check intermittent incident. Refer to [GI-46. "Intermittent Incident"](#).

NO >> GO TO 2.

#### 2. CHECK SENSOR POWER AND SENSOR GROUND

Check voltage between TCM connector terminals.

# P0840 TRANSMISSION FLUID PRESSURE SEN/SW A

< DTC/CIRCUIT DIAGNOSIS >

[CVT: RE0F10B]

TCM			Condition	Voltage (Approx.)
Connector	+	-		
	Terminal			
F81	26	25	Ignition switch: ON	5.0 V
			Ignition switch: OFF	0 V

Is the inspection result normal?

YES >> GO TO 3.

NO >> Go to [TM-272, "Diagnosis Procedure"](#).

## 3. CHECK CIRCUIT BETWEEN TCM AND CVT UNIT (SECONDARY PRESSURE SENSOR) (PART 1)

1. Turn ignition switch OFF.
2. Disconnect TCM connector and CVT unit connector.
3. Check continuity between TCM harness connector terminals and CVT unit harness connector terminals.

TCM		CVT unit		Continuity
Connector	Terminal	Connector	Terminal	
F81	15	F51	23	Existed
	25		19	
	26		20	

Is the inspection result normal?

YES >> GO TO 4.

NO >> Repair or replace damaged parts.

## 4. CHECK CIRCUIT BETWEEN TCM AND CVT UNIT (SECONDARY PRESSURE SENSOR) (PART 2)

Check continuity between TCM harness connector terminals and ground.

TCM		—	Continuity
Connector	Terminal		
F81	15	Ground	Not existed
	25		
	26		

Is the inspection result normal?

YES >> GO TO 5.

NO >> Repair or replace damaged parts.

## 5. CHECK TERMINAL CORD ASSEMBLY (PART 1)

1. Remove terminal cord assembly. Refer to [TM-322, "Exploded View"](#).
2. Check continuity between CVT unit harness connector terminals and control valve harness connector terminals.

CVT unit		Control valve		Continuity
Connector	Terminal	Connector	Terminal	
F209	19	F208	21	Existed
	20		19	
	23		20	

Is the inspection result normal?

YES >> GO TO 6.

NO >> Repair or replace damaged parts.

## 6. CHECK TERMINAL CORD ASSEMBLY (PART 2)

# P0840 TRANSMISSION FLUID PRESSURE SEN/SW A

< DTC/CIRCUIT DIAGNOSIS >

[CVT: RE0F10B]

Check terminal cord assembly harness cladding for damage.

Is the inspection result normal?

YES >> GO TO 7.

NO >> Repair or replace damaged parts.

## 7. CHECK DTC (TCM)

### With CONSULT

1. Perform "DTC CONFIRMATION PROCEDURE". Refer to [TM-265, "DTC Logic"](#).

2. Select "Self Diagnostic Results" in "TRANSMISSION".

Is "P0840" detected?

YES-1 (Only "P0840" is detected)>>There is a malfunction of the secondary pressure sensor. Replace the control valve. Refer to [TM-322, "Removal and Installation"](#).

YES-2 ("P0840" and other than "P0840" are detected)>>Replace the transaxle assembly. Refer to [TM-339, "2WD : Removal and Installation"](#) (2WD) or [TM-342, "AWD : Removal and Installation"](#) (AWD).

NO >> Check intermittent incident. Refer to [GI-46, "Intermittent Incident"](#).

A  
B  
C  
TM  
E  
F  
G  
H  
I  
J  
K  
L  
M  
N  
O  
P

# P0841 TRANSMISSION FLUID PRESSURE SEN/SW A

< DTC/CIRCUIT DIAGNOSIS >

[CVT: RE0F10B]

## P0841 TRANSMISSION FLUID PRESSURE SEN/SW A

### Description

INFOID:000000009752610

Using the engine load (throttle position), the primary pulley revolution speed, and the secondary pulley revolution speed as input signal, TCM changes the operating pressure of the primary pulley and the secondary pulley and changes the groove width of the pulley to control the gear ratio.

### DTC Logic

INFOID:000000009752611

### DTC DETECTION LOGIC

DTC	Trouble diagnosis name	DTC detection condition	Possible causes
P0841	Transmission Fluid Pressure Sensor/Switch A Circuit Range/Performance	Secondary pressure sensor value exceeds line pressure value	<ul style="list-style-type: none"><li>• Harness or connectors (Sensor circuit is open or shorted.)</li><li>• Secondary pressure sensor</li></ul>

### DTC CONFIRMATION PROCEDURE

#### CAUTION:

**Always drive vehicle at a safe speed.**

#### 1. PREPARATION BEFORE WORK

If another "DTC CONFIRMATION PROCEDURE" occurs just before, turn ignition switch OFF and wait for at least 10 seconds, then perform the next test.

>> GO TO 2.

#### 2. CHECK DTC DETECTION

##### With CONSULT

1. Start the engine.
2. Select "Data Monitor" in "TRANSMISSION".
3. Select "VEHICLE SPEED".
4. Drive the vehicle.
5. Maintain the following condition for 5 seconds or more.

VEHICLE SPEED : 30 km/h (19 MPH) or more

6. Stop the vehicle.
7. Select "Self Diagnostic Results" in "TRANSMISSION".

Is "P0841" detected?

- YES >> Go to [TM-268, "Diagnosis Procedure"](#).  
NO >> INSPECTION END

### Diagnosis Procedure

INFOID:000000009752612

#### 1. CHECK LINE PRESSURE

Perform line pressure test. Refer to [TM-221, "Inspection and Judgment"](#).

Is the inspection result normal?

- YES >> GO TO 2.  
NO >> Repair or replace damaged parts. Refer to [TM-221, "Inspection and Judgment"](#).

#### 2. CHECK SECONDARY PRESSURE SENSOR SYSTEM

Check secondary pressure sensor system. Refer to [TM-265, "DTC Logic"](#).

Is the inspection result normal?

- YES >> GO TO 3.  
NO >> Repair or replace damaged parts.

#### 3. CHECK LINE PRESSURE SOLENOID VALVE

Check line pressure solenoid valve. Refer to [TM-251, "DTC Logic"](#).

# P0841 TRANSMISSION FLUID PRESSURE SEN/SW A

< DTC/CIRCUIT DIAGNOSIS >

[CVT: RE0F10B]

Is the inspection result normal?

YES >> GO TO 4.

NO >> Repair or replace damaged parts.

## 4.CHECK SECONDARY PRESSURE SOLENOID VALVE

Check secondary pressure solenoid valve. Refer to [TM-257, "DTC Logic"](#).

Is the inspection result normal?

YES >> GO TO 5.

NO >> Repair or replace damaged parts.

## 5.CHECK STEP MOTOR SYSTEM

Check step motor system. Refer to [TM-284, "DTC Logic"](#).

Is the inspection result normal?

YES >> GO TO 6.

NO >> Repair or replace damaged parts.

## 6.CHECK INTERMITTENT INCIDENT

Refer to [GI-46, "Intermittent Incident"](#).

Is the inspection result normal?

YES >> Replace the transaxle assembly. Refer to [TM-339, "2WD : Removal and Installation"](#) (2WD) or [TM-342, "AWD : Removal and Installation"](#) (AWD).

NO >> Repair or replace damaged parts.

A  
B  
C  
TM  
E  
F  
G  
H  
I  
J  
K  
L  
M  
N  
O  
P

# P0868 TRANSMISSION FLUID PRESSURE

< DTC/CIRCUIT DIAGNOSIS >

[CVT: RE0F10B]

## P0868 TRANSMISSION FLUID PRESSURE

### Description

INFOID:000000009752613

The secondary pressure solenoid valve regulates the secondary pressure to suit the driving condition in response to a signal sent from the TCM.

### DTC Logic

INFOID:000000009752614

### DTC DETECTION LOGIC

DTC	Trouble diagnosis name	DTC detection condition	Possible causes
P0868	Transmission Fluid Pressure Low	Secondary pressure is abnormally low compared with the target secondary pressure during ordinary driving.	<ul style="list-style-type: none"><li>• Harness or connectors (Sensor circuit is open or shorted.)</li><li>• Line pressure control system</li><li>• Secondary pressure solenoid valve system</li><li>• Secondary pressure sensor</li></ul>

### DTC CONFIRMATION PROCEDURE

#### CAUTION:

**Always drive vehicle at a safe speed.**

#### 1. PREPARATION BEFORE WORK

If another "DTC CONFIRMATION PROCEDURE" occurs just before, turn ignition switch OFF and wait for at least 10 seconds, then perform the next test.

>> GO TO 2.

#### 2. CHECK DTC DETECTION

##### Ⓟ With CONSULT

1. Start the engine.
2. Select "Data Monitor" in "TRANSMISSION".
3. Select "RANGE", "ATF TEMP SEN", "ACC PEDAL OPEN", "BRAKE SW" and "VEHICLE SPEED".
4. Drive the vehicle.
5. Maintain the following condition for 30 seconds or more.

RANGE	: "D" position
ATF TEMP SEN	: 2.41 V or less
ACC PEDAL OPEN	: 0.5/8 – 1.0/8
BRAKE SW	: Off
VEHICLE SPEED	: 40 km/h (25 MPH) or more

6. Stop the vehicle.
7. Select "Self Diagnostic Results" in "TRANSMISSION".

Is "P0868" detected?

- YES >> Go to [TM-270, "Diagnosis Procedure"](#).  
NO >> INSPECTION END

### Diagnosis Procedure

INFOID:000000009752615

#### 1. CHECK LINE PRESSURE

Perform line pressure test. Refer to [TM-221, "Inspection and Judgment"](#).

Is the inspection result normal?

- YES >> GO TO 2.  
NO >> Repair or replace damaged parts. Refer to [TM-221, "Inspection and Judgment"](#).

#### 2. CHECK LINE PRESSURE SOLENOID VALVE

Check line pressure solenoid valve. Refer to [TM-251, "DTC Logic"](#).

# P0868 TRANSMISSION FLUID PRESSURE

[CVT: RE0F10B]

< DTC/CIRCUIT DIAGNOSIS >

Is the inspection result normal?

YES >> GO TO 3.

NO >> Repair or replace damaged parts.

## 3.CHECK SECONDARY PRESSURE SOLENOID VALVE

Check secondary pressure solenoid valve. Refer to [TM-257, "DTC Logic"](#).

Is the inspection result normal?

YES >> GO TO 4.

NO >> Repair or replace damaged parts.

## 4.CHECK SECONDARY PRESSURE SENSOR SYSTEM

Check secondary pressure sensor system. Refer to [TM-265, "DTC Logic"](#).

Is the inspection result normal?

YES >> GO TO 5.

NO >> Repair or replace damaged parts.

## 5.CHECK INTERMITTENT INCIDENT

Refer to [GI-46, "Intermittent Incident"](#).

Is the inspection result normal?

YES >> Replace the transaxle assembly. Refer to [TM-339, "2WD : Removal and Installation"](#) (2WD) or [TM-342, "AWD : Removal and Installation"](#) (AWD).

NO >> Repair or replace damaged parts.

A  
B  
C  
TM  
E  
F  
G  
H  
I  
J  
K  
L  
M  
N  
O  
P

P1701 TCM

Description

INFOID:000000009752616

When the power supply to the TCM is cut OFF, for example because the battery is removed, and the self-diagnosis memory function stops, malfunction is detected.

**CAUTION:**

**Immediately after TCM is replaced or after control valve or transaxle assembly is replaced (after TCM initialization is complete), self-diagnosis result of "P1701" may be displayed. In this case, erase self-diagnosis result using CONSULT. After erasing self-diagnosis result, perform DTC P1701 reproduction procedure and check that malfunction is not detected.**

DTC Logic

INFOID:000000009752617

DTC DETECTION LOGIC

DTC	Trouble diagnosis name	DTC detection condition	Possible causes
P1701	Power Supply Circuit	Power supply (backup) of TCM is not supplied and learning function stops	<ul style="list-style-type: none"> <li>Harness or connectors (TCM power supply circuit is open or shorted.)</li> </ul>

DTC CONFIRMATION PROCEDURE

**CAUTION:**

**Always drive vehicle at a safe speed.**

**1. PREPARATION BEFORE WORK**

If another "DTC CONFIRMATION PROCEDURE" occurs just before, turn ignition switch OFF and wait for at least 10 seconds, then perform the next test.

>> GO TO 2.

**2. CHECK DTC DETECTION**

**With CONSULT**

- Start the engine.
- Run engine for 10 seconds or more at idle speed.
- Drive the vehicle for 10 seconds or more.
- Select "Data Monitor" in "TRANSMISSION".
- Stop the vehicle.
- Turn ignition switch OFF and wait for 2 seconds or more.
- Start the engine.
- Select "Self Diagnostic Results" in "TRANSMISSION".

Is "P1701" detected?

- YES >> Go to [TM-272, "Diagnosis Procedure"](#).
- NO >> INSPECTION END

Diagnosis Procedure

INFOID:000000009752618

**1. CHECK TCM POWER SUPPLY CIRCUIT (PART 1)**

- Turn ignition switch OFF.
- Disconnect TCM connector.
- Turn ignition switch ON.
- Check voltage between TCM harness connector terminals and ground.



< DTC/CIRCUIT DIAGNOSIS >

+		-	Condition	Voltage
TCM				
Connector	Terminal			
F81	46	Ground	Ignition switch: ON	10 V – 16 V
			Ignition switch: OFF	Approx. 0 V
	48		Ignition switch: ON	10 V – 16 V
			Ignition switch: OFF	Approx. 0 V

Is the inspection result normal?

- YES >> GO TO 2.
- NO >> GO TO 3.

**2. CHECK TCM POWER SUPPLY CIRCUIT (PART 2)**

1. Turn ignition switch OFF.
2. Check voltage between TCM harness connector terminal and ground.

+		-	Voltage
TCM			
Connector	Terminal		
F81	47	Ground	10 V – 16 V

Is the inspection result normal?

- YES >> GO TO 6.
- NO >> GO TO 5.

**3. CHECK CIRCUIT BETWEEN TCM AND IPDM E/R**

1. Turn ignition switch OFF.
2. Disconnect IPDM E/R connector.
3. Check continuity between TCM harness connector terminals and IPDM E/R harness connector terminal.

TCM		IPDM E/R		Continuity
Connector	Terminal	Connector	Terminal	
F81	46	E15	57	Existed
	48			

Is the inspection result normal?

- YES >> GO TO 4.
- NO >> Repair or replace damaged parts.

**4. DETECT MALFUNCTIONING ITEM**

Check the following:

- Open circuit or short circuit in harness between ignition switch and IPDM E/R. Refer to [PG-41, "Wiring Diagram - IGNITION POWER SUPPLY -"](#).
- Short circuit in harness between IPDM E/R harness connector terminal 57 and TCM harness connector terminal 46, and 48.
- 10A fuse (No. 55, located in IPDM E/R). Refer to [PG-64, "Fuse, Connector and Terminal Arrangement"](#).
- IPDM E/R
- Ignition switch

Is the inspection result normal?

- YES >> Check intermittent incident. Refer to [GI-46, "Intermittent Incident"](#).
- NO >> Repair or replace damaged parts.

**5. DETECT MALFUNCTIONING ITEM**

Check the following:

A  
B  
C  
TM  
E  
F  
G  
H  
I  
J  
K  
L  
M  
N  
O  
P

# P1701 TCM

[CVT: RE0F10B]

## < DTC/CIRCUIT DIAGNOSIS >

- Open circuit or short circuit in harness between battery and TCM harness connector terminal 47. Refer to [PG-11, "Wiring Diagram - BATTERY POWER SUPPLY -"](#).
- 10A fuse (No. 33, located in fuse and fusible link block). Refer to [PG-63, "Fuse and Fusible Link Arrangement"](#).

Is the inspection result normal?

YES >> Check intermittent incident. Refer to [GI-46, "Intermittent Incident"](#).

NO >> Repair or replace damaged parts.

## 6. CHECK CIRCUIT BETWEEN TCM AND GROUND

Check continuity between TCM harness connector terminals and ground.

TCM		—	Continuity
Connector	Terminal		
F81	5	Ground	Existed
	42		

Is the inspection result normal?

YES >> Check intermittent incident. Refer to [GI-46, "Intermittent Incident"](#).

NO >> Repair or replace damaged parts.

# P1705 TP SENSOR

< DTC/CIRCUIT DIAGNOSIS >

[CVT: RE0F10B]

## P1705 TP SENSOR

### Description

INFOID:000000009752619

Electric throttle control actuator consists of throttle control motor, accelerator pedal position sensor, throttle position sensor etc. The actuator sends a signal to the ECM, and ECM sends the signal to TCM with CAN communication.

### DTC Logic

INFOID:000000009752620

### DTC DETECTION LOGIC

DTC	Trouble diagnosis name	DTC detection condition	Possible causes
P1705	Accelerator Pedal Position Sensor Signal Circuit	TCM detects that difference between the 2 accelerator pedal position signals (CAN communication) from ECM is 1/8 or more	<ul style="list-style-type: none"><li>• Harness or connectors (CAN communication line is open or shorted.) (Accelerator pedal position sensor circuit is open or shorted.)</li><li>• ECM</li></ul>

### DTC CONFIRMATION PROCEDURE

#### 1. PREPARATION BEFORE WORK

If another "DTC CONFIRMATION PROCEDURE" occurs just before, turn ignition switch OFF and wait for at least 10 seconds, then perform the next test.

>> GO TO 2.

#### 2. CHECK DTC DETECTION

##### With CONSULT

1. Start the engine.
2. Apply the parking brake.
3. Depress the accelerator pedal gradually.
4. Release your foot from the accelerator pedal.
5. Select "Self Diagnostic Results" in "TRANSMISSION".

Is "P1705" detected?

- YES >> Go to [TM-275, "Diagnosis Procedure"](#).  
NO >> INSPECTION END

### Diagnosis Procedure

INFOID:000000009752621

#### 1. CHECK DTC (ECM)

##### With CONSULT

1. Turn ignition switch ON.
2. Select "Self Diagnostic results" in "ENGINE".

Is any DTC detected?

- YES >> Check DTC detected item. Refer to [EC-101, "DTC Index"](#).  
NO >> Check intermittent incident. Refer to [GI-46, "Intermittent Incident"](#).

# P1709 INCOMPLETED DATA WRITING

< DTC/CIRCUIT DIAGNOSIS >

[CVT: RE0F10B]

## P1709 INCOMPLETED DATA WRITING

### Description

INFOID:000000009752622

When TCM does not store calibration data (individual characteristic value) of each solenoid valve that is stored in the ROM assembly (in the control valve), a malfunction is detected.

#### CAUTION:

**Immediately after TCM is replaced or after control valve or transaxle assembly is replaced (after TCM initialization is complete), self-diagnosis result of "P1709" may be displayed. In this case, erase self-diagnosis result using CONSULT. After erasing self-diagnosis result, perform DTC P1701 reproduction procedure and check that malfunction is not detected.**

### DTC Logic

INFOID:000000009752623

### DTC DETECTION LOGIC

DTC	Trouble diagnosis name	DTC is detected if...	Possible cause
P1709	Incompleted Data Writing	When TCM does not store calibration data (individual characteristic value) of each solenoid valve that is stored in the ROM assembly (in the control valve).	<ul style="list-style-type: none"><li>• Harness or connectors (ROM assembly circuit is open or shorted.)</li><li>• TCM</li><li>• ROM assembly (in the control valve)</li></ul>

### DTC CONFIRMATION PROCEDURE

#### NOTE:

Immediately after performing any "DTC CONFIRMATION PROCEDURE", always turn ignition switch OFF. Then wait at least 10 seconds before performing the next test.

#### 1. CHECK DTC DETECTION

#### ⓑ With CONSULT

1. Turn ignition switch OFF.
2. Wait for at least 10 consecutive seconds.
3. Turn ignition switch ON.
4. Perform "Self Diagnostic Results" in "TRANSMISSION".

#### Is "P1709" detected?

- YES >> Go to [TM-276, "Diagnosis Procedure"](#).  
NO >> INSPECTION END

### Diagnosis Procedure

INFOID:000000009752624

#### 1. CHECK HARNESS BETWEEN TCM AND CVT UNIT HARNESS CONNECTOR (ROM ASSEMBLY) (PART 1)

1. Turn ignition switch OFF.
2. Disconnect TCM connector and CVT unit connector.
3. Check continuity between TCM vehicle side harness connector terminals and CVT unit vehicle side harness connector terminals.

TCM		CVT unit		Continuity
Connector	Terminal	Connector	Terminal	
F81	8	F51	11	Existed
	9		1	
	10		16	
	25		19	
	26		20	

#### Is the inspection result normal?

- YES >> GO TO 2.  
NO >> Repair or replace damaged parts.

# P1709 INCOMPLETED DATA WRITING

< DTC/CIRCUIT DIAGNOSIS >

[CVT: RE0F10B]

## 2. CHECK HARNESS BETWEEN TCM AND CVT UNIT HARNESS CONNECTOR (ROM ASSEMBLY) (PART 2)

Check continuity between TCM vehicle side harness connector terminals and ground.

TCM		—	Continuity
Connector	Terminal		
F81	8	Ground	Not existed
	9		
	10		
	25		
	26		

Is the inspection result normal?

YES >> GO TO 3.

NO >> Repair or replace damaged parts.

## 3. CHECK TERMINAL CORD ASSEMBLY

1. Remove terminal cord assembly. Refer to [TM-322, "Exploded View"](#).
2. Check continuity between CVT unit harness terminals and control valve harness connector terminals.

CVT unit		Control valve		Continuity
Connector	Terminal	Connector	Terminal	
F209	1	F207	2	Existed
	11		3	
	16		4	
	19		5	
	20		1	

Is the inspection result normal?

YES >> GO TO 4.

NO >> Repair or replace damaged parts.

## 4. CHECK TCM POWER SUPPLY AND GROUND CIRCUIT

Check TCM power supply and ground circuit. Refer to [TM-272, "Diagnosis Procedure"](#).

Is the inspection result normal?

YES >> GO TO 5.

NO >> Repair or replace damaged parts.

## 5. REPLACE TCM

1. Replace TCM. Refer to [TM-320, "Removal and Installation"](#).
2. Perform "DTC CONFIRMATION PROCEDURE". Refer to [TM-276, "DTC Logic"](#).

Is the inspection result normal?

YES >> INSPECTION END

NO >> Replace transaxle assembly. Refer to [TM-339, "2WD : Removal and Installation"](#) (2WD) or [TM-339, "2WD : Removal and Installation"](#) (AWD).

# P1722 VEHICLE SPEED

< DTC/CIRCUIT DIAGNOSIS >

[CVT: RE0F10B]

## P1722 VEHICLE SPEED

### Description

INFOID:000000009752625

The vehicle speed signal is transmitted from ABS actuator and electric unit (control unit) to TCM by CAN communication line.

### DTC Logic

INFOID:000000009752626

### DTC DETECTION LOGIC

DTC	Trouble diagnosis name	DTC detection condition	Possible causes
P1722	Vehicle Speed Signal Circuit	<ul style="list-style-type: none"><li>• TCM detects malfunction in CAN communication with ABS actuator and electric unit (control unit).</li><li>• When vehicle speed that TCM detects is 10 km/h (7 MPH) or more, vehicle speed signal (CAN communication) that is received from ABS actuator and electric unit (control unit) is 2 km/h (2 MPH) or less.</li><li>• Change of vehicle speed signal (CAN communication) that TCM receives is large</li></ul>	<ul style="list-style-type: none"><li>• Harness or connectors (CAN communication line is open or shorted.) (Vehicle speed signal circuit is open or shorted.)</li><li>• ABS actuator and electric unit (control unit)</li></ul>

### DTC CONFIRMATION PROCEDURE

#### CAUTION:

Always drive vehicle at a safe speed.

#### 1. PREPARATION BEFORE WORK

If another "DTC CONFIRMATION PROCEDURE" occurs just before, turn ignition switch OFF and wait for at least 10 seconds, then perform the next test.

>> GO TO 2.

#### 2. CHECK DTC DETECTION

##### Ⓜ With CONSULT

1. Start the engine.
2. Select "Data Monitor" in "TRANSMISSION".
3. Select "VSP SENSOR".
4. Drive the vehicle.
5. Maintain the following condition for 10 seconds or more.

VSP SENSOR : 10 km/h (7 MPH) or more

6. Stop the vehicle.
7. Select "Self Diagnostic Results" in "TRANSMISSION".

Is "P1722" detected?

- YES >> Go to [TM-278, "Diagnosis Procedure"](#).  
NO >> INSPECTION END

### Diagnosis Procedure

INFOID:000000009752627

#### 1. CHECK DTC [ABS ACTUATOR AND ELECTRIC UNIT (CONTROL UNIT)]

##### Ⓜ With CONSULT

1. Turn ignition switch ON.
2. Select "Self Diagnostic Results" in "ABS".

Is any DTC detected?

- YES >> Check DTC detected item. Refer to [BRC-50, "DTC Index"](#)  
NO >> Check intermittent incident. Refer to [GI-46, "Intermittent Incident"](#).

# P1723 SPEED SENSOR

< DTC/CIRCUIT DIAGNOSIS >

[CVT: RE0F10B]

## P1723 SPEED SENSOR

### Description

INFOID:000000009752628

The secondary speed sensor detects the revolution of parking gear and generates a pulse signal. The pulse signal is sent to the TCM, which converts it into vehicle speed.  
The primary speed sensor detects the primary pulley revolution speed and sends a signal to the TCM.

### DTC Logic

INFOID:000000009752629

#### DTC DETECTION LOGIC

**CAUTION:**

One of the "P0715", or the "P0720" is displayed with the DTC at the same time.

DTC	Trouble diagnosis name	DTC detection condition	Possible causes
P1723	Speed Sensor Circuit	TCM detects that high frequency components that are extracted from primary pulley speed and secondary pulley speed exceed a certain value	<ul style="list-style-type: none"> <li>Harness or connectors (Primary speed sensor circuit is open or shorted.)</li> <li>(Secondary speed sensor circuit is open or shorted.)</li> </ul>

#### DTC CONFIRMATION PROCEDURE

**CAUTION:**

Always drive vehicle at a safe speed.

#### 1. PREPARATION BEFORE WORK

If another "DTC CONFIRMATION PROCEDURE" occurs just before, turn ignition switch OFF and wait for at least 10 seconds, then perform the next test.

>> GO TO 2.

#### 2. CHECK DTC DETECTION

 With CONSULT

- Start the engine.
- Select "Data Monitor" in "TRANSMISSION".
- Select "RANGE" and "VEHICLE SPEED".
- Drive the vehicle.
- Maintain the following condition for 1 second or more.

RANGE	: "D" position
VEHICLE SPEED	: 20 km/h (13 MPH) or more

- Stop the vehicle.
- Select "Self Diagnostic Results" in "TRANSMISSION".

Is "P1723" detected?

- YES >> Go to [TM-279, "Diagnosis Procedure"](#).  
NO >> INSPECTION END

### Diagnosis Procedure

INFOID:000000009752630

#### 1. CHECK SECONDARY SPEED SENSOR SYSTEM

Check secondary speed sensor system. Refer to [TM-242, "DTC Logic"](#).

Is the inspection result normal?

- YES >> GO TO 2.  
NO >> Repair or replace damaged parts.

#### 2. CHECK PRIMARY SPEED SENSOR SYSTEM

Check primary speed sensor system. Refer to [TM-239, "DTC Logic"](#).

Is the inspection result normal?

## P1723 SPEED SENSOR

< DTC/CIRCUIT DIAGNOSIS >

[CVT: RE0F10B]

- 
- YES >> Check intermittent incident. Refer to [GI-46, "Intermittent Incident"](#).  
NO >> Repair or replace damaged parts.



# P1726 THROTTLE CONTROL SIGNAL

< DTC/CIRCUIT DIAGNOSIS >

[CVT: RE0F10B]

## P1726 THROTTLE CONTROL SIGNAL

### Description

INFOID:000000009752631

Electric throttle control actuator consists of throttle control motor, accelerator pedal position sensor, throttle position sensor etc. The actuator sends a signal to the ECM, and ECM sends the signal to TCM with CAN communication.

### DTC Logic

INFOID:000000009752632

### DTC DETECTION LOGIC

DTC	Trouble diagnosis name	DTC detection condition	Possible causes
P1726	Throttle Control Signal Circuit	TCM receives a malfunction signal of engine system from ECM	Harness or connectors (Electronically controlled throttle sensor signal circuit is open or shorted.)

### DTC CONFIRMATION PROCEDURE

#### 1. PREPARATION BEFORE WORK

If another "DTC CONFIRMATION PROCEDURE" occurs just before, turn ignition switch OFF and wait for at least 10 seconds, then perform the next test.

>> GO TO 2.

#### 2. CHECK DTC DETECTION

##### With CONSULT

1. Start the engine.
2. Run engine for at least 10 consecutive seconds at idle speed.
3. Select "Self Diagnostic Results" in "TRANSMISSION".

Is "P1726" detected?

- YES >> Go to [TM-281, "Diagnosis Procedure"](#).  
NO >> INSPECTION END

### Diagnosis Procedure

INFOID:000000009752633

#### 1. CHECK DTC (ECM)

##### With CONSULT

1. Turn ignition switch ON.
2. Select "Self Diagnostic Results" in "ENGINE".

Is any DTC detected?

- YES >> Check DTC detected item. Refer to [EC-101, "DTC Index"](#).  
NO >> Check intermittent incident. Refer to [GI-46, "Intermittent Incident"](#).

# P1740 SELECT SOLENOID

< DTC/CIRCUIT DIAGNOSIS >

[CVT: RE0F10B]

## P1740 SELECT SOLENOID

### DTC Logic

INFOID:000000009752634

### DTC DETECTION LOGIC

DTC	Trouble diagnosis name	DTC detection condition	Possible causes
P1740	Lock-up Select Solenoid Valve Circuit	<ul style="list-style-type: none"><li>• Monitor value for lock-up select solenoid valve is OFF when TCM command value for lock-up select solenoid valve is ON.</li><li>• Monitor value for lock-up select solenoid valve is ON when TCM command value for lock-up select solenoid valve is OFF.</li></ul>	<ul style="list-style-type: none"><li>• Harness or connectors (Lock-up select solenoid circuit is open or shorted.)</li><li>• Lock-up select solenoid valve</li></ul>

### DTC CONFIRMATION PROCEDURE

#### CAUTION:

Always drive vehicle at a safe speed.

#### 1. PREPARATION BEFORE WORK

If another "DTC CONFIRMATION PROCEDURE" occurs just before, turn ignition switch OFF and wait for at least 10 seconds, then perform the next test.

>> GO TO 2.

#### 2. CHECK DTC DETECTION (PART 1)

##### With CONSULT

1. Start the engine.
2. Select "Data Monitor" in "TRANSMISSION".
3. Select "RANGE".
4. Maintain the following condition for 1 second or more.

RANGE : "P" or "N" position

5. Select "Self Diagnostic Results" in "TRANSMISSION".

##### With GST

Follow the procedure "With CONSULT".

Is "P1740" detected?

- YES >> Go to [TM-282, "Diagnosis Procedure"](#).  
NO >> GO TO 3.

#### 3. CHECK DTC DETECTION (PART 2)

##### With CONSULT

1. Select "Data Monitor" in "TRANSMISSION".
2. Select "RANGE".
3. Maintain the following condition for 1 second or more.

RANGE : "R" or "D" position

4. Select "Self Diagnostic Results" in "TRANSMISSION".

##### With GST

Follow the procedure "With CONSULT".

Is "P1740" detected?

- YES >> Go to [TM-282, "Diagnosis Procedure"](#).  
NO >> INSPECTION END

### Diagnosis Procedure

INFOID:000000009752635

#### 1. CHECK LOCK-UP SELECT SOLENOID VALVE

1. Turn ignition switch OFF.

# P1740 SELECT SOLENOID

[CVT: RE0F10B]

## < DTC/CIRCUIT DIAGNOSIS >

2. Disconnect CVT unit connector.
3. Check resistance between CVT unit connector terminal and ground.

CVT unit		Ground	Condition	Resistance
Connector	Terminal			
F209	13	Ground	CVT fluid temperature: 20°C (68°F)	Approx. 26.0 – 30.0 Ω
			CVT fluid temperature: 50°C (122°F)	Approx. 29.0 – 34.0 Ω
			CVT fluid temperature: 80°C (176°F)	Approx. 32.0 – 37.0 Ω

Is the inspection result normal?

- YES >> GO TO 2.  
 NO >> GO TO 4.

## 2.CHECK CIRCUIT BETWEEN TCM AND CVT UNIT (LOCK-UP SELECT SOLENOID VALVE) (PART 1)

1. Disconnect TCM connector.
2. Check continuity between TCM harness connector terminal and CVT unit harness connector terminal.

TCM		CVT unit		Continuity
Connector	Terminal	Connector	Terminal	
F81	37	F51	13	Existed

Is the inspection result normal?

- YES >> GO TO 3.  
 NO >> Repair or replace damaged parts.

## 3.CHECK CIRCUIT BETWEEN TCM AND CVT UNIT (LOCK-UP SELECT SOLENOID VALVE) (PART 2)

Check continuity between TCM harness connector terminal and ground.

TCM		Ground	Continuity
Connector	Terminal		
F81	37	Ground	Not existed

Is the inspection result normal?

- YES >> Check intermittent incident. Refer to [GI-46, "Intermittent Incident"](#).  
 NO >> Repair or replace damaged parts.

## 4.CHECK TERMINAL CORD ASSEMBLY (PART 1)

1. Remove terminal cord assembly. Refer to [TM-322, "Removal and Installation"](#).
2. Check continuity between CVT unit harness connector terminal and control valve harness connector terminal.

CVT unit		Control valve		Continuity
Connector	Terminal	Connector	Terminal	
F209	13	F208	11	Existed

Is the inspection result normal?

- YES >> GO TO 5.  
 NO >> Repair or replace damaged parts.

## 5.CHECK TERMINAL CORD ASSEMBLY (PART 2)

Check terminal cord assembly harness cladding for damage.

Is the inspection result normal?

- YES >> Replace the transaxle assembly. Refer to [TM-339, "2WD : Removal and Installation"](#) (2WD), [TM-342, "AWD : Removal and Installation"](#) (AWD).  
 NO >> Repair or replace damaged parts.

# P1777 STEP MOTOR

< DTC/CIRCUIT DIAGNOSIS >

[CVT: RE0F10B]

## P1777 STEP MOTOR

### DTC Logic

INFOID:000000009752636

### DTC DETECTION LOGIC

DTC	Trouble diagnosis name	DTC detection condition	Possible causes
P1777	Step Motor Circuit	<ul style="list-style-type: none"><li>Step motor monitor value is OFF when step motor command value of TCM is ON</li><li>Step motor monitor value is ON when step motor command value of TCM is OFF</li></ul>	<ul style="list-style-type: none"><li>Harness or connectors (Step motor circuit is open or shorted.)</li><li>Step motor</li></ul>

### DTC CONFIRMATION PROCEDURE

#### CAUTION:

Always drive vehicle at a safe speed.

#### 1. PREPARATION BEFORE WORK

If another "DTC CONFIRMATION PROCEDURE" occurs just before, turn ignition switch OFF and wait for at least 10 seconds, then perform the next test.

>> GO TO 2.

#### 2. CHECK DTC DETECTION

##### With CONSULT

- Start the engine.
- Select "Data Monitor" in "TRANSMISSION".
- Select "RANGE" and "VEHICLE SPEED".
- Drive the vehicle.
- Maintain the following condition for 1 second or more.

RANGE : "D" position  
VEHICLE SPEED : 20 km/h (13 MPH) or more

- Stop the vehicle.
- Select "Self Diagnostic Results" in "TRANSMISSION".

##### With GST

Follow the procedure "With CONSULT".

Is "P1777" detected?

- YES >> Go to [TM-284, "Diagnosis Procedure"](#).  
NO >> INSPECTION END

### Diagnosis Procedure

INFOID:000000009752637

#### 1. CHECK STEP MOTOR CIRCUIT (PART 1)

- Turn ignition switch OFF.
- Disconnect TCM connector.
- Check resistance between TCM harness connector terminals.

TCM		Resistance
Connector	Terminal	
F81	27 - 28	Approx. 30.0 Ω
	29 - 30	

Is the inspection result normal?

- YES >> GO TO 2.  
NO >> GO TO 3.

#### 2. CHECK STEP MOTOR CIRCUIT (PART 2)

# P1777 STEP MOTOR

< DTC/CIRCUIT DIAGNOSIS >

[CVT: RE0F10B]

Check resistance between TCM harness connector terminals and ground.

TCM		Ground	Resistance
Connector	Terminal		
F81	27	Ground	Approx. 15.0 Ω
	28		
	29		
	30		

Is the inspection result normal?

YES >> Check intermittent incident. Refer to [GI-46. "Intermittent Incident"](#).

NO >> GO TO 3.

## 3.CHECK STEP MOTOR

1. Disconnect CVT unit connector.
2. Check resistance between CVT unit connector terminals.

CVT unit		Resistance
Connector	Terminal	
F209	6 – 7	Approx. 30.0 Ω
	8 – 9	

3. Check resistance between CVT unit connector terminals and ground.

CVT unit		Ground	Resistance
Connector	Terminal		
F209	6	Ground	Approx. 15.0 Ω
	7		
	8		
	9		

Is the inspection result normal?

YES >> GO TO 4.

NO >> GO TO 6.

## 4.CHECK CIRCUIT BETWEEN TCM AND CVT UNIT (STEP MOTOR) (PART 1)

Check continuity between TCM harness connector terminals and CVT unit harness connector terminals.

TCM		CVT unit		Continuity
Connector	Terminal	Connector	Terminal	
F81	27	F51	9	Existed
	28		8	
	29		7	
	30		6	

Is the inspection result normal?

YES >> GO TO 5.

NO >> Repair or replace damaged parts.

## 5.CHECK CIRCUIT BETWEEN TCM AND CVT UNIT (STEP MOTOR) (PART 2)

Check continuity between TCM harness connector terminals and ground.

# P1777 STEP MOTOR

< DTC/CIRCUIT DIAGNOSIS >

[CVT: RE0F10B]

TCM		Ground	Continuity
Connector	Terminal		
F81	27	Ground	Not existed
	28		
	29		
	30		

Is the inspection result normal?

- YES >> Check intermittent incident. Refer to [GI-46, "Intermittent Incident"](#).  
 NO >> Repair or replace damaged parts.

## 6. CHECK TERMINAL CORD ASSEMBLY (PART 1)

- Remove terminal cord assembly. Refer to [TM-322, "Exploded View"](#).
- Check continuity between CVT unit harness connector terminals and control valve harness connector terminals.

CVT unit		Control valve		Continuity
Connector	Terminal	Connector	Terminal	
F209	6	F208	14	Existed
	7		15	
	8		16	
	9		17	

Is the inspection result normal?

- YES >> GO TO 7.  
 NO >> Repair or replace damaged parts.

## 7. CHECK TERMINAL CORD ASSEMBLY (PART 2)

Check terminal cord assembly harness cladding for damage.

Is the inspection result normal?

- YES >> GO TO 8.  
 NO >> Repair or replace damaged parts.

## 8. CHECK DTC (TCM)

### With CONSULT

- Perform "DTC CONFIRMATION PROCEDURE". Refer to [TM-284, "DTC Logic"](#).
- Select "Self Diagnostic Results" in "TRANSMISSION".

Is "P1777" detected?

- YES-1 (Only "P1777" is detected)>>There is a malfunction of the step motor. Replace the control valve. Refer to [TM-322, "Removal and Installation"](#).  
 YES-2 ("P1777" and "P0725"/"P1777" and "U1000"/"P1777", "P0725" and "U1000" are detected)>>Replace the control valve. Refer to [TM-322, "Removal and Installation"](#).  
 YES-3 (Other than YES-1 and YES-2)>>Replace the transaxle assembly. Refer to [TM-339, "2WD : Removal and Installation"](#) (2WD) or [TM-342, "AWD : Removal and Installation"](#) (AWD).  
 NO >> Check intermittent incident. Refer to [GI-46, "Intermittent Incident"](#).

# P1778 STEP MOTOR

< DTC/CIRCUIT DIAGNOSIS >

[CVT: RE0F10B]

## P1778 STEP MOTOR

### Description

INFOID:000000009752638

- The step motor's 4 aspects of ON/OFF change according to the signal from TCM. As a result, the flow of line pressure to primary pulley is changed and pulley ratio is controlled.
- This diagnosis item is detected when electrical system is OK, but mechanical system is NG.
- This diagnosis item is detected when the state of the changing the speed mechanism in unit does not operate normally.

### DTC Logic

INFOID:000000009752639

### DTC DETECTION LOGIC

DTC	Trouble diagnosis name	DTC detection condition	Possible causes
P1778	Step Motor Circuit Intermittent	There is a large difference between the primary pulley speed sensor value and the primary pulley speed estimated from the secondary speed sensor value, or there is a large difference between the target pulley ratio and actual pulley ratio.	Step motor

### DTC CONFIRMATION PROCEDURE

#### CAUTION:

- Always drive vehicle at a safe speed.
- Before starting "DTC CONFIRMATION PROCEDURE", confirm "Hi" or "Mid" or "Low" fixation by "PRI SPEED" and "VEHICLE SPEED" on "DATA MONITOR MODE".
- If hi-gear fixation occurred, go to [TM-288, "Diagnosis Procedure"](#).

#### 1. PREPARATION BEFORE WORK

If another "DTC CONFIRMATION PROCEDURE" occurs just before, turn ignition switch OFF and wait for at least 10 seconds, then perform the next test.

>> GO TO 2.

#### 2. CHECK DTC DETECTION

##### With CONSULT

1. Start the engine.
2. Select "Data Monitor" in "TRANSMISSION".
3. Select "RANGE", "ATF TEMP SEN", "ACC PEDAL OPEN", "PRI SPEED" and "VEHICLE SPEED".
4. Drive the vehicle.
5. Maintain the following condition for 5 seconds or more.

RANGE	: "D" position
ATF TEMP SEN	: 2.03 – 0.16 V
ACC PEDAL OPEN	: 1.0/8 or more
PRI SPEED	: 1,000 rpm or more
VEHICLE SPEED	: 10 km/h (7 MPH) or more

6. Stop the vehicle.
7. Select "Self Diagnostic Results" in "TRANSMISSION".

##### With GST

Follow the procedure "With CONSULT".

##### Is "P1778" detected?

- YES >> Go to [TM-288, "Diagnosis Procedure"](#).  
 NO >> INSPECTION END

## Diagnosis Procedure

### 1. CHECK STEP MOTOR SYSTEM

Check step motor system. Refer to [TM-284, "DTC Logic"](#).

Is the inspection result normal?

YES >> GO TO 2.

NO >> Repair or replace damaged parts. Refer to [TM-221, "Inspection and Judgment"](#).

### 2. CHECK PRIMARY SPEED SENSOR SYSTEM

Check primary speed sensor system. Refer to [TM-239, "DTC Logic"](#).

Is the inspection result normal?

YES >> GO TO 3.

NO >> Repair or replace damaged parts.

### 3. CHECK SECONDARY SPEED SENSOR SYSTEM

Check secondary speed sensor system. Refer to [TM-242, "DTC Logic"](#).

Is the inspection result normal?

YES >> GO TO 4.

NO >> Repair or replace damaged parts.

### 4. CHECK INTERMITTENT INCIDENT

Refer to [GI-46, "Intermittent Incident"](#).

Is the inspection result normal?

YES >> Replace transaxle assembly. Refer to [TM-339, "2WD : Removal and Installation"](#) (2WD) or [TM-342, "AWD : Removal and Installation"](#) (AWD).

NO >> Repair or replace damaged parts.



# SHIFT POSITION INDICATOR CIRCUIT

< DTC/CIRCUIT DIAGNOSIS >

[CVT: RE0F10B]

## SHIFT POSITION INDICATOR CIRCUIT

### Description

INFOID:000000009752641

- TCM sends position indicator signals to combination meter by CAN communication line.
- Manual mode switch position is indicated on shift position indicator.

### Component Function Check

INFOID:000000009752642

#### 1. CHECK SHIFT POSITION INDICATOR

##### **CAUTION:**

**Always drive vehicle at a safe speed.**

1. Start engine.
2. Check if correct selector lever position ("P", "N", "R" or "D") is displayed as selector lever is moved into each position.
3. Drive vehicle in the manual mode, and confirm that the actual gear position and the meter's indication of the position mutually coincide when the selector lever is shifted to the "UP (+ side)" or "DOWN (- side)" side [1st ↔ 6th (8th\*) gear].  
\*: NISMO RS models

Is the inspection result normal?

YES >> INSPECTION END

NO >> Go to [TM-289, "Diagnosis Procedure"](#).

### Diagnosis Procedure

INFOID:000000009752643

#### 1. CHECK INPUT SIGNALS

##### **With CONSULT**

1. Start engine.
2. Check if correct selector lever position ("P", "N", "R" or "D") is displayed as selector lever is moved into each position.
3. Select "RENGE" on "DATA MONITOR" and read out the value.
4. Drive vehicle in the manual mode, and confirm that the actual gear position and the meter's indication of the position mutually coincide when the selector lever is shifted to the "UP (+ side)" or "DOWN (- side)" side [1st ↔ 6th (8th\*) gear].  
\*: NISMO RS models

Is the inspection result normal?

YES >> INSPECTION END

NO - 1 >> The actual gear position does not change, or shifting into the manual mode is not possible (no gear shifting in the manual mode possible). Or the shift position indicator is not indicated.

- Check manual mode switch. Refer to [TM-263, "Component Inspection \(Manual Mode Switch\)"](#).
- Check CVT main system (Fail-safe function actuated).
- Perform "SELF-DIAG RESULTS" mode for "TRANSMISSION". Refer to [TM-185, "CONSULT Function"](#).

NO - 2 >> The actual gear position changes, but the shift position indicator is not indicated.

- Perform "SELF-DIAG RESULTS" mode for "TRANSMISSION". Refer to [TM-185, "CONSULT Function"](#).

NO - 3 >> The actual gear position and the indication on the shift position indicator do not coincide.

- Perform "SELF-DIAG RESULTS" mode for "TRANSMISSION". Refer to [TM-185, "CONSULT Function"](#).

NO - 4 >> Only a specific position or positions is/are not indicated on the shift position indicator.

- Check the combination meter. Refer to [MWI-43, "Work flow"](#).

# SHIFT LOCK SYSTEM

< DTC/CIRCUIT DIAGNOSIS >

[CVT: RE0F10B]

## SHIFT LOCK SYSTEM

### Component Function Check

INFOID:000000009752644

#### 1. CHECK SHIFT LOCK OPERATION (PART 1)

1. Turn ignition switch ON.
2. Shift the selector lever to "P" position.
3. Attempt to shift the selector lever to any other than position with the brake pedal released.

Can the selector lever be shifted to any other position?

- YES >> Go to [TM-290, "Diagnosis Procedure"](#).  
NO >> GO TO 2.

#### 2. CHECK SHIFT LOCK OPERATION (PART 2)

Attempt to shift the selector lever to any other than position with the brake pedal depressed.

Can the selector lever be shifted to any other position?

- YES >> INSPECTION END  
NO >> Go to [TM-290, "Diagnosis Procedure"](#).

### Diagnosis Procedure

INFOID:000000009752645

#### 1. CHECK POWER SOURCE

1. Turn ignition switch OFF.
2. Disconnect stop lamp switch connector
3. Turn ignition switch ON.
4. Check the voltage between the stop lamp switch harness connector terminal and ground.

+		-	Voltage
Stop lamp switch			
Connector	Terminal		
E102	3	Ground	Battery voltage

Is the inspection result normal?

- YES >> GO TO 2.  
NO >> GO TO 9.

#### 2. CHECK STOP LAMP SWITCH (PART 1)

Check stop lamp switch. Refer to [TM-293, "Component Inspection \(Stop Lamp Switch\)"](#).

Is the inspection result normal?

- YES >> GO TO 3.  
NO >> GO TO 10.

#### 3. CHECK CIRCUIT BETWEEN STOP LAMP SWITCH AND CVT SHIFT SELECTOR (PART 1)

1. Disconnect CVT shift selector connector
2. Check the continuity between the stop lamp switch harness connector terminal and the CVT shift selector harness connector terminal.

Stop lamp switch		CVT shift selector		Continuity
Connector	Terminal	Connector	Terminal	
E102	4	M57	3	Existed

Is the inspection result normal?

- YES >> GO TO 4.  
NO >> Repair or replace the malfunctioning parts.

#### 4. CHECK CIRCUIT BETWEEN STOP LAMP SWITCH AND CVT SHIFT SELECTOR (PART 2)

Check the continuity between the stop lamp switch harness connector terminal and ground.

# SHIFT LOCK SYSTEM

< DTC/CIRCUIT DIAGNOSIS >

[CVT: RE0F10B]

Stop lamp switch		—	Continuity
Connector	Terminal		
E102	4	Ground	Not existed

Is the inspection result normal?

YES >> GO TO 5.

NO >> Repair or replace the malfunctioning parts.

## 5. CHECK GROUND CIRCUIT

Check the continuity between the CVT shift selector harness connector terminal and ground.

CVT shift selector		—	Continuity
Connector	Terminal		
M57	4	Ground	Existed

Is the inspection result normal?

YES >> GO TO 6.

NO >> Repair or replace the malfunctioning parts.

## 6. CHECK PART POSITION SWITCH

1. Disconnect park position switch connector.
2. Check park position switch. Refer to [TM-292, "Component Inspection \(Park Position Switch\)"](#).

Is the inspection result normal?

YES >> GO TO 7.

NO >> Repair or replace the malfunctioning parts.

## 7. CHECK SHIFT LOCK SOLENOID

1. Disconnect shift lock solenoid connector.
2. Check shift lock solenoid. Refer to [TM-292, "Component Inspection \(Shift Lock Solenoid\)"](#).

Is the inspection result normal?

YES >> GO TO 8.

NO >> Repair or replace the malfunctioning parts.

## 8. CHECK CVT SHIFT SELECTOR HARNESS

Check CVT shift selector harness. Refer to [TM-292, "Component Inspection \(CVT Shift Selector Harness\)"](#).

Is the inspection result normal?

YES >> Check intermittent incident. Refer to [GI-46, "Intermittent Incident"](#).

NO >> Repair or replace the malfunctioning parts.

## 9. DETECT MALFUNCTIONING ITEM

Check the following items:

- Open or short circuit in harness between ignition switch and stop lamp switch connector terminal 3. Refer to [PG-41, "Wiring Diagram - IGNITION POWER SUPPLY -"](#).
- Ignition switch
- 10A fuse [No.3, fuse block (J/B)]. Refer to [PG-62, "Fuse, Connector and Terminal Arrangement"](#).

Is the inspection result normal?

YES >> Check intermittent incident. Refer to [GI-46, "Intermittent Incident"](#).

NO >> Repair or replace the malfunctioning parts.

## 10. CHECK INSTALLATION POSITION OF STOP LAMP SWITCH

Adjust stop lamp switch position. Refer to [BR-7, "Inspection and Adjustment"](#).

>> GO TO 11.

## 11. CHECK STOP LAMP SWITCH (PART 2)

Check stop lamp switch. Refer to [TM-293, "Component Inspection \(Stop Lamp Switch\)"](#).

# SHIFT LOCK SYSTEM

[CVT: RE0F10B]

< DTC/CIRCUIT DIAGNOSIS >

Is the inspection result normal?

YES >> INSPECTION END

NO >> Repair or replace the malfunctioning parts.

## Component Inspection (Shift Lock Solenoid)

INFOID:000000009752646

### 1.CHECK SHIFT LOCK SOLENOID

Apply voltage to terminals of shift lock solenoid connector and check that shift lock solenoid is activated.

#### **CAUTION:**

- Connect the fuse between the terminals when applying the voltage.
- Never cause shorting between terminals.

Shift lock solenoid		Condition	Status
+ (fuse)	-		
Terminal			
1	2	Apply battery voltage between terminals 1 and 2.	Shift lock solenoid operates

Is the inspection result normal?

YES >> INSPECTION END

NO >> Replace the shift lock unit. Refer to [TM-308. "Disassembly and Assembly"](#).

## Component Inspection (Park Position Switch)

INFOID:000000009752647

### 1.CHECK PARK POSITION SWITCH

Check the continuity between park position switch connector terminals.

#### **CAUTION:**

- Connect the fuse between the terminals when applying the voltage.
- Never cause shorting between terminals.

Park position switch	Condition	Continuity
Terminal		
1 - 2	Shift the selector lever to "P" position.	Existed
	Other than above	Not existed

Is the inspection result normal?

YES >> INSPECTION END

NO >> Replace the park position switch. Refer to [TM-308. "Disassembly and Assembly"](#).

## Component Inspection (CVT Shift Selector Harness)

INFOID:000000009752648

### 1.CHECK CVT SHIFT SELECTOR HARNESS (PART 1)

Check the continuity between the CVT shift selector harness connector terminal and the shift lock solenoid harness connector terminal.

CVT shift selector		Shift lock solenoid		Continuity
Connector	Terminal	Connector	Terminal	
M324	3	M326	1	Existed

Is the inspection result normal?

YES >> GO TO 2.

NO >> Replace the CVT shift selector harness. Refer to [TM-308. "Disassembly and Assembly"](#).

### 2.CHECK CVT SHIFT SELECTOR HARNESS (PART 2)

Check the continuity between the shift lock solenoid harness connector terminal and the park position switch harness connector terminal.

# SHIFT LOCK SYSTEM

< DTC/CIRCUIT DIAGNOSIS >

[CVT: RE0F10B]

Shift lock solenoid		Park position switch		Continuity
Connector	Terminal	Connector	Terminal	
M326	2	M325	1	Existed

Is the inspection result normal?

YES >> GO TO 3.

NO >> Replace the CVT shift selector harness. Refer to [TM-308, "Disassembly and Assembly"](#).

## 3.CHECK CVT SHIFT SELECTOR HARNESS (PART 3)

Check the continuity between the park switch harness connector terminal and the CVT shift selector harness connector terminal.

Park switch		CVT shift selector		Continuity
Connector	Terminal	Connector	Terminal	
M325	2	M324	4	Existed

Is the inspection result normal?

YES >> GO TO 4.

NO >> Replace the CVT shift selector harness. Refer to [TM-308, "Disassembly and Assembly"](#).

## 4.CHECK CVT SHIFT SELECTOR HARNESS (PART 4)

Check harness cladding CVT shift selector harness for damage.

Is the inspection result normal?

YES >> INSPECTION END

NO >> Replace the CVT shift selector harness. Refer to [TM-308, "Disassembly and Assembly"](#).

## Component Inspection (Stop Lamp Switch)

INFOID:000000009752649

### 1.CHECK STOP LAMP SWITCH

Check the continuity between the stop lamp switch connector terminals.

Stop lamp switch	Condition	Continuity
Terminal		
3 – 4	Depressed brake pedal	Existed
	Released brake pedal	Not existed

Is the inspection result normal?

YES >> INSPECTION END

NO >> Replace stop lamp switch. Refer to [BR-18, "Exploded View"](#).

# SYSTEM SYMPTOM

< SYMPTOM DIAGNOSIS >

[CVT: RE0F10B]

## SYMPTOM DIAGNOSIS

### SYSTEM SYMPTOM

#### Symptom Table

INFOID:000000009752650

The diagnostics item numbers show the sequence for inspection. Inspect in order from item 1.

No.	Item	Symptom	Condition	Diagnostic Item	Reference
1	Shift Shock	Large shock. ("N"→ "D" position)	ON vehicle	1. Engine idle speed	<a href="#">EC-136</a>
				2. Engine speed signal	<a href="#">TM-245</a>
				3. Accelerator pedal position sensor	<a href="#">TM-275</a>
				4. CVT position	<a href="#">TM-226</a>
				5. CVT fluid temperature sensor	<a href="#">TM-236</a>
				6. CAN communication line	<a href="#">TM-228</a>
				7. CVT fluid level and state	<a href="#">TM-305</a>
				8. Line pressure test	<a href="#">TM-221</a>
				9. Torque converter clutch solenoid valve	<a href="#">TM-246</a>
				10. Lock-up select solenoid valve	<a href="#">TM-282</a>
				11. Transmission range switch	<a href="#">TM-233</a>
				12. Control valve	<a href="#">TM-322</a>
			OFF vehicle	13. Forward clutch	<a href="#">TM-342</a>
2	Shift Shock	Large shock. ("N"→ "R" position)	ON vehicle	1. Engine idle speed	<a href="#">EC-136</a>
				2. Engine speed signal	<a href="#">TM-245</a>
				3. Accelerator pedal position sensor	<a href="#">TM-275</a>
				4. CVT position	<a href="#">TM-226</a>
				5. CVT fluid temperature sensor	<a href="#">TM-236</a>
				6. CAN communication line	<a href="#">TM-228</a>
				7. CVT fluid level and state	<a href="#">TM-305</a>
				8. Line pressure test	<a href="#">TM-221</a>
				9. Torque converter clutch solenoid valve	<a href="#">TM-246</a>
				10. Lock-up select solenoid valve	<a href="#">TM-282</a>
				11. Transmission range switch	<a href="#">TM-233</a>
				12. Control valve	<a href="#">TM-322</a>
			OFF vehicle	13. Reverse brake	<a href="#">TM-342</a>
3	Shift Shock	Shock is too large for lock-up.	ON vehicle	1. CVT position	<a href="#">TM-226</a>
				2. Engine speed signal	<a href="#">TM-245</a>
				3. CAN communication line	<a href="#">TM-228</a>
				4. CVT fluid level and state	<a href="#">TM-305</a>
				5. Control valve	<a href="#">TM-322</a>
			OFF vehicle	6. Torque converter	<a href="#">TM-346</a>

# SYSTEM SYMPTOM

< SYMPTOM DIAGNOSIS >

[CVT: RE0F10B]

No.	Item	Symptom	Condition	Diagnostic Item	Reference
4	Slips/Will Not Engage	Vehicle cannot be started from "D" position.	ON vehicle	1. CVT fluid level and state	<a href="#">TM-305</a>
				2. CVT position	<a href="#">TM-226</a>
				3. CAN communication line	<a href="#">TM-228</a>
				4. Line pressure test	<a href="#">TM-221</a>
				5. Stall test	<a href="#">TM-219</a>
				6. Step motor	<a href="#">TM-284</a>
				7. Primary speed sensor	<a href="#">TM-239</a>
				8. Secondary speed sensor	<a href="#">TM-242</a>
				9. Accelerator pedal position sensor	<a href="#">TM-275</a>
				10. CVT fluid temperature sensor	<a href="#">TM-236</a>
				11. Secondary pressure sensor	<a href="#">TM-265</a>
				12. Power supply	<a href="#">TM-272</a>
				13. Control valve	<a href="#">TM-322</a>
			OFF vehicle	14. Oil pump assembly	<a href="#">TM-342</a>
				15. Forward clutch	
				16. Parking components	
5	Slips/Will Not Engage	Vehicle cannot be started from "R" position.	ON vehicle	1. CVT fluid level and state	<a href="#">TM-305</a>
				2. CVT position	<a href="#">TM-226</a>
				3. CAN communication line	<a href="#">TM-228</a>
				4. Line pressure test	<a href="#">TM-221</a>
				5. Stall test	<a href="#">TM-219</a>
				6. Step motor	<a href="#">TM-284</a>
				7. Primary speed sensor	<a href="#">TM-239</a>
				8. Secondary speed sensor	<a href="#">TM-242</a>
				9. Accelerator pedal position sensor	<a href="#">TM-275</a>
				10. CVT fluid temperature sensor	<a href="#">TM-236</a>
				11. Secondary pressure sensor	<a href="#">TM-265</a>
				12. Power supply	<a href="#">TM-272</a>
				13. Control valve	<a href="#">TM-322</a>
			OFF vehicle	14. Oil pump assembly	<a href="#">TM-342</a>
				15. Reverse brake	
				16. Parking components	

A  
B  
C  
TM  
E  
F  
G  
H  
I  
J  
K  
L  
M  
N  
O  
P

# SYSTEM SYMPTOM

< SYMPTOM DIAGNOSIS >

[CVT: RE0F10B]

No.	Item	Symptom	Condition	Diagnostic Item	Reference
6	Slips/Will Not Engage	Does not lock-up.	ON vehicle	1. CVT fluid level and state	<a href="#">TM-305</a>
				2. Line pressure test	<a href="#">TM-221</a>
				3. Engine speed signal	<a href="#">TM-245</a>
				4. Primary speed sensor	<a href="#">TM-239</a>
				5. Torque converter clutch solenoid valve	<a href="#">TM-246</a>
				6. CAN communication line	<a href="#">TM-228</a>
				7. Stall test	<a href="#">TM-219</a>
				8. Step motor	<a href="#">TM-284</a>
				9. Transmission range switch	<a href="#">TM-233</a>
				10. Lock-up select solenoid valve	<a href="#">TM-282</a>
				11. CVT fluid temperature sensor	<a href="#">TM-236</a>
				12. Secondary speed sensor	<a href="#">TM-242</a>
				13. Secondary pressure sensor	<a href="#">TM-265</a>
				14. Control valve	<a href="#">TM-322</a>
			OFF vehicle	15. Torque converter	<a href="#">TM-346</a>
				16. Oil pump assembly	<a href="#">TM-342</a>
7	Slips/Will Not Engage	Does not hold lock-up condition.	ON vehicle	1. CVT fluid level and state	<a href="#">TM-305</a>
				2. Line pressure test	<a href="#">TM-221</a>
				3. Engine speed signal	<a href="#">TM-245</a>
				4. Primary speed sensor	<a href="#">TM-239</a>
				5. Torque converter clutch solenoid valve	<a href="#">TM-246</a>
				6. CAN communication line	<a href="#">TM-228</a>
				7. Stall test	<a href="#">TM-219</a>
				8. Step motor	<a href="#">TM-284</a>
				9. Transmission range switch	<a href="#">TM-233</a>
				10. Lock-up select solenoid valve	<a href="#">TM-282</a>
				11. CVT fluid temperature sensor	<a href="#">TM-236</a>
				12. Secondary speed sensor	<a href="#">TM-242</a>
				13. Secondary pressure sensor	<a href="#">TM-265</a>
				14. Control valve	<a href="#">TM-322</a>
			OFF vehicle	15. Torque converter	<a href="#">TM-346</a>
				16. Oil pump assembly	<a href="#">TM-342</a>



# SYSTEM SYMPTOM

< SYMPTOM DIAGNOSIS >

[CVT: RE0F10B]

No.	Item	Symptom	Condition	Diagnostic Item	Reference
8		Lock-up is not released.	ON vehicle	1. CVT fluid level and state	<a href="#">TM-305</a>
				2. Line pressure test	<a href="#">TM-221</a>
				3. Engine speed signal	<a href="#">TM-245</a>
				4. Primary speed sensor	<a href="#">TM-239</a>
				5. Torque converter clutch solenoid valve	<a href="#">TM-246</a>
				6. CAN communication line	<a href="#">TM-228</a>
				7. Stall test	<a href="#">TM-219</a>
				8. Control valve	<a href="#">TM-322</a>
			OFF vehicle	9. Torque converter	<a href="#">TM-346</a>
				10. Oil pump assembly	<a href="#">TM-342</a>
9	Slips/Will Not Engage	With selector lever in "D" position, acceleration is extremely poor.	ON vehicle	1. CVT fluid level and state	<a href="#">TM-305</a>
				2. Line pressure test	<a href="#">TM-221</a>
				3. Stall test	<a href="#">TM-219</a>
				4. Accelerator pedal position sensor	<a href="#">TM-275</a>
				5. CAN communication line	<a href="#">TM-228</a>
				6. Transmission range switch	<a href="#">TM-233</a>
				7. CVT position	<a href="#">TM-226</a>
				8. Step motor	<a href="#">TM-284</a>
				9. Primary speed sensor	<a href="#">TM-239</a>
				10. Secondary speed sensor	<a href="#">TM-242</a>
				11. Accelerator pedal position sensor	<a href="#">TM-275</a>
				12. Secondary pressure sensor	<a href="#">TM-265</a>
				13. CVT fluid temperature sensor	<a href="#">TM-236</a>
				14. Power supply	<a href="#">TM-272</a>
				15. Control valve	<a href="#">TM-322</a>
			OFF vehicle	16. Torque converter	<a href="#">TM-346</a>
				17. Oil pump assembly	<a href="#">TM-342</a>
				18. Forward clutch	

A  
B  
C  
TM  
E  
F  
G  
H  
I  
J  
K  
L  
M  
N  
O  
P

# SYSTEM SYMPTOM

< SYMPTOM DIAGNOSIS >

[CVT: RE0F10B]

No.	Item	Symptom	Condition	Diagnostic Item	Reference
10	Slips/Will Not Engage	With selector lever in "R" position, acceleration is extremely poor.	ON vehicle	1. CVT fluid level and state	<a href="#">TM-305</a>
				2. Line pressure test	<a href="#">TM-221</a>
				3. Stall test	<a href="#">TM-219</a>
				4. Accelerator pedal position sensor	<a href="#">TM-275</a>
				5. CAN communication line	<a href="#">TM-228</a>
				6. Transmission range switch	<a href="#">TM-233</a>
				7. CVT position	<a href="#">TM-226</a>
				8. Step motor	<a href="#">TM-284</a>
				9. Primary speed sensor	<a href="#">TM-239</a>
				10. Secondary speed sensor	<a href="#">TM-242</a>
				11. Accelerator pedal position sensor	<a href="#">TM-275</a>
				12. Secondary pressure sensor	<a href="#">TM-265</a>
				13. CVT fluid temperature sensor	<a href="#">TM-236</a>
				14. Power supply	<a href="#">TM-272</a>
				15. Control valve	<a href="#">TM-322</a>
			OFF vehicle	16. Torque converter	<a href="#">TM-346</a>
				17. Oil pump assembly	<a href="#">TM-342</a>
				18. Reverse brake	
11	Slips at lock-up.		ON vehicle	1. CVT fluid level and state	<a href="#">TM-305</a>
				2. Line pressure test	<a href="#">TM-221</a>
				3. Engine speed signal	<a href="#">TM-245</a>
				4. Primary speed sensor	<a href="#">TM-239</a>
				5. Torque converter clutch solenoid valve	<a href="#">TM-246</a>
				6. CAN communication line	<a href="#">TM-228</a>
				7. Stall test	<a href="#">TM-219</a>
				8. Step motor	<a href="#">TM-284</a>
				9. Transmission range switch	<a href="#">TM-233</a>
				10. Lock-up select solenoid valve	<a href="#">TM-282</a>
				11. CVT fluid temperature sensor	<a href="#">TM-236</a>
				12. Secondary speed sensor	<a href="#">TM-242</a>
				13. Secondary pressure sensor	<a href="#">TM-265</a>
				14. Control valve	<a href="#">TM-322</a>
			OFF vehicle	15. Torque converter	<a href="#">TM-346</a>
				16. Oil pump assembly	<a href="#">TM-342</a>

# SYSTEM SYMPTOM

< SYMPTOM DIAGNOSIS >

[CVT: RE0F10B]

No.	Item	Symptom	Condition	Diagnostic Item	Reference	
12	Other	No creep at all.	ON vehicle	1. CVT fluid level and state	<a href="#">TM-305</a>	A
				2. Line pressure test	<a href="#">TM-221</a>	
				3. Accelerator pedal position sensor	<a href="#">TM-275</a>	B
				4. Transmission range switch	<a href="#">TM-233</a>	
				5. CAN communication line	<a href="#">TM-228</a>	
				6. Stall test	<a href="#">TM-219</a>	C
				7. CVT position	<a href="#">TM-226</a>	
				8. Step motor	<a href="#">TM-284</a>	TM
				9. Primary speed sensor	<a href="#">TM-239</a>	
				10. Secondary speed sensor	<a href="#">TM-242</a>	
				11. Accelerator pedal position sensor	<a href="#">TM-275</a>	E
				12. CVT fluid temperature sensor	<a href="#">TM-236</a>	
				13. Secondary pressure sensor	<a href="#">TM-265</a>	F
				14. Power supply	<a href="#">TM-272</a>	
				15. Control valve	<a href="#">TM-322</a>	
			OFF vehicle	16. Torque converter	<a href="#">TM-346</a>	G
				17. Oil pump assembly	<a href="#">TM-342</a>	
				18. Gear system		
				19. Forward clutch		
				20. Reverse brake		
13	Other	Vehicle cannot run in all positions.	ON vehicle	1. CVT fluid level and state	<a href="#">TM-305</a>	I
				2. Line pressure test	<a href="#">TM-221</a>	
				3. Transmission range switch	<a href="#">TM-233</a>	
				4. Stall test	<a href="#">TM-219</a>	J
				5. CVT position	<a href="#">TM-226</a>	
				6. Step motor	<a href="#">TM-284</a>	
				7. Primary speed sensor	<a href="#">TM-239</a>	K
				8. Secondary speed sensor	<a href="#">TM-242</a>	
				9. Accelerator pedal position sensor	<a href="#">TM-275</a>	L
				10. CVT fluid temperature sensor	<a href="#">TM-236</a>	
				11. Secondary pressure sensor	<a href="#">TM-265</a>	M
				12. Power supply	<a href="#">TM-272</a>	
				13. Control valve	<a href="#">TM-322</a>	
			OFF vehicle	14. Torque converter	<a href="#">TM-346</a>	N
				15. Oil pump assembly	<a href="#">TM-342</a>	
				16. Gear system		
				17. Forward clutch		
				18. Reverse brake		
				19. Parking components		
			P			

# SYSTEM SYMPTOM

< SYMPTOM DIAGNOSIS >

[CVT: RE0F10B]

No.	Item	Symptom	Condition	Diagnostic Item	Reference
14	Other	With selector lever in "D" position, driving is not possible.	ON vehicle	1. CVT fluid level and state	<a href="#">TM-305</a>
				2. Line pressure test	<a href="#">TM-221</a>
				3. Transmission range switch	<a href="#">TM-233</a>
				4. Stall test	<a href="#">TM-219</a>
				5. CVT position	<a href="#">TM-226</a>
				6. Step motor	<a href="#">TM-284</a>
				7. Primary speed sensor	<a href="#">TM-239</a>
				8. Secondary speed sensor	<a href="#">TM-242</a>
				9. Accelerator pedal position sensor	<a href="#">TM-275</a>
				10. CVT fluid temperature sensor	<a href="#">TM-236</a>
				11. Secondary pressure sensor	<a href="#">TM-265</a>
				12. Power supply	<a href="#">TM-272</a>
				13. Control valve	<a href="#">TM-322</a>
			OFF vehicle	14. Torque converter	<a href="#">TM-346</a>
				15. Oil pump assembly	<a href="#">TM-342</a>
				16. Gear system	
				17. Forward clutch	
				18. Parking components	
15	Other	With selector lever in "R" position, driving is not possible.	ON vehicle	1. CVT fluid level and state	<a href="#">TM-305</a>
				2. Line pressure test	<a href="#">TM-221</a>
				3. Transmission range switch	<a href="#">TM-233</a>
				4. Stall test	<a href="#">TM-219</a>
				5. CVT position	<a href="#">TM-226</a>
				6. Step motor	<a href="#">TM-284</a>
				7. Primary speed sensor	<a href="#">TM-239</a>
				8. Secondary speed sensor	<a href="#">TM-242</a>
				9. Accelerator pedal position sensor	<a href="#">TM-275</a>
				10. CVT fluid temperature sensor	<a href="#">TM-236</a>
				11. Secondary pressure sensor	<a href="#">TM-265</a>
				12. Power supply	<a href="#">TM-272</a>
				13. Control valve	<a href="#">TM-322</a>
			OFF vehicle	14. Torque converter	<a href="#">TM-346</a>
				15. Oil pump assembly	<a href="#">TM-342</a>
				16. Gear system	
				17. Reverse brake	
				18. Parking components	

# SYSTEM SYMPTOM

< SYMPTOM DIAGNOSIS >

[CVT: RE0F10B]

No.	Item	Symptom	Condition	Diagnostic Item	Reference
16	Other	Judder occurs during lock-up.	ON vehicle	1. CVT fluid level and state	<a href="#">TM-305</a>
				2. Engine speed signal	<a href="#">TM-245</a>
				3. Primary speed sensor	<a href="#">TM-239</a>
				4. Secondary speed sensor	<a href="#">TM-242</a>
				5. Accelerator pedal position sensor	<a href="#">TM-275</a>
				6. CAN communication line	<a href="#">TM-228</a>
				7. Torque converter clutch solenoid valve	<a href="#">TM-246</a>
				8. Control valve	<a href="#">TM-322</a>
			OFF vehicle	9. Torque converter	<a href="#">TM-346</a>
17	Other	Strange noise in "D" position.	ON vehicle	1. CVT fluid level and state	<a href="#">TM-305</a>
				2. Engine speed signal	<a href="#">TM-245</a>
				3. CAN communication line	<a href="#">TM-228</a>
				4. Control valve	<a href="#">TM-322</a>
			OFF vehicle	5. Torque converter	<a href="#">TM-346</a>
				6. Oil pump assembly	<a href="#">TM-342</a>
				7. Gear system	
				8. Forward clutch	
				9. Bearing	
18	Other	Strange noise in "R" position.	ON vehicle	1. CVT fluid level and state	<a href="#">TM-305</a>
				2. Engine speed signal	<a href="#">TM-245</a>
				3. CAN communication line	<a href="#">TM-228</a>
				4. Control valve	<a href="#">TM-322</a>
			OFF vehicle	5. Torque converter	<a href="#">TM-346</a>
				6. Oil pump assembly	<a href="#">TM-342</a>
				7. Gear system	
				8. Reverse brake	
19	Other	Strange noise in "N" position.	ON vehicle	1. CVT fluid level and state	<a href="#">TM-305</a>
				2. Engine speed signal	<a href="#">TM-245</a>
				3. CAN communication line	<a href="#">TM-228</a>
				4. Control valve	<a href="#">TM-322</a>
			OFF vehicle	5. Torque converter	<a href="#">TM-346</a>
				6. Oil pump assembly	<a href="#">TM-342</a>
				7. Gear system	

A  
B  
C  
TM  
E  
F  
G  
H  
I  
J  
K  
L  
M  
N  
O  
P

# SYSTEM SYMPTOM

< SYMPTOM DIAGNOSIS >

[CVT: RE0F10B]

No.	Item	Symptom	Condition	Diagnostic Item	Reference
20		Vehicle does not decelerate by engine brake.	ON vehicle	1. CVT fluid level and state	<a href="#">TM-305</a>
				2. CVT position	<a href="#">TM-226</a>
				3. CAN communication line	<a href="#">TM-228</a>
				4. Step motor	<a href="#">TM-284</a>
				5. Primary speed sensor	<a href="#">TM-239</a>
				6. Secondary speed sensor	<a href="#">TM-242</a>
				7. Line pressure test	<a href="#">TM-221</a>
				8. Engine speed signal	<a href="#">TM-245</a>
				9. Accelerator pedal position sensor	<a href="#">TM-275</a>
				10. Control valve	<a href="#">TM-342</a>
21	Other	Maximum speed low.	ON vehicle	1. CVT fluid level and state	<a href="#">TM-305</a>
				2. Line pressure test	<a href="#">TM-221</a>
				3. Accelerator pedal position sensor	<a href="#">TM-275</a>
				4. CAN communication line	<a href="#">TM-228</a>
				5. Stall test	<a href="#">TM-219</a>
				6. Step motor	<a href="#">TM-284</a>
				7. Primary speed sensor	<a href="#">TM-239</a>
				8. Secondary speed sensor	<a href="#">TM-242</a>
				9. Secondary pressure sensor	<a href="#">TM-265</a>
				10. CVT fluid temperature sensor	<a href="#">TM-236</a>
				11. Control valve	<a href="#">TM-322</a>
			OFF vehicle	12. Torque converter	<a href="#">TM-346</a>
				13. Oil pump assembly	<a href="#">TM-342</a>
				14. Gear system	
				15. Forward clutch	
22		With selector lever in "P" position, vehicle does not enter parking condition or, with selector lever in another position, parking condition is not cancelled.	ON vehicle	1. Transmission range switch	<a href="#">TM-233</a>
				2. CVT position	<a href="#">TM-226</a>
			OFF vehicle	3. Parking components	<a href="#">TM-342</a>
23		Vehicle runs with CVT in "P" position.	ON vehicle	1. Transmission range switch	<a href="#">TM-233</a>
				2. CVT fluid level and state	<a href="#">TM-305</a>
				3. CVT position	<a href="#">TM-226</a>
				4. Control valve	<a href="#">TM-322</a>
			OFF vehicle	5. Parking components	<a href="#">TM-342</a>
				6. Gear system	

# SYSTEM SYMPTOM

< SYMPTOM DIAGNOSIS >

[CVT: RE0F10B]

No.	Item	Symptom	Condition	Diagnostic Item	Reference
24	Other	Vehicle runs with CVT in "N" position.	ON vehicle	1. Transmission range switch	<a href="#">TM-233</a>
				2. CVT fluid level and state	<a href="#">TM-305</a>
				3. CVT position	<a href="#">TM-226</a>
				4. Control valve	<a href="#">TM-322</a>
			OFF vehicle	5. Gear system	<a href="#">TM-342</a>
				6. Forward clutch	
				7. Reverse brake	
25	Other	Engine stall.	ON vehicle	1. CVT fluid level and state	<a href="#">TM-305</a>
				2. Engine speed signal	<a href="#">TM-245</a>
				3. Primary speed sensor	<a href="#">TM-239</a>
				4. Torque converter clutch solenoid valve	<a href="#">TM-246</a>
				5. CAN communication line	<a href="#">TM-228</a>
				6. Stall test	<a href="#">TM-219</a>
				7. Secondary pressure sensor	<a href="#">TM-265</a>
				8. Control valve	<a href="#">TM-322</a>
			OFF vehicle	9. Torque converter	<a href="#">TM-346</a>
26	Other	Engine stalls when selector lever shifted "N"→"D" or "R".	ON vehicle	1. CVT fluid level and state	<a href="#">TM-305</a>
				2. Engine speed signal	<a href="#">TM-245</a>
				3. Primary speed sensor	<a href="#">TM-239</a>
				4. Torque converter clutch solenoid valve	<a href="#">TM-246</a>
				5. CAN communication line	<a href="#">TM-228</a>
				6. Stall test	<a href="#">TM-219</a>
				7. Control valve	<a href="#">TM-322</a>
			OFF vehicle	8. Torque converter	<a href="#">TM-346</a>
27	Other	Engine speed does not return to idle.	ON vehicle	1. CVT fluid level and state	<a href="#">TM-305</a>
				2. Accelerator pedal position sensor	<a href="#">TM-275</a>
				3. Secondary speed sensor	<a href="#">TM-242</a>
				4. CAN communication line	<a href="#">TM-228</a>
				5. Control valve	<a href="#">TM-342</a>

A  
B  
C  
TM  
E  
F  
G  
H  
I  
J  
K  
L  
M  
N  
O  
P

# SYSTEM SYMPTOM

< SYMPTOM DIAGNOSIS >

[CVT: RE0F10B]

No.	Item	Symptom	Condition	Diagnostic Item	Reference
28		CVT does not shift	ON vehicle	1. CVT fluid level and state	<a href="#">TM-305</a>
				2. CVT position	<a href="#">TM-226</a>
				3. Line pressure test	<a href="#">TM-221</a>
				4. Engine speed signal	<a href="#">TM-245</a>
				5. Accelerator pedal position sensor	<a href="#">TM-275</a>
				6. CAN communication line	<a href="#">TM-228</a>
				7. Primary speed sensor	<a href="#">TM-239</a>
				8. Secondary speed sensor	<a href="#">TM-242</a>
				9. Step motor	<a href="#">TM-284</a>
				10. Control valve	<a href="#">TM-322</a>
				OFF vehicle	11. Oil pump assembly
29		Engine does not start in "N" or "P" position.	ON vehicle	1. Ignition switch and starter	<a href="#">PG-41, STR-35</a>
				2. CVT position	<a href="#">TM-226</a>
				3. Transmission range switch	<a href="#">TM-233</a>
30	Other	Engine starts in positions other than "N" or "P".	ON vehicle	1. Ignition switch and starter	<a href="#">PG-41, STR-35</a>
				2. CVT position	<a href="#">TM-226</a>
				3. Transmission range switch	<a href="#">TM-233</a>
31		When brake pedal is depressed with ignition switch ON, selector lever cannot be shifted from "P" position to other position.	ON vehicle	1. Stop lamp switch	<a href="#">TM-290</a>
				2. Shift lock solenoid	
				3. CVT shift selector	
32		When brake pedal is not depressed with ignition switch ON, selector lever can be shifted from "P" position to other position.	ON vehicle	1. Stop lamp switch	<a href="#">TM-290</a>
				2. Shift lock solenoid	
				3. CVT shift selector	
33		Cannot be changed to manual mode.	ON vehicle	1. Manual mode switch	<a href="#">TM-259</a>
				2. CAN communication line	<a href="#">TM-228</a>
				3. Combination meters	<a href="#">MWI-50</a>
34		CVT indicator lamp does not come on.	ON vehicle	1. CAN communication line	<a href="#">TM-228</a>
				2. Combination meters	<a href="#">MWI-50</a>
				3. TCM power supply and ground	<a href="#">TM-272</a>



## PERIODIC MAINTENANCE

### CVT FLUID

#### Inspection

INFOID:000000009752651

#### CHECKING CVT FLUID

The fluid level should be checked with the fluid warmed up to 50 to 80°C (122 to 176°F). The fluid level check procedure is as follows:

1. Check for fluid leakage.
2. With the engine warmed up, drive the vehicle in an urban area. When ambient temperature is 20°C (68°F), it takes about 10 minutes for the CVT fluid to warm up to 50 to 80°C (122 to 176°F).
3. Park the vehicle on a level surface.
4. Apply parking brake firmly.
5. With engine at idle, while depressing brake pedal, move shift selector throughout the entire shift range.

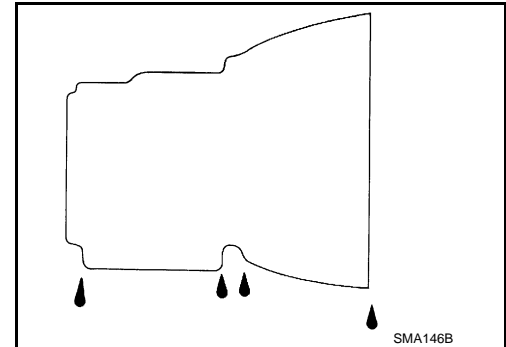

6. Pull out the CVT fluid level gauge from the CVT fluid charging pipe after pressing the tab on the CVT fluid level gauge to release the lock.

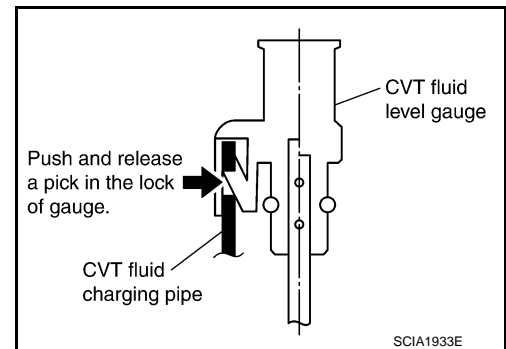

7. Wipe fluid off the CVT fluid level gauge. Insert the CVT fluid level gauge rotating 180° from the originally installed position, then securely push the CVT fluid level gauge until it meets the top end of the CVT fluid charging pipe.

**CAUTION:**

**When wiping away the CVT fluid level gauge, always use lint-free paper, not a cloth rag.**

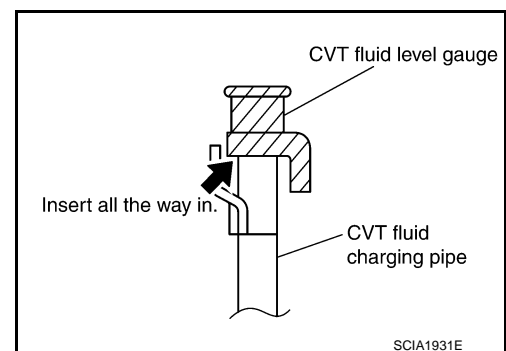

8. Place the selector lever in "P" or "N" and check that the fluid level is within the specified range.

**CAUTION:**

**When reinstalling CVT fluid level gauge, insert it into the CVT fluid charging pipe and rotate it to the original installation position until securely locked.**

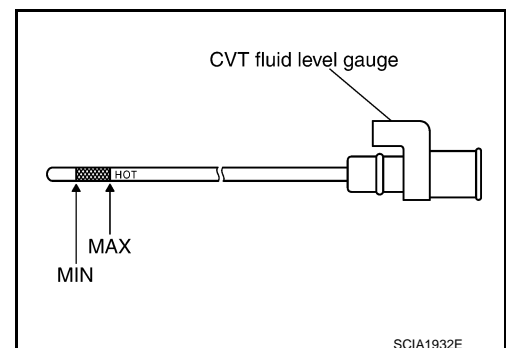

#### CVT FLUID CONDITION

# CVT FLUID

< PERIODIC MAINTENANCE >

[CVT: RE0F10B]

Check CVT fluid condition.

- If CVT fluid is very dark or smells burned, check operation of CVT. Flush cooling system after repair of CVT.
- If CVT fluid contains frictional material (clutches, brakes, etc.), replace radiator and flush cooler line using cleaning solvent and compressed air after repair of CVT. Refer to [TM-216, "Cleaning"](#).

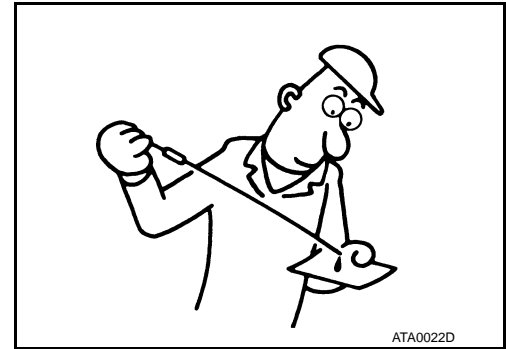

Fluid status	Conceivable cause	Required operation
Varnished (viscous varnish state)	CVT fluid become degraded due to high temperatures.	Replace the CVT fluid and check the CVT main unit and the vehicle for malfunctions (wire harnesses, cooler pipes, etc.)
Milky white or cloudy	Water in the fluid	Replace the CVT fluid and check for places where water is getting in.
Large amount of metal powder mixed in	Unusual wear of sliding parts within CVT	Replace the CVT fluid and check for improper operation of the CVT.

## Changing

INFOID:000000009752652

### CAUTION:

**Replace drain plug gasket with new ones at the final stage of the operation when installing.**

1. Remove drain plug from oil pan.
2. Remove drain plug gasket from drain plug.
3. Install drain plug gasket to drain plug.

### CAUTION:

**Never reuse drain plug gasket.**

4. Install drain plug to oil pan.

**Drain plug – tightening torque** : Refer to [TM-322, "Exploded View"](#).

5. Fill CVT fluid from CVT fluid charging pipe to the specified level.

**Recommended fluid and fluid capacity** : Refer to [MA-10, "Fluids and Lubricants"](#).

### CAUTION:

- Use only recommended CVT fluid. Never mix with other fluid.
- Using CVT fluid other than recommended CVT fluid will deteriorate in driveability and CVT durability, and may damage the CVT, which is not covered by the warranty.
- When filling CVT fluid, take care not to scatter heat generating parts such as exhaust.
- Sufficiently shake the container of CVT fluid before using.
- Delete CVT fluid deterioration date with CONSULT after changing CVT fluid.

6. With the engine warmed up, drive the vehicle in an urban area.

### NOTE:

When ambient temperature is 20°C (68°F), it takes about 10 minutes for the CVT fluid to warm up to 50 to 80°C (122 to 176°F).

7. Check CVT fluid level and condition.
8. Repeat steps 1 to 5 if CVT fluid has been contaminated.
9. Select "Data Monitor" in "TRANSMISSION" using CONSULT.
10. Select "CONFORM CVTF DETERIORTN".
11. Select "Erase".

# CVT SHIFT SELECTOR

< REMOVAL AND INSTALLATION >

[CVT: RE0F10B]

## REMOVAL AND INSTALLATION

### CVT SHIFT SELECTOR

Exploded View

INFOID:000000009752653

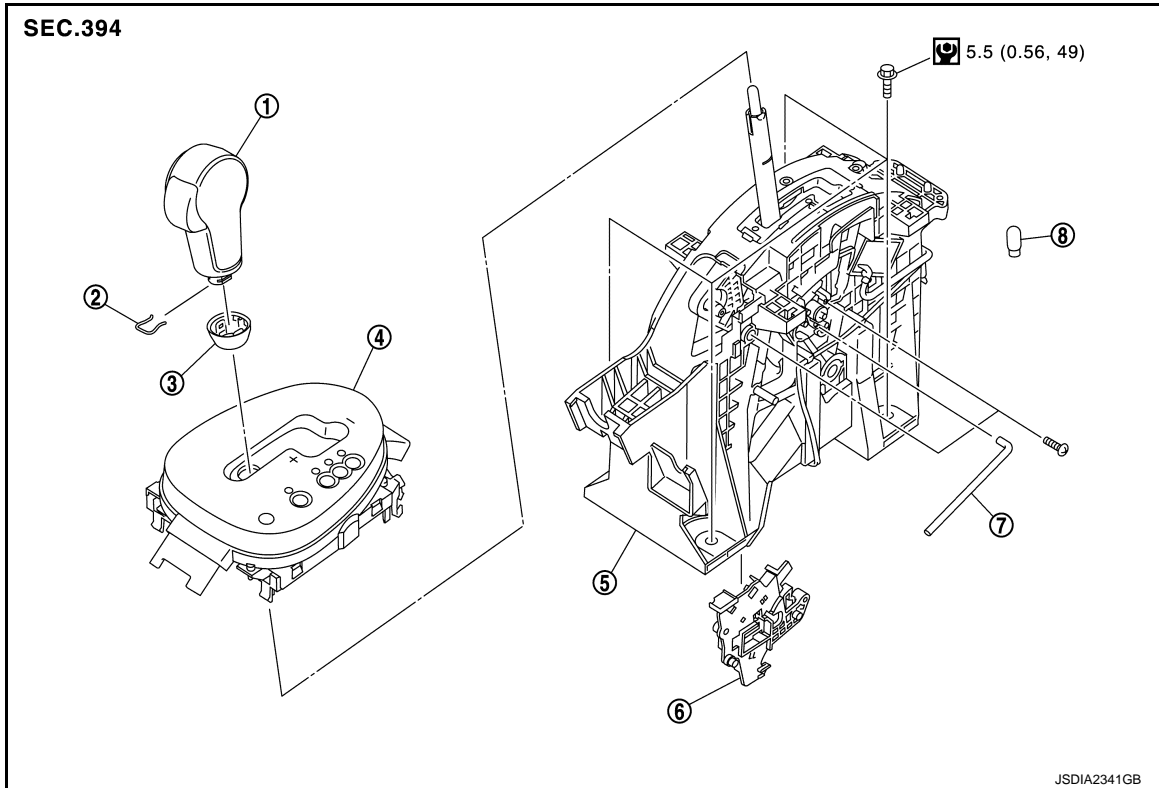

- |                              |                                |                    |
|------------------------------|--------------------------------|--------------------|
| 1. Selector lever knob       | 2. Lock pin                    | 3. Knob cover      |
| 4. Position indication panel | 5. CVT shift selector assembly | 6. Shift lock unit |
| 7. Key interlock rod*        | 8. Position indicator bulb     |                    |

 :N·m (kg-m, in-lb)

\*: Without push engine starter

## Removal and Installation

INFOID:000000009752654

### REMOVAL

#### CAUTION:

**Always apply the parking brake before performing removal and installation.**

1. Disconnect battery cable from negative terminal. Refer to [PG-99, "Removal and Installation"](#).
2. Shift the selector lever to "N" position.
3. Remove the center console. Refer to [IP-24, "Removal and Installation"](#).
4. Disconnect the CVT shift selector connector.
5. Shift the selector lever to "P" position.
6. Remove the key interlock cable from the CVT shift selector assembly. Refer to [TM-316, "Removal and Installation"](#) (Without push starter system).
7. Remove the control cable from the CVT shift selector assembly. Refer to [TM-311, "Removal and Installation"](#).
8. Remove the CVT shift selector assembly.

### INSTALLATION

Note the following, and install in the reverse order of removal.

# CVT SHIFT SELECTOR

## < REMOVAL AND INSTALLATION >

[CVT: RE0F10B]

- When connecting the control cable (1) to the CVT shift selector assembly (2), face the grooved surface of the rib (A) up and insert the control cable until it stops.

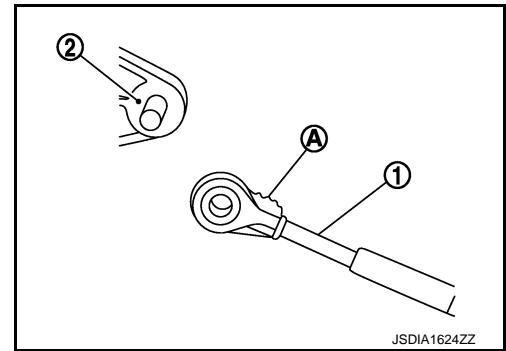

## Disassembly and Assembly

INFOID:000000009752655

### DISASSEMBLY

1. Slide the selector lever knob cover (1) down.  
**CAUTION:**  
**Never damage the knob cover.**
2. Pull out the lock pin (2).
3. Pull the selector lever knob (3) and knob cover upwards to remove them.
4. Remove the position lamp.

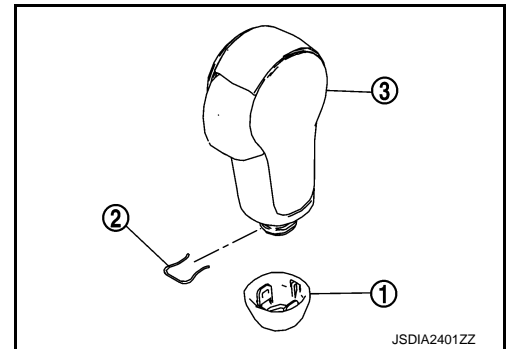

5. Disengage the hooks (A) (4 locations), and lift up the position indication panel (1) to separate it from the CVT shift selector assembly (2).  
**CAUTION:**  
**Never damage the CVT shift selector assembly.**
6. Remove the shift lock unit from the CVT shift selector assembly.
7. Disconnect the park position switch connector, detent switch connector, and shift lock solenoid connector from the shift lock unit.

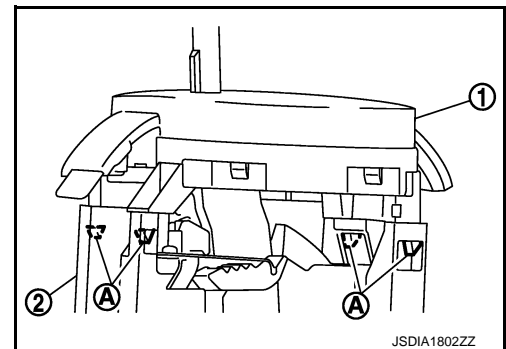

### ASSEMBLY

Note the following, and assemble in the reverse order of disassembly.

- Follow the procedure below and place the selector knob onto the CVT shift selector.

1. Install the lock pin (2) onto the selector lever knob (3).
2. Install the knob cover (1) onto the selector lever knob.
3. Press the selector lever knob onto the selector lever until it clicks.

#### **CAUTION:**

- **When pressing the selector lever knob onto the selector lever, never press the selector lever knob button.**
- **Never strike the selector lever knob to press it into place.**

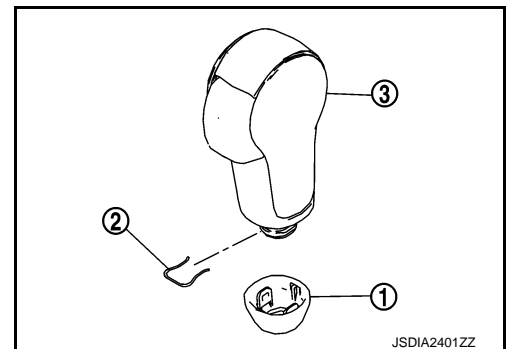

## Inspection

INFOID:000000009752656

### INSPECTION AFTER INSTALLATION

- Check the CVT position. If a malfunction is found, adjust the CVT position. Refer to [TM-226, "Inspection and Adjustment"](#).

# CVT SHIFT SELECTOR

< REMOVAL AND INSTALLATION >

[CVT: RE0F10B]

- The key can be removed only when the selector lever is in the “P” position. (With key interlock)
- It must not be possible to turn the ignition switch to LOCK when the selector lever is not in the “P” position. (With key interlock)

A  
B  
C  
TM  
E  
F  
G  
H  
I  
J  
K  
L  
M  
N  
O  
P

# CONTROL CABLE

< REMOVAL AND INSTALLATION >

[CVT: RE0F10B]

## CONTROL CABLE

Exploded View

INFOID:00000009752657

2WD MODELS

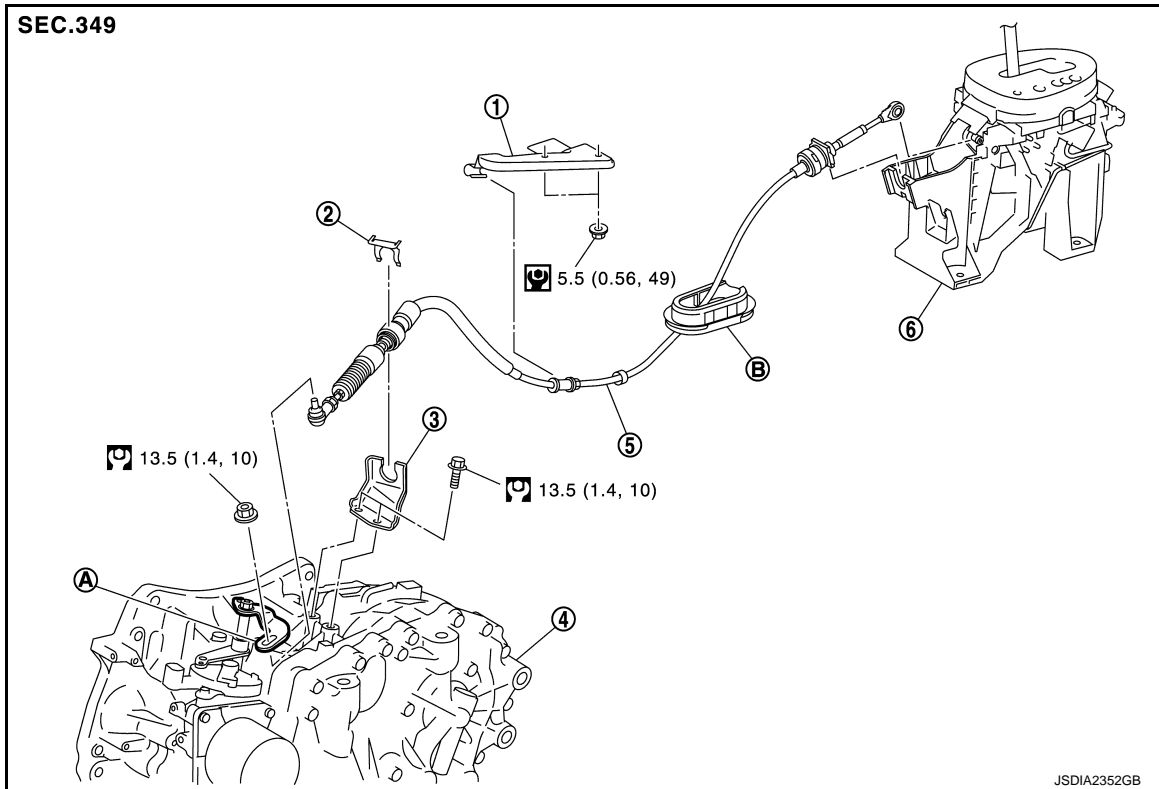

AWD MODELS

# CONTROL CABLE

< REMOVAL AND INSTALLATION >

[CVT: RE0F10B]

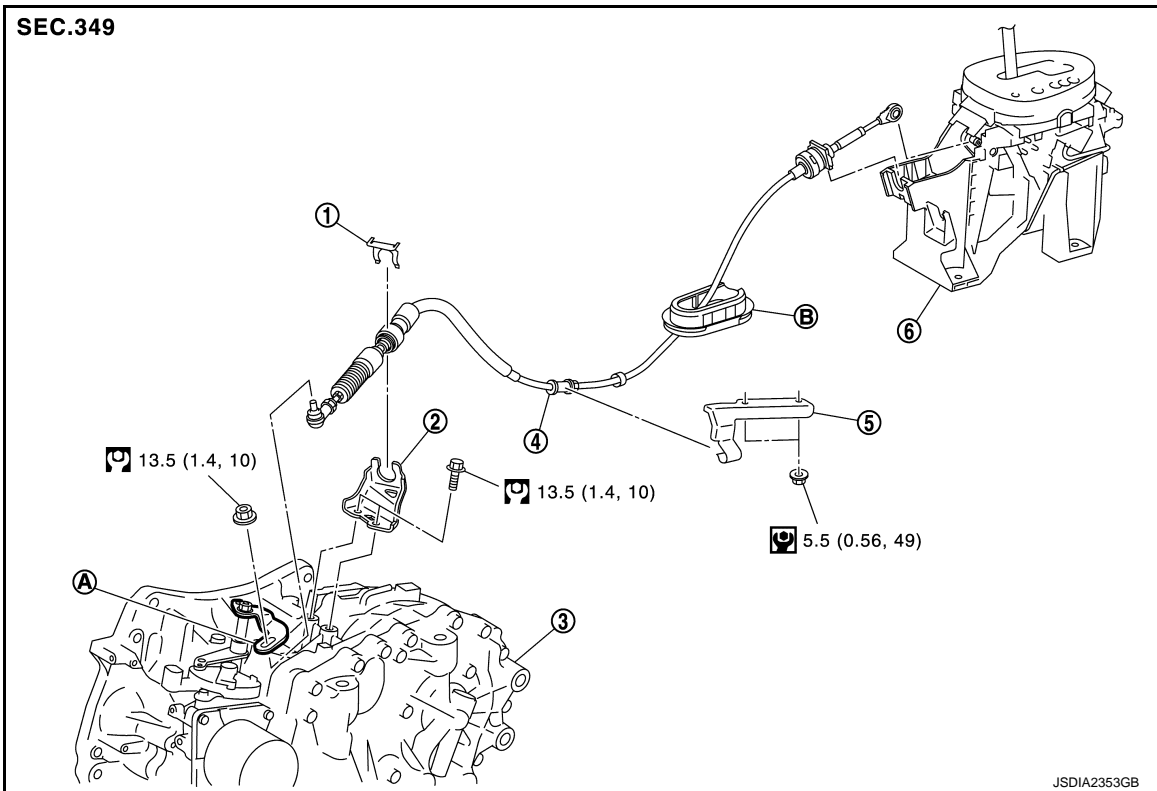

- 1. Lock plate
  - 2. Bracket A
  - 3. Transaxle assembly
  - 4. Control cable
  - 5. Bracket B
  - 6. CVT shift selector assembly
- A: Manual lever  
B: Grommet

: N·m (kg-m, ft-lb)

: N·m (kg-m, in-lb)

## Removal and Installation

INFOID:000000009752658

### REMOVAL

#### CAUTION:

Always apply the parking brake before performing removal and installation.

1. Remove the battery. Refer to [PG-99. "Removal and Installation"](#).
2. Remove the control cable from the CVT shift selector assembly. Refer to [TM-307. "Removal and Installation"](#).
3. Disengage the pawls (B) of the grommet (A), and pull downwards to remove.
4. Remove the control cable installation nut from the manual lever.

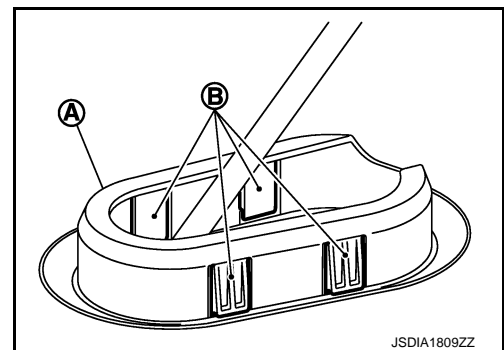

# CONTROL CABLE

[CVT: RE0F10B]

## < REMOVAL AND INSTALLATION >

5. Remove the lock plate (1).
6. Remove center muffler from the mounting rubber and lower the center muffler downward. Refer to [EX-8. "Removal and Installation"](#).
7. Lift up the heat plate.

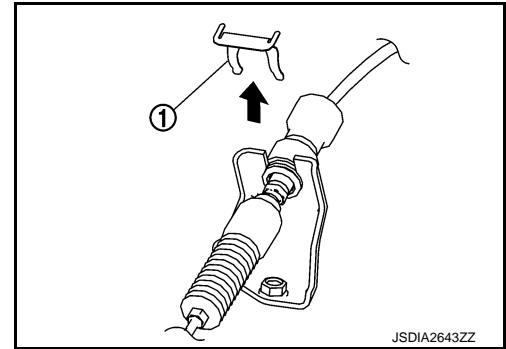

8. Remove the control cable (1) from the bracket (2).

← :Vehicle front

9. Remove the control cable from the vehicle.
10. Remove bracket.

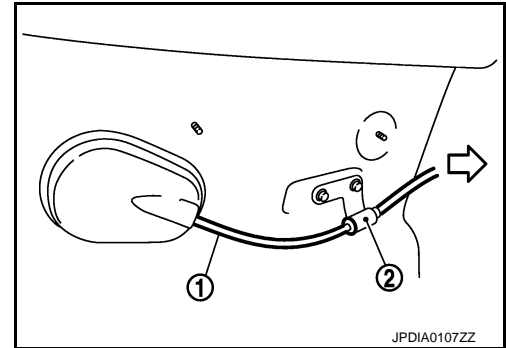

## INSTALLATION

Note the following, and install in the reverse order of removal.

- From below the vehicle, press the grommet (A) into place until the pawls (B) make a click sound.

### CAUTION:

- Place the grommet on the floor, then fasten it in place from below the vehicle.
- Check that pulling down on the grommet does not disconnect it.

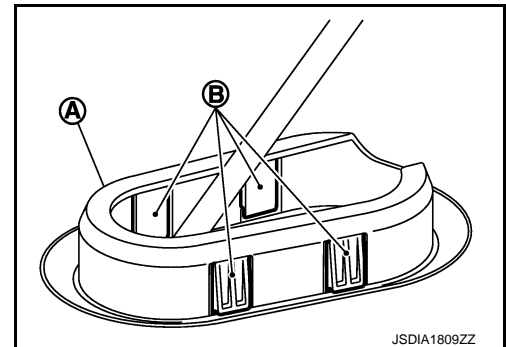

- Pay attention to the following when connecting the control cable to the CVT shift selector.

1. When connecting the control cable (1) to the CVT shift selector assembly (2), face the grooved surface of the rib (A) up and insert the control cable until it stops.

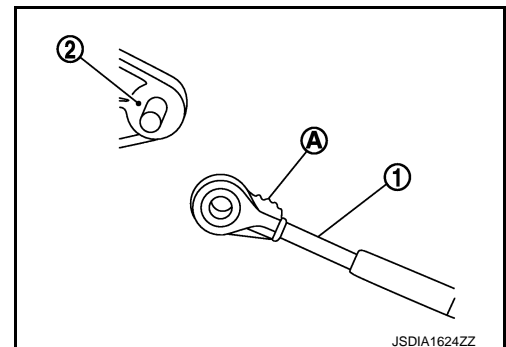



# CONTROL CABLE

## < REMOVAL AND INSTALLATION >

[CVT: RE0F10B]

2. Install the socket (A) onto the CVT shift selector.

**CAUTION:**

- Place the socket onto the CVT shift lever, then fasten it in place from above.
- Check that the pulling on the socket does not disconnect it.

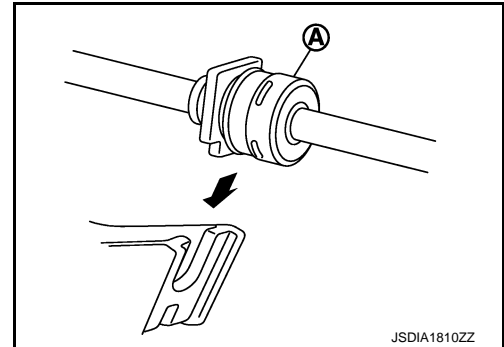

## Inspection

INFOID:000000009752659

### INSPECTION AFTER INSTALLATION

Check the CVT position. If a malfunction is found, adjust the CVT position. Refer to [TM-226. "Inspection and Adjustment"](#).

A  
B  
C  
TM  
E  
F  
G  
H  
I  
J  
K  
L  
M  
N  
O  
P

# PADDLE SHIFTER

< REMOVAL AND INSTALLATION >

[CVT: RE0F10B]

## PADDLE SHIFTER

Exploded View

INFOID:000000010198376

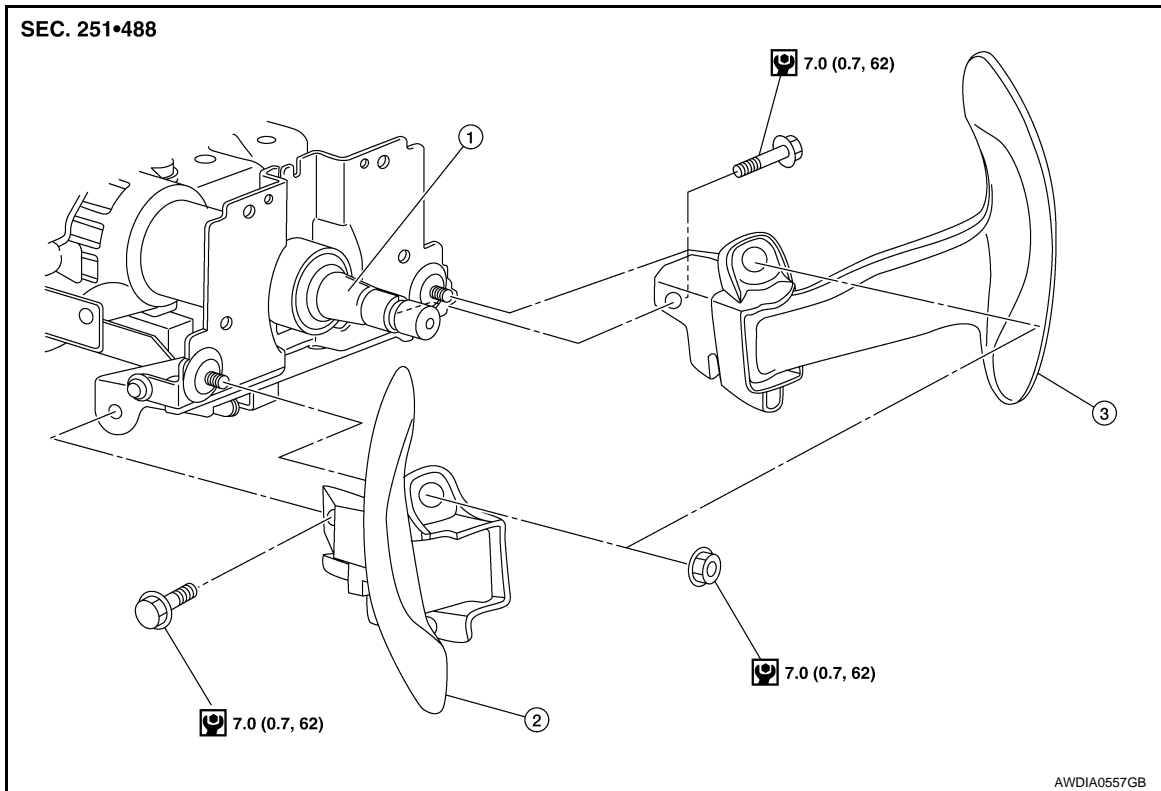

1. Steering column assembly      2. Paddle shifter (shift-down switch)      3. Paddle shifter (shift-up switch)

 : N·m (kg-m, in-lb)

## Removal and Installation

INFOID:000000010198377

### REMOVAL

1. Park the vehicle on a level surface.
2. Remove the driver air bag module. Refer to [SR-11, "Removal and Installation"](#).
3. Remove the steering wheel. Refer to [ST-9, "Removal and Installation"](#).
4. Remove the column cover. Refer to [IP-13, "Removal and Installation"](#).

# PADDLE SHIFTER

## < REMOVAL AND INSTALLATION >

[CVT: RE0F10B]

- Remove the paddle shifter connector (C) and (D) from paddle shifter.
  - Side of paddle shifter (shift-down switch)
  - Side of paddle shifter (shift-up switch)
- Remove the paddle shifter mounting bolts (E) and nuts (F).
- Remove the paddle shifter from the steering column assembly.

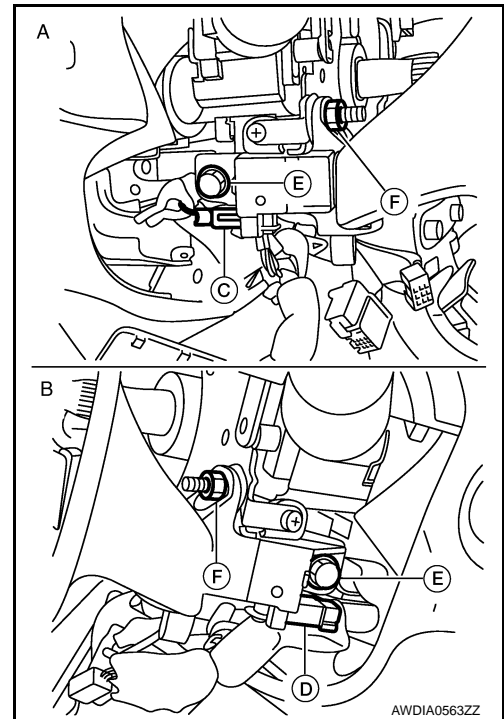

## INSTALLATION

Installation is in the reverse order of removal.

# KEY INTERLOCK CABLE

< REMOVAL AND INSTALLATION >

[CVT: RE0F10B]

## KEY INTERLOCK CABLE

Exploded View

INFOID:000000009752660

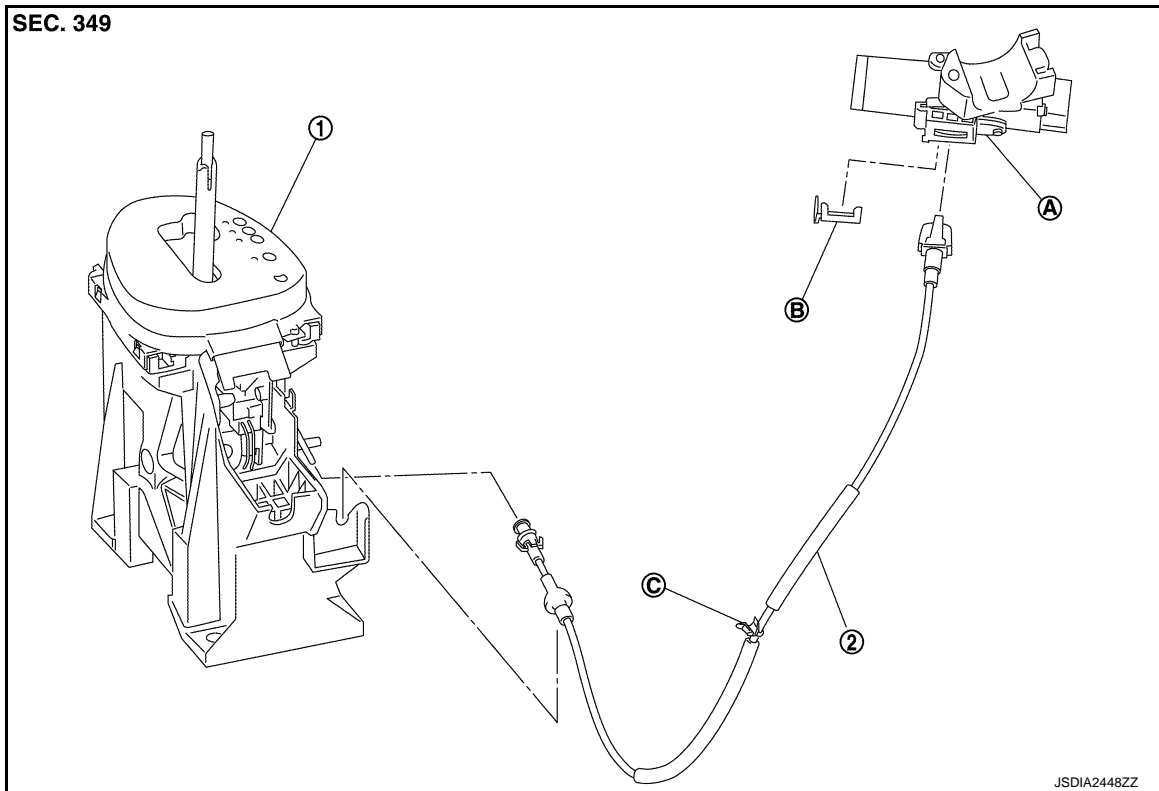

- |                                |                        |         |
|--------------------------------|------------------------|---------|
| 1. CVT shift selector assembly | 2. Key interlock cable |         |
| A: Key cylinder                | B: Clip                | C: Clip |

## Removal and Installation

INFOID:000000009752661

### REMOVAL

#### CAUTION:

Always apply the parking brake before performing removal and installation.

1. Shift the selector lever to the "N" position.
2. Remove the selector lever knob. Refer to [TM-308, "Disassembly and Assembly"](#).
3. Shift the selector lever to the "P" position.
4. Remove the center console. Refer to [IP-24, "Removal and Installation"](#).
5. Press the pawls (B) of the key interlock cable slider (A) while sliding it in the direction of the casing cap (C), and separate the adjusting holder (D) and slider.

E :Key interlock rod

6. Remove the key interlock cable from the CVT shift selector.
7. Remove the steering column lower cover and driver instrument lower panel. Refer to [IP-13, "Removal and Installation"](#).

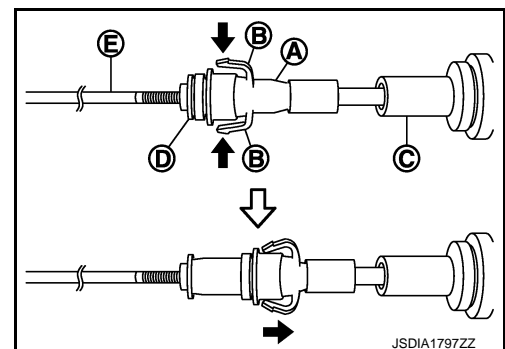

# KEY INTERLOCK CABLE

## < REMOVAL AND INSTALLATION >

[CVT: RE0F10B]

8. Lift clip (A) in the direction of the arrow (←C) and remove in the direction of the arrow (←D).

1 :Key interlock cable  
B :Key cylinder

9. Disconnect the key interlock cable from the key cylinder.  
10. Disengage the clip and disconnect the key interlock cable from the vehicle.

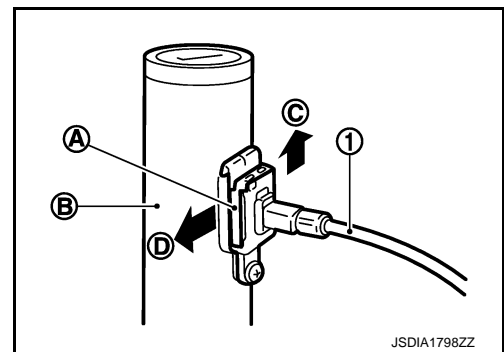

## INSTALLATION

Note the following, and install in the reverse order of removal.

- Install the adjusting holder (A) onto the key interlock rod (B), then install the casing cap (C) onto the CVT shift selector cable bracket (D).

### CAUTION:

- When installing the key interlock cable, never bend or twist the cable forcefully.
- After connecting the key interlock cable to the CVT shift selector cable bracket, be sure to check that the casing cap is completely fastened to the cable bracket. If the casing cap is easily displaced, replace the key interlock cable.

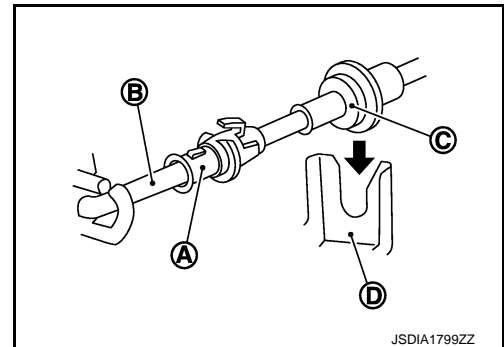

- While pressing the detent rod (B) down, slide the key interlock cable slider (A) toward the key interlock rod (D) side, and install the adjusting holder (C) and key interlock rod.

### CAUTION:

- Never squeeze the pawls on the key interlock cable slider when holding the slider.
- Never apply force in a perpendicular direction to the key interlock rod when sliding the slider.

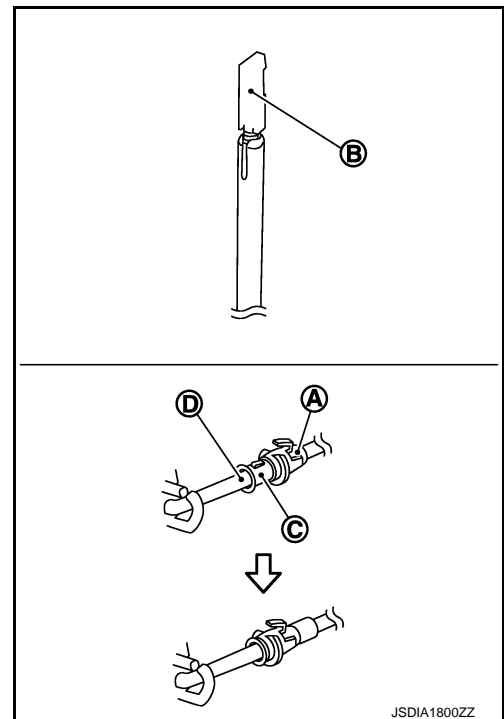

## Inspection

INFOID:000000009752662

## INSPECTION AFTER INSTALLATION

- Check the CVT position. If a malfunction is found, adjust the CVT position. Refer to [TM-226, "Inspection and Adjustment"](#).
- The key can be removed only when the selector lever is in the "P" position.
- It must not be possible to turn the ignition switch to LOCK when the selector lever is not in the "P" position.

# TRANSMISSION RANGE SWITCH

< REMOVAL AND INSTALLATION >

[CVT: RE0F10B]

## TRANSMISSION RANGE SWITCH

Exploded View

INFOID:000000009752663

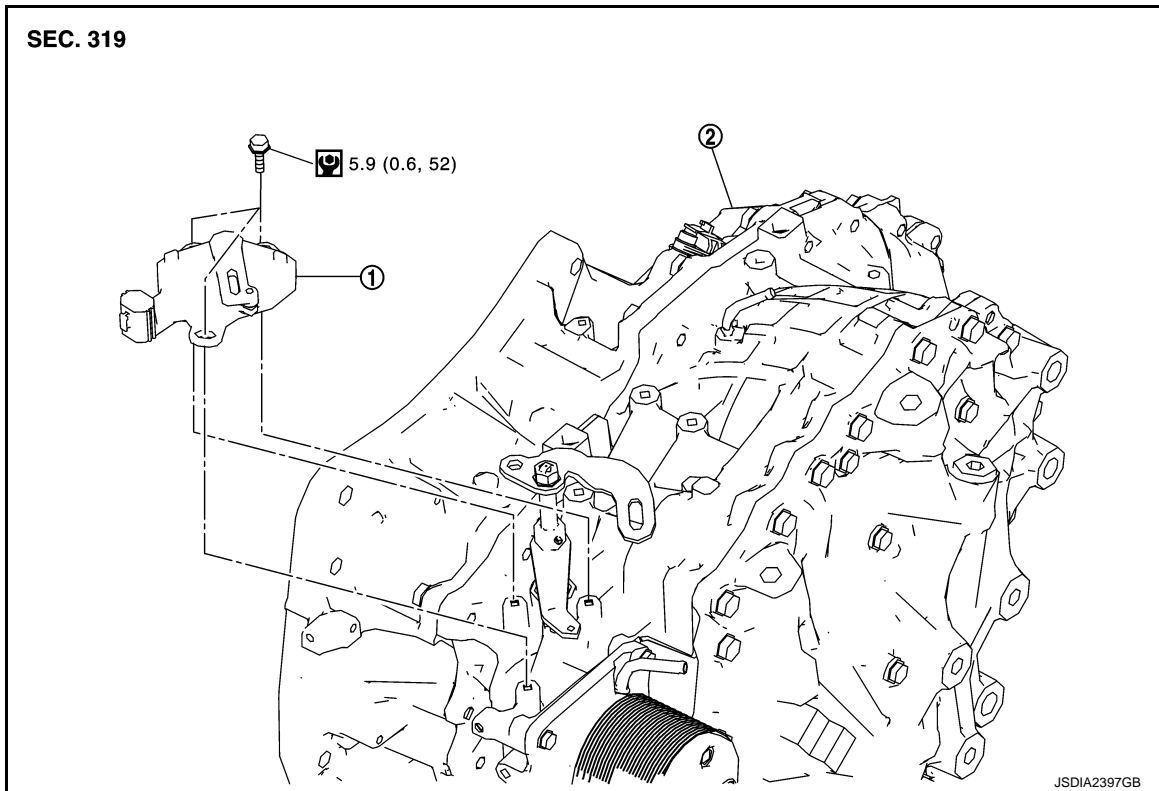

1. Transmission range switch      2. Transaxle assembly

 : N·m (kg·m, in·lb)

## Removal and Installation

INFOID:000000009752664

### REMOVAL

1. Remove battery. Refer to [PG-99, "Removal and Installation"](#).
2. Remove transmission range switch connector.
3. Remove control cable. Refer to [TM-311, "Removal and Installation"](#).
4. Remove transmission range switch from transaxle assembly.

### INSTALLATION

Install in the reverse order of removal.

## Inspection and Adjustment

INFOID:000000009752665

### ADJUSTMENT OF TRANSMISSION RANGE SWITCH

1. Move selector lever to "N" position.
2. Remove control cable from manual lever.

# TRANSMISSION RANGE SWITCH

< REMOVAL AND INSTALLATION >

[CVT: RE0F10B]

3. Loosen mounting bolts (←) of transmission range switch. Insert a pin ( $\phi 4$  mm) into the adjusting holes (A) on both transmission range switch and manual lever for adjusting the position.
4. Tighten mounting bolts of transmission range switch.
5. Connect control cable on manual lever. Refer to [TM-226. "Inspection and Adjustment"](#).

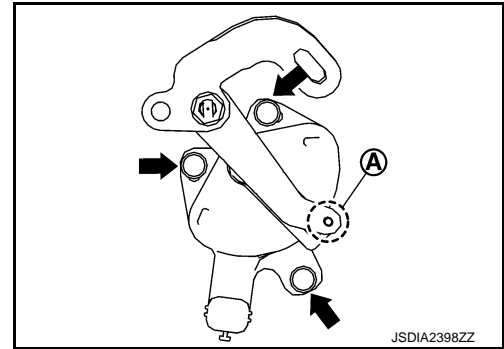

## ADJUSTMENT AFTER INSTALLATION

Adjust the CVT positions after installing the CVT shift selector. Refer to [TM-226. "Inspection and Adjustment"](#).

## INSPECTION AFTER INSTALLATION

Check the CVT positions after adjusting the CVT positions. Refer to [TM-226. "Inspection and Adjustment"](#).

A  
B  
C  
TM  
E  
F  
G  
H  
I  
J  
K  
L  
M  
N  
O  
P





# AIR BREATHER HOSE

< REMOVAL AND INSTALLATION >

[CVT: RE0F10B]

## AIR BREATHER HOSE

### Removal and Installation

INFOID:000000009752669

#### REMOVAL

1. Remove air cleaner case. Refer to [EM-25, "Removal and Installation"](#).
2. Remove clip (A) from bracket.
3. Remove air breather hose (1) from transaxle assembly.

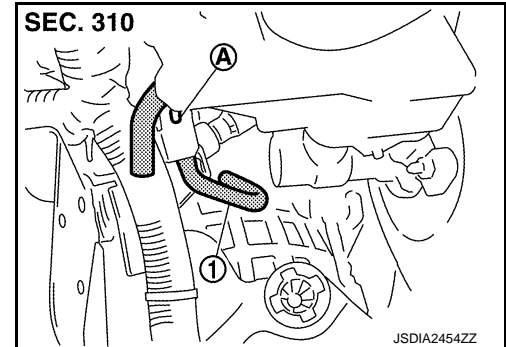

#### INSTALLATION

Note the following, and install in the reverse order of removal.

#### CAUTION:

- Never bend the air breather hose to prevent damage to the hose.
- Install air breather hose (1) to transaxle tube (A) all the way to the curve of the tube.
- Install air breather hose to transaxle tube so that the paint mark (B) is facing upward.

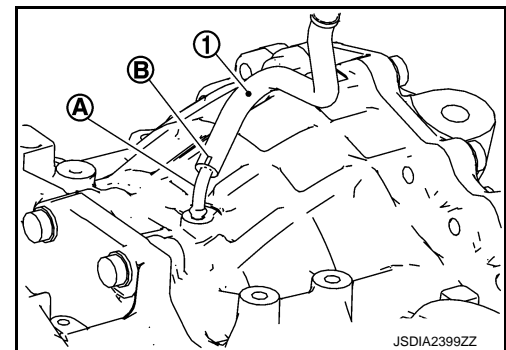

- Securely install the clip (A) to the bracket.

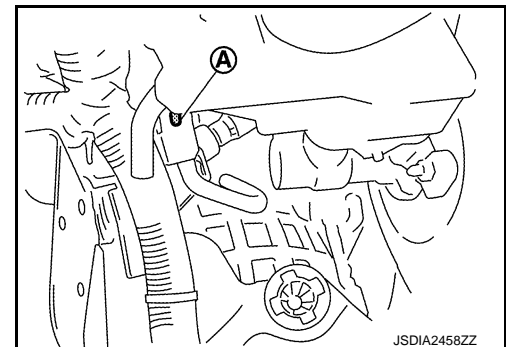

A  
B  
C  
TM  
E  
F  
G  
H  
I  
J  
K  
L  
M  
N  
O  
P

# CONTROL VALVE

< REMOVAL AND INSTALLATION >

[CVT: RE0F10B]

## CONTROL VALVE

Exploded View

INFOID:000000009752670

### COMPONENT PARTS LOCATION

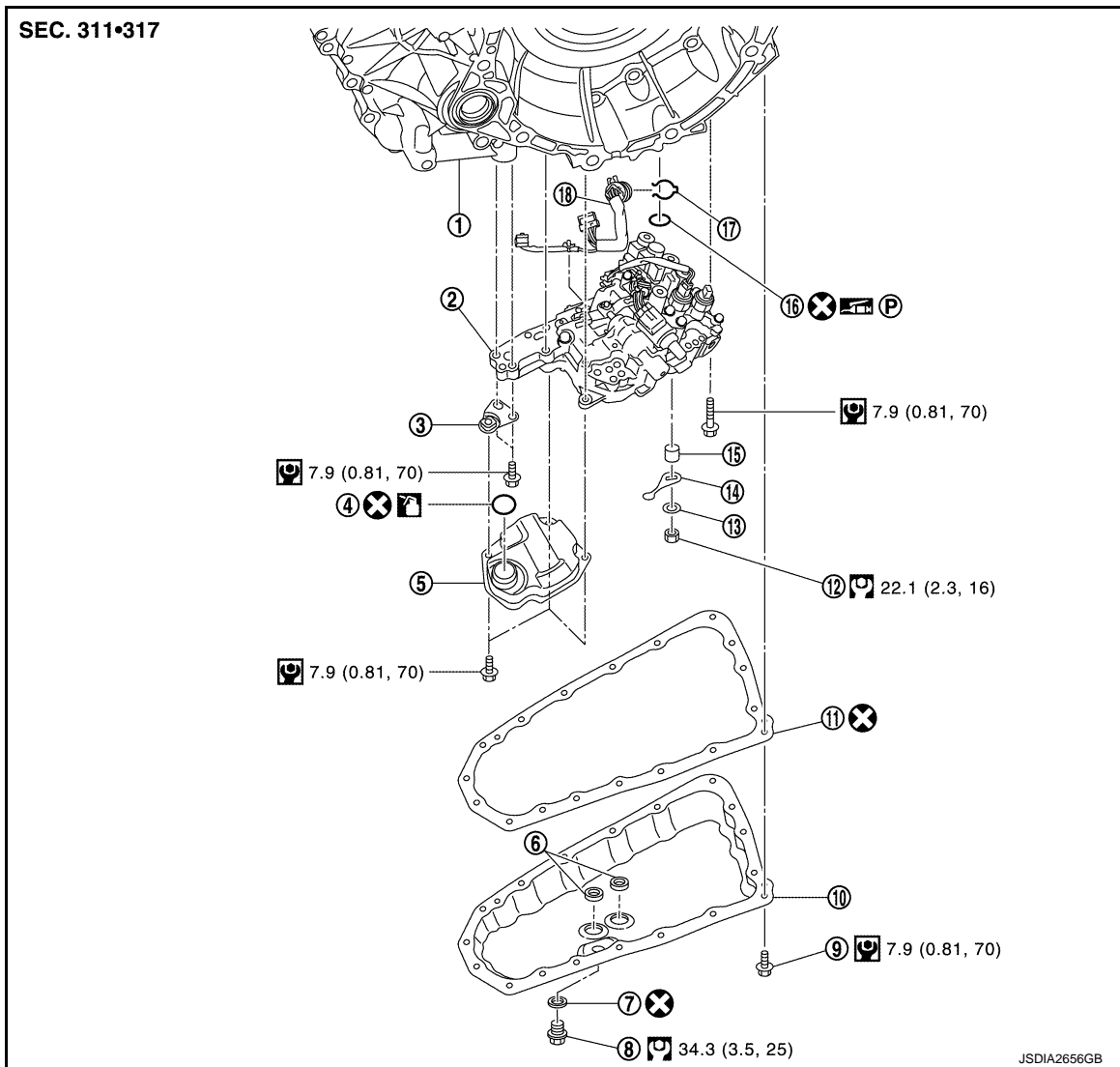

- |                       |                          |                            |
|-----------------------|--------------------------|----------------------------|
| 1. Transaxle assembly | 2. Control valve         | 3. Bracket                 |
| 4. O-ring             | 5. Oil strainer assembly | 6. Magnet                  |
| 7. Drain plug gasket  | 8. Drain plug            | 9. Oil pan mounting bolt   |
| 10. Oil pan           | 11. Oil pan gasket       | 12. Lock nut               |
| 13. Washer            | 14. Manual plate         | 15. Collar                 |
| 16. Lip seal          | 17. Snap ring            | 18. Terminal cord assembly |

⊗ : Always replace after every disassembly.

⊙ : N·m (kg-m, ft-lb)

⊙ : N·m (kg-m, in-lb)

⊙ : Apply CVT fluid

## Removal and Installation

INFOID:000000009752671

### REMOVAL

# CONTROL VALVE

## < REMOVAL AND INSTALLATION >

[CVT: RE0F10B]

1. Disconnect battery cable from negative terminal. Refer to [PG-99, "Exploded View"](#).
2. Remove drain plug from oil pan and then drain the CVT fluid.
3. Remove drain plug gasket.
4. Disconnect the CVT unit connector. Refer to [TM-145, "Removal and Installation Procedure for CVT Unit Connector"](#).
5. Remove the snap ring (1) from the CVT unit connector (A).

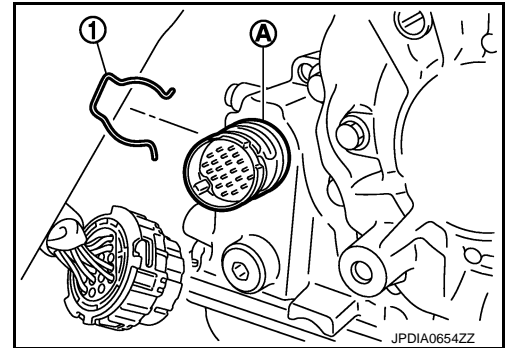

6. Press the CVT unit connector (A) into the transaxle case.

**CAUTION:**

**Never damage the CVT unit connector.**

**NOTE:**

Clean around the connector to prevent foreign materials from entering into the transaxle case.

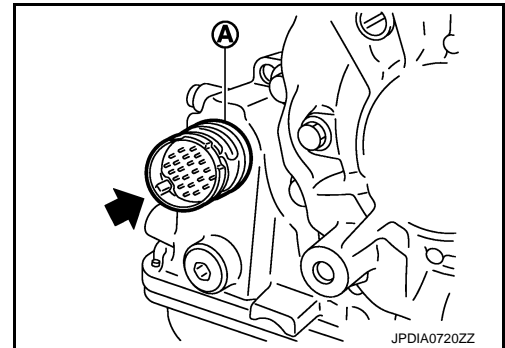

7. Remove the oil pan mounting bolts, and then remove the oil pan and oil pan gasket.
8. Remove the magnets from the oil pan.
9. Remove the lock nut (1) and washer (2), and then remove the manual plate (3).

← : Vehicle front

10. Remove the collar (4) from the manual shaft (A).

**CAUTION:**

**Never drop the collar.**

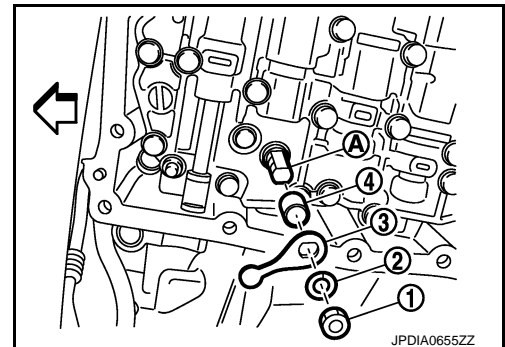

11. Disconnect the control valve connectors (A) and (B).

← : Clip

← : Vehicle front

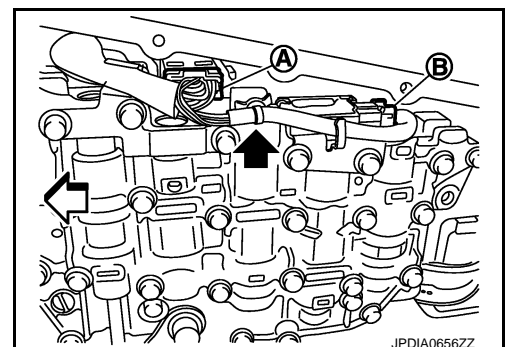

# CONTROL VALVE

## < REMOVAL AND INSTALLATION >

[CVT: RE0F10B]

12. Remove the oil strainer assembly mounting bolts (A) and (B), and then remove the oil strainer assembly (1).

⇐ : Vehicle front

13. Remove O-ring from oil strainer assembly.

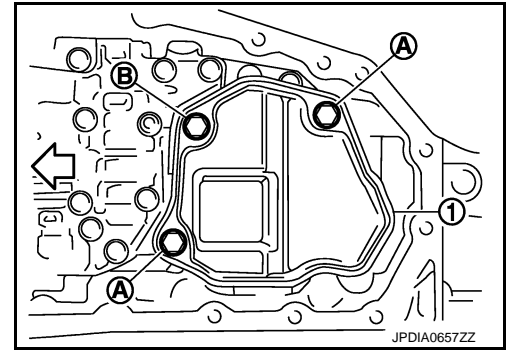

14. Remove the bracket (1).

← : Bolt

⇐ : Vehicle front

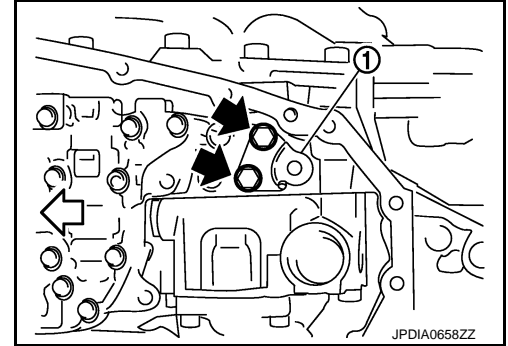

15. Remove the control valve mounting bolts (A) and (B), and then remove the control valve from the transaxle case.

⇐ : Vehicle front

**CAUTION:**

**Never drop the control valve, ratio control valve and manual shaft.**

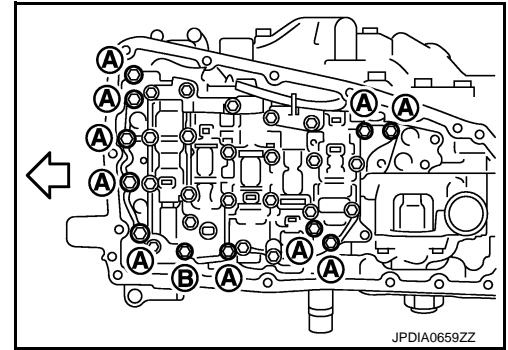

16. Remove terminal cord assembly (1) from the transaxle case inside.

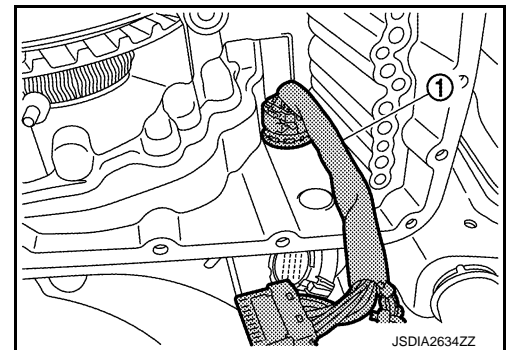

17. Remove the lip seal (1) from the transaxle case.

⇐ : Vehicle front

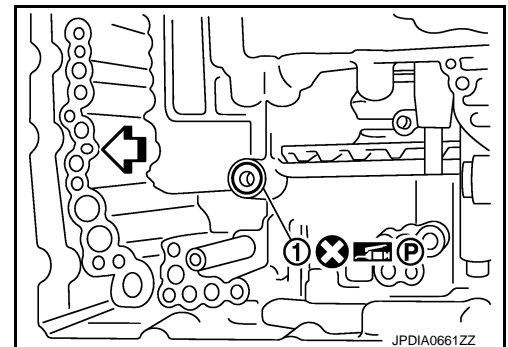

# CONTROL VALVE

< REMOVAL AND INSTALLATION >

[CVT: RE0F10B]

## INSTALLATION

1. Install the lip seal (1) to the transaxle case.

← : Vehicle front

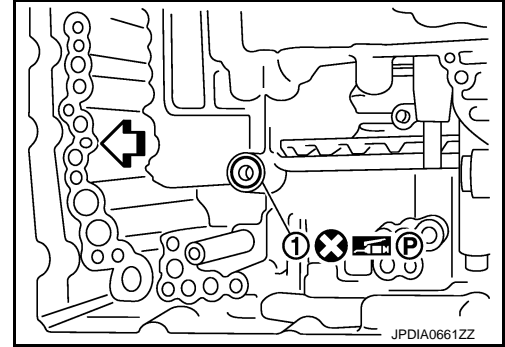

2. Install terminal cord assembly (1) to the transaxle case.

**CAUTION:**

Connect the CVT unit connector with the stopper facing up, and then press in until it clicks.

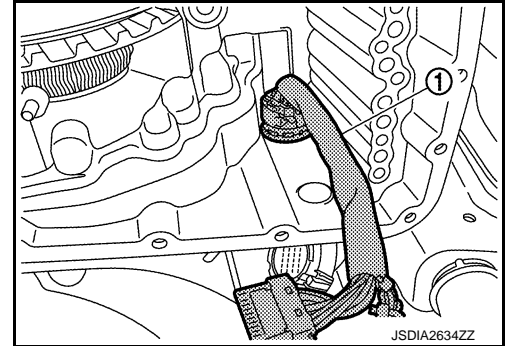

3. Press in the ratio control valve (B) in the (←) direction, and then fix the linkage in the position shown in the figure with the linkage fixing pin (A) from the back of control valve through the hole for fixing.

4. Check that one end of linkage engages with the step motor end (C) and that the linkage is in the direction shown in the figure.

5. Install the control valve to the transaxle case.

**CAUTION:**

- Never drop the linkage fixing pin. If it is dropped, repeat the installation procedure from step 3.
- Never pinch the harness into between the control valve and the transaxle case.
- Never drop the control valve, ratio control valve and manual shaft.

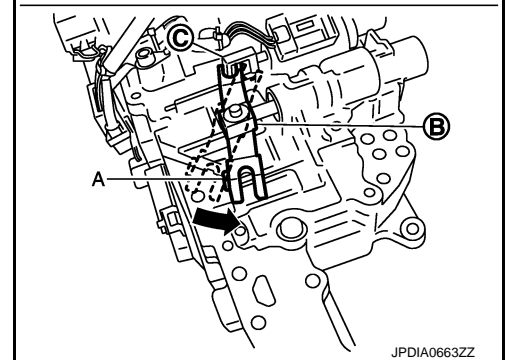
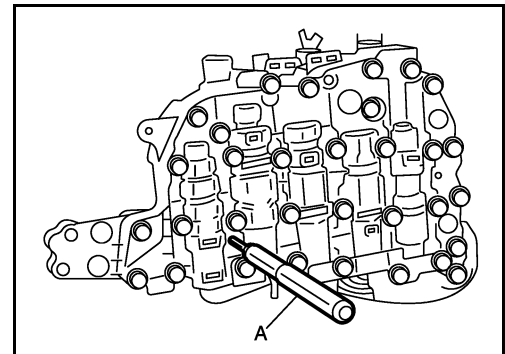

A  
B  
C  
TM  
E  
F  
G  
H  
I  
J  
K  
L  
M  
N  
O  
P

# CONTROL VALVE

[CVT: RE0F10B]

## < REMOVAL AND INSTALLATION >

6. Fix the control valve using the control valve mounting bolts (A) and (B).

↩ : Vehicle front

Bolt	Bolt length (mm)	Number of bolts
A	54	10
B	44	1

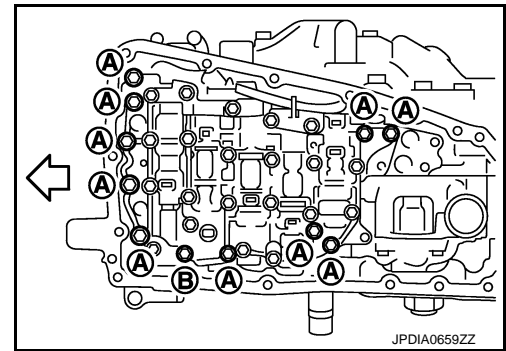

7. Pull the linkage fixing pin out.  
8. Connect the control valve connectors (A) and (B).

← : Clip

↩ : Vehicle front

**CAUTION:**

- Never pinch the harness into between the control valve and the transaxle case.
- Securely insert the connector until it clicks and locks.

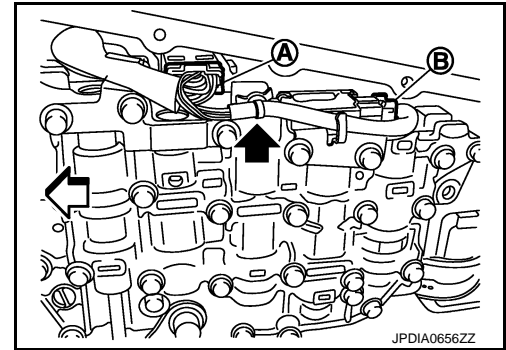

9. Install the bracket (1).

← : Bolt

↩ : Vehicle front

10. Install O-ring to oil strainer assembly.

**CAUTION:**

- Never reuse O-ring.
- Apply CVT fluid to O-ring.

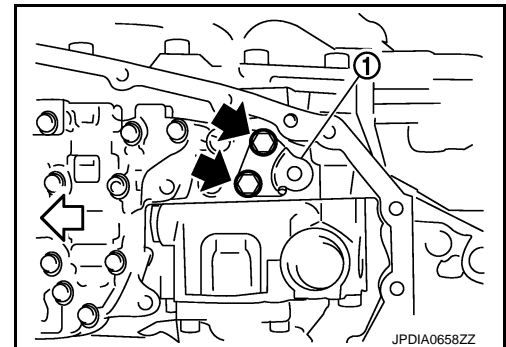

11. Install the oil strainer assembly (1) using the oil strainer assembly mounting bolts (A) and (B).

↩ : Vehicle front

Bolt	Bolt length (mm)	Number of bolts
A	12	2
B	44	1

**NOTE:**

Remove the bracket and adjust the position again if the bolt hole positions are not aligned.

12. Install the collar to the manual shaft.

**CAUTION:**

Never drop the collar.

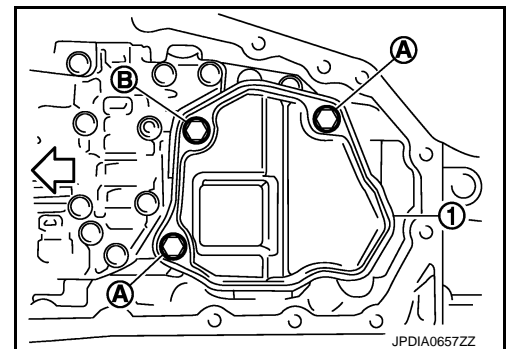

# CONTROL VALVE

## < REMOVAL AND INSTALLATION >

[CVT: RE0F10B]

13. Install the manual plate (1) while aligning with the groove (A) of the manual valve.

**CAUTION:**

Assemble the manual plate while aligning its end with the cutout (←) of the manual valve.

← : Vehicle front

14. Install the washer (2) and the lock-nut (3), and then tighten to the specified torque.

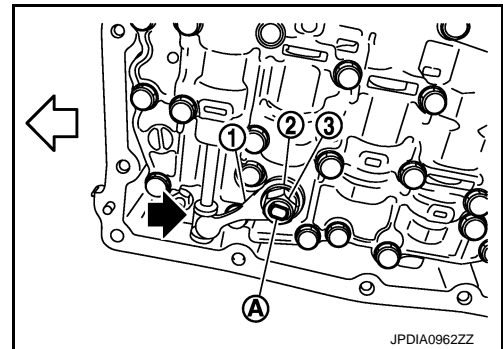

15. Install the snap ring (1) to the CVT unit connector (A).

16. Connect the CVT unit connector. Refer to [TM-145, "Removal and Installation Procedure for CVT Unit Connector"](#).

17. Install the magnet while aligning it with the convex side of oil pan.

**CAUTION:**

Completely eliminate the iron powder from the magnet mounting area of oil pan and the magnet.

18. Install the oil pan to the transaxle case with the following procedure.

1. Install the oil pan gasket to the oil pan.

**CAUTION:**

- Completely wipe out any moisture, oil, and old gasket from the oil pan gasket mounting surface and bolt mounting hole of oil pan and transaxle case.
- Never reuse oil pan gasket.

2. Install the oil pan assembly to the transaxle case, and then temporarily tighten the oil pan mounting bolt.

3. Tighten the oil pan mounting bolts in the order shown in the figure to the specified torque.

4. Tighten the oil pan mounting bolts again clockwise from (1) shown in the figure to the specified torque.

19. Install drain plug gasket to drain plug.

**CAUTION:**

Never reuse drain plug gasket.

20. Install drain plug to oil pan.

21. Fill CVT fluid from CVT fluid charging pipe to the specified level.

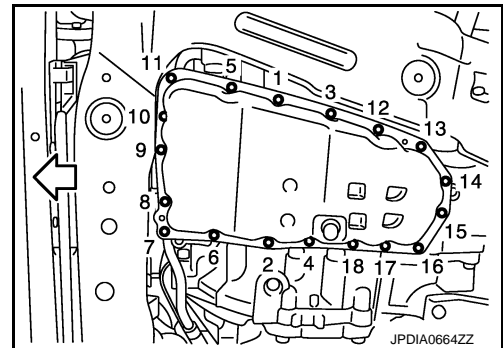
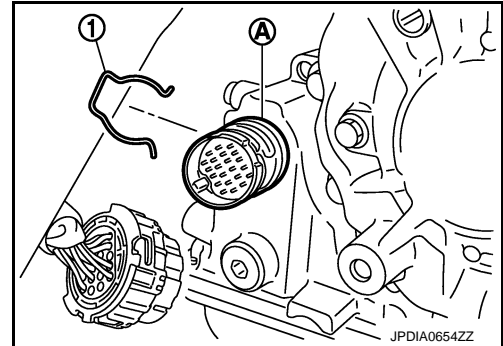

CVT fluid : Refer to [MA-10, "Fluids and Lubricants"](#).  
Fluid capacity

**CAUTION:**

- Use only Genuine CVT fluid. Never mix with other fluid.
- Using CVT fluid other than Genuine CVT fluid will deteriorate in driveability and CVT durability, and may damage the CVT, which is not covered by the warranty.
- When filling CVT fluid, take care not to scatter heat generating parts such as exhaust.
- Sufficiently shake the container of CVT fluid before using.
- Delete CVT fluid deterioration date with CONSULT after changing CVT fluid. Refer to [TM-185, "CONSULT Function"](#).

22. With the engine warmed up, drive the vehicle in an urban area.

**NOTE:**

When ambient temperature is 20°C (68°F), it takes about 10 minutes for the CVT fluid to warm up to 50 to 80°C (122 to 176°F).

23. Check CVT fluid level and condition. Refer to [TM-305, "Inspection"](#).

24. Connect battery cable to negative terminal. Refer to [PG-99, "Exploded View"](#).

# CONTROL VALVE

< REMOVAL AND INSTALLATION >

[CVT: RE0F10B]

## Inspection and Adjustment

INFOID:000000009752672

### INSPECTION AFTER REMOVAL

Check oil pan for foreign material.

- If a large amount of worn material is found, clutch plate may be worn.
  - If iron powder is found, bearings, gears, or clutch plates may be worn.
  - If aluminum powder is found, bushing may be worn, or chips or burrs of aluminum casting parts may enter.
- Check points where wear is found in all cases.

### INSPECTION AFTER INSTALLATION

Check the CVT fluid level and leakage. Refer to [TM-305, "Inspection"](#).

### ADJUSTMENT AFTER INSTALLATION

Perform "ADDITIONAL SERVICE WHEN REPLACING CONTROL VALVE OR TRANSAXLE ASSEMBLY".  
Refer to [TM-214, "Description"](#).



# PRIMARY SPEED SENSOR

< REMOVAL AND INSTALLATION >

[CVT: RE0F10B]

## PRIMARY SPEED SENSOR

Exploded View

INFOID:000000009752673

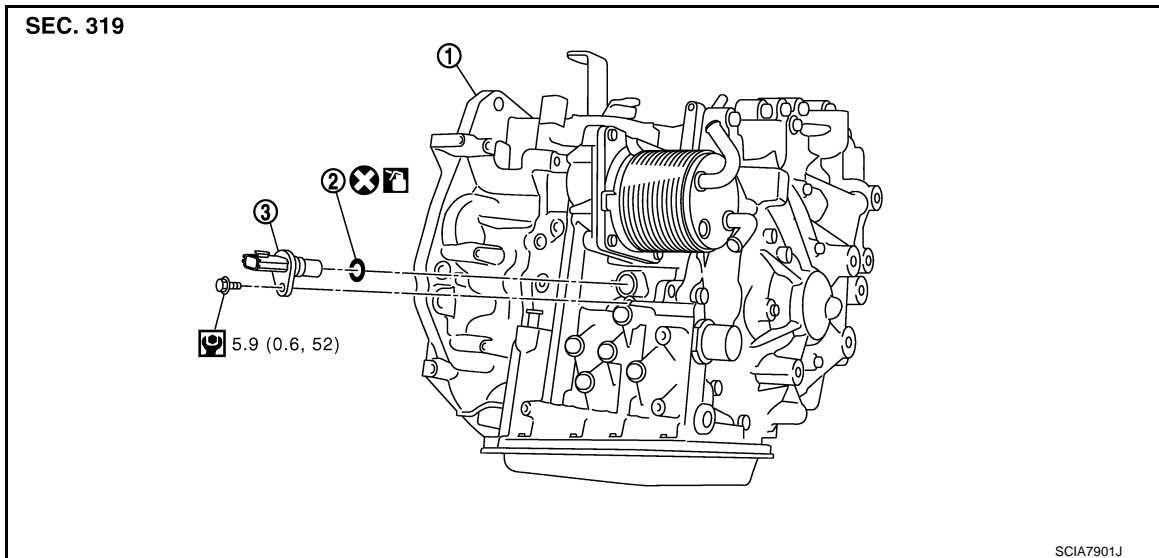

1. Transaxle assembly                      2. O-ring                                      3. Primary speed sensor

⊗ : Always replace after every disassembly.

Ⓜ : N·m (kg-m, in-lb)

🔧 : Apply CVT fluid

## Removal and Installation

INFOID:000000009752674

### REMOVAL

1. Remove the battery. Refer to [PG-99. "Removal and Installation"](#).
2. Remove ECM and bracket as a set.
3. Remove primary speed sensor connector.
4. Remove primary speed sensor.
5. Remove O-ring from primary speed sensor.

### INSTALLATION

Note the following, and install in the reverse order of removal.

#### CAUTION:

- Never reuse O-ring.
- Apply CVT fluid to O-ring.

### Inspection

INFOID:000000009752675

### INSPECTION AFTER INSTALLATION

Check for CVT fluid leakage and CVT fluid level. Refer to [TM-305. "Inspection"](#).

A  
B  
C  
TM  
E  
F  
G  
H  
I  
J  
K  
L  
M  
N  
O  
P

# SECONDARY SPEED SENSOR

< REMOVAL AND INSTALLATION >

[CVT: RE0F10B]

## SECONDARY SPEED SENSOR

Exploded View

INFOID:000000009752676

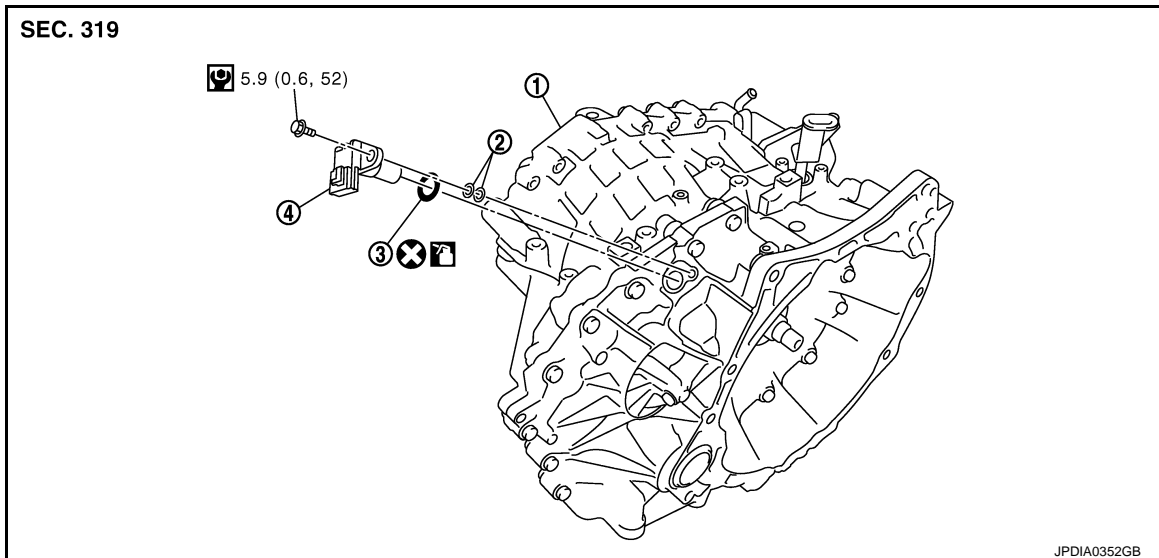

1. Transaxle assembly                      2. Shim                                      3. O-ring

4. Secondary speed sensor

⊗ : Always replace after every disassembly.

5.9 (0.6, 52) : N·m (kg-m, in-lb)

👉 : Apply CVT fluid

## Removal and Installation

INFOID:000000009752677

### REMOVAL

1. Remove air cleaner case. Refer to [EM-25. "Removal and Installation"](#).
2. Remove secondary speed sensor connector.
3. Remove secondary speed sensor (1) and shims (2).
4. Remove O-ring (3) from secondary speed sensor.

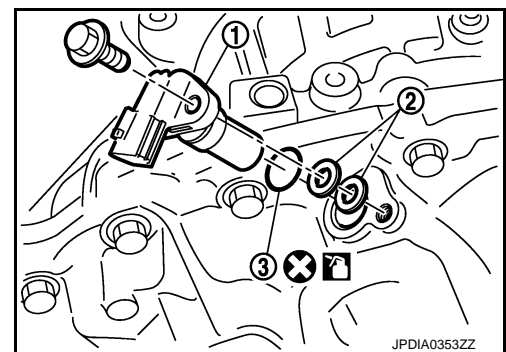

### INSTALLATION

Note the following, and install in the reverse order of removal.

#### CAUTION:

- Never reuse O-ring.
- Apply CVT fluid to O-ring.
- Install two pieces of shims.

### Inspection

INFOID:000000009752678

### INSPECTION AFTER INSTALLATION

# SECONDARY SPEED SENSOR

< REMOVAL AND INSTALLATION >

[CVT: RE0F10B]

Check for CVT fluid leakage and CVT fluid level. Refer to [TM-305. "Inspection"](#).

A

B

C

TM

E

F

G

H

I

J

K

L

M

N

O

P

# DIFFERENTIAL SIDE OIL SEAL

< REMOVAL AND INSTALLATION >

[CVT: RE0F10B]

## DIFFERENTIAL SIDE OIL SEAL

2WD

2WD : Exploded View

INFOID:000000009752679

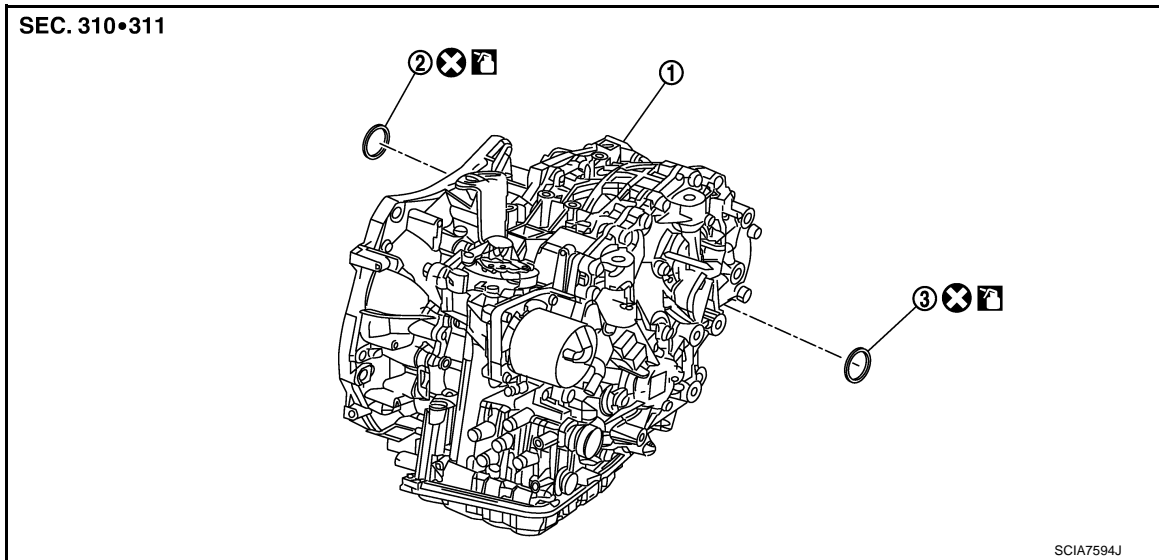

1. Transaxle assembly

2. Differential side oil seal (Converter housing side)

3. Differential side oil seal (Transaxle case side)

⊗ : Always replace after every disassembly.

☰ : Apply CVT fluid

## 2WD : Removal and Installation

INFOID:000000009752680

### REMOVAL

#### NOTE:

Cap or plug openings to prevent fluid from spilling.

1. Remove the left/right front drive shaft. Refer to [FAX-20. "LEFT SIDE : Removal and Installation"](#) (left side), [FAX-22. "RIGHT SIDE : Removal and Installation"](#) (right side).

2. Use oil seal remover or a similar means and remove the differential side oil seal.

#### CAUTION:

**When removing the differential side oil seal, be careful not to scratch the oil seal mounting surfaces of the transaxle case and converter housing.**

### INSTALLATION

Note the following, and install in the reverse order of removal.

#### CAUTION:

- Never reuse differential side oil seal.
- Apply Genuine CVT fluid to the differential side oil seal lip and around the oil seal.
- When inserting the drive shaft, be sure to use a protector (SST: KV38107900).

# DIFFERENTIAL SIDE OIL SEAL

## < REMOVAL AND INSTALLATION >

[CVT: RE0F10B]

Use a drift (commercial service tool) and drive the differential side oil seal in until the amount of oil seal projection from the case edge matches dimensions (C) and (D).

**CAUTION:**

**Be careful not to scratch the lip of the differential side oil seal when press-fitting it.**

- A : Transaxle case side
- B : Converter housing side

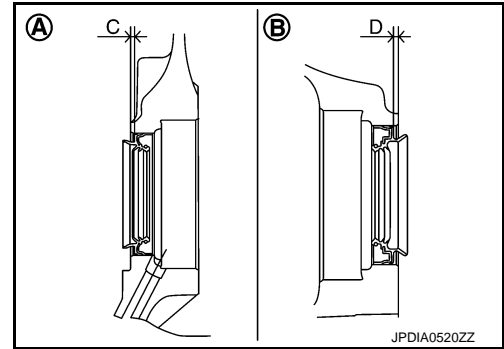

**Dimension "C"** :Height difference from case end surface is within  $1.8 \pm 0.5$  mm ( $0.071 \pm 0.020$  in).

**Dimension "D"** :Height difference from case end surface is within  $2.2 \pm 0.5$  mm ( $0.087 \pm 0.020$  in).

**NOTE:**

The reference is the pull-in direction of the differential side oil seal.

Drift to be used:

Location	Commercial Service Tools
Transaxle case side	Commercial service tool with outer dia. 54 mm (2.13 in) and inner dia. 50 mm (1.97 in)
Converter housing side	

## 2WD : Inspection

INFOID:000000009752681

## INSPECTION AFTER INSTALLATION

Check for CVT fluid leakage and CVT fluid level. Refer to [TM-305, "Inspection"](#).

## AWD

## AWD : Exploded View

INFOID:000000009752682

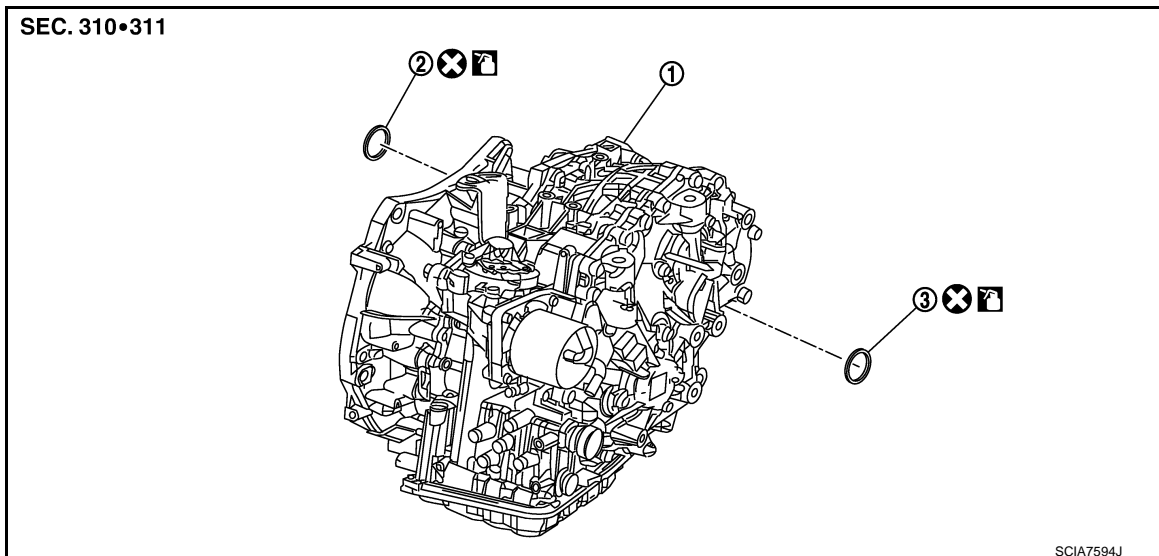

1. Transaxle assembly
2. Differential side oil seal (Converter housing side)
3. Differential side oil seal (Transaxle case side)

: Always replace after every disassembly.

: Genuine CVT fluid

# DIFFERENTIAL SIDE OIL SEAL

< REMOVAL AND INSTALLATION >

[CVT: RE0F10B]

## AWD : Removal and Installation

INFOID:000000009752683

### REMOVAL

#### NOTE:

Cap or plug openings to prevent fluid from spilling.

1. Remove the left front drive shaft. Refer to [FAX-20, "LEFT SIDE : Removal and Installation"](#).
2. Remove the transfer assembly. Refer to [DLN-93, "Removal and Installation"](#).
3. Use oil seal remover or a similar means and remove the differential side oil seal.

#### CAUTION:

**When removing the differential side oil seal, be careful not to scratch the oil seal mounting surfaces of the transaxle case and converter housing.**

### INSTALLATION

Note the following, and install in the reverse order of removal.

#### CAUTION:

- Never reuse differential side oil seal.
- Apply Genuine CVT fluid to the differential side oil seal lip and around the oil seal.
- When inserting the drive shaft, be sure to use a protector (SST: KV38107900).

Use a drift (commercial service tool) and drive the differential side oil seal in until the amount of oil seal projection from the case edge matches dimensions (C) and (D).

#### CAUTION:

**Be careful not to scratch the lip of the differential side oil seal when press-fitting it.**

- A : Transaxle case side  
B : Converter housing side

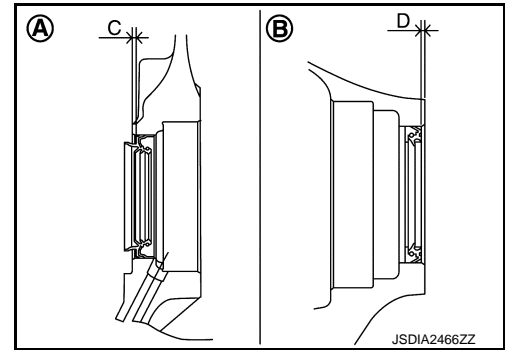

**Dimension "C" :Height difference from case end surface is within  $1.8 \pm 0.5$  mm ( $0.071 \pm 0.020$  in).**

**Dimension "D" :Height difference from case end surface is within  $1.0 \pm 0.5$  mm ( $0.039 \pm 0.020$  in).**

#### NOTE:

The reference is the pull-in direction of the differential side oil seal.

Drift to be used:

Location	Commercial Service Tools
Transaxle case side	Commercial service tool with outer dia. 54 mm (2.13 in) and inner dia. 50 mm (1.97 in)
Converter housing side	Commercial service tool with outer dia. 60 mm (2.36 in)

## AWD : Inspection

INFOID:000000009752684

### INSPECTION AFTER INSTALLATION

Check for CVT fluid leakage and CVT fluid level. Refer to [TM-305, "Inspection"](#).

# OIL PUMP FITTING BOLT

< REMOVAL AND INSTALLATION >

[CVT: RE0F10B]

## OIL PUMP FITTING BOLT

### Description

INFOID:000000009752685

Replace the oil pump fitting bolt and the O-ring if oil leakage or exudes from the oil pump fitting bolt.

### Exploded View

INFOID:000000009752686

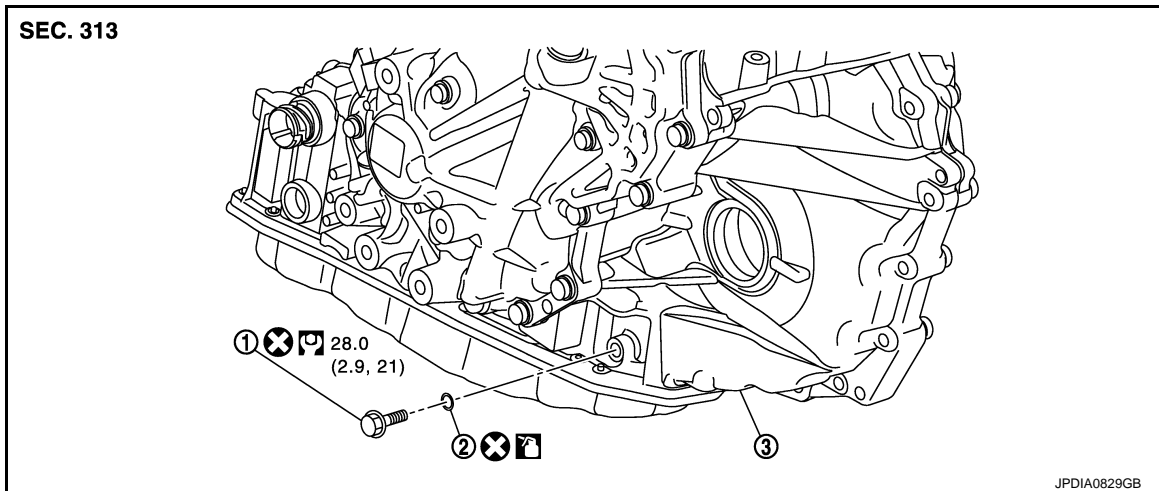

1. Oil pump fitting bolt

2. O-ring

3. Transaxle assembly

⊗ : Always replace after every disassembly.

Ⓒ : N·m (kg-m, ft-lb)

👉 : Apply CVT fluid

### Removal and Installation

INFOID:000000009752687

#### REMOVAL

1. Remove Oil pump fitting bolt (1) from transaxle assembly.
2. Remove O-ring from oil pump fitting bolt.

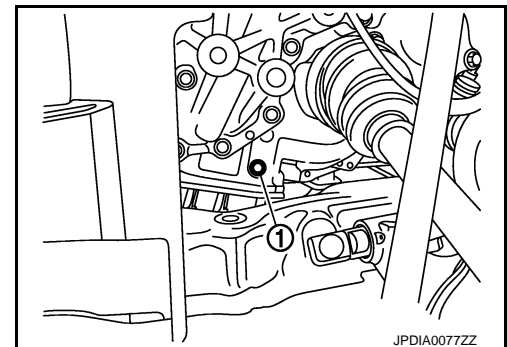

#### INSTALLATION

Note the following, and install in the reverse order of removal.

#### CAUTION:

- Never reuse O-ring.
- Apply CVT fluid to O-ring.

#### Inspection

INFOID:000000009752688

#### INSPECTION AFTER INSTALLATION

Check for CVT fluid leakage and CVT fluid level. Refer to [TM-305, "Inspection"](#).

# WATER HOSE

< REMOVAL AND INSTALLATION >

[CVT: RE0F10B]

## WATER HOSE

### Exploded View

INFOID:000000009752689

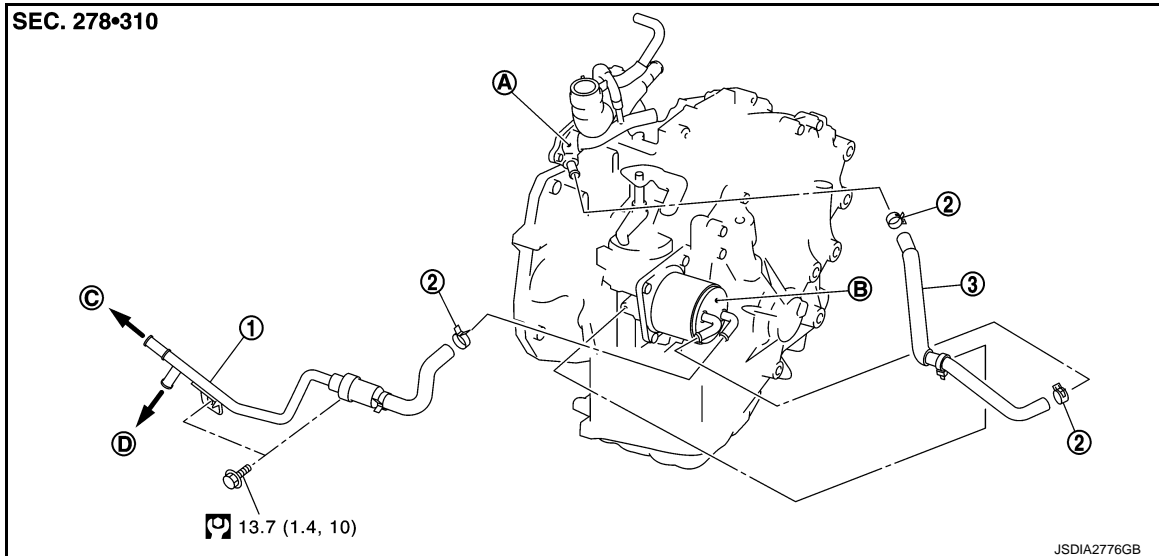

- |                               |                   |                          |
|-------------------------------|-------------------|--------------------------|
| 1. Heater thermostat assembly | 2. Hose clamp     | 3. Water hose            |
| A. Water outlet               | B. CVT oil warmer | C. To thermostat housing |
| D. To oil cooler              |                   |                          |

 : N·m (kg·m, ft·lb)

## Removal and Installation

INFOID:000000009752690

### REMOVAL

#### **WARNING:**

Never remove the radiator cap when the engine is hot. Serious burns could occur from high pressure coolant escaping from the radiator.

#### **CAUTION:**

Perform these steps after the coolant temperature has cooled sufficiently.

1. Remove the battery. Refer to [PG-99, "Removal and Installation"](#).
2. Remove the ECM and bracket as a set.
3. Remove the water hose.
4. Remove the heater thermostat.

### INSTALLATION

Note the following, and Install in the reverse order of removal.

- Refer to the following when installing water hoses.

Water hose (1)	Installation side tube (2)	Direction of paint mark	Hose insertion depth "L"
Water hose	Water outlet	Upward	A: 27 mm (1.06 in) [End reaches the 2-stage bulge.]
	CVT oil warmer	Leftward	B: 27 mm (1.06 in) [End reaches the tube bend R position].]
Heater thermostat assembly	CVT oil warmer	Leftward	



# WATER HOSE

< REMOVAL AND INSTALLATION >

[CVT: RE0F10B]

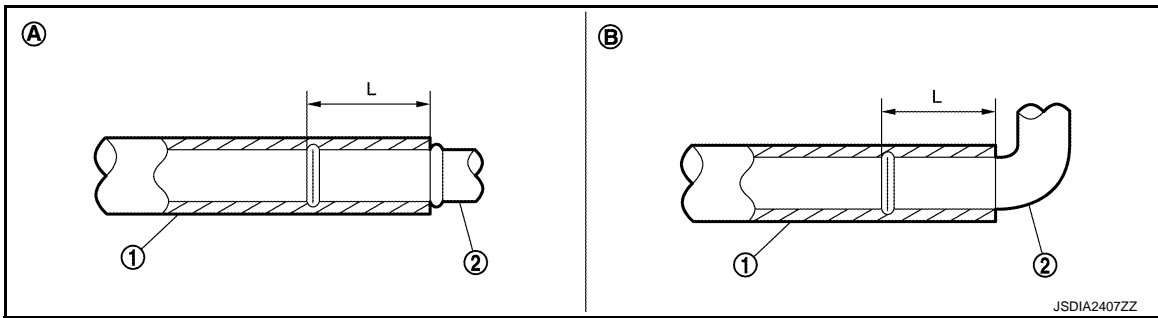

- Refer to the followings when installing hose clamp.

**CAUTION:**

**Hose clamp should not interfere with the bulge of fluid cooler tube.**

Water hose (1)	Installation side tube (2)	Hose clamp (3)	
		Direction of tab	Clamping position
Water hose	Water outlet	Backward	A: 5 – 7 mm (0.20 – 0.28 in) (L) from hose end
	CVT oil warmer	Upward	
Heater thermostat assembly	CVT oil warmer	Upward	B: Align with the end of paint mark (C)

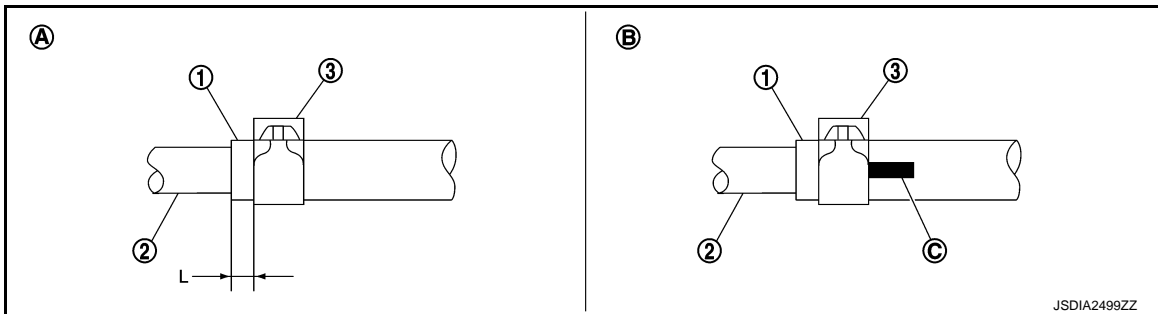

## Inspection

INFOID:000000009752691

### INSPECTION AFTER REMOVAL

#### Heater Thermostat

- Fully immerse the heater thermostat (1) in a container (A) filled with water. Continue heating the water while stirring.
- Continue heating the heater thermostat for 5 minutes or more after bringing the water to a boil.
- Quickly take the heater thermostat out of the hot water, measure the heater thermostat within 10 seconds.

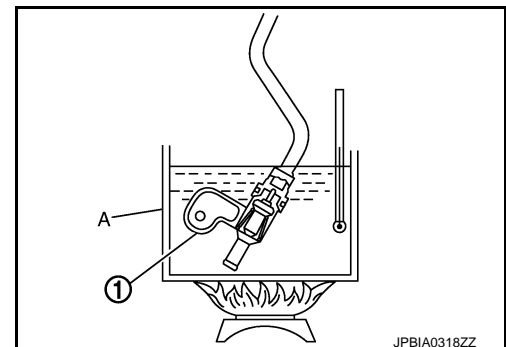

## WATER HOSE

[CVT: RE0F10B]

### < REMOVAL AND INSTALLATION >

- Place dial indicator (A) on the pellet (B) and measure the elongation from the initial state.

**Standard** : Refer to [TM-348, "Heater Thermostat"](#).

- If out of standard, replace heater thermostat.

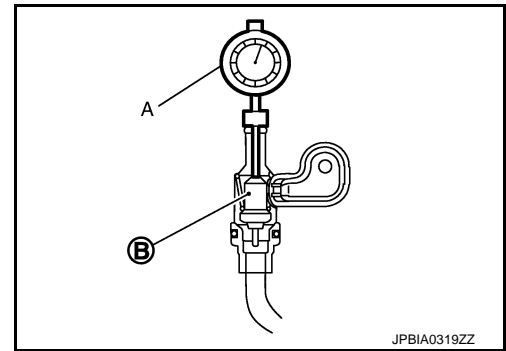

### INSPECTION AFTER INSTALLATION

Start the engine, and check the joints for coolant leakage. Refer to [TM-305, "Inspection"](#).



# TRANSAXLE ASSEMBLY

[CVT: RE0F10B]

## < UNIT REMOVAL AND INSTALLATION >

Cap or cover any transaxle openings to prevent transaxle fluid from spilling.

1. Remove the battery. Refer to [PG-99, "Removal and Installation"](#).
2. Drain engine coolant. Refer to [CO-8, "Draining"](#).
3. Remove the air duct and air cleaner case. Refer to [EM-25, "Removal and Installation"](#).
4. Remove air breather hose. Refer to [TM-321, "Removal and Installation"](#).
5. Remove the ECM and bracket as a set.
6. Remove CVT fluid level gauge.
7. Remove CVT fluid charging pipe from transaxle assembly.
8. Remove O-ring from CVT fluid charging pipe.
9. Disconnect following harness connector and wire harness.
  - CVT unit harness connector (A).
  - Primary speed sensor harness connector (B).
  - Secondary speed sensor harness connector (C).
  - Transmission range switch connector (D).
10. Remove harness and clip from the transaxle assembly.
11. Remove water hose. Refer to [TM-336, "Removal and Installation"](#).
12. Remove control cable from transaxle assembly. Refer to [TM-311, "Removal and Installation"](#).
13. Remove starter motor. Refer to [STR-37, "Removal and Installation"](#).
14. Turn crankshaft, and remove the four tightening nuts (←) for drive plate and torque converter.

**CAUTION:**

**When turning crankshaft, turn it clockwise as viewed from the front of the engine.**

15. Remove exhaust front tube. Refer to [EX-5, "Exploded View"](#).
16. Remove front drive shafts. Refer to [FAX-20, "LEFT SIDE : Removal and Installation"](#) (left side), [FAX-22, "RIGHT SIDE : Removal and Installation"](#) (right side).
17. Remove front suspension member from vehicle. Refer to [FSU-17, "Removal and Installation"](#).
18. Support transaxle assembly with a transmission jack.

**CAUTION:**

**When setting the transmission jack, be careful not to collide against the drain plug.**

19. Support engine assembly with a transmission jack.

**CAUTION:**

**When setting the transmission jack, be careful not to collide against the drain plug.**

20. Remove engine mounting insulator (LH). Refer to [EM-59, "2WD : Exploded View"](#).
21. Remove bolts fixing transaxle assembly to engine assembly.
22. Remove transaxle assembly from vehicle.

**CAUTION:**

- Secure torque converter to prevent it from dropping.
- Secure transaxle assembly to a transmission jack.

23. Remove heater thermostat. Refer to [TM-336, "Removal and Installation"](#).

## INSTALLATION

Note following, and install in the reverse order of removal.

**CAUTION:**

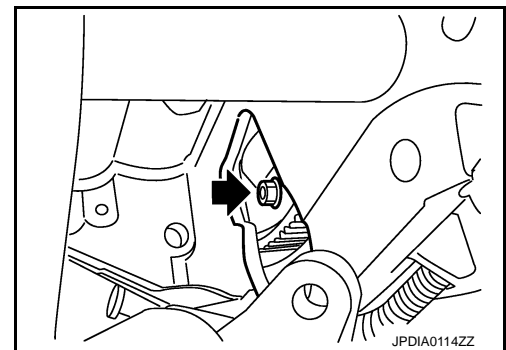
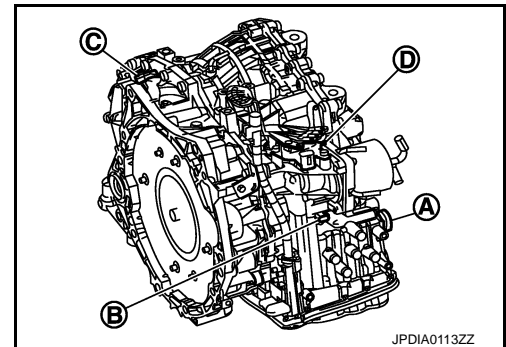

# TRANSAXLE ASSEMBLY

< UNIT REMOVAL AND INSTALLATION >

[CVT: RE0F10B]

- Check fitting of dowel pin (←) when installing transaxle assembly to engine assembly.

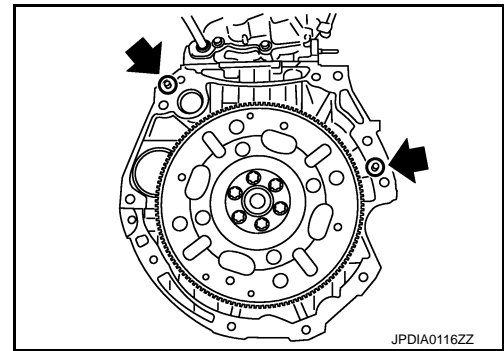

- When installing transaxle assembly to the engine assembly, attach the fixing bolts in accordance with the following.

1. Rotate torque converter to align a torque converter stud bolt with the mounting position of starter motor.
2. Rotate drive plate to align a torque converter stud bolt insertion hole of drive plate with service hole.
3. Install transaxle to engine.

**CAUTION:**

**Be careful not to strike the drive plate when inserting torque converter stud bolts to drive plate holes.**

4. Tighten the fixing bolts in accordance with the following.

Bolt position	A	B
Insertion direction	Transaxle to engine	Engine to transaxle
Number of bolts	2	7
Bolt length mm (in)	55 (2.17)	50 (1.97)
Tightening torque N·m (kg·m, ft·lb)	62 (6.3, 46)	

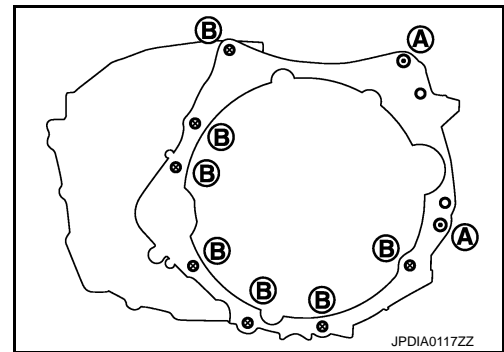

5. After tighten the torque converter nuts (←) temporarily, tighten the torque converter nuts to the specified torque.

**CAUTION:**

- When turning crankshaft, turn it clockwise as viewed from the crankshaft pulley side.
- When tightening the torque converter nuts after fixing the crankshaft pulley bolts, confirm the tightening torque of the crankshaft pulley mounting bolts. Refer to [EM-73, "Exploded View"](#).
- Rotate crankshaft several turns and check that transaxle rotates freely without binding after converter is installed to drive plate.

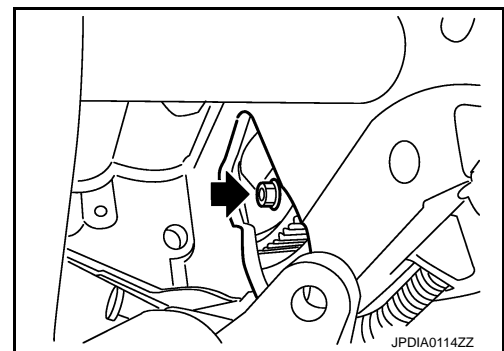

## 2WD : Inspection and Adjustment

INFOID:000000009752694

### INSPECTION BEFORE INSTALLATION

After inserting a torque converter to the CVT, check dimension (A) with in the reference value limit.

- B : Scale
- C : Straightedge

**Dimension (A) : Refer to [TM-348, "Torque Converter"](#).**

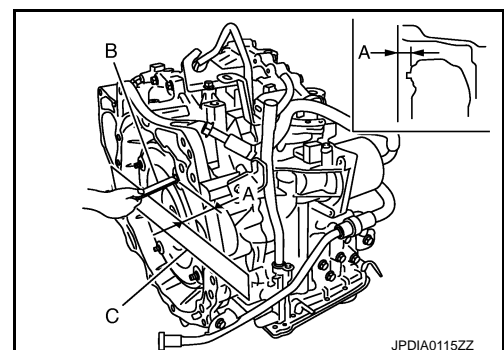



# TRANSAXLE ASSEMBLY

< UNIT REMOVAL AND INSTALLATION >

[CVT: RE0F10B]

## CAUTION:

- Perform this step engine is cold.
- When replacing TCM and transaxle assembly simultaneously, replace transaxle assembly first and then replace TCM.

## NOTE:

Cap or cover any transaxle openings to prevent transaxle fluid from spilling.

1. Remove the battery. Refer to [PG-99. "Removal and Installation"](#).
2. Drain engine coolant. Refer to [CO-8. "Draining"](#).
3. Remove the air duct and air cleaner case. Refer to [EM-25. "Removal and Installation"](#).
4. Remove air breather hose. Refer to [TM-321. "Removal and Installation"](#).
5. Remove the ECM and bracket as a set.
6. Remove CVT fluid level gauge.
7. Remove CVT fluid charging pipe from transaxle assembly.
8. Remove O-ring from CVT fluid charging pipe.
9. Disconnect following harness connector and wire harness.
  - CVT unit harness connector (A).
  - Primary speed sensor harness connector (B).
  - Secondary speed sensor harness connector (C).
  - Transmission range switch connector (D).
10. Remove harness and clip from the transaxle assembly.
11. Remove water hose. Refer to [TM-336. "Removal and Installation"](#).
12. Remove control cable from transaxle assembly. Refer to [TM-311. "Removal and Installation"](#).
13. Remove starter motor. Refer to [STR-37. "Removal and Installation"](#).

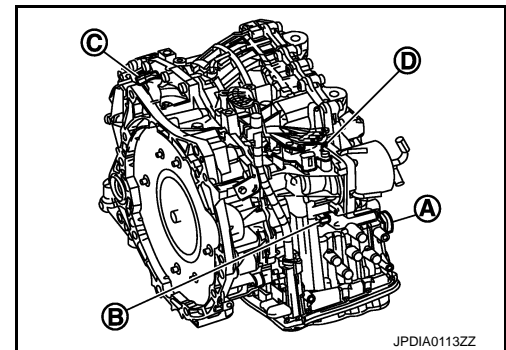

14. Turn crankshaft, and remove the four tightening nuts (↻) for drive plate and torque converter.

## CAUTION:

**When turning crankshaft, turn it clockwise as viewed from the front of the engine.**

15. Remove exhaust front tube. Refer to [EX-5. "Exploded View"](#).
16. Separate the propeller shaft. Refer to [DLN-123. "Removal and Installation"](#).
17. Remove front drive shafts. Refer to [FAX-20. "LEFT SIDE : Removal and Installation"](#) (left side), [FAX-22. "RIGHT SIDE : Removal and Installation"](#) (right side).

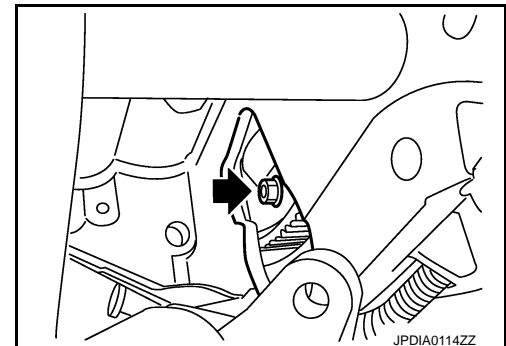

18. Remove front suspension member from vehicle. Refer to [FSU-17. "Removal and Installation"](#).
19. Remove transfer assembly from transaxle assembly with power tool. Refer to [DLN-93. "Removal and Installation"](#).

20. Support transaxle assembly with a transmission jack.

## CAUTION:

**When setting the transmission jack, be careful not to collide against the drain plug.**

21. Support engine assembly with a transmission jack.

## CAUTION:

**When setting the transmission jack, be careful not to collide against the drain plug.**

22. Remove engine mounting insulator (LH). Refer to [EM-65. "AWD : Exploded View"](#).
23. Remove bolts fixing transaxle assembly to engine assembly.
24. Remove transaxle assembly from vehicle.

## CAUTION:

- Secure torque converter to prevent it from dropping.
- Secure transaxle assembly to a transmission jack.

25. Remove heater thermostat. Refer to [TM-336. "Removal and Installation"](#).

INSTALLATION

# TRANSAXLE ASSEMBLY

## < UNIT REMOVAL AND INSTALLATION >

[CVT: RE0F10B]

Note following, and install in the reverse order of removal.

**CAUTION:**

- Check fitting of dowel pin (↔) when installing transaxle assembly to engine assembly.

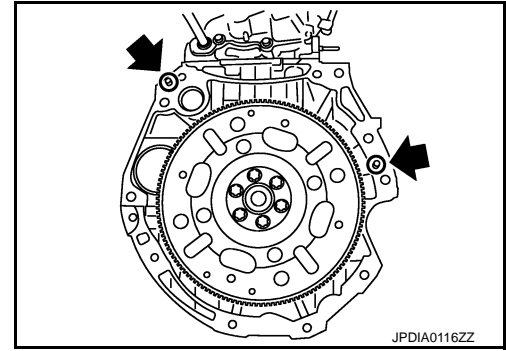

- When installing transaxle assembly to the engine assembly, attach the fixing bolts in accordance with the following.

1. Rotate torque converter to align a torque converter stud bolt with the mounting position of starter motor.
2. Rotate drive plate to align a torque converter stud bolt insertion hole of drive plate with service hole.
3. Install transaxle to engine.

**CAUTION:**

**Be careful not to strike the drive plate when inserting torque converter stud bolts to drive plate holes.**

4. Tighten the fixing bolts in accordance with the following.

Bolt position	A	B
Insertion direction	Transaxle to engine	Engine to transaxle
Number of bolts	2	6
Bolt length mm (in)	55 (2.17)	50 (1.97)
Tightening torque N·m (kg-m, ft-lb)	62 (6.3, 46)	

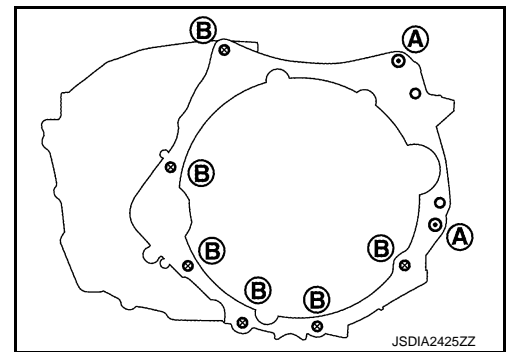

5. After tighten the torque converter nuts (↔) temporarily, tighten the torque converter nuts to the specified torque.

**CAUTION:**

- When turning crankshaft, turn it clockwise as viewed from the crankshaft pulley side.
- When tightening the torque converter nuts after fixing the crankshaft pulley bolts, confirm the tightening torque of the crankshaft pulley mounting bolts. Refer to [EM-73, "Exploded View"](#).
- Rotate crankshaft several turns and check that transaxle rotates freely without binding after converter is installed to drive plate.

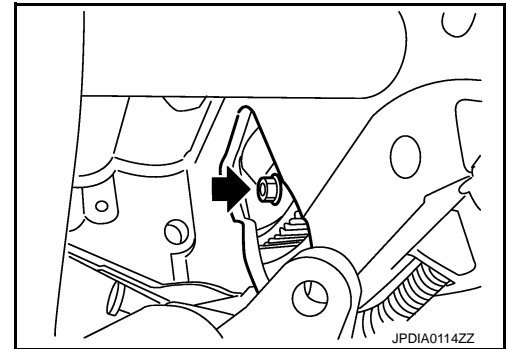

AWD : Inspection and Adjustment

INFOID:000000009752697

INSPECTION BEFORE INSTALLATION



# TRANSAXLE ASSEMBLY

## < UNIT REMOVAL AND INSTALLATION >

[CVT: RE0F10B]

After inserting a torque converter to the CVT, check dimension (A) with in the reference value limit.

- B : Scale
- C : Straightedge

**Dimension (A)** : Refer to [TM-348, "Torque Converter"](#).

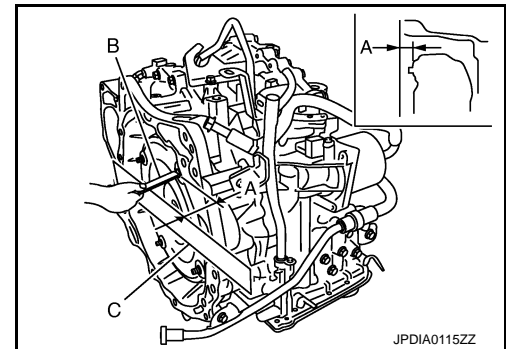

### INSPECTION AFTER INSTALLATION

- Check for CVT fluid leakage and check CVT fluid level. Refer to [TM-305, "Inspection"](#).
- Check CVT position. Refer to [TM-226, "Inspection and Adjustment"](#).
- Start and warm up the engine. Visually check that there is no leakage of engine coolant and CVT fluid.

### ADJUSTMENT AFTER INSTALLATION

Perform "ADDITIONAL SERVICE WHEN REPLACE CONTROL VALVE OR TRANSAXLE ASSEMBLY". Refer to [TM-214, "Description"](#).

# TORQUE CONVERTER AND CONVERTER HOUSING OIL SEAL

< UNIT DISASSEMBLY AND ASSEMBLY >

[CVT: RE0F10B]

## UNIT DISASSEMBLY AND ASSEMBLY

### TORQUE CONVERTER AND CONVERTER HOUSING OIL SEAL

Exploded View

INFOID:000000009752698

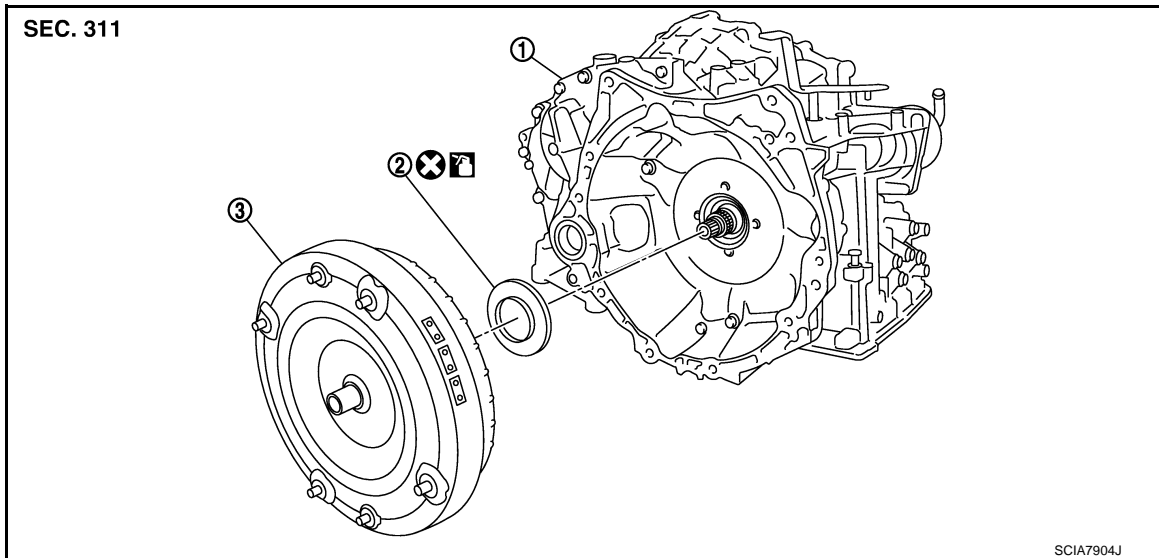

1. Transaxle assembly                      2. Converter housing oil seal                      3. Torque converter

⊗ : Always replace after every disassembly.

🔧 : Apply CVT fluid

### Disassembly

INFOID:000000009752700

1. Remove transaxle assembly. Refer to [TM-342, "AWD : Removal and Installation"](#).
2. Remove torque converter from transaxle assembly.

**CAUTION:**

**Never damage bush on the inside of torque converter sleeve when removing torque converter.**

3. Remove converter housing oil seal using a flat-bladed screwdriver.

**CAUTION:**

**Be careful not to scratch converter housing.**

### Assembly

INFOID:000000009752700

Note the following, and install in the reverse order of removal.

- Drive converter housing oil seal (1) evenly using a drift (A) (commercial service tool) so that converter housing oil seal protrudes by the dimension (B) respectively.

Unit: mm (in)	
Commercial service tool: A	Outer diameter: 65 (2.56)
	Inner diameter: 60 (2.36)

2 : Transaxle assembly

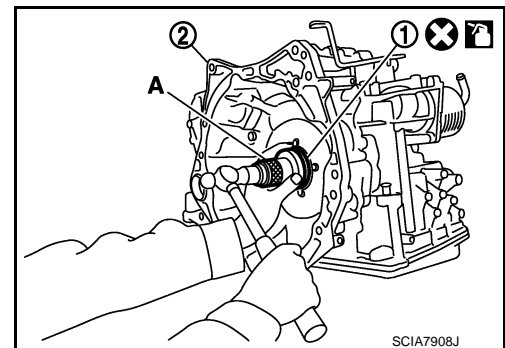

# TORQUE CONVERTER AND CONVERTER HOUSING OIL SEAL

< UNIT DISASSEMBLY AND ASSEMBLY >

[CVT: RE0F10B]

Unit: mm (in)	
Dimension B	1.0 ± 0.5 (0.039 ± 0.020)

**NOTE:**

Converter housing oil seal pulling direction is used as the reference.

- After completing installation, check for CVT fluid leakage and CVT fluid level. Refer to [TM-305, "Inspection"](#).

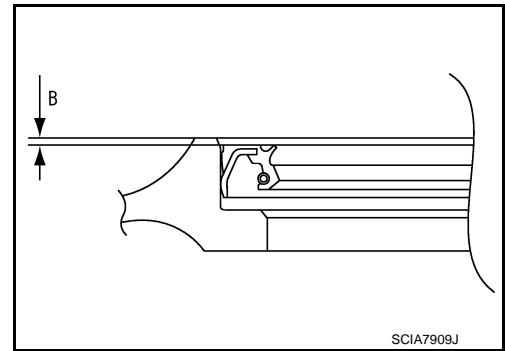

- Attach the pawl (A) of the torque converter to the drive sprocket hole (B) on the transaxle assembly side.

**CAUTION:**

- Rotate the torque converter for installing torque converter.
- Never damage the bushing inside the torque converter sleeve when installing the converter housing oil seal.

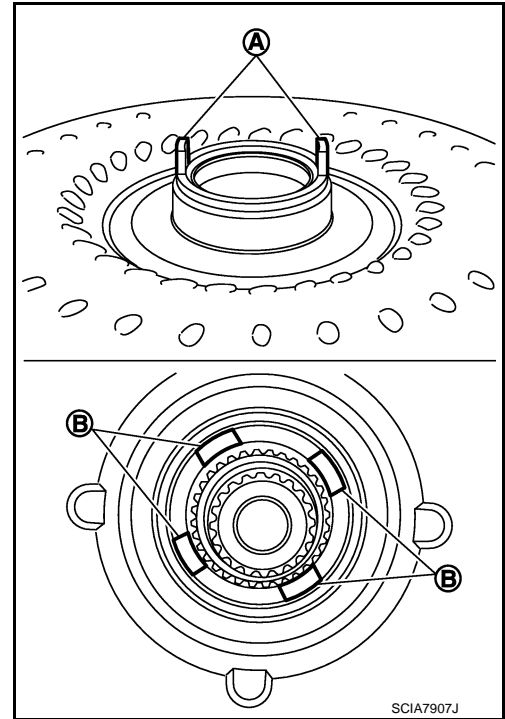

## Inspection

INFOID:000000009752701

### INSPECTION AFTER INSTALLATION

- After inserting a torque converter to the CVT, check dimension (A) with in the reference value limit.

- B : Scale
- C : Straightedge

**Dimension (A)** : Refer to [TM-348, "Torque Converter"](#).

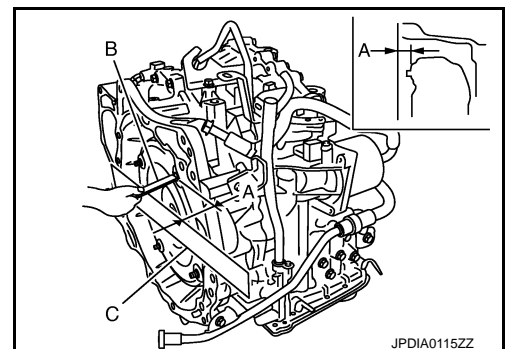

## SERVICE DATA AND SPECIFICATIONS (SDS)

< SERVICE DATA AND SPECIFICATIONS (SDS)

[CVT: RE0F10B]

# SERVICE DATA AND SPECIFICATIONS (SDS)

## SERVICE DATA AND SPECIFICATIONS (SDS)

### General Specification

INFOID:000000009752702

Applied model	Engine	MR16DDT	
	Axle	2WD	AWD
Transaxle model		RE0F10B	
Transmission gear ratio	D range	2.349 – 0.394	
	Reverse	1.750	
	Final drive	5.798	
Recommended fluid and fluid capacity		Refer to <a href="#">MA-10. "Fluids and Lubricants"</a> .	

### Shift Characteristics

INFOID:000000009752703

Numerical value data are reference values.

Unit: rpm

Throttle position	Shift pattern	CVT input speed	
		At 40 km/h (25 MPH)	At 60 km/h (37 MPH)
2/8	"D" position	1,500 – 3,100	1,600 – 3,400
	ECO mode*	1,500 – 2,400	1,600 – 2,500
8/8	"D" position	3,300 – 4,200	4,300 – 5,200
	ECO mode*	3,300 – 4,200	4,300 – 5,200

\*: With Integrated Control System

#### NOTE:

Lock-up clutch is engaged when vehicle speed is approximately 18 km/h (11 MPH) to 90 km/h (56 MPH).

### Stall Speed

INFOID:000000009752704

Stall speed	3,000 – 3,500 rpm
-------------	-------------------

### Line Pressure

INFOID:000000009752705

Unit: kPa (bar, kg/cm<sup>2</sup>, psi)

Engine speed	Line pressure
	"R" and "D" positions
At idle	750 (7.50, 7.65, 108.8)
At stall	5,700 (57.00, 58.14, 826.5)*

\*: Reference values

### Torque Converter

INFOID:000000009752706

Dimension between end of converter housing and torque converter	14.4 mm (0.567 in)
---	--------------------

### Heater Thermostat

INFOID:000000009752707

Standard

Valve opening temperature	69 – 73°C (156 – 163°F)
---------------------------	-------------------------

# SERVICE DATA AND SPECIFICATIONS (SDS)

< SERVICE DATA AND SPECIFICATIONS (SDS)

[CVT: RE0F10B]

Maximum valve lift	5.0 mm/85°C (0.197 in/185°F)
Valve closing temperature	65°C (149°F)

A

B

C

TM

E

F

G

H

I

J

K

L

M

N

O

P