

ENGINE LUBRICATION & COOLING SYSTEMS

SECTION LC

GI

MA

EM

LC

EF &
EC

FE

AT

PD

FA

RA

BR

ST

BF

HA

EL

CONTENTS

PRECAUTIONS AND PREPARATION	2	Cooling Circuit	7
Supplemental Restraint System "AIR BAG" and "SEAT BELT PRE-TENSIONER"	2	System Check.....	7
Liquid Gasket Application Procedure	2	Water Pump.....	8
Special Service Tools.....	2	Thermostat	10
ENGINE LUBRICATION SYSTEM	3	Radiator	12
Lubrication Circuit.....	3	Cooling Fan	13
Oil Pressure Check.....	4	SERVICE DATA AND SPECIFICATIONS (S.D.S.)	14
Oil Pump.....	5	Engine Lubrication System.....	14
ENGINE COOLING SYSTEM	7	Engine Cooling System	14

PRECAUTIONS AND PREPARATION

Supplemental Restraint System “AIR BAG” and “SEAT BELT PRE-TENSIONER”

The Supplemental Restraint System “Air Bag” and “Seat Belt Pre-tensioner” help to reduce the risk or severity of injury to the driver and front passenger in a frontal collision. The Supplemental Restraint System consists of air bags (located in the center of the steering wheel and on the instrument panel on the passenger side), seat belt pre-tensioners, sensors, a control unit, warning lamp, wiring harness and spiral cable. Information necessary to service the system safely is included in the **BF** section.

WARNING:

- To avoid rendering the SRS inoperative, which could lead to personal injury or death in the event of a severe frontal collision, all maintenance must be performed by an authorized INFINITI dealer.
- Improper maintenance, including incorrect removal and installation of the SRS, can lead to personal injury caused by unintentional activation of the system.
- All SRS air bag electrical wiring harnesses and connectors are covered with yellow outer insulation. Do not use electrical test equipment on any circuit related to the SRS SYSTEM.

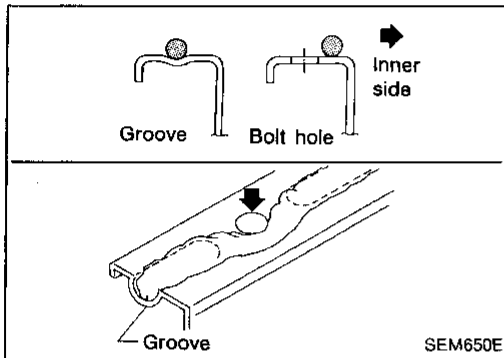

Liquid Gasket Application Procedure

- a. Before applying liquid gasket, use a scraper to remove all traces of old liquid gasket from mating surfaces and grooves, and then completely clean any oil stains.
- b. Apply a continuous bead of liquid gasket to mating surfaces. (Use Genuine Liquid Gasket or equivalent.)
 - Be sure liquid gasket is 3.5 to 4.5 mm (0.138 to 0.177 in) wide (for oil pan).
 - Be sure liquid gasket is 2.0 to 3.0 mm (0.079 to 0.118 in) wide (in areas except oil pan).
- c. Apply liquid gasket to inner side as shown at the left. (Assembly should be done within 5 minutes after coating.)
- d. Wait 30 minutes before refilling engine oil and coolant.

Special Service Tools

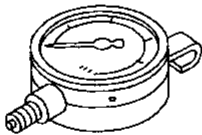
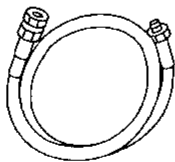
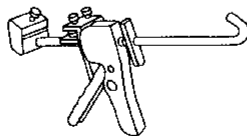
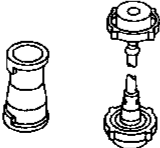
Tool number (Kent-Moore No.) Tool name	Description	
ST25051001 (J25695-1) Oil pressure gauge	 NT050	
ST25052000 (J25695-2) Hose	 NT051	Adapting oil pressure gauge to cylinder block
WS39930000 (—) Tube presser	 NT052	Pressing the tube of liquid gasket
EG17650301 (J33984-A) Radiator cap tester adapter	 NT053	Adapting radiator cap tester to radiator filler neck

ENGINE LUBRICATION SYSTEM

Lubrication Circuit

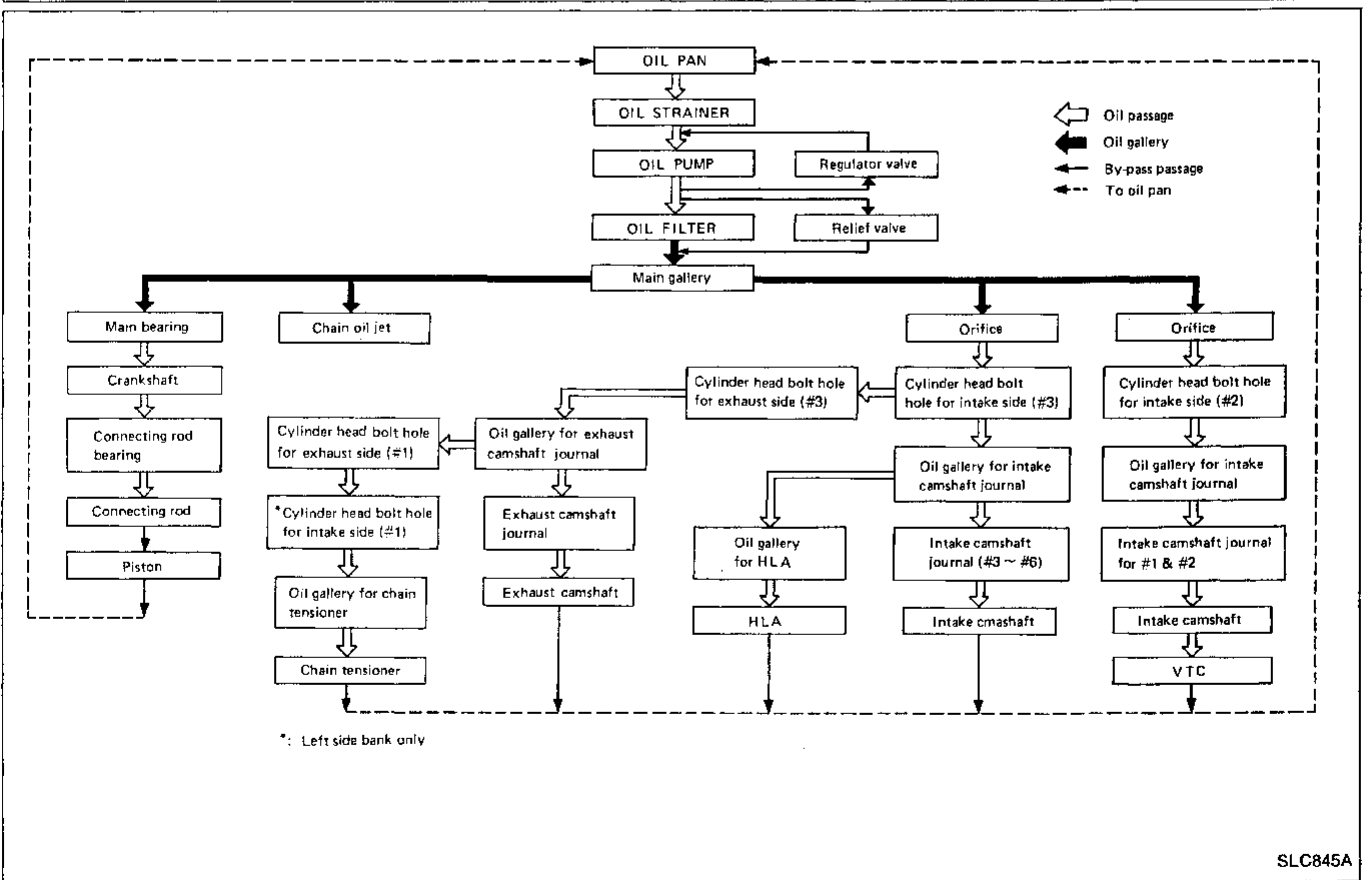
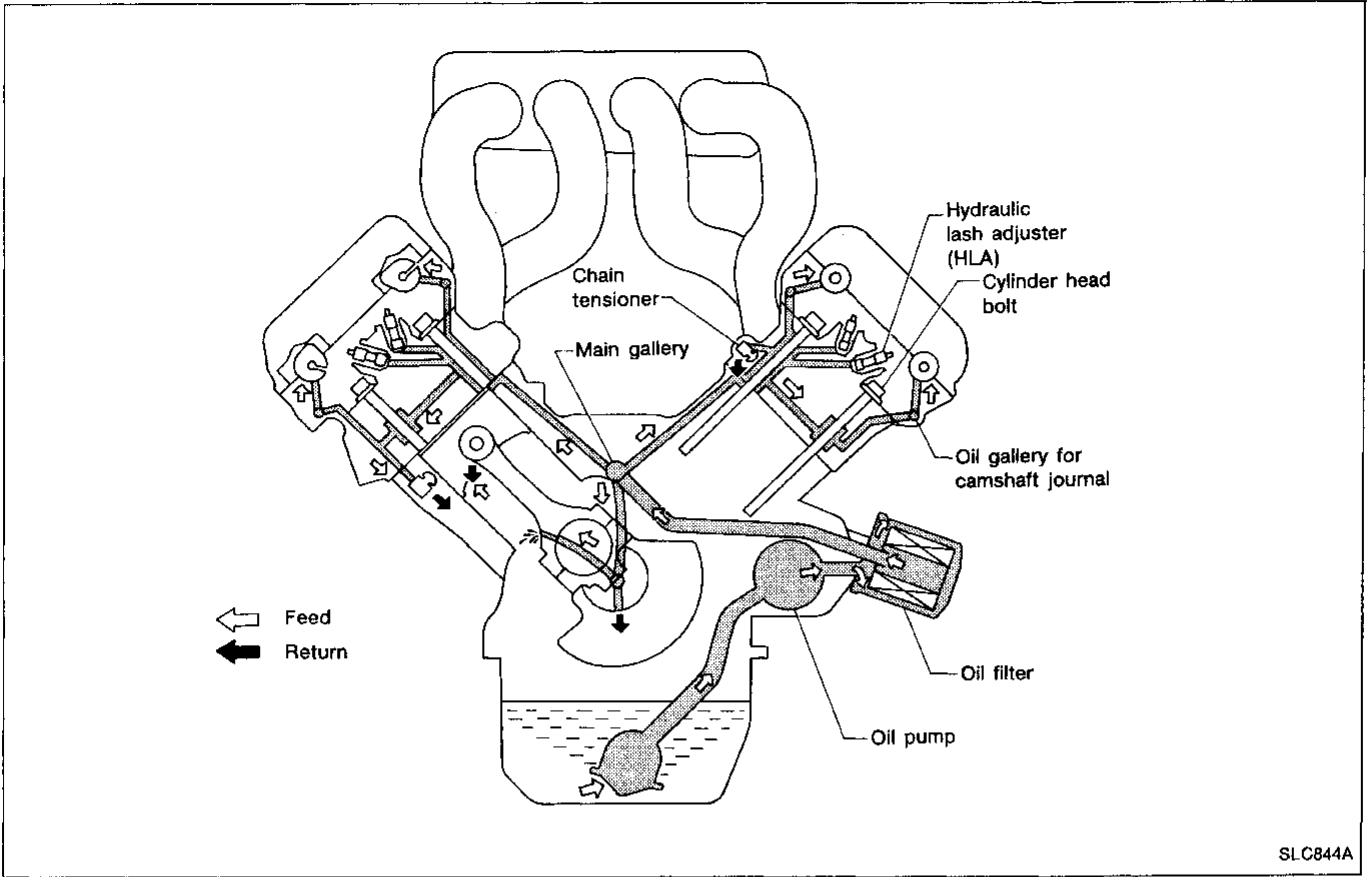

GI
MA
EM
LC
EF & EC
FE
AT
PD
FA
RA
BR
ST
BF
HA
EL

Oil Pressure Check

WARNING:

- Be careful not to burn yourself, as the engine and oil may hot.
- Oil pressure check should be done in "Neutral position".

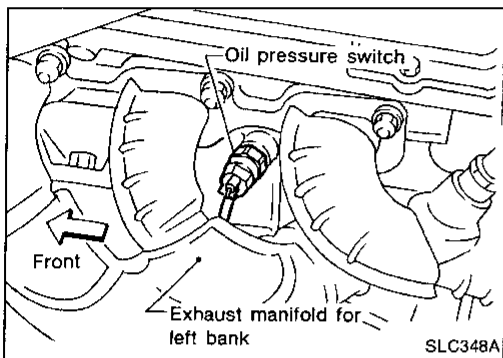

1. Check oil level.
2. Remove oil pressure switch.

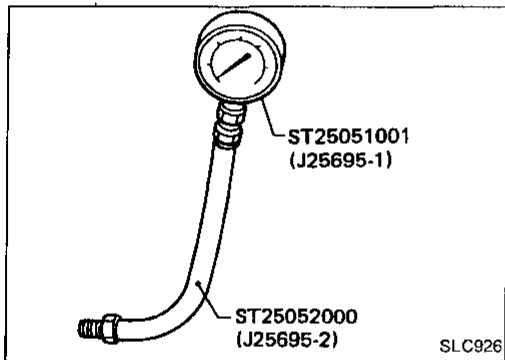

3. Install pressure gauge.
4. Start engine and warm it up to normal operating temperature.
5. Check oil pressure with engine running under no-load.

Engine speed rpm	Approximate discharge pressure kPa (kg/cm ² , psi)
Idle speed	More than 98 (1.0, 14)
3,000	461 - 559 (4.7 - 5.7, 67 - 81)

If difference is extreme, check oil passage and oil pump for oil leaks.

6. Install oil pressure switch with sealant.

Oil Pump

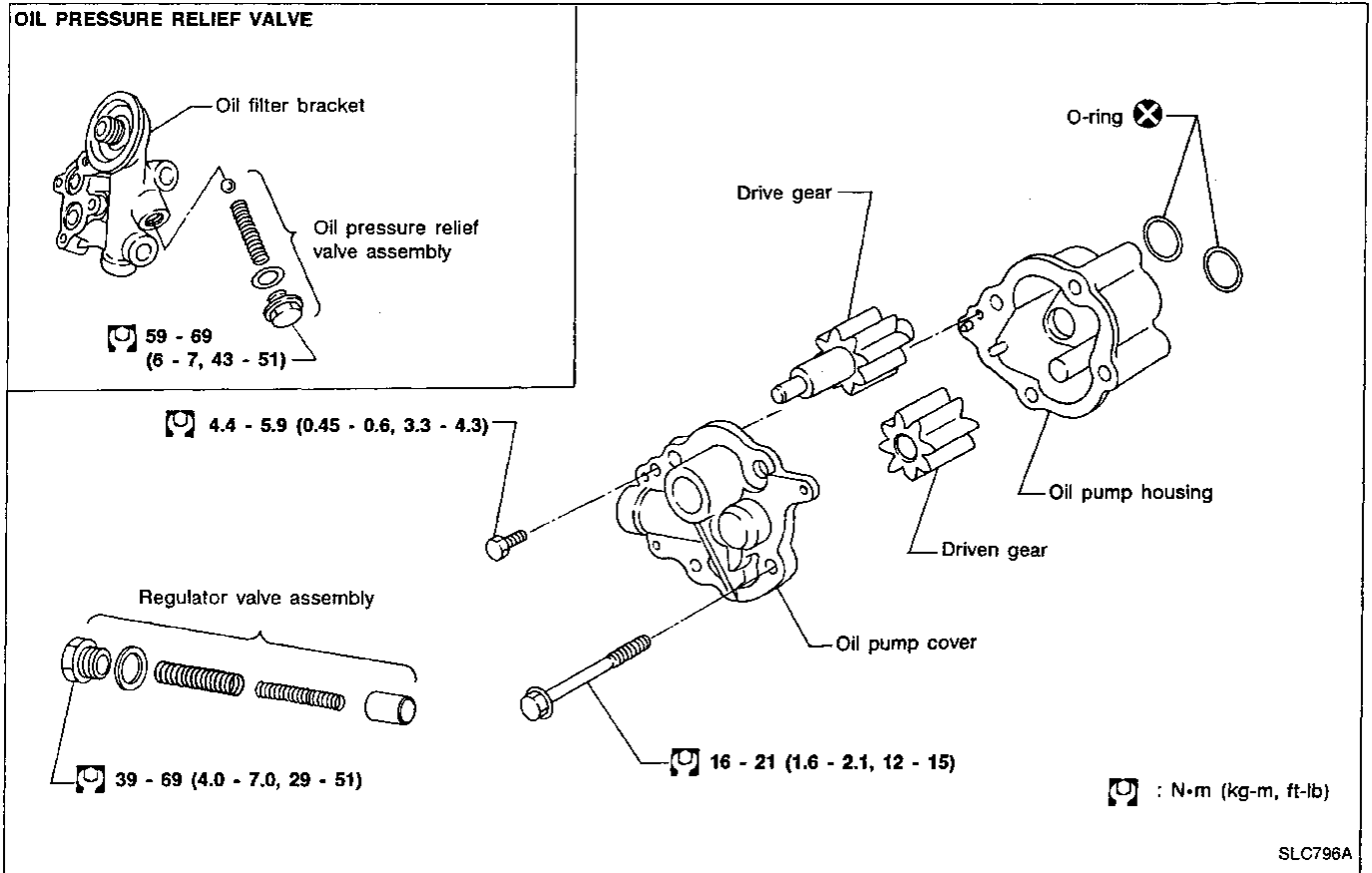

INSPECTION

If it exceeds the limit, replace gear set or entire oil pump assembly.

Standard clearance:

Unit: mm (in)

Drive shaft to cover and housing: (C)	0.024 - 0.069 (0.0009 - 0.0027)
Driven gear to driven shaft : (F)	0.025 - 0.064 (0.0010 - 0.0025)
Drive and driven gear to housing: (B)	0.08 - 0.130 (0.0031 - 0.0051)
Drive and driven gear to housing: (H)	0.125 - 0.245 (0.0049 - 0.0096)

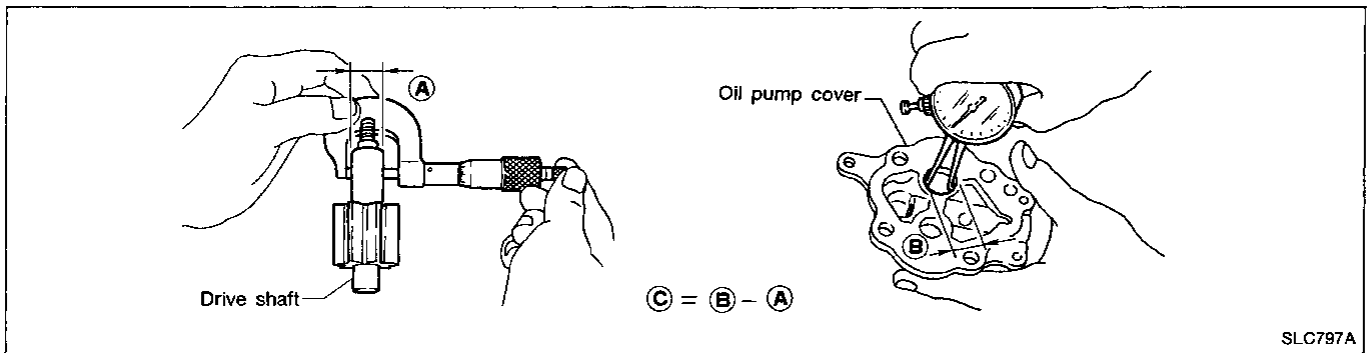

ENGINE LUBRICATION SYSTEM

Oil Pump (Cont'd)

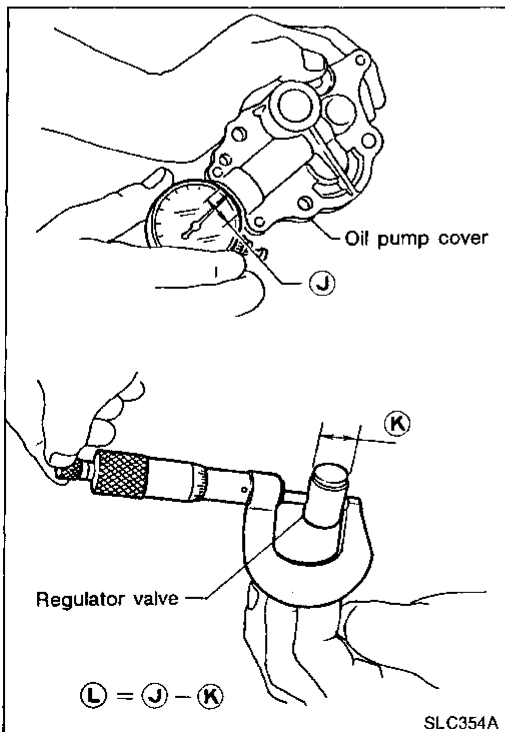
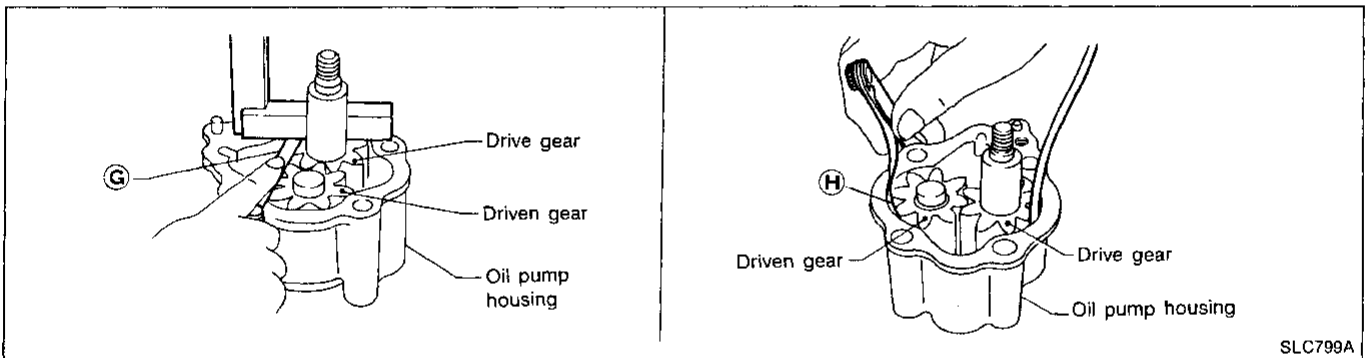
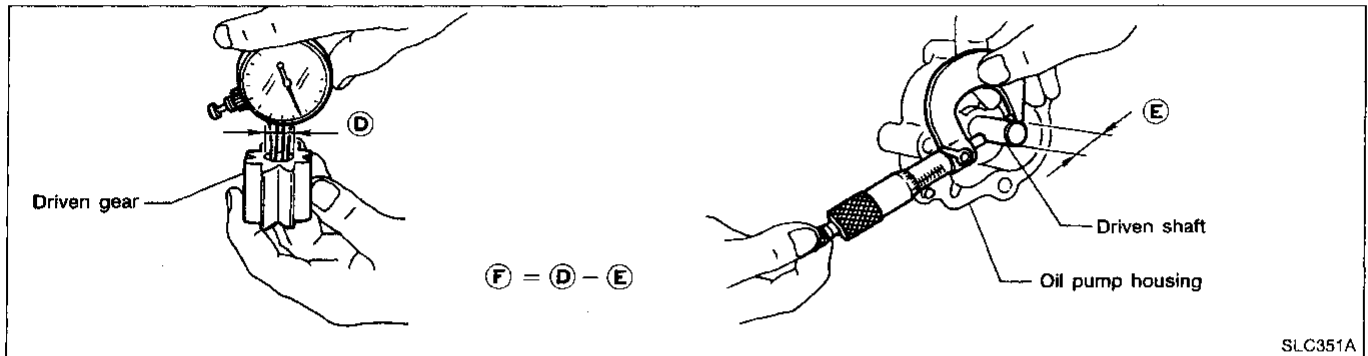
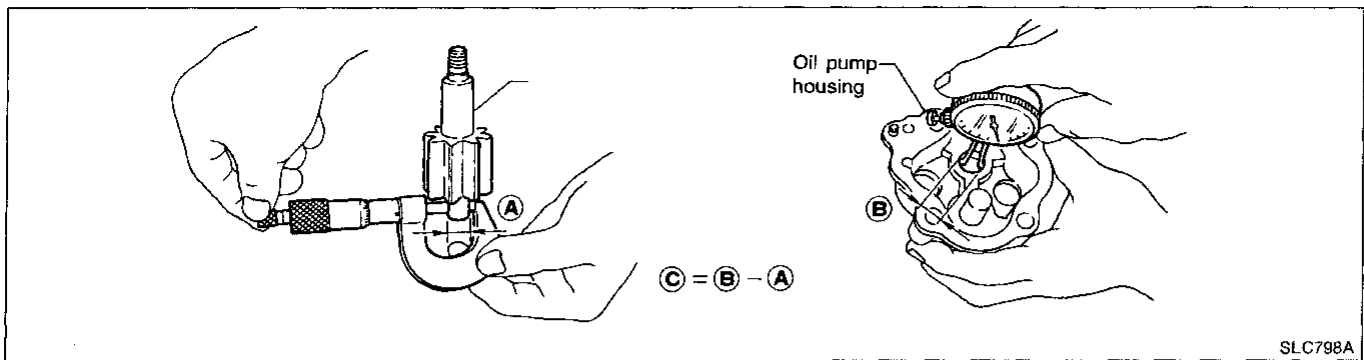

REGULATOR VALVE INSPECTION

1. Visually inspect components for wear and damage.
2. Check oil pressure regulator valve sliding surface and valve spring.
3. Coat regulator valve with engine oil and check that it falls smoothly into the valve hole by its own weight.
4. Check regulator valve to oil pump cover clearance.

Standard clearance:

L : 0.040 - 0.097 mm (0.0016 - 0.0038 in)

If damaged, replace regulator valve set or oil pump assembly.

ENGINE COOLING SYSTEM

Cooling Circuit

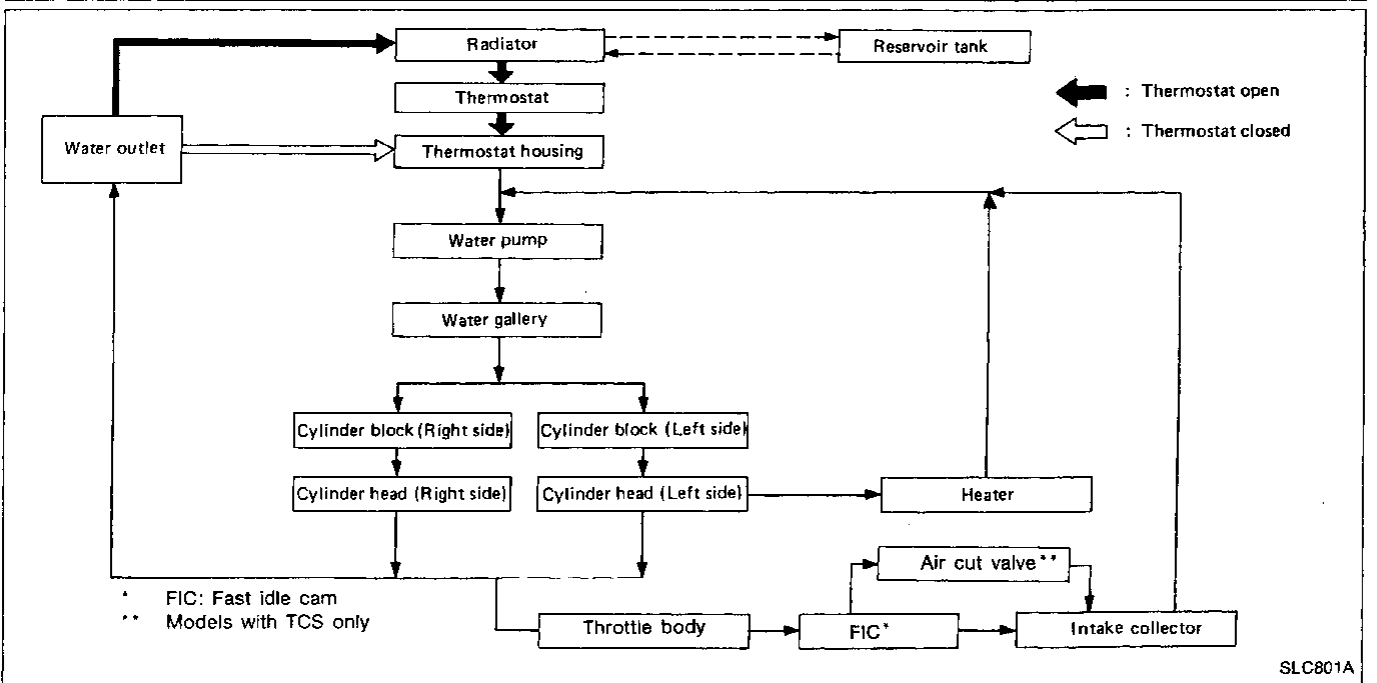
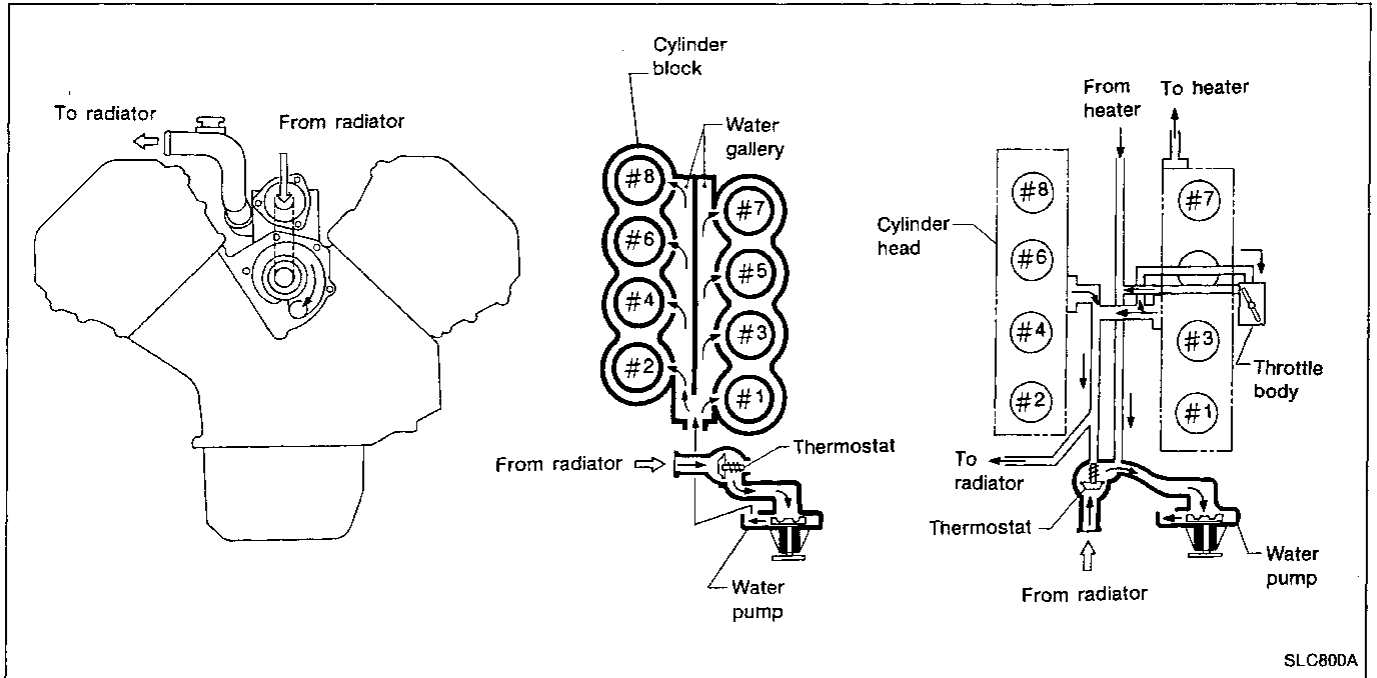

System Check

WARNING:

Never remove the filler cap nor radiator cap when the engine is hot; serious burns could be caused by hot high pressure fluid escaping from the radiator.

Wrap a thick cloth around cap and carefully remove the cap by first turning it a quarter turn to allow built-up pressure to escape and then turn the cap all the way off.

ENGINE COOLING SYSTEM

System Check (Cont'd)

CHECKING COOLING SYSTEM HOSES

Check hoses for improper attachment, leaks, cracks, damage, loose connections, chafing and deterioration.

CHECKING COOLING SYSTEM FOR LEAKS

To check for leakage, apply pressure to the cooling system with a tester.

Testing pressure:

157 kPa (1.6 kg/cm², 23 psi)

CAUTION:

Higher than the specified pressure may damage radiator.

CHECKING RADIATOR CAP

To check radiator cap, apply pressure to cap with a tester.

Radiator cap relief pressure:

78 - 98 kPa (0.8 - 1.0 kg/cm², 11 - 14 psi)

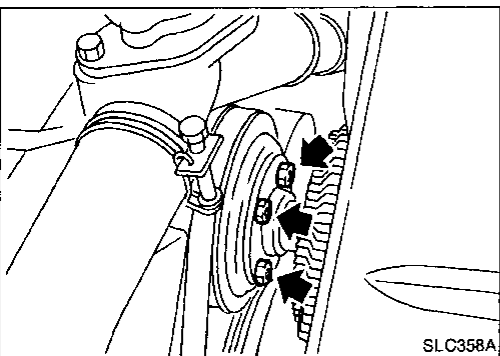
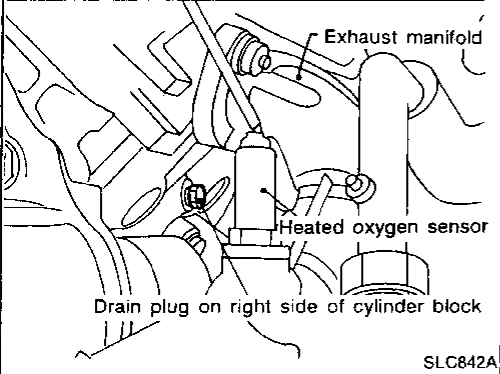
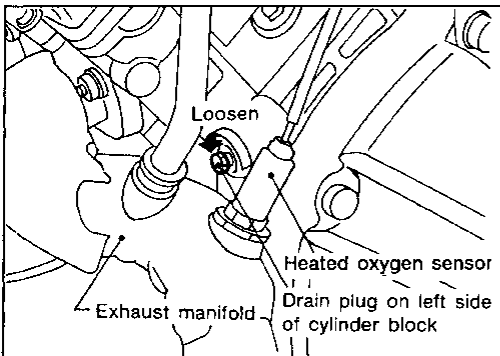
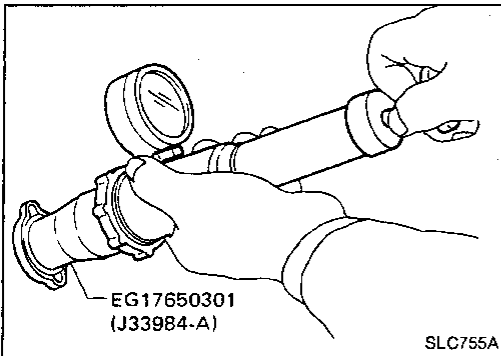
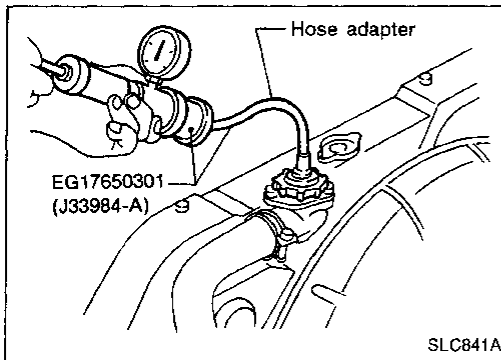

Water Pump

REMOVAL

1. Drain coolant from drain cocks on both sides of cylinder block and radiator.
2. Remove fan coupling with fan.
3. Loosen power steering pump drive belt.
4. Remove water pump.

ENGINE COOLING SYSTEM

Water Pump (Cont'd)

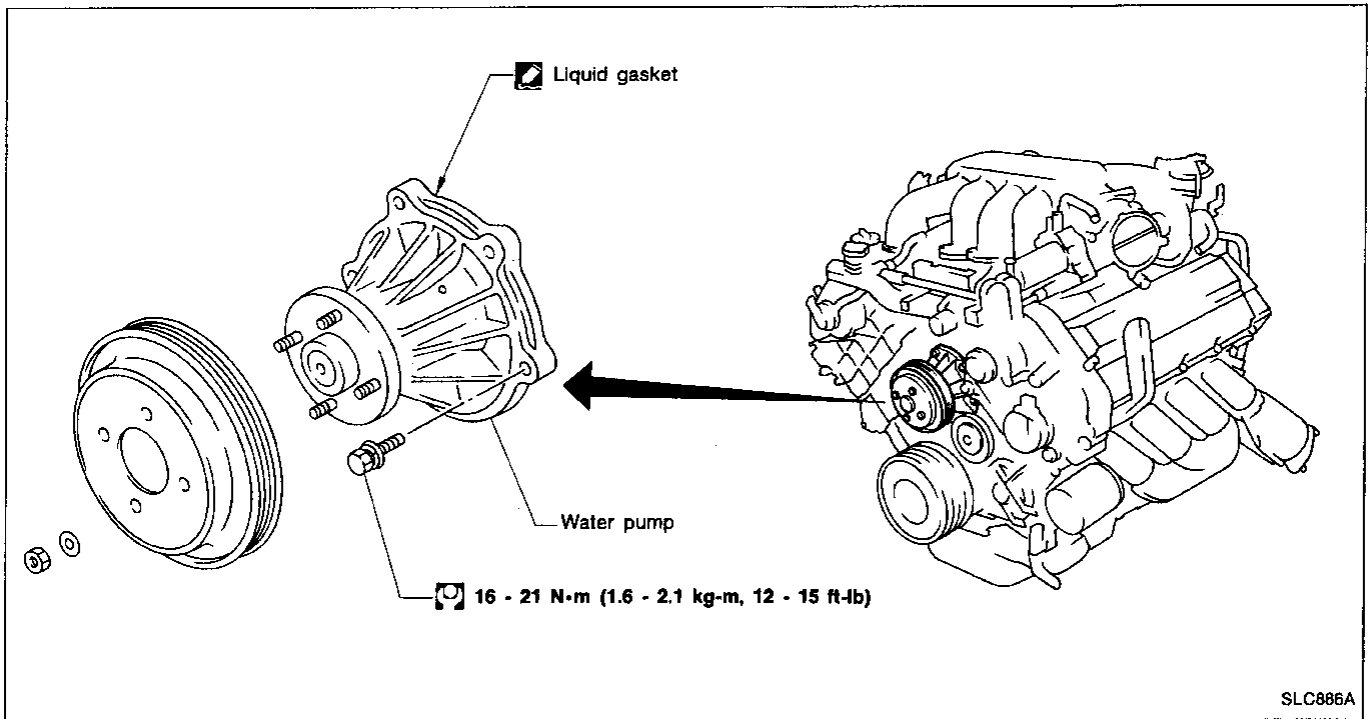

CAUTION:

- When removing water pump assembly, be careful not to get coolant on drive belt.
- Water pump cannot be disassembled and should be replaced as a unit.
- After installing water pump, connect hose and clamp securely, then check for leaks using radiator cap tester.

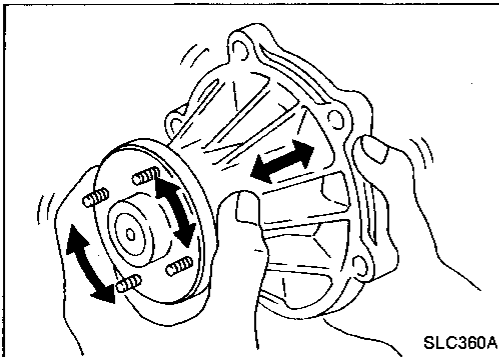

INSPECTION

1. Check for badly rusted or corroded vanes and body assembly.
2. Check for rough operation due to excessive end play.

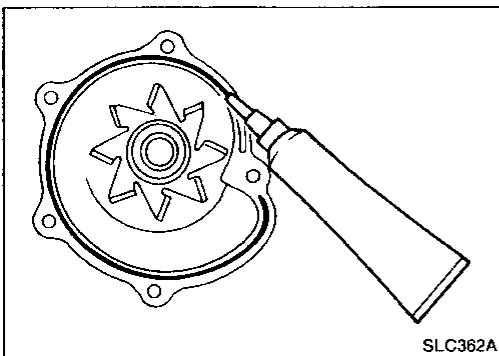

INSTALLATION

1. Before installing water pump, remove all traces of liquid gasket from mating surface using a scraper.
 - Also remove traces of liquid gasket from mating surface of cylinder block.
2. Apply a continuous bead of liquid gasket to mating surface of water pump.
 - Use Genuine Liquid Gasket or equivalent.

ENGINE COOLING SYSTEM

Thermostat

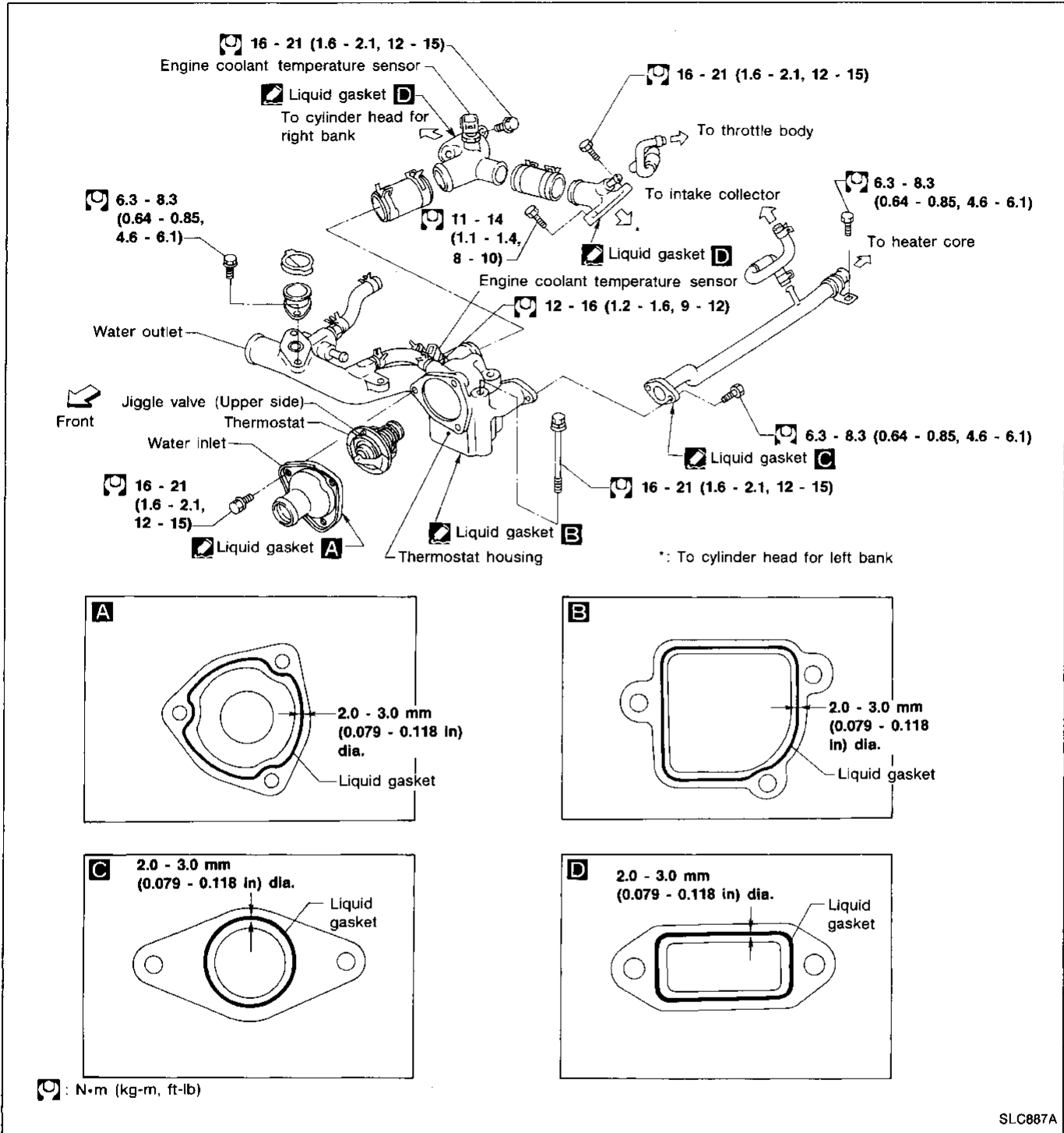

REMOVAL AND INSTALLATION

Removal

1. Drain coolant from drain cocks on both sides of cylinder block and radiator
2. Remove front ornament cover.
3. Remove water inlet and thermostat.

ENGINE COOLING SYSTEM

Thermostat (Cont'd)

Installation

- Remove liquid gasket from mating surface of each part using a scraper.
- Similarly, remove liquid gasket from mating surface.
- Clean all traces of liquid gasket using white gasoline.

GI

MA

EM

LC

EF &
EC

FE

AT

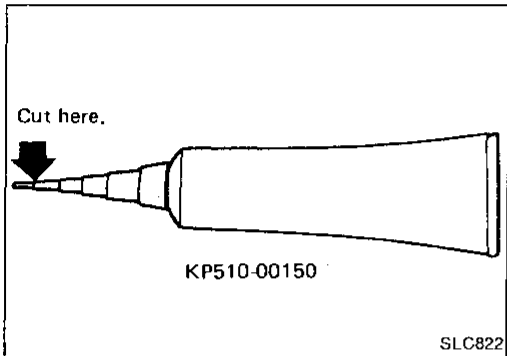
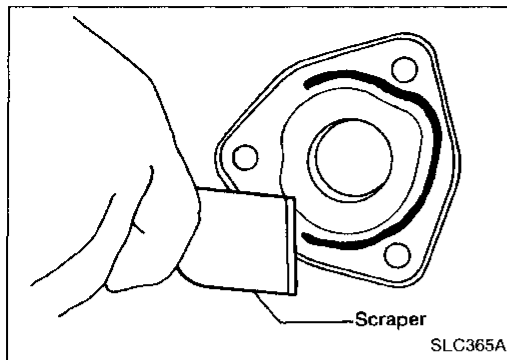

- Cut off tip of nozzle of liquid gasket tube at point shown in figure.
- Use Genuine Liquid Gasket or equivalent.

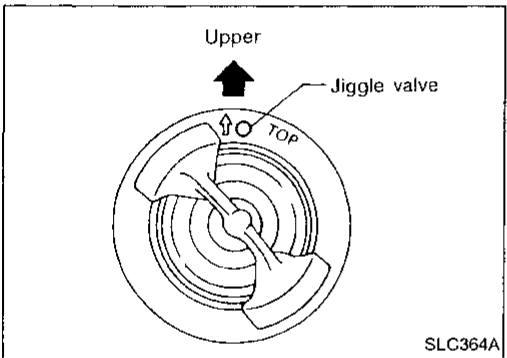

INSPECTION

1. Check for valve seating condition at ordinary temperatures. It should seat tightly.

PD

FA

RA

BR

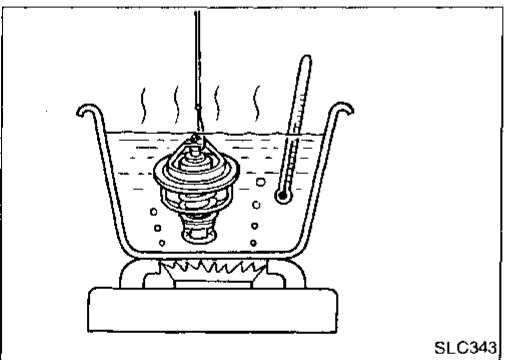

2. Check valve opening temperature and maximum valve lift.

Valve opening temperature	°C (°F)	76.5 (170)
Maximum valve lift	mm/°C (in/°F)	10/90 (0.39/194)

ST

BF

3. Then check if valve closes at 5°C (9°F) below valve opening temperature.

HA

- After installation, run engine for a few minutes, and check for leaks.
- Be careful not to spill coolant over engine compartment. Use a rag to absorb coolant.

EL

Radiator

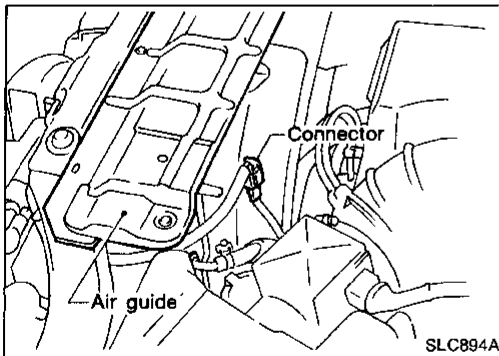
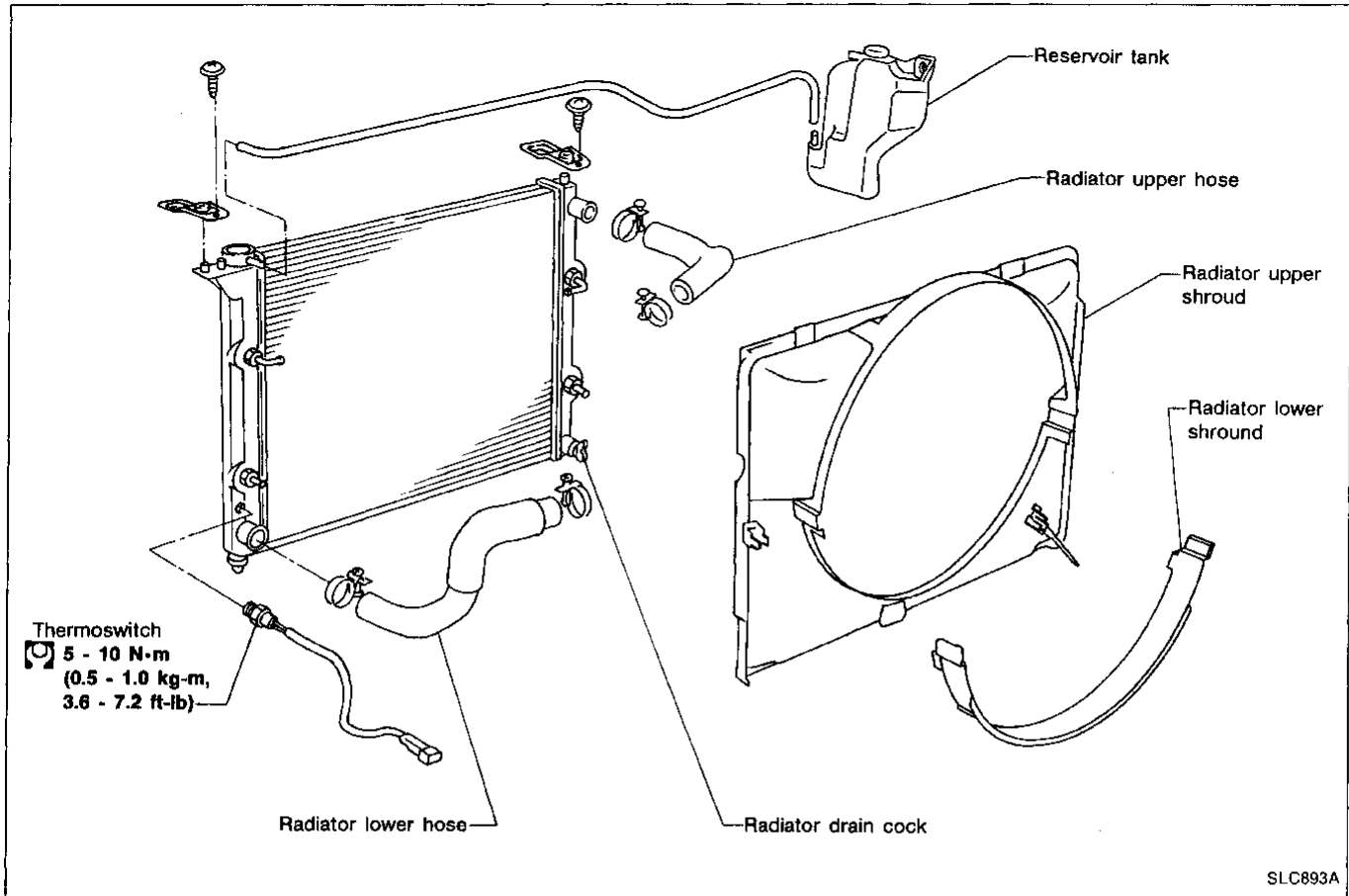

REMOVAL AND INSTALLATION

1. Remove air guide.
2. Detach connector from radiator upper shroud.
3. Remove radiator lower shroud.

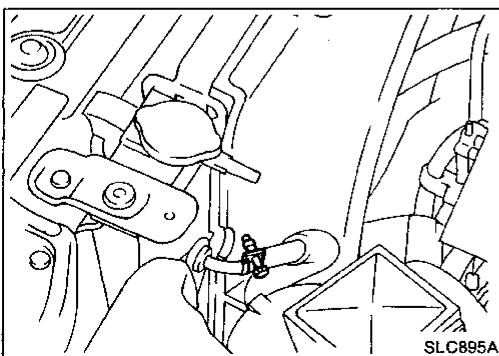

4. Loosen both A/T upper oil cooler hose clamps and turn the clamps to make room.
5. Remove filler cap above radiator upper hose.
6. Remove undercover.
7. Drain coolant from radiator drain cock.
8. Detach A/T oil cooler hoses from clip of shroud.

ENGINE COOLING SYSTEM

Radiator (Cont'd)

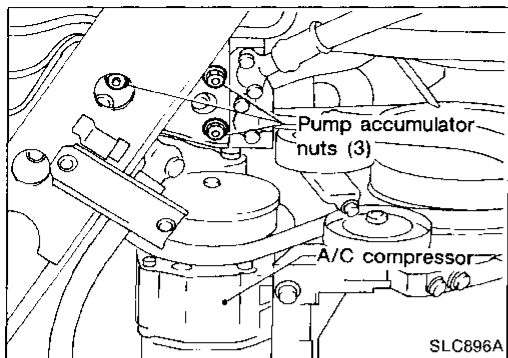

9. Remove pump accumulator nuts (3) and move the pump accumulator as shown on the left.
10. Loosen bolts of A/T oil cooler hose bracket and remove bracket from radiator shroud.
11. Remove upper shroud screws (4).
12. Remove upper shroud.
13. Disconnect A/T oil cooler hoses and radiator hoses.
14. Remove radiator mounting bracket.
15. Remove radiator.

GI

MA

EM

LC

EF &
EC

FE

AT

PD

FA

RA

BR

ST

BF

HA

EL

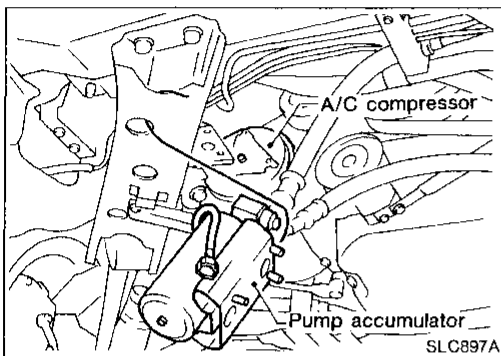

16. After repairing or replacing radiator, reinstall any part in reverse order of removal.

CAUTION:

- If A/T oil cooler hoses and radiator hoses are disconnected, A/T fluid level and engine coolant must be checked and refilled if necessary.
- Check level of A/T fluid. (Refer to "Checking A/T fluid" in MA section.)
- Check level of coolant. (Refer to "Checking Engine Coolant" in MA section.)

Cooling Fan (Crankshaft driven)

DISASSEMBLY AND ASSEMBLY

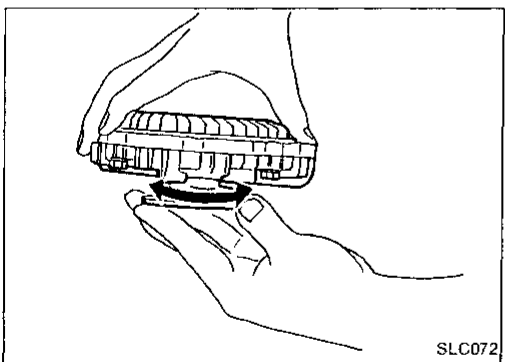
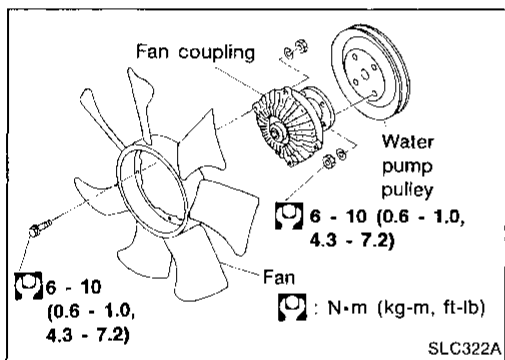

INSPECTION

Check fan coupling for rough operation, oil leakage or bent bimetal.

Cooling Fan (Motor driven)

This cooling fan is controlled by ECM (ECCS control module). Refer to "ENGINE AND EMISSION CONTROL SYSTEM DESCRIPTION" in EF & EC section.

SERVICE DATA AND SPECIFICATIONS (S.D.S.)

Engine Lubrication System

Oil pressure check

Engine speed rpm	Approximate discharge pressure kPa (kg/cm ² , psi)
Idle speed 3,000	More than 98 (1.0, 14) 461 - 559 (4.7 - 5.7, 67 - 81)

Oil pump

Unit: mm (in)

Drive shaft to oil pump cover and housing: ⑥	0.024 - 0.069 (0.0009 - 0.0027)
Driven gear to driven shaft: ⑦	0.025 - 0.064 (0.0010 - 0.0025)
Drive and driven gear to oil pump housing: ⑧	0.08 - 0.130 (0.0031 - 0.0051)
Drive and driven gear to oil pump housing: ⑨	0.125 - 0.245 (0.0049 - 0.0096)

Engine Cooling System

Thermostat

	Standard
Valve opening temperature °C (°F)	76.5 (170)
Maximum valve lift mm/°C (in/°F)	10/90 (0.39/194)

Radiator

Unit: kPa (kg/cm², psi)

Cap relief pressure	78 - 98 (0.8 - 1.0, 11 - 14)
Leakage test pressure	157 (1.6, 23)