

# AUTOMATIC TRANSMISSION

## SECTION **AT**

GI

MA

EM

LC

EF &  
EC

FE

**AT**

PD

FA

RA

BR

ST

RS

BT

HA

EL

IDX

## CONTENTS

<b>PREPARATION AND PRECAUTIONS</b> .....	2	Installation .....	111
Special Service Tools .....	2	<b>MAJOR OVERHAUL</b> .....	112
Precautions .....	3	Oil Channel .....	114
Supplemental Restraint System (SRS) "AIR BAG" and "SEAT BELT PRE-TENSIONER" .....	4	Locations of Needle Bearings, Thrust Washers and Snap Rings .....	115
<b>DESCRIPTION</b> .....	5	<b>DISASSEMBLY</b> .....	116
Cross-sectional View .....	5	<b>REPAIR FOR COMPONENT PARTS</b> .....	128
Hydraulic Control Circuits .....	6	Oil Pump .....	128
Shift Mechanism .....	7	Control Valve Assembly .....	132
Control System .....	9	Control Valve Upper Body .....	138
<b>TROUBLE DIAGNOSES</b> .....	11	Control Valve Lower Body .....	144
Contents .....	11	Reverse Clutch .....	146
A/T Electrical Parts Location .....	34	High Clutch .....	150
<b>TROUBLE DIAGNOSES — A/T Shift Lock System</b> .....	91	Forward and Overrun Clutches .....	152
Contents .....	91	Low & Reverse Brake .....	156
<b>ON-VEHICLE SERVICE</b> .....	106	Forward Clutch Drum Assembly .....	160
Control Valve Assembly and Accumulators		Rear Internal Gear and Forward Clutch Hub .....	162
Inspection .....	106	Band Servo Piston Assembly .....	164
Kickdown Switch Adjustment .....	106	Parking Pawl Components .....	168
Revolution Sensor Replacement .....	107	<b>ASSEMBLY</b> .....	170
Rear Oil Seal Replacement .....	107	Assembly (1) .....	170
Parking Components Inspection .....	107	Adjustment .....	175
Inhibitor Switch Adjustment .....	108	Assembly (2) .....	179
Manual Control Linkage Adjustment .....	108	<b>SERVICE DATA AND SPECIFICATIONS (SDS)</b> .....	189
<b>REMOVAL AND INSTALLATION</b> .....	109	General Specifications .....	189
Removal .....	109	Specifications and Adjustment .....	189

### When you read wiring diagrams:

- Read GI section, "HOW TO READ WIRING DIAGRAMS".
- See EL section, "POWER SUPPLY ROUTING" for power distribution circuit.

When you perform trouble diagnoses, read GI section, "HOW TO FOLLOW FLOW CHART IN TROUBLE DIAGNOSES".

# PREPARATION AND PRECAUTIONS

## Special Service Tools

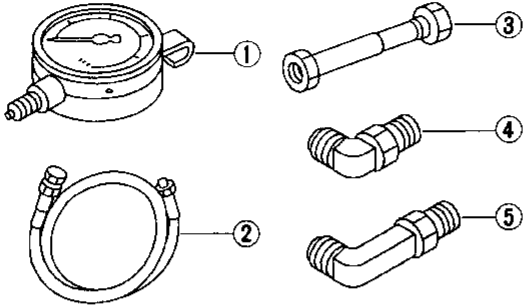
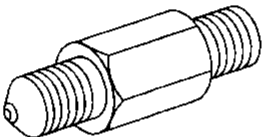
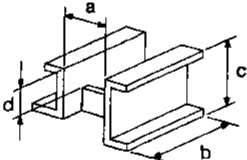
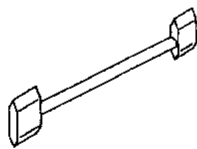
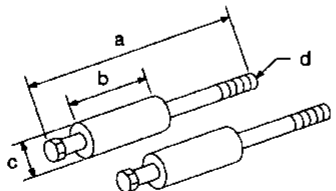
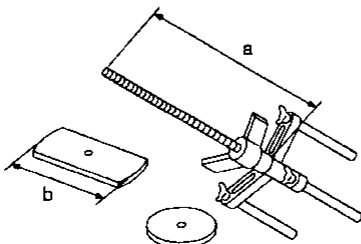
Tool number (Kent-Moore No.) Tool name	Description
ST2505S001 (J25695-A) Oil pressure gauge set ① ST25051001 ( — ) Oil pressure gauge ② ST25052000 ( — ) Hose ③ ST25053000 ( — ) Joint pipe ④ ST25054000 ( — ) Adapter ⑤ ST25055000 ( — ) Adapter	Measuring line pressure  <p style="text-align: center;">NT097</p>
KV31101201 ( — ) Oil pressure gauge adapter	Measuring line pressure  <p style="text-align: center;">NT093</p>
ST07870000 (J37068) Transmission case stand	Disassembling and assembling A/T a: 182 mm (7.17 in) b: 282 mm (11.10 in) c: 230 mm (9.06 in) d: 100 mm (3.94 in)  <p style="text-align: center;">NT421</p>
KV31102100 (J37065) Torque converter one- way clutch check tool	Checking one-way clutch in torque converter  <p style="text-align: center;">NT098</p>
ST25850000 (J25721-A) Sliding hammer	Removing oil pump assembly a: 179 mm (7.05 in) b: 70 mm (2.76 in) c: 40 mm (1.57 in) dia. d: M12 x 1.75P  <p style="text-align: center;">NT422</p>
KV31102400 (J34285 and J34285-87) Clutch spring compressor	Removing and installing clutch return springs a: 320 mm (12.60 in) b: 174 mm (6.85 in)  <p style="text-align: center;">NT423</p>

# PREPARATION AND PRECAUTIONS

## Special Service Tools (Cont'd)

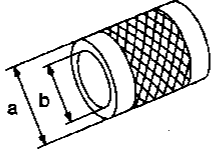
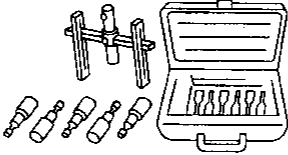
Tool number (Kent-Moore No.) Tool name	Description
ST33200000 (J26082) Drift	 <p>Installing oil pump housing oil seal Installing rear oil seal</p> <p><b>a: 60 mm (2.36 in) dia.</b> <b>b : 44.5 mm (1.752 in) dia.</b></p> <p>NT091</p>
(J34291) Shim setting gauge set	 <p>Selecting oil pump cover bearing race and oil pump thrust washer</p> <p>NT101</p>

### Precautions

- Before proceeding with disassembly, thoroughly clean the outside of the transmission. It is important to prevent the internal parts from becoming contaminated by dirt or other foreign matter.
- Disassembly should be done in a clean work area.
- Use lint-free cloth or towels for wiping parts clean. Common shop rags can leave fibers that could interfere with the operation of the transmission.
- Place disassembled parts in order, on a parts rack, for easier and proper assembly.
- All parts should be carefully cleaned with a general purpose, non-flammable solvent before inspection or reassembly.
- Gaskets, seals and O-rings should be replaced any time the transmission is disassembled.
- It is very important to perform functional tests whenever they are indicated.

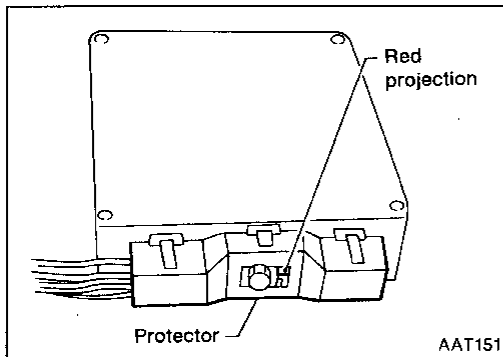

- When connecting A/T control unit harness connector, tighten bolt until red projection is in-line with connector.
- The valve body contains precision parts and requires extreme care when parts are removed and serviced. Place disassembled valve body parts in order, on a parts rack, for easier and proper assembly. Care will also prevent springs and small parts from becoming scattered or lost.
- Properly installed valves, sleeves, plugs, etc. will slide along their bores in the valve body under their own weight.
- Before assembly, apply a coat of recommended ATF to all parts. Apply petroleum jelly to protect O-ring and seals, or hold bearings and washers in place during assembly. Do not use grease.
- Extreme care should be taken to avoid damage to O-rings, seals and gaskets when assembling.
- After overhaul, refill the transmission with new ATF.

### **Supplemental Restraint System (SRS) “AIR BAG” and “SEAT BELT PRE-TENSIONER”**

The Supplemental Restraint System “Air Bag” and “Seat Belt Pre-tensioner”, used along with a seat belt, help to reduce the risk or severity of injury to the driver and front passenger in a frontal collision. The Supplemental Restraint System consists of air bag modules (located in the center of the steering wheel and on the instrument panel on the passenger side), seat belt pre-tensioners, a diagnosis sensor unit, warning lamp, wiring harness and spiral cable. Information necessary to service the system safely is included in the **RS section** of this Service Manual.

#### **WARNING:**

- **To avoid rendering the SRS inoperative, which could increase the risk of personal injury or death in the event of a collision which would result in air bag inflation, all maintenance must be performed by an authorized INFINITI dealer.**
- **Improper maintenance, including incorrect removal and installation of the SRS, can lead to personal injury caused by unintentional activation of the system.**
- **All SRS air bag electrical wiring harnesses and connectors are covered with yellow outer insulation. Do not use electrical test equipment on any circuit related to the SRS.**

# DESCRIPTION

## Cross-sectional View

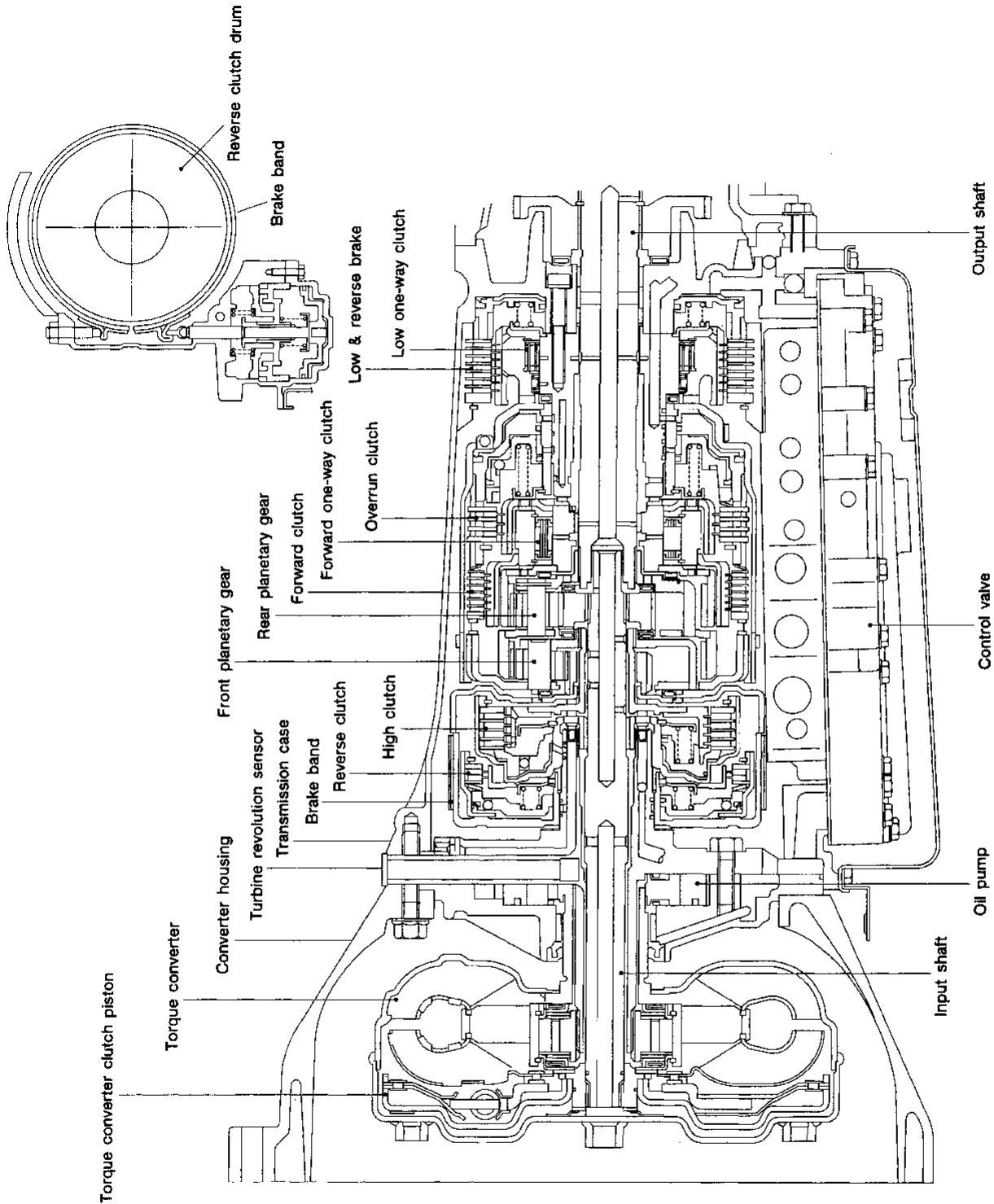

GI  
MA  
EM  
LC  
EF &  
EC  
FE  
**AT**  
PD  
FA  
RA  
BR  
ST  
RS  
BT  
HA  
EL  
IDX

# DESCRIPTION

## Hydraulic Control Circuits

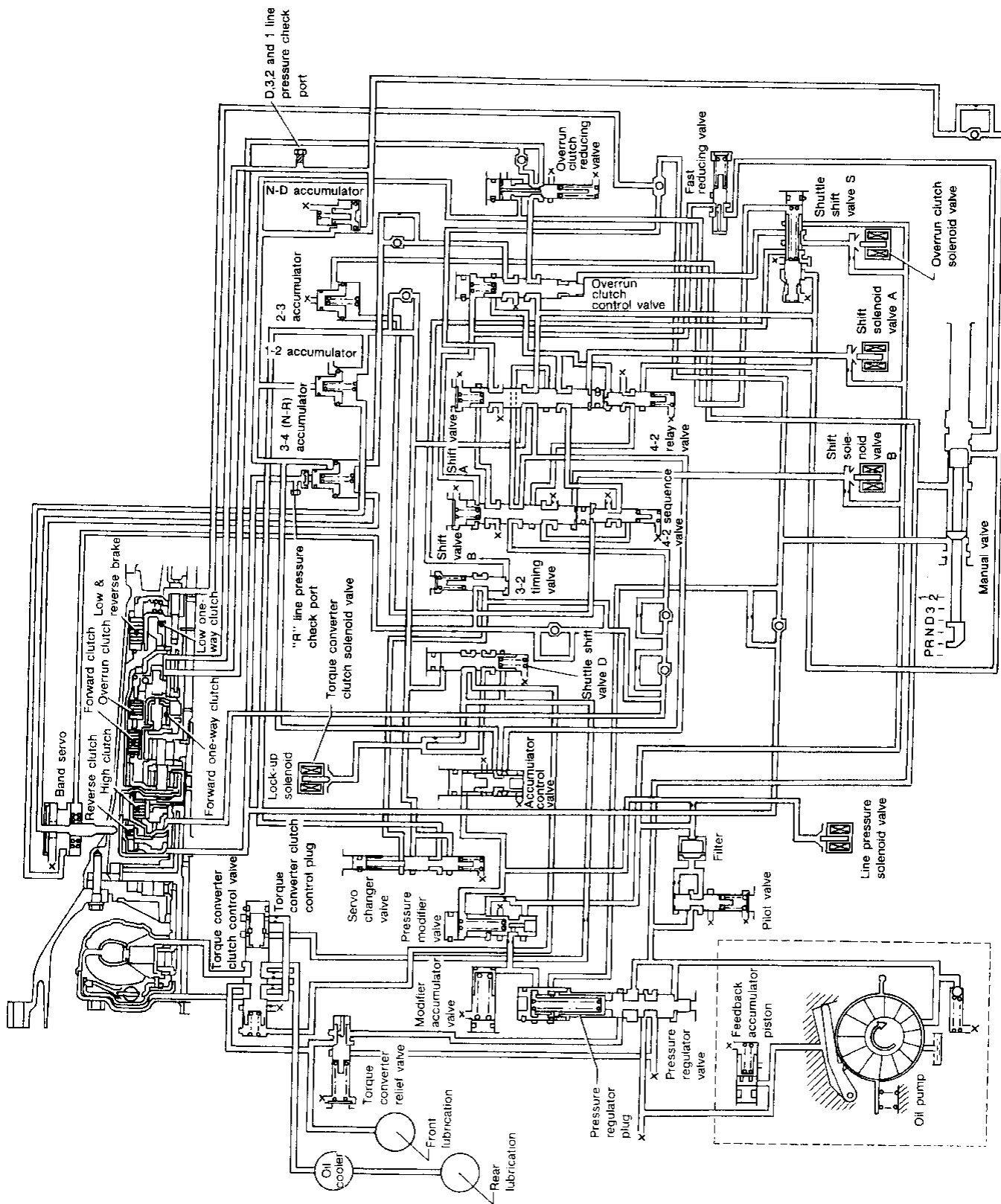

SAT007H

# DESCRIPTION

## Shift Mechanism

The RE4R03A automatic transmission uses compact, dual planetary gear systems to improve power-transmission efficiency, simplify construction and reduce weight.

It also employs an optimum shift control and superwide gear ratios. They improve starting performance and acceleration during medium and high-speed operation.

Two one-way clutches are also employed: one is used for the forward clutch and the other for the low clutch. These one-way clutches, combined with four accumulators, reduce shifting shock to a minimum.

## CONSTRUCTION

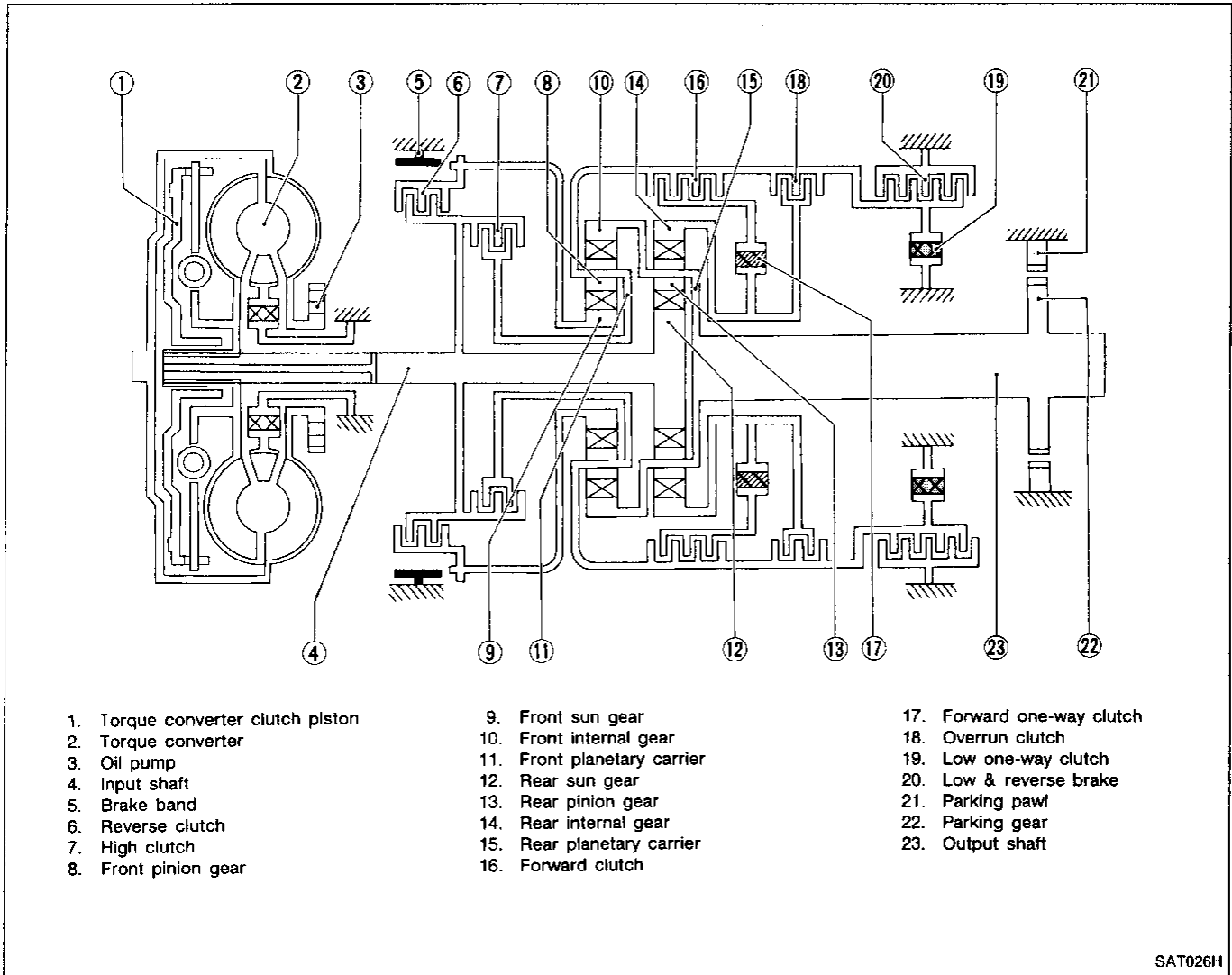

GI  
MA  
EM  
LC  
EF &  
EC  
FE  
AT  
PD  
FA  
RA  
BR  
ST  
RS  
BT  
HA  
EL  
IDX

## DESCRIPTION

### Shift Mechanism (Cont'd)

#### FUNCTION OF CLUTCH AND BRAKE

Control members	Abbr.	Function
Reverse clutch	R/C	To transmit input power to front sun gear
High clutch	H/C	To transmit input power to front planetary carrier
Forward clutch	F/C	To connect front planetary carrier with forward one-way clutch
Overrun clutch	O/C	To connect front planetary carrier with rear internal gear
Brake band	B/B	To lock front sun gear
Forward one-way clutch	F/O.C	When forward clutch is engaged, to stop rear internal gear from rotating in opposite direction.
Low one-way clutch	L/O.C	At D <sub>1</sub> position, to prevent rear internal gear from rotating in opposite direction.
Low & reverse brake	L & R/B	To lock rear internal gear (2, 1 <sub>2</sub> and 1 <sub>1</sub> ), to lock front planetary carrier (R position)

#### OPERATION OF CLUTCH AND BRAKE

Shift position	R/C	H/C	F/C	O/C	Band servo			F/O.C	L/O.C	L & R/B	Remarks
					Applies in 2nd speed	Releases in 3rd speed	Applies in 4th speed				
P											PARK
R	○									○	REVERSE
N											NEUTRAL
D	1st		○					●	●		Automatic shift 1 ↔ 2 ↔ 3 ↔ 4
	2nd		○		○			●			
	3rd		○	○		*1 ⊗	⊗	●			
	4th		○	⊗		*2 ⊗	⊗	○			
3	1st		○	⊗				●	●		Automatic shift 1 ↔ 2 ↔ 3 ← 4
	2nd		○	⊗	○			●			
	3rd		○	○	⊗	*1 ⊗	⊗	●			
2	1st		○	○				●		○	Locks in 2nd speed 1 ↔ 2 ← 3
	2nd		○	○				●			
1	1st		○	○				●		○	Locks in 1st speed 1 ← 2
	2nd		○	○	○			●			

**Notes:**

\*1. Oil pressure is applied to both 2nd "apply" side and 3rd "release" side of band servo piston. However, because oil pressure area on the "release" side is greater than that on the "apply" side, brake band does not contract.

\*2. Oil pressure is applied to 4th "apply" side in condition \*2 above, and brake band contracts.

- : Operates
- ⊗ : Operates when throttle opening is less than 1/16. Engine brake activates.
- : Operates during "progressive" acceleration
- ⊗ : Operates but does not affect power transmission
- ⊗ : Operates when throttle opening is less than 1/16 but does not affect engine brake



# DESCRIPTION

## Control System

### OUTLINE

The RE4R03A automatic transmission senses vehicle operating conditions through various sensors. It always controls the optimum shift position and reduces shifting and lock-up shocks.

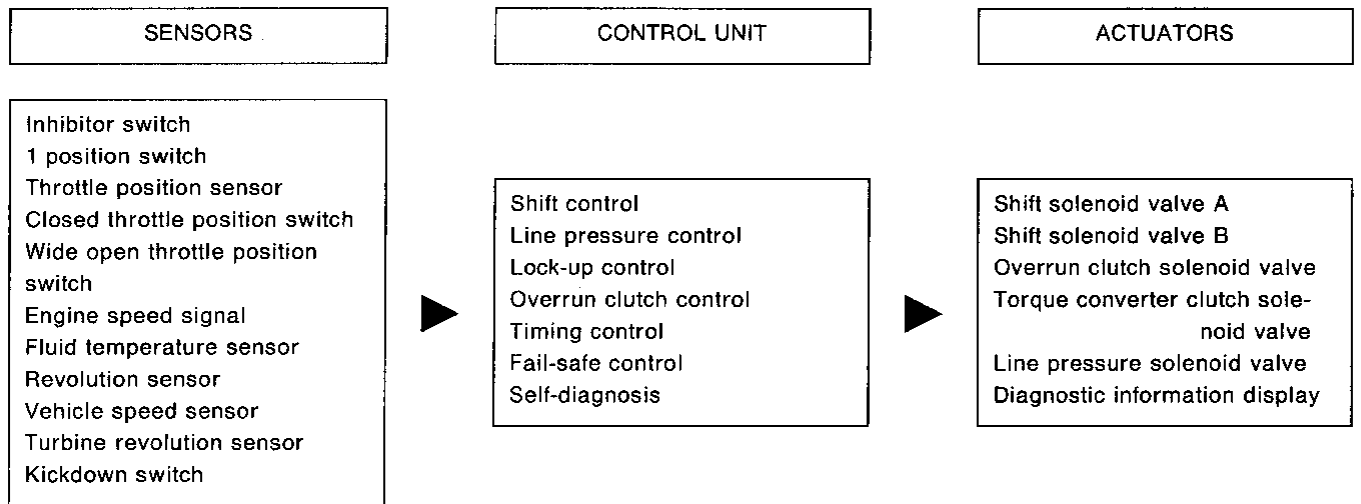

GI  
MA  
EM  
LC  
EF & EC  
FE  
AT

### CONTROL SYSTEM

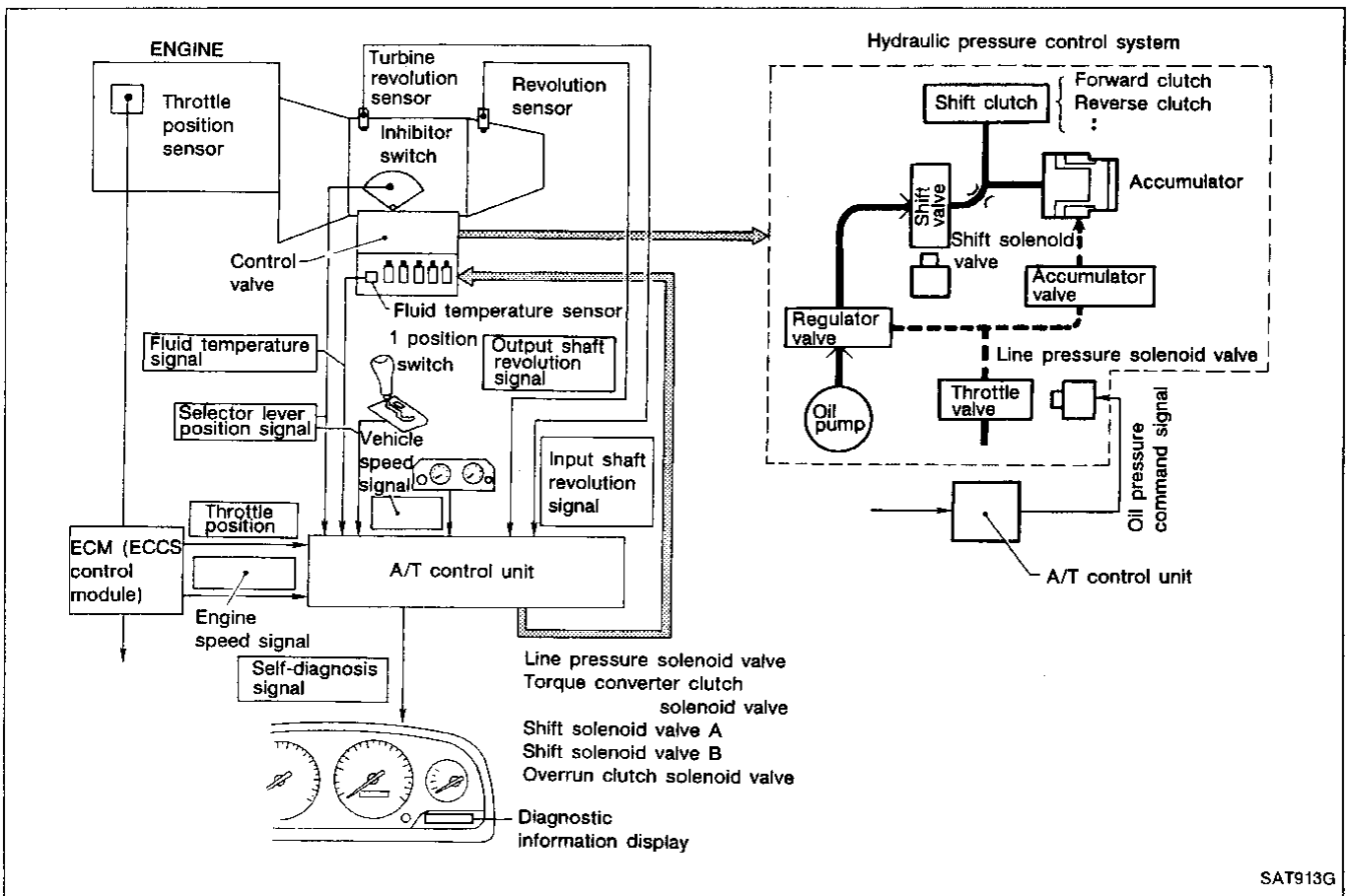

PD  
FA  
RA  
BR  
ST  
RS  
BT  
HA  
EL  
IDX

SAT913G

## DESCRIPTION

### Control System (Cont'd)

#### A/T CONTROL UNIT FUNCTION

The function of the A/T control unit is to:

- Receive input signals sent from various switches and sensors.
- Determine required line pressure, shifting point, lock-up operation, and engine brake operation.
- Send required output signals to the respective solenoids.

#### INPUT/OUTPUT SIGNAL OF A/T CONTROL UNIT

	Sensors and solenoid valves	Function
Input	Inhibitor switch	Detects select lever position and sends a signal to A/T control unit.
	"1" position switch	Sends a signal to A/T control unit when select lever is set to "1".
	Throttle position sensor	Detects throttle valve position and sends a signal to A/T control unit.
	Closed throttle position switch	Detects throttle valve's fully-closed position and sends a signal to A/T control unit.
	Wide open throttle position switch	Detects throttle valve position of greater than 1/2 of full throttle and sends a signal to A/T control unit. A/T control unit uses the signal only when throttle sensor malfunctions.
	Engine speed signal	From ECM (ECCS control module).
	Fluid temperature sensor	Detects transmission fluid temperature and sends a signal to A/T control unit.
	Revolution sensor	Detects output shaft rpm and sends a signal to A/T control unit.
	Vehicle speed sensor	Used as an auxiliary vehicle speed sensor. Sends a signal when revolution sensor (installed on transmission) malfunction.
	Turbine revolution sensor	Sends an input shaft revolution signal.
Output	Kickdown switch	Detects full throttle position (accelerator pedal fully depressed). Sends a signal to A/T control unit when throttle position sensor malfunctions.
	Shift solenoid valve A/B	Selects shifting point suited to driving conditions in relation to a signal sent from A/T control unit.
	Line pressure solenoid valve	Regulates (or decreases) line pressure in relation to a signal sent from A/T control unit.
	Torque converter clutch solenoid valve	Regulates (or decreases) lock-up pressure in relation to a signal sent from A/T control unit.
	Overrun clutch solenoid valve	Controls an "engine brake" effect in relation to a signal sent from A/T control unit.
	Diagnostic information display	Shows A/T control unit faults, when A/T control components malfunction.

# TROUBLE DIAGNOSES

## Contents

<b>How to Perform Trouble Diagnoses for Quick and Accurate Repair</b> .....	AT-13	
<b>Fail-Safe Remarks</b> .....	AT-17	
<b>Diagnosis by CONSULT</b> .....	AT-18	GI
<b>Preliminary Check</b> .....	AT-21	
<b>A/T Electrical Parts Location</b> .....	AT-34	
<b>Circuit Diagram for Quick Pinpoint Check</b> .....	AT-36	MA
<b>Wiring Diagram</b> .....	AT-38	
<b>Self-diagnosis</b> .....	AT-40	EM
SELF-DIAGNOSTIC PROCEDURE (With CONSULT) .....	AT-40	
SELF-DIAGNOSTIC PROCEDURE (Without CONSULT) .....	AT-41	
JUDGEMENT OF SELF-DIAGNOSIS CODE .....	AT-42	LC
REVOLUTION SENSOR CIRCUIT CHECK .....	AT-44	
VEHICLE SPEED SENSOR CIRCUIT CHECK .....	AT-45	EF & EC
THROTTLE POSITION SENSOR CIRCUIT CHECK .....	AT-46	
SHIFT SOLENOID VALVE A CIRCUIT CHECK .....	AT-47	
SHIFT SOLENOID VALVE B CIRCUIT CHECK .....	AT-48	FE
OVERRUN CLUTCH SOLENOID VALVE CIRCUIT CHECK .....	AT-49	
TORQUE CONVERTER CLUTCH SOLENOID VALVE CIRCUIT CHECK .....	AT-50	
FLUID TEMPERATURE SENSOR CIRCUIT AND A/T CONTROL UNIT POWER SOURCE CIRCUIT CHECKS .....	AT-51	AT
ENGINE SPEED SIGNAL CIRCUIT CHECK .....	AT-52	
TURBINE REVOLUTION SENSOR CIRCUIT CHECK .....	AT-53	PD
LINE PRESSURE SOLENOID VALVE CIRCUIT CHECK .....	AT-54	
ENGINE CONTROL CIRCUIT CHECK .....	AT-55	FA
INHIBITOR SWITCH, 1 POSITION SWITCH, KICKDOWN SWITCH, CLOSED THROTTLE POSITION SWITCH AND DIAGNOSTIC INFORMATION DISPLAY CIRCUIT CHECKS .....	AT-56	
<b>Diagnostic Procedure 1</b> .....		RA
(SYMPTOM: Engine cannot be started with selector lever in "P" or "N" position. Engine can be started with selector lever in "D", "3", "2", "1", or "R" position.) .....	AT-59	
<b>Diagnostic Procedure 2</b> .....		BR
(SYMPTOM: Vehicle moves when it is pushed forward or backward with selector lever in "P" position.) .....	AT-59	
<b>Diagnostic Procedure 3</b> .....		ST
(SYMPTOM: Vehicle moves forward or backward when selecting "N" position.) .....	AT-60	
<b>Diagnostic Procedure 4</b> .....		RS
(SYMPTOM: There is large shock when changing from "N" to "R" position.) .....	AT-61	
<b>Diagnostic Procedure 5</b> .....		BT
(SYMPTOM: Vehicle does not creep backward when selecting "R" position.) .....	AT-62	
<b>Diagnostic Procedure 6</b> .....		HA
(SYMPTOM: Vehicle does not creep forward when selecting "D", "3", "2" or "1" position.) .....	AT-63	
<b>Diagnostic Procedure 7</b> .....		EL
(SYMPTOM: Vehicle cannot be started from D <sub>1</sub> on Cruise test — Part 1.) .....	AT-64	
<b>Diagnostic Procedure 8</b> .....		IDX
(SYMPTOM: A/T does not shift from D <sub>1</sub> to D <sub>2</sub> at the specified speed. A/T does not shift from D <sub>4</sub> to D <sub>2</sub> when depressing accelerator pedal fully at the specified speed.) .....	AT-65	
<b>Diagnostic Procedure 9</b> .....		
(SYMPTOM: A/T does not shift from D <sub>2</sub> to D <sub>3</sub> at the specified speed.) .....	AT-66	
<b>Diagnostic Procedure 10</b> .....		
(SYMPTOM: A/T does not shift from D <sub>3</sub> to D <sub>4</sub> at the specified speed.) .....	AT-67	

# TROUBLE DIAGNOSES

## Contents (Cont'd)

<b>Diagnostic Procedure 11</b> (SYMPTOM: A/T does not perform lock-up at the specified speed.) .....	AT-68
<b>Diagnostic Procedure 12</b> (SYMPTOM: A/T does not hold lock-up condition for more than 30 seconds.) .....	AT-69
<b>Diagnostic Procedure 13</b> (SYMPTOM: Lock-up is not released when accelerator pedal is released.) .....	AT-69
<b>Diagnostic Procedure 14</b> (SYMPTOM: With accelerator pedal released: ● Engine does not smoothly return to idle when A/T shifts from D <sub>4</sub> to D <sub>3</sub> . ● Vehicle does not decelerate by engine brake when changing selector lever from "D" to "3" position. ● Vehicle does not decelerate by engine brake when changing selector lever from "3" to "2" position.) .....	AT-70
<b>Diagnostic Procedure 15</b> (SYMPTOM: Vehicle does not start from D <sub>1</sub> on Cruise test — Part 2.) .....	AT-71
<b>Diagnostic Procedure 16</b> (SYMPTOM: A/T does not shift from D <sub>4</sub> to D <sub>2</sub> when depressing accelerator pedal fully at the specified speed.) .....	AT-72
<b>Diagnostic Procedure 17</b> (SYMPTOM: A/T does not shift from D <sub>2</sub> to D <sub>1</sub> when depressing accelerator pedal fully at the specified speed.) .....	AT-73
<b>Diagnostic Procedure 18</b> (SYMPTOM: A/T does not shift from D <sub>4</sub> to 3 <sub>3</sub> when changing selector lever from "D" to "3" position.) .....	AT-74
<b>Diagnostic Procedure 19</b> (SYMPTOM: A/T does not shift from 3 <sub>3</sub> to 2 <sub>2</sub> when changing selector lever from "3" to "2" position.) .....	AT-74
<b>Diagnostic Procedure 20</b> (SYMPTOM: A/T does not shift from 2 <sub>2</sub> to 1 <sub>1</sub> when changing selector lever from "2" to "1" position.) .....	AT-75
<b>Diagnostic Procedure 21</b> (SYMPTOM: Vehicle does not decelerate by engine brake when shifting from 2 <sub>2</sub> (1 <sub>2</sub> ) to 1 <sub>1</sub> .) .....	AT-75
<b>Electrical Components Inspection</b> .....	AT-75
<b>Final Check</b> .....	AT-84
<b>Symptom Chart</b> .....	AT-88

# TROUBLE DIAGNOSES

## How to Perform Trouble Diagnoses for Quick and Accurate Repair

A good understanding of the malfunctioning conditions can make troubleshooting faster and more accurate.

In general, the feeling about a problem depends on each customer. It is important to fully understand the symptoms or under what conditions a customer complains.

Make good use of the two sheets provided, "Information from customer" and "Diagnostic worksheet", in order to perform the best troubleshooting possible.

### WORK FLOW

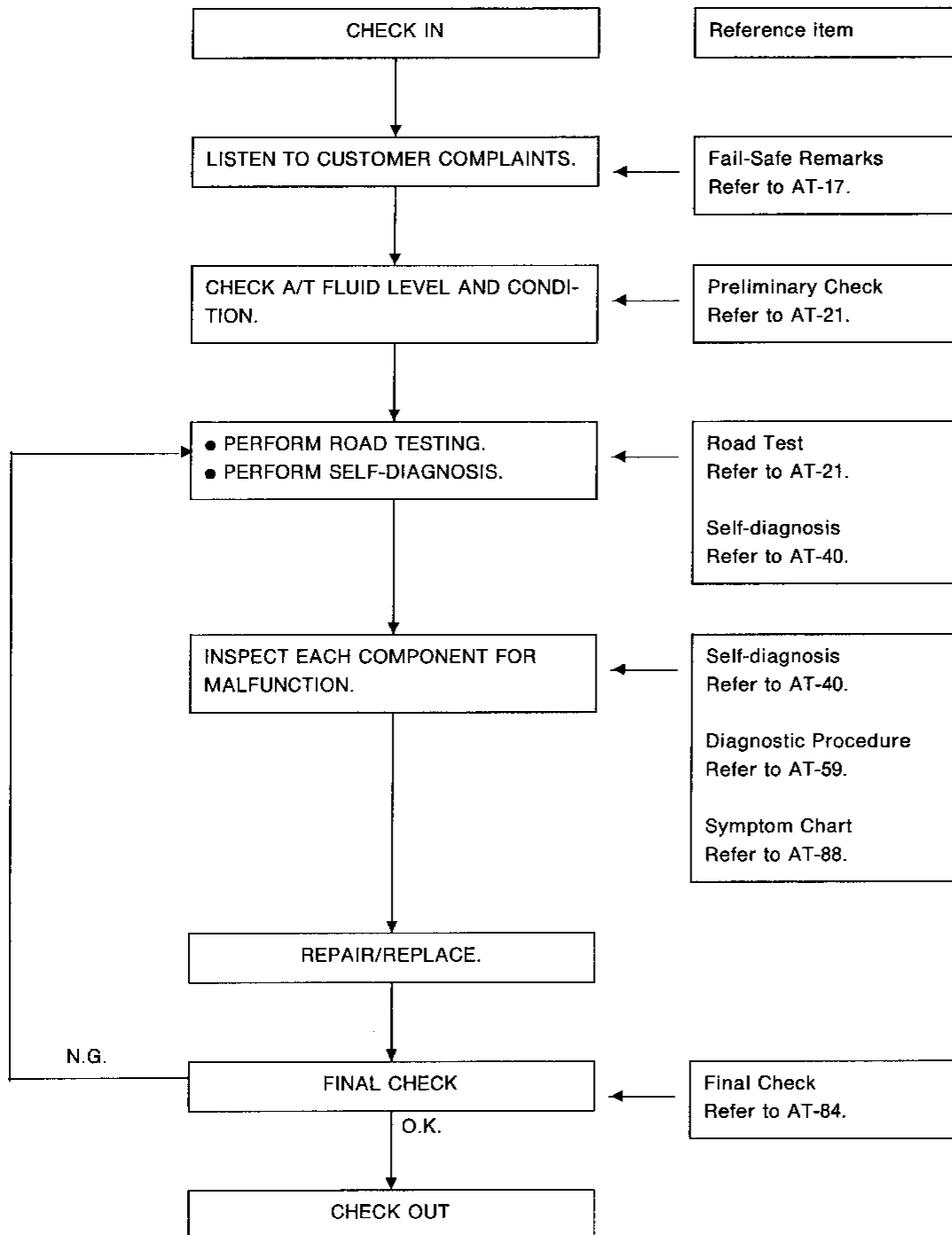

## TROUBLE DIAGNOSES

### How to Perform Trouble Diagnoses for Quick and Accurate Repair (Cont'd)

#### INFORMATION FROM CUSTOMER

##### KEY POINTS

**WHAT** ..... Vehicle & A/T model

**WHEN** ..... Date, Frequencies

**WHERE** ..... Road conditions

**HOW** ..... Operating conditions, Symptoms

Customer name MR/MS	Model & Year	VIN
Trans. model RE4R03A	Engine VH45DE	Mileage
Incident Date	Manuf. Date	In Service Date
Frequency	<input type="checkbox"/> Continuous <input type="checkbox"/> Intermittent ( times a day)	
Symptoms	<input type="checkbox"/> Vehicle does not move. ( <input type="checkbox"/> Any position <input type="checkbox"/> Particular position)	
	<input type="checkbox"/> No up-shift ( <input type="checkbox"/> 1st → 2nd <input type="checkbox"/> 2nd → 3rd <input type="checkbox"/> 3rd → O/D)	
	<input type="checkbox"/> No down-shift ( <input type="checkbox"/> O/D → 3rd <input type="checkbox"/> 3rd → 2nd <input type="checkbox"/> 2nd → 1st)	
	<input type="checkbox"/> Lockup malfunction	
	<input type="checkbox"/> Shift point too high or too low.	
	<input type="checkbox"/> Shift shock or slip ( <input type="checkbox"/> N → D <input type="checkbox"/> Lockup <input type="checkbox"/> Any drive position)	
	<input type="checkbox"/> Noise or vibration	
	<input type="checkbox"/> No kickdown	
	<input type="checkbox"/> No pattern select	
	<input type="checkbox"/> Others ( )	
Diagnostic information display	"TRANSMISSION MALFUNCTION"	
	<input type="checkbox"/> Come on	<input type="checkbox"/> Come off

# TROUBLE DIAGNOSES

## How to Perform Trouble Diagnoses for Quick and Accurate Repair (Cont'd)

### DIAGNOSTIC WORKSHEET

1.	<input type="checkbox"/> Read the Fail-safe Remarks and listen to customer complaints.	AT-17		
2.	<input type="checkbox"/> CHECK A/T FLUID <input type="checkbox"/> Leakage (Follow specified procedure) <input type="checkbox"/> Fluid condition <input type="checkbox"/> Fluid level	AT-21		
3.	<input type="checkbox"/> Perform all ROAD TESTING and mark required procedures.	AT-21		
	3-1 Check before engine is started. <input type="checkbox"/> SELF-DIAGNOSTIC PROCEDURE — Mark detected items. <table style="width: 100%; border: none;"> <tr> <td style="width: 50%; vertical-align: top;"> <input type="checkbox"/> 1. Revolution sensor  <input type="checkbox"/> 2. Vehicle speed sensor  <input type="checkbox"/> 3. Throttle position sensor  <input type="checkbox"/> 4. Shift-solenoid valve A  <input type="checkbox"/> 5. Shift-solenoid valve B  <input type="checkbox"/> 6. Overrun clutch solenoid valve  <input type="checkbox"/> 7. Torque converter clutch solenoid valve             </td> <td style="width: 50%; vertical-align: top;"> <input type="checkbox"/> 8. Fluid temperature sensor and A/T control unit power source  <input type="checkbox"/> 9. Engine speed signal  <input type="checkbox"/> A. Turbine revolution sensor  <input type="checkbox"/> B. Line pressure solenoid valve  <input type="checkbox"/> C. Engine control circuit  <input type="checkbox"/> D. Battery  <input type="checkbox"/> A/T check. Others             </td> </tr> </table>	<input type="checkbox"/> 1. Revolution sensor <input type="checkbox"/> 2. Vehicle speed sensor <input type="checkbox"/> 3. Throttle position sensor <input type="checkbox"/> 4. Shift-solenoid valve A <input type="checkbox"/> 5. Shift-solenoid valve B <input type="checkbox"/> 6. Overrun clutch solenoid valve <input type="checkbox"/> 7. Torque converter clutch solenoid valve	<input type="checkbox"/> 8. Fluid temperature sensor and A/T control unit power source <input type="checkbox"/> 9. Engine speed signal <input type="checkbox"/> A. Turbine revolution sensor <input type="checkbox"/> B. Line pressure solenoid valve <input type="checkbox"/> C. Engine control circuit <input type="checkbox"/> D. Battery <input type="checkbox"/> A/T check. Others	AT-22
<input type="checkbox"/> 1. Revolution sensor <input type="checkbox"/> 2. Vehicle speed sensor <input type="checkbox"/> 3. Throttle position sensor <input type="checkbox"/> 4. Shift-solenoid valve A <input type="checkbox"/> 5. Shift-solenoid valve B <input type="checkbox"/> 6. Overrun clutch solenoid valve <input type="checkbox"/> 7. Torque converter clutch solenoid valve	<input type="checkbox"/> 8. Fluid temperature sensor and A/T control unit power source <input type="checkbox"/> 9. Engine speed signal <input type="checkbox"/> A. Turbine revolution sensor <input type="checkbox"/> B. Line pressure solenoid valve <input type="checkbox"/> C. Engine control circuit <input type="checkbox"/> D. Battery <input type="checkbox"/> A/T check. Others			
	3-2. Check at idle <input type="checkbox"/> Diagnostic Procedure 1 (Engine starts only in P and N position) <input type="checkbox"/> Diagnostic Procedure 2 (In P position, vehicle does not move when pushed) <input type="checkbox"/> Diagnostic Procedure 3 (In N position, vehicle moves when pushed) <input type="checkbox"/> Diagnostic Procedure 4 (Select shock. N → R position) <input type="checkbox"/> Diagnostic Procedure 5 (Vehicle creeps backward in R position) <input type="checkbox"/> Diagnostic Procedure 6 (Vehicle creeps forward in D, 3, 2 or 1 position)	AT-22		
	3-3. Cruise test Part-1 <input type="checkbox"/> Diagnostic Procedure 7 (Vehicle starts from D <sub>1</sub> ) <input type="checkbox"/> Diagnostic Procedure 8 <input type="checkbox"/> Diagnostic Procedure 9 } (A/T shift schedule: D <sub>1</sub> → D <sub>2</sub> /D <sub>2</sub> → D <sub>3</sub> /D <sub>3</sub> → D <sub>4</sub> ) <input type="checkbox"/> Diagnostic Procedure 10 } <input type="checkbox"/> Diagnostic Procedure 11 (Shift schedule: Lock-up) <input type="checkbox"/> Diagnostic Procedure 12 (Lock-up condition more than 30 seconds) <input type="checkbox"/> Diagnostic Procedure 13 (Lock up released) <input type="checkbox"/> Diagnostic Procedure 14 (Engine speed return to idle. Light braking D <sub>4</sub> → D <sub>3</sub> )	AT-27		

GI

MA

EM

LC

EF &  
EC

FE

AT

PD

FA

RA

BR

ST

RS

BT

HA

EL

IDX

## TROUBLE DIAGNOSES

### How to Perform Trouble Diagnoses for Quick and Accurate Repair (Cont'd)

	<p><b>Part-2</b></p> <ul style="list-style-type: none"> <li><input type="checkbox"/> Diagnostic Procedure 15 (Vehicle starts from D<sub>1</sub>)</li> <li><input type="checkbox"/> Diagnostic Procedure 16 (Kickdown: D<sub>4</sub> → D<sub>2</sub>)</li> <li><input type="checkbox"/> Diagnostic Procedure 9 (Shift schedule: D<sub>2</sub> → D<sub>3</sub>)</li> <li><input type="checkbox"/> Diagnostic Procedure 10 (Shift schedule: D<sub>3</sub> → D<sub>4</sub> and engine brake)</li> <li><input type="checkbox"/> Diagnostic Procedure 17 (Kickdown: D<sub>2</sub> → D<sub>1</sub>)</li> </ul>	AT-29
	<p><b>Part-3</b></p> <ul style="list-style-type: none"> <li><input type="checkbox"/> Diagnostic Procedure 18 (D<sub>4</sub> → D<sub>3</sub> when selector lever D → 3 position)</li> <li><input type="checkbox"/> Diagnostic Procedure 14 (Engine brake in 3<sub>3</sub>)</li> <li><input type="checkbox"/> Diagnostic Procedure 19 (3<sub>3</sub> → 2<sub>2</sub> when selector lever 3 → 2 position)</li> <li><input type="checkbox"/> Diagnostic Procedure 14 (Engine brake in 2<sub>2</sub>)</li> <li><input type="checkbox"/> Diagnostic Procedure 20 (2<sub>2</sub> (1<sub>2</sub>) → 1<sub>1</sub>, when selector lever 2 → 1 position)</li> <li><input type="checkbox"/> Diagnostic Procedure 21 (Engine brake in 1<sub>1</sub>)</li> <li><input type="checkbox"/> SELF-DIAGNOSTIC PROCEDURE — Mark detected items. <ul style="list-style-type: none"> <li><input type="checkbox"/> 1. Revolution sensor</li> <li><input type="checkbox"/> 2. Vehicle speed sensor</li> <li><input type="checkbox"/> 3. Throttle position sensor</li> <li><input type="checkbox"/> 4. Shift-solenoid valve A</li> <li><input type="checkbox"/> 5. Shift-solenoid valve B</li> <li><input type="checkbox"/> 6. Overrun clutch solenoid valve</li> <li><input type="checkbox"/> 7. Torque converter clutch solenoid valve</li> <li><input type="checkbox"/> 8. Fluid temperature sensor and A/T control unit power source</li> <li><input type="checkbox"/> 9. Engine speed signal</li> <li><input type="checkbox"/> A. Turbine revolution sensor</li> <li><input type="checkbox"/> B. Line pressure solenoid valve</li> <li><input type="checkbox"/> C. Engine control circuit</li> <li><input type="checkbox"/> D. Battery</li> <li><input type="checkbox"/> A/T check. Others</li> </ul> </li> </ul>	AT-30
4.	<ul style="list-style-type: none"> <li><input type="checkbox"/> Perform the Diagnostic Procedures marked in ROAD TESTING. Refer to the Symptom Chart when you perform the procedures. (The chart also shows some other possible symptoms and the components inspection orders.)</li> </ul>	AT-88
5.	<p>Perform FINAL CHECK. If NG, go back to "CHECK A/T FLUID".</p> <ul style="list-style-type: none"> <li><input type="checkbox"/> Stall test — Mark possible damaged components/others. <ul style="list-style-type: none"> <li><input type="checkbox"/> Torque converter one-way clutch</li> <li><input type="checkbox"/> Reverse clutch</li> <li><input type="checkbox"/> Forward clutch</li> <li><input type="checkbox"/> Overrun clutch</li> <li><input type="checkbox"/> Forward one-way clutch</li> <li><input type="checkbox"/> Low &amp; reverse brake</li> <li><input type="checkbox"/> Low one-way clutch</li> <li><input type="checkbox"/> Engine</li> <li><input type="checkbox"/> Line pressure is low</li> <li><input type="checkbox"/> Clutches and brakes except high clutch and brake band are OK.</li> </ul> </li> <li><input type="checkbox"/> Pressure test — Suspected parts:</li> </ul>	AT-84



## Fail-Safe Remarks

The A/T control unit has an electronic Fail-Safe (limp home mode). This allows the vehicle to be driven even if a major electrical input/output device circuit is damaged.

In this condition, the vehicle runs in third gear in positions 1, 2 or D and will not upshift. Customer may say "Sluggish, poor acceleration".

When Fail-safe operation occurs the next time the key is turned to the ON position, the diagnostic information display will display "Transmission malfunction". (For diagnosis, refer to AT-22.)

GI

MA

## Remarks

Fail-safe may occur without electrical circuit damage if the vehicle is driven under extreme conditions (such as excessive wheel spin followed by sudden braking). To recover normal shift pattern, turn ignition key OFF for 3 seconds, then ON.

EM

The indication by the diagnostic information display will appear only once and be cleared. The customer may resume normal driving conditions by chance.

LC

Always follow the "WORK FLOW" (Refer to AT-13).

The SELF-DIAGNOSIS results will be as follows:

EF &  
EC

The first SELF-DIAGNOSIS will indicate the damage of the vehicle speed sensor or the revolution sensor.

FE

During the next SELF-DIAGNOSIS performed after checking the sensor, no damages will be indicated.

AT

PD

FA

RA

BR

ST

RS

BT

HA

EL

IDX

# TROUBLE DIAGNOSES

## Diagnosis by CONSULT

### NOTICE

1. The CONSULT electrically displays shift timing and lock-up timing (that is, operation timing of each solenoid).  
Check for time difference between actual shift timing and the CONSULT display. If the difference is noticeable, mechanical parts (except solenoids, sensors, etc.) may be malfunctioning. Check mechanical parts using applicable diagnostic procedures.
2. Shift schedule (which implies gear position) displayed on CONSULT and that indicated in Service Manual may differ slightly. This occurs because of the following reasons:
  - Actual shift schedule has more or less tolerance or allowance,
  - Shift schedule indicated in Service Manual refers to the point where shifts start, and gear position displayed on CONSULT indicates the point where shifts are completed.
3. Shift solenoid valve "A" or "B" is displayed on CONSULT at the start of shifting while gear position is displayed upon completion of shifting (which is computed by A/T control unit).
4. Additional CONSULT information can be found in the Operation Manual supplied with the CONSULT unit.

### APPLICATION

Item	Display	Monitor item		Description	Remarks
		ECU input signals	Main signals		
Vehicle speed sensor 1 (A/T) (Revolution sensor)	VHCL/S SE-A/T [km/h] or [mph]	X	—	● Vehicle speed computed from signal of revolution sensor is displayed.	When racing engine in N or P position with vehicle stationary, CONSULT data may not indicate 0 km/h (0 mph).
Vehicle speed sensor 2 (Meter)	VHCL/S SE-MTR [km/h] or [mph]	X	—	● Vehicle speed computed from signal of vehicle speed sensor is displayed.	Vehicle speed display may not be accurate under approx. 10 km/h (6 mph). It may not indicate 0 km/h (0 mph) when vehicle is stationary.
Throttle position sensor	THRTL POS SEN [V]	X	—	● Throttle position sensor signal voltage is displayed.	
Fluid temperature sensor	FLUID TEMP SEN [V]	X	—	● Fluid temperature sensor signal voltage is displayed. ● Signal voltage lowers as fluid temperature rises.	
Battery voltage	BATTERY VOLT [V]	X	—	● Source voltage of control unit is displayed.	
Engine speed	ENG SPEED [rpm]	X	X	● Engine speed, computed from engine speed signal, is displayed.	Error may occur under approx. 800 rpm and meter will not indicate 0 rpm even if engine is not running.
Turbine revolution sensor	TURBINE REV [rpm]	X	—	● Turbine revolution computed from signal of turbine revolution sensor is displayed.	Error may occur under approx. 800 rpm and meter will not indicate 0 rpm even if engine is not running.
P/N position switch	P/N POSI SW [ON/OFF]	X	—	● ON/OFF state computed from signal of P/N position SW is displayed.	
R position switch	R POSITION SW [ON/OFF]	X	—	● ON/OFF state computed from signal of R position SW is displayed.	
D position switch	D POSITION SW [ON/OFF]	X	—	● ON/OFF state computed from signal of D position SW is displayed.	
4 position switch	4 POSITION SW [ON/OFF]	—	—		
3 position switch	3 POSITION SW [ON/OFF]	X	—	● ON/OFF state computed from signal of 3 position SW is displayed.	

# TROUBLE DIAGNOSES

## Diagnosis by CONSULT (Cont'd)

Item	Display	Monitor item		Description	Remarks
		ECU input signals	Main signals		
2 position switch	2 POSITION SW [ON/OFF]	X	—	● ON/OFF status, computed from signal of 2 position SW, is displayed.	
1 position switch	1 POSITION SW [ON/OFF]	X	—	● ON/OFF status, computed from signal of 1 position SW, is displayed.	
ASCD-cruise signal	ASCD-CRUIS [ON/OFF]	X	—	● Status of ASCD cruise signal is displayed. ON ... Cruising state OFF ... Normal running state	● This is displayed even when no ASCD is mounted.
ASCD-OD cut signal	ASCD-OD CUT [ON/OFF]	X	—	● Status of ASCD-OD release signal is displayed. ON ... OD released OFF ... OD not released	● This is displayed even when no ASCD is mounted.
Kickdown switch	KICKDOWN SW [ON/OFF]	X	—	● ON/OFF status, computed from signal of kickdown SW, is displayed.	
Closed throttle position switch	CLOSE THL/SW [ON/OFF]	X	—	● ON/OFF status, computed from signal of closed throttle position SW, is displayed.	
Wide open throttle position switch	W/O THR/P-SW [ON/OFF]	X	—	● ON/OFF status, computed from signal of wide open throttle position SW, is displayed.	
Gear position	GEAR		X	● Gear position data used for computation by control unit, is displayed.	
Selector lever position	RANGE or SLCT LVR POSI		X	● Selector lever position data, used for computation by control unit, is displayed.	● A specific value used for control is displayed if fail-safe is activated due to error.
Vehicle speed	VEHICLE SPEED [km/h] or [mph]		X	● Vehicle speed data, used for computation by control unit, is displayed.	
Throttle position	THROTTLE POSI [°]		X	● Throttle position data, used for computation by control unit, is displayed.	● A specific value used for control is displayed if fail-safe is activated due to error.
Line pressure duty	LINE PRES DUTY [%]		X	● Control value of line pressure solenoid valve, computed by control unit from each input signal, is displayed.	
Lock-up duty	TCC S/V DUTY [%]		X	● Control value of torque converter clutch solenoid valve, computed by control unit from each input signal, is displayed.	
Shift solenoid valve A	SHIFT SOL/V A [ON/OFF]	—	X	● Control value of shift solenoid valve A, computed by control unit from each input signal, is displayed.	Control value of solenoid is displayed even if solenoid circuit is disconnected. The "OFF" signal is displayed if solenoid circuit is shorted.
Shift solenoid valve B	SHIFT SOL/V B [ON/OFF]	—	X	● Control value of shift solenoid valve B, computed by control unit from each input signal, is displayed.	
Overrun clutch solenoid valve	OVERRUN/C SOL/V [ON/OFF]	—	X	● Control value of overrun clutch solenoid valve computed by control unit from each input signal is displayed.	

# TROUBLE DIAGNOSES

## Diagnosis by CONSULT (Cont'd)

Item	Display	Monitor item		Description	Remarks
		ECU input signals	Main signals		
Power shift lamp	POWER SHIFT LAMP	—	—	● Control status of power shift lamp is displayed.	
Power shift switch	POWER SHIFT SW	—	—	● ON/OFF status, computed from signal of power shift SW, is displayed.	● This is displayed even when no power SW is equipped. On vehicles with power SW mounted on lever, this item is invalid although displayed.
Hold switch	HOLD SW	—	—	● ON/OFF status, computed from signal of hold SW, is displayed.	

X: Applicable

—: Not applicable

Note:

1. When select ECU input signals on CONSULT, electronic control unit input signal are set.
2. When selecting main signals on CONSULT, monitored items for understanding overall system operation are set. This setting is indicated by a reversed display.

### DATA ANALYSIS

Item	Display form	Meaning
Lock-up duty	Approximately 4%	Lock-up "OFF"
	↓ Approximately 94%	↓ Lock-up "ON"
Line pressure duty	Approximately 29%	Low line-pressure (Small throttle opening)
	↓ Approximately 94%	↓ High line-pressure (Large throttle opening)
Throttle position sensor	Approximately 0.5V	Fully-closed throttle
	Approximately 4V	Fully-open throttle
Fluid temperature sensor	Approximately 1.5V	Cold [20°C (68°F)]
	↓ Approximately 0.5V	↓ Hot [80°C (176°F)]

Gear position	1	2	3	4
Shift solenoid valve A	ON	OFF	OFF	ON
Shift solenoid valve B	ON	ON	OFF	OFF

## Preliminary Check

### A/T FLUID CHECK

#### Fluid leakage check

1. Clean area suspected of leaking, — for example, mating surface of converter housing and transmission case.
2. Start engine, apply foot brake, place selector lever in "D" position and wait a few minutes.
3. Stop engine.
4. Check for fresh leakage.

#### Fluid condition check

Fluid color	Suspected problem
Dark or black with burned odor	Wear of frictional material
Milky pink	Water contamination — Road water entering through filler tube or breather
Varnished fluid, light to dark brown and tacky	Oxidation — Over or under filling, overheating

**Fluid level check — Refer to MA section (CHASSIS AND BODY MAINTENANCE).**

### ROAD TEST PROCEDURE

1. Check before engine is started.



2. Check at idle.



3. Cruise test.

SAT786A

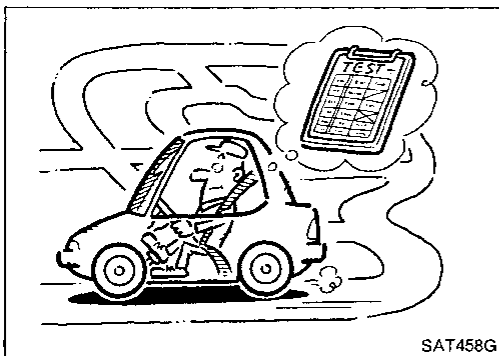

SAT458G

### ROAD TESTING

#### Description

- The purpose of this test is to analyze overall performance and determine causes of problems.
- The road test consists of the following three parts:
  1. Check before engine is started
  2. Check at idle
  3. Cruise test
- Before road test, familiarize yourself with all test procedures and items to check.
- Conduct tests on all items. Troubleshoot items which check out No Good after road test. Refer to "Self-diagnosis" and "Diagnostic Procedure", AT-40.

# TROUBLE DIAGNOSES

## Preliminary Check (Cont'd)

### 1. Check before engine is started

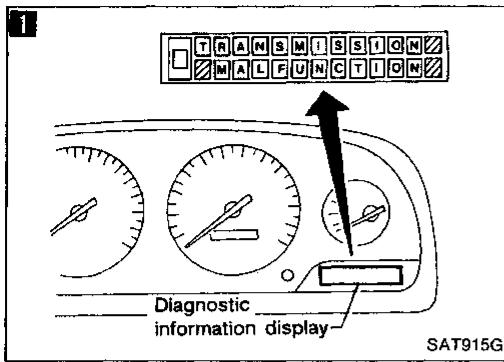

**1**

1. Park vehicle on flat surface.
2. Turn ignition switch to "OFF" position.
3. Move selector lever to "P" position.
4. Turn ignition switch to "ON" position. (Do not start engine.)
5. Is the judgement "Transmission malfunction" displayed on diagnostic information display?

Yes → Perform self-diagnosis. — Refer to SELF-DIAGNOSIS PROCEDURE, AT-40.

No ↓

1. Turn ignition switch to "OFF" position.
2. Perform self-diagnosis. — Refer to SELF-DIAGNOSIS PROCEDURE AT-40 and note N.G. items.
3. Go to "ROAD TESTING — 2. Check at idle".

### 2. Check at idle

1. Park vehicle on flat surface.
2. Turn ignition switch to "OFF" position.
3. Move selector lever to "P" or "N" position.
4. Turn ignition switch to "START" position.
5. Is engine started?

No → Go to Diagnostic Procedure 1, AT-59.

Yes ↓

1. Turn ignition switch to "OFF" position.
2. Move selector lever to "D", "1", "2", "3" or "R" position.
3. Turn ignition switch to "START" position.
4. Is engine started?

Yes → Go to Diagnostic Procedure 1, AT-59.

No ↓

**1**

1. Turn ignition switch to "OFF" position.
2. Move selector lever to "P" position.
3. Release parking brake.
4. Push vehicle forward or backward.
5. Does vehicle move when it is pushed forward or backward?

Yes → Go to Diagnostic Procedure 2, AT-59.

No ↓  
Ⓐ

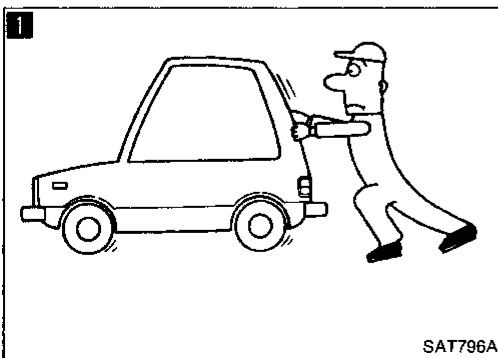

# TROUBLE DIAGNOSES

## Preliminary Check (Cont'd)

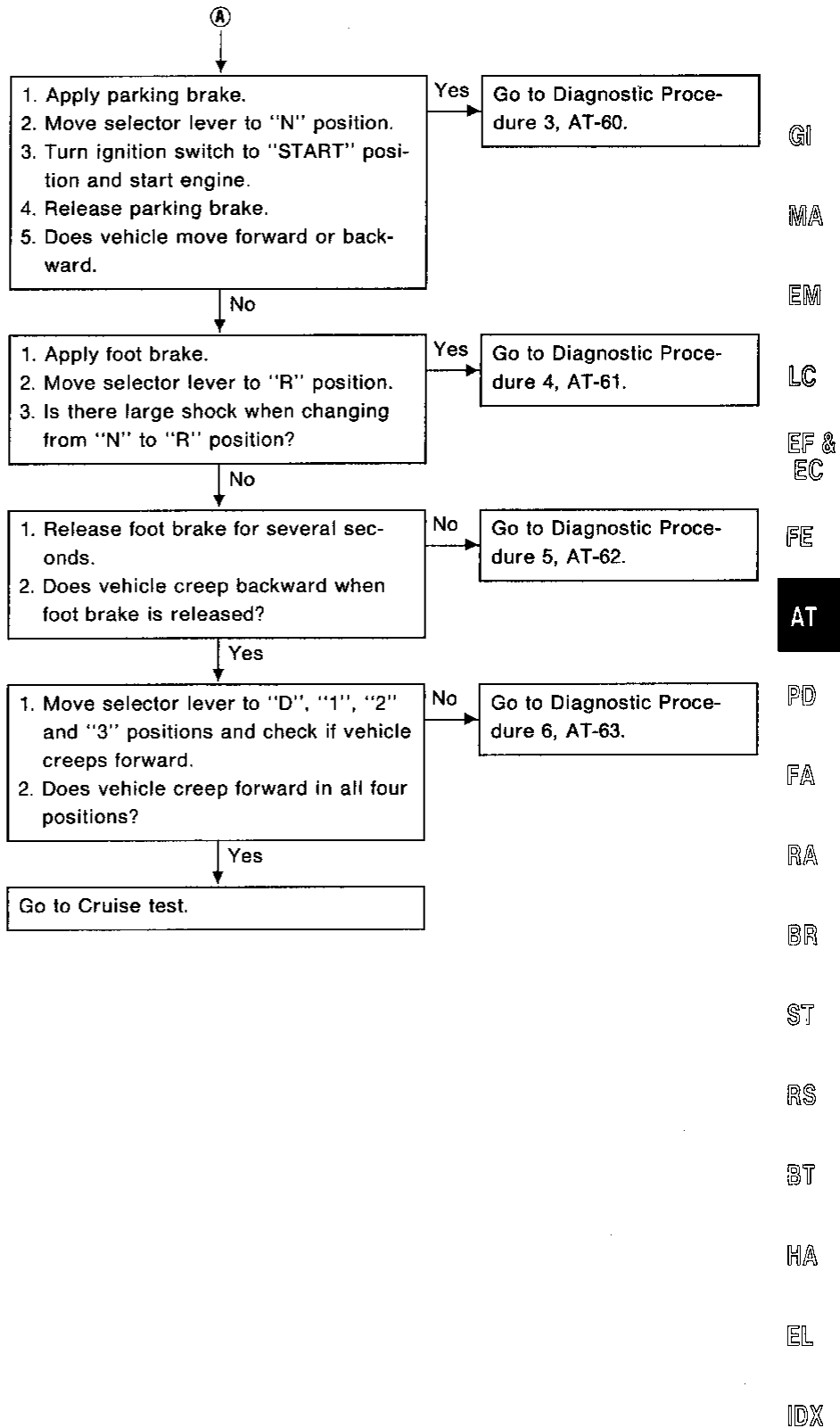

# TROUBLE DIAGNOSES

## Preliminary Check (Cont'd)

### 3. Cruise test

#### With CONSULT

- Using CONSULT, conduct a cruise test and record the result.
- Print the result and ensure that shifts and lock-ups take place as per "Shift Schedule".
- Check all items listed in Parts 1 through 3.

#### CONSULT setting procedure

1. Turn off ignition switch.
2. Connect "CONSULT" to data link connector for CONSULT. (Data link connector for CONSULT is located in the fuse box.)

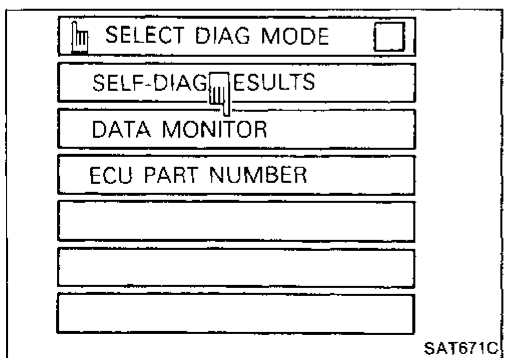
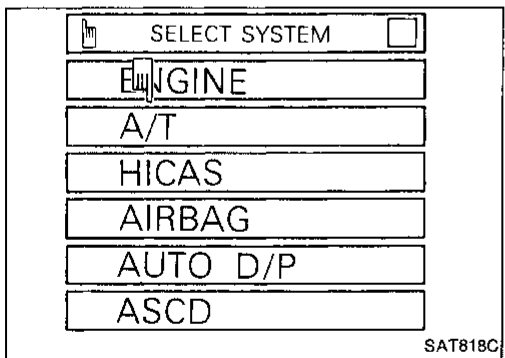
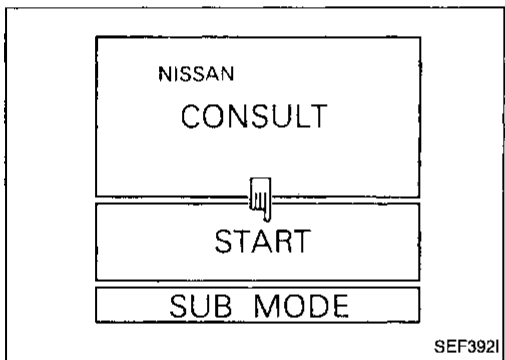
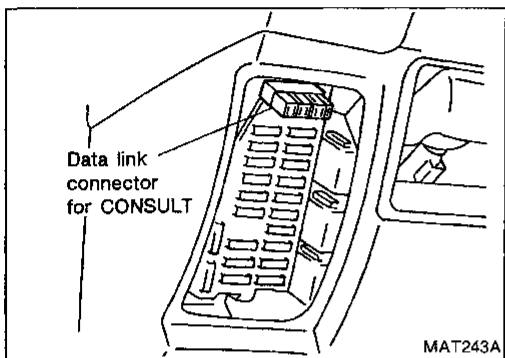
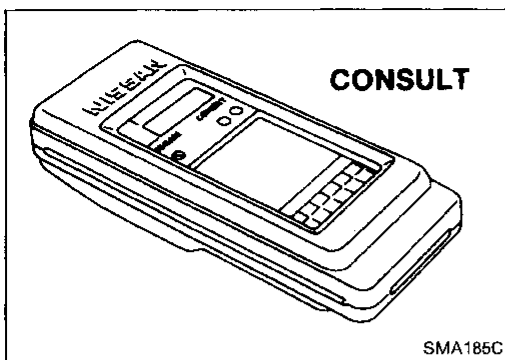

3. Turn on ignition switch.
4. Touch "START".

5. Touch "A/T".

6. Touch "DATA MONITOR".



# TROUBLE DIAGNOSES

## Preliminary Check (Cont'd)

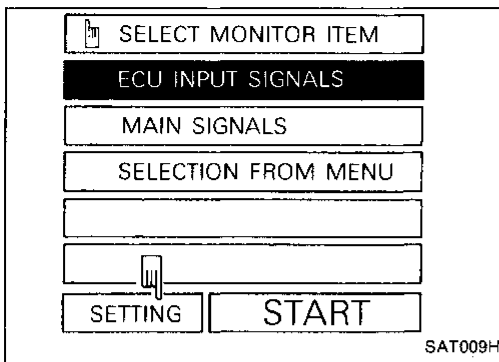

7. Touch "SETTING" to set recording condition.

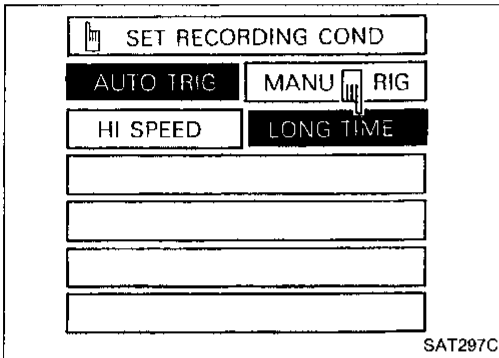

8. Touch "LONG TIME" and "ENTER" key.

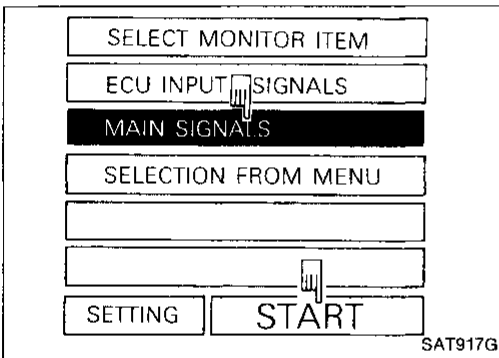

9. Go back to SELECT MONITOR ITEM and touch "MAIN SIGNALS".

10. Touch "START".

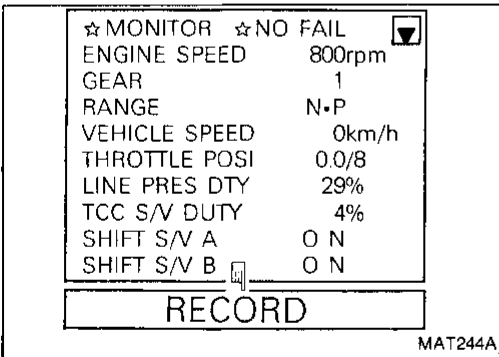

11. When performing cruise test, touch "RECORD".

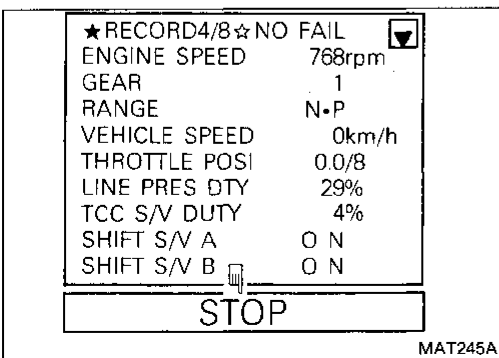

12. After finishing cruise test part 1, touch "STOP".

GI

MA

EM

LC

EF &  
EC

FE

AT

PD

FA

RA

BR

ST

RS

BT

HA

EL

IDX

# TROUBLE DIAGNOSES

## Preliminary Check (Cont'd)

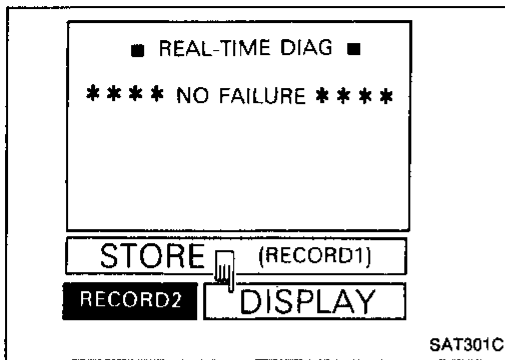

13. Touch "DISPLAY".

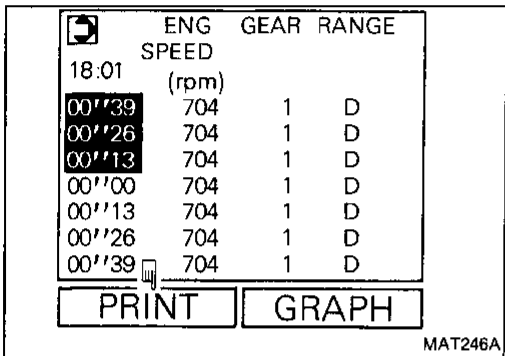

14. Touch "PRINT".

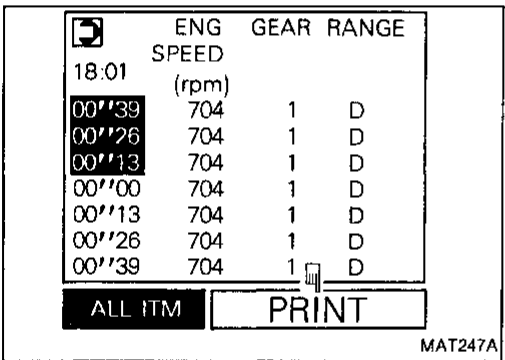

15. Touch "PRINT" again.

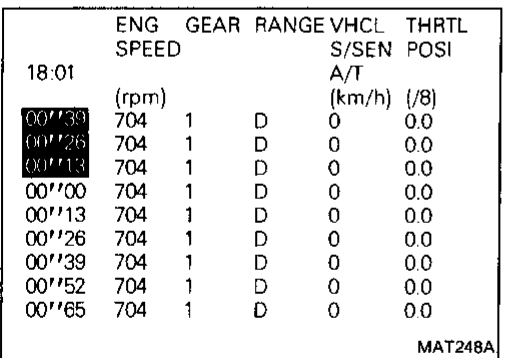

16. Check the monitor data printed out.

17. Continue cruise test part 2 and 3.

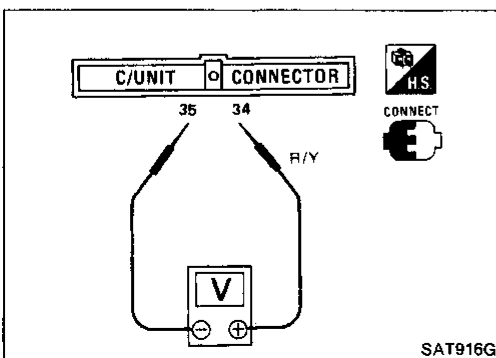

Without CONSULT

- Throttle position can be controlled by voltage across terminals 34 and 35 of A/T control unit.

# TROUBLE DIAGNOSES

## Preliminary Check (Cont'd)

### Cruise test — Part 1

Drive vehicle for about 10 minutes until engine oil and ATF reach operating temperature.

**A.T.F. operating temperature:**  
50 - 80°C (122 - 176°F)

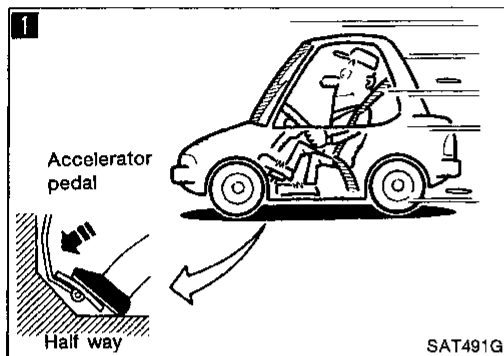

- 1**
1. Park vehicle on flat surface.
  2. Move selector lever to "P" position.
  3. Turn ignition switch to "ON" position and start engine.
  4. Move selector lever to "D" position.
  5. Accelerate vehicle to half throttle.
  6. Does vehicle start from D<sub>1</sub>?
- Read gear position.**

No → Go to Diagnostic Procedure 7, AT-64.

- Yes
- 2**
- Does A/T shift from D<sub>1</sub> to D<sub>2</sub> at the specified speed?
- Read gear position, throttle opening and vehicle speed.**  
**Specified speed when shifting from D<sub>1</sub> to D<sub>2</sub>:**  
**Refer to Shift schedule, AT-32.**

No → Go to Diagnostic Procedure 8, AT-65.

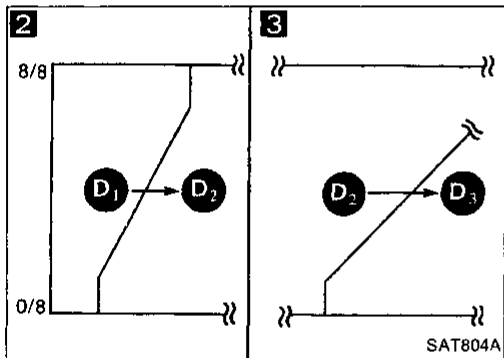

- Yes
- 3**
- Does A/T shift from D<sub>2</sub> to D<sub>3</sub> at the specified speed?
- Read gear position, throttle opening and vehicle speed.**  
**Specified speed when shifting from D<sub>2</sub> to D<sub>3</sub>:**  
**Refer to Shift schedule, AT-32.**

No → Go to Diagnostic Procedure 9, AT-66.

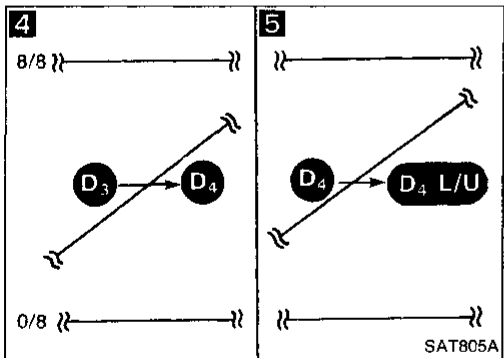

- Yes
- 4**
- Does A/T shift from D<sub>3</sub> to D<sub>4</sub> at the specified speed?
- Read gear position, throttle opening and vehicle speed.**  
**Specified speed when shifting from D<sub>3</sub> to D<sub>4</sub>:**  
**Refer to Shift schedule, AT-32.**

No → Go to Diagnostic Procedure 10, AT-67.

Yes  
Ⓐ

GI

MA

EM

LC

EF &  
EC

FE

**AT**

PD

FA

RA

BR

ST

RS

BT

HA

EL

IDX

# TROUBLE DIAGNOSES

## Preliminary Check (Cont'd)

A

5

Does A/T perform lock-up at the specified speed?



**Read vehicle speed, throttle opening when lock-up duty becomes 94%.**

**Specified speed when lock-up occurs:**

**Refer to Shift schedule, AT-32.**

No

Go to Diagnostic Procedure 11, AT-68.

Yes

Does A/T hold lock-up condition for more than 30 seconds?

No

Go to Diagnostic Procedure 12, AT-69.

Yes

6 7

1. Release accelerator pedal.  
2. Is lock-up released when accelerator pedal is released?

No

Go to Diagnostic Procedure 13, AT-69.

Yes

8 9

1. Decelerate vehicle by applying foot brake lightly.  
2. Does engine speed return to idle smoothly when A/T is shifted from D<sub>4</sub> to D<sub>3</sub>?

No

Go to Diagnostic Procedure 14, AT-70.



**Read gear position and engine speed.**

Yes

1. Stop vehicle.  
2. Go to "Cruise test — Part 2".

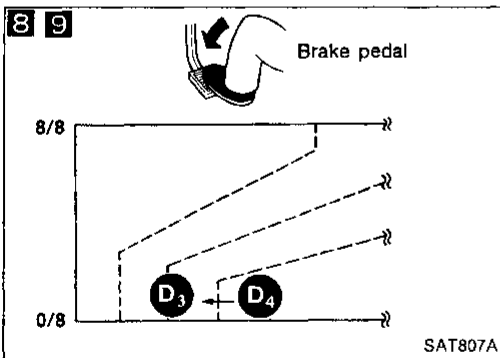
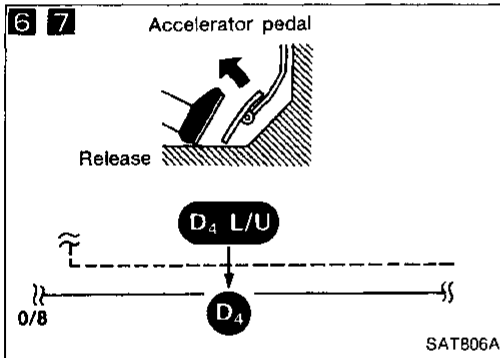

# TROUBLE DIAGNOSES

## Preliminary Check (Cont'd)

### Cruise test — Part 2

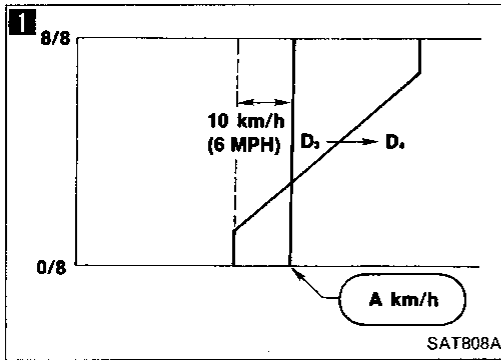

1. Confirm selector lever is in "D" position.
  2. Accelerate vehicle to half throttle again.
  3. Does vehicle start from D<sub>1</sub>?
- Read gear position.**

No → Go to Diagnostic Procedure 15, AT-71.

Yes

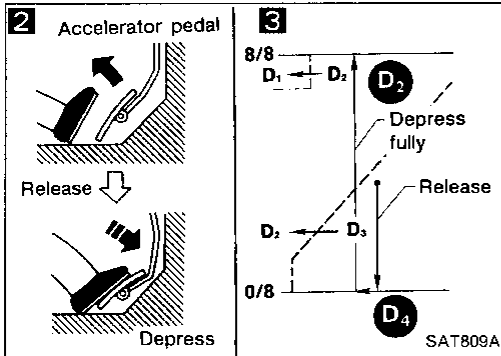

1. Accelerate vehicle to A km/h as shown in illustration.
  2. Release accelerator pedal and then quickly depress it fully.
  3. Does A/T shift from D<sub>4</sub> to D<sub>2</sub> as soon as accelerator pedal is depressed fully?
- Read gear position and throttle opening.**

No → Go to Diagnostic Procedure 16, AT-72.

Yes

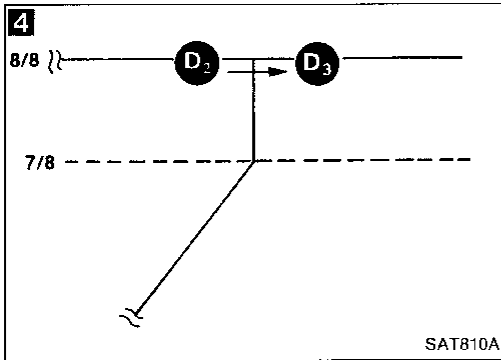

4. Does A/T shift from D<sub>2</sub> to D<sub>3</sub> at the specified speed?
- Read gear position, throttle opening and vehicle speed.**  
**Specified speed when shifting from D<sub>2</sub> to D<sub>3</sub>:**  
 Refer to Shift schedule, AT-32.

No → Go to Diagnostic Procedure 9, AT-66.

Yes

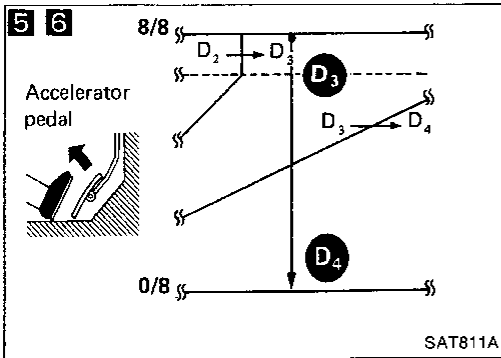

5. Release accelerator pedal after shifting from D<sub>2</sub> to D<sub>3</sub>.
  6. Does A/T shift from D<sub>3</sub> to D<sub>4</sub> and does vehicle decelerate by engine brake?
- Read gear position, throttle opening and vehicle speed.**

No → Go to Diagnostic Procedure 10, AT-67.

Yes

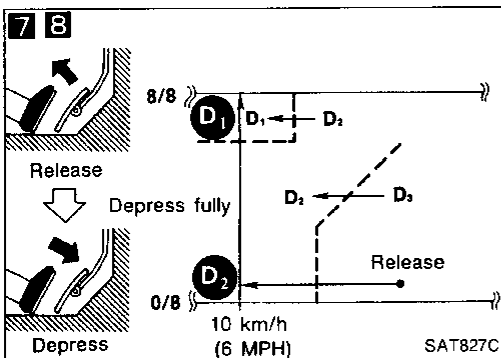

7. Decelerate to 10 km/h (6 MPH) with accelerator pedal released and then quickly depress it fully.
8. Does A/T shift from D<sub>2</sub> to D<sub>1</sub> as soon as accelerator pedal is depressed fully?

No → Go to Diagnostic Procedure 17, AT-73.

Yes

1. Stop vehicle.
2. Go to "Cruise test — Part 3".

# TROUBLE DIAGNOSES

## Preliminary Check (Cont'd)

### Cruise test — Part 3

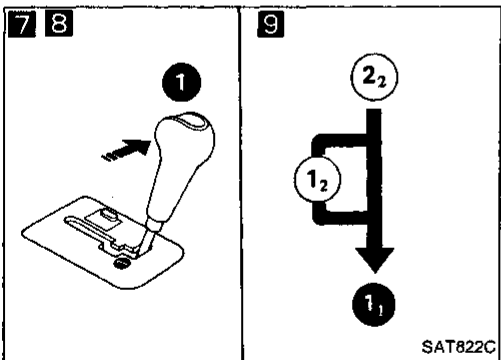
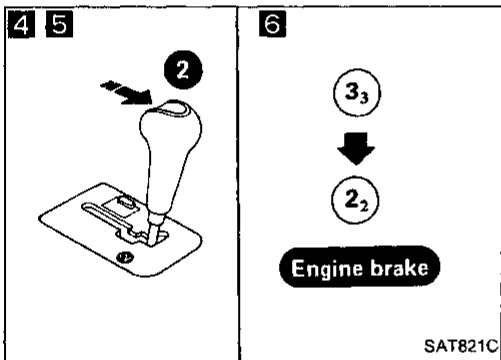
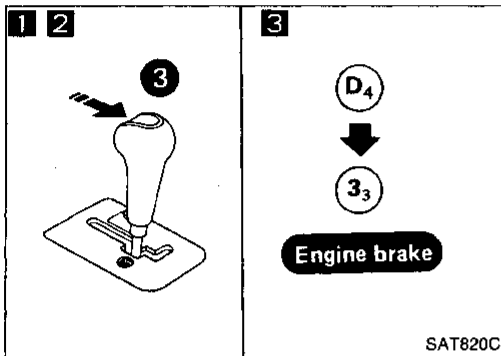

**1 2**

1. Confirm selector lever is in "D" position.
2. Accelerate vehicle, using half throttle, to D<sub>4</sub>.
3. Release accelerator pedal.
4. Move selector lever to "3" position.
5. Does A/T shift from D<sub>4</sub> to 3<sub>3</sub>?

**Read gear position and vehicle speed.**

No → Go to Diagnostic Procedure 18, AT-74.

**3**

Does vehicle decelerate by engine brake?

No → Go to Diagnostic Procedure 14, AT-70.

**4 5**

Move selector lever from "3" to "2" position while driving in 3<sub>3</sub>. Does A/T shift from 3<sub>3</sub> to 2<sub>2</sub>?

**Read gear position.**

No → Go to Diagnostic Procedure 19, AT-74.

**6**

Does vehicle decelerate by engine brake?

No → Go to Diagnostic Procedure 14, AT-70.

**7 8**

Move selector lever from "2" to "1" position while driving in 2<sub>2</sub>. Does A/T shift from 2<sub>2</sub> (1<sub>2</sub>) to 1<sub>1</sub> position?

**Read gear position.**

No → Go to Diagnostic Procedure 20, AT-75.

**9**

Does vehicle decelerate by engine brake?

No → Go to Diagnostic Procedure 21, AT-75.

1. Stop vehicle.
2. Perform self-diagnosis. — Refer to SELF-DIAGNOSIS, AT-40.

# TROUBLE DIAGNOSES

## Preliminary Check (Cont'd)

### Vehicle speed when shifting gears

Throttle position	Vehicle speed km/h (MPH)						
	D <sub>1</sub> → D <sub>2</sub>	D <sub>2</sub> → D <sub>3</sub>	D <sub>3</sub> → D <sub>4</sub>	D <sub>4</sub> → D <sub>3</sub>	D <sub>3</sub> → D <sub>2</sub>	D <sub>2</sub> → D <sub>1</sub>	1 <sub>2</sub> → 1 <sub>1</sub>
Full throttle	78 - 82 (48 - 51)	135 - 143 (84 - 89)	201 - 211 (125 - 131)	194 - 204 (121 - 127)	125 - 133 (78 - 83)	43 - 47 (27 - 29)	53 - 57 (33 - 35)
Half throttle	50 - 54 (31 - 34)	95 - 101 (59 - 63)	138 - 146 (86 - 91)	80 - 88 (50 - 55)	27 - 33 (17 - 21)	10 - 14 (6 - 9)	53 - 57 (33 - 35)

### Vehicle speed when performing and releasing lock-up

Throttle position	Selector lever position [Shift position]	Vehicle speed km/h (MPH)	
		Lock-up "ON"	Lock-up "OFF"
Full throttle	D [D <sub>4</sub> ]	202 - 210 (126 - 130)	195 - 203 (121 - 126)
	3 [3 <sub>3</sub> ]	114 - 122 (71 - 76)	108 - 116 (67 - 72)
Half throttle	D [D <sub>4</sub> ]	138 - 146 (86 - 91)	103 - 111 (64 - 69)
	3 [3 <sub>3</sub> ]	109 - 117 (68 - 73)	103 - 111 (64 - 69)

GI

MA

EM

LC

EF &  
EC

FE

AT

PD

FA

RA

BR

ST

RS

BT

HA

EL

IDX

# TROUBLE DIAGNOSES

## Preliminary Check (Cont'd)

### Shift schedule (D position)

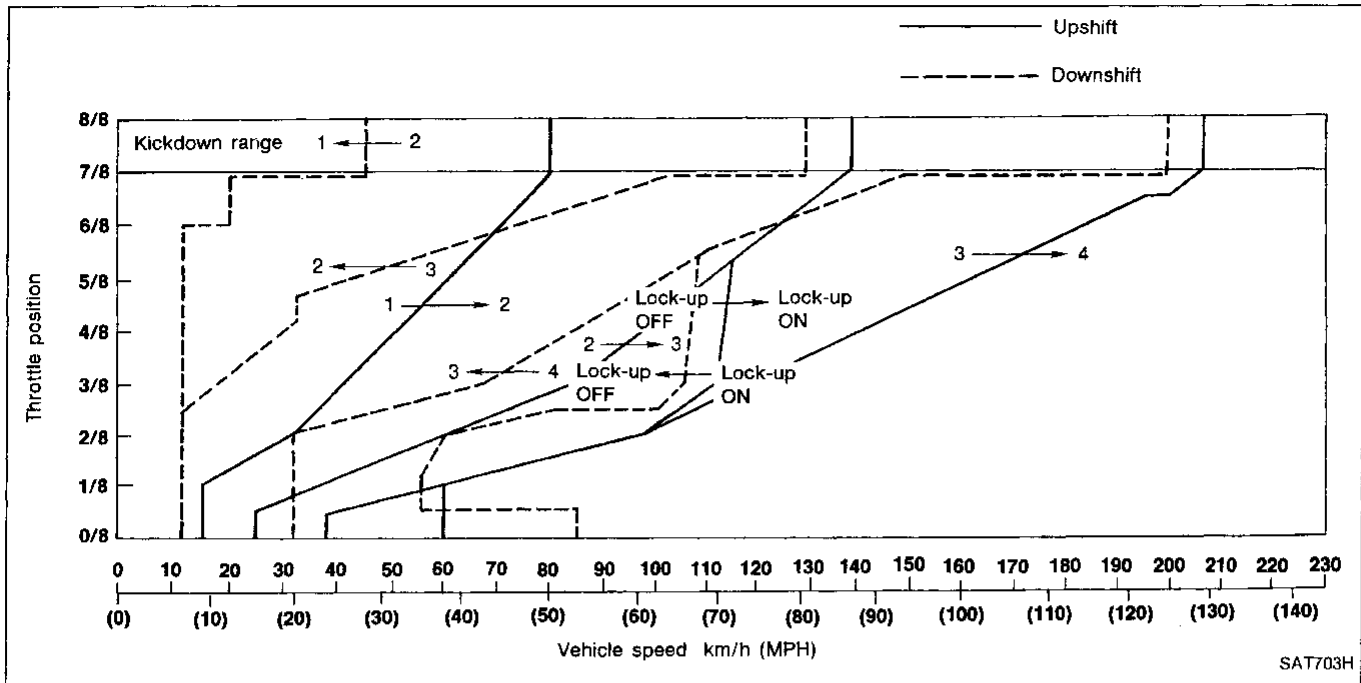

### Shift schedule (Standard pattern in 3 position)

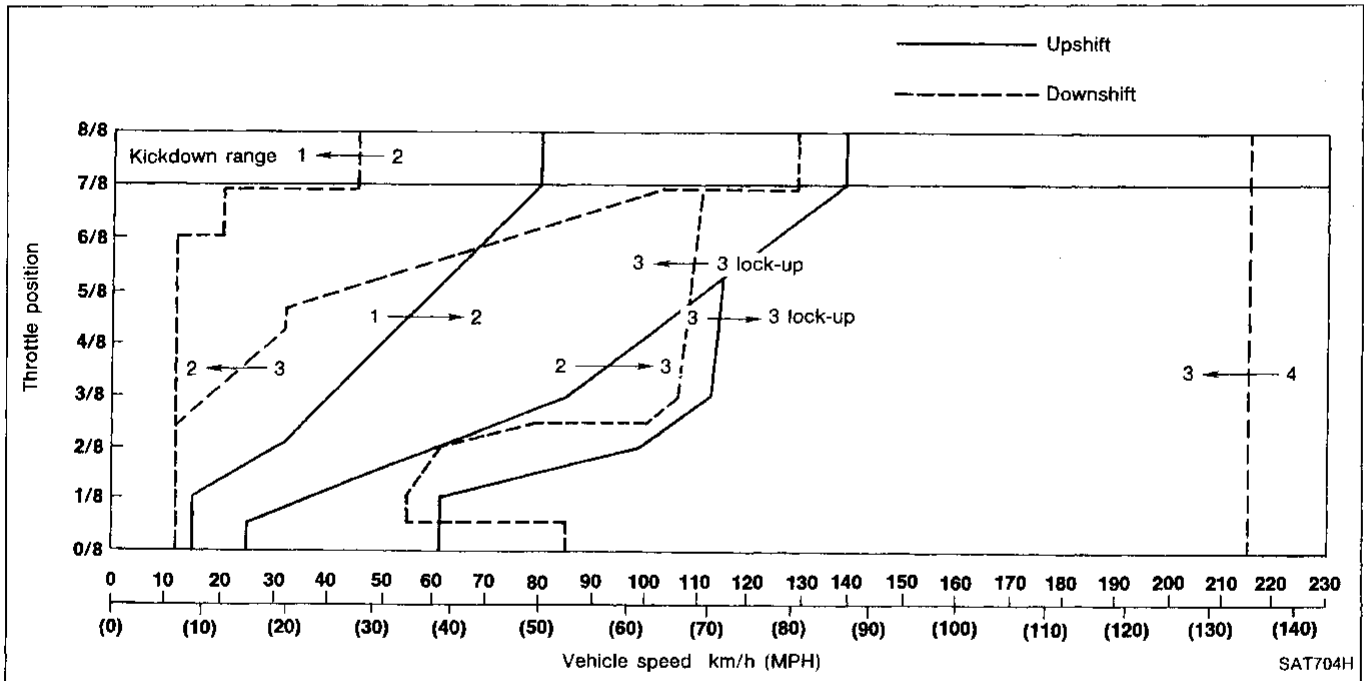



# TROUBLE DIAGNOSES

## Preliminary Check (Cont'd)

### Shift schedule (2 position)

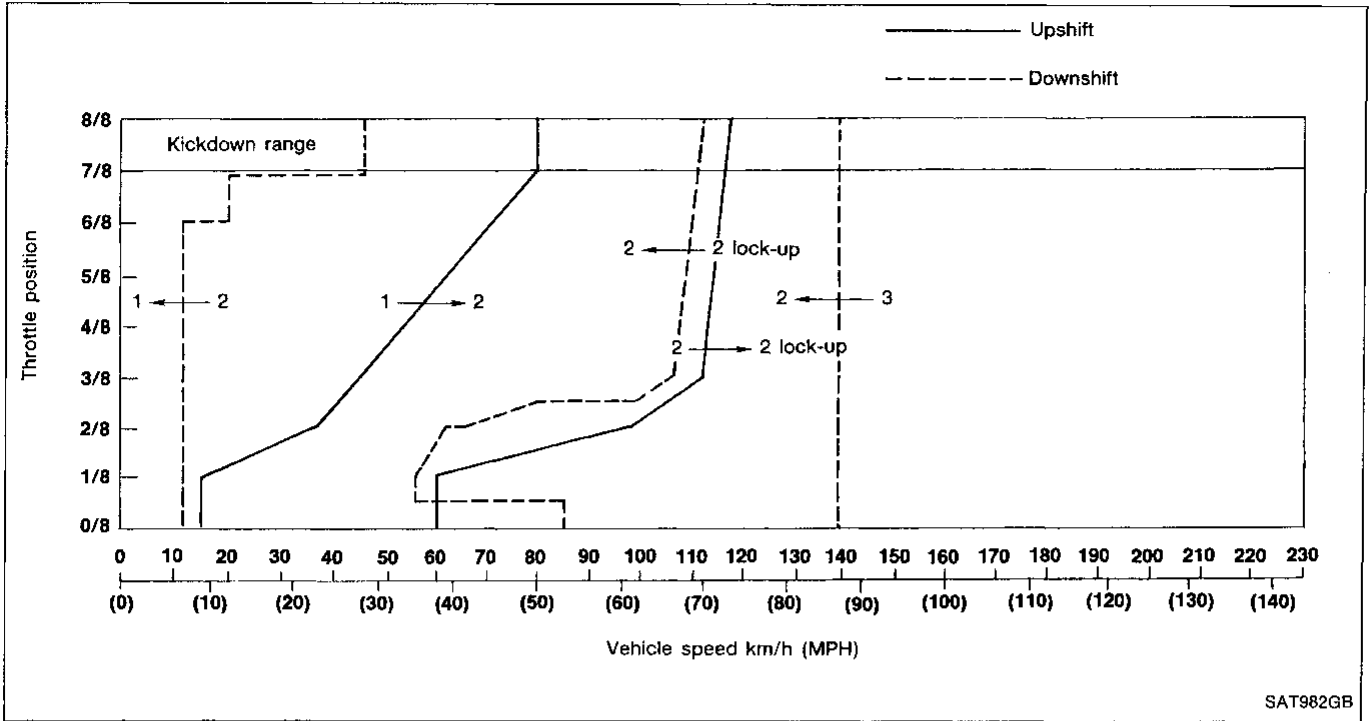

### Shift schedule (1 position)

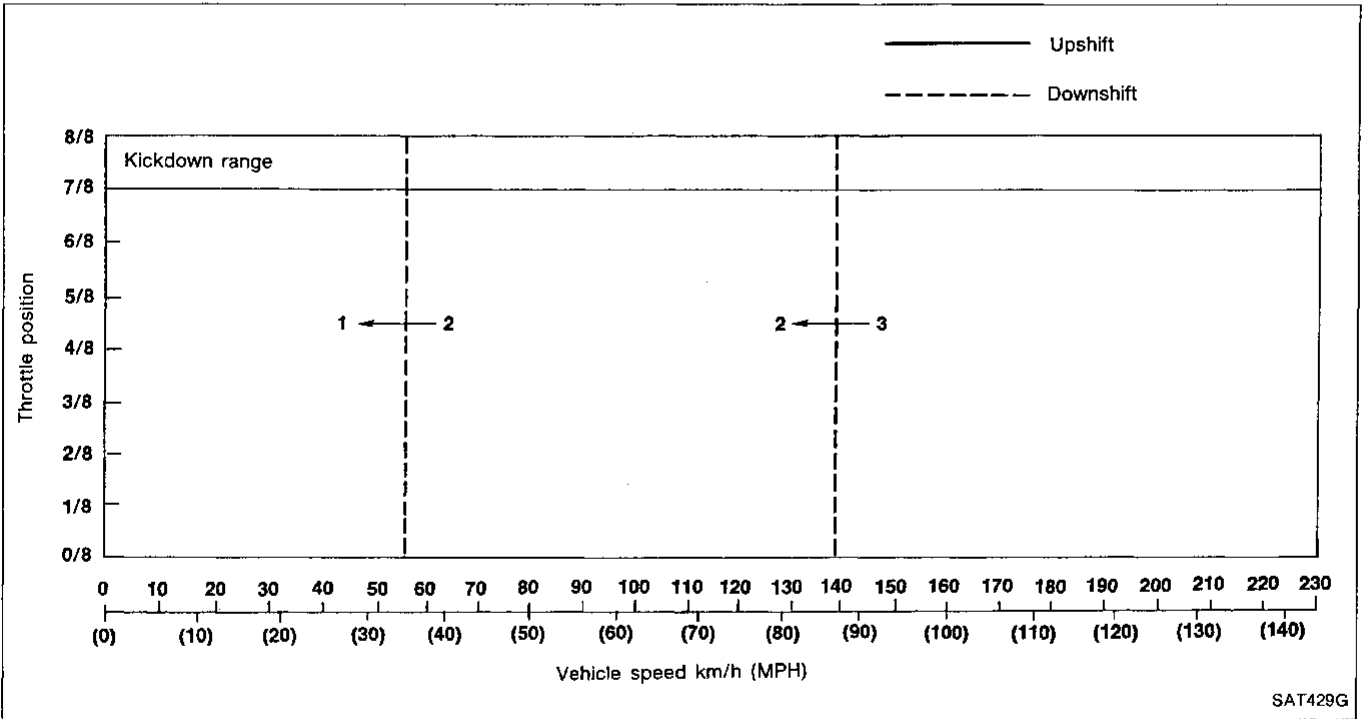

GI  
 MA  
 EM  
 LC  
 EF &  
 EC  
 FE  
 AT  
 PD  
 FA  
 RA  
 BR  
 ST  
 RS  
 BT  
 HA  
 EL  
 DX

## A/T Electrical Parts Location

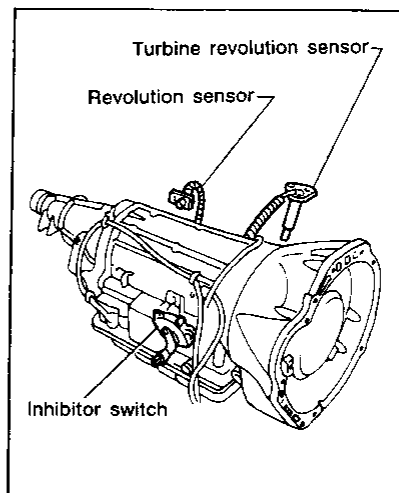
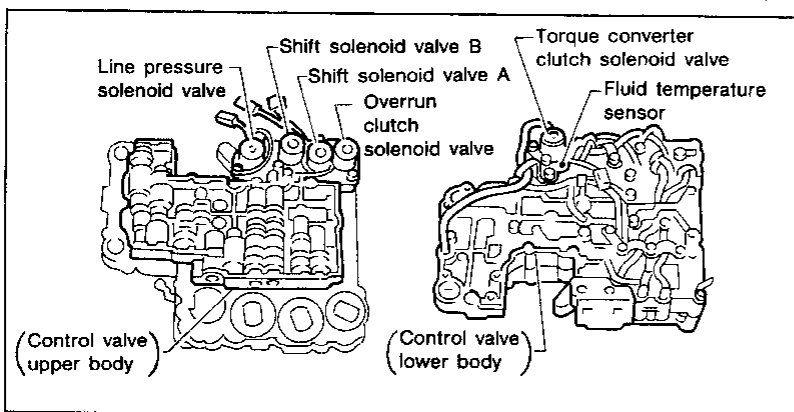
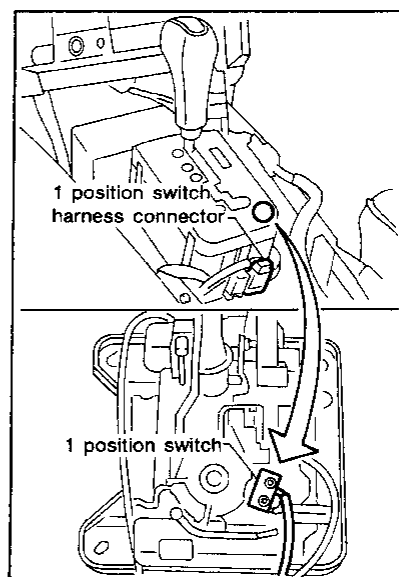
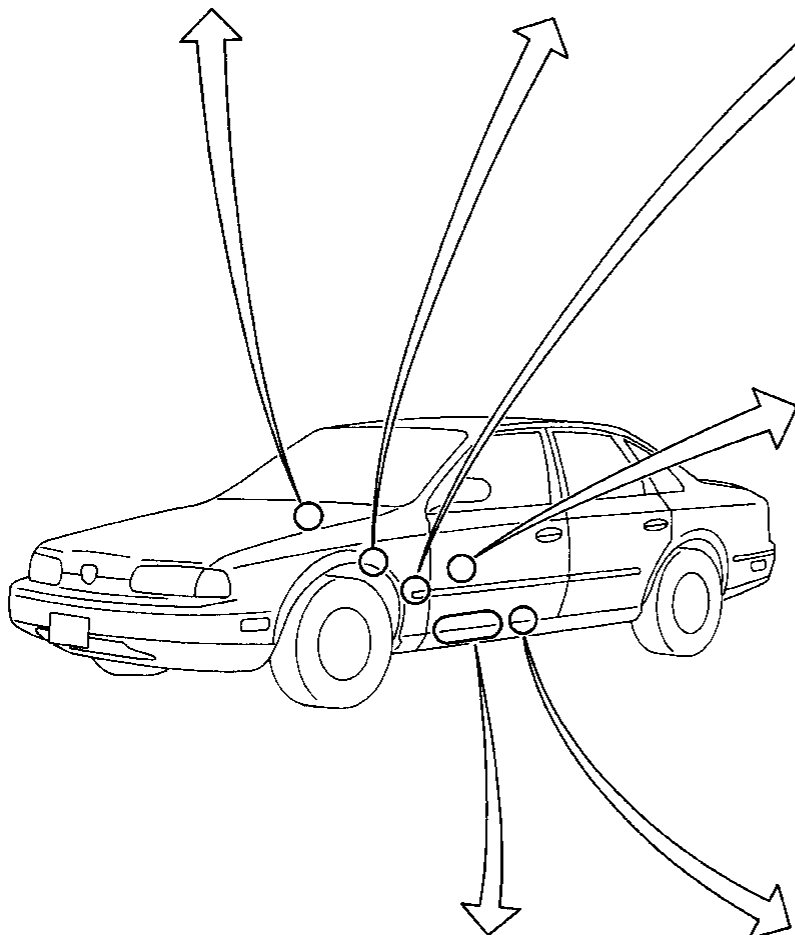
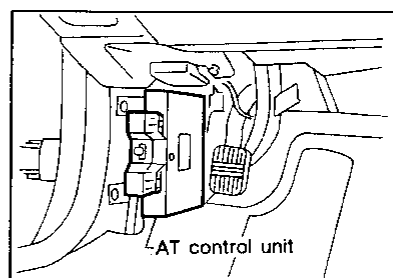
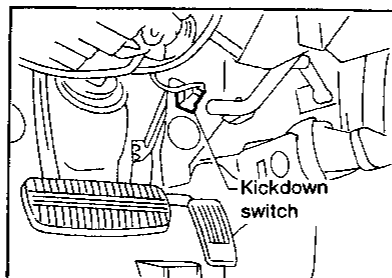
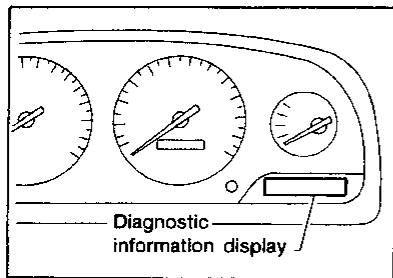

# TROUBLE DIAGNOSES

## A/T Electrical Parts Location (Cont'd)

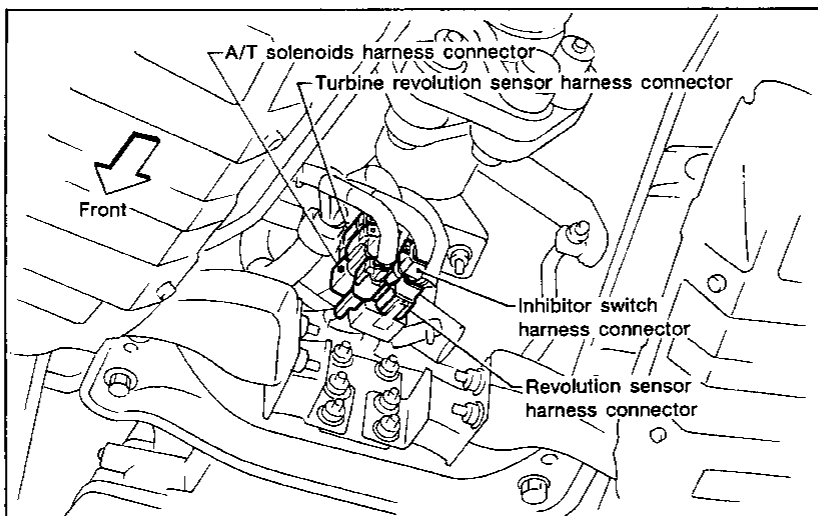
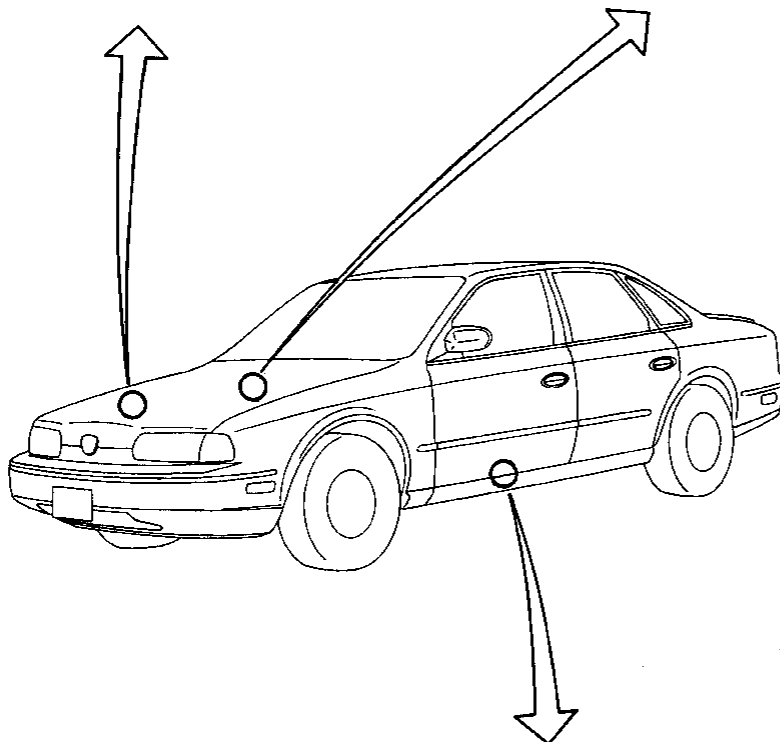
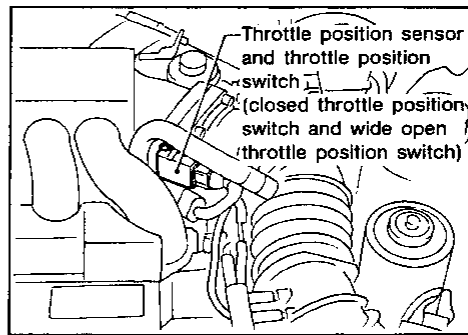
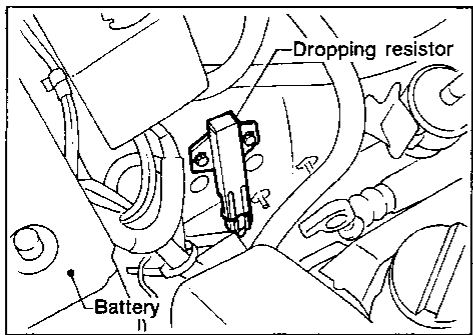

GI

MA

EM

LC

EF &  
EC

FE

**AT**

PD

FA

RA

BR

ST

RS

BT

HA

EL

IDX

# TROUBLE DIAGNOSES

## Circuit Diagram for Quick Pinpoint Check

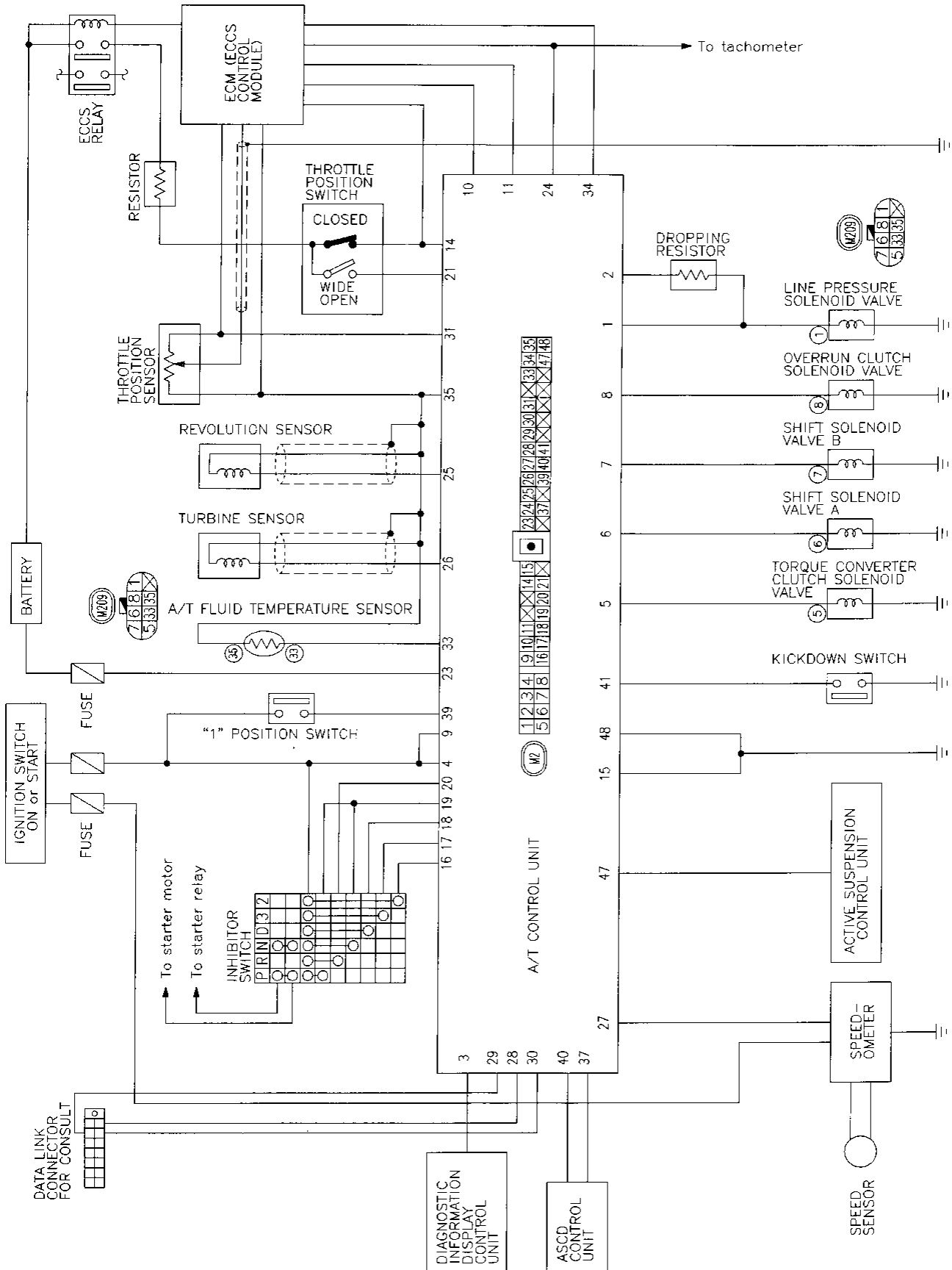

# TROUBLE DIAGNOSES

---

NOTE

GI

MA

EM

LC

EF &  
EC

FE

**AT**

PD

FA

RA

BR

ST

RS

BT

HA

EL

IDX

# TROUBLE DIAGNOSES

## Wiring Diagram

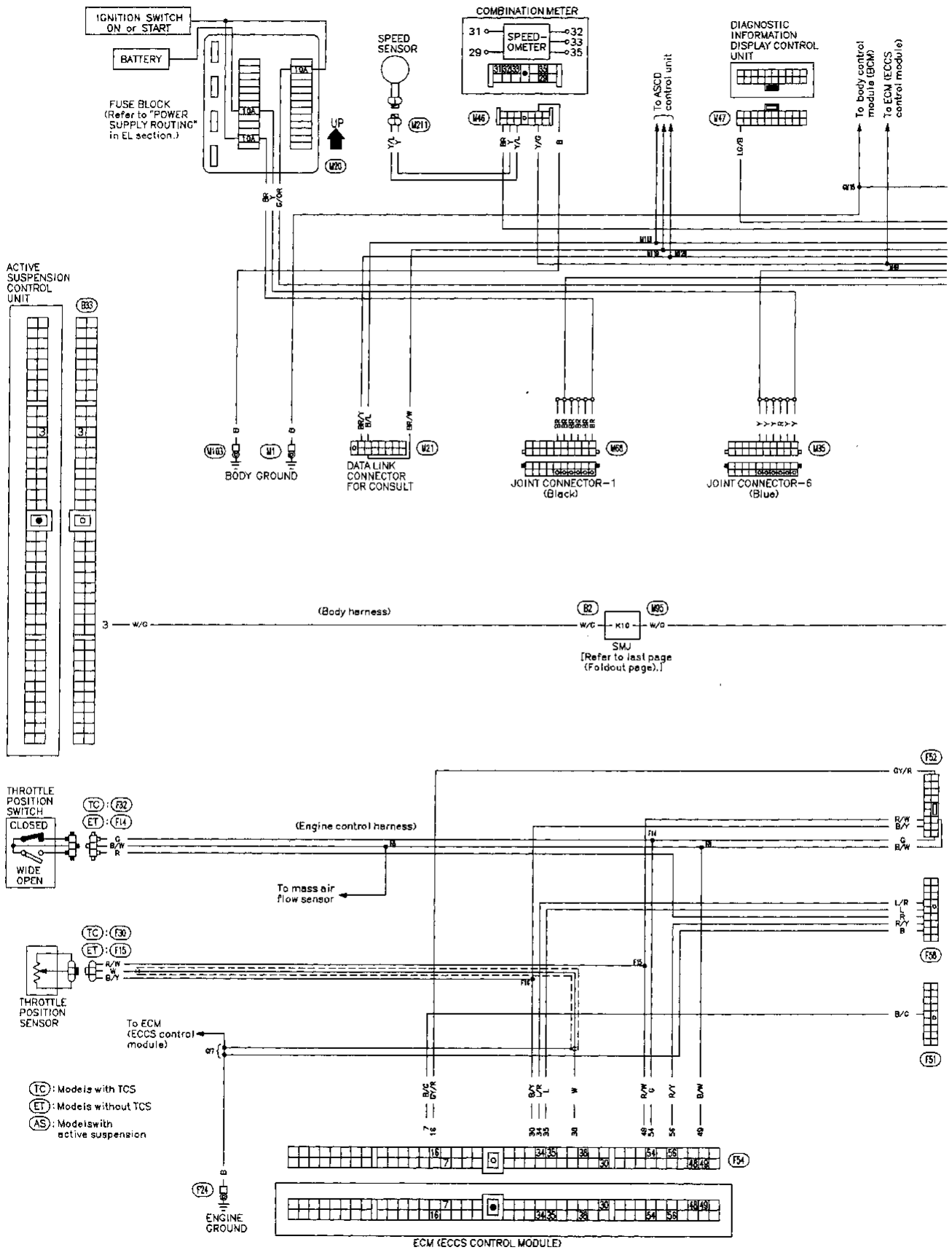

# TROUBLE DIAGNOSES

## Wiring Diagram (Cont'd)

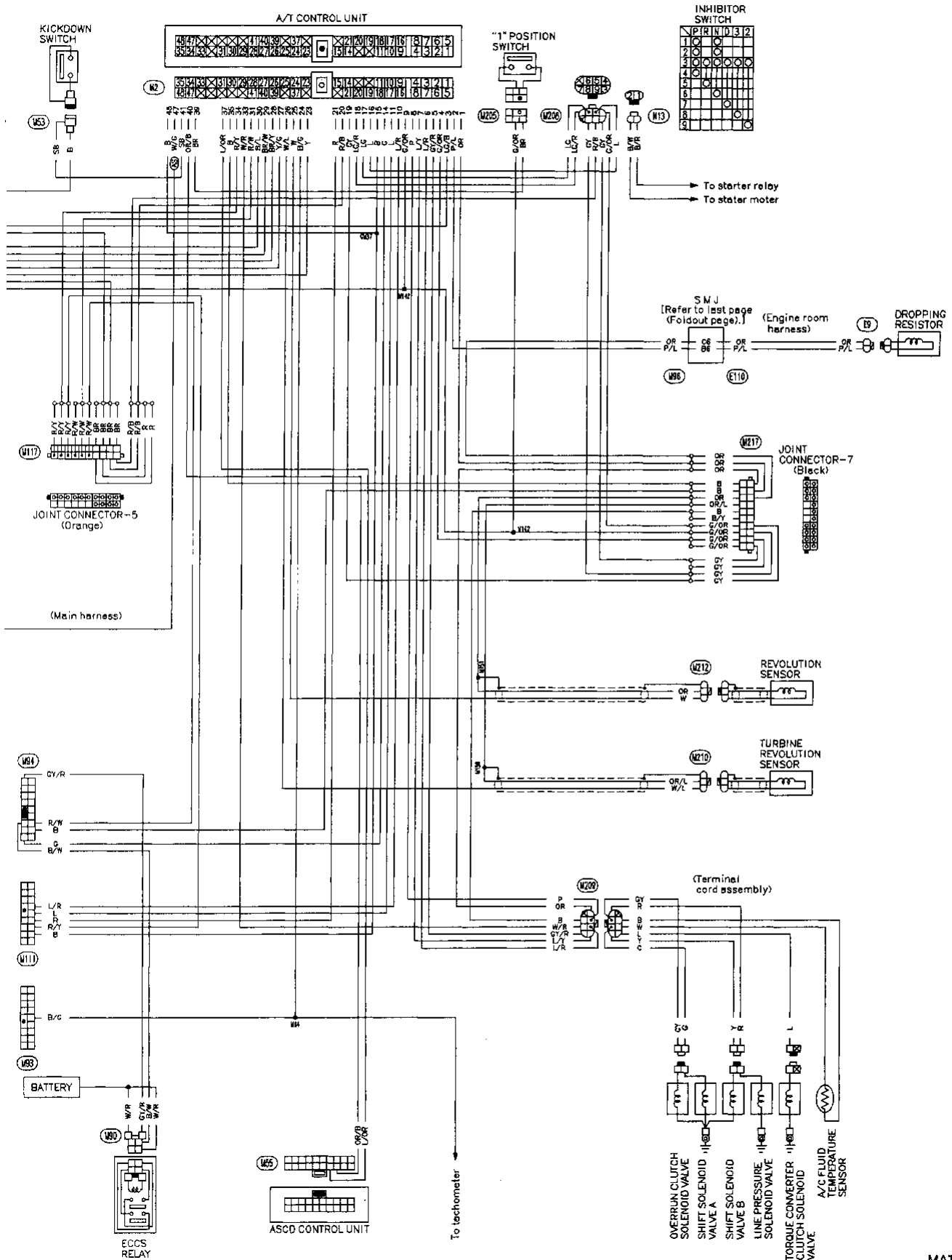

GI  
MA  
EM  
LC  
EF &  
EC  
FE  
AT  
PD  
FA  
RA  
BR  
ST  
RS  
BT  
HA  
EL  
IDX

# TROUBLE DIAGNOSES

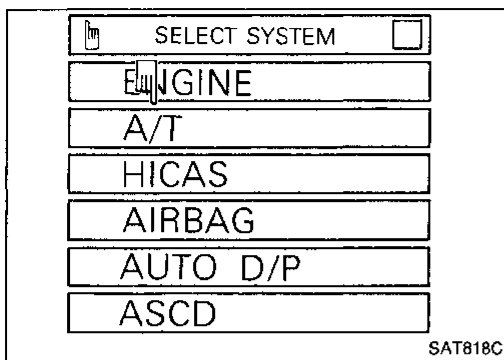

## Self-diagnosis

### SELF-DIAGNOSTIC PROCEDURE (CONSULT With CONSULT)

1. Turn on CONSULT.
2. Touch "A/T".

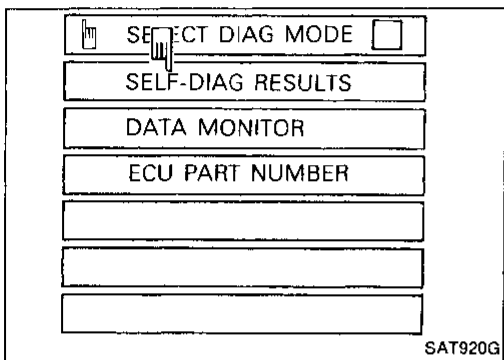

3. Touch "SELF-DIAG RESULTS".

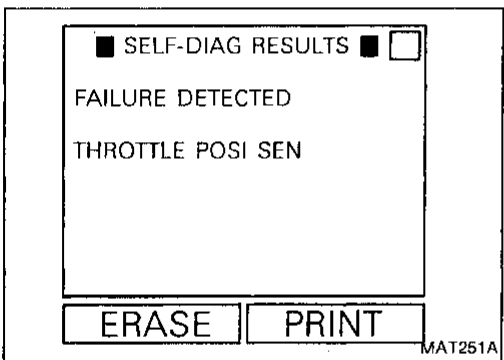

CONSULT performs REAL-TIME SELF-DIAGNOSIS.



# TROUBLE DIAGNOSES

## Self-diagnosis (Cont'd)

### SELF-DIAGNOSTIC PROCEDURE (ⓧ Without CONSULT)

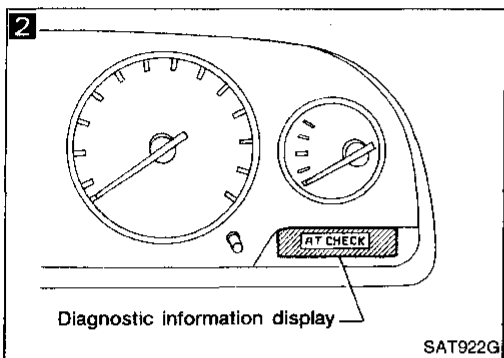
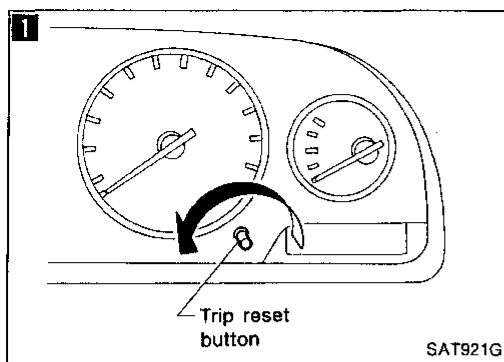

DIAGNOSIS START

1 2

1. Start engine and warm it up to normal engine operating temperature.
2. Turn ignition switch to "OFF" position.
3. Move selector lever to "D" position. (Use the shift lock release knob.)
4. Turn trip reset button counterclockwise and hold it.
5. Turn ignition switch to "ON" position. (Do not start engine.)
6. Does diagnostic information display change to A/T diagnoses mode?

No → Check diagnostic information system — Refer to EL section (DIAGNOSTIC INFORMATION DISPLAY).

Yes

1. Move selector lever to "3" position.
2. Depress accelerator pedal fully and release it.
3. Move selector lever to "2" position.
4. Move selector lever to "1" position.
5. Depress accelerator pedal fully and release it.
6. Check diagnostic information display. Refer to JUDGMENT OF SELF-DIAGNOSIS CODE on next page.

DIAGNOSIS END

GI

MA

EM

LC

EF &  
EC

FE

AT

PD

FA

RA

BR

ST

RS

BT

HA



EL

IDX

# TROUBLE DIAGNOSES



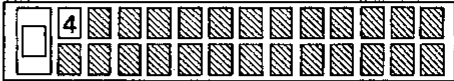
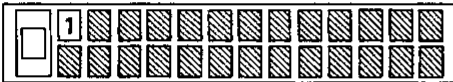
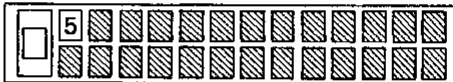
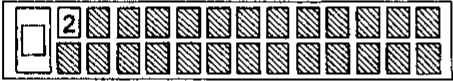
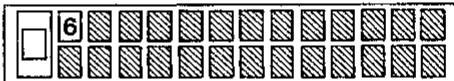

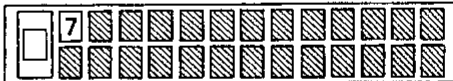

## Self-diagnosis (Cont'd)

### JUDGMENT OF SELF-DIAGNOSIS CODE

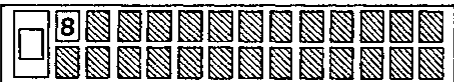
Diagnostic information display	Damaged circuit
<p style="text-align: center;">The judgment is "OK".</p> <div style="text-align: center;">  </div> <p>Indicator lamp Indicator lamp blinks when the judgment display comes on.</p> <p>All circuits that can be confirmed by self-diagnosis are OK. SAT923G</p>	<p style="text-align: center;">The judgment is "4".</p> <div style="text-align: center;">  </div> <p>Shift solenoid valve A circuit is short-circuited or disconnected. ➡ <b>Go to shift solenoid valve A circuit check.</b> SAT436G</p>
<p style="text-align: center;">The judgment is "1".</p> <div style="text-align: center;">  </div> <p>Revolution sensor circuit is short-circuited or disconnected. ➡ <b>Go to revolution sensor circuit check.</b> SAT433G</p>	<p style="text-align: center;">The judgment is "5".</p> <div style="text-align: center;">  </div> <p>Shift solenoid valve B circuit is short-circuited or disconnected. ➡ <b>Go to shift solenoid valve B circuit check.</b> SAT437G</p>
<p style="text-align: center;">The judgment is "2".</p> <div style="text-align: center;">  </div> <p>Vehicle speed sensor circuit is short-circuited or disconnected. ➡ <b>Go to vehicle speed sensor circuit check.</b> SAT006H</p>	<p style="text-align: center;">The judgment is "6".</p> <div style="text-align: center;">  </div> <p>Overrun clutch solenoid valve circuit is short-circuited or disconnected. ➡ <b>Go to overrun clutch solenoid valve circuit check.</b> SAT438G</p>
<p style="text-align: center;">The judgment is "3".</p> <div style="text-align: center;">  </div> <p>Throttle position sensor circuit is short-circuited or disconnected. ➡ <b>Go to throttle position sensor circuit check.</b> SAT435G</p>	<p style="text-align: center;">The judgment is "7".</p> <div style="text-align: center;">  </div> <p>Torque converter clutch solenoid valve circuit is short-circuited or disconnected. ➡ <b>Go to torque converter clutch solenoid valve circuit check.</b> SAT439G</p>

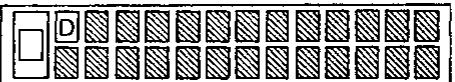
# TROUBLE DIAGNOSES

## Self-diagnosis (Cont'd)

Diagnostic information display	Damaged circuit
<p style="text-align: center;">The judgment is "8".</p> <div style="text-align: center;">  </div> <p>Fluid temperature sensor is disconnected or A/T control unit power source circuit is damaged.  <b>➡ Go to fluid temperature sensor and A/T control unit power source circuit check.</b></p> <p style="text-align: right;">SAT440G</p>	<p style="text-align: center;">The judgment is "C".</p> <div style="text-align: center;">  </div> <p>Engine control circuit between A/T control unit and ECM (ECCS control module) is short-circuited or disconnected.  <b>➡ Go to engine control circuit check.</b></p> <p style="text-align: right;">SAT444G</p>
<p style="text-align: center;">The judgment is "9".</p> <div style="text-align: center;">  </div> <p>Engine speed signal circuit is short-circuited or disconnected.  <b>➡ Go to engine speed signal circuit check.</b></p> <p style="text-align: right;">SAT441G</p>	<p style="text-align: center;">The judgment is "D".</p> <div style="text-align: center;">  </div> <p>Battery power is low.                      Battery has been disconnected for a long time.                      Battery is connected conversely.                      (When reconnecting A/T control unit connectors, this is not a problem.)</p> <p style="text-align: right;">SAT445G</p>
<p style="text-align: center;">The judgment is "A".</p> <div style="text-align: center;">  </div> <p>Turbine revolution sensor circuit is short-circuited or disconnected.  <b>➡ Go to turbine revolution sensor circuit check.</b></p> <p style="text-align: right;">SAT442G</p>	<p style="text-align: center;">The judgment is "AT CHECK".</p> <div style="text-align: center;">  </div> <p>Inhibitor switch, 1 position switch, kickdown switch, closed throttle position switch or diagnostic information display system circuit is disconnected, or A/T control unit is damaged.  <b>➡ Go to Inhibitor switch, 1 position switch, kickdown switch, closed throttle position switch, diagnostic information display system circuit checks.</b></p> <p style="text-align: right;">SAT446G</p>
<p style="text-align: center;">The judgment is "B".</p> <div style="text-align: center;">  </div> <p>Line pressure solenoid valve circuit is short-circuited or disconnected.  <b>➡ Go to line pressure solenoid valve circuit check.</b></p> <p style="text-align: right;">SAT443G</p>	

GI

MA

EM

LC

EF &  
EC

FE

AT

PD

FA

RA

BR

ST

RS

BT

HA

EL

IDX

# TROUBLE DIAGNOSES

## Self-diagnosis (Cont'd)

### REVOLUTION SENSOR CIRCUIT CHECK

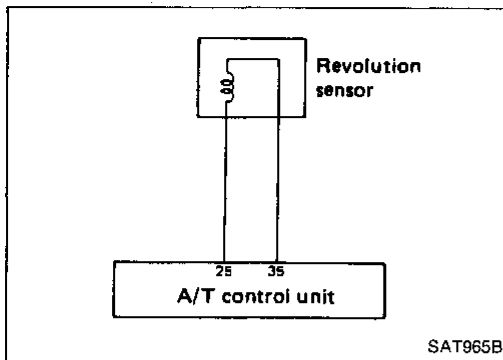

**A**

☆MONITOR	☆NO FAIL	
VHCL/S SE·A/T	0km/h	
VHCL/S SE·MTR	5km/h	
THRTL POS SEN	0.5V	
FLUID TEMP SE	1.4V	
BATTERY VOLT	10.6V	
ENGINE SPEED	256rpm	
TURBINE REV	288rpm	
SLCT LEVER SW	O N	
R POSITION SW	OFF	

**RECORD**

SAT448G

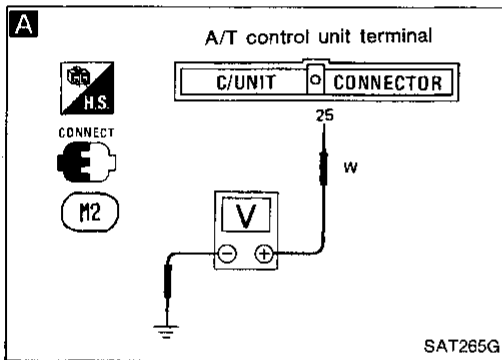

**CHECK REVOLUTION SENSOR.** — Refer to "Electrical Components Inspection", AT-75.

NG → Repair or replace revolution sensor.

OK

**A**

#### CHECK INPUT SIGNAL.

1. Turn ignition switch to "START" position and start engine.

- 2.
- Select "ECU INPUT SIGNALS".
  - Touch "START".
  - Read out the value of "VHCL/S SE·A/T" while driving.
  - Check the value changes according to driving speed.

NG → Check harness continuity between A/T control unit and revolution sensor.



Check voltage between A/T control unit terminal 25 and ground while driving.

(Measure with AC position.)

#### Voltage:

At 0 km/h (0 MPH):

0V

At 30 km/h (19 MPH):

1V or more

(Voltage rises gradually in response to vehicle speed.)

OK

Perform self-diagnosis again after driving for a while.

NG →

1. Perform A/T control unit input/output signal inspection.
2. If NG, recheck A/T control unit pin terminals for damage or loose connection with harness connector.

OK

**INSPECTION END**

# TROUBLE DIAGNOSES

## Self-diagnosis (Cont'd)

### VEHICLE SPEED SENSOR CIRCUIT CHECK

<b>A</b>	☆MONITOR ☆NO FAIL	
	VHCL/S SE-A/T	0km/h
	VHCL/S SE-MTR	5km/h
	THRTL POS SEN	0.5V
	FLUID TEMP SE	1.4V
	BATTERY VOLT	10.6V
	ENGINE SPEED	256rpm
	TURBINE REV	288rpm
	SLCT LEVER SW	O N
	R POSITION SW	OFF
<b>RECORD</b>		

SAT448G

**A**

**CHECK INPUT SIGNAL.**

- Turn ignition switch to "START" position and start engine.
- Select "ECU INPUT SIGNALS".
  - Touch "START".
  - Read out the value of "VHCL/S SE-MTR" while driving.
  - Check the value changes according to driving speed.

OR

- Check voltage between A/T control unit terminal 27 and ground while driving at 2 to 3 km/h (1 to 2 MPH) for 1 m (3 ft) or more.

**Voltage: Varies from 0V to 5V**

NG

Check the following items.

- Vehicle speed sensor and ground circuit for vehicle speed sensor — Refer to EL section (Inspection/Vehicle Speed Sensor Signal Circuit).
- Harness continuity between A/T control unit and vehicle speed sensor

OK

Perform self-diagnosis again after driving for a while.

OK

**INSPECTION END**

NG

- Perform A/T control unit input/output signal inspection.
- If NG, recheck A/T control unit pin terminals for damage or loose connection with harness connector.

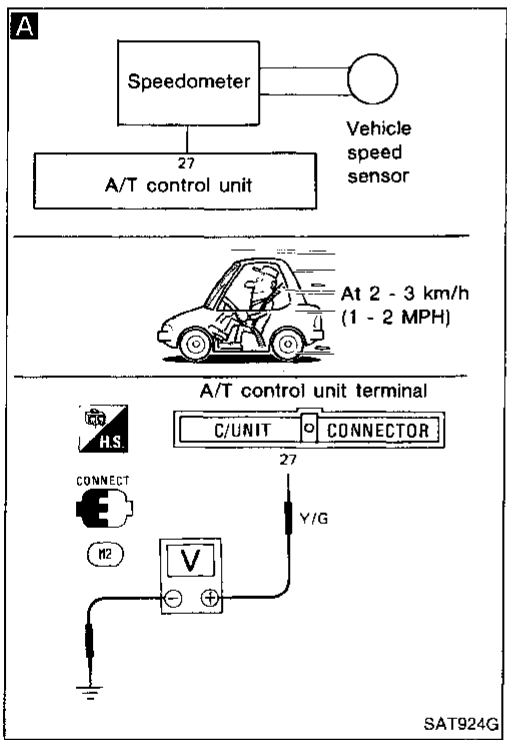

GI  
MA  
EM  
LC  
EF & EC  
FE  
AT  
PD  
FA  
RA  
BR  
ST  
RS  
BT  
HA  
EL  
IDX

# TROUBLE DIAGNOSES

## Self-diagnosis (Cont'd)

### THROTTLE POSITION SENSOR CIRCUIT CHECK

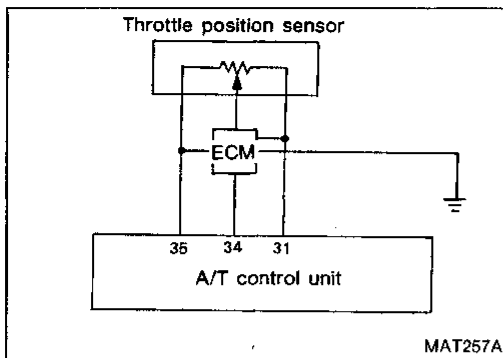

**A**

☆MONITOR	☆NO FAIL	<input type="checkbox"/>
VHCL/S SE•A/T	0km/h	
VHCL/S SE•MTR	5km/h	
THRTL POS SEN	0.5V	
FLUID TEMP SE	1.4V	
BATTERY VOLT	11.2V	
ENGINE SPEED	250rpm	
TURBINE REV	288rpm	
SLCT LEVER SW	O N	
R POSITION SW	OFF	

**RECORD**

SAT450G

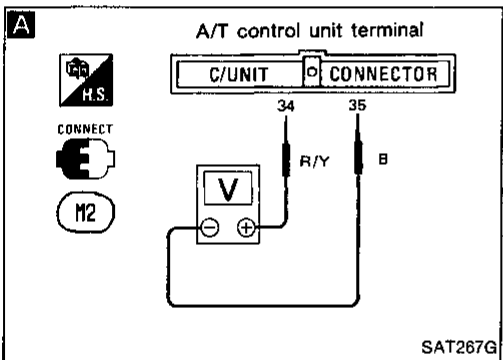

Perform self-diagnosis (Mode II) for engine control. Refer to EF & EC section (TROUBLE DIAGNOSES, On-board Diagnostic System).

NG → Check throttle position sensor circuit for engine control. — Refer to EF & EC section (TROUBLE DIAGNOSES, Diagnostic Procedure 13).

OK

**A** CHECK INPUT SIGNAL.

1. Turn ignition switch to "ON" position. (Do not start engine.)

2.

- Select "ECU INPUT SIGNALS".
- Touch "START".
- Read out the value of "THRTL POS SEN".

**Voltage:**

**Fully-closed throttle:**

**Approximately 0.5V**

**Fully-open throttle:**

**Approximately 4V**

OR

- Check voltage between A/T control unit terminals 34 and 35 while accelerator pedal is depressed slowly.

**Voltage:**

**Fully-closed throttle:**

**Approximately 0.5V**

**Fully-open throttle:**

**Approximately 4V**

(Voltage rises gradually in response to throttle valve opening.)

NG → Check harness continuity between ECM and A/T control unit regarding throttle position sensor circuit.

OK

Perform self-diagnosis again after driving for a while.

NG → 1. Perform A/T control unit input/output signal inspection.  
2. If NG, recheck A/T control unit pin terminals for damage or loose connection with harness connector.

OK

**INSPECTION END**

# TROUBLE DIAGNOSES

## Self-diagnosis (Cont'd)

### SHIFT SOLENOID VALVE A CIRCUIT CHECK

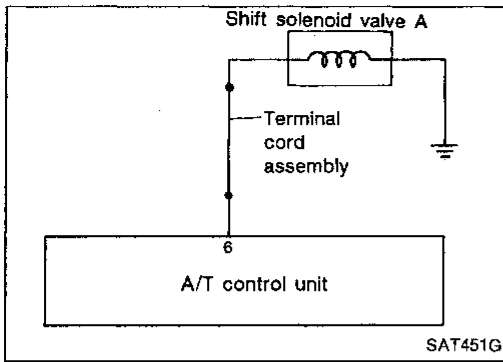

**A**

#### CHECK GROUND CIRCUIT.

1. Turn ignition switch to "OFF" position.
2. Disconnect terminal cord assembly connector at the end of A/T assembly.
3. Check resistance between terminal ⑥ and ground.

**Resistance: 20 - 40Ω**

NG

1. Remove control valve assembly. — Refer to "ON-VEHICLE SERVICE", AT-106.
2. Check the following items.
  - Shift solenoid valve A — Refer to "Electrical Components Inspection", AT-75.
  - Harness continuity of terminal cord assembly

OK

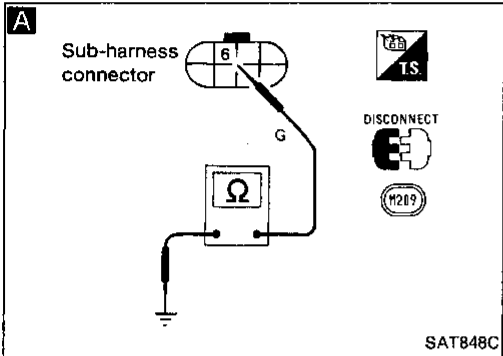

**B**

#### CHECK POWER SOURCE CIRCUIT.

1. Turn ignition switch to "OFF" position.
2. Disconnect A/T control unit connector.
3. Check resistance between terminal ⑥ and A/T control unit terminal ⑥.

**Resistance: Approximately 0Ω**

NG

- Repair or replace harness between A/T control unit and terminal cord assembly.

OK

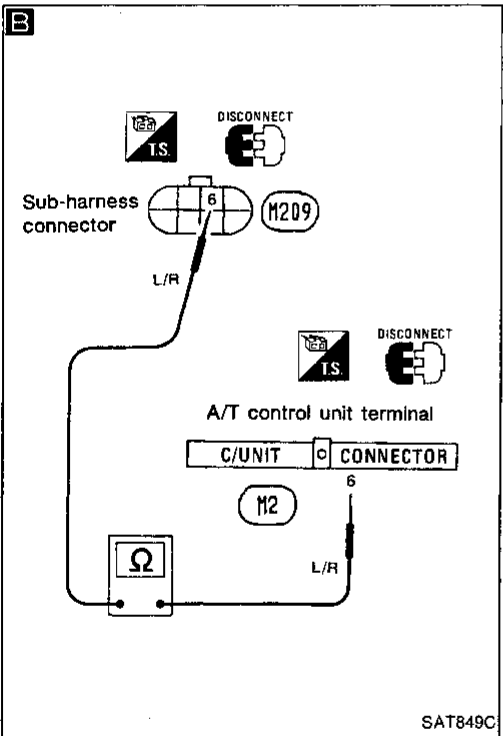

Perform self-diagnosis after driving for a while.

NG

1. Perform A/T control unit input/output signal inspection.
2. If NG, recheck A/T control unit pin terminals for damage or loose connection with harness connector.

OK

**INSPECTION END**

GI  
MA  
EM  
LC  
EF & EC  
FE  
AT  
PD  
FA  
RA  
BR  
ST  
RS  
BT  
HA  
EL  
IDX

# TROUBLE DIAGNOSES

## Self-diagnosis (Cont'd)

### SHIFT SOLENOID VALVE B CIRCUIT CHECK

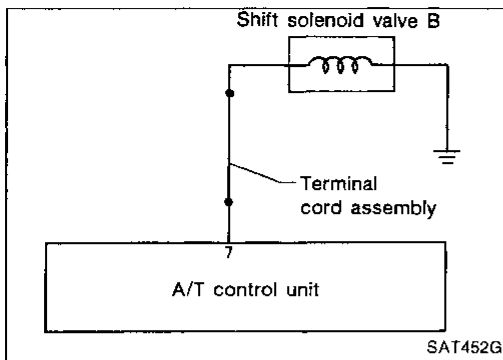

**A**

**CHECK GROUND CIRCUIT.**

1. Turn ignition switch to "OFF" position.
2. Disconnect terminal cord assembly connector at the end of A/T assembly.
3. Check resistance between terminal ⑦ and ground.

**Resistance: 20 - 40Ω**

NG

1. Remove control valve assembly. — Refer to "ON-VEHICLE SERVICE", AT-106.
2. Check the following items.
  - Shift solenoid valve B — Refer to "Electrical Components Inspection", AT-75.
  - Harness continuity of terminal cord assembly

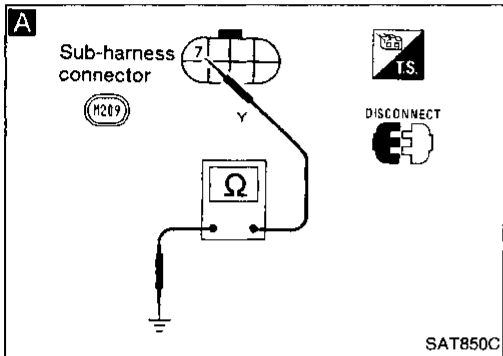

OK

**B**

**CHECK POWER SOURCE CIRCUIT.**

1. Turn ignition switch to "OFF" position.
2. Disconnect A/T control unit connector.
3. Check resistance between terminal ⑦ and A/T control unit terminal ⑦.

**Resistance: Approximately 0Ω**

4. Reinstall any part removed.

NG

Repair or replace harness between A/T control unit and terminal cord assembly.

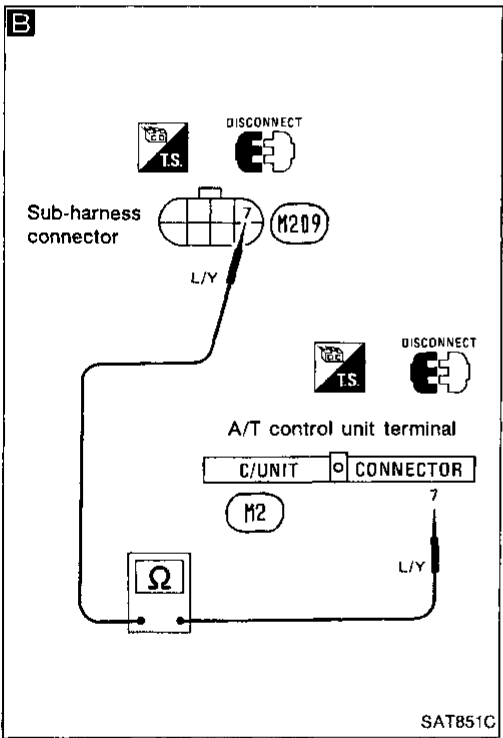

OK

Perform self-diagnosis after driving for a while.

OK

**INSPECTION END**

NG

1. Perform A/T control unit input/output signal inspection.
2. If NG, recheck A/T control unit pin terminals for damage or loose connection with harness connector.



# TROUBLE DIAGNOSES

## Self-diagnosis (Cont'd)

### OVERRUN CLUTCH SOLENOID VALVE CIRCUIT CHECK

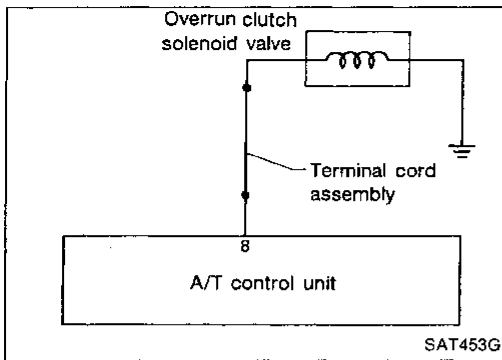

**A**

#### CHECK GROUND CIRCUIT.

1. Turn ignition switch to "OFF" position.
2. Disconnect terminal cord assembly connector at the end of A/T assembly.
3. Check resistance between terminal ⑧ and ground.

**Resistance: 20 - 40Ω**

NG

1. Remove control valve assembly. — Refer to "ON-VEHICLE SERVICE", AT-106.
2. Check the following items.
  - Overrun clutch solenoid valve — Refer to "Electrical Components Inspection", AT-75.
  - Harness continuity of terminal cord assembly

OK

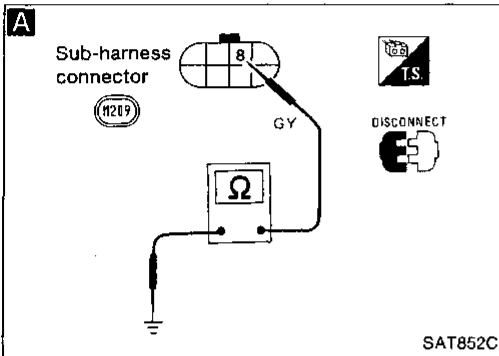

**B**

#### CHECK POWER SOURCE CIRCUIT.

1. Turn ignition switch to "OFF" position.
2. Disconnect A/T control unit connector.
3. Check resistance between terminal ⑧ and A/T control unit terminal ⑧.

**Resistance: Approximately 0Ω**

NG

- Repair or replace harness between A/T control unit and terminal cord assembly.

OK

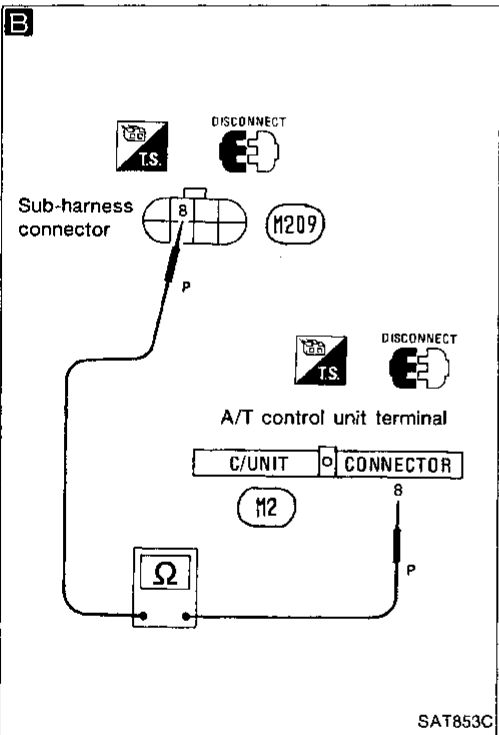

Perform self-diagnosis after driving for a while.

NG

1. Perform A/T control unit input/output signal inspection.
2. If NG, recheck A/T control unit pin terminals for damage or loose connection with harness connector.

OK

**INSPECTION END**

GI  
MA  
EM  
LC  
EF & EC  
FE  
AT  
PD  
FA  
RA  
BR  
ST  
RS  
BT  
HA  
EL  
IDX

# TROUBLE DIAGNOSES

## Self-diagnosis (Cont'd)

### TORQUE CONVERTER CLUTCH SOLENOID VALVE CIRCUIT CHECK

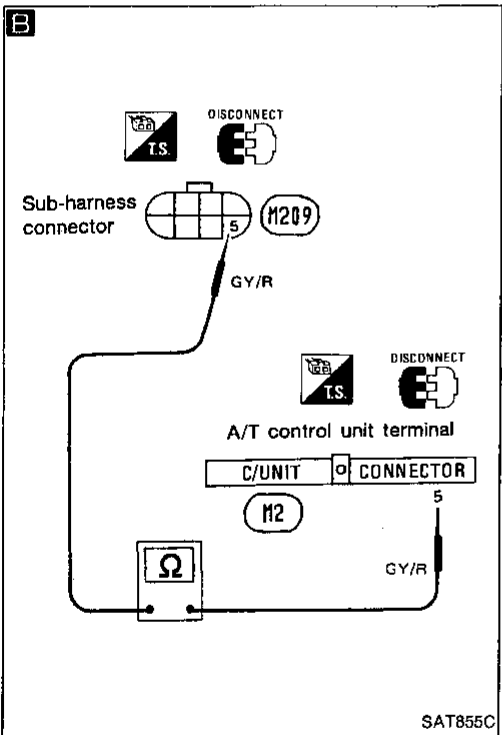
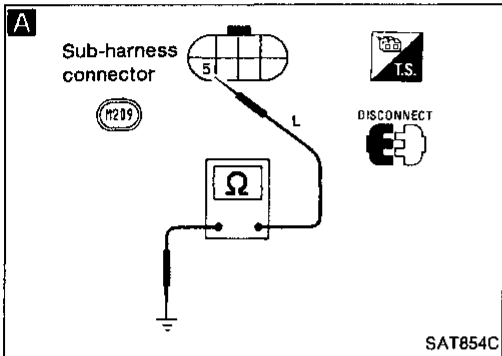
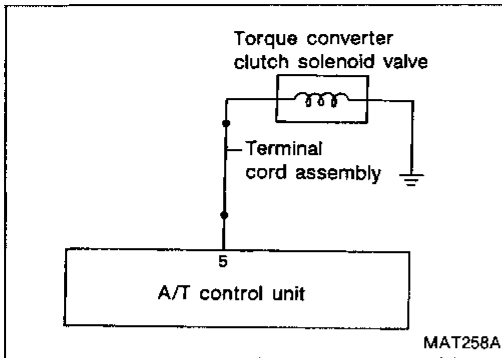

**A**

#### CHECK GROUND CIRCUIT.

1. Turn ignition switch to "OFF" position.
2. Disconnect terminal cord assembly connector at the end of A/T assembly.
3. Check resistance between terminal ⑤ and ground.

**Resistance: 10 - 20Ω**

NG

1. Remove oil pan. — Refer to "ON-VEHICLE SERVICE", AT-106.
2. Check the following items.
  - Torque converter clutch solenoid valve. — Refer to "Electrical Components Inspection", AT-75.
  - Harness continuity of terminal cord assembly

OK

**B**

#### CHECK POWER SOURCE CIRCUIT.

1. Turn ignition switch to "OFF" position.
2. Disconnect A/T control unit connector.
3. Check resistance between terminal ⑤ and A/T control unit terminal ⑤.

**Resistance: Approximately 0Ω**

4. Reinstall any part removed.

NG

- Repair or replace harness between A/T control unit and terminal cord assembly.

OK

Perform self-diagnosis after driving for a while.

NG

1. Perform A/T control unit input/output signal inspection.
2. If NG, recheck A/T control unit pin terminals for damage or loose connection with harness connector.

OK

**INSPECTION END**

# TROUBLE DIAGNOSES

## Self-diagnosis (Cont'd)

### FLUID TEMPERATURE SENSOR CIRCUIT AND A/T CONTROL UNIT POWER SOURCE CIRCUIT CHECKS

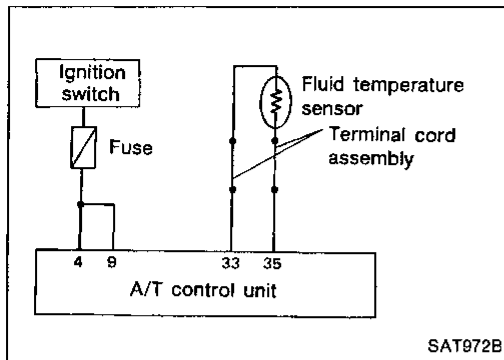

**A**

**CHECK A/T CONTROL UNIT POWER SOURCE.**

1. Turn ignition switch to "ON" position. (Do not start engine.)
2. Check voltage between A/T control unit terminals ④, ⑨ and ground. **Battery voltage should exist.**

NG

Check the following items.

- Harness continuity between ignition switch and A/T control unit
- Ignition switch and fuse — Refer to EL section (STARTING SYSTEM).

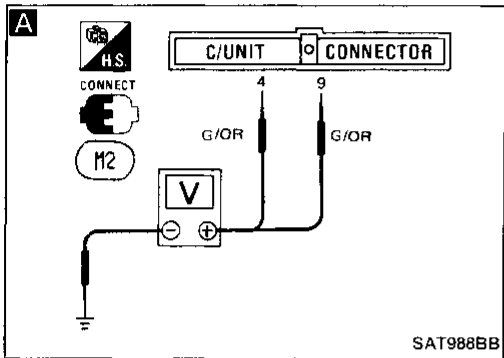

**B**

**CHECK FLUID TEMPERATURE SENSOR WITH TERMINAL CORD ASSEMBLY.**

1. Turn ignition switch to "OFF" position.
2. Disconnect terminal cord assembly connector at the end of A/T assembly.
3. Check resistance between terminals ③③ and ③⑤ when A/T is cold. **Resistance:**  
Cold [20°C (68°F)]  
Approximately 2.5 kΩ
4. Reinstall any part removed.

NG

1. Remove control valve cover.
2. Check the following items.
  - Fluid temperature sensor — Refer to "Electrical Components Inspection", AT-75.
  - Harness continuity of terminal cord assembly

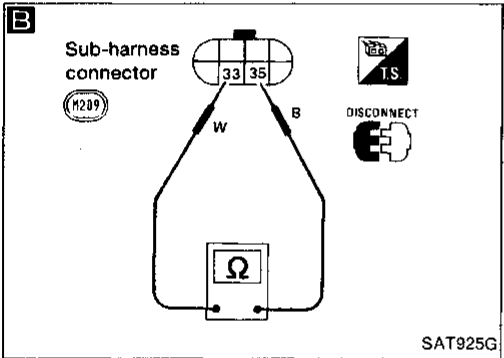

**C**

**CHECK INPUT SIGNAL OF FLUID TEMPERATURE SENSOR.**

1. Turn ignition switch to "ON" position and start engine.
2.
  - Select "ECU INPUT SIGNALS".
  - Touch "START".
  - Read out the value of "FLUID TEMP SE".**Voltage:**  
Cold [20°C (68°F)] →  
Hot [80°C (176°F)]:  
Approximately 1.5V → 0.5V

NG

Check harness continuity between A/T control unit and terminal cord assembly.

**C**

☆ MONITOR ☆ NO FAIL	
VHCL/S SE·A/T	0km/h
VHCL/S SE·MTR	5km/h
THRTL POS SEN	0.5V
FLUID TEMP SE	1.4V
BATTERY VOLT	10.6V
ENGINE SPEED	256rpm
TURBINE REV	288rpm
SLCT LEVER SW	O N
R POSITION SW	OFF

**RECORD**

SAT454G

OR

- Check voltage between A/T control unit terminal ③③ and ground while warming up A/T. **Voltage:**  
Cold [20°C (68°F)] →  
Hot [80°C (176°F)]:  
Approximately 1.5V → 0.5V

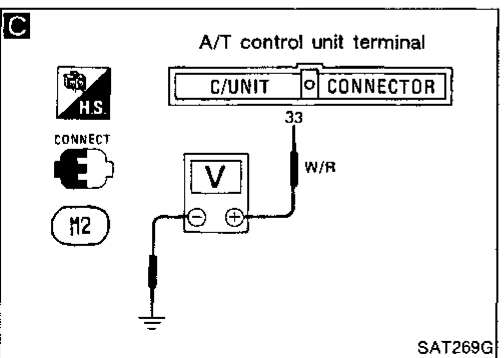

OK

Perform self-diagnosis after driving for a while.

NG

1. Perform A/T control unit input/output signal inspection.
2. If NG, recheck A/T control unit pin terminals for damage or loose connection with harness connector.

OK

**INSPECTION END**

# TROUBLE DIAGNOSES

## Self-diagnosis (Cont'd)

### ENGINE SPEED SIGNAL CIRCUIT CHECK

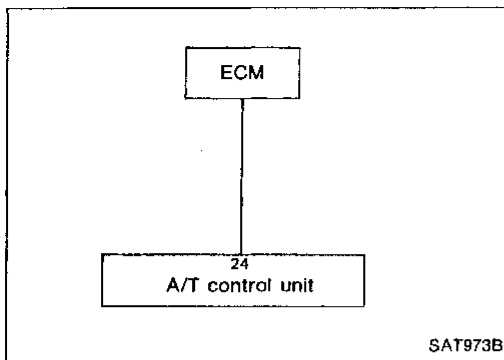

**A**

☆ MONITOR	☆ NO FAIL	<input type="checkbox"/>
VHCL/S SE·A/T	0km/h	
VHCL/S SE·MTR	5km/h	
THRTL POS SEN	0.5V	
FLUID TEMP SE	1.4V	
BATTERY VOLT	11.2V	
ENGINE SPEED	256rpm	
TURBINE REV	288rpm	
SLCT LEVER SW	O N	
R POSITION SW	OFF	

**RECORD**

SAT450G

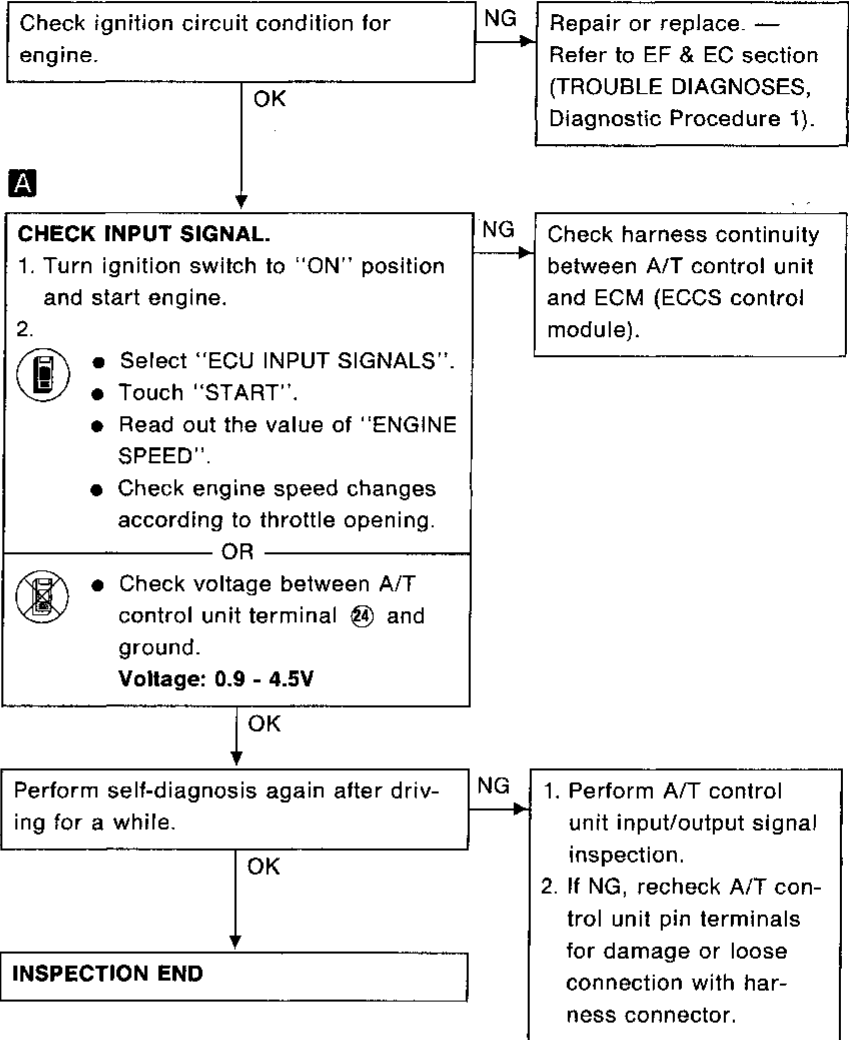
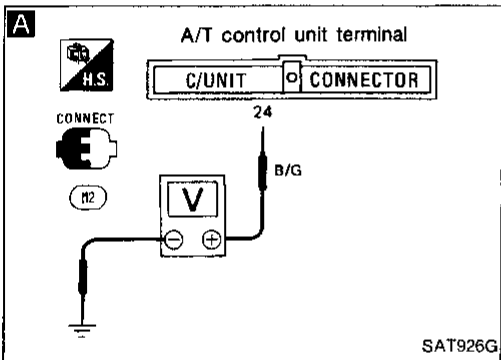

# TROUBLE DIAGNOSES

## Self-diagnosis (Cont'd)

### TURBINE REVOLUTION SENSOR CIRCUIT CHECK

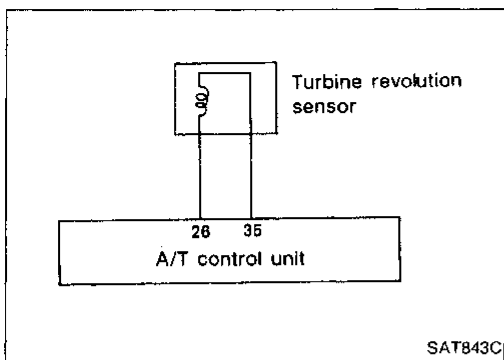

**A**

☆ MONITOR	☆ NO FAIL	<input type="checkbox"/>
VHCL/S SE·A/T	0km/h	
VHCL/S SE·MTR	5km/h	
THRTL POS SEN	0.5V	
FLUID TEMP SE	1.4V	
BATTERY VOLT	11.2V	
ENGINE SPEED	256rpm	
TURBINE REV	288rpm	
SLCT LEVER SW	O N	
R POSITION SW	OFF	

**RECORD**

SAT450G

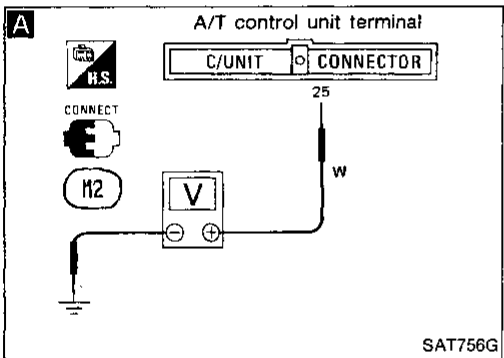

**CHECK TURBINE REVOLUTION SENSOR.** — Refer to "Electrical Components Inspection", AT-75.

NG → Repair or replace turbine revolution sensor.

OK

**A**

**CHECK INPUT SIGNAL.**

1. Turn ignition switch to "START" position and start engine.

2.

- Select "ECU INPUT SIGNALS".
- Touch "START".
- Read out the value of "TURBINE REV".
- Check the value changes according to engine speed.

OR

● Check voltage between A/T control unit terminal 25 and ground. (Measure with AC position.)

**Voltage: 0.3 - 4.5V**

NG → Check harness continuity between A/T control unit and turbine revolution sensor.

OK

Perform self-diagnosis again after driving for a while.

NG → 1. Perform A/T control unit input/output signal inspection.

OK

2. If NG, recheck A/T control unit pin terminals for damage or loose connection with harness connector.

**INSPECTION END**

GI

MA

EM

LC

EF & EC

FE

**AT**

PD

FA

RA

BR

ST

RS

BT

HA

EL

DX

# TROUBLE DIAGNOSES

## Self-diagnosis (Cont'd)

### LINE PRESSURE SOLENOID VALVE CIRCUIT CHECK

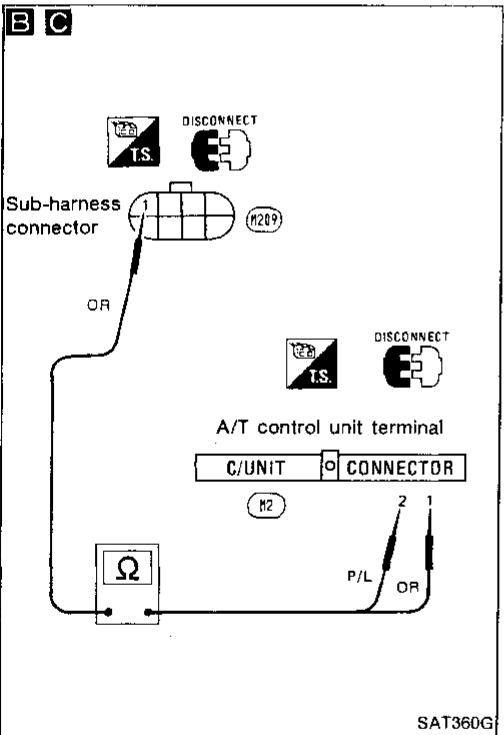
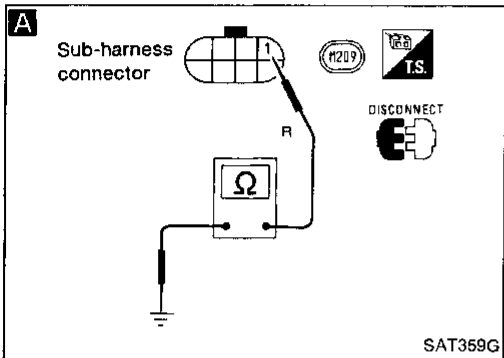
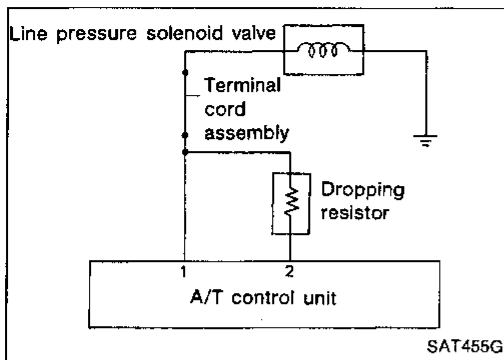

**A**

**CHECK GROUND CIRCUIT.**

1. Turn ignition switch to "OFF" position.
2. Disconnect terminal cord assembly connector at the end of A/T assembly.
3. Check resistance between terminal ① and ground.

**Resistance: 2.5 - 5Ω**

NG

1. Remove control valve assembly. — Refer to "ON-VEHICLE SERVICE", AT-106.
2. Check the following items.
  - Line pressure solenoid valve — Refer to "Electrical Components Inspection", AT-75.
  - Harness continuity of terminal cord assembly

**B**

**CHECK POWER SOURCE CIRCUIT.**

1. Turn ignition switch to "OFF" position.
2. Disconnect A/T control unit connector.
3. Check resistance between terminal ① and A/T control unit terminal ②.

**Resistance: 11.2 - 12.8Ω**

NG

Check the following items.

- Dropping resistor — Refer to "Electrical Components Inspection", AT-75.
- Harness continuity between A/T control unit ② and terminal cord assembly

**C**

**CHECK POWER SOURCE CIRCUIT.**

1. Turn ignition switch to "OFF" position.
2. Check resistance between terminal ① and A/T control unit terminal ①.

**Resistance: Approximately 0Ω**

3. Reinstall any part removed.

NG

Repair or replace harness between A/T control unit ① and terminal cord assembly.

OK

Perform self-diagnosis after driving for a while.

NG

1. Perform A/T control unit input/output signal inspection.
2. If NG, recheck A/T control unit pin terminals for damage or loose connection with harness connector.

OK

**INSPECTION END**

# TROUBLE DIAGNOSES

## Self-diagnosis (Cont'd)

### ENGINE CONTROL CIRCUIT CHECK

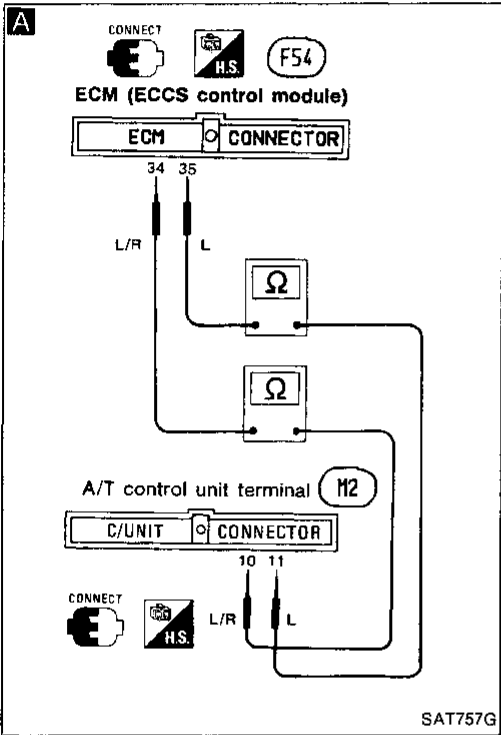
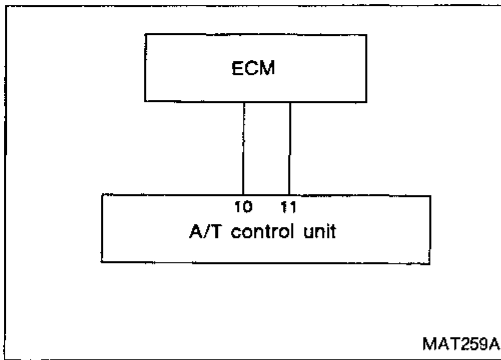

**A**

**CHECK CIRCUIT BETWEEN A/T CONTROL UNIT AND ECM (ECCS CONTROL MODULE).**

1. Turn ignition switch to "OFF" position.
2. Check continuity between A/T control unit terminal ⑩ and ECM (ECCS control module) terminal ③④.
3. Check continuity between A/T control unit terminal ⑪ and ECM (ECCS control module) terminal ③⑤.

**Continuity should exist.**

**Continuity should exist.**

NG → Repair or replace harness and connector between A/T control unit and ECM (ECCS control module).

OK

Perform self-diagnosis for engine control. — Refer to EF & EC section (TROUBLE DIAGNOSES, On-board Diagnostic System).

NG → Check ECM (ECCS control module) — Refer to EF & EC section (TROUBLE DIAGNOSES, Diagnostic Procedure 8).

OK

Perform self-diagnosis again after driving for a while.

NG → If NG, recheck A/T control unit pin terminals for damage or loose connection with harness connector.

OK

**INSPECTION END**

GI

MA

EM

LC

EF & EC

FE

**AT**

PD

FA

RA

BR

ST

RS

BT

HA

EL

IDX

# TROUBLE DIAGNOSES

## Self-diagnosis (Cont'd)

### INHIBITOR SWITCH, 1 POSITION SWITCH, KICKDOWN SWITCH, CLOSED THROTTLE POSITION SWITCH AND DIAGNOSTIC INFORMATION DISPLAY CIRCUIT CHECKS

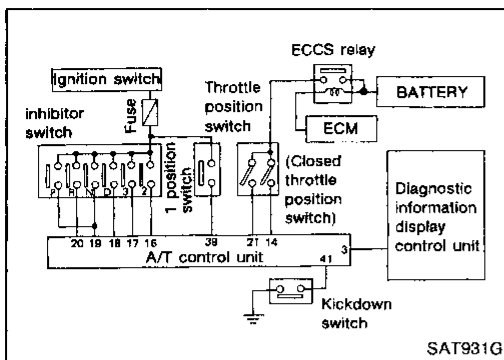

SAT931G

**A**

☆ MONITOR	☆ NO FAIL	
P/N POSI SW	O N	
R POSITION SW	OFF	
D POSITION SW	OFF	
4 POSITION SW	OFF	
3 POSITION SW	OFF	
2 POSITION SW	OFF	
1 POSITION SW	OFF	
ASCD•CRUISE	OFF	
ASCD•OD CUT	OFF	

**RECORD**

SAT919G

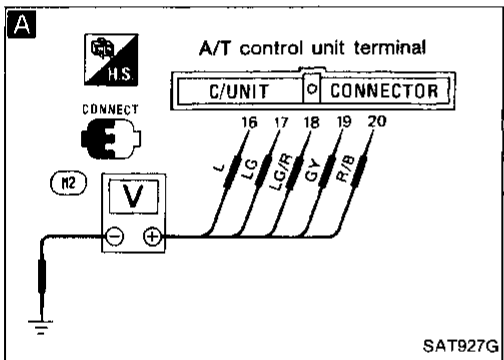

SAT927G

**B**

☆ MONITOR	☆ NO FAIL	
P/N POSI SW	OFF	
R POSITION SW	OFF	
D POSITION SW	OFF	
4 POSITION SW	OFF	
3 POSITION SW	OFF	
2 POSITION SW	O N	
1 POSITION SW	O N	
ASCD•CRUISE	OFF	
ASCD•OD CUT	OFF	

**RECORD**

SAT928G

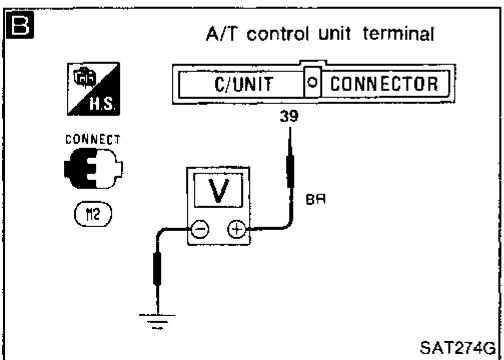

SAT274G

**A**

**CHECK INHIBITOR SWITCH CIRCUIT.**

- Turn ignition switch to "ON" position. (Do not start engine.)
- Select "ECU INPUT SIGNALS".
  - Touch "START".
  - Read out "R, N, D, 2 and 3 POSITION SW" moving selector lever to each position.
  - Check the selector lever position is indicated properly.

NG → Check the following items.

- Inhibitor switch — Refer to "Electrical Components Inspection", AT-75.
- Harness continuity between ignition switch and inhibitor switch
- Harness continuity between inhibitor switch and A/T control unit

OR

Check voltage between A/T control unit terminals ⑯, ⑰, ⑱, ⑲, ⑳ and ground while moving selector lever through each position.

**Voltage:**  
**B: Battery voltage**  
**0: 0V**

Lever position	Terminal No.				
	⑯	⑲	⑱	⑰	⑯
P, N	B	0	0	0	0
R	0	B	0	0	0
D	0	0	B	0	0
3	0	0	0	B	0
2, 1	0	0	0	0	B

OK ↓

**B**

**CHECK 1 POSITION SWITCH CIRCUIT.**

- Turn ignition switch to "ON" position. (Do not start engine.)
- Select "ECU INPUT SIGNALS".
  - Touch "START".
  - Read out "1 POSITION SW" moving selector lever to 1 position.
  - Check the selector lever position is indicated properly.

OR

Check voltage between A/T control unit terminal ⑳ and ground while moving selector lever to 1 position.

**Voltage:**  
**Battery voltage**

NG → Check the following items.

- 1 position switch — Refer to "Electrical Components Inspection", AT-75
- Harness continuity between ignition switch and 1 position switch
- Harness continuity between 1 position switch and A/T control unit

OK ↓

**A**



# TROUBLE DIAGNOSES

## Self-diagnosis (Cont'd)

**C**

☆ MONITOR ☆ NO FAIL

KICKDOWN SW	ON
POWER SHIFT SW	OFF
CLOSED THL/SW	OFF
W/O THL/P-SW	OFF
HOLD SW	OFF

RECORD

SAT929G

**C**

**CHECK KICKDOWN SWITCH CIRCUIT.**

- Turn ignition switch to "ON" position. (Do not start engine.)
- Select "ECU INPUT SIGNALS".
  - Touch "START".
  - Read out "KICKDOWN SW" depressing accelerator pedal fully.
  - Check kickdown switch position is indicated properly.

OR

- Check voltage between A/T control unit terminal ④ and ground while depressing accelerator pedal slowly. (after warming up engine)

**Voltage:**

**When releasing accelerator pedal:**  
3 - 8V

**When depressing accelerator pedal fully:**  
1 V or less

NG

Check the following items.

- Kickdown switch
- Harness continuity between A/T control unit and kickdown switch
- Harness continuity of ground circuit for kickdown switch

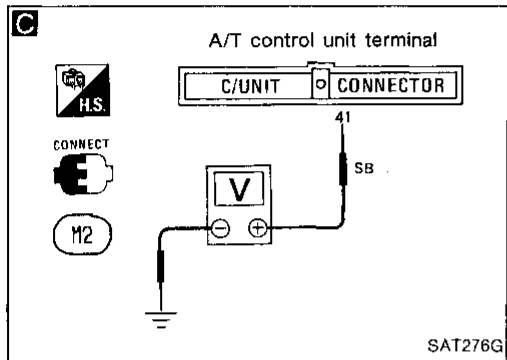

**D**

☆ MONITOR ☆ NO FAIL

KICKDOWN SW	OFF
POWER SHIFT SW	OFF
CLOSED THL/SW	ON
W/O THL/P-SW	OFF
HOLD SW	OFF

RECORD

SAT930G

**D**

**CHECK CLOSED THROTTLE POSITION SWITCH CIRCUIT.**

- Turn ignition switch to "ON" position. (Do not start engine.)
- Select "ECU INPUT SIGNALS".
  - Touch "START".
  - Read out "CLOSED THL/SW" depressing and releasing accelerator pedal.
  - Check closed throttle position switch changes ON or OFF.

OR

- Check voltage between A/T control unit terminal ⑭ and ground while depressing accelerator pedal slowly.

**Voltage:**

**When releasing accelerator pedal:**  
8 - 15V

**When depressing accelerator pedal fully:**  
1 V or less

NG

Perform self-diagnosis (Mode II) for engine control. Refer to EF & EC section (TROUBLE DIAGNOSES, On-board Diagnostic System). Check closed throttle position switch circuit.

OK

Check harness continuity between A/T control unit and closed throttle position switch.

NG

Check closed throttle position switch circuit for engine control. — Refer to EF & EC section (TROUBLE DIAGNOSES, Diagnostic Procedure 24).

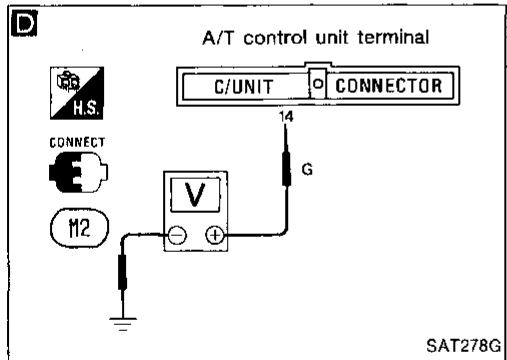

OK

⑧

GI  
MA  
EM  
LC  
EF & EC  
FE  
AT  
PD  
FA  
RA  
BR  
ST  
RS  
BT  
HA  
EL  
IDX

# TROUBLE DIAGNOSES

## Self-diagnosis (Cont'd)

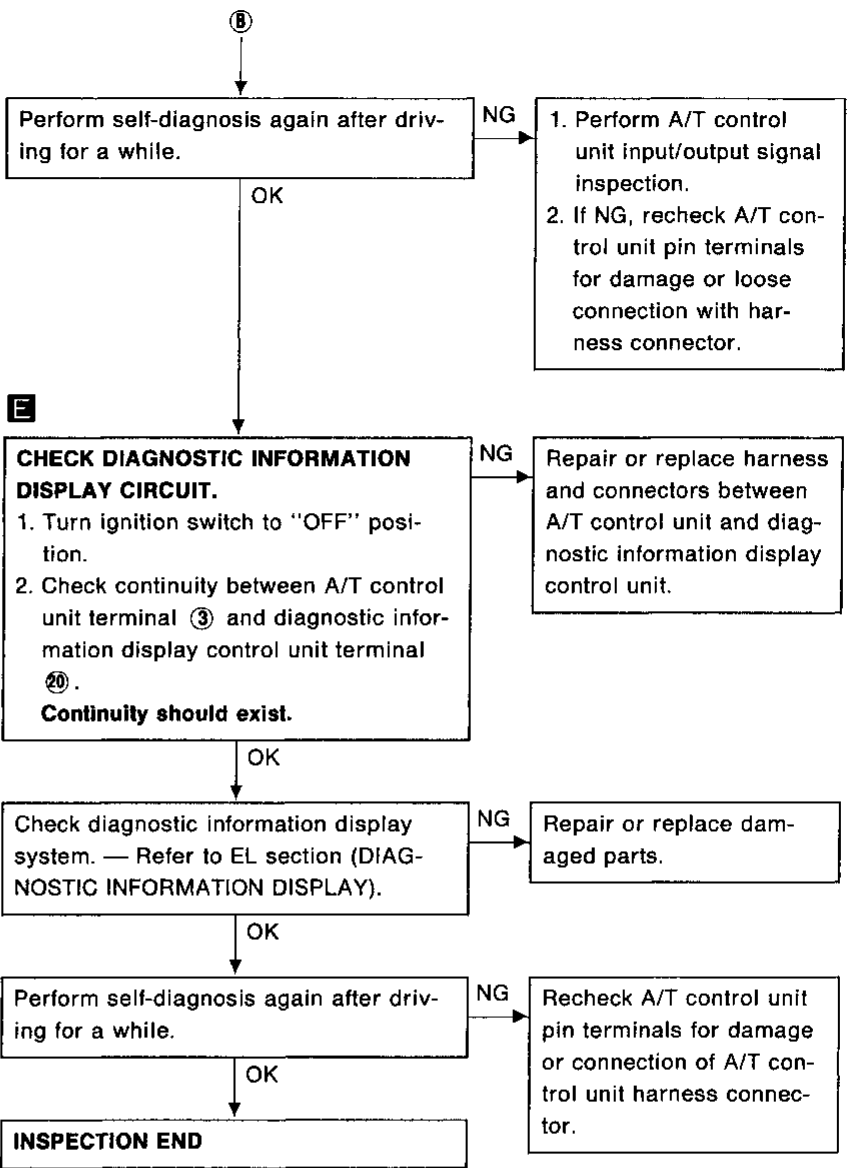
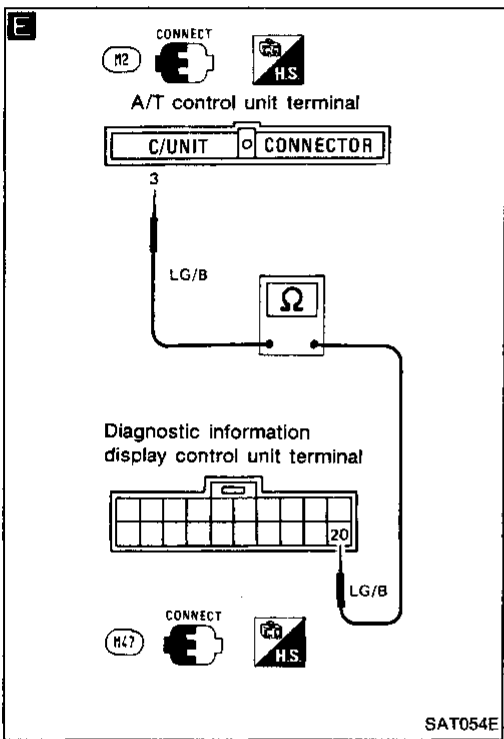
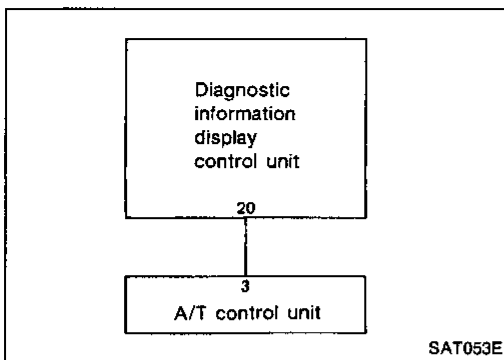

## Diagnostic Procedure 1

**SYMPTOM: Engine cannot be started with selector lever in "P" or "N" position.  
Engine can be started with selector lever in "D", "3", "2", "1", or "R" position.**

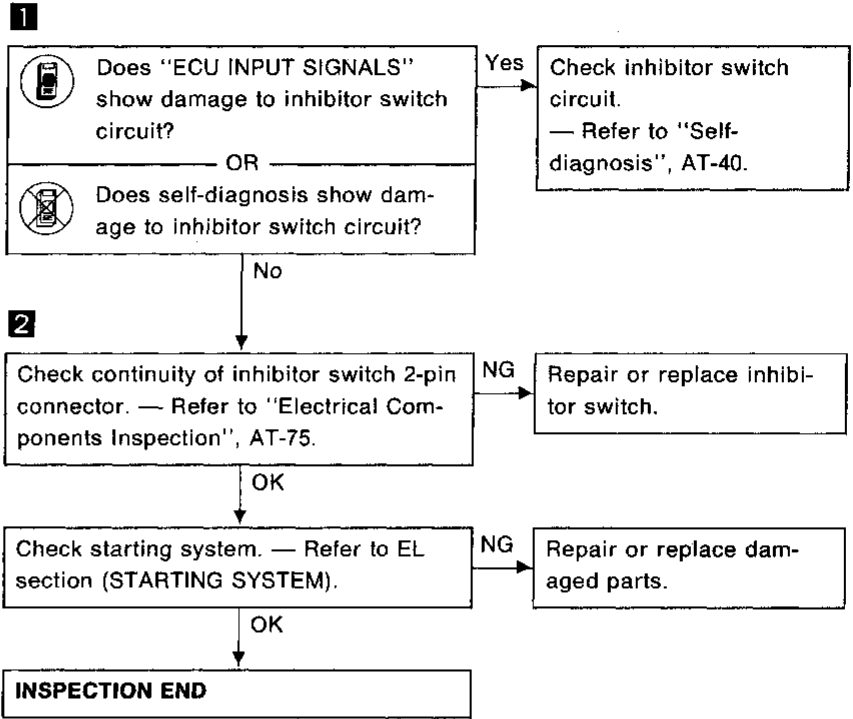
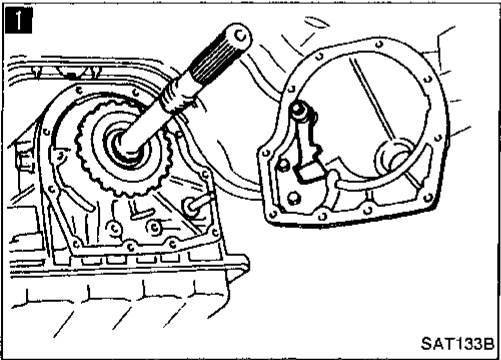
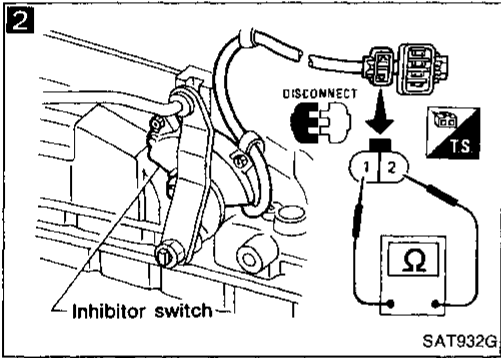
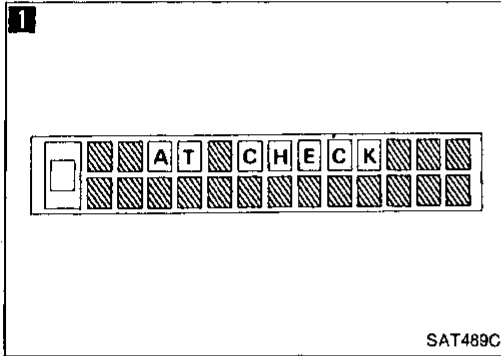

## Diagnostic Procedure 2

**SYMPTOM: Vehicle moves when it is pushed forward or backward with selector lever in "P" position.**

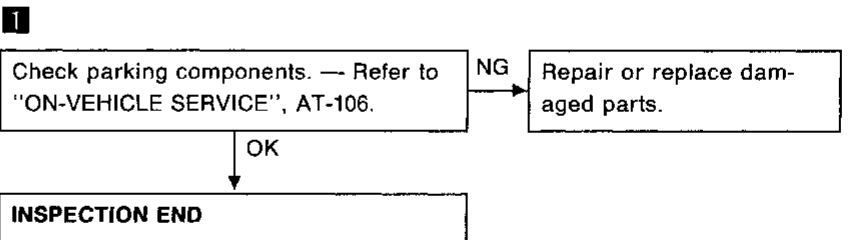

GI  
 MA  
 EM  
 LC  
 EF & EC  
 FE  
 AT  
 PD  
 FA  
 RA  
 BR  
 ST  
 RS  
 BT  
 HA  
 EL  
 IDX

## Diagnostic Procedure 3

**SYMPTOM: Vehicle moves forward or backward when selecting "N" position.**

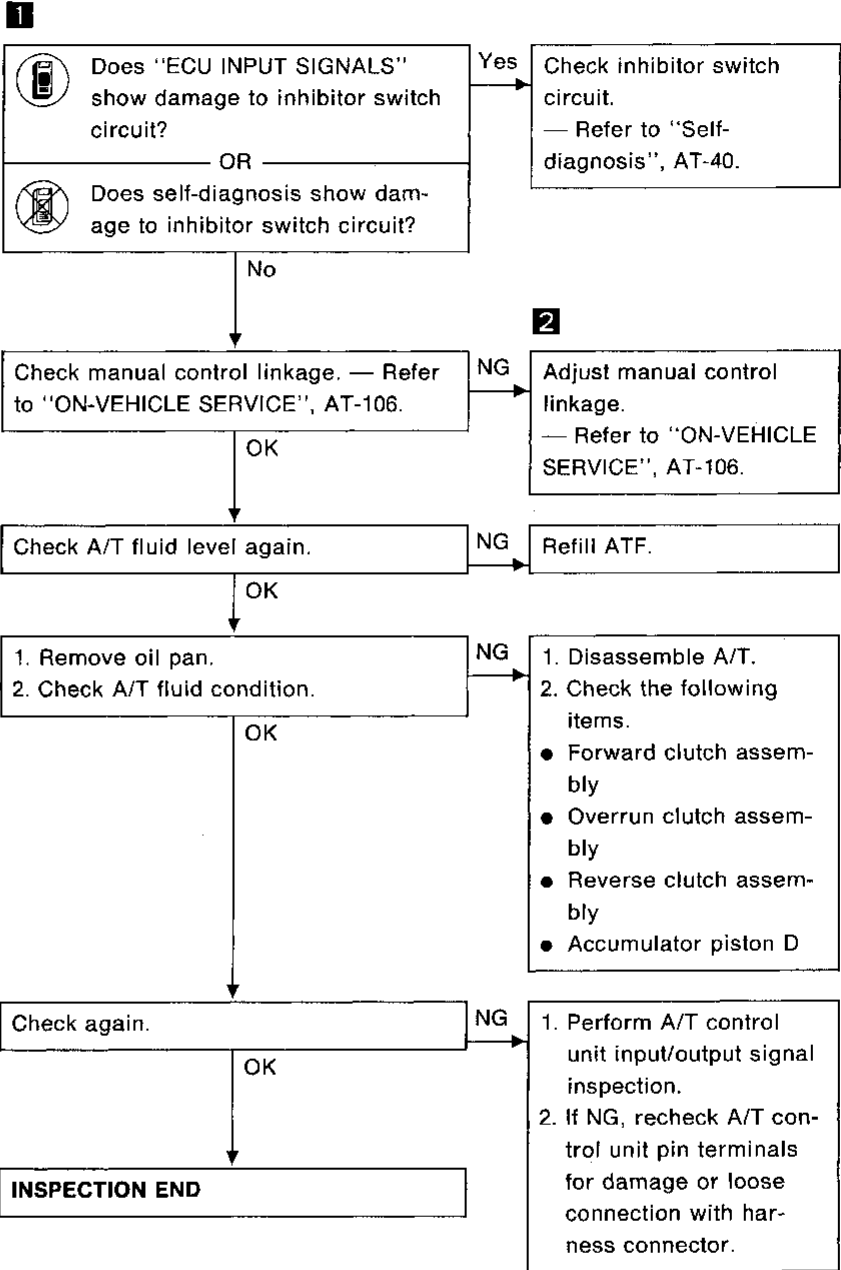
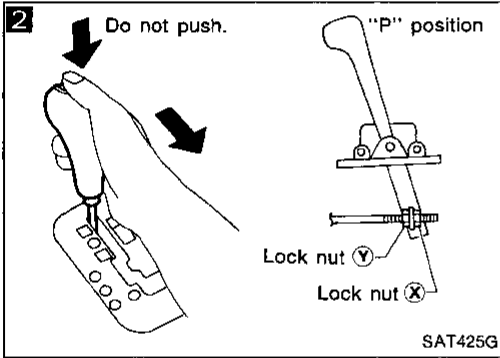
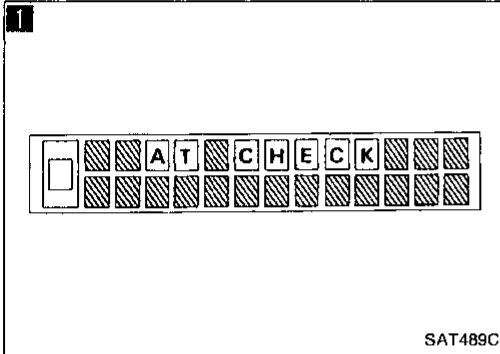

**Diagnostic Procedure 4**

**SYMPTOM: There is large shock when changing from "N" to "R" position.**

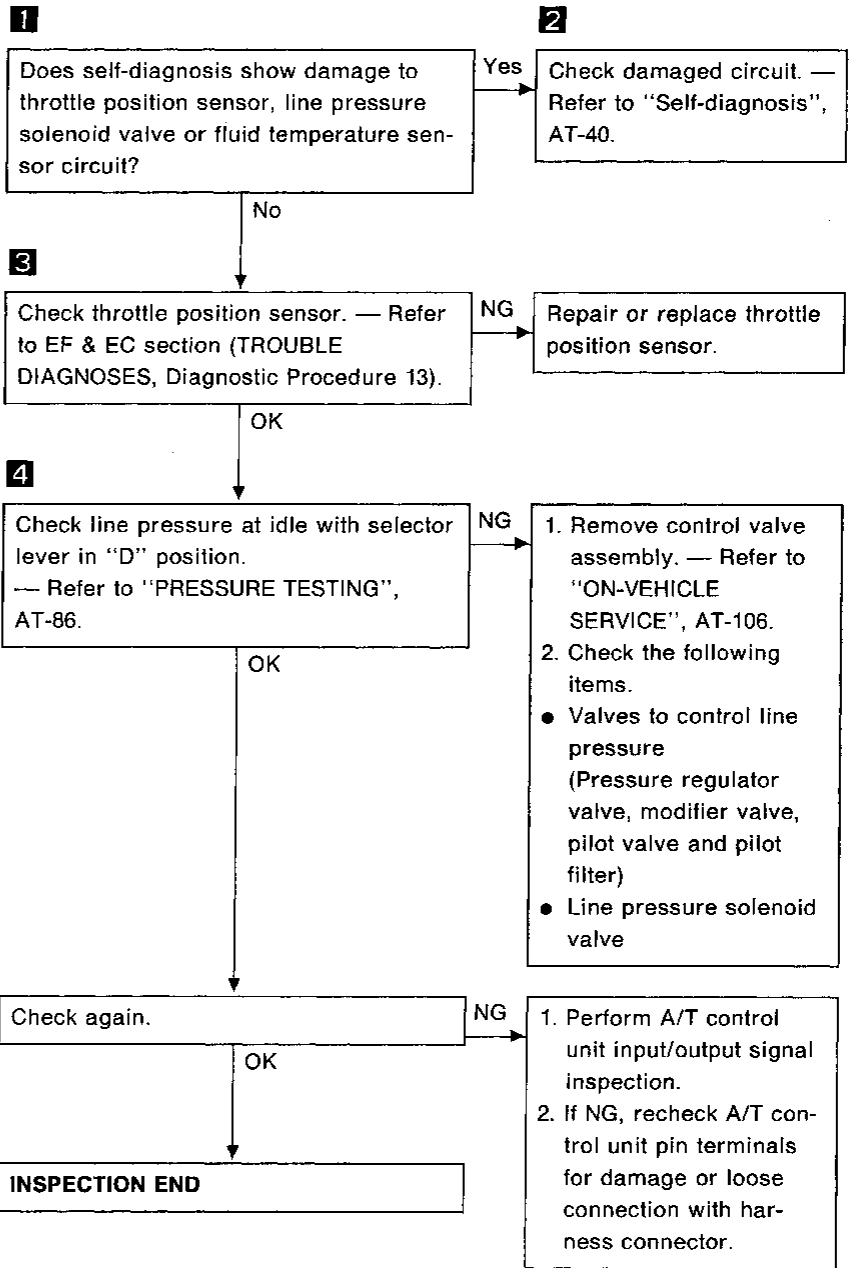
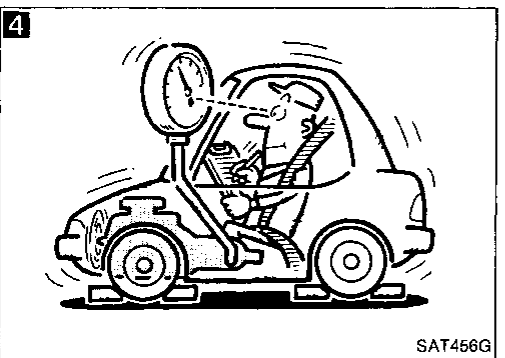
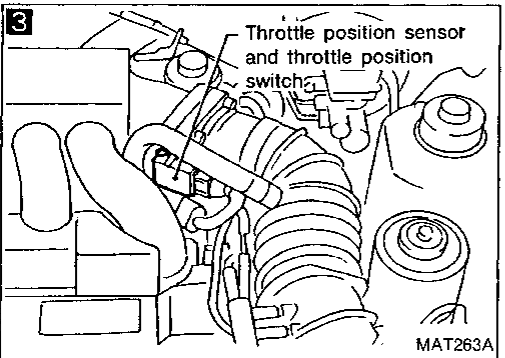
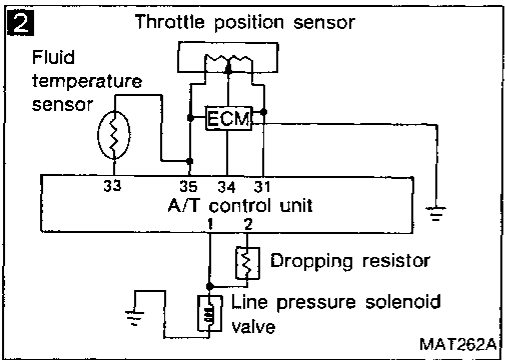
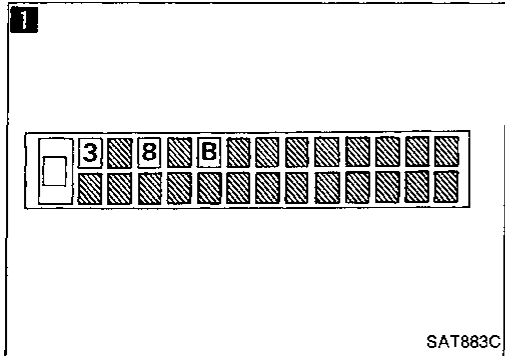

GI  
MA  
EM  
LC  
EF & EC  
FE  
AT  
PD  
FA  
RA  
BR  
ST  
RS  
BT  
HA  
EL  
DX

# TROUBLE DIAGNOSES

## Diagnostic Procedure 5

**SYMPTOM: Vehicle does not creep backward when selecting "R" position.**

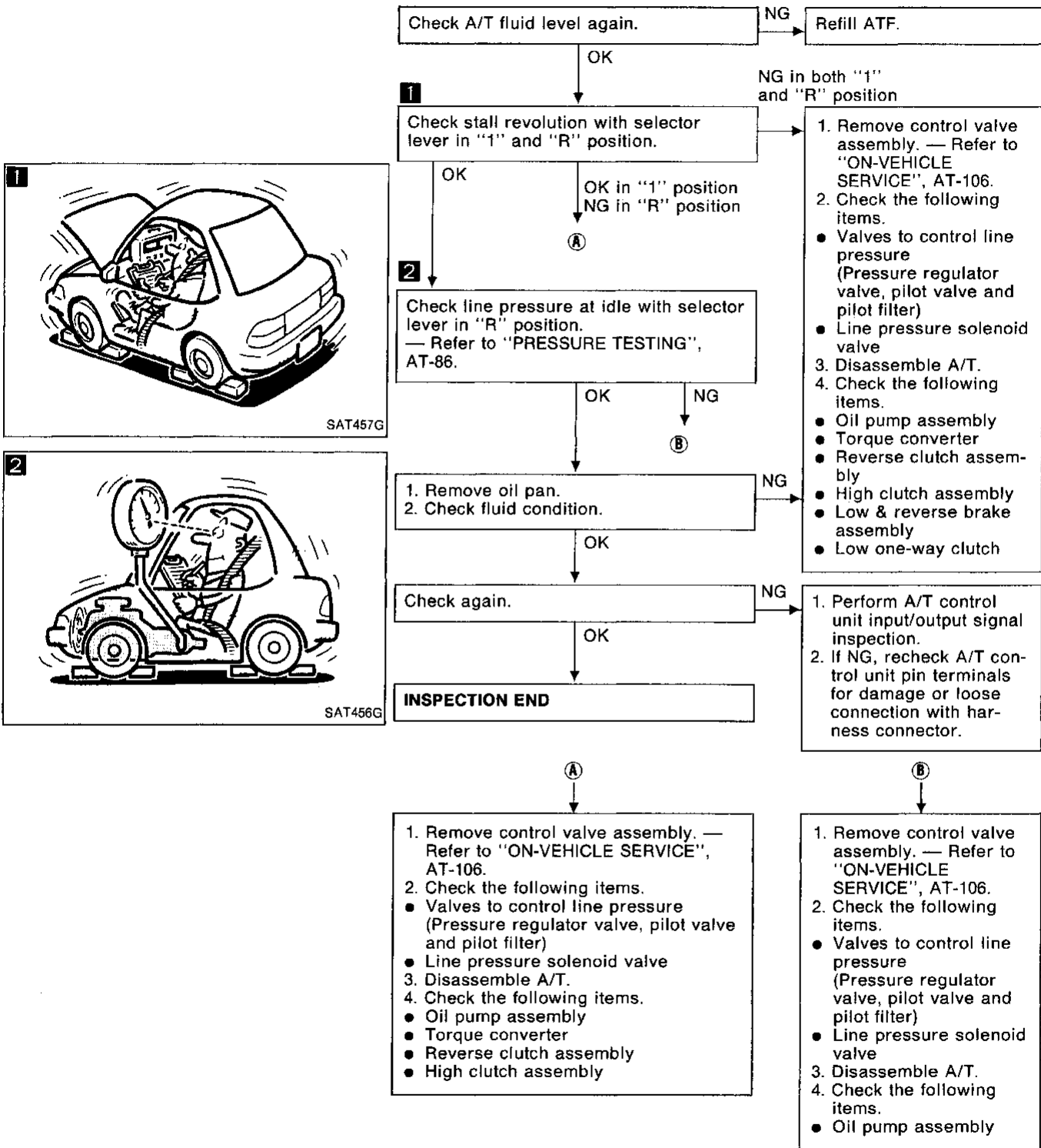

**Diagnostic Procedure 6**

**SYMPTOM: Vehicle does not creep forward when selecting "D", "3", "2" or "1" position.**

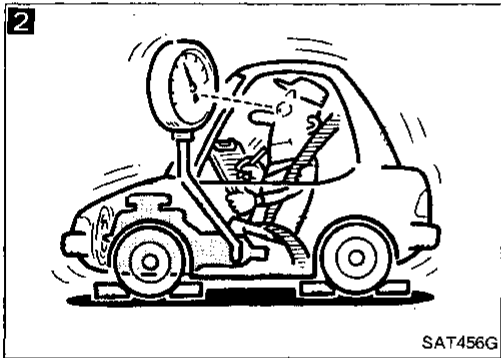
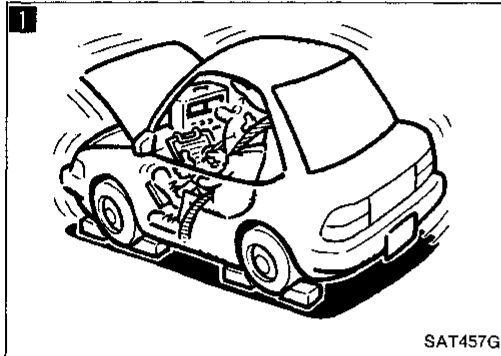
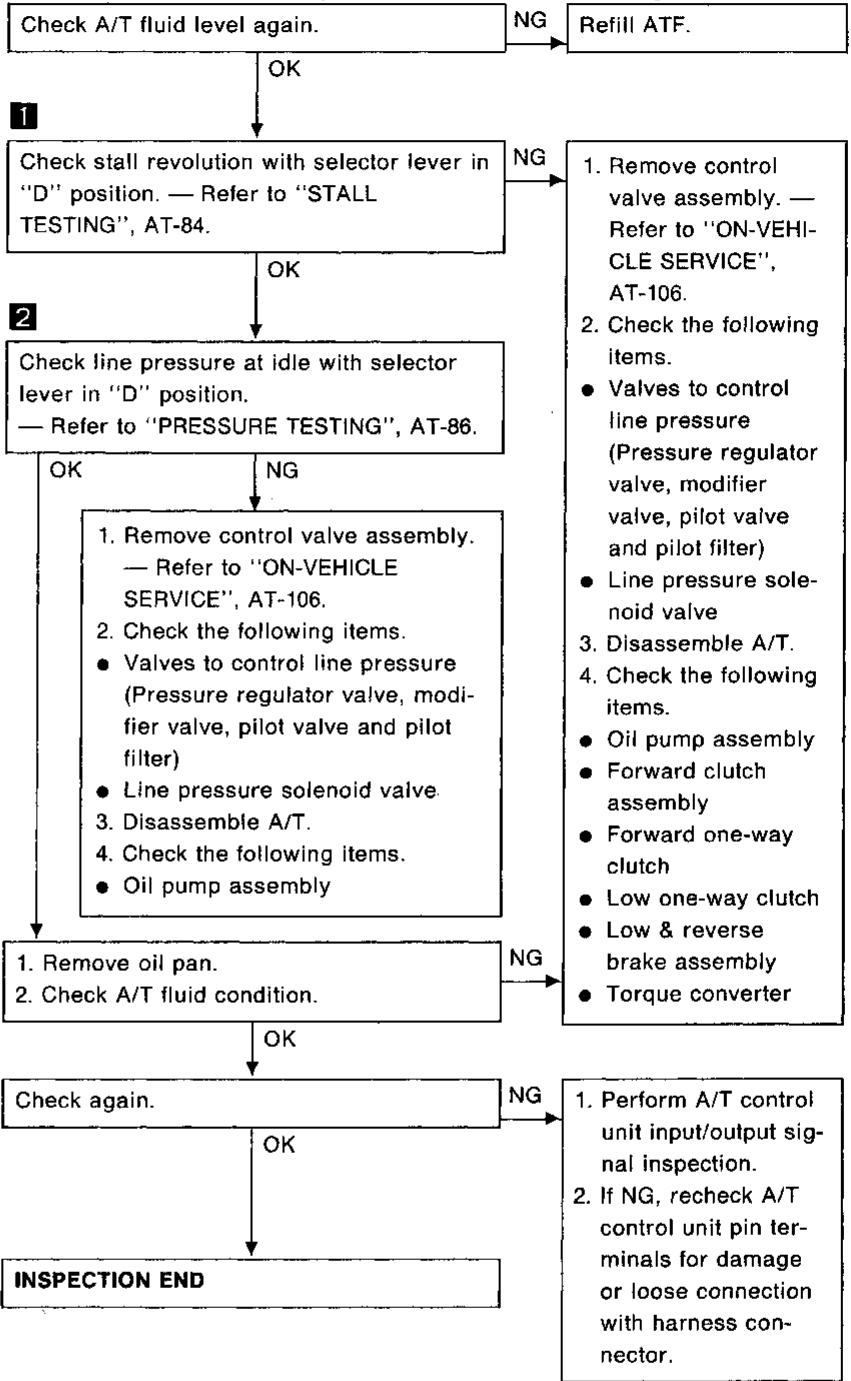

GI  
MA  
EM  
LC  
EF & EC  
FE  
AT  
PD  
FA  
RA  
BR  
ST  
RS  
BT  
HA  
EL  
IDX

## Diagnostic Procedure 7

**SYMPTOM: Vehicle cannot be started from D<sub>1</sub> on Cruise test — Part 1.**

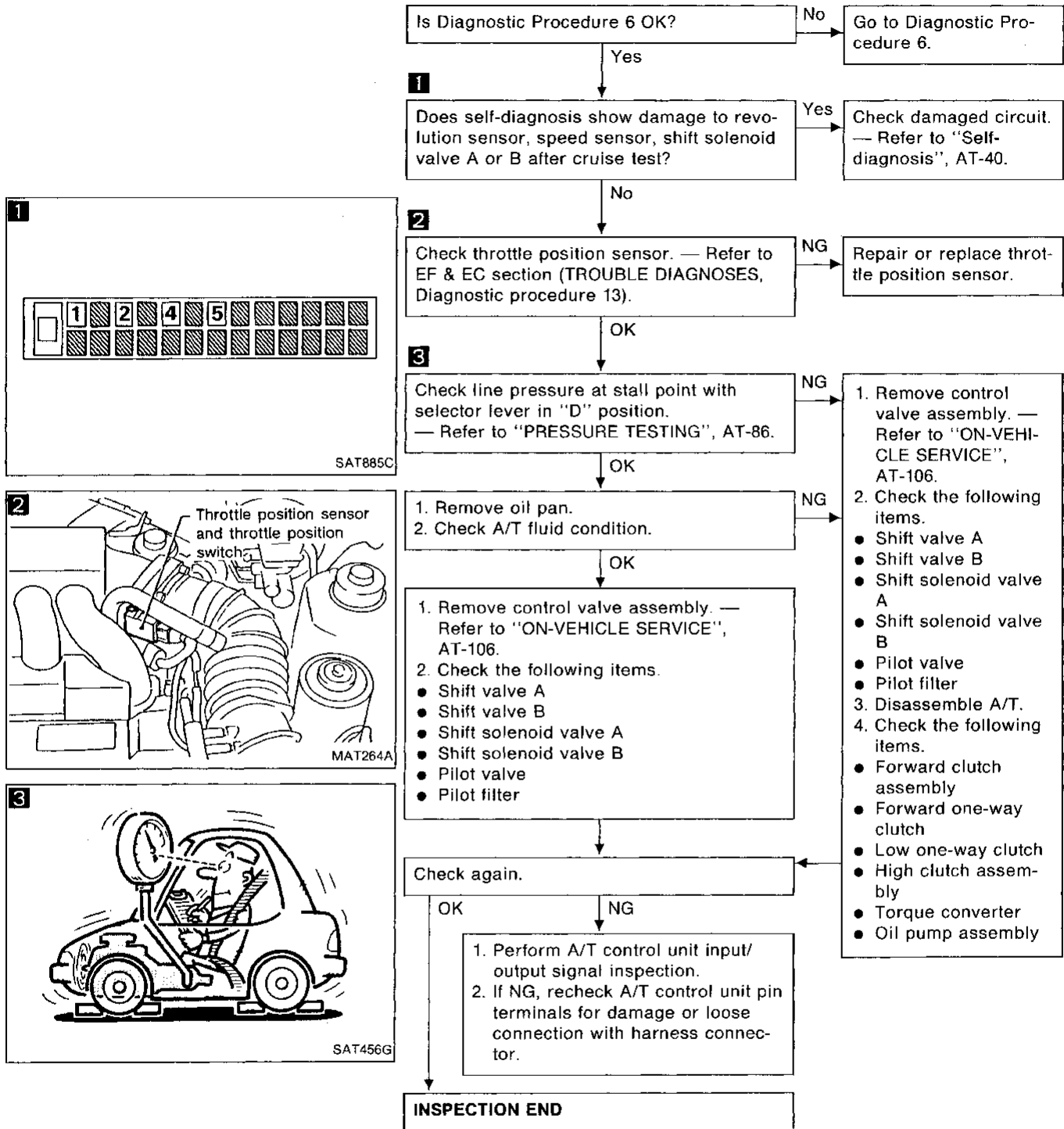



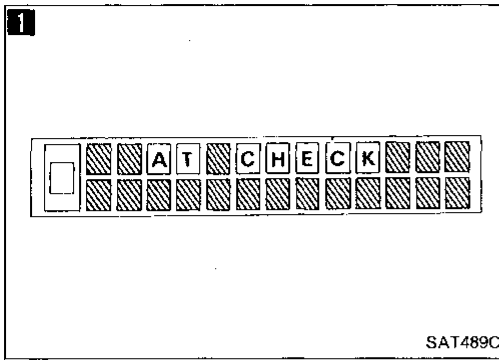

## Diagnostic Procedure 8

**SYMPTOM: A/T does not shift from D<sub>1</sub> to D<sub>2</sub> at the specified speed.**  
**A/T does not shift from D<sub>4</sub> to D<sub>2</sub> when depressing accelerator pedal fully at the specified speed.**

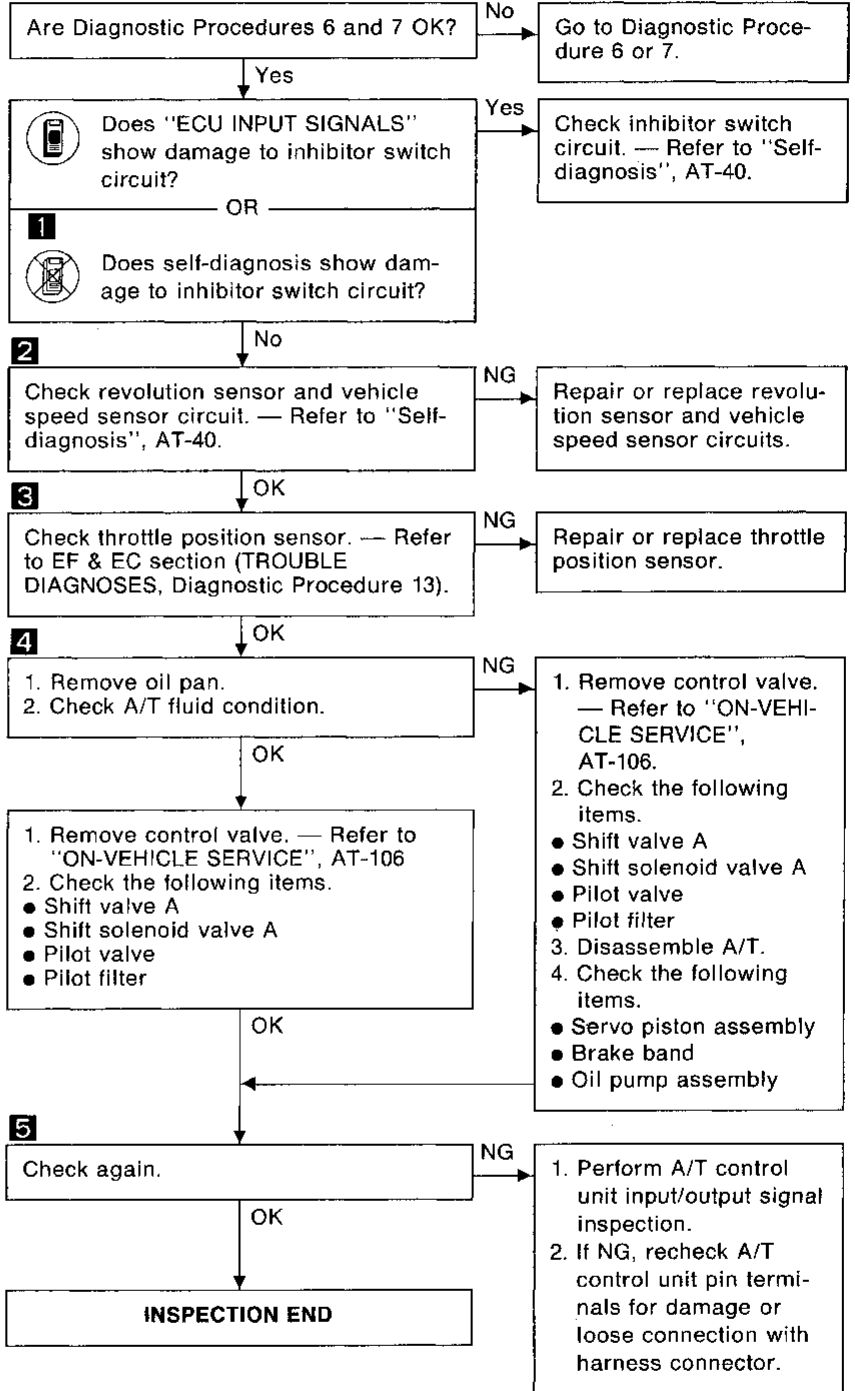
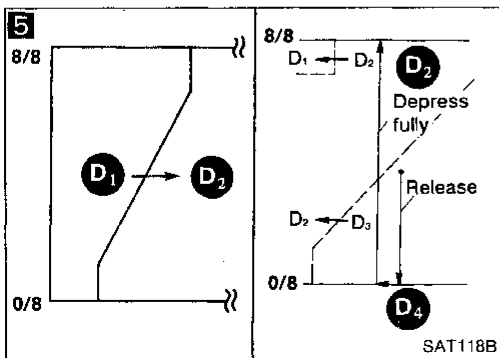
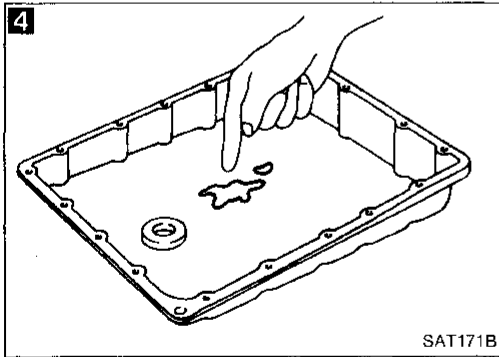
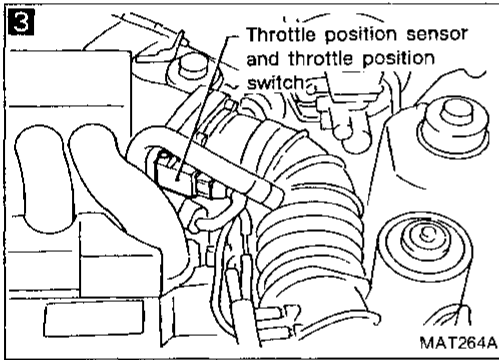
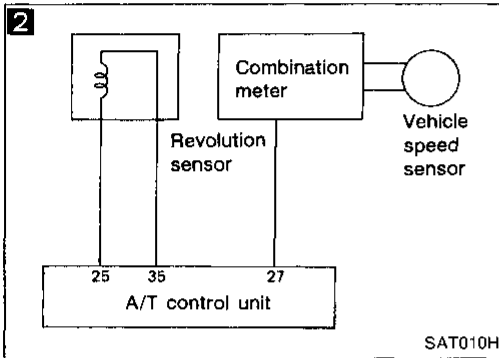

## Diagnostic Procedure 9

**SYMPTOM: A/T does not shift from D<sub>2</sub> to D<sub>3</sub> at the specified speed.**

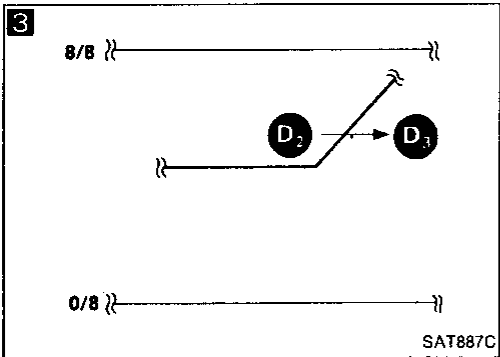
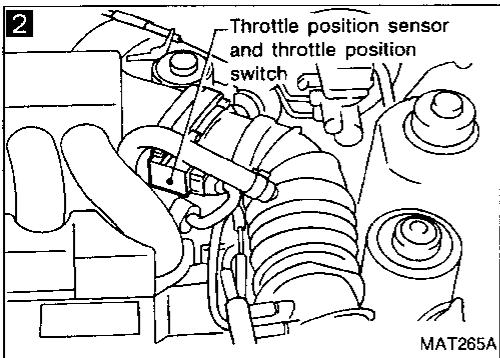
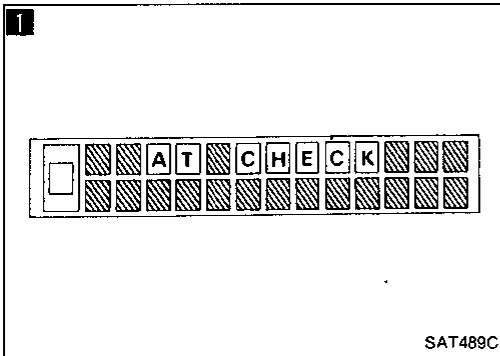
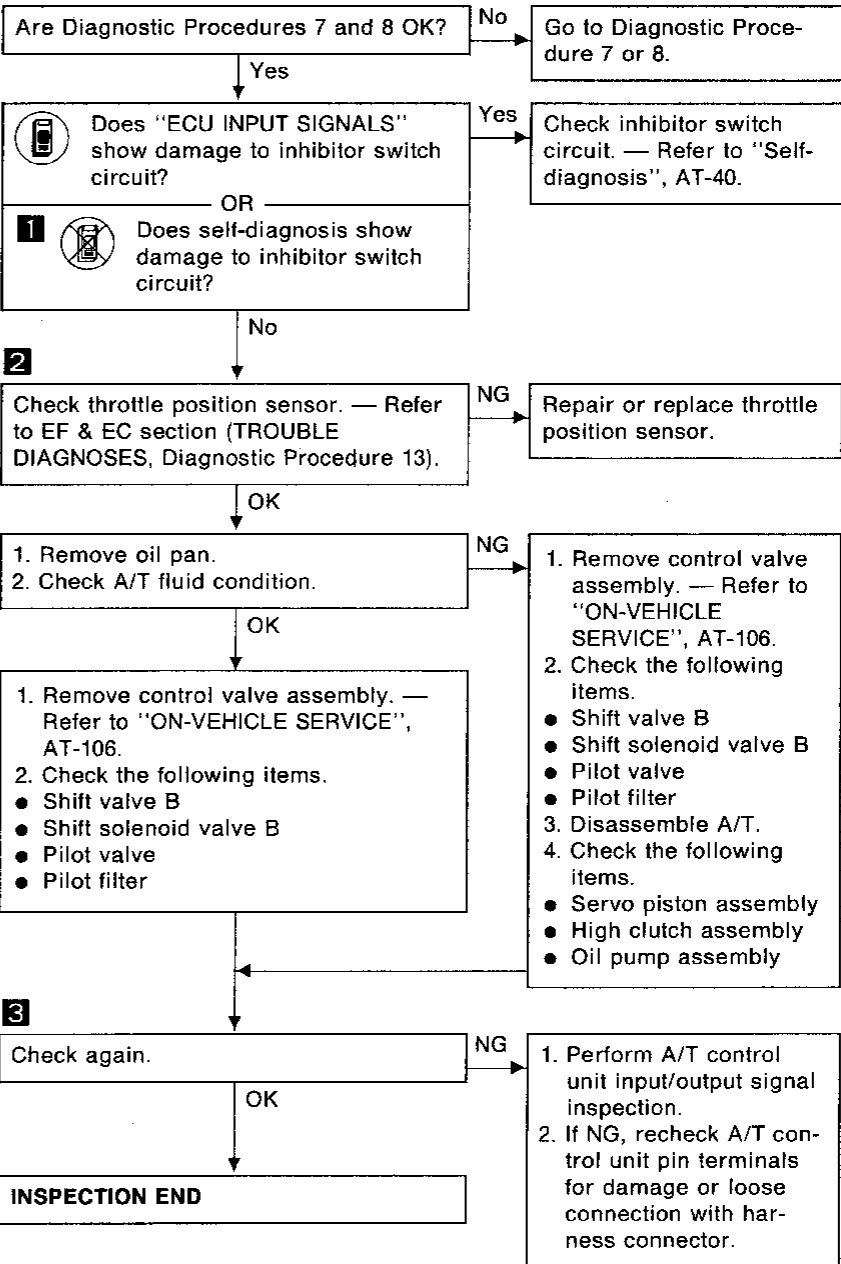

## Diagnostic Procedure 10

**SYMPTOM: A/T does not shift from D<sub>3</sub> to D<sub>4</sub> at the specified speed.**

GI  
 MA  
 EM  
 LC  
 EF & EC  
 FE  
 AT  
 PD  
 FA  
 RA  
 BR  
 ST  
 RS  
 BT  
 HA  
 EL  
 IDX

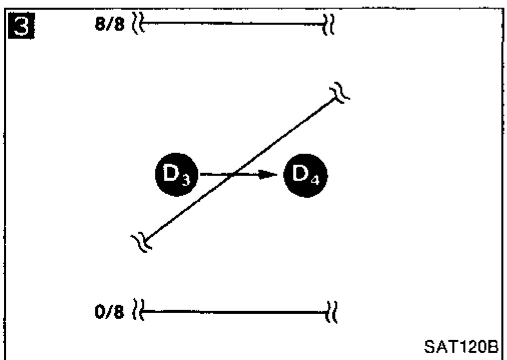
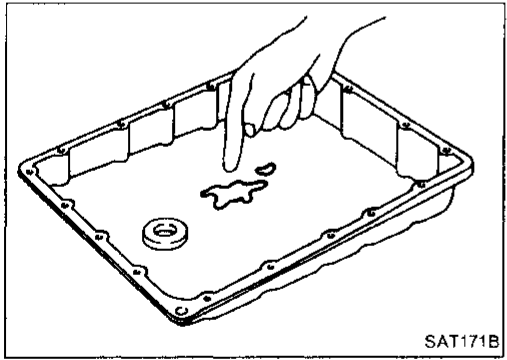
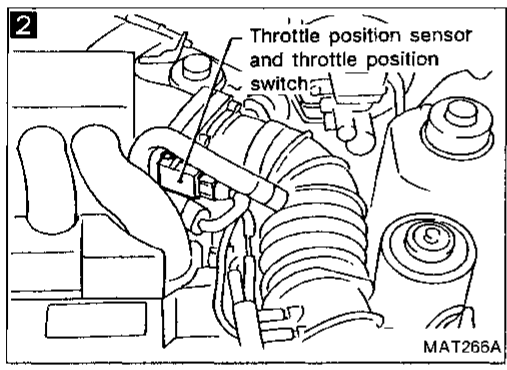
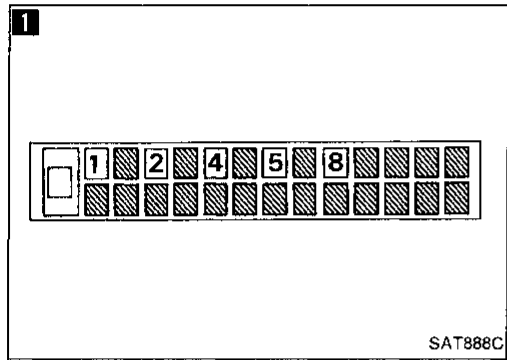
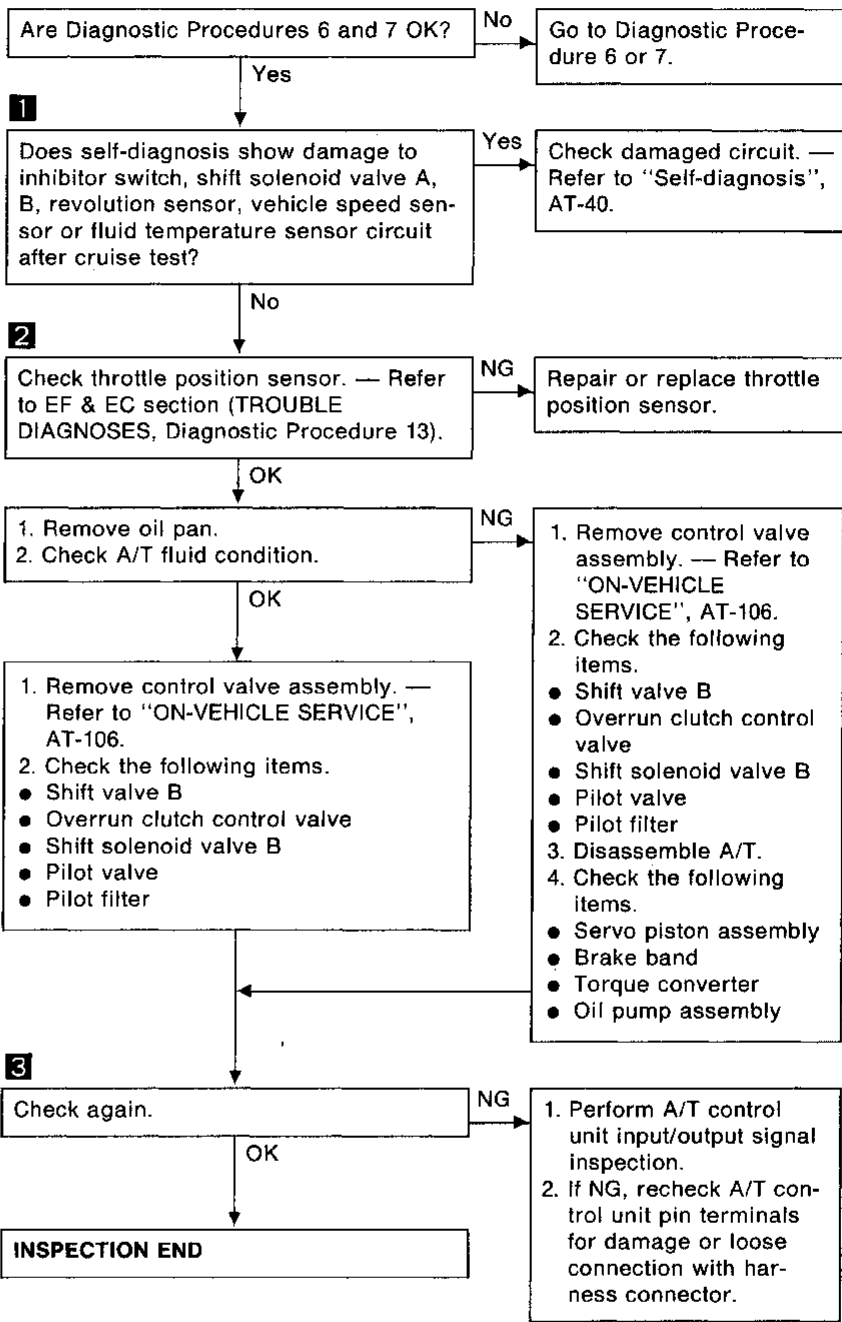

## Diagnostic Procedure 11

**SYMPTOM: A/T does not perform lock-up at the specified speed.**

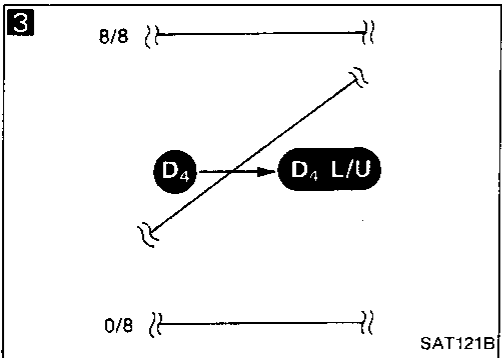
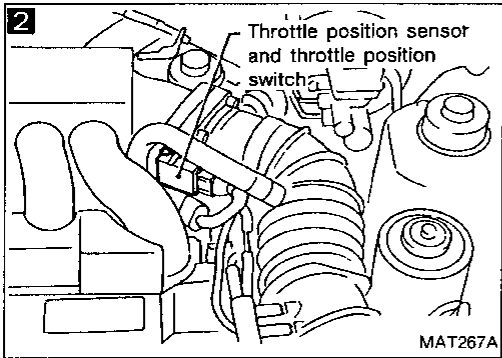
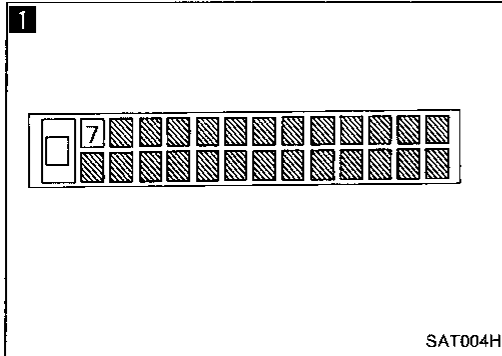
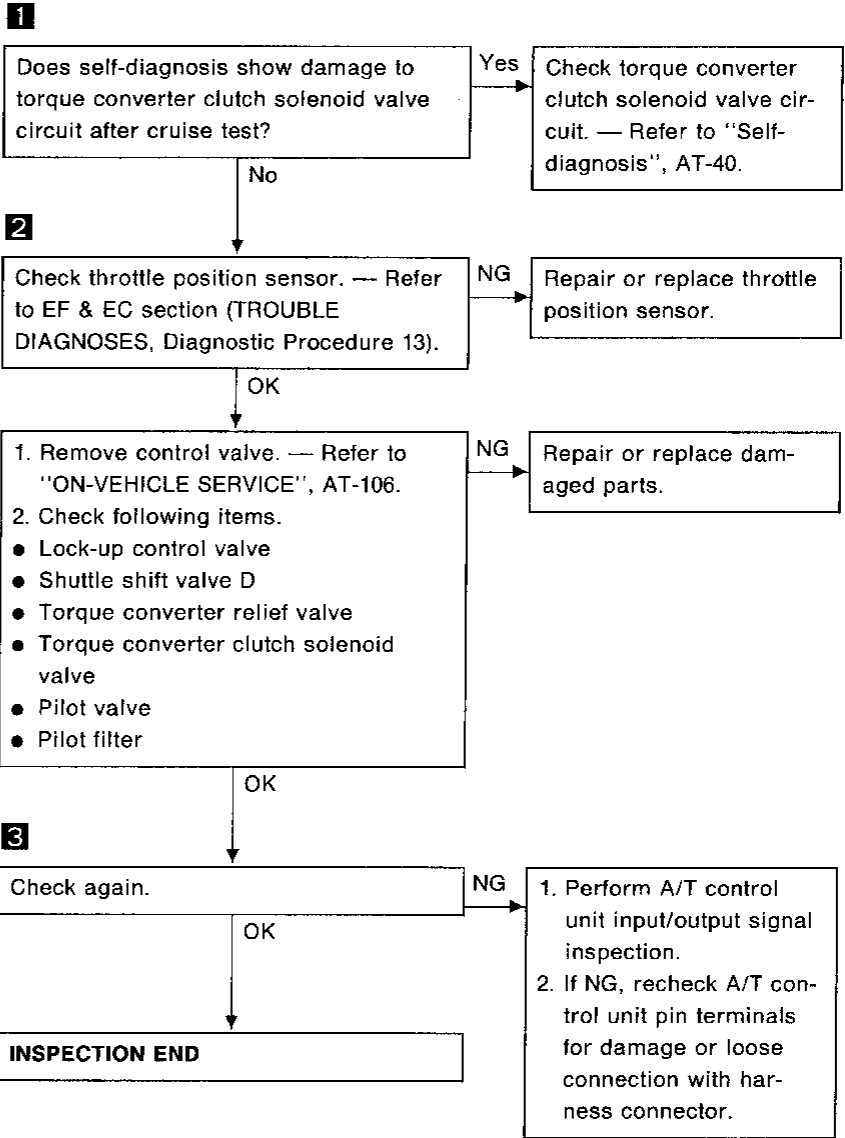

## Diagnostic Procedure 12

**SYMPTOM: A/T does not hold lock-up condition for more than 30 seconds.**

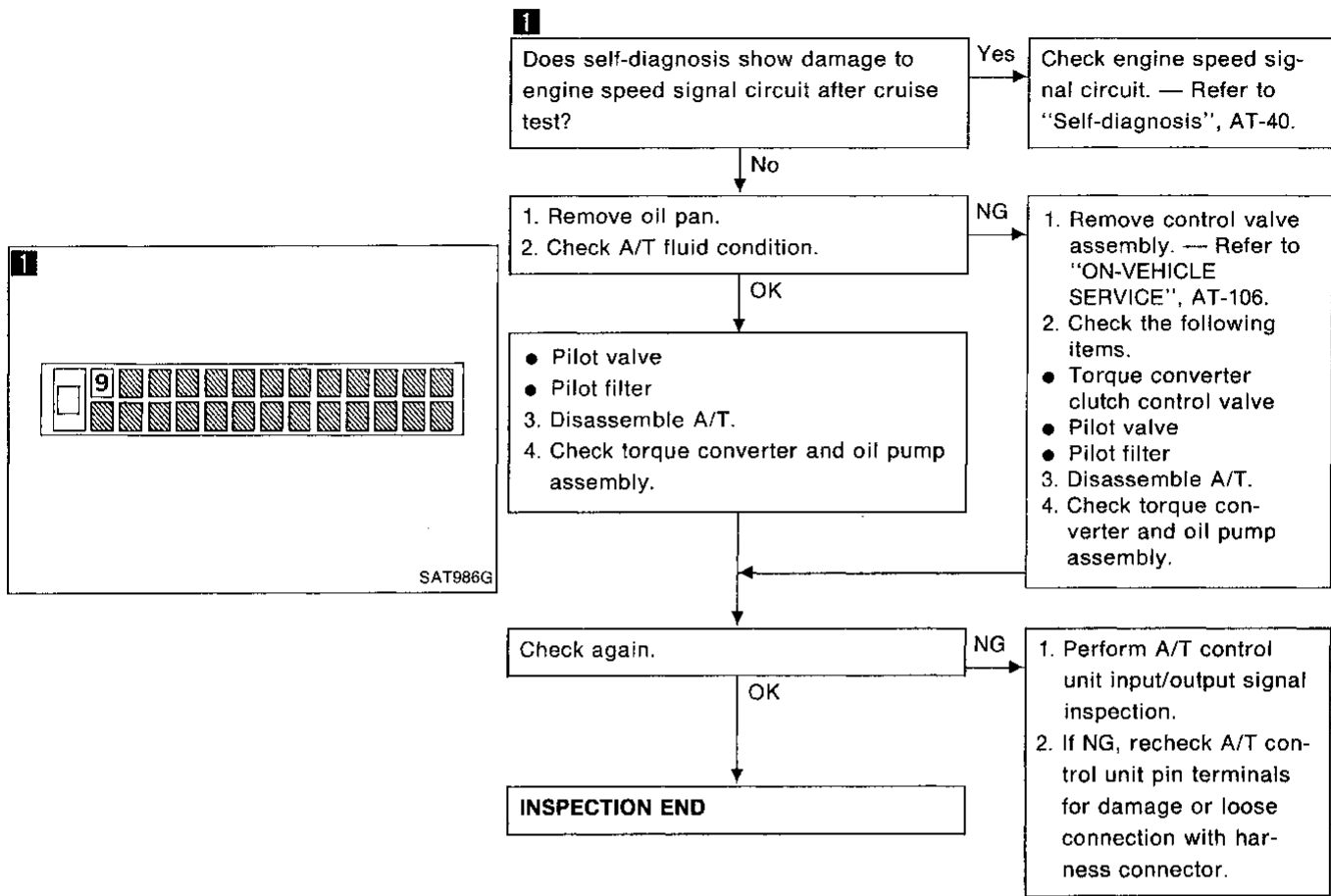

## Diagnostic Procedure 13

**SYMPTOM: Lock-up is not released when accelerator pedal is released.**

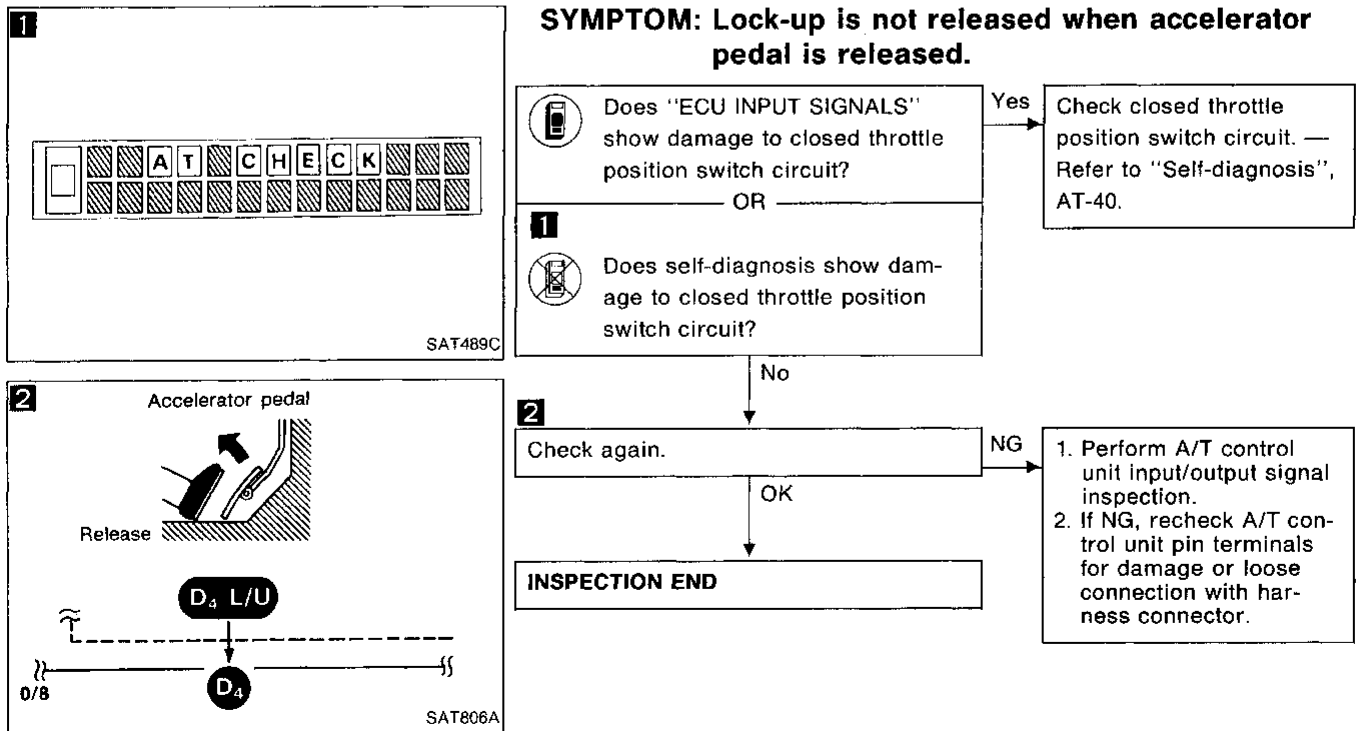

## Diagnostic Procedure 14

**SYMPTOM:** With accelerator pedal released:

- Engine does not smoothly return to idle when A/T shifts from D<sub>4</sub> to D<sub>3</sub>.
- Vehicle does not decelerate by engine brake when changing selector lever from "D" to "3" position.
- Vehicle does not decelerate by engine brake when changing selector lever from "3" to "2" position.

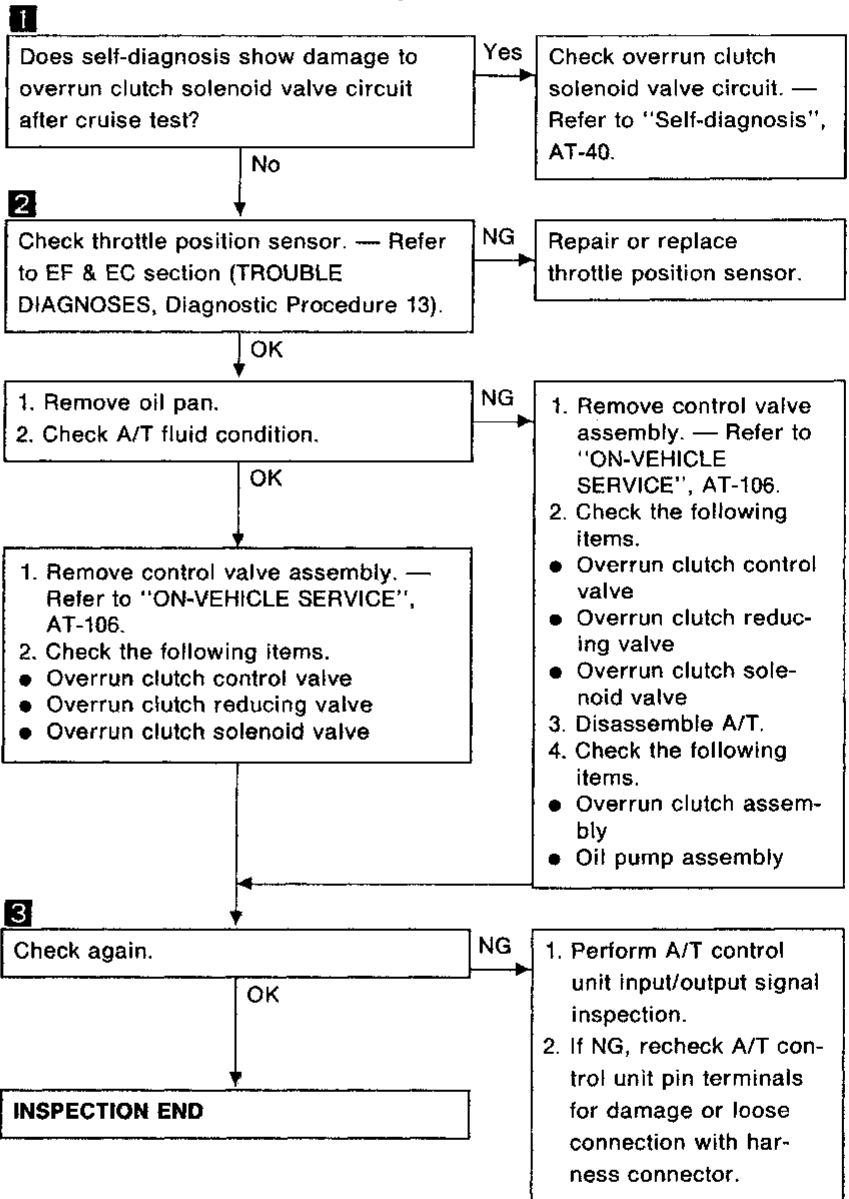
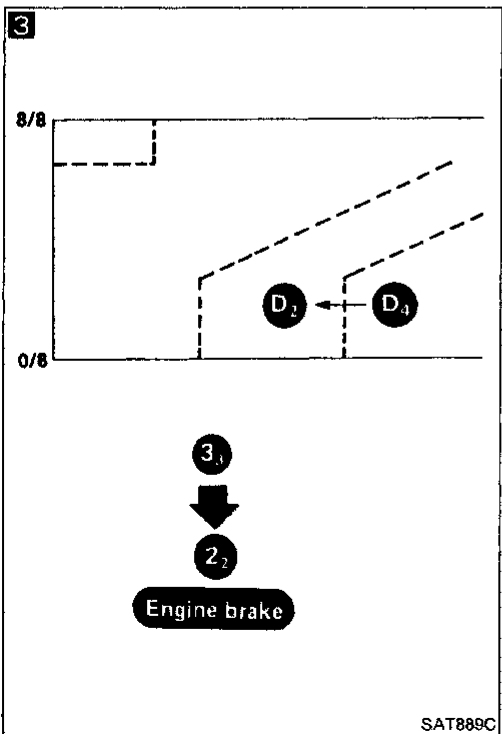
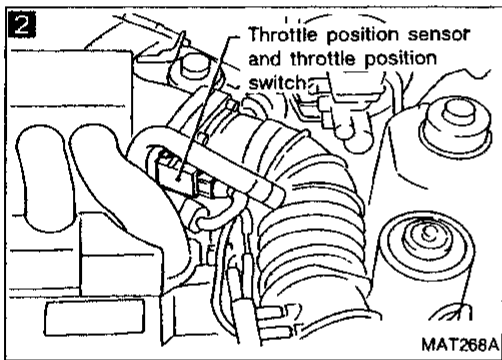
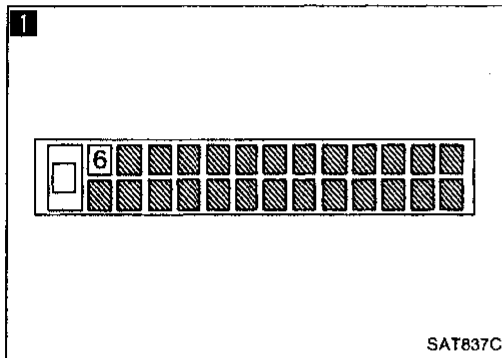

# TROUBLE DIAGNOSES

## Diagnostic Procedure 15

SYMPTOM: Vehicle does not start from D<sub>1</sub> on Cruise test  
— Part 2.

**1**

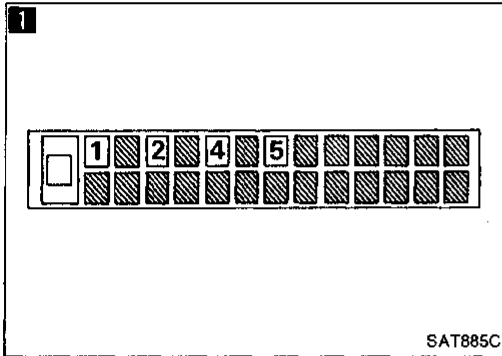
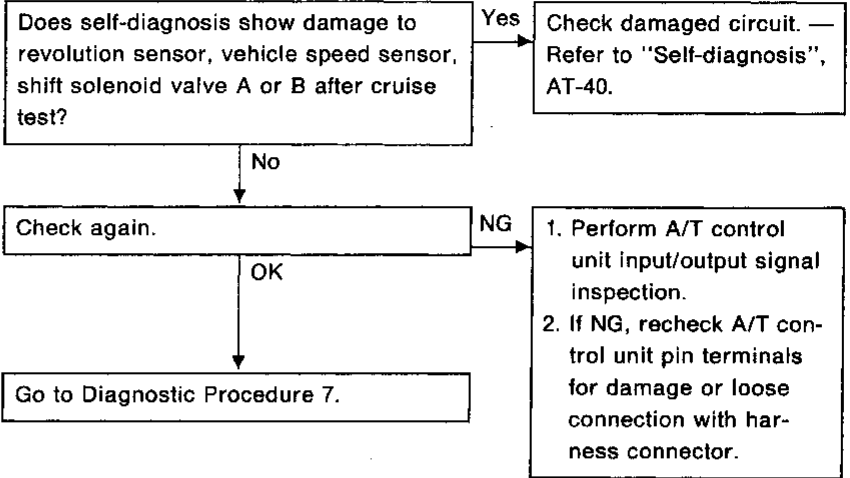

GI

MA

EM

LC

EF & EC

FE

**AT**

PD

FA

RA

BR

ST

RS

BT

HA

EL

IDX

## Diagnostic Procedure 16

**SYMPTOM: A/T does not shift from D<sub>4</sub> to D<sub>2</sub> when depressing accelerator pedal fully at the specified speed.**

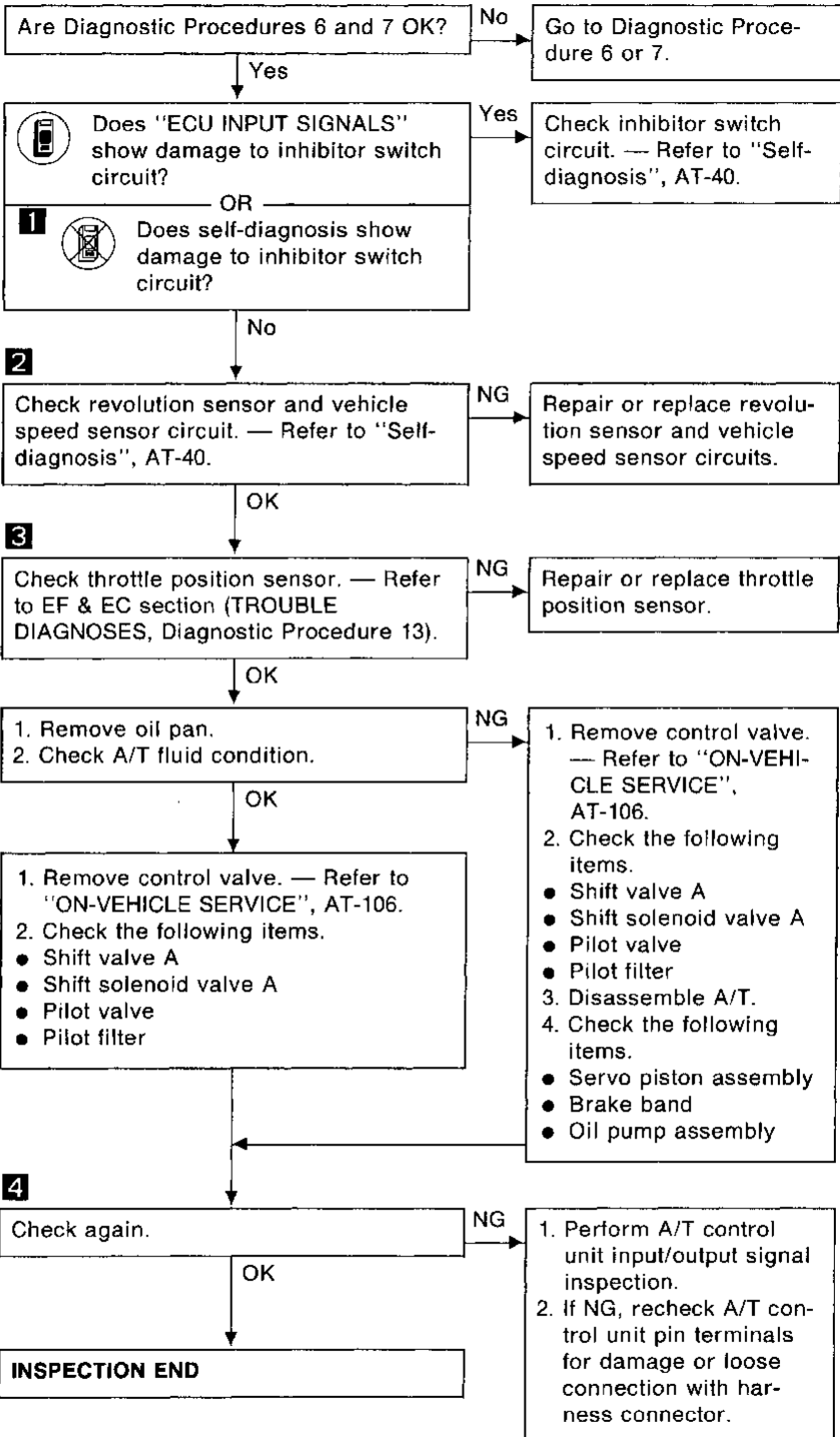
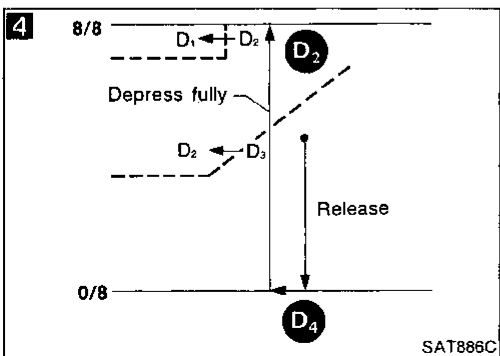
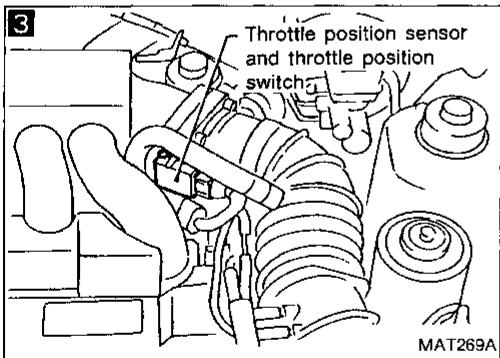
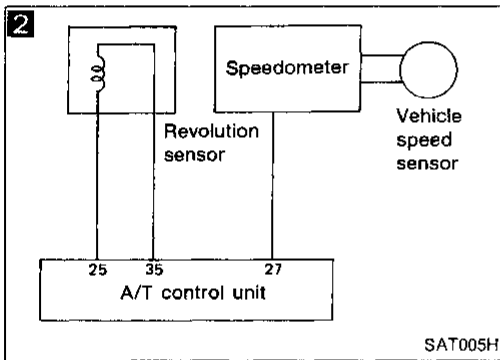
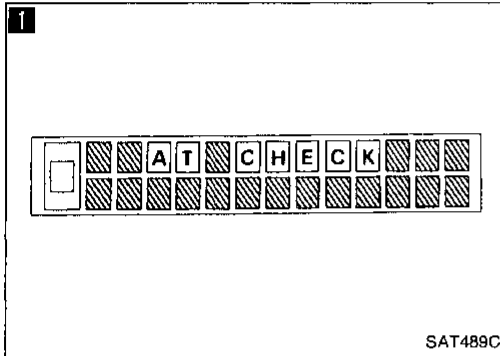



**Diagnostic Procedure 17**

**SYMPTOM: A/T does not shift from D<sub>2</sub> to D<sub>1</sub> when depressing accelerator pedal fully at the specified speed.**

GI  
MA  
EM  
LC  
EF & EC  
FE  
AT  
PD  
FA  
RA  
BR  
ST  
RS  
BT  
HA  
EL  
IDX

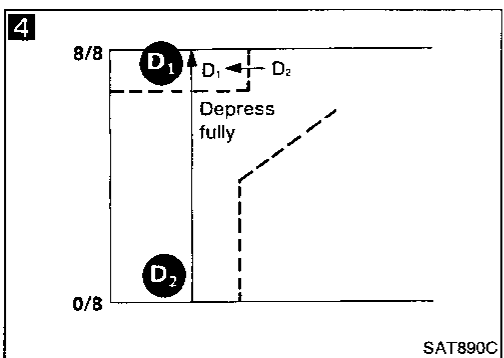
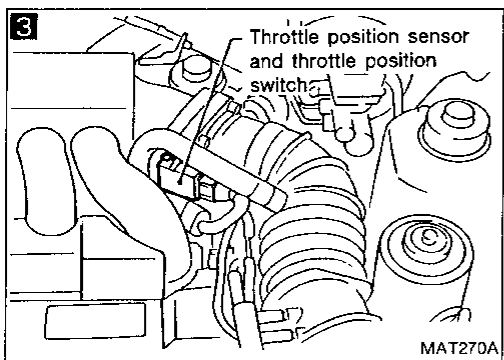
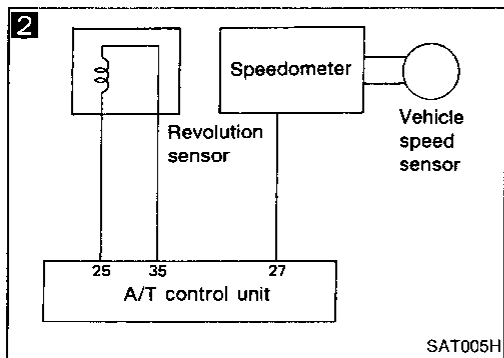
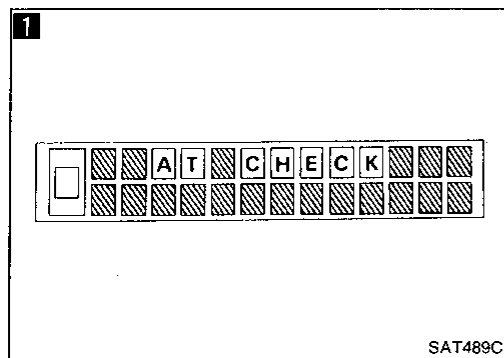

```

    graph TD
        Q1{Are Diagnostic Procedures 6 and 7 OK?} -- No --> A1[Go to Diagnostic Procedure 6 or 7.]
        Q1 -- Yes --> Q2{Does "ECU INPUT SIGNAL" show damage to inhibitor switch and 1 position switch circuit?}
        Q2 -- Yes --> A2[Check inhibitor switch 1 position switch circuit. — Refer to "Self-diagnosis", AT-40.]
        Q2 -- OR --> Q3{Does self-diagnosis show damage to inhibitor switch circuit?}
        Q3 -- No --> Q4{Check revolution sensor and vehicle speed sensor circuits. — Refer to "Self-diagnosis", AT-40.}
        Q4 -- NG --> A3[Repair or replace revolution sensor and vehicle speed sensor circuits.]
        Q4 -- OK --> Q5{Check throttle position sensor. — Refer to EF & EC section (TROUBLE DIAGNOSES, Diagnostic Procedure 13).}
        Q5 -- NG --> A4[Repair or replace throttle position sensor.]
        Q5 -- OK --> Q6{1. Remove oil pan.  
2. Check A/T fluid condition.}
        Q6 -- NG --> A5["1. Remove control valve. — Refer to "ON-VEHICLE SERVICE", AT-106.  
2. Check the following items:  
● Shift valve A  
● Shift solenoid valve A  
● Pilot valve  
● Pilot filter"]
        Q6 -- OK --> Q7{1. Remove control valve. — Refer to "ON-VEHICLE SERVICE", AT-106.  
2. Check the following items:  
● Shift valve A  
● Shift solenoid valve A  
● Pilot valve  
● Pilot filter}
        Q7 --> A6["1. Remove control valve. — Refer to "ON-VEHICLE SERVICE", AT-106.  
2. Check the following items:  
● Shift valve A  
● Shift solenoid valve A  
● Pilot valve  
● Pilot filter  
3. Disassemble A/T.  
4. Check the following items:  
● Servo piston assembly  
● Brake band  
● Oil pump assembly"]
        A6 --> Q8{Check again.}
        Q8 -- NG --> A7["1. Perform A/T control unit input/output signal inspection.  
2. If NG, recheck A/T control unit pin terminals for damage or loose connection with harness connector."]
        Q8 -- OK --> END[INSPECTION END]
    
```

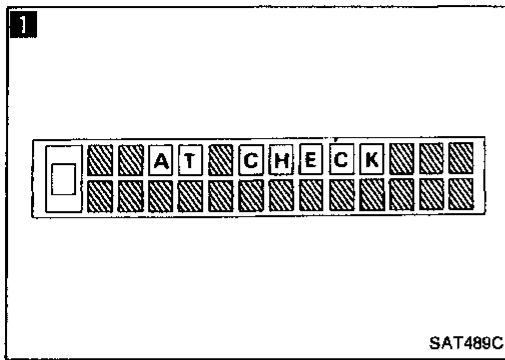

## Diagnostic Procedure 18

**SYMPTOM: A/T does not shift from D<sub>4</sub> to 3<sub>3</sub> when changing selector lever from "D" to "3" position.**

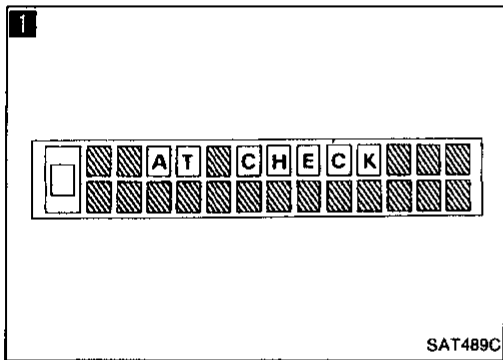
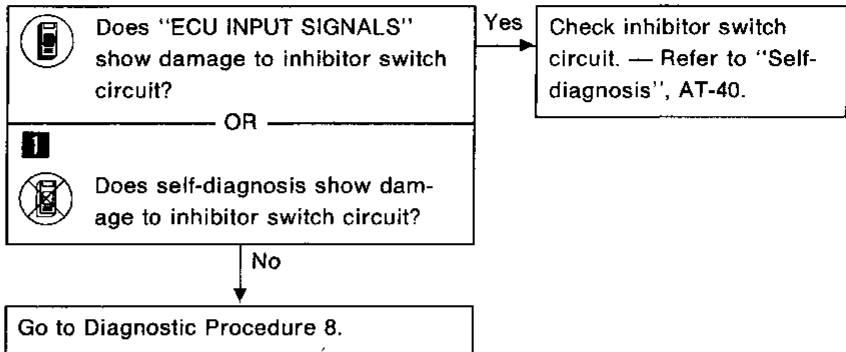

## Diagnostic Procedure 19

**SYMPTOM: A/T does not shift from 3<sub>3</sub> to 2<sub>2</sub> when changing selector lever from "3" to "2" position.**

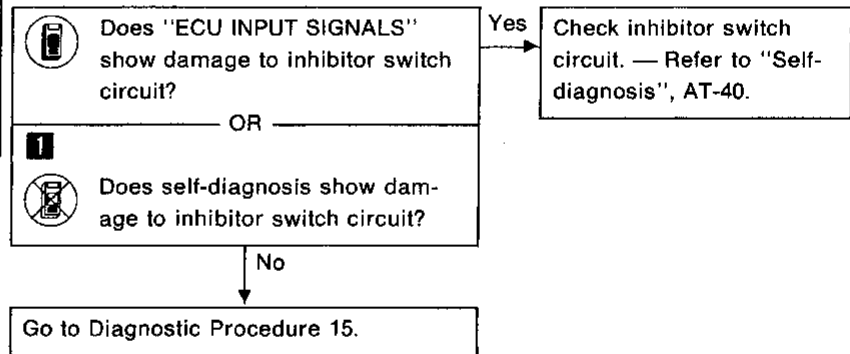

# TROUBLE DIAGNOSES

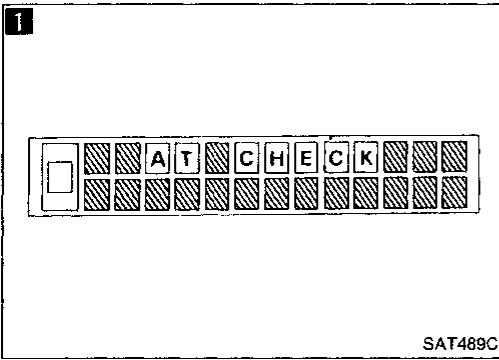

## Diagnostic Procedure 20

**SYMPTOM: A/T does not shift from 2<sub>2</sub> to 1<sub>1</sub>, when changing selector lever from "2" to "1" position.**

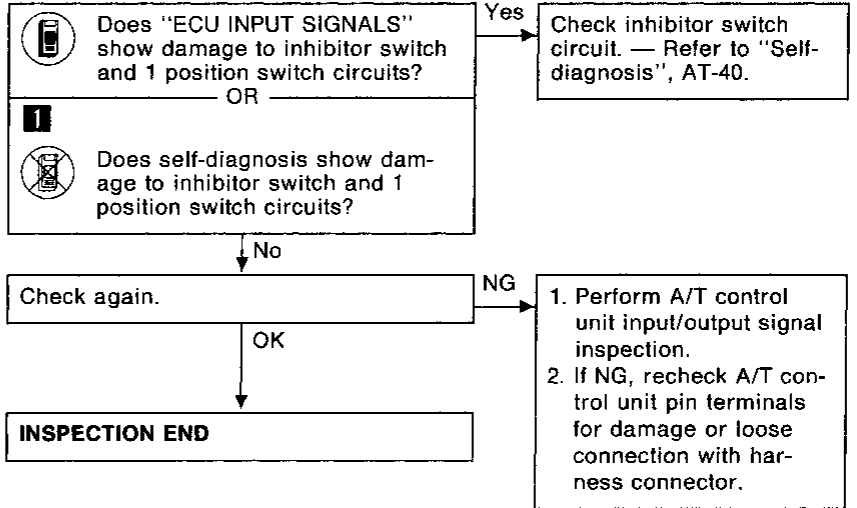

## Diagnostic Procedure 21

**SYMPTOM: Vehicle does not decelerate by engine brake when shifting from 2<sub>2</sub> (1<sub>2</sub>) to 1<sub>1</sub>.**

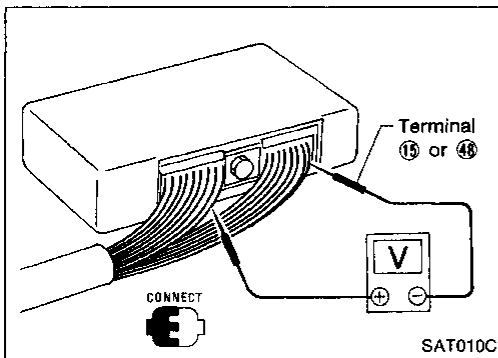
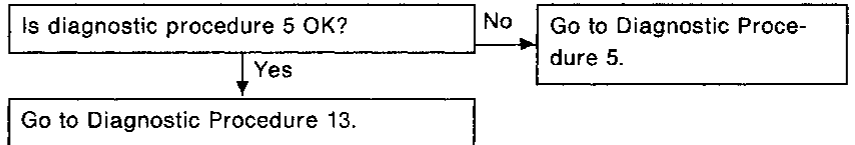

## Electrical Components Inspection

### INSPECTION OF A/T CONTROL UNIT

- Measure voltage between each terminal and terminal 15 or 48 by following "A/T CONTROL UNIT INSPECTION TABLE".
- Pin connector terminal layout.



SAT934G

# TROUBLE DIAGNOSES

## Electrical Components Inspection (Cont'd)

### A/T CONTROL UNIT INSPECTION TABLE



(Data are reference values.)

Terminal No.	Item	Condition	Judgment standard
1	Line pressure solenoid valve	When accelerator pedal is released after warming up engine.	1.5 - 2.5V
		When accelerator pedal is depressed fully after warming up engine.	0.5V or less
2	Line pressure solenoid valve (with dropping resistor)	When accelerator pedal is released after warming up engine.	5 - 14V
		When accelerator pedal is depressed fully after warming up engine.	0.5V or less
3	A/T warning signal (Self-diagnoses result)	When electrical parts are not damaged.	Batter voltage
		When the judgment "TRANSMISSION MALFUNCTION" is displayed on diagnostic information display.	1.2V or less
4	Power source	When ignition switch is turned to "ON".	Battery voltage
		When ignition switch is turned to "OFF".	1V or less
5	Torque converter clutch solenoid valve	When A/T is performing lock-up.	8 - 15V
		When A/T is not performing lock-up.	1V or less
6	Shift solenoid valve A	When shift solenoid valve A is operating. (When driving in "D <sub>1</sub> " or "D <sub>4</sub> ".)	Battery voltage
		When shift solenoid valve A is not operating. (When driving in "D <sub>2</sub> " or "D <sub>3</sub> ".)	1V or less
7	Shift solenoid valve B	When shift solenoid valve B is operating. (When driving in "D <sub>1</sub> " or "D <sub>2</sub> ".)	Battery voltage
		When shift solenoid valve B is not operating. (When driving in "D <sub>3</sub> " or "D <sub>4</sub> ".)	1V or less
8	Overrun clutch solenoid valve	When overrun clutch solenoid is operating. (When driving in "D <sub>1</sub> " or "D <sub>4</sub> ".)	Battery voltage
		When overrun clutch solenoid is not operating. (When driving in "D <sub>2</sub> " or "D <sub>3</sub> ".)	1V or less



# TROUBLE DIAGNOSES





## Electrical Components Inspection (Cont'd)

Terminal No.	Item	Condition	Judgment standard	
9	Power source		Same as No. 4	
10*	—	—	—	GI
11*	—	—	—	
12	—	—	—	MA
13	—	—	—	
14	Closed throttle position switch (in throttle position switch)	When accelerator pedal is released after warming up engine.	8 - 15V	EM
		When accelerator pedal is depressed after warming up engine.	1V or less	LC
15	Ground	—	—	EF & EC
16	Inhibitor "2" position switch	When selector lever is set to "2" or "1" position.	Battery voltage	FE
		When selector lever is set to other positions.	1V or less	AT
17	Inhibitor "3" position switch 	When selector lever is set to "3" position.	Battery voltage	PD
		When selector lever is set to other positions.	1V or less	FA
18	Inhibitor "D" position switch 	When selector lever is set to "D" position.	Battery voltage	RA
		When selector lever is set to other positions.	1V or less	BR
19	Inhibitor "N" or "P" position switch	When selector lever is set to "N" or "P" position.	Battery voltage	ST
		When selector lever is set to other positions.	1V or less	RS
20	Inhibitor "R" position switch	When selector lever is set to "R" position.	Battery voltage	BT
		When selector lever is set to other positions.	1V or less	HA
21	Wide open throttle position switch	When accelerator pedal is depressed more than half-way after warming up engine.	8 - 15V	EL
		When accelerator pedal is released after warming up engine.	1V or less	IDX
22	—	—	—	

\*: These terminals are connected to the ECM (ECCS control module).

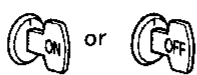
# TROUBLE DIAGNOSES



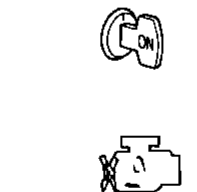



## Electrical Components Inspection (Cont'd)

Terminal No.	Item	Condition	Judgment standard	
23	Power source (Back-up)		When ignition switch is turned to "OFF".	Battery voltage
			When ignition switch is turned to "ON".	Battery voltage
24	Engine speed signal		When engine is running at idle speed.	0.9V
			When engine is running at 3,000 rpm.	Approximately 3.7V
25	Revolution sensor (Measure in AC position)		When vehicle is cruising at 30 km/h (19 MPH).	1V or more Voltage rises gradually in response to vehicle speed.
			When vehicle is parked.	0V
26	Turbine revolution sensor		When engine is running at 1,000 rpm	Approximately 1.2V Voltage rises gradually in response to engine speed.
27	Vehicle speed sensor		When vehicle is moving at 2 to 3 km/h (1 to 2 MPH) for 1 m (3 ft) or more.	Vary from 0 to 5V
28**	—	—	—	—
29**	—	—	—	—
30**	—	—	—	—
31	Throttle position sensor (Power source)		—	4.5 - 5.5V
32	—		—	—
33	Fluid temperature sensor		When ATF temperature is 20°C (68°F).	Approximately 1.5V
			When ATF temperature is 80°C (176°F).	Approximately 0.5V
34	Throttle position sensor		When accelerator pedal is depressed slowly after warming up engine. (Voltage rises gradually in response to throttle opening angle.)	Fully-closed throttle: Approximately 0.5V Fully-open throttle: Approximately 4V
35	Throttle position sensor (Ground)	—	—	
36	—	—	—	

\*\* : These terminals are connected to the data link connector for CONSULT.

# TROUBLE DIAGNOSES

## Electrical Components Inspection (Cont'd)

Terminal No.	Item	Condition		Judgment standard	
37	ASCD cruise signal		When ASCD cruise is being performed. ("CRUISE" light comes on.)	Battery voltage	GI
			When ASCD cruise is not being performed. ("CRUISE" light does not come on.)	1V or less	MA
38	—		—	—	
39	1 position switch		When selector lever is set to "1" position.	Battery voltage	EM
		When selector lever is set to other positions.	1V or less	LC	
40	ASCD, OD cut signal		When ASCD permits OD	5 - 8V	EF & EC
			When ASCD requires OD OFF	1V or less	
41	Kickdown switch		When accelerator pedal is released after warming up engine.	3 - 8V	FE
			When accelerator pedal is depressed fully after warming up engine.	1V or less	AT
42	—		—	—	PD
43	—		—	—	
44	—		—	—	FA
45	—		—	—	
46	—		—	—	RA
47☆	—		—	—	
48	Ground		—	—	BR

☆: This terminal is connected to the Active Suspension control unit.

GI

MA

EM

LC

EF &amp; EC

FE

AT

PD

FA

RA

BR

ST

RS

BT

HA

EL

IDX

# TROUBLE DIAGNOSES

## Electrical Components Inspection (Cont'd)

### INHIBITOR SWITCH

1. Check continuity between terminals ① and ② and between terminals ③ and ④, ⑤, ⑥, ⑦, ⑧, ⑨ while moving selector lever through each position.

Lever position	Continuity between terminal	
P	① — ②	③ — ④
R		③ — ⑤
N	① — ②	③ — ⑥
D		③ — ⑦
3		③ — ⑧
2, 1		③ — ⑨

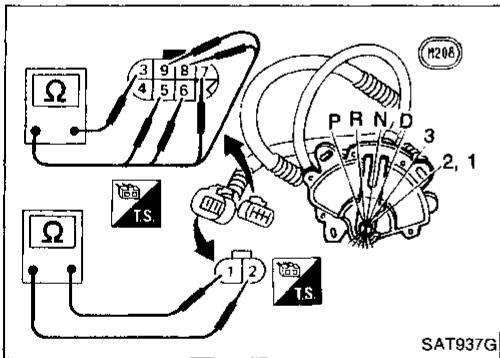
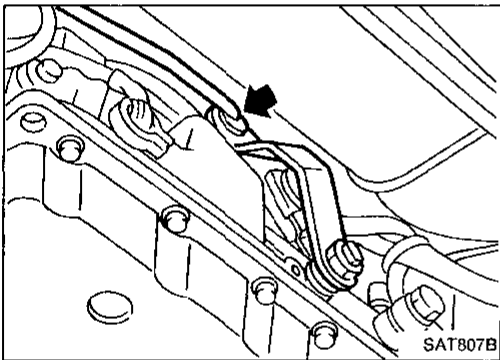
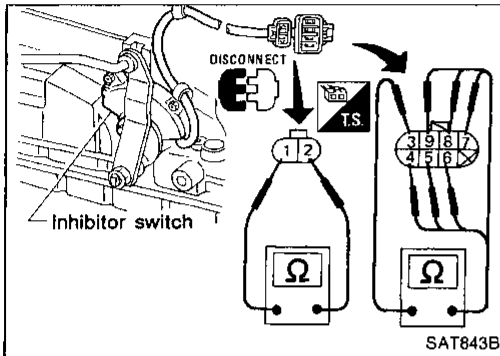
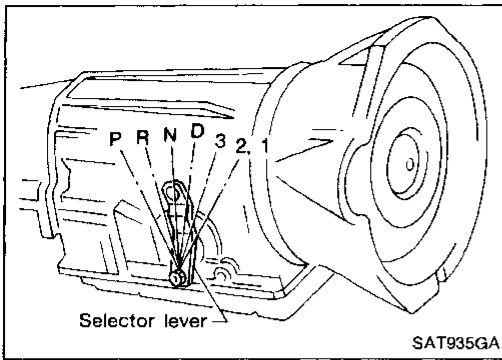

2. If N.G., check again with manual control linkage disconnected from manual shaft of A/T assembly. — Refer to step 1.
3. If O.K. on step 2, adjust manual control linkage. — Refer to "ON-VEHICLE SERVICE", AT-106.
4. If N.G. on step 2, remove inhibitor switch from A/T and check continuity of inhibitor switch terminal. — Refer to step 1.
5. If O.K. on step 4, adjust inhibitor switch. — Refer to "ON-VEHICLE SERVICE", AT-106.
6. If N.G. on step 4, replace inhibitor switch.



# TROUBLE DIAGNOSES

## Electrical Components Inspection (Cont'd)

### 1 POSITION SWITCH

- Check continuity between terminals ① and ② of 1 position switch harness connector.

Condition	Continuity
When selector lever is set in "1" position.	Yes
When selector lever is set in any position except "1".	No

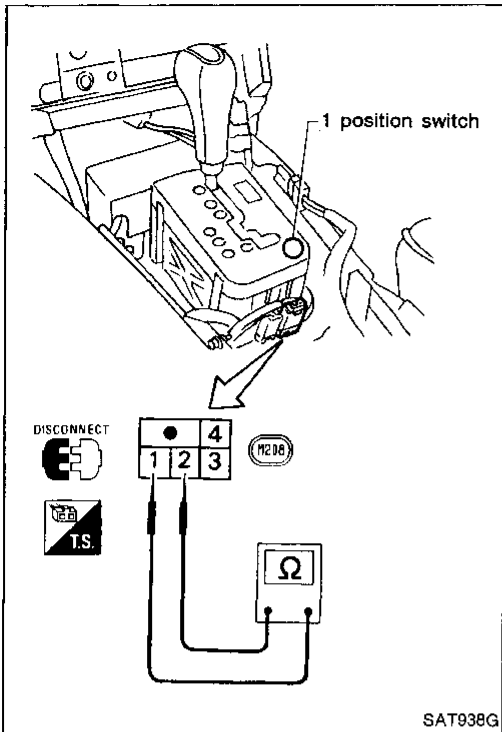

SAT938G

### REVOLUTION SENSOR

- For removal and installation, refer to "ON-VEHICLE SERVICE", AT-106.
- Check resistance between terminals ①, ② and ③.

Terminal No.		Resistance
①	②	500 - 650Ω
②	③	No continuity
①	③	No continuity

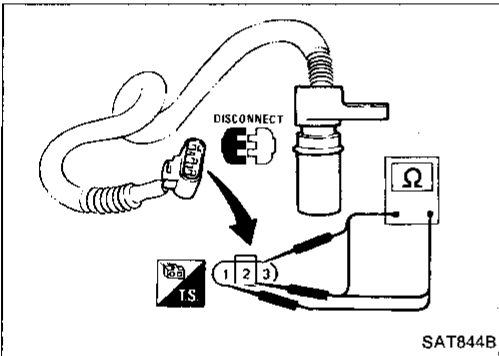

SAT844B

### TURBINE REVOLUTION SENSOR

- Check resistance between terminals ①, ② and ③.

Terminal No.		Resistance
①	②	2,200 - 2,800Ω
②	③	No continuity
①	③	No continuity

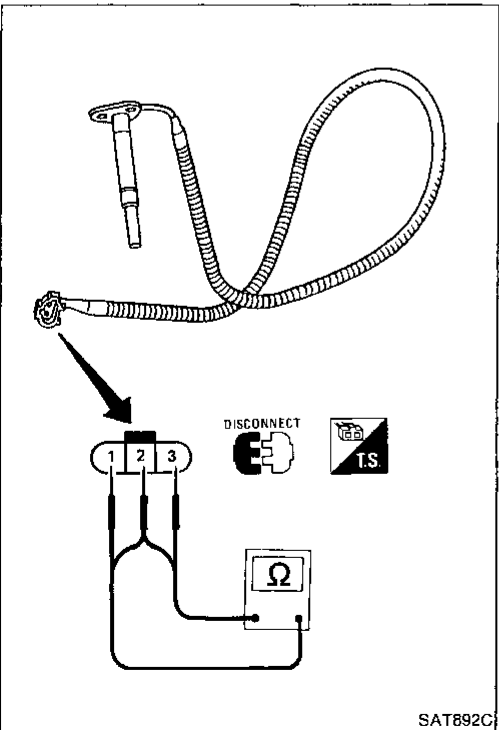

SAT892C

GI

MA

EM

LC

EF &  
EC

FE

AT

PD

FA

RA

BR

ST

RS

BT

HA

EL

IDX

## TROUBLE DIAGNOSES

### Electrical Components Inspection (Cont'd)

#### FLUID TEMPERATURE SENSOR

- For removal and installation, refer to "ON-VEHICLE SERVICE", AT-106.
- Check resistance between two terminals while changing temperature as shown at left.

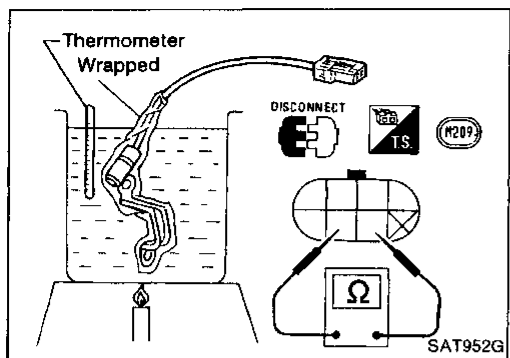

Temperature °C (°F)	Resistance
20 (68)	Approximately 2.5 kΩ
80 (176)	Approximately 0.3 kΩ

#### TORQUE CONVERTER CLUTCH SOLENOID VALVE

- For removal and installation, refer to "ON-VEHICLE SERVICE" AT-106.
- Check resistance between two terminals.  
**Resistance: 10 - 20Ω**

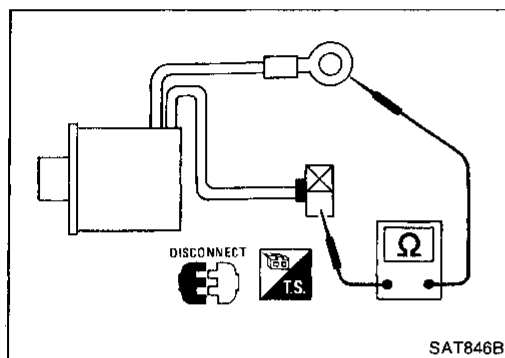

#### 3-UNIT SOLENOID ASSEMBLY (Shift solenoid valves A, B and overrun clutch solenoid valve) AND LINE PRESSURE SOLENOID VALVE

- For removal and installation, refer to "ON-VEHICLE SERVICE", AT-106.
- Check resistance between terminals of each solenoid.

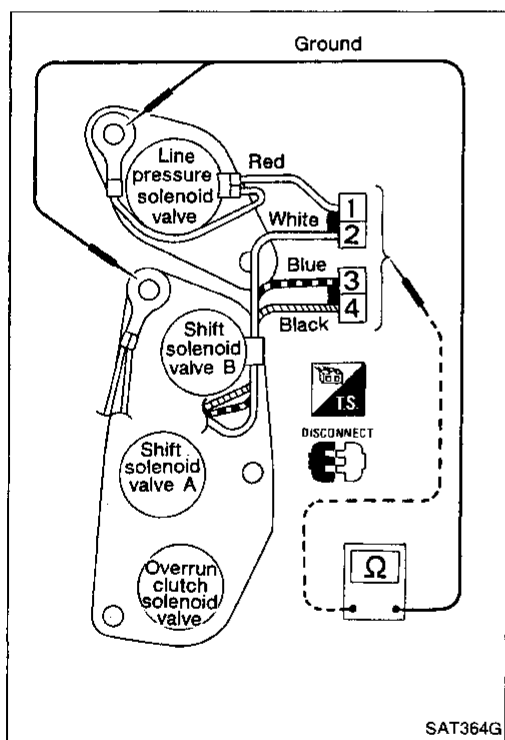

Solenoid	Terminal No.	Resistance
Shift solenoid valve A	③	20 - 40Ω
Shift solenoid valve B	②	
Overrun clutch solenoid valve	④	
Line pressure solenoid valve	①	2.5 - 5Ω

#### DROPPING RESISTOR

- Check resistance between two terminals.  
**Resistance: 11.2 - 12.8Ω**

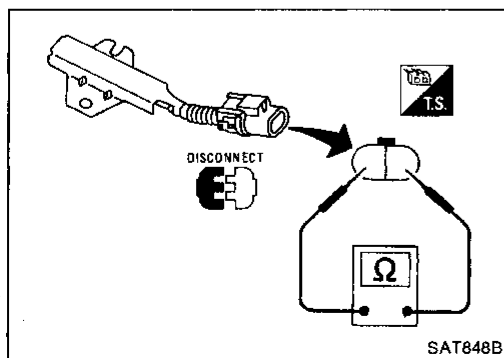

# TROUBLE DIAGNOSES

---

NOTE

GI

MA

EM

LC

EF &  
EC

FE

**AT**

PD

FA

RA

BR

ST

RS

BT

HA

EL

IDX

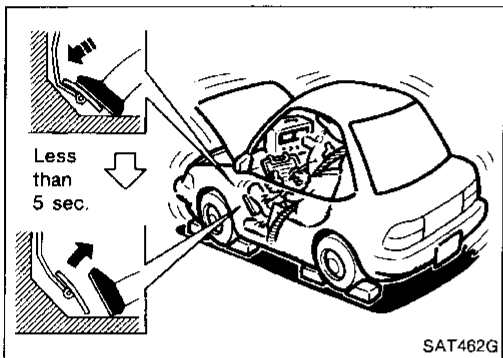
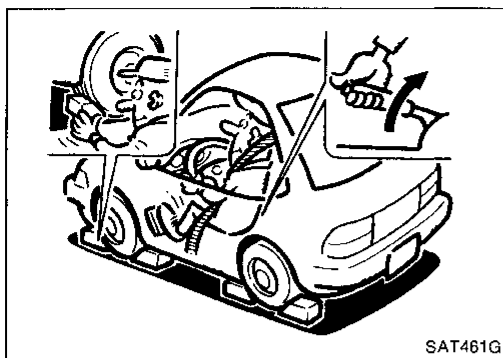

## Final Check

### STALL TESTING

#### Objects:

To check malfunctioning control elements of transmission, torque converter function and overall engine performance.

#### Stall test procedure

1. Check A/T and engine fluid levels. If necessary, add.
2. Drive vehicle for about 10 minutes until engine oil and ATF reach operating temperature.

**ATF operating temperature: 50 - 80°C (122 - 176°F)**

3. Set parking brake and block wheels.
4. Install a tachometer where it can be seen by driver.
- **It is good practice to put a mark on point of specified engine speed on indicator.**
5. Start engine, apply foot brake, and place selector lever in "D" position.
6. Accelerate to wide-open throttle gradually while applying foot brake.
7. Quickly note the engine stall revolution and immediately release throttle.
- **During test, never hold throttle wide-open for more than 5 seconds.**
- Stall revolution: 2,100 - 2,300 rpm**
8. Shift selector lever to "N".
9. Cool off ATF.
- **Run engine at idle for at least one minute.**
10. Repeat steps 5 through 9 with selector lever in "2", "1" and "R" positions.

### JUDGEMENT OF STALL TEST

The test result and possible damaged components relating to each result are shown in the illustration. In order to pinpoint the possible damaged components, follow the WORK FLOW shown in AT-13.

#### Note

#### Engine rpm is too high in "D" or "2" position:

- Slippage occurs in 1st gear but not in 2nd and 3rd gears. .... Low one-way clutch slippage
- Slippage occurs in 1st through 3rd gears in "D" position and engine brake functions with power shift switch set to "POWER", or slippage occurs in 1st and 2nd gears in "2" position and engine brake functions with accelerator pedal completely released (fully closed throttle). .... Forward clutch or forward one-way clutch slippage

#### Engine speed is too high in "R" position:

- Engine brake does not function in "1" position. .... Low & reverse brake slippage
- Engine brake functions in "1" position. .... Reverse clutch slippage

#### Stall revolution within specifications:

- Vehicle does not achieve speed of more than 80 km/h. .... One-way clutch seizure in torque converter housing

#### CAUTION:

#### Be careful since automatic fluid temperature increases abnormally.

- Slippage occurs in 3rd and 4th gears in "D" position. .... High clutch slippage
- Slippage occurs in 2nd and 4th gear in "D" position. .... Brake band slippage

#### Stall revolution less than specifications:

- Poor acceleration during starts. .... One-way clutch seizure in torque converter

# TROUBLE DIAGNOSES

## Final Check (Cont'd)

### Judgement of stall test

Selector lever position	Judgement		
D	L	O	H
3	L	O	H
2	L	O	H
1	L	O	O
R	L	H	H

- O : Stall revolution is normal.
- H : Stall revolution is higher than specified.
- L : Stall revolution is lower than specified.

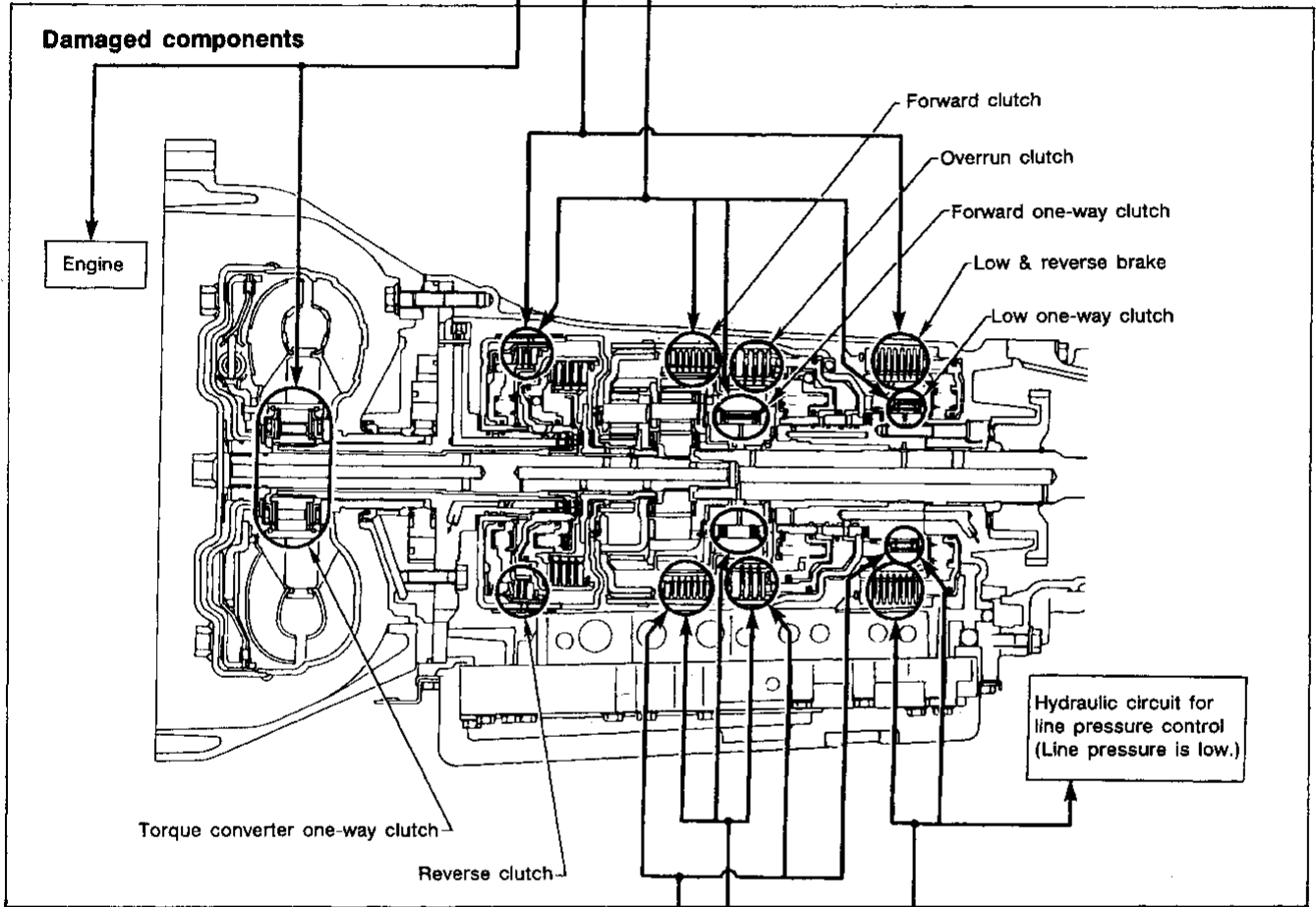

D	H	H	H	O
3	H	H	H	O
2	H	H	H	O
1	O	H	H	O
R	O	O	H	O
Selector lever position	Judgement			

GI

MA

EM

LC

EF &  
EC

FE

AT

PD

FA

RA

BR

ST

RS

BT

HA

EL

IDX

## TROUBLE DIAGNOSES

### Final Check (Cont'd)

#### PRESSURE TESTING

- Location of line pressure test port
- Line pressure plugs are hexagon headed bolts.
- Always replace line pressure plugs as they are self-sealing bolts.

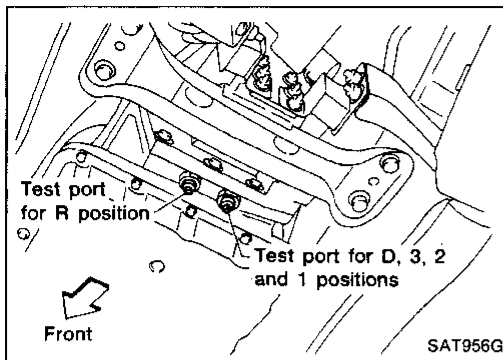

#### Line pressure test procedure

1. Check A/T and engine fluid levels. If necessary, add.
2. Drive vehicle for about 10 minutes until engine oil and ATF reach operating temperature.

**ATF operating temperature:**

**50 - 80°C (122 - 176°F)**

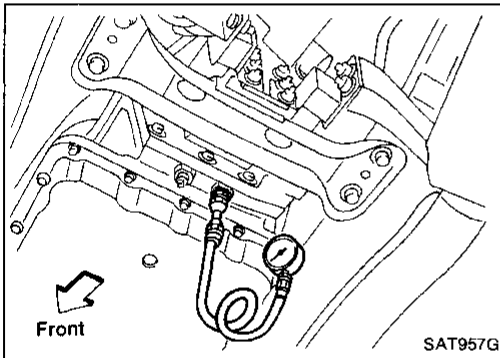

3. Install pressure gauge to line pressure port.  
— D, 3, 2 and 1 positions —

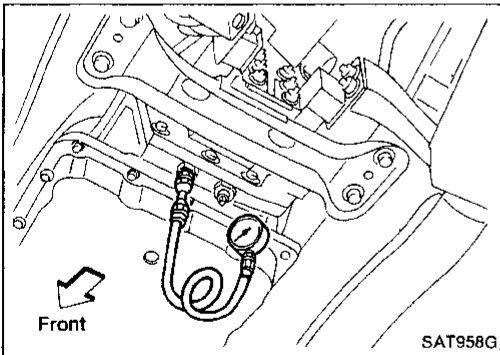

— R position —

4. Set parking brake and block wheels.
  - Continue to depress brake pedal fully while line pressure test at stall speed is performed.

## TROUBLE DIAGNOSES

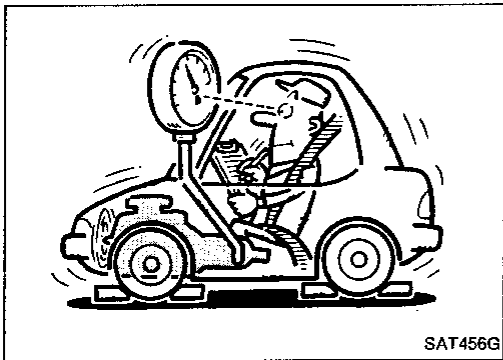

### Final Check (Cont'd)

5. Start engine and measure line pressure at idle and stall speed.
  - When measuring line pressure at stall speed, follow the stall test procedure.

#### Line pressure:

Engine speed rpm	Line pressure kPa (kg/cm <sup>2</sup> , psi)	
	D, 3, 2 and 1 positions	R position
Idle	451 - 490 (4.6 - 5.0, 65 - 71)	628 - 667 (6.4 - 6.8, 91 - 97)
Stall	1,020 - 1,098 (10.4 - 11.2, 148 - 159)	1,422 - 1,510 (14.5 - 15.4, 206 - 219)

GI

MA

EM

LC

EF &  
EC

FE

AT

PD

FA

RA

BR

ST

RS

BT

HA

EL

IDX

### JUDGMENT OF LINE PRESSURE TEST

Judgment		Suspected parts
At idle	Line pressure is low in all positions.	<ul style="list-style-type: none"> <li>● Oil pump wear</li> <li>● Control piston damage</li> <li>● Pressure regulator valve or plug sticking</li> <li>● Spring for pressure regulator valve damaged</li> <li>● Fluid pressure leakage between oil strainer and pressure regulator valve</li> </ul>
	Line pressure is low in particular position.	<ul style="list-style-type: none"> <li>● Fluid pressure leakage between manual valve and particular clutch.</li> <li>● For example, line pressure is: Low in "R" and "1" positions, but Normal in "D", "3" and "2" positions. Then, fluid leakage exists at or around low and reverse brake circuit.</li> </ul>
	Line pressure is high.	<ul style="list-style-type: none"> <li>● Mal-adjustment of throttle position sensor</li> <li>● Fluid temperature sensor damaged</li> <li>● Line pressure solenoid valve sticking</li> <li>● Short circuit of line pressure solenoid valve circuit</li> <li>● Pressure modifier valve sticking</li> <li>● Pressure regulator valve or plug sticking</li> </ul>
At stall speed	Line pressure is low.	<ul style="list-style-type: none"> <li>● Mal-adjustment of throttle position sensor</li> <li>● Control piston damaged</li> <li>● Line pressure solenoid valve sticking</li> <li>● Short circuit of line pressure solenoid valve circuit</li> <li>● Pressure regulator valve or plug sticking</li> <li>● Pressure modifier valve sticking</li> <li>● Pilot valve sticking</li> </ul>

# TROUBLE DIAGNOSES

## Symptom Chart

Reference page (AT- )		ON vehicle										OFF vehicle																								
		21, 108	80,81	81	87	82, 132	82	82	82, 106	106	106	116, 128	146, 150	152, 162	152, 160	120, 156	81, 168																			
Reference page (AT- )	Numbers are arranged in order of probability. Perform inspections starting with number one and work up. Circled numbers indicate that the transmission must be removed from the vehicle.	Fluid level	Control linkage	Inhibitor switch and 1 position switch	Throttle position sensor (Adjustment)	Revolution sensor and vehicle speed sensor	Engine speed signal	Engine idling speed	Line pressure	Control valve assembly	Shift solenoid valve A	Shift solenoid valve B	Line pressure solenoid valve	Torque converter clutch solenoid valve	Overrun clutch solenoid valve	Fluid temperature sensor	Accumulator N-D	Accumulator 1-2	Accumulator 2-3	Accumulator 3-4 (N-R)	Ignition switch and starter	Torque converter	Oil pump	Reverse clutch	High clutch	Forward clutch	Forward one-way clutch	Overrun clutch	Low one-way clutch	Low & reverse brake	Brake band	Turbine revolution sensor	Parking components			
59	Engine does not start in "N", "P" positions.	2	3																	1																
59	Engine starts in position other than "N" and "P".	1	2																																	
—	Transmission noise in "P" and "N" positions.	1	3	4	5	2															7	6														
59	Vehicle moves when changing into "P" position or parking gear does not disengage when shifted out of "P" position.	1																																2		
60	Vehicle runs in "N" position.	1																		4				3		2		5								
62	Vehicle will not run in "R" position (but runs in "D", "3", "2" and "1" positions). Clutch slips. Very poor acceleration.	1				2	4					3												5	6	7		8		9						
—	Vehicle braked when shifting into "R" position.	1	2			3	5				4														6	8		9			7					
—	Sharp shock in shifting from "N" to "D" position.			2	5	1	3	7			6			4	8											10						9				
—	Vehicle will not run in "D", "3" and "2" positions (but runs in "1" and "R" position).	1																										2								
63	Vehicle will not run in "D", "1", "2" and "3" positions (but runs in "R" position). Clutch slips. Very poor acceleration.	1				2	4				3					5									6	7	8	9		10						
—	Clutches or brakes slip somewhat in starting.	1	2	3		4	6			5						7				8			13	12	10		9				11					
—	Excessive creep.					1																														
62 - 63	No creep at all.	1				2	3																	6	5		4									
—	Failure to change gear from "D <sub>1</sub> " to "D <sub>2</sub> ".	2	1	5		4	3																										5			
—	Failure to change gear from "D <sub>2</sub> " to "D <sub>3</sub> ".	2	1	5		4	3																		6							7				
—	Failure to change gear from "D <sub>3</sub> " to "D <sub>4</sub> ".	2	1	4		3							5																				6			
65 - 67	Too high a gear change point from "D <sub>1</sub> " to "D <sub>2</sub> ", from "D <sub>2</sub> " to "D <sub>3</sub> ", from "D <sub>3</sub> " to "D <sub>4</sub> ".		1	2						3	4																									
—	Gear change directly from "D <sub>1</sub> " to "D <sub>3</sub> " occurs.	1															2															3				
—	Engine stops when shifting lever into "R", "D", "3", "2" and "1".					1	3					2										4														
—	Too sharp a shock in change from "D <sub>1</sub> " to "D <sub>2</sub> ".		1			2	4							5	3																		6			
—	Too sharp a shock in change from "D <sub>2</sub> " to "D <sub>3</sub> ".		1			2	4													3													6			



# TROUBLE DIAGNOSES

## Symptom Chart (Cont'd)

Reference page (AT- )		ON vehicle										OFF vehicle																								
		21, 108	80, 81	81	87	82, 132	82	82	82, 106	106	106	116, 128	146, 150	152, 162	152, 160	120, 156	81, 168																			
Reference page (AT- )	Numbers are arranged in order of probability. Perform inspections starting with number one and work up. Circled numbers indicate that the transmission must be removed from the vehicle.	Fluid level	Control linkage	Inhibitor switch and 1 position switch	Throttle position sensor (Adjustment)	Revolution sensor and vehicle speed sensor	Engine speed signal	Engine idling speed	Line pressure	Control valve assembly	Shift solenoid valve A	Shift solenoid valve B	Line pressure solenoid valve	Torque converter clutch solenoid valve	Overrun clutch solenoid valve	Fluid temperature sensor	Accumulator N-D	Accumulator 1-2	Accumulator 2-3	Accumulator 3-4 (N-R)	Ignition switch and starter	Torque converter	Oil pump	Reverse clutch	High clutch	Forward clutch	Forward one-way clutch	Overrun clutch	Low one-way clutch	Low & reverse brake	Brake band	Turbine revolution sensor	Parking components			
—	Too sharp a shock in change from "D <sub>3</sub> " to "D <sub>4</sub> ".			1			2		4											3																
—	Almost no shock or clutches slipping in change from "D <sub>1</sub> " to "D <sub>2</sub> ".	1		2			3		5									4																		
—	Almost no shock or slipping in change from "D <sub>2</sub> " to "D <sub>3</sub> ".	1		2			3		5										4																	
—	Almost no shock or slipping in change from "D <sub>3</sub> " to "D <sub>4</sub> ".	1		2			3		5											4																
—	Vehicle braked by gear change from "D <sub>1</sub> " to "D <sub>2</sub> ".	1																						2	4					5	3					
—	Vehicle braked by gear change from "D <sub>2</sub> " to "D <sub>3</sub> ".	1																																		
—	Vehicle braked by gear change from "D <sub>3</sub> " to "D <sub>4</sub> ".	1																						4												
—	Maximum speed not attained. Acceleration poor.	1	2						5	3	4												11	10	6	7					9	8				
—	Failure to change gear from "D <sub>4</sub> " to "D <sub>3</sub> ".	1		2					6	4		5		3																						
—	Failure to change gear from "D <sub>3</sub> " to "D <sub>2</sub> " or from "D <sub>4</sub> " to "D <sub>2</sub> ".	1		2					5	3	4														6											
—	Failure to change gear from "D <sub>2</sub> " to "D <sub>1</sub> " or from "D <sub>3</sub> " to "D <sub>1</sub> ".	1		2					5	3	4														7											
—	Gear change shock felt during deceleration by releasing accelerator pedal.			1			2		4					3																						
—	Too high a change point from "D <sub>4</sub> " to "D <sub>3</sub> ", from "D <sub>3</sub> " to "D <sub>2</sub> ", from "D <sub>2</sub> " to "D <sub>1</sub> ".			1	2																															
—	Kickdown does not operate when depressing pedal in "D <sub>4</sub> " within kickdown vehicle speed.			1	2						3	4																								
—	Kickdown operates or engine overruns when depressing pedal in "D <sub>4</sub> " beyond kickdown vehicle speed limit.			2	1						3	4																								
—	Races extremely fast or slips in changing from "D <sub>4</sub> " to "D <sub>3</sub> " when depressing pedal.	1		2				3	5			4													6	7										
—	Races extremely fast or slips in changing from "D <sub>4</sub> " to "D <sub>2</sub> " when depressing pedal.	1		2				3	6	5		4														8										
—	Races extremely fast or slips in changing from "D <sub>3</sub> " to "D <sub>2</sub> " when depressing pedal.	1		2				3	5			4				8		10								9	7									
—	Races extremely fast or slips in changing from "D <sub>4</sub> " or "D <sub>3</sub> " to "D <sub>1</sub> " when depressing pedal.	1		2				3	5			4															6	7								
—	Vehicle will not run in any position.	1	2					3				4												3	5		6						8	7		10
—	Transmission noise in "D", "3", "2", "1" and "R" positions.	1																					2													

GI  
 MA  
 EM  
 LC  
 EF & EC  
 FE  
**AT**  
 PD  
 FA  
 RA  
 BR  
 ST  
 RS  
 BT  
 HA  
 EL  
 IDX

# TROUBLE DIAGNOSES

## Symptom Chart (Cont'd)

Reference page (AT- )	Reference page (AT- )	ON vehicle										OFF vehicle																						
		21, 108	80, 81	81	87	82, 132	82	82	82, 106	106	106	116, 128	146, 150	152, 162	152, 160	120, 156	81, 168																	
	Numbers are arranged in order of probability. Perform inspections starting with number one and work up. Circled numbers indicate that the transmission must be removed from the vehicle.	Fluid level	Control linkage	Inhibitor switch and 1 position switch	Throttle position sensor (Adjustment)	Revolution sensor and vehicle speed sensor	Engine speed signal	Engine idling speed	Line pressure	Control valve assembly	Shift solenoid valve A	Shift solenoid valve B	Line pressure solenoid valve	Torque converter clutch solenoid valve	Overrun clutch solenoid valve	Fluid temperature sensor	Accumulator N-D	Accumulator 1-2	Accumulator 2-3	Accumulator 3-4 (N-R)	Ignition switch and starter	Torque converter	Oil pump	Reverse clutch	High clutch	Forward clutch	Forward one-way clutch	Overrun clutch	Low one-way clutch	Low & reverse brake	Brake band	Turbine revolution sensor	Parking components	
74	Failure to change from "3 <sub>3</sub> " to "2 <sub>2</sub> " then changing lever into "2" position.	7	1	2					6	5	4		3																					
—	Gear change from "2 <sub>2</sub> " to "2 <sub>3</sub> " in "2" position.		1																															
75	Engine brake does not operate in "1" position.	2	1	3	4				6	5			7																					
—	Gear change from "1 <sub>1</sub> " to "1 <sub>2</sub> " in "1" position.	2	1																															
—	Does not change from "1 <sub>2</sub> " to "1 <sub>1</sub> " in "1" position.		1		2				4	3			5																					
—	Large shock changing from "1 <sub>2</sub> " to "1 <sub>1</sub> " in "1" position.								1																									
—	Transmission overheats.	1		3		2	4	6		5												14	7	8	9	11	12		13	10				
—	A.T.F. shoots out during operation. White smoke emitted from exhaust pipe during operation.	1																					2	3	5	6		7	4					
—	Offensive smell at fluid charging pipe.	1																				2	3	4	5	7	8		9	6				
—	Torque converter is not locked up.		3	1	2	4		6	8			7	5									9												
—	Lock-up piston slip	1		2			3	6		5	4											7												
68	Lock-up point is extremely high or low.			1	2				4			3																						
—	A/T does not shift to "D <sub>4</sub> " when driving with selector lever set in D position.		2	1	3		8	6	4			5	7															10		9				
—	Engine is stopped at "R", "D", "3", "2" and "1" positions.	1						5	4	3	2																							

**Contents**

<b>Shift Lock Electrical Parts Location .....</b>	<b>AT- 92</b>	
<b>Circuit Diagram for Quick Pinpoint Check .....</b>	<b>AT- 93</b>	
<b>Wiring Diagram .....</b>	<b>AT- 94</b>	<b>GI</b>
<b>Diagnostic Procedure 1 .....</b>	<b>AT- 95</b>	
SYMPTOM: Selector lever cannot be moved from "P" position when applying brake pedal. It can be moved when releasing brake pedal.		<b>MA</b>
Selector lever can be moved from "P" position when key is removed from key cylinder.		
<b>Diagnostic Procedure 2 .....</b>	<b>AT- 99</b>	<b>EM</b>
SYMPTOM: Ignition key cannot be removed when selector lever is set to "P" position. It can be removed when selector lever is set to any position except "P".		
<b>Shift Lock Control Unit Inspection .....</b>	<b>AT-103</b>	<b>LC</b>
<b>Shift Lock Control Unit Inspection Table .....</b>	<b>AT-103</b>	
<b>Component Check .....</b>	<b>AT-104</b>	<b>EF &amp; EC</b>

**FE**

**AT**

**PD**

**FA**

**RA**

**BR**

**ST**

**RS**

**BT**

**HA**

**EL**

**IDX**

**Shift Lock Electrical Parts Location**

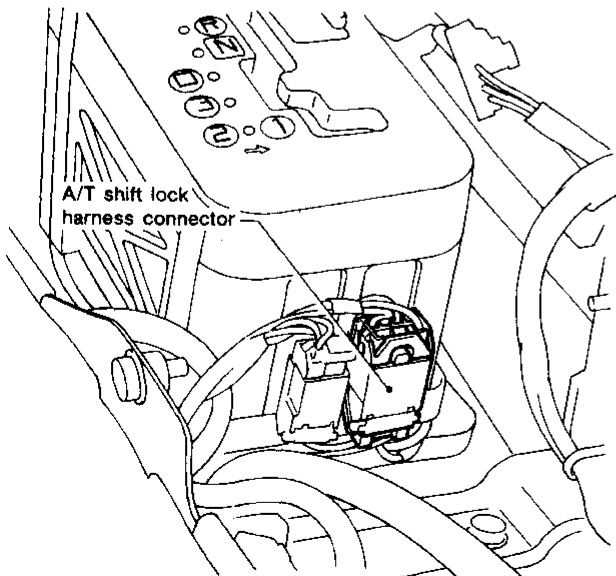
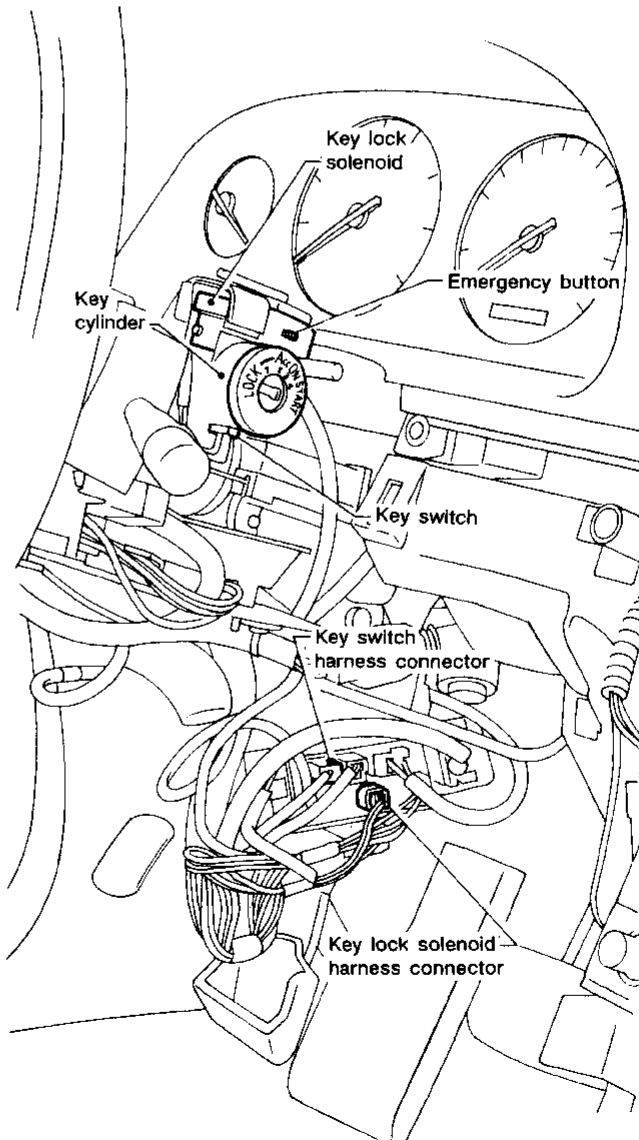
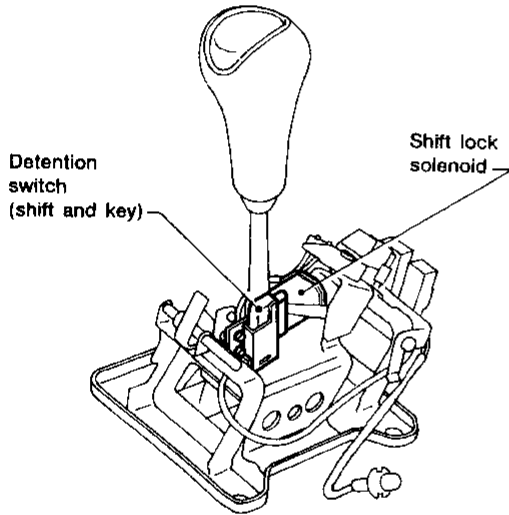
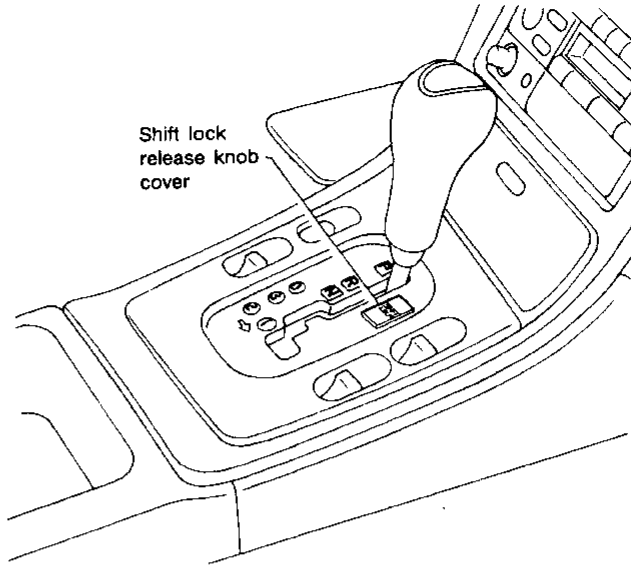
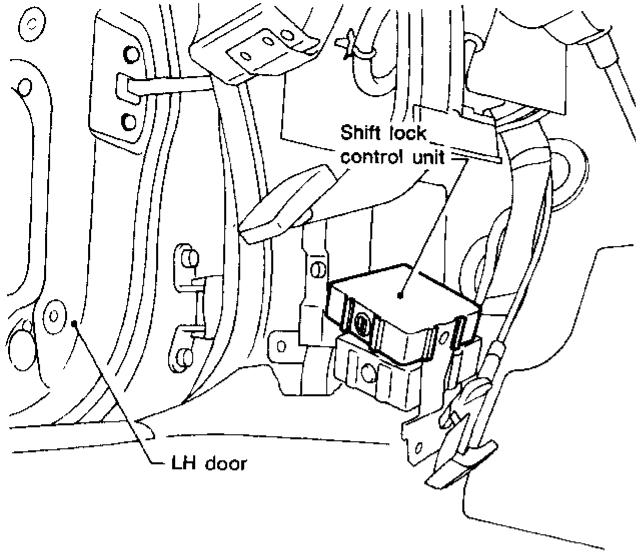

Circuit Diagram for Quick Pinpoint Check

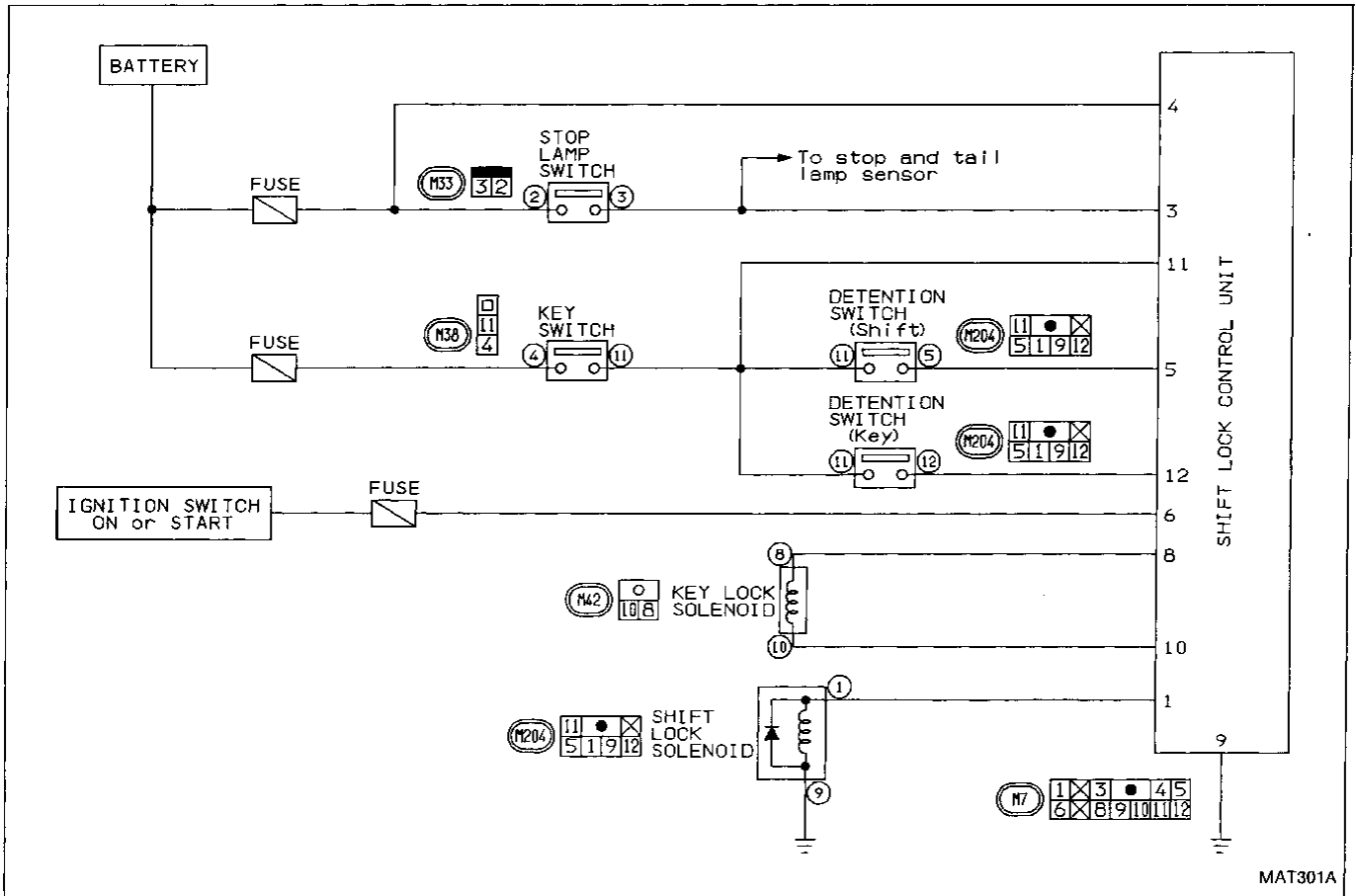

GI  
MA  
EM  
LC  
EF &  
EC  
FE  
AT  
PD  
FA  
RA  
BR  
ST  
RS  
BT  
HA  
EL  
IDX

Wiring Diagram

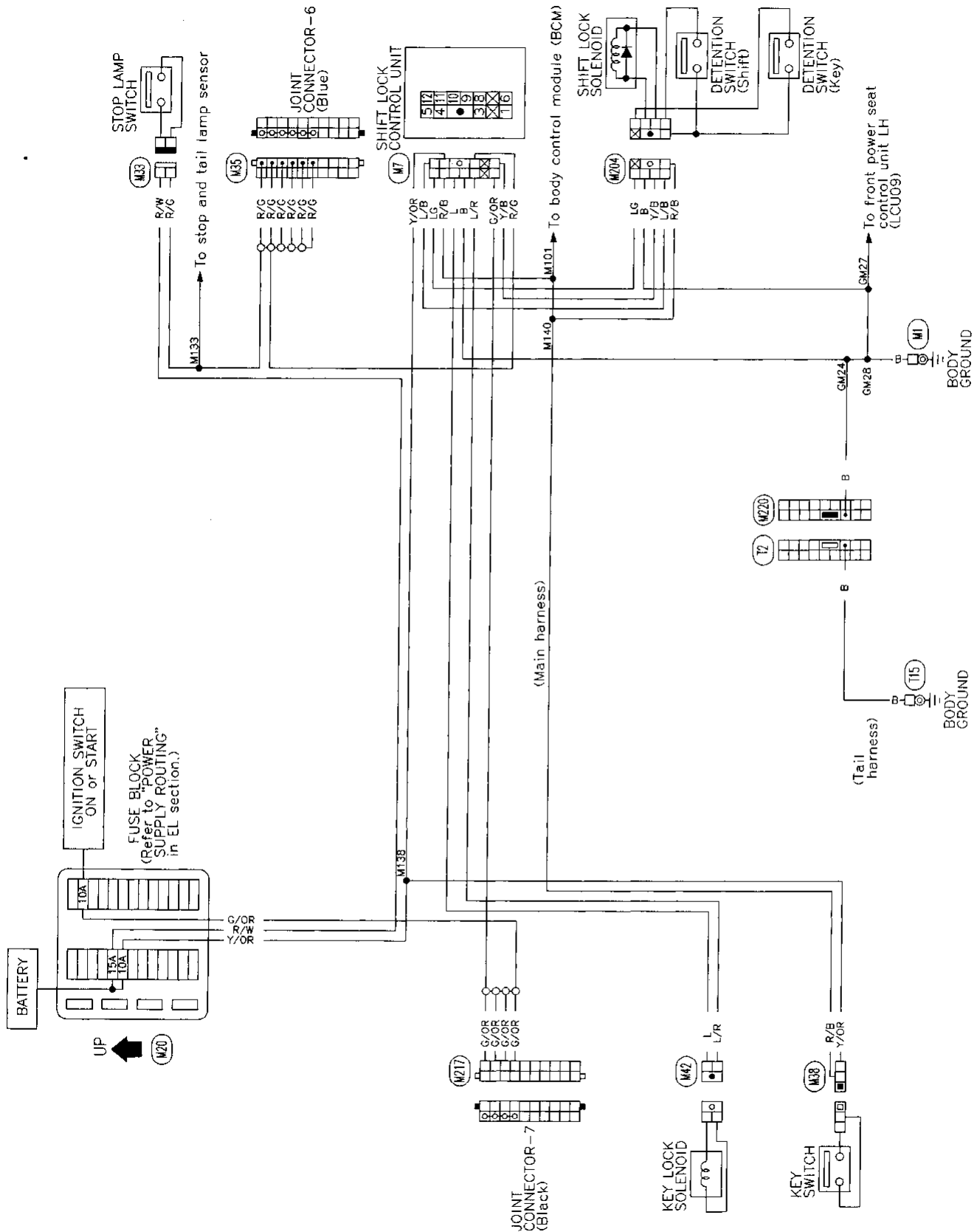

## Diagnostic Procedure 1

### SYMPTOM:

Selector lever cannot be moved from "P" position when applying brake pedal. It can be moved when releasing brake pedal. Selector lever can be moved from "P" position when key is removed from key cylinder.

GI  
MA  
EM  
LC  
EF & EC  
FE  
AT  
PD  
FA  
RA  
BR  
ST  
RS  
BT  
HA  
EL  
IDX

**1**

**CHECK POWER SOURCE.**  
1. Turn ignition switch to "OFF" position.  
2. Check voltage between control unit harness terminal ④ and ground.  
**Battery voltage should exist.**

NG → Check the following items:  
1. Harness continuity between battery and control unit harness terminal ④  
2. Fuse

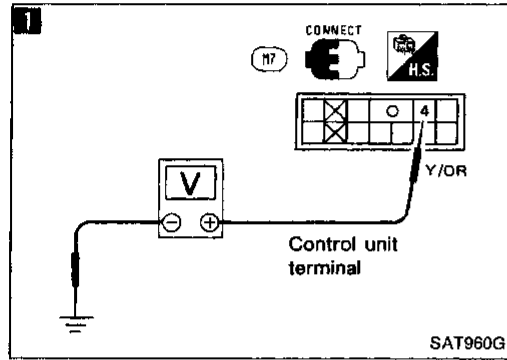

**2**

**CHECK IGNITION SIGNAL.**  
1. Turn ignition switch to "OFF" position.  
2. Check voltage between control unit harness terminal ⑥ and ground.  
**0V**  
3. Turn ignition switch from "OFF" to "ON" position. (Do not start engine.)  
4. Check voltage between control unit harness terminal ⑥ and ground.  
**Battery voltage should exist.**

NG → Check the following items:  
1. Harness continuity between battery and control unit harness terminal ⑥  
2. Fuse  
3. Ignition switch

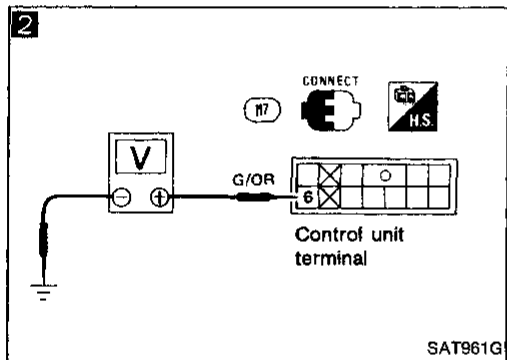

**3**

**CHECK GROUND CIRCUIT FOR CONTROL UNIT.**  
1. Turn ignition switch from "ON" to "OFF" position.  
2. Disconnect control unit harness connector.  
3. Check continuity between control unit harness terminal ⑨ and ground.  
**Continuity should exist.**

NG → Repair harness or connector.

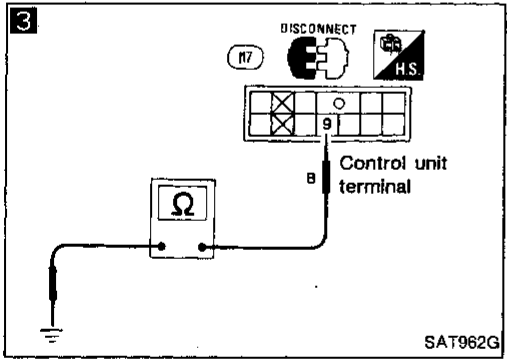

Ⓐ

# TROUBLE DIAGNOSES — A/T Shift Lock System

## Diagnostic Procedure 1 (Cont'd)

Ⓐ

4

### CHECK INPUT SIGNAL (KEY SWITCH).

1. Reconnect control unit harness connector.
  2. Remove key from ignition switch.
  3. Check voltage between control unit terminal ① and ground.
- 0V

NG

Check key switch.  
(Refer to "COMPONENT CHECK", AT-104.)

OK

5

1. Insert key into ignition switch.
2. Check voltage between control unit harness terminal ① and ground.  
**Battery voltage should exist.**

NG

Check the following items:

1. Harness continuity between control unit harness terminal ① and key switch harness terminal ①.
2. Harness continuity between key switch harness terminal ④ and fuse
3. Key switch (Refer to "COMPONENT CHECK", AT-104.)

OK

6 7

### CHECK INPUT SIGNAL (DETENTION SWITCH-SHIFT).

1. Turn ignition switch from "OFF" to "ON" position  
(Do not start engine.)
  2. Set selector lever in "P" position and release selector lever button.
  3. Check voltage between control unit harness terminal ⑤ and ground.
- 0V

NG

Check detention switch - shift.  
(Refer to "COMPONENT CHECK", AT-104.)

OK

Ⓑ

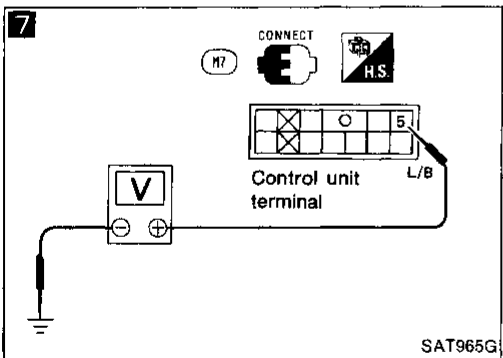
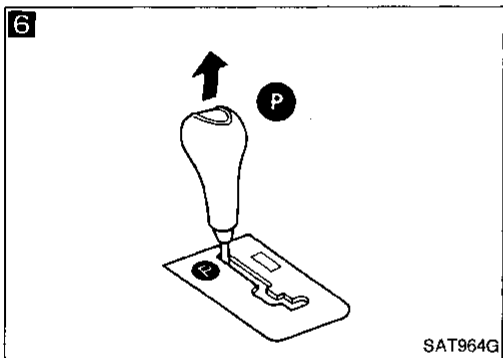
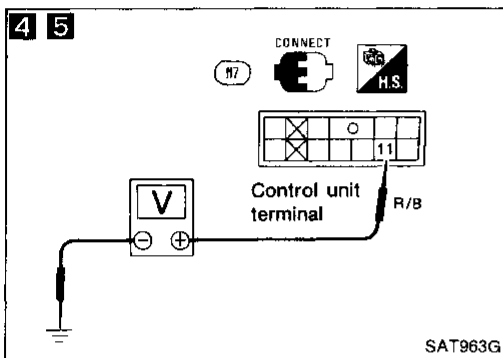



# TROUBLE DIAGNOSES — A/T Shift Lock System

## Diagnostic Procedure 1 (Cont'd)

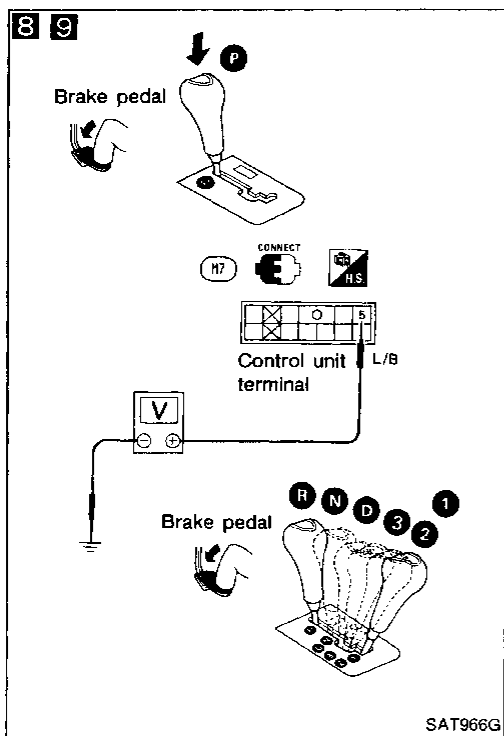

8 9

### CHECK INPUT SIGNAL (DETECTION SWITCH-SHIFT).

1. Turn ignition switch to "ON" position. (Do not start engine.)
2. Depress brake pedal. Push selector lever button. Check voltage between control unit harness terminal ⑤ and ground.

**Battery voltage should exist.**

3. Set selector lever in any position except "P". Check voltage between control unit harness terminal ⑤ and ground.

**When selector lever cannot be moved from "P" position with brake pedal depressed, push shift lock release knob. (Remove shift lock release knob cover.)**

**Battery voltage should exist.**

NG

Check the following items:

1. Harness continuity between control unit harness terminal ⑤ and detention switch harness terminal ⑤
2. Harness continuity between detention switch harness terminal 1 and key switch harness terminal ⑪
3. Detention switch - shift (Refer to "COMPONENT CHECK", AT-104.)

GI

MA

EM

LC

EF & EC

FE

AT

PD

FA

RA

BR

ST

RS

BT

HA

EL

IDX

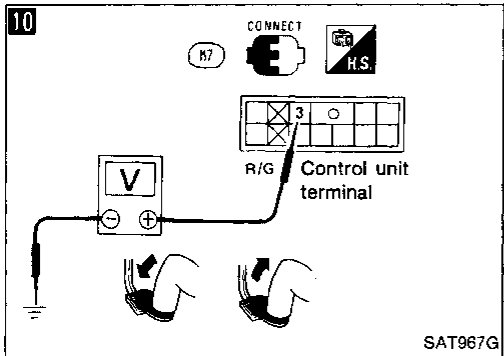

10

### CHECK INPUT SIGNAL (STOP LAMP SWITCH).

Turn ignition switch to "ON" position. (Do not start engine.)

- Check voltage between control unit harness terminal ③ and ground.

Brake pedal	Voltage
Depressed	Battery voltage
Released	0V

NG

Check the following items:

1. Harness continuity between control unit harness terminal ③ and stop lamp switch harness terminal ③
2. Harness continuity between stop lamp switch harness terminal ② and fuse
3. Stop lamp switch (Refer to "COMPONENT CHECK", AT-104.)

OK

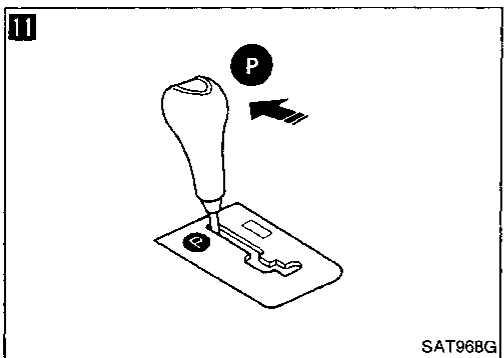

11

Set selector lever in "P" position.

Ⓒ

# TROUBLE DIAGNOSES — A/T Shift Lock System

## Diagnostic Procedure 1 (Cont'd)

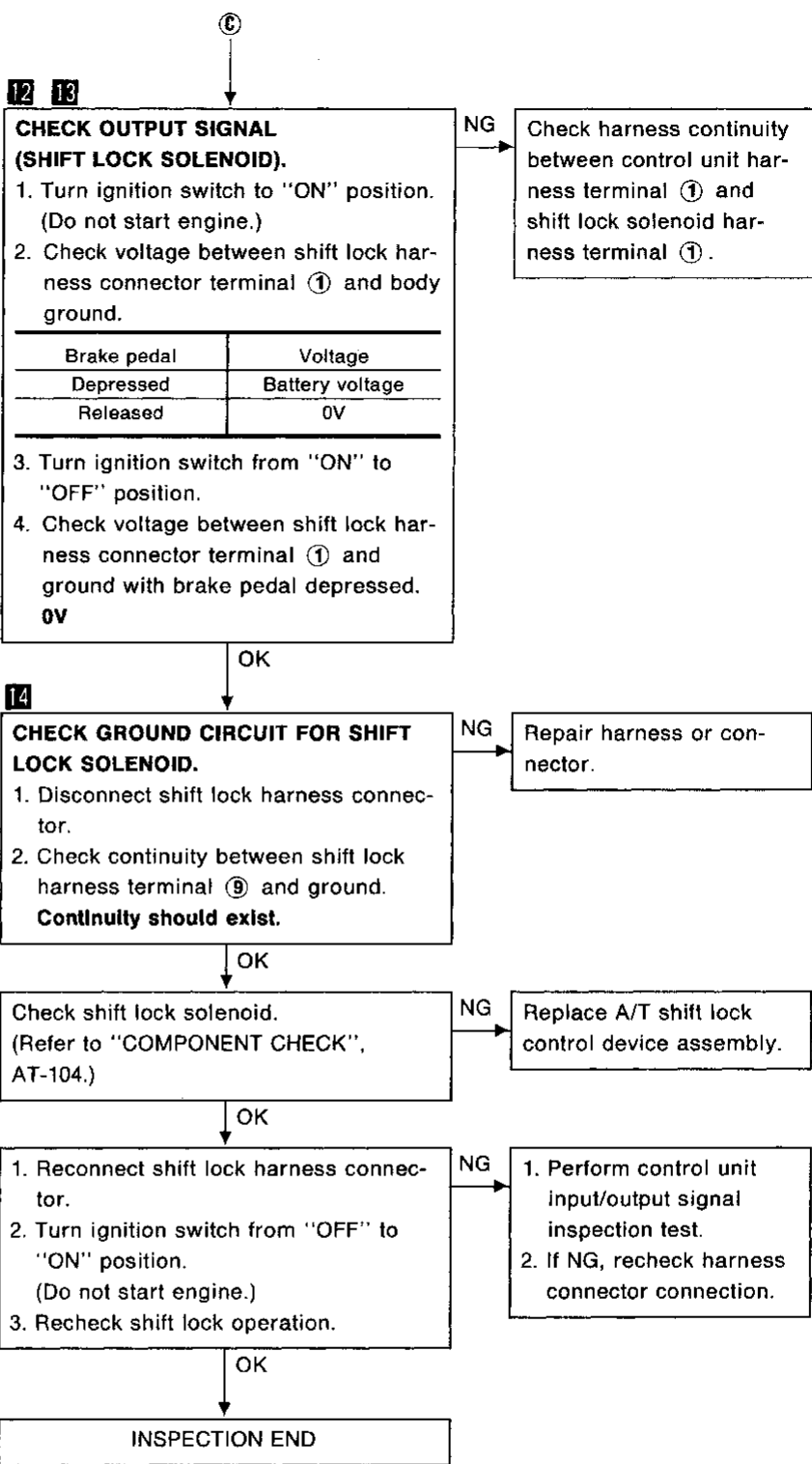
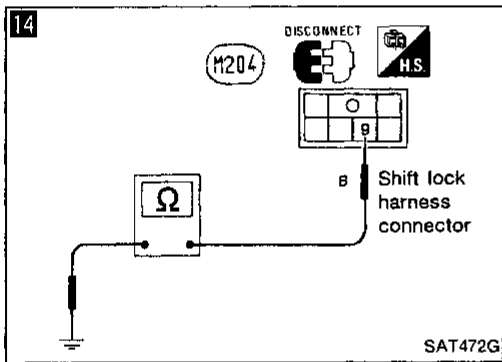
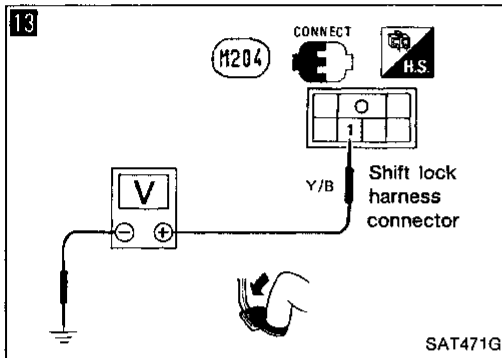
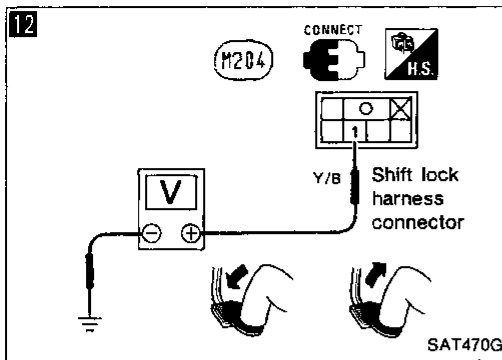

**Diagnostic Procedure 2**

**SYMPTOM:**

Ignition key cannot be removed when selector lever is set to "P" position. It can be removed when selector lever is set to any position except "P".

GI  
MA  
EM  
LC  
EF & EC  
FE  
AT  
PD  
FA  
RA  
BR  
ST  
RS  
BT  
HA  
EL  
IDX

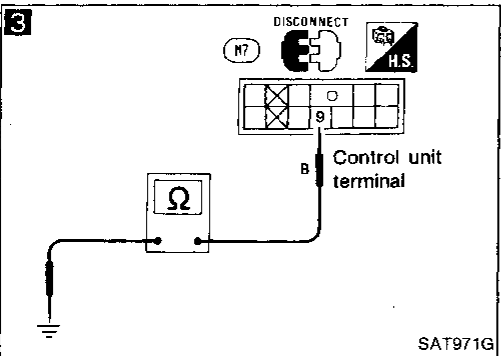
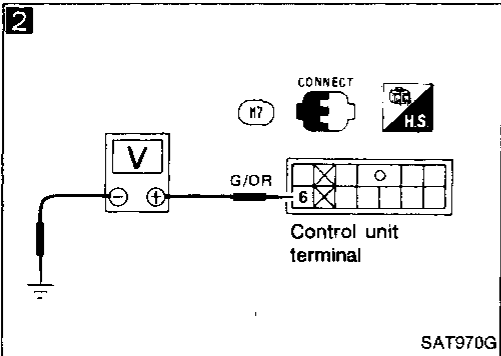
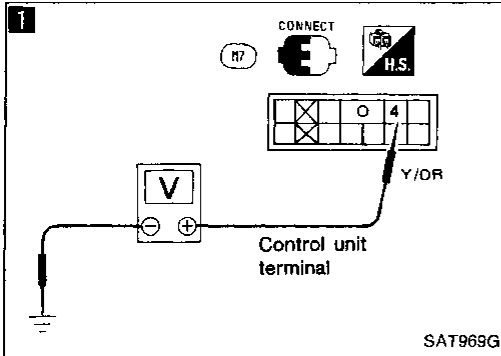

**1**

**CHECK POWER SOURCE.**  
1. Turn ignition switch to "OFF" position.  
2. Check voltage between control unit harness terminal ④ and ground.  
**Battery voltage should exist.**

NG → Check the following items:  
1. Harness continuity between battery and control unit harness terminal ④  
2. Fuse

**2**

**CHECK IGNITION SIGNAL.**  
1. Turn ignition switch to "OFF" position.  
2. Check voltage between control unit harness terminal ⑥ and ground.  
**0V**  
3. Turn ignition switch "OFF" to "ON" position. (Do not start engine.)  
4. Check voltage between control unit harness terminal ⑥ and ground.  
**Battery voltage should exist.**

NG → Check the following items:  
1. Harness continuity between battery and control unit harness terminal ⑥  
2. Fuse  
3. Ignition switch

**3**

**CHECK GROUND CIRCUIT FOR CONTROL UNIT.**  
1. Turn ignition switch from "ON" to "OFF" position.  
2. Disconnect control unit harness connector.  
3. Check continuity between control unit harness terminal ⑨ and ground.  
**Continuity should exist.**

NG → Repair harness or connector.

OK → (A)

# TROUBLE DIAGNOSES — A/T Shift Lock System

## Diagnostic Procedure 2 (Cont'd)

Ⓐ

4

### CHECK INPUT SIGNAL (KEY SWITCH).

1. Reconnect control unit harness connector.
2. Remove key from ignition switch.  
**When ignition key cannot be removed, even if selector lever is in "P" position, use emergency button.**
3. Check voltage between control unit terminal ⑪ and ground.  
**0V**

NG

Check key switch.  
(Refer to "COMPONENT CHECK", AT-104.)

OK

5

1. Insert key into ignition switch.
2. Check voltage between control unit harness terminal ⑪ and ground.  
**Battery voltage should exist.**

NG

Check the following items:

1. Harness continuity between control unit harness terminal ⑪ and key switch harness terminal ⑪.
2. Harness continuity between key switch harness terminal ④ and fuse
3. Key switch (Refer to "COMPONENT CHECK", AT-104.)

OK

6 7

### CHECK INPUT SIGNAL (DETENTION SWITCH - KEY).

1. Turn ignition switch from "OFF" to "ON" position.  
(Do not start engine.)
2. Set selector lever in "P" position and release selector lever button.
3. Check voltage between control unit harness terminal ⑫ and ground.  
**0V**

NG

Check detention switch - key.  
(Refer to "COMPONENT CHECK", AT-104.)

OK

Ⓑ

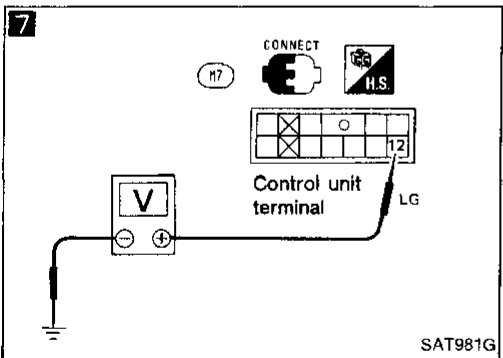
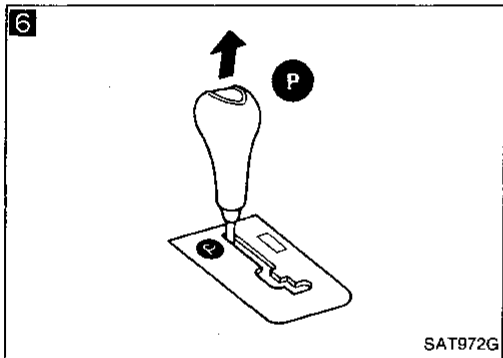
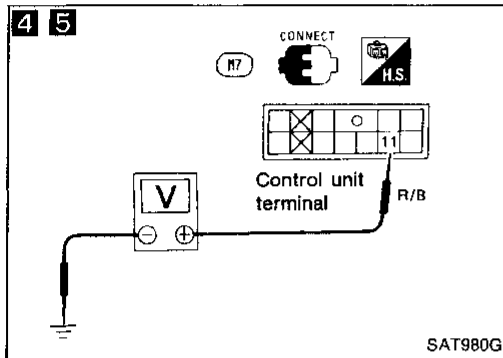

# TROUBLE DIAGNOSES — A/T Shift Lock System

## Diagnostic Procedure 2 (Cont'd)

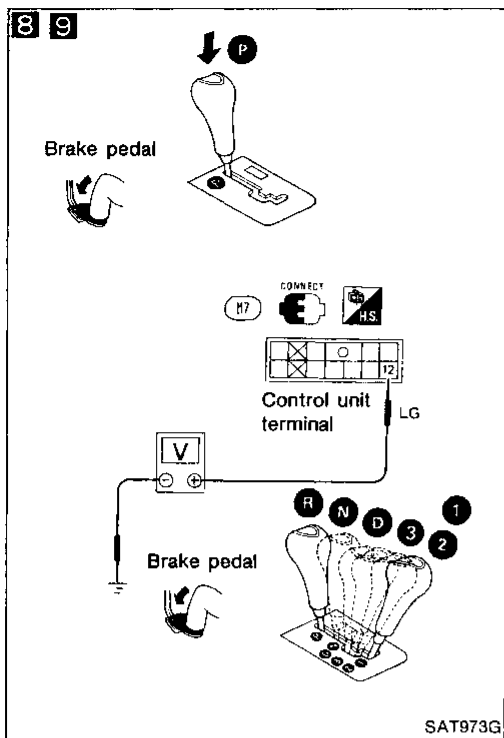

**8 9**

**CHECK INPUT SIGNAL (DETENTION SWITCH-KEY).**

1. Turn ignition switch to "ON" position. (Do not start engine.)
2. Check voltage between control unit harness terminal ⑫ and ground with brake pedal depressed and selector lever button pushed. **Battery voltage should exist.**
3. Check voltage between control unit harness terminal ⑫ and ground with selector lever set in any position except "P". **Battery voltage should exist.**

NG →

Check the following items:

1. Harness continuity between control unit harness terminal ⑫ and detention switch harness terminal ⑫
2. Harness continuity between detention switch harness terminal ⑪ and key switch harness terminal ⑪
3. Detention switch - key (Refer to "COMPONENT CHECK", AT-104.)

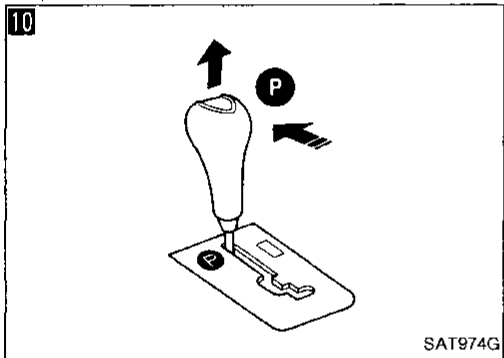

OK ↓

**10 11**

1. Set selector lever in "P" position and release selector lever button.
2. Turn ignition switch from "ON" to "OFF" position.

**CHECK OUTPUT SIGNAL (KEY LOCK SIGNAL).**

3. Turn ignition switch from "OFF" to "ON" position. (Do not start engine.)
4. Check voltage between key lock solenoid harness terminal ⑧ and ground at the moment ignition key is turned from OFF to ON. **Battery voltage should exist for approximately 0.1 seconds.**

NG →

Check harness continuity between shift lock solenoid harness terminal ⑧ and control unit harness terminal ⑧.

OK ↓

NG ↓

Repair harness or connector.

Replace control unit.

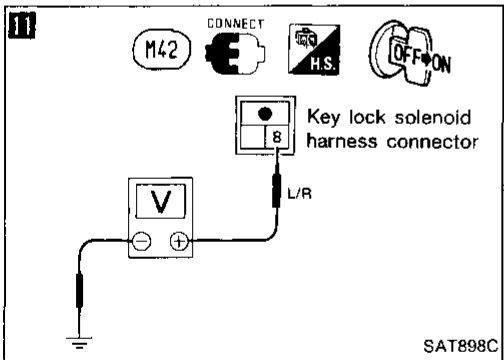

OK ↓

⑬

GI  
MA  
EM  
LC  
EF & EC  
FE  
AT  
PD  
FA  
RA  
BR  
ST  
RS  
BT  
HA  
EL  
IDX

# TROUBLE DIAGNOSES — A/T Shift Lock System

## Diagnostic Procedure 2 (Cont'd)

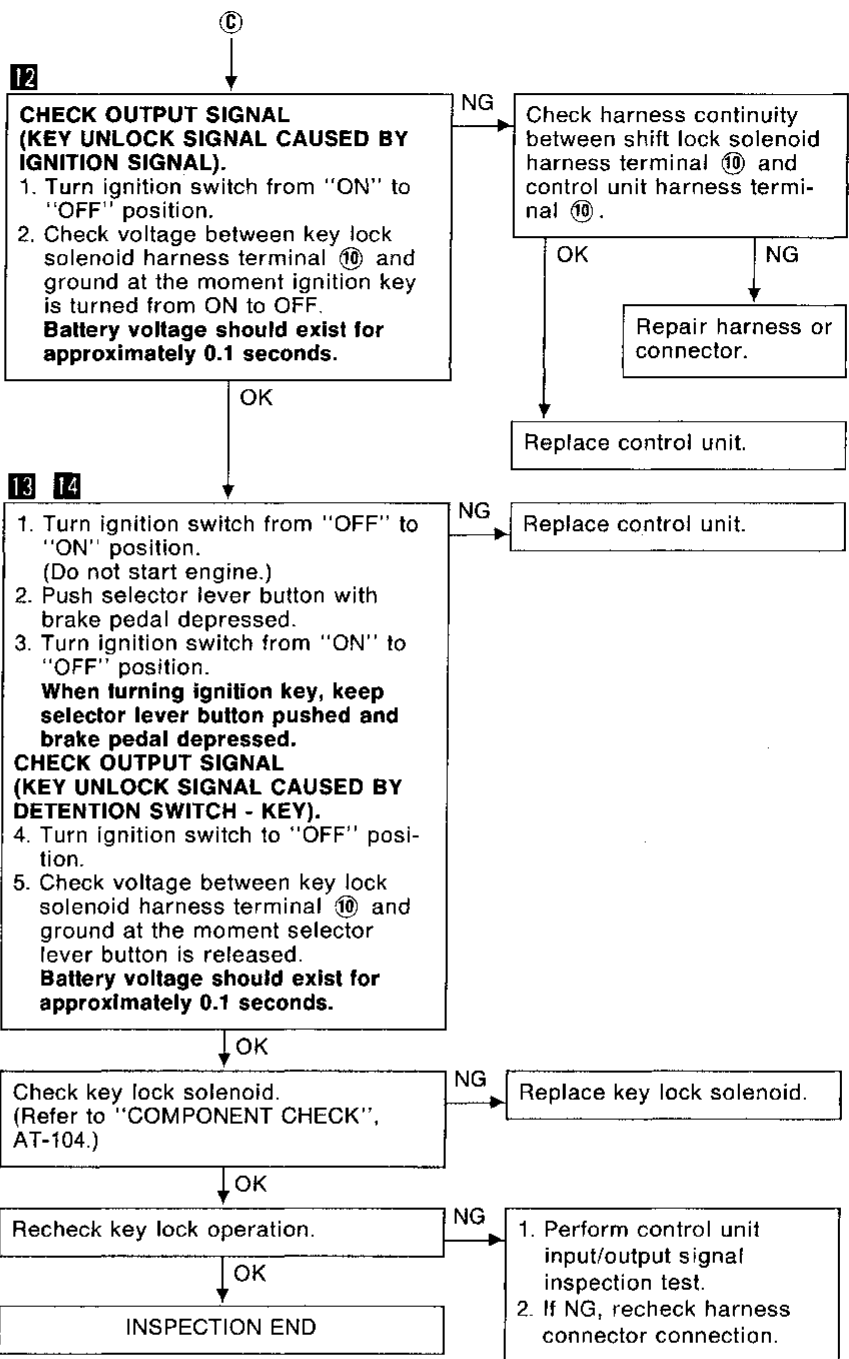
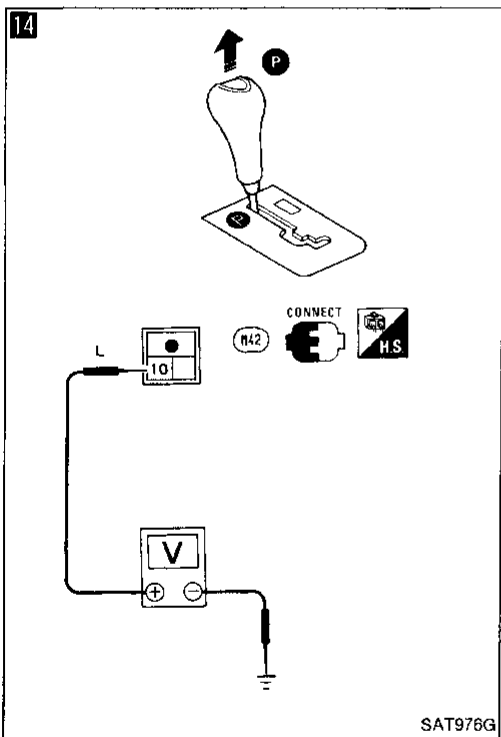
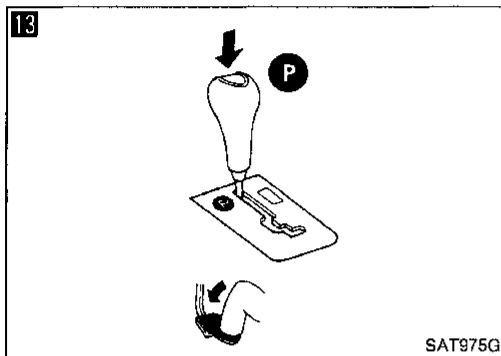
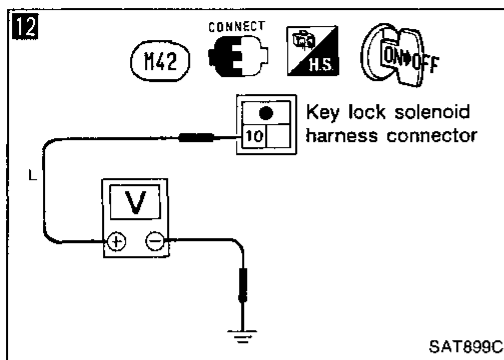

# TROUBLE DIAGNOSES — A/T Shift Lock System

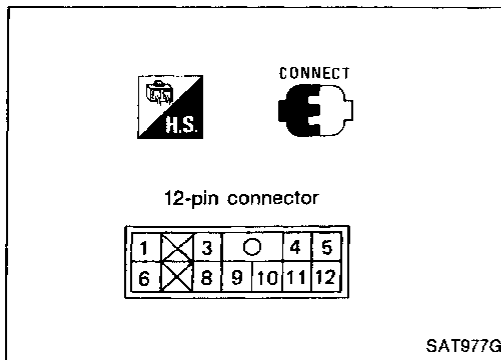



## Shift Lock Control Unit Inspection

- Measure voltage between each terminal by following "SHIFT LOCK CONTROL UNIT INSPECTION TABLE".
- Pin connector terminal layout.

## Shift Lock Control Unit Inspection Table

(Data are reference values.)

Terminal No.		Item	Condition	Judgment standard
⊕	⊖			
1		Shift lock signal	 When selector lever is set in "P" position and brake pedal is depressed	Battery voltage
			Except above	0V
3		Stop lamp switch	When brake pedal is depressed	Battery voltage
			When brake pedal is released	0V
4		Power source		Battery voltage
5	9	Detention switch (Shift)	<ul style="list-style-type: none"> <li>● When the key is in key cylinder, selector lever is in "P" position, and selector lever button pushed.</li> <li>● When the key is in key cylinder, selector lever is set in any position except "P", and selector lever button released.</li> </ul>	Battery voltage
			Except above	0V
6		Ignition signal		Battery voltage
8	10	Key lock signal	When ignition switch is turned from LOCK, OFF or ACC to ON.	Battery voltage (Approximately 0.1 seconds)
			Except above	0V
9	—	Ground	—	—
10	8	Key unlock signal	Selector lever in "P" position with button released, and ignition key turned to LOCK, OFF or ACC.	Battery voltage (Approximately 0.1 seconds)
			Except above	0V
11	9	Key switch	When key is inserted into key cylinder	Battery voltage
			When key is removed from key cylinder	0V
12	9	Detention switch (Key)	<ul style="list-style-type: none"> <li>● When the key is in key cylinder, selector lever is in "P" position, and selector lever button pushed.</li> <li>● When the key is in key cylinder, selector lever is set in any position except "P", and selector lever button released.</li> </ul>	Battery voltage
			Except above	0V

GI  
 MA  
 EM  
 LC  
 EF & EC  
 FE  
 AT  
 PD  
 FA  
 RA  
 BR  
 ST  
 RS  
 BT  
 HA  
 EL  
 IDX

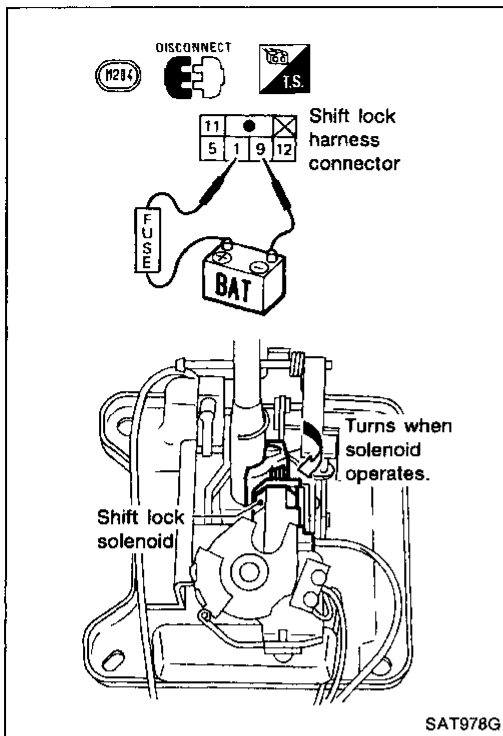

## Component Check

### SHIFT LOCK SOLENOID

- Check operation by applying battery voltage to shift lock harness connector.

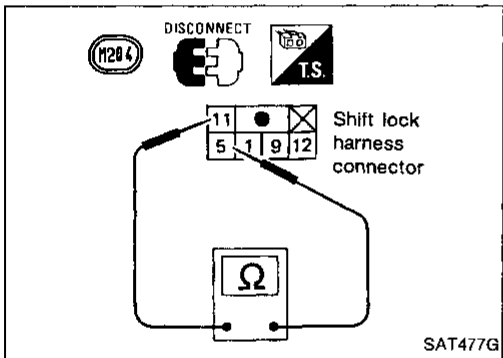

### DETENTION SWITCH

#### Shift

- Check continuity between terminals ⑤ and ⑪ of shift lock harness connector.

Condition	Continuity
<ul style="list-style-type: none"> <li>• When selector lever is set in "P" position, and selector lever button pushed.</li> <li>• When selector lever is set in any position except "P", and selector lever button released.</li> </ul>	Yes
Except the above	No

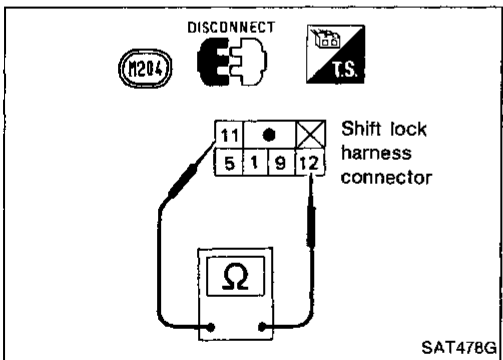

#### Key

- Check continuity between terminals ⑪ and ⑫ of shift lock harness connector.

Condition	Continuity
<ul style="list-style-type: none"> <li>• When selector lever is set in "P" position, and selector lever button pushed.</li> <li>• When selector lever is set in any position except "P", and selector lever button released.</li> </ul>	Yes
Except the above	No

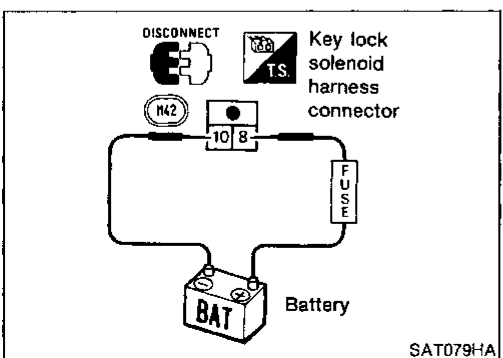

### KEY LOCK SOLENOID

- Check operation by applying battery voltage to key lock solenoid harness connector.

**Operating sound must be emitted.**



# TROUBLE DIAGNOSES — A/T Shift Lock System

## Component Check (Cont'd)

### KEY SWITCH

- Check continuity between terminals ④ and ⑪ of key switch harness connector.

Condition	Continuity
When key is inserted into key cylinder	Yes
When key is removed from key cylinder	No

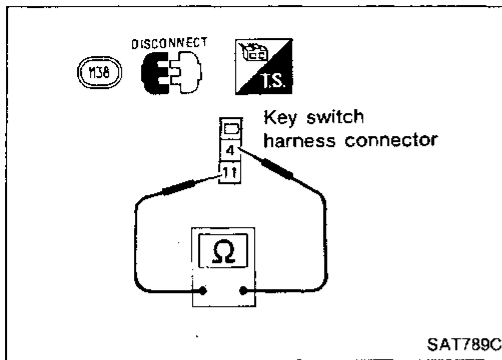

### STOP LAMP SWITCH

- Check continuity between terminals ② and ③ of stop lamp switch harness connector.

Condition	Continuity
When brake pedal is depressed	Yes
When brake pedal is released	No

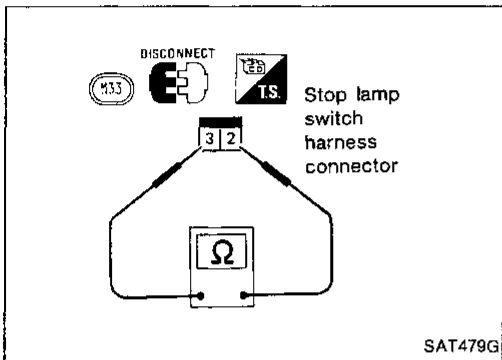

**Check stop lamp switch after adjusting brake pedal — Refer to BR section (BRAKE PEDAL AND BRACKET, Adjustment).**

GI

MA

EM

LC

EF &  
EC

FE

AT

PD

FA

RA

BR

ST

RS

BT

HA

EL

DX

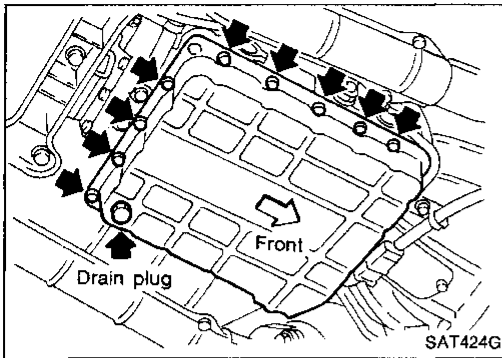

## Control Valve Assembly and Accumulators Inspection

1. Drain ATF.
2. Remove oil pan and gasket.
3. Remove oil strainer.
4. Remove control valve assembly by removing fixing bolts and disconnecting harness connector.

### Bolt length and location

Bolt symbol	ℓ mm (in)	ℓ
Ⓐ	33 (1.30)	
Ⓑ	45 (1.77)	

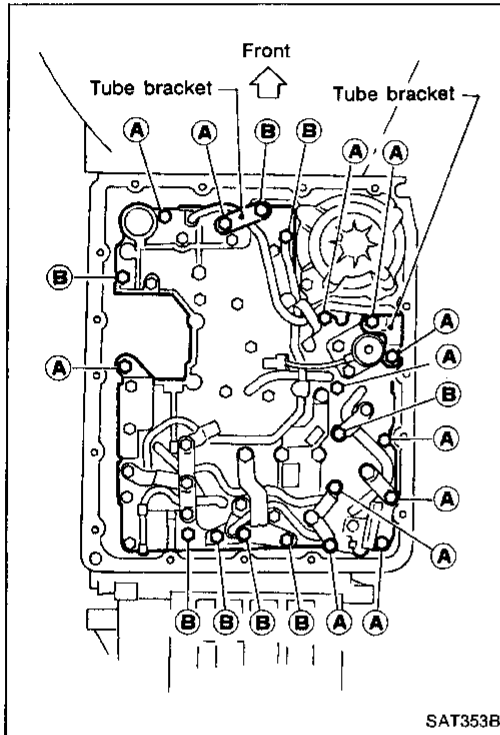

5. Remove solenoids and valves from valve body if necessary.
6. Remove terminal cord assembly if necessary.

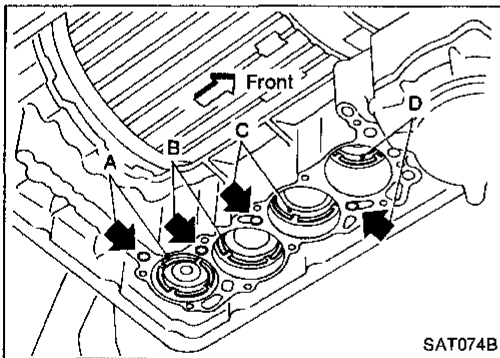

7. Remove accumulators A, B, C and D by applying compressed air if necessary.

- Hold each piston with rag.

#### Note:

- A: N-D Accumulator**
- B: 2-3 Accumulator**
- C: 1-2 Accumulator**
- D: 3-4 (N-R) Accumulator**

8. Reinstall any part removed.
- Always use new sealing parts.

### Kickdown Switch Adjustment

1. Adjust accelerator cable — Refer to FE section (ACCELERATOR CONTROL SYSTEM).
2. Adjust clearance "C" between stopper rubber and end of kickdown switch thread while depressing accelerator pedal fully.

**Clearance "C": 0.3 - 1.0 mm (0.012 - 0.039 in)**

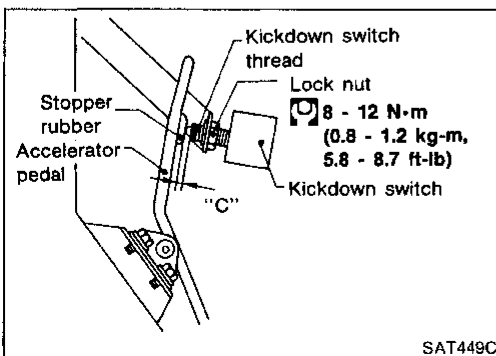

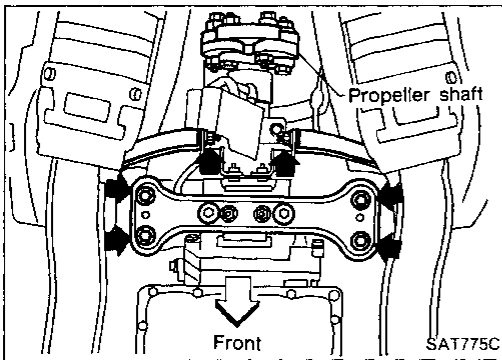

### Revolution Sensor Replacement

1. Remove exhaust tube.
  2. Remove propeller shaft from vehicle. — Refer to PD section (PROPELLER SHAFT, Removal).
  3. Remove rear mounting member from body while supporting A/T with a jack.
  4. Remove revolution sensor from A/T assembly.
  5. Reinstall any part removed.
- **Always use new sealing parts.**

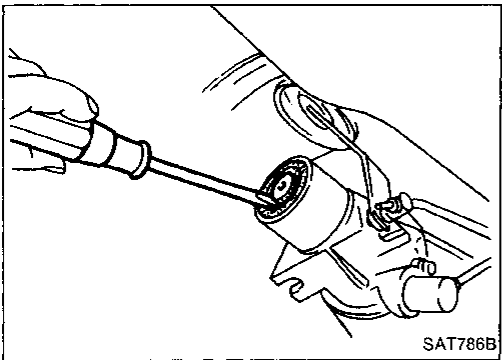
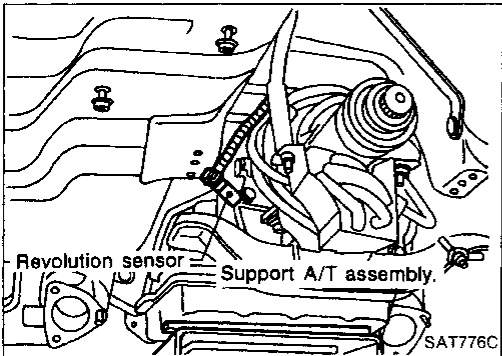

### Rear Oil Seal Replacement

1. Remove exhaust tube.
  2. Remove propeller shaft from vehicle. — Refer to PD section (PROPELLER SHAFT, Removal).
  3. Remove rear oil seal.
  4. Install rear oil seal.
  5. Reinstall any part removed.
- **Apply ATF before installing.**

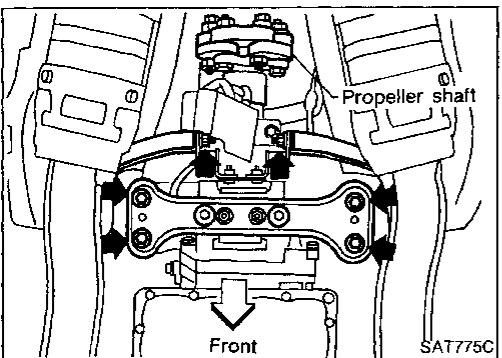
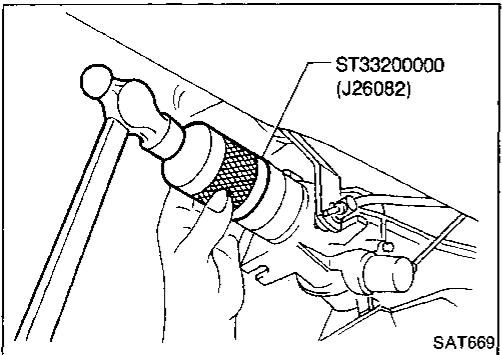

### Parking Components Inspection

1. Remove exhaust tube.
2. Remove propeller shaft from vehicle. — Refer to PD section (PROPELLER SHAFT, Removal).
3. Remove rear engine mounting member from A/T assembly while supporting A/T with a jack.

GI

MA

EM

LC

EF &  
EC

FE

AT

PD

FA

RA

BR

ST

RS

BT

HA

EL

IDX

## ON-VEHICLE SERVICE

### Parking Components Inspection (Cont'd)

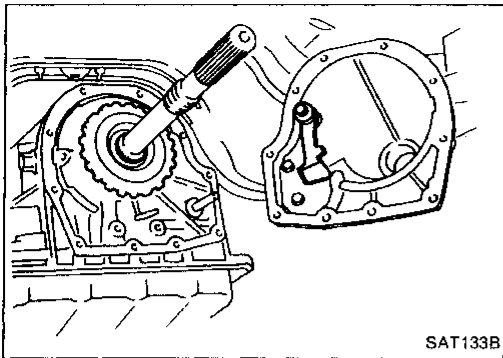

4. Remove rear extension from transmission case.
  5. Replace parking components if necessary.
  6. Reinstall any part removed.
- **Always use new sealing parts.**

### Inhibitor Switch Adjustment

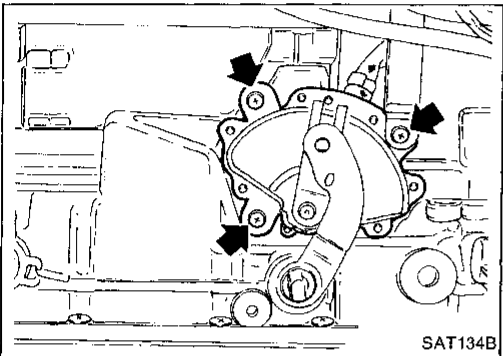

1. Remove manual control linkage from manual shaft of A/T assembly.
2. Set manual shaft of A/T assembly in "N" position.
3. Loosen inhibitor switch fixing bolts.

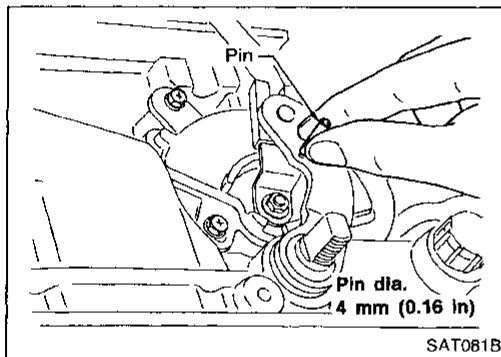

4. Insert pin into adjustment holes in both inhibitor switch and manual shaft of A/T assembly as near vertical as possible.
5. Reinstall any part removed.
6. Check continuity of inhibitor switch. — Refer to "Electrical Components Inspection", AT-75.

### Manual Control Linkage Adjustment

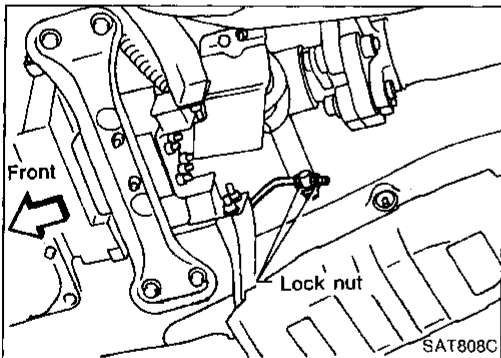

Move selector lever from "P" position to "1" position. You should be able to feel the detents in each position. If the detents cannot be felt or the position pointer is improperly aligned, adjust the linkage.

1. Place selector lever in "P" position.
2. Loosen lock nuts.

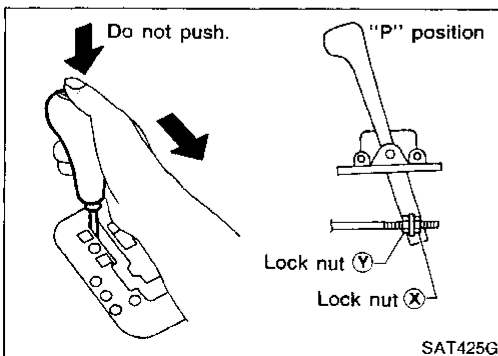

3. Tighten lock nut X until it touches trunnion pulling selector lever toward "R" position side without pushing button.
4. Back off lock nut X 1 turn and tighten lock nut Y to the specified torque.  
**Lock nut:**  
Ⓜ: 11 - 15 N·m (1.1 - 1.5 kg·m, 8 - 11 ft·lb)
5. Move selector lever from "P" position to "1" position. Make sure that selector lever can move smoothly.

# REMOVAL AND INSTALLATION

## Removal

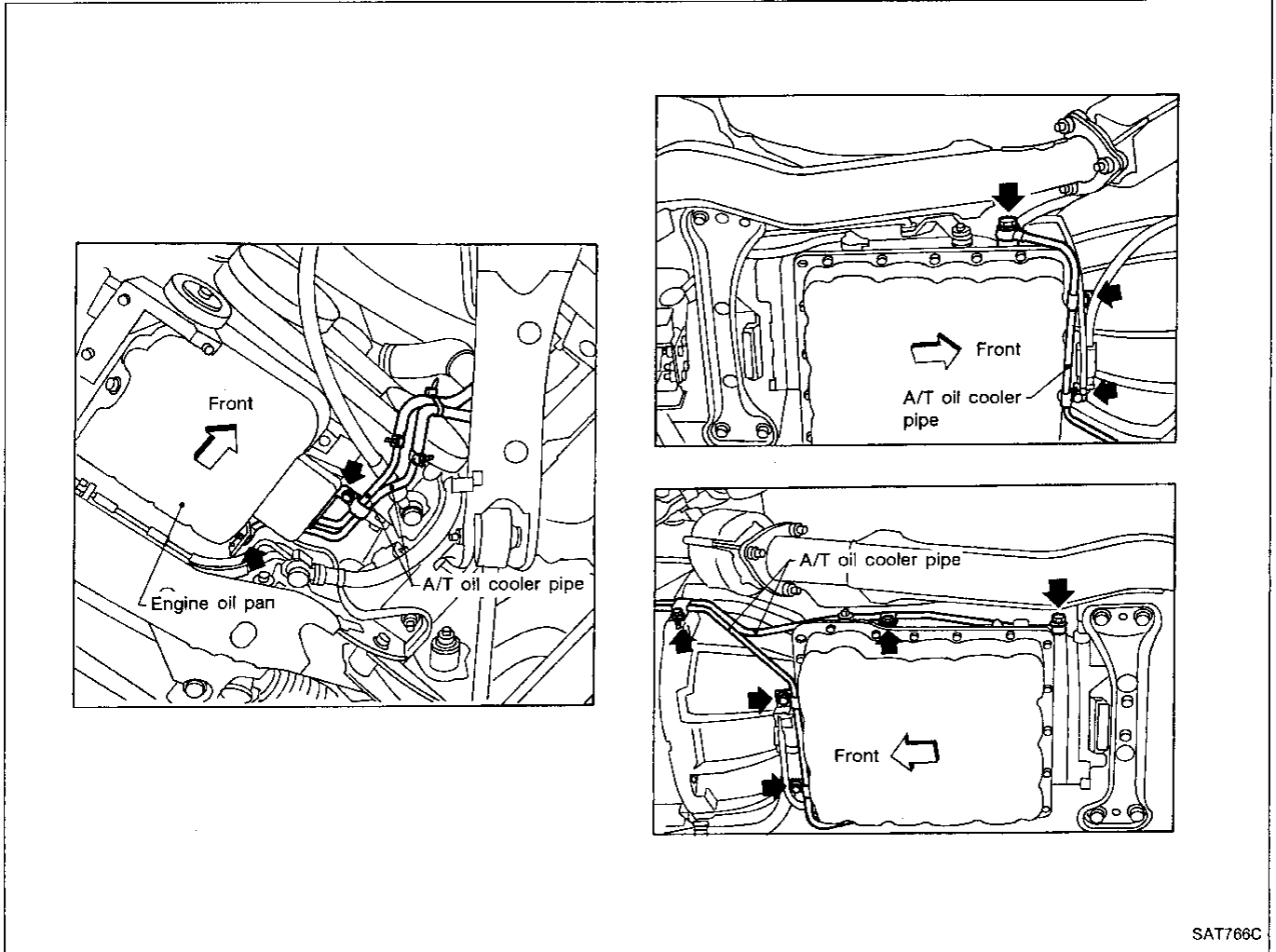

- Remove fluid charging pipe from A/T assembly.
- Remove oil cooler pipe clamps.
- Remove oil cooler pipe from A/T assembly.

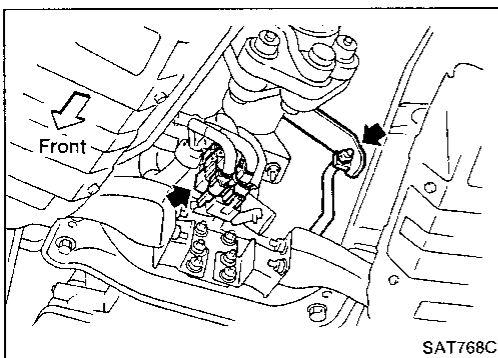

- Disconnect A/T harness connectors and speed sensor harness connector.
- Remove control linkage from selector lever.
- Plug up openings such as the oil charging pipe hole, etc.

## REMOVAL AND INSTALLATION

### Removal (Cont'd)

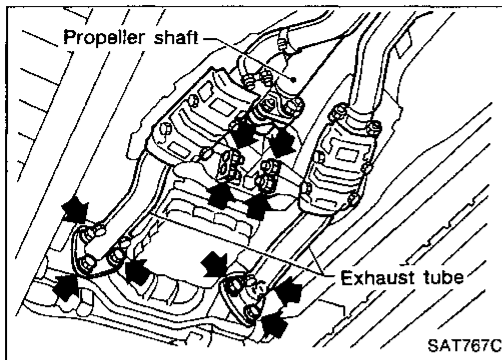

- Remove exhaust tube.
- Remove propeller shaft — Refer to PD section (PROPELLER SHAFT, Removal).
- **Insert plug into rear oil seal after removing propeller shaft.**
- **Be careful not to damage spline, sleeve yoke and rear oil seal, when removing propeller shaft.**

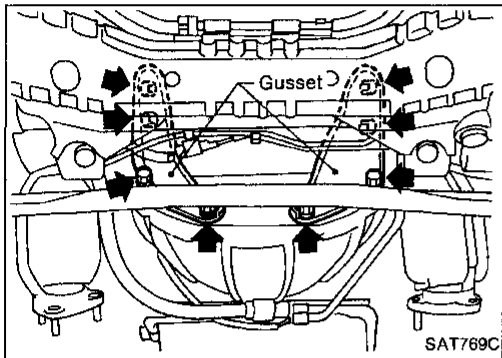

- Remove gusset securing engine to A/T assembly.

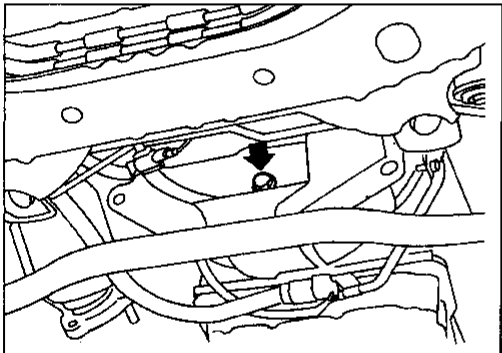

- Remove bolts securing torque converter to drive plate.
- **Remove the bolts by turning crankshaft.**

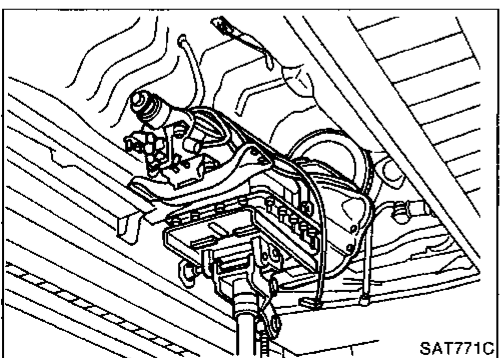
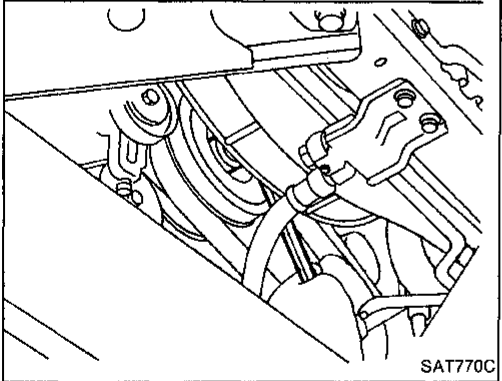

- Support A/T assembly by placing a jack under oil pan.
- Remove rear mounting bracket from body.
- Remove bolts securing A/T assembly to engine.
- Lower A/T assembly.

# REMOVAL AND INSTALLATION

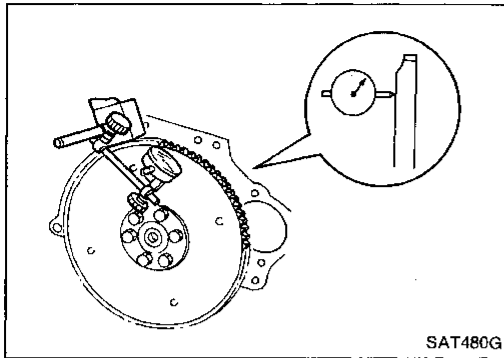

## Installation

- Drive plate runout  
**Maximum allowable runout:**  
Refer to EM section ("Inspection", "CYLINDER BLOCK").  
If this runout is out of specification, replace drive plate with ring gear.

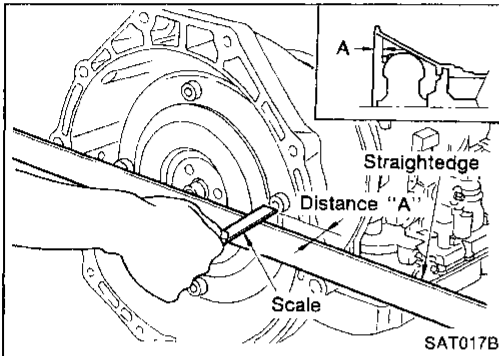

- When connecting torque converter to transmission, measure distance "A" to be certain that they are correctly assembled.

**Distance "A":**  
**22.0 mm (0.866 in) or more**

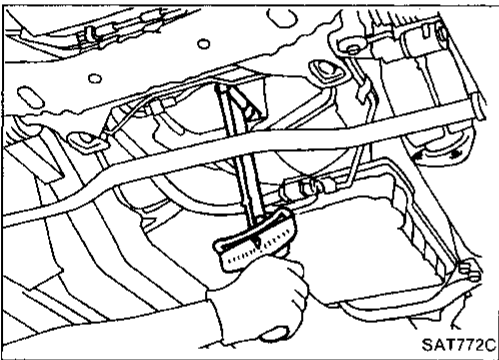

- Install bolts securing converter to drive plate.
- **After installing converter to drive plate, rotate crankshaft several turns. Make sure that transmission rotates freely without binding.**

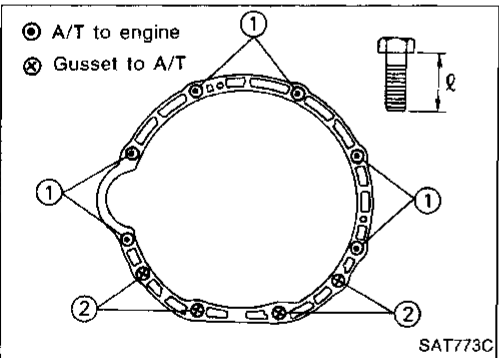

- Tighten bolts securing transmission to engine.

Bolt No.	Tightening torque N·m (kg·m, ft·lb)	Bolt length "l" mm (in)
①	108 - 118 (11.0 - 12.0, 80 - 87)	70 (2.76)
②	69 - 78 (7.0 - 8.0, 51 - 58)	30 (1.18)
Gusset to engine	69 - 78 (7.0 - 8.0, 51 - 58)	30 (1.18)

- Reinstall any part removed.
- Check fluid level in transmission.
- Move selector lever through all positions to be sure that transmission operates correctly.  
With parking brake applied, rotate engine at idling. Move selector lever through "N" to "D", to "3" to "2", to "1" and to "R". A slight shock should be felt by hand gripping selector each time transmission is shifted.
- Perform road test. — Refer to "ROAD TESTING", AT-21.

# MAJOR OVERHAUL

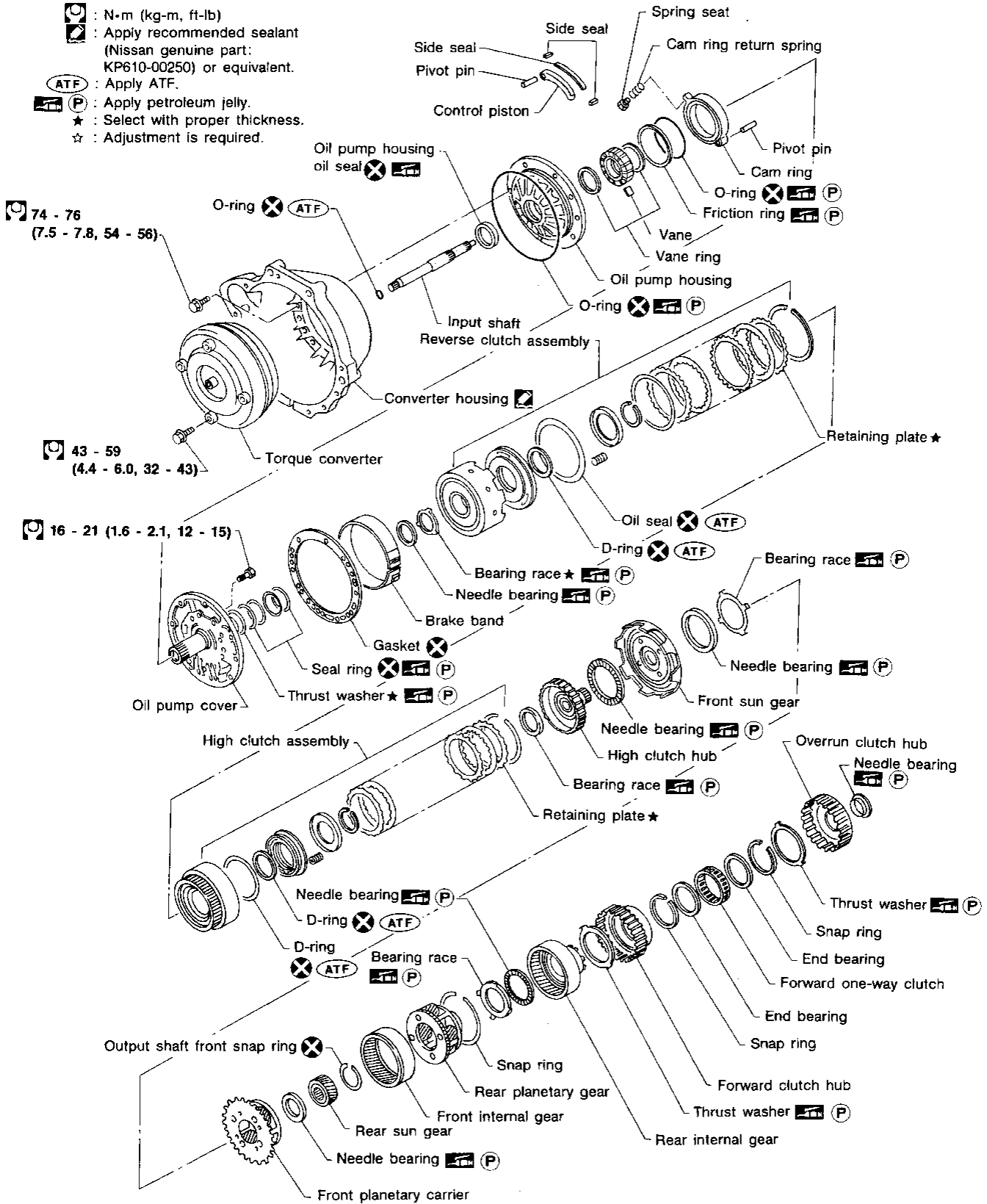



# MAJOR OVERHAUL

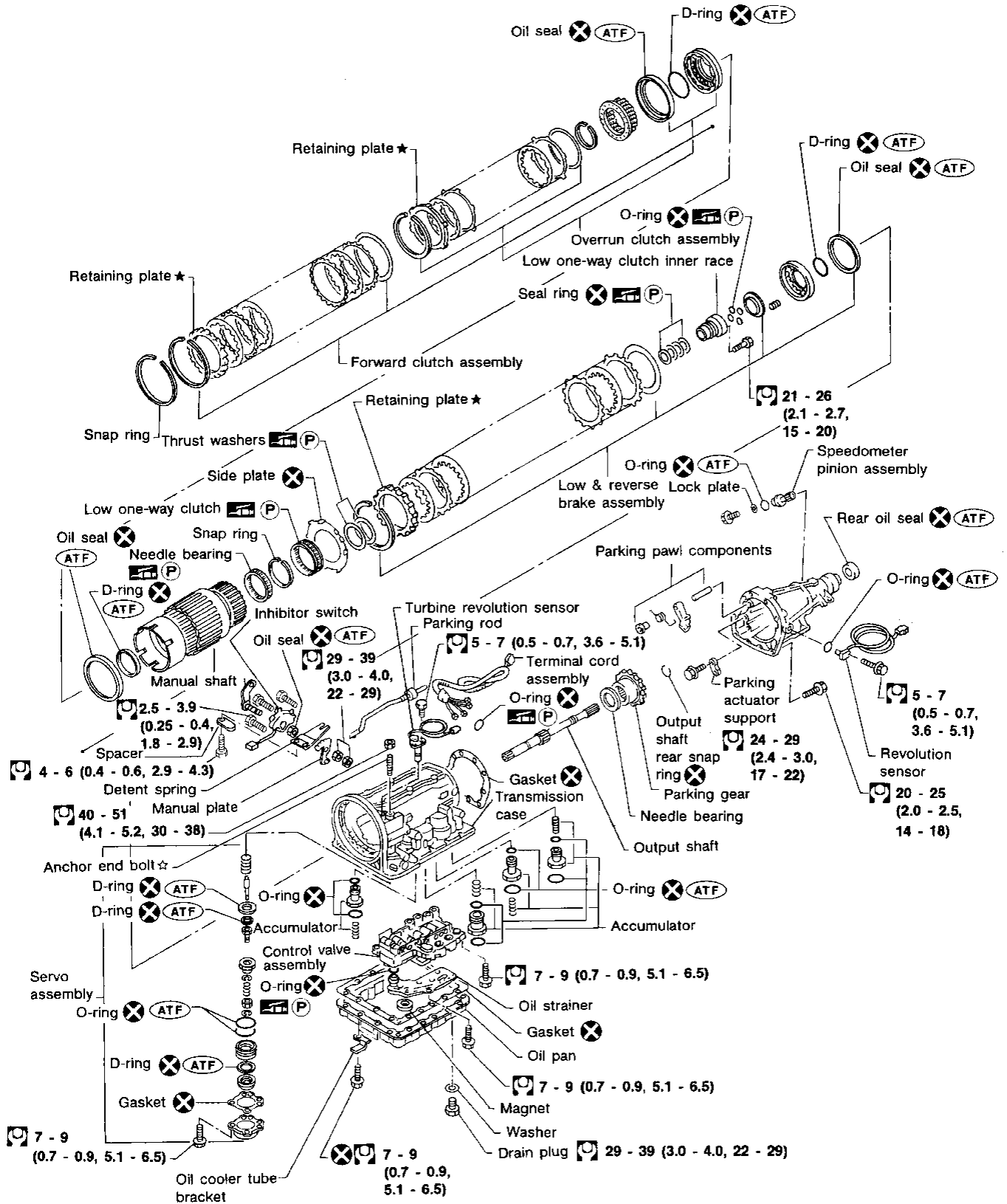

GI  
MA  
EM  
LC  
EF & EC  
FE  
**AT**  
PD  
FA  
RA  
BR  
ST  
RS  
BT  
HA  
EL  
IDX

# MAJOR OVERHAUL

## Oil Channel

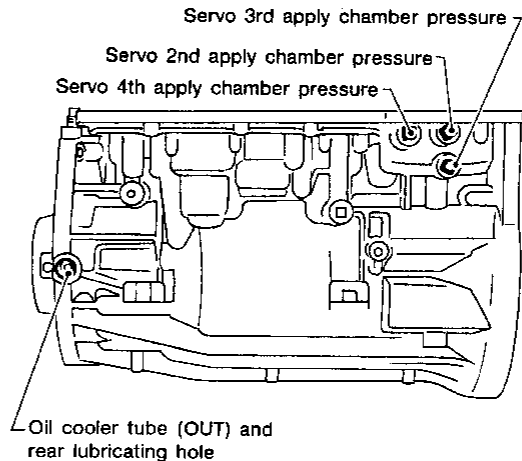
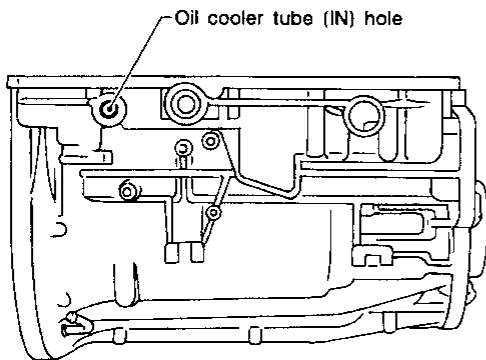
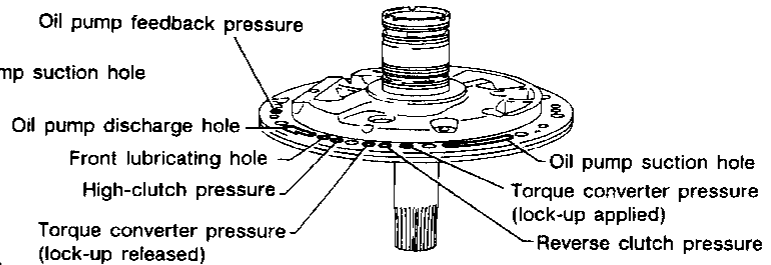
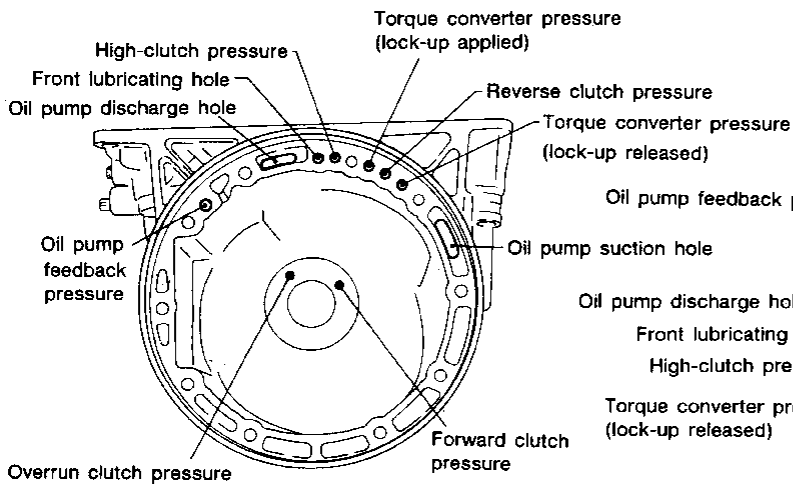
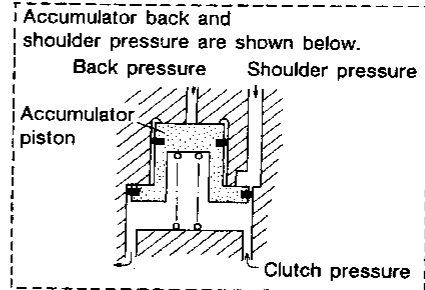
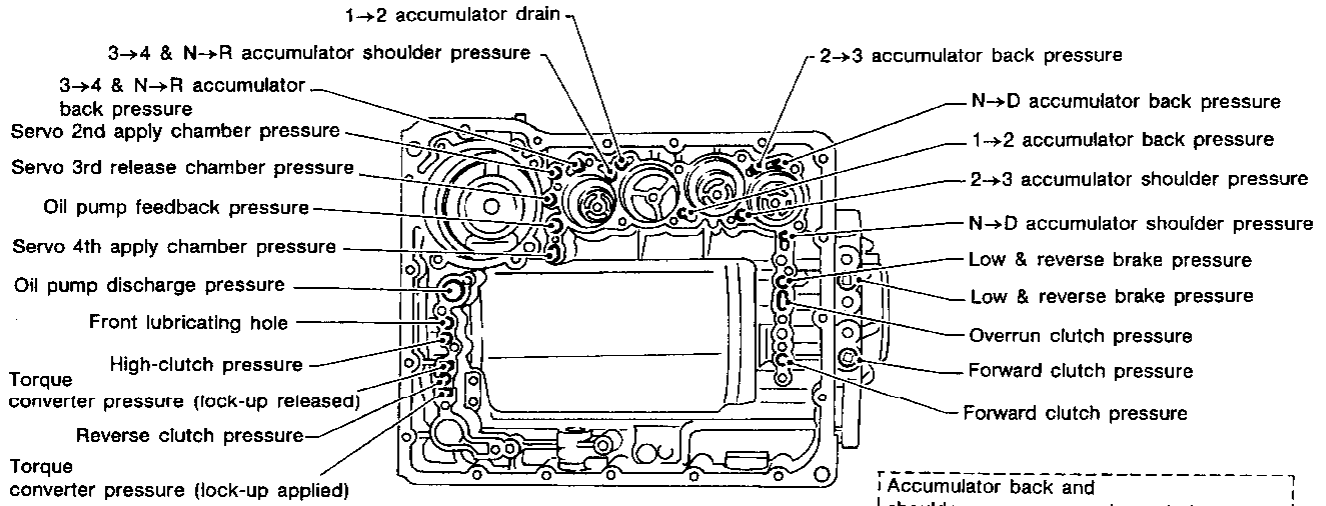

## Locations of Needle Bearings, Thrust Washers and Snap Rings

Outer diameter of snap rings

Item number	Outer diameter mm (in)
②, ⑤	164.0 (6.46)
③	176.0 (6.93)
⑥	172.0 (6.77)

Thrust washers

Item number	Color
①	Black
④	White
⑬	—

Outer diameter of bearing races

Item number	Outer diameter mm (in)
⑦	43.5 (1.713)
⑩	82.0 (3.228)
⑬	63.2 (2.488)

Installation of one-piece bearings

Item number	Bearing race (black) location
⑯	Rear side

Inner and outer diameter of needle bearings

Item number	Outer diameter mm (in)	Inner diameter mm (in)	Number of needles
⑦	47.0 (1.850)	30.0 (1.181)	—
⑧	53.0 (2.087)	35.1 (1.382)	—
⑨, ⑩	85.0 (3.346)	62.7 (2.468)	—
⑪, ⑫	64.0 (2.520)	45.0 (1.772)	52
⑬	64.0 (2.520)	45.0 (1.772)	50
⑭	59.5 (2.343)	38.0 (1.496)	—
⑯	64.0 (2.520)	—	—

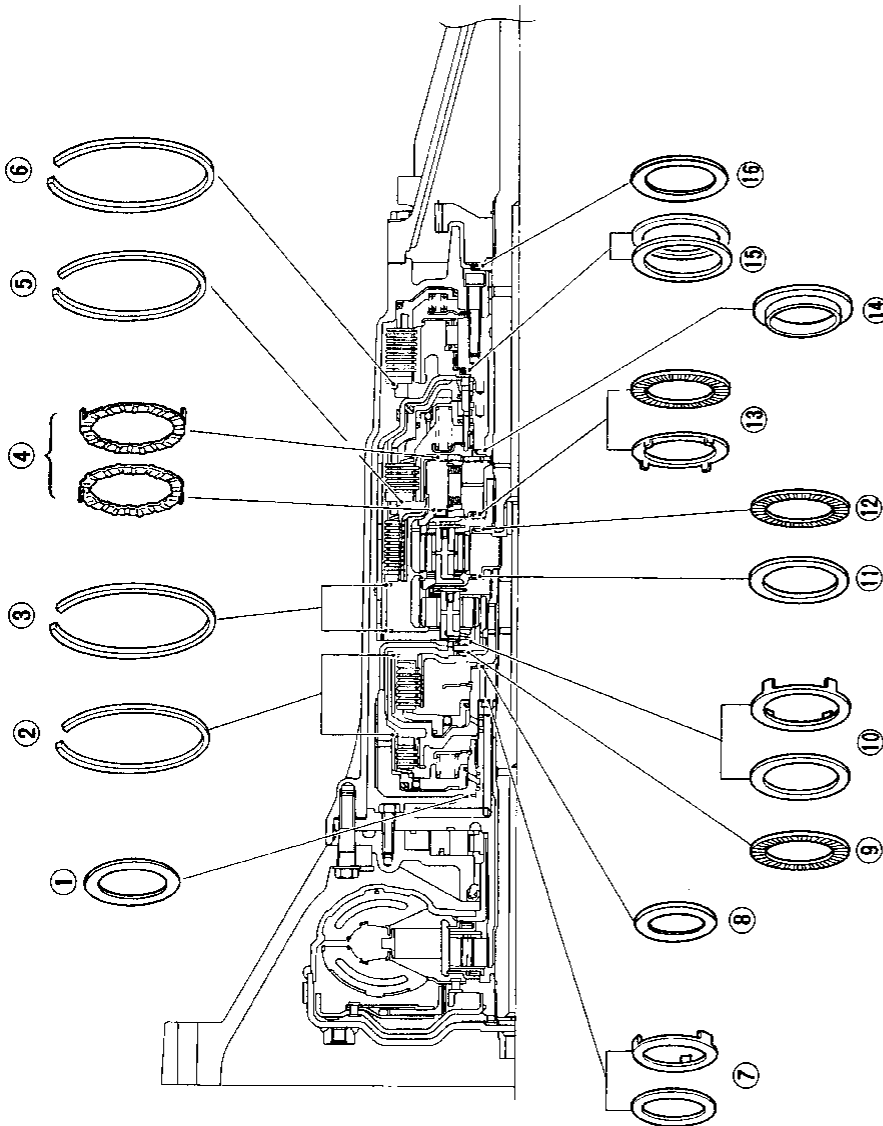

GI  
 MA  
 EM  
 LC  
 EF &  
 EC  
 FE  
**AT**  
 PD  
 FA  
 RA  
 BR  
 ST  
 RS  
 BT  
 HA  
 EL  
 IDX

## DISASSEMBLY

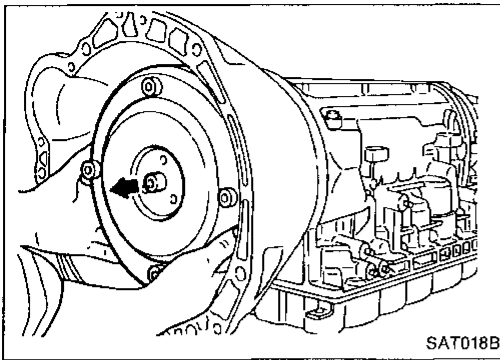

1. Remove torque converter by holding it firmly and turning while pulling straight out.

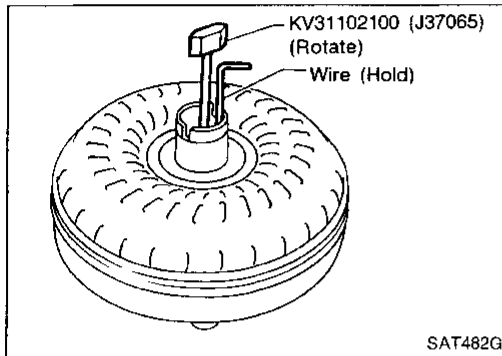

2. Check torque converter one-way clutch.
  - a. Insert Tool into spline of one-way clutch inner race.
  - b. Hook bearing support unitized with one-way clutch outer race with suitable wire.
  - c. Check that one-way clutch inner race rotates only clockwise with Tool while holding bearing support with wire.

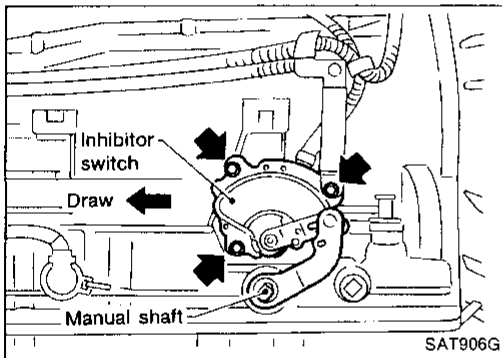

3. Remove inhibitor switch from transmission case.

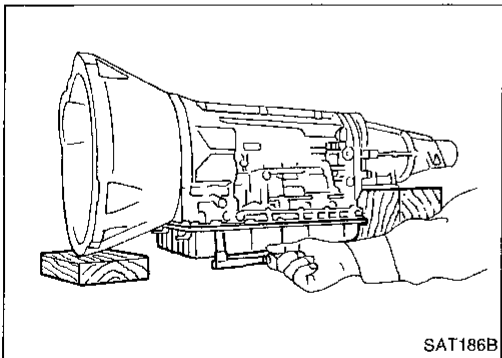

4. Remove oil pan.
  - a. Drain ATF from drain plug.
  - b. Raise oil pan by placing wooden blocks under converter housing and rear extension.
  - c. Separate the oil pan and transmission case.
  - **Always place oil pan straight down so that foreign particles inside will not move.**

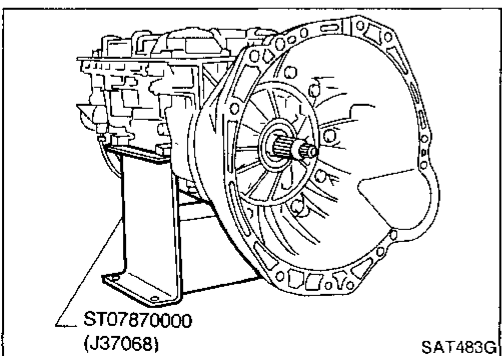

5. Place transmission into Tool with the control valve facing up.

# DISASSEMBLY

6. Check oil pan and oil strainer for accumulation of foreign particles.
  - If materials of clutch facing are found, clutch plates may be worn.
  - If metal filings are found, clutch plates, brake bands, etc. may be worn.
  - If aluminum filings are found, bushings or aluminum cast parts may be worn.

In above cases, replace torque converter and check unit for cause of particle accumulation.

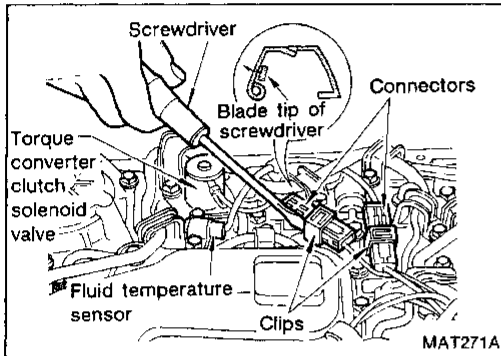

7. Remove torque converter clutch solenoid valve and fluid temperature sensor connectors.

- **Be careful not to damage connector.**

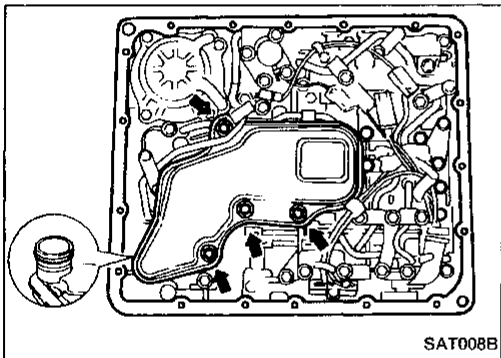

8. Remove oil strainer.
  - a. Remove oil strainer from control valve assembly. Then remove O-ring from oil strainer.

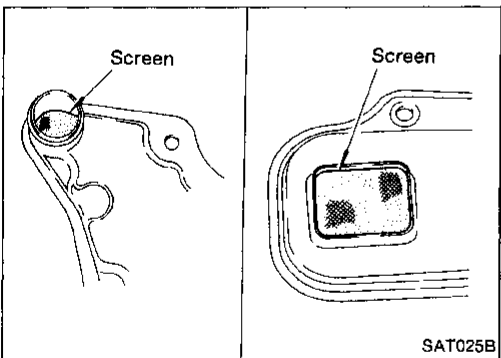

- b. Check oil strainer screen for damage.

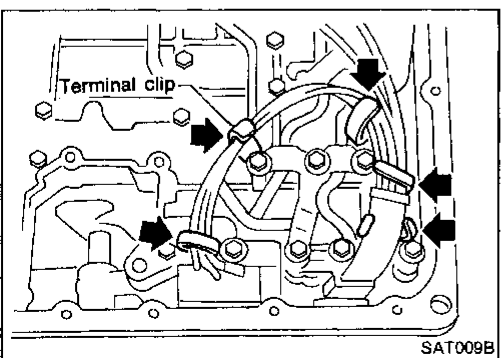

9. Remove control valve assembly.
  - a. Straighten terminal clips to free terminal cords then remove terminal clips.

GI  
MA  
EM  
LC  
EF & EC  
FE  
AT  
PD  
FA  
RA  
BR  
ST  
RS  
BT  
HA  
EL  
IDX

## DISASSEMBLY

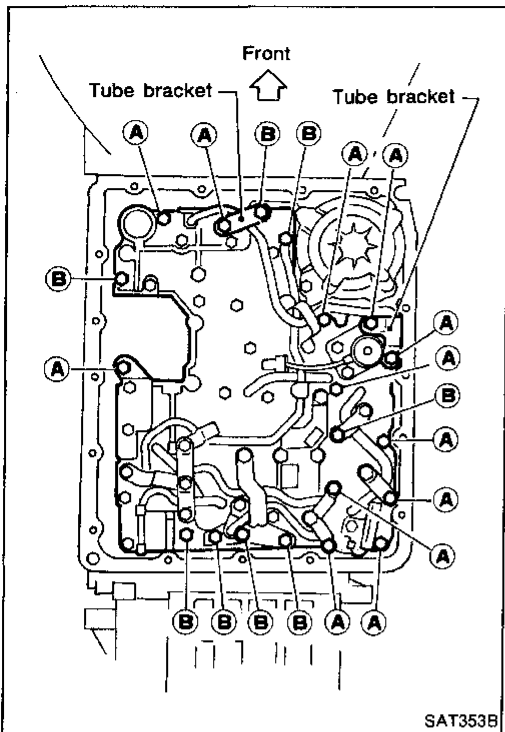

- b. Remove bolts **(A)** and **(B)**, and remove control valve assembly from transmission.

Bolt	ℓ mm (in)	
<b>(A)</b>	33 (1.30)	
<b>(B)</b>	45 (1.77)	

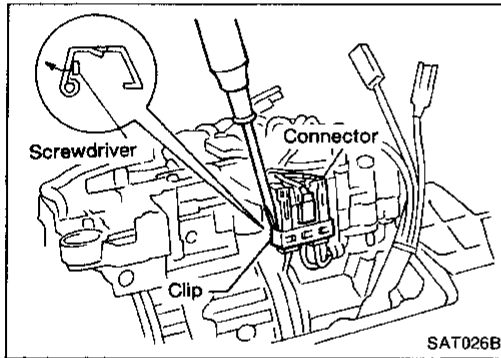

- c. Remove solenoid connector.
- **Be careful not to damage connector.**

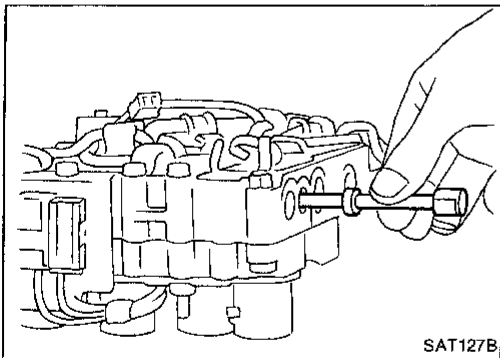

- d. Remove manual valve from control valve assembly.

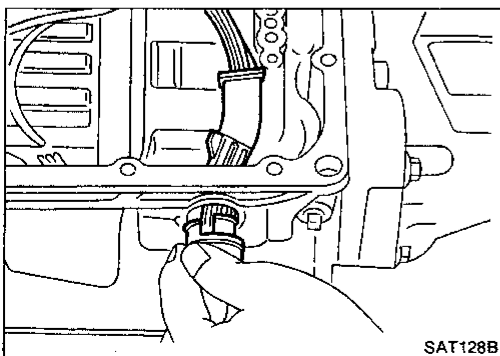

10. Remove terminal cord assembly from transmission case while pushing on stopper.
- **Be careful not to damage cord.**
  - **Do not remove terminal cord assembly unless it is damaged.**

# DISASSEMBLY

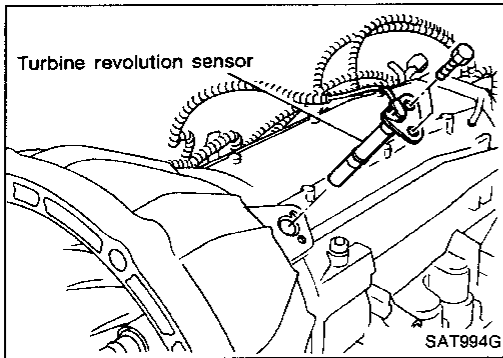

11. Remove turbine revolution sensor.

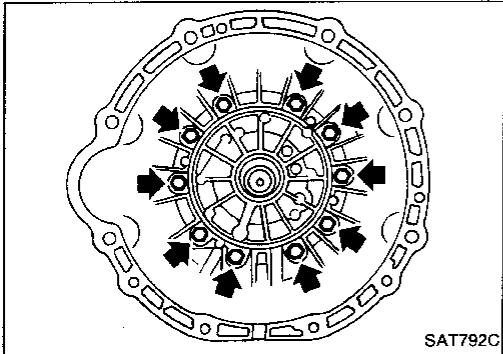

12. Remove converter housing.
- Remove converter housing from transmission case.
  - Remove traces of sealant
- **Be careful not to scratch converter housing.**

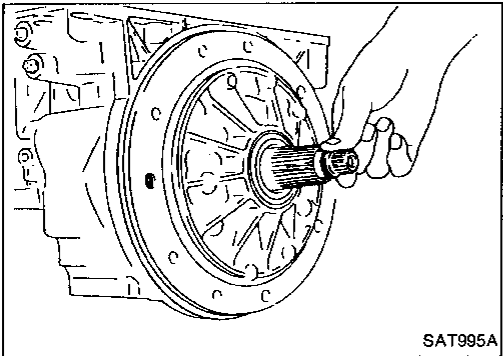

13. Remove O-ring from input shaft.

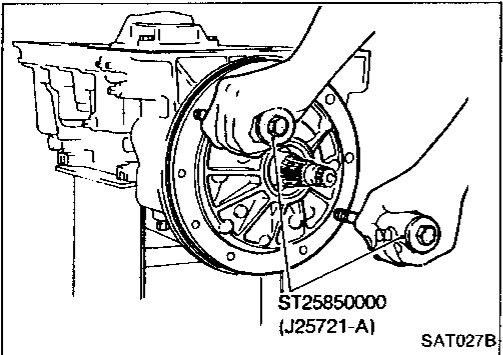

14. Remove oil pump assembly.
- Attach Tool to oil pump assembly and extract it evenly from transmission case.

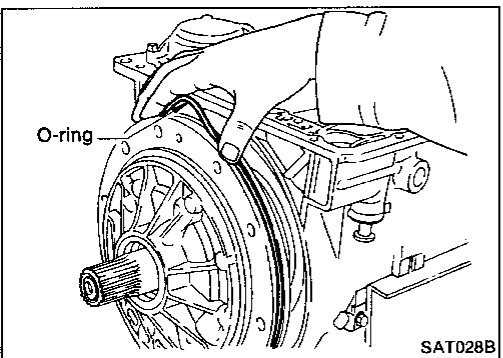

- Remove O-ring from oil pump assembly.
  - Remove traces of sealant from oil pump housing.
- **Be careful not to scratch pump housing.**

GI

MA

EM

LC

EF &  
EC

FE

AT

PD

FA

RA

BR

ST

RS

BT

HA

EL

IDX

## DISASSEMBLY

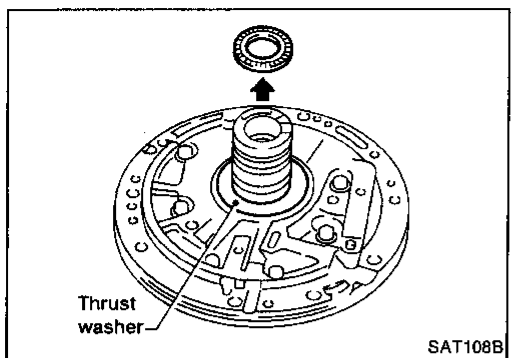

- d. Remove needle bearing and thrust washer from oil pump assembly.

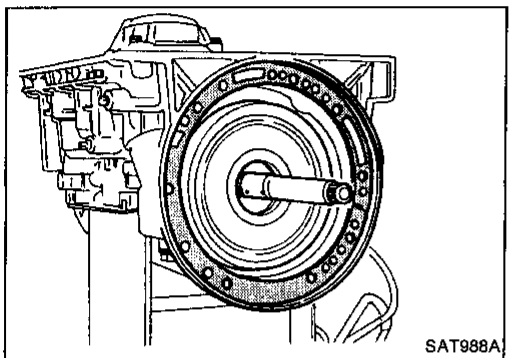

15. Remove input shaft and oil pump gasket.

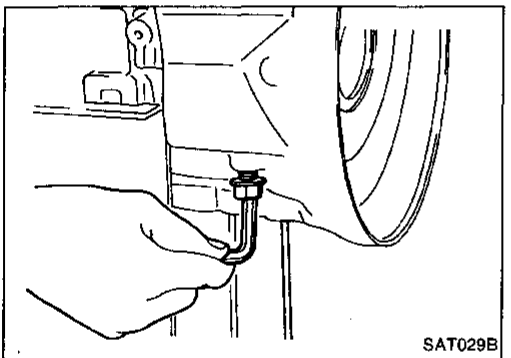

16. Remove brake band and band strut.  
a. Loosen lock nut and remove band servo anchor end pin from transmission case.

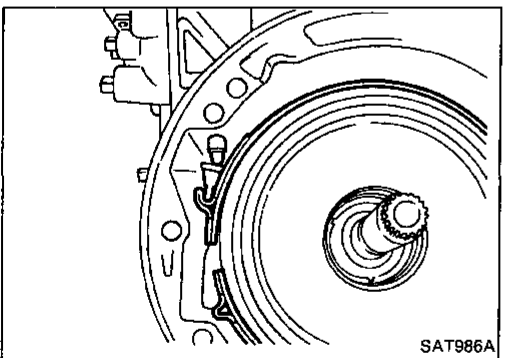

- b. Remove brake band and band strut from transmission case.

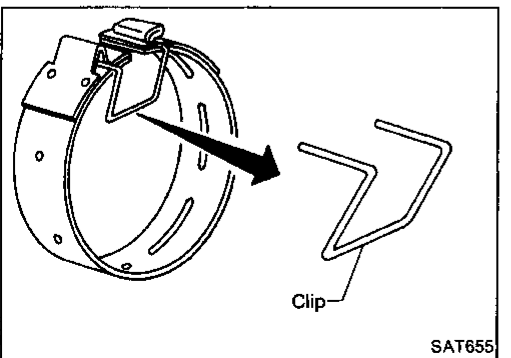

- c. Hold brake band in a circular shape with clip. Check brake band facing for damage, cracks, wear or burns.



# DISASSEMBLY

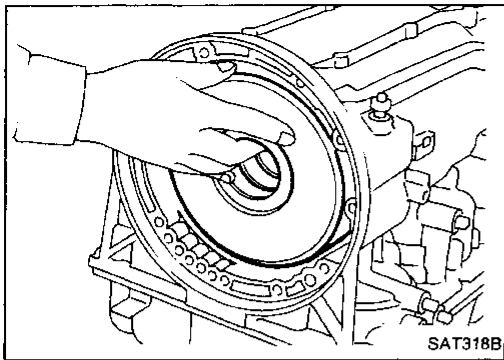

17. Remove front side clutch and gear components.  
a. Remove reverse clutch assembly from transmission case.

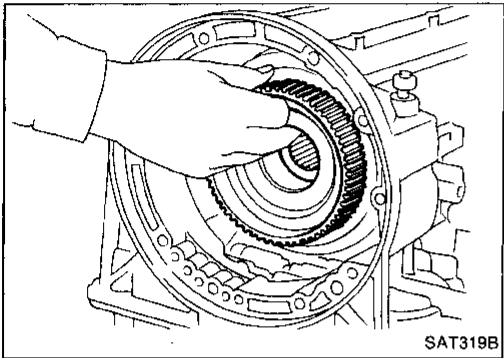

- b. Remove high clutch assembly from transmission case.

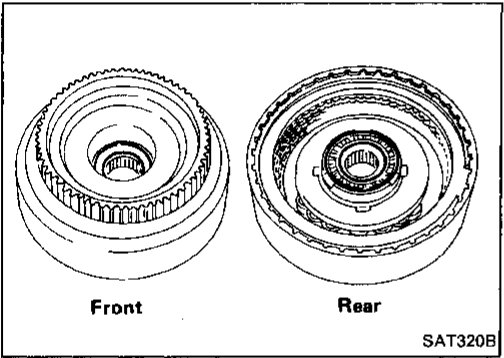

- c. Remove front bearing race from high clutch assembly.  
d. Remove rear needle bearing from high clutch assembly.

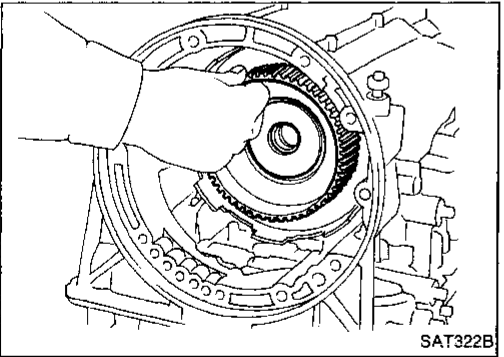

- e. Remove high clutch hub from transmission case.

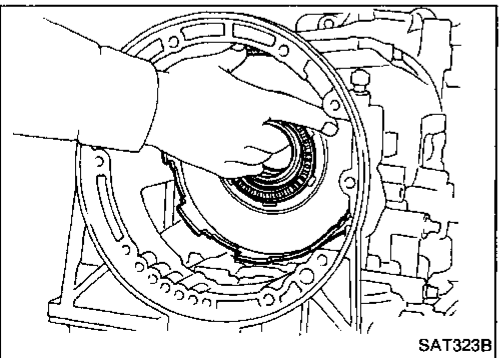

- f. Remove front sun gear from transmission case.

GI

MA

EM

LC

EF &  
EC

FE

AT

PD

FA

RA

BR

ST

RS

BT

HA

EL

IDX

## DISASSEMBLY

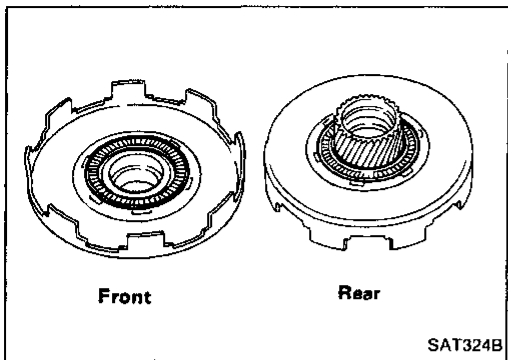

- g. Remove front needle bearing from front sun gear.
- h. Remove rear needle bearing from front sun gear.

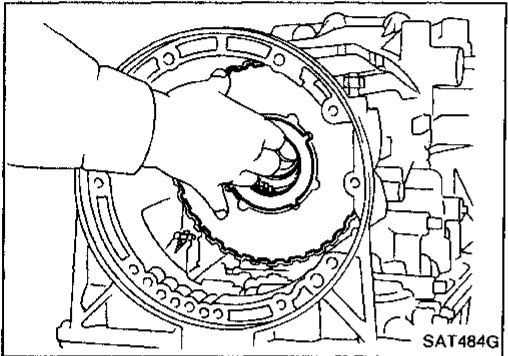

- i. Remove front planetary carrier from transmission case.

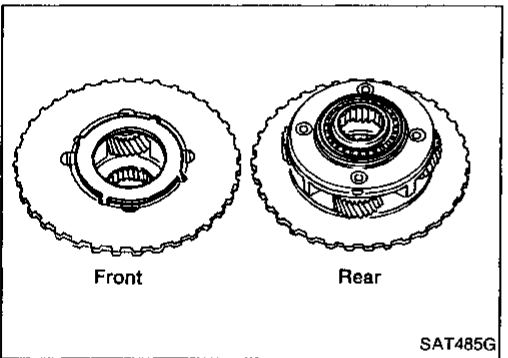

- j. Remove front bearing race from front planetary carrier.
- k. Remove rear needle bearing from front planetary carrier.

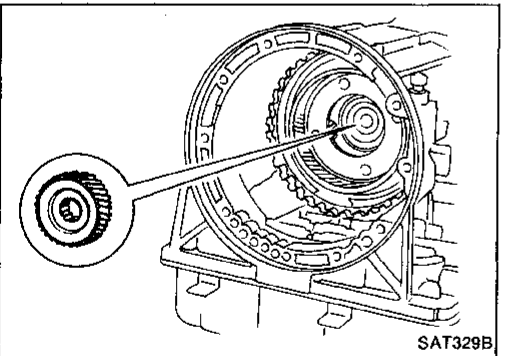

- l. Remove rear sun gear from transmission case.

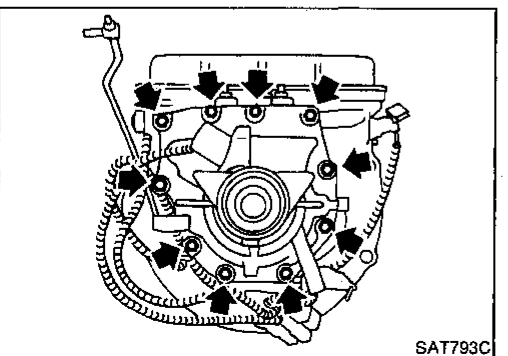

- 18. Remove rear extension.
  - a. Remove rear extension from transmission case.
  - b. Remove rear extension gasket from transmission case.

# DISASSEMBLY

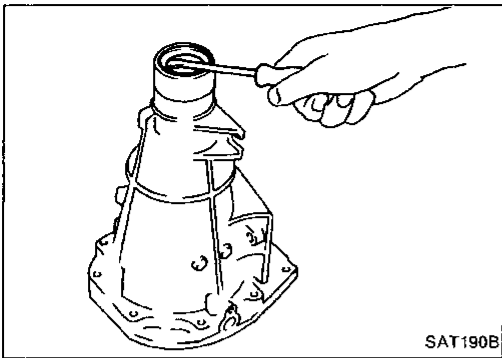

- c. Remove oil seal from rear extension.
- Do not remove oil seal unless it is to be replaced.

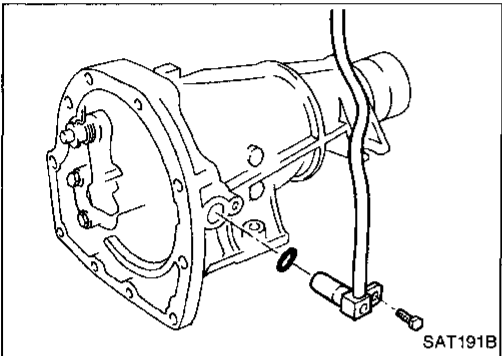

- d. Remove revolution sensor from rear extension.
- e. Remove O-ring from revolution sensor.

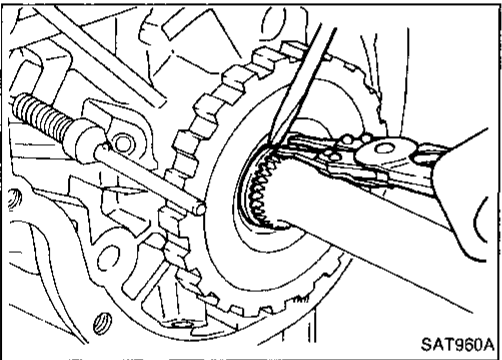

- 19. Remove output shaft and parking gear.
- a. Remove rear snap ring from output shaft.

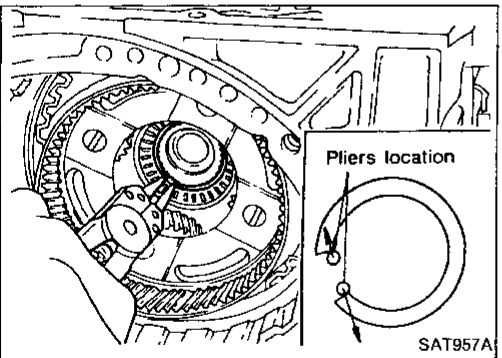

- b. Slowly push output shaft all the way forward.
- Do not use excessive force.
- c. Remove snap ring from output shaft.

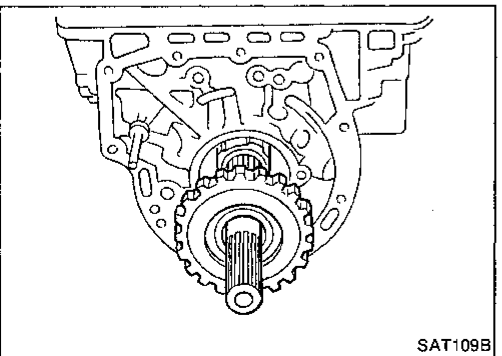

- d. Remove output shaft and parking gear as a unit from transmission case.
- e. Remove parking gear from output shaft.

GI

MA

EM

LC

EF &  
EC

FE

AT

PD

FA

RA

BR

ST

RS

BT

HA

EL

IDX

## DISASSEMBLY

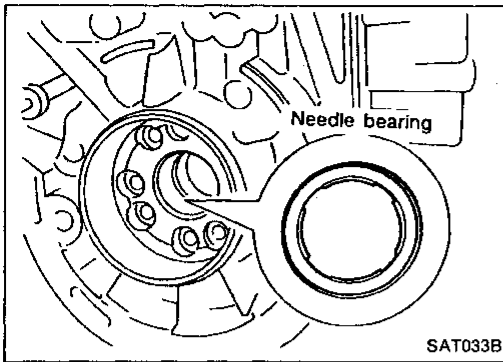

- f. Remove needle bearing from transmission case.

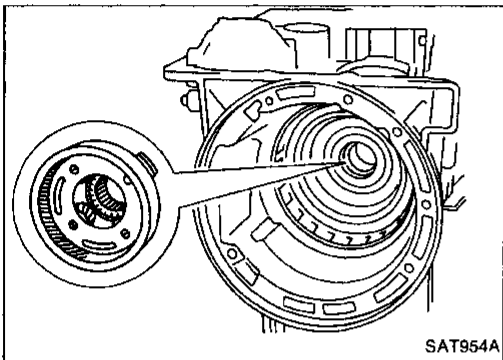

20. Remove rear side clutch and gear components.  
a. Remove front internal gear.

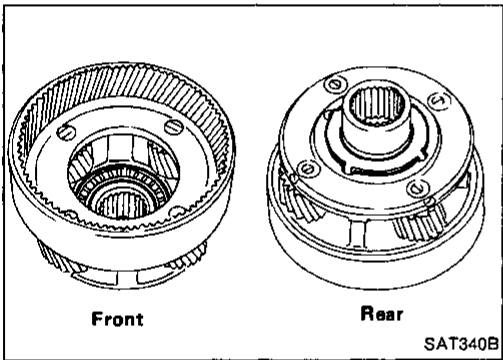

- b. Remove front needle bearing from front internal gear.  
c. Remove rear bearing race from front internal gear.

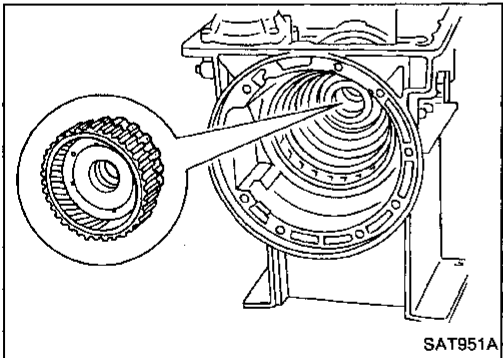

- d. Remove rear internal gear, forward clutch hub and overrun clutch hub as a set from transmission case.

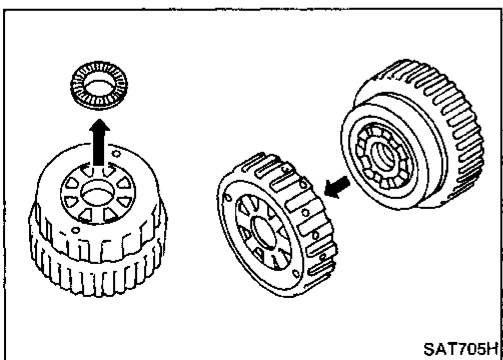

- e. Remove needle bearing from overrun clutch hub.  
f. Remove overrun clutch hub from rear internal gear and forward clutch hub.

# DISASSEMBLY

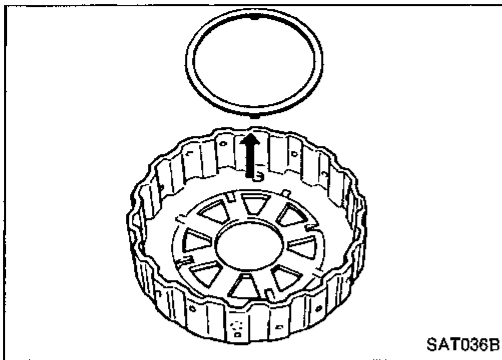

g. Remove thrust washer from overrun clutch hub.

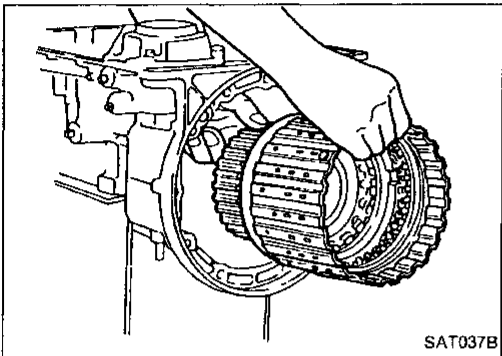

h. Remove forward clutch assembly from transmission case.

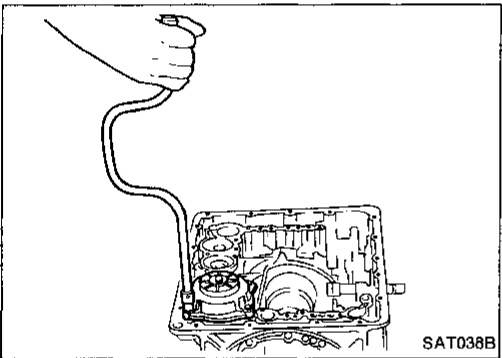

21. Remove band servo and accumulator components.

a. Remove band servo retainer from transmission case.

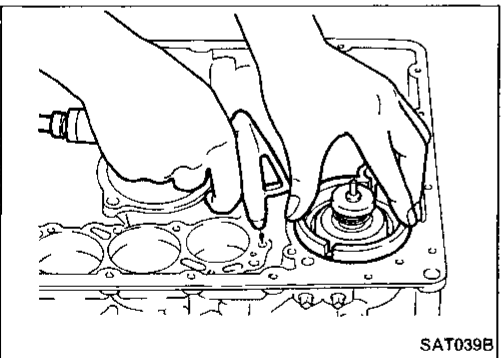

b. Apply compressed air to oil hole until band servo piston comes out of transmission case.

● **Hold piston with a rag and gradually direct air to oil hole.**

c. Remove return spring.

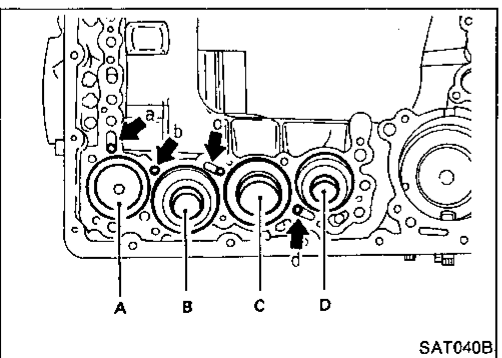

d. Remove springs from accumulator pistons B, C and D.

e. Apply compressed air to each oil hole until piston comes out.

● **Hold piston with a rag and gradually direct air to oil hole.**

Identification of accumulator pistons	A	B	C	D
Identification of oil holes	a	b	c	d

GI

MA

EM

LC

EF &  
EC

FE

**AT**

PD

FA

RA

BR

ST

RS

BT

HA

EL

IDX

## DISASSEMBLY

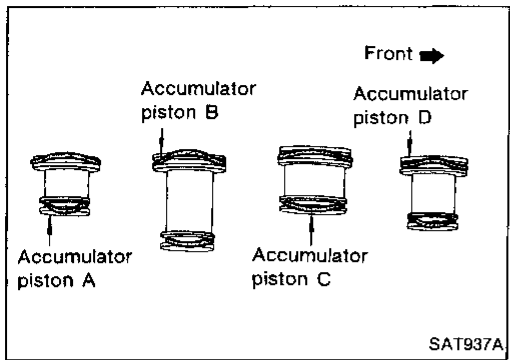

- f. Remove O-ring from each piston.

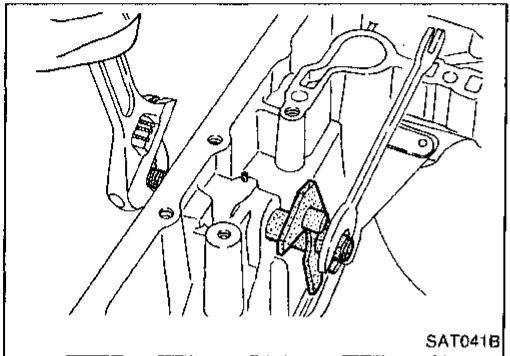

22. Remove manual shaft components, if necessary.
- a. Hold width across flats of manual shaft (outside the transmission case) and remove lock nut from shaft.

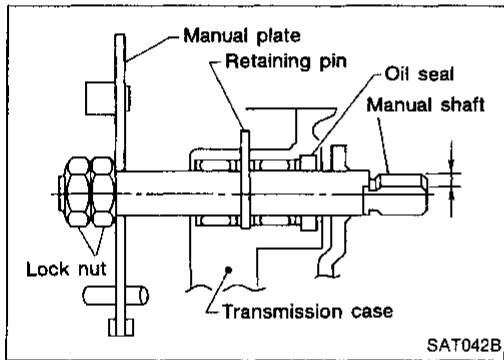

- b. Remove retaining pin from transmission case.

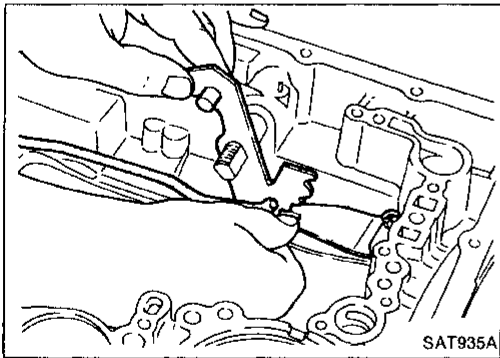

- c. While pushing detent spring down, remove manual plate and parking rod from transmission case.

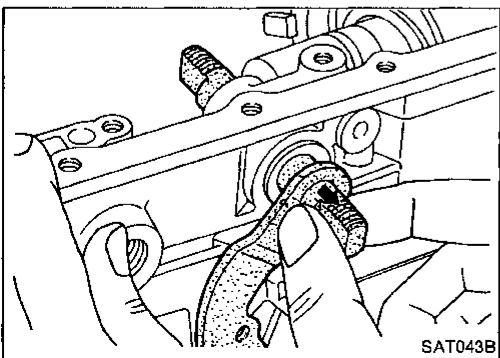

- d. Remove manual shaft from transmission case.

# DISASSEMBLY

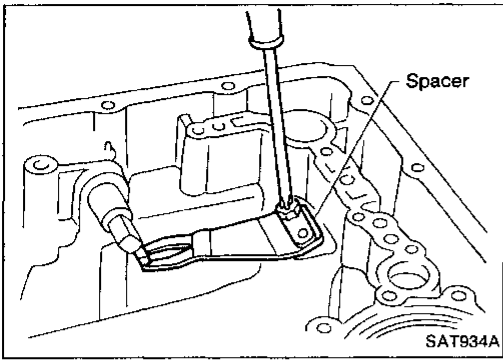

e. Remove spacer and detent spring from transmission case.

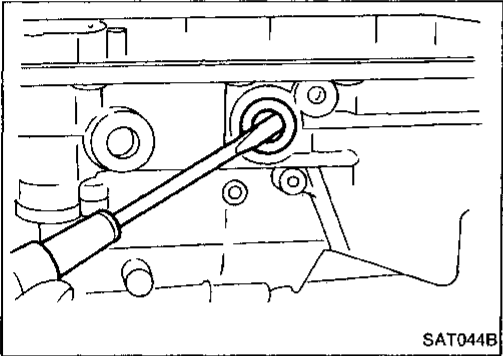

f. Remove oil seal from transmission case.

GI

MA

EM

LC

EF &  
EC

FE

**AT**

PD

FA

RA

BR

ST

RS

BT

HA

EL

IDX

## Oil Pump

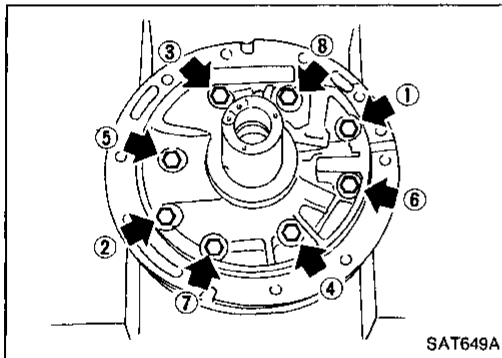
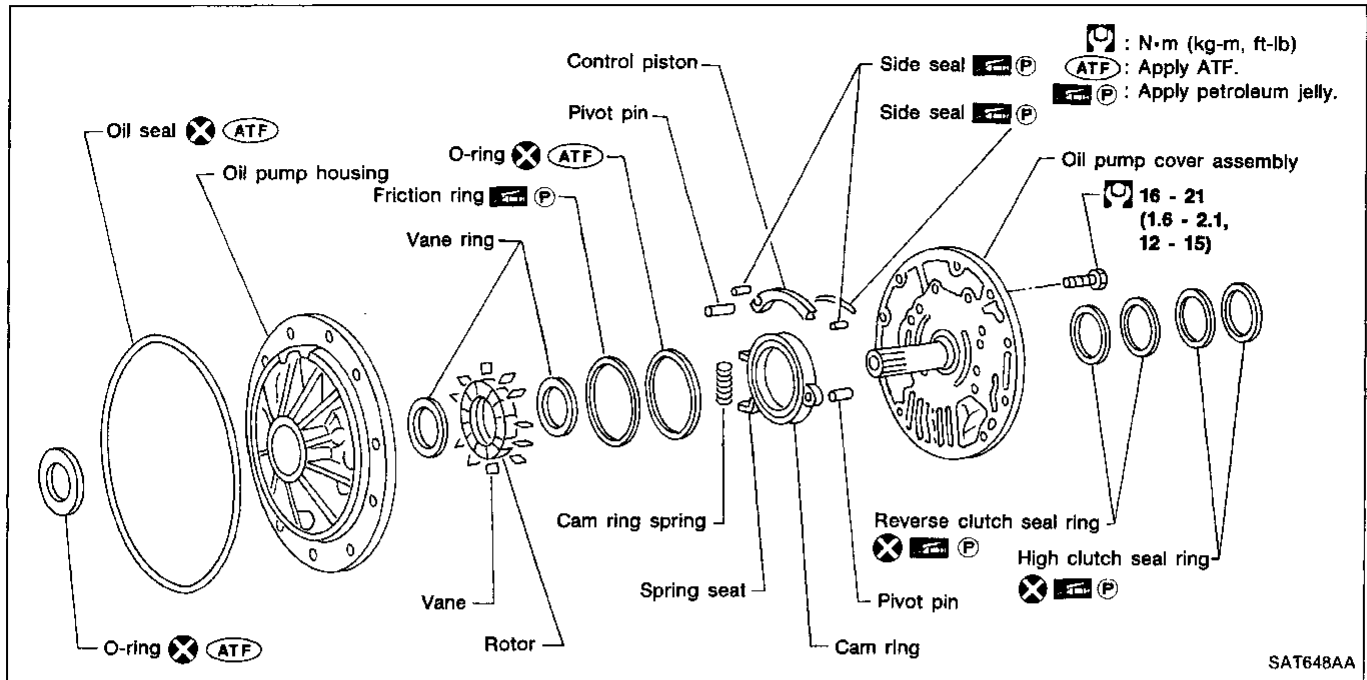

### DISASSEMBLY

1. Loosen bolts in numerical order and remove oil pump cover.

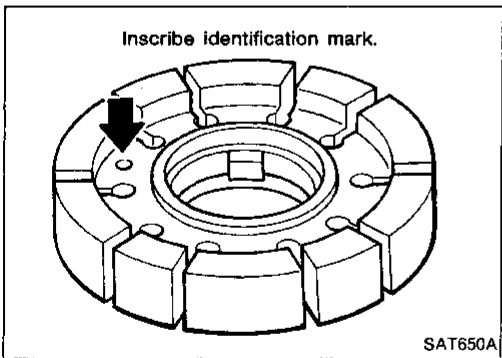

2. Remove rotor, vane rings and vanes.
  - Inscribe a mark on back of rotor for identification of fore-aft direction when reassembling rotor. Then remove rotor.

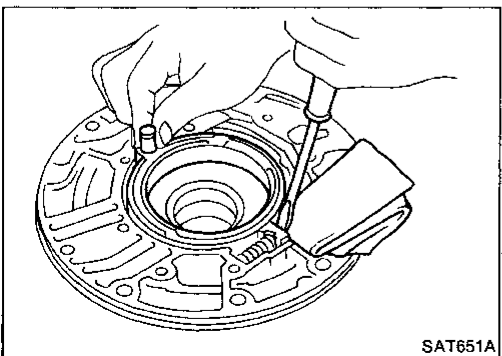

3. While pushing on cam ring remove pivot pin.
  - Be careful not to scratch oil pump housing.



## REPAIR FOR COMPONENT PARTS

### Oil Pump (Cont'd)

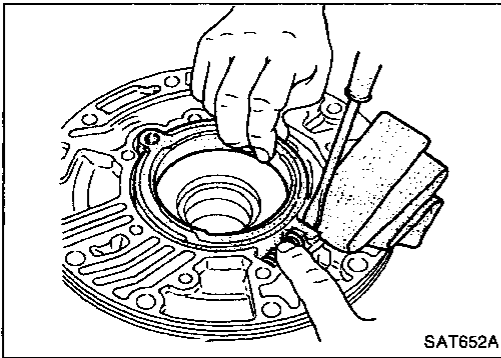

4. While holding cam ring and spring lift out cam ring spring.
  - Be careful not to damage oil pump housing.
  - Hold cam ring spring to prevent it from jumping.

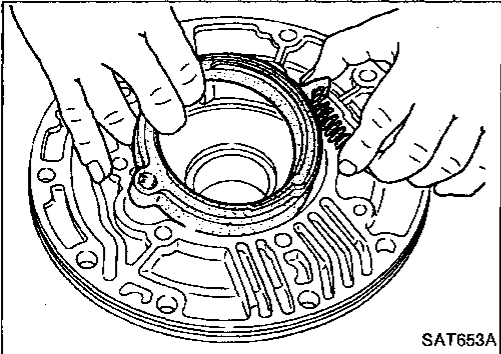

5. Remove cam ring and cam ring spring from oil pump housing.

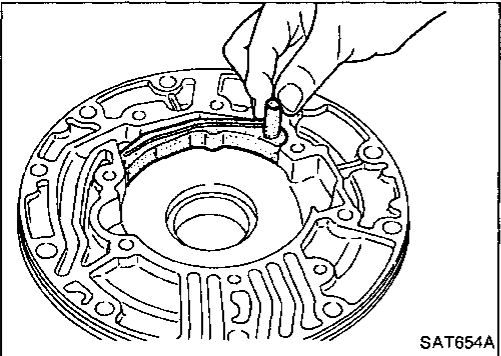

6. Remove pivot pin from control piston and remove control piston assembly.

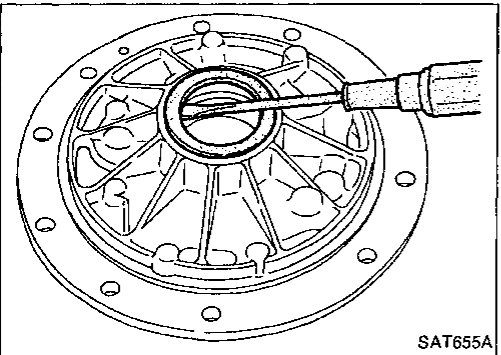

7. Remove oil seal from oil pump housing.
  - Be careful not to scratch oil pump housing.

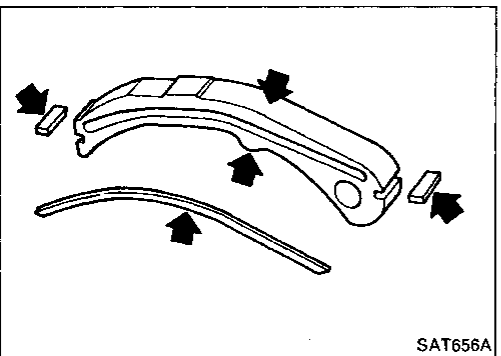

### INSPECTION

Oil pump cover, rotor, vanes, control piston, side seals, cam ring and friction ring

- Check for wear or damage.

GI

MA

EM

LC

EF &  
EC

FE

AT

PD

FA

RA

BR

ST

RS

BT

HA

EL

IDX

## REPAIR FOR COMPONENT PARTS

### Oil Pump (Cont'd)

#### Side clearances

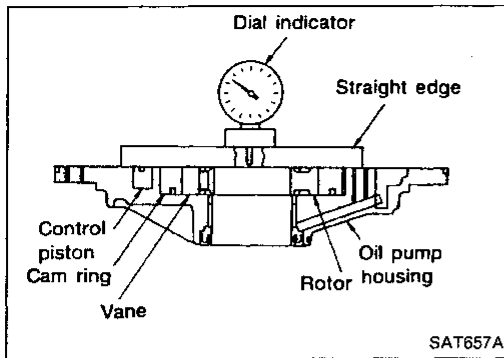

- Measure side clearances between end of oil pump housing and cam ring, rotor, vanes and control piston in at least four places along their circumferences. Maximum measured values should be within specified ranges.
- **Before measuring side clearance, check that friction rings, O-ring, control piston side seals and cam ring spring are removed.**

#### Standard clearance:

##### Cam ring

0.01 - 0.024 mm (0.0004 - 0.0009 in)

##### Rotor, vanes, control piston

0.03 - 0.044 mm (0.0012 - 0.0017 in)

- If not within standard clearance, replace oil pump assembly except oil pump cover assembly.

#### Seal ring clearance

- Measure clearance between seal ring and ring groove.

#### Standard clearance:

0.10 - 0.25 mm (0.0039 - 0.0098 in)

#### Wear limit:

0.25 mm (0.0098 in)

- If not within wear limit, replace oil pump cover assembly.

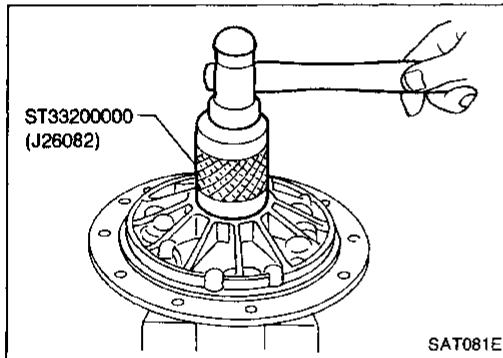
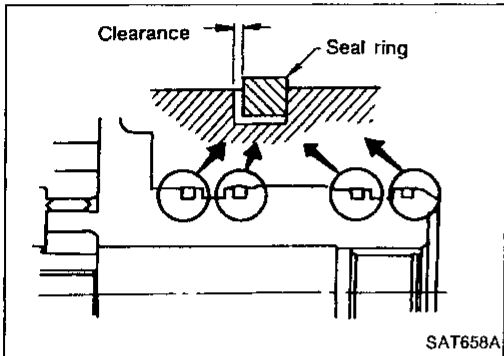

#### ASSEMBLY

1. Drive oil seal into oil pump housing.

- **Apply ATF to outer periphery and lip surface.**

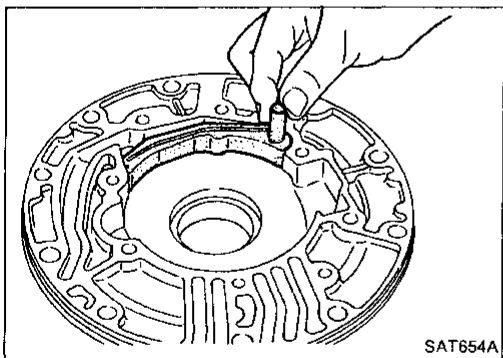

2. Install cam ring in oil pump housing by the following steps.

- a. Install side seal on control piston.

- **Pay attention to its direction — Black surface goes toward control piston.**
- **Apply petroleum jelly to side seal.**

- b. Install control piston on oil pump.

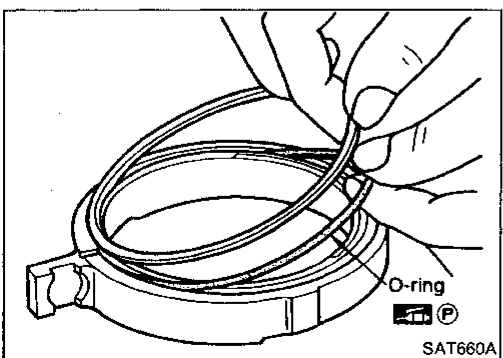

- c. Install O-ring and friction ring on cam ring.

- **Apply petroleum jelly to O-ring.**

# REPAIR FOR COMPONENT PARTS

## Oil Pump (Cont'd)

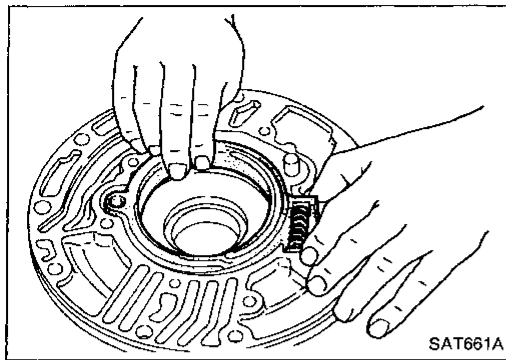

- d. Assemble cam ring, cam ring spring and spring seat. Install spring by pushing it against pump housing.

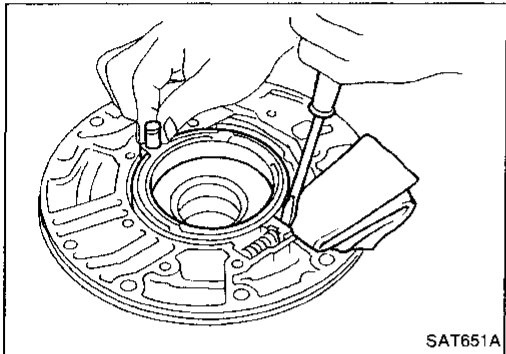

- e. While pushing on cam ring install pivot pin.

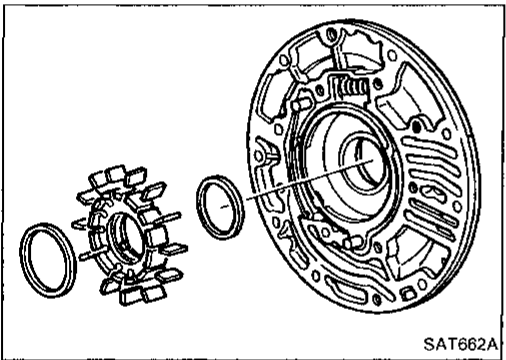

3. Install rotor, vanes and vane rings.  
● Pay attention to direction of rotor.

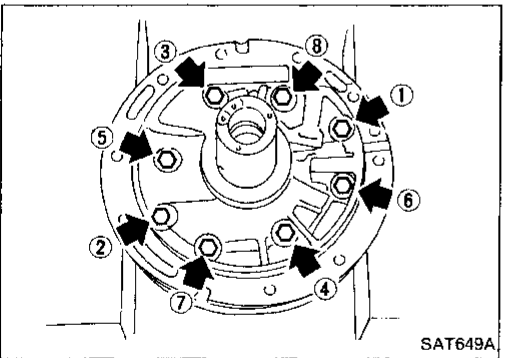

4. Install oil pump housing and oil pump cover.  
a. Wrap masking tape around splines of oil pump cover assembly to protect seal. Position oil pump cover assembly in oil pump housing assembly, then remove masking tape.  
b. Tighten bolts in a criss-cross pattern.

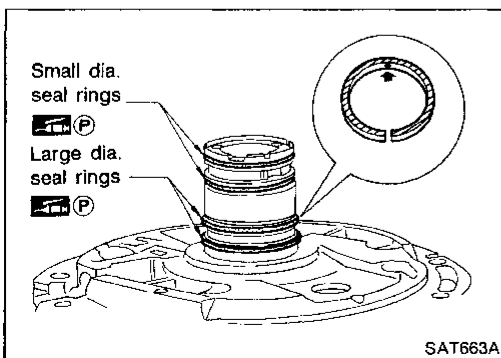

5. Install seal rings carefully after packing ring grooves with petroleum jelly. Press rings down into jelly to a close fit.  
● Seal rings come in two different diameters. Check fit carefully in each groove.  
Small dia. seal ring:  
No mark  
Large dia. seal ring:  
Yellow mark in area shown by arrow  
● Do not spread gap of seal ring excessively while installing. It may deform ring.

GI

MA

EM

LC

EF &  
EC

FE

AT

PD

FA

RA

BR

ST

RS

BT

HA

EL

IDX

Control Valve Assembly

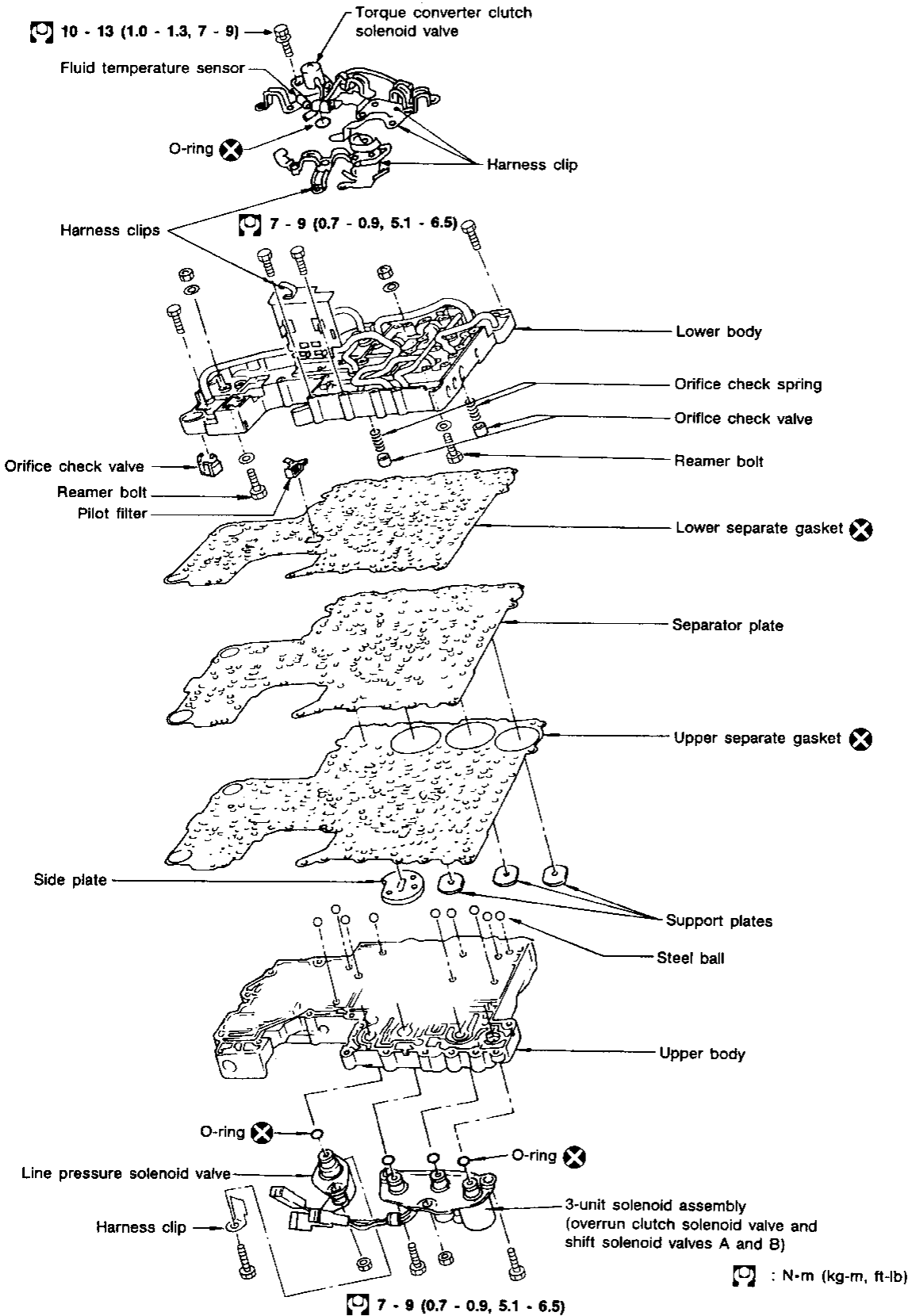

# REPAIR FOR COMPONENT PARTS

## Control Valve Assembly (Cont'd)

### DISASSEMBLY

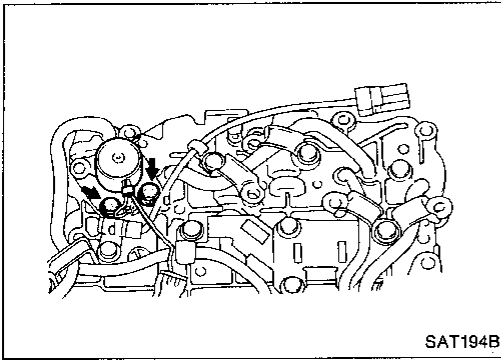

1. Remove solenoids.
  - a. Remove torque converter clutch solenoid valve and side plate from lower body.
  - b. Remove O-ring from solenoid.

GI

MA

EM

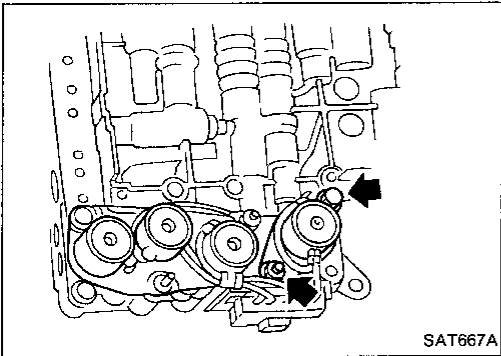

- c. Remove line pressure solenoid valve from upper body.
- d. Remove O-ring from solenoid.

LC

EF &  
EC

FE

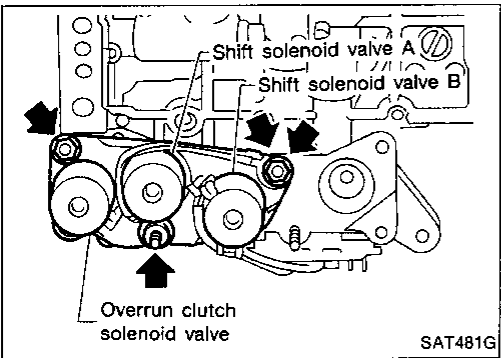

- e. Remove 3-unit solenoid assembly from upper body.
- f. Remove O-rings from solenoids.

AT

PD

FA

RA

BR

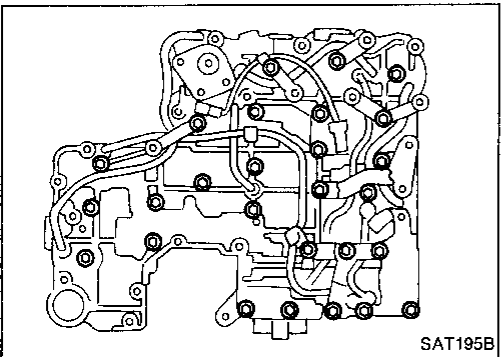

2. Disassemble upper and lower bodies.
  - a. Place upper body facedown, and remove bolts, reamer bolts and support plates.
  - b. Remove lower body, separator plate and separate gasket as a unit from upper body.
  - Be careful not to drop pilot filter, orifice check valve, spring and steel balls.

ST

RS

BT

HA

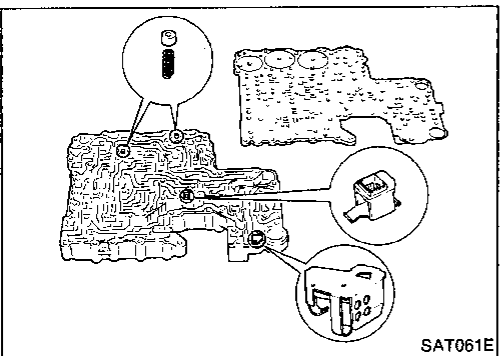

- c. Place lower body facedown, and remove separate gasket and separator plate.
- d. Remove pilot filter, orifice check valves and orifice check springs.

EL

IDX

## REPAIR FOR COMPONENT PARTS

### Control Valve Assembly (Cont'd)

- e. Check to see that steel balls are properly positioned in upper body and then remove them from upper body.

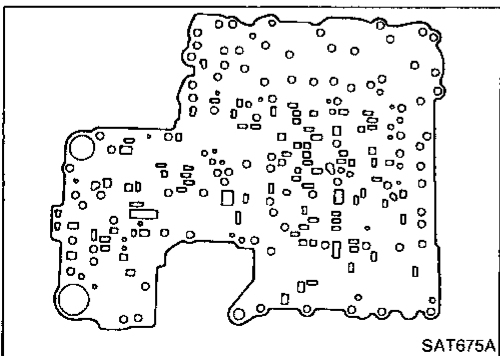
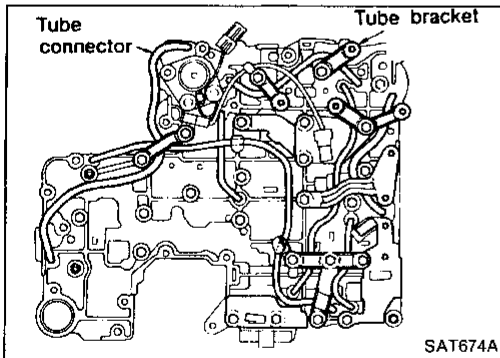
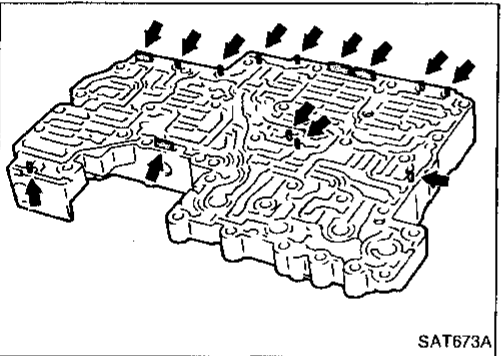
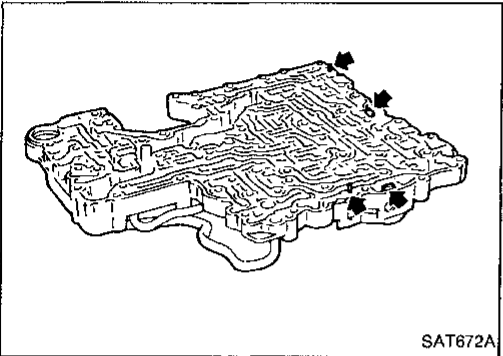
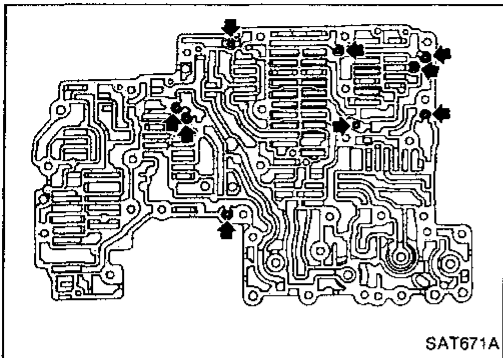

### INSPECTION

#### Lower and upper bodies

- Check to see that there are pins and retainer plates in lower body.

- Check to see that there are pins and retainer plates in upper body.

- **Be careful not to lose these parts.**

- Check to make sure that oil circuits are clean and free from damage.
- Check tube brackets and tube connectors for damage.

#### Separator plates

- Check to make sure that separator plate is free of damage and not deformed and oil holes are clean.

# REPAIR FOR COMPONENT PARTS

## Control Valve Assembly (Cont'd)

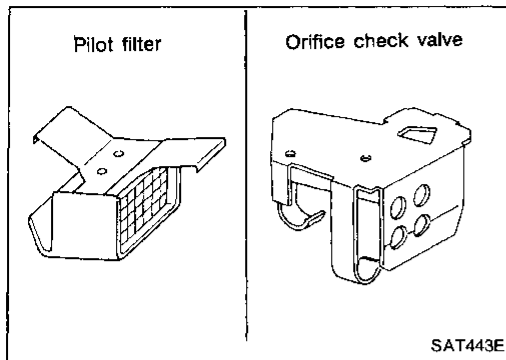

### Pilot filter

- Check to make sure that filter is not clogged or damaged.

### Orifice check valve

- Check that orifice check valve is not damaged.

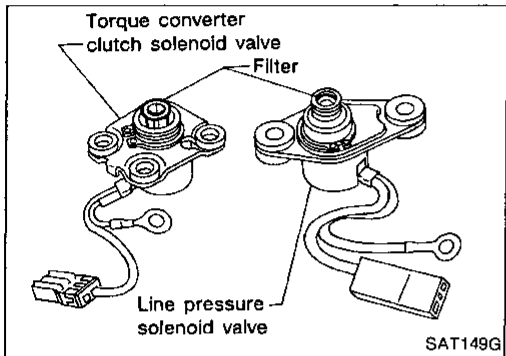

### Torque converter clutch solenoid valve

- Check that filter is not clogged or damaged.
- Measure resistance. — Refer to "Electrical Components Inspection", AT-75.

### Line pressure solenoid valve

- Check that filter is not clogged or damaged.
- Measure resistance. — Refer to "Electrical Components Inspection", AT-75.

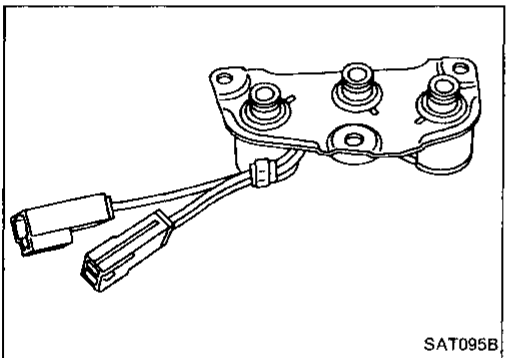

### 3-unit solenoid assembly (Overrun clutch solenoid valve and shift solenoid valves A and B)

- Measure resistance of each solenoid. — Refer to "Electrical Components Inspection", AT-75.

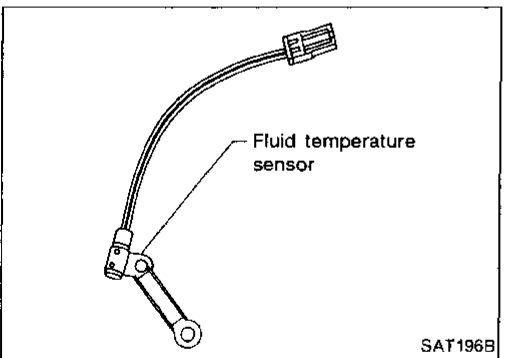

### Fluid temperature sensor

- Measure resistance. — Refer to "Electrical Components Inspection", AT-75.

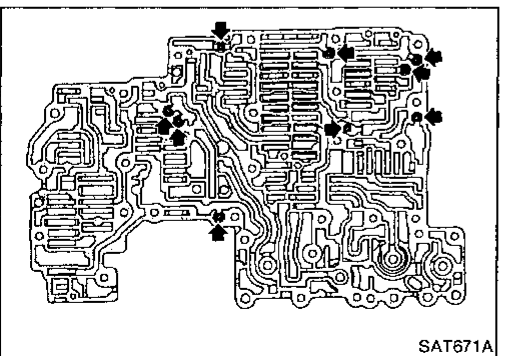

## ASSEMBLY

1. Install upper and lower bodies.
  - a. Place oil circuit of upper body face up. Install steel balls in their proper positions.

GI

MA

EM

LC

EF &  
EC

FE

AT

PD

FA

RA

BR

ST

RS

BT

HA

EL

IDX

## REPAIR FOR COMPONENT PARTS

### Control Valve Assembly (Cont'd)

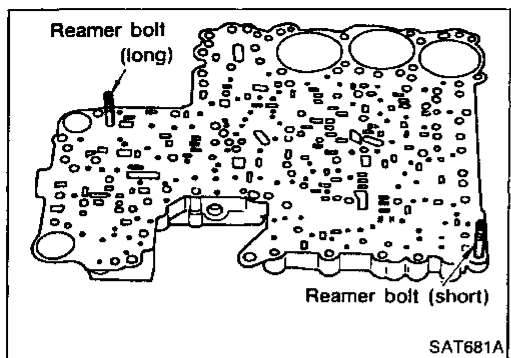

- b. Install reamer bolts from bottom of upper body and install separate gaskets.

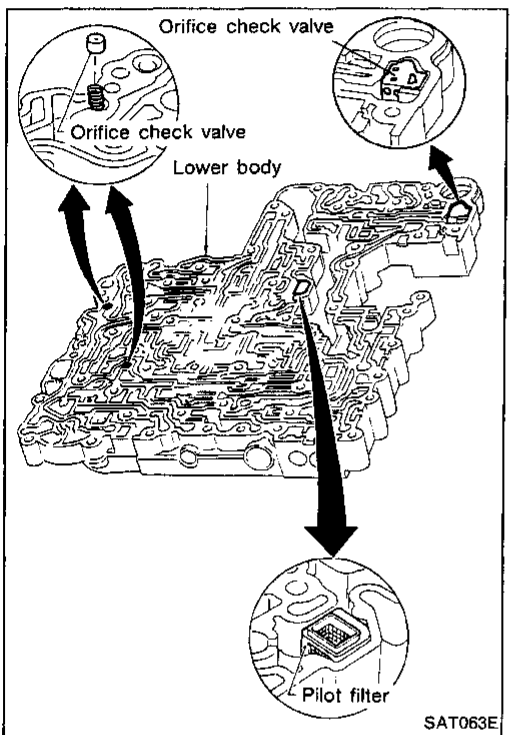

- c. Place oil circuit of lower body face up. Install orifice check springs, orifice check valves and pilot filter.

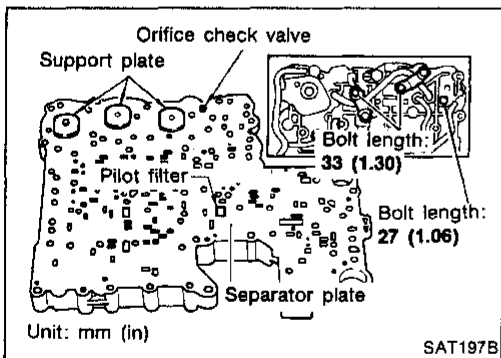

- d. Install lower separate gaskets and separator plates on lower body.
- e. Install and temporarily tighten support plates, fluid temperature sensor and tube brackets.

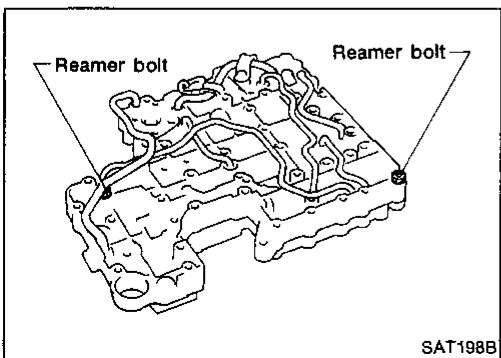

- f. Temporarily assemble lower and upper bodies, using reamer bolt as a guide.
- Be careful not to dislocate or drop steel balls, orifice check spring, orifice check valve and pilot filter.



# REPAIR FOR COMPONENT PARTS

## Control Valve Assembly (Cont'd)

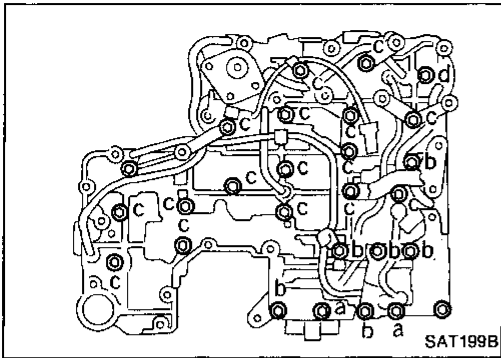

- g. Install and temporarily tighten bolts and tube brackets in their proper locations.

### Bolt length and location:

Item	mm (in)	Bolt symbol			
		a	b	c	d
Bolt length		70 (2.76)	50 (1.97)	33 (1.30)	27 (1.06)

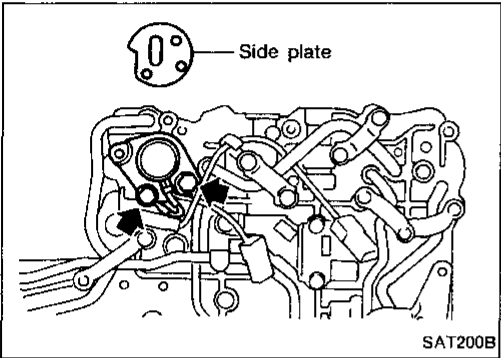

2. Install solenoids.  
a. Attach O-ring and install torque converter clutch solenoid valve and side plates onto lower body.

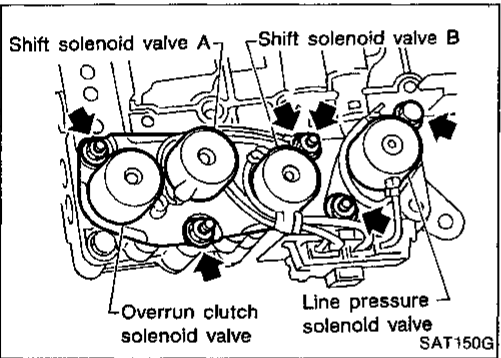

- b. Attach O-rings and install 3-unit solenoids assembly onto upper body.  
c. Attach O-ring and install line pressure solenoid valve onto upper body.  
3. Tighten all bolts.

GI

MA

EM

LC

EF &  
EC

FE

AT

PD

FA

RA

BR

ST

RS

BT

HA

EL

IDX

Control Valve Upper Body

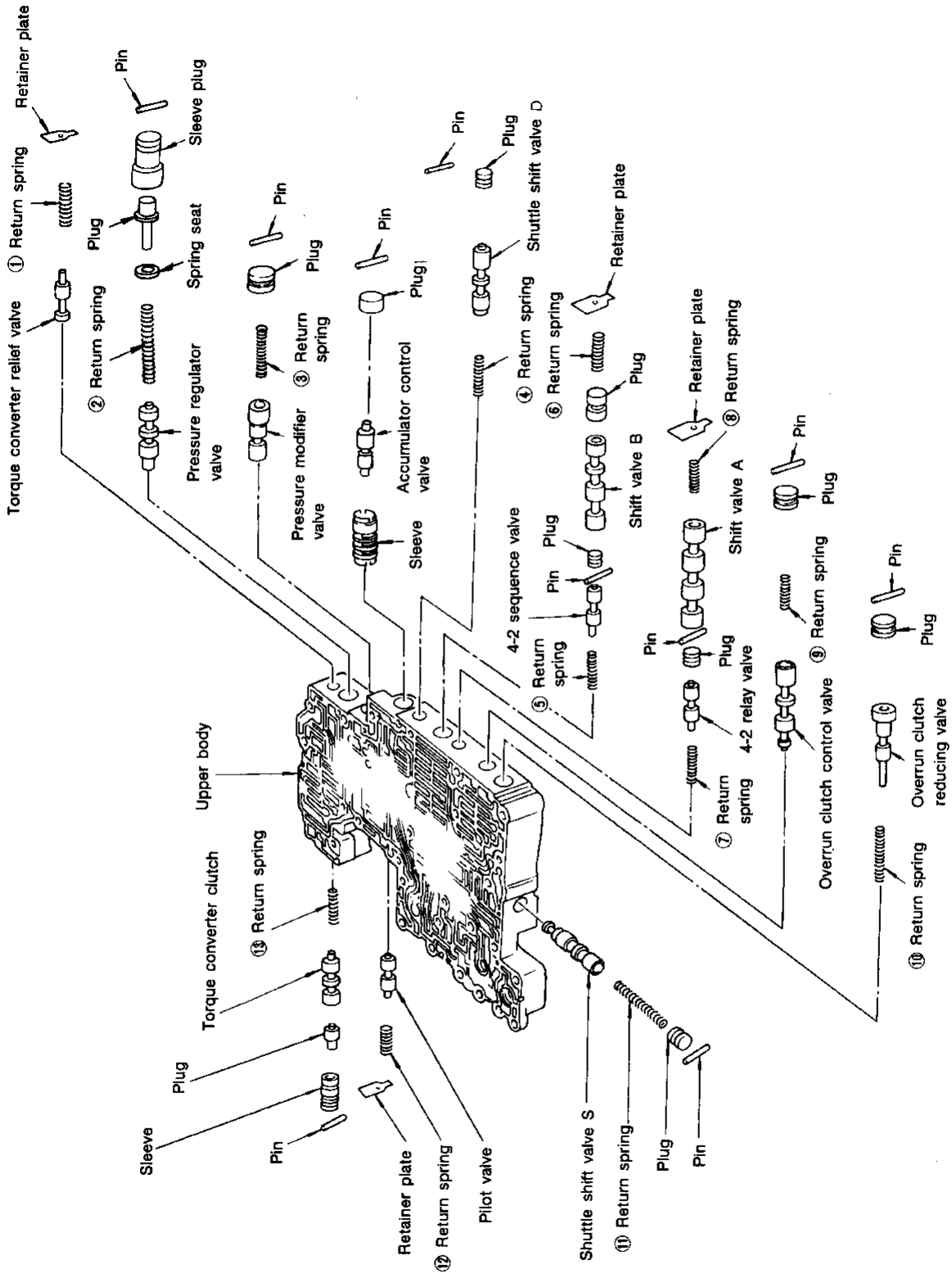

Number preceding valve spring correspond with those shown in Spring Chart on page AT -141.

Apply ATF to all components before their installation.

SAT996G

## REPAIR FOR COMPONENT PARTS

### Control Valve Upper Body (Cont'd)

#### DISASSEMBLY

1. Remove valves at parallel pins.

- Do not use a magnetic hand.

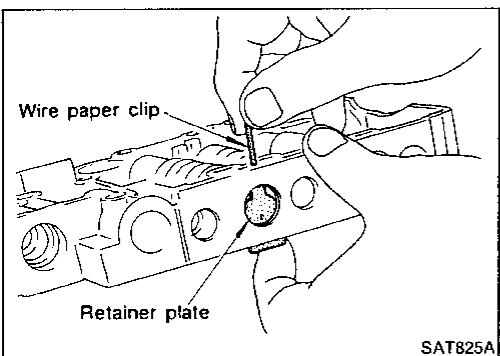
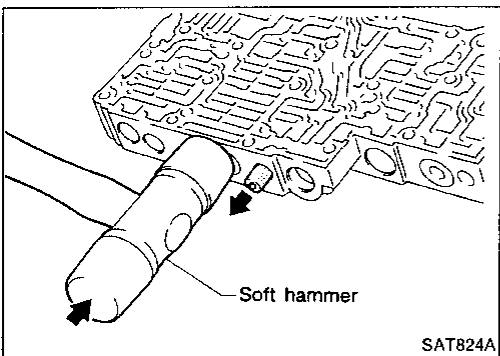
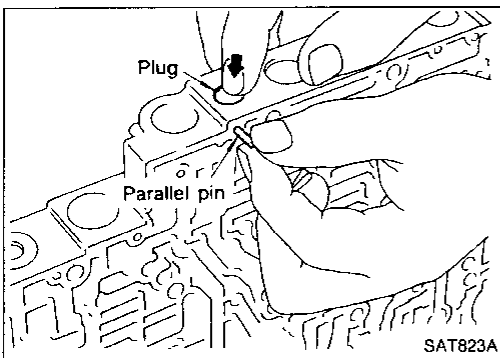
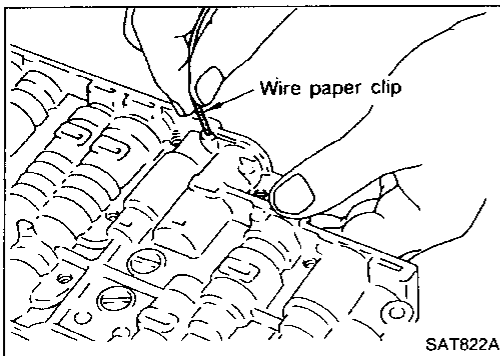
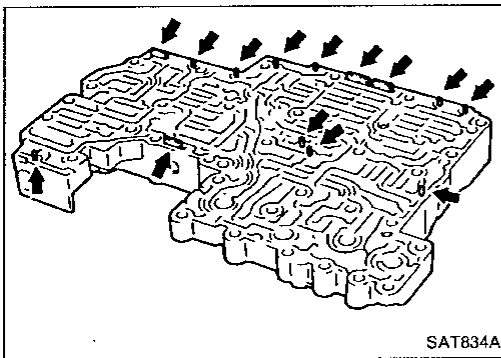

a. Use a wire paper clip to push out parallel pins.

b. Remove parallel pins while pressing their corresponding plugs and sleeves.

- Remove plug slowly to prevent internal parts from jumping out.

c. Place mating surface of valve facedown, and remove internal parts.

- If a valve is hard to remove, place valve body facedown and lightly tap it with a soft hammer.
- Be careful not to drop or damage valves and sleeves.

2. Remove valves at retainer plates.

a. Pry out retainer plate with wire paper clip.

GI

MA

EM

LC

EF &  
EC

FE

AT

PD

FA

RA

BR

ST

RS

BT

HA

EL

IDX

## REPAIR FOR COMPONENT PARTS

### Control Valve Upper Body (Cont'd)

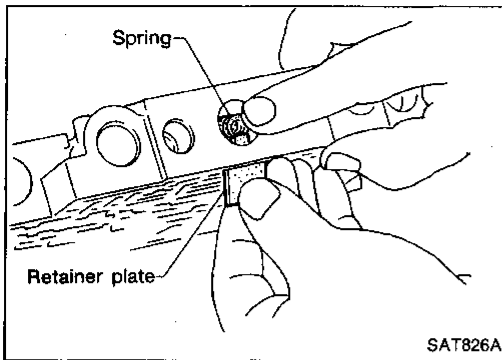

b. Remove retainer plates while holding spring.

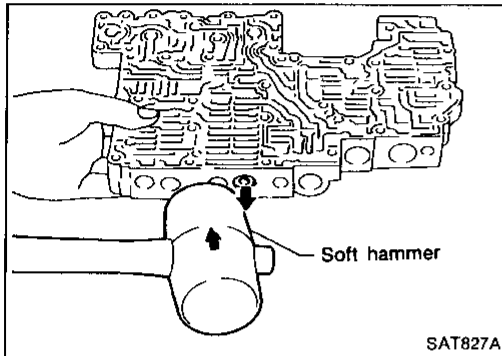

c. Place mating surface of valve facedown, and remove internal parts.

- If a valve is hard to remove, lightly tap valve body with a soft hammer.
- Be careful not to drop or damage valves, sleeves, etc.

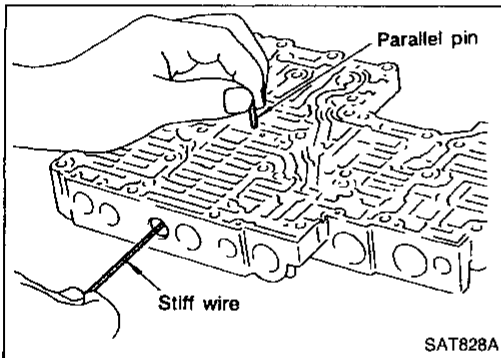

- 4-2 sequence valve and relay valve are located far back in upper body. If they are hard to remove, carefully push them out using stiff wire.
- Be careful not to scratch sliding surface of valve with wire.

# REPAIR FOR COMPONENT PARTS

## Control Valve Upper Body (Cont'd)

### INSPECTION

#### Valve springs

- Measure free length and outer diameter of each valve spring. Also check for damage or deformation.
- Numbers of each valve spring listed in table below are the same as those in the figure on AT-138.

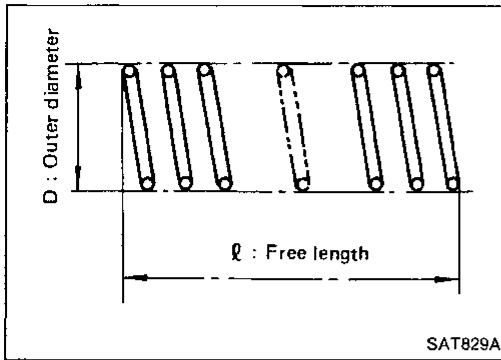

SAT829A

### Inspection standard

Unit: mm (in)

Parts	Item		
	Part No.	ℓ	D
① Torque converter relief valve spring	31742-41X23	38.0 (1.496)	9.0 (0.354)
② Pressure regulator valve spring	31742-41X24	44.02 (1.7331)	14.0 (0.551)
③ Pressure modifier valve spring	31742-41X19	31.95 (1.2579)	6.8 (0.268)
④ Shuttle shift valve D spring	31762-41X00	26.5 (1.043)	6.0 (0.236)
⑤ 4-2 sequence valve spring	31756-41X00	29.1 (1.146)	6.95 (0.2736)
⑥ Shift valve B spring	31762-41X01	25.0 (0.984)	7.0 (0.276)
⑦ 4-2 relay valve spring	31756-41X00	29.1 (1.146)	6.95 (0.2736)
⑧ Shift valve A spring	31762-41X01	25.0 (0.984)	7.0 (0.276)
⑨ Overrun clutch control valve spring	31762-41X03	23.6 (0.929)	7.0 (0.276)
⑩ Overrun clutch reducing valve spring	31742-41X14	38.9 (1.531)	7.0 (0.276)
⑪ Shuttle shift valve S spring	31762-41X04	51.0 (2.008)	5.65 (0.2224)
⑫ Pilot valve spring	31742-41X13	25.7 (1.012)	9.1 (0.358)
⑬ Torque converter clutch control valve spring	31742-41X22	18.5 (0.728)	13.0 (0.512)

- Replace valve springs if deformed or fatigued.

#### Control valves

- Check sliding surfaces of valves, sleeves and plugs.

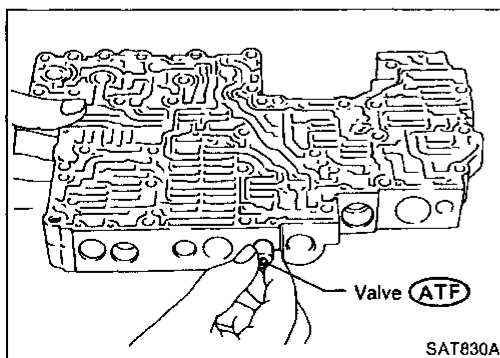

### ASSEMBLY

1. Lubricate the control valve body and all valves with ATF. Install control valves by sliding them carefully into their bores.
- Be careful not to scratch or damage valve body.

## REPAIR FOR COMPONENT PARTS

### Control Valve Upper Body (Cont'd)

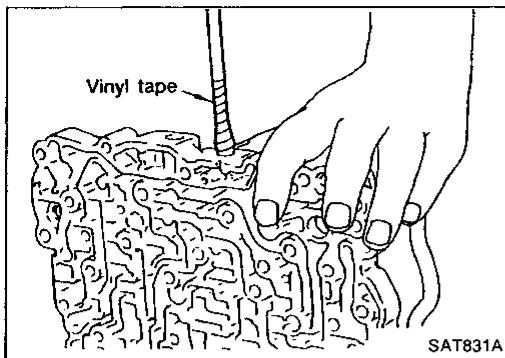

- Wrap a small screwdriver with vinyl tape and use it to insert the valves into proper position.

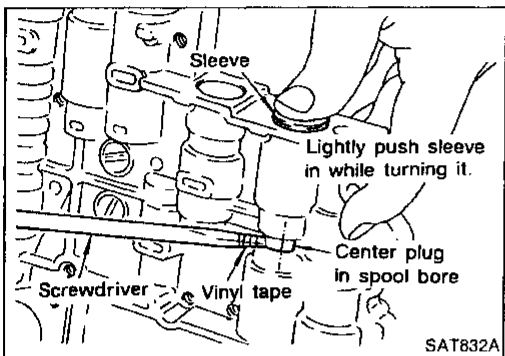

### Pressure regulator valve

- If pressure regulator plug is not centered properly, sleeve cannot be inserted into bore in upper body. If this happens, use vinyl tape wrapped screwdriver to center sleeve until it can be inserted.
- Turn sleeve slightly while installing.

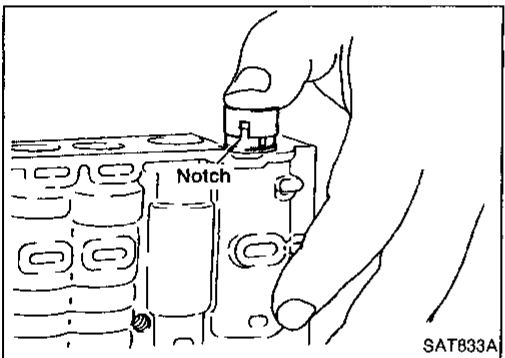

### Accumulator control plug

- Align protrusion of accumulator control sleeve with notch in plug.
- Align parallel pin groove in plug with parallel pin, and install accumulator control valve.

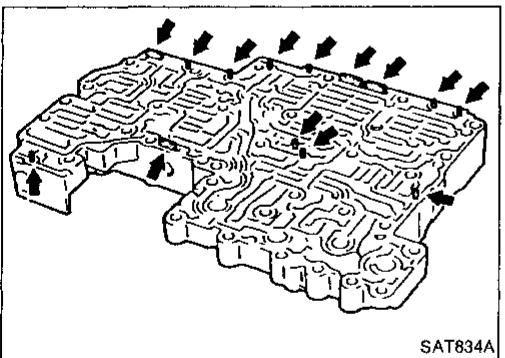

2. Install parallel pins and retainer plates.

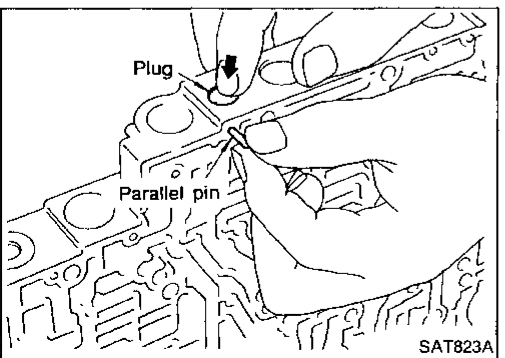

- While pushing plug, install parallel pin.

## REPAIR FOR COMPONENT PARTS

### Control Valve Upper Body (Cont'd)

#### 4-2 sequence valve and relay valve

- Push 4-2 sequence valve and relay valve with wire wrapped in vinyl tape to prevent scratching valve body. Install parallel pins.

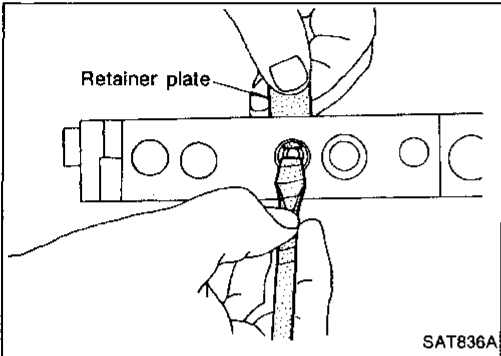
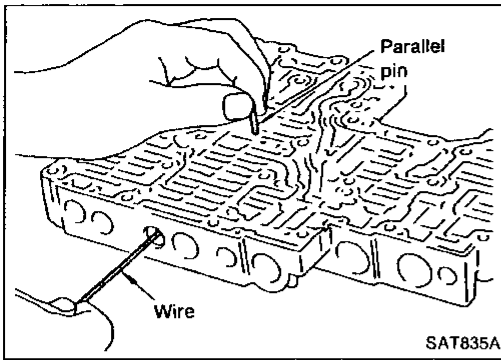

- Insert retainer plate while pushing spring.

GI

MA

EM

LC

EF &  
EC

FE

**AT**

PD

FA

RA

BR

ST

RS

BT

HA

EL

IDX

Control Valve Lower Body

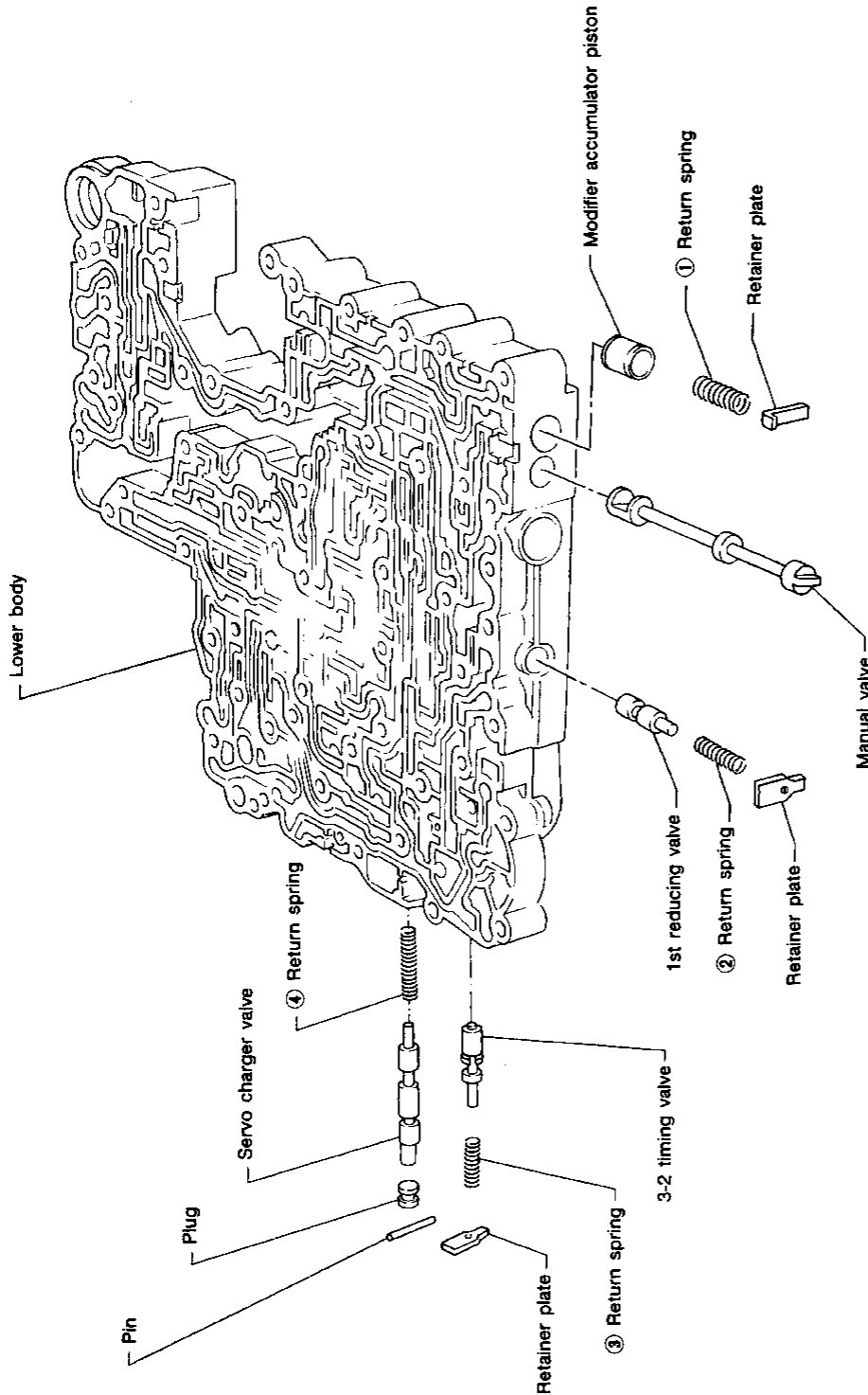

Numbers preceding valve springs correspond with those shown in Spring Chart on the next page.  
Apply ATF to all components before their installation.

SAT997GA



# REPAIR FOR COMPONENT PARTS

## Control Valve Lower Body (Cont'd)

### DISASSEMBLY

1. Remove valves at parallel pins.
  2. Remove valves at retainer plates.
- For removal procedures, refer to "DISASSEMBLY" in "Control Valve Upper Body", AT-139.

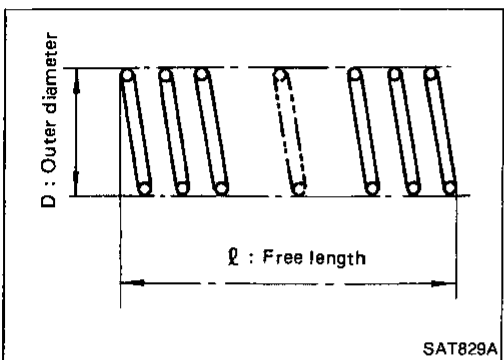
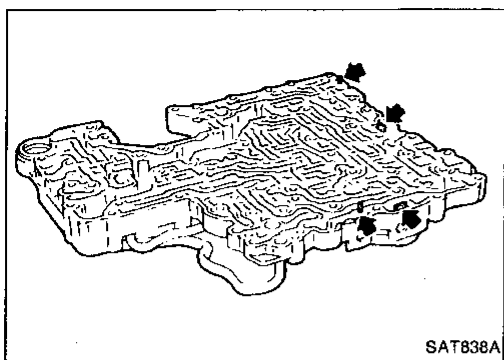

### INSPECTION

#### Valve springs

- Check each valve spring for damage or deformation. Also measure free length and outer diameter.
- Numbers of each valve spring listed in table below are the same as those in the figure on AT-144.

### Inspection standard:

Unit: mm (in)

Parts	Item		
	Part No.	ℓ	D
① Modifier accumulator piston spring	31742-27X70	31.4 (1.236)	9.8 (0.386)
② 1st reducing valve spring	31756-60X00	29.5 (1.161)	7.0 (0.276)
③ 3-2 timing valve spring	31742-41X08	20.55 (0.8091)	6.75 (0.2657)
④ Servo charger valve spring	31742-41X06	23.0 (0.906)	6.7 (0.264)

- Replace valve springs if deformed or fatigued.

### Control valves

- Check sliding surfaces of control valves, sleeves and plugs for damage.

### ASSEMBLY

- Install control valves.
- For installation procedures, refer to "ASSEMBLY" in "Control Valve Upper Body", AT-141.

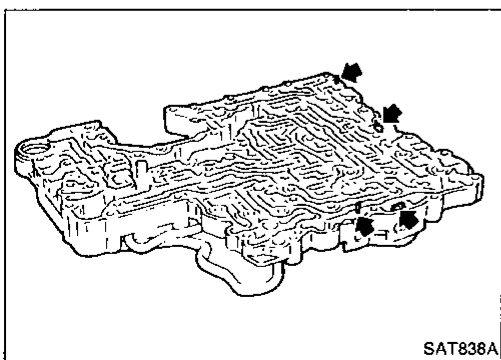

Reverse Clutch

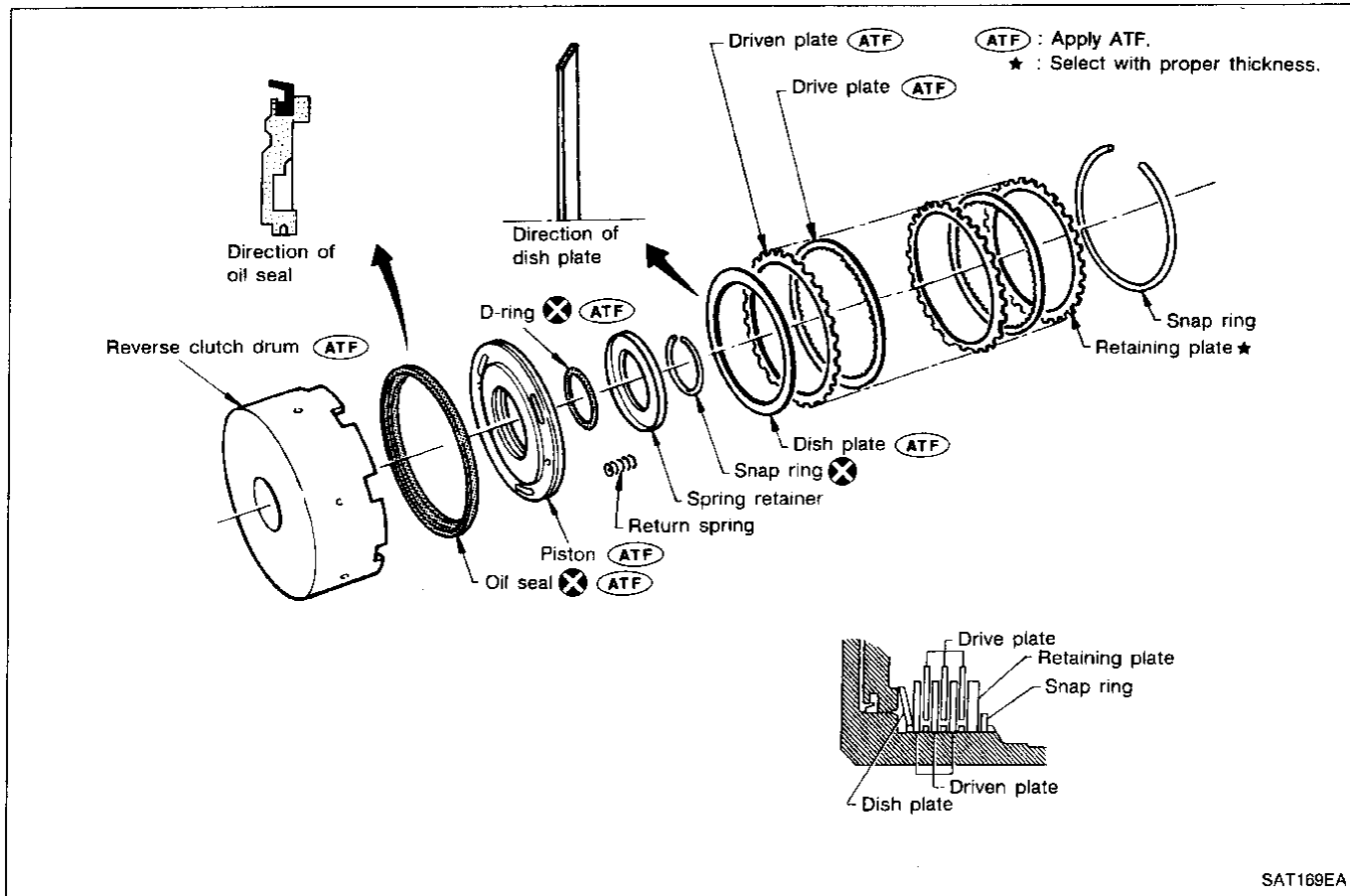

SAT169EA

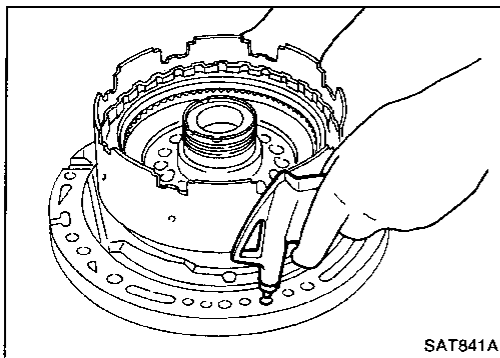

SAT841A

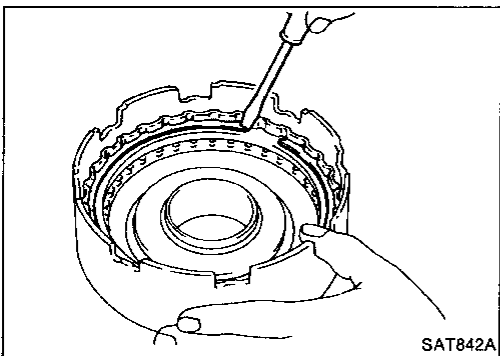

SAT842A

**DISASSEMBLY**

1. Check operation of reverse clutch.
  - a. Install seal ring onto oil pump cover and install reverse clutch. Apply compressed air to oil hole.
  - b. Check to see that retaining plate moves to snap ring.
  - c. If retaining plate does not contact snap ring,
    - D-ring might be damaged.
    - Oil seal might be damaged.
    - Fluid might be leaking past piston check ball.
  
2. Remove drive plates, driven plates, retaining plate, dish plate and snap ring.

# REPAIR FOR COMPONENT PARTS

## Reverse Clutch (Cont'd)

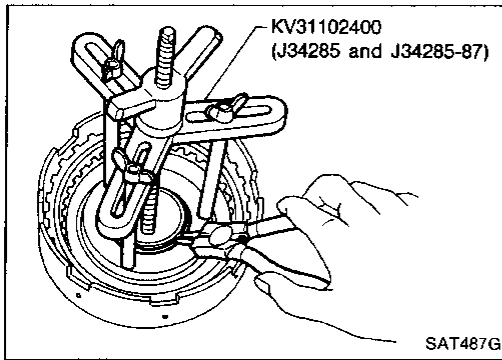

3. Remove snap ring from clutch drum while compressing clutch springs.
- Do not expand snap ring excessively.
4. Remove spring retainer and return spring.

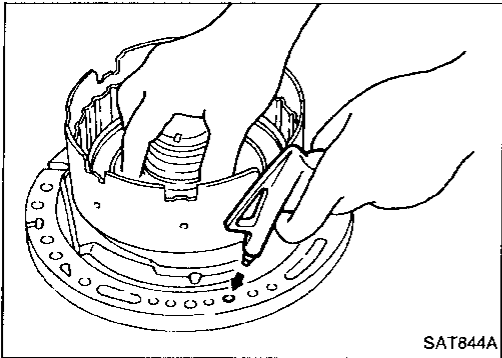

5. Install seal ring onto oil pump cover and install reverse clutch drum. While holding piston, gradually apply compressed air to oil hole until piston is removed.
- Do not apply compressed air abruptly.
6. Remove D-ring and oil seal from piston.

## INSPECTION

### Reverse clutch snap ring and spring retainer

- Check for deformation, fatigue or damage.

### Reverse clutch return springs

- Check for deformation or damage. Also measure free length and outside diameter.

#### Inspection standard:

Unit: mm (in)

Parts	Part No.	ℓ	D
Spring	31505-51X00	37.18 (1.4638)	14.8 (0.583)

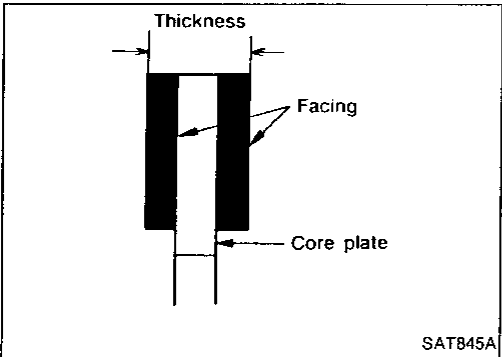
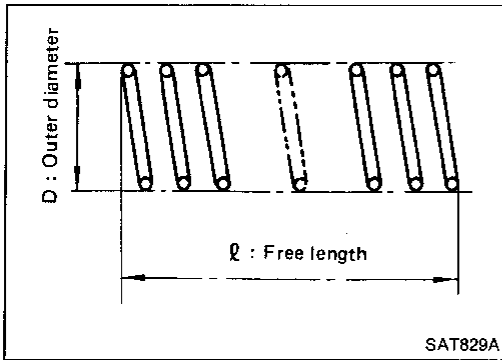

### Reverse clutch drive plates

- Check facing for burns, cracks or damage.
- Measure thickness of facing.

#### Thickness of drive plate:

Standard value: 1.90 - 2.05 mm (0.0748 - 0.0807 in)

Wear limit: 1.8 mm (0.071 in)

- If not within wear limit, replace.

### Reverse clutch dish plate

- Check for deformation or damage.

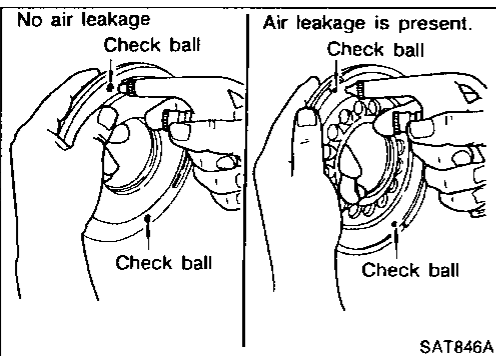

### Reverse clutch piston

- Shake piston to assure that balls are not seized.
- Apply compressed air to check ball oil hole opposite the return spring to assure that there is no air leakage.
- Also apply compressed air to oil hole on return spring side to assure that air leaks past ball.

## REPAIR FOR COMPONENT PARTS

### Reverse Clutch (Cont'd)

#### ASSEMBLY

1. Install D-ring and oil seal on piston.
  - Apply ATF to both parts.

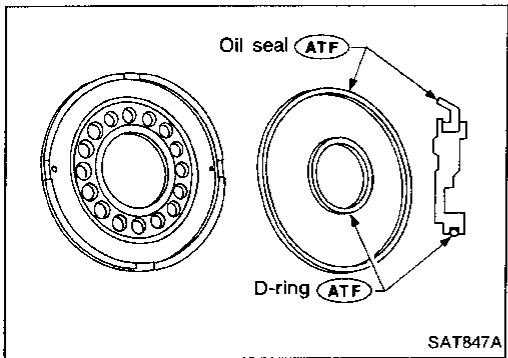

2. Install piston assembly by turning it slowly and evenly.
  - Apply ATF to inner surface of drum.

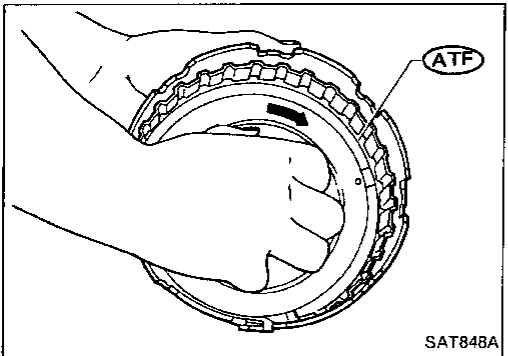

3. Install return springs and spring retainer.

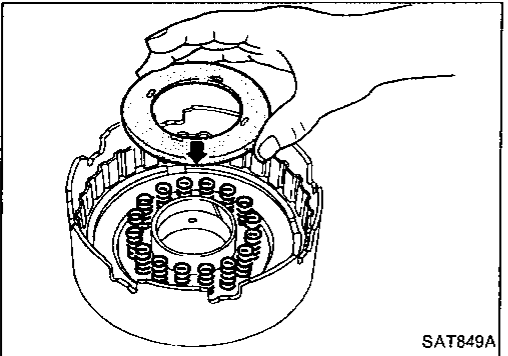

4. Install snap ring while compressing clutch springs.

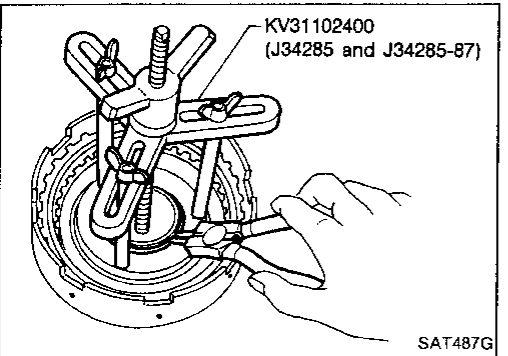

- Do not align snap ring gap with spring retainer stopper.

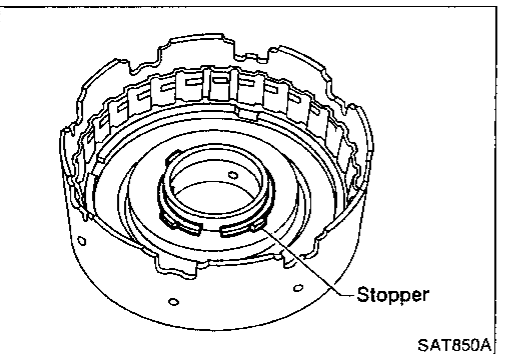

# REPAIR FOR COMPONENT PARTS

## Reverse Clutch (Cont'd)

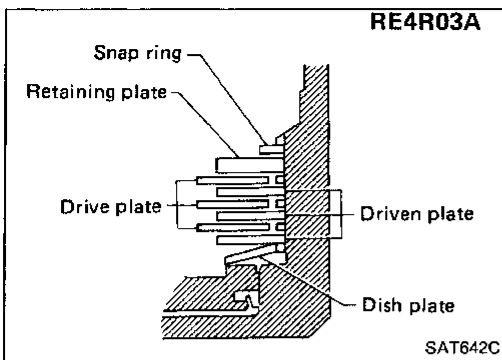

5. Install drive plates, driven plates, retaining plate and dish plate.

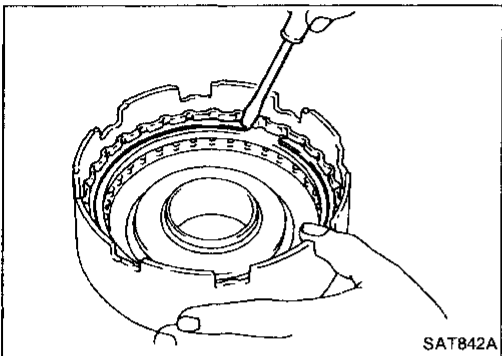

6. Install snap ring.

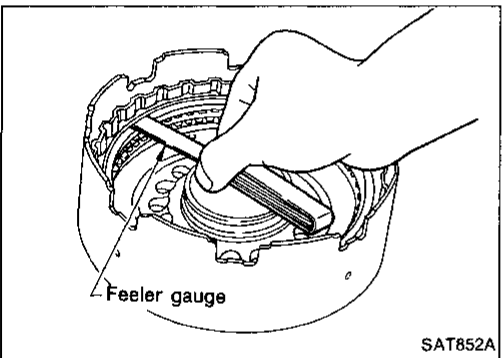

7. Measure clearance between retaining plate and snap ring. If not within allowable limit, select proper retaining plate.

**Specified clearance:**

**Standard**

0.6 - 0.9 mm (0.024 - 0.035 in)

**Allowable limit**

1.4 mm (0.055 in)

**Retaining plate:**

Refer to SDS, AT-191.

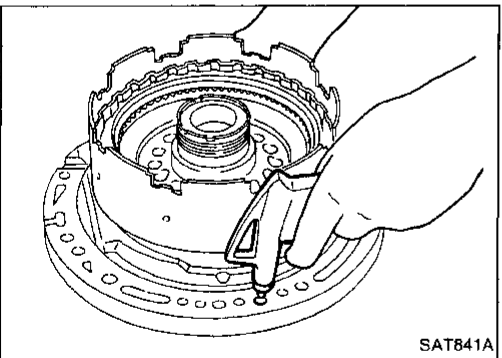

8. Check operation of reverse clutch. Refer to "DISASSEMBLY" in "Reverse Clutch", AT-146.

GI

MA

EM

LC

EF &  
EC

FE

AT

PD

FA

RA

BR

ST

RS

BT

HA

EL

IDX

High Clutch

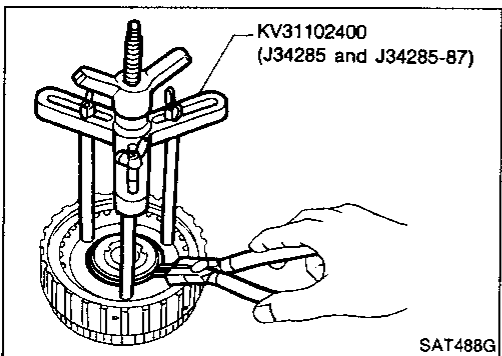
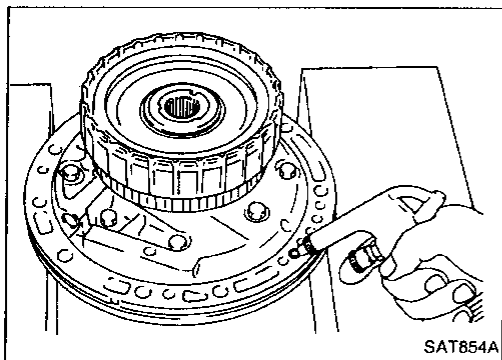
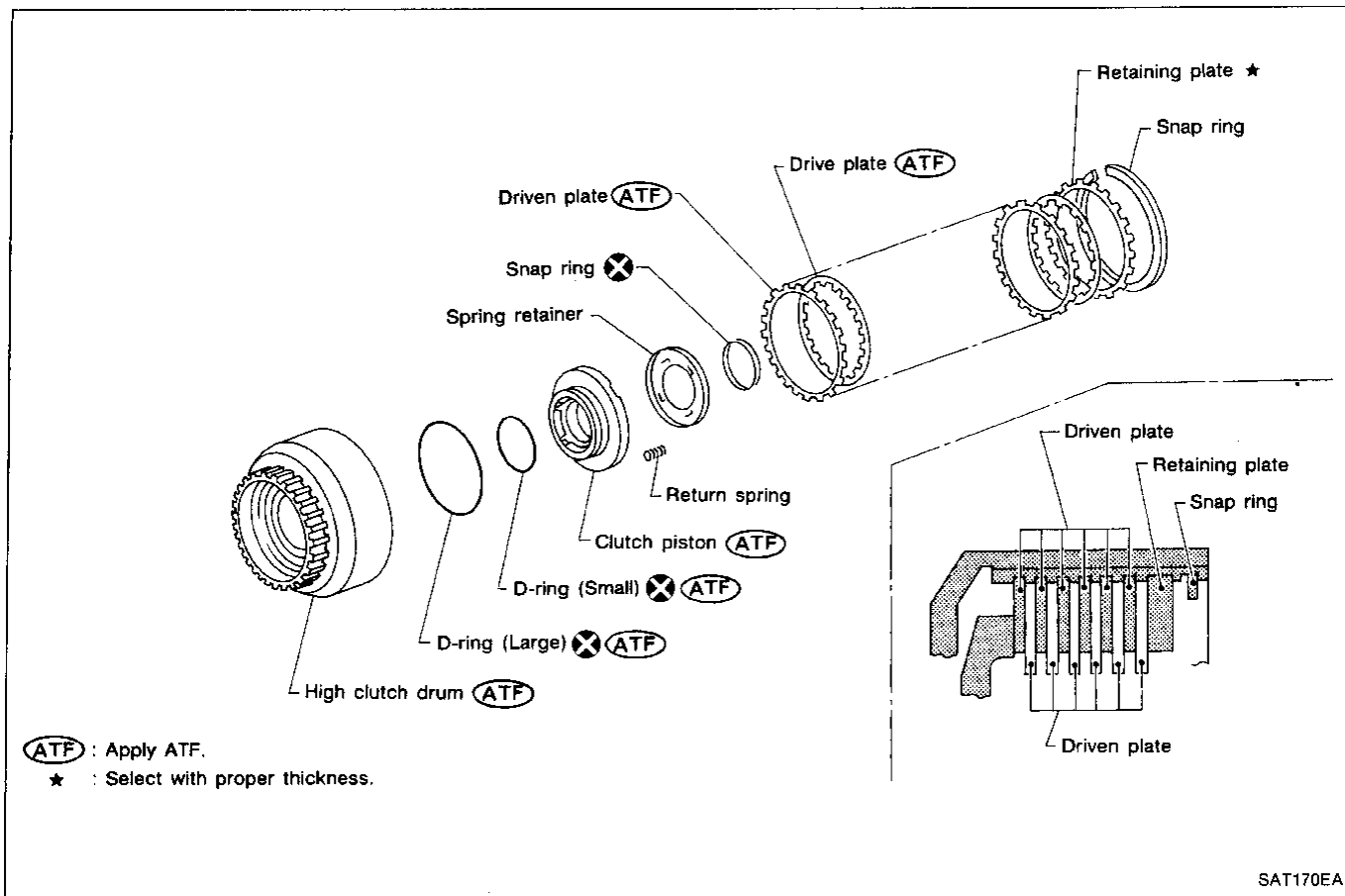

Service procedures for high clutch are essentially the same as those for reverse clutch, with the following exception:

- Check of high clutch operation
- Removal and installation of return spring

# REPAIR FOR COMPONENT PARTS

## High Clutch (Cont'd)

- Inspection of high clutch return springs

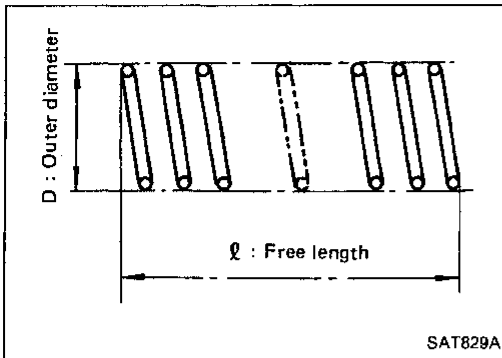

Inspection standard:

Unit: mm (in)

Part No.	l	D
31505-21X03	22.06 (0.8685)	11.6 (0.457)

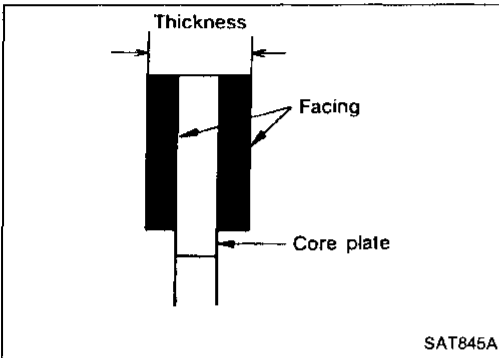

- Inspection of high clutch drive plate

**Thickness of drive plate:**

**Standard**

1.52 - 1.67 mm (0.0598 - 0.0657 in)

**Wear limit**

1.4 mm (0.055 in)

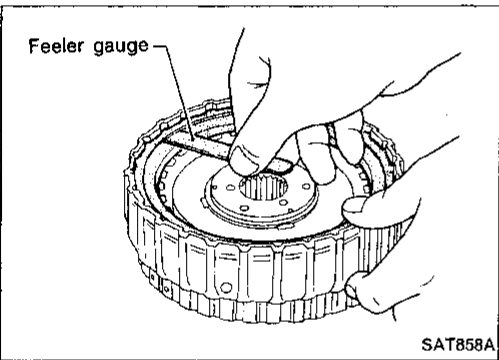

- Measurement of clearance between retaining plate and snap ring

**Specified clearance:**

**Standard**

1.8 - 2.2 mm (0.071 - 0.087 in)

**Allowable limit**

3.4 mm (0.134 in)

**Retaining plate:**

Refer to SDS, AT-191.

GI

MA

EM

LC

EF &  
EC

FE

AT

PD

FA

RA

BR

ST

RS

BT

HA

EL

IDX

# REPAIR FOR COMPONENT PARTS

## Forward and Overrun Clutches

For the number of clutch sheets (drive plate and driven plate), refer to the below cross-section.

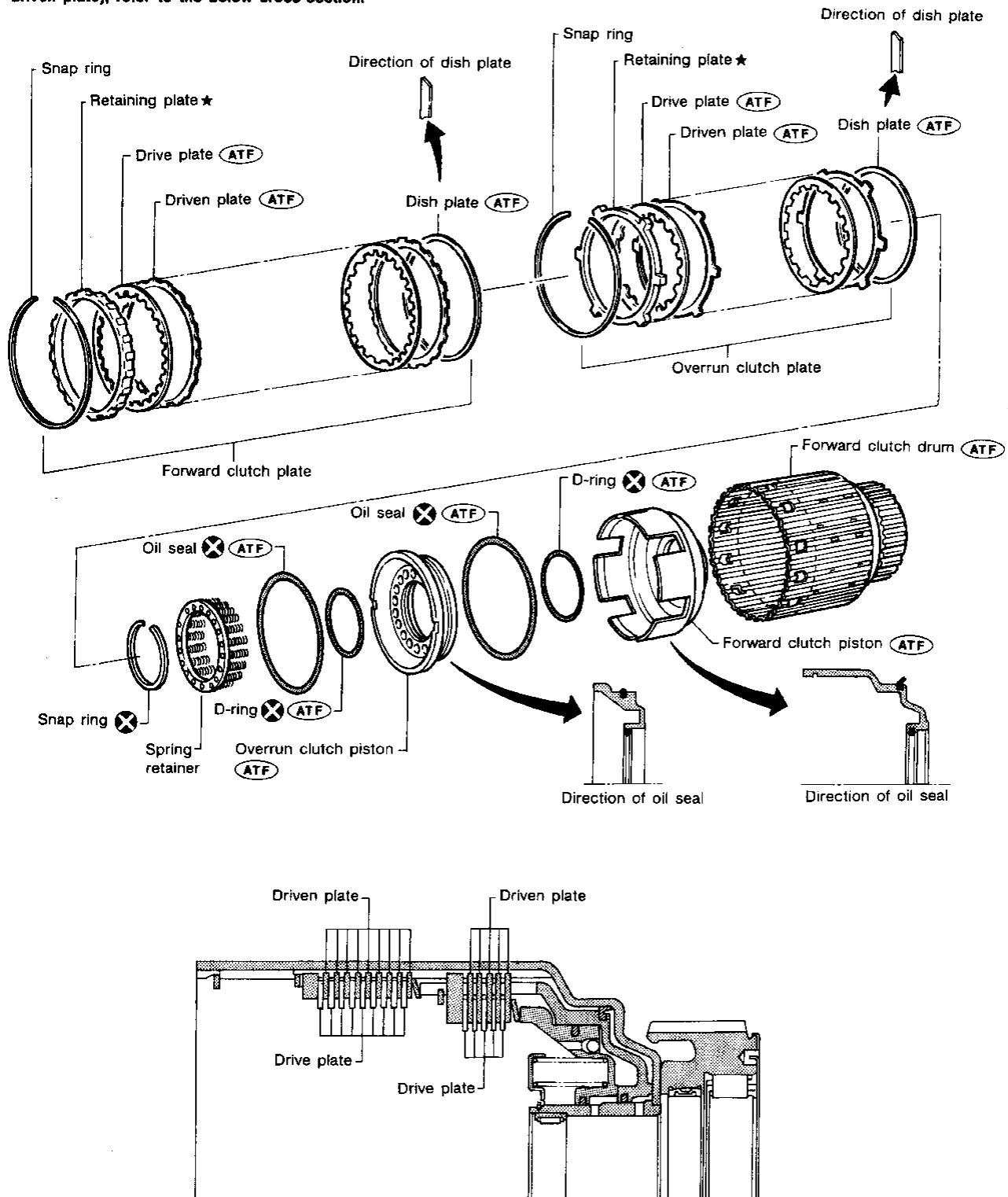

(ATF) : Apply ATF.  
 ★ : Select with proper thickness.



## REPAIR FOR COMPONENT PARTS

### Forward and Overrun Clutches (Cont'd)

Service procedures for forward and overrun clutches are essentially the same as those for reverse clutch, with the following exception:

- Check of forward clutch operation.

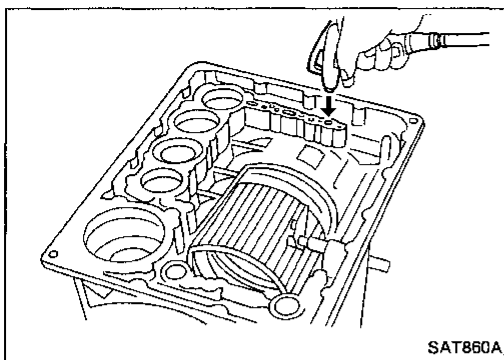

- Check of overrun clutch operation.

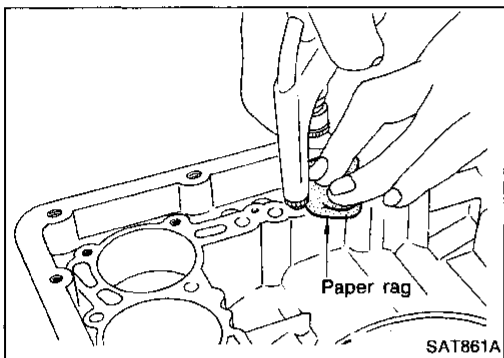

- Removal of forward clutch drum  
Remove forward clutch drum from transmission case by holding snap ring.

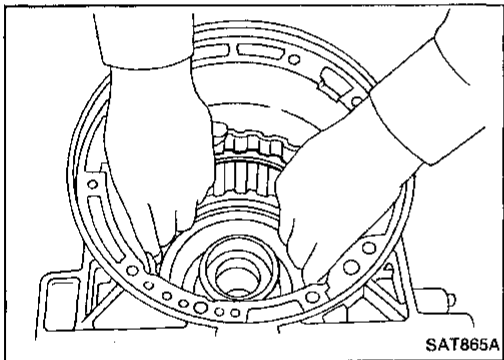

- Removal of forward clutch and overrun clutch pistons  
1. While holding overrun clutch piston, gradually apply compressed air to oil hole.

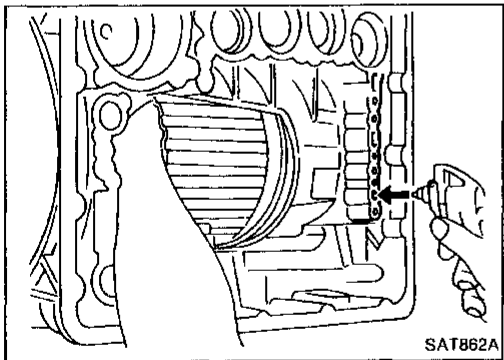

2. Remove overrun clutch from forward clutch.

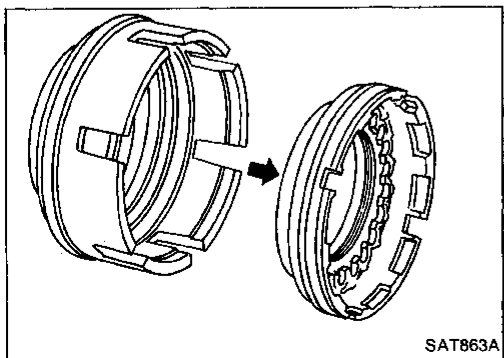

GI

MA

EM

LC

EF &  
EC

FE

AT

PD

FA

RA

BR

ST

RS

BT

HA

EL

IDX

# REPAIR FOR COMPONENT PARTS

## Forward and Overrun Clutches (Cont'd)

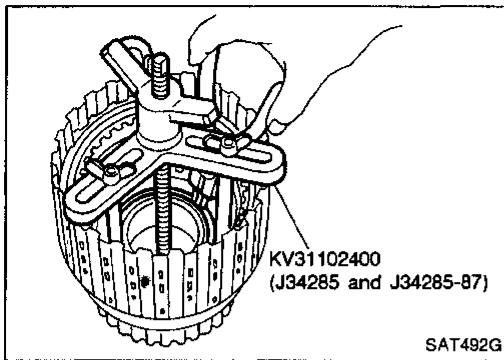

- Removal and installation of return springs

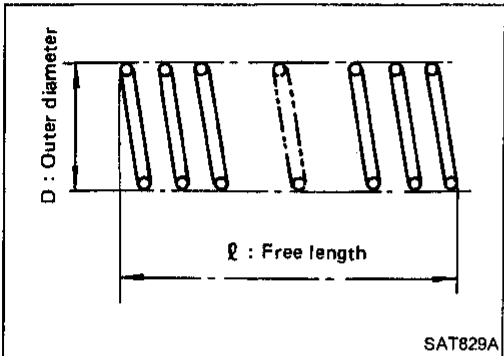

- Inspection of forward clutch and overrun clutch return springs

### Inspection standard:

Unit: mm (in)

Part No.	ℓ	D
31505-51X04	36.8 (1.449)	9.8 (0.386)

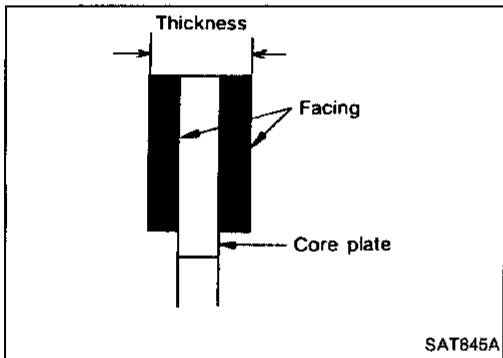

- Inspection of forward clutch drive plates

### Thickness of drive plate:

#### Standard

1.90 - 2.05 mm (0.0748 - 0.0807 in)

#### Wear limit

1.8 mm (0.071 in)

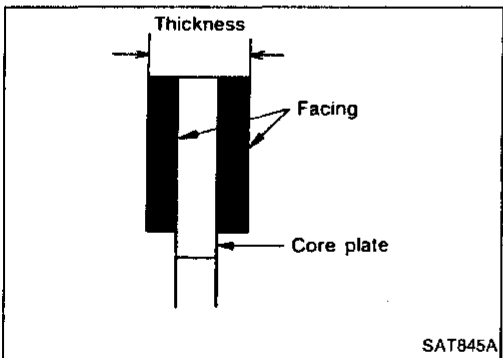

- Inspection of overrun clutch drive plates

### Thickness of drive plate:

#### Standard

1.92 - 2.07 mm (0.0756 - 0.0815 in)

#### Wear limit

1.4 mm (0.055 in)

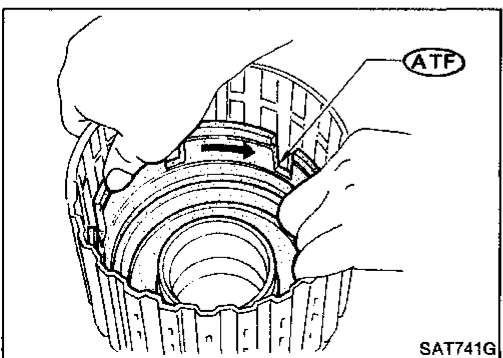

- Installation of forward clutch piston and overrun clutch piston
- 1. Install forward clutch piston by turning it slowly and evenly.
- Apply ATF to inner surface of clutch drum.

## REPAIR FOR COMPONENT PARTS

### Forward and Overrun Clutches (Cont'd)

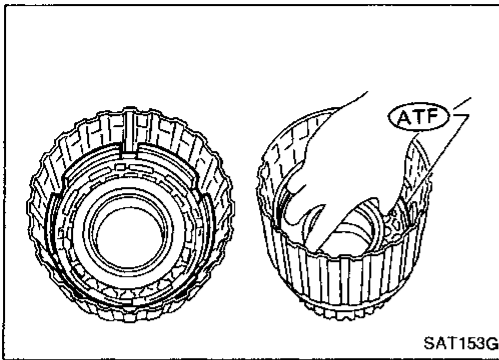

- Align notch in forward clutch piston with groove in forward clutch drum.
- 2. Install overrun clutch by turning it slowly and evenly.
- Apply ATF to inner surface of forward clutch piston.

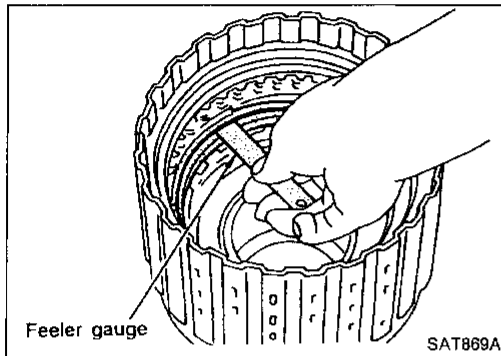

- Measurement of clearance between retaining plate and snap ring of overrun clutch

**Specified clearance:**

**Standard**

1.0 - 1.4 mm (0.039 - 0.055 in)

**Allowable limit**

2.4 mm (0.094 in)

**Retaining plate:**

Refer to SDS, AT-191.

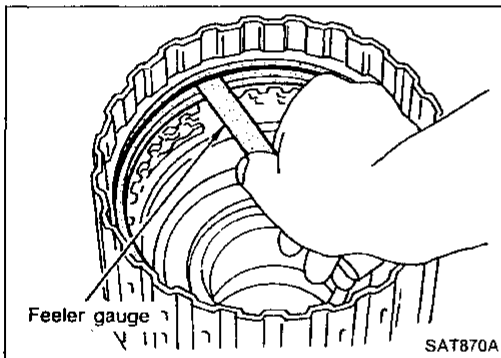

- Measurement of clearance between retaining plate and snap ring of forward clutch

**Specified clearance:**

**Standard**

0.45 - 0.85 mm (0.0177 - 0.0335 in)

**Allowable limit**

2.2 mm (0.087 in)

**Retaining plate:**

Refer to SDS, AT-191.

GI

MA

EM

LC

EF &  
EC

FE

AT

PD

FA

RA

BR

ST

RS

BT

HA

EL

IDX

## Low & Reverse Brake

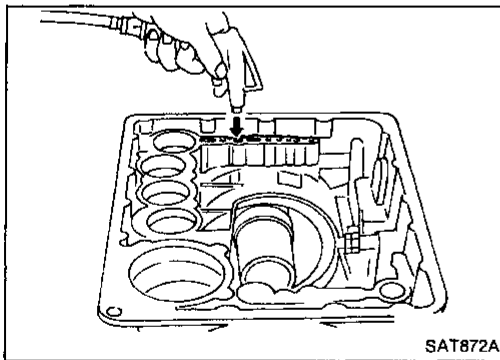
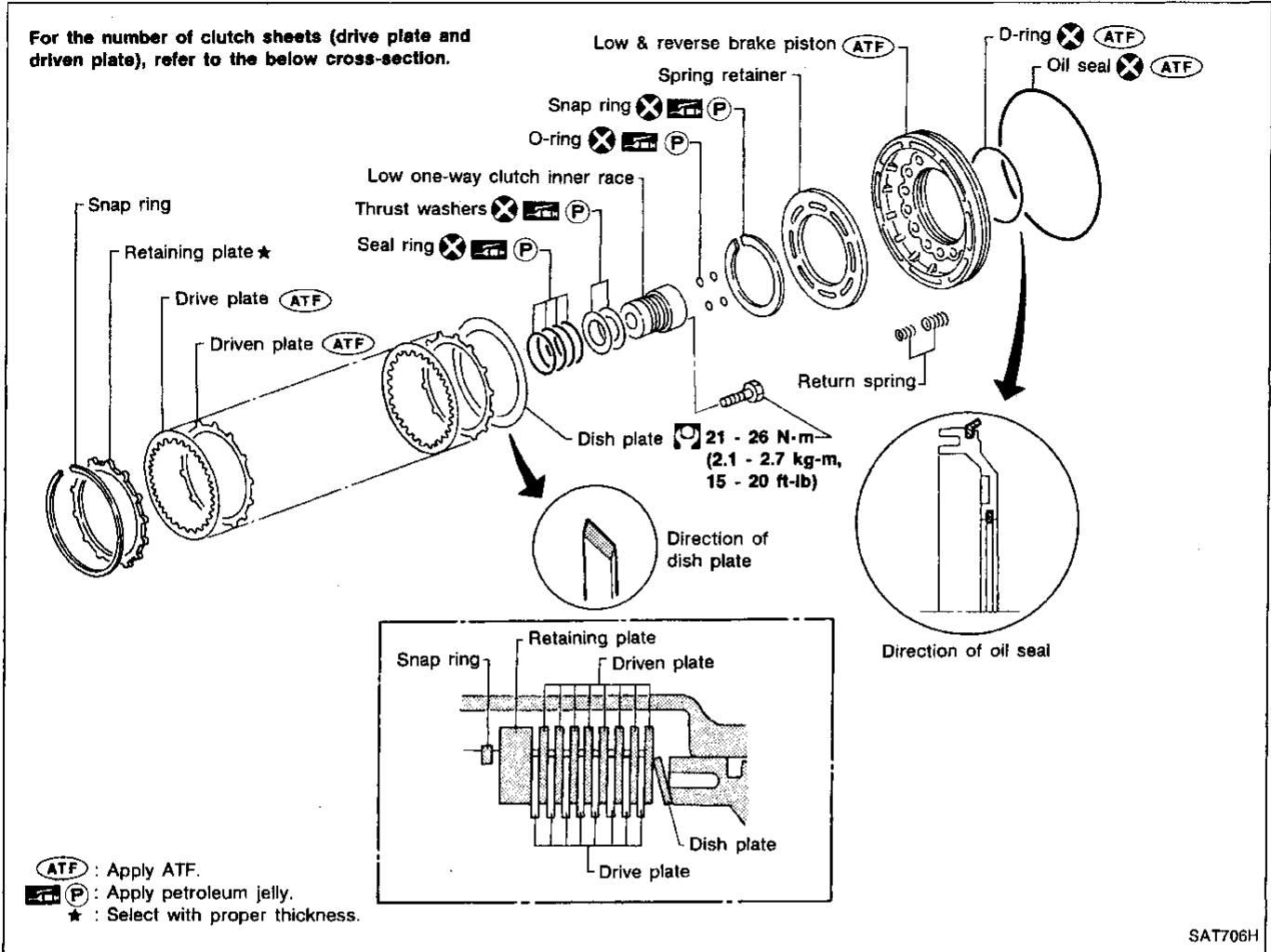

### DISASSEMBLY

1. Check operation of low and reverse brake.
  - a. Install seal ring onto oil pump cover and install reverse clutch. Apply compressed air to oil hole.
  - b. Check to see that retaining plate moves to snap ring.
  - c. If retaining plate does not contact snap ring,
    - D-ring might be damaged.
    - Oil seal might be damaged
    - Fluid might be leaking past piston check ball.

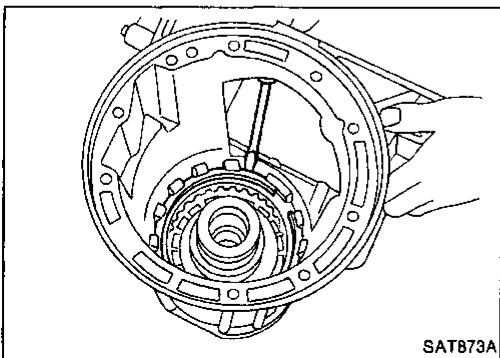

2. Remove snap ring, low and reverse brake drive plates, driven plates and dish plate.

## REPAIR FOR COMPONENT PARTS

### Low & Reverse Brake (Cont'd)

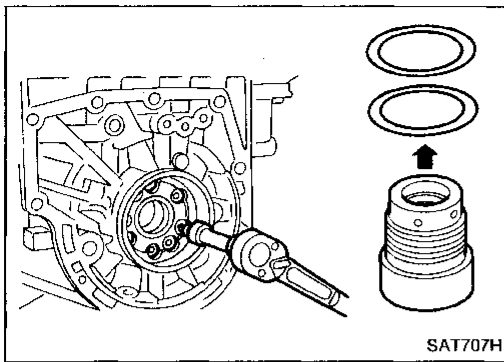

3. Remove low one-way clutch inner race, spring retainer and return spring from transmission case.
4. Remove seal rings from low one-way clutch inner race.
5. Remove thrust washers from low one-way clutch inner race.

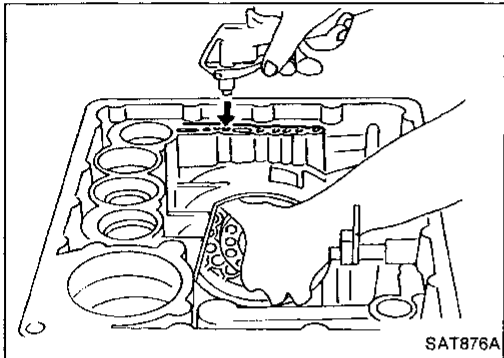

6. Remove low and reverse brake piston using compressed air.
7. Remove oil seal and D-ring from piston.

### INSPECTION

#### Low and reverse brake snap ring and spring retainer

- Check for deformation, or damage.

#### Low and reverse brake return springs

- Check for deformation or damage. Also measure free length and outside diameter.

#### Inspection standard:

Unit: mm (in)

	Part No.	ℓ	D
Inner spring	31505-51X06	20.43 (0.8043)	10.3 (0.406)
Outer spring	31505-51X05	20.35 (0.8012)	13.0 (0.512)

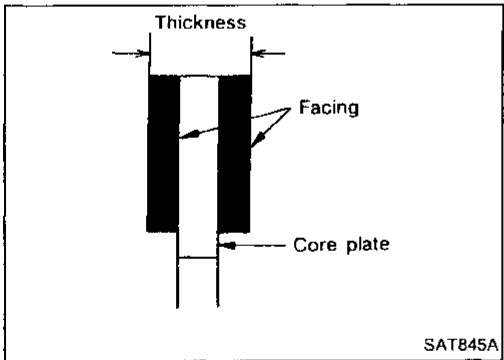
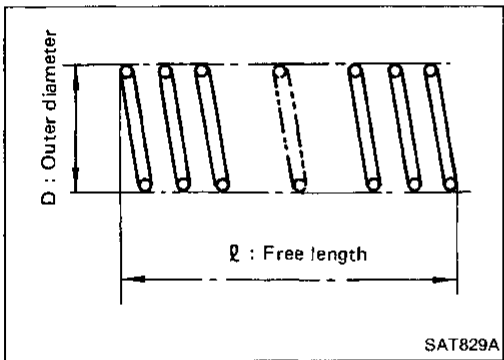

#### Low and reverse brake drive plates

- Check facing for burns, cracks or damage.
- Measure thickness of facing.

#### Thickness of drive plate:

##### Standard value

1.52 - 1.67 mm (0.0598 - 0.0657 in)

##### Wear limit

1.4 mm (0.055 in)

- If not within wear limit, replace.

GI

MA

EM

LC

EF &  
EC

FE

AT

PD

FA

RA

BR

ST

RS

BT

HA

EL

IDX

## REPAIR FOR COMPONENT PARTS

### Low & Reverse Brake (Cont'd)

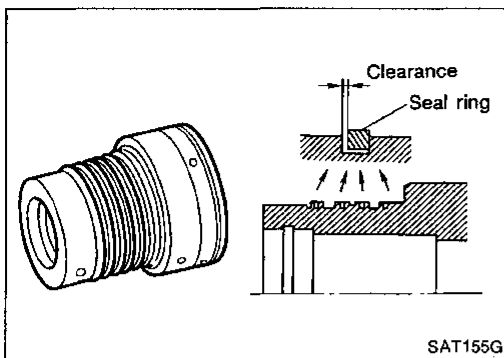

#### Low one-way clutch inner race

- Check frictional surface of inner race for wear or damage.
- Install new seal rings onto low one-way clutch inner race.
- **Be careful not to expand seal ring gap excessively.**
- Measure seal ring-to-groove clearance.

#### Inspection standard:

##### Standard value

0.10 - 0.25 mm (0.0039 - 0.0098 in)

##### Allowable limit

0.25 mm (0.0098 in)

- If not within allowable limit, replace low one-way clutch inner race.

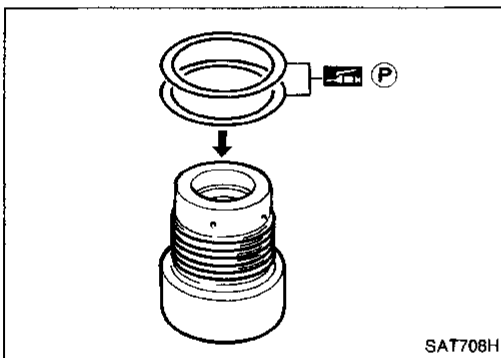

### ASSEMBLY

1. Install thrust washers onto one-way clutch inner race.

- Pay attention to its direction — **Black surface goes to rear side.**
- Apply petroleum jelly to thrust washers.

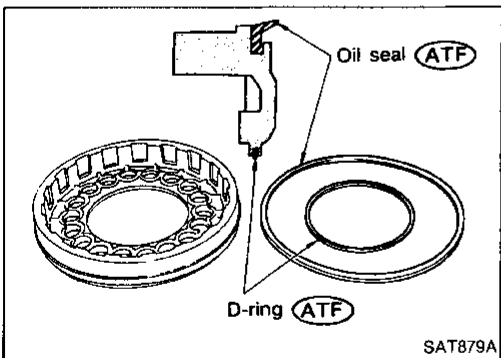

2. Install oil seal and D-ring onto piston.

- Apply ATF to oil seal and D-ring.

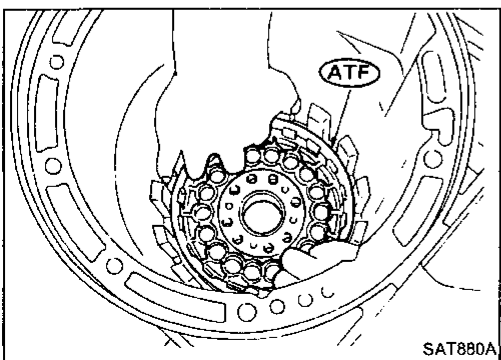

3. Install piston by rotating it slowly and evenly.

- Apply ATF to inner surface of transmission case.

## REPAIR FOR COMPONENT PARTS

### Low & Reverse Brake (Cont'd)

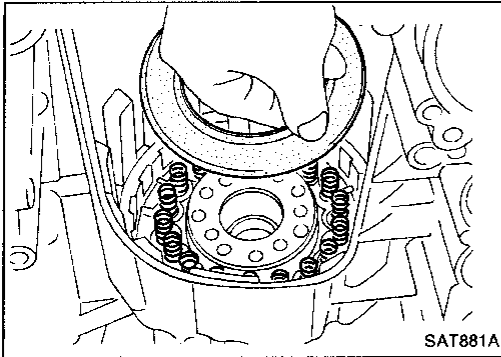

4. Install return springs, spring retainer and low one-way clutch inner race onto transmission case.

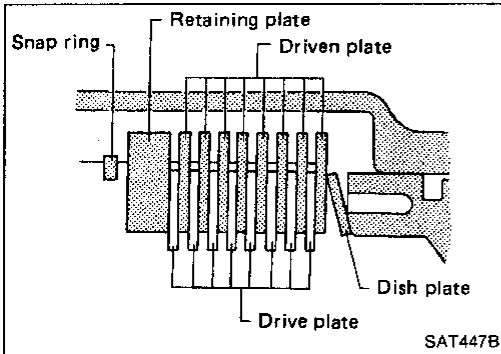

5. Install dish plate, low and reverse brake drive plates, driven plates and retaining plate.
6. Install snap ring on transmission case.

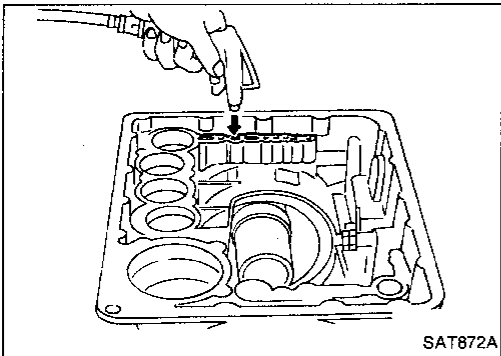

7. Check operation of low and reverse brake clutch piston. Refer to "DISASSEMBLY", AT-156.

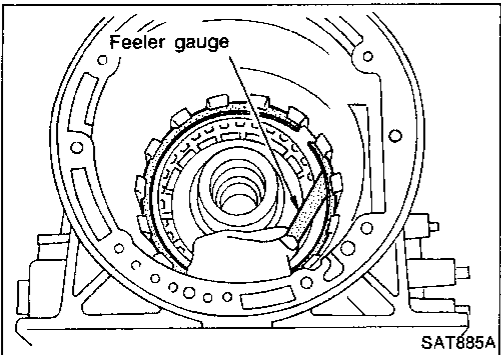

8. Measure clearance between retaining plate and snap ring. If not within allowable limit, select proper retaining plate.

**Specified clearance:**

**Standard**

0.90 - 1.20 mm (0.0354 - 0.0472 in)

**Allowable limit**

2.4 mm (0.094 in)

**Retaining plate:**

Refer to SDS, AT-192.

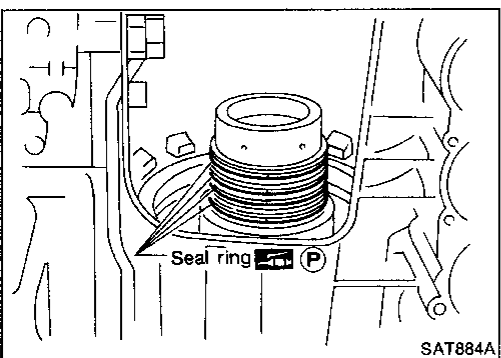

9. Install low one-way clutch inner race seal ring.
  - Apply petroleum jelly to seal ring.
  - Make sure seal rings are pressed firmly into place and held by petroleum jelly.

GI

MA

EM

LC

EF &  
EC

FE

AT

PD

FA

RA

BR

ST

RS

BT

HA

EL

IDX

Forward Clutch Drum Assembly

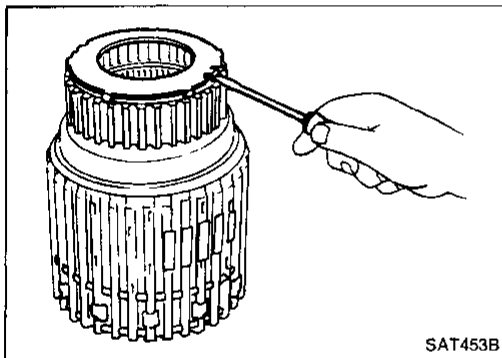
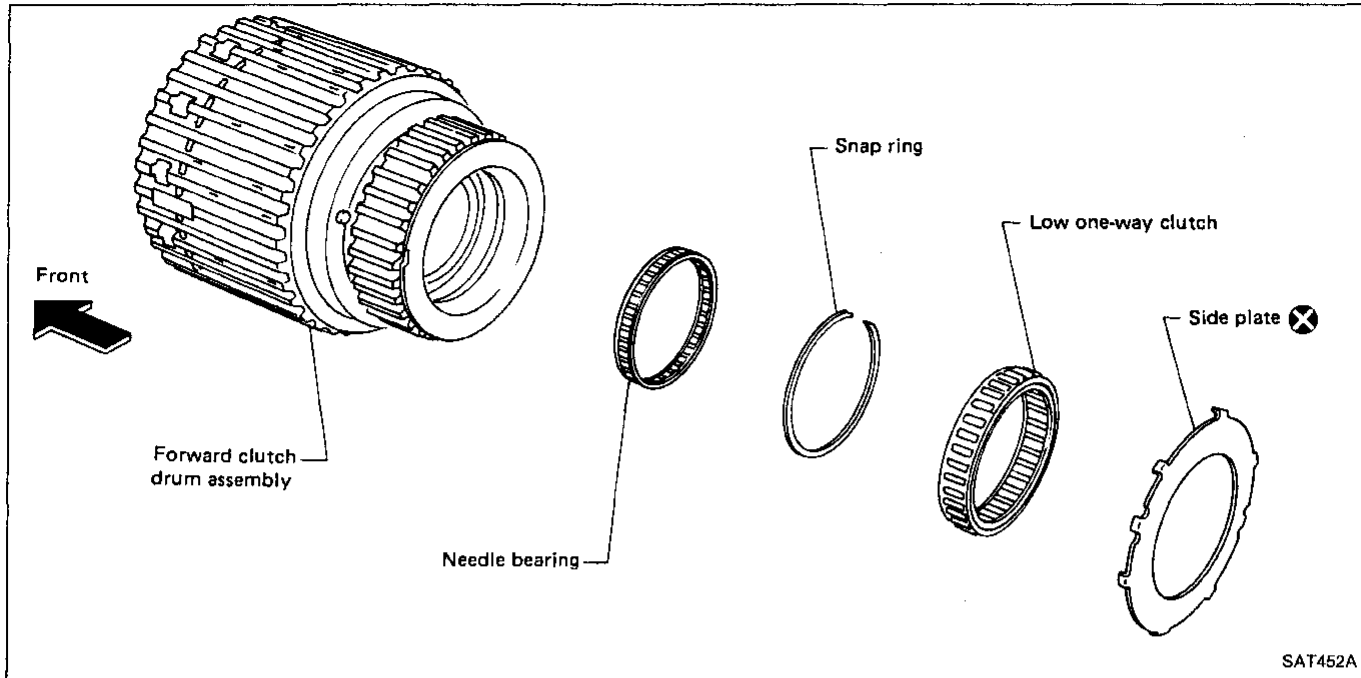

**DISASSEMBLY**

1. Remove side plate from forward clutch drum.
2. Remove low one-way clutch from forward clutch drum.
3. Remove snap ring from forward clutch drum.
4. Remove needle bearing from forward clutch drum.

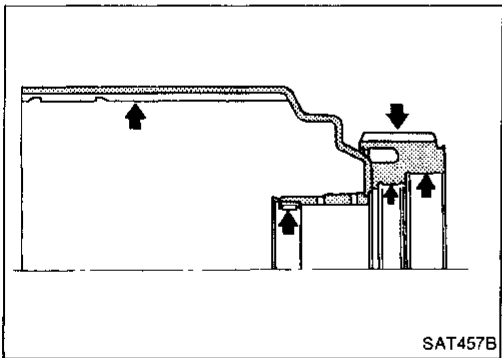

**INSPECTION**

**Forward clutch drum**

- Check spline portion for wear or damage.
- Check frictional surfaces of low one-way clutch and needle bearing for wear or damage.

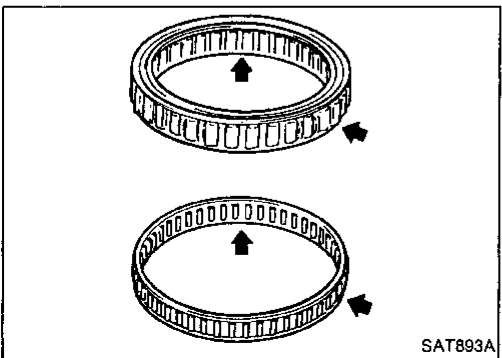

**Needle bearing and low one-way clutch**

- Check frictional surface for wear or damage.



# REPAIR FOR COMPONENT PARTS

## Forward Clutch Drum Assembly (Cont'd)

### ASSEMBLY

1. Install needle bearing in forward clutch drum.
2. Install snap ring onto forward clutch drum.

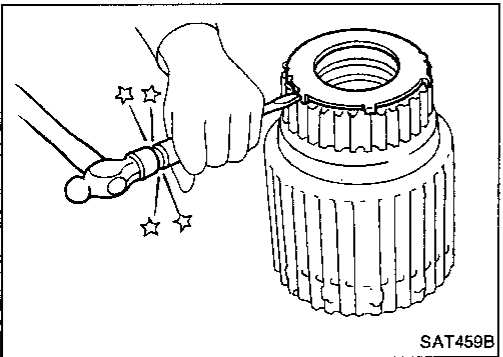
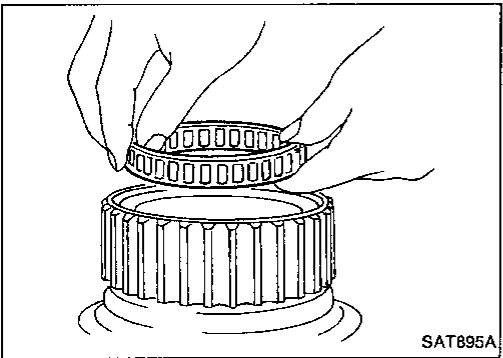
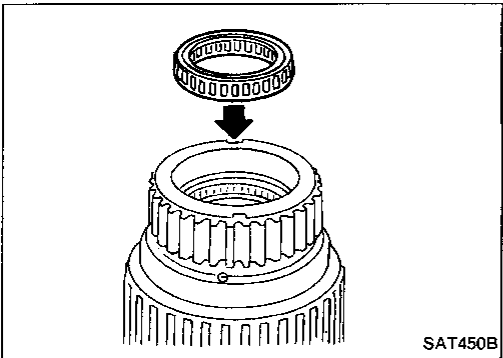
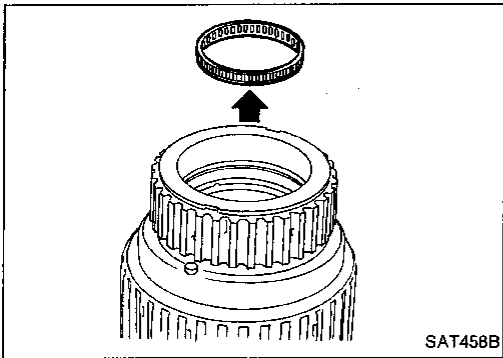

3. Install low one-way clutch onto forward clutch drum by pushing the roller in evenly.

- Install low one-way clutch with flange facing rearward.

4. Install side plate onto forward clutch drum.

GI

MA

EM

LC

EF &  
EC

FE

AT

PD

FA

RA

BR

ST

RS

BT

HA

EL

IDX

## Rear Internal Gear and Forward Clutch Hub

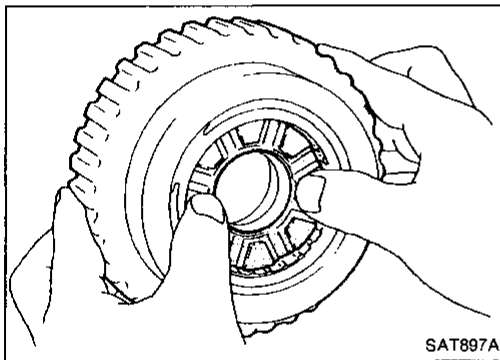
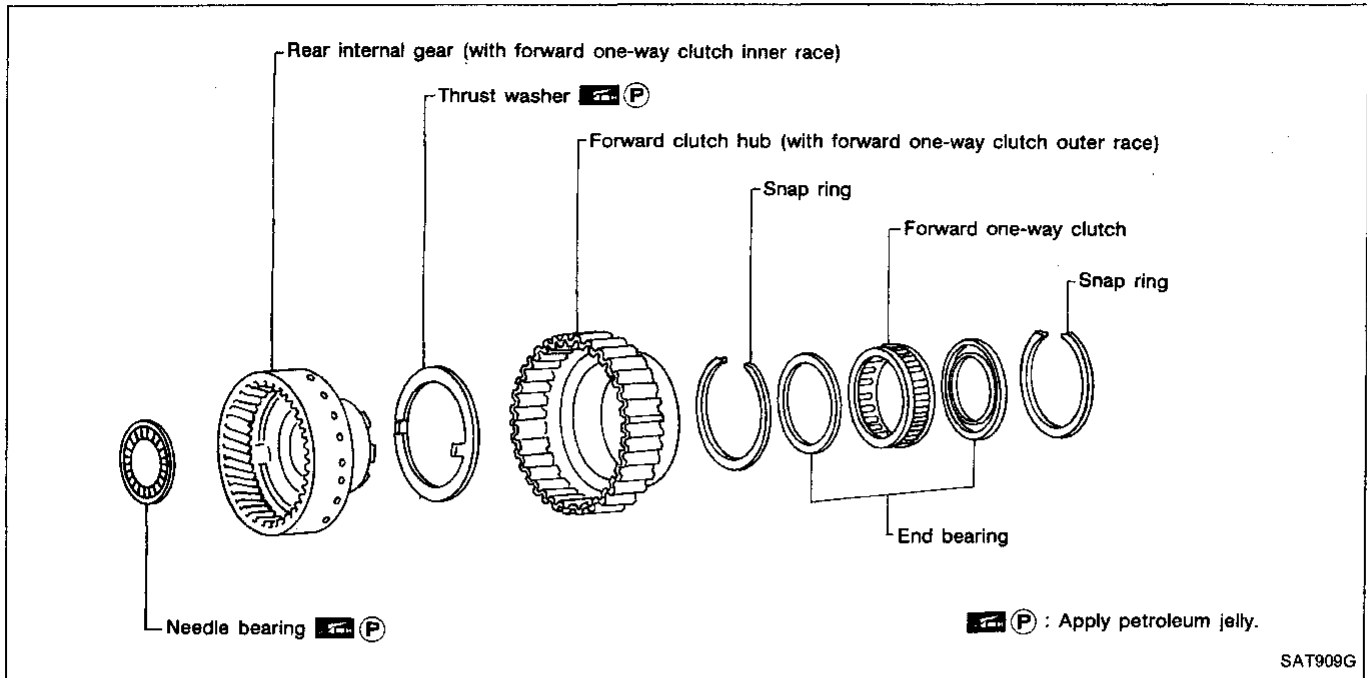

### DISASSEMBLY

1. Remove needle bearing from rear internal gear.
2. Remove rear internal gear by pushing forward clutch hub forward.
3. Remove thrust washer from rear internal gear.
4. Remove snap ring from forward clutch hub.
5. Remove end bearing.
6. Remove forward one-way clutch and end bearing as a unit from forward clutch hub.
7. Remove snap ring from forward clutch hub.

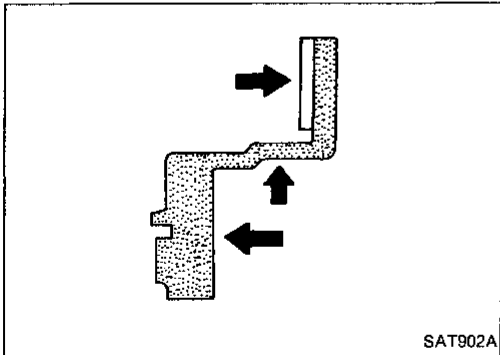

### INSPECTION

#### Rear internal gear and forward clutch hub

- Check gear for excessive wear, chips or cracks.
- Check frictional surfaces of forward one-way clutch and thrust washer for wear or damage.
- Check spline for wear or damage.

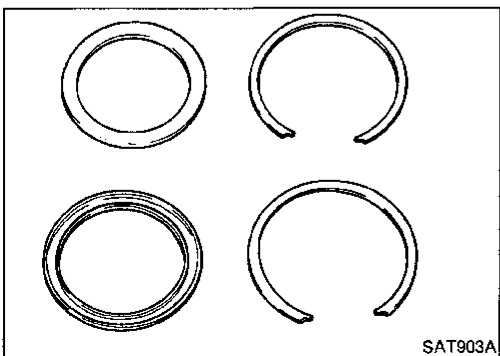

#### Snap ring and end bearing

- Check for deformation or damage.

## REPAIR FOR COMPONENT PARTS

### Rear Internal Gear and Forward Clutch Hub (Cont'd)

#### ASSEMBLY

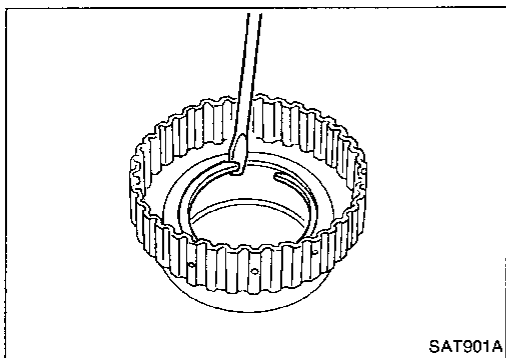

1. Install snap ring onto forward clutch hub.
2. Install end bearing.

GI

MA

EM

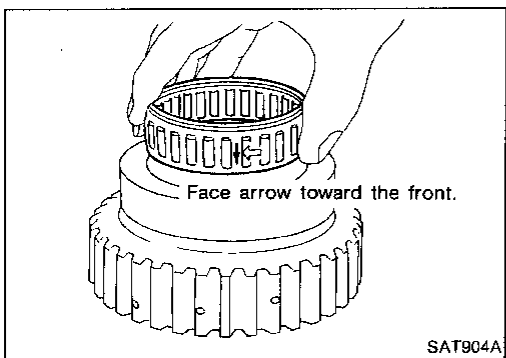

3. Install forward one-way clutch onto clutch hub.
  - **Install forward one-way clutch with flange facing rearward.**
4. Install end bearing.
5. Install snap ring onto forward clutch hub.

LC

EF &  
EC

FE

AT

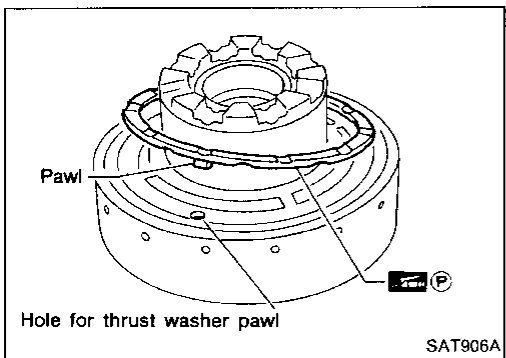

6. Install thrust washer onto rear internal gear.
  - **Apply petroleum jelly to thrust washer.**
  - **Securely insert pawls of thrust washer into holes in rear internal gear.**

PD

FA

RA

BR

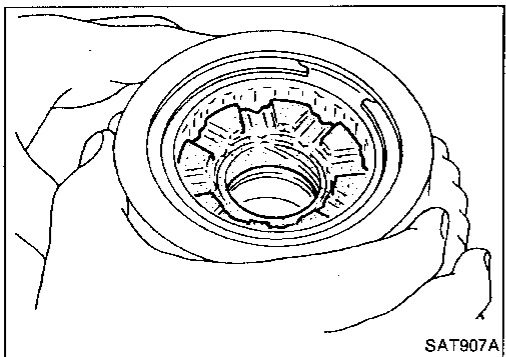

7. Position forward clutch hub in rear internal gear.

ST

RS

BT

HA

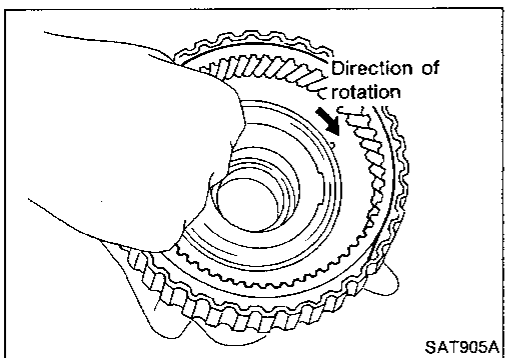

8. After installing, check to assure that forward clutch hub rotates clockwise.

EL

IDX

**Band Servo Piston Assembly**

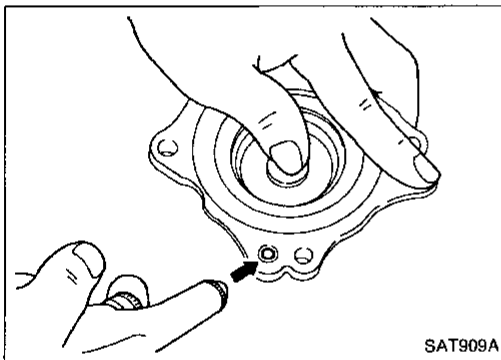
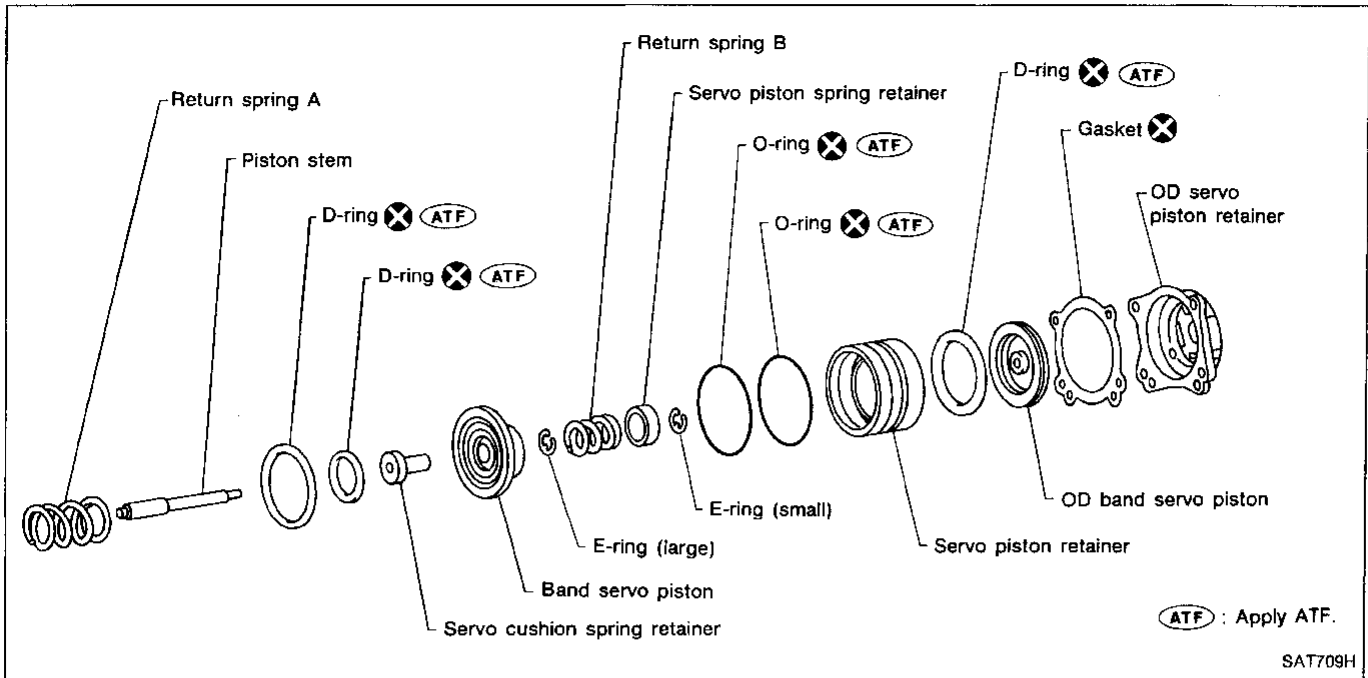

**DISASSEMBLY**

1. Block one oil hole in OD servo piston retainer and the center hole in OD band servo piston.
2. Apply compressed air to the other oil hole in piston retainer to remove OD band servo piston from retainer.
3. Remove D-ring from OD band servo piston.

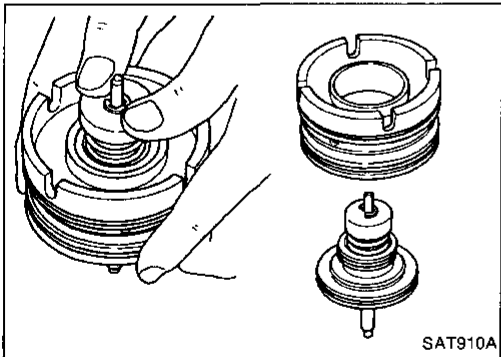

4. Remove band servo piston assembly from servo piston retainer by pushing it forward.

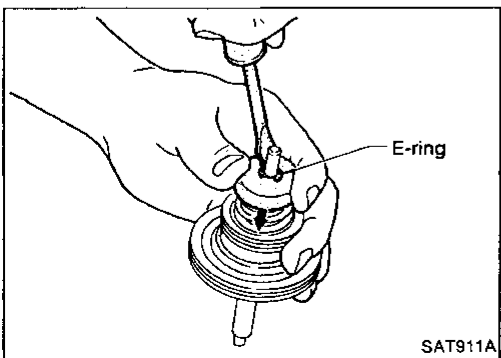

5. Place piston stem end on a wooden block. While pushing servo piston spring retainer down, remove E-ring.

# REPAIR FOR COMPONENT PARTS

## Band Servo Piston Assembly (Cont'd)

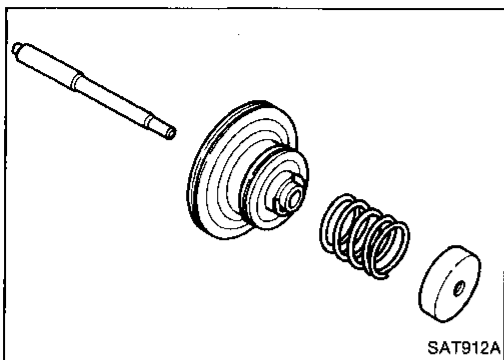

6. Remove servo piston spring retainer, return spring B and piston stem from band servo piston.
7. Remove E-ring from band servo piston.

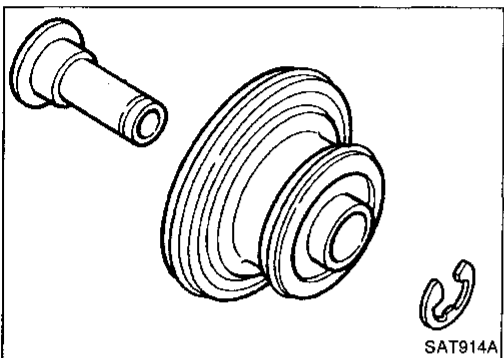

8. Remove servo cushion spring retainer from band servo piston.
9. Remove D-rings from band servo piston.
10. Remove O-rings from servo piston retainer.

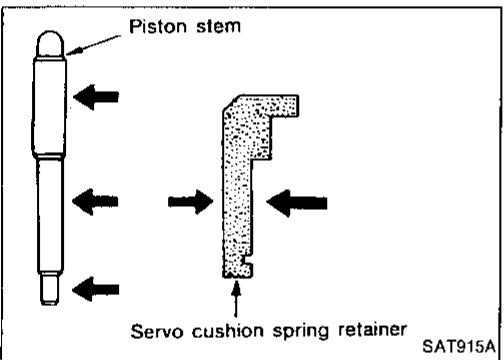

### INSPECTION

#### Pistons, retainers and piston stem

- Check frictional surfaces for abnormal wear or damage.

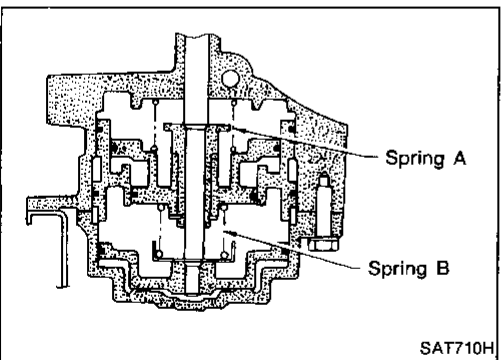

#### Return springs

- Check for deformation or damage. Measure free length and outer diameter.

#### Inspection standard:

Unit: mm (in)

Parts	Free length	Outer diameter
Spring A	52.0 (2.047)	38.7 (1.524)
Spring B	29.0 (1.142)	27.6 (1.087)

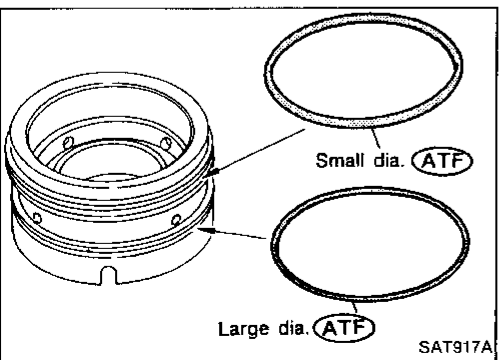

### ASSEMBLY

1. Install O-rings onto servo piston retainer.
- Apply ATF to O-rings.
  - Pay attention to position of each O-ring.

## REPAIR FOR COMPONENT PARTS

### Band Servo Piston Assembly (Cont'd)

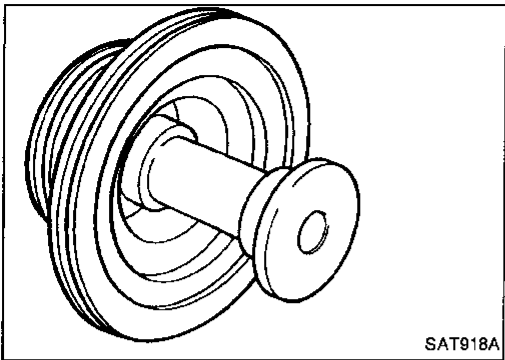

2. Install servo cushion spring retainer onto band servo piston.
3. Install E-ring onto servo cushion spring retainer.

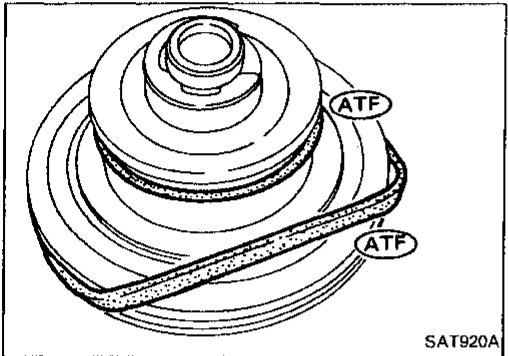

4. Install D-rings onto band servo piston.
  - **Apply ATF to D-rings.**

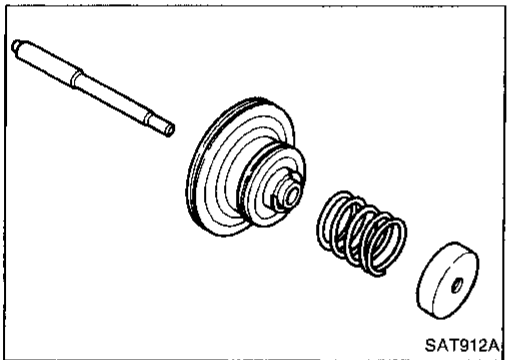

5. Install servo piston spring retainer, return spring B and piston stem onto band servo piston.

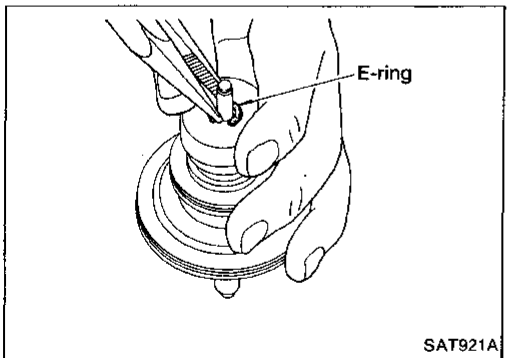

6. Place piston stem end on a wooden block. While pushing servo piston spring retainer down, install E-ring.

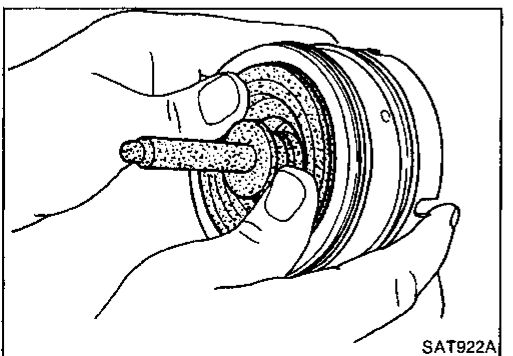

7. Install band servo piston assembly onto servo piston retainer by pushing it inward.

## REPAIR FOR COMPONENT PARTS

### Band Servo Piston Assembly (Cont'd)

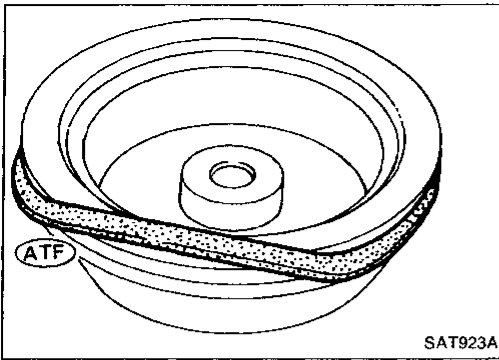

8. Install D-ring on OD band servo piston.
  - Apply ATF to D-ring.

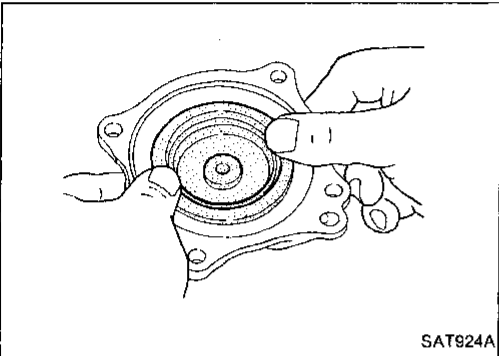

9. Install OD band servo piston onto servo piston retainer by pushing it inward.

GI

MA

EM

LC

EF &  
EC

FE

AT

PD

FA

RA

BR

ST

RS

BT

HA

EL

IDX

Parking Pawl Components

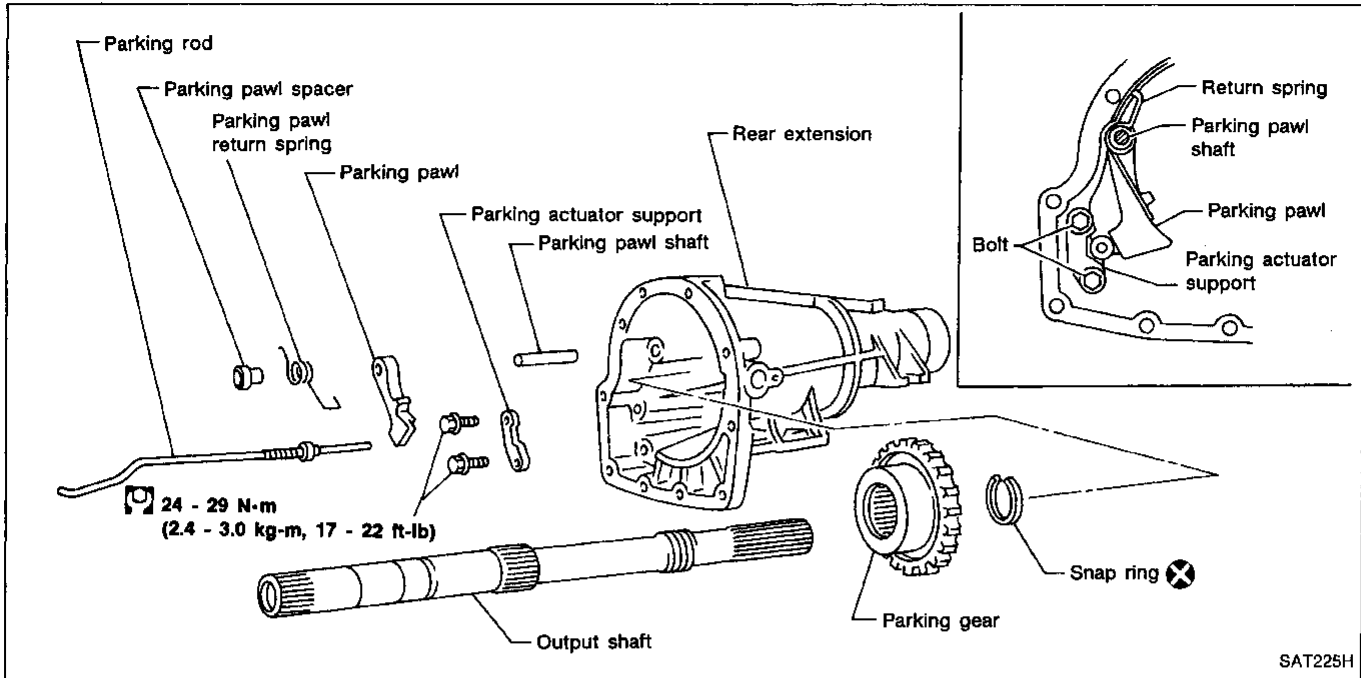

SAT225H

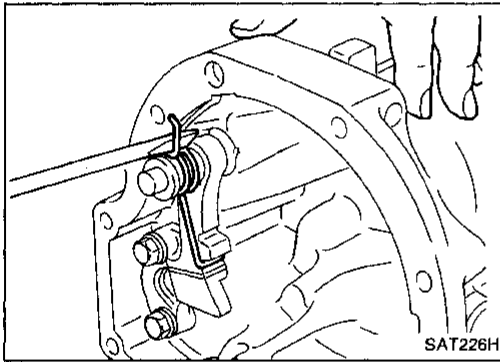

SAT226H

DISASSEMBLY

1. Slide return spring to the front of rear extension flange.

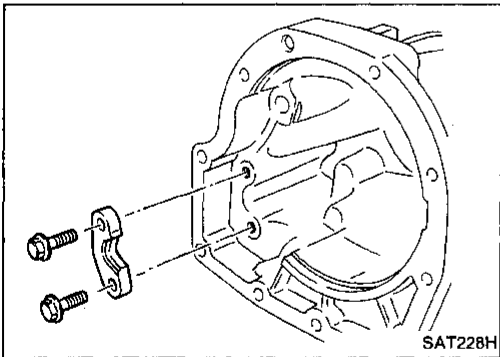

SAT228H

2. Remove return spring, pawl spacer and parking pawl from rear extension.
3. Remove parking pawl shaft from rear extension.
4. Remove parking actuator support from rear extension.

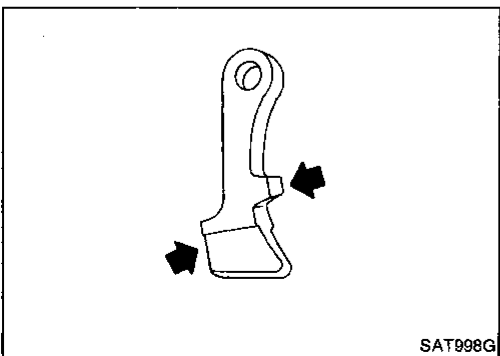

SAT998G

INSPECTION

Parking pawl and parking actuator support

- Check contact surface of parking rod for wear.



## REPAIR FOR COMPONENT PARTS

### Parking Pawl Components (Cont'd)

#### ASSEMBLY

1. Install parking actuator support onto rear extension.
2. Insert parking pawl shaft into rear extension.
3. Install return spring, pawl spacer and parking pawl onto parking pawl shaft.

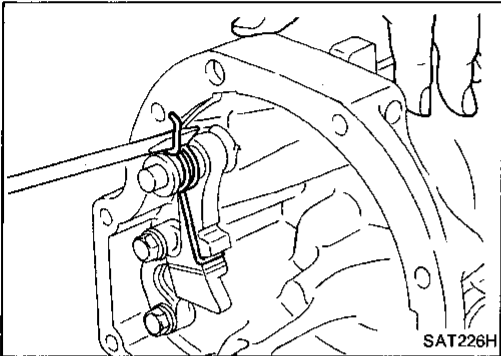
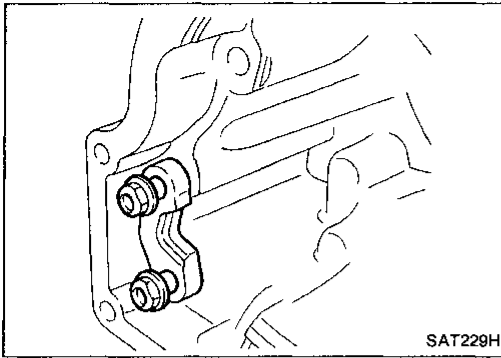

4. Bend return spring upward and install it onto rear extension.

GI

MA

EM

LC

EF &  
EC

FE

**AT**

PD

FA

RA

BR

ST

RS

BT

HA

EL

IDX

## ASSEMBLY

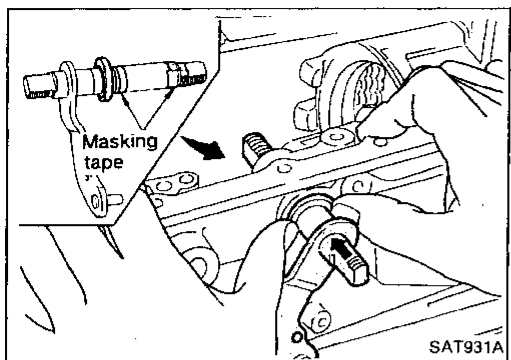

### Assembly (1)

1. Install manual shaft components.
  - a. Install oil seal onto manual shaft.
    - **Apply ATF to oil seal.**
    - **Wrap threads of manual shaft with masking tape.**
  - b. Insert manual shaft and oil seal as a unit into transmission case.
  - c. Remove masking tape.

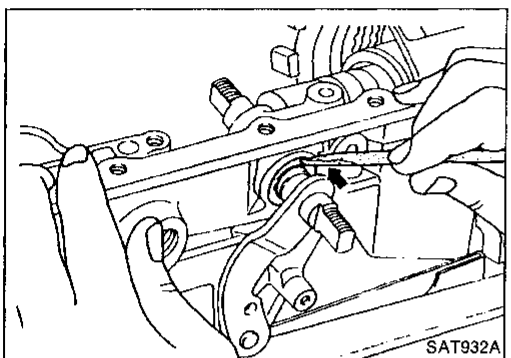

- d. Push oil seal evenly and install it onto transmission case.

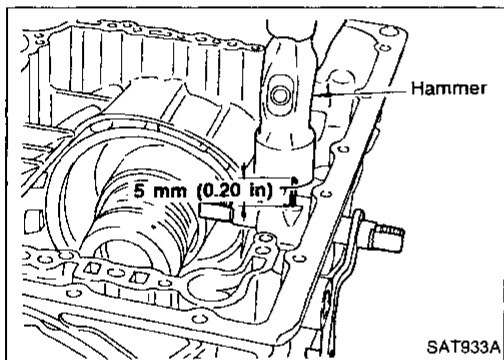

- e. Align groove in shaft with drive pin hole, then drive pin into position as shown in figure at left.

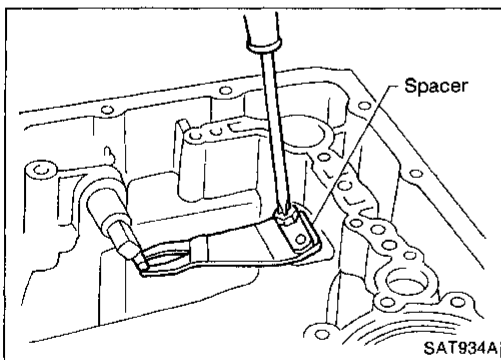

- f. Install detent spring and spacer.

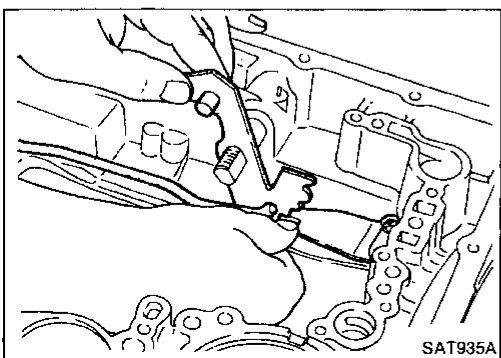

- g. While pushing detent spring down, install manual plate onto manual shaft.

# ASSEMBLY

## Assembly (1) (Cont'd)

h. Install lock nuts onto manual shaft.

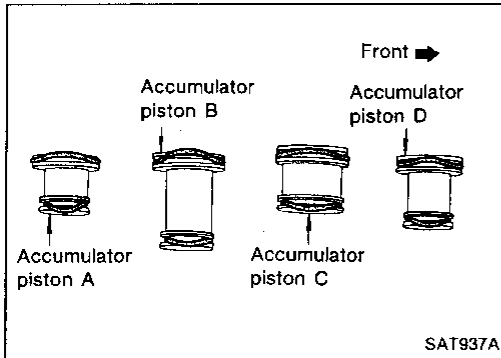
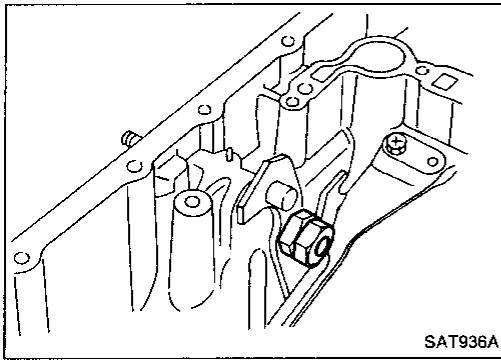

2. Install accumulator piston.

a. Install O-rings onto accumulator piston.

● Apply ATF to O-rings.

### Accumulator piston O-rings

Unit: mm (in)

Accumulator	A	B	C	D
Small diameter end	29 (1.14)	32 (1.26)	45 (1.77)	29 (1.14)
Large diameter end	45 (1.77)	50 (1.97)	50 (1.97)	45 (1.77)

b. Install return spring for accumulator A onto transmission case.

### Free length of return spring

Unit: mm (in)

Accumulator	A
Free length	43.0 (1.693)

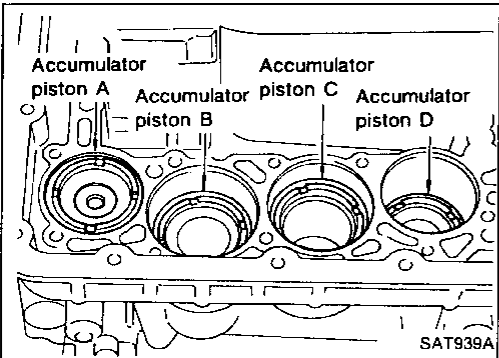
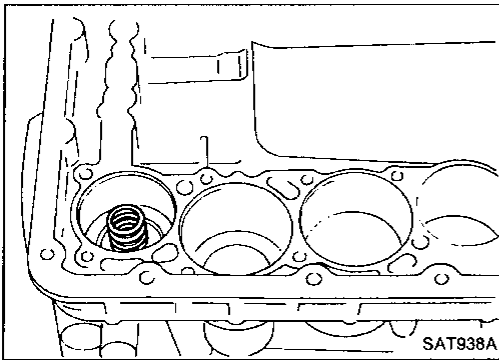

c. Install accumulator pistons A, B, C and D.

● Apply ATF to transmission case.

3. Install band servo piston.

a. Install return spring onto servo piston.

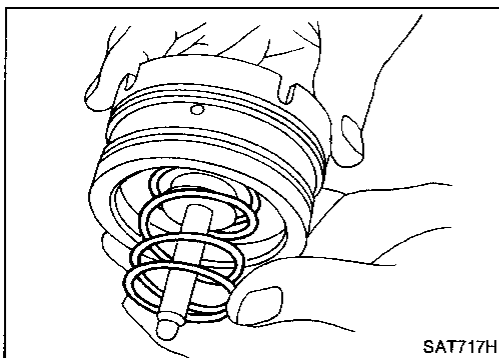

## ASSEMBLY

### Assembly (1) (Cont'd)

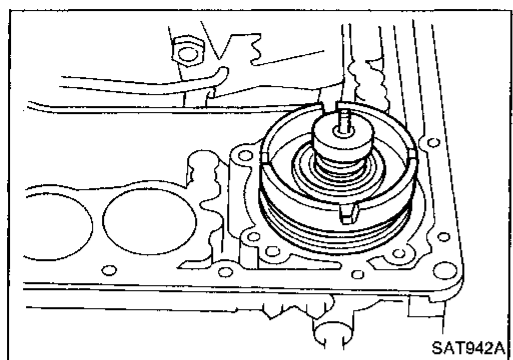

- b. Install band servo piston onto transmission case.
  - Apply ATF to O-ring of band servo piston and transmission case.
- c. Install gasket for band servo onto transmission case.

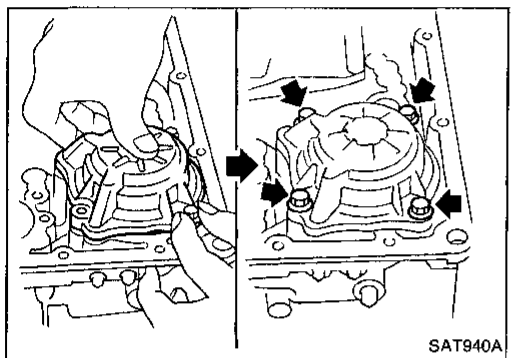

- d. Install band servo retainer onto transmission case.

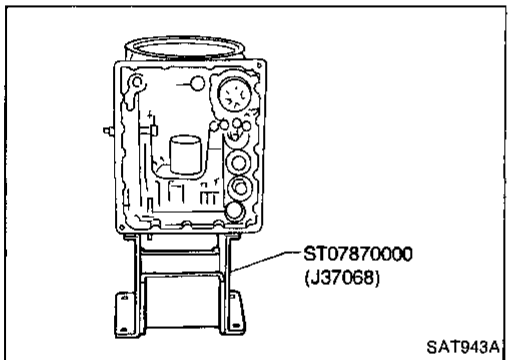

4. Install rear side clutch and gear components.
  - a. Place transmission case in vertical position.

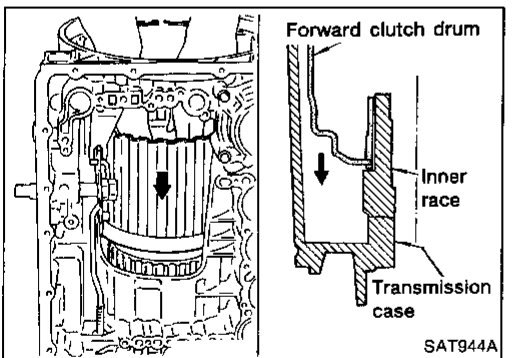

- b. Slightly lift forward clutch drum assembly and slowly rotate it clockwise until its hub passes fully over the clutch inner race inside transmission case.

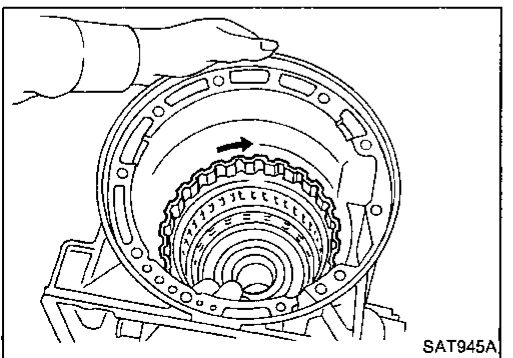

- c. Check to be sure that rotation direction of forward clutch assembly is correct.

## ASSEMBLY

### Assembly (1) (Cont'd)

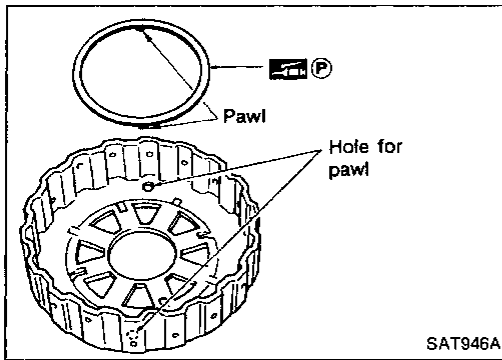

- d. Install thrust washer onto front of overrun clutch hub.
- Apply petroleum jelly to the thrust washer.
  - Insert pawls of thrust washer securely into holes in overrun clutch hub.

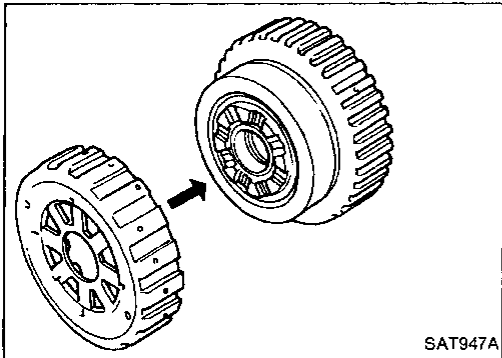

- e. Install overrun clutch hub onto rear internal gear assembly.

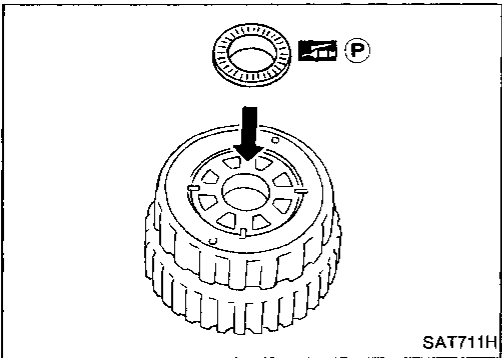

- f. Install needle bearing onto rear of overrun clutch hub.
- Apply petroleum jelly to needle bearing.

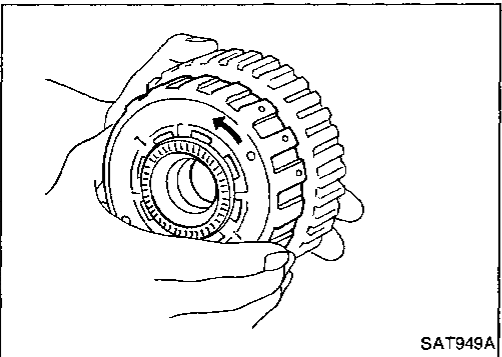

- g. Check that overrun clutch hub rotates as shown while holding forward clutch hub.
- h. Place transmission case into horizontal position.

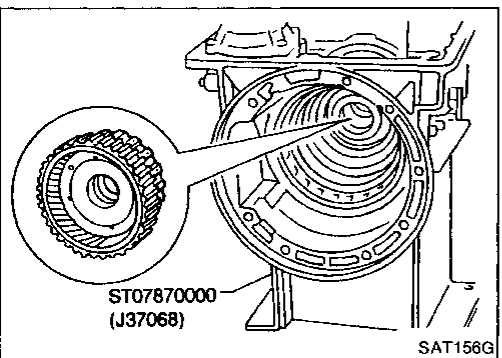

- i. Install rear internal gear, forward clutch hub and overrun clutch hub as a unit onto transmission case.
- j. Install needle bearing onto rear internal gear.
- Apply petroleum jelly to needle bearing.

GI

MA

EM

LC

EF &  
EC

FE

AT

PD

FA

RA

BR

ST

RS

BT

HA

EL

IDX

## ASSEMBLY

### Assembly (1) (Cont'd)

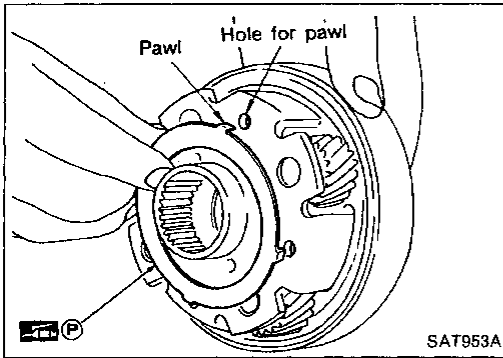

- k. Install bearing race onto rear of front internal gear.
  - Apply petroleum jelly to bearing race.
  - Securely engage pawls of bearing race with holes in front internal gear.

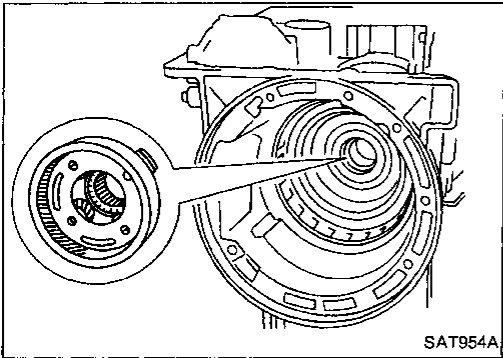

- l. Install front internal gear on transmission case.

# ASSEMBLY

## Adjustment

When any parts listed below are replaced, adjust total end play and reverse clutch end play.

Part name	Item	
	Total end play	Reverse clutch end play
Transmission case	•	•
Low one-way clutch inner race	•	•
Overrun clutch hub	•	•
Rear internal gear	•	•
Rear planetary carrier	•	•
Rear sun gear	•	•
Front planetary carrier	•	•
Front sun gear	•	•
High clutch hub	•	•
High clutch drum	•	•
Oil pump cover	•	•
Reverse clutch drum	—	•

GI  
MA  
EM  
LC  
EF & EC  
FE  
AT  
PD

FA  
RA  
BR

ST  
RS  
BT  
HA

EL  
IDX

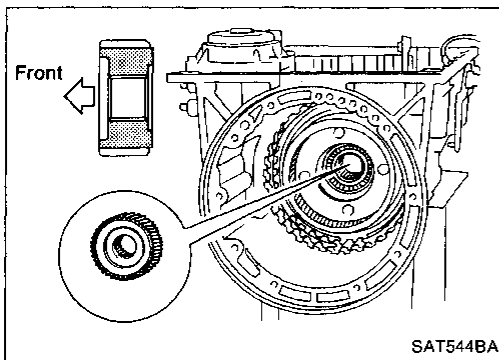

1. Install front side clutch and gear components.
  - a. Install rear sun gear on transmission case.
    - **Pay attention to its direction.**

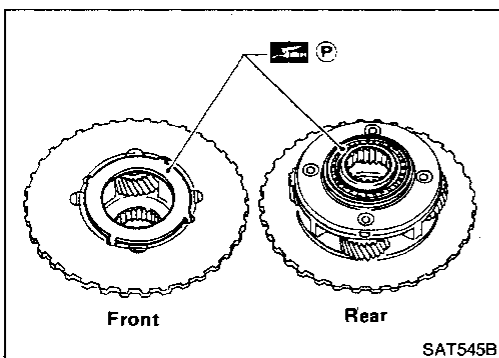

- b. Install needle bearing race on front of front planetary carrier.
  - **Apply petroleum jelly to needle bearing.**
- c. Install needle bearing on rear of front planetary carrier.
  - **Apply petroleum jelly to bearing.**
  - **Pay attention to its direction — Black side goes to front.**

## ASSEMBLY

### Adjustment (Cont'd)

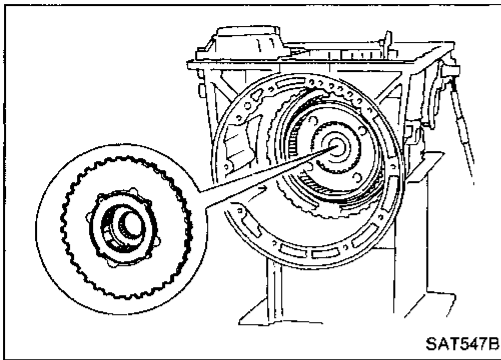

d. Install front planetary carrier on forward clutch drum.

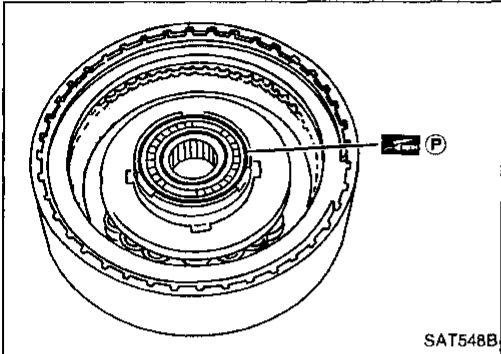

e. Install needle bearing on rear of high clutch.

● Apply petroleum jelly to bearing.

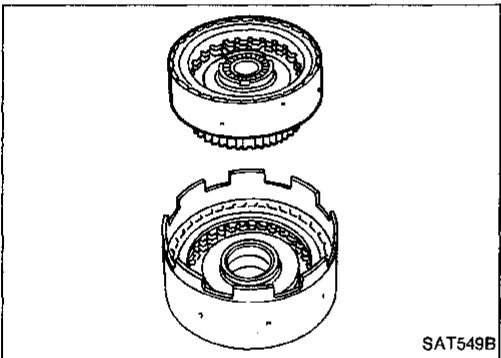

f. Install high clutch assembly onto reverse clutch assembly.

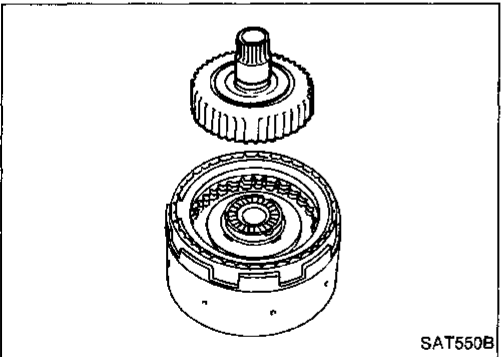

g. Install high clutch hub onto high clutch assembly.

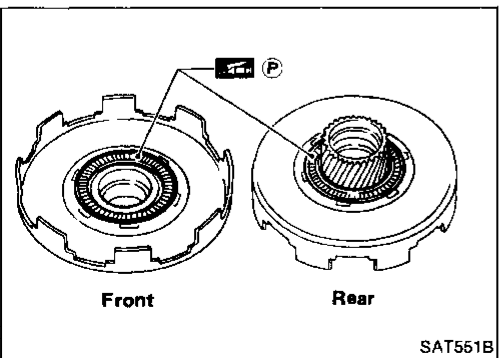

h. Install needle bearings onto front sun gear.

● Apply petroleum jelly to needle bearings.



# ASSEMBLY

## Adjustment (Cont'd)

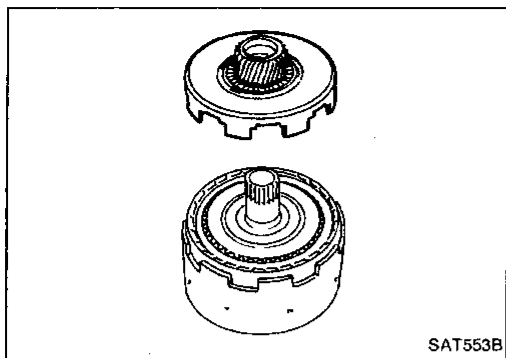

- i. Install front sun gear onto reverse clutch assembly.

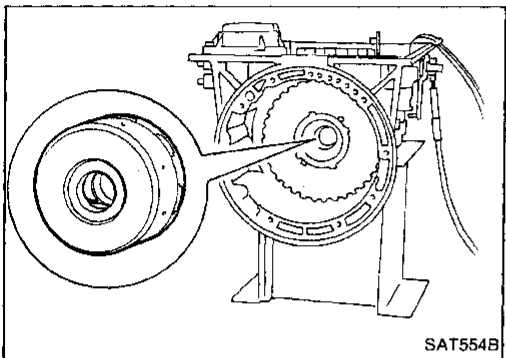

- j. Install clutch pack into transmission case.

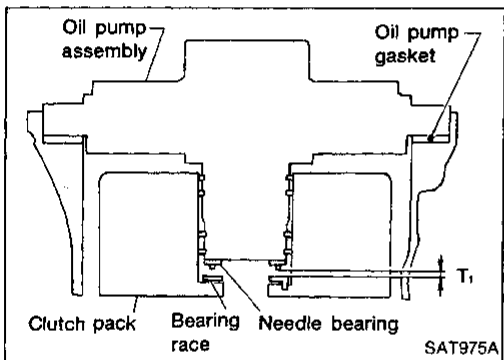

2. Adjust total end play.  
**Total end play "T<sub>1</sub>":**  
**0.25 - 0.55 mm (0.0098 - 0.0217 in)**

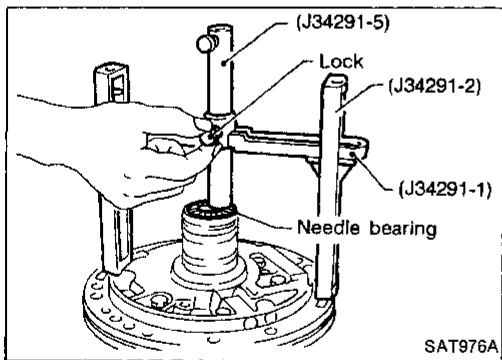

- a. With needle bearing installed, place J34291-1 (bridge), J34291-2 (legs) and the J34291-5 (gauging cylinder) onto oil pump. The long ends of legs should be placed firmly on machined surface of oil pump assembly and gauging cylinder should rest on top of the needle bearing. Lock gauging cylinder in place with set screw.

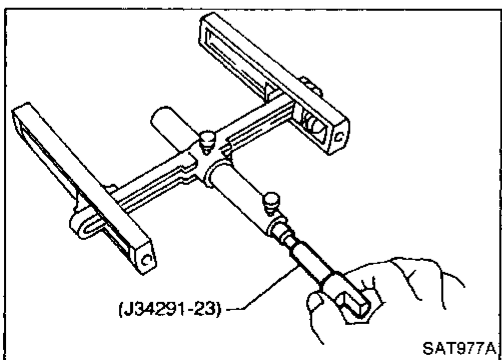

- b. Install J34291-23 (gauging plunger) into gauging cylinder.

GI

MA

EM

LC

EF &  
EC

FE

AT

PD

FA

RA

BR

ST

RS

BT

HA

EL

IDX

## ASSEMBLY

### Adjustment (Cont'd)

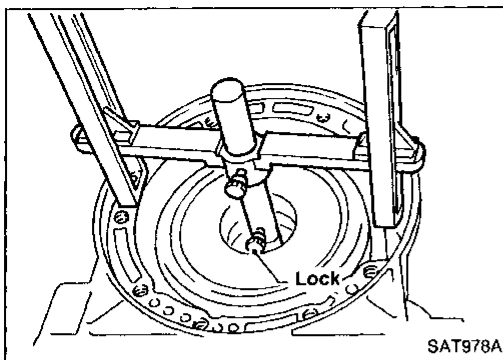

- c. With original bearing race installed inside reverse clutch drum, place shim selecting gauge with its legs on machined surface of transmission case (no gasket) and allow gauging plunger to rest on bearing race. Lock gauging plunger in place with set screw.

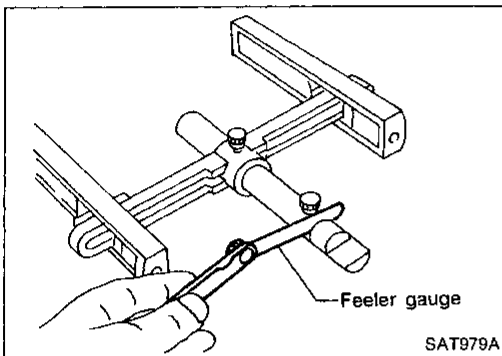

- d. Remove Tool and use feeler gauge to measure gap between gauging cylinder and gauging plunger. This measurement should give exact total end play.

**Total end play "T<sub>1</sub>":**

**0.25 - 0.55 mm (0.0098 - 0.0217 in)**

- If end play is out of specification, decrease or increase thickness of oil pump cover bearing race as necessary.

**Available oil pump cover bearing race:**

**Refer to SDS, AT-192.**

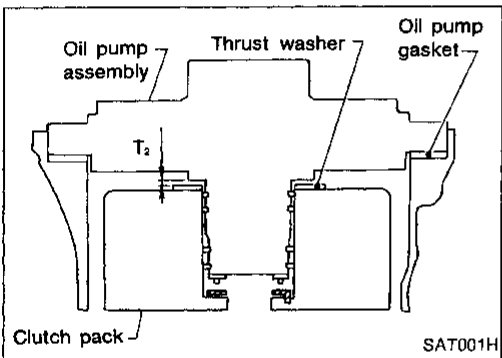

3. Adjust reverse clutch drum end play.

**Reverse clutch drum end play "T<sub>2</sub>":**

**0.55 - 0.90 mm (0.0217 - 0.0354 in)**

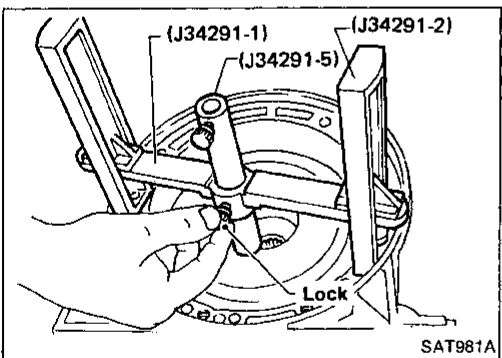

- a. Place J34291-1 (bridge), J34291-2 (legs) and J34291-5 (gauging cylinder) on machined surface of transmission case (no gasket) and allow gauging cylinder to rest on front thrust surface of reverse clutch drum. Lock cylinder in place with set screw.

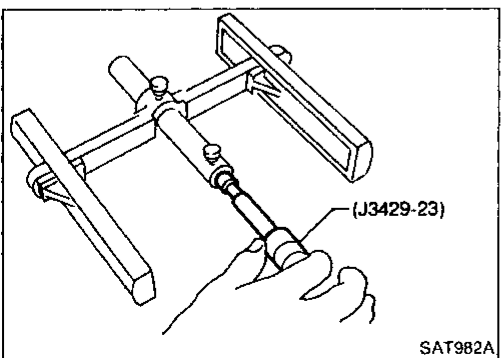

- b. Install J34291-23 (gauging plunger) into gauging cylinder.

## ASSEMBLY

### Adjustment (Cont'd)

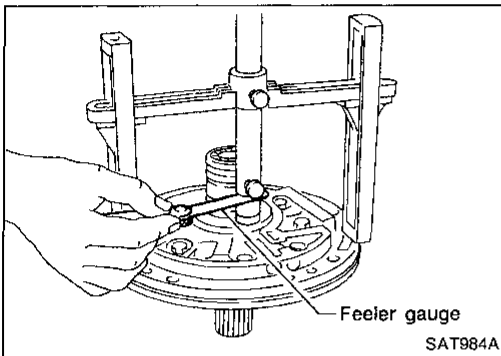
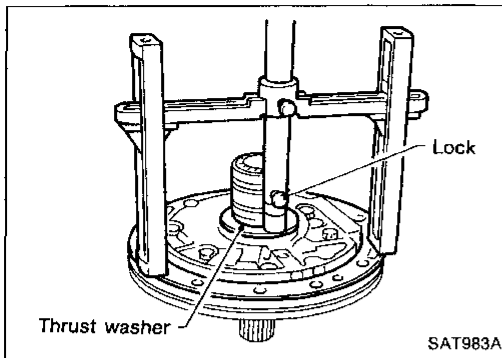

- c. With original thrust washer installed on oil pump, place shim setting gauge legs onto machined surface of oil pump assembly and allow gauging plunger to rest on thrust washer. Lock plunger in place with set screw.

- d. Use feeler gauge to measure gap between gauging plunger and gauging cylinder. This measurement should give you exact reverse clutch drum end play.

**Reverse clutch drum end play "T<sub>2</sub>":**  
0.55 - 0.90 mm (0.0217 - 0.0354 in)

- If end play is out of specification, decrease or increase thickness of oil pump thrust washer as necessary.

**Available oil pump thrust washer:**  
Refer to SDS, AT-192.

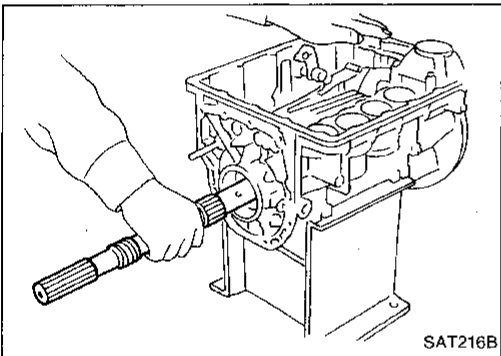

### Assembly (2)

1. Install output shaft and parking gear.
    - a. Insert output shaft from rear of transmission case while slightly lifting front internal gear.
- **Do not force output shaft against front of transmission case.**

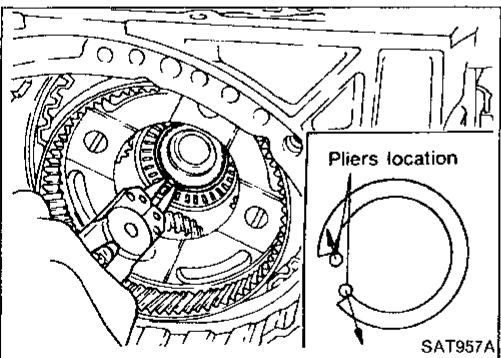

- b. Carefully push output shaft against front of transmission case. Install snap ring on front of output shaft.
- **Check to be sure output shaft cannot be removed in rear direction.**

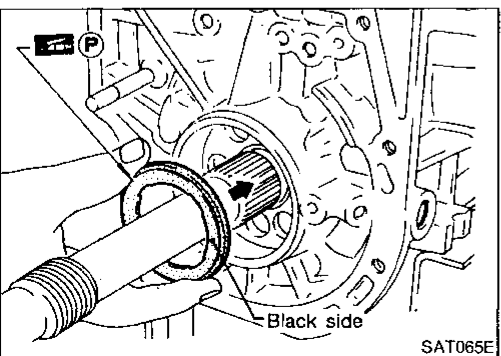

- c. Install needle bearing on transmission case.
- **Pay attention to its direction — Black side goes to rear.**
  - **Apply petroleum jelly to needle bearing.**

## ASSEMBLY

### Assembly (2) (Cont'd)

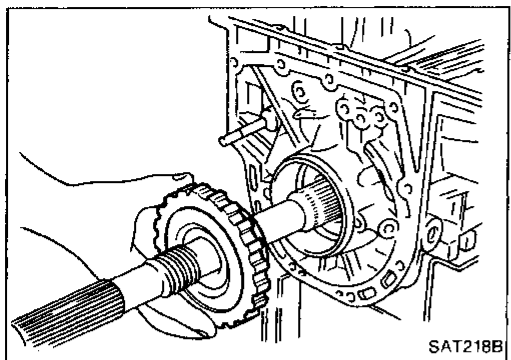

- d. Install parking gear on transmission case.

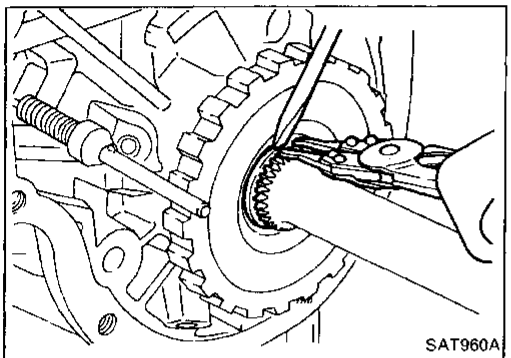

- e. Install snap ring on rear of output shaft.
- **Check to be sure output shaft cannot be removed in forward direction.**

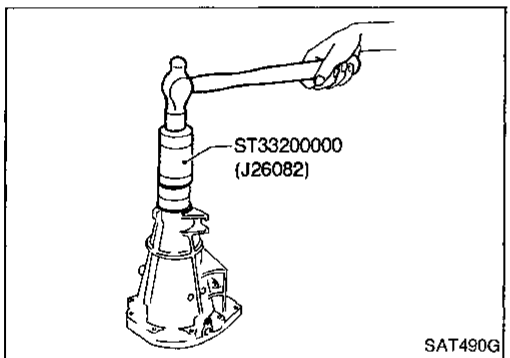

2. Install rear extension.
- a. Install oil seal on rear extension.
- **Apply ATF to oil seal.**

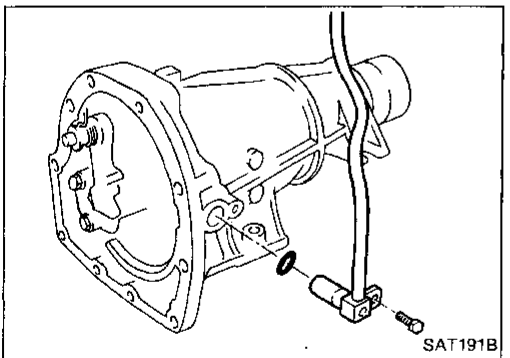

- b. Install O-ring on revolution sensor.
- **Apply ATF to O-ring.**
- c. Install revolution sensor on rear extension.

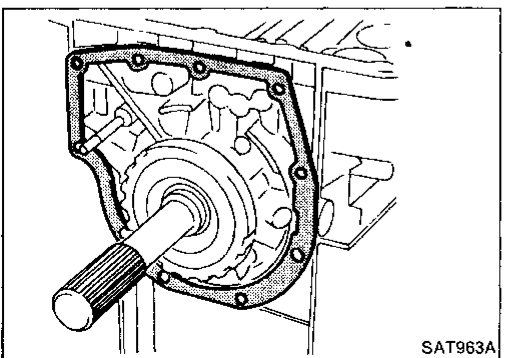

- d. Install rear extension gasket on transmission case.

# ASSEMBLY

## Assembly (2) (Cont'd)

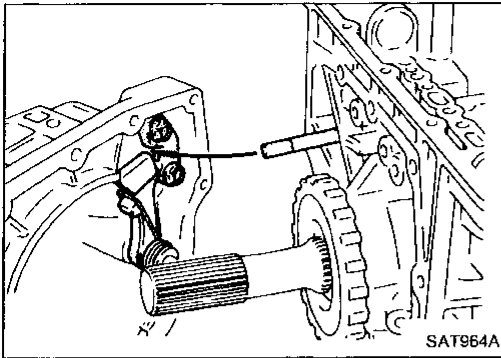

e. Install parking rod on transmission case.

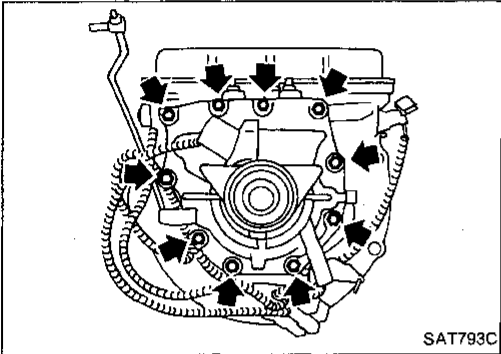

f. Install rear extension on transmission case.

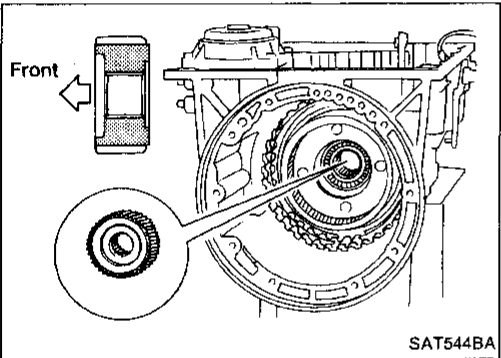

3. Install front side clutch and gear components.

a. Install rear sun gear on transmission case.

● **Pay attention to its direction.**

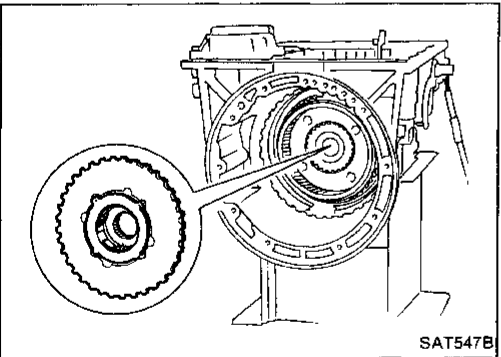

b. Make sure needle bearing is on front of front planetary carrier.

● **Apply petroleum jelly to needle bearing.**

c. Make sure needle bearing is on rear of front planetary carrier.

● **Apply petroleum jelly to bearing.**

● **Pay attention to its direction — Black side goes to front.**

d. While rotating forward clutch drum clockwise, install front planetary carrier on forward clutch drum.

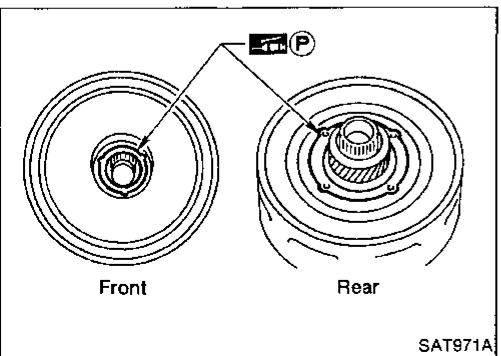

e. Make sure bearing races are on front and rear of clutch pack.

● **Apply petroleum jelly to bearing races.**

● **Securely engage pawls of bearing races with holes in clutch pack.**

GI

MA

EM

LC

EF &  
EC

FE

AT

PD

FA

RA

BR

ST

RS

BT

HA

EL

IDX

## ASSEMBLY

### Assembly (2) (Cont'd)

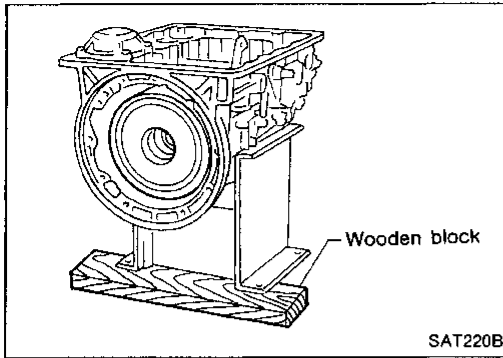

- f. Install clutch pack into transmission case.

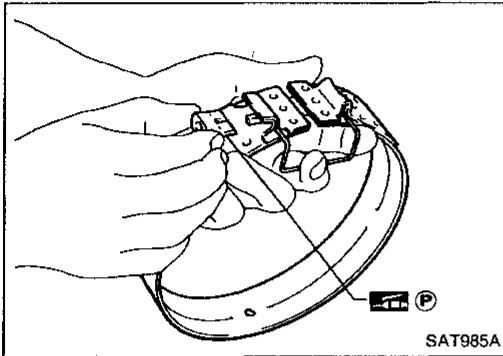

4. Install brake band and band strut.  
a. Install band strut on brake band.  
● **Apply petroleum jelly to band strut.**

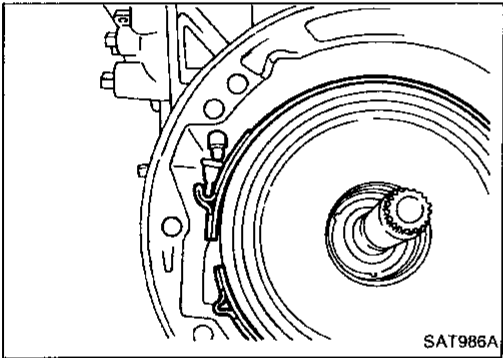

- b. Place brake band on periphery of reverse clutch drum, and insert band strut into end of band servo piston stem.

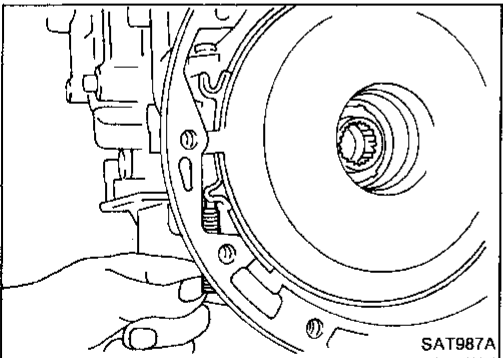

- c. Install anchor end bolt on transmission case. Then, tighten anchor end bolt just enough so that reverse clutch drum (clutch pack) will not tilt forward.

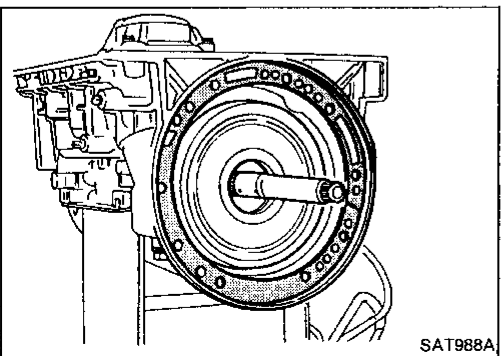

5. Install input shaft on transmission case.  
● **Pay attention to its direction — O-ring groove side is front.**  
6. Install gasket on transmission case.

# ASSEMBLY

## Assembly (2) (Cont'd)

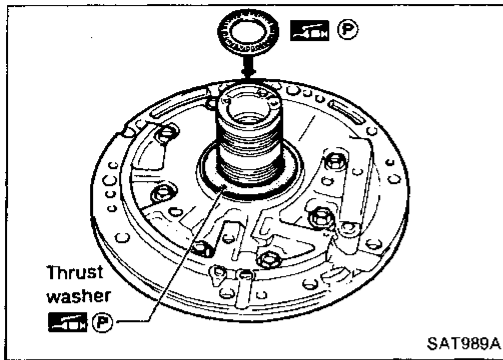

7. Install oil pump assembly.
  - a. Install needle bearing on oil pump assembly.
    - **Apply petroleum jelly to the needle bearing.**
  - b. Install selected thrust washer on oil pump assembly.
    - **Apply petroleum jelly to thrust washer.**

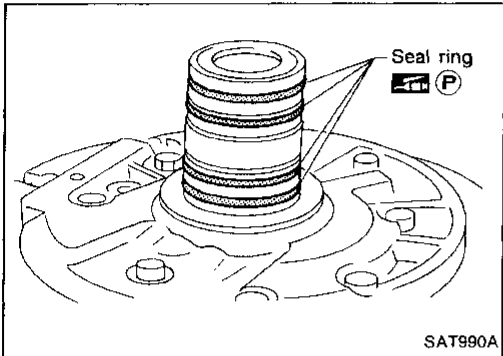

- c. Carefully install seal rings into grooves and press them into the petroleum jelly so that they are a tight fit.

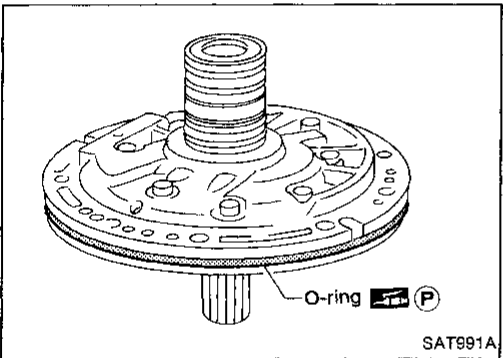

- d. Install O-ring on oil pump assembly.
          - **Apply petroleum jelly to O-ring.**

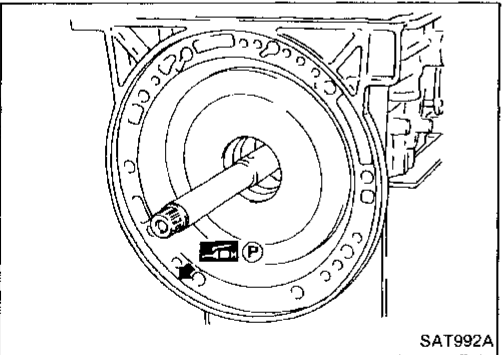

- e. Apply petroleum jelly to mating surface of transmission case and oil pump assembly.

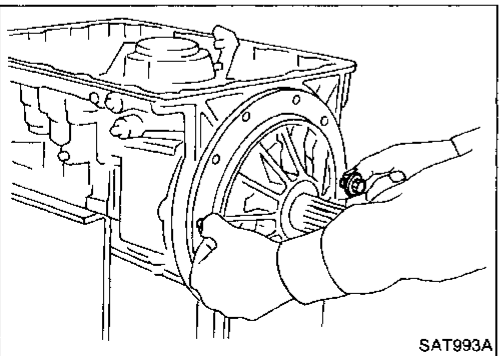

- f. Install oil pump assembly.
              - **Install two converter housing securing bolts in bolt holes in oil pump assembly as guides.**

GI

MA

EM

LC

EF &  
EC

FE

AT

PD

FA

RA

BR

ST

RS

BT

HA

EL

IDX

# ASSEMBLY

## Assembly (2) (Cont'd)

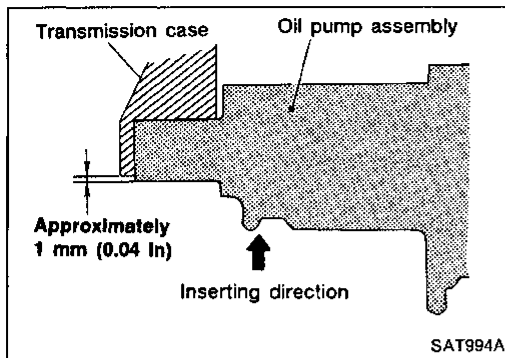

- Insert oil pump assembly to the specified position in transmission, as shown at left.

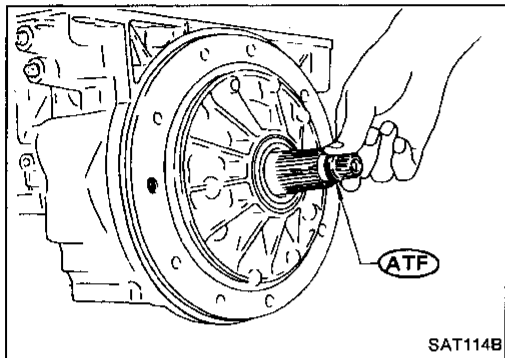

8. Install O-ring on input shaft.
- Apply ATF to O-rings.

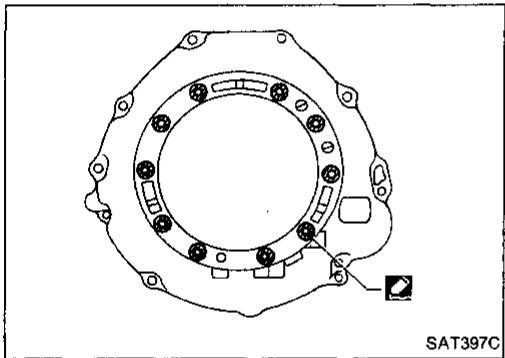

9. Install converter housing.
    - a. Apply recommended sealant (Nissan genuine part: KP610-00250 or equivalent) to outer periphery of bolt holes in converter housing.
- Do not apply too much sealant.

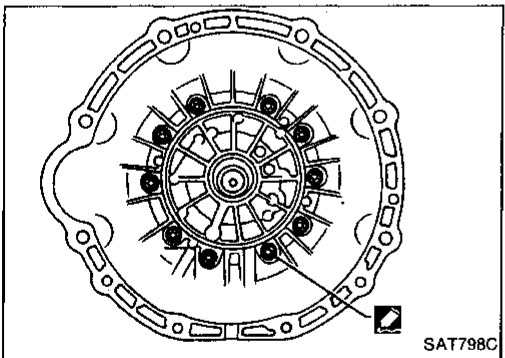

- b. Apply recommended sealant (Nissan genuine part: KP610-00250 or equivalent) to seating surfaces of bolts that secure front of converter housing.

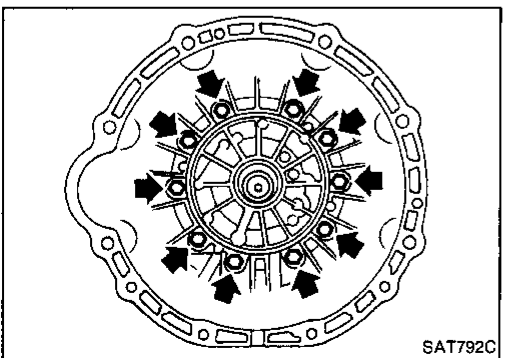

- c. Install converter housing on transmission case.



# ASSEMBLY

## Assembly (2) (Cont'd)

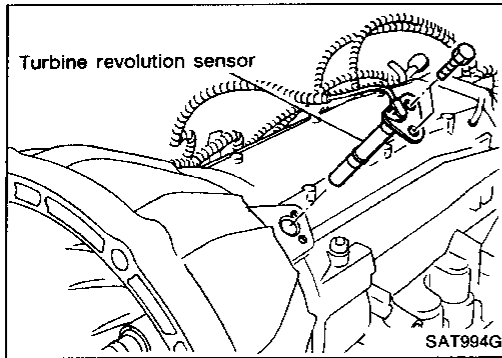

10. Install turbine revolution sensor.

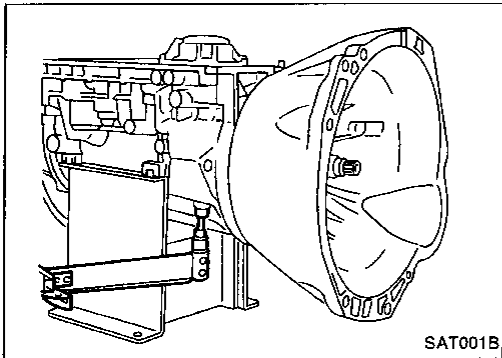

11. Adjust brake band.
- Tighten anchor end bolt to specified torque.  
**Anchor end bolt:**  
 $\square$ : 4 - 6 N·m (0.4 - 0.6 kg-m, 2.9 - 4.3 ft-lb)
  - Back off anchor end bolt two and a half turns.

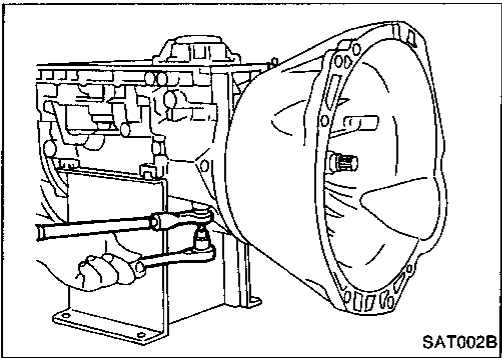

c. While holding anchor end pin, tighten lock nut.

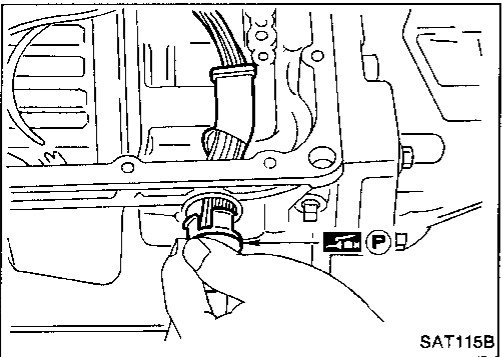

12. Install terminal cord assembly.
- Install O-ring on terminal cord assembly.  
**● Apply petroleum jelly to O-ring.**
  - Compress terminal cord assembly stopper and install terminal cord assembly on transmission case.

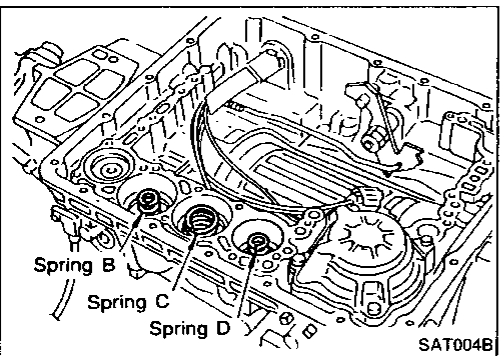

13. Install control valve assembly.
- Install accumulator piston return springs B, C and D.

**Free length of return springs:**

Unit: mm (in)

Item	Accumulator		
	B	C	D
Free length	66.0 (2.598)	45.0 (1.772)	58.4 (2.299)

# ASSEMBLY

## Assembly (2) (Cont'd)

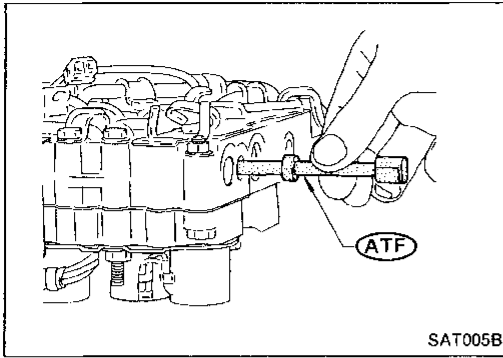

- b. Install manual valve on control valve.
- **Apply ATF to manual valve.**

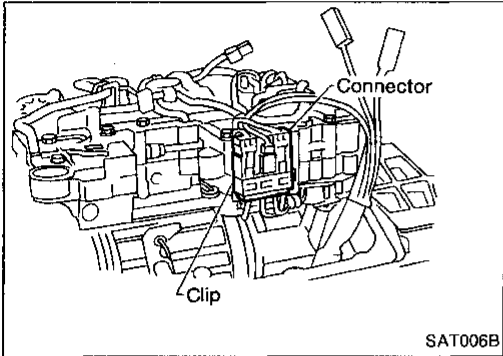

- c. Place control valve assembly on transmission case. Connect solenoid connector for upper body.
- d. Install connector clip.

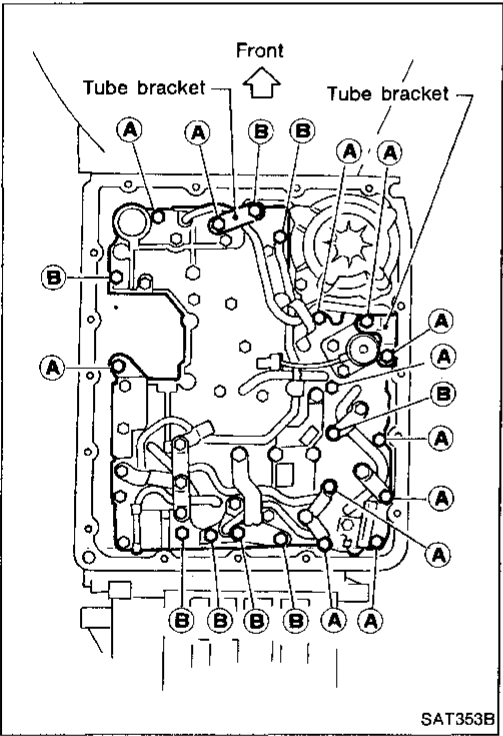

- e. Install control valve assembly on transmission case.
- f. Install connector tube brackets and tighten bolts Ⓐ and Ⓑ.
- **Check that terminal assembly harness does not catch.**

Bolt	ℓ mm (in)	 ℓ
Ⓐ	33 (1.30)	
Ⓑ	45 (1.77)	

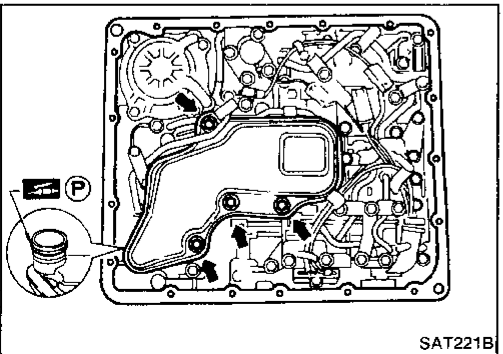

- g. Install O-ring on oil strainer.
- **Apply petroleum jelly to O-ring.**
- h. Install oil strainer on control valve.

## ASSEMBLY

### Assembly (2) (Cont'd)

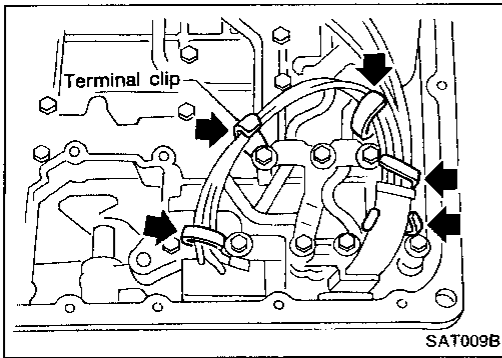

- i. Securely fasten terminal harness with clips.

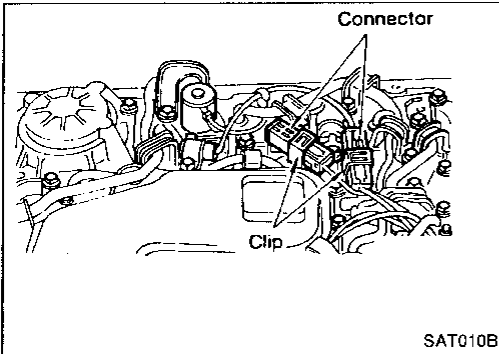

- j. Install torque converter clutch solenoid valve and fluid temperature sensor connectors.

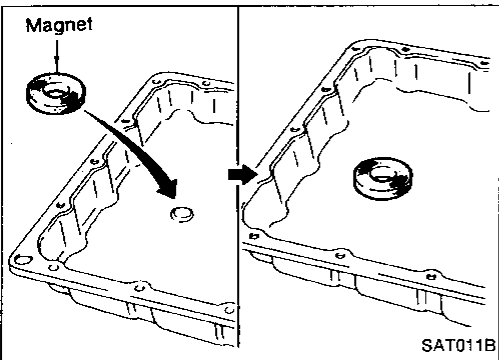

14. Install oil pan.
  - a. Attach a magnet to oil pan.

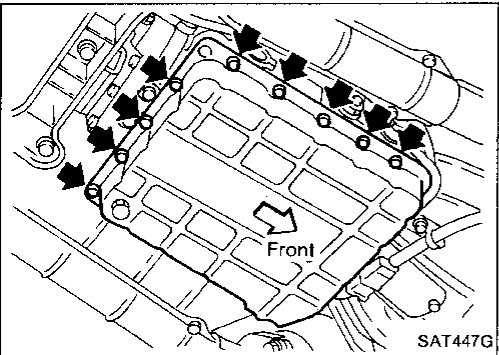

- b. Install new oil pan gasket on transmission case.
- c. Install oil pan and bracket on transmission case.
  - Always replace oil pan bolts as they are self-sealing bolts.
  - Before installing bolts, remove traces of sealant and oil from mating surface and thread holes.
  - Tighten four bolts in a criss-cross pattern to prevent dislocation of gasket.
- d. Tighten drain plug.

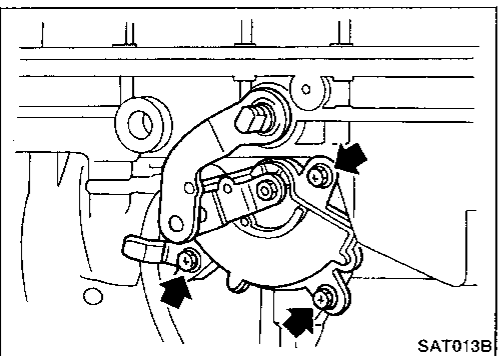

15. Install inhibitor switch.
  - a. Check that manual shaft is in "1" position.
  - b. Temporarily install inhibitor switch on manual shaft.
  - c. Move manual shaft to "N".

GI

MA

EM

LC

EF &  
EC

FE

AT

PD

FA

RA

BR

ST

RS

BT

HA

EL

IDX

## ASSEMBLY

### Assembly (2) (Cont'd)

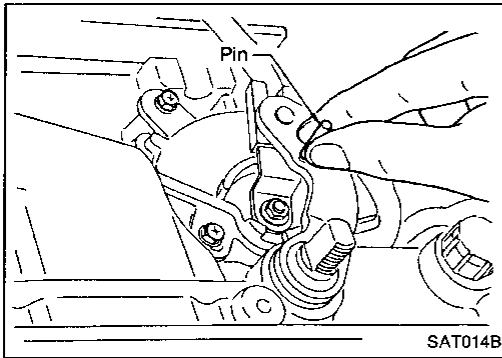

- d. Tighten bolts while inserting 4.0 mm (0.157 in) dia. pin vertically into locating holes in inhibitor switch and manual shaft.

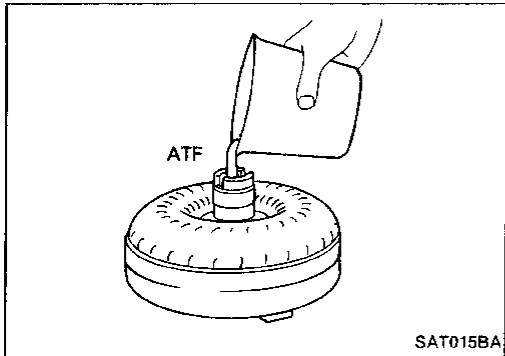

16. Install torque converter.
- a. Pour ATF into torque converter.
- Approximately 2 liters (2-1/8 US qt, 1-3/4 Imp qt) of fluid are required for a new torque converter.
  - When reusing old torque converter, add the same amount of fluid as was drained.

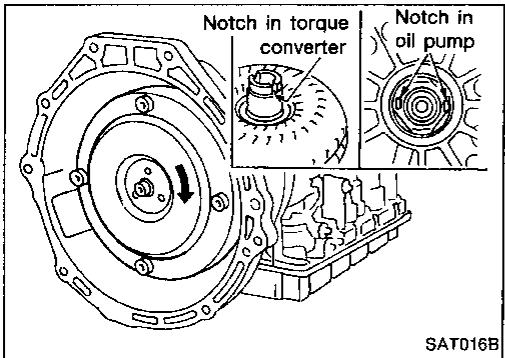

- b. Install torque converter while aligning notches and oil pump.

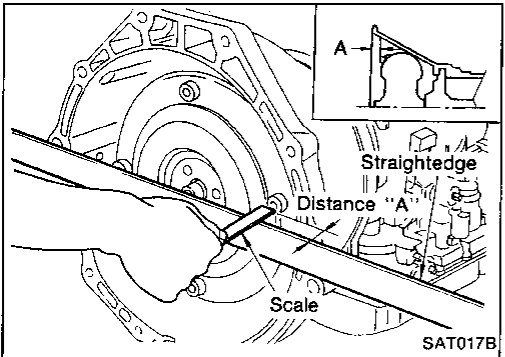

- c. Measure distance A to check that torque converter is in proper position.

**Distance "A":**

**22 mm (0.87 in) or more**

**Refer to SDS, AT-192.**

# SERVICE DATA AND SPECIFICATIONS (SDS)

## General Specifications

Engine	VH45DE
Automatic transmission model	RE4R03A
Transmission model code number	51X79
Stall torque ratio	2.0 : 1
Transmission gear ratio	
1st	2.569
2nd	1.479
Top	1.000
O.D.	0.694
Reverse	2.275
Recommended oil	Genuine Nissan ATF or equivalent
Oil capacity   ℓ (US qt, Imp qt)	10.5 (11-1/8, 9-1/4)

## Specifications and Adjustment

### VEHICLE SPEED WHEN SHIFTING GEARS

Throttle position	Vehicle speed km/h (MPH)						
	D <sub>1</sub> → D <sub>2</sub>	D <sub>2</sub> → D <sub>3</sub>	D <sub>3</sub> → D <sub>4</sub>	D <sub>4</sub> → D <sub>3</sub>	D <sub>3</sub> → D <sub>2</sub>	D <sub>2</sub> → D <sub>1</sub>	1 <sub>2</sub> → 1 <sub>1</sub>
Full throttle	78 - 82 (48 - 51)	135 - 143 (84 - 89)	201 - 211 (125 - 131)	194 - 204 (121 - 127)	125 - 133 (78 - 83)	43 - 47 (27 - 29)	53 - 57 (33 - 35)
Half throttle	50 - 54 (31 - 34)	95 - 101 (59 - 63)	138 - 146 (86 - 91)	80 - 88 (50 - 55)	27 - 33 (17 - 21)	10 - 14 (6 - 9)	53 - 57 (33 - 35)

### VEHICLE SPEED WHEN PERFORMING AND RELEASING LOCK-UP

Throttle position	Selector lever position [Shift position]	Vehicle speed km/h (MPH)	
		Lock-up "ON"	Lock-up "OFF"
Full throttle	D [D <sub>4</sub> ]	202 - 210 (126 - 130)	195 - 203 (121 - 126)
	3 [3 <sub>s</sub> ]	114 - 122 (71 - 76)	108 - 116 (67 - 72)
Half throttle	D [D <sub>4</sub> ]	138 - 146 (86 - 91)	103 - 111 (64 - 69)
	3 [3 <sub>s</sub> ]	109 - 117 (68 - 73)	103 - 111 (64 - 69)

### STALL REVOLUTION

Stall revolution rpm
2,100 - 2,300

### LINE PRESSURE

Engine speed rpm	Line pressure kPa (kg/cm <sup>2</sup> , psi)	
	D, 3, 2 and 1 positions	R position
Idle	451 - 490 (4.6 - 5.0, 65 - 71)	628 - 667 (6.4 - 6.8, 91 - 97)
Stall	1,020 - 1,098 (10.4 - 11.2, 148 - 159)	1,422 - 1,510 (14.5 - 15.4, 206 - 219)

# SERVICE DATA AND SPECIFICATIONS (SDS)

## Specifications and Adjustment (Cont'd)

### RETURN SPRINGS

Unit: mm (in)

Parts		Item			
		Part No.	Free length	Outer diameter	
Control valve	Upper body	Torque converter relief valve spring	31742-41X23	38.0 (1.496)	9.0 (0.354)
		Pressure regulator valve spring	31742-41X24	44.02 (1.7331)	14.0 (0.551)
		Pressure modifier valve spring	31742-41X19	31.95 (1.2579)	6.8 (0.268)
		Shuttle shift valve D spring	31762-41X00	26.5 (1.043)	6.0 (0.236)
		4-2 sequence valve spring	31756-41X00	29.1 (1.146)	6.95 (0.2736)
		Shift valve B spring	31762-41X01	25.0 (0.984)	7.0 (0.276)
		4-2 relay valve spring	31756-41X00	29.1 (1.146)	6.95 (0.2736)
		Shift valve A spring	31762-41X01	25.0 (0.984)	7.0 (0.276)
		Overrun clutch control valve spring	31762-41X03	23.6 (0.929)	7.0 (0.276)
		Overrun clutch reducing valve spring	31742-41x14	38.9 (1.531)	7.0 (0.276)
		Shuttle shift valve S spring	31762-41X04	51.0 (2.008)	5.65 (0.2224)
		Pilot valve spring	31742-41X13	25.7 (1.012)	9.1 (0.358)
		Torque converter clutch control valve spring	31742-41X22	18.5 (0.728)	13.0 (0.512)
	Lower body	Modifier accumulator piston spring	31742-27X70	31.4 (1.236)	9.8 (0.386)
		1st reducing valve spring	31756-60X00	29.5 (1.161)	7.0 (0.276)
		3-2 timing valve spring	31742-41X08	20.55 (0.8091)	6.75 (0.2657)
		Servo charger valve spring	31742-41X06	23.0 (0.906)	6.7 (0.264)
Reverse clutch	16 pcs	31505-51X00	37.18 (1.4638)	14.8 (0.583)	
High clutch	16 pcs	31505-21X03	22.06 (0.8685)	11.6 (0.457)	
Forward clutch (Overrun clutch)	20 pcs	31505-51X04	36.8 (1.449)	9.8 (0.386)	
Low & reverse brake	Inner spring	16 pcs	31505-51X06	20.43 (0.8043)	10.3 (0.406)
	Outer spring	16 pcs	31505-51X05	20.35 (0.8012)	13.0 (0.512)
Band servo	Spring A		31605-41X17	52.0 (2.047)	38.7 (1.524)
	Spring B		31605-41X01	29.0 (1.142)	27.6 (1.087)
Accumulator	Accumulator A		31605-41X02	43.0 (1.693)	18 (0.71)
	Accumulator B		31605-41X10	66.0 (2.598)	18.8 (0.740)
	Accumulator C		31605-51X01	45.0 (1.772)	29.3 (1.154)
	Accumulator D		31605-41X06	58.4 (2.299)	17.3 (0.681)

# SERVICE DATA AND SPECIFICATIONS (SDS)

## Specifications and Adjustment (Cont'd)

### ACCUMULATOR O-RING

Accumulator	Diameter mm (in)			
	A	B	C	D
Small diameter end	29 (1.14)	32 (1.26)	45 (1.77)	29 (1.14)
Large diameter end	45 (1.77)	50 (1.97)	50 (1.97)	45 (1.77)

### CLUTCHES AND BRAKES

Reverse clutch		
Number of drive plates	3	
Number of driven plates	3	
Thickness of drive plate mm (in)	Standard	
	1.90 - 2.05 (0.0748 - 0.0807)	
Wear limit	1.8 (0.071)	
	Clearance mm (in)	
Standard	0.6 - 0.9 (0.024 - 0.035)	
	Allowable limit	
		1.4 (0.055)
Thickness of retaining plate	Thickness mm (in)	Part number
	4.4 (0.173)	31537-51X61
	4.6 (0.181)	31537-51X00
	4.8 (0.189)	31537-51X01
	5.0 (0.197)	31537-51X02
High clutch		
Number of drive plates	6	
Number of driven plates	6	
Thickness of drive plate mm (in)	Standard	
	1.52 - 1.67 (0.0598 - 0.0657)	
Wear limit	1.4 (0.055)	
	Clearance mm (in)	
Standard	1.8 - 2.2 (0.071 - 0.087)	
	Allowable limit	
		3.4 (0.134)
Thickness of retaining plate	Thickness mm (in)	Part number
	4.4 (0.173)	31537-51X61
	4.6 (0.181)	31537-51X00
	4.8 (0.189)	31537-51X01
	5.0 (0.197)	31537-51X02
	5.2 (0.205)	31537-51X03
	5.4 (0.213)	31537-51X04

Forward clutch		
Number of drive plates	9	
Number of driven plates	9	
Thickness of drive plate mm (in)	Standard	
	1.90 - 2.05 (0.0748 - 0.0807)	
Wear limit	1.8 (0.071)	
	Clearance mm (in)	
Standard	0.45 - 0.85 (0.0177 - 0.0335)	
	Allowable limit	
		2.2 (0.087)
Thickness of retaining plate	Thickness mm (in)	Part number
	4.2 (0.165)	31537-51X67
	4.4 (0.173)	31537-51X05
	4.6 (0.181)	31537-51X06
	4.8 (0.189)	31537-51X07
	5.0 (0.197)	31537-51X08
	5.2 (0.205)	31537-51X09
5.4 (0.213)	31537-51X10	
Overrun clutch		
Number of drive plates	5	
Number of driven plates	5	
Thickness of drive plate mm (in)	Standard	
	1.92 - 2.07 (0.0756 - 0.0815)	
Wear limit	1.4 (0.055)	
	Clearance mm (in)	
Standard	1.0 - 1.4 (0.039 - 0.055)	
	Allowable limit	
		2.4 (0.094)
Thickness of retaining plate	Thickness mm (in)	Part number
	4.0 (0.157)	31537-51X12
	4.2 (0.165)	31537-51X13
	4.4 (0.173)	31537-51X14
	4.6 (0.181)	31537-51X15
	4.8 (0.189)	31537-51X64
	5.0 (0.197)	31537-51X65
5.2 (0.205)	31537-51X66	

GI  
 MA  
 EM  
 LC  
 EF & EC  
 FE  
 AT  
 PD  
 FA  
 RA  
 BR  
 ST  
 RS  
 BT  
 HA  
 EL  
 IDX

# SERVICE DATA AND SPECIFICATIONS (SDS)

## Specifications and Adjustment (Cont'd)

<b>Low &amp; reverse brake</b>		
Number of drive plates		8
Number of driven plates		8
Thickness of drive plate mm (in)		
Standard		1.52 - 1.67 (0.0598 - 0.0657)
Wear limit		1.4 (0.055)
Clearance mm (in)		
Standard		0.90 - 1.20 (0.0354 - 0.0472)
Allowable limit		2.4 (0.094)
Thickness of retaining plate	Thickness mm (in)	Part number
	4.2 (0.165)	31667-51X10
	4.4 (0.173)	31667-51X00
	4.6 (0.181)	31667-51X01
	4.8 (0.189)	31667-51X02
	5.0 (0.197)	31667-51X03
	5.2 (0.205)	31667-51X04
	5.4 (0.213)	31667-51X05
	5.6 (0.220)	31667-51X06
	5.8 (0.228)	31667-51X07
6.0 (0.236)	31667-51X08	
6.2 (0.244)	31667-51X09	
<b>Brake band</b>		
Anchor end bolt tightening torque N-m (kg-m, ft-lb)		4 - 6 (0.4 - 0.6, 2.9 - 4.3)
Number of returning revolutions for anchor end bolt		2.5

### OIL PUMP AND LOW ONE-WAY CLUTCH

Oil pump clearance mm (in)	
Cam ring — oil pump housing	
Standard	0.01 - 0.024 (0.0004 - 0.0009)
Rotor, vanes and control piston — oil pump housing	
Standard	0.03 - 0.044 (0.0012 - 0.0017)
Seal ring clearance mm (in)	
Standard	0.10 - 0.25 (0.0039 - 0.0098)
Allowable limit	0.25 (0.0098)

### TOTAL END PLAY

Total end play "T <sub>1</sub> "	0.25 - 0.55 mm (0.0098 - 0.0217 in)	
Thickness of oil pump cover bearing race	Thickness mm (in)	Part number
	0.8 (0.031)	31435-41X01
	1.0 (0.039)	31435-41X02
	1.2 (0.047)	31435-41X03
	1.4 (0.055)	31429-21X03
	1.6 (0.063)	31429-21X04
	1.8 (0.071)	31429-21X05
2.0 (0.079)	31429-21X06	

### REVERSE CLUTCH DRUM END PLAY

Reverse clutch drum end play "T <sub>2</sub> "	0.55 - 0.90 mm (0.0217 - 0.0354 in)	
Thickness of oil pump thrust washer	Thickness mm (in)	Part number
	0.7 (0.028)	31528-21X00
	0.9 (0.035)	31528-21X01
	1.1 (0.043)	31528-21X02
	1.3 (0.051)	31528-21X03
	1.5 (0.059)	31528-21X04
	1.7 (0.067)	31528-21X05
	1.9 (0.075)	31528-21X06

### REMOVAL AND INSTALLATION

Manual control linkage	
Number of returning revolutions for lock nut	1
Lock nut tightening torque	11 - 15 N-m (1.1 - 1.5 kg-m, 8 - 11 ft-lb)
Distance between end of clutch housing and torque converter	22.0 mm (0.866 in) or more