

# MAINTENANCE

## SECTION **MA**

GI

MA

EM

LC

EC

FE

AT

PD

FA

RA

BR

ST

RS

BT

HA

EL

IDX

## CONTENTS

<b>PRECAUTIONS</b> .....	2	<b>CHASSIS AND BODY MAINTENANCE</b> .....	16
Supplemental Restraint System (SRS) "AIR BAG" and "SEAT BELT PRE-TENSIONER".....	2	Checking Exhaust System.....	16
<b>GENERAL MAINTENANCE</b> .....	3	Checking A/T Fluid.....	16
<b>PERIODIC MAINTENANCE</b> .....	5	Changing A/T Fluid.....	17
Schedule 1.....	6	Checking Differential Gear Oil.....	17
Schedule 2.....	7	Changing Differential Gear Oil.....	17
<b>RECOMMENDED FLUIDS AND LUBRICANTS</b> .....	8	Balancing Wheels.....	17
Fluids and Lubricants.....	8	Tire Rotation.....	18
SAE Viscosity Number.....	8	Checking Brake Fluid Level and Leaks.....	18
Anti-freeze Coolant Mixture Ratio.....	9	Checking Brake Lines and Cables.....	18
<b>ENGINE MAINTENANCE</b> .....	10	Changing Brake Fluid.....	18
Checking Drive Belts.....	10	Checking Disc Brake.....	18
Changing Engine Coolant.....	11	Checking Steering Gear and Linkage.....	19
Checking Fuel Lines.....	12	Checking Power Steering Fluid and Lines.....	19
Changing Fuel Filter.....	12	Lubricating Locks, Hinges and Hood Latches.....	20
Changing Air Cleaner Filter.....	13	Checking Seat Belts, Buckles, Retractors, Anchors and Adjusters.....	20
Changing Engine Oil.....	13	<b>SERVICE DATA AND SPECIFICATIONS (SDS)</b> .....	21
Changing Oil Filter.....	14	Engine Maintenance.....	21
Changing Spark Plugs.....	14		
Checking EVAP Vapor Purge Lines.....	15		

## PRECAUTIONS

---

### **Supplemental Restraint System (SRS) “AIR BAG” and “SEAT BELT PRE-TENSIONER”**

The Supplemental Restraint System “Air Bag” and “Seat Belt Pre-tensioner”, used along with a seat belt, help to reduce the risk or severity of injury to the driver and front passenger in a frontal collision. The Supplemental Restraint System consists of air bag modules (located in the center of the steering wheel and on the instrument panel on the passenger side), seat belt pre-tensioners, a diagnosis sensor unit, warning lamp, wiring harness and spiral cable. Information necessary to service the system safely is included in the **RS section** of this Service Manual.

**WARNING:**

- **To avoid rendering the SRS inoperative, which could increase the risk of personal injury or death in the event of a collision which would result in air bag inflation, all maintenance must be performed by an authorized INFINITI dealer.**
- **Improper maintenance, including incorrect removal and installation of the SRS, can lead to personal injury caused by unintentional activation of the system.**
- **Do not use electrical test equipment on any circuit related to the SRS unless instructed to in this Service Manual. SRS wiring harnesses are covered with yellow insulation either just before the harness connectors or for the complete harness, for easy identification.**

## GENERAL MAINTENANCE

General maintenance includes those items which should be checked during the normal day-to-day operation of the vehicle. They are essential if the vehicle is to continue operating properly. The owners can perform the checks and inspections themselves or they can have their INFINITI dealers do them.

Item	Reference page	GI
<b>OUTSIDE THE VEHICLE</b>		
The maintenance items listed here should be performed from time to time, unless otherwise specified.		
<b>Tires</b> Check the pressure with a gauge periodically when at a service station, including the spare, and adjust to the specified pressure if necessary. Check carefully for damage, cuts or excessive wear.	—	EM
<b>Wheel nuts</b> When checking the tires, make sure no nuts are missing, and check for any loose nuts. Tighten if necessary.	—	LC
<b>Tire rotation</b> Tires should be rotated every 12,000 km (7,500 miles).	MA-18	
<b>Wheel alignment and balance</b> If the vehicle should pull to either side while driving on a straight and level road, or if you detect uneven or abnormal tire wear, there may be a need for wheel alignment. If the steering wheel or seat vibrates at normal highway speeds, wheel balancing may be needed.	MA-17 FA-7 RA-5	EC FE
<b>Windshield wiper blades</b> Check for cracks or wear if they do not wipe properly.	—	
<b>Doors and engine hood</b> Check that all doors and the engine hood operate smoothly as well as the trunk lid. Also make sure that all latches lock securely. Lubricate hinges and latches if necessary. Make sure that the secondary latch keeps the hood from opening when the primary latch is released. When driving in areas using road salt or other corrosive materials, check lubrication frequently.	MA-20	AT PD FA
<b>INSIDE THE VEHICLE</b>		
The maintenance items listed here should be checked on a regular basis, such as when performing periodic maintenance, cleaning the vehicle, etc.		
<b>Lights</b> Make sure that the headlights, stop lights, tail lights, turn signal lights, and other lights are all operating properly and installed securely. Also check headlight aim.	—	RA
<b>Warning lights and buzzers/chimes</b> Make sure that all warning lights and buzzers/chimes are operating properly.	—	BR
<b>Windshield wiper and washer</b> Check that the wipers and washer operate properly and that the wipers do not streak.	—	ST
<b>Windshield defroster</b> Check that the air comes out of the defroster outlets properly and in sufficient quantity when operating the heater or air conditioner.	—	RS
<b>Steering wheel</b> Check that it has the specified play. Be sure to check for changes in the steering condition, such as excessive play, hard steering or strange noises. <b>Free play: Less than 35 mm (1.38 in)</b>	—	BT
<b>Seats</b> Check seat position controls such as seat adjusters, seatback recliner, etc. to make sure they operate smoothly and that all latches lock securely in every position. Check that the head restraints move up and down smoothly and that the locks (if equipped) hold securely in all latched positions. Check that the latches lock securely for folding-down rear seatbacks.	—	HA EL
<b>Seat belts</b> Check that all parts of the seat belt system (e.g. buckles, anchors, adjusters and retractors) operate properly and smoothly, and are installed securely. Check the belt webbing for cuts, fraying, wear or damage.	MA-20	IDX
<b>Brakes</b> Check that the brake does not pull the vehicle to one side when applied.	—	
<b>Brake pedal and booster</b> Check the pedal for smooth operation and make sure it has the proper distance under it when depressed fully. Check the brake booster function. Be sure to keep the floor mats away from the pedal.	BR-9 BR-14	

## GENERAL MAINTENANCE

Item	Reference page
<b>Parking brake</b> Check that the pedal has the proper travel and confirm that the vehicle is held securely on a fairly steep hill with only the parking brake applied.	BR-26
<b>Automatic transmission "Park" mechanism</b> Check that the brake pedal must be depressed for the selector lever to be moved from the "P" position. On a fairly steep hill check that the vehicle is held securely with the selector lever in the "P" position without applying any brakes.	—
<b>UNDER THE HOOD AND VEHICLE</b>	
The maintenance items listed here should be checked periodically (e.g. each time you check the engine oil or refuel).	
<b>Windshield washer fluid</b> Check that there is adequate fluid in the tank.	—
<b>Engine coolant level</b> Check the coolant level when the engine is cold.	MA-11
<b>Radiator and hoses</b> Check the front of the radiator and clean off any dirt, insects, leaves, etc., that may have accumulated. Make sure the hoses have no cracks, deformation, deterioration or loose connections.	—
<b>Brake fluid level</b> Make sure that the brake fluid level is between the "MAX" and "MIN" lines on the reservoir.	MA-18
<b>Battery</b> Check the fluid level in each cell. It should be between the "MAX" and "MIN" lines.	—
<b>Engine drive belts</b> Make sure that no belt is frayed, worn, cracked or oily.	MA-10
<b>Engine oil level</b> Check the level on the dipstick after parking the vehicle on a level spot and turning off the engine.	MA-13
<b>Power steering fluid level and lines</b> Check the level on the dipstick with the engine off. Check the lines for improper attachment, leaks, cracks, etc.	MA-19
<b>Automatic transmission fluid level</b> Check the level on the dipstick after putting the selector lever in "P" with the engine idling.	MA-16
<b>Exhaust system</b> Make sure there are no loose supports, cracks or holes. If the sound of the exhaust seems unusual or there is a smell of exhaust fumes, immediately locate the trouble and correct it.	MA-16
<b>Underbody</b> The underbody is frequently exposed to corrosive substances such as those used on icy roads or to control dust. It is very important to remove these substances, otherwise rust will form on the floor pan, frame, fuel lines and around the exhaust system. At the end of winter, the underbody should be thoroughly flushed with plain water, being careful to clean those areas where mud and dirt can easily accumulate.	—
<b>Fluid leaks</b> Check under the vehicle for fuel, oil, water or other fluid leaks after the vehicle has been parked for a while. Water dripping from the air conditioner after use is normal. If you should notice any leaks or gasoline fumes are evident, check for the cause and correct it immediately.	—
<b>Traction control system fluid level</b> Make sure that the fluid level is between the "MAX" and "MIN" lines on the reservoir.	BR-65

# PERIODIC MAINTENANCE

---

Two different maintenance schedules are provided, and should be used, depending upon the conditions in which the vehicle is mainly operated. **After 60,000 miles (96,000 km) or 48 months, continue the periodic maintenance at the same mileage/time intervals.**

## SCHEDULE 1

Follow Periodic Maintenance Schedule 1 if your driving habits frequently includes one or more of the following driving conditions:

- Repeated short trips of less than 5 miles (8 km).
- Repeated short trips of less than 10 miles (16 km) with outside temperatures remaining below freezing.
- Operating in hot weather in stop-and-go "rush hour" traffic.
- Extensive idling and/or low speed driving for long distances, such as police, taxi or door-to-door delivery use.
- Driving in dusty conditions.
- Driving on rough, muddy, or salt spread roads.
- Towing a trailer, using a camper or a car-top carrier.

## SCHEDULE 2

Follow Periodic Maintenance Schedule 2 if none of the driving conditions shown in Schedule 1 apply to your driving habits.

GI

MA

EM

LC

EC

FE

AT

PD

FA

RA

BR

ST

RS

BT

HA

EL

IDX

# PERIODIC MAINTENANCE

## Schedule 1

Abbreviations: R = Replace I = Inspect. Correct or replace as necessary. [ ]: Perform service at the mileage intervals only

MAINTENANCE OPERATION	Perform at number of miles, kilometers or months, whichever comes first.	Miles x 1,000 (km x 1,000) Months	MAINTENANCE INTERVAL																Reference page
			3.75	7.5	11.25	15	18.75	22.5	26.25	30	33.75	37.5	41.25	45	48.75	52.5	56.25	60	
			(6)	(12)	(18)	(24)	(30)	(36)	(42)	(48)	(54)	(60)	(66)	(72)	(78)	(84)	(90)	(96)	
			3	6	9	12	15	18	21	24	27	30	33	36	39	42	45	48	

### EMISSION CONTROL SYSTEM MAINTENANCE

<b>Service "A"</b>																				
Engine oil			R	R	R	R	R	R	R	R	R	R	R	R	R	R	R	R	MA-13	
Engine oil filter (Use part No. 15208-60U00 or equivalent)			R	R	R	R	R	R	R	R	R	R	R	R	R	R	R	R	MA-14	
<b>Service "E"</b>																				
Air cleaner filter	See NOTE (1)																		[R]	MA-13
<b>Service "F"</b>																				
Vapor lines																			I*	MA-15
Fuel lines																			I*	MA-12
Fuel filter	See NOTE (2)*																			MA-12
<b>Service "G"</b>																				
Drive belts	See NOTE (3)																		I*	MA-10
<b>Service "J"</b>																				
Engine coolant	See NOTE (4)																		R*	MA-11
<b>Service "H"</b>																				
Spark plugs (PLATINUM-TIPPED type)																			[R]	MA-14

### CHASSIS AND BODY MAINTENANCE

<b>Service "B"</b>																				
Brake pads & discs																				MA-18
Steering gear & linkage, axle & suspension parts																				MA-19, FA-5, RA-5
Steering linkage ball joints & front suspension ball joints																				MA-19, FA-5
Exhaust system																				MA-16
<b>Service "D"</b>																				
Brake lines & cables																				MA-18
Automatic transmission oil & differential gear oil	See NOTE (5)																			MA-16
<b>Service "J"</b>																				
Air bag system	See NOTE (6)																			RS-7

- NOTE:**
- (1) If operating mainly in dusty conditions, more frequent maintenance may be required.
  - (2) If vehicle is operated under extremely adverse weather conditions or in areas where ambient temperatures are either extremely low or extremely high, the filters might become clogged. In such an event, replace them immediately.
  - (3) After 60,000 miles (96,000 km) or 48 months, inspect every 15,000 miles (24,000 km) or 12 months.
  - (4) After 60,000 miles (96,000 km) or 48 months, replace every 30,000 miles (48,000 km) or 24 months.
  - (5) If towing a trailer, using a camper or a car-top carrier, or driving on rough or muddy roads, change (not just inspect) oil at every 30,000 miles (48,000 km) or 24 months.
  - (6) Inspect the air bag system 10 years after the date of manufacture noted on the FMVSS certification label.
- \* Maintenance items and intervals with "\*" are recommended by INFINITI for reliable vehicle operation. The owner need not perform such maintenance in order to maintain the emission warranty or manufacturer recall liability. Other maintenance items and intervals are required.

# PERIODIC MAINTENANCE

## Schedule 2

Abbreviations: R = Replace I = Inspect. Correct or replace as necessary. [ ]: Perform service at the mileage intervals only

Perform at number of miles, kilometers or months, whichever comes first.	Miles x 1,000 (km x 1,000) Months	MAINTENANCE INTERVAL								Reference page
		7.5	15	22.5	30	37.5	45	52.5	60	
		(12)	(24)	(36)	(48)	(60)	(72)	(84)	(96)	
		6	12	18	24	30	36	42	48	

### EMISSION CONTROL SYSTEM MAINTENANCE

Service "A"											
Engine oil		R	R	R	R	R	R	R	R	R	MA-13
Engine oil filters (Use Part No. 15208-60U00 or equivalent)		R	R	R	R	R	R	R	R	R	MA-14
Service "E"											
Air cleaner filter						[R]				[R]	MA-13
Service "F"											
Vapor lines						I*				I*	MA-15
Fuel lines						I*				I*	MA-12
Fuel filter	See NOTE (1)*										MA-12
Service "G"											
Drive belts	See NOTE (2)									I*	MA-10
Service "J"											
Engine coolant	See NOTE (3)									R*	MA-11
Service "H"											
Spark plugs (PLATINUM-TIPPED Type)										[R]	MA-14

### CHASSIS AND BODY MAINTENANCE

Service "D"											
Brake lines & cables			I			I				I	MA-18
Brake pads & discs			I			I				I	MA-18
Automatic transmission oil & differential gear oil			I			I				I	MA-16
Exhaust system						I				I	MA-16
Service "F"											
Steering gear linkage axle & suspension parts						I				I	MA-19, FA-5, RA-5
Service "J"											
Air bag system	See NOTE (4)										RS-7

**NOTE: (1) If vehicle is operated under extremely adverse weather conditions or in areas where ambient temperatures are either extremely low or extremely high, the filters might become clogged. In such an event, replace them immediately.**

**(2) After 60,000 miles (96,000 km) or 48 months, inspect every 15,000 miles (24,000 km) or 12 months.**

**(3) After 60,000 miles (96,000 km) or 48 months, replace every 30,000 miles (48,000 km) or 24 months.**

**(4) Inspect the air bag system 10 years after the date of manufacture noted on the FMVSS certification label.**

\* Maintenance items and intervals with "\*" are recommended by INFINITI for reliable vehicle operation. The owner need not perform such maintenance in order to maintain the emission warranty or manufacturer recall liability. Other maintenance items and intervals are required.

# RECOMMENDED FLUIDS AND LUBRICANTS

## Fluids and Lubricants

	Capacity (Approximate)			Recommended fluids and lubricants
	US measure	Imp measure	Liter	
Engine oil (Refill)				
With oil filter	6-3/8 qt	5-1/4 qt	6.0	● API SG or SH and Energy Conserving II*2
Without oil filter	5-7/8 qt	4-7/8 qt	5.6	● API Certification Mark*2
Cooling system (With reservoir)	10-7/8 qt	9-1/8 qt	10.3	Anti-freeze coolant (Ethylene glycol base)
Differential gear oil	2-3/4 pt	2-1/4 pt	1.3	API GL-5*2
Automatic transmission fluid	11-1/8 qt	9-1/4 qt	10.5	Nissan Matic "D" (Continental U.S. and Alaska) or Genuine Nissan Automatic Transmission Fluid (Canada)*1
Power steering fluid	—	—	—	Type DEXRON™ II or equivalent
Brake and TCS fluid	—	—	—	Genuine Brake Fluid*3 or equivalent DOT 3 (US FMVSS No. 116)
Multi-purpose grease	—	—	—	NLGI No. 2 (Lithium soap base)

\*1: Dexron® III/Mercon® or equivalent may also be used. Outside the continental United States and Alaska contact an INFINITI dealership for more information regarding suitable fluids, including recommended brand(s) of Dexron® III/Mercon® or Dexron® IIE/Mercon® Automatic Transmission Fluid.

\*2: For further details, see "SAE Viscosity Number".

\*3: For more information regarding suitable fluids, contact an INFINITI dealership.

## SAE Viscosity Number

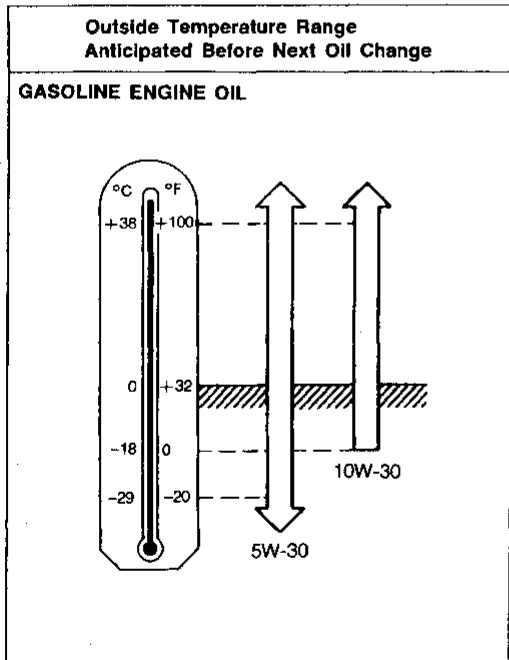

SAE 5W-30 viscosity oil is preferred for all temperatures. SAE 10W-30 viscosity oil may be used if the ambient temperature is above  $-18^{\circ}\text{C}$  ( $0^{\circ}\text{F}$ ).

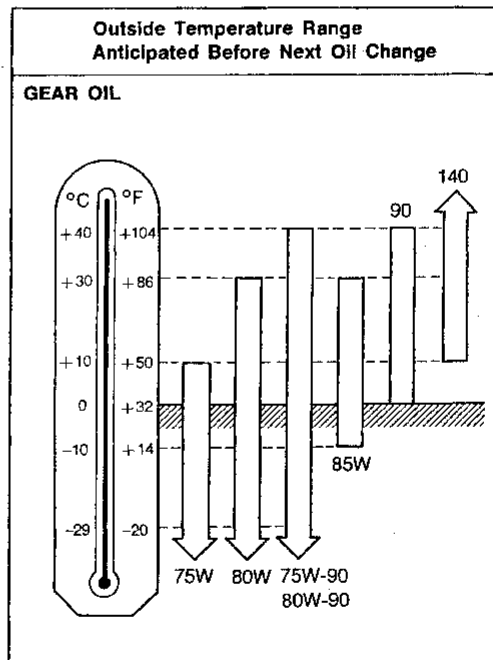

80W-90 for differential gear is preferable for ambient temperatures below  $40^{\circ}\text{C}$  ( $104^{\circ}\text{F}$ ).



**Anti-freeze Coolant Mixture Ratio**

The engine cooling system is filled at the factory with a high-quality, year-round, anti-freeze coolant solution. The anti-freeze solution contains rust and corrosion inhibitors. Therefore, additional cooling system additives are not necessary.

**CAUTION:**

**When adding or replacing coolant, be sure to use only an ethylene glycol anti-freeze with the proper mixture ratio. See the following examples:**

Outside temperature down to		Anti- freeze	Soft water
°C	°F		
-15	5	30%	70%
-35	-30	50%	50%

**The use of other types of coolant solutions may damage your cooling system.**

GI

**MA**

EM

LC

EC

FE

AT

PD

FA

RA

BR

ST

RS

BT

HA

EL

IDX

# ENGINE MAINTENANCE

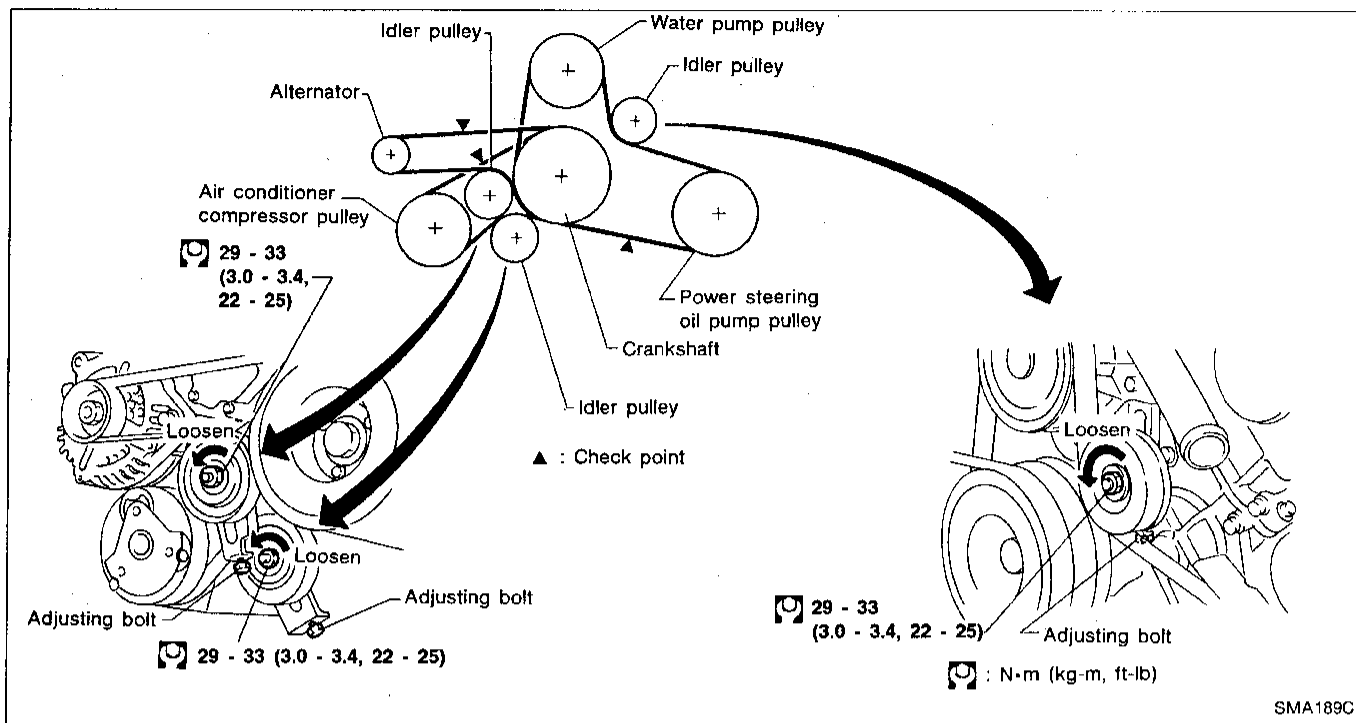

## Checking Drive Belts

1. Inspect for cracks, fraying, wear or oil adhesion. If necessary, replace with a new one.
2. Inspect drive belt deflections by pushing on each check point between pulleys as shown above.

**Adjust if belt deflections exceed the limit.**

### Belt deflection:

Unit: mm (in)

	Used belt deflection		Deflection of new belt
	Limit	Deflection after adjustment	
Alternator	14 (0.55)	9 - 10 (0.35 - 0.39)	7.5 - 8.5 (0.295 - 0.335)
Air conditioner compressor	12 (0.47)	8.5 - 9.5 (0.335 - 0.374)	7.5 - 8.5 (0.295 - 0.335)
Power steering oil pump	14 (0.55)	9 - 10 (0.35 - 0.39)	8 - 9 (0.31 - 0.35)
Applied pushing force	98 N (10 kg, 22 lb)		

Inspect drive belt deflections when engine is cold.

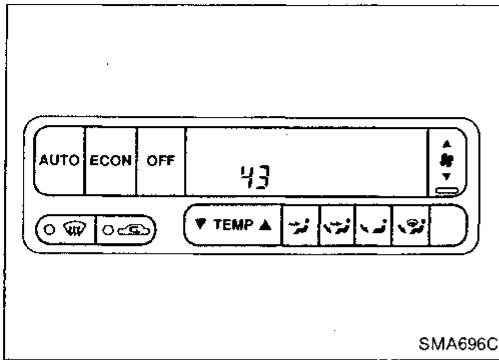

## Changing Engine Coolant

### WARNING:

To avoid being scalded, never change the coolant when the engine is hot.

Wrap a thick cloth around cap and carefully remove the cap. At first, turn the cap a quarter of a turn to release built-up pressure. Then turn the cap all the way.

1. Perform self-diagnosis step 4 of Automatic Air Conditioner system, referring to the following notes. (Refer to "TROUBLE DIAGNOSES" in HA section.)
  - a. Turn ignition switch from "OFF" to "ON".
  - b. Within 10 seconds after ignition switch is turned "ON", press switch for at least 5 seconds.
  - c. Press (HOT) switch 3 times.
  - d. Press (DEF) switch 2 times.
  - e. Confirm indication of the A/C display shown at left.
  - f. Wait 10 seconds before turning ignition switch off.

This step is necessary to allow heater cock to open wide.

### CAUTION:

Do not open the radiator cap while changing engine coolant. Fill the radiator only from the filler cap above radiator upper hose with radiator cap closed.

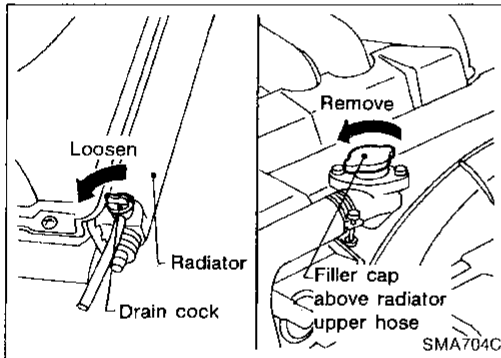

2. Open drain cock at the bottom of radiator, and remove filler cap above radiator upper hose.

● Be careful not to allow coolant to contact drive belts.

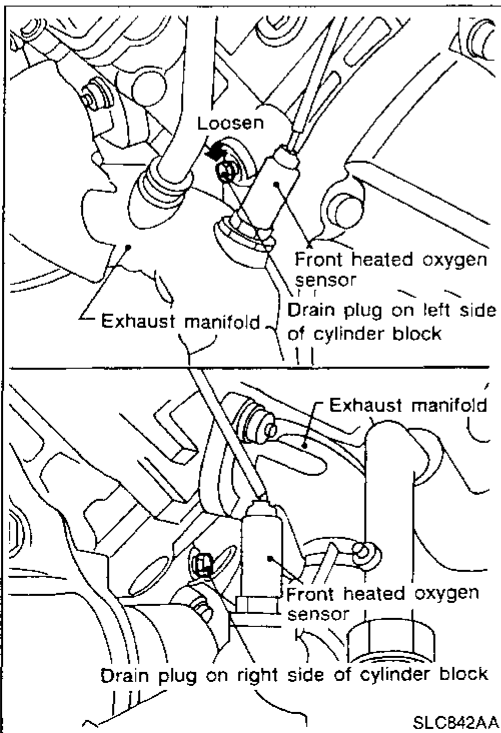

3. Open drain plugs on both sides of cylinder block.
  4. Close drain cock and tighten drain plug securely.
  5. Fill radiator with water.
  6. Perform self-diagnosis step 4 of Automatic Air Conditioner system, referring to the following notes. (Refer to "TROUBLE DIAGNOSES" in HA section.)
    - a. Turn ignition switch from "OFF" to "START".
    - b. Within 10 seconds after starting engine, press switch for at least 5 seconds.
    - c. Press (HOT) switch 3 times.
    - d. Press (DEF) switch 2 times.
    - e. Confirm indication of the A/C display shown at left above.
    - f. Wait 10 seconds and warm up engine sufficiently.

This step is necessary to allow heater water cock to open wide.
  7. Stop engine and wait until it cools down.
  8. Repeat step 2 through step 7 until clear water begins to drain from radiator.
  9. Drain water.
- Apply sealant to the thread of drain plug.
- : 15 - 25 N·m  
(1.5 - 2.5 kg-m, 11 - 18 ft-lb)

## ENGINE MAINTENANCE

### Changing Engine Coolant (Cont'd)

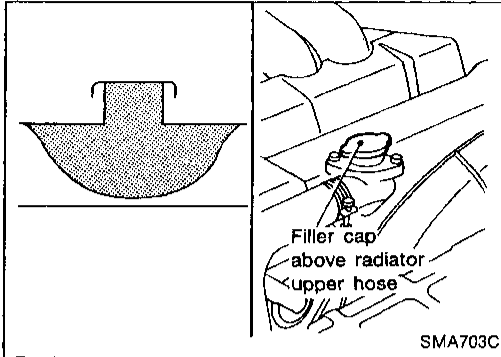

- Fill radiator with coolant up to specified level. Follow instructions attached to anti-freeze container for mixing ratio of anti-freeze to water.

**Coolant capacity (With reservoir tank):**  
10.3 l (10-7/8 US qt, 9-1/8 Imp qt)

**Reservoir tank:**  
0.7 l (3/4 US qt, 5/8 Imp qt)

**Pour coolant through coolant filler neck slowly to allow air in system to escape.**

**Regarding coolant mixture ratio, refer to MA-9.**

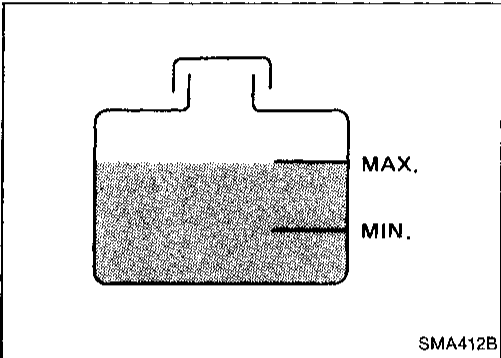

- Remove reservoir tank, drain coolant, then clean reservoir tank.
- Fill reservoir tank with coolant up to "MAX" level.
- Repeat step 6.
- Stop engine and cool it down, then add coolant as necessary.

- **Clean excess coolant from engine block.**

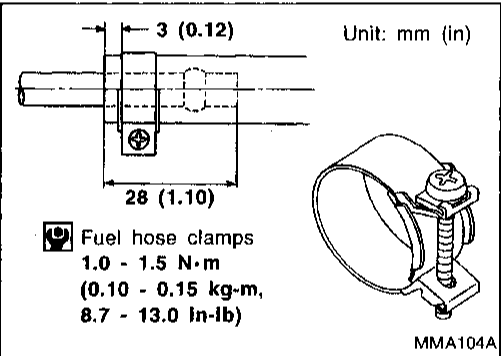

### Checking Fuel Lines

Inspect fuel lines and tank for improper attachment, leaks, cracks, damage, loose connections, chafing and deterioration. If necessary, repair or replace malfunctioning parts.

#### CAUTION:

**Tighten high-pressure rubber hose clamp so that clamp end is 3 mm (0.12 in) from hose end.**

**Tightening torque specifications are the same for all rubber hose clamps.**

**Ensure that screw does not contact adjacent parts.**

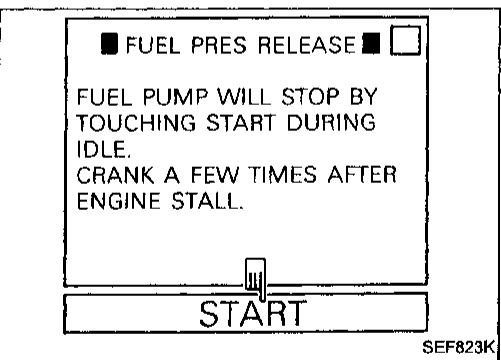

### Changing Fuel Filter

#### WARNING:

**Before removing fuel filter, release fuel pressure from fuel line to eliminate danger.**

- Perform "FUEL PRESSURE RELEASE" in "WORK SUPPORT" mode and release fuel pressure to zero.
- Turn ignition switch off.

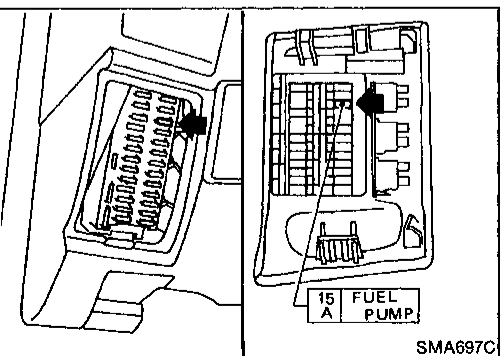

- Remove fuse for fuel pump and start engine.
- After engine stalls, crank engine two or three times to make sure that fuel pressure is released. Then turn ignition switch off and reinstall fuse for fuel pump.

# ENGINE MAINTENANCE

## Changing Fuel Filter (Cont'd)

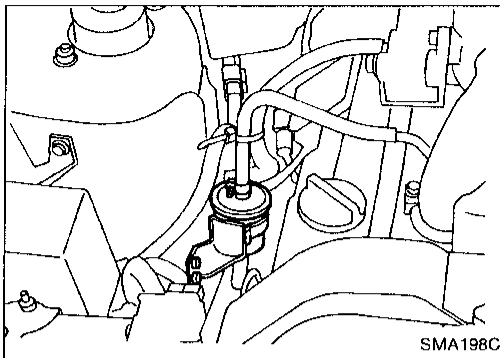

3. Loosen fuel hose clamps.
  4. Replace fuel filter.
- Be careful not to spill fuel over engine compartment. Place a shop towel to absorb fuel.
  - Use a high-pressure type fuel filter. Do not use a synthetic resinous fuel filter.
  - When tightening fuel hose clamps, refer to "Checking Fuel Lines".

GI

MA

EM

## Changing Air Cleaner Filter

The viscous paper type filter does not need cleaning between renewals.

LC

EC

FE

AT

PD

FA

RA

BR

ST

RS

BT

HA

EL

IDX

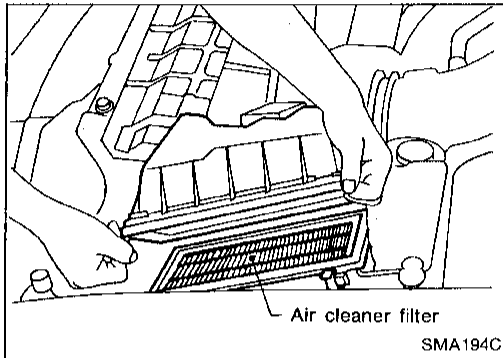

## Changing Engine Oil

### WARNING:

- Be careful not to burn yourself, as the engine oil is hot.
- Prolonged and repeated contact with used engine oil may cause skin cancer; try to avoid direct skin contact with used oil. If skin contact is made, wash thoroughly with soap or hand cleaner as soon as possible.

1. Warm up engine, and check for oil leakage from engine components.
2. Remove drain plug and oil filler cap.
3. Drain oil and refill with new engine oil.

### Oil specifications and viscosity:

- API SG or SH and Energy Conserving II
- API Certification Mark
- See "RECOMMENDED FLUIDS AND LUBRICANTS" (MA-8).

### Refill oil capacity (Approximately):

- With oil filter 6.0 l (6-3/8 US qt, 5-1/4 Imp qt)
- Without oil filter 5.6 l (5-7/8 US qt, 4-7/8 Imp qt)

### CAUTION:

- Be sure to clean drain plug and install with new washer.  
Drain plug:  
⌘: 29 - 39 N·m (3.0 - 4.0 kg·m, 22 - 29 ft·lb)
  - The refill capacity changes depending on the oil temperature and drain time. Use these values as a reference and be sure to check with dipstick when changing oil.
  - Make sure direction of oil level gauge is correct before checking oil level.
4. Check oil level.
  5. Start engine and check area around drain plug and oil filter for oil leakage.
  6. Run engine for a few minutes, then turn it off. After several minutes, check oil level.

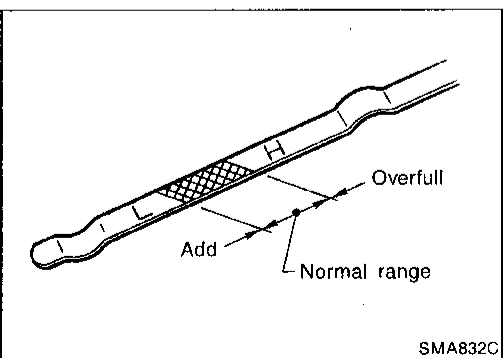
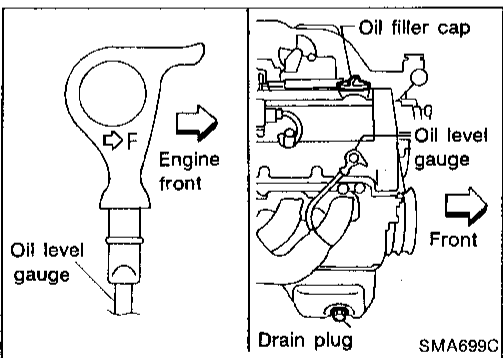
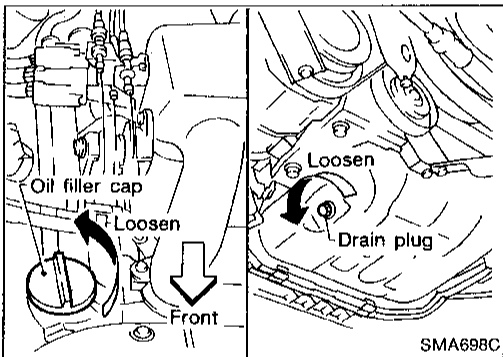

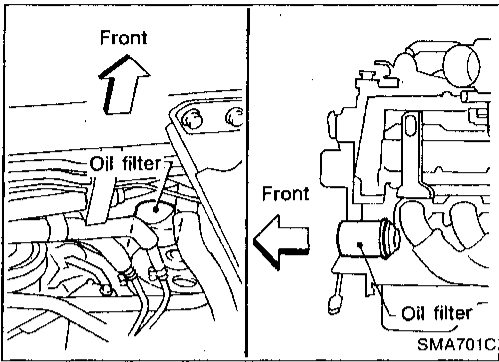

## Changing Oil Filter

1. Remove oil filter from underneath the engine compartment with a suitable tool.

### WARNING:

Be careful not to burn yourself, as the engine and the engine oil are hot.

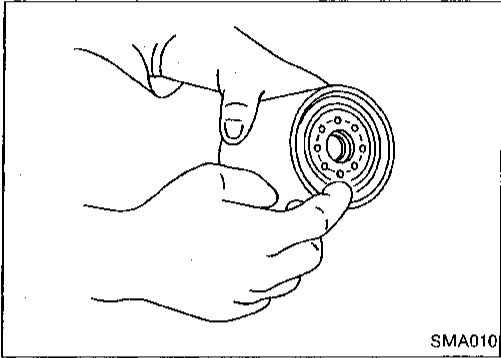

2. Clean oil filter mounting surface on cylinder block. Coat rubber seal of new oil filter with engine oil.

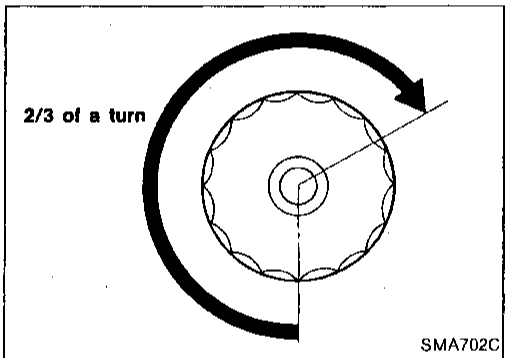

3. Screw in the oil filter until a slight resistance is felt, then tighten additionally more than 2/3 turn.

4. Add engine oil.

Refer to Changing Engine Oil (MA-13).

- Clean excess oil from engine block.

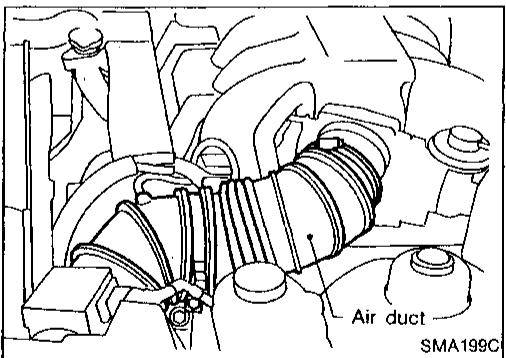

## Changing Spark Plugs

1. Remove air duct (left bank only).

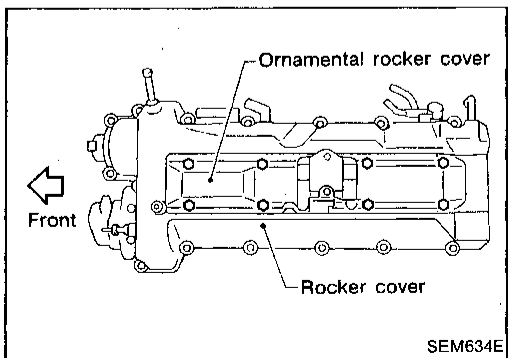

2. Remove ornament cover.

# ENGINE MAINTENANCE

## Changing Spark Plugs (Cont'd)

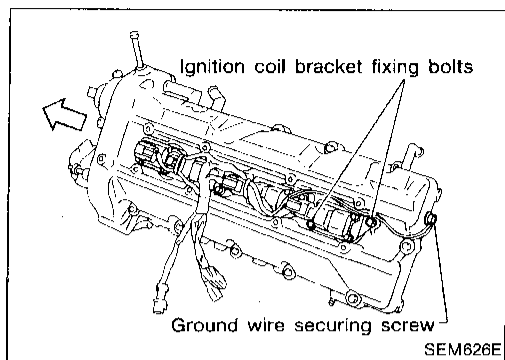

3. Disconnect ignition coil harness connector.
4. Remove ignition coil bracket fixing bolts and pull out this bracket with ignition coils.

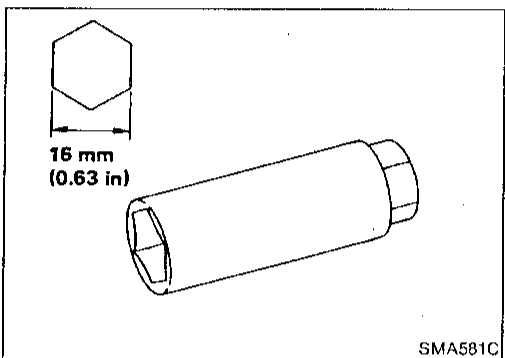

5. Remove spark plugs with suitable spark plug wrench.

### Spark plug (Platinum-tipped type):

Make	NGK
Standard type	PFR5G-11
Cold type	PFR6G-11
	PFR7G-11

: 20 - 29 N·m  
(2.0 - 3.0 kg-m, 14 - 22 ft-lb)

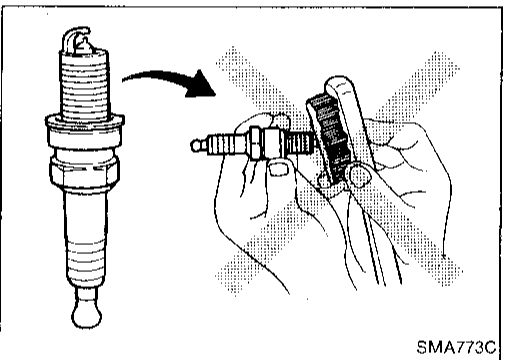

- Do not use a wire brush for cleaning.
- If plug tip is covered with carbon, spark plug cleaner may be used.

Cleaner air pressure:

Less than 588 kPa (6 kg/cm<sup>2</sup>, 85 psi)

Cleaning time:

Less than 20 seconds

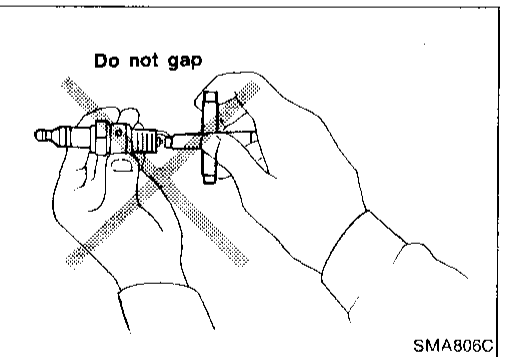

- Checking and adjusting plug gap is not required between change intervals.

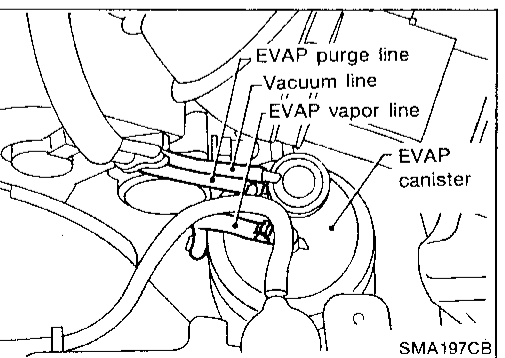

## Checking EVAP Vapor Purge Lines

1. Visually inspect EVAP vapor purge lines for improper attachment, cracks, damage, loose connections, chafing or deterioration.
2. Inspect vacuum relief valve of fuel tank filler cap for clogging, sticking, etc.

Refer to EVAPORATIVE EMISSION SYSTEM in EC section.

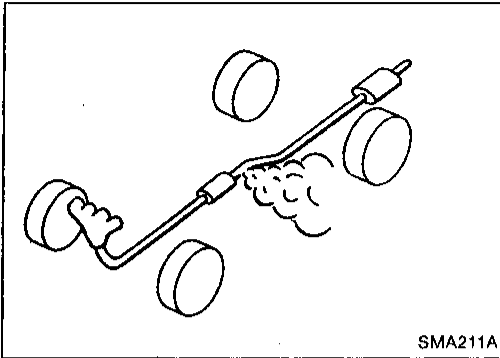

## Checking Exhaust System

Check exhaust pipes, muffler and mounting for improper attachment and for leaks, cracks, damage, loose connections, chafing and deterioration.

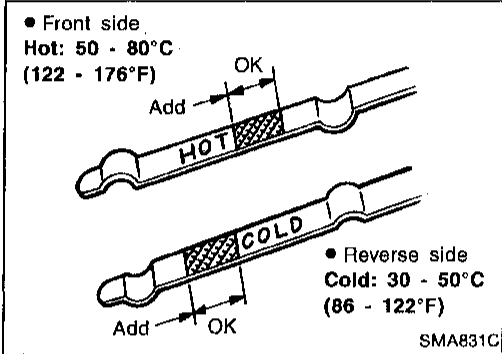

## Checking A/T Fluid

1. Warm up engine.
2. Check for fluid leakage.
3. Before driving, fluid level can be checked at fluid temperatures of 30 to 50°C (86 to 122°F) using "COLD" range on dipstick.
  - a. Park vehicle on level surface and set parking brake.
  - b. Start engine and move selector lever through each gear position. Leave selector lever in "P" position.
  - c. Check fluid level with engine idling.
  - d. Remove dipstick and wipe clean with lint-free paper.
  - e. Re-insert dipstick into charging pipe as far as it will go.
  - f. Remove dipstick and note reading. If reading is at low side of range, add fluid to the charging pipe.

### Do not overfill.

4. Drive vehicle for approximately 5 minutes in urban areas.
5. Re-check fluid level at fluid temperatures of 50 to 80°C (122 to 176°F) using "HOT" range on dipstick.

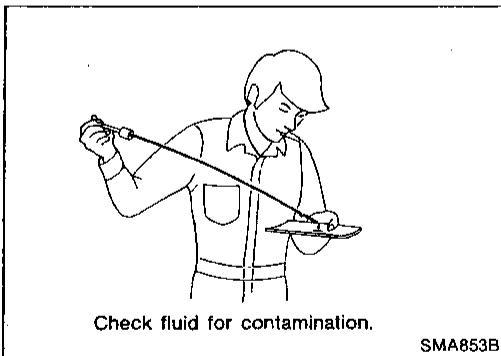

6. Check fluid condition.
  - If fluid is very dark or smells burned, refer to AT section for checking operation of A/T. Flush cooling system after repair of A/T.
  - If A/T fluid contains frictional material (clutches, bands, etc.), replace radiator and flush cooler line using cleaning solvent and compressed air after repair of A/T. Refer to LC section ("Radiator", "ENGINE COOLING SYSTEM").



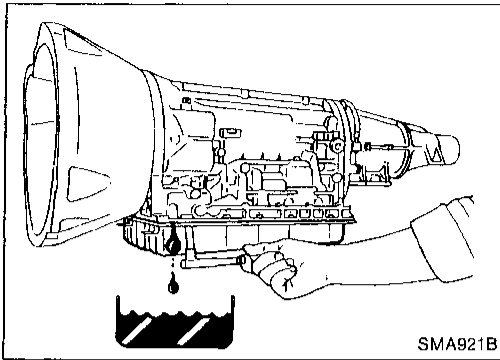

## Changing A/T Fluid

1. Warm up A/T fluid.
2. Stop engine.
3. Drain A/T fluid from drain plug and refill with new A/T fluid. Always refill same volume with drained fluid.

### Fluid grade:

**Nissan Matic "D" (Continental U.S. and Alaska) or Genuine Nissan Automatic Transmission Fluid (Canada)**

Refer to "RECOMMENDED FLUIDS AND LUBRICANTS", MA-8.

### Fluid capacity (With torque converter):

10.5 l (11-1/8 US qt, 9-1/4 Imp qt)

### Drain plug:

: 29 - 39 N·m (3.0 - 4.0 kg-m, 22 - 29 ft-lb)

4. Run engine at idle speed for five minutes.
5. Check fluid level and condition. Refer to "Checking A/T Fluid". If fluid is still dirty, repeat step 2. through 5.

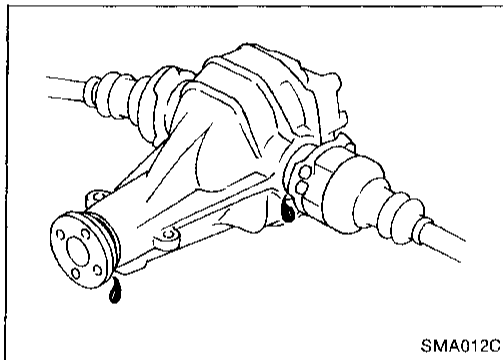

## Checking Differential Gear Oil

1. Check for oil leakage and oil level.

### Filler plug:

: 39 - 59 N·m (4 - 6 kg-m, 29 - 43 ft-lb)

## Changing Differential Gear Oil

1. Drain oil from drain plug and refill with new gear oil.
2. Check oil level.

### Oil grade: API GL-5

### Viscosity:

See "RECOMMENDED FUEL AND LUBRICANTS", MA-8.

### Capacity:

1.3 l (2-3/4 US pt, 2-1/4 Imp pt)

### Drain plug:

: 39 - 59 N·m (4 - 6 kg-m, 29 - 43 ft-lb)

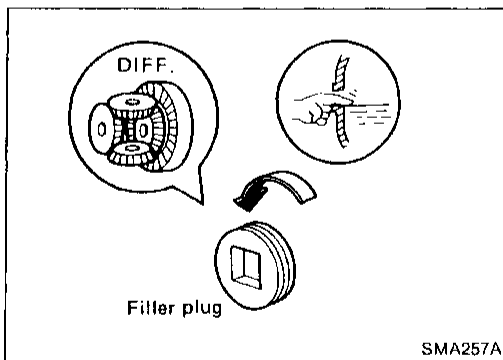

## Balancing Wheels

- Adjust wheel balance using road wheel center.  
**Wheel balance (Maximum allowable unbalance):**  
Refer to "Chassis and Body Maintenance" in SDS. (MA-21)

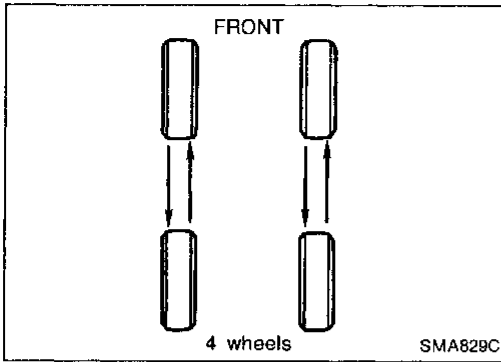

## Tire Rotation

- Do not include the T-type spare tire when rotating the tires.
- Wheel nuts:  
: 98 - 118 N·m (10.0 - 12.0 kg-m, 72 - 87 ft-lb)

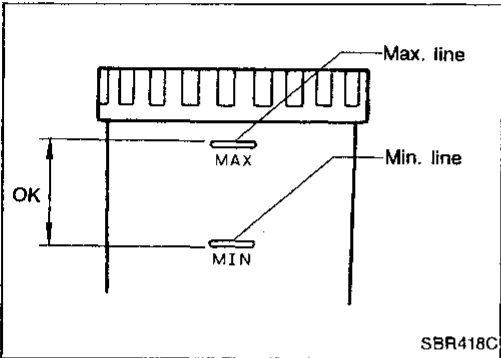

## Checking Brake Fluid Level and Leaks

- If fluid level is extremely low, check brake system for leaks.

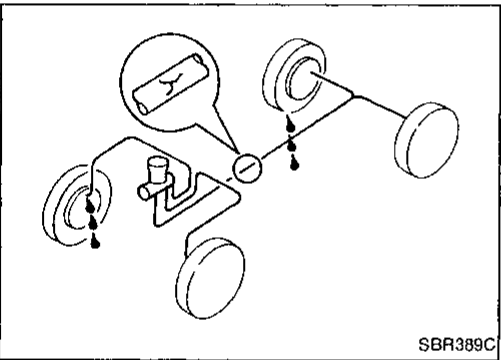

## Checking Brake Lines and Cables

- Check brake fluid lines and parking brake cables for improper attachment and for leaks, chafing, abrasions, deterioration, etc.

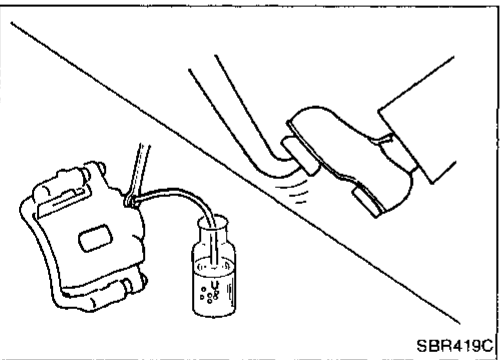

## Changing Brake Fluid

- Drain brake fluid from each air bleeder valve.
  - Refill until new brake fluid comes out from each air bleeder valve.
- Use same procedure as in bleeding hydraulic system to refill brake fluid.  
 Refer to section "CHECK AND ADJUSTMENT" in BR section.
- Refill with recommended brake fluid "DOT 3".
  - Never reuse drained brake fluid.
  - Be careful not to splash brake fluid on painted areas.

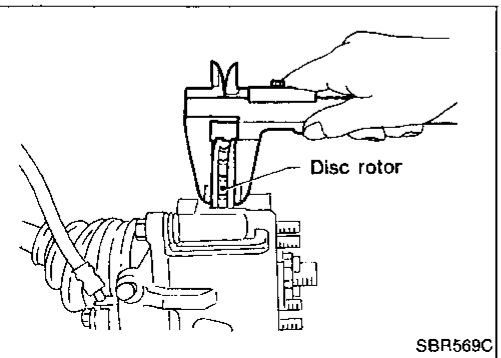

## Checking Disc Brake

### ROTOR

- Check condition and thickness.

	Unit: mm (in)	
	Front	Rear
Standard thickness	28.0 (1.102)	9.0 (0.354)
Minimum thickness	26.0 (1.024)	8.0 (0.315)

# CHASSIS AND BODY MAINTENANCE

## Checking Disc Brake (Cont'd)

### CALIPER

- Check operation and for leakage.

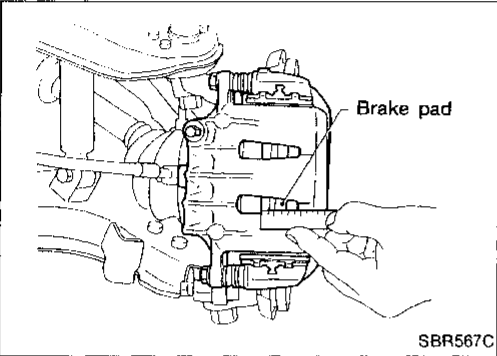
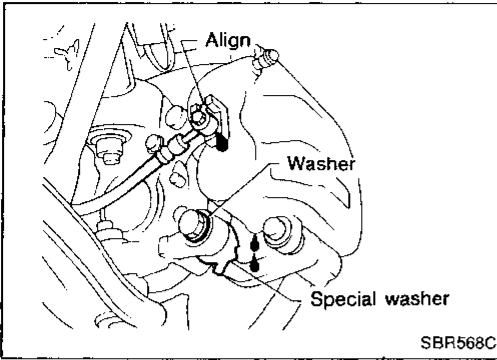

### PAD

- Check pad thickness from inspection hole.
- Check for uneven wear or damage.

	Unit: mm (in)	
	Front	Rear
Standard thickness	9.5 (0.374)	10.0 (0.394)
Minimum thickness	2.0 (0.079)	

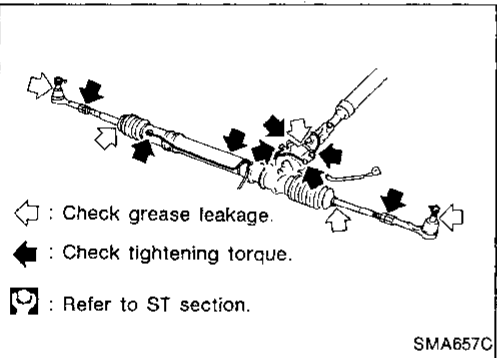

## Checking Steering Gear and Linkage

### STEERING GEAR

- Check gear housing and boots for looseness, damage or grease leakage.
- Check connection with steering column for looseness.

### STEERING LINKAGE

- Check ball joint, dust cover and other component parts for looseness, wear, damage or grease leakage.

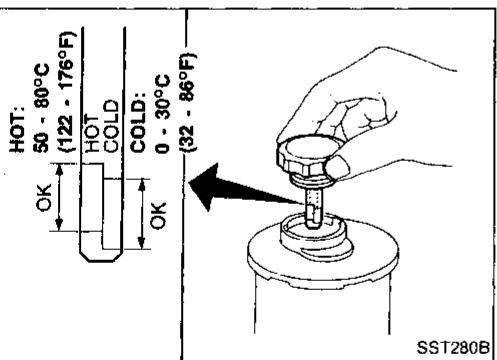

## Checking Power Steering Fluid and Lines

- Check fluid level with engine off.
- Check fluid level with dipstick on reservoir cap. Use "HOT" range at fluid temperatures of 50 to 80°C (122 to 176°F). Use "COLD" range at fluid temperatures of 0 to 30°C (32 to 86°F).

### CAUTION:

- Do not overfill.
- Recommended fluid is Automatic Transmission Fluid type "DEXRON™II" or equivalent.

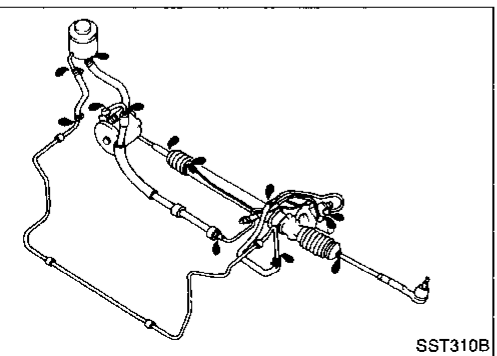

- Check lines for improper attachment, leaks, cracks, damage, loose connections, chafing or deterioration.
- Check rack boots for accumulation of power steering fluid.

## Lubricating Locks, Hinges and Hood Latches

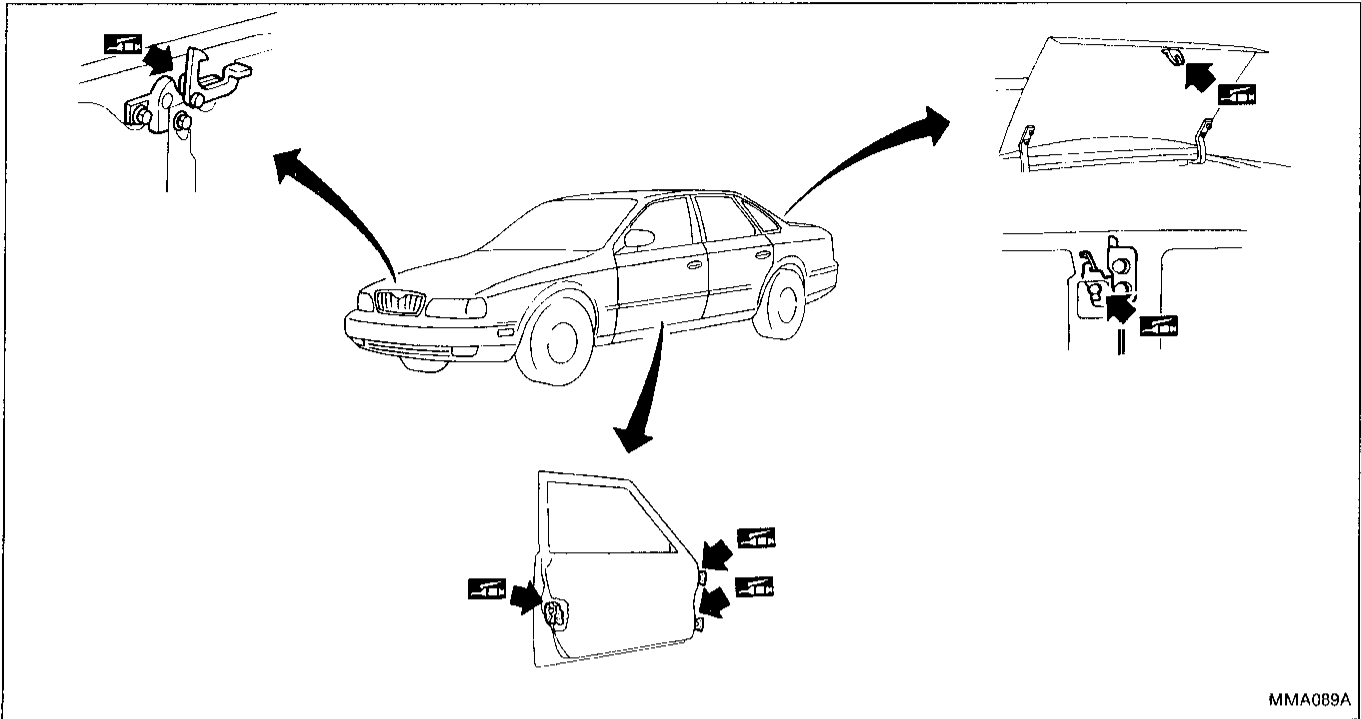

MMA089A

## Checking Seat Belts, Buckles, Retractors, Anchors and Adjusters

### CAUTION:

- After any collision, inspect all seat belt assemblies, including retractors and other attached hardware (i.e. guide rail set). Nissan recommends to replace all seat belt assemblies in use during a collision, unless not damaged and properly operating after minor collision. Also inspect seat belt assemblies not in use during a collision, and replace if damaged or improperly operating.
- If any component of seat belt assembly is questionable, do not repair. Replace as seat belt assembly.
- If webbing is cut, frayed, or damaged, replace belt assembly.
- Never oil tongue and buckle.
- Use a genuine seat belt assembly.

For seat belt pre-tensioner, refer to RS section.

### Anchor bolt

43 - 55 (4.4 - 5.6, 32 - 41)

: N·m (kg·m, ft·lb)

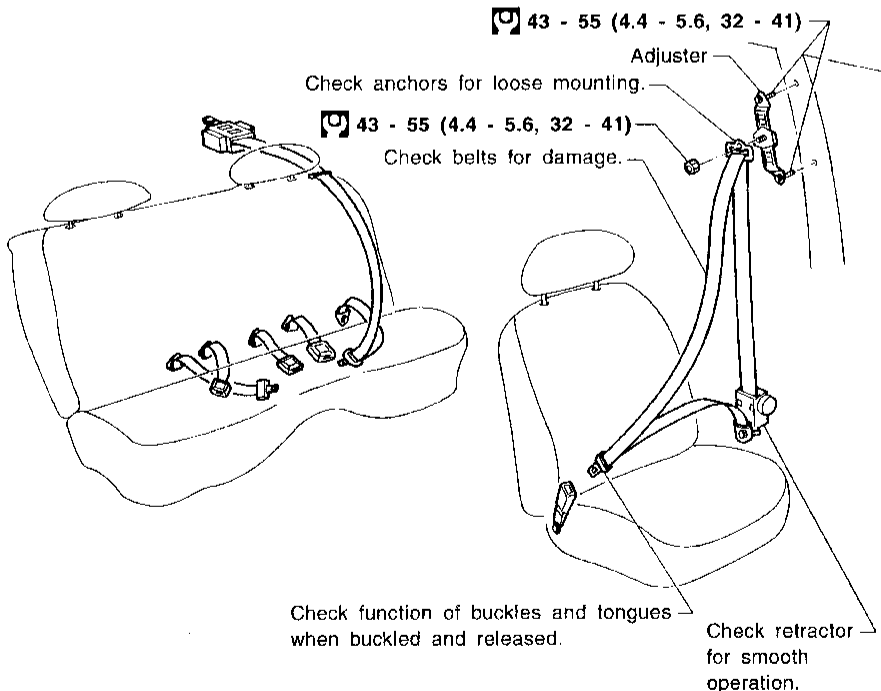

MMA108A

## SERVICE DATA AND SPECIFICATIONS (SDS)

### Engine Maintenance

#### INSPECTION AND ADJUSTMENT

##### Drive belt deflection

Unit: mm (in)

	Used belt deflection		Deflection of new belt
	Limit	Deflection after adjustment	
Alternator	14 (0.55)	9 - 10 (0.35 - 0.39)	7.5 - 8.5 (0.295 - 0.335)
Air conditioner compressor	12 (0.47)	8.5 - 9.5 (0.335 - 0.374)	7.5 - 8.5 (0.295 - 0.335)
Power steering oil pump	14 (0.55)	9 - 10 (0.35 - 0.39)	8 - 9 (0.31 - 0.35)
Applied pushing force	98 N (10 kg, 22 lb)		

##### Spark plug

Standard type	PFR5G-11
Cold type	PFR6G-11 PFR7G-11

### Chassis and Body Maintenance

#### INSPECTION AND ADJUSTMENT

##### Wheel balance

Maximum allowable unbalance	Dynamic (at rim flange)	10 (0.35) (One side)
	Static	20 (0.71)

GI

MA

EM

LC

EC

FE

AT

PD

FA

RA

BR

ST

RS

BT

HA

EL

IDX