

ENGINE LUBRICATION & COOLING SYSTEMS

SECTION **LC**

GI

MA

EM

LC

EC

FE

AT

PD

EA

RA

BR

ST

RS

BT

HA

EL

IDX

CONTENTS

PRECAUTIONS AND PREPARATION	2	Water Pump.....	9
Liquid Gasket Application Procedure.....	2	Thermostat.....	11
Special Service Tools.....	2	Radiator.....	13
ENGINE LUBRICATION SYSTEM	3	Cooling Fan (Crankshaft driven).....	17
Lubrication Circuit.....	3	Cooling Fan (Motor driven).....	17
Oil Pressure Check.....	4	Overheating Cause Analysis.....	18
Oil Pump.....	5	SERVICE DATA AND SPECIFICATIONS (SDS)	19
ENGINE COOLING SYSTEM	8	Engine Lubrication System.....	19
Cooling Circuit.....	8	Engine Cooling System.....	19
System Check.....	8		

PRECAUTIONS AND PREPARATION

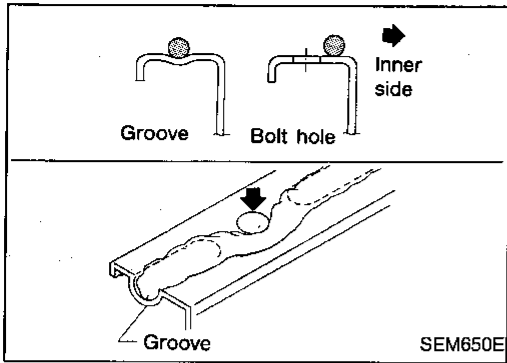

Liquid Gasket Application Procedure

- a. Use a scraper to remove all traces of old liquid gasket from mating surfaces and grooves. Also, completely clean any oil from these areas.
- b. Apply a continuous bead of liquid gasket to mating surfaces. (Use Genuine RTV silicone sealant part No. 999 MP-A7007, Three Bond TB1207D or equivalent.)
 - Be sure liquid gasket is 3.5 to 4.5 mm (0.138 to 0.177 in) wide (for oil pan).
 - Be sure liquid gasket is 2.0 to 3.0 mm (0.079 to 0.118 in) wide (in areas except oil pan).
- c. Apply liquid gasket to inner side as shown at the left.
- d. Assembly should be done within 5 minutes after coating.
- e. Wait 30 minutes before refilling engine oil and coolant.

Special Service Tools

The actual shapes of Kent-Moore tools may differ from those of special service tools illustrated here.

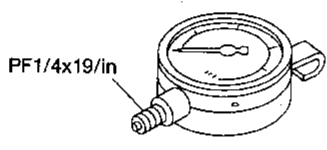
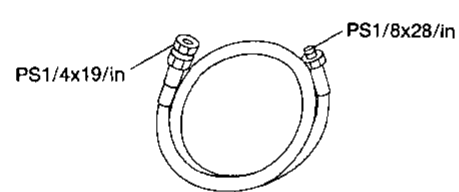
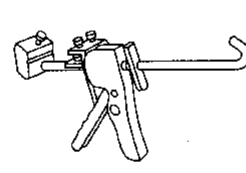
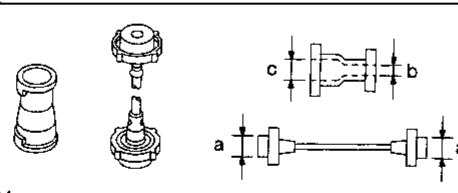
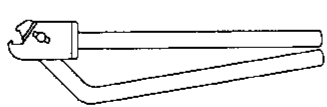
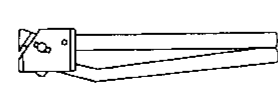
Tool number (Kent-Moore No.) Tool name	Description
ST25051001 (J25695-1) Oil pressure gauge	 Measuring oil pressure Maximum measuring range: 2,452 kPa (25 kg/cm ² , 356 psi)
ST25052000 (J25695-2) Hose	 Adapting oil pressure gauge to cylinder block
WS39930000 (—) Tube presser	 Pressing the tube of liquid gasket
EG17650301 (J33984-A) Radiator cap tester adapter	 Adapting radiator cap tester to radiator filler neck Unit: mm (in) a: 28 (1.10) dia. b: 31.4 (1.236) dia. c: 41.3 (1.626) dia.
KV99103510 (—) Radiator plate pliers A	 Installing radiator upper and lower tanks
KV99103520 (—) Radiator plate pliers B	 Removing radiator upper and lower tanks

ENGINE LUBRICATION SYSTEM

Lubrication Circuit

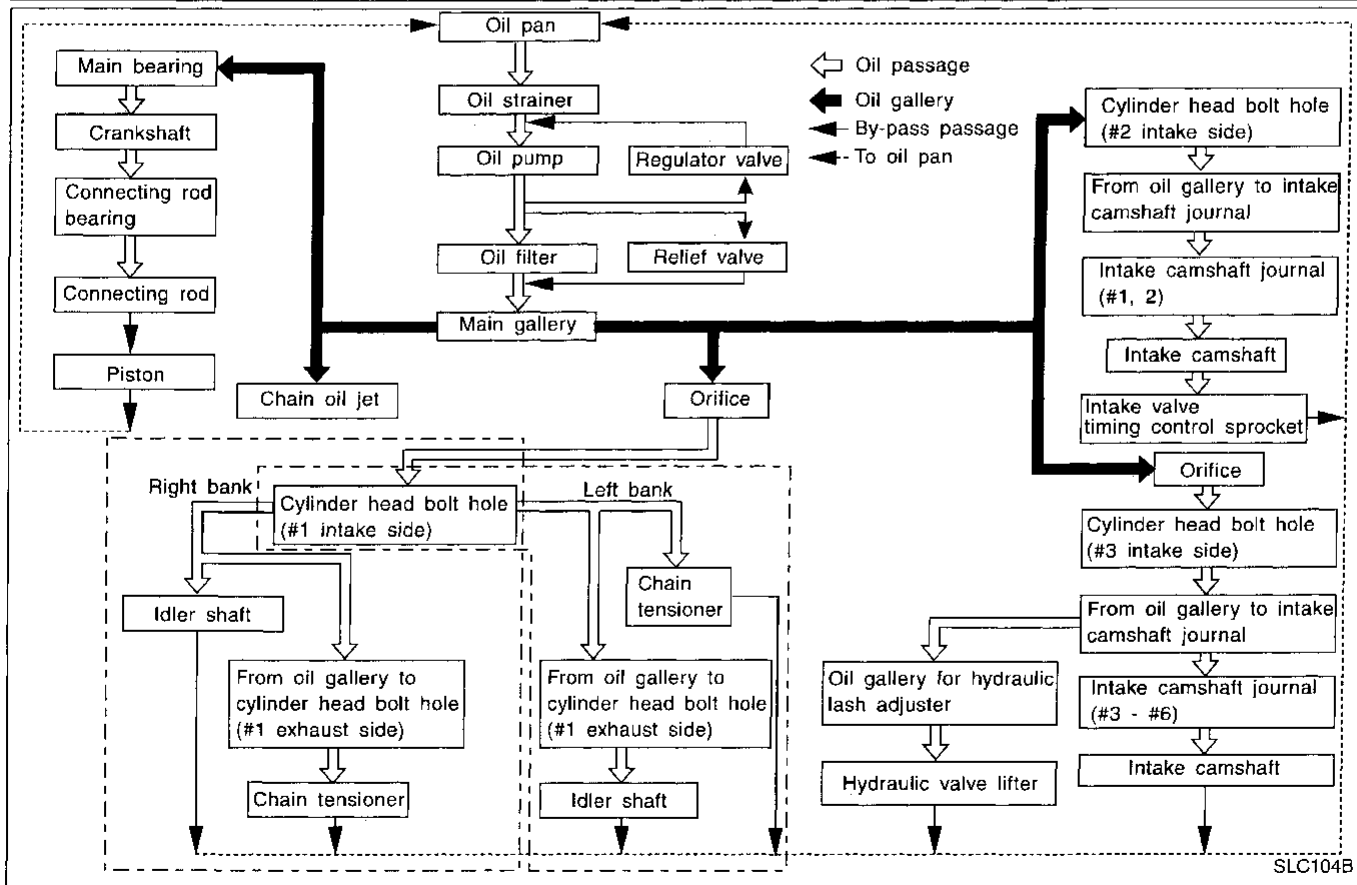
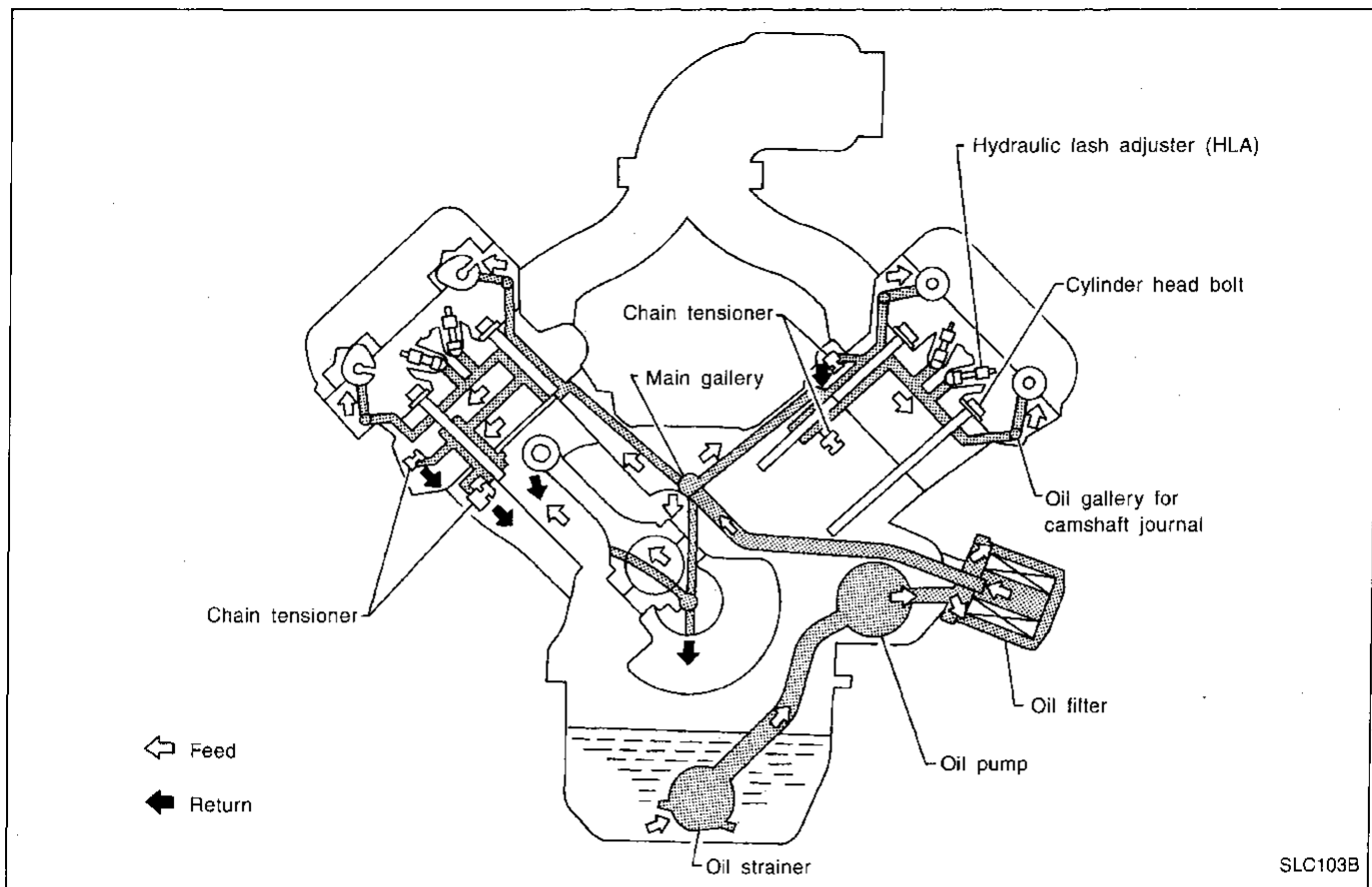

CI
MA
EM
LC
EC
FE
AT
PD
FA
RA
BR
ST
RS
BT
HA
EL
IDX

ENGINE LUBRICATION SYSTEM

Oil Pressure Check

WARNING:

- Be careful not to burn yourself, as the engine and oil may hot.
- Oil pressure check should be done in "Parking position".

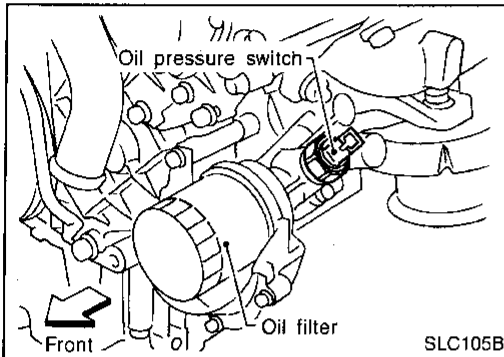

1. Check oil level.
2. Remove oil pressure switch.

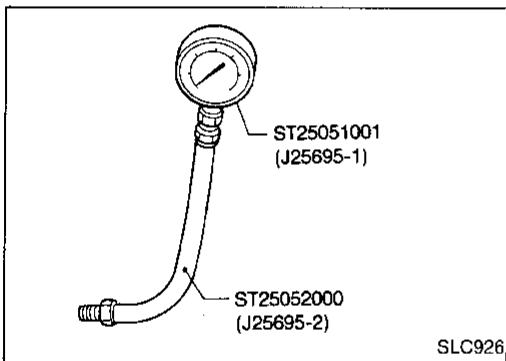

3. Install pressure gauge.
4. Start engine and warm it up to normal operating temperature.
5. Check oil pressure with engine running under no-load.

Engine speed rpm	Approximate discharge pressure kPa (kg/cm ² , psi)
Idle speed	More than 98 (1.0, 14)
3,000	461 - 559 (4.7 - 5.7, 67 - 81)

If difference is extreme, check oil passage and oil pump for oil leaks.

6. Install oil pressure switch with sealant.

Oil Pump

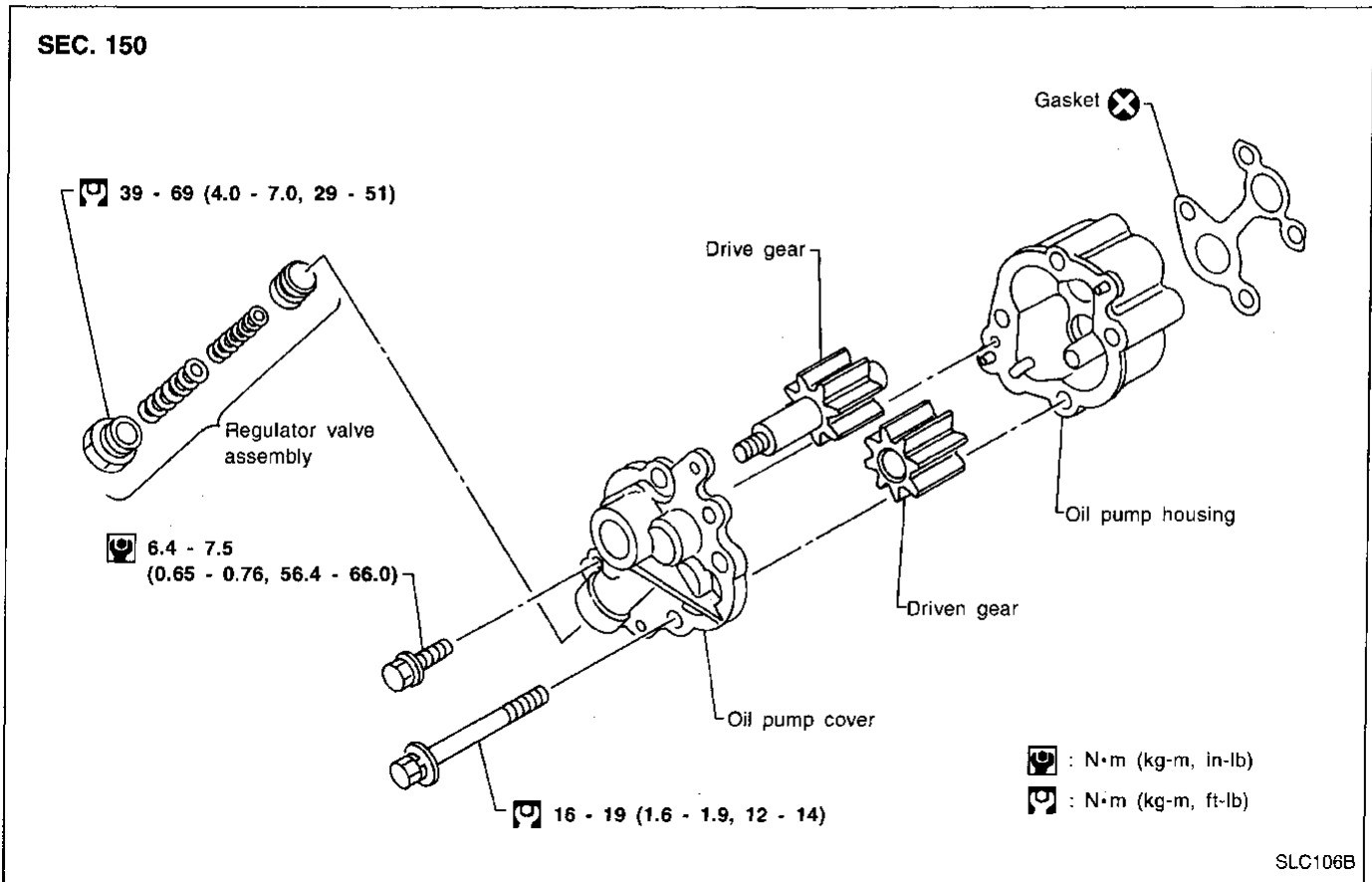

REMOVAL AND INSTALLATION

1. Remove timing chain.
 2. Remove oil pump assembly.
 3. Reinstall any parts removed in reverse order of removal.
- After installing oil pump, make sure drive gear turns smoothly by hand.**

INSPECTION

If it exceeds the limit, replace gear set or entire oil pump assembly.

Standard clearance:

	Unit: mm (in)
Drive shaft to cover and housing clearance Ⓒ	0.024 - 0.069 (0.0009 - 0.0027)
Driven gear to driven shaft clearance Ⓓ	0.025 - 0.064 (0.0010 - 0.0025)
Drive and driven gear to housing axial clearance Ⓔ	0.08 - 0.130 (0.0031 - 0.0051)
Drive and driven gear to housing radial clearance Ⓕ	0.125 - 0.245 (0.0049 - 0.0096)

ENGINE LUBRICATION SYSTEM

Oil Pump (Cont'd)

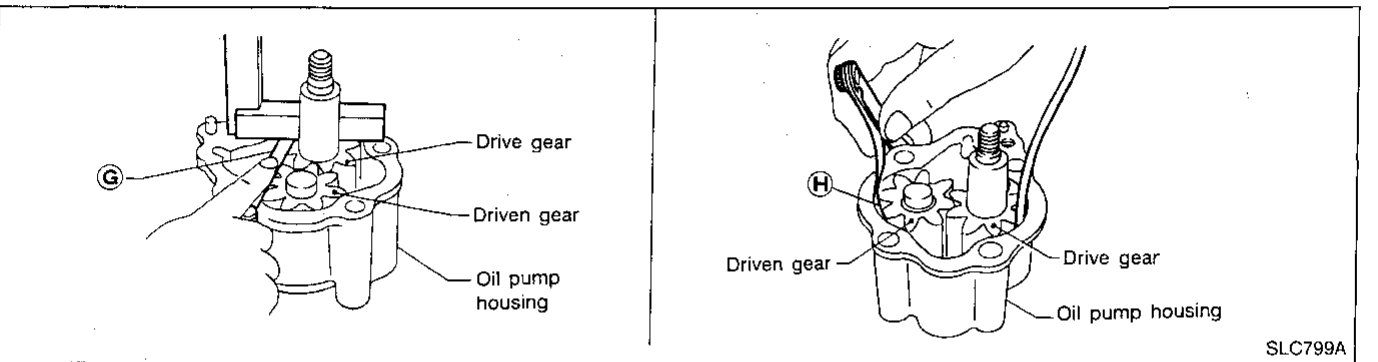
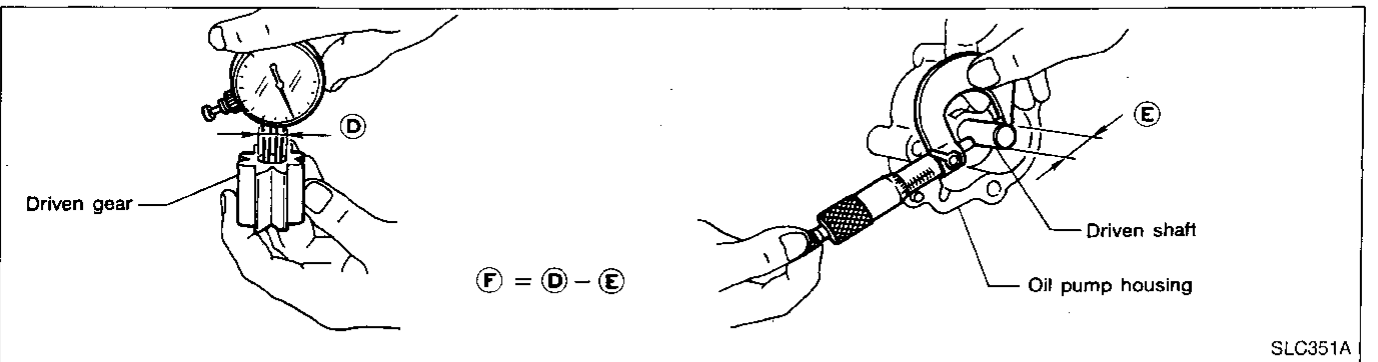
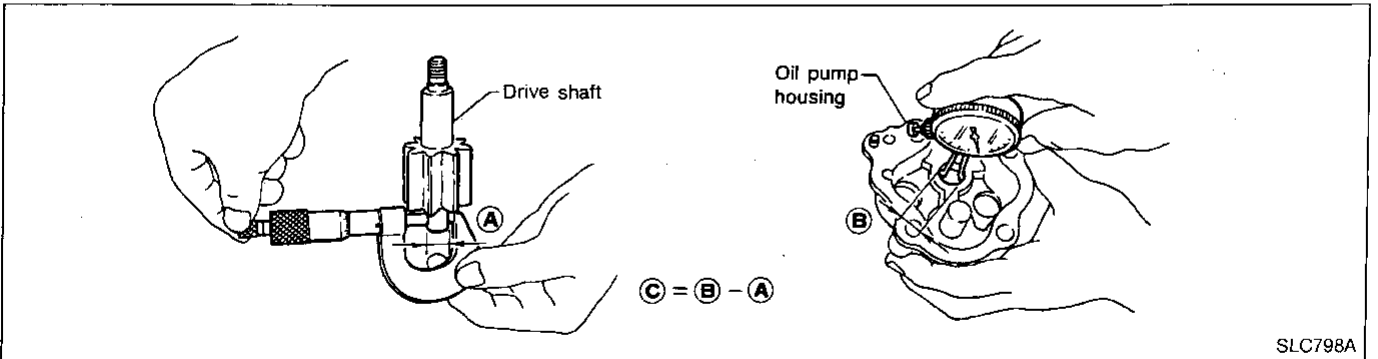
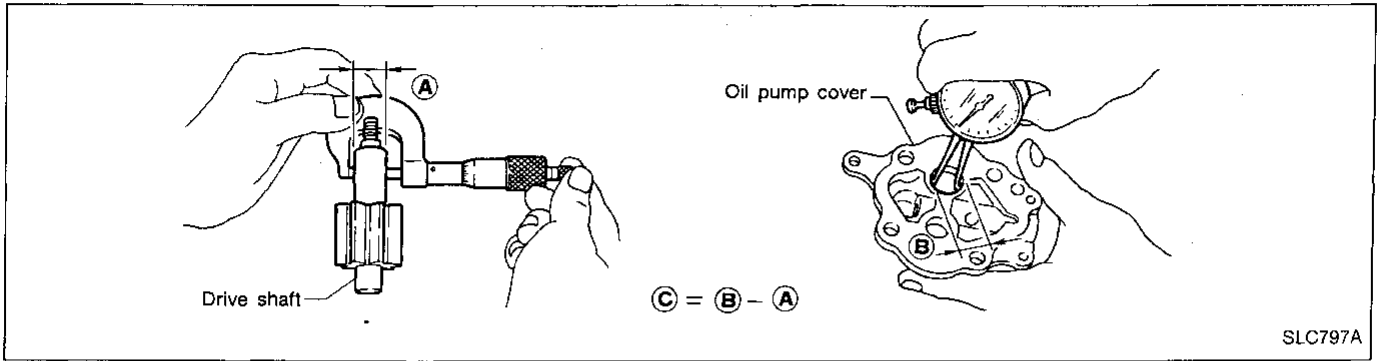

ENGINE LUBRICATION SYSTEM

Oil Pump (Cont'd)

REGULATOR VALVE INSPECTION

1. Visually inspect components for wear and damage.
2. Check oil pressure regulator valve sliding surface and valve spring.
3. Coat regulator valve with engine oil. Check that it falls freely into the valve hole by its own weight.
4. Check regulator valve to oil pump cover clearance.

Standard clearance:

Ⓛ: 0.040 - 0.097 mm (0.0016 - 0.0038 in)

If damaged, replace regulator valve set or oil pump assembly.

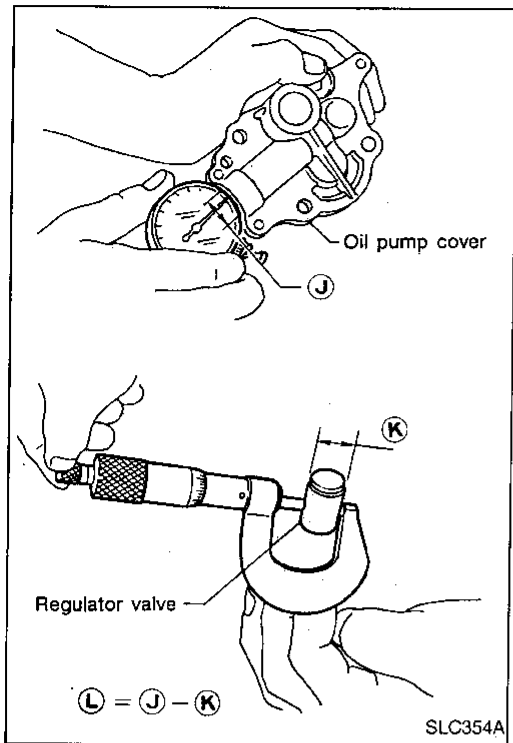

GI

MA

EM

LC

EC

FE

AT

PD

FA

RA

BR

ST

RS

BT

HA

EL

IDX

ENGINE COOLING SYSTEM

Cooling Circuit

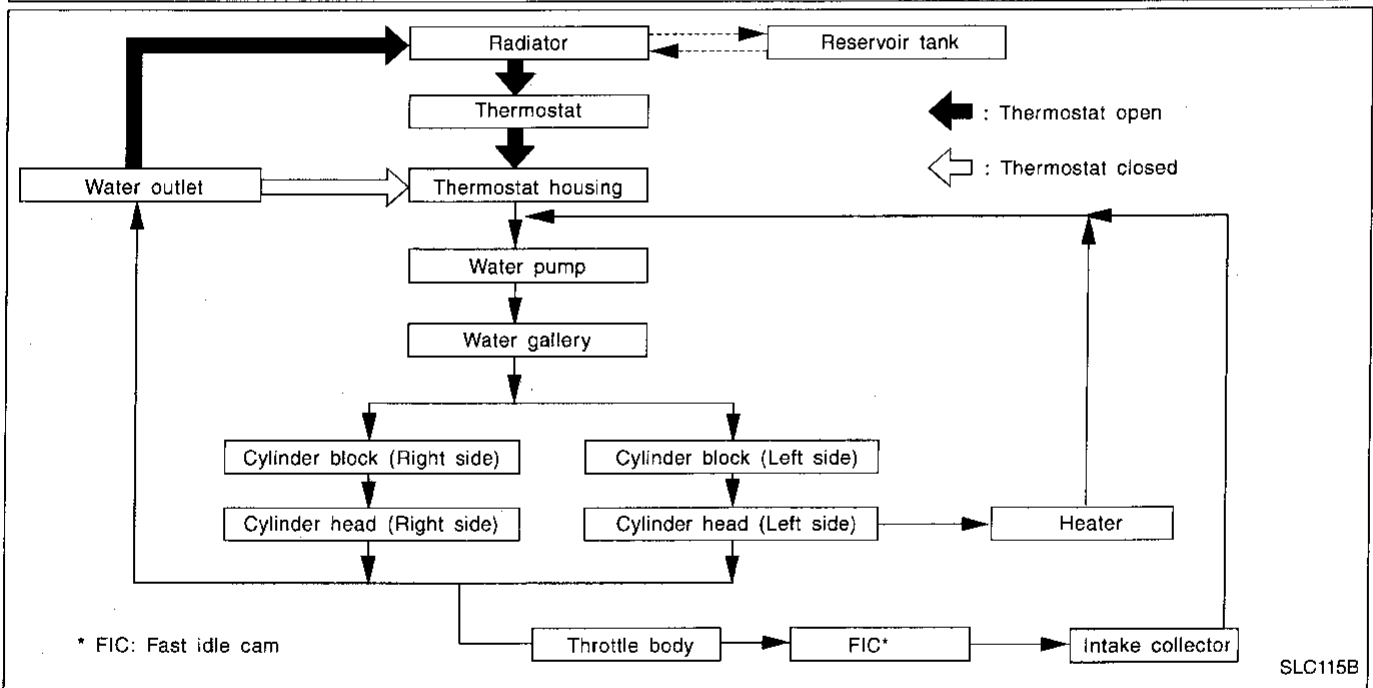
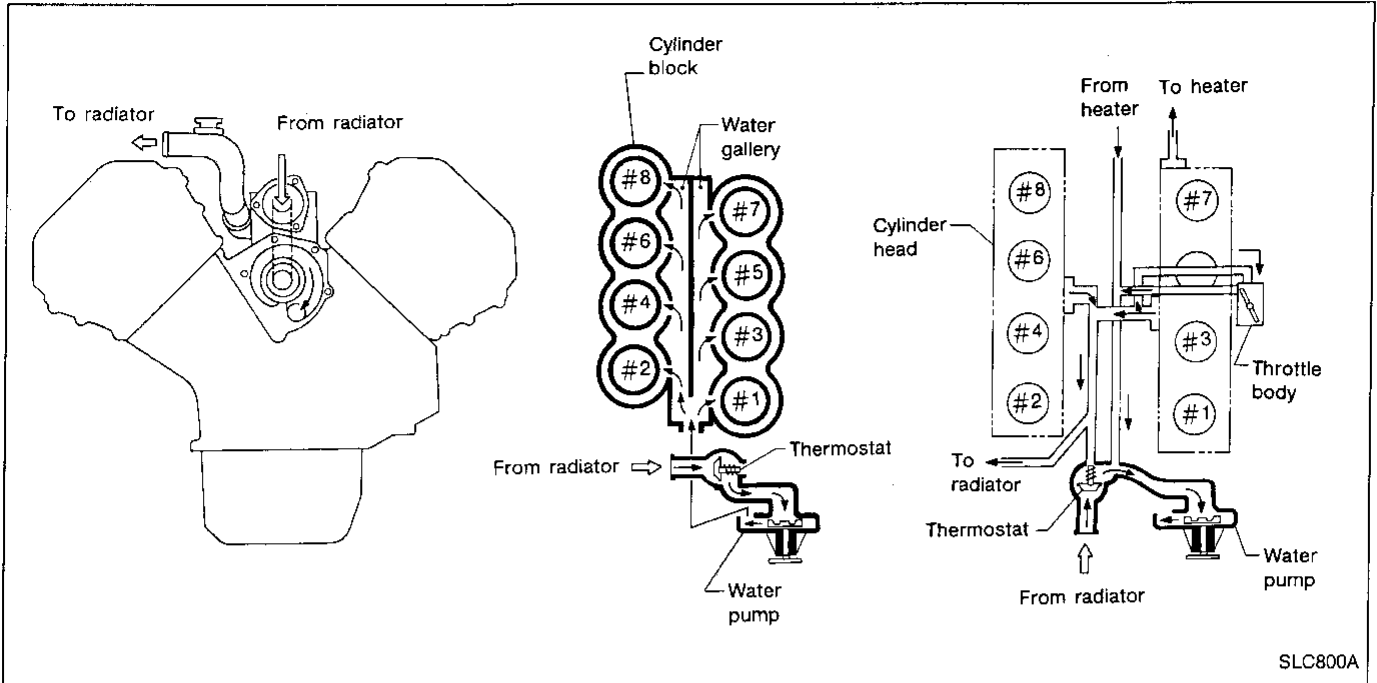

System Check

WARNING:

Never remove the filler cap nor radiator cap when the engine is hot. Serious burns could be caused by hot high pressure fluid escaping from the radiator.

Wrap a thick cloth around cap. Carefully remove the cap by first turning it a quarter turn to allow built-up pressure to escape. Then turn the cap all the way off.

ENGINE COOLING SYSTEM

System Check (Cont'd)

CHECKING COOLING SYSTEM HOSES

Check hoses for improper attachment, leaks, cracks, damage, loose connections, chafing and deterioration.

CHECKING COOLING SYSTEM FOR LEAKS

To check for leakage, apply pressure to the cooling system with a tester.

Testing pressure:
157 kPa (1.6 kg/cm², 23 psi)

CAUTION:
Higher than the specified pressure may damage radiator.

CHECKING RADIATOR CAP

To check radiator cap, apply pressure to cap with a tester.

Radiator cap relief pressure:
Standard
98 - 118 kPa (1.0 - 1.2 kg/cm², 14 - 17 psi)
Limit
59 - 98 kPa (0.6 - 1.0 kg/cm², 9 - 14 psi)

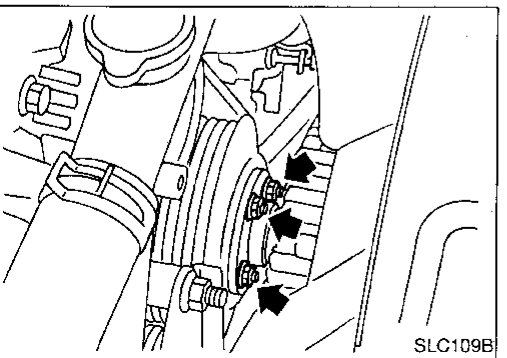
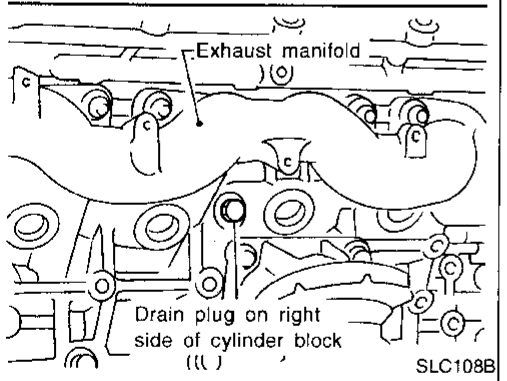
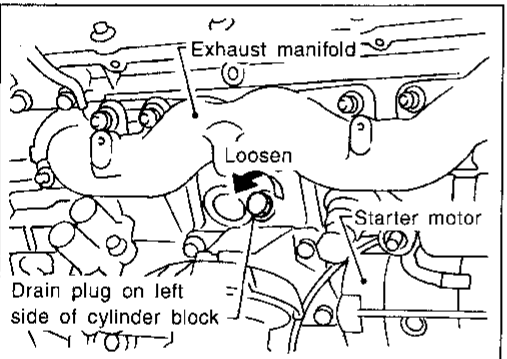
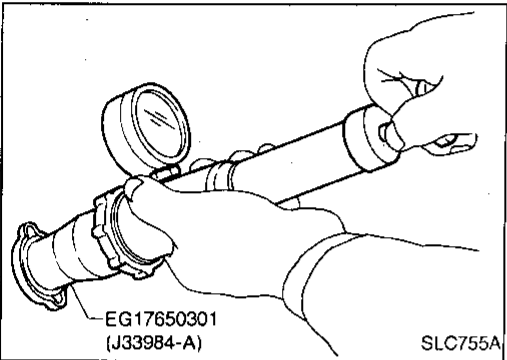
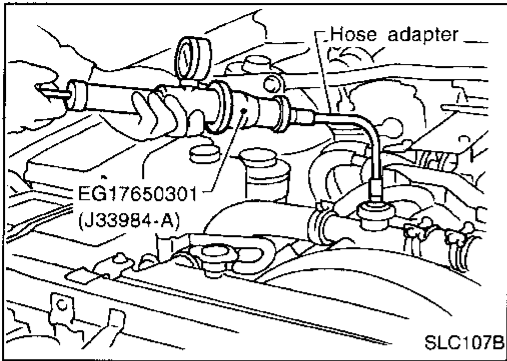

Water Pump

REMOVAL

1. Drain coolant from drain cocks on both sides of cylinder block and radiator.
2. Loosen drive belts.
3. Remove fan coupling with fan.
4. Remove idler pulley bracket and drive belt.
5. Remove water pump.

GI

MA

EM

LC

EC

FE

AT

PD

FA

RA

BR

ST

RS

BT

HA

EL

IDX

ENGINE COOLING SYSTEM

Water Pump (Cont'd)

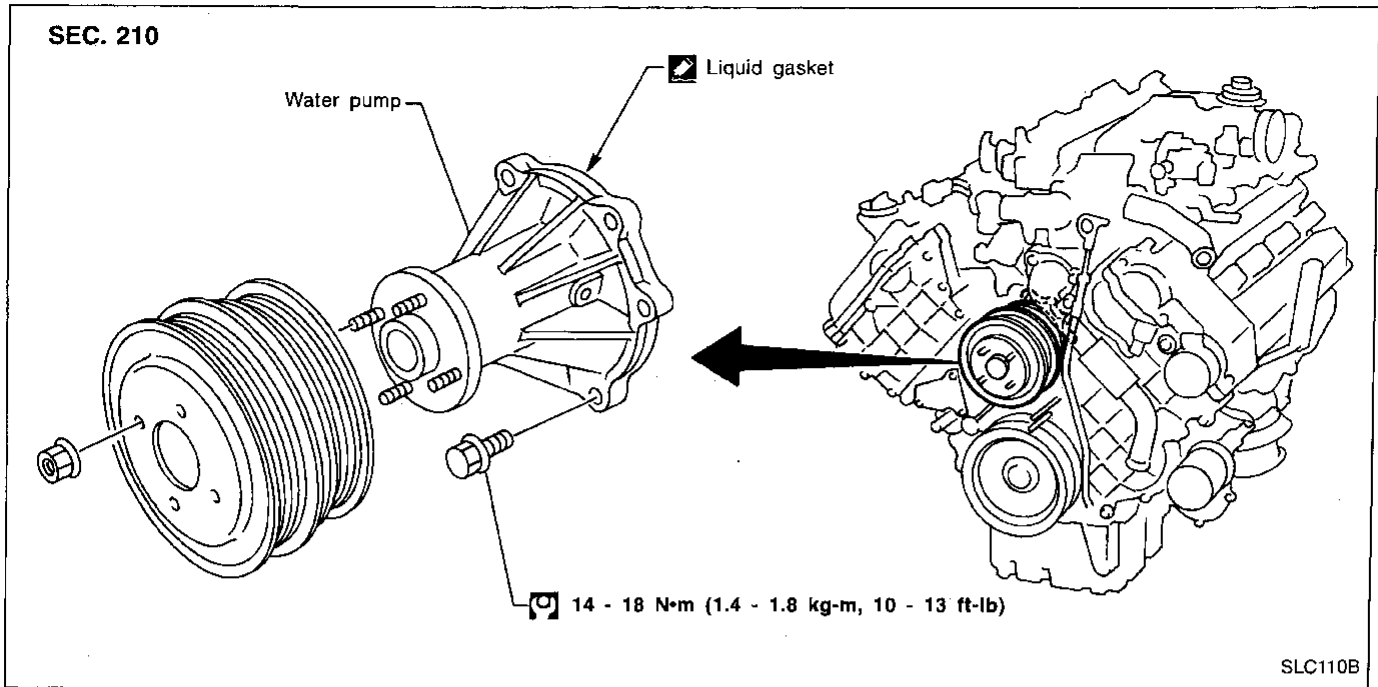

CAUTION:

- When removing water pump assembly, be careful not to get coolant on drive belt.
- Water pump cannot be disassembled and should be replaced as a unit.
- After installing water pump, connect hose and clamp securely, then check for leaks using radiator cap tester.

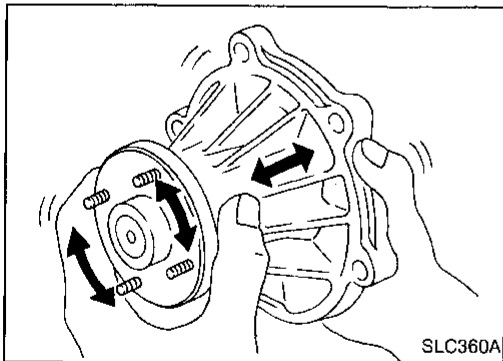

INSPECTION

1. Check for badly rusted or corroded vanes and body assembly.
2. Check for rough operation due to excessive end play.

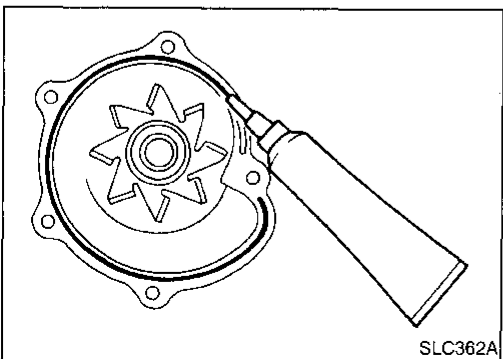

INSTALLATION

1. Use a scraper to remove old liquid gasket from water pump.
 - Also remove traces of liquid gasket from mating surface of cylinder block.
2. Apply a continuous bead of liquid gasket to mating surface of water pump.
 - Use Genuine RTV silicone sealant part No. 999 MP-A7007, Three Bond TB1207D or equivalent.

ENGINE COOLING SYSTEM

Thermostat

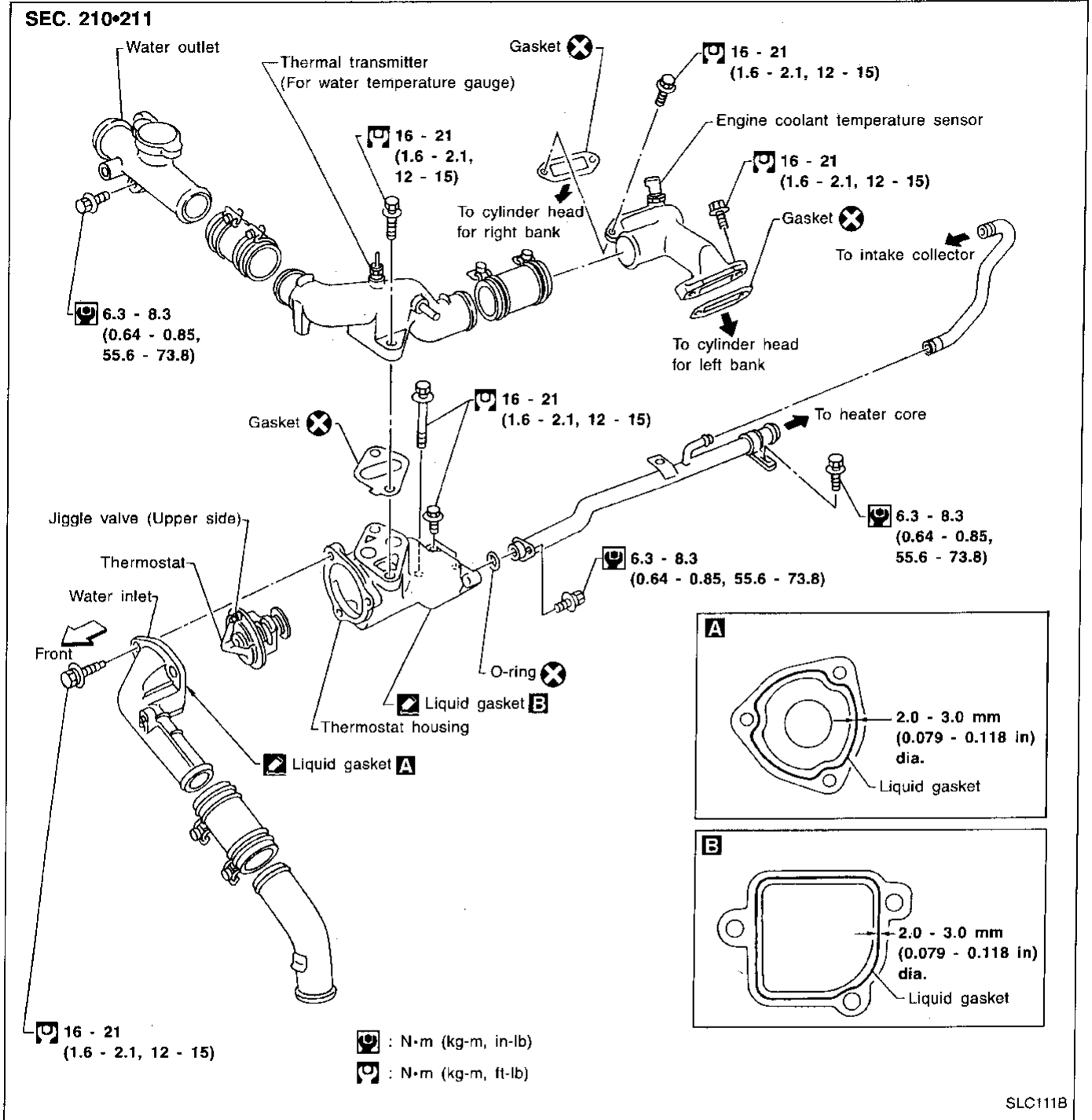

REMOVAL AND INSTALLATION

Removal

1. Drain coolant from drain cocks on both sides of cylinder block and radiator.
2. Remove front ornament cover.
3. Remove water inlet and thermostat.

ENGINE COOLING SYSTEM

Thermostat (Cont'd)

Installation

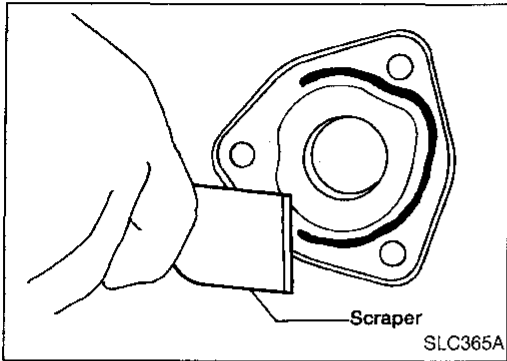

- Use a scraper to remove old liquid gasket from water inlet.
- Similarly, remove liquid gasket from mating surface.
- Clean all traces of liquid gasket using white gasoline.

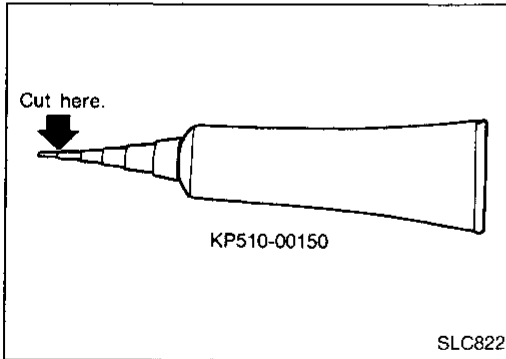

- Cut off tip of nozzle of liquid gasket tube at point shown in figure.
- Use Genuine RTV silicone sealant part No. 999 MP-A7007, Three Bond TB1207D or equivalent.

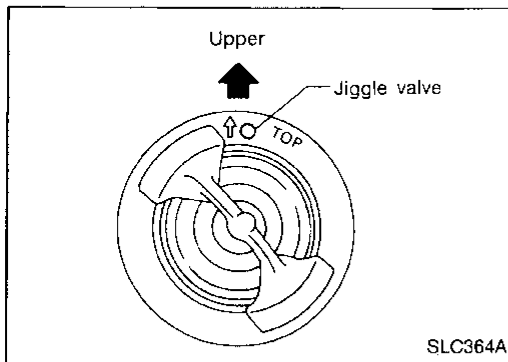

- Install thermostat with jiggle valve facing upward.
- **After installation, run engine for a few minutes, and check for leaks.**
- **Be careful not to spill coolant over engine compartment. Use a rag to absorb coolant.**

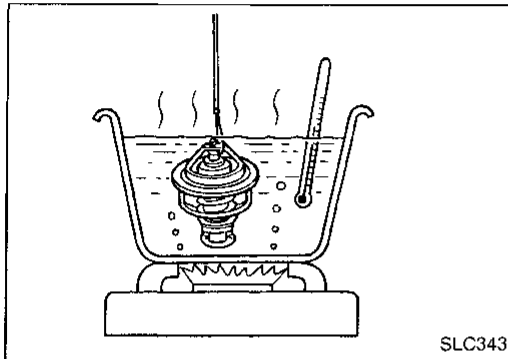

INSPECTION

1. Check for valve seating condition at ordinary temperatures. It should seat tightly.
2. Check valve opening temperature and maximum valve lift.

Valve opening temperature	°C (°F)	82 (180)
Valve lift	mm/°C (in/°F)	More than 10/95 (0.39/203)

3. Then check if valve closes at 5°C (9°F) below valve opening temperature.

ENGINE COOLING SYSTEM

Radiator

REMOVAL AND INSTALLATION

1. Remove under cover.
2. Drain coolant from radiator.
3. Disconnect radiator upper and lower hoses.
4. Remove radiator shroud.
5. Remove A/T oil cooler hoses.
6. Disconnect reservoir tank hose.
7. Remove radiator mounting bracket.
8. Remove radiator.
9. After repairing or replacing radiator, install any part removed in reverse order of removal.

When filling radiator with coolant, refer to MA section ("Changing Engine Coolant").

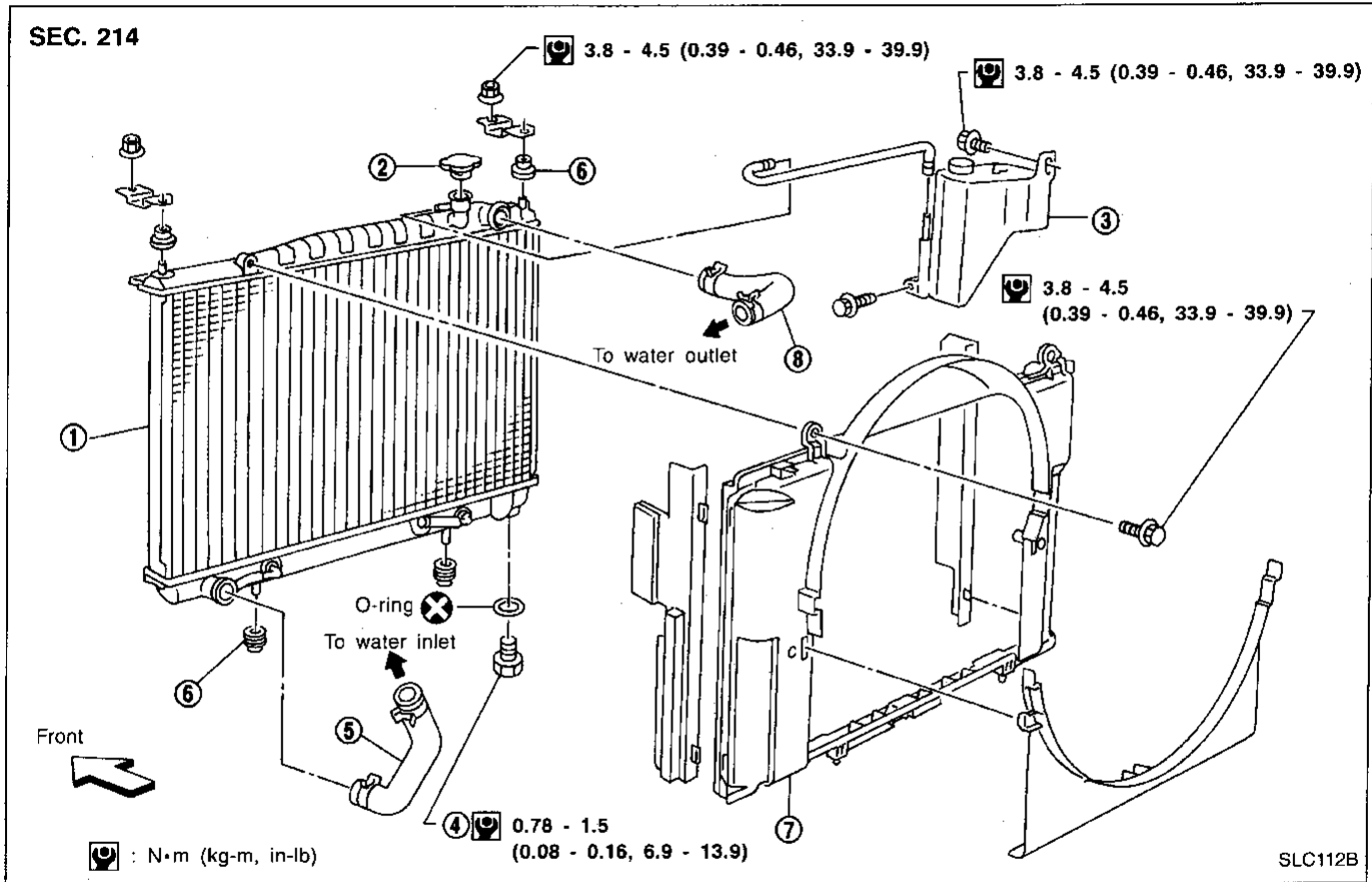

- | | | |
|-----------------------|-----------------------|-----------------------|
| ① Radiator | ④ Radiator drain cock | ⑦ Radiator shroud |
| ② Radiator filler cap | ⑤ Lower radiator hose | ⑧ Upper radiator hose |
| ③ Reservoir tank | ⑥ Mounting rubber | |

GI

MA

EM

LC

EC

FE

AT

PD

FA

RA

BR

ST

RS

BT

HA

EL

IDX

ENGINE COOLING SYSTEM

Radiator (Cont'd)

SEC. 214

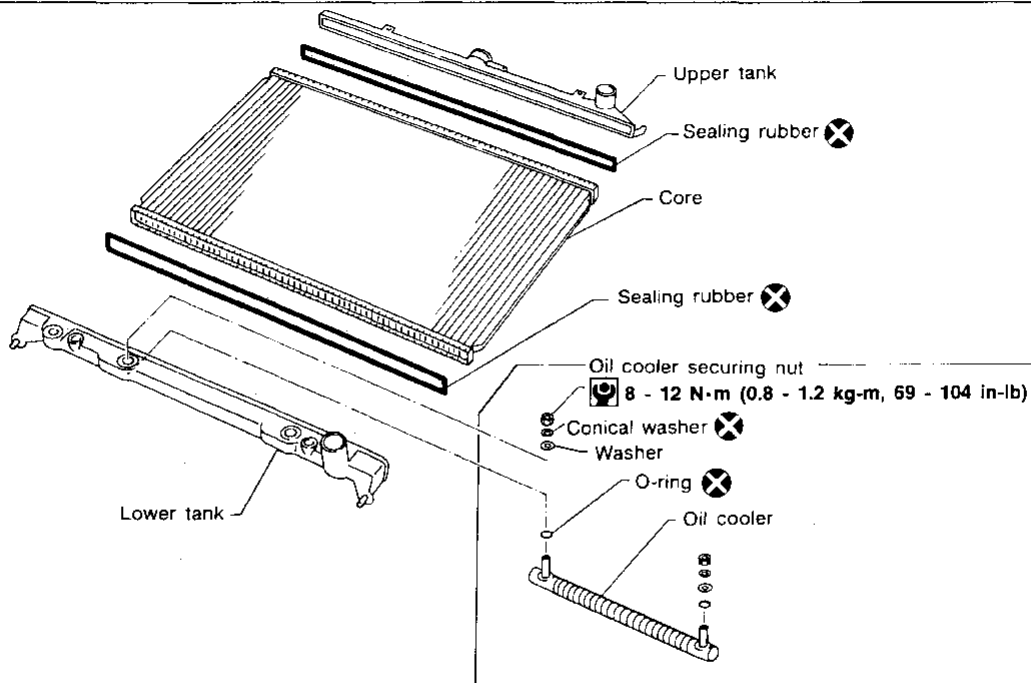

SLC882AC

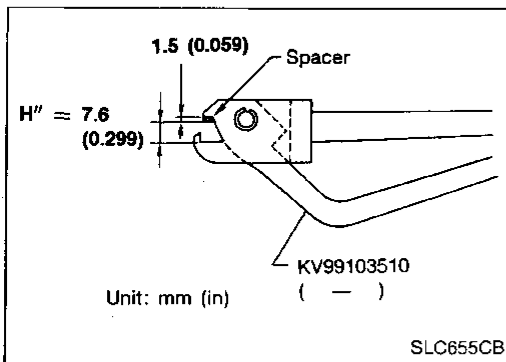

SLC655CB

PREPARATION

1. Attach the spacer to the tip of the radiator plate pliers A. Spacer specification: 1.5 mm (0.059 in) thick x 18 mm (0.71 in) wide x 8.5 mm (0.335 in) long.
2. Make sure that when radiator plate pliers A are closed dimension H'' is approx. 7.6 mm (0.299 in).
3. Adjust dimension H'' with the spacer, if necessary.

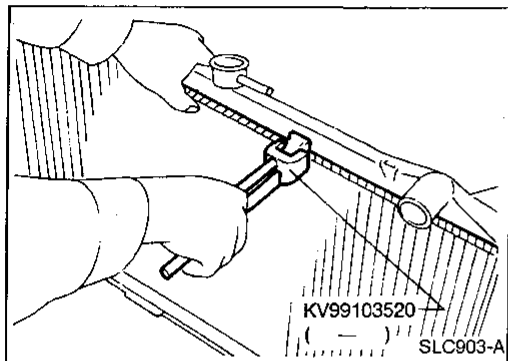

SLC903-A

DISASSEMBLY

1. Remove tank with Tool.

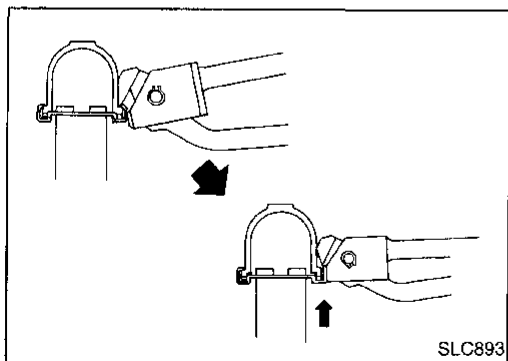

SLC893

- Grip the crimped edge and bend it upwards so that Tool slips off.
Do not bend excessively.

ENGINE COOLING SYSTEM

Radiator (Cont'd)

- In areas where Tool cannot be used, use a screwdriver to bend the edge up.

Be careful not to damage tank.

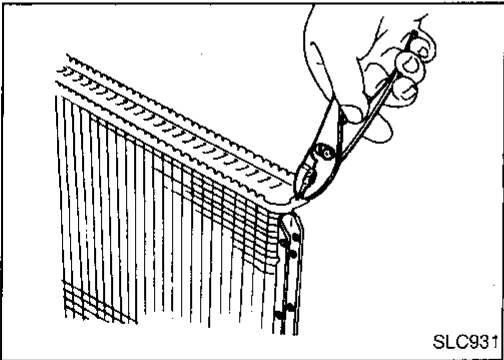
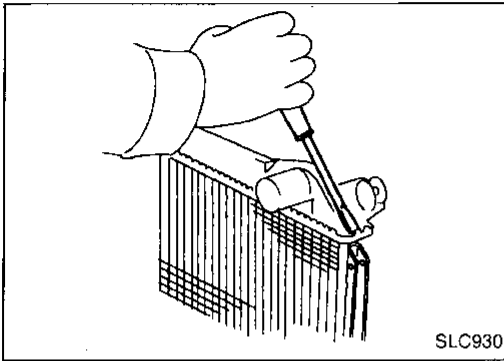

2. Make sure the edge stands straight up.
3. Remove oil cooler from tank.

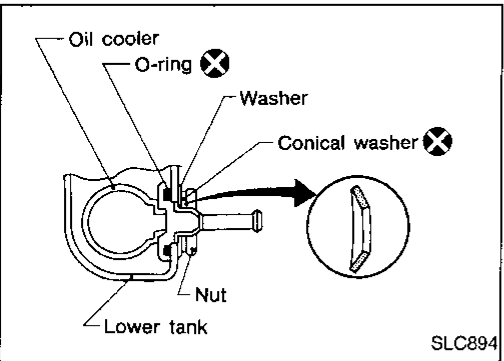

ASSEMBLY

1. Install oil cooler.

Pay attention to direction of conical washer.

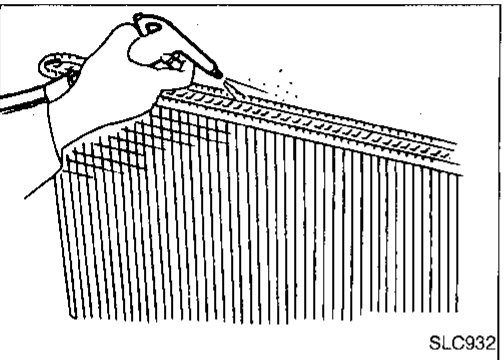

2. Clean contact portion of tank.

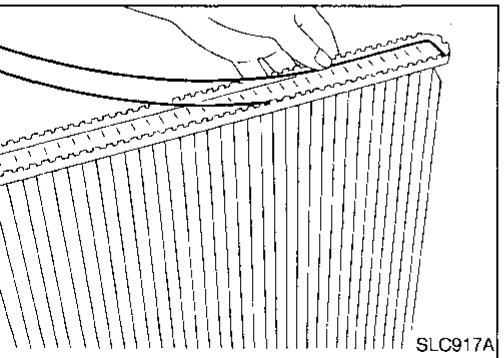

3. Install sealing rubber.
Push it in with fingers.
Be careful not to twist sealing rubber.

GI

MA

EM

LC

EC

FE

AT

PD

FA

RA

BR

ST

RS

BT

HA

EL

IDX

ENGINE COOLING SYSTEM

Radiator (Cont'd)

4. Caulk tank in specified sequence with Tool.

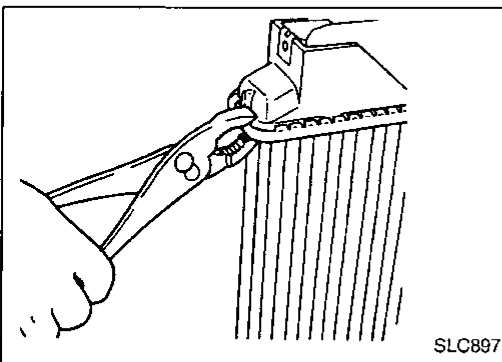
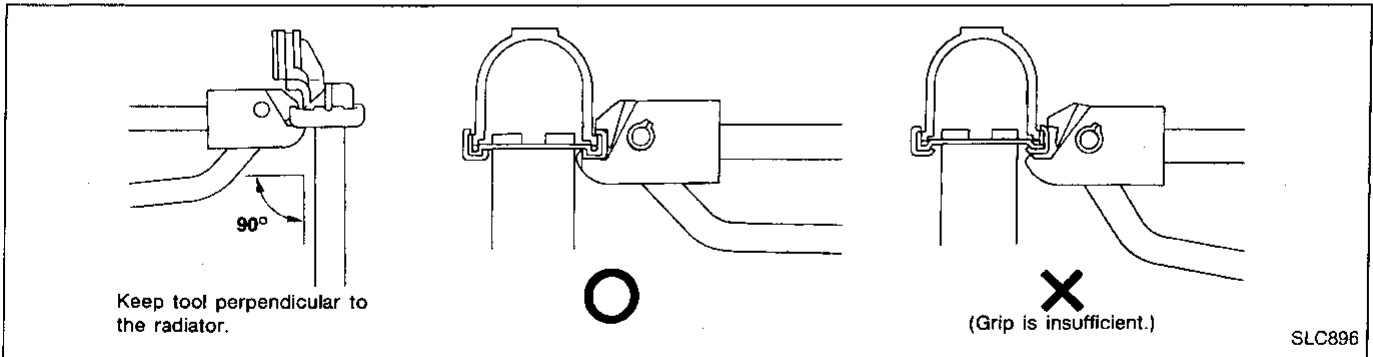
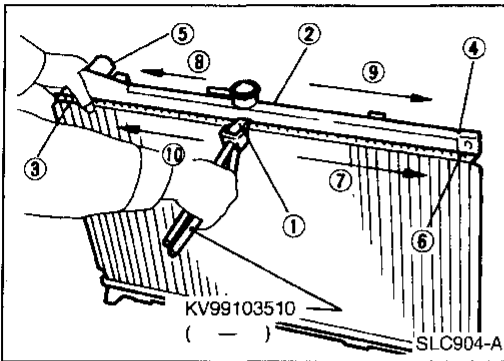

- Use pliers in the locations where Tool cannot be used.

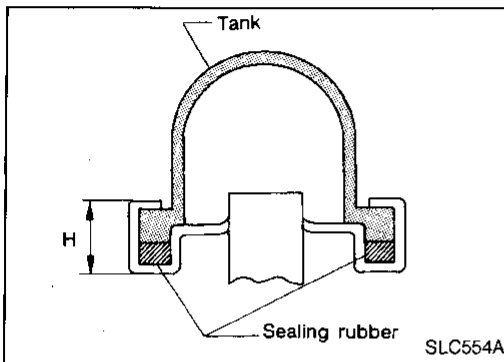

5. Make sure that the rim is completely crimped down.

Standard height "H":

8.0 - 8.4 mm (0.315 - 0.331 in)

6. Confirm that there is no leakage.

Refer to Inspection.

INSPECTION

1. Apply pressure with Tool.

Specified pressure value:

157 kPa (1.6 kg/cm², 23 psi)

WARNING:

To prevent the risk of the hose coming undone while under pressure, securely fasten it down with a hose clamp. Attach a hose to the oil cooler as well.

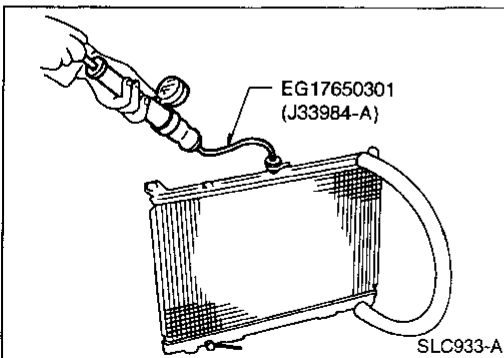

ENGINE COOLING SYSTEM

Radiator (Cont'd)

2. Check for leakage.

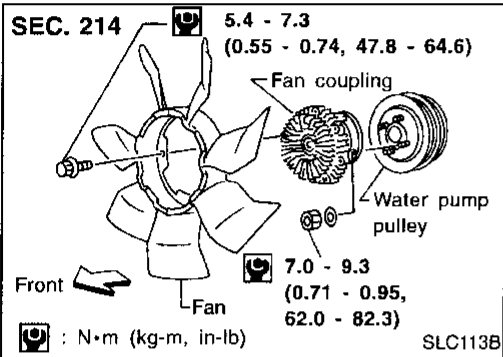
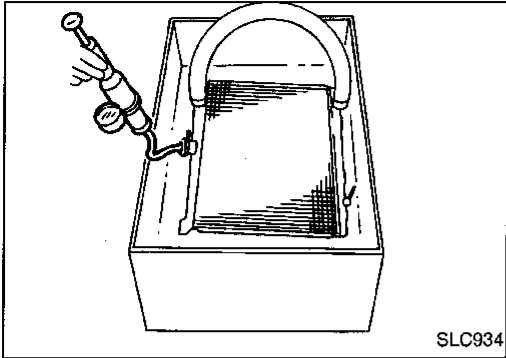

Cooling Fan (Crankshaft driven)

DISASSEMBLY AND ASSEMBLY

INSPECTION

Check fan coupling for rough operation, oil leakage or bent bimetal.

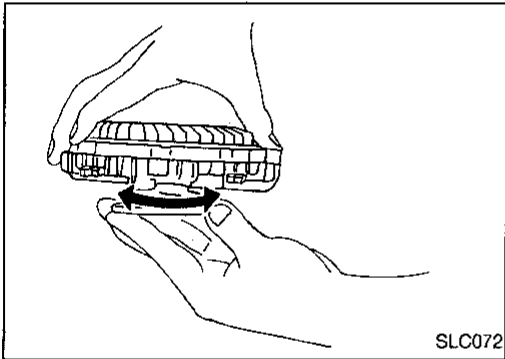

Cooling Fan (Motor driven)

Cooling fan is controlled by ECM. For details, refer to "Cooling Fan", "TROUBLE DIAGNOSIS FOR DTC P1900" in EC section.

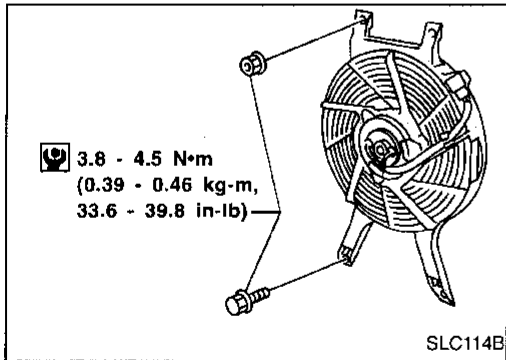

GI

MA

EM

LC

EC

FE

AT

PD

FA

RA

BR

ST

RS

BT

HA

EL

IDX

ENGINE COOLING SYSTEM

Overheating Cause Analysis

	Symptom		Check items		
Cooling system parts malfunction	Poor heat transfer	Water pump malfunction	Worn or loose drive belt	—	
		Thermostat stuck closed	—		
		Damaged fins	Dust contamination or paper clogging		—
			Mechanical damage		
	Reduced air flow	Clogged radiator cooling tube	Excess foreign material (rust, dirt, sand, etc.)	—	
		Fan coupling does not operate.	Fan coupling does not operate.		—
			Cooling fan does not operate.		
			High resistance to fan rotation		
	Damaged fan blades				
	Damaged radiator shroud	—	—	—	
Improper coolant mixture ratio	—	—	—		
Poor coolant quality	—	—	—		
Insufficient coolant	Coolant leaks	Cooling hose	Loose clamp		
			Cracked hose		
		Water pump	Poor sealing		
		Radiator cap	Loose		
			Poor sealing		
		Radiator	O-ring for damage, deterioration or improper fitting		
	Cracked radiator tank				
	Reservoir tank	Cracked radiator core			
Cracked reservoir tank					
Overflowing reservoir tank	Exhaust gas leaks into cooling system	Cylinder head deterioration			
		Cylinder head gasket deterioration			
Except cooling system parts malfunction	—	Overload on engine	Abusive driving	High engine rpm under no load	
				Driving in low gear for extended time	
				Driving at extremely high speed	
		Powertrain system malfunction	Installed improper size wheels and tires	—	
			Dragging brakes		
	Improper ignition timing.				
	Blocked or restricted air flow	Blocked bumper	—	—	
		Blocked radiator grille	Installed car brassiere		
			Mud contamination or paper clogging		
		Blocked radiator	—		
Blocked condenser		—			
Installed large fog lamp					

SERVICE DATA AND SPECIFICATIONS (SDS)

Engine Lubrication System

Oil pressure check

Engine speed rpm	Approximate discharge pressure kPa (kg/cm ² , psi)
Idle speed	More than 98 (1.0, 14)
3,000	461 - 559 (4.7 - 5.7, 67 - 81)

Regulator valve inspection

Unit: mm (in)	
Regulator valve to oil pump clearance ①	0.040 - 0.097 (0.0016 - 0.0038)

Oil pump

Unit: mm (in)		
Drive shaft to oil pump cover and housing clearance ②	0.024 - 0.069 (0.0009 - 0.0027)	GI
Driven gear to driven shaft clearance ③	0.025 - 0.064 (0.0010 - 0.0025)	MA
Drive and driven gear to oil pump housing axial clearance ④	0.08 - 0.130 (0.0031 - 0.0051)	EM
Drive and driven gear to oil pump housing radial clearance ⑤	0.125 - 0.245 (0.0049 - 0.0096)	

LC

Engine Cooling System

Thermostat

Standard	
Valve opening temperature °C (°F)	82 (180)
Valve lift mm/°C (in/°F)	More than 10/95 (0.39/203)

Radiator

Unit: kPa (kg/cm ² , psi)		
Cap relief pressure		FE
Standard	98 - 118 (1.0 - 1.2, 14 - 17)	
Limit	59 - 98 (0.6 - 1.0, 9 - 14)	AT
Leakage test pressure	157 (1.6, 23)	

EC

PD

FA

RA

BR

ST

RS

BT

HA

EL

IDX