

MAINTENANCE

SECTION MA

GI

MA

EM

LC

EC

FE

AT

PD

FA

RA

BR

ST

RS

BT

HA

EL

IDX

CONTENTS

PRECAUTIONS AND PREPARATION2	Checking EVAP Vapor Purge Lines16	
Supplemental Restraint System (SRS) "AIR BAG" and "SEAT BELT PRE-TENSIONER"2	CHASSIS AND BODY MAINTENANCE17	
Special Service Tool2	Checking Exhaust System.....17	
Commercial Service Tool.....2	Checking A/T Fluid17	
GENERAL MAINTENANCE3	Changing A/T Fluid18	
PERIODIC MAINTENANCE5	Checking Differential Gear Oil.....18	
Schedule 16	Changing Differential Gear Oil18	
Schedule 27	Balancing Wheels (Bonding Weight Type)18	
RECOMMENDED FLUIDS AND LUBRICANTS8	Tire Rotation19	
Fluids and Lubricants8	Checking Brake Fluid Level and Leaks.....19	
SAE Viscosity Number8	Checking Brake Lines and Cables20	
Anti-freeze Coolant Mixture Ratio9	Changing Brake Fluid20	
ENGINE MAINTENANCE10	Checking Disc Brake20	
Checking Drive Belts10	Checking Steering Gear and Linkage21	
Changing Engine Coolant.....11	Checking Power Steering Fluid and Lines.....21	
Checking Fuel Lines12	Lubricating Locks, Hinges and Hood Latches.....22	
Changing Fuel Filter13	Checking Seat Belts, Buckles, Retractors, Anchors and Adjusters.....22	
Changing Air Cleaner Filter13	SERVICE DATA AND SPECIFICATIONS (SDS)23	
Changing Engine Oil.....14	Engine Maintenance23	
Changing Oil Filter.....14	Chassis and Body Maintenance.....23	
Changing Spark Plugs.....15		

Supplemental Restraint System (SRS) “AIR BAG” and “SEAT BELT PRE-TENSIONER”

The Supplemental Restraint System “AIR BAG” and “SEAT BELT PRE-TENSIONER”, used along with a seat belt, help to reduce the risk or severity of injury to the driver and front passenger in a frontal collision. The Supplemental Restraint System consists of air bag modules (located in the center of the steering wheel and on the instrument panel on the passenger side), seat belt pre-tensioners, a diagnosis sensor unit, warning lamp, wiring harness and spiral cable. In addition to the supplemental air bag modules for a frontal collision, the supplemental side air bag used along with the seat belt help to reduce the risk or severity of injury to the driver and front passenger in a side collision. The supplemental side air bag consists of air bag modules (located in the outer side of front seats), satellite sensor, diagnosis sensor unit (which is one of components of supplemental air bags for a frontal collision), wiring harness, warning lamp (which is one of components of supplemental air bags for a frontal collision). Information necessary to service the system safely is included in the **RS section** in this Service Manual.

WARNING:

- To avoid rendering the SRS inoperative, which could increase the risk of personal injury or death in the event of a collision which would result in air bag inflation, all maintenance must be performed by an authorized INFINITI dealer.
- Improper maintenance, including incorrect removal and installation of the SRS, can lead to personal injury caused by unintentional activation of the system.
- Do not use electrical test equipment on any circuit related to the SRS unless instructed to in this Service Manual. SRS wiring harnesses (except “SEAT BELT PRE-TENSIONER” connector) can be identified with yellow harness connector (and with yellow harness protector or yellow insulation tape before the harness connectors).

Special Service Tool

The actual shapes of Kent-Moore tools may differ from these of special service tools illustrated here.

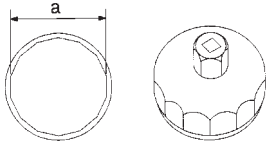
Tool number (Kent-Moore No.) Tool name	Description
KV10115801 (J38956) Oil filter wrench	 <p>NT375</p> <p>a: 64.3 mm (2.531 in)</p>

Commercial Service Tool

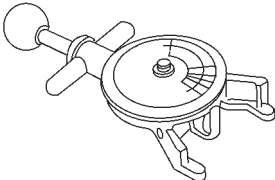
Tool name (Kent-Moore No.)	Description
Belt tension gauge (BT3373-F)	 <p>Checking drive belt tension</p> <p>AMA126</p>

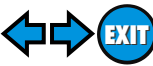

GENERAL MAINTENANCE

General maintenance includes those items which should be checked during the normal day-to-day operation of the vehicle. They are essential if the vehicle is to continue operating properly. The owners can perform the checks and inspections themselves or they can have their INFINITI dealers do them.

Item	Reference page	
OUTSIDE THE VEHICLE		
The maintenance items listed here should be performed from time to time, unless otherwise specified.		
Tires Check the pressure with a gauge periodically when at a service station, including the spare, and adjust to the specified pressure if necessary. Check carefully for damage, cuts or excessive wear.	—	GI MA EM
Wheel nuts When checking the tires, make sure no nuts are missing, and check for any loose nuts. Tighten if necessary.	—	LC
Tire rotation Tires should be rotated every 12,000 km (7,500 miles).	MA-19	EC
Wheel alignment and balance If the vehicle should pull to either side while driving on a straight and level road, or if you detect uneven or abnormal tire wear, there may be a need for wheel alignment. If the steering wheel or seat vibrates at normal highway speeds, wheel balancing may be needed.	MA-18 FA-8 RA-7	FE
Windshield wiper blades Check for cracks or wear if they do not wipe properly.	—	AT
Doors and engine hood Check that all doors and the engine hood operate smoothly as well as the trunk lid. Also make sure that all latches lock securely. Lubricate hinges and latches if necessary. Make sure that the secondary latch keeps the hood from opening when the primary latch is released.	MA-22	PD
When driving in areas using road salt or other corrosive materials, check lubrication frequently.		
INSIDE THE VEHICLE		
The maintenance items listed here should be checked on a regular basis, such as when performing periodic maintenance, cleaning the vehicle, etc.		
Lights Make sure that the headlights, stop lights, tail lights, turn signal lights, and other lights are all operating properly and installed securely. Also check headlight aim.	—	FA RA
Warning lights and buzzers/chimes Make sure that all warning lights and buzzers/chimes are operating properly.	—	BR
Windshield wiper and washer Check that the wipers and washer operate properly and that the wipers do not streak.	—	ST
Windshield defroster Check that the air comes out of the defroster outlets properly and in sufficient quantity when operating the heater or air conditioner.	—	RS
Steering wheel Check that it has the specified play. Be sure to check for changes in the steering condition, such as excessive play, hard steering or strange noises.	—	BT
Free play: Less than 35 mm (1.38 in)		
Seats Check seat position controls such as seat adjusters, seatback recliner, etc. to make sure they operate smoothly and that all latches lock securely in every position. Check that the head restraints move up and down smoothly and that the locks (if equipped) hold securely in all latched positions. Check that the latches lock securely for folding-down rear seatbacks.	—	HA
Seat belts Check that all parts of the seat belt system (e.g. buckles, anchors, adjusters and retractors) operate properly and smoothly, and are installed securely. Check the belt webbing for cuts, fraying, wear or damage.	MA-22 RS-7	EL
Accelerator pedal Check the pedal for smooth operation and make sure the pedal does not catch or require uneven effort. Keep the floor mats away from the pedal.	—	IDX
Brakes Check that the brake does not pull the vehicle to one side when applied.	—	
Brake pedal and booster Check the pedal for smooth operation and make sure it has the proper distance under it when depressed fully. Check the brake booster function. Be sure to keep the floor mats away from the pedal.	BR-10 BR-15	
Parking brake Check that the pedal has the proper travel and confirm that the vehicle is held securely on a fairly steep hill with only the parking brake applied.	BR-26	

GENERAL MAINTENANCE

Item	Reference page
Automatic transmission “Park” mechanism Check that the brake pedal must be depressed for the selector lever to be moved from the “P” position. On a fairly steep hill check that the vehicle is held securely with the selector lever in the “P” position without applying any brakes.	—
UNDER THE HOOD AND VEHICLE	
The maintenance items listed here should be checked periodically (e.g. each time you check the engine oil or refuel).	
Windshield washer fluid Check that there is adequate fluid in the tank.	—
Engine coolant level Check the coolant level when the engine is cold.	MA-11
Radiator and hoses Check the front of the radiator and clean off any dirt, insects, leaves, etc., that may have accumulated. Make sure the hoses have no cracks, deformation, deterioration or loose connections.	—
Brake fluid level Make sure that the brake fluid level is between the “MAX” and “MIN” lines on the reservoir.	MA-19
Battery Check the fluid level in each cell. It should be between the “MAX” and “MIN” lines.	—
Engine drive belts Make sure that no belt is frayed, worn, cracked or oily.	MA-10
Engine oil level Check the level on the dipstick after parking the vehicle on a level spot and turning off the engine.	MA-14
Power steering fluid level and lines Check the level on the dipstick with the engine off. Check the lines for improper attachment, leaks, cracks, etc.	MA-21
Automatic transmission fluid level Check the level on the dipstick after putting the selector lever in “P” with the engine idling.	MA-17
Exhaust system Make sure there are no loose supports, cracks or holes. If the sound of the exhaust seems unusual or there is a smell of exhaust fumes, immediately locate the trouble and correct it.	MA-17
Underbody The underbody is frequently exposed to corrosive substances such as those used on icy roads or to control dust. It is very important to remove these substances, otherwise rust will form on the floor pan, frame, fuel lines and around the exhaust system. At the end of winter, the underbody should be thoroughly flushed with plain water, being careful to clean those areas where mud and dirt can easily accumulate.	—
Fluid leaks Check under the vehicle for fuel, oil, water or other fluid leaks after the vehicle has been parked for a while. Water dripping from the air conditioner after use is normal. If you should notice any leaks or gasoline fumes are evident, check for the cause and correct it immediately.	—

Two different maintenance schedules are provided, and should be used, depending upon the conditions in which the vehicle is mainly operated. **After 60,000 miles (96,000 km) or 48 months, continue the periodic maintenance at the same mileage/time intervals.**

SCHEDULE 1

Follow Periodic Maintenance Schedule 1 if your driving habits frequently includes one or more of the following driving conditions:

- Repeated short trips of less than 5 miles (8 km).
- Repeated short trips of less than 10 miles (16 km) with outside temperatures remaining below freezing.
- Operating in hot weather in stop-and-go “rush hour” traffic.
- Extensive idling and/or low speed driving for long distances, such as police, taxi or door-to-door delivery use.
- Driving in dusty conditions.
- Driving on rough, muddy, or salt spread roads.
- Towing a trailer, using a camper or a car-top carrier.

SCHEDULE 2

Follow Periodic Maintenance Schedule 2 if none of the driving conditions shown in Schedule 1 apply to your driving habits.

GI

MA

EM

LC

EC

FE

AT

PD

FA

RA

BR

ST

RS

BT

HA

EL

IDX

Abbreviations: R = Replace I = Inspect. Correct or replace as necessary.

[]: Perform service at the mileage intervals only

MAINTENANCE OPERATION		MAINTENANCE INTERVAL																Reference page
Perform at number of miles, kilometers or months, whichever comes first.	Miles x 1,000	3.75	7.5	11.25	15	18.75	22.5	26.25	30	33.75	37.5	41.25	45	48.75	52.5	56.25	60	
	(km x 1,000)	(6)	(12)	(18)	(24)	(30)	(36)	(42)	(48)	(54)	(60)	(66)	(72)	(78)	(84)	(90)	(96)	
	Months	3	6	9	12	15	18	21	24	27	30	33	36	39	42	45	48	

EMISSION CONTROL SYSTEM MAINTENANCE

Engine oil		R	R	R	R	R	R	R	R	R	R	R	R	R	R	R	R	R	MA-14
Engine oil filter (Use part No. 15208-31U00 or equivalent)		R	R	R	R	R	R	R	R	R	R	R	R	R	R	R	R	R	MA-14
Air cleaner filter	See NOTE (1)								[R]									[R]	MA-13
EVAP vapor lines									I*									I*	MA-16
Fuel lines									I*									I*	MA-12
Drive belts	See NOTE (2)																	I*	MA-10
Engine coolant	See NOTE (3)																	R*	MA-11
Spark plugs (PLATINUM-TIPPED type)																			MA-15
Fuel filter	See NOTE (4)*																		MA-13

CHASSIS AND BODY MAINTENANCE

Brake pads & rotors			I		I		I		I		I		I		I		I		MA-20
Steering gear & linkage, axle & suspension parts			I		I		I		I		I		I		I		I		MA-21, FA-6, RA-6
Tire rotation	See NOTE (5)																		MA-3, MA-19
Exhaust system			I		I		I		I		I		I		I		I		MA-17
Ventilation air filter			I		R		I		R		I		R		I		R		HA-111
Brake lines & cables					I				I				I				I		MA-20
Automatic transmission fluid & differential gear oil	See NOTE (6)				I				I				I				I		MA-17, MA-18
Supplemental air bag system and supplemental side air bag systems	See NOTE (7)																		RS-14
ASCD vacuum hoses					I				I				I				I		EL-256

- NOTE:**
- (1) If operating mainly in dusty conditions, more frequent maintenance may be required.
 - (2) After 60,000 miles (96,000 km) or 48 months, inspect every 15,000 miles (24,000 km) or 12 months.
 - (3) After 60,000 miles (96,000 km) or 48 months, replace every 30,000 miles (48,000 km) or 24 months.
 - (4) When the filter becomes clogged, the vehicle speed cannot be increased as the driver wishes. In such an event, replace the filter.
 - (5) Refer to "Tire rotation" under the "GENERAL MAINTENANCE" heading earlier in this section.
 - (6) If towing a trailer, using a camper or a car-top carrier, or driving on rough or muddy roads, change (not just inspect) oil at every 30,000 miles (48,000 km) or 24 months.
 - (7) Inspect the supplemental air bag and supplemental side air bag systems 10 years after the date of manufacture noted on the FMVSS certification label.
- * Maintenance items and intervals with "*" are recommended by INFINITI for reliable vehicle operation. The owner need not perform such maintenance in order to maintain the emission warranty or manufacturer recall liability. Other maintenance items and intervals are required.

MA-6

Schedule 1

PERIODIC MAINTENANCE



Abbreviations: R = Replace I = Inspect. Correct or replace as necessary.

[]: Perform service at the mileage intervals only

MAINTENANCE OPERATION

Perform at number of miles, kilometers or months, whichever comes first.	Miles x 1,000 (km x 1,000) Months	MAINTENANCE INTERVAL								Reference page
		7.5	15	22.5	30	37.5	45	52.5	60	
		(12)	(24)	(36)	(48)	(60)	(72)	(84)	(96)	
		6	12	18	24	30	36	42	48	

EMISSION CONTROL SYSTEM MAINTENANCE

Engine oil		R	R	R	R	R	R	R	R	MA-14
Engine oil filters (Use Part No. 15208-31U00 or equivalent)		R	R	R	R	R	R	R	R	MA-14
Air cleaner filter					[R]				[R]	MA-13
EVAP vapor lines					I*				I*	MA-16
Fuel lines					I*				I*	MA-12
Drive belts	See NOTE (1)								I*	MA-10
Engine coolant	See NOTE (2)								R*	MA-11
Spark plugs (PLATINUM-TIPPED Type)					Replace every 105,000 miles (169,000 km)					MA-15
Fuel filter	See NOTE (3)*									MA-13

CHASSIS AND BODY MAINTENANCE

Brake lines & cables			I		I		I		I	MA-20
Brake pads & rotors			I		I		I		I	MA-20
Automatic transmission fluid & differential gear oil			I		I		I		I	MA-17, MA-18
Exhaust system					I				I	MA-17
Ventilation air filter			R		R		R		R	HA-111
Steering gear & linkage, axle & suspension parts					I				I	MA-21, FA-6, RA-6
Tire rotation	See NOTE (4)									MA-3, MA-19
Supplemental air bag and supplemental side air bag systems	See NOTE (5)									RS-14
ASCD vacuum hoses			I		I		I		I	EL-256

- NOTE:**
- (1) After 60,000 miles (96,000 km) or 48 months, inspect every 15,000 miles (24,000 km) or 12 months.
 - (2) After 60,000 miles (96,000 km) or 48 months, replace every 30,000 miles (48,000 km) or 24 months.
 - (3) When the filter becomes clogged, the vehicle speed cannot be increased as the driver wishes. In such an event, replace the filter.
 - (4) Refer to "Tire rotation" under the "GENERAL MAINTENANCE" heading earlier in this section.
 - (5) Inspect the supplemental air bag and supplemental side air bag systems 10 years after the date of manufacture noted on the FMVSS certification label.
- * Maintenance items and intervals with "*" are recommended by INFINITI for reliable vehicle operation. The owner need not perform such maintenance in order to maintain the emission warranty or manufacturer recall liability. Other maintenance items and intervals are required.

MA-7

Schedule 2

PERIODIC MAINTENANCE

IDX

EL

HA

BT

RS

ST

BR

RA

FA

PD

AT

FE

EC

LG

EM

MA

GI



RECOMMENDED FLUIDS AND LUBRICANTS

Fluids and Lubricants

	Capacity (Approximate)			Recommended fluids and lubricants
	US measure	Imp measure	Liter	
Engine oil				
Drain and refill				
With oil filter	5-5/8 qt	4-5/8 qt	5.3	<ul style="list-style-type: none"> • API Certification Mark • API grade SG/SH, Energy Conserving I & II or API grade SJ, Energy Conserving*2 • ILSAC grade GF-I & GF-II*2
Without oil filter	5-1/4 qt	4-3/8 qt	5.0	
Dry engine (Engine overhaul)	6-1/2 qt	5-1/2 qt	6.2	
Cooling system (With reservoir)	12-3/8 qt	10-1/4 qt	11.7	Genuine Nissan anti-freeze coolant or equivalent
Differential gear oil	2-3/4 pt	2-1/4 pt	1.3	API GL-5*2
Automatic transmission fluid	11-1/8 qt	9-1/4 qt	10.5	Nissan Matic "D" (Continental U.S. and Alaska) or Canada Nissan Automatic Transmission Fluid*1
Power steering fluid	—	—	—	Genuine Nissan PSF II or equivalent*4
Brake fluid	—	—	—	Genuine Brake Fluid*3 or equivalent DOT 3 (US FMVSS No. 116)
Multi-purpose grease	—	—	—	NLGI No. 2 (Lithium soap base)

*1: Dexron™ III/Mercon™ or equivalent may also be used. Outside the continental United States and Alaska contact an INFINITI dealership for more information regarding suitable fluids, including recommended brand(s) of Dexron™ III/Mercon™ Automatic Transmission Fluid.

*2: For further details, see "SAE Viscosity Number".

*3: For more information regarding suitable fluids, contact an INFINITI dealership.

*4: Genuine Nissan PSF, Canada Nissan Automatic Transmission Fluid, Dexron™ III/Mercon™ or equivalent ATF may also be used.

SAE Viscosity Number

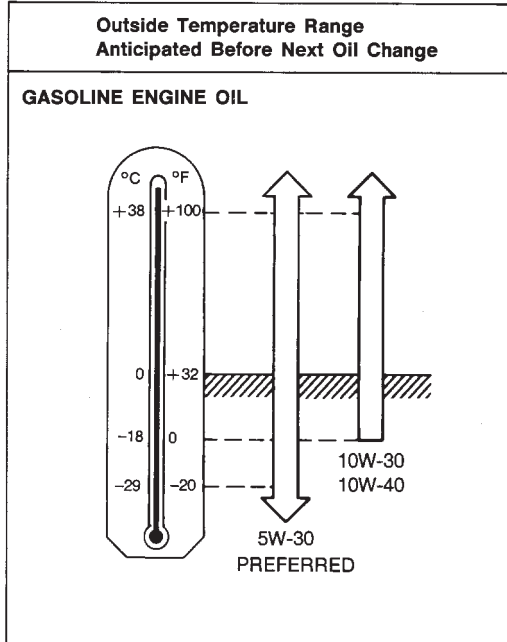

TI0008

SAE 5W-30 viscosity oil is preferred for all temperatures. SAE 10W-30, 10W-40 viscosity oil may be used if the ambient temperature is above -18°C (0°F).

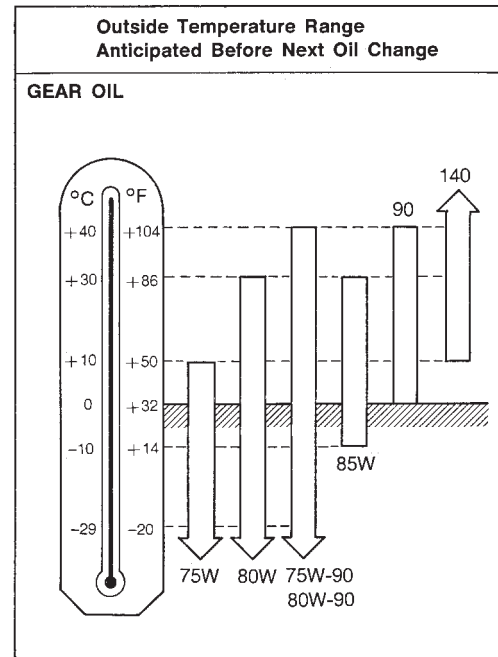

TI0003

80W-90 for differential gear is preferable for ambient temperatures below 40°C (104°F).

Anti-freeze Coolant Mixture Ratio

The engine cooling system is filled at the factory with a high-quality, year-round, anti-freeze coolant solution. The anti-freeze solution contains rust and corrosion inhibitors. Therefore, additional cooling system additives are not necessary.

CAUTION:

When adding or replacing coolant, be sure to use only a Genuine NISSAN anti-freeze coolant or equivalent with the proper mixture ratio of 50% anti-freeze and 50% demineralized water/distilled water.

Outside temperature down to		Anti- freeze	Demineralized water or distilled water
°C	°F		
-35	-30	50%	50%

Other types of coolant solutions may damage the cooling system.

GI

MA

EM

LC

EC

FE

AT

PD

FA

RA

BR

ST

RS

BT

HA

EL

IDX

Checking Drive Belts

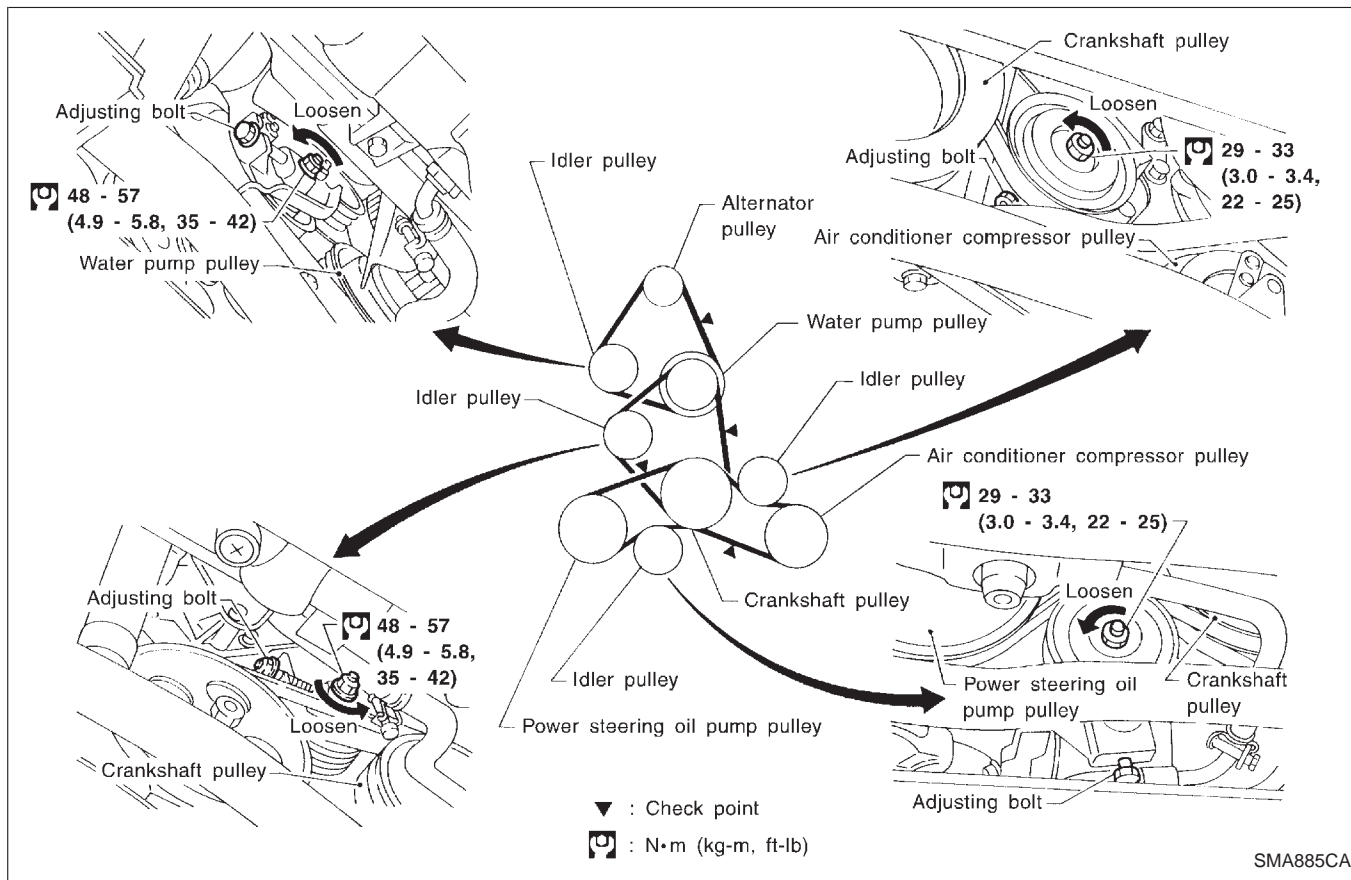

1. Inspect belt for cracks, fraying, wear and oil. If necessary, replace.
2. Inspect drive belt deflection or tension at a point on the belt midway between pulleys.
 - Check belt tension using belt tension gauge (BT33373-F or equivalent).
 - Inspect drive belt deflection or tension when engine is cold. Adjust if belt deflection exceeds the limit or if belt tension is not within specifications.
 - Drive belt tension can also be checked at other points on the belt.

Belt deflection and tension:

	Deflection adjustment Unit: mm (in)			Tension adjustment*1 Unit: N (kg, lb)		
	Used belt		New belt	Used belt		New belt
	Limit	After adjustment		Limit	After adjustment	
Alternator	8 (0.31)	4 - 5 (0.16 - 0.20)	3.5 - 4.5 (0.138 - 0.177)	196 (20, 44)	736 - 814 (75 - 83, 165 - 183)	843 - 922 (86 - 94, 190 - 207)
Air conditioner compressor	13 (0.51)	9 - 10 (0.35 - 0.39)	8 - 9 (0.31 - 0.35)	196 (20, 44)	500 - 579 (51 - 59, 112 - 130)	608 - 686 (62 - 70, 137 - 154)
Power steering oil pump	14 (0.55)	9 - 10 (0.35 - 0.39)	8 - 9 (0.31 - 0.35)	137 (14, 31)	353 - 432 (36 - 44, 79 - 97)	451 - 530 (46 - 54, 101 - 119)
Water pump	9 (0.35)	6 - 7 (0.24 - 0.28)	5 - 6 (0.20 - 0.24)	196 (20, 44)	539 - 618 (55 - 63, 121 - 139)	657 - 736 (67 - 75, 148 - 165)
Applied pushing force	98 N (10 kg, 22 lb)			—		

*1: If the belt tension gauge cannot be installed at check points shown, check drive belt tension at a different location on the belt.

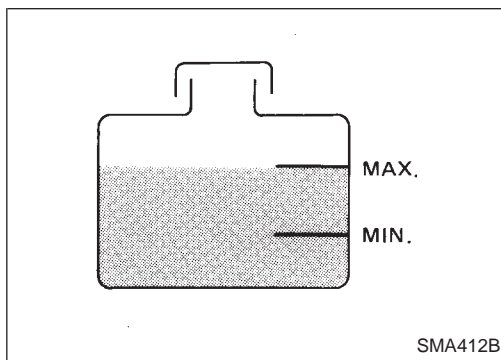
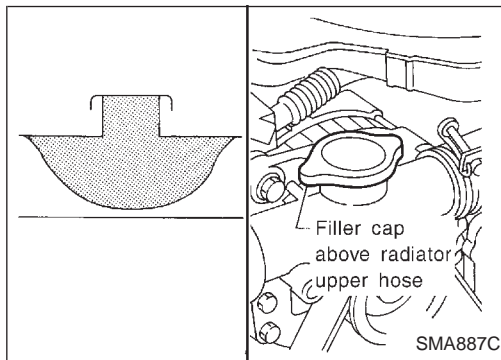
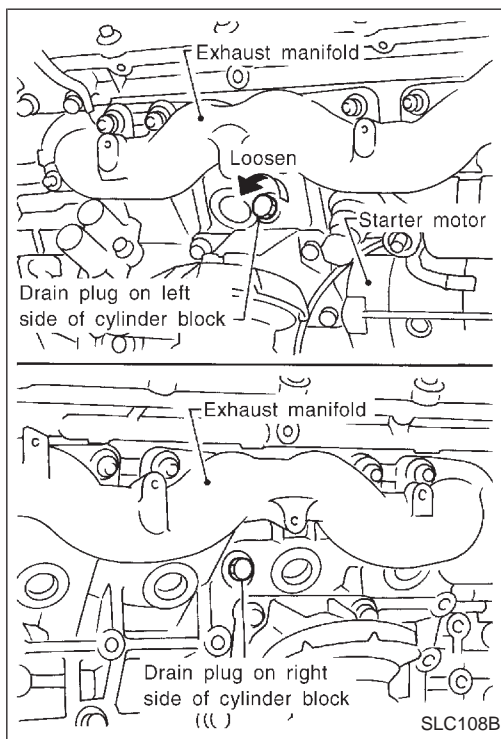
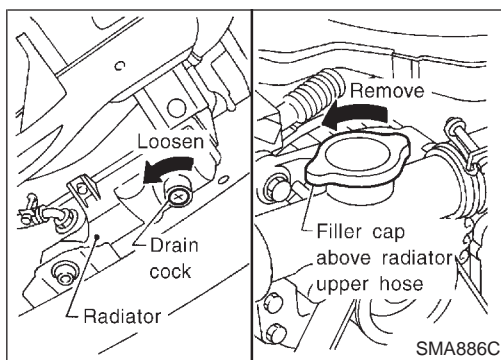

Changing Engine Coolant

WARNING:

- To avoid being scalded, never change the coolant when the engine is hot.
- Wrap a thick cloth around cap and carefully remove the cap. First, turn the cap a quarter of a turn to release built-up pressure. Then turn the cap all the way.

CAUTION:

Do not open the radiator cap while changing engine coolant. Fill the radiator only from the filler cap above the radiator upper hose with radiator cap closed.

— DRAINING ENGINE COOLANT —

1. Set the air conditioner system as follows to prevent coolant from remaining in the system.
 - a. Turn ignition switch ON and set temperature controller to maximum HOT position.
 - b. Wait 10 seconds before turning ignition switch OFF.
2. Open drain cock at the bottom of radiator and remove filler cap above radiator upper hose.
3. Remove reservoir tank, drain coolant, then clean reservoir tank. Install it temporarily.

● Be careful not to allow coolant to contact drive belts.

4. Remove drain plugs on both sides of cylinder block.
5. Check drained coolant for contaminants such as rust, corrosion or discoloration. If contaminated, flush engine cooling system. Refer to "FLUSHING COOLING SYSTEM" on the next page.

— REFILLING ENGINE COOLANT —

6. Install reservoir tank, radiator drain cock and drain plugs on both sides of cylinder block.
- **Apply sealant to the thread of drain plug.**
 ⚙️: 15 - 25 N·m (1.5 - 2.5 kg-m, 11 - 18 ft-lb)
7. Fill radiator from filler cap above radiator upper hose and reservoir tank to specified level.
- **Use genuine Nissan anti-freeze coolant or equivalent mixed with water (distilled or demineralized).**
 Refer to "RECOMMENDED FLUIDS AND LUBRICANTS", MA-9.

Engine coolant capacity (With reservoir tank):

11.7ℓ (12-3/8 US qt, 10-1/4 Imp qt)

Reservoir tank:

0.7ℓ (3/4 US qt, 5/8 Imp qt)

- **Pour coolant through coolant filler neck slowly to allow air in system to escape.**
8. Warm up engine to normal operating temperature without filler cap above radiator upper hose installed at idle speed.

If coolant overflows radiator filler hole, install filler cap above radiator upper hose.

9. Run engine at 2,500 rpm for 10 seconds and return to idle speed with radiator cap installed.

- Repeat two or three times.

Watch coolant temperature gauge so as not to overheat the engine.

10. Run engine and cool it down.

GI

MA

EM

LC

EC

FE

AT

PD

FA

RA

BR

ST

RS

BT

HA

EL

IDX

ENGINE MAINTENANCE

Changing Engine Coolant (Cont'd)

- Cool down using a fan to reduce the time.
- If necessary, refill radiator from filler cap above radiator upper hose up to specified level.
- 11. Refill reservoir tank to MAX level line.
- 12. Repeat steps 8 through 11 two or more times with filler cap above radiator upper hose installed until coolant level no longer drops.
- 13. Check cooling system for leaks with engine running.
- 14. Warm up engine, and check for sound of coolant flow while running engine from idle up to 3,000 rpm with heater temperature controller set at several positions between COOL and WARM.
- Sound may be noticeable at heater water cock.
- 15. If sound is heard, bleed air from cooling system by repeating steps 8 through 11 with filler cap above radiator upper hose installed until coolant level no longer drops.
- **Clean excess coolant from engine.**

— FLUSHING COOLING SYSTEM —

1. Fill radiator from filler cap above radiator upper hose and reservoir tank with water and reinstall filler cap above radiator upper hose.
2. Run engine and warm it up to normal operating temperature.
3. Rev engine 2 or 3 times under no-load.
4. Stop engine and wait until it cools down.
5. Drain water.
6. Repeat steps 1 through 5 until clear water begins to drain from radiator.

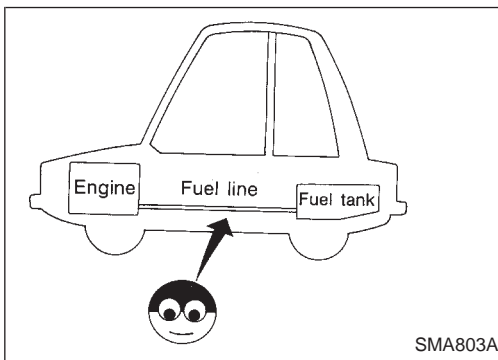

Checking Fuel Lines

Inspect fuel lines and tank for improper attachment, leaks, cracks, damage, chafing or deterioration.
If necessary, repair or replace.

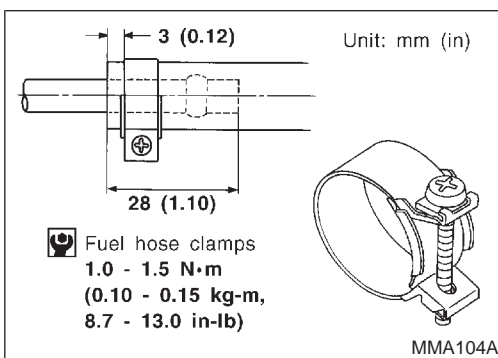

CAUTION:

Tighten high-pressure rubber hose clamp so that clamp end is 3 mm (0.12 in) from hose end.
Tightening torque specifications are the same for all rubber hose clamps.
Ensure that screw does not contact adjacent parts.

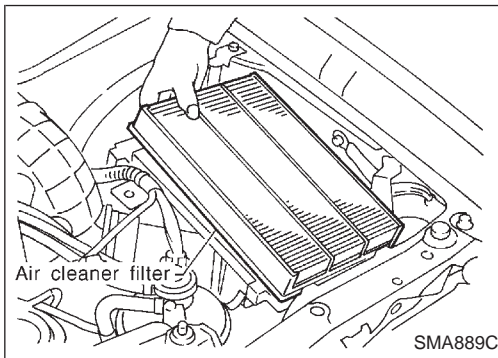
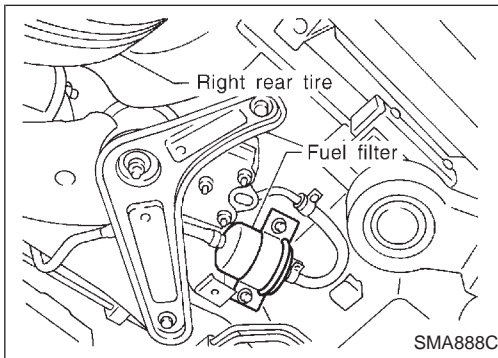
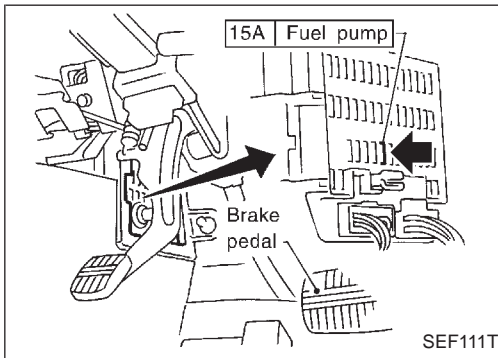
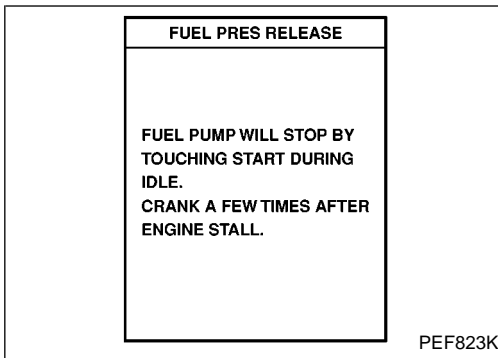

Changing Fuel Filter

WARNING:

Before removing fuel filter, release fuel pressure from fuel line to eliminate danger.

1. Start engine.
2. Perform "FUEL PRESSURE RELEASE" in "WORK SUPPORT" mode with CONSULT-II.
3. After engine stalls, crank engine two or three times to make sure that fuel pressure is released.
4. Turn ignition switch off.

1. Remove fuel pump fuse.
2. Start engine.
3. After engine stalls, crank engine two or three times to make sure that fuel pressure is released.
4. Turn ignition switch off and install fuel pump fuse.

5. Loosen fuel hose clamps.
 6. Replace fuel filter.
- Be careful not to spill fuel over engine compartment. Place a shop towel to absorb fuel.
 - Use a high-pressure type fuel filter. Do not use a synthetic resinous fuel filter.
 - When tightening fuel hose clamps, refer to "Checking Fuel Lines".

Changing Air Cleaner Filter

The viscous paper type filter does not need cleaning.

GI

MA

EM

LC

EC

FE

AT

PD

FA

RA

BR

ST

RS

BT

HA

EL

IDX

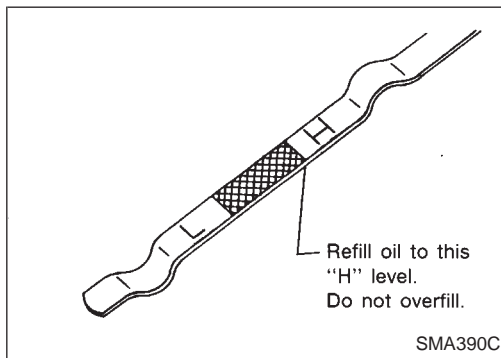
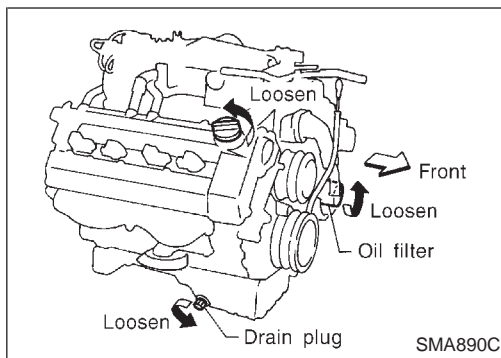

Changing Engine Oil

WARNING:

- Be careful not to burn yourself, as the engine oil is hot.
- Prolonged and repeated contact with used engine oil may cause skin cancer; try to avoid direct skin contact with used oil. If skin contact is made, wash thoroughly with soap or hand cleaner as soon as possible.

1. Warm up engine, and check for oil leakage from engine components.
2. Stop engine and wait more than 15 minutes.
3. Remove drain plug and oil filler cap.
4. Drain oil and refill with new engine oil.

Oil specifications and viscosity:

- API Certification Mark
- API grade SG/SH, Energy Conserving I & II or API grade SJ, Energy Conserving
- ILSAC grade GF-I & GF-II
- See "RECOMMENDED FLUIDS AND LUBRICANTS" (MA-8).

Oil capacity (Approximately):

Drain and refill	
With oil filter	5.3ℓ (5-5/8 US qt, 4-5/8 Imp qt)
Without oil filter	5.0ℓ (5-1/4 US qt, 4-3/8 Imp qt)
Dry engine (engine overhaul)	6.2ℓ (6-1/2 US qt, 5-1/2 Imp qt)

CAUTION:

- Be sure to clean drain plug and install with new washer.
Drain plug:
: 29 - 39 N·m (3.0 - 4.0 kg-m, 22 - 29 ft-lb)
 - The refill capacity depends on the oil temperature and drain time. Use these specifications for reference only. Always use the dipstick to determine when the proper amount of oil is in the engine.
 - Make sure direction of oil level gauge is correct before checking oil level.
5. Warm up engine and check area around drain plug and oil filter for oil leakage.
 6. Stop engine and wait for more than 15 minutes.
 7. Check oil level.

Changing Oil Filter

1. Remove oil filter from underneath the engine compartment with a suitable tool.

WARNING:

Be careful not to burn yourself, as the engine and the engine oil are hot.

ENGINE MAINTENANCE

Changing Oil Filter (Cont'd)

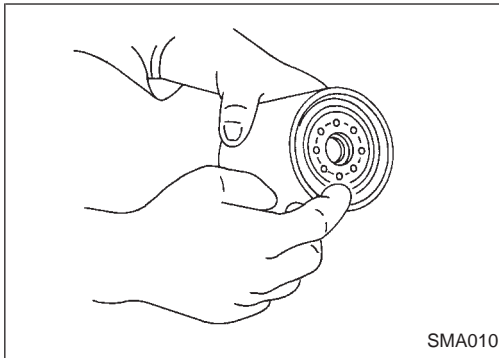

- Clean oil filter mounting surface on cylinder block. Coat rubber seal of new oil filter with engine oil.
- Oil filter is provided with a relief valve. Use Genuine Nissan oil filter or equivalent.

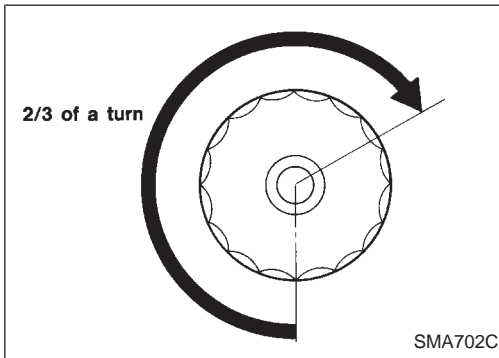

- Screw in the oil filter until a slight resistance is felt, then tighten additionally more than 2/3 turn.
- Add engine oil.

Refer to Changing Engine Oil (MA-14).

- Clean excess oil from engine block.

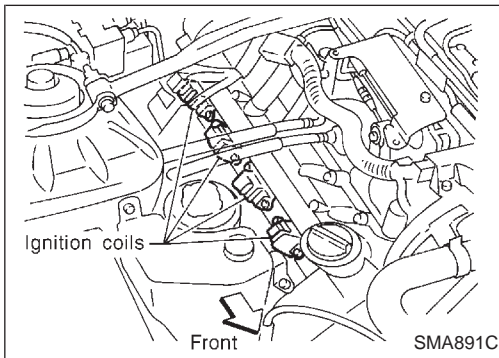

Changing Spark Plugs

- Remove air duct.
- Remove ornament cover.
- Disconnect ignition coil harness connector.
- Loosen ignition coil fixing bolts and pull out ignition coils.

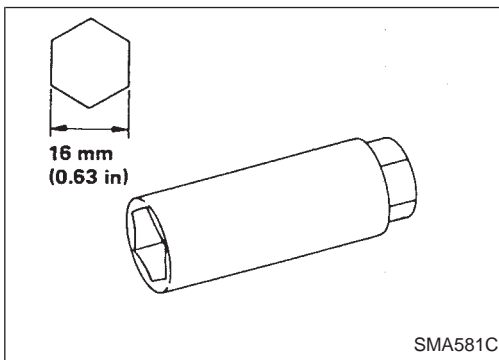

- Remove spark plugs with suitable spark plug wrench.

Spark plug (Platinum-tipped type):

Make	NGK
Standard type	PFR5G-11
Hot type	PFR4G-11
Cold type	PFR6G-11

Use standard type spark plug for normal condition.

The hot type spark plug is suitable when fouling may occur with the standard type spark plug such as:

- frequent engine starts
- low ambient temperatures

The cold type spark plug is suitable when spark knock may occur with the standard type spark plug such as:

- extended highway driving
- frequent high engine revolution

Gap (Nominal): 1.1 mm (0.043 in)

⚙️: 20 - 29 N·m (2.0 - 3.0 kg·m, 14 - 22 ft-lb)

GI

MA

EM

LC

EC

FE

AT

PD

FA

RA

BR

ST

RS

BT

HA

EL

IDX

ENGINE MAINTENANCE

Changing Spark Plugs (Cont'd)

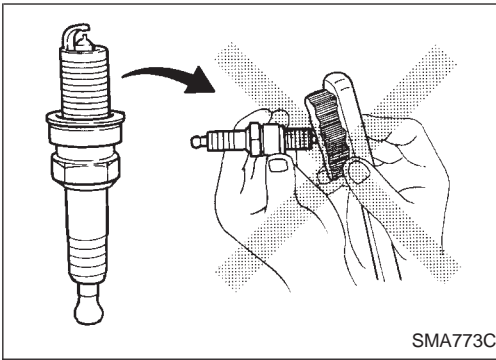

- Do not use a wire brush for cleaning.
- If plug tip is covered with carbon, spark plug cleaner may be used.

Cleaner air pressure:

Less than 588 kPa (6 kg/cm², 85 psi)

Cleaning time:

Less than 20 seconds

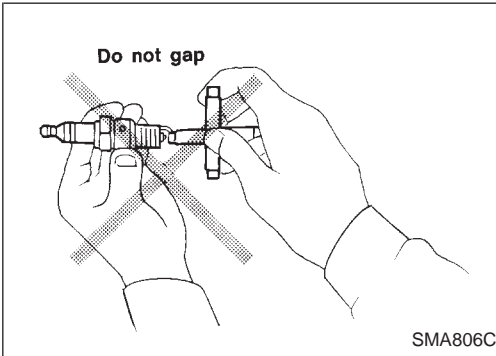

- Checking and adjusting plug gap is not required.

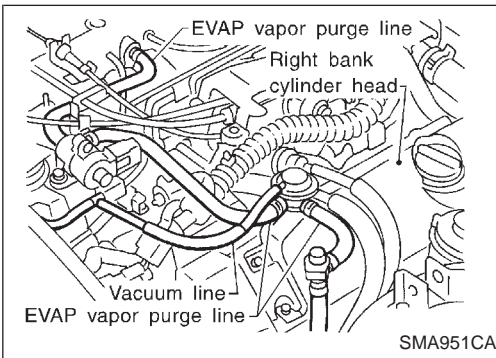

Checking EVAP Vapor Purge Lines

1. Visually inspect EVAP vapor purge lines for improper attachment, cracks, damage, loose connections, chafing or deterioration.
2. Inspect vacuum relief valve of fuel tank filler cap for clogging, sticking, etc.

Refer to EC section, "EVAPORATIVE EMISSION SYSTEM".

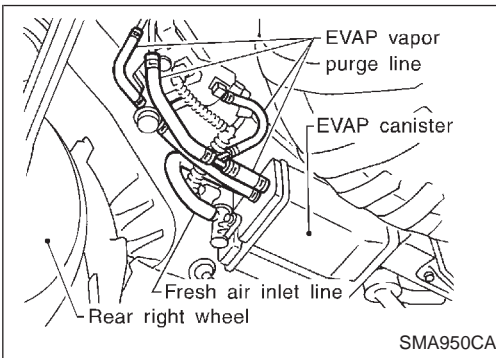

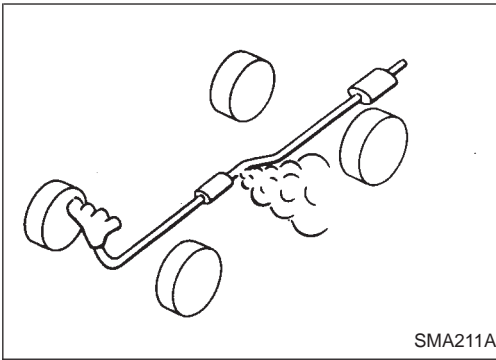

Checking Exhaust System

Check exhaust pipes, muffler and mounting for improper attachment and for leaks, cracks, damage, loose connections, chafing and deterioration.

GI

MA

EM

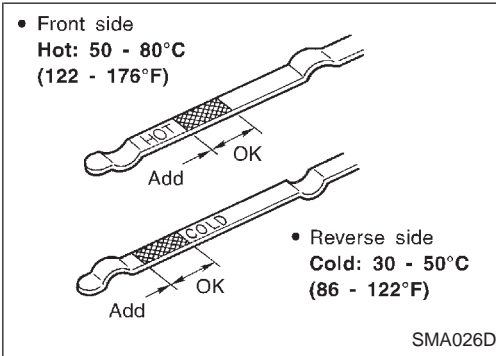

Checking A/T Fluid

1. Warm up engine.
2. Check for fluid leakage.
3. Before driving, fluid level can be checked at fluid temperatures of 30 to 50°C (86 to 122°F) using "COLD" range on dipstick.
 - a. Park vehicle on level surface and set parking brake.
 - b. Start engine and move selector lever through each gear position. Leave selector lever in "P" position.
 - c. Check fluid level with engine idling.
 - d. Remove dipstick and wipe clean with lint-free paper.
 - e. Re-insert dipstick into charging pipe as far as it will go.
 - f. Remove dipstick and note reading. If reading is at low side of range, add fluid to the charging pipe.

LC

EC

FE

AT

PD

Do not overfill.

4. Drive vehicle for approximately 5 minutes in urban areas.
5. Re-check fluid level at fluid temperatures of 50 to 80°C (122 to 176°F) using "HOT" range on dipstick.

FA

RA

BR

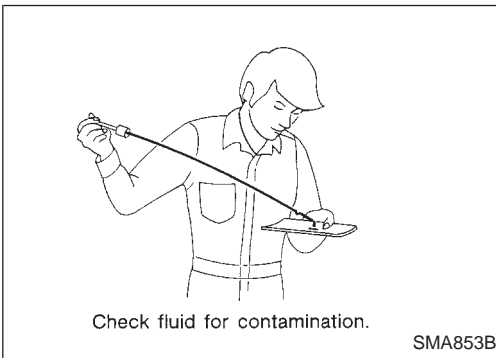

6. Check fluid condition.
 - If fluid is very dark or smells burned, refer to AT section for checking operation of A/T. Flush cooling system after repair of A/T.
 - If A/T fluid contains frictional material (clutches, bands, etc.), replace radiator and flush cooler line using cleaning solvent and compressed air after repair of A/T. Refer to LC section, "Radiator".

ST

RS

BT

HA

EL

IDX

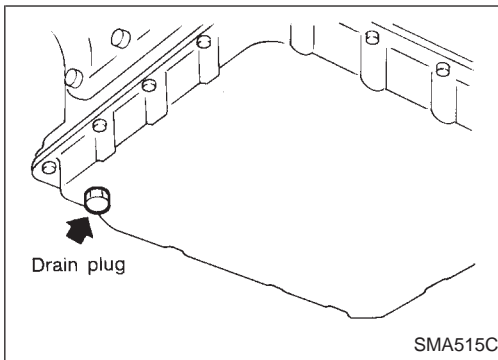

Changing A/T Fluid

1. Warm up A/T fluid.
2. Stop engine.
3. Drain A/T fluid from drain plug and refill with new A/T fluid. Always refill same volume with drained fluid.

Fluid grade:

Nissan Matic "D" (Continental U.S. and Alaska) or Canada Nissan Automatic Transmission Fluid
Refer to "RECOMMENDED FLUIDS AND LUBRICANTS", MA-8.

Fluid capacity (With torque converter):

10.5ℓ (11-1/8 US qt, 9-1/4 Imp qt)

Drain plug:

: **29 - 39 N·m (3.0 - 4.0 kg·m, 22 - 29 ft·lb)**

4. Run engine at idle speed for five minutes.
5. Check fluid level and condition. Refer to "Checking A/T Fluid". If fluid is still dirty, repeat step 2. through 5.

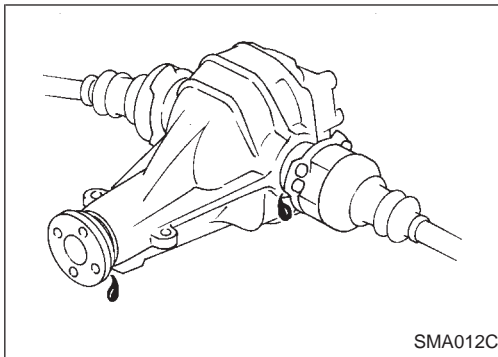

Checking Differential Gear Oil

1. Check for oil leakage and oil level.

Filler plug:

: **59 - 98 N·m (6 - 10 kg·m, 43 - 72 ft·lb)**

Changing Differential Gear Oil

1. Drain oil from drain plug and refill with new gear oil.
2. Check oil level.

Oil grade: API GL-5

Viscosity:

See "RECOMMENDED FUEL AND LUBRICANTS", MA-8.

Capacity:

1.3ℓ (2-3/4 US pt, 2-1/4 Imp pt)

Drain plug:

: **59 - 98 N·m (6 - 10 kg·m, 43 - 72 ft·lb)**

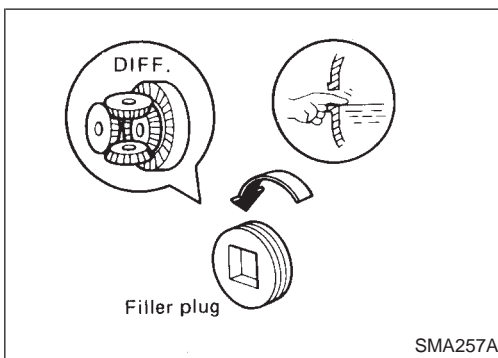

Balancing Wheels (Bonding Weight Type)

REMOVAL

1. Remove inner and outer balance weights from the road wheel.

CAUTION:

Be careful not to scratch the road wheel during removal procedures.

2. Using releasing agent, remove double-faced adhesive tape from the road wheel.

CAUTION:

- **Be careful not to scratch the road wheel during removal.**

MA-18

Balancing Wheels (Bonding Weight Type) (Cont'd)

- After removing double-faced adhesive tape, wipe clean traces of releasing agent from the road wheel.

WHEEL BALANCE ADJUSTMENT

- If a tire balance machine has adhesion balance weight mode settings and drive-in weight mode setting, select and adjust a drive-in weight mode suitable for road wheels.
1. Set road wheel on wheel balancer using the center hole as a guide. Start the tire balance machine.
 2. When inner and outer unbalance values are shown on the wheel balancer indicator, multiply outer unbalance value by 1.6 to determine balance weight that should be used. Select the outer balance weight with a value closest to the calculated value above and install it to the designated outer position of, or at the designated angle in relation to the road wheel.

CAUTION:

- Do not install the inner balance weight before installing the outer balance weight.
- Before installing the balance weight, be sure to clean the mating surface of the road wheel.

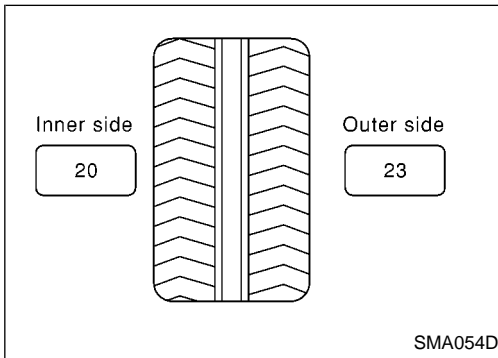

Indicated unbalance value $\times 5/3$ = balance weight to be installed

Calculation example:

$23 \text{ g (0.81 oz)} \times 5/3 = 38.33 \text{ g (1.35 oz)} = 40 \text{ g (1.41 oz)}$ balance weight (closer to calculated balance weight value)

Note that balance weight value must be closer to the calculated balance weight value.

Example:

$37.4 = 35 \text{ g (1.23 oz)}$

$37.5 = 40 \text{ g (1.41 oz)}$

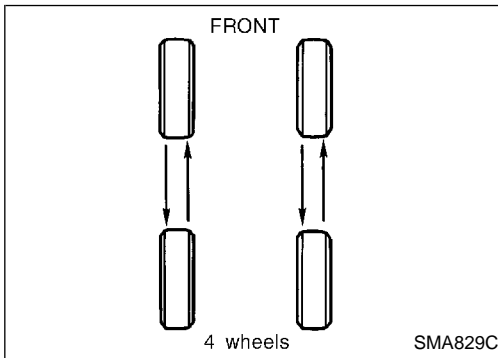

Tire Rotation

- Do not include the T-type spare tire when rotating the tires.

Wheel nuts:

: 98 - 118 N·m (10.0 - 12.0 kg·m, 72 - 87 ft·lb)

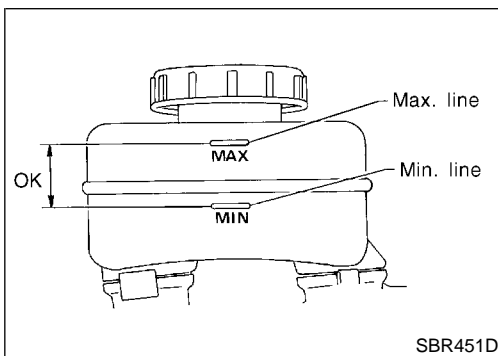

Checking Brake Fluid Level and Leaks

- If fluid level is extremely low, check brake system for leaks.

GI

MA

EM

LC

EC

FE

AT

PD

FA

RA

BR

ST

RS

BT

HA

EL

IDX

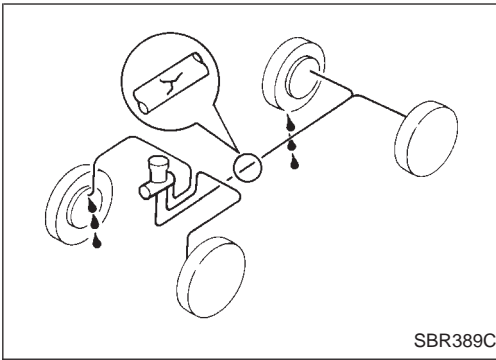

Checking Brake Lines and Cables

- Check brake fluid lines and parking brake cables for improper attachment and for leaks, chafing, abrasions, deterioration, etc.

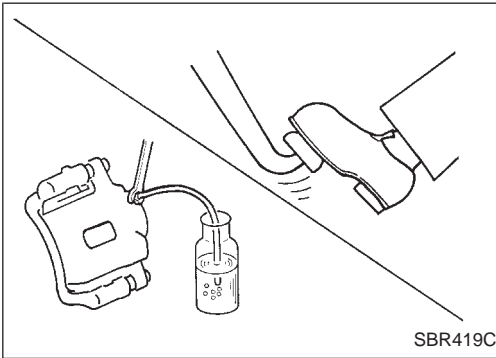

Changing Brake Fluid

1. Drain brake fluid from each air bleeder valve.
 2. Refill until new brake fluid comes out from each air bleeder valve.
- Use same procedure as in bleeding hydraulic system to refill brake fluid.
Refer to BR section, "CHECK AND ADJUSTMENT".
- Refill with recommended Genuine Brake Fluid or equivalent DOT 3 (US FMVSS No. 116). Refer to "RECOMMENDED FLUIDS AND LUBRICANTS", MA-8.
 - Never reuse drained brake fluid.
 - Be careful not to splash brake fluid on painted areas.

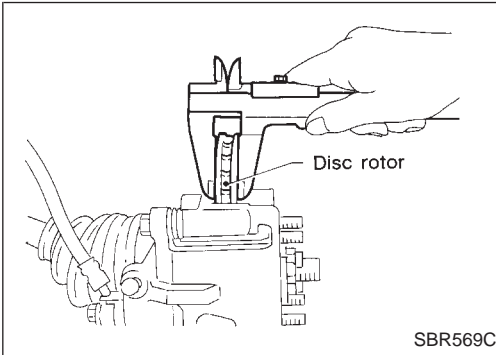

Checking Disc Brake

ROTOR

- Check condition and thickness.

Unit: mm (in)

	Front	Rear
Standard thickness	28.0 (1.102)	16.0 (0.630)
Minimum thickness	26.0 (1.024)	14.0 (0.551)

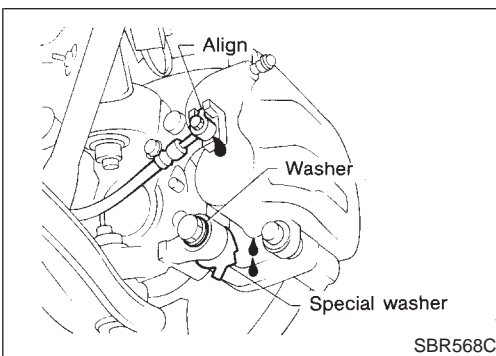

CALIPER

- Check operation and for leakage.

CHASSIS AND BODY MAINTENANCE

Checking Disc Brake (Cont'd)

PAD

- Check pad thickness from inspection hole.
- Check for uneven wear or damage.

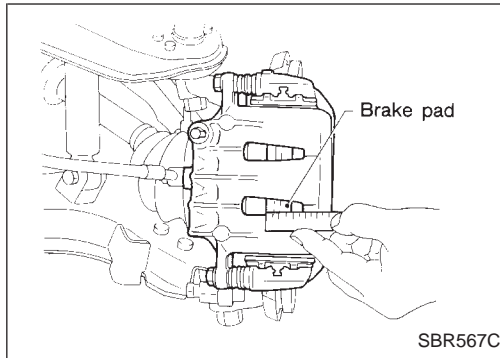

Unit: mm (in)

	Front	Rear
Standard thickness	11.0 (0.433)	10.0 (0.394)
Minimum thickness	2.0 (0.079)	

GI

MA

EM

Checking Steering Gear and Linkage

STEERING GEAR

- Check gear housing and boots for looseness, damage or grease leakage.
- Check connection with steering column for looseness.

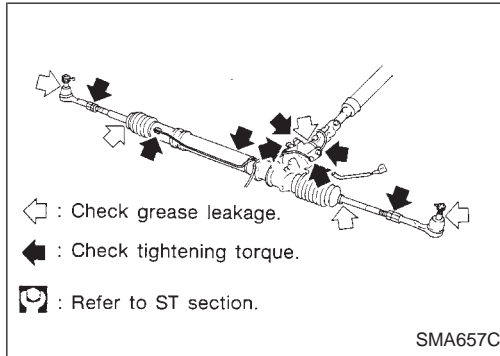

LC

EC

STEERING LINKAGE

- Check ball joint, dust cover and other component parts for looseness, wear, damage or grease leakage.

FE

AT

Checking Power Steering Fluid and Lines

- Check fluid level with engine off.
- Check fluid level with dipstick on reservoir cap. Use "HOT" range at fluid temperatures of 50 to 80°C (122 to 176°F). Use "COLD" range at fluid temperatures of 0 to 30°C (32 to 86°F).

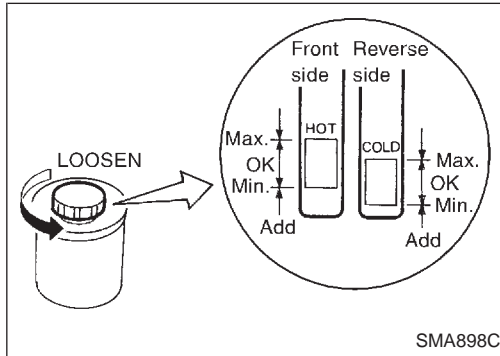

PD

FA

CAUTION:

- Do not overfill.
- Recommended fluid is Genuine Nissan PSF II or equivalent.

RA

BR

- Check lines for improper attachment, leaks, cracks, damage, loose connections, chafing or deterioration.
- Check rack boots for accumulation of power steering fluid.

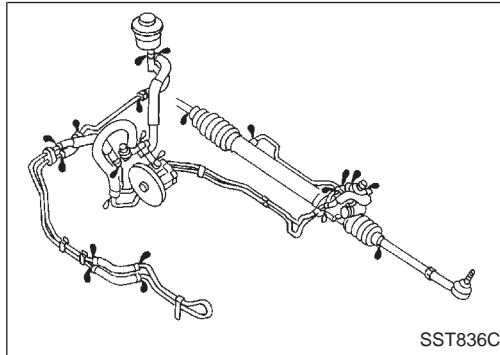

ST

RS

BT

HA

EL

IDX

Lubricating Locks, Hinges and Hood Latches

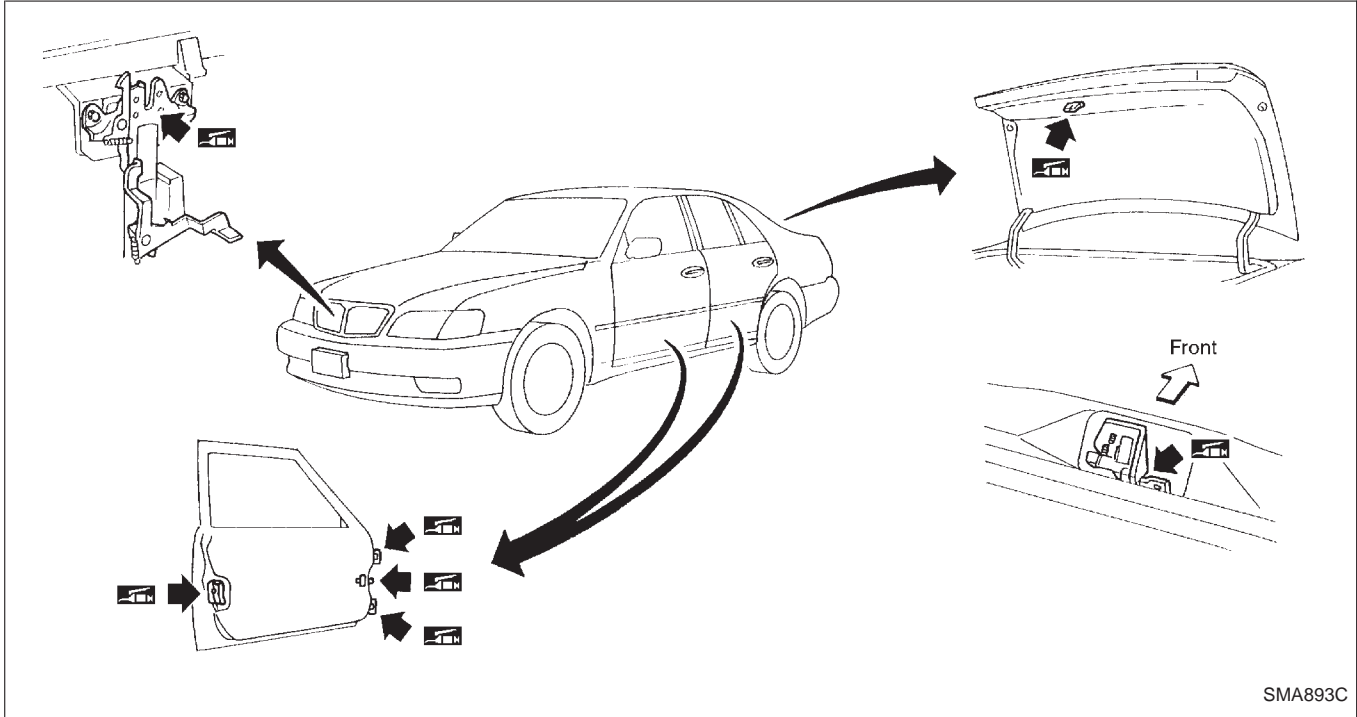

Checking Seat Belts, Buckles, Retractors, Anchors and Adjusters

CAUTION:

- After any collision, inspect all seat belt assemblies, including retractors and other attached hardware (i.e. anchor bolt, guide rail set). Nissan recommends to replace all seat belt assemblies in use during a collision, unless not damaged and properly operating after minor collision. Also inspect seat belt assemblies not in use during a collision, and replace if damaged or improperly operating. Seat belt pre-tensioner should be replaced even if the seat belts are not in use during a frontal collision where the driver and passenger air bags are deployed.
- If any component of seat belt assembly is questionable, do not repair. Replace as seat belt assembly.
- If webbing is cut, frayed, or damaged, replace belt assembly.
- Never oil tongue and buckle.
- Use a genuine seat belt assembly.

For details, refer to "Seat Belt Inspection", "SEAT BELTS" in RS section.

Anchor bolt

43 - 55 (4.4 - 5.6, 32 - 41)

: N·m (kg-m, ft-lb)

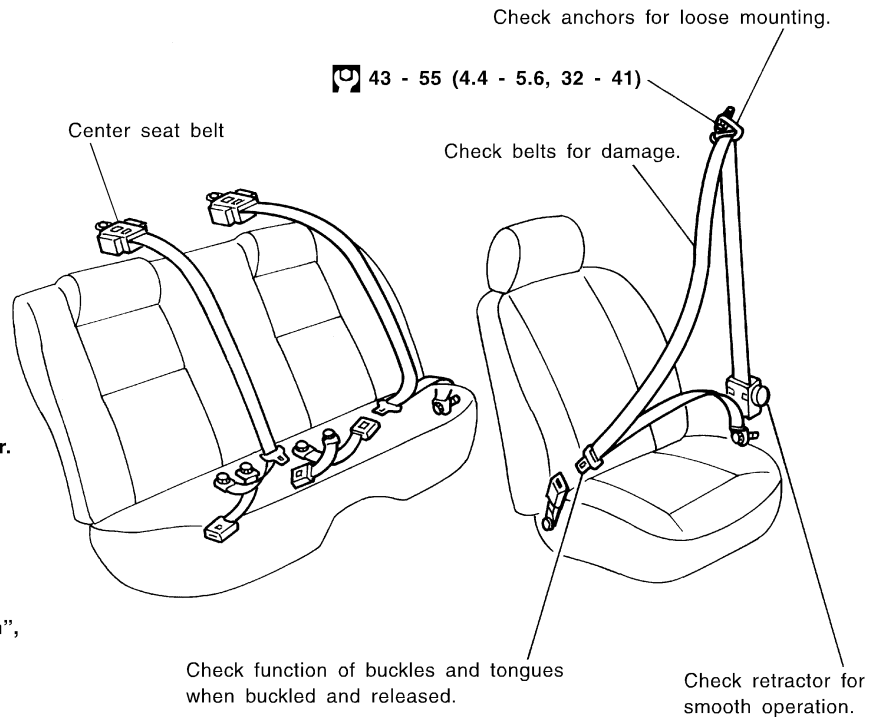

SMA024DA

Engine Maintenance

INSPECTION AND ADJUSTMENT

Belt deflection and tension

	Deflection adjustment Unit: mm (in)			Tension adjustment*1 Unit: N (kg, lb)		
	Used belt		New belt	Used belt		New belt
	Limit	After adjustment		Limit	After adjustment	
Alternator	8 (0.31)	4 - 5 (0.16 - 0.20)	3.5 - 4.5 (0.138 - 0.177)	196 (20, 44)	736 - 814 (75 - 83, 165 - 183)	843 - 922 (86 - 94, 190 - 207)
Air conditioner compressor	13 (0.51)	9 - 10 (0.35 - 0.39)	8 - 9 (0.31 - 0.35)	196 (20, 44)	500 - 579 (51 - 59, 112 - 130)	608 - 686 (62 - 70, 137 - 154)
Power steering oil pump	14 (0.55)	9 - 10 (0.35 - 0.39)	8 - 9 (0.31 - 0.35)	137 (14, 31)	353 - 432 (36 - 44, 79 - 97)	451 - 530 (46 - 54, 101 - 119)
Water pump	9 (0.35)	6 - 7 (0.24 - 0.28)	5 - 6 (0.20 - 0.24)	196 (20, 44)	539 - 618 (55 - 63, 121 - 139)	657 - 736 (67 - 75, 148 - 165)
Applied pushing force	98 N (10 kg, 22 lb)			—		

*1: If the belt tension gauge cannot be installed at check points, check drive belt tension at a different location on the belt.

Spark plug

Standard type	PFR5G-11
Hot type	PFR4G-11
Cold type	PFR6G-11
Plug gap (Nominal)	1.1 mm (0.043 in)

Chassis and Body Maintenance

INSPECTION AND ADJUSTMENT

Wheel balance

Maximum allowable unbalance	Dynamic (at rim flange) g (oz)	10 (0.35) (One side)
	Static g (oz)	20 (0.71)

GI

MA

EM

LC

EC

FE

AT

PD

FA

RA

BR

ST

RS

BT

HA

EL

IDX

NOTES