

A
CO
C
D
E
F
G
H
I
J
K
L
M

CO

SECTION

ENGINE COOLING SYSTEM

CONTENTS

<p>PRECAUTIONS 2</p> <p style="padding-left: 20px;">Precautions for Supplemental Restraint System (SRS) "AIR BAG" and "SEAT BELT PRE-TENSIONER" 2</p> <p style="padding-left: 20px;">Precautions for Liquid Gasket 2</p> <p style="padding-left: 40px;">REMOVAL OF LIQUID GASKET SEALING 2</p> <p style="padding-left: 40px;">LIQUID GASKET APPLICATION PROCEDURE.... 2</p> <p>PREPARATION 4</p> <p style="padding-left: 20px;">Special Service Tools 4</p> <p style="padding-left: 20px;">Commercial Service Tools 4</p> <p>OVERHEATING CAUSE ANALYSIS 5</p> <p style="padding-left: 20px;">Troubleshooting Chart 5</p> <p>COOLING SYSTEM 7</p> <p style="padding-left: 20px;">Cooling Circuit 7</p> <p>ENGINE COOLANT 8</p> <p style="padding-left: 20px;">Inspection 8</p> <p style="padding-left: 40px;">LEVEL CHECK 8</p> <p style="padding-left: 40px;">LEAK CHECK 8</p> <p style="padding-left: 20px;">Changing Engine Coolant 8</p> <p style="padding-left: 40px;">DRAINING ENGINE COOLANT 8</p> <p style="padding-left: 40px;">REFILLING ENGINE COOLANT 9</p> <p style="padding-left: 40px;">FLUSHING COOLING SYSTEM 10</p> <p>RADIATOR 11</p> <p style="padding-left: 20px;">Removal and Installation 11</p> <p style="padding-left: 40px;">REMOVAL 11</p> <p style="padding-left: 40px;">INSTALLATION 12</p> <p style="padding-left: 40px;">CHECKING RADIATOR CAP 12</p> <p style="padding-left: 40px;">CHECKING RADIATOR 12</p>	<p>RADIATOR (ALUMINUM TYPE) 13</p> <p style="padding-left: 20px;">Disassembly and Assembly 13</p> <p style="padding-left: 40px;">PREPARATION 13</p> <p style="padding-left: 40px;">DISASSEMBLY 13</p> <p style="padding-left: 40px;">ASSEMBLY 14</p> <p style="padding-left: 40px;">INSPECTION 16</p> <p>COOLING FAN 17</p> <p style="padding-left: 20px;">Removal and Installation 17</p> <p style="padding-left: 40px;">REMOVAL 18</p> <p style="padding-left: 40px;">INSPECTION AFTER REMOVAL 18</p> <p style="padding-left: 40px;">INSTALLATION 18</p> <p style="padding-left: 40px;">INSPECTION AFTER INSTALLATION 19</p> <p style="padding-left: 20px;">Disassembly and Assembly 19</p> <p style="padding-left: 40px;">DISASSEMBLY 19</p> <p style="padding-left: 40px;">ASSEMBLY 20</p> <p>WATER PUMP 21</p> <p style="padding-left: 20px;">Removal and Installation 21</p> <p style="padding-left: 40px;">REMOVAL 21</p> <p style="padding-left: 40px;">INSPECTION AFTER REMOVAL 22</p> <p style="padding-left: 40px;">INSTALLATION 22</p> <p style="padding-left: 40px;">INSPECTION AFTER INSTALLATION 22</p> <p>THERMOSTAT AND WATER CONTROL VALVE ... 23</p> <p style="padding-left: 20px;">Removal and Installation 23</p> <p style="padding-left: 40px;">REMOVAL 23</p> <p style="padding-left: 40px;">INSPECTION AFTER REMOVAL 24</p> <p style="padding-left: 40px;">INSTALLATION 24</p> <p>SERVICE DATA AND SPECIFICATIONS (SDS) 25</p> <p style="padding-left: 20px;">Standard and Limit 25</p> <p style="padding-left: 40px;">CAPACITY 25</p> <p style="padding-left: 40px;">THERMOSTAT 25</p> <p style="padding-left: 40px;">WATER CONTROL VALVE 25</p> <p style="padding-left: 40px;">RADIATOR 25</p> <p style="padding-left: 20px;">Tightening Torque 25</p>
---	---

PRECAUTIONS

PRECAUTIONS

PF0:00001

Precautions for Supplemental Restraint System (SRS) “AIR BAG” and “SEAT BELT PRE-TENSIONER”

EBS003D6

The Supplemental Restraint System such as “AIR BAG” and “SEAT BELT PRE-TENSIONER”, used along with a front seat belt, helps to reduce the risk or severity of injury to the driver and front passenger for certain types of collision. Information necessary to service the system safely is included in the SRS and SB section of this Service Manual.

WARNING:

- To avoid rendering the SRS inoperative, which could increase the risk of personal injury or death in the event of a collision which would result in air bag inflation, all maintenance must be performed by an authorized NISSAN/INFINITI dealer.
- Improper maintenance, including incorrect removal and installation of the SRS, can lead to personal injury caused by unintentional activation of the system. For removal of Spiral Cable and Air Bag Module, see the SRS section.
- Do not use electrical test equipment on any circuit related to the SRS unless instructed to in this Service Manual. SRS wiring harnesses can be identified by yellow and/or orange harnesses or harness connectors.

Precautions for Liquid Gasket REMOVAL OF LIQUID GASKET SEALING

EBS0024Y

- After removing the mounting bolts and nuts, separate the mating surface using a seal cutter and remove the liquid gasket sealing.

CAUTION:

Be careful not to damage the mating surfaces.

- In areas where the cutter is difficult to use, use a plastic hammer to lightly tap the area where the liquid gasket is applied.

CAUTION:

If for some unavoidable reason a tool such as a flat-bladed screwdriver is used, be careful not to damage the mating surfaces.

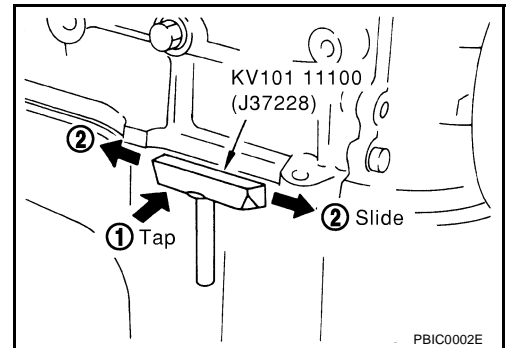

LIQUID GASKET APPLICATION PROCEDURE

1. Using a scraper, remove the old liquid gasket adhering to the gasket application surface and the mating surface.
 - Remove the liquid gasket completely from the groove of the gasket application surface, mounting bolts, and bolt holes.
2. Wipe the gasket application surface and the mating surface with white gasoline (lighting and heating use) to remove adhering moisture, grease and foreign materials.
3. Attach the liquid gasket to the tube presser.
Use Genuine Ultra Grey RTV Silicone Sealant Part No. 999MP-AM003P or equivalent.
4. Apply the gasket without breaks to the specified location with the specified dimensions.
 - If there is a groove for the liquid gasket application, apply the gasket to the groove.

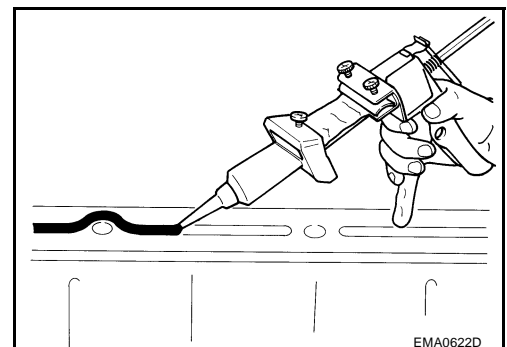
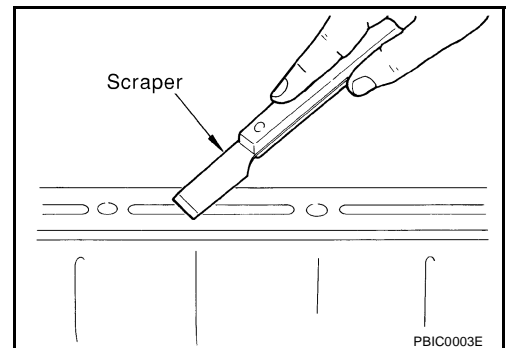

PRECAUTIONS

- As for the bolt holes, normally apply the gasket inside the holes. Occasionally, it should be applied outside the holes. Make sure to read the text of service manual.
- Within five minutes of gasket application, install the mating component.
- If the liquid gasket protrudes, wipe it off immediately.
- Do not retighten after the installation.
- After 30 minutes or more have passed from the installation, fill the engine oil and coolant.

CAUTION:

If there are specific instructions in this manual, observe them.

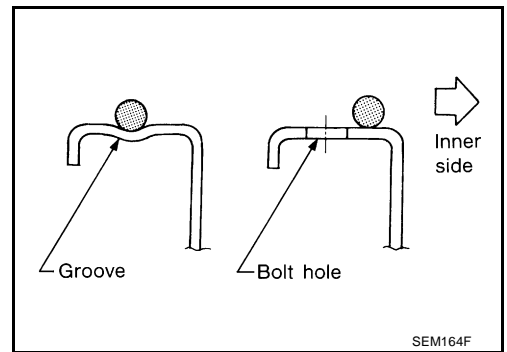

A

CO

C

D

E

F

G

H

I

J

K

L

M

PREPARATION

PREPARATION

PFP:00002

Special Service Tools

EBS00256

The actual shapes of Kent-Moore tools may from those of special service tools illustrated here.

Tool number (Kent-Moore No.) Tool name	Description
WS39930000 (-) Tube pressure	Pressing the tube of liquid gasket
EG17650301 (J33984-A) Radiator cap tester adapter	Adapting radiator cap tester to radiator cap and radiator filler neck a: 28 (1.10) dia. b: 31.4 (1.236) dia. c: 41.3 (1.626) dia. Unit: mm (in)
KV99103510 (-) Radiator plate pliers A	Installing radiator upper and lower tanks
KV99103520 (-) Radiator plate pliers B	Removing radiator upper and lower tanks

Commercial Service Tools

EBS003G1

Tool number (Kent-Moore No.) Tool name	Description
Power tool	Loosening bolts and nuts

OVERHEATING CAUSE ANALYSIS

OVERHEATING CAUSE ANALYSIS

PFP:00012

Troubleshooting Chart

EBS00257

		Symptom		Check items	
Cooling system parts malfunction	Poor heat transfer	Water pump malfunction	Worn or loose drive belt	—	—
		Thermostat stuck closed	—		
		Damaged fins	Dust contamination or paper clogging		
			Mechanical damage		
		Clogged radiator cooling tube	Excess foreign material (rust, dirt, sand, etc.)		
	Reduced air flow	Cooling fan does not operate	—	—	
		High resistance to fan rotation			
		Damaged fan blades			
		Damaged radiator shroud	—	—	—
		Improper coolant mixture ratio	—	—	—
		Poor coolant quality	—	—	—
	Insufficient coolant	Coolant leaks	Cooling hose	Loose clamp	
				Cracked hose	
			Water pump	Poor sealing	
			Radiator cap	Loose	
Poor sealing					
Radiator		O-ring for damage, deterioration or improper fitting			
		Cracked radiator tank			
		Cracked radiator core			
	Reservoir tank	Cracked reservoir tank			
Overflowing reservoir tank	Exhaust gas leaks into cooling system	Cylinder head deterioration			
		Cylinder head gasket deterioration			

A
CO
C
D
E
F
G
H
I
J
K
L
M

OVERHEATING CAUSE ANALYSIS

		Symptom		Check items				
Except cooling system parts malfunction	—	Overload on engine	Abusive driving	High engine rpm under no load	—			
				Driving in low gear for extended time				
				Driving at extremely high speed				
			Powertrain system malfunction	—				
			Installed improper size wheels and tires					
			Dragging brakes					
			Improper ignition timing					
			Blocked or restricted air flow	Blocked or restricted air flow		Blocked bumper	—	—
						Blocked radiator grille	Installed car brassiere	
							Mud contamination or paper clogging	
Blocked radiator	—							
Blocked condenser	—							
Installed large fog lamp								

COOLING SYSTEM

COOLING SYSTEM

PFP:21020

Cooling Circuit

EBS001KG

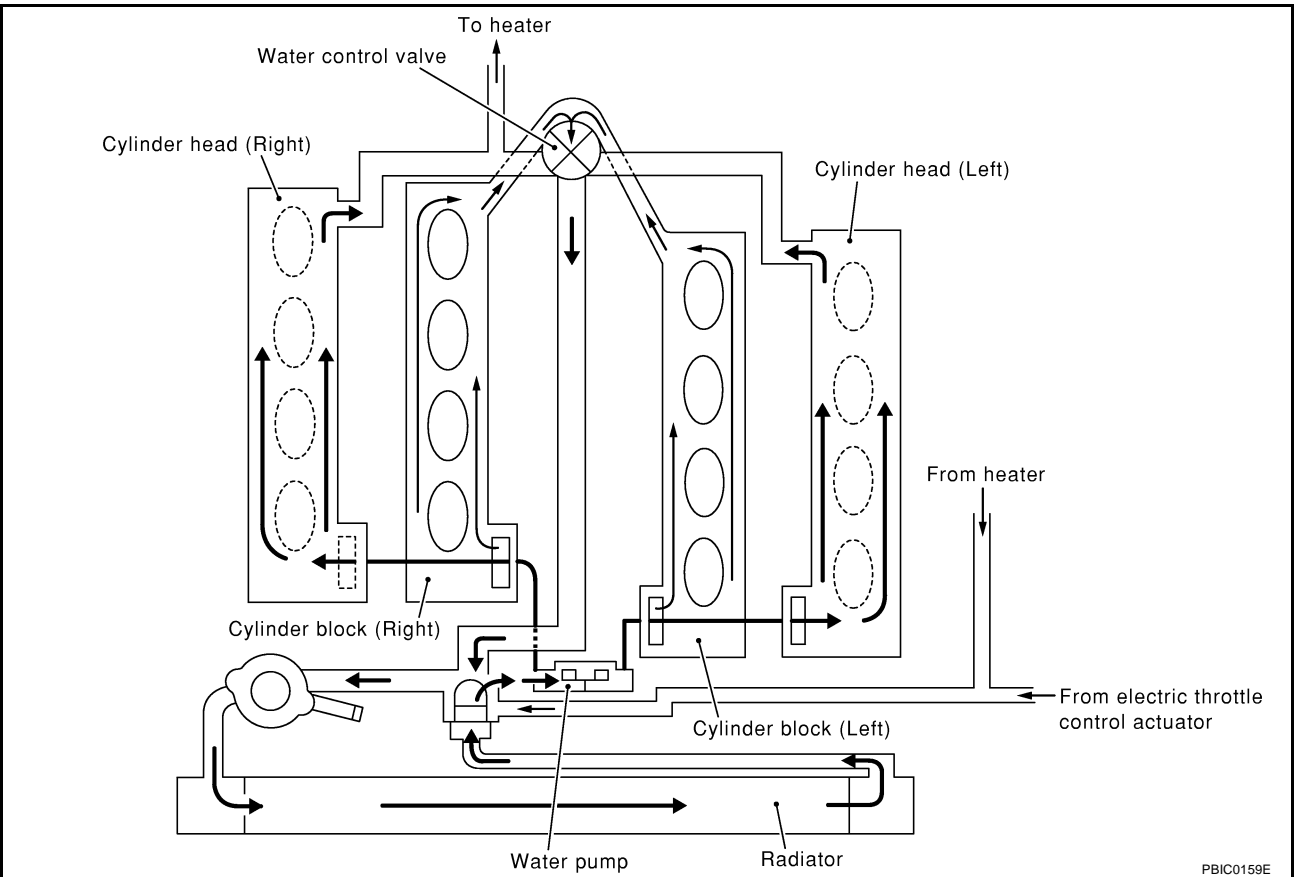

PBIC0159E

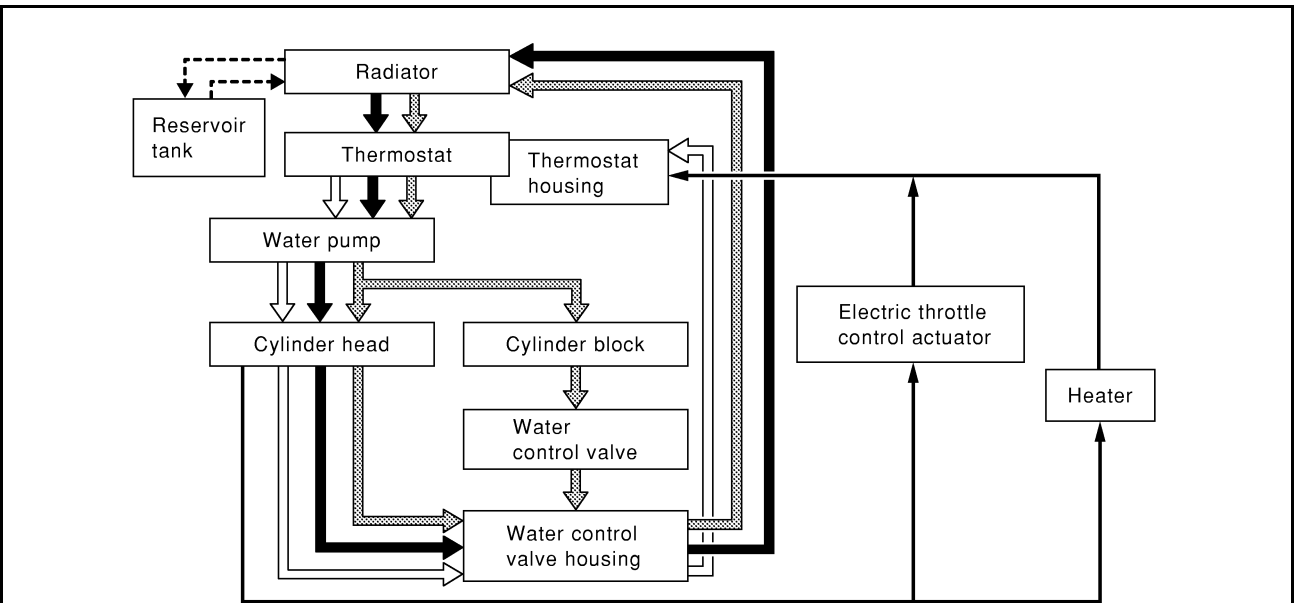

	Thermostat	Water control valve
	Closed	Closed
	Open	Closed
	Open	Open

PBIC0160E

A
CO
C
D
E
F
G
H
I
J
K
L
M

ENGINE COOLANT

ENGINE COOLANT

PFP:KQ100

Inspection LEVEL CHECK

EBS001KH

- Check if the reservoir tank coolant level within MIN to MAX When engine cool.
- Adjust coolant if too much or too little.

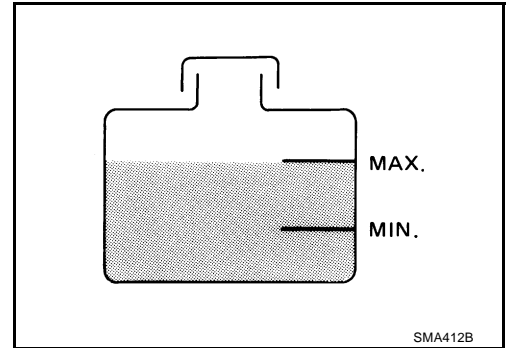

LEAK CHECK

- To check for leakage, apply pressure to the cooling system with a tester.

Testing pressure:

157 kPa (1.6 kg/cm² , 23 psi)

WARNING:

Never remove the radiator cap when the engine is hot. Serious burns could occur from high pressure coolant escaping from the radiator.

CAUTION:

Higher pressure than specified may cause radiator damage.

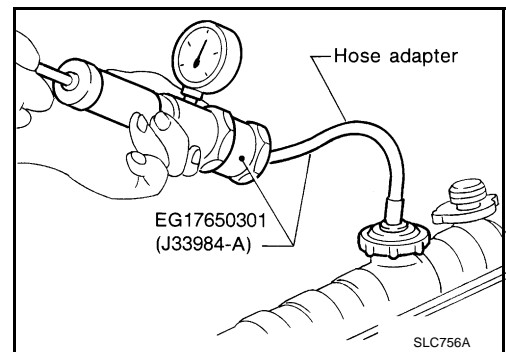

Changing Engine Coolant

EBS00250

WARNING:

- To avoid being scalded, never change the coolant when the engine is hot.
- Wrap a thick cloth around cap and carefully remove the cap. First, turn the cap a quarter of a turn to release built-up pressure. Then turn the cap all the way.

DRAINING ENGINE COOLANT

1. Remove under cover with power tool.
2. Open radiator drain plug at the bottom of radiator, and remove radiator cap.
- **Be careful not to allow coolant to contact drive belts.**

When draining all the coolant in the system, also perform the following steps.

3. Remove air relief plug on heater hose.

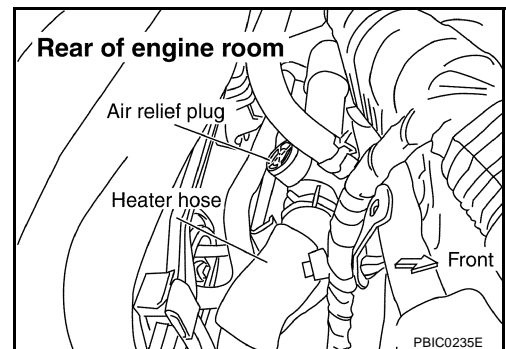

ENGINE COOLANT

4. Drain coolant from both sides of cylinder block when draining all the coolant in the system.

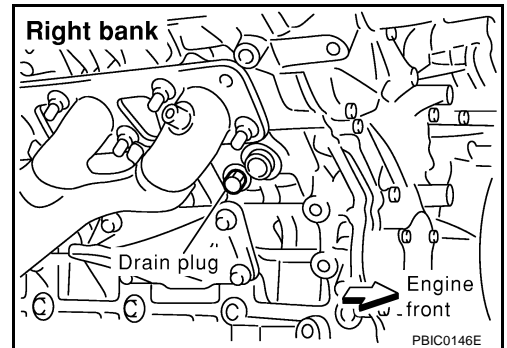
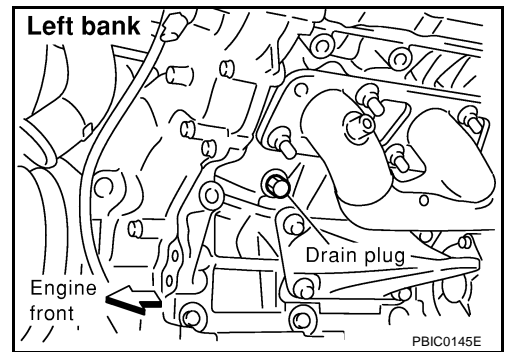

5. Check drained coolant for contaminants such as rust, corrosion or discoloration. If contaminated, flush engine cooling system. Refer to [CO-10, "FLUSHING COOLING SYSTEM"](#).
6. Remove reservoir tank, drain coolant, then clean reservoir tank.

REFILLING ENGINE COOLANT

1. Install reservoir tank if removed, and radiator drain plug.
2. Install cylinder block drain plugs if removed.

Apply sealant to the thread of cylinder block drain plugs.

- Use Genuine Thread Sealant Part No. 999MP-AM002P or equivalent.

 : 14.7 - 24.5 N-m (1.5 - 2.5 kg-m , 11 - 18 ft-lb)

3. Fill radiator and reservoir tank to specified level.
- Use genuine Nissan anti-freeze coolant or equivalent mixed with water (distilled or demineralized). Refer to [MA-10, "RECOMMENDED FLUIDS AND LUBRICANTS"](#).

Engine coolant capacity (With reservoir tank):

Approximately 9.8 l (10-3/8 US qt, 8-5/8 Imp qt)

Reservoir tank capacity:

0.8 l (7/8 US qt, 3/4 Imp qt)

- Pour coolant through coolant filler neck slowly of less than 2 l (2-1/8 US qt, 1-3/4 Imp qt) a minute to allow air in system to escape.
 - When coolant overflows air relief hole on heater hose, install air relief plug.
4. Warm up engine to normal operating temperature with radiator cap installed.

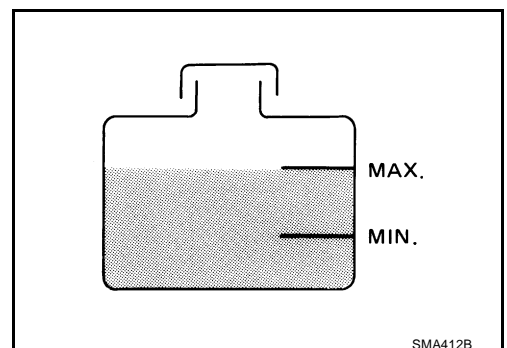
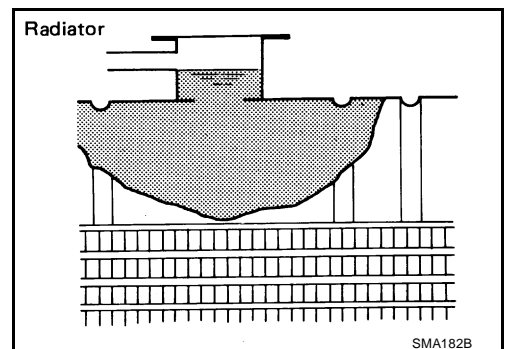

ENGINE COOLANT

5. Run engine at 3,000 rpm for 10 seconds and return to idle speed.

- Repeat two or three times.

Watch coolant temperature gauge so as not to overheat the engine.

6. Stop engine and cool down to less than approximately 50°C (122°F).

- Cool down using a fan to reduce the time.
- If necessary, refill radiator up to filler neck with coolant.

7. Refill reservoir tank to MAX level line with coolant.

8. Repeat steps 4 through 6 two or more times with radiator cap installed until coolant level no longer drops.

9. Check cooling system for leaks with engine running.

10. Warm up engine, and check for sound of coolant flow while running engine from idle up to 3,000 rpm with heater temperature controller set at several position between COOL and WARM.

- Sound may be noticeable at heater unit.

11. Repeat step 9 three times.

12. If sound is heard, bleed air from cooling system by repeating steps 4 through 6 until coolant level no longer drops.

- **Clean excess coolant from engine.**

FLUSHING COOLING SYSTEM

1. Fill radiator with water until water spills from the air relief hole, then close air relief plug. Fill radiator and reservoir tank with water and reinstall radiator cap.

2. Run engine and warm it up to normal operating temperature.

3. Rev engine two or three times under no-load.

4. Stop engine and wait until it cools down.

5. Drain water.

6. Repeat steps 1 through 5 until clear water begins to drain from radiator.

RADIATOR

PFP:21400

EBS001KJ

RADIATOR

Removal and Installation

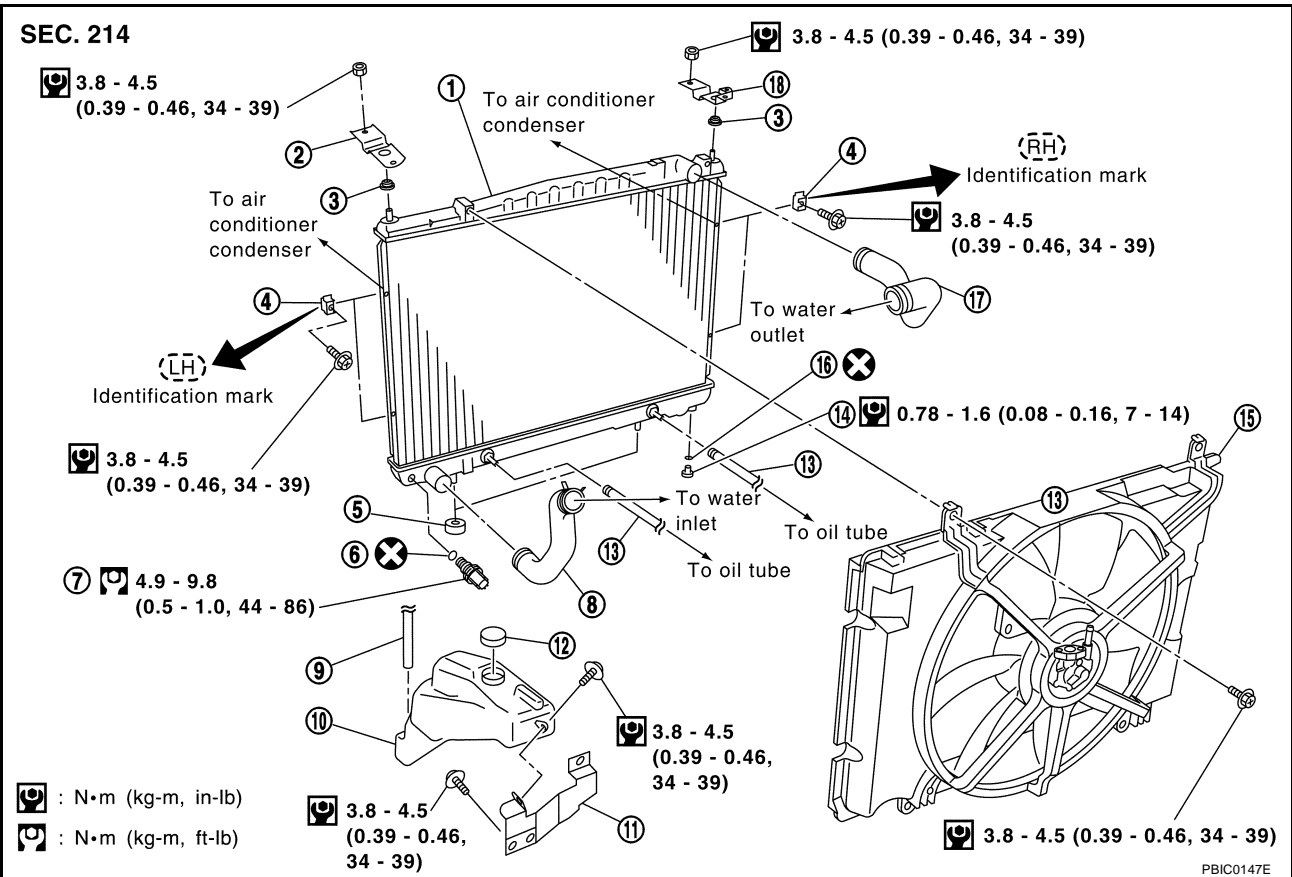

- | | | |
|--|---------------------------|------------------------|
| 1. Radiator | 2. Bracket | 3. Mounting rubber |
| 4. Clip | 5. Mounting rubber | 6. O-ring |
| 7. Radiator coolant temperature sensor | 8. Radiator hose (lower) | 9. Reservoir tank hose |
| 10. Reservoir tank | 11. Bracket | 12. Cap |
| 13. A/T oil cooler hose | 14. Drain plug | 15. Cooling fan shroud |
| 16. O-ring | 17. Radiator hose (upper) | 18. Bracket |

WARNING:

Never remove the radiator cap when the engine is hot. Serious burns could occur from high pressure coolant escaping from the radiator.

REMOVAL

1. Drain coolant.
 - CAUTION:** Perform when the engine is cold.
2. Remove cooling fan shroud. Refer to [CO-17, "Removal and Installation"](#).
3. Remove A/T oil cooler hoses.
 - Install blind plug to void leakage of A/T fluid.
4. Remove bolts of both right/left end of radiator core (2 bolts for each).

RADIATOR

- Lift the air condenser up approximately 2 cm (0.79 in). Remove the clips from the right and left flange parts of the condenser.

CAUTION:

To avoid putting a load on the air conditioner piping, be careful not to lift too much.

- Lift up and remove the radiator.

CAUTION:

- Do not damage or scratch radiator core when removing.
- After removing the radiator, fix the air condenser on the vehicle side with a rope or similar means. This is to prevent a load being applied to the air conditioner piping.

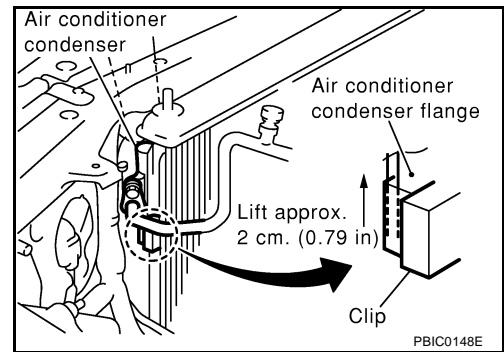

INSTALLATION

- Install in the reverse order of removal.
- Align ID marks to install clips of both right/left end of radiator core. Refer to Radiator component illustration on top page.

CHECKING RADIATOR CAP

- Pull the negative pressure valve to open it and check that it close completely when released.
 - Check that there is no dirt or damage on the valve seat of the radiator cap negative-pressure valve.
 - Check that there are no abnormalities in the opening and closing conditions of the negative-pressure valve.

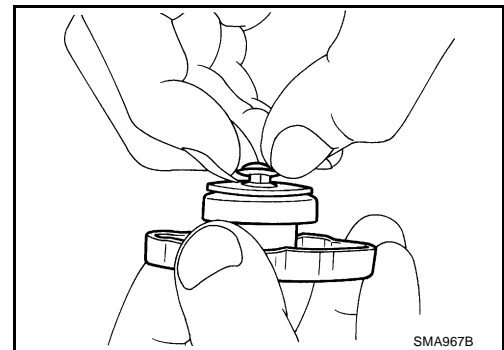

- Check radiator cap relief pressure.

Standard : 78 - 98 kPa (0.8 - 1.0 kg/cm² , 11 - 14 psi)

Limit : 59 kPa (0.6 kg/cm² , 9 psi)

- When connecting the radiator cap to the tester, apply water or LLC to the cap seal part.
- Replace the radiator cap if there is an abnormality in the negative-pressure valve, or if the open-valve pressure is outside of the standard values.

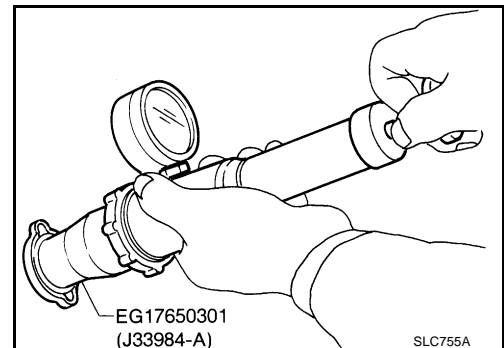

CHECKING RADIATOR

Check radiator for mud or clogging. If necessary, clean radiator as follows.

- Be careful not to bend or damage the radiator fins.
 - When radiator is cleaned without removal, remove all surrounding parts such as cooling fan shroud and horns. Then tape the harness and connectors to prevent water from entering.
- Apply water by hose to the back side of the radiator core vertically download.
 - Apply water again to all radiator core surfaces once per minute.
 - Stop washing if any stains no longer flow out from the radiator.
 - Blow air into the back side of radiator core vertically download.
- Use compressed air lower than 490 kPa (5 kg/cm² , 71 psi) and keep distance more than 30 cm (11.8 in).
- Blow air again into all the radiator core surfaces once per minute until no water sprays out.

RADIATOR (ALUMINUM TYPE)

RADIATOR (ALUMINUM TYPE)

PPF:21460

Disassembly and Assembly

EBS003P4

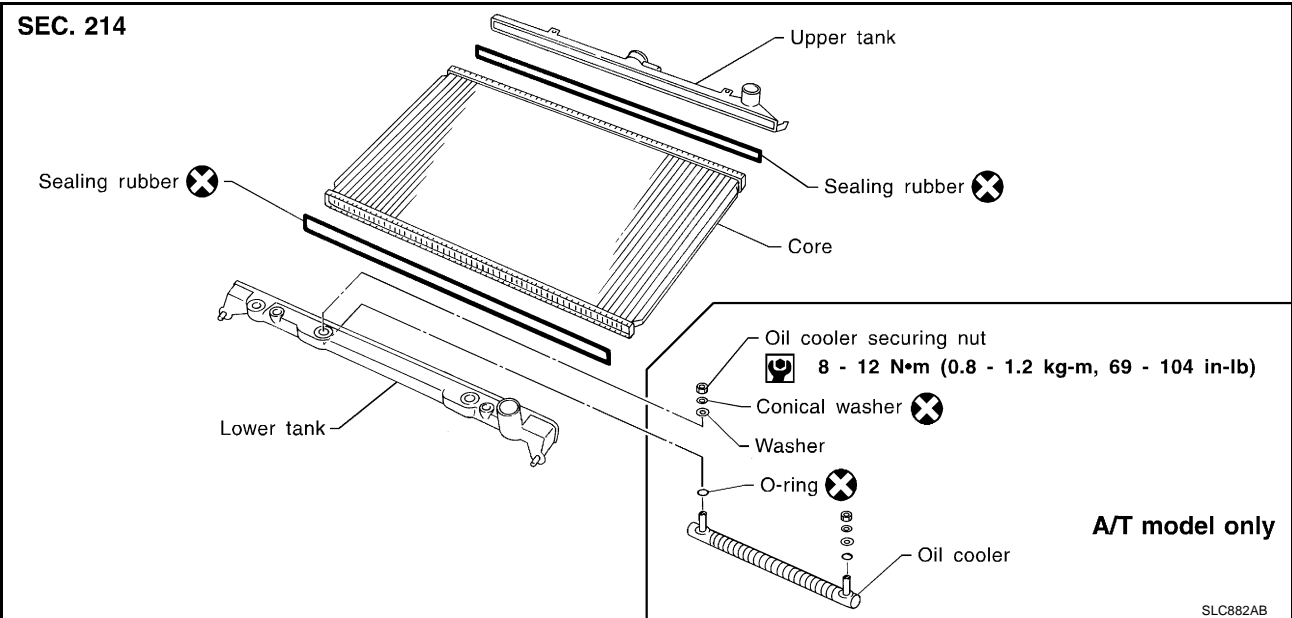

PREPARATION

1. Attach the spacer to the tip of the radiator plate pliers A. Spacer specification: 1.5 mm (0.059 in) thick x 18 mm (0.71 in) wide x 8.5 mm (0.335 in) long.
2. Make sure that when radiator plate pliers A are closed dimension H'' is approx. 7.6 mm (0.299 in).
3. Adjust dimension H'' with the spacer, if necessary.

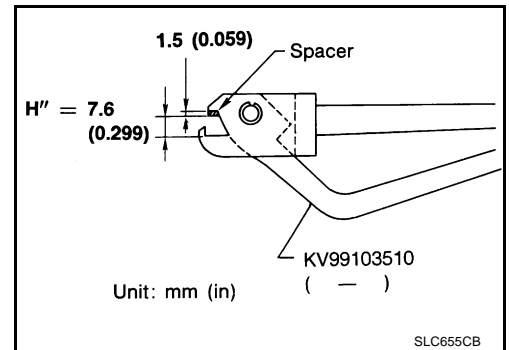

DISASSEMBLY

1. Remove tank with Tool.

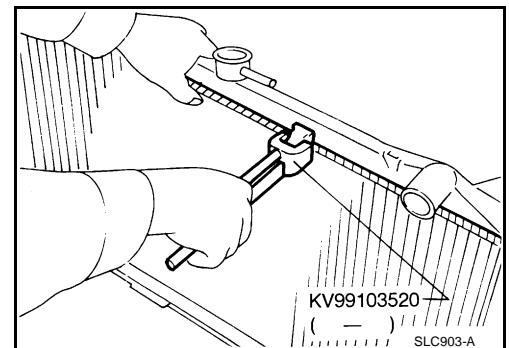

RADIATOR (ALUMINUM TYPE)

- Grip the crimped edge and bend it upwards so that Tool slips off.
Do not bend excessively.

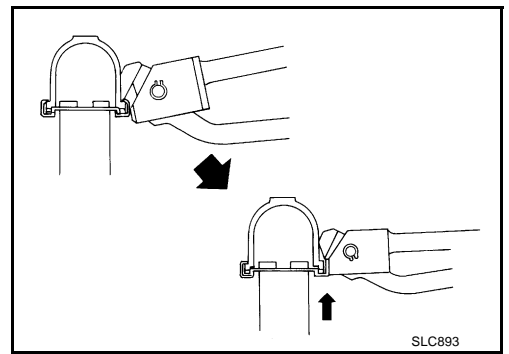

- In areas where Tool cannot be used, use a screwdriver to bend the edge up.
Be careful not to damage tank.

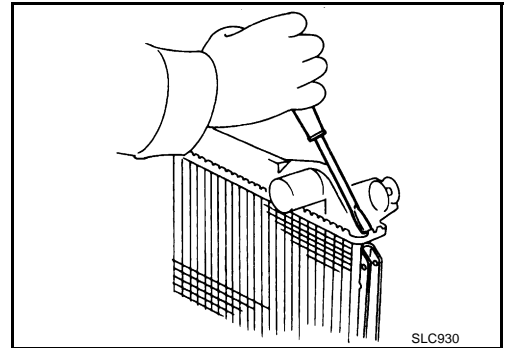

2. Make sure the edge stands straight up.
3. Remove oil cooler from tank. (A/T model only)

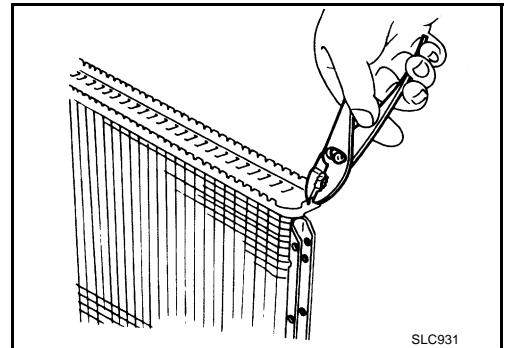

ASSEMBLY

1. Install oil cooler. (A/T model only)
Pay attention to direction of conical washer.

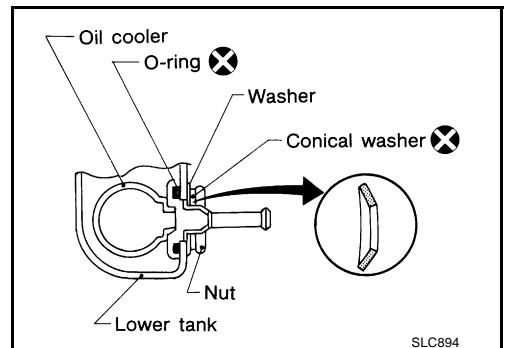

RADIATOR (ALUMINUM TYPE)

2. Clean contact portion of tank.

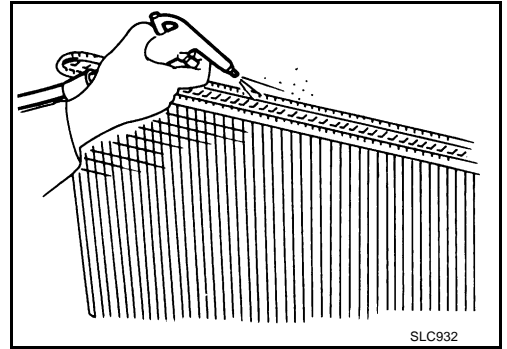

3. Install sealing rubber.
Push it in with fingers.
Be careful not to twist sealing rubber.

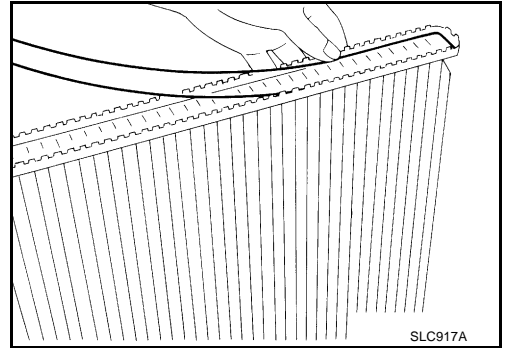

4. Caulk tank in specified sequence with Tool.

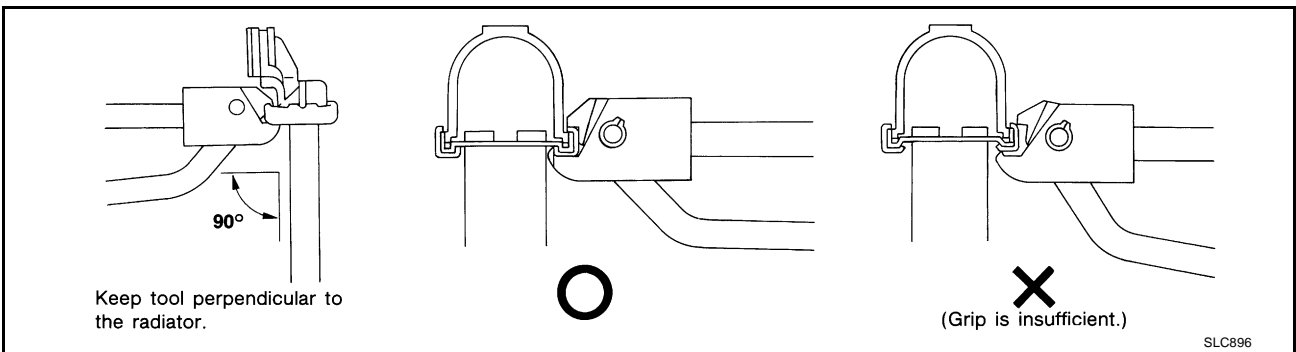
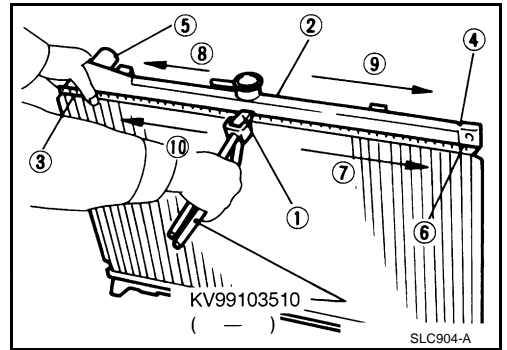

● Use pliers in the locations where Tool cannot be used.

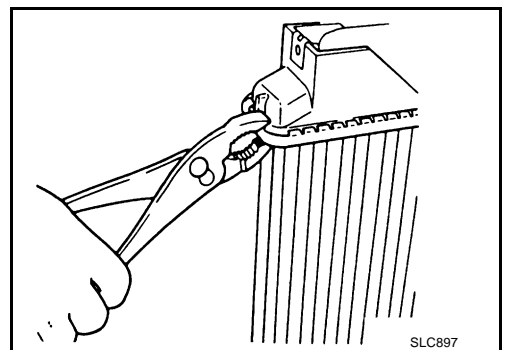

A
 CO
 C
 D
 E
 F
 G
 H
 I
 J
 K
 L
 M

RADIATOR (ALUMINUM TYPE)

5. Make sure that the rim is completely crimped down.

Standard height "H" : 8.0 - 8.4 mm (0.315 - 0.331 in)

6. Confirm that there is no leakage.

Refer to Inspection.

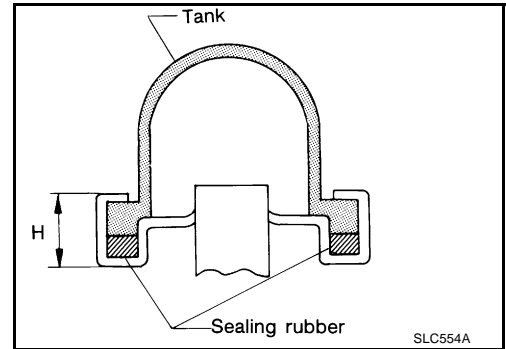

INSPECTION

1. Apply pressure with Tool.

Specified pressure value:

157 kPa (1.57 bar, 1.6 kg/cm² , 23 psi)

WARNING:

To prevent the risk of the hose coming undone while under pressure, securely fasten it down with a hose clamp. Attach a hose to the oil cooler as well. (A/T model only)

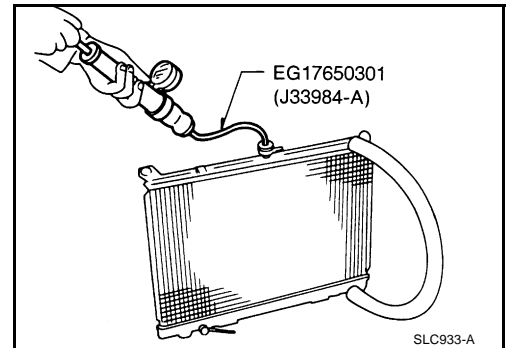

2. Check for leakage.

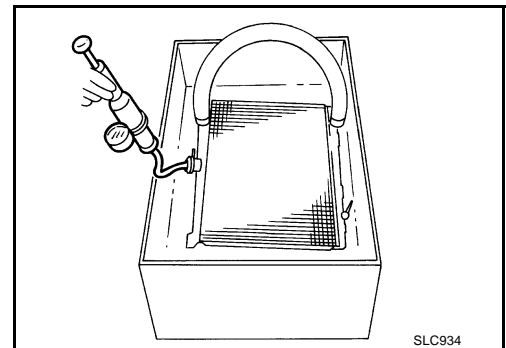

COOLING FAN

COOLING FAN

PFP:21140

Removal and Installation

EBS00204

A
CO
C
D
E
F
G
H
I
J
K
L
M

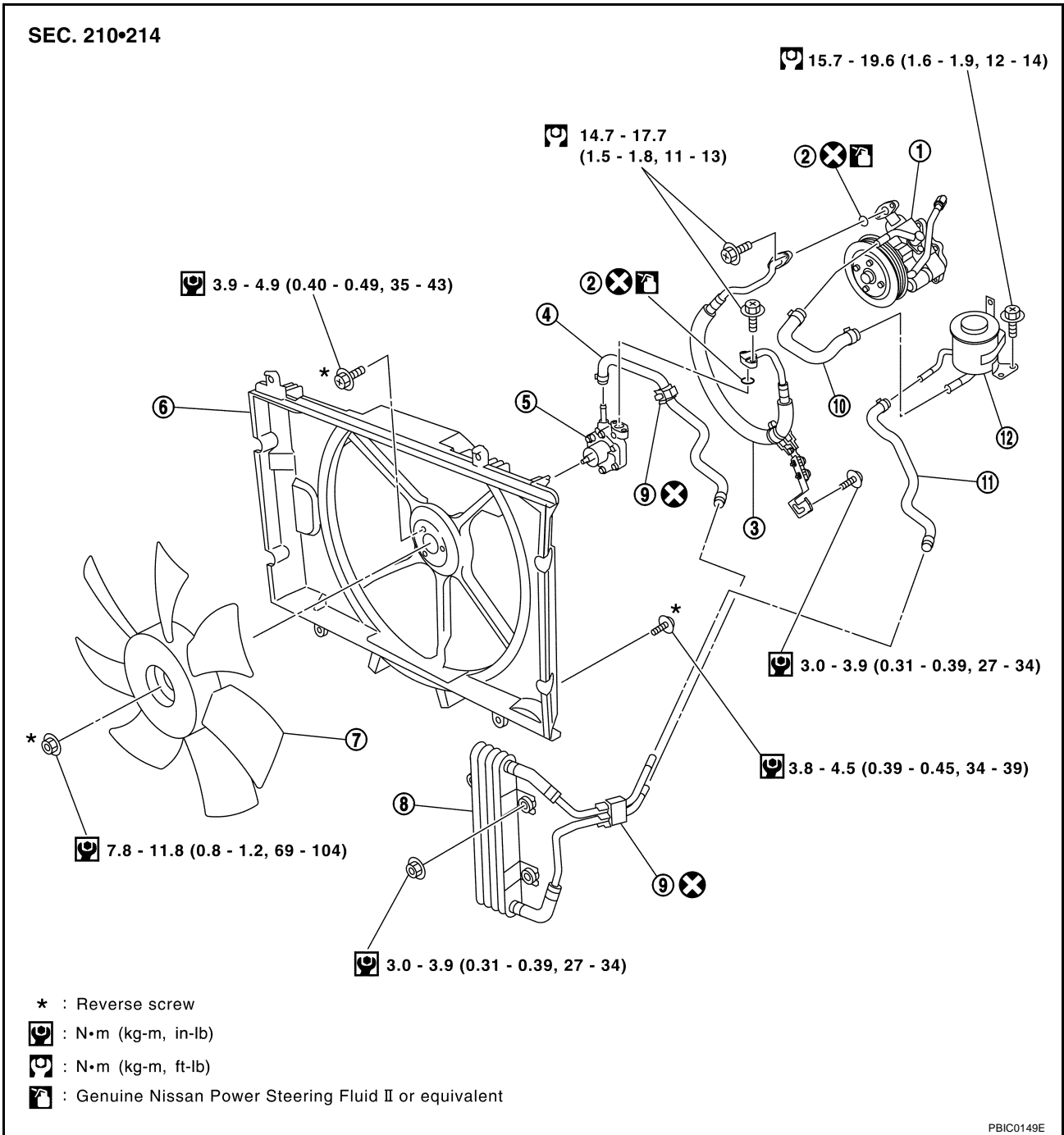

- | | | |
|--|---|-----------------------|
| 1. Cooling fan pump (with water pump)
(Do not disassemble.) | 2. O-ring | 3. Fluid hose |
| 4. Fluid hose | 5. Cooling fan motor
(Do not disassemble.) | 6. Cooling fan shroud |
| 7. Fan | 8. Cooling fan fluid cooler | 9. Clip |
| 10. Fluid hose | 11. Fluid hose | 12. Reservoir tank |

COOLING FAN

REMOVAL

1. Remove air duct and air cleaner case. Refer to [EM-15, "Removal and Installation"](#) .
2. Remove under cover with power tool.
3. Drain coolant. Refer to [CO-8, "Changing Engine Coolant"](#) .

CAUTION:

- Perform when the engine is cold.
 - Never remove the radiator cap when the engine is hot. Serious burns could occur from high pressure fluid escaping from the radiator.
4. Remove battery.
 5. Remove the vacuum tank from the front of the engine.
 6. Disconnect the radiator hoses (upper/lower).
 7. Remove the following parts from the fan shroud: coolant temperature sensor harness, coolant reservoir tank hose, A/T oil cooler hose, mounting bolts for the cooling fan fluid hose bracket.
 8. Drain the cooling fan fluid.
 - Because there is no drain plug on the reservoir tank or piping, drain the fluid from the reservoir tank oil inlet and pipe division points.
 - Prepare a container with a volume of approximately 1 ℓ (2-1/8 US pt, 1-3/4 Imp pt) to drain the fluid into.
 9. Remove the cooling fan fluid reservoir tank.
 10. Disconnect the hoses between the cooling fan motor and cooling fan pump (joined with the water pump), and the hose between the cooling fan motor and the oil cooler.
 - Fluid will leak, so have shop cloths ready.
 11. Remove the cooling fan shroud mounting bolts.
 12. Remove the radiator mounting bracket. With the radiator moved toward the vehicle front, lift up and remove the cooling fan.

CAUTION:

- Be careful not to scratch or damage the radiator core.
- When removing the cooling fan pump, remove it together with the water pump. (They can not be separated.) Refer to [CO-21, "Removal and Installation"](#) .
- When removing the cooling fan fluid cooler, be careful not to scratch or damage the air conditioner condenser core.

INSPECTION AFTER REMOVAL

- Turning oil cooling fan motor shaft by hands check if it rotates smoothly without looseness.
- Check visually for fluid leakage from cooling fan motor.
- For oil pump inspection, refer to [CO-21, "WATER PUMP"](#) .

INSTALLATION

Install in the reverse order of removal referring the following.

- For bleeding the air from the cooling system. Refer to [CO-9, "REFILLING ENGINE COOLANT"](#) .

Attaching the fluid pipe fixing clip

- If the fluid pipe fixing clip has been removed from the installation holes, it must be replaced with a new clip.

Adding cooling fan fluid and bleeding air

- The procedure below is for adding cooling fan fluid and bleeding air from the piping.

CAUTION:

Do not reuse the used fluid which was drained out.

Use genuine Nissan Power Steering Fluid II or equivalent. Refer to [MA-10, "RECOMMENDED FLUIDS AND LUBRICANTS"](#) .

NOTE:

The total fluid volume is 777 ml (26.3 US floz, 27.4 Imp floz) (with the cold maximum on the level gauge when the engine is cold).

1. Add fluid to the reservoir tank until the fluid reaches the upper limit of the "hot" level on the level gauge. For the fluid level, refer to [CO-19, "INSPECTION AFTER INSTALLATION"](#) .

COOLING FAN

2. Start the engine.
3. Run the engine at idle speed for a few minutes. Then check the fluid level. If the level has decreased, add fluid.

CAUTION:

- Be careful not to touch the fan while it is rotating.
- Be sure to add fluid as necessary. If the fluid runs out in the reservoir tank, air will be taken in.

NOTE:

- With the engine operating, the reservoir tank cap can be removed to check the fluid level.
 - Immediately after starting, certain noise will come from the fluid pump. This is caused by air taken in to the piping and will gradually disappear.
4. Continue with step 3 until the level of the fluid stops decreasing.
 5. Stop the engine and remove the harness connector for the cooling fan control solenoid.

NOTE:

When the solenoid harness is disconnected, the fan will operate at full speed.

6. Start the engine. Repeat step 3 until the fluid level stops decreasing and air bubbles stop coming out.
7. Stop the engine. Connect the harness connector for the cooling fan control solenoid.

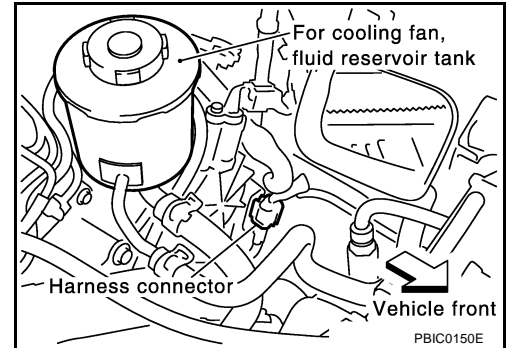

INSPECTION AFTER INSTALLATION

- Check that there is no fluid leakage from any hose connection or any other part.
- Check the fluid level with the level gauge on the reservoir tank cap. If there is too much or too little, adjust the amount of fluid.
- Check that under the fluid temperature conditions below, the fluid level is within the "cold" or "hot" range on the level gauge.

Cold : Fluid temperature 0 - 30 °C (32 - 86 °F)

Hot : Fluid temperature 50 - 80 °C (122 - 176 °F)

NOTE:

- There is no specified timing for replacing the fluid.
- Refer to [EC-534, "DTC P1480 COOLING FAN SPEED CONTROL SOLENOID VALVE \(CIRCUIT\)"](#) for control of cooling fan.

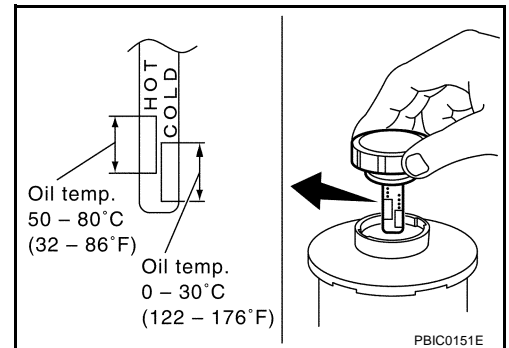

Disassembly and Assembly

DISASSEMBLY

1. Remove fan.

CAUTION:

- Reverse screws are used for the fan attachment nuts. When removing or attaching, turn the nut the opposite way as for a normal screw.
- Do not remove the balancer clip from the fan.
- For the case if the balancer clip is removed, make an alignment mark for the installation position on the fan side.

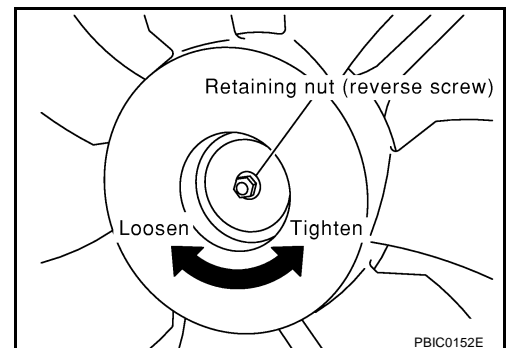

EBS0037K

A
CO
C
D
E
F
G
H
I
J
K
L
M

COOLING FAN

2. Remove cooling fan motor from cooling fan shroud.

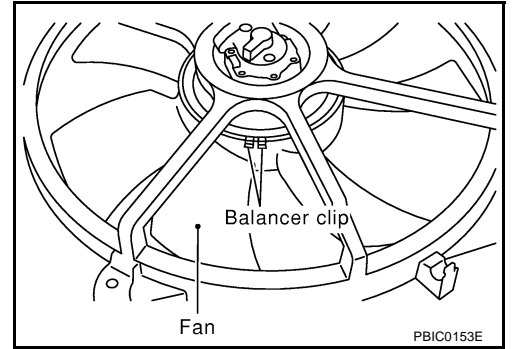

ASSEMBLY

- Assemble in the reverse order of disassembly.

WATER PUMP

WATER PUMP

PFP:21020

Removal and Installation

EBS001KN

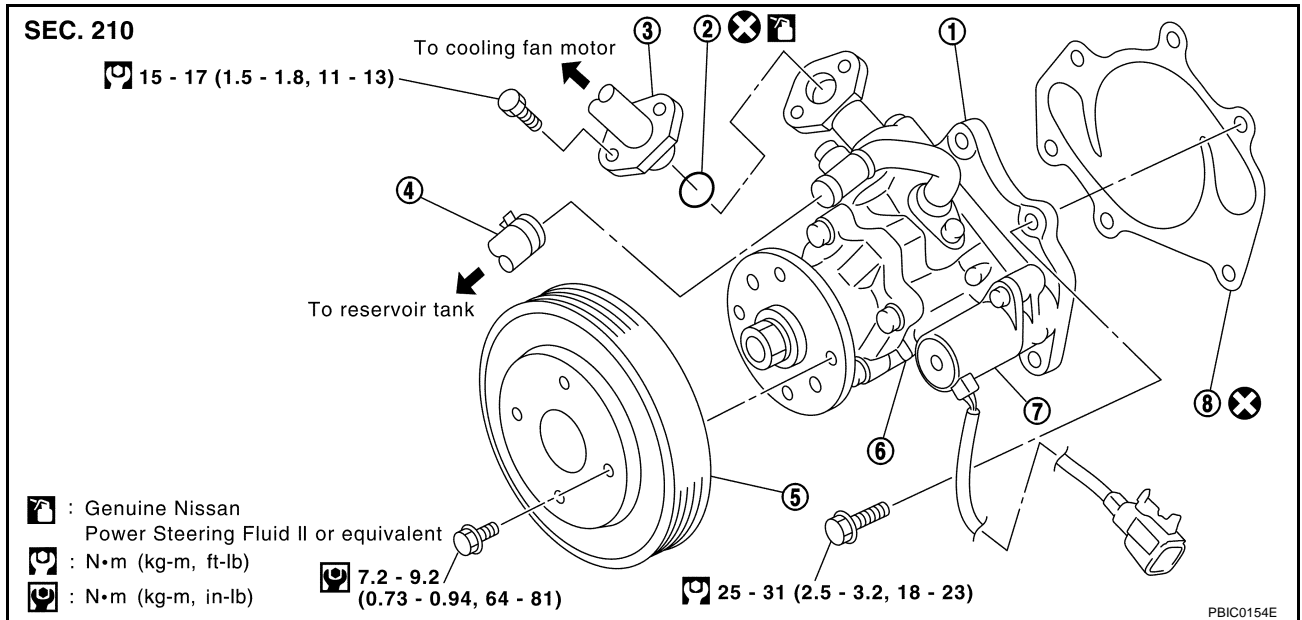

- | | | |
|--|----------------------|--|
| 1. Water pump
(Do not disassemble.) | 2. O-ring | 3. Fluid hose (feed side) |
| 4. Fluid hose (return side) | 5. Water pump pulley | 6. Cooling fan pump
(Do not disassemble.) |
| 7. Cooling fan speed control solenoid valve
(Do not disassemble.) | 8. Gasket | |

WARNING:

Never remove the radiator cap when the engine is hot. Serious burns could occur from high pressure fluid escaping from the radiator.

REMOVAL

1. Drain coolant so that no coolant comes out from water pump fitting hole.

CAUTION:

Perform when the engine is cold.

2. Remove below the parts.
 - Under cover
 - Air duct and engine room cover
For removing engine room cover, refer to [EM-11, "Removal and Installation"](#).
 - Alternator, water pump and A/C compressor belt
For removing drive belt, refer to [EM-12, "Removal and Installation"](#).

CAUTION:

Leave the fixed tensioner pulley in its fixed position when removing the drive belt.

3. Remove the harness connector for the cooling fan speed control solenoid valve (joined with the water pump).
4. Remove the drive belt pulley.
5. Disconnect the cooling fan fluid hose.
 - Because there is no drain plug, drain the fluid from the hose separation point.
 - Prepare a receptacle with a volume of approximately 1 ℓ (2-1/8 US pt, 1-3/4 Imp pt).
6. Remove the water pump.
 - Coolant will leak from the cylinder block, so have a receptacle ready below.

CAUTION:

- Handle the water pump vane so that it does not contact any other parts.

WATER PUMP

- Do not disassemble the water pump (including the cooling fan pump and cooling fan speed control solenoid).

INSPECTION AFTER REMOVAL

- Visually check that there is no significant dirt or rusting on the water pump body and vane.
- Check that there is no looseness in the vane shaft, and that it turns smoothly when rotated by hand.
- Visually check that there is no fluid leakage from the cooling fan pump part and the cooling fan speed control solenoid part.
- If there are any unusualness, replace the water pump assembly.

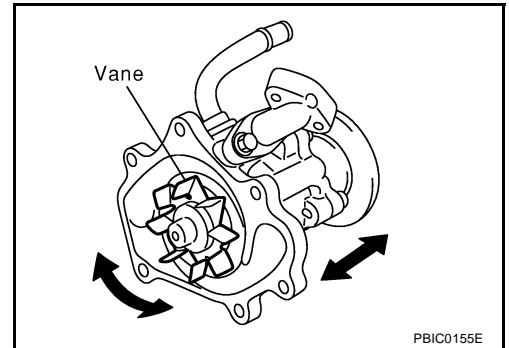

INSTALLATION

- Install in the reverse order of removal.
- Apply Genuine Nissan Power Steering Fluid II (the cooling fan fluid) or equivalent to the O-ring of the cooling fan fluid hose (on the feed side). Then insert the O-ring to the water pump so that it does not come out of the attachment groove.
- For bleeding the air from the cooling system, refer to [CO-9, "REFILLING ENGINE COOLANT"](#) .
- For bleeding the air from the cooling fan fluid, refer to [CO-18, "INSTALLATION"](#) .

INSPECTION AFTER INSTALLATION

- After installing water pump, check for leaks using radiator cap tester.

THERMOSTAT AND WATER CONTROL VALVE

PFP:21200

THERMOSTAT AND WATER CONTROL VALVE

Removal and Installation

EBS00111

A
CO
C
D
E
F
G
H
I
J
K
L
M

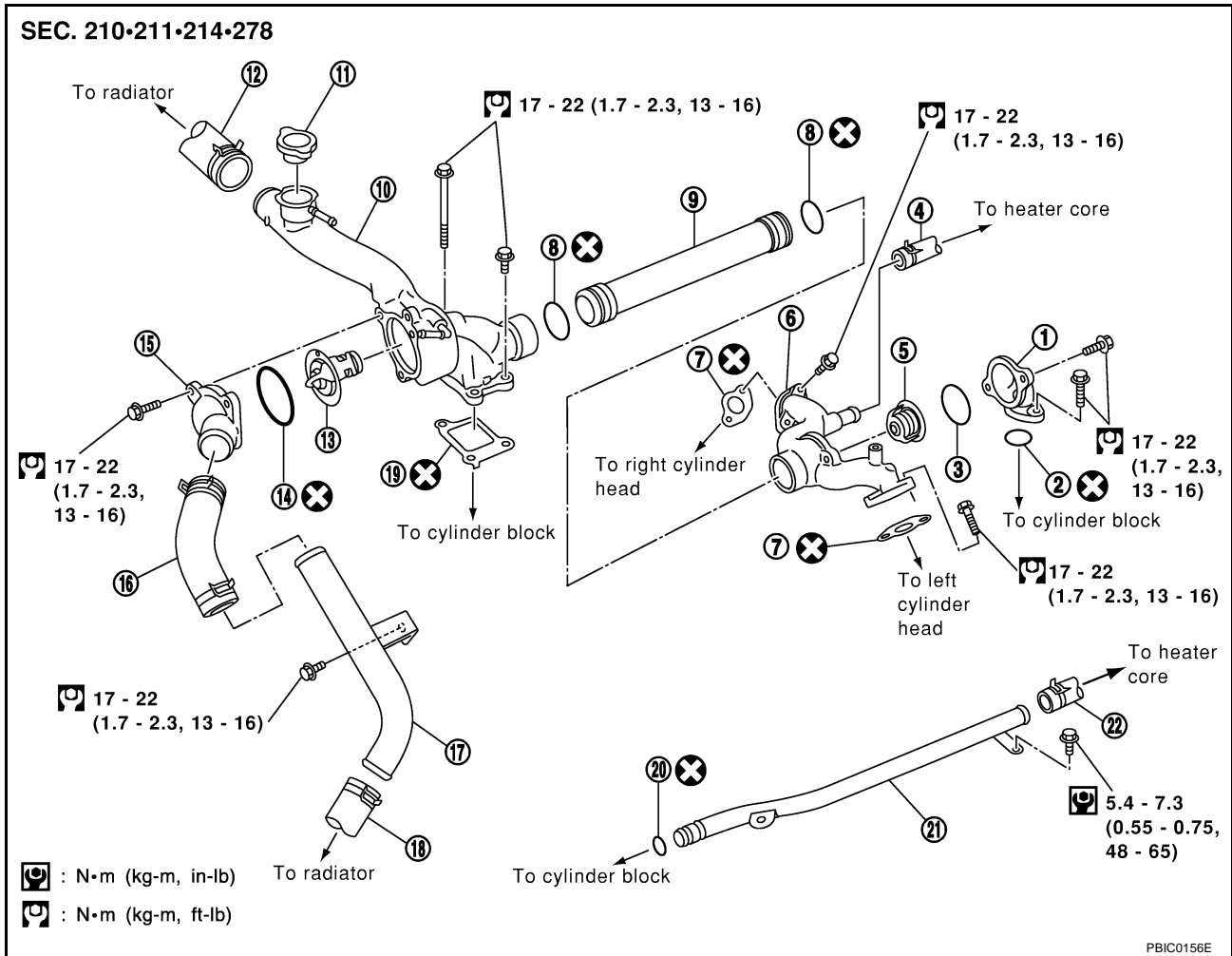

- | | | |
|------------------------|------------------------|-------------------------|
| 1. Water connector | 2. O-ring | 3. Rubber ring |
| 4. Heater hose | 5. Water control valve | 6. Rear water outlet |
| 7. Gasket | 8. O-ring | 9. Water outlet pipe |
| 10. Thermostat housing | 11. Radiator cap | 12. Radiator upper hose |
| 13. Thermostat | 14. Rubber ring | 15. Water inlet |
| 16. Water suction hose | 17. Water suction pipe | 18. Radiator lower hose |
| 19. Gasket | 20. O-ring | 21. Heater pipe |
| 22. Heater hose | | |

WARNING:

Never remove the radiator cap when the engine is hot. Serious burns could occur from high pressure fluid escaping from the radiator.

REMOVAL

1. Drain engine coolant.

CAUTION:

Perform when the engine is cold.

2. Remove air duct and engine room cover. For removing engine room cover, refer to [EM-11, "Removal and Installation"](#).
3. Remove water suction hose from water inlet side.
4. Remove water inlet and thermostat.
5. Remove intake manifold upper, intake manifold lower and water control valve.

THERMOSTAT AND WATER CONTROL VALVE

- Remove fuel injector harness, thermostat housing, water outlet pipe, rear water outlet and heater pipe (between left and right banks).

INSPECTION AFTER REMOVAL

- Place a thread so that it is caught in the valves of the thermostat and water control valve. Immerse fully in a container filled with water. Heat while stirring. (The example in the figure shows the thermostat.)
- The valve opening temperature is the temperature at which the valve opens and falls from the thread.
- Continue heating. Check the full-open lift amount.

NOTE:

The full-open lift amount standard temperature for the water control valve is the reference value.

- After checking the full-open lift amount, lower the water temperature and check the valve closing temperature.

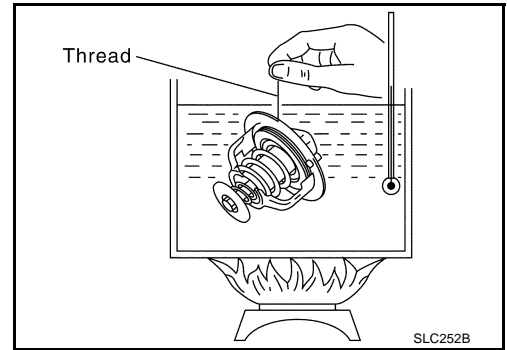

Standard values

	Thermostat	Water control valve
Valve opening temperature	80 - 84°C (176 - 183° F)	93.5 - 96.5°C (200 - 206° F)
Full-open lift amount	More than 10 mm/ 95°C (0.39 in/ 203 °F)	More than 8 mm/ 108°C (0.315 in/ 226 ° F)
Valve closing temperature	77°C (171°F) or higher	90°C (194° F) or higher

INSTALLATION

- Install in the reverse order of removal.

Installation of thermostat and water control valve

- Install the thermostat and water control valve with the whole circumference of each flange part fit securely inside the rubber ring. (The example in the figure shown the thermostat.)

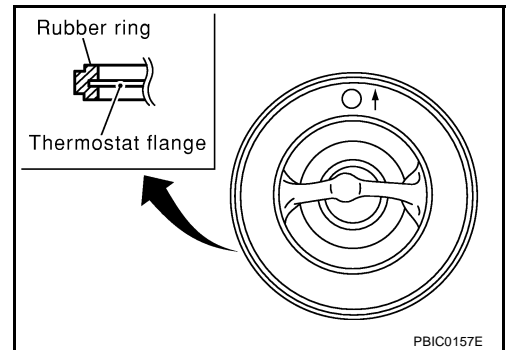

- Install the thermostat with the jiggle-valve facing upwards. (The position deviation may be within the range of $\pm 10^\circ$)
- Install the water control valve with the up-mark facing up and the frame center part facing upwards. (The position deviation may be within the range of $\pm 10^\circ$)

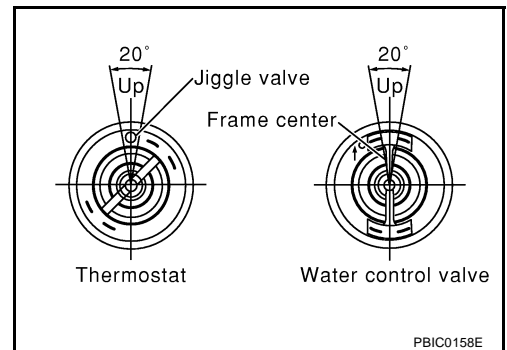

Installation of water outlet pipe and heater pipe

- First apply a neutral detergent to the O-rings, then quickly insert the insertion parts of the water outlet pipe and heater pipe into the installation holes.

SERVICE DATA AND SPECIFICATIONS (SDS)

SERVICE DATA AND SPECIFICATIONS (SDS)

PPF:00030

Standard and Limit CAPACITY

EBS00308

Coolant capacity [With reservoir tank (MAX level)]	Approximately 9.8 ℓ (10-3/8 US qt, 8-5/8 Imp qt)
Cooling fan fluid capacity	777 m ℓ (26.3 US floz, 27.4 Imp floz)

THERMOSTAT

Valve opening temperature	80 - 84°C (176 - 183°F)
Valve lift	More than 10 mm/95°C (0.39 in/203°F)

WATER CONTROL VALVE

Valve opening temperature	93.5 - 96.5°C (200 - 206°F)
Valve lift	More than 8 mm/108°C (0.315 in/226°F)

RADIATOR

Unit: kPa (kg/cm², psi)

Cap relief pressure	Standard	78 - 98 (0.8 - 1.0, 11 - 14)
	Limit	59 (0.6, 9)
Leakage test pressure		157 (1.6, 23)

Tightening Torque

EBS002NI

Unit: N·m (kg-m, ft-lb)
Unit: N·m (kg-m, in-lb)*

Cylinder block drain plug	14.7 - 24.5 (1.5 - 2.5, 11 - 18)
Radiator mounting bracket	3.8 - 4.5 (0.39 - 0.46, 34 - 39)*
Radiator drain plug	0.78 - 1.6 (0.08 - 0.16, 7 - 13)*
Radiator coolant temperature sensor	4.9 - 9.8 (0.5 - 1.0, 44 - 86)*
Cooling fan shroud	3.8 - 4.5 (0.39 - 0.46, 34 - 39)*
Fan	7.8 - 11.8 (0.80 - 1.2, 70 - 104)*
Fan motor	3.9 - 4.9 (0.40 - 0.50, 35 - 43)*
Cooling fan fluid cooler	3.0 - 3.9 (0.31 - 0.40, 27 - 34)*
Water pump pulley	7.2 - 9.2 (0.73 - 0.94, 64 - 81)*
Water pump	24.5 - 31.4 (2.5 - 3.2, 18 - 23)
Water inlet	16.7 - 22.6 (1.7 - 2.3, 13 - 16)
Thermostat housing	16.7 - 22.6 (1.7 - 2.3, 13 - 16)
Rear water outlet	16.7 - 22.6 (1.7 - 2.3, 13 - 16)
Water connector (Water control valve cover)	16.7 - 22.6 (1.7 - 2.3, 13 - 16)
Water suction pipe	16.7 - 22.6 (1.7 - 2.3, 13 - 16)

SERVICE DATA AND SPECIFICATIONS (SDS)
