

SECTION **LAN**
LAN SYSTEM

CONTENTS

LAN	TEM) 19
PRECAUTIONS	3
Precautions for Supplemental Restraint System (SRS) "AIR BAG" and "SEAT BELT PRE-TENSIONER"	3
IVMS (LAN)	4
Overall Description	4
OUTLINE	4
BCM (BODY CONTROL MODULE)	4
LCU (LOCAL CONTROL UNIT)	4
CONTROLLED SYSTEMS	4
Component Parts and Harness Connector Location	5
Sleep/Wake-up Control	5
SLEEP CONTROL	5
WAKE-UP CONTROL	6
Fail-safe System	6
CONSULT-II Function	6
DIAGNOSTIC ITEMS DESCRIPTION	6
DIAGNOSTIC ITEMS APPLICATION	7
On Board Diagnosis	7
DIAGNOSIS ITEM	7
Schematic	8
POWER SUPPLY, GROUND AND COMMUNICATION CIRCUITS	8
Wiring Diagram — COMM —	9
POWER SUPPLY, GROUND AND COMMUNICATION CIRCUITS	9
WITH DOOR MIRROR SYSTEM	13
Schematic — BCM —	14
Schematic — LCU01 —	16
DRIVER'S DOOR CONTROL UNIT	16
Schematic — LCU02 —	17
DRIVER'S SEAT CONTROL UNIT	17
Schematic — LCU03 —	18
DRIVER'S SIDE DOOR MIRROR CONTROL UNIT (WITH DOOR MIRROR MEMORY SYSTEM)	18
Schematic — LCU04 —	19
PASSENGER SIDE DOOR MIRROR CONTROL UNIT (WITH DOOR MIRROR MEMORY SYSTEM)	19
	CAN
	PRECAUTIONS
	20
	Precautions for Supplemental Restraint System (SRS) "AIR BAG" and "SEAT BELT PRE-TENSIONER"
	20
	Precautions For Trouble Diagnosis
	20
	CAN SYSTEM
	20
	Precautions For Harness Repair
	20
	CAN SYSTEM
	20
	CAN COMMUNICATION
	21
	System Description
	21
	FOR VDC MODELS
	21
	FOR ICC MODELS
	22
	CAN SYSTEM (FOR VDC MODELS)
	24
	System Description
	24
	Component Parts and Harness Connector Location
	24
	Wiring Diagram — CAN —
	25
	Work Flow
	27
	CHECK SHEET
	28
	CHECK SHEET RESULTS (EXAMPLE)
	29
	Circuit Check Between VDC/TCS/ABS Control Unit and Steering Wheel Angle Sensor
	32
	Circuit Check Between Steering Wheel Angle Sensor and Combination Meter
	34
	ECM Circuit Check
	34
	VDC/TCS/ABS Control Unit Circuit Check
	35
	Steering Wheel Angle Sensor Circuit Check
	35
	Combination Meter Circuit Check
	36
	TCM Circuit Check
	36
	CAN Communication Circuit Check
	37
	Component Inspection
	41
	ECM/TCM INTERNAL CIRCUIT INSPECTION
	41
	CAN SYSTEM (FOR ICC MODELS)
	42
	System Description
	42
	Component Parts and Harness Connector Location
	42
	Schematic
	43
	Wiring Diagram — CAN —
	44

Work Flow	47	ECM Circuit Check	62
CHECK SHEET	48	VDC/TCS/ABS Control Unit Circuit Check	63
CHECK SHEET RESULTS (EXAMPLE)	49	ICC Sensor Circuit Check	63
Circuit Check VDC/TCS/ABS Control Unit and ICC Sensor	59	ICC Unit Circuit Check	64
Circuit Check Between ICC sensor and ICC unit ...	60	Steering Wheel Angle Sensor Circuit Check	64
Circuit Check Between ICC unit and Steering Wheel Angle Sensor	61	Combination Meter Circuit Check	65
Circuit Check Between Steering Wheel Angle Sen- sor and Combination Meter	62	TCM Circuit Check	65
		CAN Communication Circuit Check	66
		Component Inspection	70
		ECM/TCM INTERNAL CIRCUIT INSPECTION...	70

PRECAUTIONS

PFP:00001

Precautions for Supplemental Restraint System (SRS) “AIR BAG” and “SEAT BELT PRE-TENSIONER”

EKS001PA

The Supplemental Restraint System such as “AIR BAG” and “SEAT BELT PRE-TENSIONER”, used along with a front seat belt, helps to reduce the risk or severity of injury to the driver and front passenger for certain types of collision. Information necessary to service the system safely is included in the SRS and SB section of this Service Manual.

WARNING:

- To avoid rendering the SRS inoperative, which could increase the risk of personal injury or death in the event of a collision which would result in air bag inflation, all maintenance must be performed by an authorized NISSAN/INFINITI dealer.
- Improper maintenance, including incorrect removal and installation of the SRS, can lead to personal injury caused by unintentional activation of the system. For removal of Spiral Cable and Air Bag Module, see the SRS section.
- Do not use electrical test equipment on any circuit related to the SRS unless instructed to in this Service Manual. SRS wiring harnesses can be identified by yellow and/or orange harnesses or harness connectors.

A
B
C
D
E
F
G
H
I
J

LAN

L
M

IVMS (LAN)

Overall Description OUTLINE

The In-Vehicle Multiplexing System, IVMS (LAN system), consists of a BCM (Body Control Module) and five LCUs (Local Control Units). Some switches and electrical loads are connected to each LCU. Some electrical systems are directly connected to the BCM. Control of each LCU, (which is provided by a switch and electrical load), is accomplished by the BCM, via multiplex data lines (A-1, A-2 or A-3) connected between them.

BCM (BODY CONTROL MODULE)

The BCM, which is a master unit of the IVMS (LAN), consists of microprocessor, memory and communication LSI sections and has communication and control functions. It receives data signals from the LCUs and sends electrical load data signals to them.

LCU (LOCAL CONTROL UNIT)

The LCUs, which are slave units of the BCM, have only a communication function and consist of communication LSI and input-output interface circuits. They receive data signals from the BCM, control the ON/OFF operations of electrical loads and the sleep operation, as well as send switch signals to the BCM.

CONTROLLED SYSTEMS

The IVMS controls several body-electrical systems. The systems included in the IVMS are as follows:

- Power window system (Refer to [GW-15, "POWER WINDOW SYSTEM"](#))
- Power door lock system (Refer to [BL-17, "POWER DOOR LOCK SYSTEM"](#))
- Remote keyless entry system (Refer to [BL-45, "REMOTE KEYLESS ENTRY SYSTEM"](#))
- Vehicle Security (Theft warning) system (Refer to [BL-100, "VEHICLE SECURITY \(THEFT WARNING\) SYSTEM"](#))
- Reverse interlock door mirror system (Refer to [GW-68, "REVERSE INTERLOCK DOOR MIRROR SYSTEM"](#))
- Interior room lamp (Refer to [LT-80, "INTERIOR ROOM LAMP"](#))
- Step lamp (Refer to [LT-107, "STEP LAMP"](#))
- Illumination (Refer to [LT-125, "ILLUMINATION"](#))
- Auto drive positioner (Refer to [SE-12, "AUTOMATIC DRIVE POSITIONER"](#))
- Auto light (Refer to [LT-5, "HEADLAMP \(FOR USA\)"](#))
- Door warning lamp (Refer to [DI-27, "WARNING LAMPS"](#))
- Ignition key warning (Refer to [DI-50, "WARNING CHIME"](#))
- Light warning (Refer to [DI-50, "WARNING CHIME"](#))
- Seat belt warning (Refer to [DI-50, "WARNING CHIME"](#))
- Front wiper and washer system (Refer to [WW-3, "FRONT WIPER AND WASHER SYSTEM"](#))
- Rear window defogger timer (Refer to [GW-53, "REAR WINDOW DEFOGGER"](#))
- Trouble-diagnosis system
 - with CONSULT-II
 - ON BOARD

Also, IVMS has the "sleep/wake-up control" function. IVMS puts itself (the whole IVMS system) to sleep under certain conditions to prevent unnecessary power consumption. Then, when a certain input is detected, the system wakes itself up. For more detailed information, refer to "Sleep/Wake-up Control".

Component Parts and Harness Connector Location

EKS001PE

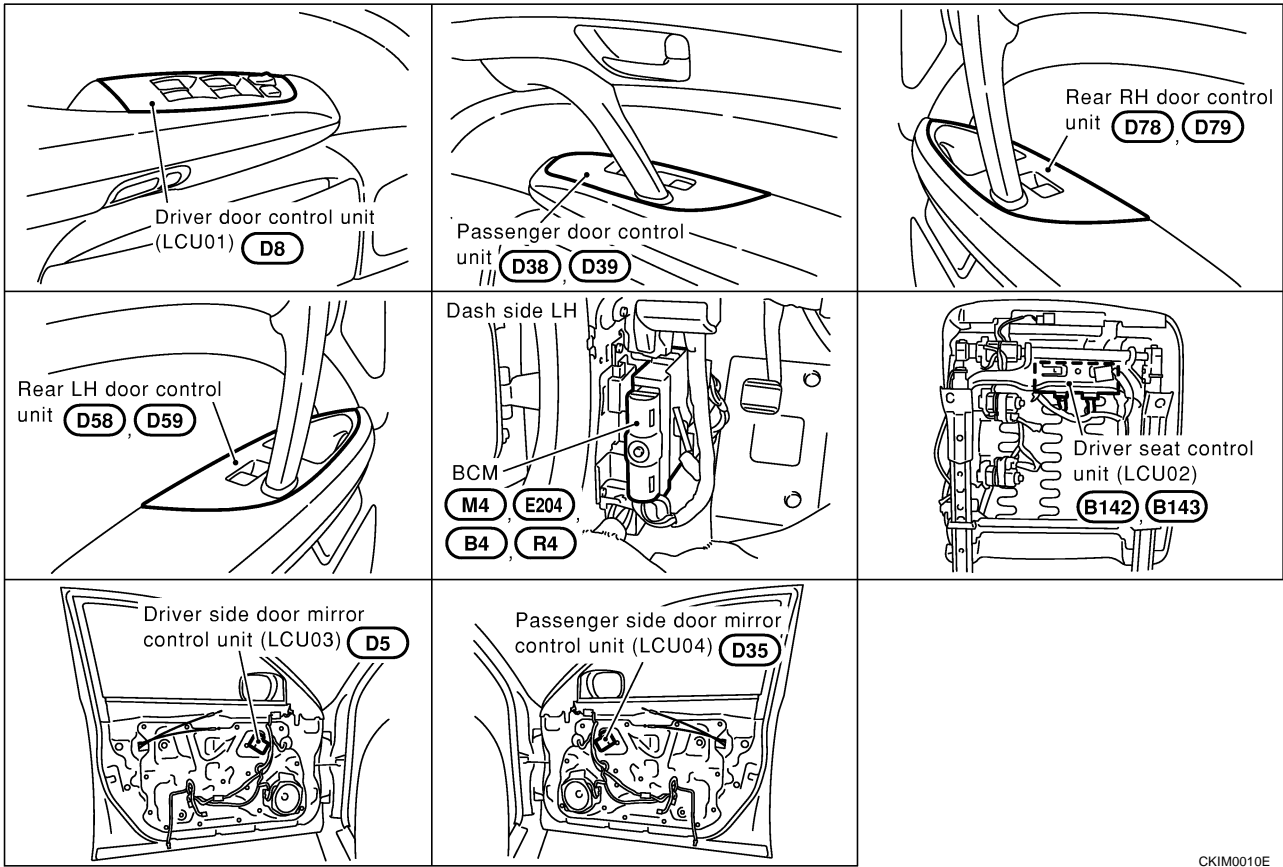

CKIM0010E

Sleep/Wake-up Control
SLEEP CONTROL

EKS001PF

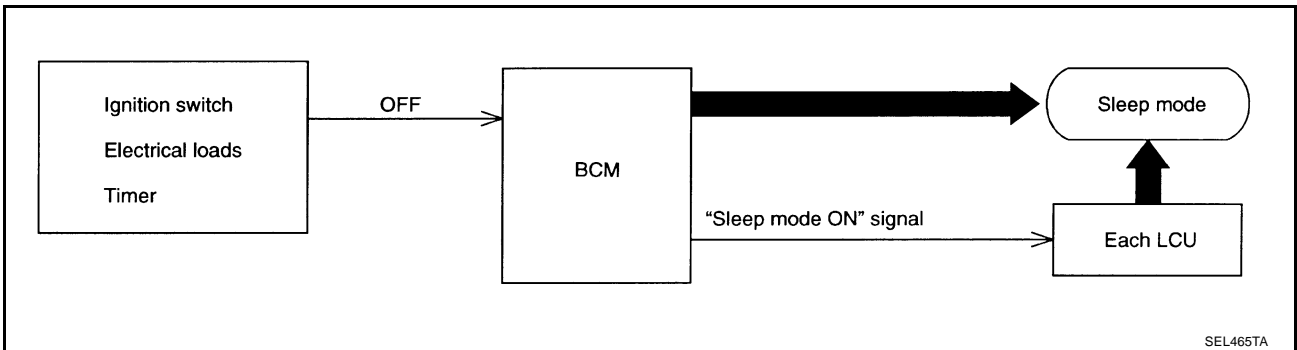

“Sleep” control prevents unnecessary power consumption. After the following conditions are met, the BCM suspends the communication between itself and all LCU’s. The whole IVMS is set in the “sleep” mode.

- Ignition switch “OFF”
- All electrical loads (in the IVMS) “OFF”
- Timer “OFF”

WAKE-UP CONTROL

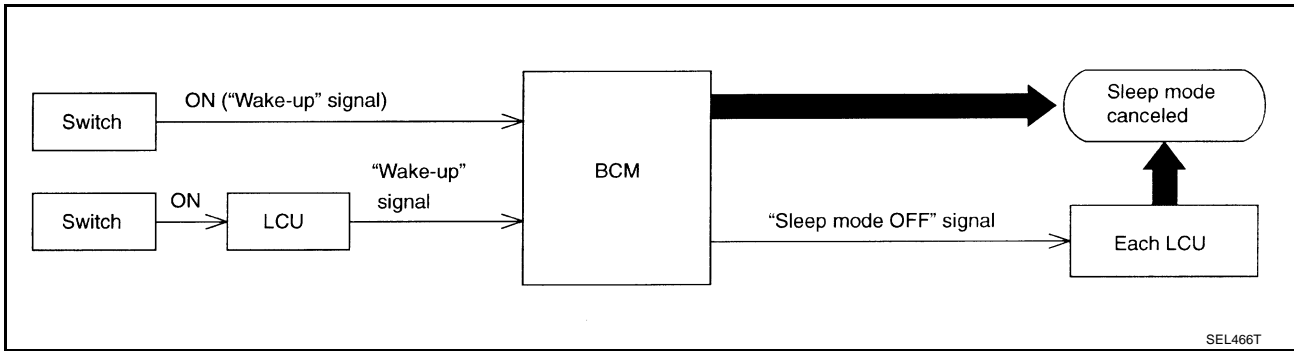

As shown above, when the BCM detects a “wake-up” signal, it wakes up the whole system and starts communicating again. The “sleep” mode of all LCUs is now canceled, and the BCM returns to the normal control mode. When any one of the following switches are turned ON, the “sleep” mode is canceled:

- All switches combined or connected with BCM
- All switches combined or connected with LCU

Fail-safe System

EKS001PG

Fail-safe system operates when the signal from LCU is judged to be malfunctioning by BCM. If LCU sends no signal or an abnormal signal to BCM a certain number of times in succession, the IVMS is set in a fail-safe condition. In the fail-safe condition, the electrical loads controlled by the switch on the questionable LCU will be operated at fail-safe mode.

CONSULT-II Function

EKS001R9

CONSULT-II executes the following functions by combining data reception and command transmission via the communication line from BCM. IVMS communication inspection, work support (only function setting of seats and steering wheel), self-diagnosis, data monitor, and active test display.

DIAGNOSTIC ITEMS DESCRIPTION

IVMS diagnosis position	Diagnosis mode	Description
IVMS– COMM CHECK	IVMS– COMM DIAGNOSIS	Diagnosis of continuity in the communication line(s), and of the function of the IVMS-communication interface between the body control module and the local control units, accomplished by transmitting a signal from the body control module to the local control units.
	WAKE–UP DIAGNOSIS	Diagnosis of the “wake-up” function of local control units by having a technician input the switch data into the local control unit that is in the temporary “sleep” condition.
Each system inspection .	Work support	Changes the setting for each function.
	Self-diagnosis results	Carries out self-diagnosis.
	Data monitor	Displays data relative to the body control module (BCM) input signals and various control related data for each system.
	Active test	Turns on/off actuators, relay and according to the commands transmitted by the CONSULT-II unit.
BCM PART NUMBER		Displays BCM part No.

DIAGNOSTIC ITEMS APPLICATION

Test item	Diagnosed system	MODE					
		IVMS COMM DIAGNOSIS	WAKE-UP DIAGNOSIS	SELF DIAGNOSTIC RESULTS	DATA MONITOR	ACTIVE TEST	WORK SUPPORT
IVMS-COMM CHECK	IVMS communication and wake-up function	×	×				
DOOR LOCK	Power door lock system			×	×	×	×
AUTO DRIVE POSITIONER	Automatic drive positioner / Reverse interlock door mirror system			×	×	×	
WIPER	Front wiper and washer system				×	×	×
REAR DEFOGGER	Rear window defogger				×	×	
IGN KEY WARN ALM	Warning chime				×	×	
LIGHT WARN ALM	Warning chime				×	×	
SEAT BELT TIMER	Warning chime				×	×	
THEFT WARNING SYSTEM	Vehicle Security (Theft warning) system				×	×	
STEP LAMP	Step lamps				×	×	
MULTI-REMOTE CONT-SYS	Remote keyless entry system				×	×	×
INTERIOR ILLUMINATION	Interior room lamp				×	×	×
SUNROOF RELAY	Sunroof				×	×	
DOOR OPEN WARNING	Warning chime				×	×	
AUTO LIGHT SYSTEM	Headlamp				×	×	×

A
B
C
D
E
F
G
H
I
J
LAN
L
M

X: Applicable

For diagnostic item in each control system, read the CONSULT-II Operation Manual.

On Board Diagnosis

EKS001RA

ON BOARD DIAGNOSTIC RESULTS INDICATOR LAMP

- Front map lamps and step lamps (all seats) act as the indicators for the on board diagnosis.

DIAGNOSIS ITEM

Diagnosis item	Content
IVMS communication diagnosis	Diagnosis any abnormality or inability of communication between BCM and LCUs.
Switch monitor	Monitoring conditions of switches connected to BCM, LCUs and Door control units.
Power door lock system self-diagnosis	Diagnose malfunctions in the each door lock actuator system.
Auto drive positioner self-diagnosis	Diagnose malfunctions in the each motor and sensor in the electrical load parts of the driver power seat system (sliding, reclining, and lifter [front/rear]), of the steering wheel system (tilt, telescoping), and of door mirror.

Schematic

POWER SUPPLY, GROUND AND COMMUNICATION CIRCUITS

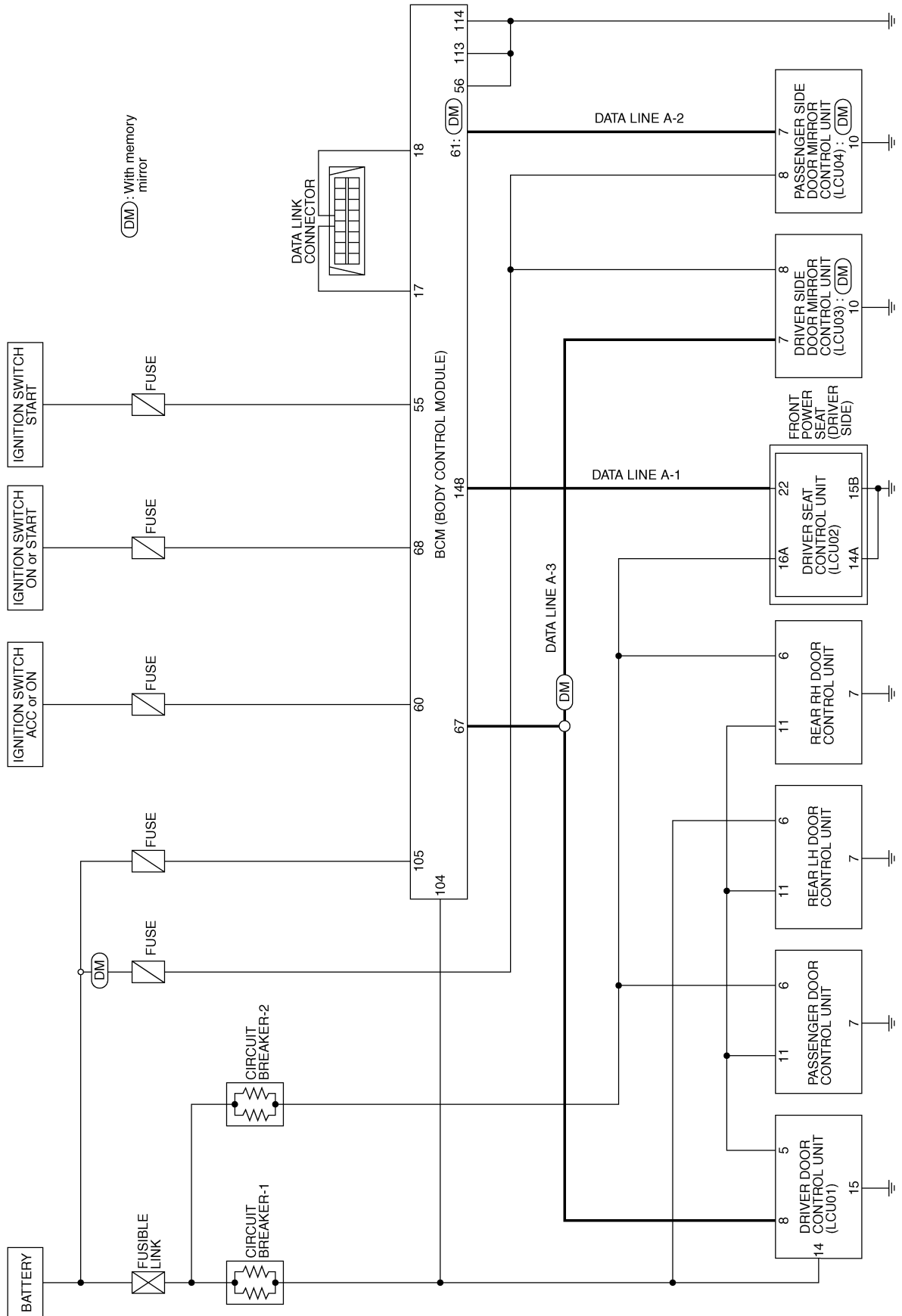

Wiring Diagram — COMM —
POWER SUPPLY, GROUND AND COMMUNICATION CIRCUITS

LAN-COMM-01

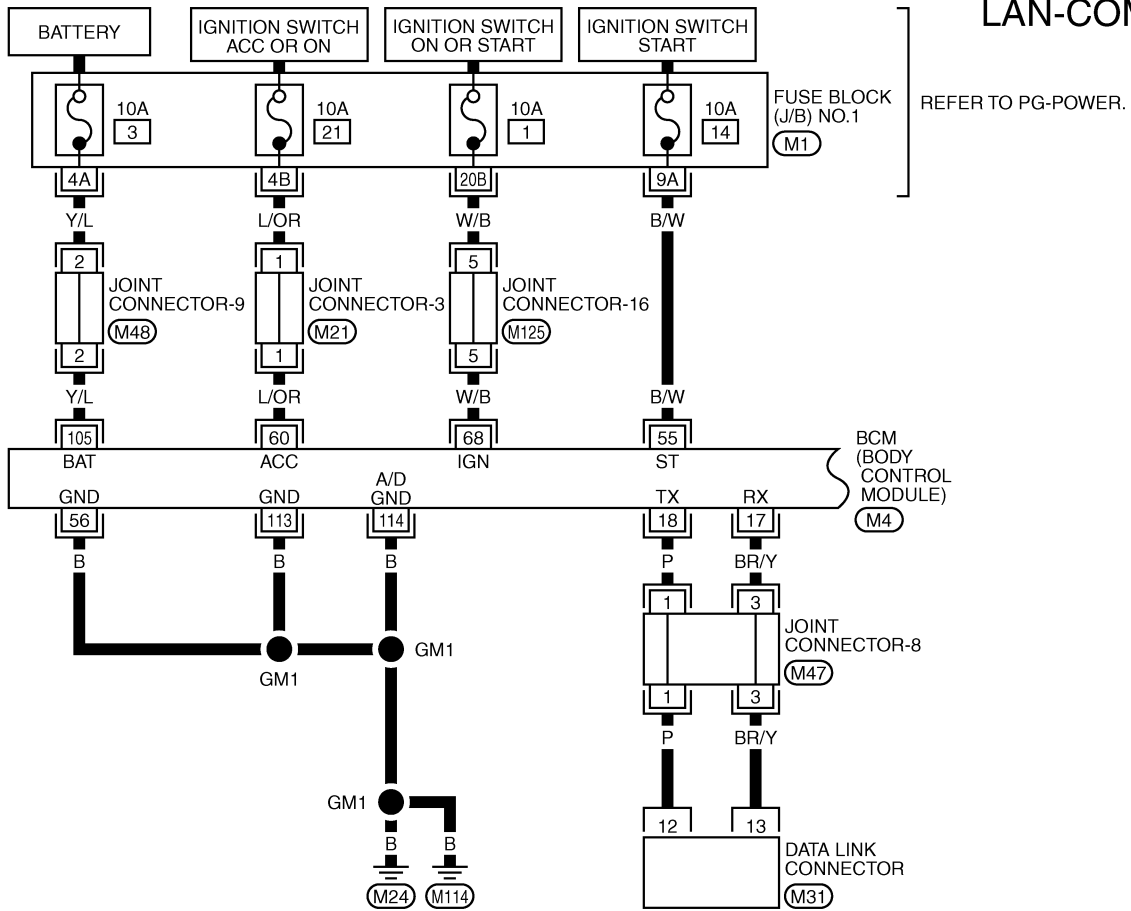

REFER TO PG-POWER.

BCM (BODY CONTROL MODULE) (M4)

REFER TO THE FOLLOWING.
 (M1) - FUSE BLOCK-JUNCTION BOX (J/B) NO.1
 (M4) - ELECTRICAL UNITS

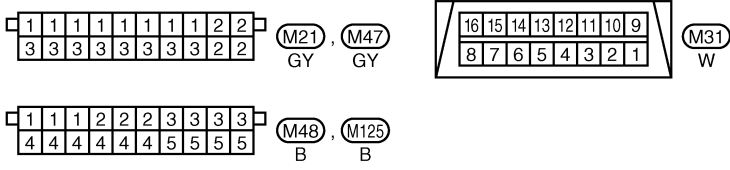

A
B
C
D
E
F
G
H
I
J
L
M

LAN

LAN-COMM-02

REFER TO PG-POWER.

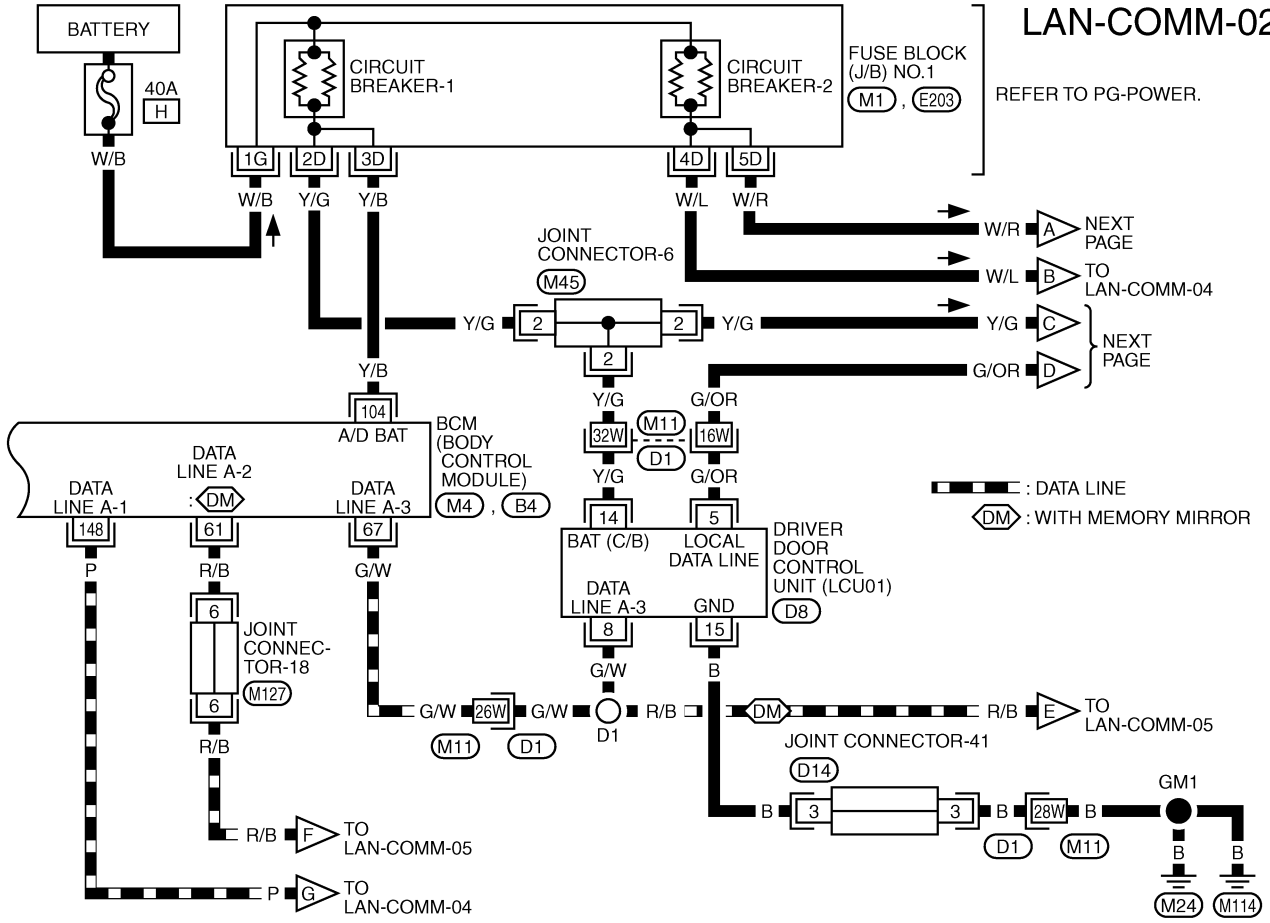

----- : DATA LINE
 ◁DM▷ : WITH MEMORY MIRROR

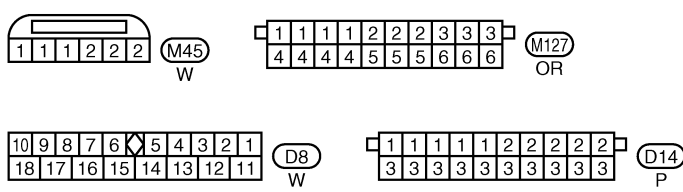

REFER TO THE FOLLOWING.
 (D1) -SUPER MULTIPLE JUNCTION (SMJ)
 (M1), (E203) -FUSE BLOCK-JUNCTION BOX (J/B) NO.1
 (M4), (B4) -ELECTRICAL UNITS

LAN-COMM-03

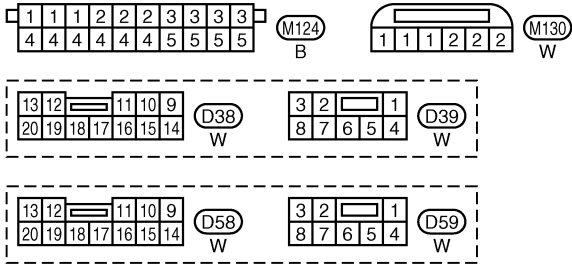
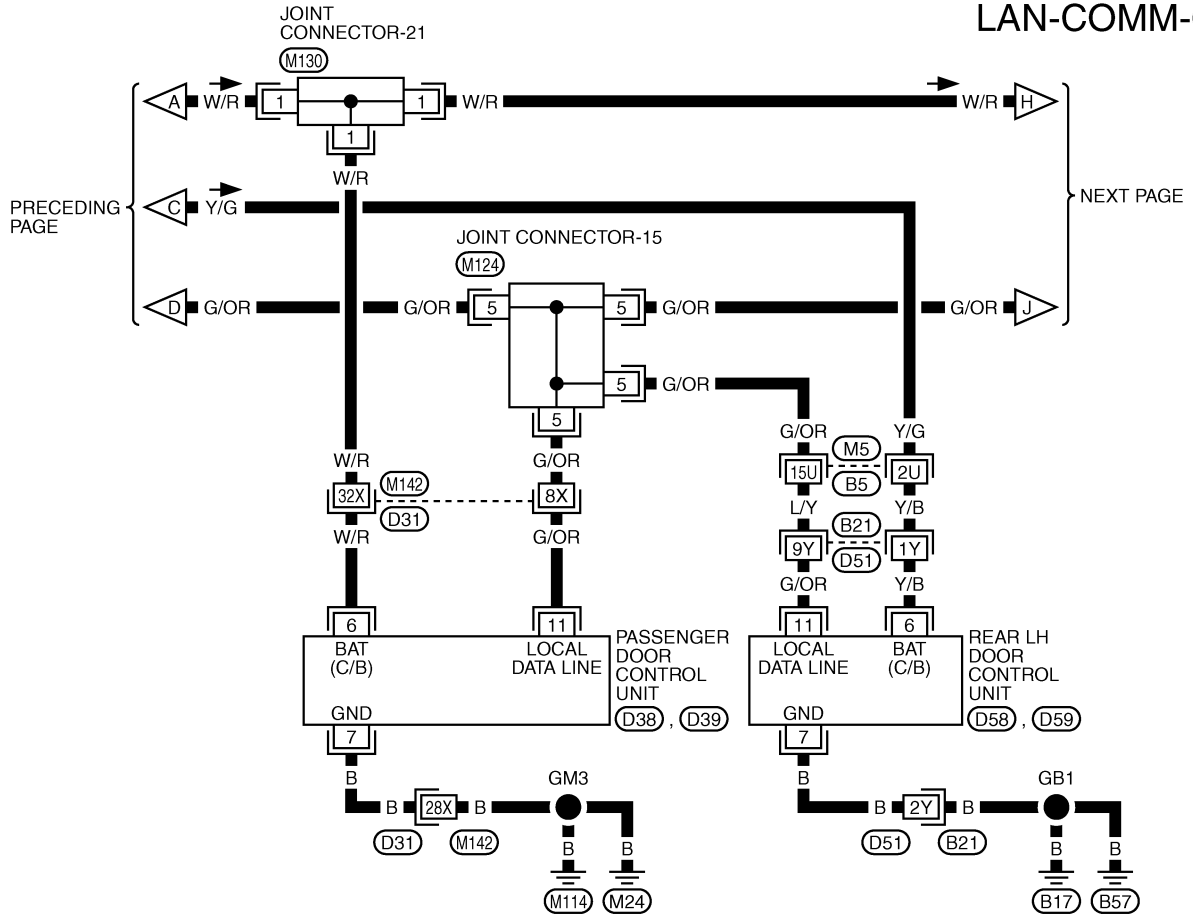

REFER TO THE FOLLOWING.
 (M5), (B21), (D31) -SUPER
 MULTIPLE JUNCTION (SMJ)

TKWM0124E

A
B
C
D
E
F
G
H
I
J
L
M

LAN

LAN-COMM-04

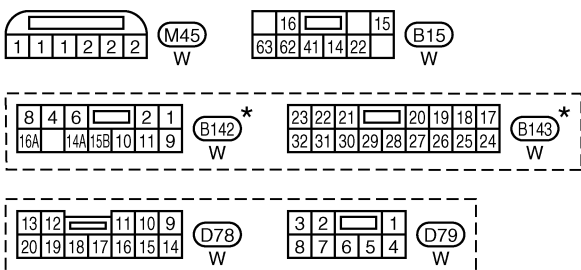
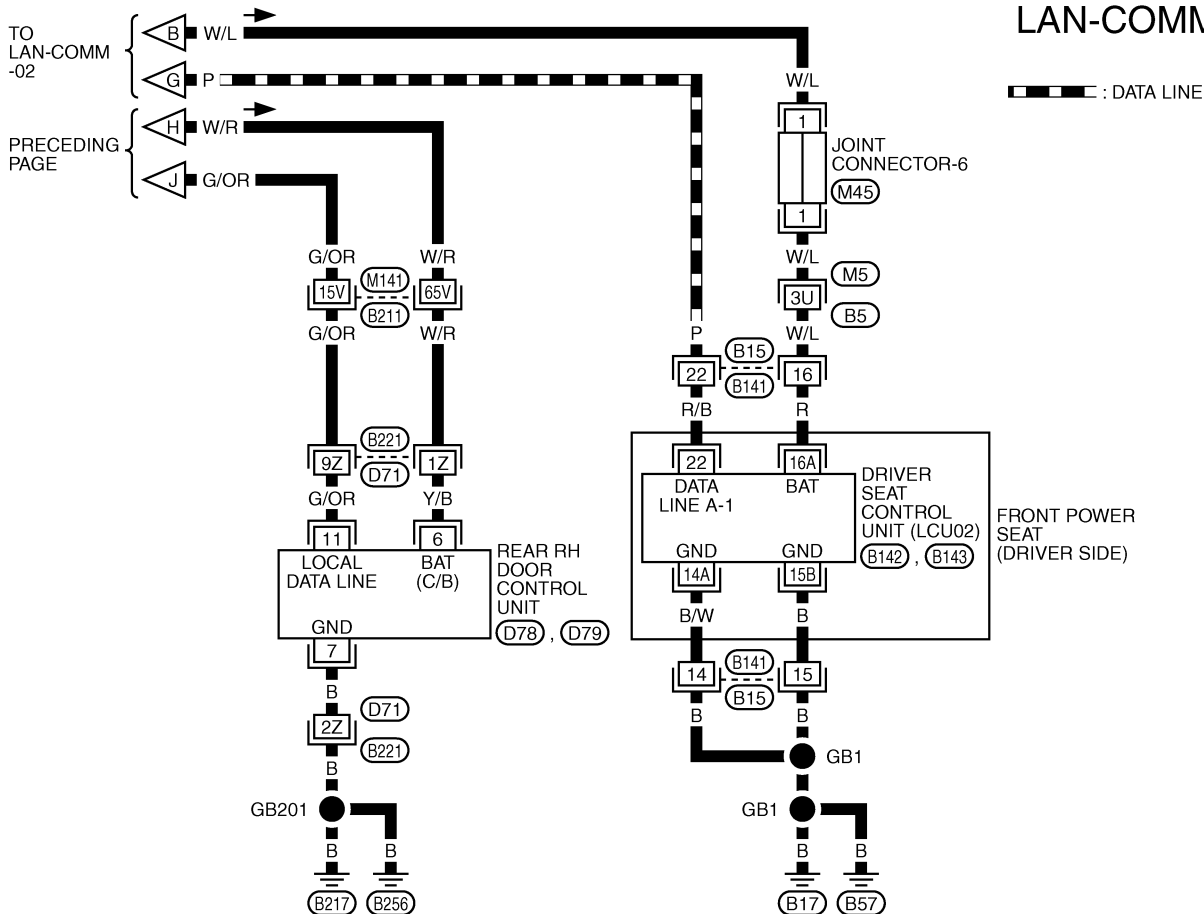

REFER TO THE FOLLOWING.
 (M5), (B211), (B221) -SUPER
 MULTIPLE JUNCTION (SMJ)

★: THIS CONNECTOR IS NOT SHOWN IN "HARNESS LAYOUT", PG SECTION.

TKWM0125E

WITH DOOR MIRROR SYSTEM

LAN-COMM-05

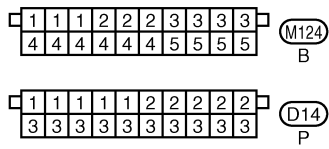
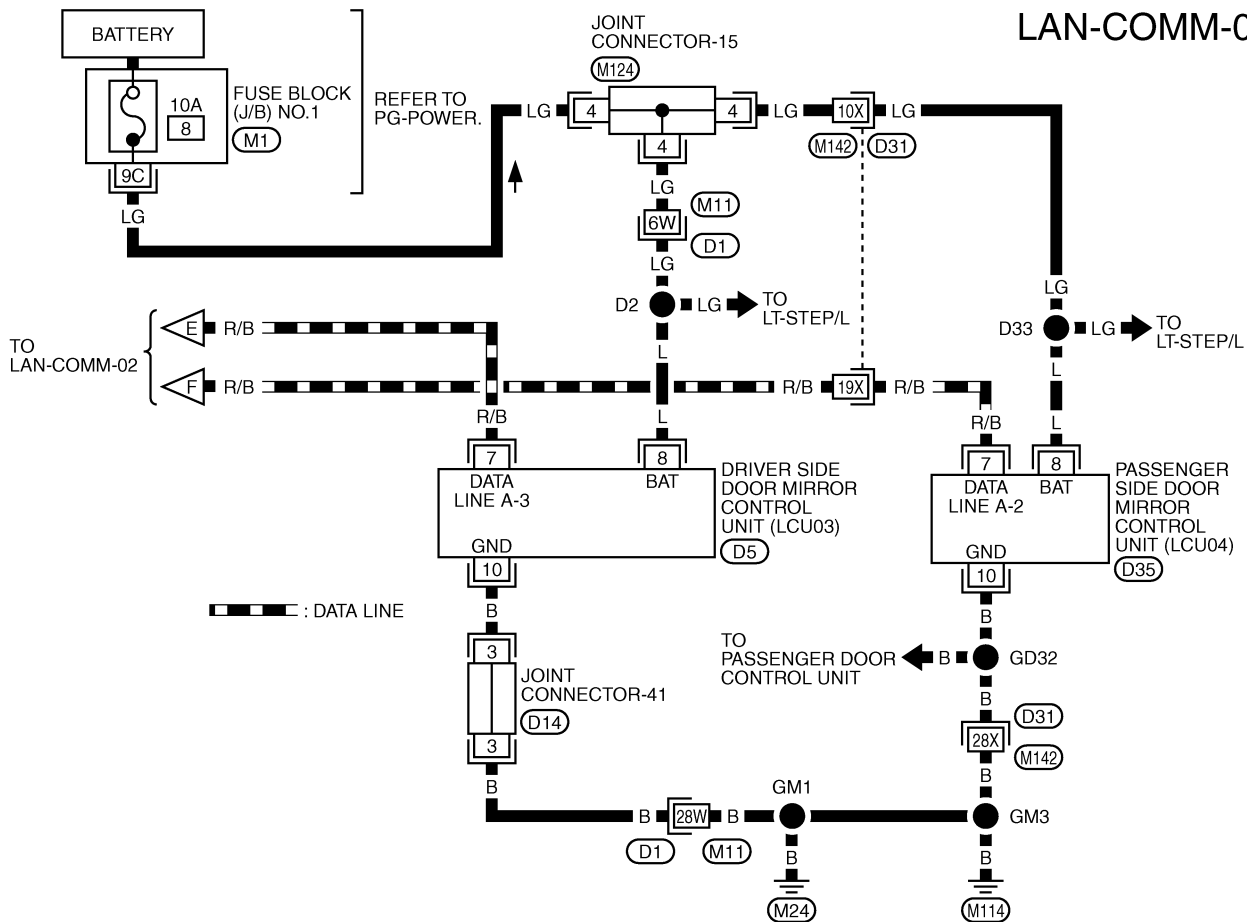

REFER TO THE FOLLOWING.
 (D1), (D31) -SUPER MULTIPLE JUNCTION (SMJ)
 (M1) -FUSE BLOCK-JUNCTION BOX (J/B) NO.1

A
B
C
D
E
F
G
H
I
J
LAN
L
M

TKWM0126E

Schematic — BCM —

EKS001PL

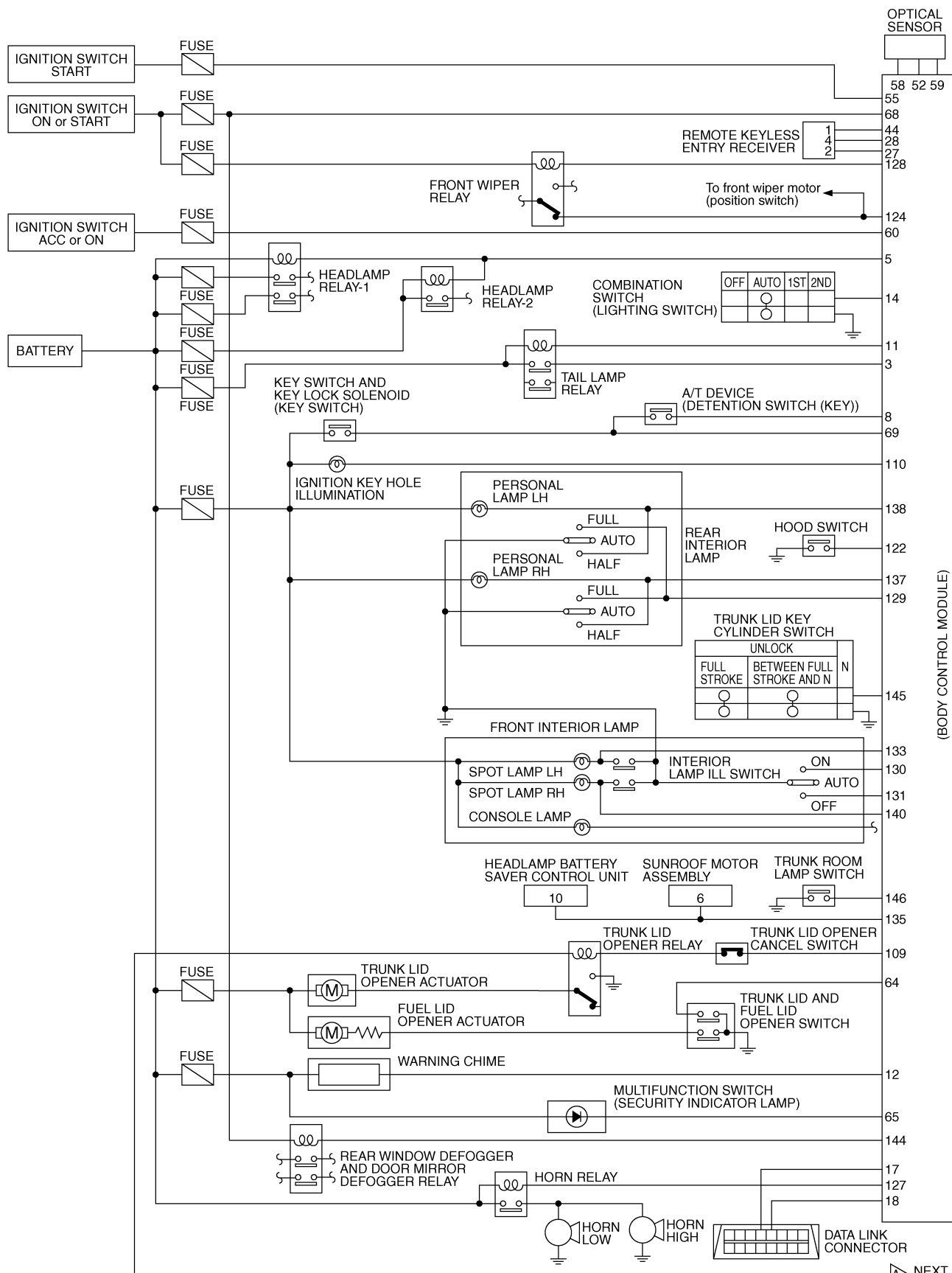

NEXT PAGE
TKWM0235E

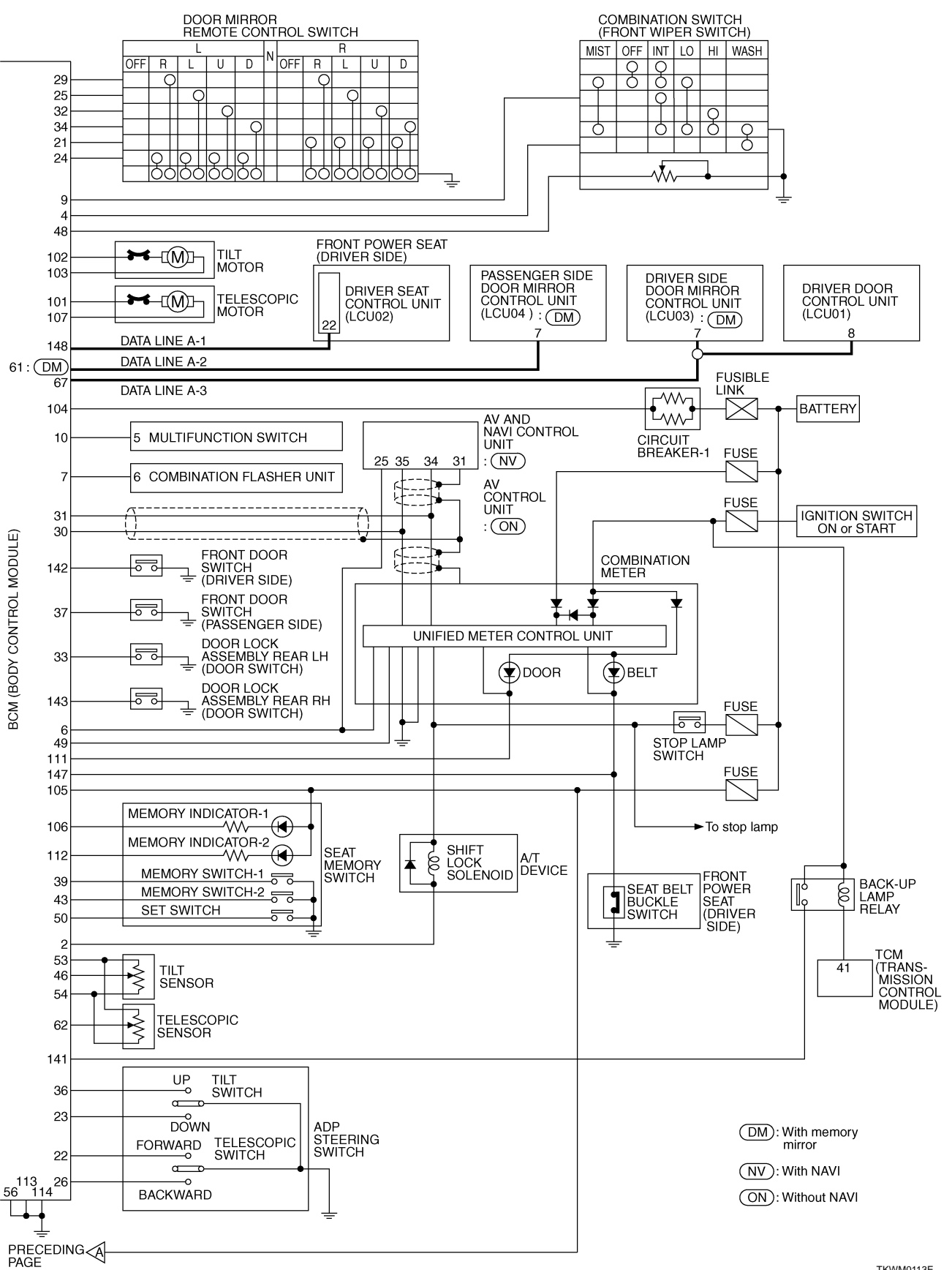

A
B
C
D
E
F
G
H
I
J
LAN
L
M

**Schematic — LCU01 —
DRIVER'S DOOR CONTROL UNIT**

EKS001PM

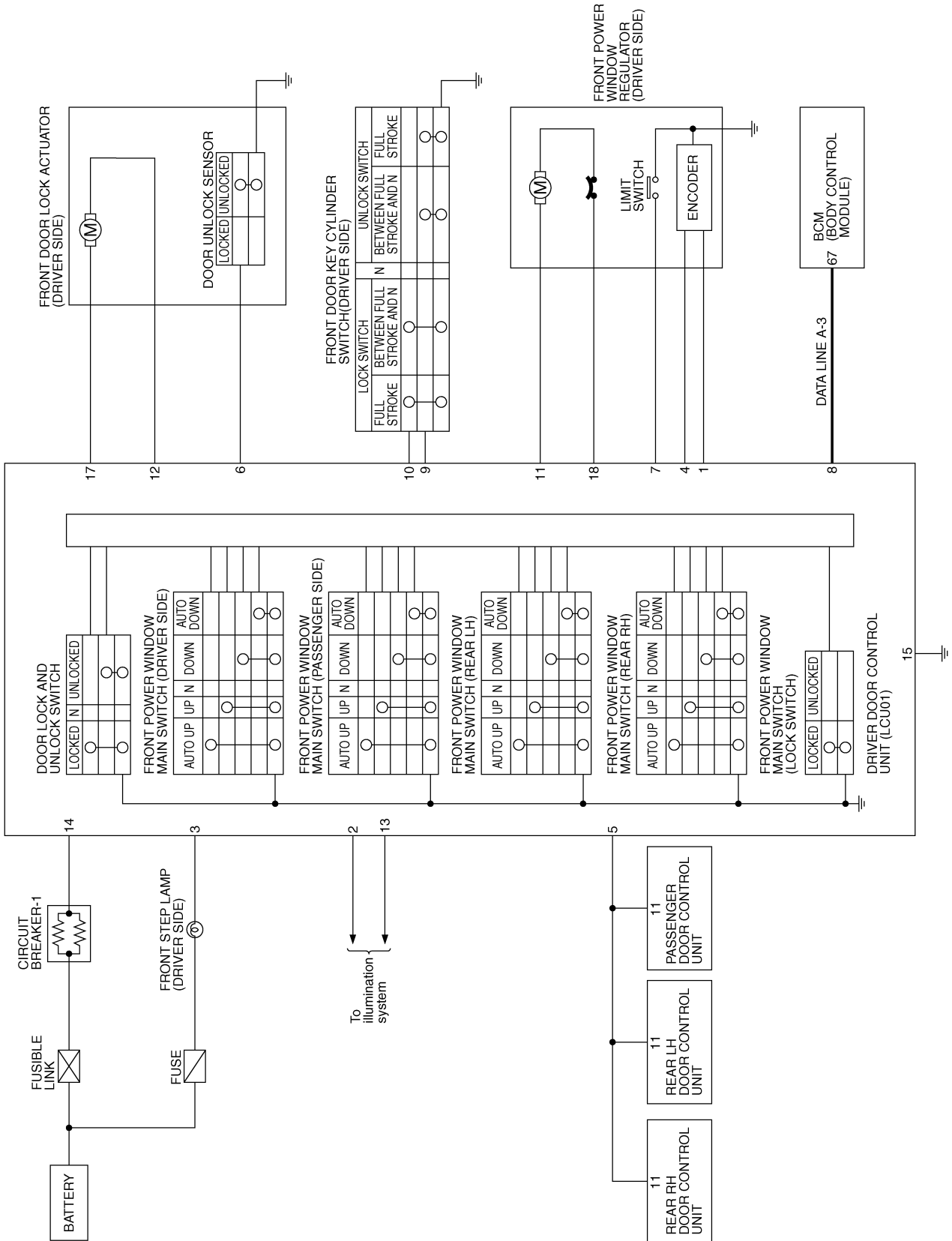

TKWM0114E

**Schematic — LCU02 —
DRIVER'S SEAT CONTROL UNIT**

A
B
C
D
E
F
G
H
I
J
LAN
L
M

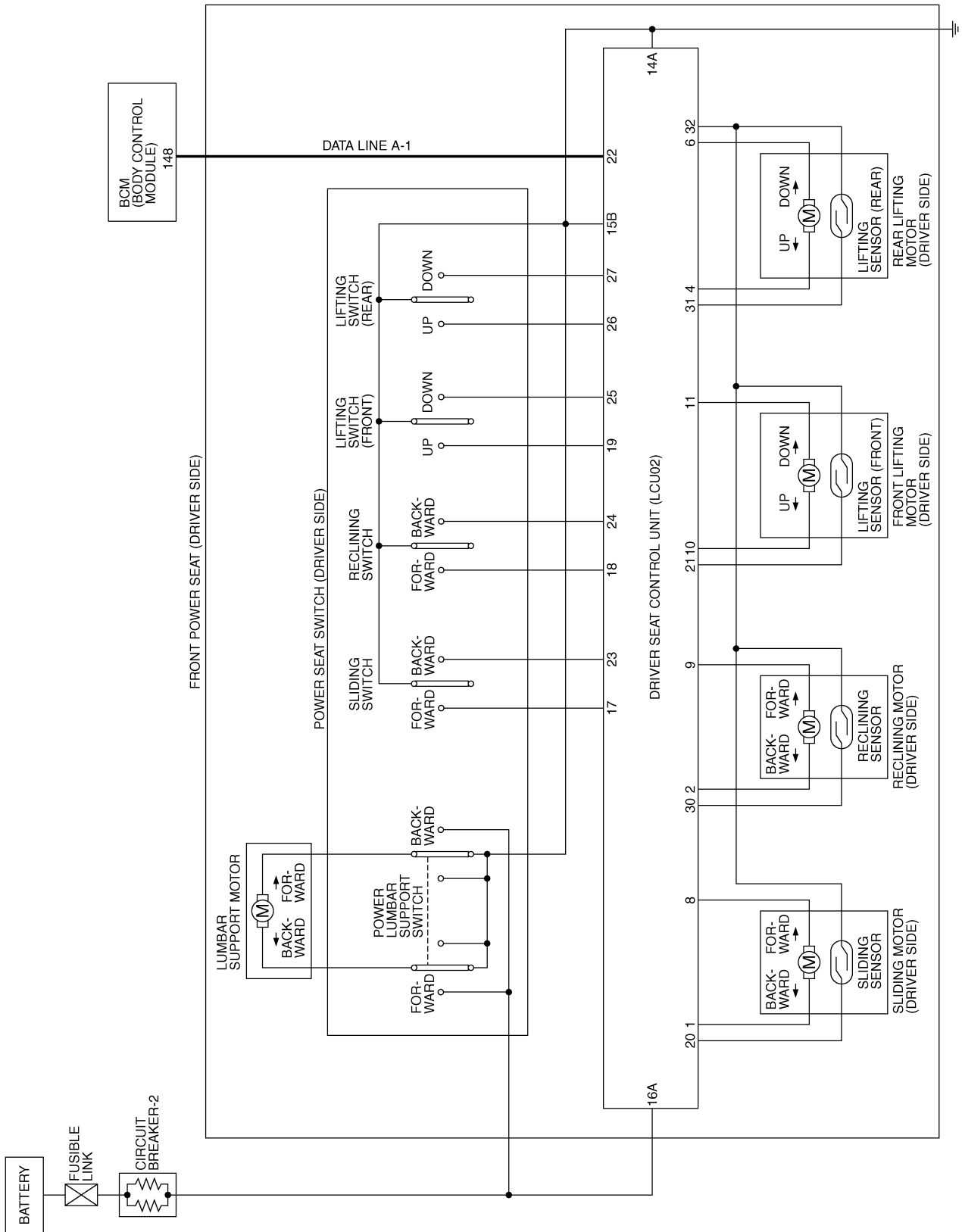

Schematic — LCU03 —

EKS001PO

DRIVER'S SIDE DOOR MIRROR CONTROL UNIT (WITH DOOR MIRROR MEMORY SYSTEM)

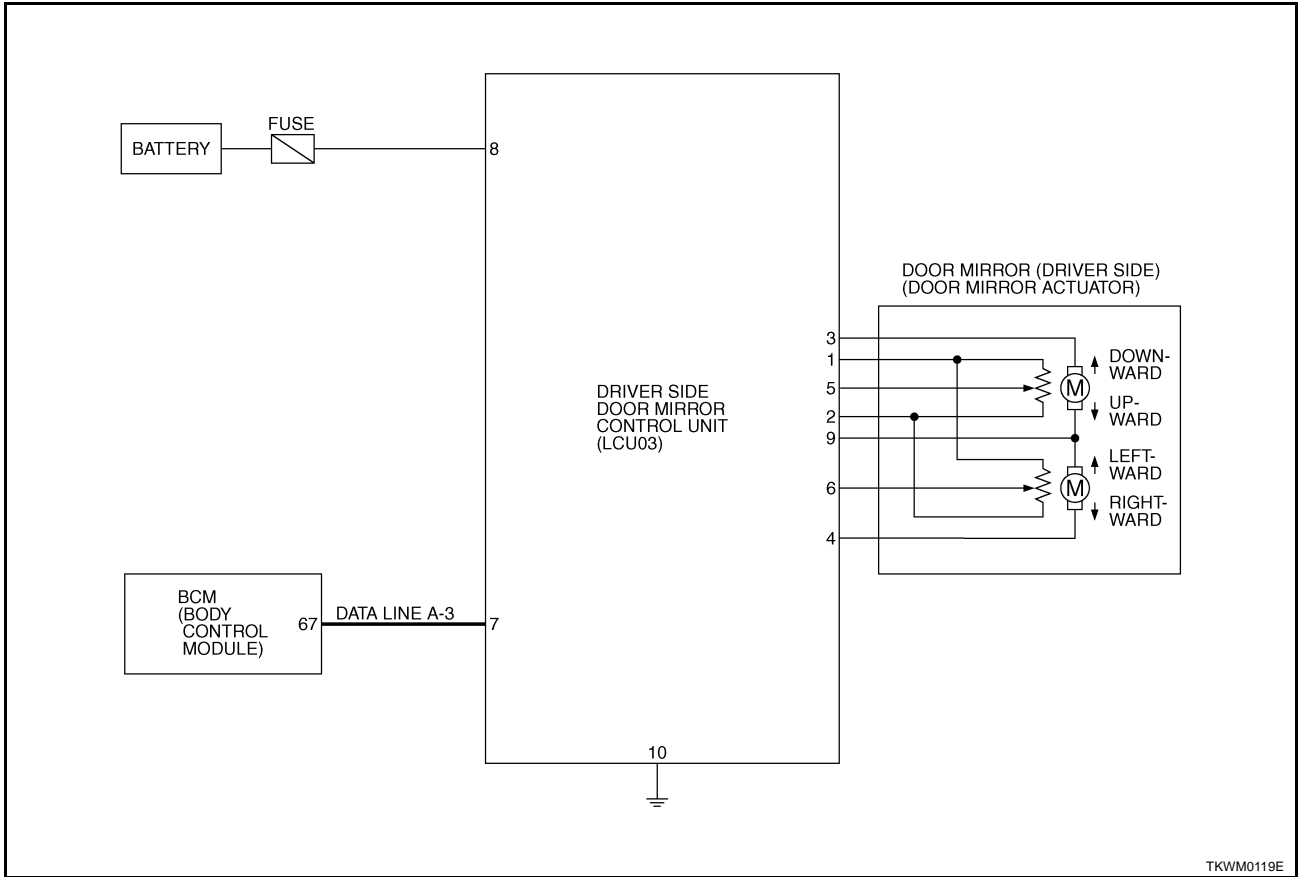

TKWM0119E

Schematic — LCU04 —

PASSENGER SIDE DOOR MIRROR CONTROL UNIT (WITH DOOR MIRROR MEMORY SYSTEM)

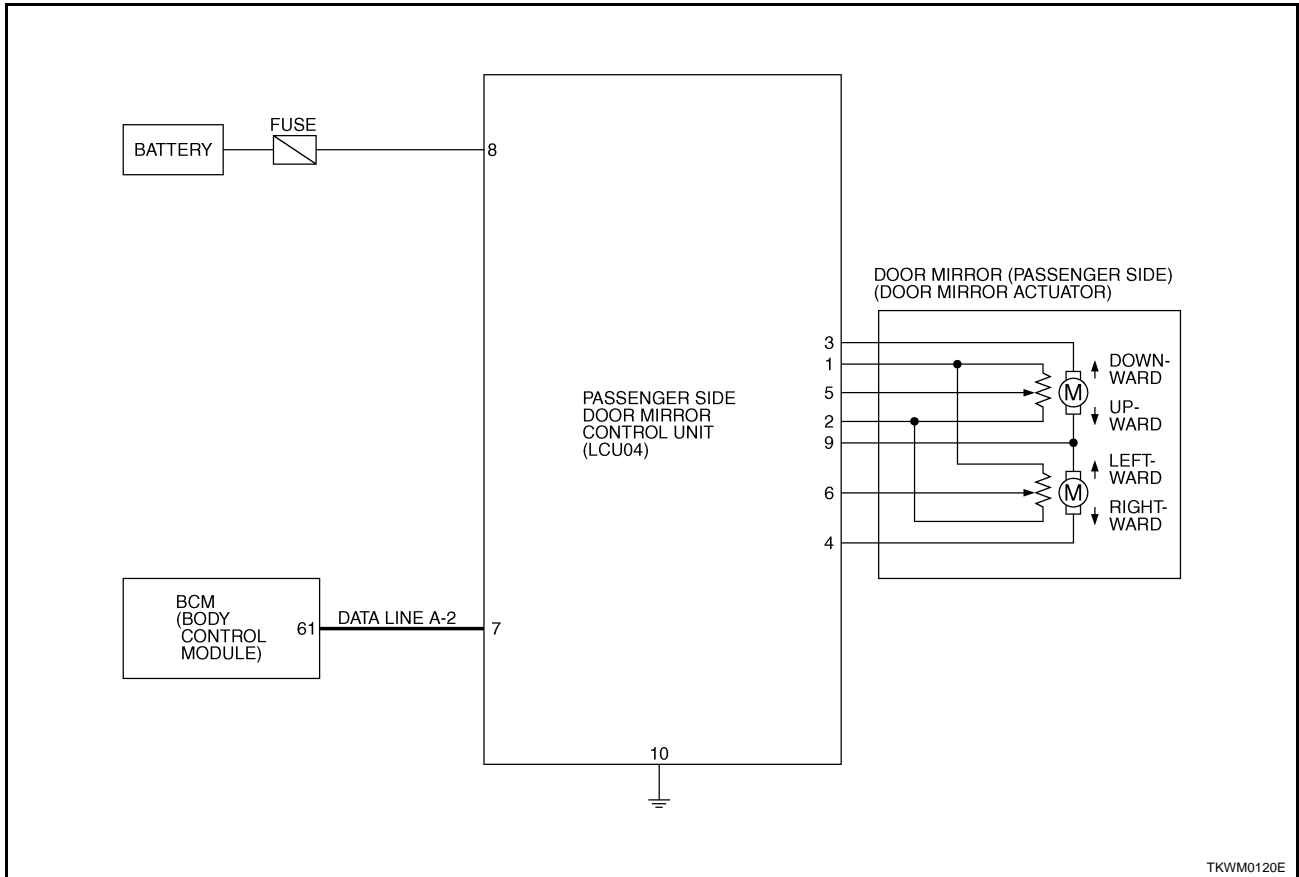

TKWM0120E

A
B
C
D
E
F
G
H
I
J
L
M

LAN

PRECAUTIONS

PF0:00001

Precautions for Supplemental Restraint System (SRS) “AIR BAG” and “SEAT BELT PRE-TENSIONER”

EKS001PQ

The Supplemental Restraint System such as “AIR BAG” and “SEAT BELT PRE-TENSIONER”, used along with a front seat belt, helps to reduce the risk or severity of injury to the driver and front passenger for certain types of collision. Information necessary to service the system safely is included in the SRS and SB section of this Service Manual.

WARNING:

- To avoid rendering the SRS inoperative, which could increase the risk of personal injury or death in the event of a collision which would result in air bag inflation, all maintenance must be performed by an authorized NISSAN/INFINITI dealer.
- Improper maintenance, including incorrect removal and installation of the SRS, can lead to personal injury caused by unintentional activation of the system. For removal of Spiral Cable and Air Bag Module, see the SRS section.
- Do not use electrical test equipment on any circuit related to the SRS unless instructed to in this Service Manual. SRS wiring harnesses can be identified by yellow and/or orange harnesses or harness connectors.

**Precautions For Trouble Diagnosis
CAN SYSTEM**

EKS001PR

- Do not apply voltage of 7.0V or higher to the measurement terminals.
- Use the tester with its open terminal voltage being 7.0V or less.

**Precautions For Harness Repair
CAN SYSTEM**

EKS001PS

- Solder the repaired parts, and wrap with tape. [Frays of twisted line must be within 110 mm (4.33 in)]

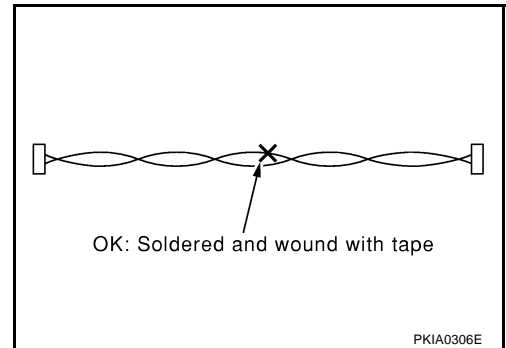

- Do not perform bypass wire connections for the repair parts. (The spliced wire will become separated and the characteristics of twisted line will be lost.)

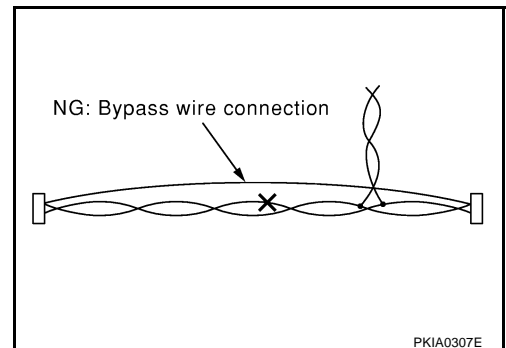

CAN COMMUNICATION

PFP:23710

System Description

EKS001PT

CAN (Controller Area Network) is a serial communication line for real time application. It is an on-vehicle multiplex communication line with high data communication speed and excellent error detection ability. Many electronic control units are equipped onto a vehicle, and each control unit shares information and links with other control units during operation (not independent). In CAN communication, control units are connected with 2 communication lines (CAN H line, CAN L line) allowing a high rate of information transmission with less wiring. Each control unit transmits/receives data but selectively reads required data only.

FOR VDC MODELS

System diagram

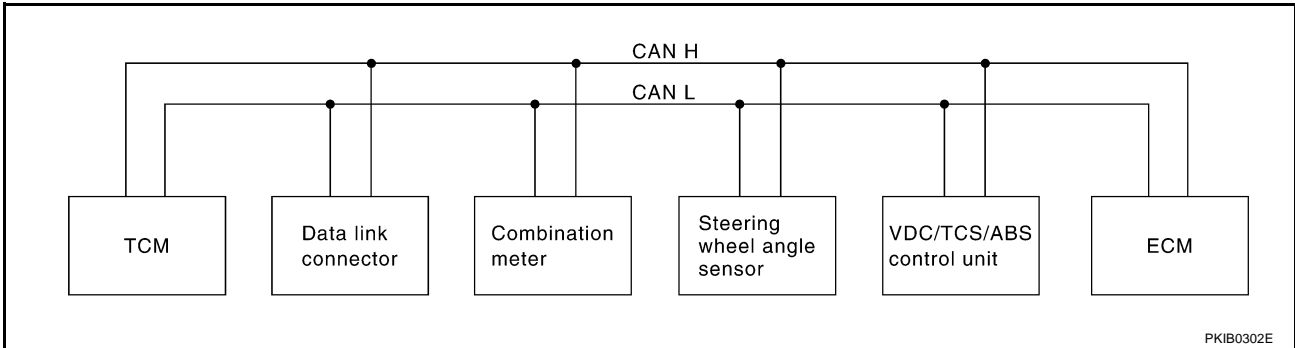

Input/output signal chart

T: Transmit R: Receive

Signals	TCM	Combination meter	Steering wheel angle sensor	VDC / TCS / ABS control unit	ECM
Engine speed signal	R	R		R	T
Engine coolant temperature signal	R	R			T
Accelerator pedal position signal	R			R	T
Engine torque signal	R			R	T
Battery voltage signal	R				T
Closed throttle position signal	R				T
Wide open throttle position signal	R				T
Lock-up prohibition signal	R				T
Torque-down permission signal	R				T
Fuel consumption monitor signal		R			T
Lock-up signal	T				R
Hard deceleration signal	T				R
Torque-down signal	T				R
Power mode indicator signal	T				R
A/T fluid temperature warning lamp signal	T	R			R
Current gear position signal	T	R		R	R
	R	T			
Next gear position signal	T			R	R
Shift change signal	T			R	R
Shift pattern signal	T				R
VDC system control signal				T	R
VDC operation signal				T	R
Stop lamp switch signal	R			T	
Steering wheel angle sensor signal	R		T	R	R

CAN COMMUNICATION

[CAN]

Signals	TCM	Combination meter	Steering wheel angle sensor	VDC / TCS / ABS control unit	ECM
Air conditioner switch signal		T			R
Headlamp switch signal		T			R
Rear window defogger switch signal		T			R
OD cancel switch signal	R	T		R	
Brake switch signal	R	T			
Power mode switch signal	R	T			
Vehicle speed signal	R	R		T	
	R	T			R
	T				R

FOR ICC MODELS

System diagram

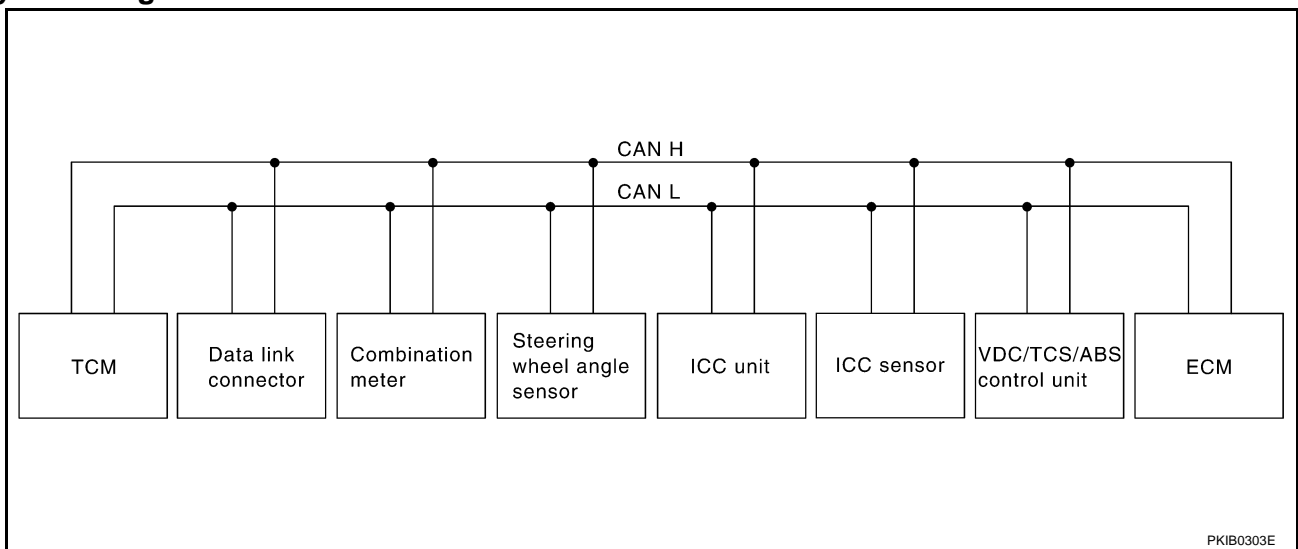

PKIB0303E

Input/output signal chart

T: Transmit R: Receive

Signals	TCM	Combina- tion meter	Steering wheel angle sensor	ICC unit	ICC sensor	VDC / TCS / ABS con- trol unit	ECM
ICC system display signal		R		T			
ICC sensor signal				R	T		
Engine speed signal	R	R		R		R	T
Engine coolant temperature signal	R	R					T
Accelerator pedal position signal	R					R	T
Engine torque signal	R					R	T
Battery voltage signal	R						T
Closed throttle position signal	R			R			T
Lock-up prohibition signal	R						T
Torque-down permission signal	R						T
Fuel consumption monitor signal		R					T
Lock-up signal	T						R
Hard deceleration signal	T						R
Torque-down signal	T						R

CAN COMMUNICATION

[CAN]

Signals	TCM	Combina- tion meter	Steering wheel angle sensor	ICC unit	ICC sensor	VDC / TCS / ABS con- trol unit	ECM
Power mode indicator signal	T						R
A/T fluid temperature warning lamp signal	T	R					R
Current gear position signal	T	R				R	R
	R	T					
Next gear position signal	T					R	R
Shift change signal	T					R	R
Shift pattern signal	T			R			R
VDC system control signal						T	R
VDC operation signal				R		T	R
Stop lamp switch signal	R					T	
Steering wheel angle sensor signal	R		T			R	R
Air conditioner switch signal		T					R
Headlamp switch signal		T					R
Rear window defogger switch signal		T					R
OD cancel switch signal	R	T				R	
Brake switch signal	R	T					
Power mode switch signal	R	T					
Vehicle speed signal	R	R		R		T	
	R	T					R
	T			R			R

A
B
C
D
E
F
G
H
I
J

LAN

L
M

CAN SYSTEM (FOR VDC MODELS)

PFP:47850

System Description

EKS003L7

CAN (Controller Area Network) is a serial communication line for real time application. It is an on-vehicle multiplex communication line with high data communication speed and excellent error detection ability. Many electronic control units are equipped onto a vehicle, and each control unit shares information and links with other control units during operation (not independent). In CAN communication, control units are connected with 2 communication lines (CAN H line, CAN L line) allowing a high rate of information transmission with less wiring. Each control unit transmits/receives data but selectively reads required data only.

Component Parts and Harness Connector Location

EKS003L8

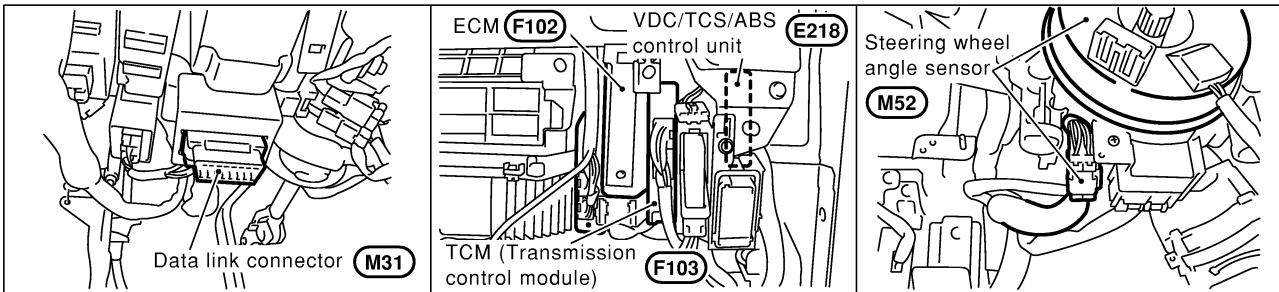

CKIM0011E

CAN SYSTEM (FOR VDC MODELS)

[CAN]

Wiring Diagram — CAN —

EKS003L9

LAN-CAN-01

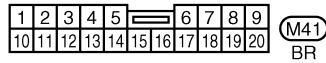
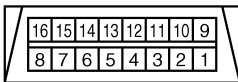
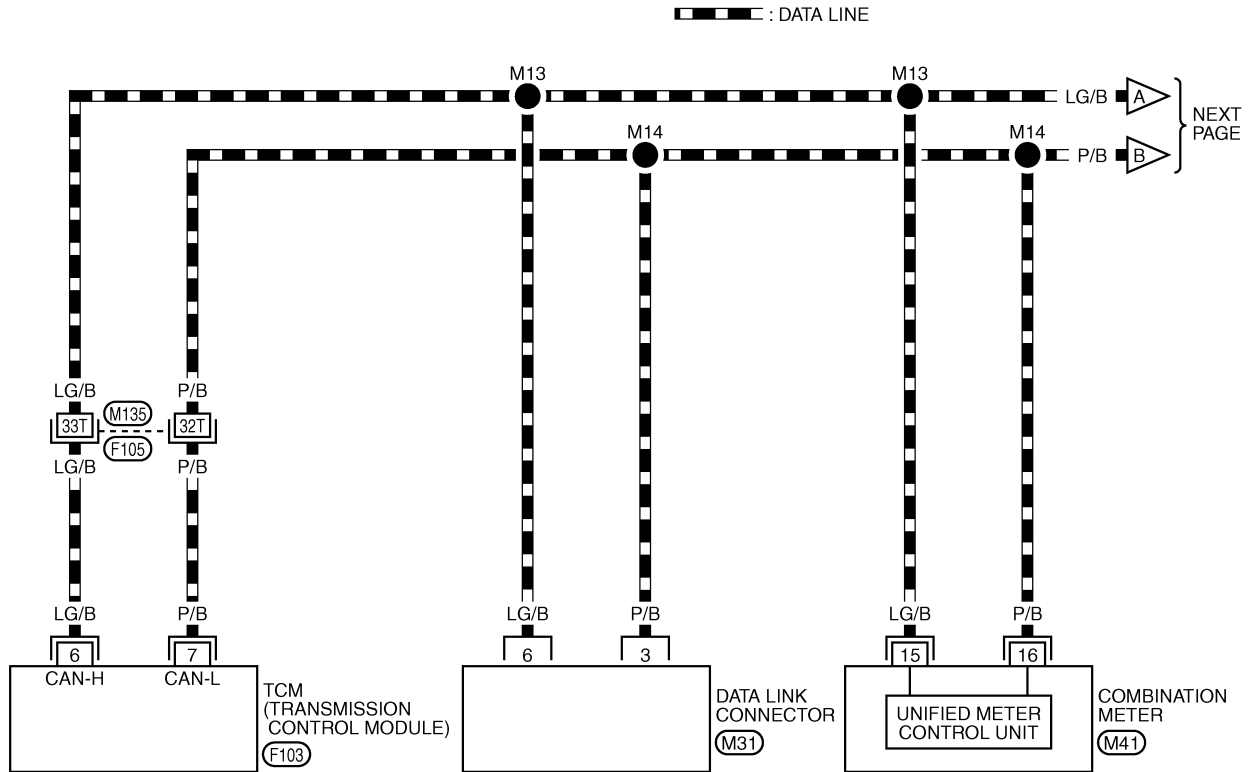

REFER TO THE FOLLOWING.

(F105) -SUPER MULTIPLE JUNCTION (SMJ)

(F103) -ELECTRICAL UNITS

A
B
C
D
E
F
G
H
I
J
LAN
L
M

TKWM0128E

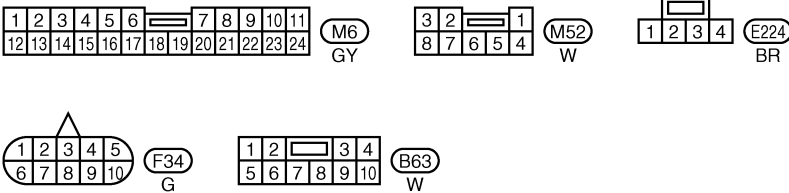
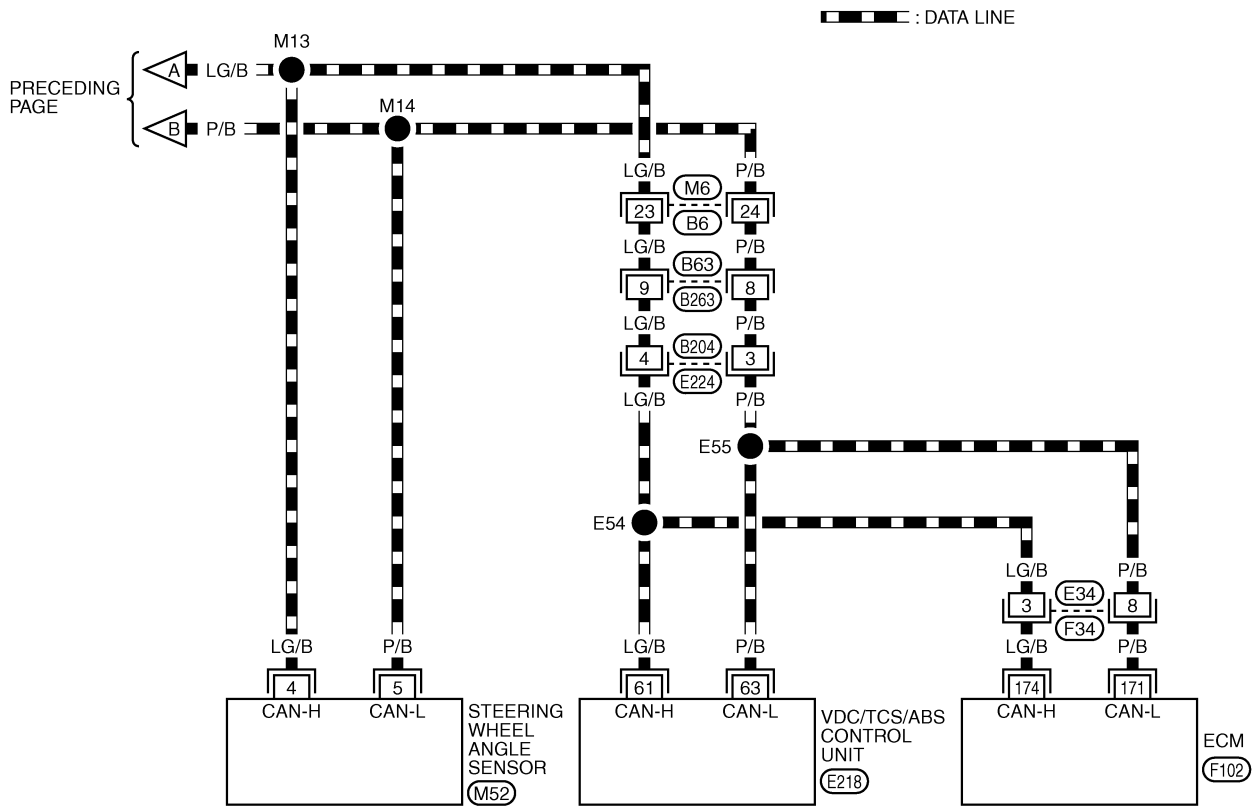

REFER TO THE FOLLOWING.
 (E218), (F102) - ELECTRICAL UNITS

TKWM0236E

CAN SYSTEM (FOR VDC MODELS)

[CAN]

EKS00HY4

Work Flow

1. Print all the data of "SELF-DIAG RESULTS" for "ENGINE", "VDC", and "A/T" displayed on CONSULT-II.

(Example)

SELECT DIAG MODE			
WORK SUPPORT			
SELF-DIAG RESULTS			
DATA MONITOR			
DATA MONITOR (SPEC)			
CAN DIAG SUPPORT MNTR			
ACTIVE TEST			
			Scroll Down
	BACK	LIGHT	COPY

SELF-DIAG RESULTS			
DTC RESULTS		TIME	
CAN COMM CIRCUIT [U1000]	0		
			F.F.DATA
ERASE		PRINT	
MODE	BACK	LIGHT	COPY

PKIA8260E

2. Print all the data of "CAN DIAG SUPPORT MNTR" for "ENGINE", "VDC", and "A/T" displayed on CONSULT-II.

(Example)

SELECT DIAG MODE			
WORK SUPPORT			
SELF-DIAG RESULTS			
DATA MONITOR			
DATA MONITOR (SPEC)			
CAN DIAG SUPPORT MNTR			
ACTIVE TEST			
			Scroll Down
	BACK	LIGHT	COPY

CAN DIAG SUPPORT MNTR			
ENGINE			
		PRSNT	
INITIAL DIAG	OK		
TRANSMIT DIAG	OK		
TCM	OK		
VDC/TCS/ABS	OK		
METER/M&A	OK		
ICC	UNKWN		
BCM/SEC	OK		
IPDM E/R	OK		
AWD/4WD/e4WD	UNKWN		
PRINT			Scroll Down
MODE	BACK	LIGHT	COPY

PKIA8343E

3. Attach the printed sheet of "SELF-DIAG RESULTS" and "CAN DIAG SUPPORT MNTR" onto the check sheet. Refer to [LAN-28. "CHECK SHEET"](#).
4. Based on the "CAN DIAG SUPPORT MNTR" results, put marks "v" onto the items with "NG" or "UNKWN" in the check sheet table. Refer to [LAN-28. "CHECK SHEET"](#).

NOTE:

If "NG" is displayed on "INITIAL DIAG (Initial diagnosis)" as "CAN DIAG SUPPORT MNTR" for the diagnosed control unit, replace the control unit.

5. According to the check sheet results (example), start inspection. Refer to [LAN-29. "CHECK SHEET RESULTS \(EXAMPLE\)"](#).

A
B
C
D
E
F
G
H
I
J
L
M

LAN

CAN SYSTEM (FOR VDC MODELS)

[CAN]

CHECK SHEET

NOTE:

If "NG" is displayed on "INITIAL DIAG (Initial diagnosis)" as "CAN DIAG SUPPORT MNTR" for the diagnosed control unit, replace the control unit.

Check sheet table

SELECT SYSTEM screen	CAN DIAG SUPPORT MNTR						
	Initial diagnosis	Transmit diagnosis	Receive diagnosis				
			ECM	VDC/TCS /ABS	STRG	METER /M&A	TCM
ENGINE	NG	UNKWN	—	UNKWN	—	UNKWN	UNKWN
VDC	NG	UNKWN	UNKWN	—	UNKWN	UNKWN	UNKWN
A/T	NG	UNKWN	UNKWN	UNKWN	—	UNKWN	—

Symptoms :

Attach copy of
ENGINE
SELF-DIAG RESULTS

Attach copy of
VDC
SELF-DIAG RESULTS

Attach copy of
A/T
SELF-DIAG RESULTS

Attach copy of
ENGINE
CAN DIAG SUPPORT
MNTR

Attach copy of
VDC
CAN DIAG SUPPORT
MNTR

Attach copy of
A/T
CAN DIAG SUPPORT
MNTR

CAN SYSTEM (FOR VDC MODELS)

[CAN]

CHECK SHEET RESULTS (EXAMPLE)

NOTE:

If "NG" is displayed on "INITIAL DIAG (Initial diagnosis)" as "CAN DIAG SUPPORT MNTR" for the diagnosed control unit, replace the control unit.

Case 1

Check harness between VDC/TCS/ABS control unit and steering wheel angle sensor. Refer to [LAN-32, "Circuit Check Between VDC/TCS/ABS Control Unit and Steering Wheel Angle Sensor"](#).

SELECT SYSTEM screen	CAN DIAG SUPPORT MNTR						
	Initial diagnosis	Transmit diagnosis	Receive diagnosis				
			ECM	VDC/TCS /ABS	STRG	METER /M&A	TCM
ENGINE	NG	UNKWN	—	UNKWN	—	UNKWN	UNKWN
VDC	NG	UNKWN	UNKWN	—	UNKWN	UNKWN	UNKWN
A/T	NG	UNKWN	UNKWN	UNKWN	—	UNKWN	—

PKIA8655E

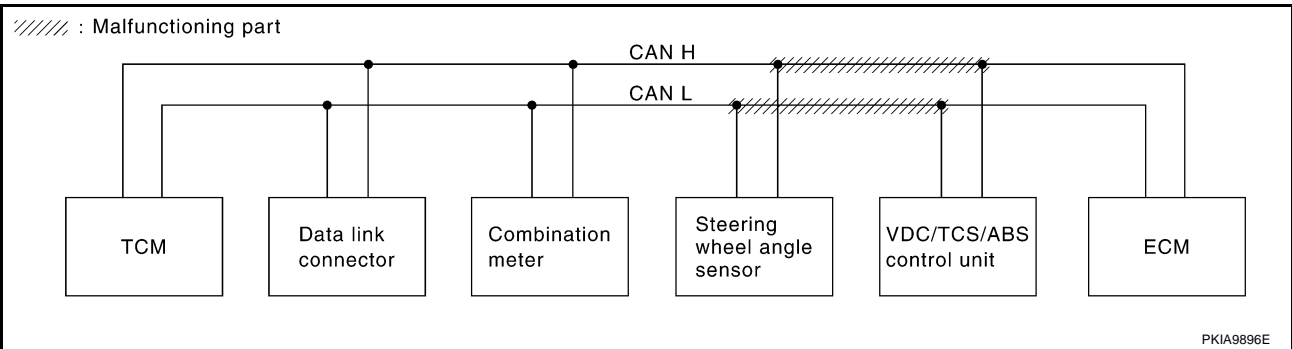

Case 2

Check harness between steering wheel angle sensor and combination meter. Refer to [LAN-34, "Circuit Check Between Steering Wheel Angle Sensor and Combination Meter"](#).

SELECT SYSTEM screen	CAN DIAG SUPPORT MNTR						
	Initial diagnosis	Transmit diagnosis	Receive diagnosis				
			ECM	VDC/TCS /ABS	STRG	METER /M&A	TCM
ENGINE	NG	UNKWN	—	UNKWN	—	UNKWN	UNKWN
VDC	NG	UNKWN	UNKWN	—	UNKWN	UNKWN	UNKWN
A/T	NG	UNKWN	UNKWN	UNKWN	—	UNKWN	—

PKIA8656E

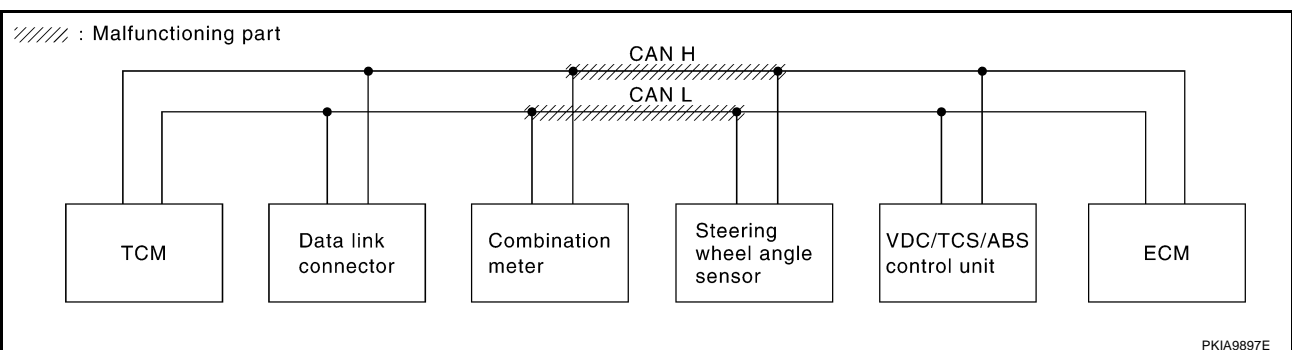

A
B
C
D
E
F
G
H
I
J
K
L
M

LAN

CAN SYSTEM (FOR VDC MODELS)

[CAN]

Case 3

Check ECM circuit. Refer to [LAN-34, "ECM Circuit Check"](#) .

SELECT SYSTEM screen	CAN DIAG SUPPORT MNTR						
	Initial diagnosis	Transmit diagnosis	Receive diagnosis				
			ECM	VDC/TCS /ABS	STRG	METER /M&A	TCM
ENGINE	NG	UNKW N	—	UNKW N	—	UNKW N	UNKW N
VDC	NG	UNKW N	UNKW N	—	UNKW N	UNKW N	UNKW N
A/T	NG	UNKW N	UNKW N	UNKW N	—	UNKW N	—

PKIA8657E

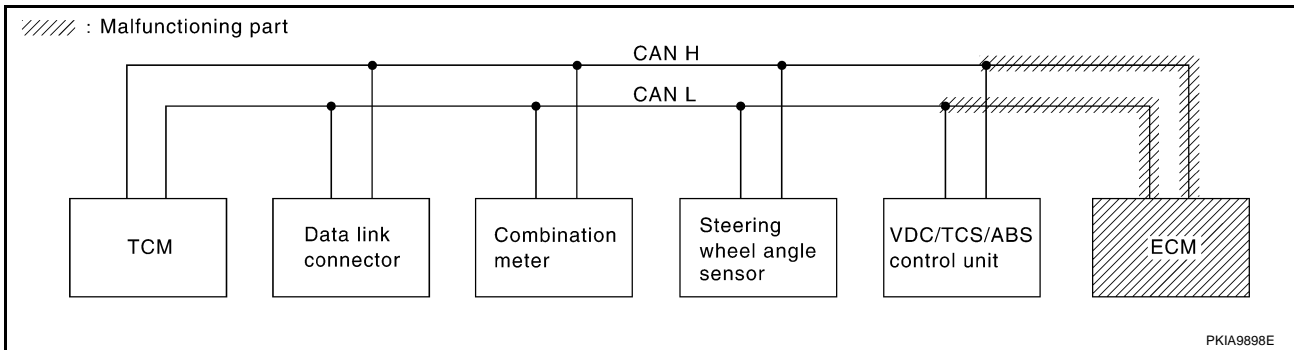

Case 4

Check VDC/TCS/ABS control unit circuit. Refer to [LAN-35, "VDC/TCS/ABS Control Unit Circuit Check"](#) .

SELECT SYSTEM screen	CAN DIAG SUPPORT MNTR						
	Initial diagnosis	Transmit diagnosis	Receive diagnosis				
			ECM	VDC/TCS /ABS	STRG	METER /M&A	TCM
ENGINE	NG	UNKW N	—	UNKW N	—	UNKW N	UNKW N
VDC	NG	UNKW N	UNKW N	—	UNKW N	UNKW N	UNKW N
A/T	NG	UNKW N	UNKW N	UNKW N	—	UNKW N	—

PKIA8658E

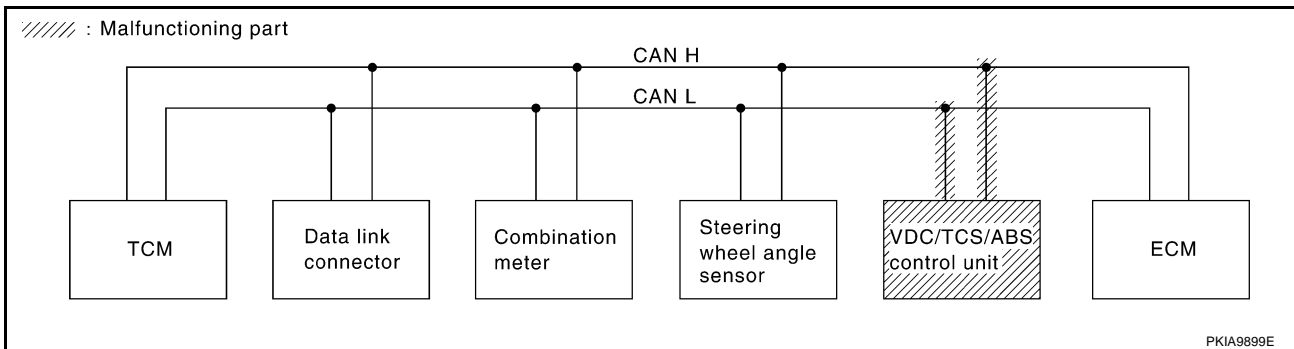

CAN SYSTEM (FOR VDC MODELS)

[CAN]

Case 5

Check steering wheel angle sensor circuit. Refer to [LAN-35, "Steering Wheel Angle Sensor Circuit Check"](#) .

SELECT SYSTEM screen	CAN DIAG SUPPORT MNTR						
	Initial diagnosis	Transmit diagnosis	Receive diagnosis				
			ECM	VDC/TCS /ABS	STRG	METER /M&A	TCM
ENGINE	NG	UNKWN	—	UNKWN	—	UNKWN	UNKWN
VDC	NG	UNKWN	UNKWN	—	UNKWN ✓	UNKWN	UNKWN
A/T	NG	UNKWN	UNKWN	UNKWN	—	UNKWN	—

PKIA8659E

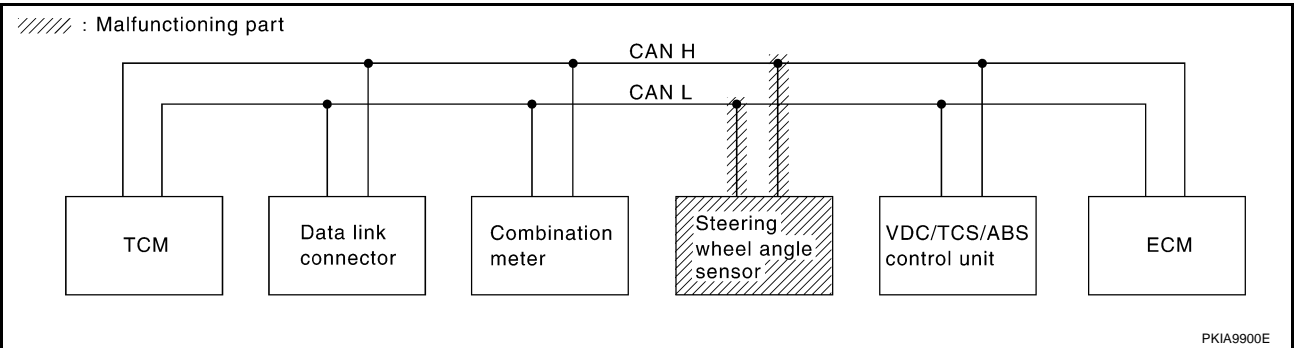

Case 6

Check combination meter circuit. Refer to [LAN-36, "Combination Meter Circuit Check"](#) .

SELECT SYSTEM screen	CAN DIAG SUPPORT MNTR						
	Initial diagnosis	Transmit diagnosis	Receive diagnosis				
			ECM	VDC/TCS /ABS	STRG	METER /M&A	TCM
ENGINE	NG	UNKWN	—	UNKWN	—	UNKWN ✓	UNKWN
VDC	NG	UNKWN	UNKWN	—	UNKWN	UNKWN ✓	UNKWN
A/T	NG	UNKWN	UNKWN	UNKWN	—	UNKWN ✓	—

PKIA8660E

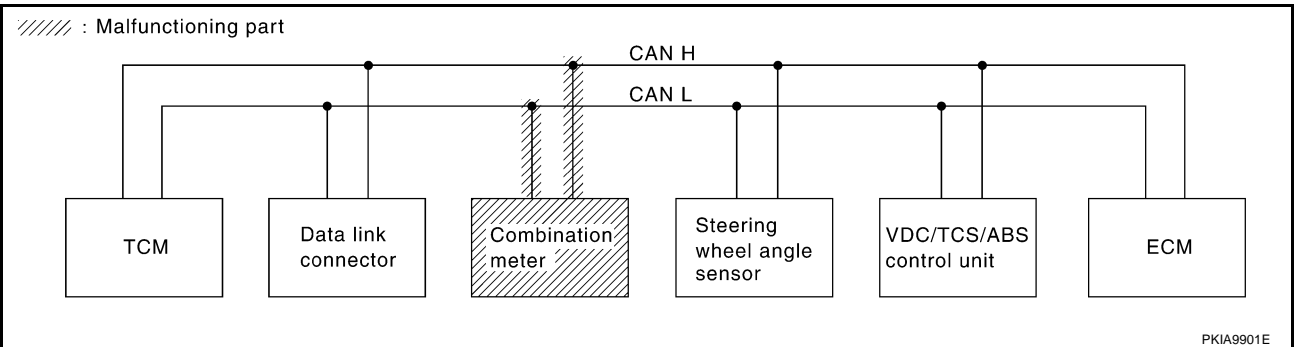

A
B
C
D
E
F
G
H
I
J
K
L
M

LAN

Case 7

Check TCM circuit. Refer to [LAN-36, "TCM Circuit Check"](#) .

SELECT SYSTEM screen	CAN DIAG SUPPORT MNTR						
	Initial diagnosis	Transmit diagnosis	Receive diagnosis				
			ECM	VDC/TCS /ABS	STRG	METER /M&A	TCM
ENGINE	NG	UNKWN	—	UNKWN	—	UNKWN	UNKWN ✓
VDC	NG	UNKWN	UNKWN	—	UNKWN	UNKWN	UNKWN ✓
A/T	NG	UNKWN ✓	UNKWN ✓	UNKWN ✓	—	UNKWN ✓	—

PKIA8661E

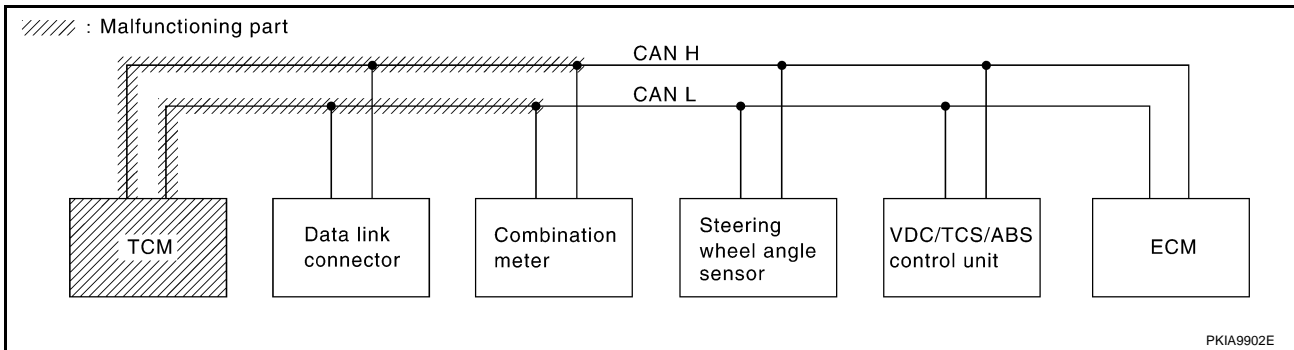

Case 8

Check CAN communication circuit. Refer to [LAN-37, "CAN Communication Circuit Check"](#) .

SELECT SYSTEM screen	CAN DIAG SUPPORT MNTR						
	Initial diagnosis	Transmit diagnosis	Receive diagnosis				
			ECM	VDC/TCS /ABS	STRG	METER /M&A	TCM
ENGINE	NG	UNKWN ✓	—	UNKWN ✓	—	UNKWN ✓	UNKWN ✓
VDC	NG	UNKWN ✓	UNKWN ✓	—	UNKWN ✓	UNKWN ✓	UNKWN ✓
A/T	NG	UNKWN ✓	UNKWN ✓	UNKWN ✓	—	UNKWN ✓	—

PKIA8662E

Circuit Check Between VDC/TCS/ABS Control Unit and Steering Wheel Angle Sensor

EKS003LB

1. CHECK CONNECTOR

1. Turn ignition switch OFF.
2. Check following terminals and connector for damage, bend and loose connection.(control unit-side, sensor-side and harness-side)
 - VDC/TCS/ABS control unit.
 - Steering wheel angle sensor.
 - Between VDC/TCS/ABS control unit and steering wheel angle sensor.

OK or NG

- OK >> GO TO 2.
 NG >> Repair terminal or connector.

2. CHECK HARNESS FOR OPEN CIRCUIT

1. Disconnect VDC/TCS/ABS control unit connector and harness connector E224.
2. Check continuity between VDC/TCS/ABS control unit harness connector E218 terminals 61 (LG/B), 63 (P/B) and harness connector E224 terminals 4 (LG/B), 3 (P/B).

61 (LG/B) – 4 (LG/B) : Continuity should exist.
63 (P/B) – 3 (P/B) : Continuity should exist.

OK or NG

- OK >> GO TO 3.
 NG >> Repair harness.

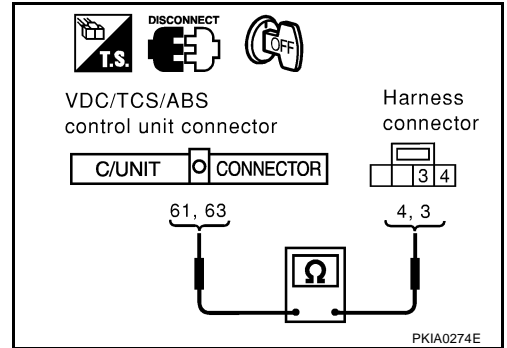

3. CHECK HARNESS FOR OPEN CIRCUIT

1. Disconnect harness connector B263.
2. Check continuity between harness connector B204 terminals 4 (LG/B), 3 (P/B) and harness connector B263 terminals 9 (LG/B), 8 (P/B).

4 (LG/B) – 9(LG/B) : Continuity should exist.
3(P/B) – 8(P/B) : Continuity should exist.

OK or NG

- OK >> GO TO 4.
 NG >> Repair harness.

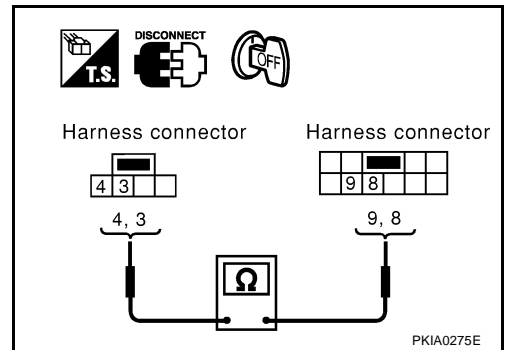

4. CHECK HARNESS FOR OPEN CIRCUIT

1. Disconnect harness connector B6.
2. Check continuity between harness connector B63 terminals 9(LG/B), 8 (P/B) and harness connector B6 terminals 23(LG/B), 24 (P/B).

9(LG/B) – 23(LG/B) : Continuity should exist.
8(P/B) – 24(P/B) : Continuity should exist.

OK or NG

- OK >> GO TO 5.
 NG >> Repair harness.

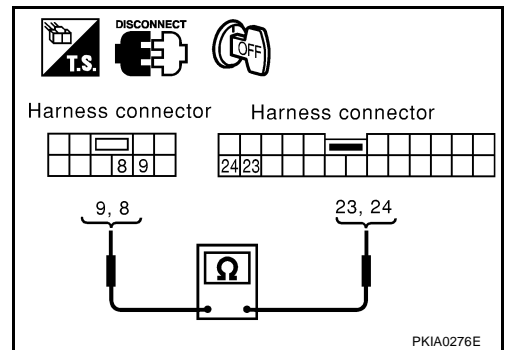

5. CHECK HARNESS FOR OPEN CIRCUIT

1. Disconnect steering wheel angle sensor connector.
2. Check continuity between harness connector M6 terminals 23(LG/B), 24 (P/B) and steering wheel angle sensor harness connector M52 terminals 4 (LG/B), 5 (P/B).

23(LG/B) – 4(LG/B) : Continuity should exist.
24(P/B) – 5(P/B) : Continuity should exist.

OK or NG

- OK >> Connect all the connectors and diagnose again. Refer to [LAN-27, "Work Flow"](#) .
 NG >> Repair harness.

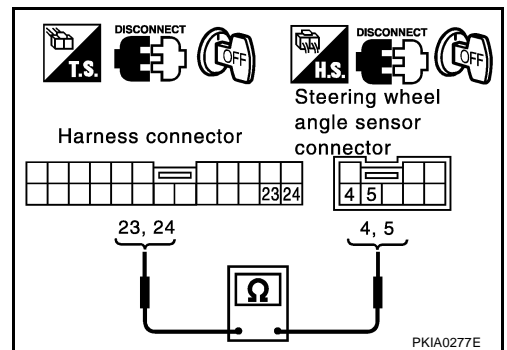

Circuit Check Between Steering Wheel Angle Sensor and Combination Meter

EKS003LC

1. CHECK CONNECTOR

1. Turn ignition switch OFF.
2. Check following terminals and connector for damage, bend and loose connection. (sensor-side, meter-side and harness-side)
 - Steering wheel angle sensor.
 - Combination meter.

OK or NG

- OK >> GO TO 2.
 NG >> Repair terminal or connector.

2. CHECK HARNESS FOR OPEN CIRCUIT

1. Disconnect steering wheel angle sensor connector and combination meter connector.
2. Check continuity between steering wheel angle sensor harness connector M52 terminals 4 (LG/B), 5 (P/B) and combination meter harness connector M41 terminals 15(LG/B), 16 (P/B).

4(LG/B) – 15(LG/B) : Continuity should exist.
5(P/B) – 16(P/B) : Continuity should exist.

OK or NG

- OK >> Connect all the connectors and diagnose again. Refer to [LAN-27, "Work Flow"](#) .
 NG >> Repair harness.

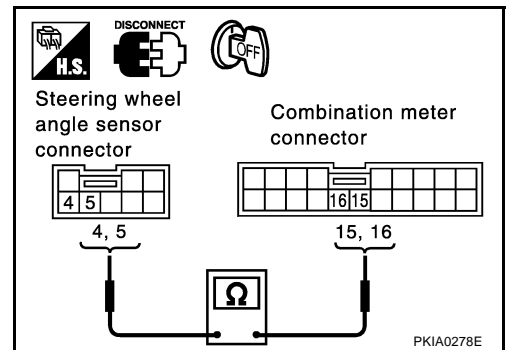

EKS003LD

ECM Circuit Check

1. CHECK CONNECTOR

1. Turn ignition switch OFF.
2. Check following terminals and connector for damage, bend and loose connection. (control module-side and harness-side)
 - ECM.
 - Harness connector F34.
 - Harness connector E34.

OK or NG

- OK >> GO TO 2.
 NG >> Repair terminal or connector.

2. CHECK HARNESS FOR OPEN CIRCUIT

1. Disconnect ECM connector.
2. Check resistance between ECM harness connector F102 terminals 174(LG/B) and 171(P/B).

174(LG/B) – 171(P/B) : Approx. 108 – 132Ω

OK or NG

- OK >> Replace ECM.
 NG >> Repair harness between splice points E54, E55 and ECM.

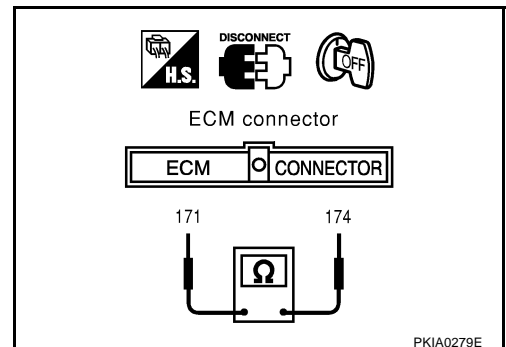

VDC/TCS/ABS Control Unit Circuit Check

EKS003LE

1. CHECK CONNECTOR

1. Turn ignition switch OFF.
2. Check the terminals and connector of VDC/TCS/ABS control unit for damage, bend and loose connection. (control unit-side and harness-side)

OK or NG

- OK >> GO TO 2.
 NG >> Repair terminal or connector.

2. CHECK HARNESS FOR OPEN CIRCUIT

1. Disconnect VDC/TCS/ABS control unit connector.
2. Check resistance between VDC/TCS/ABS control unit harness connector E218 terminals 61(LG/B) and 63(P/B).

61(LG/B) – 63(P/B) : Approx. 54 – 66Ω

OK or NG

- OK >> Replace VDC/TCS/ABS control unit.
 NG >> Repair harness between splice points E54, E55 and VDC/TCS/ABS control unit.

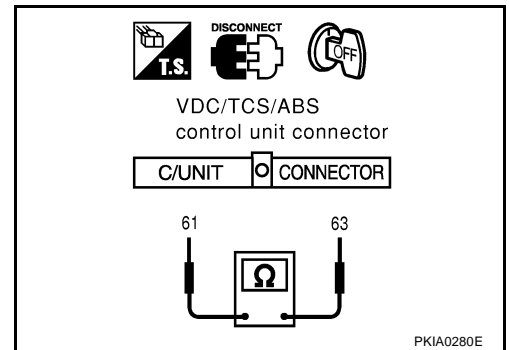

Steering Wheel Angle Sensor Circuit Check

EKS003LF

1. CHECK CONNECTOR

1. Turn ignition switch OFF.
2. Check the terminals and connector of steering wheel angle sensor for damage, bend and loose connection. (sensor-side and harness-side)

OK or NG

- OK >> GO TO 2.
 NG >> Repair terminal or connector.

2. CHECK HARNESS FOR OPEN CIRCUIT

1. Disconnect steering wheel angle sensor connector.
2. Check resistance between steering wheel angle sensor harness connector M52 terminals 4(LG/B) and 5(P/B).

4(LG/B) – 5(P/B) : Approx. 54 – 66Ω

OK or NG

- OK >> Replace steering wheel angle sensor.
 NG >> Repair harness between splice points M13, M14 and steering wheel angle sensor.

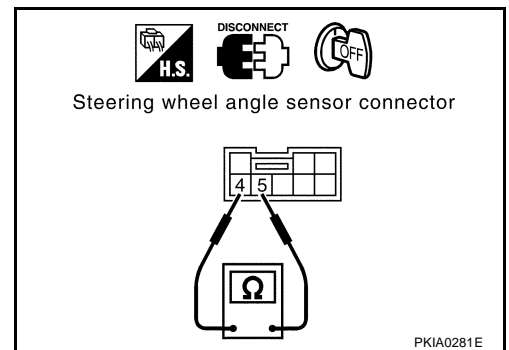

Combination Meter Circuit Check

1. CHECK CONNECTOR

1. Turn ignition switch OFF.
2. Check terminals and connector of combination meter for damage, bend and loose connection.(meter-side and harness-side)

OK or NG

- OK >> GO TO 2.
 NG >> Repair terminal or connector.

2. CHECK HARNESS FOR OPEN CIRCUIT

1. Disconnect combination meter connector.
2. Check resistance between combination meter harness connector M41 terminals 15 (LG/B) and 16 (P/B).

15(LG/B) – 16(P/B) : Approx. 54 – 66Ω

OK or NG

- OK >> Replace combination meter.
 NG >> Repair harness between splice points M13, M14 and combination meter.

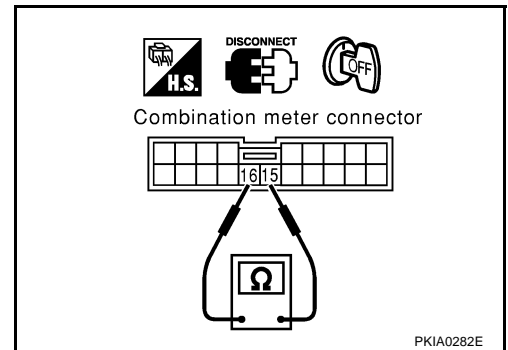

TCM Circuit Check

1. CHECK CONNECTOR

1. Turn ignition switch OFF.
2. Check following terminals and connector for damage, bend and loose connection.(control module-side and harness-side)

- TCM.
- Harness connector F105.
- Harness connector M135.

OK or NG

- OK >> GO TO 2.
 NG >> Repair terminal or connector.

2. CHECK HARNESS FOR OPEN CIRCUIT

1. Disconnect TCM connector.
2. Check resistance between TCM harness connector F103 terminals 6 (LG/B) and 7(P/B).

6(LG/B) – 7(P/B) : Approx. 108 – 132Ω

OK or NG

- OK >> Replace TCM.
 NG >> Repair harness between splice points M13, M14 and TCM.

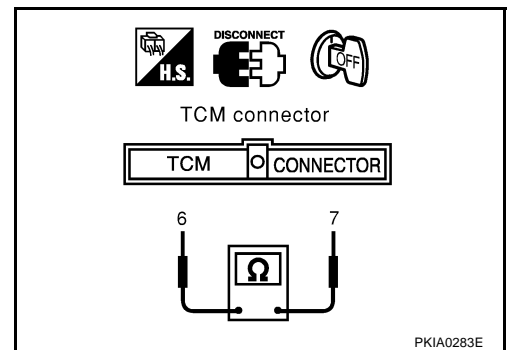

CAN Communication Circuit Check

1. CHECK CONNECTOR

1. Turn ignition switch OFF.
2. Check following terminals and connector for damage, bend and loose connection.(control module-side, control unit-side, meter-side, sensor-side and harness-side)
 - TCM.
 - Combination meter.
 - Steering wheel angle sensor.
 - VDC/TCS/ABS control unit.
 - ECM.
 - Between TCM and ECM.

OK or NG

- OK >> GO TO 2.
 NG >> Repair terminal or connector.

2. CHECK HARNESS FOR SHORT CIRCUIT

1. Disconnect TCM connector and harness connector F105.
2. Check continuity between TCM harness connector F103 terminals 6 (LG/B) and 7(P/B).

6(LG/B) – 7(P/B) : Continuity should not exist.

OK or NG

- OK >> GO TO 3.
 NG >> Repair harness between TCM and harness connector F105.

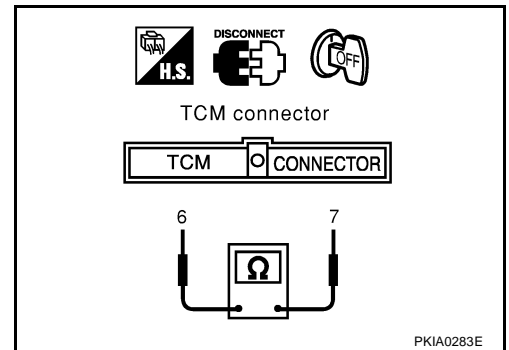

3. CHECK HARNESS FOR SHORT CIRCUIT

Check continuity between TCM harness connector F103 terminals 6 (LG/B), 7 (P/B) and ground.

6(LG/B) – ground : Continuity should not exist.

7(P/B) – ground : Continuity should not exist.

OK or NG

- OK >> GO TO 4.
 NG >> Repair harness between TCM and harness connector F105.

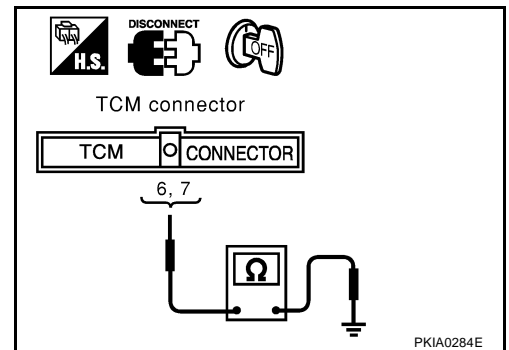

A
B
C
D
E
F
G
H
I
J
LAN
L
M

4. CHECK HARNESS FOR SHORT CIRCUIT

1. Disconnect combination meter connector, steering wheel angle sensor connector and harness connector M6.
2. Check continuity between Data Link Connector M31 terminals 6 (LG/B) and 3(P/B).

6(LG/B) – 3(P/B) : Continuity should not exist.

OK or NG

OK >> GO TO 5.

NG >> ● Repair harness between harness connector M6 and harness connector M135.

- Repair harness between splice points M13, M14 and Data Link Connector.
- Repair harness between splice points M13, M14 and combination meter.
- Repair harness between splice points M13, M14 and steering wheel angle sensor.

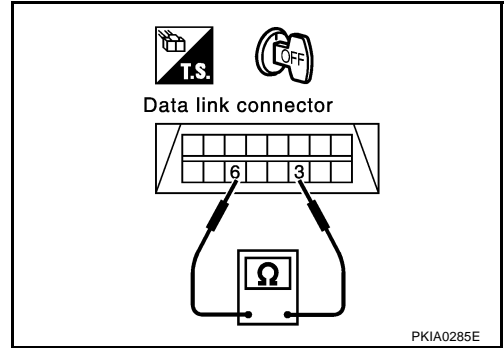

5. CHECK HARNESS FOR SHORT CIRCUIT

Check continuity between Data Link Connector M31 terminals 6 (LG/B), 3(P/B) and ground.

6(LG/B) – ground : Continuity should not exist.

3(P/B) – ground : Continuity should not exist.

OK or NG

OK >> GO TO 6.

NG >> ● Repair harness between harness connector M6 and harness connector M135.

- Repair harness between splice points M13, M14 and Data Link Connector.
- Repair harness between splice points M13, M14 and combination meter.
- Repair harness between splice points M13, M14 and steering wheel angle sensor.

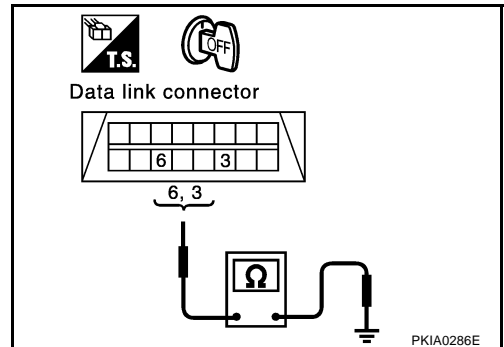

6. CHECK HARNESS FOR SHORT CIRCUIT

1. Disconnect harness connector B63.
2. Check continuity between harness connector B6 terminals 23(LG/B) and 24(P/B).

23(LG/B) – 24(P/B) : Continuity should not exist.

OK or NG

OK >> GO TO 7.

NG >> Repair harness between harness connector B6 and harness connector B63.

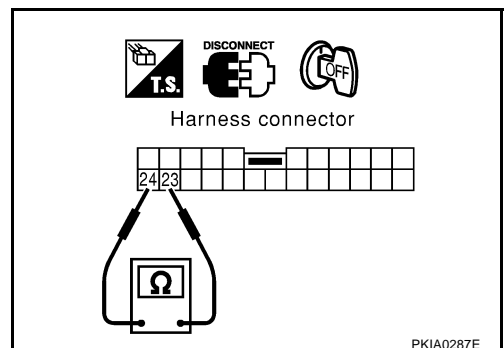

7. CHECK HARNESS FOR SHORT CIRCUIT

Check continuity between harness connector B6 terminals 23(LG/B), 24(P/B) and ground.

23(LG/B) – ground : Continuity should not exist.

24(P/B) – ground : Continuity should not exist.

OK or NG

OK >> GO TO 8.

NG >> Repair harness between harness connector B6 and harness connector B63.

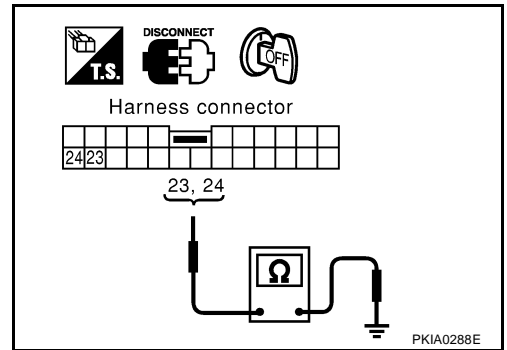

8. CHECK HARNESS FOR SHORT CIRCUIT

1. Disconnect harness connector B204.
2. Check continuity between harness connector B263 terminals 9(LG/B) and 8(P/B).

9(LG/B) – 8(P/B) : Continuity should not exist.

OK or NG

OK >> GO TO 9.

NG >> Repair harness between harness connector B263 and harness connector B204.

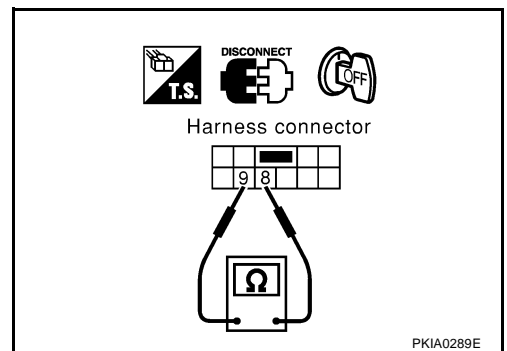

9. CHECK HARNESS FOR SHORT CIRCUIT

Check continuity between harness connector B263 terminals 9(LG/B), 8(P/B) and ground.

9(LG/B) – ground : Continuity should not exist.

8(P/B) – ground : Continuity should not exist.

OK or NG

OK >> GO TO 10.

NG >> Repair harness between harness connector B263 and harness connector B204.

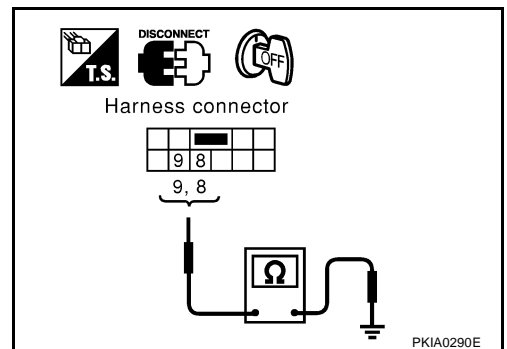

10. CHECK HARNESS FOR SHORT CIRCUIT

1. Disconnect VDC/TCS/ABS control unit connector and harness connector E34.
2. Check continuity between VDC/TCS/ABS control unit harness connector E218 terminals 61 (LG/B) and 63(P/B).

61(LG/B) – 63(P/B) : Continuity should not exist.

OK or NG

OK >> GO TO 11.

- NG >>
- Repair harness between harness connector E34 and harness connector E224.
 - Repair harness between splice points E54, E55 and VDC/TCS/ABS control unit.

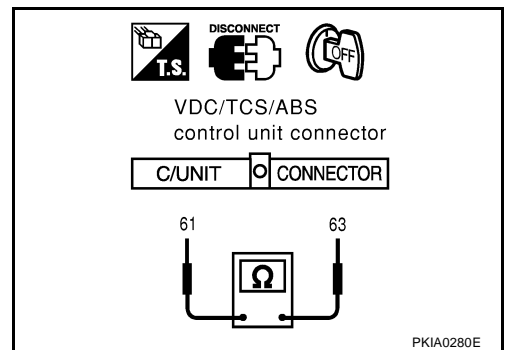

11. CHECK HARNESS FOR SHORT CIRCUIT

Check continuity between VDC/TCS/ABS control unit harness connector E218 terminals 61 (LG/B), 63(P/B) and ground.

- 61(LG/B) – ground : Continuity should not exist.**
- 63(P/B) – ground : Continuity should not exist.**

OK or NG

- OK >> GO TO 12.
- NG >>
 - Repair harness between harness connector E34 and harness connector E224.
 - Repair harness between splice points E54, E55 and VDC/TCS/ABS control unit.

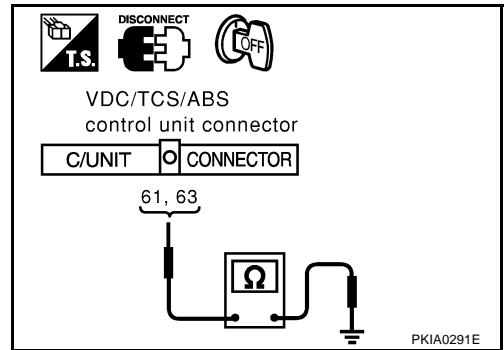

12. CHECK HARNESS FOR SHORT CIRCUIT

1. Disconnect ECM connector.
2. Check continuity between ECM harness connector F102 terminals 174 (LG/B) and 171(P/B).

- 174(LG/B) – 171(P/B) : Continuity should not exist.**

OK or NG

- OK >> GO TO 13.
- NG >> Repair harness between ECM and harness connector F34.

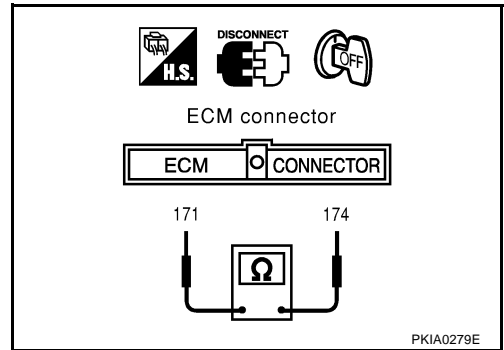

13. CHECK HARNESS FOR SHORT CIRCUIT

Check continuity between ECM harness connector F102 terminals 174 (LG/B), 171 (P/B) and ground.

- 174(LG/B) – ground : Continuity should not exist.**
- 171(P/B) – ground : Continuity should not exist.**

OK or NG

- OK >> GO TO 14.
- NG >> Repair harness between ECM and harness connector F34.

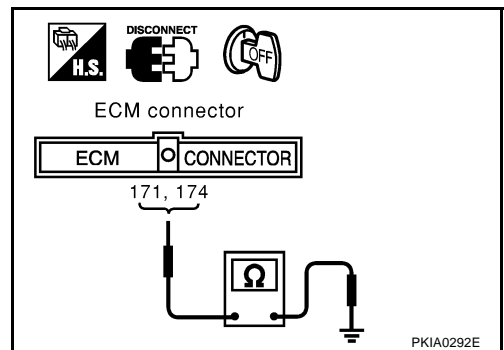

14. ECM/TCM INTERNAL CIRCUIT INSPECTION

Check components inspection. Refer to [LAN-41, "ECM/TCM INTERNAL CIRCUIT INSPECTION"](#)

OK or NG

- OK >> Connect all the connectors and diagnose again. Refer to [LAN-27, "Work Flow"](#).
- NG >> Replace ECM and/or TCM.

EKS003LJ

Component Inspection ECM/TCM INTERNAL CIRCUIT INSPECTION

- Remove ECM and TCM from vehicle.
- Check resistance between ECM terminals 174 and 171.
- Check resistance between TCM terminals 6 and 7.

Unit	Terminal	Resistance value (Ω)
ECM	174 - 171	Approx. 108 - 132
TCM	6 - 7	

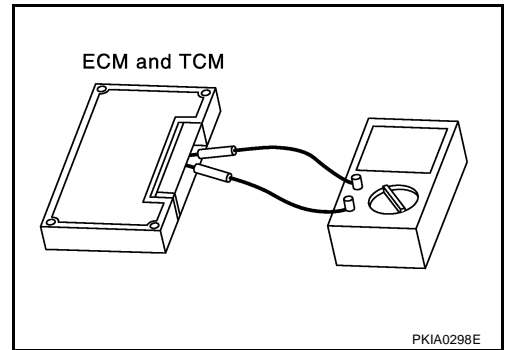

A
B
C
D
E
F
G
H
I
J
L
M

LAN

CAN SYSTEM (FOR ICC MODELS)

PFP:18995

System Description

EKS003LX

CAN (Controller Area Network) is a serial communication line for real time application. It is an on-vehicle multiplex communication line with high data communication speed and excellent error detection ability. Many electronic control units are equipped onto a vehicle, and each control unit shares information and links with other control units during operation (not independent). In CAN communication, control units are connected with 2 communication lines (CAN H line, CAN L line) allowing a high rate of information transmission with less wiring. Each control unit transmits/receives data but selectively reads required data only.

Component Parts and Harness Connector Location

EKS003LY

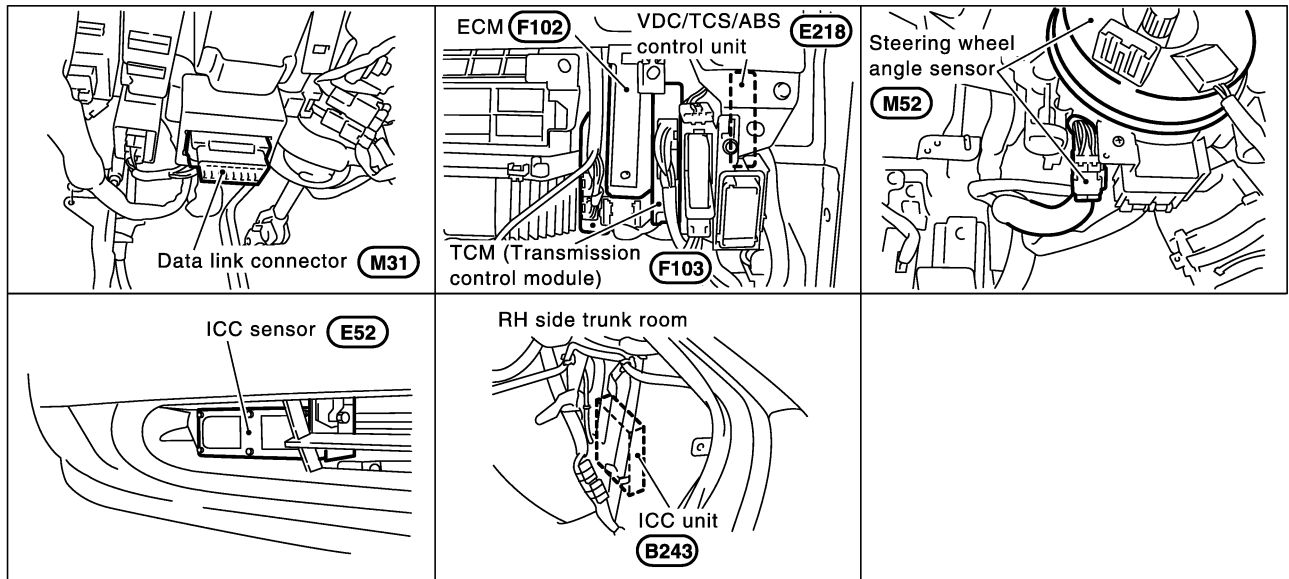

SKIA1245E

CAN SYSTEM (FOR ICC MODELS)

[CAN]

Schematic

EKS003SF

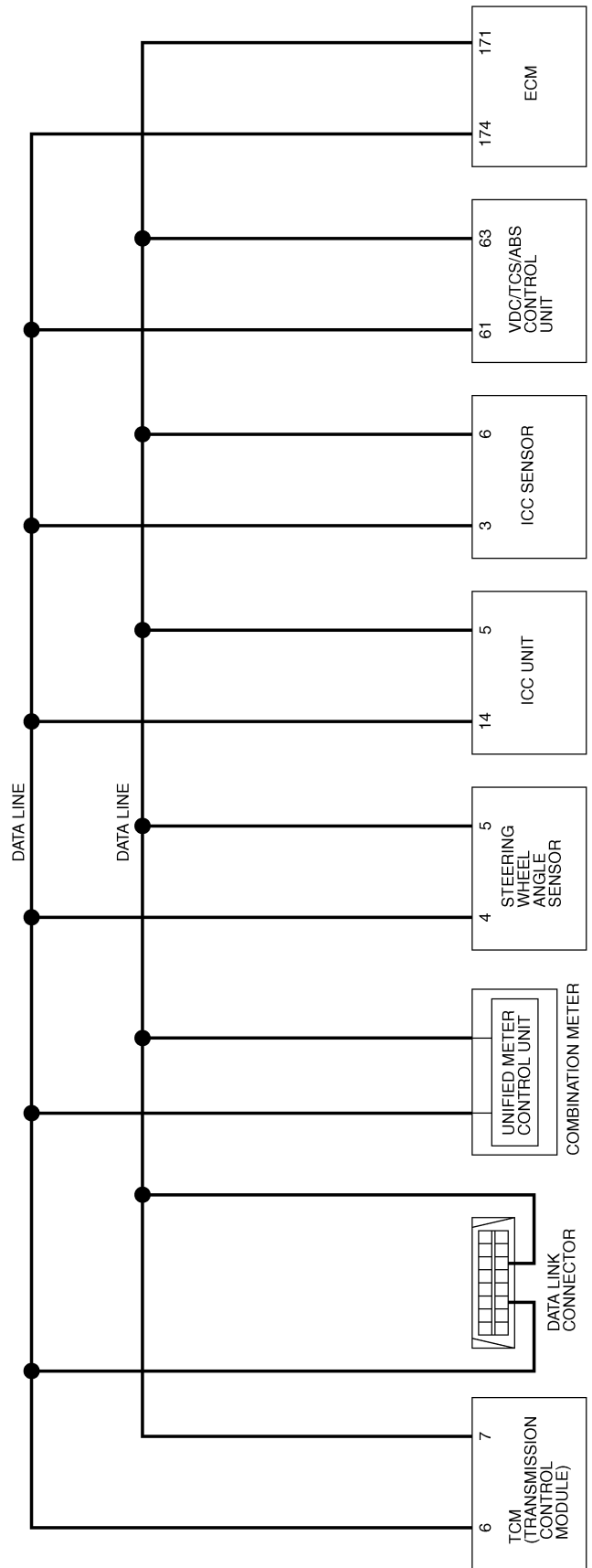

A
B
C
D
E
F
G
H
I
J
LAN
L
M

TKWM0216E

CAN SYSTEM (FOR ICC MODELS)

[CAN]

Wiring Diagram — CAN —

EKS003LZ

LAN-CAN-03

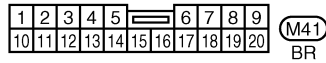
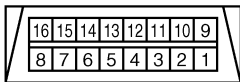
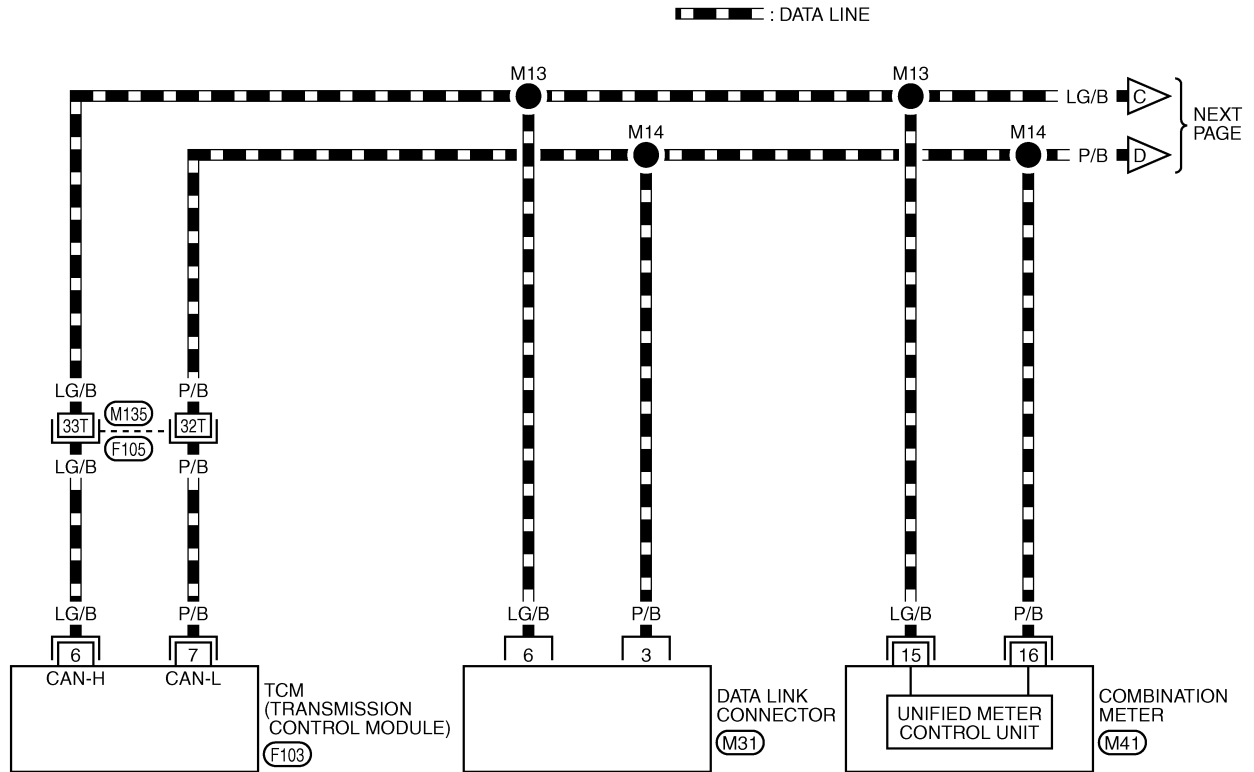

REFER TO THE FOLLOWING.

(F105) -SUPER MULTIPLE JUNCTION (SMJ)

(F103) -ELECTRICAL UNITS

TKWM0217E

CAN SYSTEM (FOR ICC MODELS)

[CAN]

LAN-CAN-04

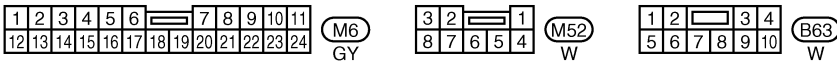
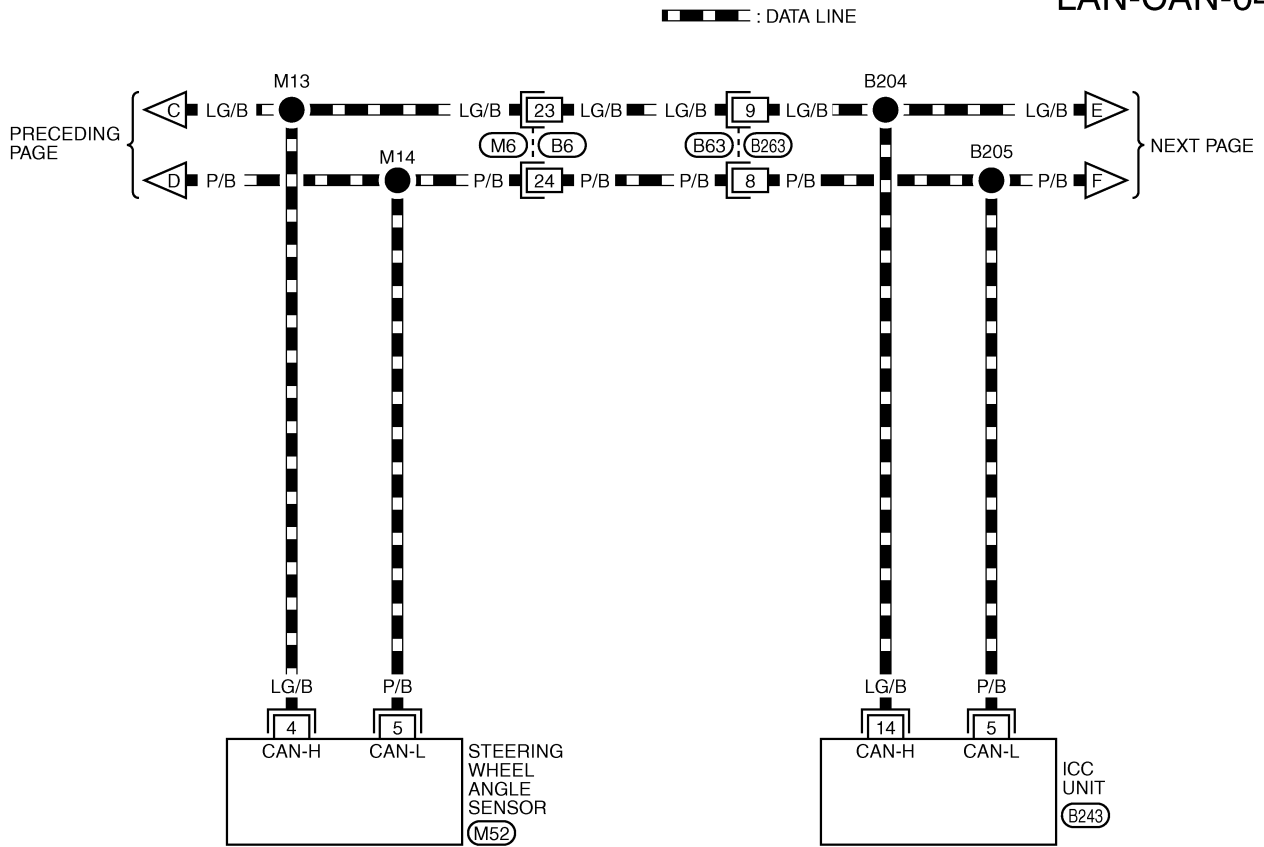

REFER TO THE FOLLOWING.
 (B243) - ELECTRICAL UNITS

A
B
C
D
E
F
G
H
I
J
LAN
L
M

LAN

▬ : DATA LINE

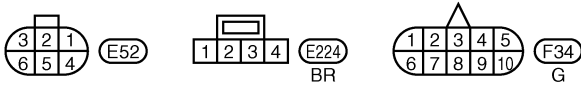
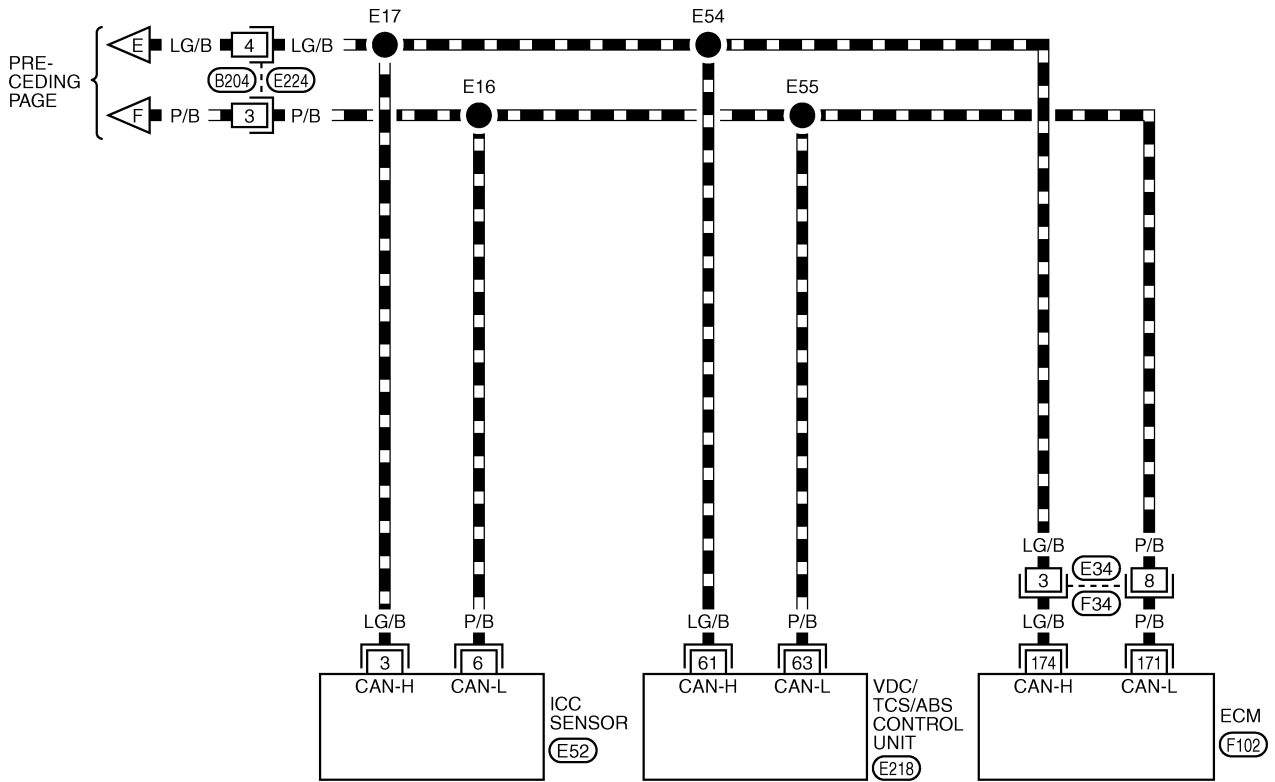

REFER TO THE FOLLOWING.
 (E218), (F102) - ELECTRICAL UNITS

TKWM0219E

CAN SYSTEM (FOR ICC MODELS)

[CAN]

CHECK SHEET

NOTE:

If "NG" is displayed on "INITIAL DIAG (Initial diagnosis)" as "CAN DIAG SUPPORT MNTR" for the diagnosed control unit, replace the control unit.

Check sheet table

SELECT SYSTEM screen	CAN DIAG SUPPORT MNTR								
	Initial diagnosis	Transmit diagnosis	Receive diagnosis						
			ECM	VDC/TCS /ABS	ICC SENSOR	ICC	STRG	METER /M&A	TCM
ENGINE	NG	UNKWN	—	UNKWN	—	—	—	UNKWN	UNKWN
VDC	NG	UNKWN	UNKWN	—	—	UNKWN	UNKWN	UNKWN	UNKWN
ICC	NG	UNKWN	UNKWN	UNKWN	UNKWN	—	—	—	UNKWN
A/T	NG	UNKWN	UNKWN	UNKWN	—	—	—	UNKWN	—

Symptoms :

Attach copy of
ENGINE
SELF-DIAG RESULTS

Attach copy of
VDC
SELF-DIAG RESULTS

Attach copy of
ICC
SELF-DIAG RESULTS

Attach copy of
A/T
SELF-DIAG RESULTS

Attach copy of
ENGINE
CAN DIAG SUPPORT
MNTR

Attach copy of
VDC
CAN DIAG SUPPORT
MNTR

Attach copy of
ICC
CAN DIAG SUPPORT
MNTR

Attach copy of
A/T
CAN DIAG SUPPORT
MNTR

CAN SYSTEM (FOR ICC MODELS)

[CAN]

CHECK SHEET RESULTS (EXAMPLE)

NOTE:

If "NG" is displayed on "INITIAL DIAG (Initial diagnosis)" as "CAN DIAG SUPPORT MNTR" for the diagnosed control unit, replace the control unit.

Case 1

Check harness between VDC/TCS/ABS control unit and ICC sensor. Refer to [LAN-59, "Circuit Check VDC/TCS/ABS Control Unit and ICC Sensor"](#).

SELECT SYSTEM screen	CAN DIAG SUPPORT MNTR								
	Initial diagnosis	Transmit diagnosis	Receive diagnosis						
			ECM	VDC/TCS /ABS	ICC SENSOR	ICC	STRG	METER /M&A	TCM
ENGINE	NG	UNKWN	—	UNKWN	—	—	—	UNKWN	UNKWN
VDC	NG	UNKWN	UNKWN	—	—	UNKWN	UNKWN	UNKWN	UNKWN
ICC	NG	UNKWN	UNKWN	UNKWN	UNKWN	—	—	—	UNKWN
A/T	NG	UNKWN	UNKWN	UNKWN	—	—	—	UNKWN	—

PKIA8664E

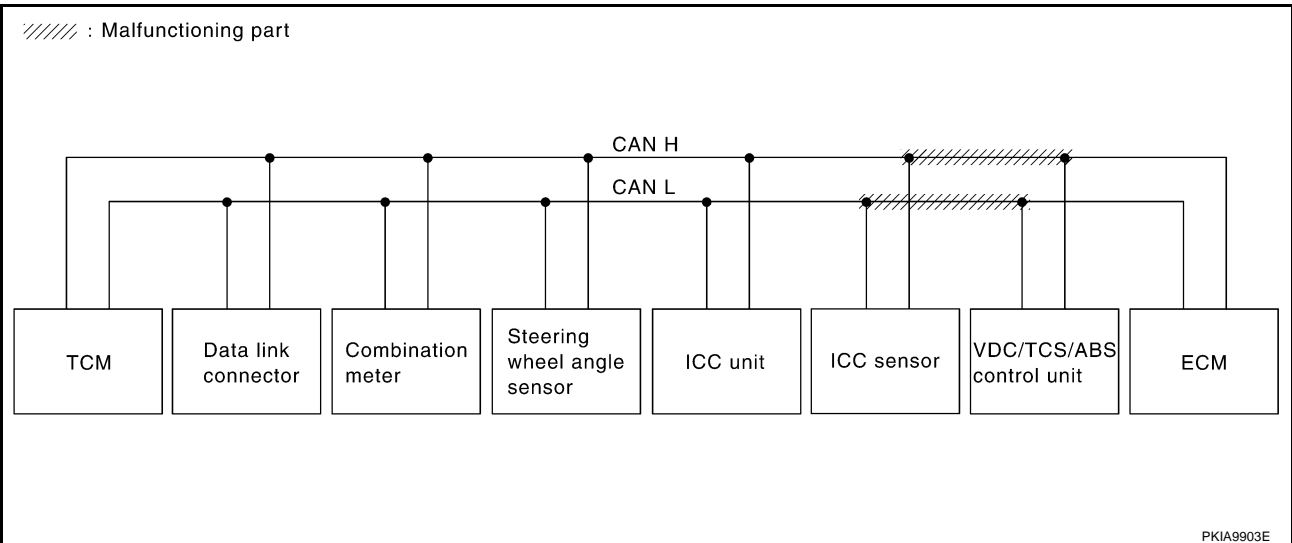

LAN

CAN SYSTEM (FOR ICC MODELS)

[CAN]

Case 2

Check harness between ICC sensor and ICC unit. Refer to [LAN-60, "Circuit Check Between ICC sensor and ICC unit"](#) .

SELECT SYSTEM screen	CAN DIAG SUPPORT MNTR								
	Initial diagnosis	Transmit diagnosis	Receive diagnosis						
			ECM	VDC/TCS /ABS	ICC SENSOR	ICC	STRG	METER /M&A	TCM
ENGINE	NG	UNKWN	—	UNKWN	—	—	—	UNKWN	UNKWN
VDC	NG	UNKWN	UNKWN	—	—	UNKWN	UNKWN	UNKWN	UNKWN
ICC	NG	UNKWN	UNKWN	UNKWN	UNKWN	—	—	—	UNKWN
A/T	NG	UNKWN	UNKWN	UNKWN	—	—	—	UNKWN	—

PKIA8665E

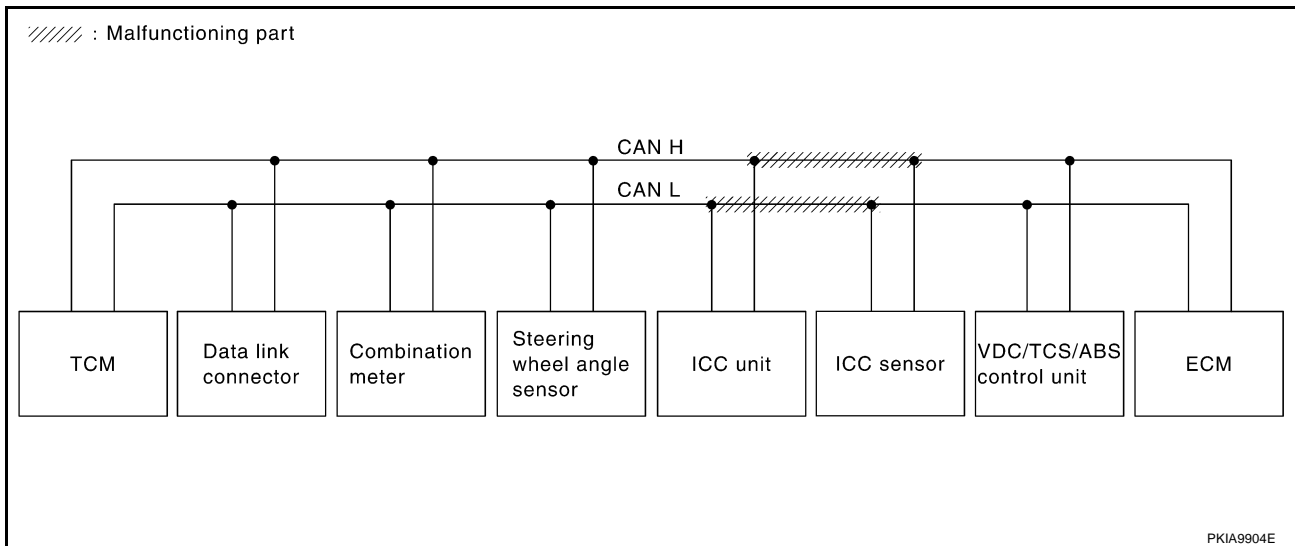

CAN SYSTEM (FOR ICC MODELS)

[CAN]

Case 3

Check harness between ICC unit and steering wheel angle sensor. Refer to [LAN-61, "Circuit Check Between ICC unit and Steering Wheel Angle Sensor"](#) .

SELECT SYSTEM screen	CAN DIAG SUPPORT MNTR								
	Initial diagnosis	Transmit diagnosis	Receive diagnosis						
			ECM	VDC/TCS /ABS	ICC SENSOR	ICC	STRG	METER /M&A	TCM
ENGINE	NG	UNKWN	—	UNKWN	—	—	—	UNKWN	UNKWN
VDC	NG	UNKWN	UNKWN	—	—	UNKWN	UNKWN	UNKWN	UNKWN
ICC	NG	UNKWN	UNKWN	UNKWN	UNKWN	—	—	—	UNKWN
A/T	NG	UNKWN	UNKWN	UNKWN	—	—	—	UNKWN	—

PKIA8666E

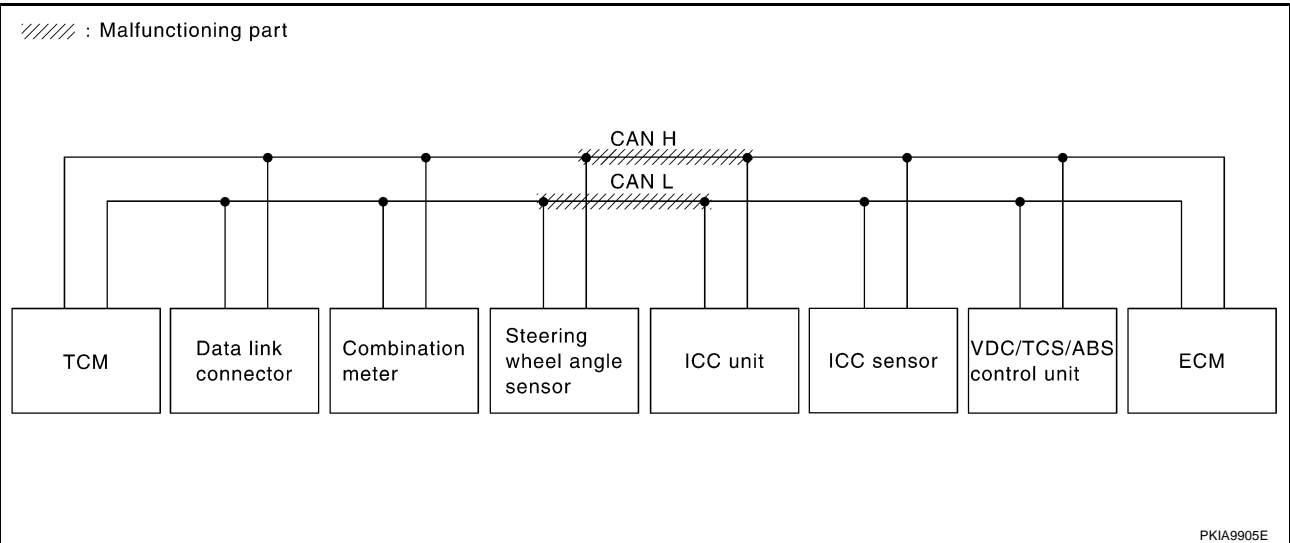

A
B
C
D
E
F
G
H
I
J
L
M

LAN

CAN SYSTEM (FOR ICC MODELS)

[CAN]

Case 4

Check harness between steering wheel angle sensor and combination meter. Refer to [LAN-62, "Circuit Check Between Steering Wheel Angle Sensor and Combination Meter"](#) .

SELECT SYSTEM screen	CAN DIAG SUPPORT MNTR								
	Initial diagnosis	Transmit diagnosis	Receive diagnosis						
			ECM	VDC/TCS /ABS	ICC SENSOR	ICC	STRG	METER /M&A	TCM
ENGINE	NG	UNKWN	—	UNKWN	—	—	—	UNKWN	UNKWN
VDC	NG	UNKWN	UNKWN	—	—	UNKWN	UNKWN	UNKWN	UNKWN
ICC	NG	UNKWN	UNKWN	UNKWN	UNKWN	—	—	—	UNKWN
A/T	NG	UNKWN	UNKWN	UNKWN	—	—	—	UNKWN	—

PKIA8667E

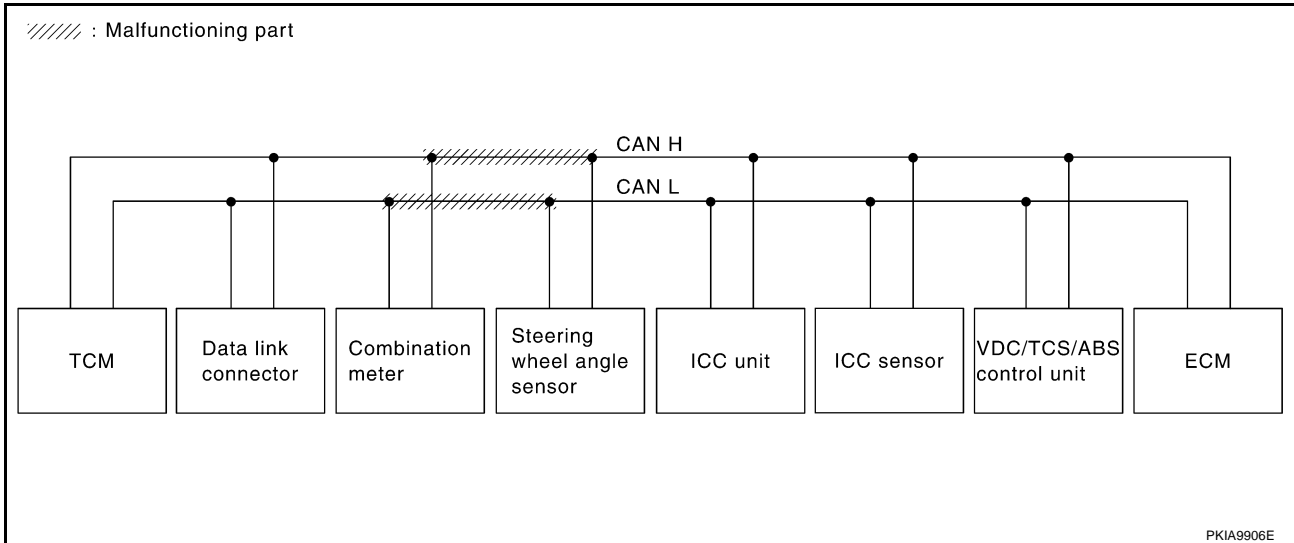

CAN SYSTEM (FOR ICC MODELS)

[CAN]

Case 5

Check ECM circuit. Refer to [LAN-62. "ECM Circuit Check"](#) .

SELECT SYSTEM screen	CAN DIAG SUPPORT MNTR								
	Initial diagnosis	Transmit diagnosis	Receive diagnosis						
			ECM	VDC/TCS /ABS	ICC SENSOR	ICC	STRG	METER /M&A	TCM
ENGINE	NG	UNKWN ✓	—	UNKWN ✓	—	—	—	UNKWN ✓	UNKWN ✓
VDC	NG	UNKWN	UNKWN ✓	—	—	UNKWN	UNKWN	UNKWN	UNKWN
ICC	NG	UNKWN	UNKWN ✓	UNKWN	UNKWN	—	—	—	UNKWN
A/T	NG	UNKWN	UNKWN ✓	UNKWN	—	—	—	UNKWN	—

PKIA8668E

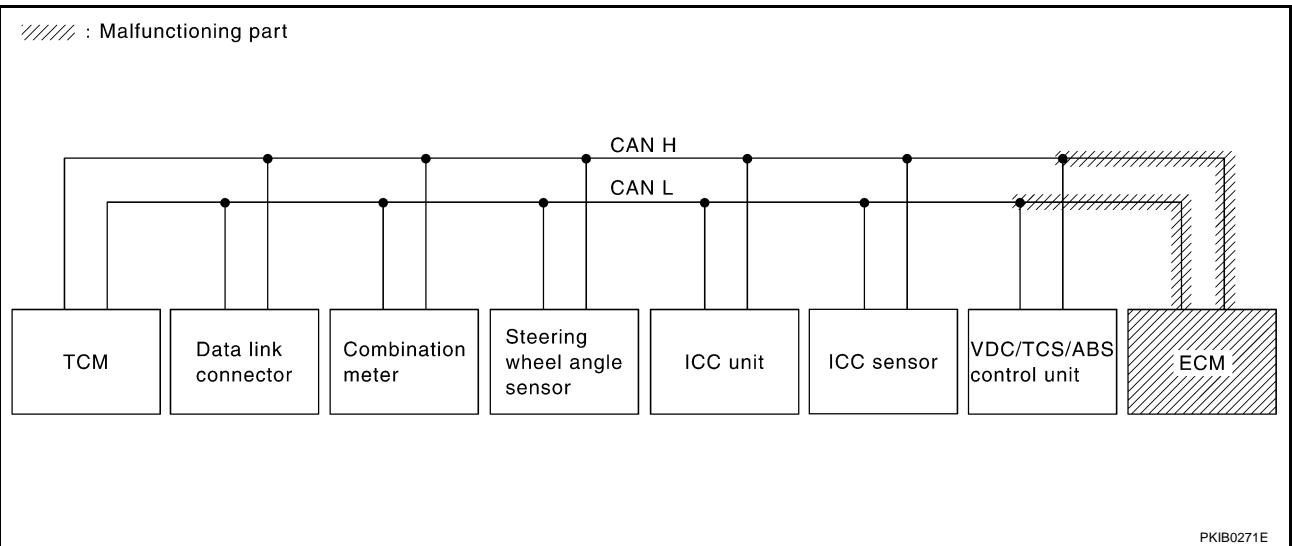

A
B
C
D
E
F
G
H
I
J
L
M

LAN

CAN SYSTEM (FOR ICC MODELS)

[CAN]

Case 6

Check VDC/TCS/ABS control unit circuit. Refer to [LAN-63, "VDC/TCS/ABS Control Unit Circuit Check"](#) .

SELECT SYSTEM screen	CAN DIAG SUPPORT MNTR								
	Initial diagnosis	Transmit diagnosis	Receive diagnosis						
			ECM	VDC/TCS /ABS	ICC SENSOR	ICC	STRG	METER /M&A	TCM
ENGINE	NG	UNKWN	—	UNKWN ✓	—	—	—	UNKWN	UNKWN
VDC	NG	UNKWN ✓	UNKWN ✓	—	—	UNKWN ✓	UNKWN ✓	UNKWN ✓	UNKWN ✓
ICC	NG	UNKWN	UNKWN	UNKWN ✓	UNKWN	—	—	—	UNKWN
A/T	NG	UNKWN	UNKWN	UNKWN ✓	—	—	—	UNKWN	—

PKIA8669E

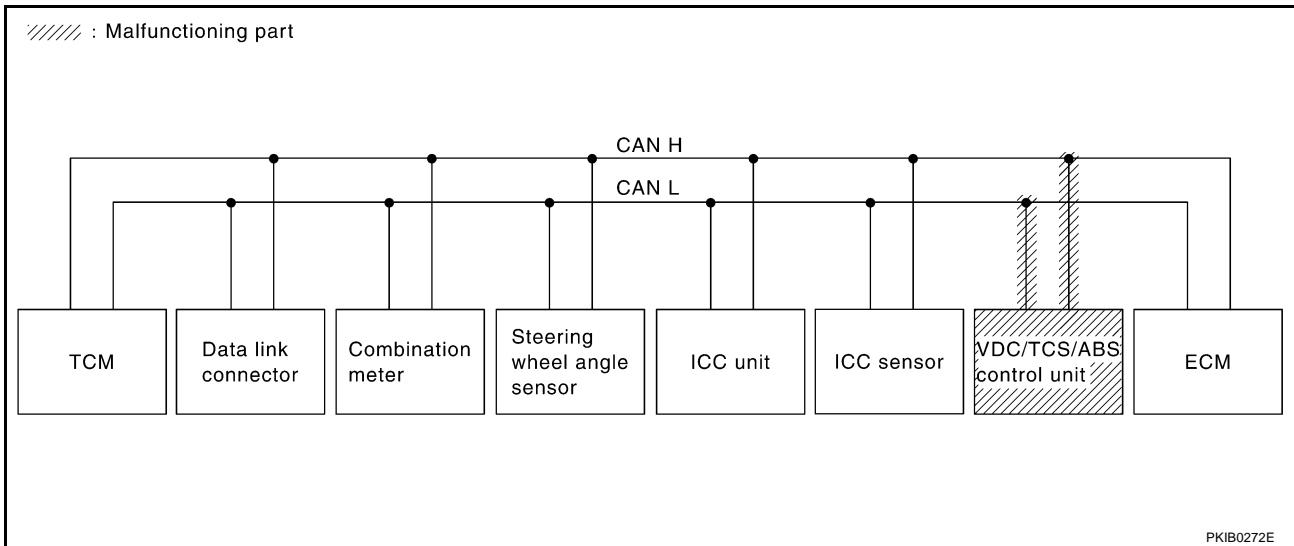

CAN SYSTEM (FOR ICC MODELS)

[CAN]

Case 7

Check ICC sensor circuit. Refer to [LAN-63. "ICC Sensor Circuit Check"](#) .

SELECT SYSTEM screen	CAN DIAG SUPPORT MNTR								
	Initial diagnosis	Transmit diagnosis	Receive diagnosis						
			ECM	VDC/TCS /ABS	ICC SENSOR	ICC	STRG	METER /M&A	TCM
ENGINE	NG	UNKWN	—	UNKWN	—	—	—	UNKWN	UNKWN
VDC	NG	UNKWN	UNKWN	—	—	UNKWN	UNKWN	UNKWN	UNKWN
ICC	NG	UNKWN	UNKWN	UNKWN	UNKWN ✓	—	—	—	UNKWN
A/T	NG	UNKWN	UNKWN	UNKWN	—	—	—	UNKWN	—

PKIA8670E

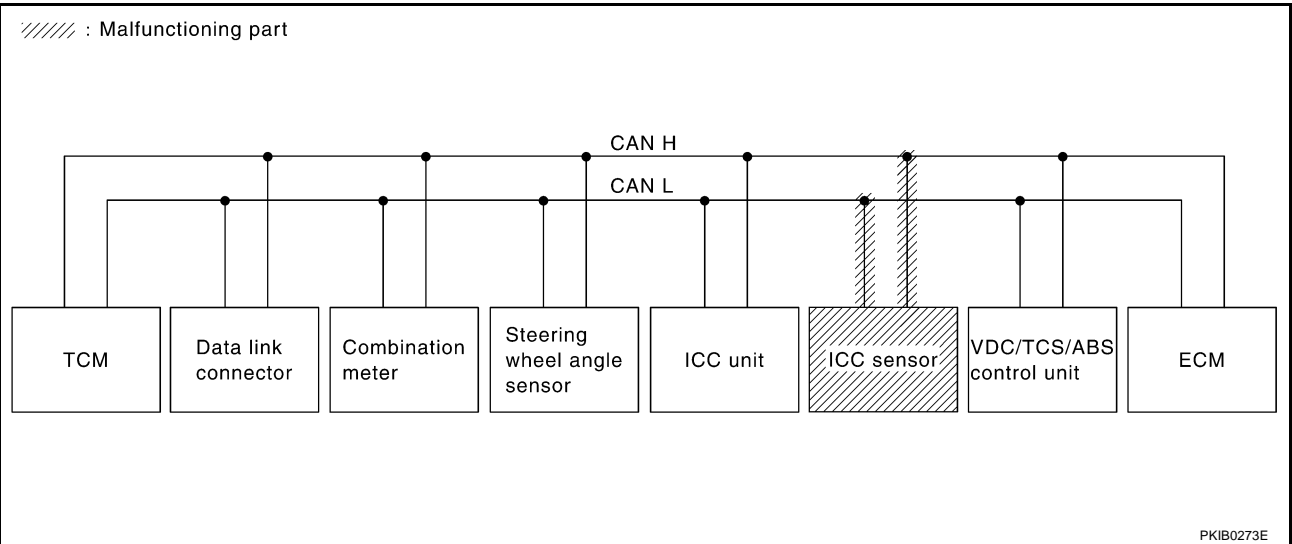

A
B
C
D
E
F
G
H
I
J
LAN
L
M

LAN

CAN SYSTEM (FOR ICC MODELS)

[CAN]

Case 8

Check ICC unit circuit. Refer to [LAN-64, "ICC Unit Circuit Check"](#) .

SELECT SYSTEM screen	CAN DIAG SUPPORT MNTR								
	Initial diagnosis	Transmit diagnosis	Receive diagnosis						
			ECM	VDC/TCS /ABS	ICC SENSOR	ICC	STRG	METER /M&A	TCM
ENGINE	NG	UNKWN	—	UNKWN	—	—	—	UNKWN	UNKWN
VDC	NG	UNKWN	UNKWN	—	—	UNKWN	UNKWN	UNKWN	UNKWN
ICC	NG	UNKWN	UNKWN	UNKWN	UNKWN	—	—	—	UNKWN
A/T	NG	UNKWN	UNKWN	UNKWN	—	—	—	UNKWN	—

PKIA8671E

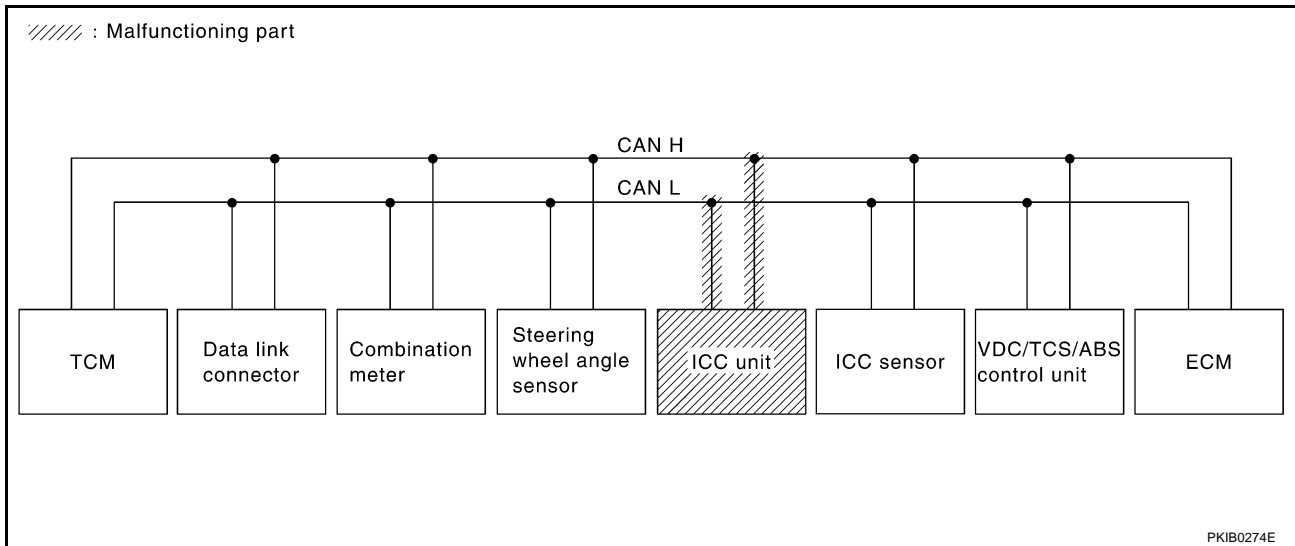

CAN SYSTEM (FOR ICC MODELS)

[CAN]

Case 9

Check steering wheel angle sensor circuit. Refer to [LAN-64, "Steering Wheel Angle Sensor Circuit Check"](#) .

SELECT SYSTEM screen	CAN DIAG SUPPORT MNTR								
	Initial diagnosis	Transmit diagnosis	Receive diagnosis						
			ECM	VDC/TCS /ABS	ICC SENSOR	ICC	STRG	METER /M&A	TCM
ENGINE	NG	UNKWN	—	UNKWN	—	—	—	UNKWN	UNKWN
VDC	NG	UNKWN	UNKWN	—	—	UNKWN	UNKWN	UNKWN	UNKWN
ICC	NG	UNKWN	UNKWN	UNKWN	UNKWN	—	—	—	UNKWN
A/T	NG	UNKWN	UNKWN	UNKWN	—	—	—	UNKWN	—

PKIA8672E

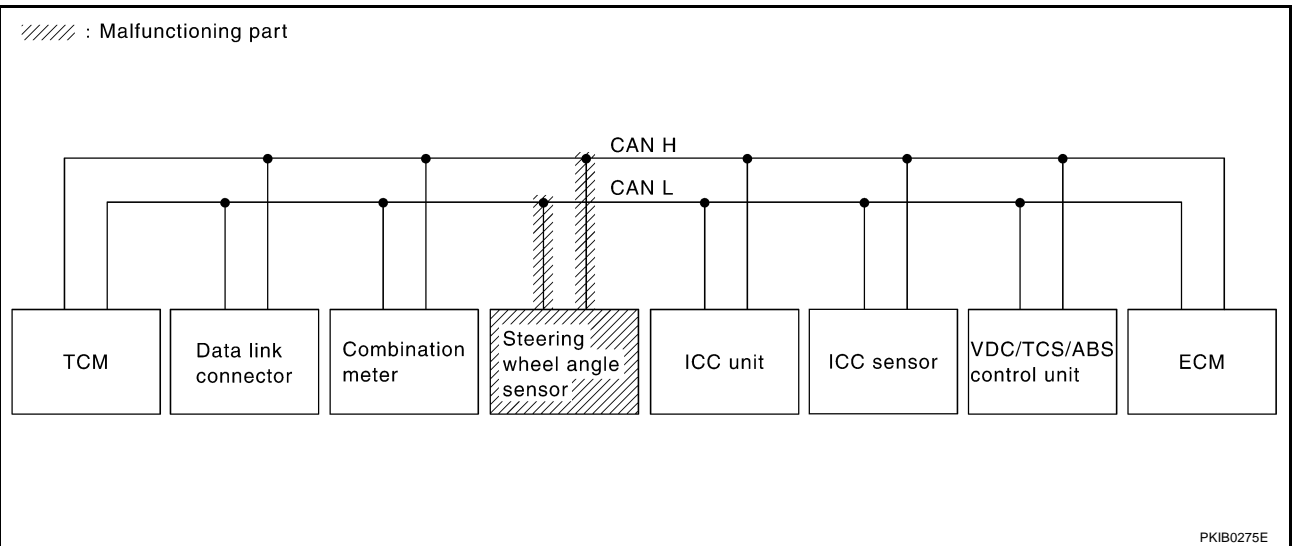

A
B
C
D
E
F
G
H
I
J
LAN
L
M

LAN

CAN SYSTEM (FOR ICC MODELS)

[CAN]

Case 10

Check combination meter circuit. Refer to [LAN-65, "Combination Meter Circuit Check"](#) .

SELECT SYSTEM screen	CAN DIAG SUPPORT MNTR								
	Initial diagnosis	Transmit diagnosis	Receive diagnosis						
			ECM	VDC/TCS /ABS	ICC SENSOR	ICC	STRG	METER /M&A	TCM
ENGINE	NG	UNKWN	—	UNKWN	—	—	—	UNKWN ✓	UNKWN
VDC	NG	UNKWN	UNKWN	—	—	UNKWN	UNKWN	UNKWN ✓	UNKWN
ICC	NG	UNKWN	UNKWN	UNKWN	UNKWN	—	—	—	UNKWN
A/T	NG	UNKWN	UNKWN	UNKWN	—	—	—	UNKWN ✓	—

PKIA8673E

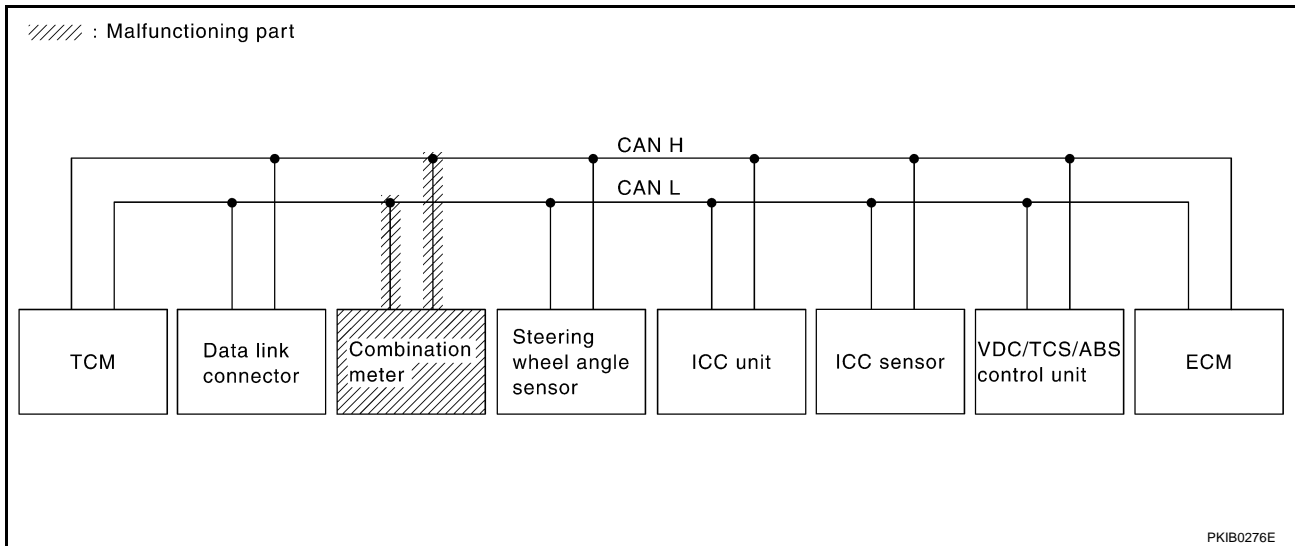

Case 11

Check TCM circuit. Refer to [LAN-65, "TCM Circuit Check"](#) .

SELECT SYSTEM screen	CAN DIAG SUPPORT MNTR									
	Initial diagnosis	Transmit diagnosis	Receive diagnosis						METER /M&A	TCM
			ECM	VDC/TCS /ABS	ICC SENSOR	ICC	STRG			
ENGINE	NG	UNKWN	—	UNKWN	—	—	—	UNKWN	UNKWN	
VDC	NG	UNKWN	UNKWN	—	—	UNKWN	UNKWN	UNKWN	UNKWN	
ICC	NG	UNKWN	UNKWN	UNKWN	UNKWN	—	—	—	UNKWN	
A/T	NG	UNKWN	UNKWN	UNKWN	—	—	—	UNKWN	—	

PKIA8674E

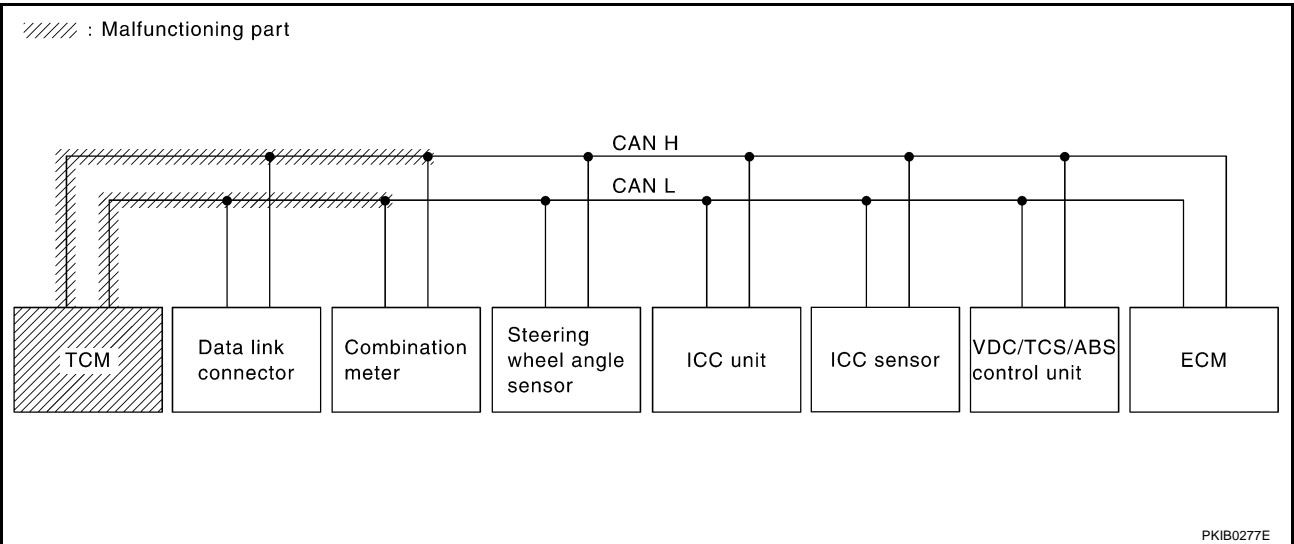

Case 12

Check CAN communication circuit. Refer to [LAN-66, "CAN Communication Circuit Check"](#) .

SELECT SYSTEM screen	CAN DIAG SUPPORT MNTR									
	Initial diagnosis	Transmit diagnosis	Receive diagnosis						METER /M&A	TCM
			ECM	VDC/TCS /ABS	ICC SENSOR	ICC	STRG			
ENGINE	NG	UNKWN	—	UNKWN	—	—	—	UNKWN	UNKWN	
VDC	NG	UNKWN	UNKWN	—	—	UNKWN	UNKWN	UNKWN	UNKWN	
ICC	NG	UNKWN	UNKWN	UNKWN	UNKWN	—	—	—	UNKWN	
A/T	NG	UNKWN	UNKWN	UNKWN	—	—	—	UNKWN	—	

PKIA8675E

Circuit Check VDC/TCS/ABS Control Unit and ICC Sensor

EKS003NB

1. CHECK CONNECTOR

1. Turn ignition switch OFF.
2. Check following terminals and connector for damage, bend and loose connection. (control unit-side, sensor-side and harness-side)
 - VDC/TCS/ABS control unit.
 - ICC sensor.

OK or NG

- OK >> GO TO 2.
 NG >> Repair terminal or connector.

A
B
C
D
E
F
G
H
I
J
L
M

LAN

2. CHECK HARNESS FOR OPEN CIRCUIT

1. Disconnect VDC/TCS/ABS control unit connector and ICC sensor connector.
2. Check continuity between VDC/TCS/ABS control unit harness connector E218 terminals 61 (LG/B), 63 (P/B) and ICC sensor harness connector E52 terminals 3 (LG/B), 6 (P/B).

61(LG/B) – 3(LG/B) : Continuity should exist.
63(P/B) – 6(P/B) : Continuity should exist.

OK or NG

- OK >> Connect all the connectors and diagnose again. Refer to [LAN-47, "Work Flow"](#) .
 NG >> Repair harness.

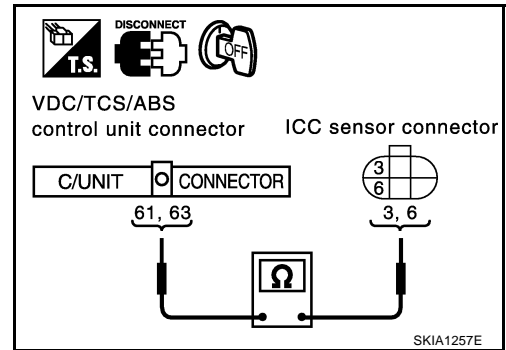

Circuit Check Between ICC sensor and ICC unit

1. CHECK CONNECTOR

1. Turn ignition switch OFF.
2. Check following terminals and connector for damage, bend and loose connection.(sensor-side, unit-side and harness-side)
 - ICC sensor.
 - ICC unit.
 - Between ICC sensor and ICC unit.

OK or NG

- OK >> GO TO 2.
 NG >> Repair terminal or connector.

2. CHECK HARNESS FOR OPEN CIRCUIT

1. Disconnect ICC sensor connector and harness connector E224.
2. Check continuity between ICC sensor harness connector E52 terminals 3(LG/B), 6 (P/B) and harness connector E224 terminals 4 (LG/B), 3 (P/B).

3 (LG/B) – 4 (LG/B) : Continuity should exist.
6 (P/B) – 3 (P/B) : Continuity should exist.

OK or NG

- OK >> GO TO 3.
 NG >> Repair harness.

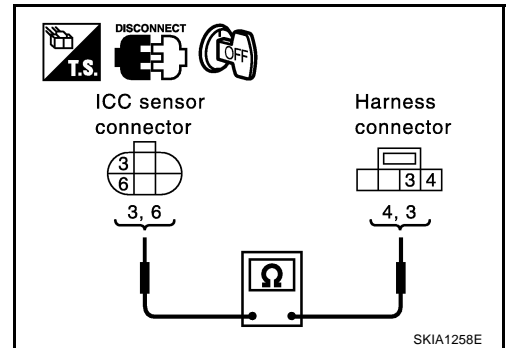

3. CHECK HARNESS FOR OPEN CIRCUIT

1. Disconnect ICC unit connector.
2. Check continuity between harness connector B204 terminals 4 (LG/B), 3 (P/B) and ICC unit connector B243 terminals 14 (LG/B), 5 (P/B).

4 (LG/B) – 14 (LG/B) : Continuity should exist.
3 (P/B) – 5 (P/B) : Continuity should exist.

OK or NG

- OK >> Connect all the connectors and diagnose again. Refer to [LAN-47, "Work Flow"](#) .
 NG >> Repair harness.

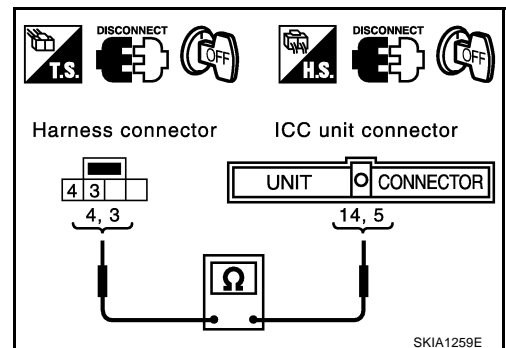

Circuit Check Between ICC unit and Steering Wheel Angle Sensor

1. CHECK CONNECTOR

1. Turn ignition switch OFF.
2. Check following terminals and connector for damage, bend and loose connection.(unit-side, sensor-side and harness-side)
 - ICC unit.
 - Steering wheel angle sensor.
 - Between ICC unit and steering wheel angle sensor.

OK or NG

- OK >> GO TO 2.
 NG >> Repair terminal or connector.

2. CHECK HARNESS FOR OPEN CIRCUIT

1. Disconnect ICC unit connector and harness connector B263.
2. Check continuity between ICC unit harness connector B243 terminals 14 (LG/B), 5 (P/B) and harness connector B263 terminals 9 (LG/B), 8 (P/B).

- 14 (LG/B) – 9 (LG/B) : Continuity should exist.**
5 (P/B) – 8 (P/B) : Continuity should exist.

OK or NG

- OK >> GO TO 3.
 NG >> Repair harness.

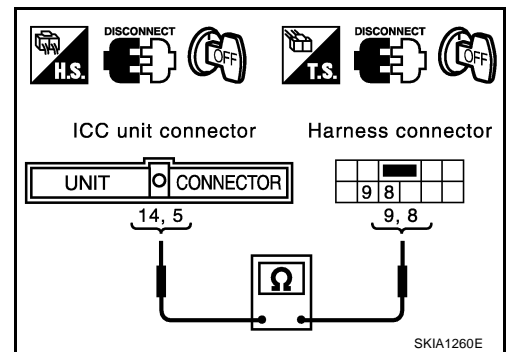

3. CHECK HARNESS FOR OPEN CIRCUIT

1. Disconnect harness connector B6.
2. Check continuity between harness connector B63 terminals 9(LG/B), 8 (P/B) and harness connector B6 terminals 23(LG/B), 24 (P/B).

- 9 (LG/B) – 23 (LG/B) : Continuity should exist.**
8 (P/B) – 24 (P/B) : Continuity should exist.

OK or NG

- OK >> GO TO 4.
 NG >> Repair harness.

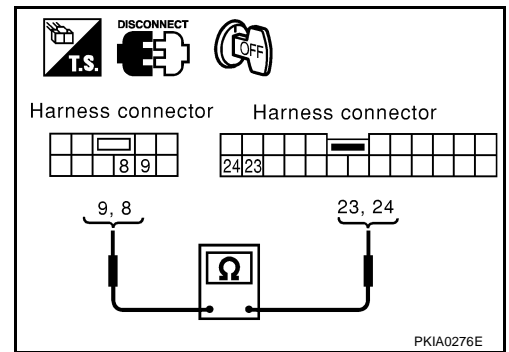

4. CHECK HARNESS FOR OPEN CIRCUIT

1. Disconnect steering wheel angle sensor connector.
2. Check continuity between harness connector M6 terminals 23(LG/B), 24 (P/B) and steering wheel angle sensor harness connector M52 terminals 4 (LG/B), 5 (P/B).

- 23 (LG/B) – 4 (LG/B) : Continuity should exist.**
24 (P/B) – 5 (P/B) : Continuity should exist.

OK or NG

- OK >> Connect all the connectors and diagnose again. Refer to [LAN-47, "Work Flow"](#) .
 NG >> Repair harness.

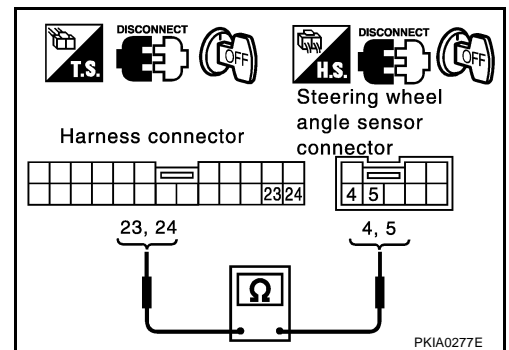

Circuit Check Between Steering Wheel Angle Sensor and Combination Meter

EKS003M2

1. CHECK CONNECTOR

1. Turn ignition switch OFF.
2. Check following terminals and connector for damage, bend and loose connection. (sensor-side, meter-side and harness-side)
 - Steering wheel angle sensor.
 - Combination meter.

OK or NG

- OK >> GO TO 2.
 NG >> Repair terminal or connector.

2. CHECK HARNESS FOR OPEN CIRCUIT

1. Disconnect steering wheel angle sensor connector and combination meter connector.
2. Check continuity between steering wheel angle sensor harness connector M52 terminals 4 (LG/B), 5 (P/B) and combination meter harness connector M41 terminals 15(LG/B), 16 (P/B).

- 4 (LG/B) – 15 (LG/B) : Continuity should exist.**
5 (P/B) – 16 (P/B) : Continuity should exist.

OK or NG

- OK >> Connect all the connectors and diagnose again. Refer to [LAN-47, "Work Flow"](#) .
 NG >> Repair harness.

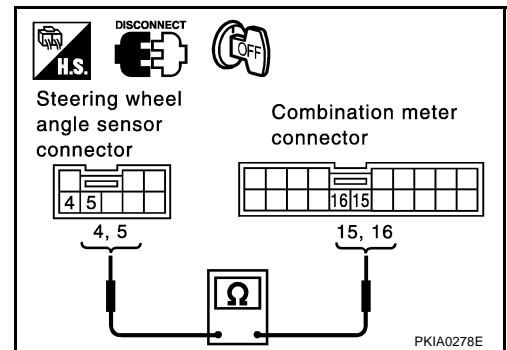

EKS003M3

ECM Circuit Check

1. CHECK CONNECTOR

1. Turn ignition switch OFF.
2. Check following terminals and connector for damage, bend and loose connection. (control module-side and harness-side)
 - ECM.
 - Harness connector F34.
 - Harness connector E34.

OK or NG

- OK >> GO TO 2.
 NG >> Repair terminal or connector.

2. CHECK HARNESS FOR OPEN CIRCUIT

1. Disconnect ECM connector.
2. Check resistance between ECM harness connector F102 terminals 174 (LG/B) and 171 (P/B).

- 174 (LG/B) – 171 (P/B) : Approx. 108 – 132Ω**

OK or NG

- OK >> Replace ECM.
 NG >> Repair harness between splice points E54, E55 and ECM.

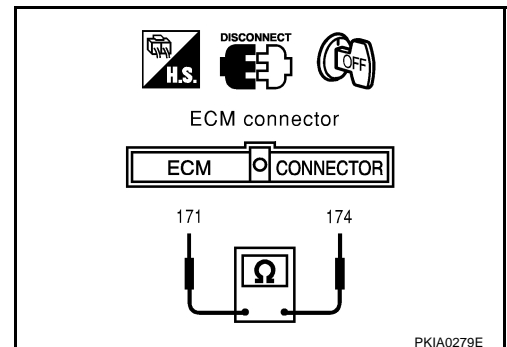

VDC/TCS/ABS Control Unit Circuit Check

1. CHECK CONNECTOR

1. Turn ignition switch OFF.
2. Check the terminals and connector of VDC/TCS/ABS control unit for damage, bend and loose connection. (control unit-side and harness-side)

OK or NG

- OK >> GO TO 2.
 NG >> Repair terminal or connector.

2. CHECK HARNESS FOR OPEN CIRCUIT

1. Disconnect VDC/TCS/ABS control unit connector.
2. Check resistance between VDC/TCS/ABS control unit harness connector E218 terminals 61 (LG/B) and 63 (P/B).

61 (LG/B) – 63 (P/B) : Approx. 54 – 66Ω

OK or NG

- OK >> Replace VDC/TCS/ABS control unit.
 NG >> Repair harness between splice points E54, E55 and VDC/TCS/ABS control unit.

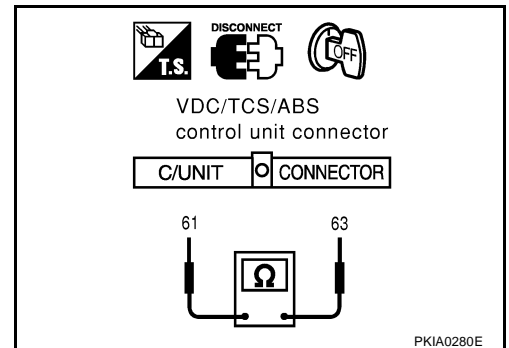

ICC Sensor Circuit Check

1. CHECK CONNECTOR

1. Turn ignition switch OFF.
2. Check the terminals and connector of ICC sensor for damage, bend and loose connection. (sensor-side and harness-side)

OK or NG

- OK >> GO TO 2.
 NG >> Repair terminal or connector.

2. CHECK HARNESS FOR OPEN CIRCUIT

1. Disconnect ICC sensor connector.
2. Check resistance between ICC sensor harness connector E52 terminals 3 (LG/B) and 6 (P/B).

3 (LG/B) – 6 (P/B) : Approx. 54 – 66Ω

OK or NG

- OK >> Replace ICC sensor.
 NG >> Repair harness between splice points E17, E16 and ICC sensor.

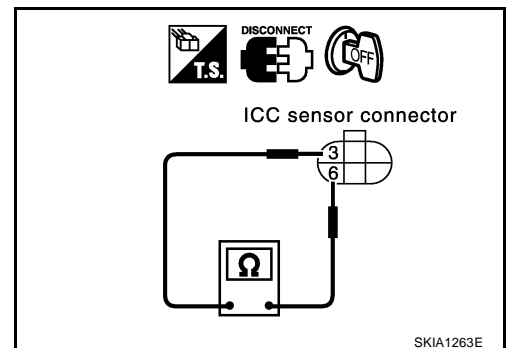

ICC Unit Circuit Check

1. CHECK CONNECTOR

1. Turn ignition switch OFF.
2. Check the terminals and connector of ICC unit for damage, bend and loose connection. (unit-side and harness-side)

OK or NG

- OK >> GO TO 2.
 NG >> Repair terminal or connector.

2. CHECK HARNESS FOR OPEN CIRCUIT

1. Disconnect ICC unit connector.
2. Check resistance between ICC unit harness connector B243 terminals 14 (LG/B) and 5 (P/B).

14 (LG/B) – 5 (P/B) : Approx. 54 – 66Ω

OK or NG

- OK >> Replace ICC unit.
 NG >> Repair harness between splice points B204, B205 and ICC unit.

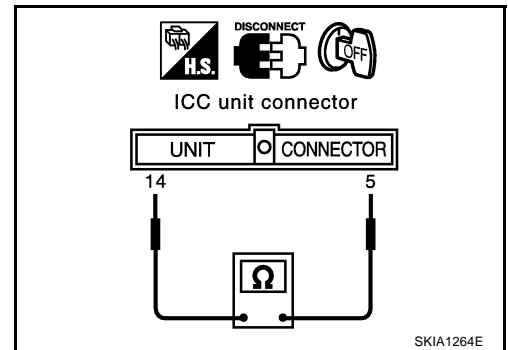

Steering Wheel Angle Sensor Circuit Check

1. CHECK CONNECTOR

1. Turn ignition switch OFF.
2. Check the terminals and connector of steering wheel angle sensor for damage, bend and loose connection. (sensor-side and harness-side)

OK or NG

- OK >> GO TO 2.
 NG >> Repair terminal or connector.

2. CHECK HARNESS FOR OPEN CIRCUIT

1. Disconnect steering wheel angle sensor connector.
2. Check resistance between steering wheel angle sensor harness connector M52 terminals 4 (LG/B) and 5 (P/B).

4 (LG/B) – 5 (P/B) : Approx. 54 – 66Ω

OK or NG

- OK >> Replace steering wheel angle sensor.
 NG >> Repair harness between splice points M13, M14 and steering wheel angle sensor.

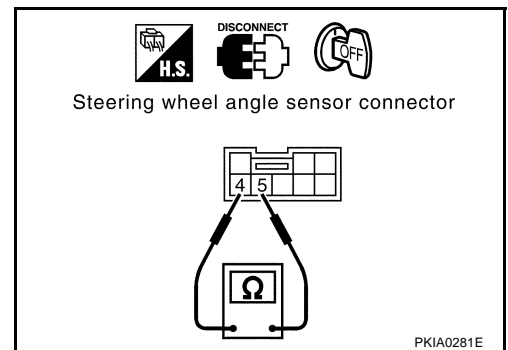

Combination Meter Circuit Check

1. CHECK CONNECTOR

1. Turn ignition switch OFF.
2. Check terminals and connector of combination meter for damage, bend and loose connection.(meter-side and harness-side)

OK or NG

- OK >> GO TO 2.
 NG >> Repair terminal or connector.

2. CHECK HARNESS FOR OPEN CIRCUIT

1. Disconnect combination meter connector.
2. Check resistance between combination meter harness connector M41 terminals 15 (LG/B) and 16 (P/B).

15 (LG/B) – 16 (P/B) : Approx. 54 – 66Ω

OK or NG

- OK >> Replace combination meter.
 NG >> Repair harness between splice points M13, M14 and combination meter.

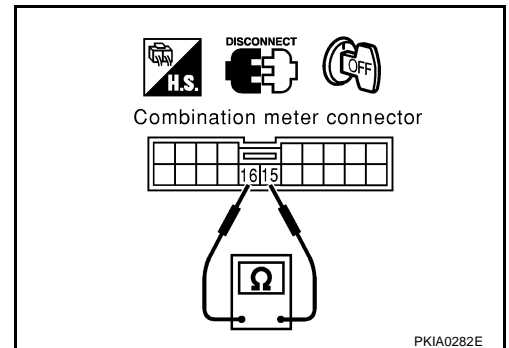

TCM Circuit Check

1. CHECK CONNECTOR

1. Turn ignition switch OFF.
2. Check following terminals and connector for damage, bend and loose connection.(control module-side and harness-side)

- TCM.
- Harness connector F105.
- Harness connector M135.

OK or NG

- OK >> GO TO 2.
 NG >> Repair terminal or connector.

2. CHECK HARNESS FOR OPEN CIRCUIT

1. Disconnect TCM connector.
2. Check resistance between TCM harness connector F103 terminals 6 (LG/B) and 7(P/B).

6 (LG/B) – 7 (P/B) : Approx. 108 – 132Ω

OK or NG

- OK >> Replace TCM.
 NG >> Repair harness between splice points M13, M14 and TCM.

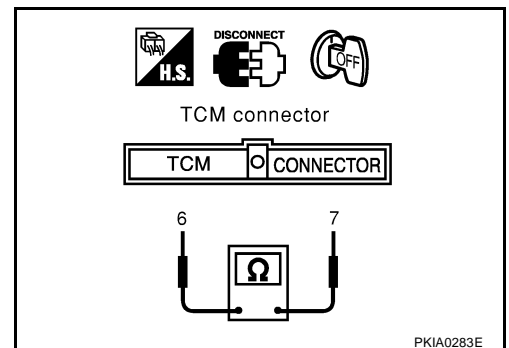

A
B
C
D
E
F
G
H
I
J
L
M

LAN

CAN Communication Circuit Check

1. CHECK CONNECTOR

1. Turn ignition switch OFF.
2. Check following terminals and connector for damage, bend and loose connection.(control module-side, control unit-side, unit-side, meter-side, sensor-side and harness-side)
 - TCM.
 - Combination meter.
 - Steering wheel angle sensor.
 - ICC unit.
 - ICC sensor.
 - VDC/TCS/ABS control unit.
 - ECM.
 - Between TCM and ECM.

OK or NG

- OK >> GO TO 2.
 NG >> Repair terminal or connector.

2. CHECK HARNESS FOR SHORT CIRCUIT

1. Disconnect TCM connector and harness connector F105.
2. Check continuity between TCM harness connector F103 terminals 6 (LG/B) and 7(P/B).

6 (LG/B) – 7 (P/B) : Continuity should not exist.

OK or NG

- OK >> GO TO 3.
 NG >> Repair harness between TCM and harness connector F105.

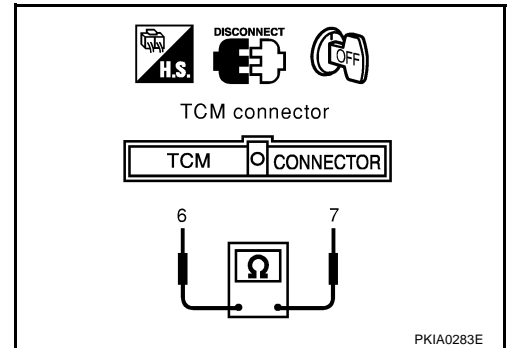

3. CHECK HARNESS FOR SHORT CIRCUIT

Check continuity between TCM harness connector F103 terminals 6 (LG/B), 7 (P/B) and ground.

6 (LG/B) – ground : Continuity should not exist.

7 (P/B) – ground : Continuity should not exist.

OK or NG

- OK >> GO TO 4.
 NG >> Repair harness between TCM and harness connector F105.

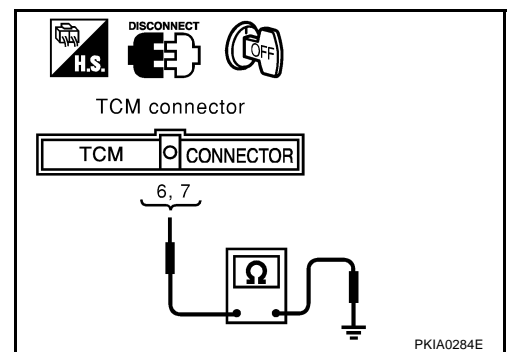

4. CHECK HARNESS FOR SHORT CIRCUIT

1. Disconnect combination meter connector, steering wheel angle sensor connector and harness connector M6.
2. Check continuity between Data Link Connector M31 terminals 6 (LG/B) and 3 (P/B).

6 (LG/B) – 3 (P/B) : Continuity should not exist.

OK or NG

OK >> GO TO 5.

NG >> ● Repair harness between harness connector M6 and harness connector M135.

- Repair harness between splice points M13, M14 and Data Link Connector.
- Repair harness between splice points M13, M14 and combination meter.
- Repair harness between splice points M13, M14 and steering wheel angle sensor.

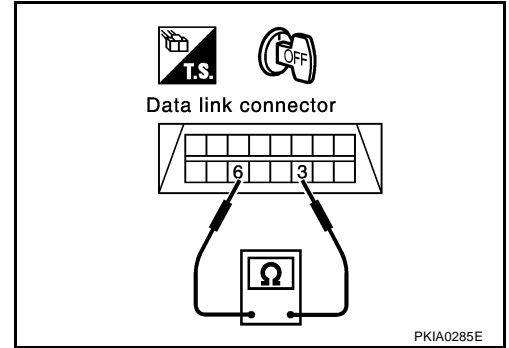

5. CHECK HARNESS FOR SHORT CIRCUIT

Check continuity between Data Link Connector M31 terminals 6 (LG/B), 3 (P/B) and ground.

6 (LG/B) – ground : Continuity should not exist.

3 (P/B) – ground : Continuity should not exist.

OK or NG

OK >> GO TO 6.

NG >> ● Repair harness between harness connector M6 and harness connector M135.

- Repair harness between splice points M13, M14 and Data Link Connector.
- Repair harness between splice points M13, M14 and combination meter.
- Repair harness between splice points M13, M14 and steering wheel angle sensor.

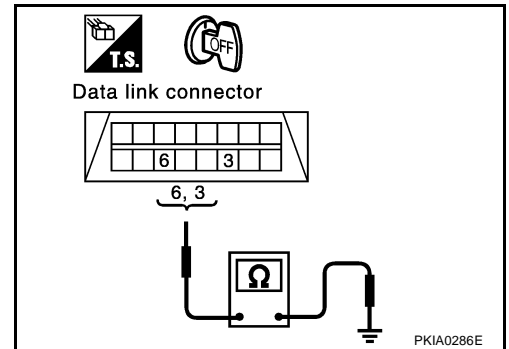

6. CHECK HARNESS FOR SHORT CIRCUIT

1. Disconnect harness connector B63.
2. Check continuity between harness connector B6 terminals 23 (LG/B) and 24 (P/B).

23 (LG/B) – 24 (P/B) : Continuity should not exist.

OK or NG

OK >> GO TO 7.

NG >> Repair harness between harness connector B6 and harness connector B63.

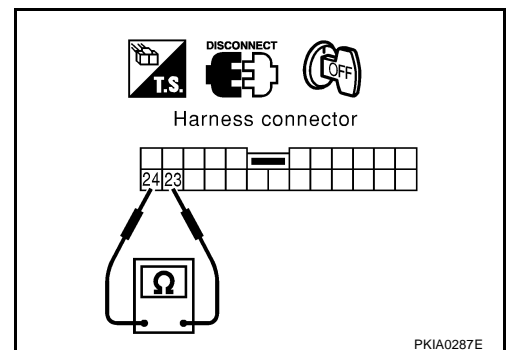

7. CHECK HARNESS FOR SHORT CIRCUIT

Check continuity between harness connector B6 terminals 23 (LG/B), 24 (P/B) and ground.

23 (LG/B) – ground : Continuity should not exist.

24 (P/B) – ground : Continuity should not exist.

OK or NG

OK >> GO TO 8.

NG >> Repair harness between harness connector B6 and harness connector B63.

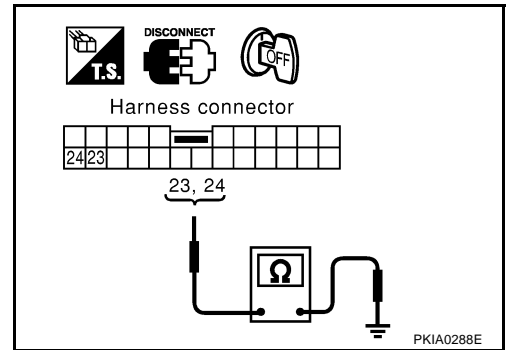

8. CHECK HARNESS FOR SHORT CIRCUIT

1. Disconnect harness connector B204 and ICC unit connector.
2. Check continuity between harness connector B263 terminals 9 (LG/B) and 8 (P/B).

9 (LG/B) – 8 (P/B) : Continuity should not exist.

OK or NG

OK >> GO TO 9.

NG >> ● Repair harness between harness connector B263 and harness connector B204.

- Repair harness between splice points B204, B205 and ICC unit.

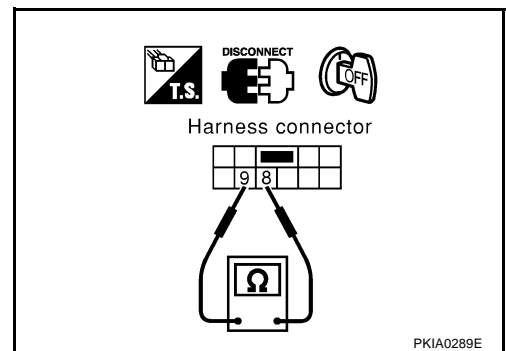

9. CHECK HARNESS FOR SHORT CIRCUIT

Check continuity between harness connector B263 terminals 9 (LG/B), 8 (P/B) and ground.

9 (LG/B) – ground : Continuity should not exist.

8 (P/B) – ground : Continuity should not exist.

OK or NG

OK >> GO TO 10.

NG >> ● Repair harness between harness connector B263 and harness connector B204.

- Repair harness between splice points B204, B205 and ICC unit.

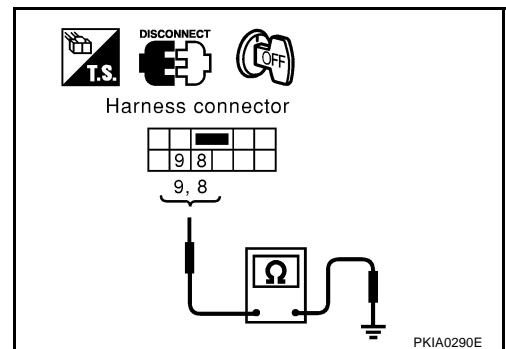

10. CHECK HARNESS FOR SHORT CIRCUIT

1. Disconnect ICC sensor connector, VDC/TCS/ABS control unit connector and harness connector E34.
2. Check continuity between VDC/TCS/ABS control unit harness connector E218 terminals 61 (LG/B) and 63 (P/B).

61 (LG/B) – 63 (P/B) : Continuity should not exist.

OK or NG

- OK >> GO TO 11.
- NG >> ● Repair harness between harness connector E34 and harness connector E224.
- Repair harness between splice points E54, E55 and VDC/TCS/ABS control unit.
 - Repair harness between splice points E17, E16 and ICC sensor.

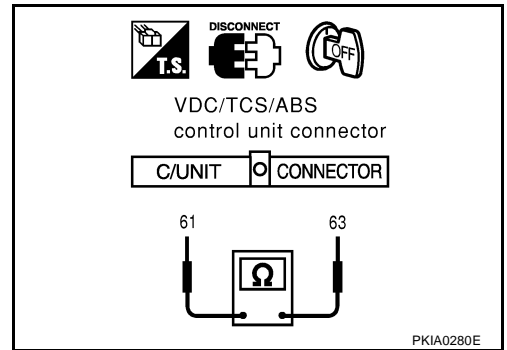

11. CHECK HARNESS FOR SHORT CIRCUIT

Check continuity between VDC/TCS/ABS control unit harness connector E218 terminals 61 (LG/B), 63 (P/B) and ground.

61 (LG/B) – ground : Continuity should not exist.

63 (P/B) – ground : Continuity should not exist.

OK or NG

- OK >> GO TO 12.
- NG >> ● Repair harness between harness connector E34 and harness connector E224.
- Repair harness between splice points E54, E55 and VDC/TCS/ABS control unit.
 - Repair harness between splice points E17, E16 and ICC sensor.

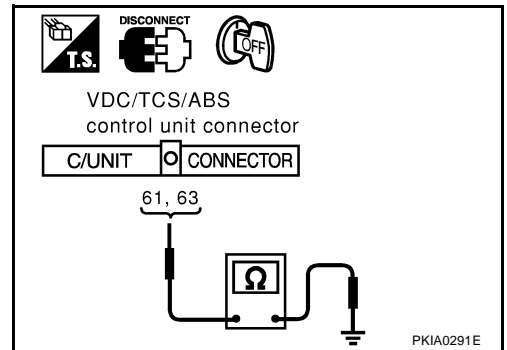

12. CHECK HARNESS FOR SHORT CIRCUIT

1. Disconnect ECM connector.
2. Check continuity between ECM harness connector F102 terminals 174 (LG/B) and 171(P/B).

174(LG/B) – 171(P/B) : Continuity should not exist.

OK or NG

- OK >> GO TO 13.
- NG >> Repair harness between ECM and harness connector F34.

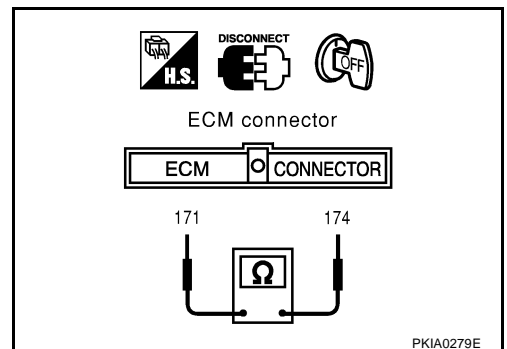

A
B
C
D
E
F
G
H
I
J
LAN
L
M

13. CHECK HARNESS FOR SHORT CIRCUIT

Check continuity between ECM harness connector F102 terminals 174 (LG/B), 171 (P/B) and ground.

174(LG/B) – ground : Continuity should not exist.

171(P/B) – ground : Continuity should not exist.

OK or NG

OK >> GO TO 14.

NG >> Repair harness between ECM and harness connector F34.

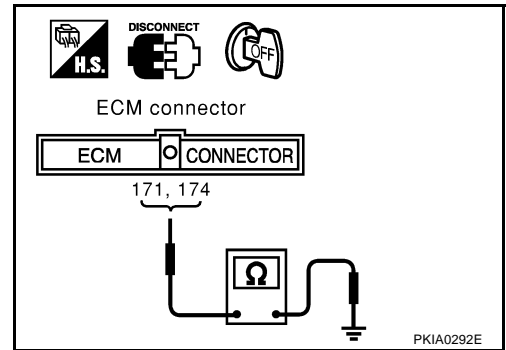

14. ECM/TCM INTERNAL CIRCUIT INSPECTION

Check components inspection. Refer to [LAN-70, "ECM/TCM INTERNAL CIRCUIT INSPECTION"](#)

OK or NG

OK >> Connect all the connectors and diagnose again. Refer to [LAN-47, "Work Flow"](#) .

NG >> Replace ECM and/or TCM.

Component Inspection ECM/TCM INTERNAL CIRCUIT INSPECTION

EKS003M9

- Remove ECM and TCM from vehicle.
- Check resistance between ECM terminals 174 and 171.
- Check resistance between TCM terminals 6 and 7.

Unit	Terminal	Resistance value (Ω)
ECM	174 – 171	Approx. 108 - 132
TCM	6 – 7	

