

DI

SECTION

DRIVER INFORMATION SYSTEM

A
B
C
D
E
F
G
H
I
J
L
M

CONTENTS

PRECAUTIONS	5	Power Supply and Ground Circuit Check	21
Precautions for Supplemental Restraint System (SRS) "AIR BAG" and "SEAT BELT PRE-TENSIONER"	5	Fluorescent Lamp Check	22
Wiring Diagrams and Trouble Diagnosis	5	Inspection/Engine Speed Signal	22
PREPARATION	6	Inspection/Water Temperature Gauge	23
Commercial Service Tools	6	Inspection/Vehicle Speed Signal	23
COMBINATION METERS	7	Inspection/Fuel Level Sensor Unit	23
System Description	7	FUEL LEVEL SENSOR UNIT	23
UNIFIED CONTROL METER	7	LOW-FUEL WARNING LAMP	23
HOW TO CHANGE THE DISPLAY FOR ODO/TRIP METER	7	Fuel Gauge Pointer Fluctuates, Indicator Wrong Value, Or Varies	25
POWER SUPPLY AND GROUND CIRCUIT	7	Fuel Gauge Does Not Move to Full-Position	25
WATER TEMPERATURE GAUGE	8	Fuel Gauge Does Not Work	25
TACHOMETER	8	Low-Fuel Warning Lamp Illuminate or Not Illuminate	26
FUEL GAUGE	8	ICC System Display Does Not Illuminate	26
SPEEDOMETER	8	Electrical Components Inspection	26
CAN Communication	9	CHECK FUEL LEVEL SENSOR UNIT	26
SYSTEM DESCRIPTION	9	Removal and Installation for Combination Meter	27
FOR VDC MODELS	9	REMOVAL	27
FOR ICC MODELS	10	INSTALLATION	27
Component Parts and Harness Connector Location	11	Disassembly and Assembly for Combination Meter	28
Combination Meter/Without ICC System	12	COMPASS	29
CHECK	12	System Description	29
Combination Meter/With ICC System	13	DIRECTION DISPLAY	29
CHECK	13	Wiring Diagram – COMPAS –	31
Schematic	14	Removal and Installation of Compass	32
Wiring Diagram — METER —	15	WARNING LAMPS	33
Terminals and Reference Value for Combination Meter	17	System Description	33
Meter/Gauges Operation, Odo/Trip Meter, A/T Indicator and ICC System Display	18	OUTLINE	33
SELF-DIAGNOSIS FUNCTION	18	AIR BAG WARNING LAMP	33
HOW TO ALTERNATE DIAGNOSIS MODE	18	DOOR WARNING LAMP	33
Work Flow	19	ACTIVE DAMPER INDICATOR LAMP (SPORT)	33
Trouble Diagnoses	20	LOW OIL PRESSURE WARNING LAMP	33
SYMPTOM CHART 1 (MALFUNCTION INDICATED DIAGNOSIS MODE)	20	CHARGE WARNING LAMP	33
SYMPTOM CHART 2 (NO MALFUNCTION INDICATED IN DIAGNOSIS MODE)	20	LOW WASHER LEVEL WARNING LAMP	34
		A/T OIL TEMPERATURE WARNING LAMP	34
		LOW-FUEL LEVEL WARNING LAMP	34
		ABS WARNING LAMP	34
		VDC OFF INDICATOR LAMP	34
		SLIP INDICATOR LAMP	34

SEAT BELT WARNING LAMP	34	Lighting Switch Input Signal Inspection	73
BRAKE WARNING LAMP	35	Seat Belt Buckle Switch Inspection	74
MALFUNCTION INDICATOR LAMP	35	Removal and Installation of Warning Chime	75
LOW TIRE PRESSURE WARNING LAMP	35	REMOVAL	75
ASCD WARNING LAMP	35	INSTALLATION	75
ICC SYSTEM WARNING LAMP	35	VEHICLE INFORMATION AND INTEGRATED	
WARNING MESSAGE ON DISPLAY	35	SWITCH SYSTEM /WITHOUT NAVIGATION SYS-	
Schematic	36	TEM	76
Wiring Diagram — WARN —	37	System Description	76
Terminals and Reference Value for BCM	46	INTEGRATED SWITCH SYSTEM	76
Work Flow	46	PRECAUTION OF LCD MONITOR	76
Preliminary Inspection	46	POWER SUPPLY AND GROUND	76
CONSULT-II Function	47	AV COMMUNICATION LINE	76
DIAGNOSTIC ITEMS DESCRIPTION	47	VEHICLE INFORMATION SYSTEM	77
CONSULT-II BASIC OPERATION PROCEDURE	47	SETTING OF VEHICLE STATUS	79
DATA MONITOR	48	WARNING INDICATIONS	82
ACTIVE TEST	48	Precautions for AV Control Unit Replacement	84
On Board Diagnosis	49	Component Parts and Harness Connector Location	84
DIAGNOSIS ITEM	49	Schematic	85
SWITCH MONITOR	49	Wiring Diagram — INF/D —	86
Trouble Diagnosis for Door Warning Lamp	50	Schematic	94
Combination Meter Circuit Inspection	50	Wiring Diagram — COMM —	95
Front Door Switch Inspection	51	Terminals and Reference Value for AV Control Unit	101
Rear Door Switch Inspection	52	Terminals and Reference Value for Display	104
Electrical Components Inspection	53	Terminals and Reference Value for Multifunction	
OIL PRESSURE SWITCH	53	Switch	106
DIODE CHECK	53	On Board Self-Diagnosis Function (without CON-	
A/T INDICATOR	54	SULT-II)	108
Wiring Diagram — AT/IND —	54	DESCRIPTION	108
A/T Indicator Does Not Illuminate	55	DIAGNOSIS ITEM	108
WARNING CHIME	56	Self-Diagnosis Mode	109
System Description	56	OPERATION PROCEDURE	109
FUNCTION	56	SELF-DIAGNOSIS RESULT	111
IGNITION KEY WARNING CHIME	56	Confirmation/Adjustment Mode	113
LIGHT WARNING CHIME	56	OPERATION PROCEDURE	113
SEAT BELT WARNING CHIME	57	DISPLAY DIAGNOSIS	114
Component Parts and Harness Connector Location	57	VEHICLE SIGNALS	115
Major Component Parts and Function	57	SPEAKER TEST	115
Schematic	58	AUTO CLIMATE CONTROL	115
Wiring Diagram — CHIME —	59	REARVIEW CAMERA	115
Terminals and Reference Value Chart for BCM	63	CONSULT-II Function	116
Work Flow	63	CONSULT-II BASIC OPERATION PROCEDURE	116
Preliminary Inspection	64	SELF-DIAG RESULTS	117
INSPECTION FOR POWER SUPPLY AND		DATA MONITOR	117
GROUND CIRCUIT	64	VERSION	118
CONSULT-II Function	65	Multifunction Switch Self-Diagnosis Function	118
DIAGNOSTIC ITEMS DESCRIPTION	65	STARTING THE SELF-DIAGNOSIS MODE	118
CONSULT-II BASIC OPERATION PROCEDURE	65	EXITING THE SELF-DIAGNOSIS MODE	118
DATA MONITOR	66	DIAGNOSIS FUNCTION	118
ACTIVE TEST	66	Power Supply and Ground Circuit Inspection for AV	
On Board Diagnosis	67	Control Unit	119
DIAGNOSIS ITEM	67	Power Supply and Ground Circuit Inspection for Dis-	
SWITCH MONITOR	67	play	120
Symptom Chart	68	Inspection of Multifunction Switch for Power Supply	
Warning Chime Circuit Check	69	and Ground Circuit	121
Front Door Switch (Driver side) Inspection	71	Vehicle Speed Signal Inspection	122
Key Switch Insert Signal Inspection	72	Illumination Control Signal Inspection	123
		Ignition Signal Inspection	123

RGB Screen is not Shown	123	Removal and Installation of Display	160	
Color of RGB Image is not Proper	124	REMOVAL	160	A
RGB Screen Is Rolling	126	INSTALLATION	160	
No A/C Display is Shown	127	Disassembly and Assembly for Multifunction Switch	161	B
A/C Operation Is Not Possible	127	Removal and Installation of AV and NAVI Control Unit	162	
No Fuel Information Is Displayed/No Warning Message Is Displayed	127	REMOVAL	162	C
Vehicle Condition Setting Is Not Possible	128	INSTALLATION	162	
Multifunction Switch Does Not Operate	129	CLOCK	163	D
Multifunction Switch Indicator Does Not illuminate	129	Wiring Diagram — CLOCK —	163	
Removal and Installation of Display	130	Removal and Installation	164	D
REMOVAL	130	REMOVAL	164	
INSTALLATION	130	INSTALLATION	164	E
Disassembly and Assembly for Multifunction Switch	131	REAR VIEW MONITOR	165	
Removal and Installation of AV Control Unit	132	System Description	165	F
REMOVAL	132	POWER SUPPLY AND GROUND	165	
INSTALLATION	132	AV COMMUNICATION LINE	165	G
VEHICLE INFORMATION AND INTEGRATED SWITCH SYSTEM /WITH NAVIGATION SYSTEM. 133		REAR VIEW CAMERA OPERATION	165	
System Description	133	FUNCTION OF BACKLIGHT CORRECTION	166	H
INTEGRATED SWITCH SYSTEM	133	Component Parts and Harness Connector Location	166	
PRECAUTION OF LCD MONITOR	133	Schematic	167	I
POWER SUPPLY AND GROUND	133	Wiring Diagram — R/VIEW —	168	
AV COMMUNICATION LINE	133	WITHOUT NAVI	171	J
VEHICLE INFORMATION SYSTEM	134	WITH NAVI	172	
SETTING OF VEHICLE STATUS	136	Terminals and Reference Value for Rear View Camera Control Unit	173	
WARNING INDICATIONS	139	Self-Diagnosis Function	174	
Precautions for AV and NAVI Control Unit Replacement	141	DESCRIPTION	174	
Component Parts and Harness Connector Location	141	DIAGNOSIS ITEM	174	
Schematic	142	Self-Diagnosis Mode	174	
Wiring Diagram — INF/D —	143	OPERATION PROCEDURE	174	
Terminals and Reference Value for AV and NAVI Control Unit	151	Confirmation/Adjustment Mode	174	
Terminals and Reference Value for Display	151	OPERATION PROCEDURE	174	
Terminals and Reference Value for Multifunction Switch	153	Side Distance Guideline Correction	175	DI
On Board Self-Diagnosis Function	154	Power Supply and Ground Circuit Check	177	
DESCRIPTION	154	Rear View Is Not Displayed With The A/T Selector Lever In R-position.	178	L
DIAGNOSIS ITEM	154	The Backlight Correction Does Not Work When The ENTER Switch Is Pressed.	180	
Self-Diagnosis Mode	154	The Rear View Image Is Distorted.	181	M
Confirmation/Adjustment Mode	154	Removal and Installation of Rear View Camera Control Unit	182	
CONSULT-II Function	154	REMOVAL	182	
Multifunction Switch Self-Diagnosis Function	155	INSTALLATION	182	
STARTING THE SELF-DIAGNOSIS MODE	155	Removal and Installation of Rear View Camera	182	
EXITING THE SELF-DIAGNOSIS MODE	155	REMOVAL	182	
DIAGNOSIS FUNCTION	155	INSTALLATION	182	
Power Supply and Ground Circuit Check for AV and NAVI Control Unit	155	VOICE ACTIVATED CONTROL SYSTEM	183	
Power Supply and Ground Circuit Inspection for Display	156	System Description	183	
Power Supply and Ground Circuit Inspection for Multifunction Switch	157	OUTLINE	183	
No Fuel Information Is Displayed/No Warning Message Is Displayed	158	VOICE ACTIVATED CONTROL FUNCTION	183	
Vehicle Condition Setting Is Not Possible	159	AV COMMUNICATION LINE	184	
Multifunction Switch Does Not Operate	160	Schematic	185	
Multifunction Switch Indicator Does Not illuminate	160	Wiring Diagram — VOICE —	186	
		Terminals and Reference Values for Voice Activated Control Module	190	
		Component Parts and Harness Connector Location	191	
		Trouble Diagnoses	192	

THIS CONDITION IS NOT MALFUNCTION	192	vated Control System in Operation)	195
Self-Diagnosis Function	192	No Guide Sound or Beeps	196
DESCRIPTION	192	Voice Activated Control System Not Starting PTT	
DIAGNOSIS ITEM	192	Switch Pushed ON	197
Self-Diagnosis Mode	192	Audio Not Muted with PTT Switch Pushed ON	199
OPERATION PROCEDURE	192	Audio Mute Not Released	200
Confirmation/Adjustment Mode	193	Removal and Installation for Voice Activated Control	
OPERATION PROCEDURE	193	Module	201
Power Supply and Ground Circuit Inspection	194	REMOVAL	201
Voice Command Not Identified (With Voice Acti-		INSTALLATION	201

PRECAUTIONS

PRECAUTIONS

PPF:00001

Precautions for Supplemental Restraint System (SRS) “AIR BAG” and “SEAT BELT PRE-TENSIONER”

EKS006SM

The Supplemental Restraint System such as “AIR BAG” and “SEAT BELT PRE-TENSIONER”, used along with a front seat belt, helps to reduce the risk or severity of injury to the driver and front passenger for certain types of collision. This system includes seat belt switch inputs and dual stage front air bag modules. The SRS system uses the seat belt switches to determine the front air bag deployment, and may only deploy one front air bag, depending on the severity of a collision and whether the front occupants are belted or unbelted. Information necessary to service the system safely is included in the SRS and SB section of this Service Manual.

WARNING:

- To avoid rendering the SRS inoperative, which could increase the risk of personal injury or death in the event of a collision which would result in air bag inflation, all maintenance must be performed by an authorized NISSAN/INFINITI dealer.
- Improper maintenance, including incorrect removal and installation of the SRS, can lead to personal injury caused by unintentional activation of the system. For removal of Spiral Cable and Air Bag Module, see the SRS section.
- Do not use electrical test equipment on any circuit related to the SRS unless instructed to in this Service Manual. SRS wiring harnesses can be identified by yellow and/or orange harnesses or harness connectors.

Wiring Diagrams and Trouble Diagnosis

EKS006SN

When you read wiring diagrams, refer to the following:

- Refer to [GI-14, "How to Read Wiring Diagrams"](#) .
- Refer to [PG-2, "POWER SUPPLY ROUTING"](#) for power distribution circuit.

When you perform trouble diagnosis, refer to the following:

- Refer to [GI-10, "HOW TO FOLLOW TEST GROUPS IN TROUBLE DIAGNOSES"](#) .
- Refer to [GI-26, "How to Perform Efficient Diagnosis for an Electrical Incident"](#) .

A

B

C

D

E

F

G

H

I

J

DI

L

M

PREPARATION

PREPARATION

PFP:00002

Commercial Service Tools

EKS007AB

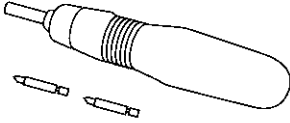
Tool name	Description
<p data-bbox="140 410 252 436">Power tool</p>  <p data-bbox="836 512 911 532">PBIC0191E</p>	<p data-bbox="999 312 1254 338">Loosening bolts and nuts</p>

COMBINATION METERS

COMBINATION METERS

PFP:24814

System Description UNIFIED CONTROL METER

EKS0002T

- Speedometer, odo/trip meter, tachometer, fuel gauge and water temperature gauge are controlled totally by control unit built in combination meter.
- Digital meter is adopted for odo/trip meter.*
*The record of the odo meter is kept even if the battery cable is disconnected. The record of the trip meter is erased when the battery cable is disconnected.
- Odo/trip meter, A/T indicator and ICC system display segments can be checked in self-diagnosis mode.
- Meter/gauge can be checked in self-diagnosis mode.

HOW TO CHANGE THE DISPLAY FOR ODO/TRIP METER

- The CAN communication signals (vehicle speed signal) from VDC/TCS/ABS control unit, and the memory signals from the meter memory circuit are processed by the combination meter, and the mileage is displayed.
- Operating the odometer/trip switch allows switching the mode in the following order.

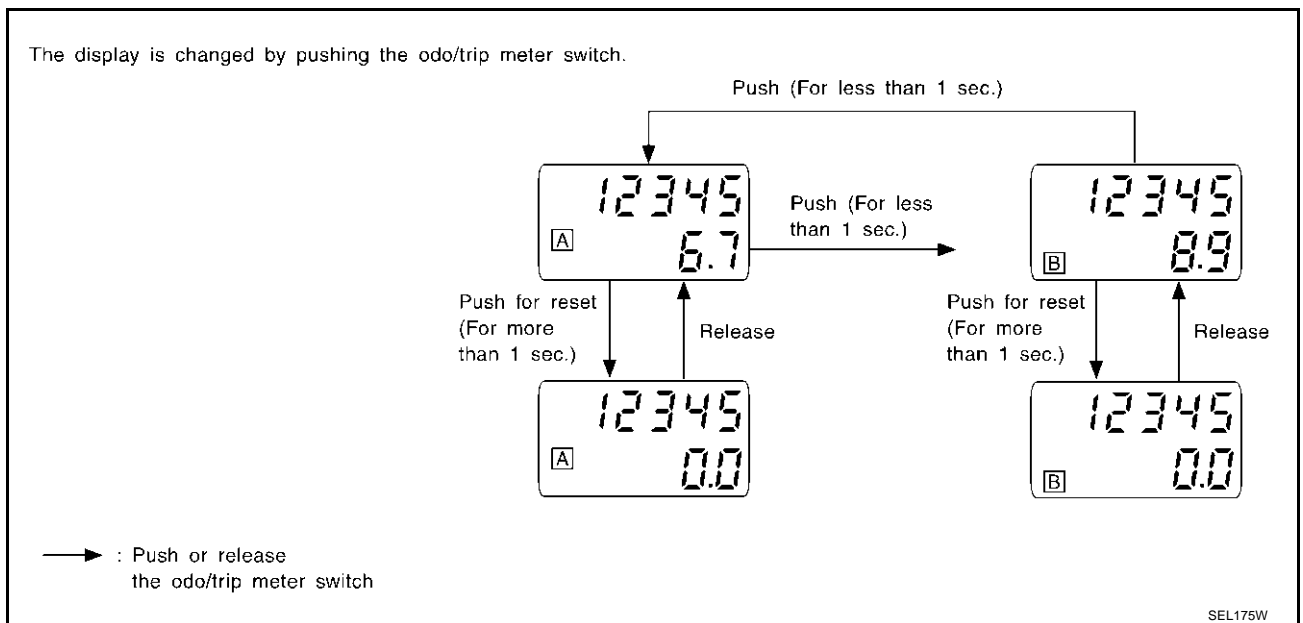

- The odo/trip meter display switching and trip display resetting can be identified by the time from pressing the odo/trip meter switch to releasing it.
- When resetting with trip A displayed, only trip A display is reset (same as trip B).

POWER SUPPLY AND GROUND CIRCUIT

Power is supplied at all times

- through 10A fuse [No. 6, located in the fuse block (J/B) No. 1]
- to combination meter terminal 57.

With the ignition switch in the ON or START position, power is supplied

- through 10A fuse [No. 9, located in the fuse block (J/B) No. 1]
- to combination meter terminal 59.

With the ignition switch in the ACC or ON position, power is supplied

- through 10A fuse [No. 21, located in the fuse block (J/B) No. 1]
- to combination meter terminal 1.

Ground is supplied

- to combination meter terminal 60 and 61
- through grounds M24 and M114.

COMBINATION METERS

WATER TEMPERATURE GAUGE

The water temperature gauge indicates the engine coolant temperature. ECM provides an engine coolant temperature signal to combination meter for water temperature gauge with CAN communication line.

TACHOMETER

The tachometer indicates engine speed in revolution per minutes (rpm). ECM provides an engine speed signal to combination meter for tachometer with CAN communication line.

FUEL GAUGE

The fuel gauge indicates the approximate fuel level in the fuel tank. The fuel gauge is regulated by a variable resistor signal supplied

- to combination meter terminal 30 for the fuel level sensor
- from terminal 5 of the fuel level sensor unit
- through terminal 6 of the fuel level sensor unit and
- through combination meter terminal 29

SPEEDOMETER

VDC/TCS/ABS control unit provides a vehicle speed signal to the combination meter for the speedometer with CAN communication line.

COMBINATION METERS

CAN Communication SYSTEM DESCRIPTION

EKS007AA

CAN (Controller Area Network) is a serial communication line for real time application. It is an on-vehicle multiplex communication line with high data communication speed and excellent error detection ability. Many electronic control units are equipped onto a vehicle, and each control unit shares information and links with other control units during operation (not independent). In CAN communication, control units are connected with 2 communication lines (CAN H line, CAN L line) allowing a high rate of information transmission with less wiring. Each control unit transmits/receives data but selectively reads required data only.

FOR VDC MODELS

System Diagram

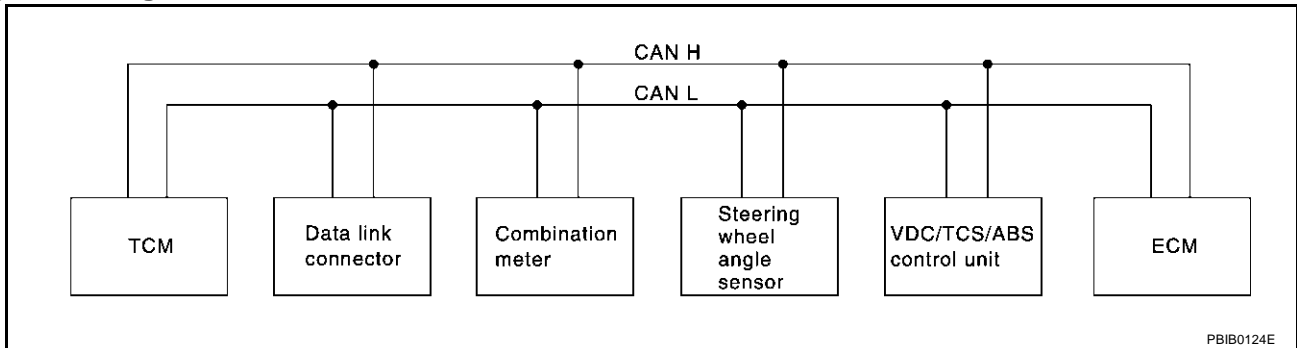

Input/Output Signal Chart

T: Transmit R: Receive

Signals	TCM	Combination meter	Steering wheel angle sensor	VDC / TCS / ABS control unit	ECM
Engine speed signal	R	R		R	T
Engine coolant temperature signal	R	R			T
Accelerator pedal position signal	R			R	T
Engine torque signal	R			R	T
Battery voltage signal	R				T
Closed throttle position signal	R				T
Wide-open throttle position signal	R				T
Lock-up prohibition signal	R				T
Torque-down permission signal	R				T
Fuel consumption monitor signal		R			T
Lock-up signal	T				R
Hard deceleration signal	T				R
Torque-down signal	T				R
Power mode indicator signal	T				R
ATF temperature warning lamp signal	T	R			R
Current gear position signal	T	R		R	R
	R	T			
Next gear position signal	T			R	R
Shift change signal	T			R	R
Shift pattern signal	T				R
VDC system control signal				T	R
VDC operation signal				T	R
Stop lamp switch signal	R			T	
Steering wheel angle sensor signal	R		T	R	R

COMBINATION METERS

Signals	TCM	Combination meter	Steering wheel angle sensor	VDC / TCS / ABS control unit	ECM
A/C switch signal		T			R
Headlamp switch signal		T			R
Rear window defogger switch signal		T			R
OD cancel switch signal	R	T		R	
Brake switch signal	R	T			
Power mode switch signal	R	T			
Vehicle speed signal	R	R		T	
	R	T			R
	T				R

FOR ICC MODELS

System Diagram

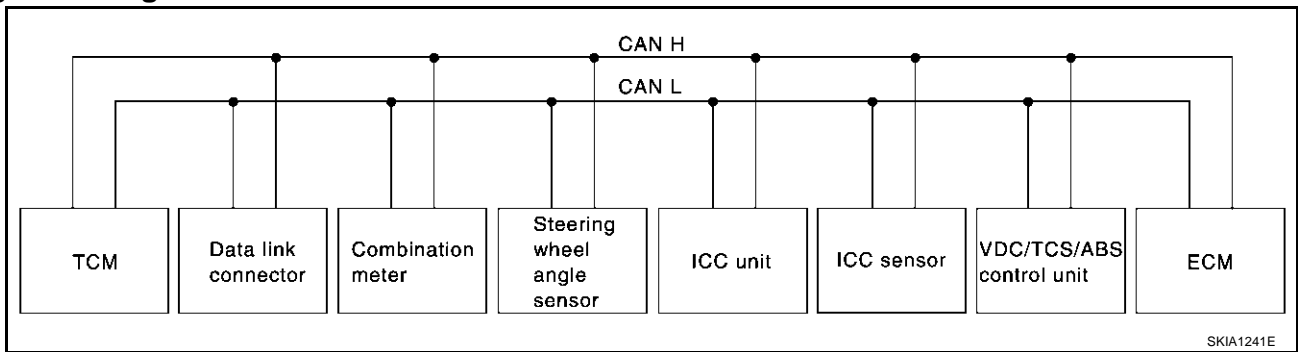

Input/Output Signal Chart

T: Transmit R: Receive

Signals	TCM	Combination meter	Steering wheel angle sensor	ICC unit	ICC sensor	VDC / TCS / ABS control unit	ECM
ICC system display signal		R		T			
ICC sensor signal				R	T		
Engine speed signal	R	R		R		R	T
Engine coolant temperature signal	R	R					T
Accelerator pedal position signal	R					R	T
Engine torque signal	R					R	T
Battery voltage signal	R						T
Closed throttle position signal	R			R			T
Lock-up prohibition signal	R						T
Torque-down permission signal	R						T
Fuel consumption monitor signal		R					T
Lock-up signal	T						R
Hard deceleration signal	T						R
Torque-down signal	T						R
Power mode indicator signal	T						R
ATF temperature warning lamp signal	T	R					R
	R	T					R
Current gear position signal	T	R				R	R
	R	T					
Next gear position signal	T					R	R

COMBINATION METERS

Signals	TCM	Combina- tion meter	Steering wheel angle sensor	ICC unit	ICC sen- sor	VDC / TCS / ABS con- trol unit	ECM
Shift change signal	T					R	R
Shift pattern signal	T			R			R
VDC system control signal						T	R
VDC operation signal				R		T	R
Stop lamp switch signal	R					T	
Steering wheel angle sensor signal	R		T			R	R
A/C switch signal		T					R
Headlamp switch signal		T					R
Rear window defogger switch signal		T					R
OD cancel switch signal	R	T				R	
Brake switch signal	R	T					
Power mode switch signal	R	T					
Vehicle speed signal	R	R		R		T	
	R	T					R
	T			R			R

Component Parts and Harness Connector Location

EKS000ZU

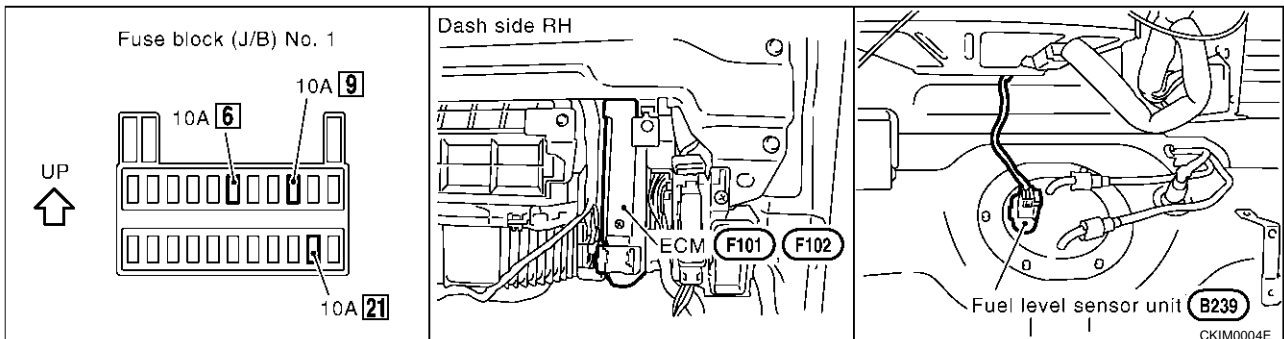

COMBINATION METERS

Combination Meter/Without ICC System CHECK

EKS003KW

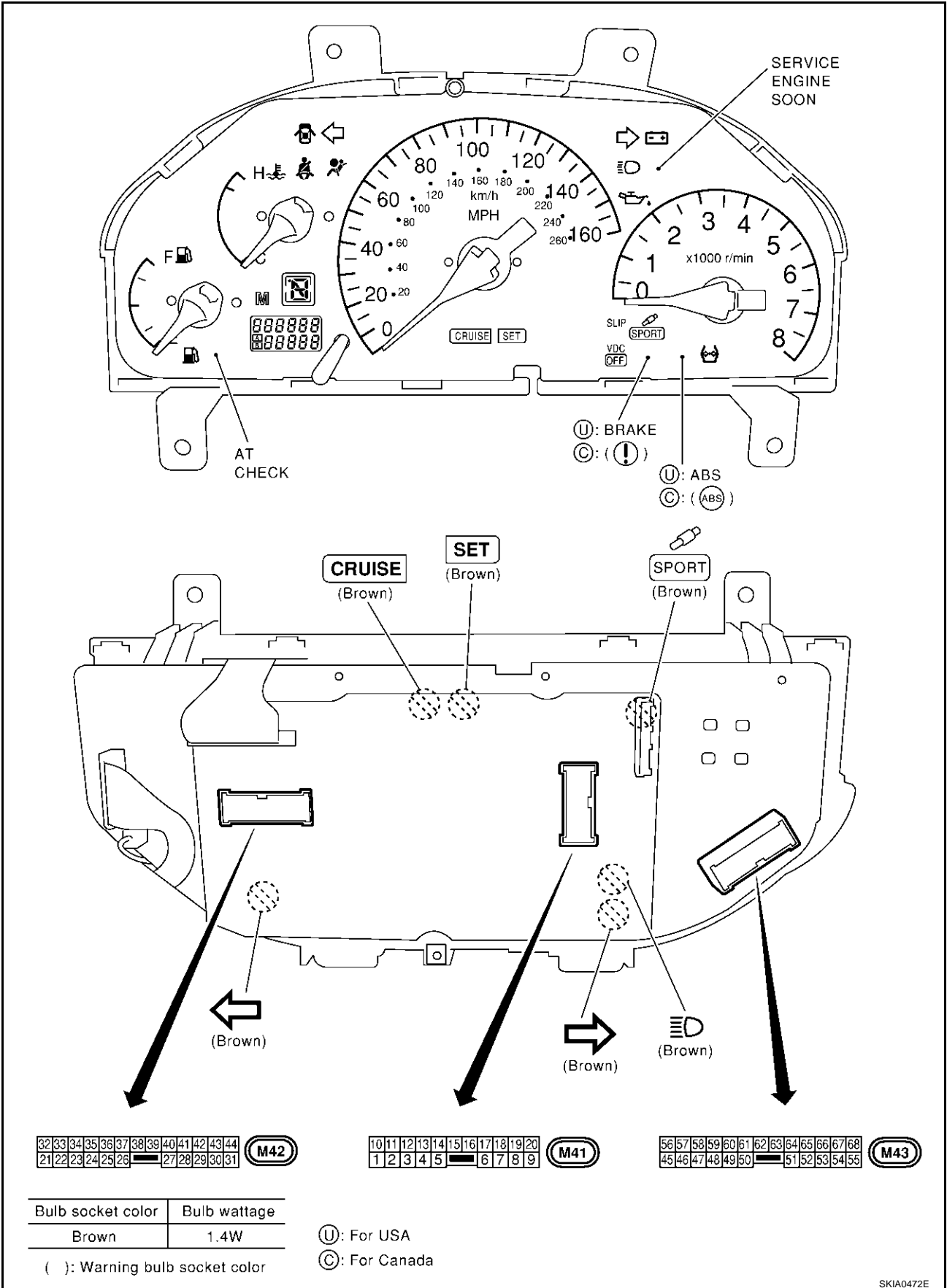

SKIA0472E

COMBINATION METERS

Combination Meter/With ICC System CHECK

EKS0018P

A
B
C
D
E
F
G
H
I
J
DI
L
M

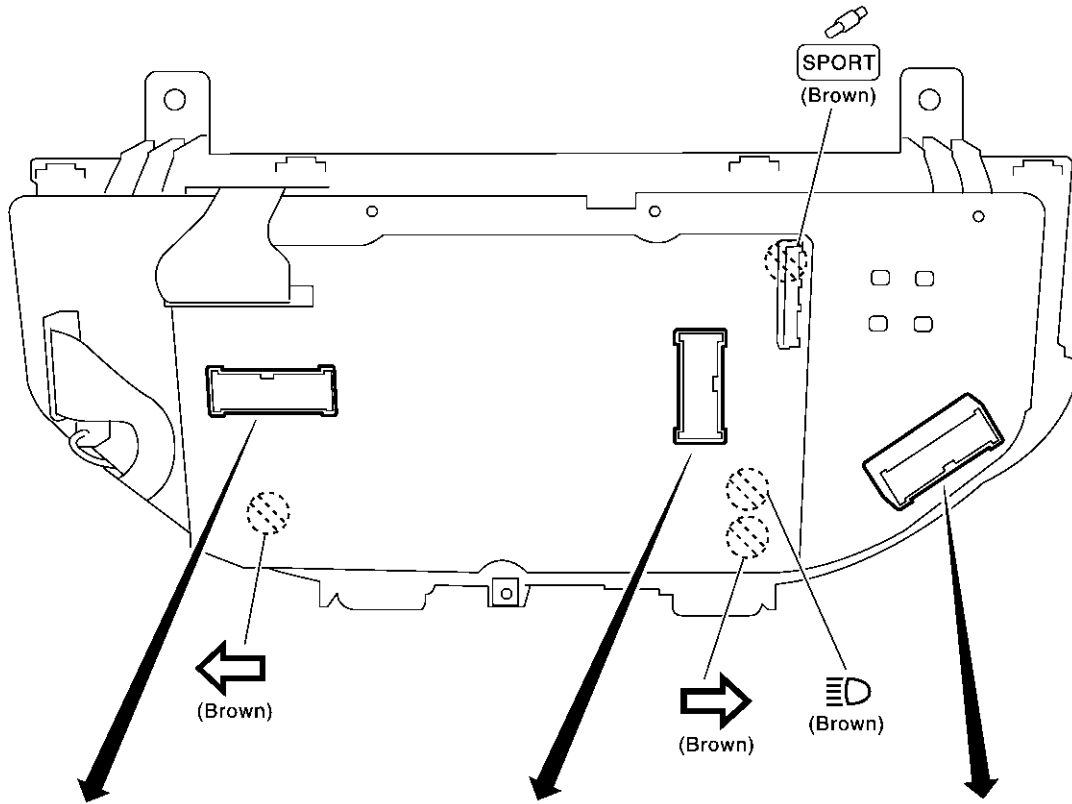
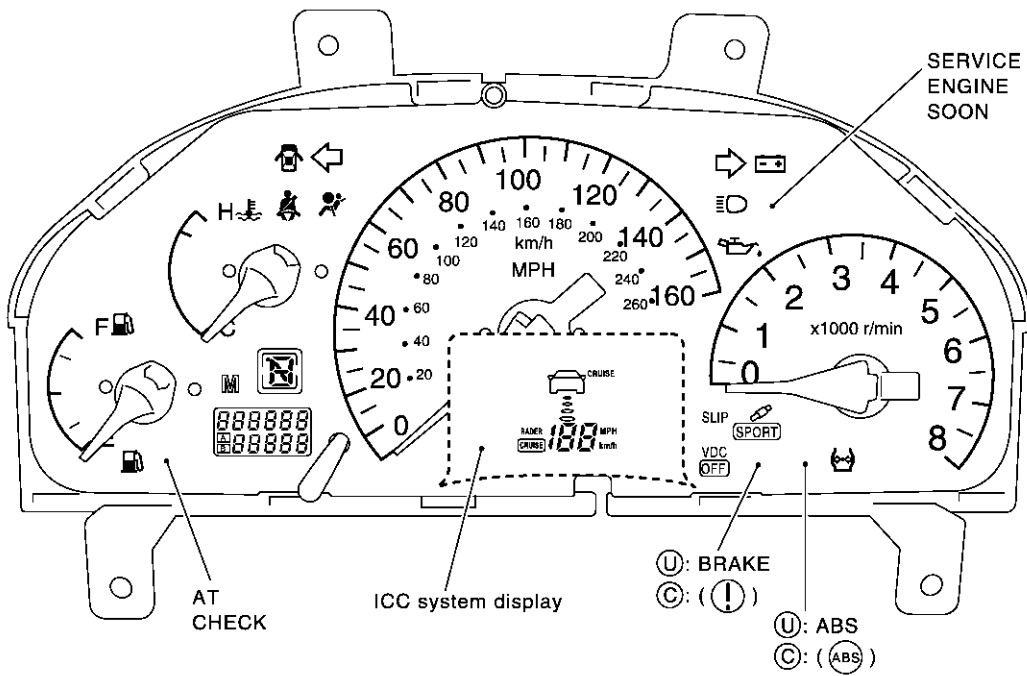

32	33	34	35	36	37	38	39	40	41	42	43	44
21	22	23	24	25	26	27	28	29	30	31	M42	

10	11	12	13	14	15	16	17	18	19	20
1	2	3	4	5	6	7	8	9	M41	

56	57	58	59	60	61	62	63	64	65	66	67	68
45	46	47	48	49	50	51	52	53	54	55	M43	

Bulb socket color	Bulb wattage
Brown	1.4W

() : Warning bulb socket color

U: For USA
C: For Canada

SKIA1169E

COMBINATION METERS

Schematic

EKS000ZW

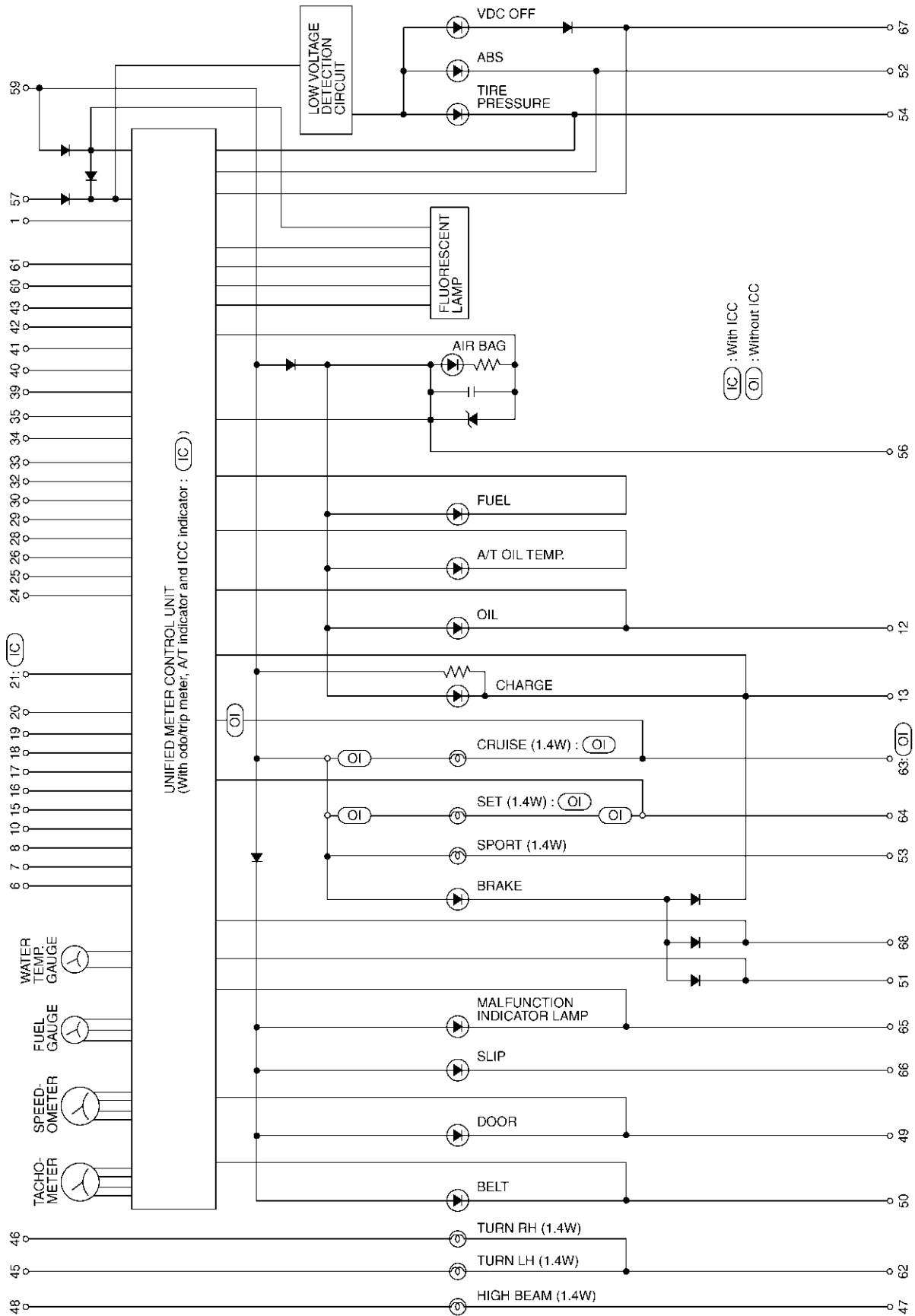

TKWM0215E

COMBINATION METERS

Wiring Diagram — METER —

EKS00184

DI-METER-01

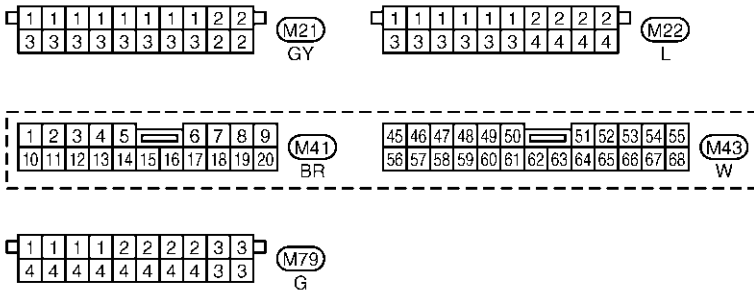
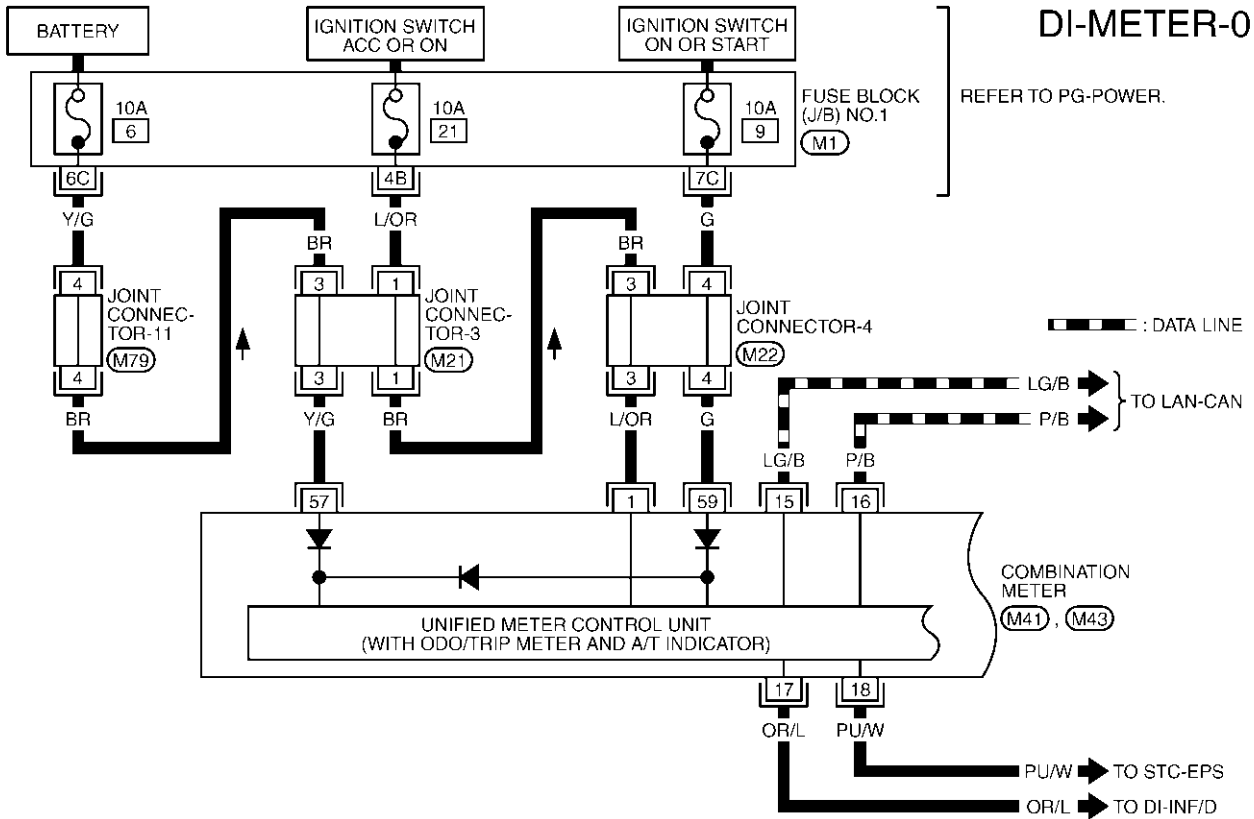

REFER TO THE FOLLOWING.
 (M1) - FUSE BLOCK-JUNCTION BOX (J/B) NO.1

TKWM0060E

COMBINATION METERS

DI-METER-02

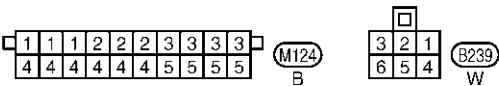
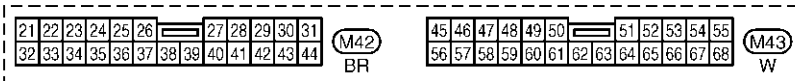
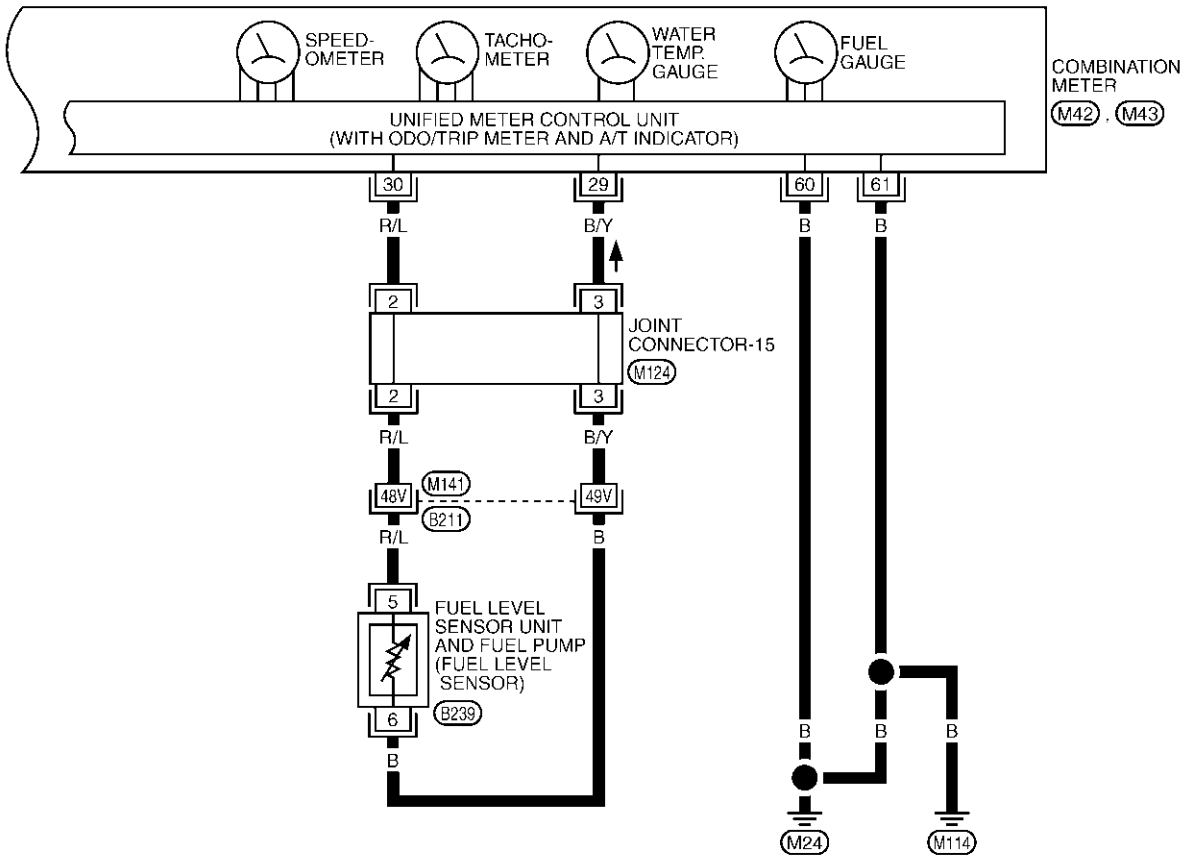

REFER TO THE FOLLOWING.

(B211) -SUPER MULTIPLE JUNCTION (SMJ)

TKWM0422E

COMBINATION METERS

Terminals and Reference Value for Combination Meter

EKS000ZY

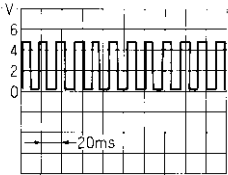
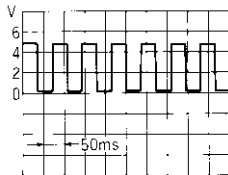
Terminal No.	Wire color	Item	Condition		Reference value (V)
			Ignition switch	Operation	
1	L/OR	Ignition switch (ACC)	ACC	—	Battery voltage
15	LG/B	CAN L	—	—	—
16	P/B	CAN H	—	—	—
17	OR/L	Vehicle speed signal (8-pulse)	ON	Speedometer operated [When vehicle speed is approx. 40 km/h (25MPH)]	
18	PU/W	Vehicle speed signal (2-pulse)	ON	Speedometer operated [When vehicle speed is approx. 40 km/h (25MPH)]	
29	B/Y	Fuel level sensor ground	ON	—	Approx. 0
30	R/L	Fuel level sensor signal	ON	—	Refer to DI-26, "Electrical Components Inspection" .
57	Y/G	Battery power supply	OFF	—	Battery voltage
59	G	Ignition switch (ON)	ON	—	Battery voltage
60	B	Ground	ON	—	Approx. 0
61	B	Ground	ON	—	Approx. 0

A
B
C
D
E
F
G
H
I
J

DI

L
M

COMBINATION METERS

Meter/Gauges Operation, Odo/Trip Meter, A/T Indicator and ICC System Display

EKS000ZZ

SELF-DIAGNOSIS FUNCTION

- Odo/trip meter segment, A/T indicator segment and ICC system display segment can be checked in self-diagnosis mode.
- Meters/gauges can be checked in self-diagnoses mode.

HOW TO ALTERNATE DIAGNOSIS MODE

1. Turn the ignition switch ON, and switch the odo/trip meter to “trip A” or “trip B”.

NOTE:

If the diagnosis function is activated with the trip meter A displayed, the mileage on the trip meter A is reset to 0.0 km (same as the trip meter B display).

2. Turn the ignition switch OFF.
3. While pushing the odo/trip meter switch, turn the ignition switch ON again.
4. Check that the trip meter displays “0000.0”.
5. Push the odo/trip meter switch at least 3 times within 5 seconds.
6. All the segments on the odo/trip meter, A/T indicator and ICC system display illuminate, and simultaneously the low-fuel warning lamp indicator illuminate. At this time, the unified control meter is turned to diagnosis mode.

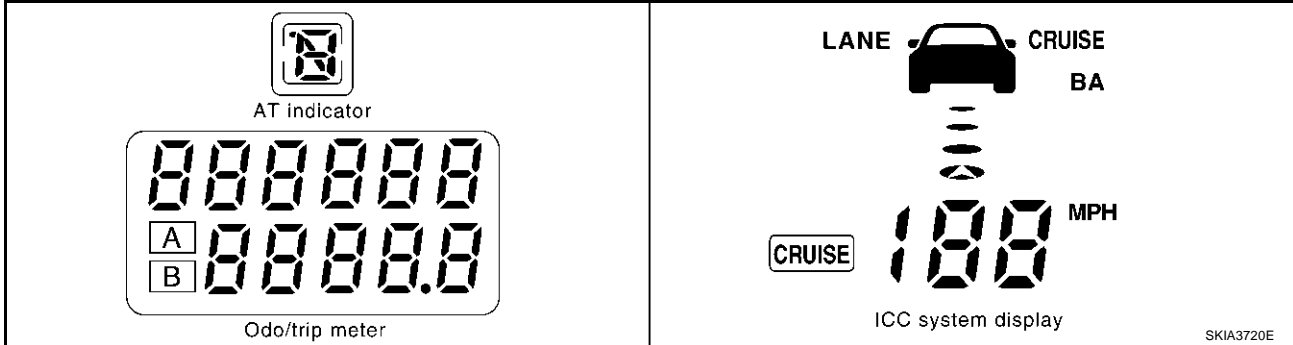

NOTE:

If any of the segments is not displayed, replace the odo/trip meter and A/T indicator with the speedometer assembly.

7. Push the odo/trip meter switch. Indication of each meter/gauge should be as shown in the right during pushing odo/trip meter switch if there is no malfunctioning. (at this time, the low-fuel warning lamp goes off).

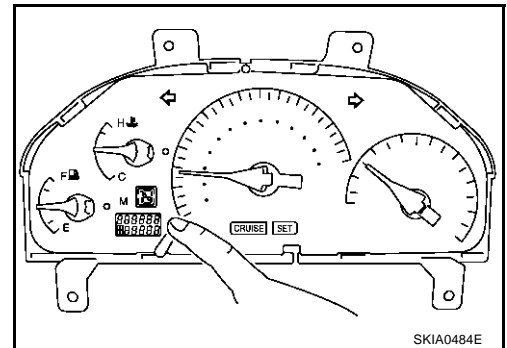

COMBINATION METERS

EKS001C6

Work Flow

1. CHECK WARNING LAMPS

1. Turn ignition switch ON.
2. Warning lamps should illuminate (seat belt warning or door warning etc.).

Do warning lamps illuminate?

YES >> GO TO 2.

NO >> Power supply and ground check. Refer to [DI-21, "Power Supply and Ground Circuit Check"](#).

2. CHECK INDICATOR LAMPS

Meter/gauges/A/T indicator should indicate.

Do indicators indicate?

YES >> GO TO 3.

NO >> Fluorescent lamp check. Refer to [DI-22, "Fluorescent Lamp Check"](#).

3. CHECK SELF-DIAGNOSIS MODE OPERATION

Perform self-diagnosis mode. Refer to [DI-18, "Meter/Gauges Operation, Odo/Trip Meter, A/T Indicator and ICC System Display"](#)

Can diagnosis mode be activated?

YES >> GO TO 4.

NO >> Replace unified meter control unit (sub).

4. CHECK SEGMENTS

Check odo/trip meter segment, A/T indicator or ICC system display segment.

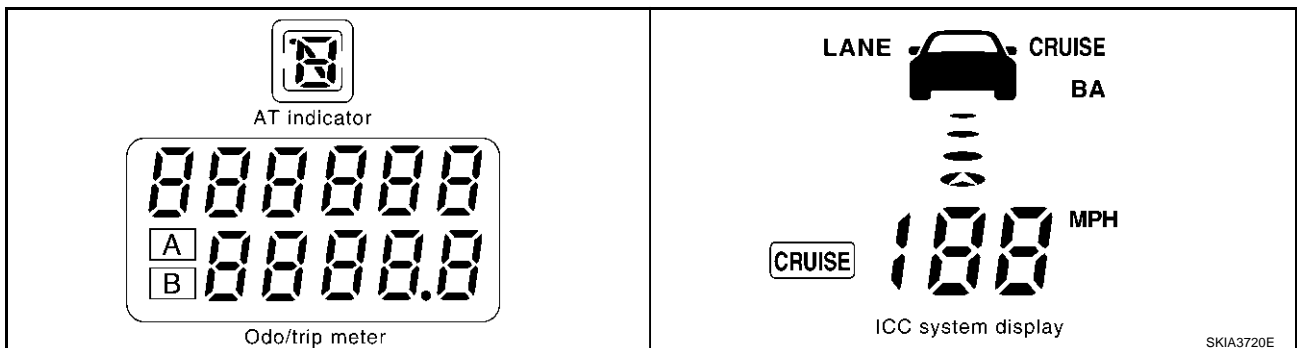

Do all segments illuminate?

YES >> GO TO 5.

NO >> ● Check A/T indicator. Refer to [DI-55, "A/T Indicator Does Not Illuminate"](#).

● Check ICC system display. Refer to [DI-26, "ICC System Display Does Not Illuminate"](#).

● Replace unified meter control unit (sub) and meter and gauge assembly.

5. CHECK SELF-DIAGNOSIS MODE

Check meter/gauge operation in self-diagnosis mode. Refer to [DI-18, "Meter/Gauges Operation, Odo/Trip Meter, A/T Indicator and ICC System Display"](#)

OK or NG

OK >> Symptom chart 2.

NG >> Symptom chart 1.

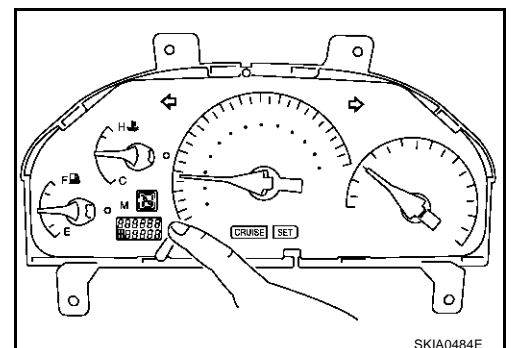

COMBINATION METERS

Trouble Diagnoses

EKS00101

SYMPTOM CHART 1 (MALFUNCTION INDICATED DIAGNOSIS MODE)

Symptom	Possible cause	Repair procedure
Speedometer or odo/trip meter indicate(s) malfunction in diagnosis mode.	<ul style="list-style-type: none"> ● Meter and gauge assembly ● Unified meter control unit 	<ul style="list-style-type: none"> ● Replace unified meter control unit (main and sub) and meter and gauge assembly.
Multiple meter/gauge indicate malfunction in diagnosis mode.	<ul style="list-style-type: none"> ● Harness connector condition ● Unified meter control unit 	<ul style="list-style-type: none"> ● Check connector conditions in combination meter. ● Replace unified meter control unit (sub).
One of speedometer/tachometer/fuel gauge/ water temp. gauge is malfunctioning.	<ul style="list-style-type: none"> ● Meter/Gauge ● Unified meter control unit 	<ul style="list-style-type: none"> ● Replace meter and gauge assembly and replace unified meter control unit (sub).

SYMPTOM CHART 2 (NO MALFUNCTION INDICATED IN DIAGNOSIS MODE)

Symptom	Possible case	Repair order
Speedometer and odo/trip meter are malfunctioning.	<ol style="list-style-type: none"> 1. Signal <ul style="list-style-type: none"> - Speedometer, odo/trip meter 2. Harness connector condition 3. Unified meter control unit 	<ol style="list-style-type: none"> 1. Check vehicle speed signal. INSPECTION/VEHICLE SPEED SIGNAL (Refer to DI-23, "Inspection/Vehicle Speed Signal") 2. Check connector conditions in combination meter. 3. Replace unified meter control unit (sub).
Multiple meter/gauge are malfunctioning, (except for speedometer, odo/trip meter)	<ol style="list-style-type: none"> 1. Harness connector condition 2. Unified meter control unit 	<ol style="list-style-type: none"> 1. Check connector conditions in combination meter. 2. Replace unified meter control unit.
One of tachometer/fuel gauge/ water temp. gauge is malfunctioning.	<ol style="list-style-type: none"> 1. Signal <ul style="list-style-type: none"> - Tachometer - Fuel gauge - Water temp.gauge 2. Harness connector condition 3. Unified meter control unit 	<ol style="list-style-type: none"> 1. Check signal for malfunctioning meter/gauge. <ul style="list-style-type: none"> - INSPECTION/ENGINE SPEED SIGNAL (Refer to DI-22, "Inspection/Engine Speed Signal") - INSPECTION/FUEL LEVEL SENSOR UNIT (Refer to DI-23, "Inspection/Fuel Level Sensor Unit") - INSPECTION/ENGINE COOLANT TEMPERATURE SENSOR. (Refer to DI-23, "Inspection/Water Temperature Gauge") 2. Check connector conditions in combination meter. 3. Replace unified meter control unit (sub).

COMBINATION METERS

Power Supply and Ground Circuit Check

EKS00102

1. CHECK FUSES

Check that any of the fuses in combination meter is blown.

Unit	Power source	Fuse No.
Combination meter	Battery	6
	Ignition switch (ON)	9
	Ignition switch (ACC)	21

OK or NG

OK >> GO TO 2.

NG >> If fuse is blown, be sure to eliminate cause of malfunction before installing new fuse. Refer to [PG-2](#), "POWER SUPPLY ROUTING".

2. CHECK POWER SUPPLY CIRCUIT

1. Disconnect the combination meter connector.
2. Check voltage between combination meter and ground.

Terminals		(-)	Ignition switch position		
(+)			OFF	ACC	ON
Connector	Terminal (Wire color)				
M41	1(L/OR)	Ground	0V	Battery voltage	Battery voltage
M43	57(Y/G)		Battery voltage	Battery voltage	Battery voltage
M43	59(G)		0V	0V	Battery voltage

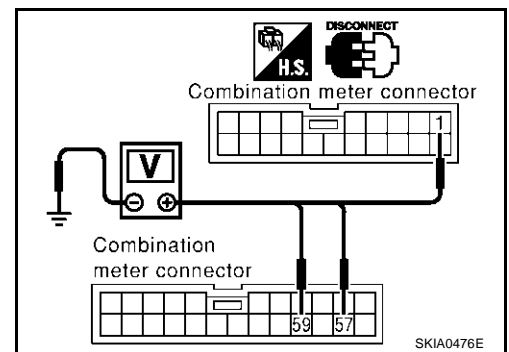

OK or NG

OK >> GO TO 3.

NG >> Check harness for open or short between combination meter and fuse.

3. CHECK GROUND CIRCUIT

Check continuity between combination meter and ground.

Terminals		(-)	Continuity
(+)			
Connector	Terminal (Wire color)		
M43	60 (B)	Ground	Yes
	61 (B)		

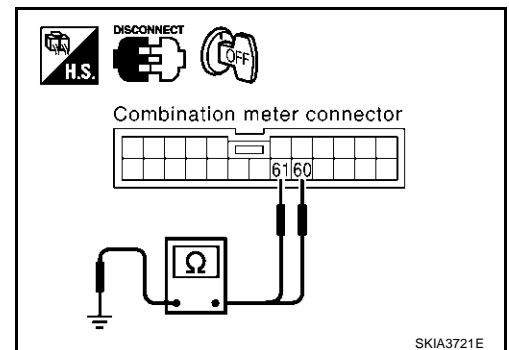

OK or NG

OK >> Inspection end.

NG >> Check ground harness.

COMBINATION METERS

Fluorescent Lamp Check

EKS001C7

1. CHECK FLEXIBLE PRINT CIRCUIT (FPC) CONNECTOR

1. Disconnect fluorescent lamp harness connector.
2. Check terminals for damage or loose connection. Then reconnect connectors.
3. Check FPC connector for damage or loose connection. Then reconnect connector.

OK or NG

- OK >> Replace unified meter control unit (main and sub) and fluorescent lamp.
NG >> ● Repair or replace fluorescent harness connector.
● Repair or replace FPC connector.

Inspection/Engine Speed Signal

EKS00104

1. CHECK VISUAL

At the engine start, does the pointer on the tachometer fluctuate?

Is the fluctuation acceptable?

- YES >> GO TO 2.
NO >> GO TO 3.

2. CHECK ENGINE SPEED

Compare the engine speed and the values indicated in tachometer.

Does the engine speed correspond to the speed indicated?

- YES >> Tachometer is OK.
NO >> Replace unified meter control unit (sub) and meter and gauges assembly.

3. CHECK ECM SYSTEM

Perform ECM self-diagnosis. Refer to [EC-52, "Emission-related Diagnostic Information"](#) .

OK or NG

- YES >> GO TO 4.
NO >> Perform "Diagnostic Procedure" for displayed DTC.

4. CHECK SELF-DIAGNOSIS

Perform the combination meter self-diagnosis mode, refer to [DI-18, "Meter/Gauges Operation, Odo/Trip Meter, A/T Indicator and ICC System Display"](#) .

OK or NG

- OK >> Combination meter is OK.
NG >> Replace unified meter control unit (sub).

COMBINATION METERS

Inspection/Water Temperature Gauge

EKS00105

1. CHECK ECM SYSTEM

Perform the ECM self-diagnosis. Refer to [EC-52, "Emission-related Diagnostic Information"](#).

OK or NG

- OK >> Replace unified meter control unit (sub).
- NG >> Perform "Diagnostic Procedure" for displayed DTC.

Inspection/Vehicle Speed Signal

EKS00106

1. CHECK VDC/TCS/ABS CONTROL UNIT SYSTEM

Perform VDC/TCS/ABS control unit self-diagnosis. Refer to [BRC-26, "CONSULT-II Functions"](#).

OK or NG

- OK >> Replace unified meter control unit (sub).
- NG >> Check VDC/TCS/ABS control unit.

Inspection/Fuel Level Sensor Unit

EKS00107

FUEL LEVEL SENSOR UNIT

The following symptoms do not indicate a malfunction.

- Depending on vehicle posture or driving circumstance, the fuel level in the tank varies, and the pointer may fluctuate.
- If the vehicle is fueled with the ignition switch ON, the pointer will move slowly.

LOW-FUEL WARNING LAMP

Depending on vehicle posture or driving circumstance, the fuel level in the tank varies, and the warning lamp ON timing may be changed.

1. CHECK HARNESS CONNECTOR

1. Turn the ignition switch OFF.
2. Check combination meter, fuel level sensor unit and terminals (meter-side, and harness-side) for poor connection and bend.

OK or NG

- OK >> GO TO 2.
- NG >> Repair terminals or connectors.

2. CHECK HARNESS CONNECTOR OUTPUT SIGNAL

1. Turn the ignition switch ON.
2. Check voltage between combination meter harness connector M42 terminal 30 (R/L) and ground.

Approx. 5V

OK or NG

- OK >> GO TO 3.
- NG >> Replace unified meter control unit (sub).

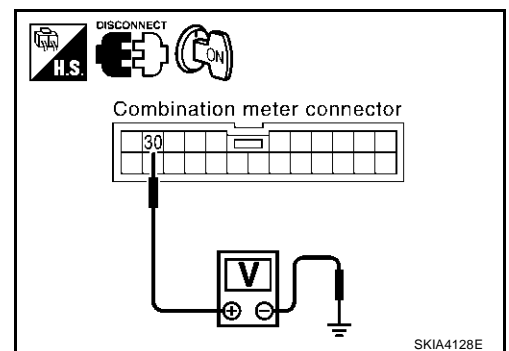

COMBINATION METERS

3. CHECK FUEL LEVEL SENSOR OPEN CIRCUIT

1. Disconnect combination meter connector and fuel level sensor unit connector.
2. Check the following.
 - Continuity between combination meter harness connector M42 terminal 30 (R/L) and fuel level sensor unit harness connector B239 terminal 5 (R/L).

Continuity should exist.

- Check for continuity between combination meter harness connector M42 terminal 29 (B/Y) and the fuel level sensor unit harness connector B239 terminal 6 (B).

Continuity should exist.

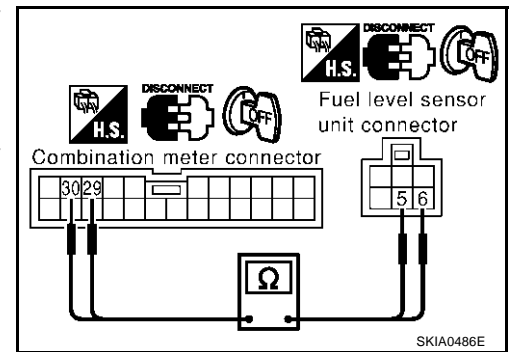

OK or NG

- OK >> GO TO 4.
- NG >> Repair harnesses or connectors.

4. CHECK FUEL LEVEL SENSOR SHORT CIRCUIT

Check continuity between combination meter harness connector M42 terminals 29 (B/Y), 30 (R/L) and ground.

Continuity should not exist.

OK or NG

- OK >> GO TO 5.
- NG >> Repair harnesses or connectors.

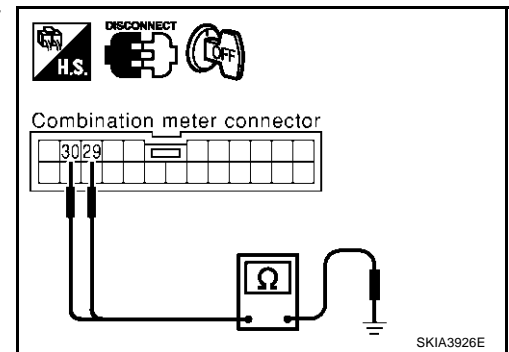

5. CHECK FUEL LEVEL SENSOR UNIT

Check the components. Refer to [DI-26. "CHECK FUEL LEVEL SENSOR UNIT"](#) .

OK or NG

- OK >> GO TO 6.
- NG >> Replace fuel level sensor unit.

6. CHECK INSTALLATION CONDITION

Check fuel level sensor unit installation, and check whether the float arm interferes or binds with any components inside the arm.

OK or NG

- OK >> Replace unified meter control unit (sub).
- NG >> Install fuel level sensor unit properly.

COMBINATION METERS

Fuel Gauge Pointer Fluctuates, Indicator Wrong Value, Or Varies

EKS00108

1. CHECK FUEL GAUGE POINTER FOR FLUCTUATION

Does the indication value fluctuate during driving or before/after stop?

Does the indication value vary?

YES >> The pointer fluctuation may be caused by fuel level change in the fuel tank.

NO >> Ask the customer about the situation when the symptom occurs in detail, and perform the trouble diagnosis.

Fuel Gauge Does Not Move to Full-Position

EKS00109

1. QUESTION 1

Does it take a long time for the pointer to move to Full-position?

YES or NO

YES >> GO TO 2.

NO >> GO TO 3.

2. QUESTION 2

Was the vehicle fueled with the ignition switch ON?

YES or NO

YES >> Be sure to fuel the vehicle with the ignition switch OFF. Otherwise it will take a long time to move to Full-position because of the characteristic of the fuel gauge.

NO >> GO TO 3.

3. QUESTION 3

Is the floor or the vehicle inclined?

YES or NO

YES >> It may not be filled fully.

NO >> GO TO 4.

4. QUESTION 4

During driving, does the fuel gauge pointer move gradually toward E-position?

YES or NO

YES >> Check the components. Refer to [DI-26, "CHECK FUEL LEVEL SENSOR UNIT"](#).

NO >> The float arm may interfere or bind with any of the components in the fuel tank.

Fuel Gauge Does Not Work

EKS0010A

1. CHECK HARNESS CONNECTOR

1. Turn the ignition switch OFF.

2. Check combination meter, fuel level sensor unit, and terminals (meter-side, module-side, lead-side, and harness-side) for poor connection and bend.

OK or NG

OK >> GO TO 2.

NG >> Repair terminals or connectors.

2. CHECK INSTALLATION CONDITION

Check fuel level sensor unit installation (refer to [FL-3, "FUEL LEVEL SENSOR UNIT, FUEL FILTER AND FUEL PUMP ASSEMBLY"](#)), and check whether the float arm interferes or binds with any components inside the arm.

OK or NG

OK >> Fuel level sensor unit is OK.

NG >> Check fuel level sensor unit. Refer to [DI-26, "CHECK FUEL LEVEL SENSOR UNIT"](#).

A
B
C
D
E
F
G
H
I
J
DI
L
M

COMBINATION METERS

Low-Fuel Warning Lamp Illuminate or Not Illuminate

EKS0010B

1. CHECK SELF-DIAGNOSIS

Perform combination meter self-diagnosis mode. Refer to [DI-18, "Meter/Gauges Operation, Odo/Trip Meter, A/T Indicator and ICC System Display"](#) .

OK or NG

OK >> Check fuel level sensor unit. Refer to [DI-26, "CHECK FUEL LEVEL SENSOR UNIT"](#) .

NG >> Replace unified meter control unit (sub).

ICC System Display Does Not Illuminate

EKS003KU

1. ICC SYSTEM DISPLAY CHECK

Does all of ICC system display illuminate?

YES or NO

All of display does not illuminate>>GO TO 2.

Partially does not illuminate>>GO TO 2.

Segment is missing>>GO TO 3.

2. CHECK ICC SYSTEM

Perform ICC unit self-diagnosis. Refer to [ACS-65, "SELF-DIAGNOSIS BY ICC SYSTEM DISPLAY WILL NOT RUN."](#) .

OK or NG

OK >> GO TO 3.

NG >> Check ICC system trouble diagnosis. Refer to [ACS-65, "SELF-DIAGNOSIS BY ICC SYSTEM DISPLAY WILL NOT RUN."](#) .

3. CHECK COMBINATION METER

Perform combination meter self-diagnosis. Refer to [DI-18, "Meter/Gauges Operation, Odo/Trip Meter, A/T Indicator and ICC System Display"](#) .

OK or NG

OK >> ICC system display is OK.

NG >> Replace unified meter control unit (sub) and ICC system display.

Electrical Components Inspection

EKS0010E

CHECK FUEL LEVEL SENSOR UNIT

● For removal, Refer to [FL-3, "FUEL LEVEL SENSOR UNIT, FUEL FILTER AND FUEL PUMP ASSEMBLY"](#)

● Check the resistance between terminals 5 and 6.

Measurement terminal		Float position mm (in)		Resistance value (Ω)
5	6	Full (1)	Approx. 82.7 (3.3)	Approx. 4.5 – 5.5
		1/2 (2)	Approx. 200.3 (7.9)	Approx. 31.5 – 35.5
		Empty (3)	Approx. 325.0 (12.8)	Approx. 80.0 – 83.0

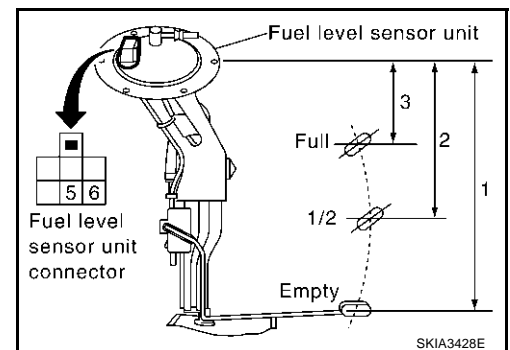

COMBINATION METERS

Removal and Installation for Combination Meter

EKS0010F

REMOVAL

1. Remove the cluster lid A. Refer to [IP-10, "INSTRUMENT PANEL ASSEMBLY"](#) .
2. Remove the screws (4) with power tool, and disconnect connectors.

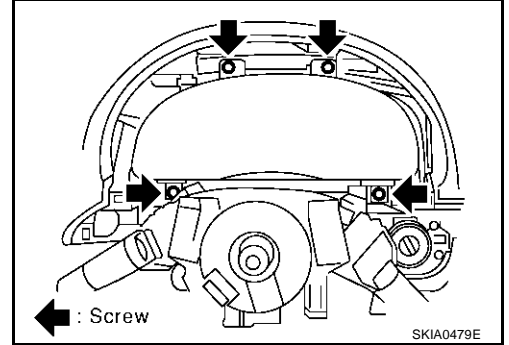

3. Rotating the combination meter so that the left-side is in front, turn it until the meter face comes to the top.

CAUTION:

To prevent it from being damaged by interference with the meter bracket, protect the meter with cloth.

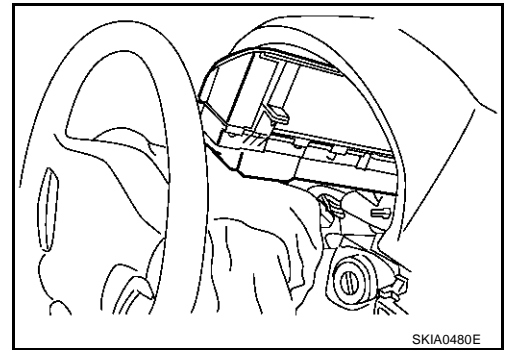

4. While pulling combination meter forward, pull it out to the right (combination meter back-side shall be in front).

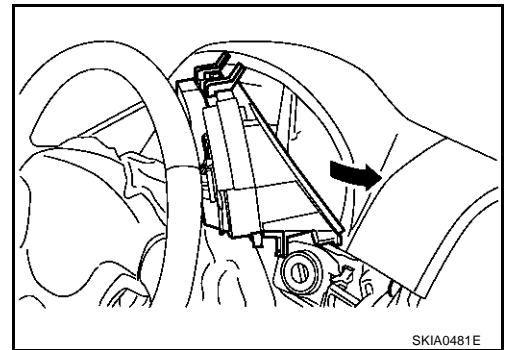

INSTALLATION

Install in the reverse order of removal.

A
B
C
D
E
F
G
H
I
J
DI
L
M

COMBINATION METERS

Disassembly and Assembly for Combination Meter

EKS0010G

SEC. 248

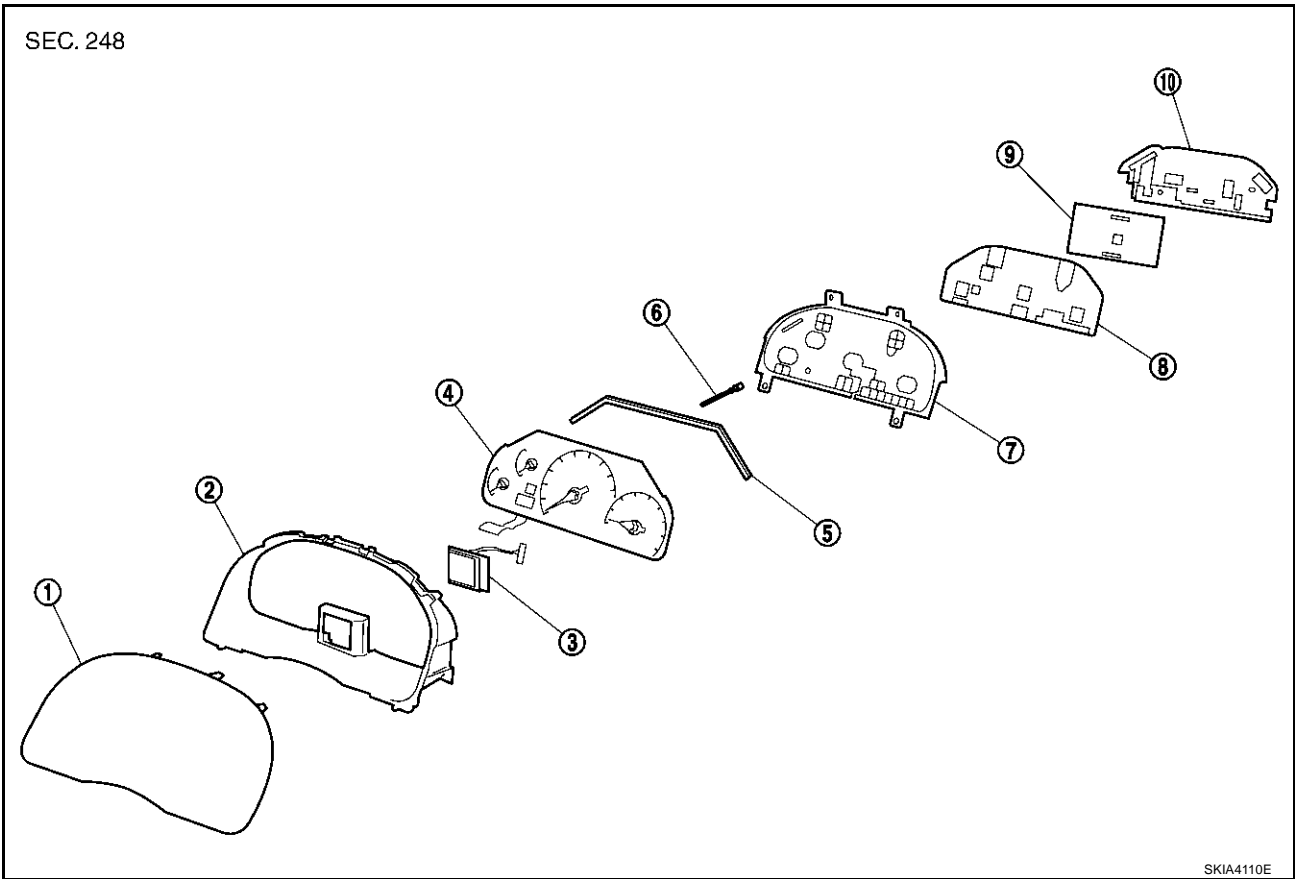

SKIA4110E

- | | | |
|-----------------------------|--------------------------------------|-------------------------------------|
| 1. Front cover | 2. Upper housing | 3. ICC system display |
| 4. Meter and gauge assembly | 5. Fluorescent lamp | 6. Odo/trip meter switch shaft |
| 7. Lower housing | 8. Unified meter control unit (main) | 9. Unified meter control unit (sub) |
| 10. Meter cover | | |

1. Disconnect ICC system display connector.
2. Remove the screws (9) to separate meter cover.
3. Disconnect the connectors for fluorescent lamp connector and flexible printed circuit for fluorescent lamp.
4. Disconnect the flexible printed circuit for odo/trip meter.
5. Remove the screw (1) to separate unified meter control unit (main and sub).
6. Disengage the tabs (8) to separate upper housing.
7. Remove the screw (1) to separate meter and gauge assembly.
8. Disengage the tabs (7) to separate front cover.
9. Separate unified meter control unit (main) from unified meter control unit (sub).

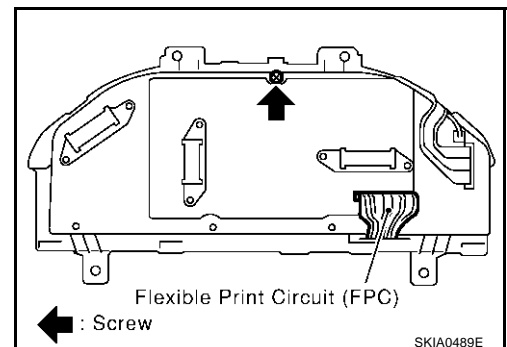
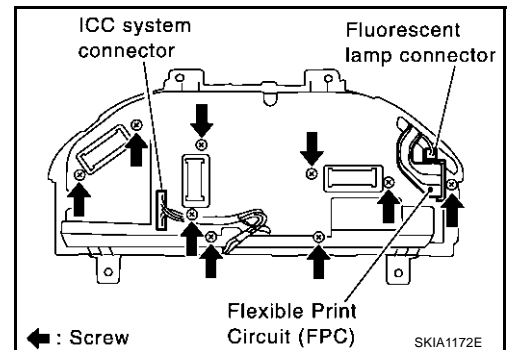

COMPASS

COMPASS

PFP:24835

System Description

EKS006D4

This unit displays earth magnetism and heading direction of vehicle.

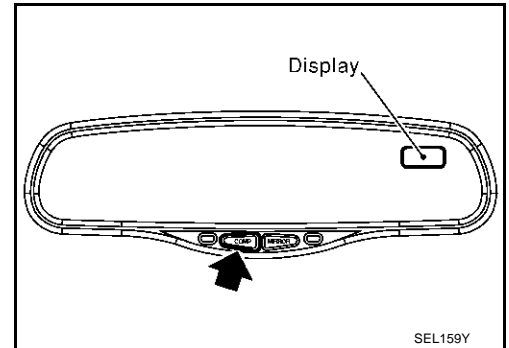

DIRECTION DISPLAY

Push the switch when the ignition key is in the "ON" or "START" position. The direction will be displayed. Pushing the "COMP" switch a second time will turn off the display.

1. If the display reads "C" calibrate the compass by driving the vehicle in 3 complete circles at less than 8 km/h (5 MPH).
2. To adjust for compass variance:
 - a. Press the "COMP" switch for more than 3 seconds. The current zone number will appear in the display.
 - b. Find your current location and variance zone number on the zone map.
 - c. Press the "COMP" switch until the new zone number appears in the display. After you stop pressing the button in, the display will show a compass direction within a few seconds.

NOTE:

1. Do not install the ski rack, antenna, etc. which are attached to the vehicle by means of a magnet. They affect the operation of the compass.
 2. If the compass deviates from the correct indication soon after repeated adjustment, have the compass checked at an authorized dealer.
 3. The compass may not indicate the correct compass point in tunnels or while driving up or down a steep hill. (The compass returns to the correct compass point when the vehicle moves to an area where the geomagnetism is stabilized.)
3. Cleaning the Mirror
When cleaning the mirror, use a paper towel or similar material dampened with glass cleaner. Do not spray glass cleaner directly on the mirror as that may cause the liquid cleaner to enter the mirror housing.

COMPASS

“C” is displayed in the compass window.

The compass needs to be calibrated. Drive the vehicle in 3 circles at 8km/h (5 MPH) or less until the display reads a direction. You can also calibrate the compass by driving your vehicle on your everyday routine. The compass will be calibrated once it has tracked 3 complete circles.

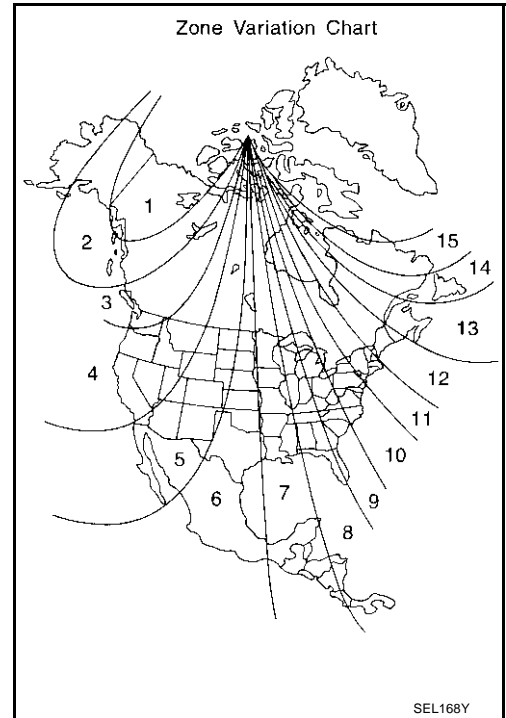

Inaccurate compass direction

1. With the display turned on, push the "COMP" switch for 3 seconds, until the zone selection comes up (a number will be displayed in the mirror compass window).
2. Toggle until correct zone is found and release switch.
3. The display will show all segments, and return to the normal compass mode within 10 seconds of no switch activity.
4. If the vehicle changes zone, repeat steps 1 through 3. See map.

COMPASS

Wiring Diagram – COMPAS –

EKS006D5

DI-COMPAS-01

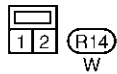
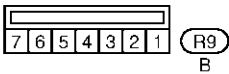
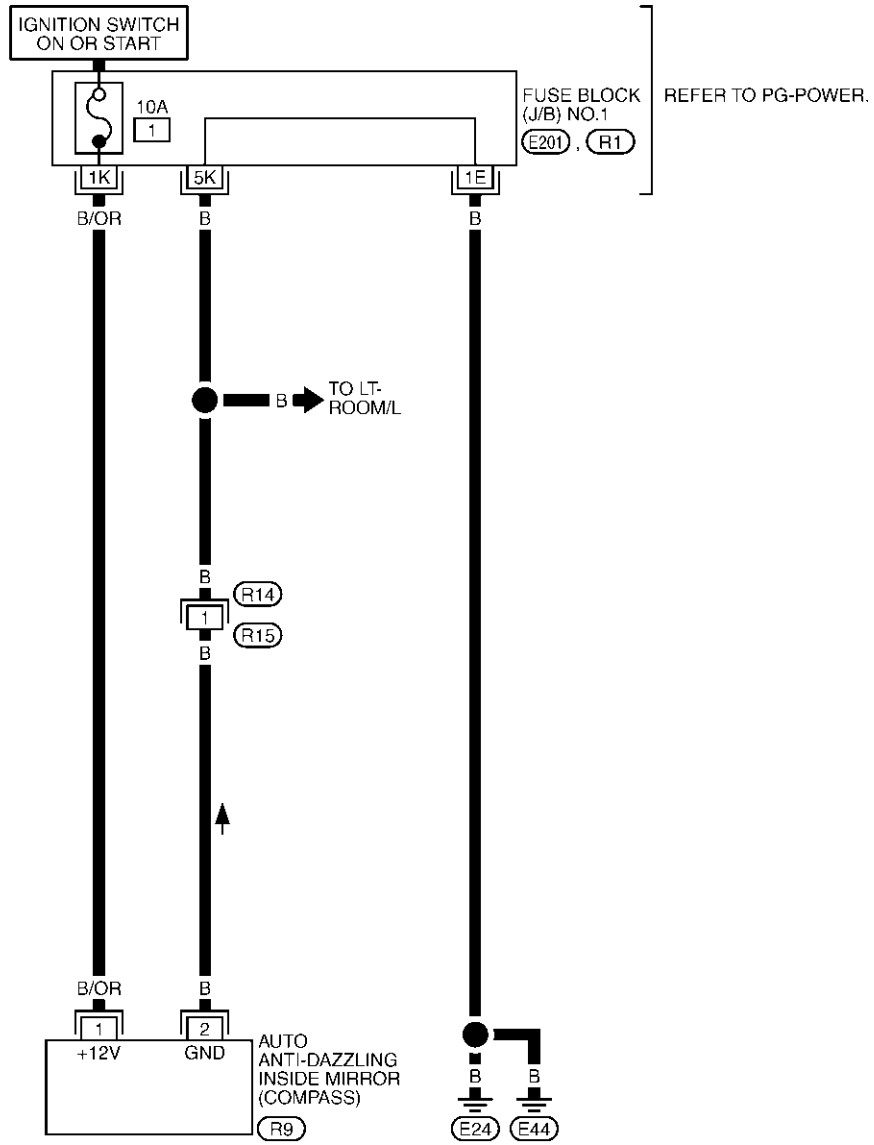

REFER TO THE FOLLOWING.
 (E201), (R1) - FUSE BLOCK-
 JUNCTION BOX (J/B) NO.1

A
B
C
D
E
F
G
H
I
J
DI
L
M

Removal and Installation of Compass

EKS006TN

Refer to [GW-58, "Removal and Installation"](#) .

WARNING LAMPS

PPF:24814

System Description OUTLINE

EKS0010H

Power is supplied at all times

- through 10A fuse [No. 6, located in the fuse block (J/B) No. 1]
- to combination meter terminal 57.

With ignition switch in the ON or START position, power is supplied

- through 10A fuse [No. 9, located in the fuse block (J/B) No. 1]
- to combination meter terminal 59.

Ground is supplied

- to combination meter terminal 60
- through grounds M24 and M114, and
- to seat belt buckle switch terminal 15A
- through grounds B17 and B57, and
- to brake fluid level switch terminal 2
- through grounds E24 and E44, and
- to washer level switch terminal 2
- through grounds E42 and E62.

AIR BAG WARNING LAMP

During probe out or when an air bag malfunction occurs, the ground path is interrupted

- from the air bag diagnosis sensor unit terminal 15
- to combination meter terminal 56.

Ground is supplied

- through combination meter terminal 61

When power and ground are supplied, the air bag warning lamp (LEDs) illuminates.

For further information, refer to [SRS-8, "TROUBLE DIAGNOSIS"](#).

DOOR WARNING LAMP

Door warning lamp is controlled by BCM.

When one of the doors is opened, ground is supplied to the BCM terminals 33, 37, 142 and 143.

And then ground is supplied

- to combination meter terminal 49
- from BCM terminal 111

When power and ground are supplied, the door warning lamp illuminates.

ACTIVE DAMPER INDICATOR LAMP (SPORT)

When an active damper suspension system malfunction occurs, or "SPORT" mode is selected by active damper suspension select switch, ground is supplied

- to combination meter terminal 53
- from active damper suspension control unit terminal 16

When power and ground are supplied, the active damper indicator lamp (SPORT) blinks or illuminates.

For further information.

LOW OIL PRESSURE WARNING LAMP

Low oil pressure causes oil pressure switch terminal 1 to provide ground to combination meter terminal 12.

When power and ground are supplied, the low oil pressure warning lamp illuminates.

CHARGE WARNING LAMP

During prove out or when an alternator malfunction occurs, ground is supplied

- to combination meter terminal 13
- from alternator terminal 3

When power and ground are supplied, the charge warning lamp and brake lamp illuminate.

A

B

C

D

E

F

G

H

I

J

DI

L

M

WARNING LAMPS

LOW WASHER LEVEL WARNING LAMP

When the washer fluid level is low, ground is supplied

- to combination meter terminal 26
- from washer level switch terminal 1.

When power and ground are supplied, the signal is sent

- from combination meter terminal 6 and 7
- through AV and NAVI control unit terminal 32 and 33 or AV control unit terminals 35 and 34
- to display.

Then warning lamp message appears display.

A/T OIL TEMPERATURE WARNING LAMP

When an A/T system malfunction occurs, signal sent

- to combination meter terminals 15 and 16
- from TCM (transmission control module) with CAN communication line.

When signal is received, the AT oil temperature warning lamp blinks or illuminates.

For further information, refer to [AT-239, "A/T CHECK Indicator Lamp Does Not Come On"](#).

LOW-FUEL LEVEL WARNING LAMP

The amount of fuel in the fuel tank is determined by the fuel level sensor in the fuel tank. Fuel level signal is sent

- from fuel level sensor unit terminal 5
- to combination meter terminal 30
- through fuel level sensor unit terminal 6
- to combination meter terminal 29.

The fuel level sensor will illuminate the low-fuel level warning lamp when the fuel level is low.

When power and ground are supplied, the low-fuel level warning lamp illuminates.

ABS WARNING LAMP

When an ABS malfunction occurs, ground is supplied

- to combination meter terminal 52
- from VDC/TCS/ABS control unit terminal 30.

When power and ground is supplied, the ABS warning lamp illuminates.

For further information, refer to [BRC-63, "Symptom 5 Pedal Vibration and Noise"](#).

VDC OFF INDICATOR LAMP

When VDC off switch is in OFF position, or an VDC/TCS/ABS malfunction occurs, ground is supplied

- to combination meter terminal 67
- from VDC/TCS/ABS control unit terminal 31.

When power and ground are supplied, the VDC off warning lamp illuminates.

For further information, refer to [BRC-65, "Symptom 6 VDC OFF Indicator Lamp Does Not Illuminate."](#)

SLIP INDICATOR LAMP

When VDC is in operation, or a VDC malfunction occurs, ground is supplied

- to combination meter terminal 66
- from VDC/TCS/ABS control unit terminal 83.

When power and ground are supplied, the slip warning lamp illuminates.

For further information, refer to [BRC-65, "Symptom 7 SLIP Indicator Lamp Does Not Illuminate."](#)

SEAT BELT WARNING LAMP

When the driver's seat belt is unfastened, ground is supplied

- to combination meter terminal 50
- from seat belt buckle switch terminal 41.

When power and ground are supplied, the seat belt warning lamp illuminates.

WARNING LAMPS

BRAKE WARNING LAMP

When the parking brake is applied, or the brake fluid level is low, ground is supplied

- to combination meter terminal 68
- from parking brake switch terminal 1, or
- to combination meter terminal 51
- brake fluid level switch terminal 1.

When power and ground are supplied, the brake warning lamp illuminates.

MALFUNCTION INDICATOR LAMP

During prove out or when an engine control malfunction occurs, ground is supplied

- to combination meter terminal 65
- from ECM terminal 35.

When power and ground are supplied, the malfunction indicator lamp illuminates.

For further information, refer to [EC-410, "DTC P0650 MIL"](#).

LOW TIRE PRESSURE WARNING LAMP

When a low tire pressure warning control malfunction occurs, ground is supplied

- to combination meter terminal 54
- from low tire pressure warning control unit terminal 3

When power and ground are supplied, the tire pressure warning lamp illuminates.

For further information, refer to [WT-22, "TROUBLE DIAGNOSIS FOR SYMPTOMS"](#).

ASCD WARNING LAMP

When an ASCD malfunction occurs, ground is supplied

- to combination meter terminal 64
- from ASCD control unit terminal 18

When power and ground are supplied, the ASCD warning lamp illuminates.

ICC SYSTEM WARNING LAMP

When an ICC system malfunction occurs, ground is supplied

- to combination meter terminal 21
- from ICC unit terminal 25.

When power and ground are supplied, the ICC system warning lamp illuminates.

WARNING MESSAGE ON DISPLAY

When a warning lamp illuminates or flushes, signal is sent

- from combination meter terminals 6 and 7
- through AV and NAVI control unit terminals 32 and 33 or AV control unit terminals 35 and 34.
- to display.

Then warning message appears on display.

A

B

C

D

E

F

G

H

I

J

DI

L

M

WARNING LAMPS

EKS0010K

Schematic

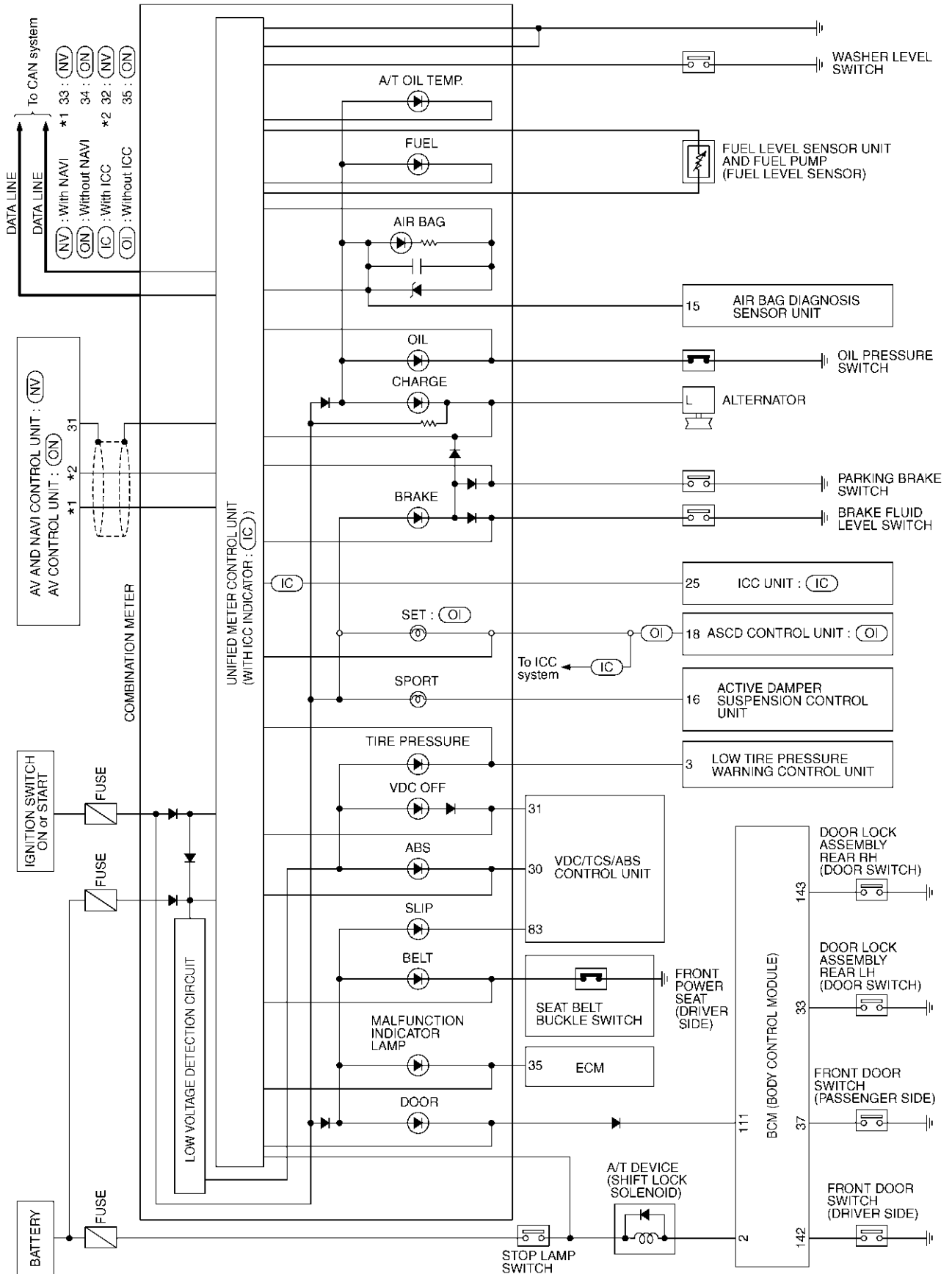

TKWM0263E

WARNING LAMPS

Wiring Diagram — WARN —

EKS0019L

DI-WARN-01

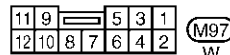
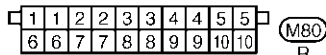
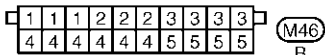
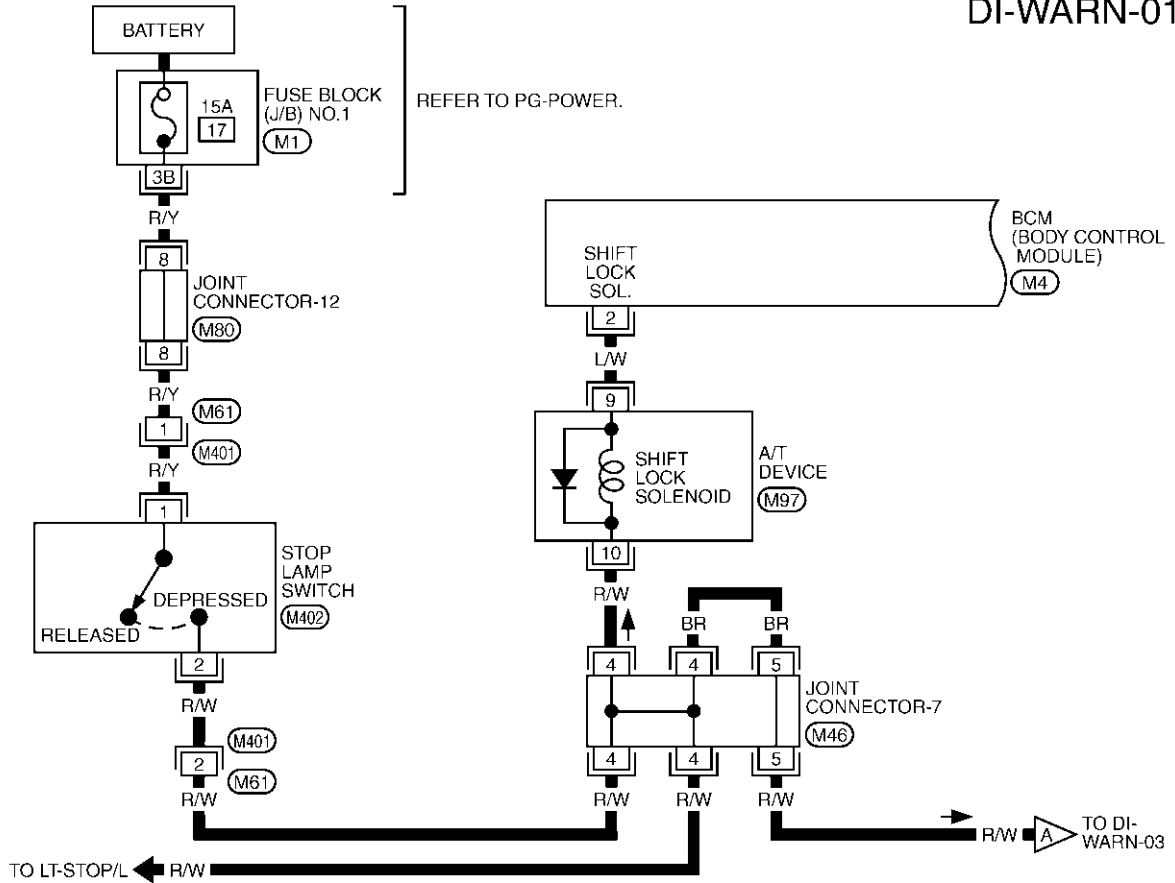

REFER TO THE FOLLOWING.

(M1) - FUSE BLOCK-JUNCTION BOX (J/B) NO.1

(M4) - ELECTRICAL UNITS

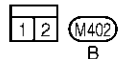
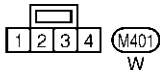

A
B
C
D
E
F
G
H
I
J
DI
L
M

TKWM0063E

WARNING LAMPS

DI-WARN-02

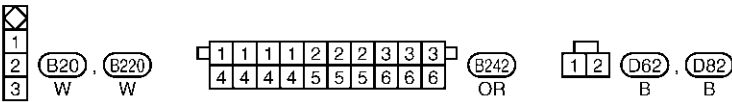
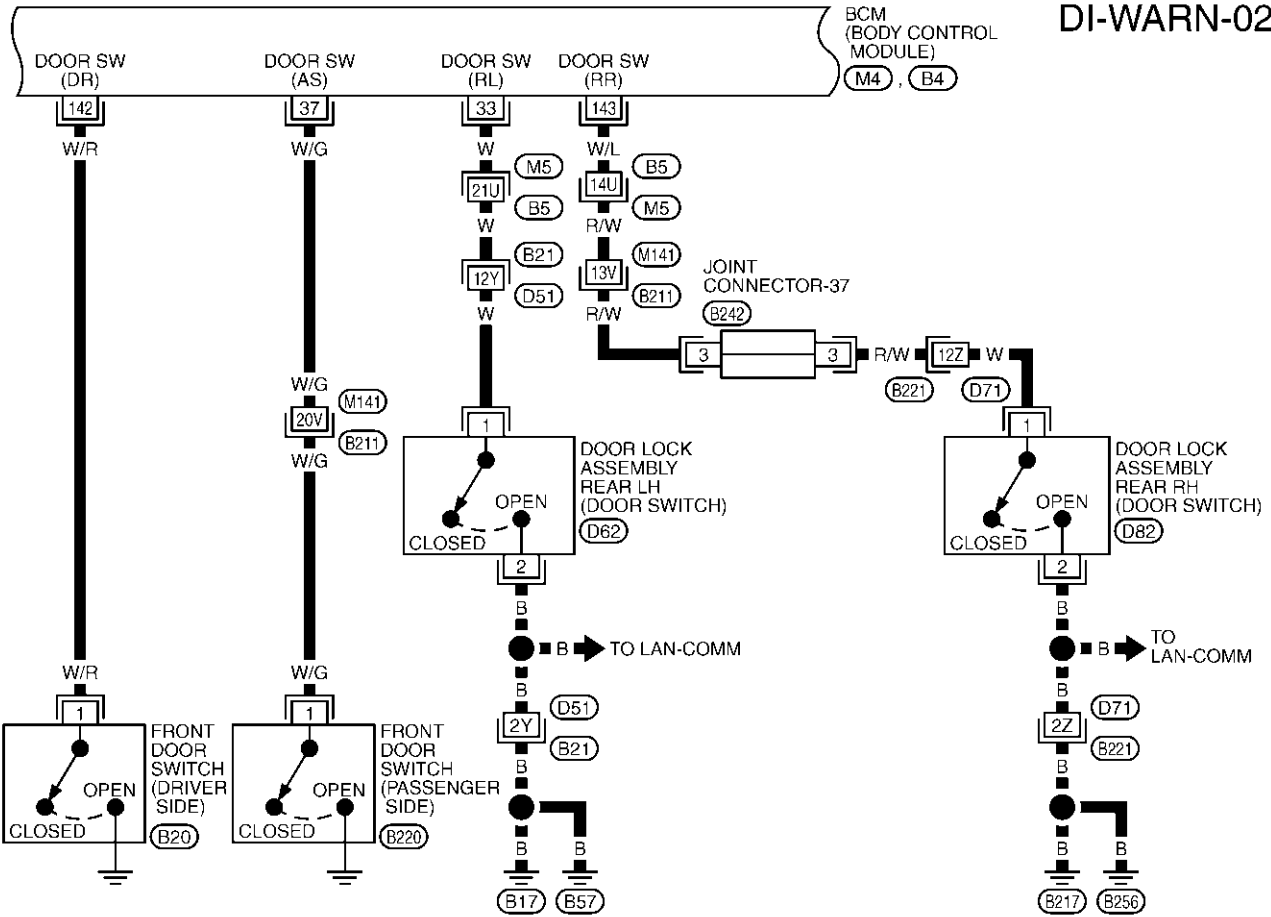

REFER TO THE FOLLOWING.
 (M5), (B21), (B211), (B221)
 -SUPER MULTIPLE JUNCTION (SMJ)
 (M4), (B4) -ELECTRICAL UNITS

TKWM0423E

WARNING LAMPS

DI-WARN-03

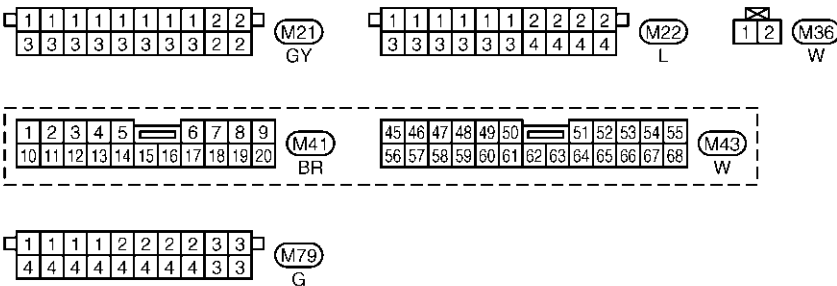
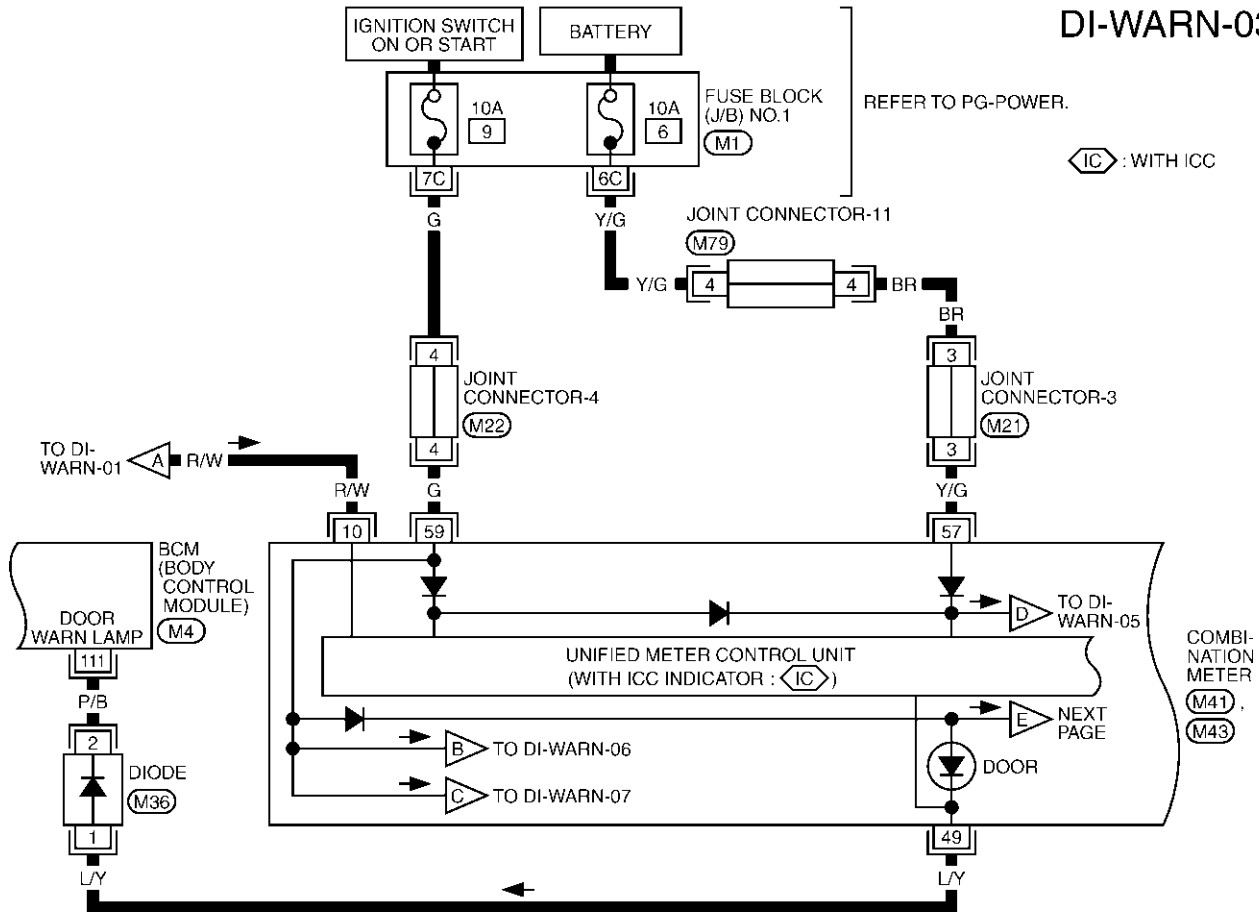

REFER TO THE FOLLOWING.

- (M1) - FUSE BLOCK-JUNCTION BOX (J/B) NO.1
- (M4) - ELECTRICAL UNITS

TKWM0361E

WARNING LAMPS

DI-WARN-04

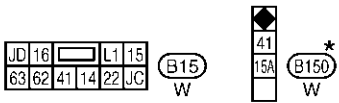
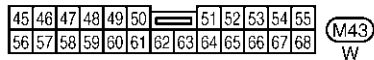
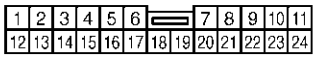
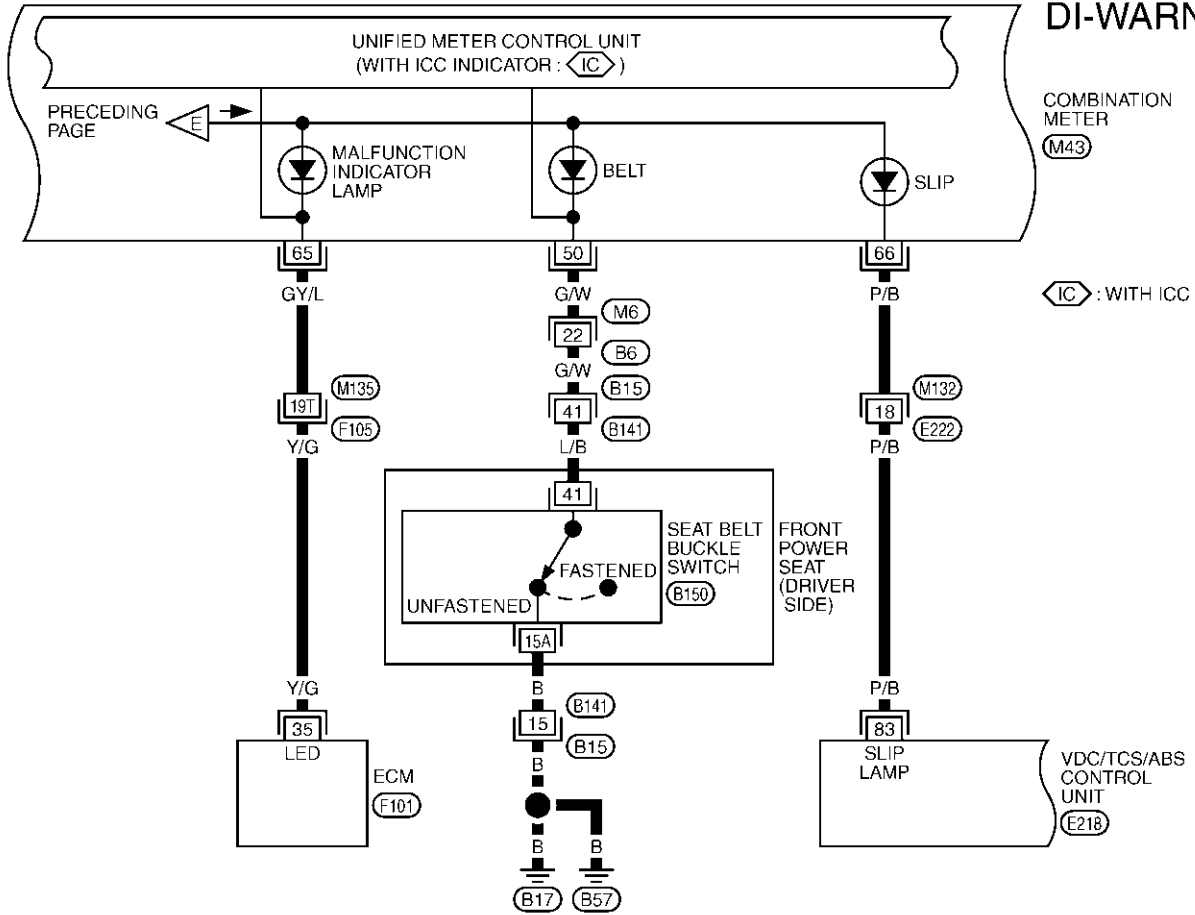

*: THIS CONNECTOR IS NOT SHOWN IN "HARNESS LAYOUT", PG SECTION.

REFER TO THE FOLLOWING.
(F105) -SUPER MULTIPLE JUNCTION (SMJ)
(E218), (F101) -ELECTRICAL UNITS

TKWM0424E

WARNING LAMPS

DI-WARN-05

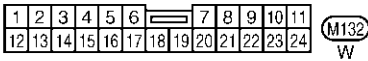
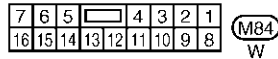
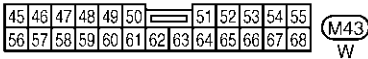
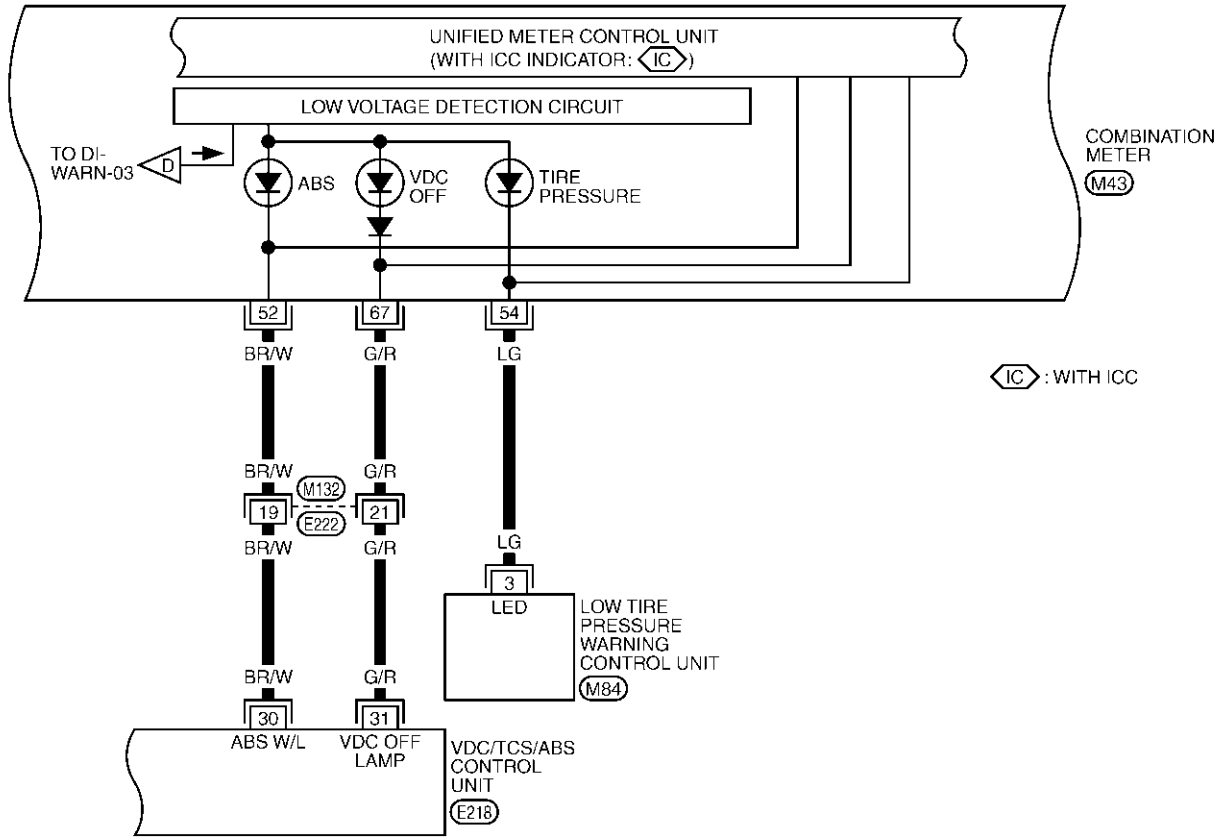

REFER TO THE FOLLOWING.
(E218) -ELECTRICAL UNITS

A
B
C
D
E
F
G
H
I
J
L
M

DI

WARNING LAMPS

DI-WARN-06

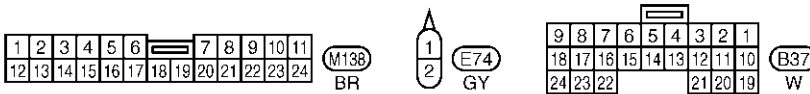
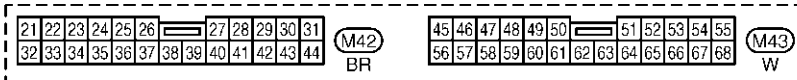
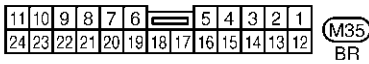
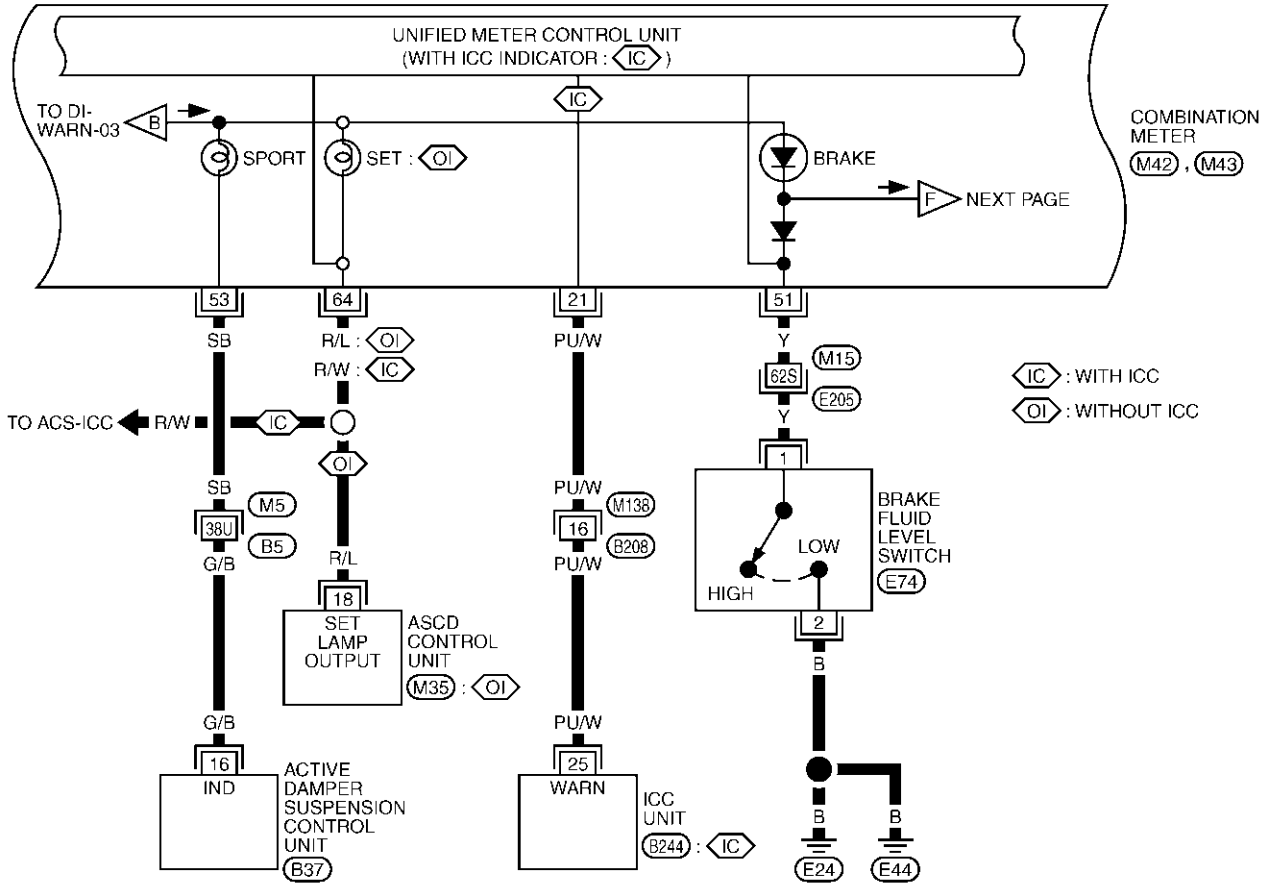

REFER TO THE FOLLOWING.

(M5), (E205) -SUPER MULTIPLE JUNCTION (SMJ)

(B244) -ELECTRICAL UNITS

TKWM0264E

WARNING LAMPS

DI-WARN-07

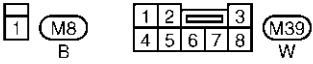
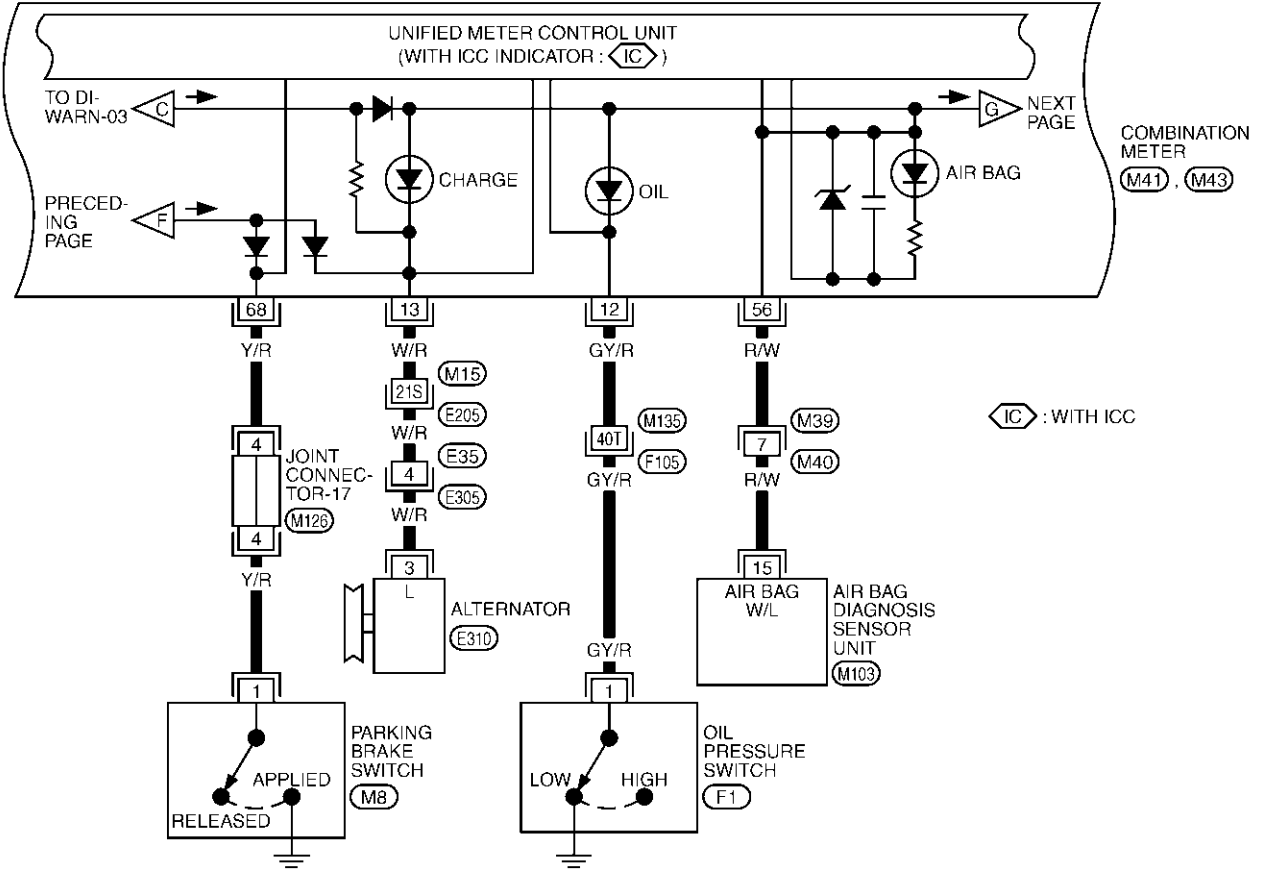

REFER TO THE FOLLOWING.
(E205), (F105) -SUPER MULTIPLE JUNCTION (SMJ)

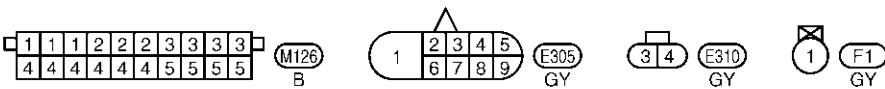
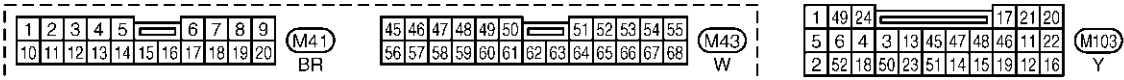

TKWM0265E

WARNING LAMPS

DI-WARN-08

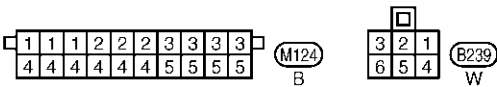
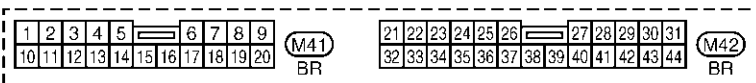
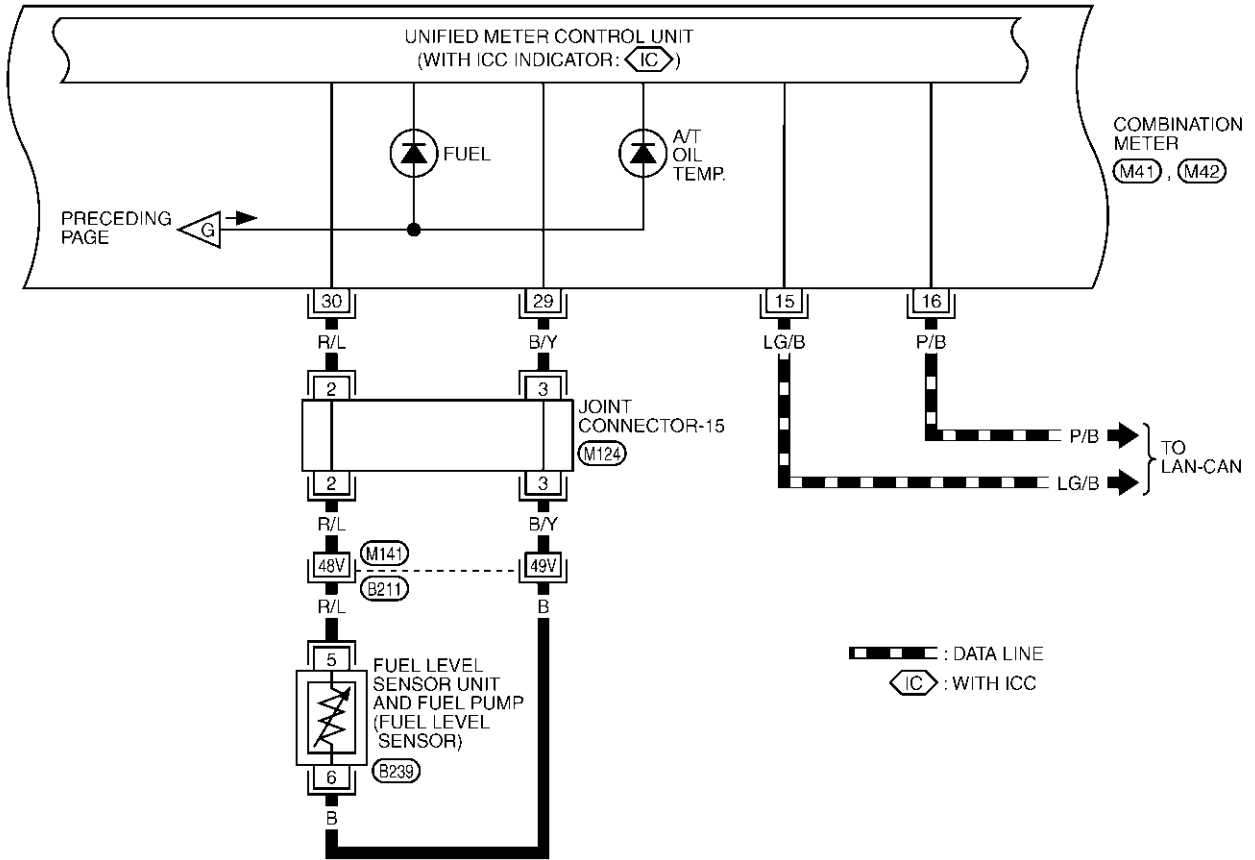

REFER TO THE FOLLOWING.
(B211) -SUPER MULTIPLE JUNCTION (SMJ)

TKWM0213E

WARNING LAMPS

DI-WARN-09

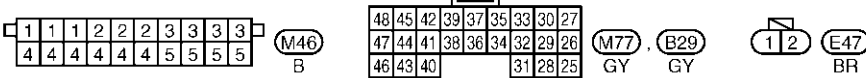
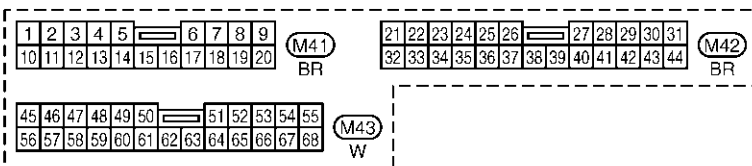
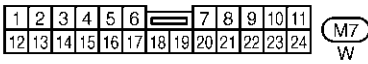
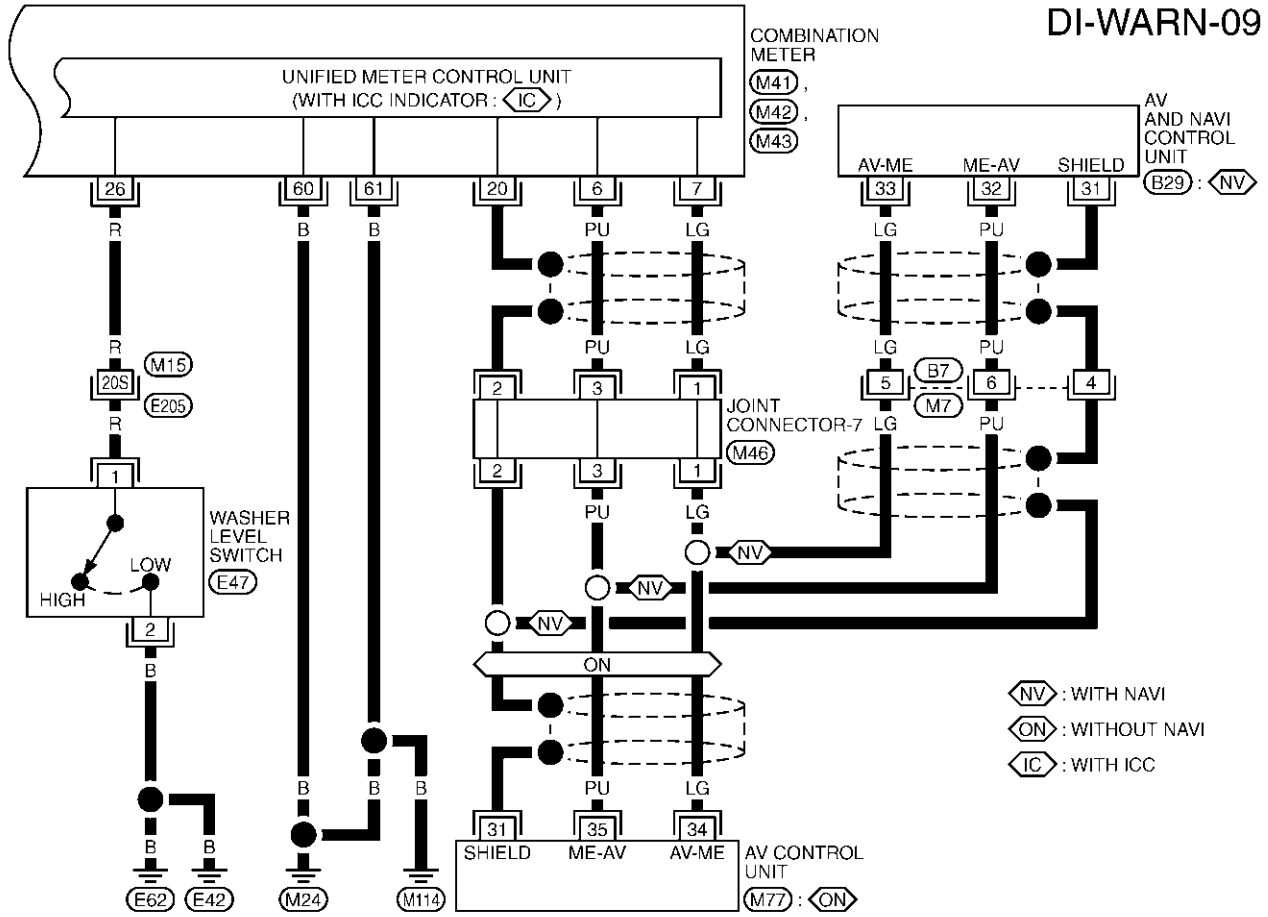

REFER TO THE FOLLOWING.

$\langle E205 \rangle$ -SUPER MULTIPLE JUNCTION (SMJ)

A
B
C
D
E
F
G
H
I
J
DI
L
M

TKWM0266E

WARNING LAMPS

Terminals and Reference Value for BCM

EKS0010L

Terminal No.	Wire color	Item	Condition		Reference value (V)
			Ignition switch	Operation	
2	L/W	Shift lock sol. signal	OFF	Depress brake pedal	Approx. 0
				Release brake pedal	Battery voltage
33	W	Rear door switch (LH)	OFF	Rear door switch LH	ON (open) Approx. 0
					OFF (closed) Battery voltage
37	W/G	Passenger door switch	OFF	Passenger door switch	ON (open) Approx. 0
					OFF (closed) Battery voltage
111	P/B	Door warning lamp	OFF	Door switch warning	ON (open) Approx. 0
					OFF (closed) Battery voltage
142	W/R	Driver door switch	OFF	Driver door switch	ON (open) Approx. 0
					OFF (closed) Battery voltage
143	W/L	Rear door switch (RH)	OFF	Rear door switch RH	ON (open) Approx. 0
					OFF (closed) Battery voltage

Work Flow

EKS001R1

1. Check the symptom and customer's requests.
2. Understand the outline of system. Refer to [DI-33, "System Description"](#).
3. Perform the preliminary inspection. Refer to [DI-64, "Preliminary Inspection"](#)
4. Referring to trouble diagnosis chart, repair or replace the cause of the malfunction. Refer to [DI-50, "Trouble Diagnosis for Door Warning Lamp"](#)
5. Does warning chime system operate normally? If it operates normally, GO TO step 6. If not, GO TO step 4.
6. Inspection END.

Preliminary Inspection

EKS001A0

Perform preliminary check, refer to [DI-64, "Preliminary Inspection"](#)

WARNING LAMPS

CONSULT-II Function

EKS006SP

- CONSULT-II executes the following functions by combining data reception and command transmission via the communication line from BCM. IVMS communication inspection, work support (only function setting of seats and steering wheel), self-diagnosis, data monitor, and active test display.

DIAGNOSTIC ITEMS DESCRIPTION

IVMS diagnosis position	Diagnosis mode	Description
DOOR OPEN WARNING	Data monitor	The input data to the BCM control unit is displayed in real time.
	Active test	Operation of electrical loads can be checked by sending driving signal to them.
BCM PART NUMBER		Displays BCM part No.

CONSULT-II BASIC OPERATION PROCEDURE

- With the ignition switch OFF, connect "CONSULT-II" and "CONSULT-II CONVERTER" to the data link connector, and turn the ignition switch ON.

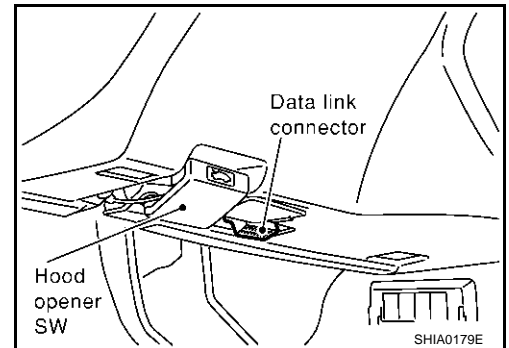

- Touch "START (NISSAN BASED VHCL)".

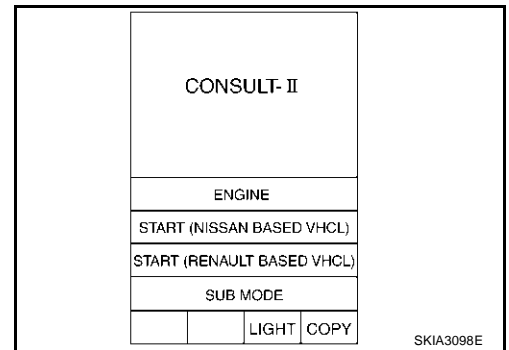

- Touch "IVMS".
If "IVMS" is not indicated, go to [GI-38, "CONSULT-II Data Link Connector \(DLC\) Circuit"](#).

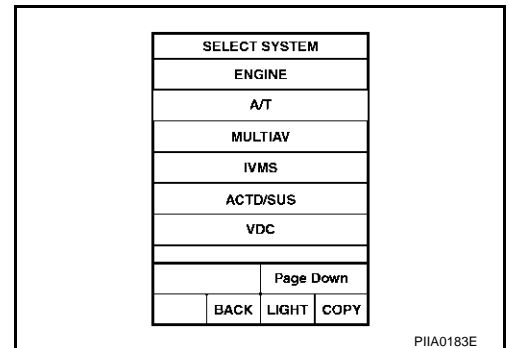

WARNING LAMPS

4. Check the model specification, touch either "WITH SUNROOF" or "WITHOUT SUNROOF".
5. Touch "OK". If the selection is wrong, touch "CANCEL".

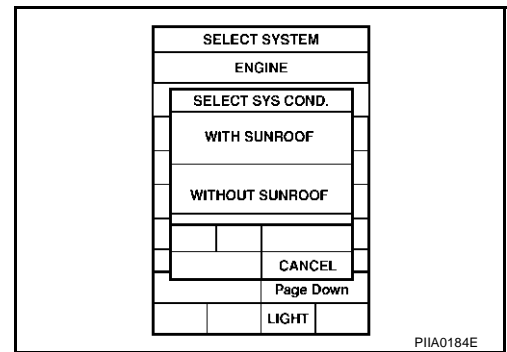

6. Select the desired part to be diagnosed on the "SELECT TEST ITEM" screen.

DATA MONITOR

Operation Procedure

1. Touch "DOOR OPEN WARNING" on "SELECT TEST ITEM" screen.
2. Touch "DATA MONITOR" on "SELECT DIAG MODE" screen.
3. Touch "MAIN SIGNALS" or "SELECTION FROM MENU" on "DATA MONITOR" screen.

MAIN SIGNALS	Monitors the main items.
SELECTION FROM MENU	Selects and monitors the items.

4. Touch "START".
5. If "SELECTION FROM MENU" is selected, touch the desired monitor item. If "MAIN SIGNALS" is selected, the main item required to control is monitored.
6. During monitoring, touching "COPY" can start recording the monitor item status.

Data Monitor Item

Monitored item	Description
IGN ON SW	Indicates [ON/OFF] condition of ignition switch.
DOOR SW-DR	Indicates [ON/OFF] condition of front door switch (driver side).
DOOR SW-AS	Indicates [ON/OFF] condition of front door switch (passenger side).
DOOR SW-RL	Indicates [ON/OFF] condition of door lock assembly rear LH (door switch).
DOOR SW-RR	Indicates [ON/OFF] condition of door lock assembly rear RH (door switch).

ACTIVE TEST

Operation Procedure

1. Touch "DOOR OPEN WARNING" on "SELECT TEST ITEM" screen.
2. Touch "ACTIVE TEST" on "SELECT DIAG MODE" screen.
3. Touch the item to be tested, and check the operation.
4. During the operation check, touching "OFF" deactivates the operation.

Active Test Item

Test item.	Malfunction detecting condition
DR OPN WARN LAMP	This test is able to check door warning lamp operation. Door warning lamp indicate when touch "ON" on CONSULT-II screen.

WARNING LAMPS

EKS001R4

On Board Diagnosis

ON BOARD DIAGNOSTIC RESULTS INDICATOR LAMP

- Map lamps and step lamps (all seats) act as the indicators for the on board diagnosis.

DIAGNOSIS ITEM

Diagnosis item	Description
Switch monitor	Monitoring conditions of switches connected to BCM.

SWITCH MONITOR

- Perform the diagnosis on the switch system to each control unit.

How to Perform Switch Monitor

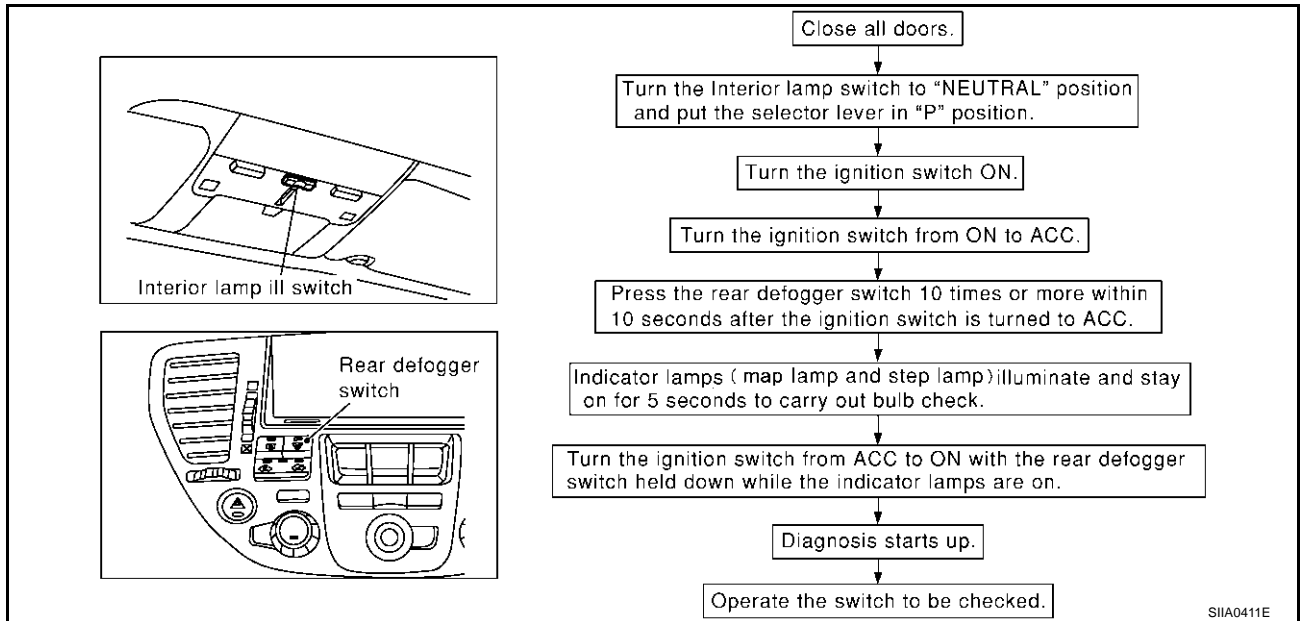

Description

- In this mode, when BCM detects the input signal from a switch in IVMS as shown below, the detection is indicated by the map lamp and front step lamps with buzzer.

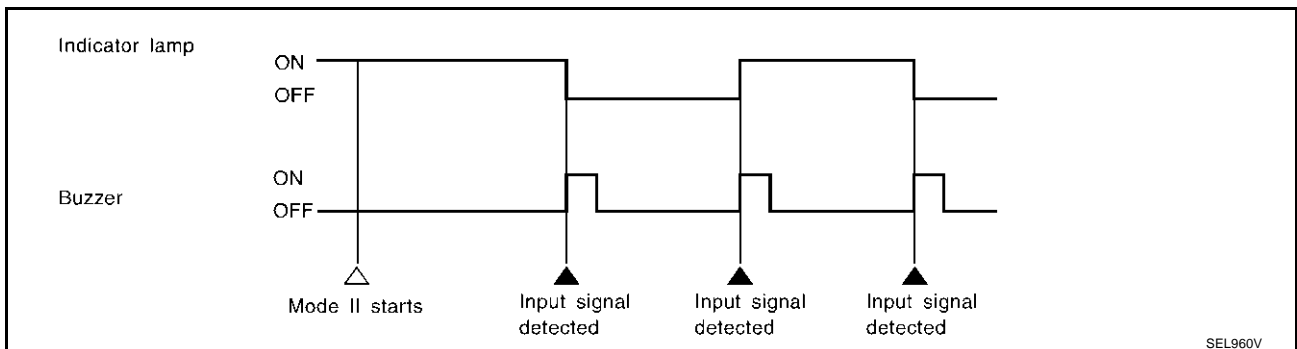

Switch Monitor Item

- The status of the switch (except the ignition switch, interior lamp switch, and map lamp switch) as input to each control unit can be monitored.

BCM	Front door switch (driver side)
	Front door switch (passenger side)
	Rear door switch LH
	Rear door switch RH

WARNING LAMPS

Cancel of Switch Monitor

- Turn ignition switch OFF.
- Drive the vehicle at more than 7 km/h (4 MPH).

Trouble Diagnosis for Door Warning Lamp

EKS0010Q

Symptom	Diagnostic procedure and repair order
Door warning lamp does not illuminate with any of doors open.	<ul style="list-style-type: none"> ● Check combination meter circuit. Refer to DI-50, "Combination Meter Circuit Inspection" . ● Check front door switch. Refer to DI-51, "Front Door Switch Inspection" . ● Check rear door switch. Refer to DI-52, "Rear Door Switch Inspection" . <p>If the above systems work properly, replace the BCM.</p>
Door warning lamp illuminates constantly.	<ul style="list-style-type: none"> ● Check combination meter circuit. Refer to DI-50, "Combination Meter Circuit Inspection" . ● Check front door switch. Refer to DI-51, "Front Door Switch Inspection" . ● Check rear door switch. Refer to DI-52, "Rear Door Switch Inspection" . <p>If the above systems work properly, replace the BCM.</p>

Combination Meter Circuit Inspection

EKS0010R

1. CHECK DOOR WARNING LAMP INPUT SIGNAL

1. Turn ignition switch OFF.
2. Disconnect BCM connector and combination meter connector.
3. Check the following.
 - Continuity between BCM harness connector M4 terminal 111 (P/B) and combination meter harness connector M43 terminal 49 (L/Y).

Continuity should exist.

- Continuity between BCM harness connector M4 terminal 111 (P/B) and ground.

Continuity should not exist.

OK or NG

- OK >> GO TO 2.
- NG >> Repair harness or connector.

2. CHECK DOOR WARNING LAMP

1. Connect combination meter connector.
2. Turn ignition switch ON.
3. Check voltage between BCM harness connector M4 terminal 111 (P/B) and ground.

Battery voltage should exist.

OK or NG

- OK >> Combination meter is OK.
- NG >> Replace combination meter.

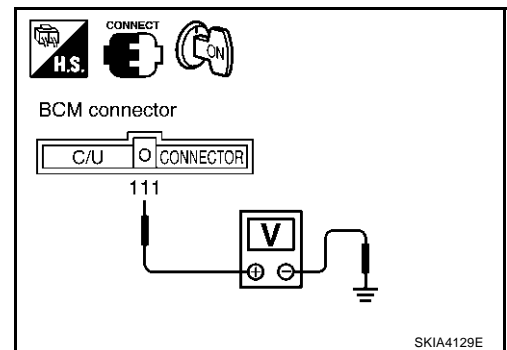
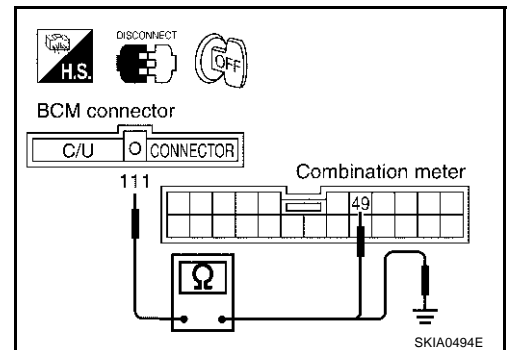

WARNING LAMPS

EKS0010S

Front Door Switch Inspection

1. CHECK FRONT DOOR SWITCH OPERATION

With CONSULT-II

- See "DOOR SW" on DATA MONITOR in DATA MONITOR mode.

Without CONSULT-II

- Check front door switches in switch monitor mode. Refer to [DI-49, "On Board Diagnosis"](#).

OK or NG

- OK >> Front door switch is OK.
- NG >> GO TO 2.

DATA MONITOR	
MONITOR	
DOOR SW-DR	OFF
DOOR SW-AS	OFF
DOOR SW-RR	OFF
DOOR SW-RL	OFF
RECORD	

SEL498W

2. CHECK FRONT DOOR SWITCH OPEN OR SHORT CIRCUIT

- Disconnect BCM connector and front door switches connector.
- Turn ignition switch OFF.
- Check the following.
 - Continuity between BCM harness connector B4 terminal 142 (W/R) and front door switch (driver side) harness connector B20 terminal 1 (W/R).

Continuity should exist.

- Continuity between BCM harness connector M4 terminals 37 (W/G) and front door switch (passenger side) harness connector B220 terminal 1 (W/G).

Continuity should exist.

- Continuity between BCM harness connectors M4, B4 terminals 37 (W/G), 142 (W/R) and ground.

Continuity should not exist.

OK or NG

- OK >> GO TO 3.
- NG >> Repair harness or connector.

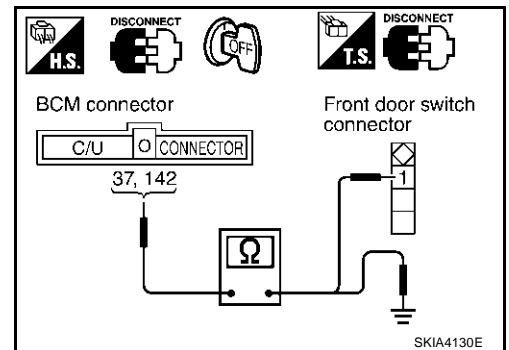

3. CHECK FRONT DOOR SWITCH (DRIVER SIDE OR PASSENGER SIDE)

Check continuity between front door switch harness connector B20 (driver side), B220 (passenger side) terminal 1 and ground.

Connector	Terminal		Condition	Continuity
Front door switch	1	Ground	Pressed	No
			Released	Yes

OK or NG

- OK >> Front door switch is OK.
- NG >> Replace front door switch (driver side) or (passenger side).

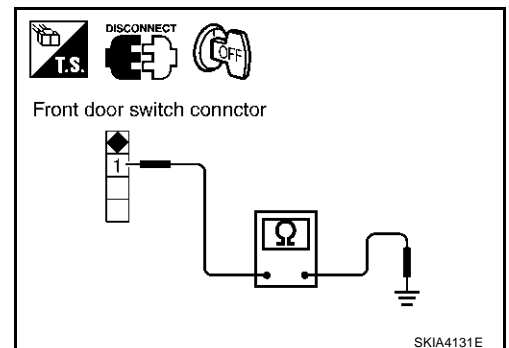

WARNING LAMPS

EKS0010T

Rear Door Switch Inspection

1. CHECK REAR DOOR SWITCH OPERATION

With CONSULT-II

- See "DOOR SW" in DATA MONITOR mode.

Without CONSULT-II

- Check rear door switches in switch monitor mode. Refer to [DI-49, "On Board Diagnosis"](#).

OK or NG

- OK >> Rear door switch is OK.
- NG >> GO TO 2.

DATA MONITOR	
MONITOR	
DOOR SW-DR	OFF
DOOR SW-AS	OFF
DOOR SW-RR	OFF
DOOR SW-RL	OFF
RECORD	

SEL498W

2. CHECK REAR DOOR SWITCH INPUT SIGNAL

1. Disconnect BCM connector and door lock assembly rear connector.
2. Turn ignition switch OFF.
3. Check the following.

- Continuity between BCM harness connector M4 terminal 33 (W) and door lock assembly rear LH (door switch) harness connector D62 terminal 1 (W).

Continuity should exist.

- Continuity between BCM harness connector B4 terminals 143 (W/L) and door lock assembly rear RH (door switch) harness connector D82 terminal 1 (W).

Continuity should exist.

- Continuity between BCM harness connector M4, B4 terminals 33 (W), 143 (W/L) and body ground.

Continuity should not exist.

OK or NG

- OK >> GO TO 3.
- NG >> Repair harness or connector.

3. CHECK REAR DOOR SWITCH

Check continuity between door lock assembly rear (door switch) harness connector D62 or D82 terminals 1 and 2.

Connector	Terminal		Condition	Continuity
	1	2		
Door lock assembly (door switch)	1	2	Pressed	No
			Released	Yes

OK or NG

- OK >> GO TO 4.
- NG >> Replace door lock assembly rear (door switch) LH or RH.

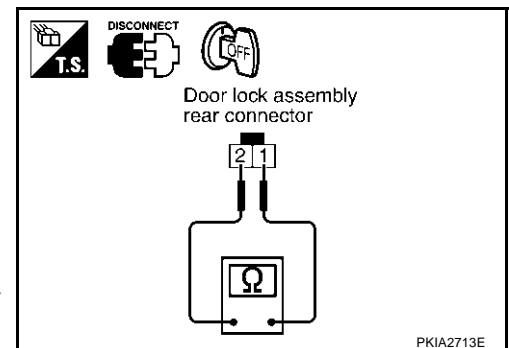
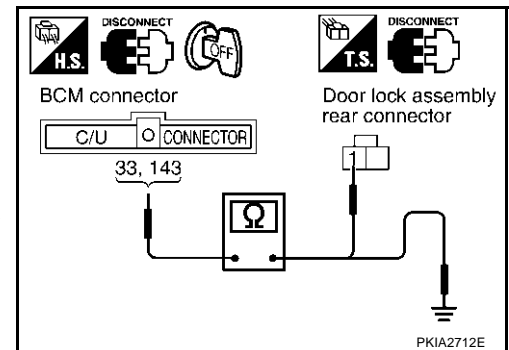

WARNING LAMPS

4. CHECK REAR DOOR SWITCH GROUND CIRCUIT

Check continuity between door lock assembly rear (door switch) harness connector D62 or D82 terminal 2 (B) and ground.

Continuity should exist.

OK or NG

- OK >> Inspection end.
- NG >> Repair harness or connector.

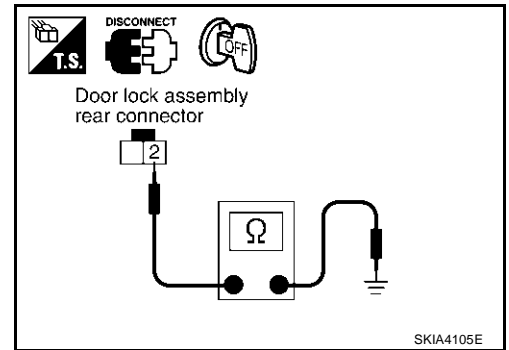

EKS0010U

Electrical Components Inspection OIL PRESSURE SWITCH

Check continuity between the oil pressure switch and ground.

Condition	Oil pressure MPa (kg/cm ² , psi)	Continuity
Engine not running	Less than 0.02 - 0.029 (0.2-0.3, 3-4)	Yes
Engine running	More than 0.02 - 0.029 (0.2-0.3, 3-4)	No

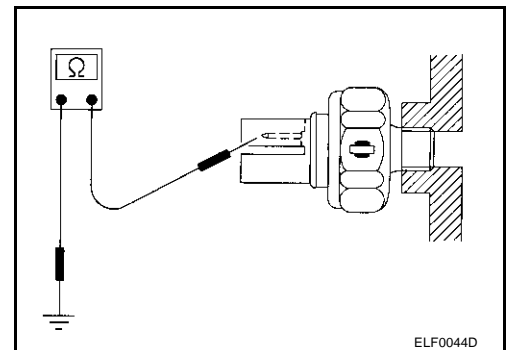

ELF0044D

DIODE CHECK

- Check continuity using an ohmmeter.
- Diode is functioning properly if test results are as shown in the figure.
- Check diodes at the combination meter harness connector instead of on the combination meter assembly. Refer to [DI-37](#), "[Wiring Diagram — WARN —](#)".

NOTE:

Specification may vary depending on the type of tester. Before performing this inspection, be sure to refer to the instruction manual for the tester to be used.

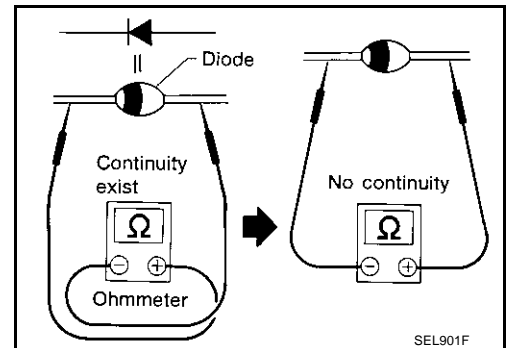

SEL901F

A/T INDICATOR

PFP:24814

A/T INDICATOR

Wiring Diagram — AT/IND —

EKS0017M

DI-AT/IND-01

▬ : DATA LINE

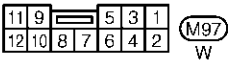
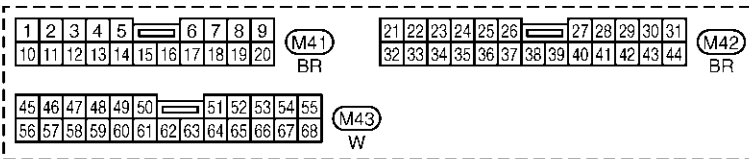
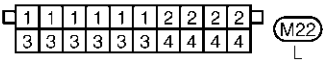
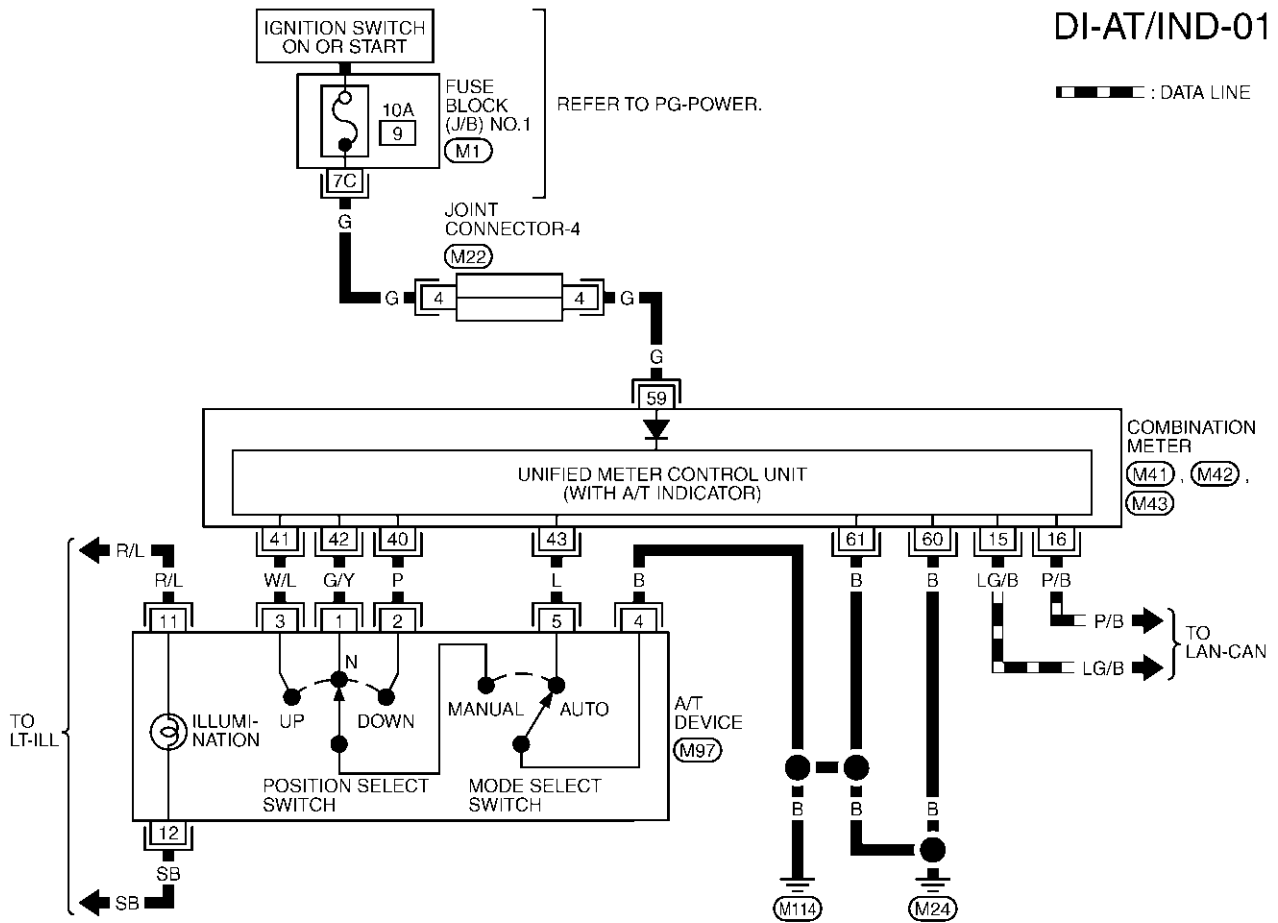

REFER TO THE FOLLOWING.

(M1) - FUSE BLOCK-JUNCTION BOX (J/B) NO.1

TKWM0425E

A/T INDICATOR

A/T Indicator Does Not Illuminate

EKS001BW

1. PERFORM SELF-DIAGNOSIS INSPECTION

Perform combination meter self-diagnosis mode. Refer to [DI-18, "Meter/Gauges Operation, Odo/Trip Meter, A/T Indicator and ICC System Display"](#).

OK or NG

OK >> GO TO 2.

NG >> Replace unified meter control unit (main and sub) and meter and gauge assembly.

2. CHECK TCM CONTROL UNIT SYSTEM

Perform TCM self-diagnosis. Refer to [AT-86, "CONSULT-II"](#) in AT section.

OK or NG

OK >> Replace unified meter control unit (main and sub) and meter and gauge assembly.

NG >> Perform "Diagnosis Procedure" for displayed DTC.

A

B

C

D

E

F

G

H

I

J

DI

L

M

WARNING CHIME

WARNING CHIME

PFP:24814

System Description FUNCTION

EKS0010V

Item	Description
Ignition key warning chime	Sounds warning chime when driver's door is opened with key in ignition key cylinder and ignition switch "OFF" or "ACC" position.
Light warning chime	Sounds warning chime when driver's door is opened with lighting switch in the 1st or 2nd position and ignition switch "OFF" or "ACC" position.
Seat belt warning chime	Sounds warning chime for about 6 seconds if ignition switch is turned "ON" when driver's seat belt is unfastened.

Power is supplied at all times

- through 10A fuse [No. 3, located in the fuse block (J/B) No. 1]
- to BCM terminal 105,
- through 10A fuse [No. 6, located in the fuse block (J/B) No. 1]
- to headlamp battery saver control unit terminal 7 and
- to warning chime terminal 1,
- through warning chime terminal 3
- to BCM terminal 12,
- through 10A fuse [No. 8, located in the fuse block (J/B) No. 1]
- to key switch and key lock solenoid (key switch) terminal 3, and
- through 15A fuse [No. 54, located in the fuse, fusible link and relay block (J/B)]
- to tail lamp relay terminals 2 and 6 [located in fuse, fusible link and relay block (J/B)].

With ignition switch in ON or START position, power is supplied

- through 10A fuse [No. 1, located in the fuse block (J/B) No. 1]
- to BCM terminal 68.

Ground is supplied

- to BCM terminals 56 and 113
- through grounds M24 and M114.

IGNITION KEY WARNING CHIME

With ignition switch in OFF or ACC position, and the driver's door open, the warning chime will sound. Power is supplied

- through key switch and key lock solenoid (key switch) terminal 4
- to BCM terminal 69, and

Ground is supplied

- to BCM terminal 142
- through front door switch (driver side) terminal 1.

Front door switch (driver side) is case ground.

LIGHT WARNING CHIME

With ignition switch OFF or ACC position, driver's door open, and lighting switch in 1ST or 2ND position, warning chime will sound. [Except when headlamp battery saver control operates (for 45 seconds after ignition switch is turned to OFF or ACC position) and headlamps do not illuminate.] Power is supplied

- from tail lamp relay [located in fuse, fusible link and relay block (J/B)] terminal 12R
- to BCM terminal 3,

Ground is supplied

- from door switch (driver side) terminal 1
- to BCM terminal 142.

Front door switch (driver side) is case ground.

WARNING CHIME

SEAT BELT WARNING CHIME

With ignition switch turned ON and seat belt unfastened (seat belt switch ON), warning chime will sound for approximately 6 seconds.

Ground is supplied

- from seat belt buckle switch terminal 41
- to BCM terminal 147

Seat belt terminal 15A is grounded through grounds B17 and B57.

Component Parts and Harness Connector Location

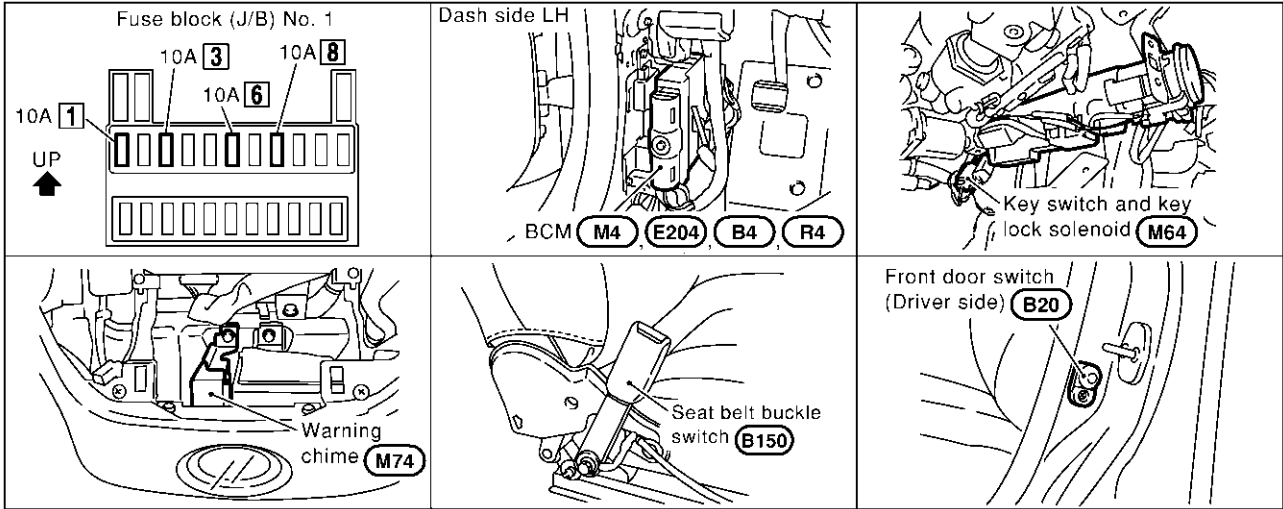

EKS0010W

SKIA0502E

Major Component Parts and Function

EKS0010X

Components	Functions
BCM	It operates the warning chime intermittently by signals from the ignition switch, key-in detection switch, lighting switch, or front door switch (driver side) or seat belt buckle switch (driver side).
Warning chime	It generates intermittent sounds by signals from the BCM.

A
B
C
D
E
F
G
H
I
J
DI
L
M

WARNING CHIME

Schematic

EKS0019J

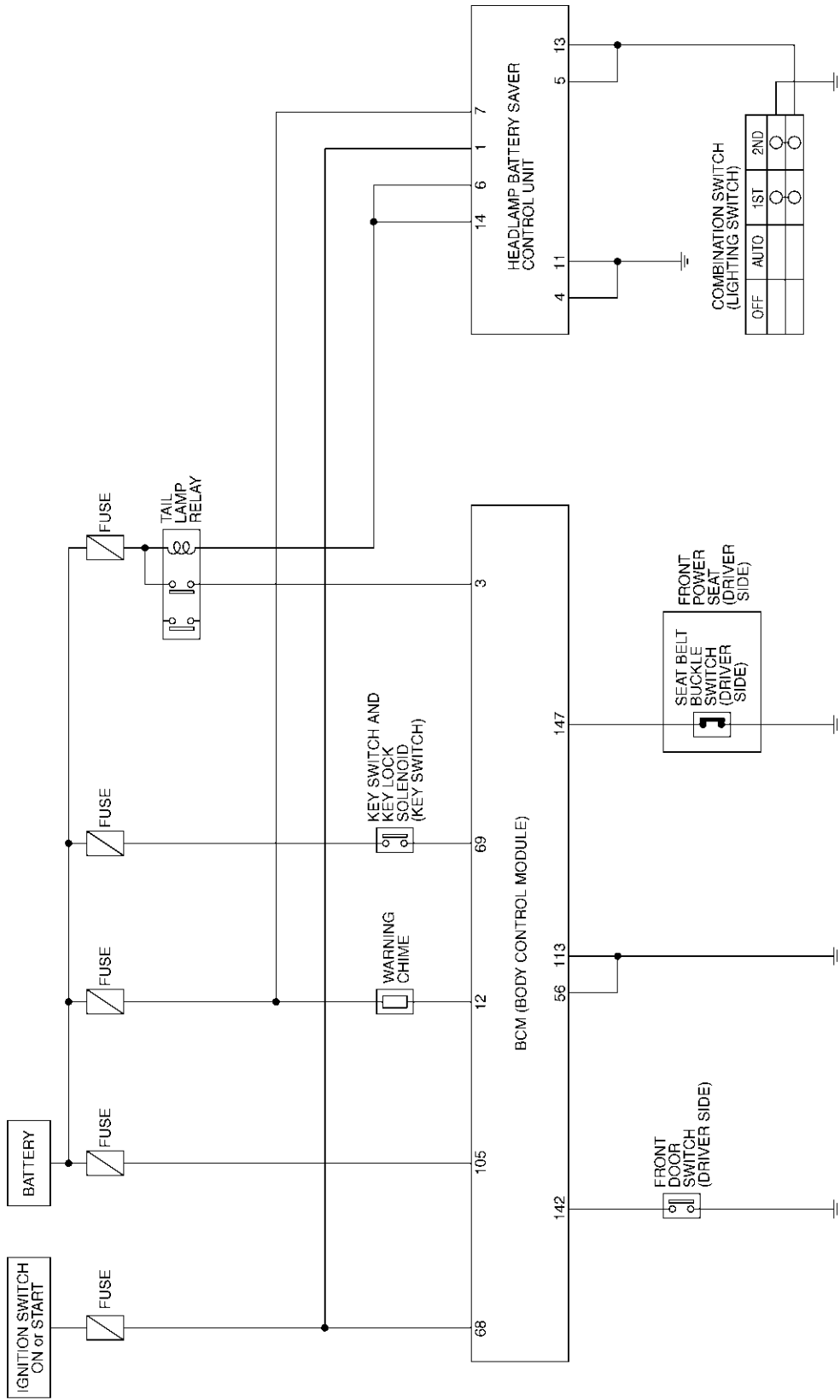

TKWM0533E

WARNING CHIME

Wiring Diagram — CHIME —

EKS0019K

DI-CHIME-01

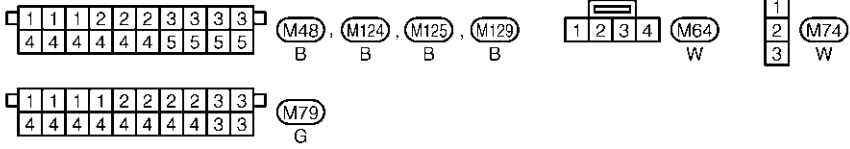
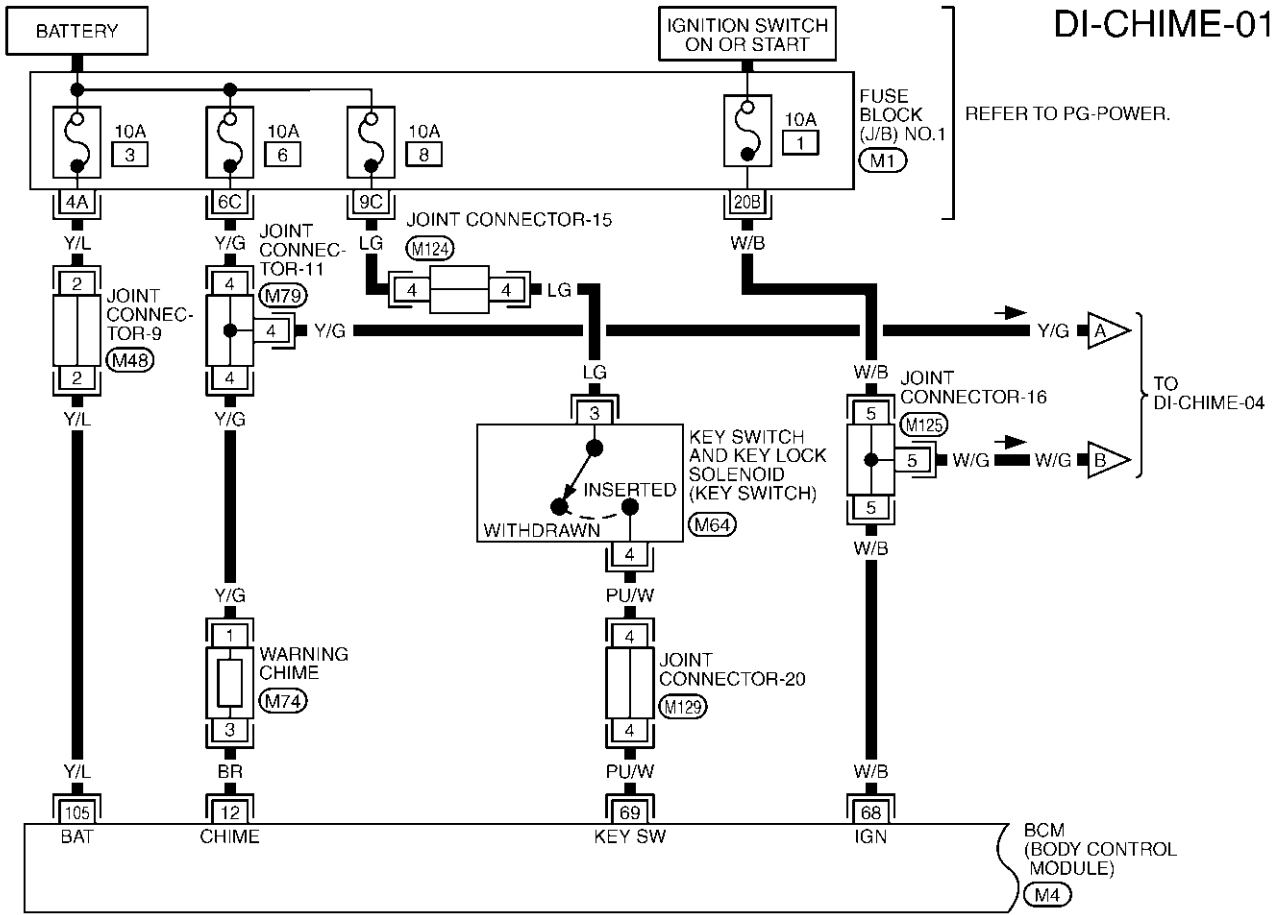

REFER TO THE FOLLOWING.

(M1) - FUSE BLOCK-JUNCTION BOX (J/B) NO.1

(M4) - ELECTRICAL UNITS

A
B
C
D
E
F
G
H
I
J
DI
L
M

WARNING CHIME

DI-CHIME-02

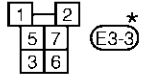
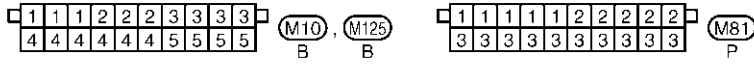
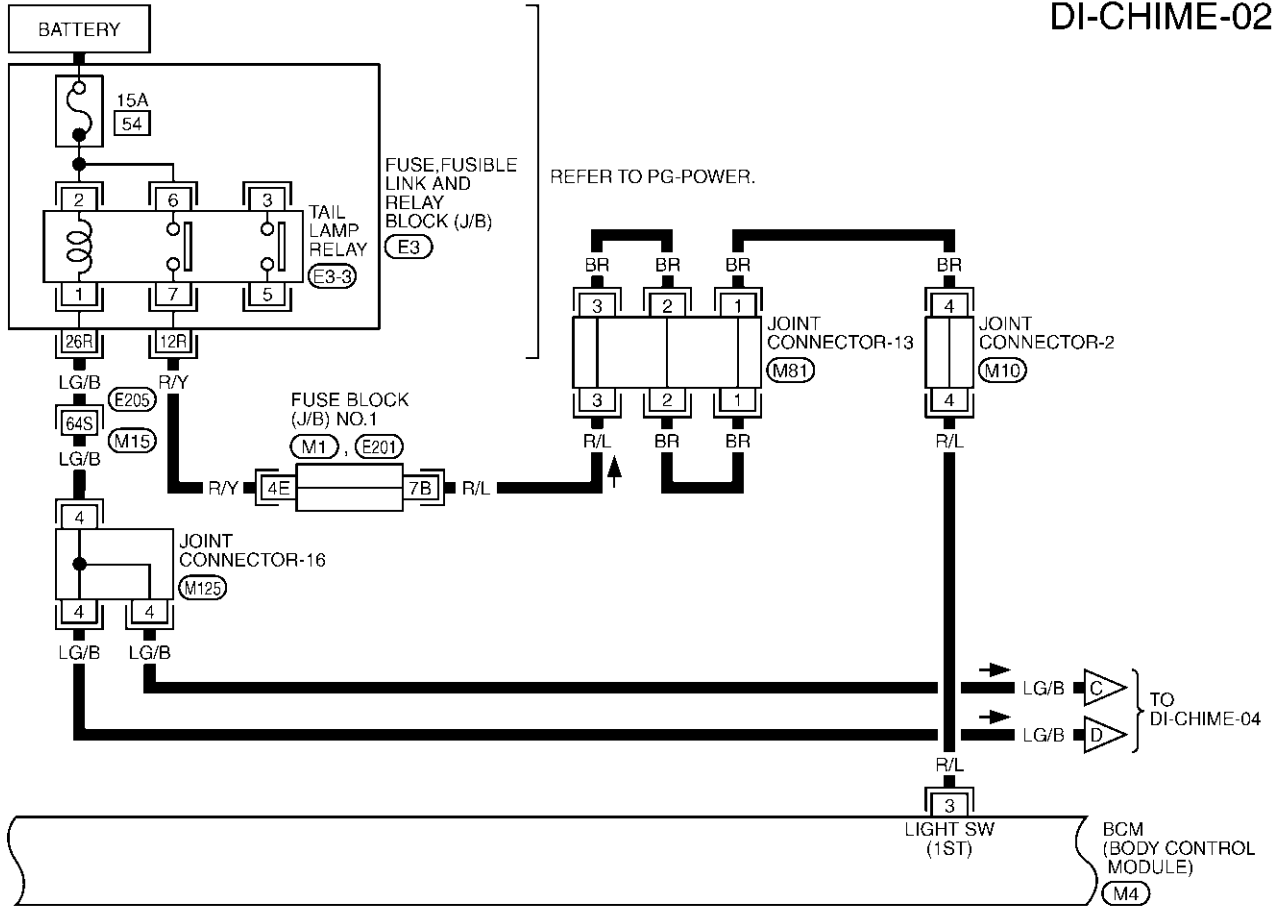

REFER TO THE FOLLOWING.

- (E205) -SUPER MULTIPLE JUNCTION (SMJ)
- (M1), (E201) -FUSE BLOCK-JUNCTION BOX (J/B) NO.1
- (E3) -FUSE,FUSIBLE LINK AND RELAY BLOCK (J/B)
- (M4) -ELECTRICAL UNITS

*: THIS CONNECTOR IS NOT SHOWN IN "HARNESS LAYOUT", PG SECTION.

TKWM0534E

WARNING CHIME

DI-CHIME-03

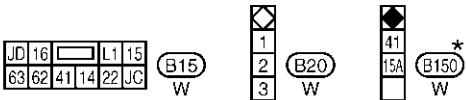
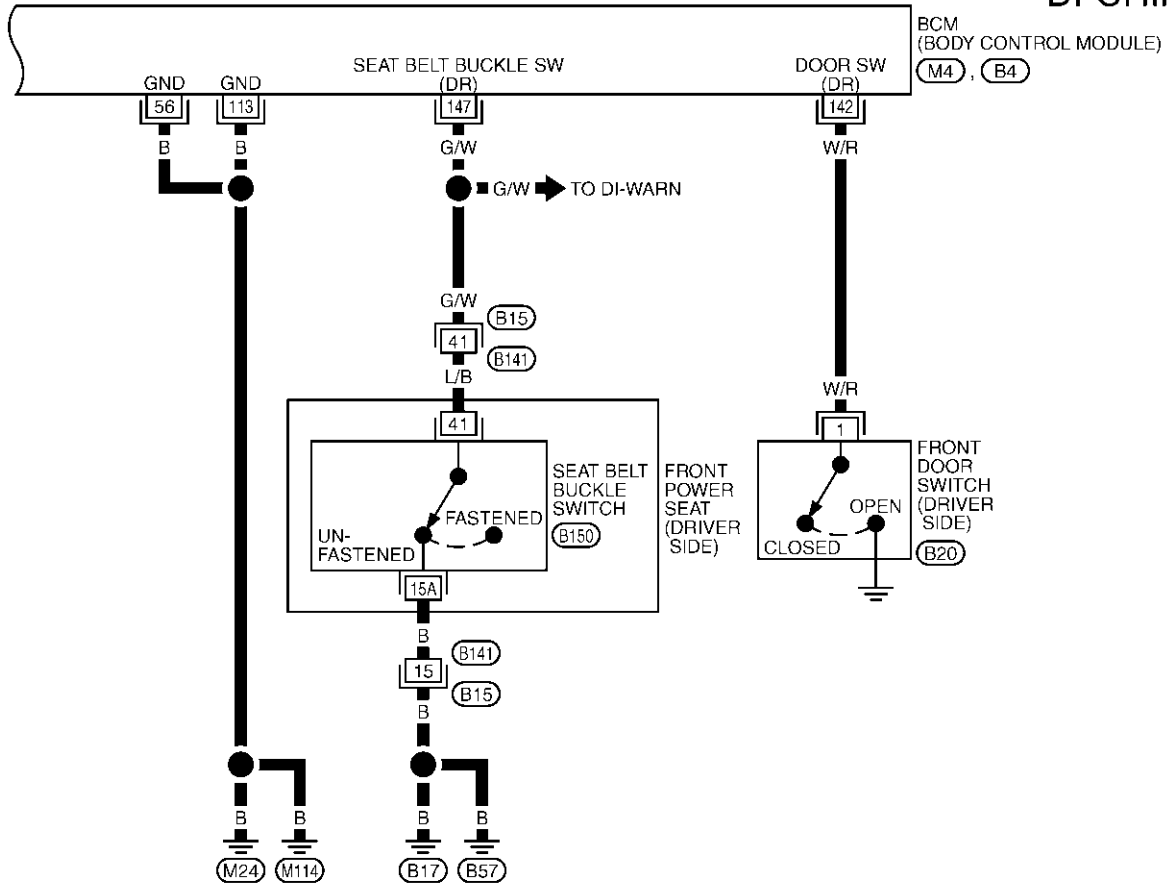

REFER TO THE FOLLOWING.
(M4), (B4) -ELECTRICAL UNITS

*: THIS CONNECTOR IS NOT SHOWN IN "HARNESS LAYOUT", PG SECTION.

TKWM0426E

WARNING CHIME

DI-CHIME-04

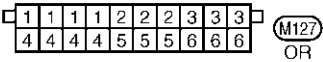
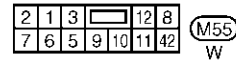
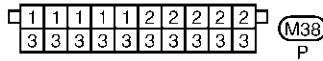
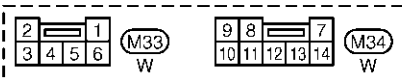
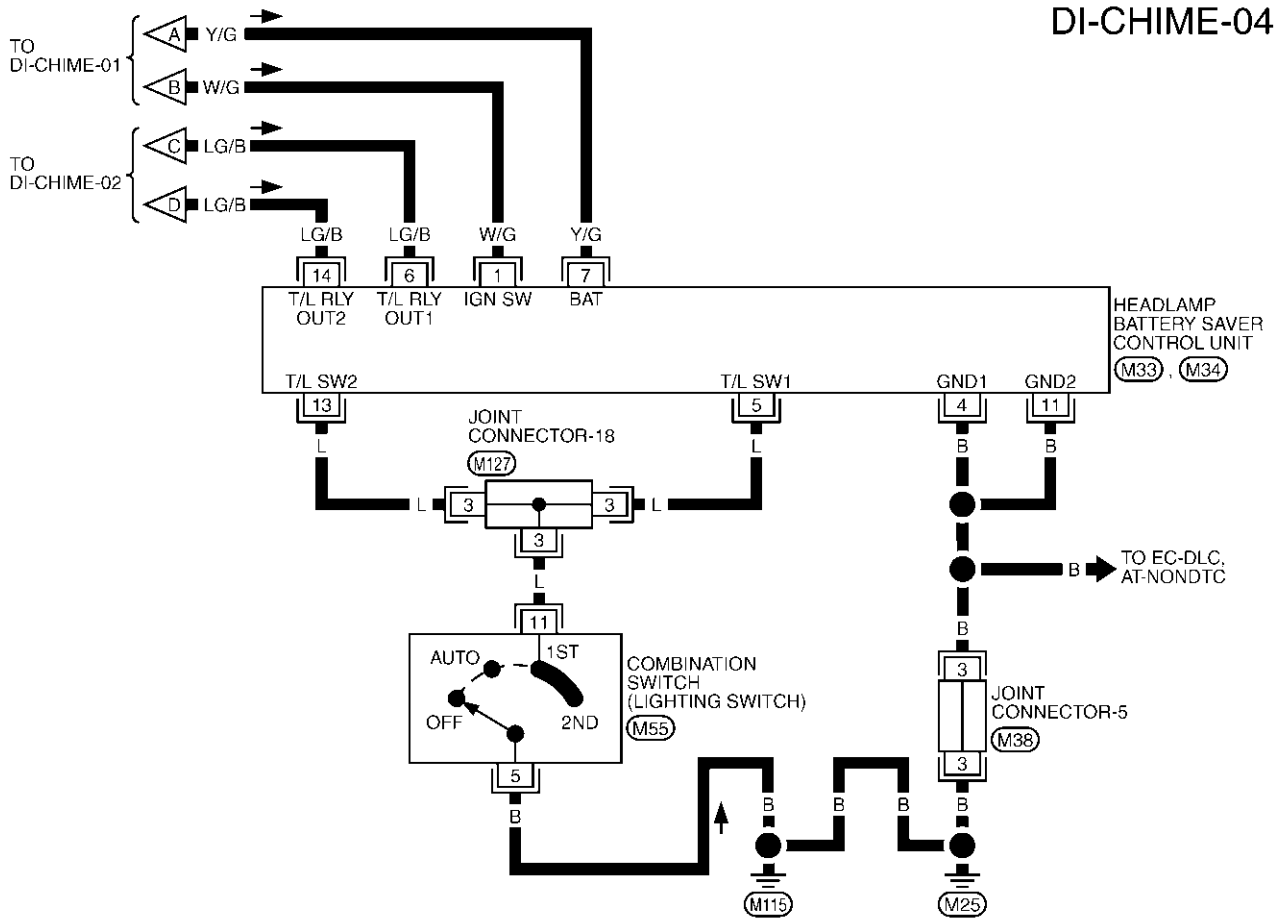

TKWM0427E

WARNING CHIME

Terminals and Reference Value Chart for BCM

EKS0010Z

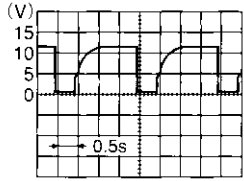
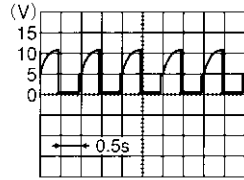
Terminal No.	Wire color	Item	Condition		Reference value
3	R/L	Tail lamp relay	Lighting switch, Position: 1ST, 2ND	ON	Battery voltage
				OFF	Approx. 0V
12	BR	Warning chime input signal	(Ignition key warning chime) Front door (driver side): OPEN Lighting switch: OFF	Key is inserted.	
				Key is removed.	Battery voltage
			(Light warning chime) Lighting switch, Position 1ST, 2ND	Front door (driver side): Open	
				Front door (driver side): Closed	Battery voltage
56	B	Ground	—		Approx. 0V
68	W/B	Ignition switch (ON)	Ignition switch is in "ON" position.		Battery voltage
69	PU/W	Key switch and key lock solenoid (key switch)	Key is removed (key switch: OFF).		Approx. 0V
			Key is inserted (key switch: ON).		Battery voltage
105	Y/L	Power source (BAT)	—		Battery voltage
113	B	Ground	—		Approx. 0V
142	W/R	Front door switch (driver side)	ON (Open)		Approx. 0V
			OFF (Closed)		Battery voltage
147	G/W	Seat belt buckle switch (driver side)	Ignition switch is "ON" position.	Fasten	Approx. 5V
				Unfasten	Approx. 0V

Work Flow

EKS0010X

1. Check the symptom and customer's requests.
2. Understand the outline of system. Refer to [DI-56, "System Description"](#).
3. Perform the preliminary check. Refer to [DI-64, "Preliminary Inspection"](#).
4. Referring to trouble diagnosis chart, repair or replace the cause of the malfunction. Refer to [DI-68, "Symptom Chart"](#).
5. Does warning chime system operate normally? If it operates normally, GO TO step 6. If not, GO TO step 4.
6. Inspection END.

WARNING CHIME

EKS001QY

Preliminary Inspection INSPECTION FOR POWER SUPPLY AND GROUND CIRCUIT

1. CHECK FUSES

Check that any of the following fuses for the BCM is blown.

Unit	Power source	Fuse No.
BCM	Battery	3
	Ignition switch (ON)	1
Warning chime	Battery	6

Refer to [DI-59, "Wiring Diagram — CHIME —"](#).

OK or NG

OK >> GO TO 2.

NG >> If fuse is blown, be sure to eliminate cause of malfunction before installing new fuse. Refer to [PG-2, "POWER SUPPLY ROUTING"](#).

2. CHECK POWER SUPPLY CIRCUIT

1. Disconnect BCM connector.
2. Check voltage between BCM connector M4 terminal 68 (W/B), 105 (Y/L) and ground.

Terminals			Ignition switch position		
(+)			OFF	ACC	ON
Connector	Terminal (Wire color)	(-)			
M4	68 (W/B)	Ground	0V	0V	Battery voltage
M4	105 (Y/L)	Ground	Battery voltage	Battery voltage	Battery voltage

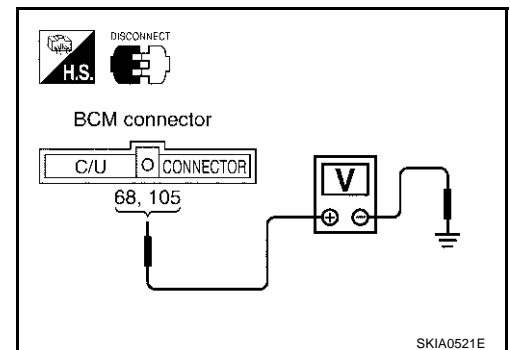

OK or NG

OK >> GO TO 3.

NG >> Check harness for open or short between BCM and fuse.

3. CHECK GROUND CIRCUIT

Check continuity between BCM harness connector M4 terminals 56 (B), 113 (B) and ground.

Continuity should exist.

OK or NG

OK >> Inspection end.

NG >> Repair harness.

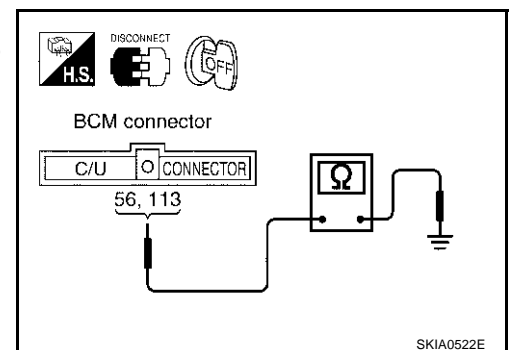

WARNING CHIME

EKS001QZ

CONSULT-II Function

- CONSULT-II executes the following functions by combining data reception and command transmission via the communication line from BCM. IVMS communication inspection, work support (only function setting of seats and steering wheel), self-diagnosis, data monitor, and active test display.

DIAGNOSTIC ITEMS DESCRIPTION

IVMS diagnosis position	Diagnosis mode	Description
IGN KEY WARN ALM	Data monitor	The input data to the BCM control unit is displayed in real time.
	Active test	Operation of electrical loads can be checked by sending driving signal to them.
LIGHT WARN ALM	Data monitor	The input data to the BCM control unit is displayed in real time.
	Active test	Operation of electrical loads can be checked by sending driving signal to them.
SEAT BELT TIMER	Data monitor	The input data to the BCM control unit is displayed in real time.
	Active test	Operation of electrical loads can be checked by sending driving signal to them.
BCM PART NUMBER		Displays BCM part No.

CONSULT-II BASIC OPERATION PROCEDURE

- With the ignition switch OFF, connect "CONSULT-II" and "CONSULT-II CONVERTER" to the data link connector, and turn the ignition switch ON.

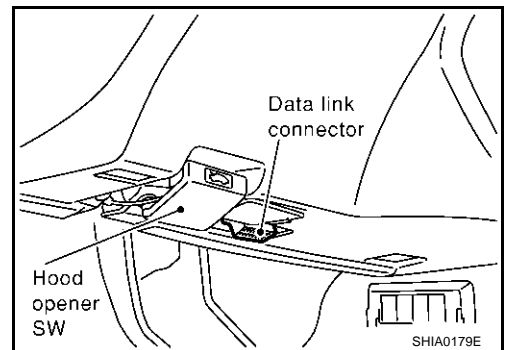

- Touch "START (NISSAN BASED VHCL)".

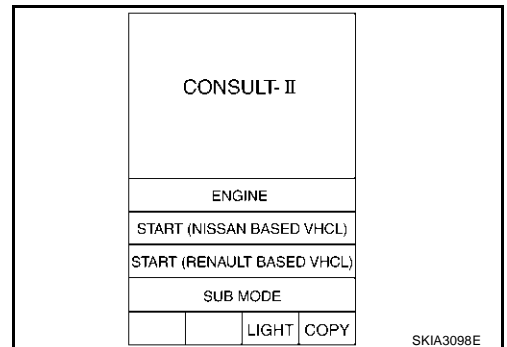

- Touch "IVMS".
If "IVMS" is not indicated, go to [GI-38, "CONSULT-II Data Link Connector \(DLC\) Circuit"](#).

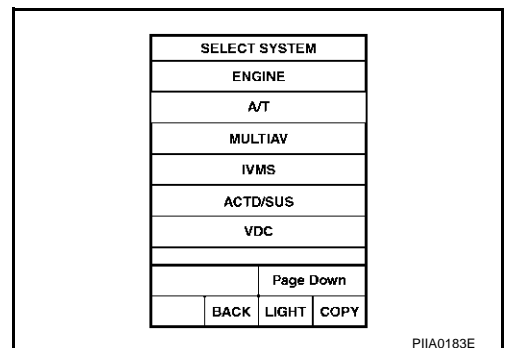

WARNING CHIME

4. Check the model specification, touch either "WITH SUNROOF" or "WITHOUT SUNROOF".
5. Touch "OK". If the selection is wrong, touch "CANCEL".

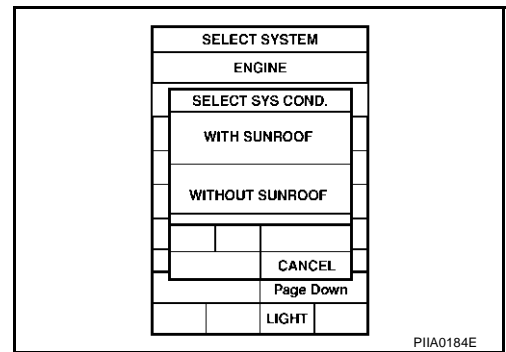

6. Select the desired part to be diagnosed on the "SELECT TEST ITEM" screen.

DATA MONITOR

Operation Procedure

1. Touch "IGN WARN ALM", "LIGHT WARN ALM" or "SEAT BELT WARM" on "SELECT TEST ITEM" screen.
2. Touch "DATA MONITOR" on "SELECT DIAG MODE" screen.
3. Touch "MAIN SIGNALS" or "SELECTION FROM MENU" on "DATA MONITOR" screen.

MAIN SIGNALS	Monitors the main items.
SELECTION FROM MENU	Selects and monitors the items.

4. Touch "START".
5. If "SELECTION FROM MENU" is selected, touch the desired monitor item. If "MAIN SIGNALS" is selected, the main item required to control is monitored.
6. During monitoring, touching "COPY" can start recording the monitor item status.

Data Monitor Item (Key Warning Chime)

Monitored item	Description
IGN KEY SW	Indicates [ON/OFF] condition of electronic key switch.
IGN ON SW	Indicates [ON/OFF] condition of ignition switch.
DOOR SW-DR	Indicates [ON/OFF] condition of front door switch LH.

Data Monitor Item (Light Warning Chime)

Monitored item	Description
IGN ON SW	Indicates [ON/OFF] condition of ignition switch.
DOOR SW-DR	Indicates [ON/OFF] condition of front door switch LH.
HD/LAMP 1ST SW	Indicates [ON/OFF] condition of lighting switch.

Data Monitor Item (Seat Belt Warning Chime)

Monitored item	Description
IGN ON SW	Indicates [ON/OFF] condition of ignition switch.
SEAT BELT SW	Indicates [ON/OFF] condition of fastening belt buckle switch.

ACTIVE TEST

Operation Procedure

1. Touch "IGN WARN ALM", "LIGHT WARN ALM" or "SEAT BELT WARM" on "SELECT TEST ITEM" screen.
2. Touch "ACTIVE TEST" on "SELECT DIAG MODE" screen.
3. Touch the item to be tested, and check the operation.
4. During the operation check, touching "OFF" deactivates the operation.

WARNING CHIME

Active Test Item (Key Warning Chime)

Test item	Malfunction detecting condition
CHIME	This test is able to check key warning chime operation. Key warning chime sounds for 2 seconds after touching "ON" on CONSULT-II screen.

Active Test Item (Light Warning Chime)

Test item	Malfunction detecting condition
CHIME	This test is able to check light warning chime operation. Light warning chime sounds for 2 seconds after touching "ON" on CONSULT-II screen.

Active Test Item (Seat Belt Warning Chime)

Test item	Malfunction detecting condition
CHIME	This test is able to check seat belt warning chime operation. Seat belt warning chime sounds for 2 seconds after touching "ON" on CONSULT-II screen.

On Board Diagnosis

EKS001R0

ON BOARD DIAGNOSTIC RESULTS INDICATOR LAMP

- Map lamps and step lamps (all seats) act as the indicators for the on board diagnosis.

DIAGNOSIS ITEM

Diagnosis item	Description
Switch monitor	Monitoring conditions of switches connected to BCM.

SWITCH MONITOR

- Perform the diagnosis on the switch system to each control unit.

How to Perform Switch Monitor

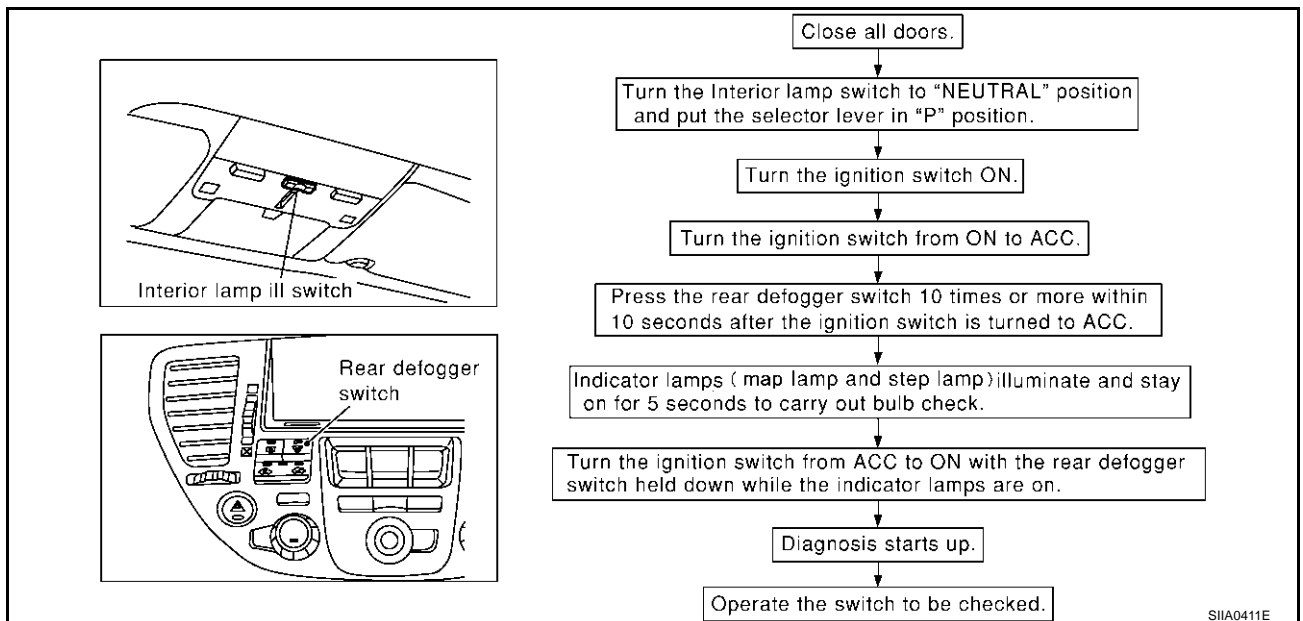

WARNING CHIME

Description

- In this mode, when BCM detects the input signal from a switch in IVMS as shown below, the detection is indicated by the map lamp and front step lamps with buzzer.

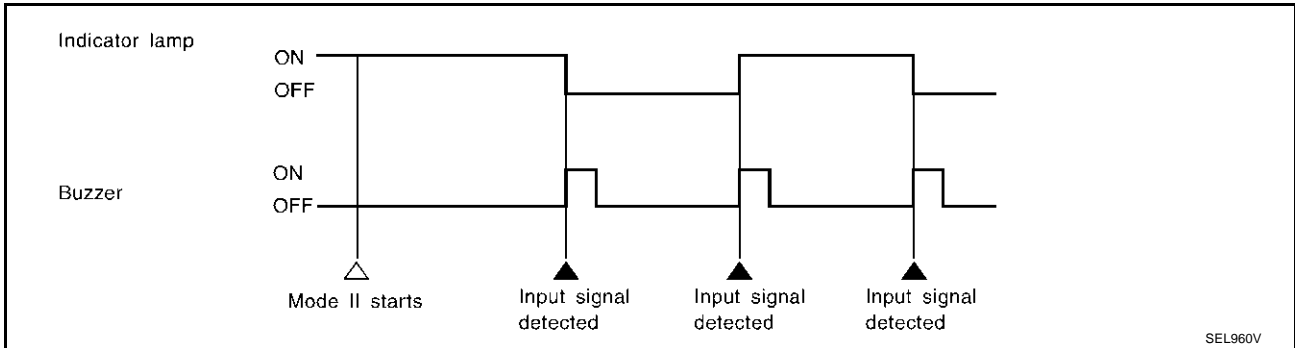

Switch Monitor Item

- The status of the switch (except the ignition switch, interior lamp switch, and map lamp switch) as input to each control unit can be monitored.

BCM	Driver door switch
	Lighting switch (1ST)
	Seat belt buckle switch

Cancel of Switch Monitor

- Turn ignition switch OFF
- Drive the vehicle at more than 7 km/h (4MPH).

Symptom Chart

EKS00114

Symptom	Possible cause and repair order
All warning chime does not activate.	<ul style="list-style-type: none"> Warning chime circuit check. Refer to DI-69, "Warning Chime Circuit Check" If the above systems are work properly, replace the BCM.
Light warning chime does not activate (headlamp system is properly).	<ul style="list-style-type: none"> Lighting switch input signal check. Refer to DI-73, "Lighting Switch Input Signal Inspection" Front door switch (driver side) check. Refer to DI-71, "Front Door Switch (Driver side) Inspection" . If the above systems are work properly, replace the BCM.
Key warning chime does not activate.	<ul style="list-style-type: none"> Key switch insert signal check. Refer to DI-72, "Key Switch Insert Signal Inspection" . Front door switch (driver side) check. Refer to DI-71, "Front Door Switch (Driver side) Inspection" . If the above systems are work properly, replace the BCM.
Seat belt warning chime does not activate.	<ul style="list-style-type: none"> Check seat belt buckle switch input signal check. Refer to DI-74, "Seat Belt Buckle Switch Inspection" If the above systems are work properly, replace the BCM.
With the ignition switch turned OFF and the door closed (driver side), turning the lighting switch ON (1st) activates the chime.	<ul style="list-style-type: none"> Door switch (driver side) check. Refer to DI-71, "Front Door Switch (Driver side) Inspection" . If the above systems are work properly, replace the BCM.

WARNING CHIME

EKS00115

Warning Chime Circuit Check

1. CHECK FUSES

Check 10A fuse [No. 6 located in fuse block (J/B) No. 1]

OK or NG

- OK >> GO TO 2.
- NG >> Replace the fuse.

2. CHECK POWER SUPPLY CIRCUIT

1. Turn ignition switch OFF.
2. Disconnect warning chime connector.
3. Check voltage between warning chime harness connector M74 terminal 1 (Y/G) and ground.

Battery voltage should exist.

OK or NG

- OK >> GO TO 3.
- NG >> Check harness for open or short between fuse and warning chime.

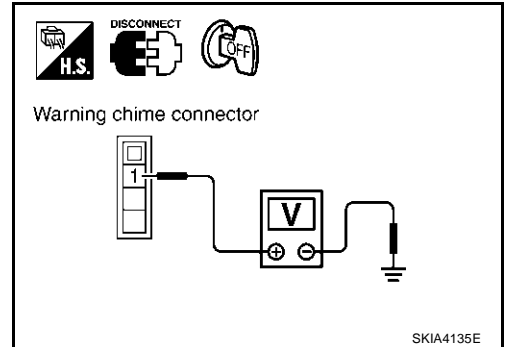

3. CHECK WARNING CHIME SHORT CIRCUIT

1. Disconnect BCM connector.
2. Check continuity between warning chime harness connector M74 terminal 3 (BR) and ground.

Continuity should not exist.

OK or NG

- OK >> GO TO 4.
- NO >> Repair harness or connector.

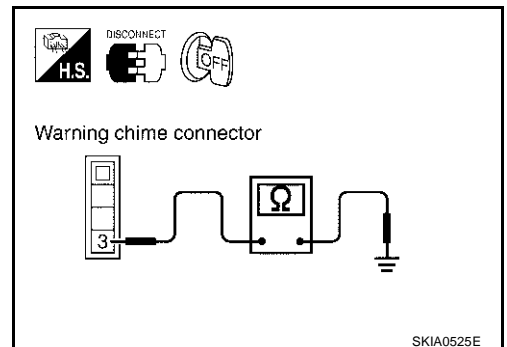

4. CHECK WARNING CHIME OPEN CIRCUIT

Check continuity between warning chime harness connector M74 terminal 3 (BR) and BCM harness connector M4 terminal 12 (BR).

Continuity should exist.

OK or NG

- OK >> GO TO 5.
- NG >> Repair harness or connector.

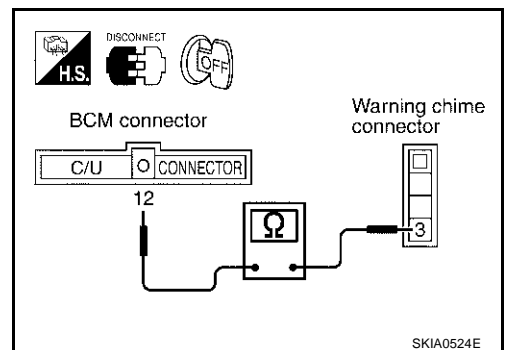

WARNING CHIME

5. CHECK WARNING CHIME OPERATION

1. Connect warning chime connector.
2. Ground warning chime harness connector M74 terminal 3 (BR).

Warning chime should operate.

OK or NG

- OK >> Replace BCM.
NG >> Replace warning chime.

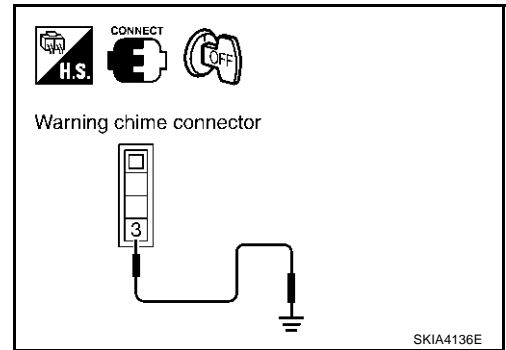

WARNING CHIME

EKS00116

Front Door Switch (Driver side) Inspection

1. CHECK FRONT DOOR SWITCH (DRIVER SIDE) INPUT SIGNAL

With CONSULT-II

Check front door switch ("DOOR SW-DR") in "DATA MONITOR" mode.

When driver's door is open :DOOR SW-DR ON

When driver's door is closed :DOOR SW-DR OFF

Without CONSULT-II

Check front door switch (driver side) in "SWITCH MONITOR" mode, refer to [DI-67, "On Board Diagnosis"](#).

OK or NG

OK >> Front door switch (driver side) is OK.

NG >> GO TO 2.

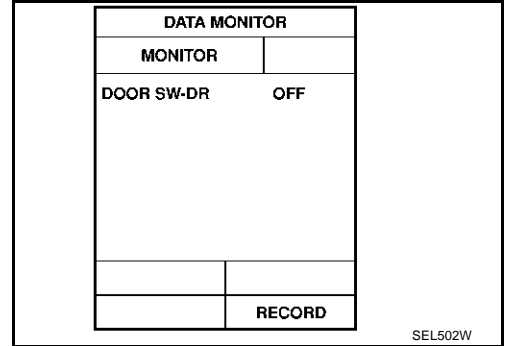

2. CHECK DOOR SWITCH OPEN OR SHORT CIRCUIT

1. Disconnect BCM connector and front door switch (driver side) connector.
2. Check the following.

Terminals				Continuity
(+)		(-)		
Connector	Terminal (Wire color)	Connector	Terminal (Wire color)	
M4	142 (W/R)	B20	1 (W/R)	Yes
		Ground		No

OK or NG

OK >> GO TO 3.

NG >> Repair harness or connector.

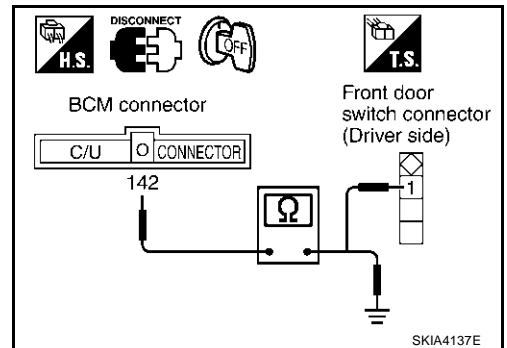

3. CHECK DOOR SWITCH (DRIVER SIDE)

Check continuity between front door switch (driver side) and ground.

Terminals			Condition	Continuity
(+)		(-)		
Connector	Terminal			
B20	1	Ground	Door is opened	Yes
			Door is closed	No

OK or NG

OK >> Front door switch (driver side) is OK.

No >> Replace front door switch (driver side).

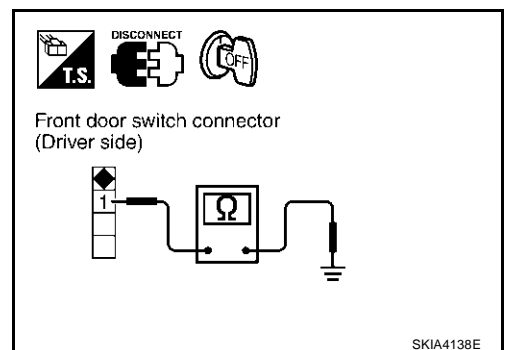

WARNING CHIME

EKS00117

Key Switch Insert Signal Inspection

1. CHECK KEY SWITCH INPUT SIGNAL

With CONSULT-II

Check Key switch ("IGN KEY SW") in "DATA MONITOR" mode.

When key is inserted to ignition key cylinder : IGN KEY SW ON

When key is removed to ignition key cylinder : IGN KEY SW OFF

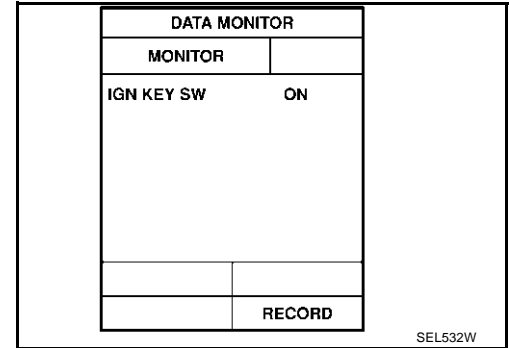

Without CONSULT-II

1. Disconnect the BCM connector.
2. Check voltage between BCM and ground.

Terminals		Condition	Voltage
(+)	(-)		
Connector	Terminal (Wire color)		
M4	69 (PU/W)	key is inserted	Battery voltage
		key is removed	Approx. 0V

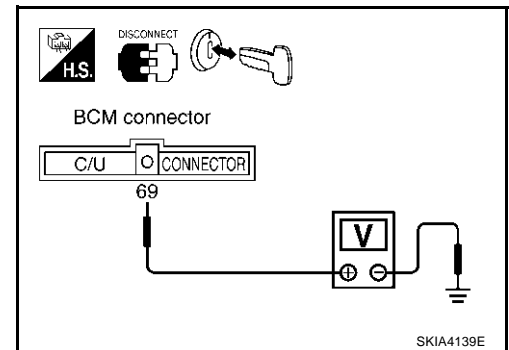

OK or NG

- OK >> Key switch and key lock solenoid (key switch) is OK.
 NG >> GO TO 2.

2. CHECK KEY SWITCH CIRCUIT

1. Remove the key from the ignition key cylinder.
2. Disconnect the key switch and key lock solenoid (key switch) connector.
3. Check continuity between BCM harness connector M4 terminal 69 (PU/W) and key switch and key lock solenoid (key switch) harness connector M64 terminal 4 (PU/W).

Continuity should exist.

OK or NG

- OK >> GO TO 3.
 NG >> Repair harness or connector.

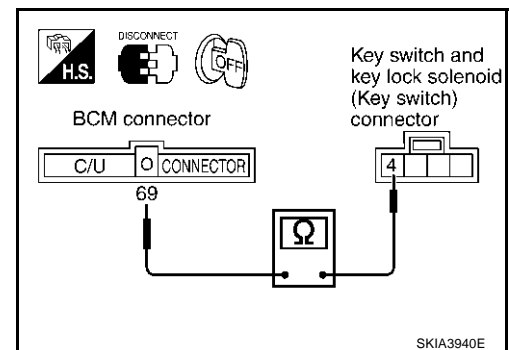

WARNING CHIME

3. CHECK KEY SWITCH (INSERT)

Check continuity key switch and key lock solenoid (key switch).

Connector	Terminal		Condition	Continuity
	(+)	(-)		
M64	3	4	key is inserted	Yes
			key is removed	No

OK or NG

OK >> Inspection end.

NG >> Replace key switch and key lock solenoid (key switch).

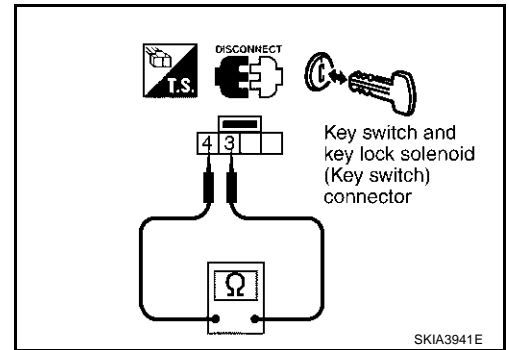

EKS00118

Lighting Switch Input Signal Inspection

1. CHECK LIGHTING SWITCH INPUT SIGNAL

With CONSULT-II

Check Lighting switch ("HD/LMP 1ST SW") in "DATA MONITOR" mode.

When lighting switch is 1ST : HD/LMP 1ST SW ON or 2ND

When lighting switch is OFF : HD/LMP 1ST SW OFF

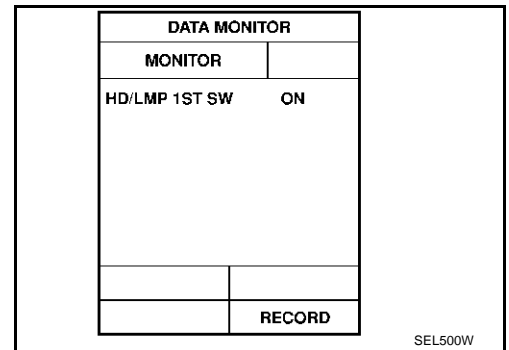

Without CONSULT-II

Check lighting switch in switch monitor mode, refer to [DI-67, "On Board Diagnosis"](#).

OK or NG

OK >> Lighting switch is OK.

NG >> GO TO 2.

2. CHECK TAIL LAMP RELAY CONTROL SIGNAL

1. Turn ignition switch OFF.
2. Disconnect BCM connector.
3. Check voltage between BCM and ground.

Connector	Terminals		Condition	Voltage
	(+)	(-)		
M4	Terminal (Wire color) 3 (R/L)	Ground	Lighting switch 1st or 2nd	Battery voltage
			Lighting switch OFF	Approx. 0V

OK or NG

OK >> Inspection end.

NG >> Check harness for open or short between BCM and tail lamp relay.

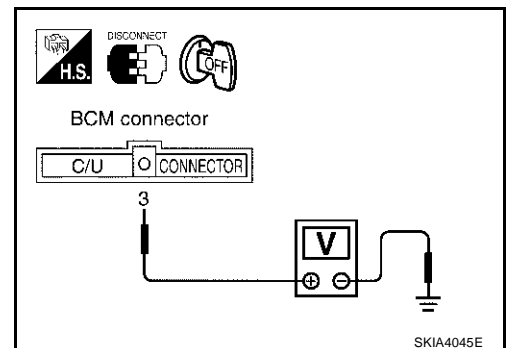

WARNING CHIME

EKS001F7

Seat Belt Buckle Switch Inspection

1. CHECK SEAT BELT BUCKLE SWITCH INPUT SIGNAL

With CONSULT-II

Check seat belt buckle switch ("SEAT BELT SW") in "DATA MONITOR" mode.

When seat belt fastened : SEAT BELT SW ON

When seat belt unfastened : SEAT BELT SW OFF

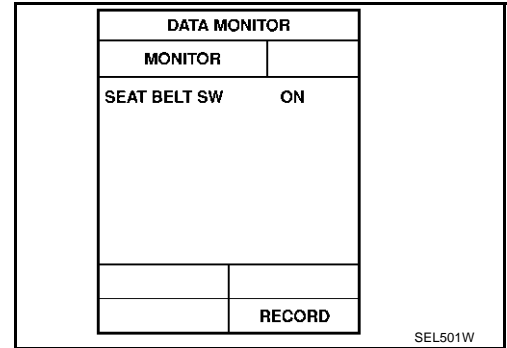

Without CONSULT-II

Check seat belt buckle switch in switch monitor mode, refer to [DI-67, "On Board Diagnosis"](#).

OK or NG

OK >> Seat belt buckle switch is OK.

NG >> GO TO 2.

2. CHECK SEAT BELT BUCKLE SWITCH

1. Turn ignition switch OFF.
2. Disconnect seat belt buckle switch connector.
3. Check continuity seat belt buckle switch.

Terminals (Wire color)		Condition	Continuity
41 (L/B)	15A (B)	Fastened	No
		Unfastened	Yes

OK or NG

OK >> GO TO 3.

NG >> Replace seat belt buckle switch.

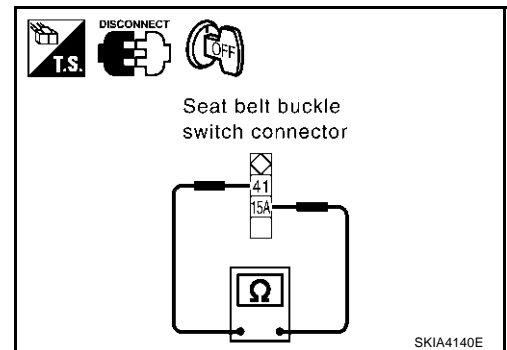

3. CHECK SEAT BELT BUCKLE SWITCH CIRCUIT

1. Disconnect BCM connector.
2. Check continuity between BCM harness connector B4 terminal 147 (G/W) and seat belt buckle switch harness connector B150 terminal 41 (L/B).

Continuity should exist.

OK or NG

OK >> GO TO 4.

NG >> Repair harness or connector.

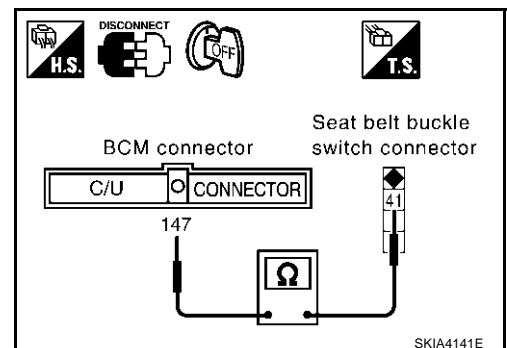

WARNING CHIME

4. CHECK SEAT BELT BUCKLE SWITCH GROUND CIRCUIT

Check continuity between seat belt buckle connector B150 terminal 15A (B) and ground.

15A – Ground : continuity

OK or NG

- OK >> System is OK (Inspection end)
- NG >> Repair harness or connector.

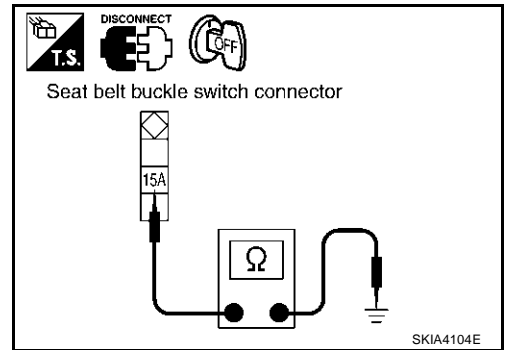

Removal and Installation of Warning Chime

REMOVAL

1. Remove the cluster lid C, refer to [IP-10, "INSTRUMENT PANEL ASSEMBLY"](#).
2. Remove bolt (1), and remove warning chime.

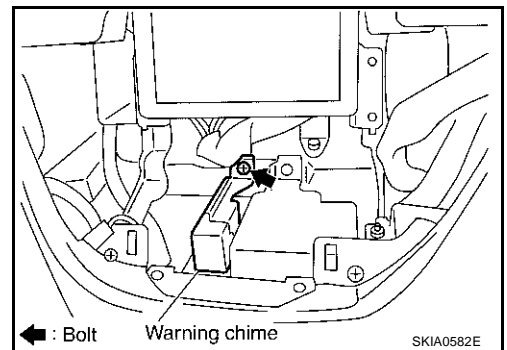

INSTALLATION

Install in the reverse order of removal.

A
B
C
D
E
F
G
H
I
J
DI
L
M

VEHICLE INFORMATION AND INTEGRATED SWITCH SYSTEM /WITHOUT NAVIGATION SYSTEM

PFP:28395

System Description INTEGRATED SWITCH SYSTEM

EKS007A9

Using the multifunction switch at the center of the instrument panel, the controls of the following systems are centralized:

- Auto A/C system
- Vehicle information system
- Audio system
- Hazard switch

The multifunction switch can operate and check the vehicle condition and each setting (vehicle electrical system).

PRECAUTION OF LCD MONITOR

- When passenger compartment temperature is low, the LCD monitor sometimes dims because of the brightness of the back light (small fluorescent light) integrated into the LCD monitor decrease. In this case, the refreshing rate of the picture also becomes low because of the low response of the LCD monitor. When passenger compartment becomes warm, however, the LCD recovers the normal display.
- Sometimes, black or bright dots peculiar to LCD monitor can be seen on the display.
- Back light sometimes flickers or darkens according to the total consumption hours and the number of ON and OFF switching. In this case, the back light should be replaced. (LCD monitor assembly)

POWER SUPPLY AND GROUND

Power Is Supplied At All Times

- through 15 A fuse [No. 52, located in fuse, fusible link and relay box (J/B)]
- to AV control unit terminals 2 and 3, and
- to display terminals 21 and 23.

When Ignition Switch is in ACC or ON Position, Power is Supplied

- through 10 A fuse [No. 21, located in fuse block (J/B) No. 1]
- to AV control unit terminal 6, and
- to display terminal 19, and
- to multifunction switch terminal 1.

When Ignition Switch is in ON or START Position, Power is Supplied

- through 10 A fuse [No. 1, located in fuse block (J/B) No. 1]
- to AV control unit terminal 27.

Ground is Supplied

- to AV control unit terminal 1 and 4
- through body grounds M25 and M115, and
- to multifunction switch terminal 2 and
- to display terminals 22 and 24
- through grounds M24 and M114.

AV COMMUNICATION LINE

AV control unit is connected to the following units by AV communication line. Each unit transmits/receives data with AV communication line.

- Display
- Multifunction switch
- Audio unit
- BOSE speaker amp. (audio amp.)
- Rear view camera control unit
- Low tire pressure warning control unit

VEHICLE INFORMATION AND INTEGRATED SWITCH SYSTEM /WITHOUT NAVIGATION SYSTEM

- Voice activated control module

VEHICLE INFORMATION SYSTEM

- AV control unit is received vehicle information system of signals from combination meter.
- AV control unit is communicating with BCM and combination meter.

1. Press "INFO" switch to display vehicle information display.

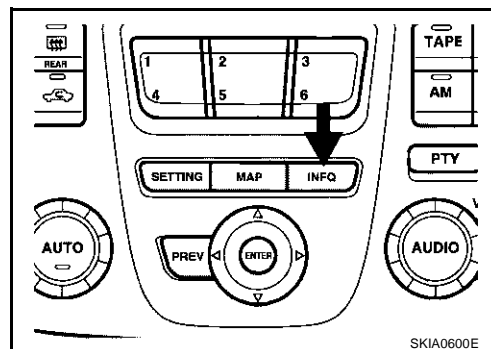

2. Select "Trip Computer", "Fuel Economy", "Maintenance" or "Tire Pressure".

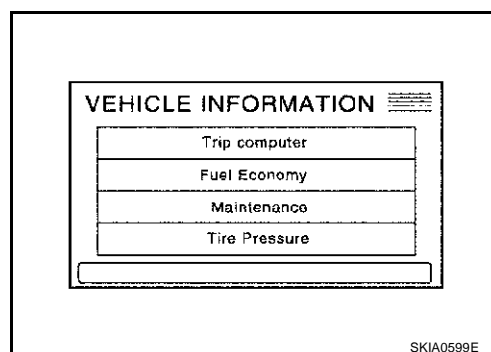

Display items	Display/Setting contents
Trip Computer	Elapsed time
	Driving distance
	Average speed
Fuel Economy	Average fuel economy (MPG)
	Distance to empty (Miles)
	Fuel economy (MPG)
Maintenance (with Maintenance information*)	Fuel economy record
	Maintenance intervals of engine oil and setting of oil change cycle
	Maintenance intervals of oil filter and setting of filter replacement cycle
Tire Pressure	Maintenance intervals of tire and setting of tire replacement cycle
Tire Pressure	Tire pressure information

*: Maintenance information displays the change cycle of engine oil, oil filter and tire on LCD monitor depending on the driving distance specified by a driver or a technician.

VEHICLE INFORMATION AND INTEGRATED SWITCH SYSTEM /WITHOUT NAVIGATION SYSTEM

Trip Computer Information

1. Select "Trip Computer".
2. Elapsed Time, Driving Distance and Average Speed are displayed as Trip Computer information.

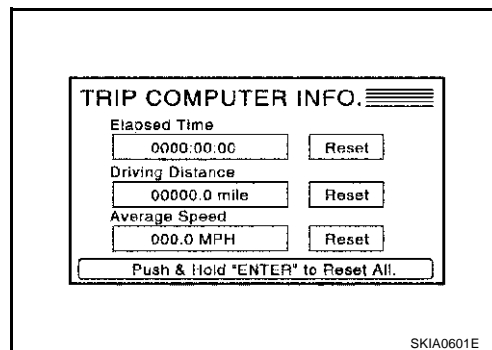

Fuel Economy Information

1. Select "Fuel Economy".
2. Average Fuel Economy, Distance to Empty, Fuel Economy are displayed as Fuel Economy information.

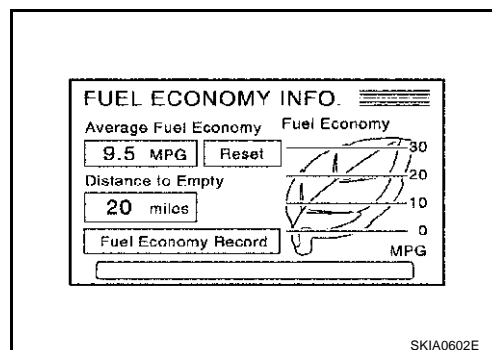

3. Select "Fuel Economy Record". The average fuel consumption history will be displayed in graph along with the average for the previous Reset – to – Reset period.

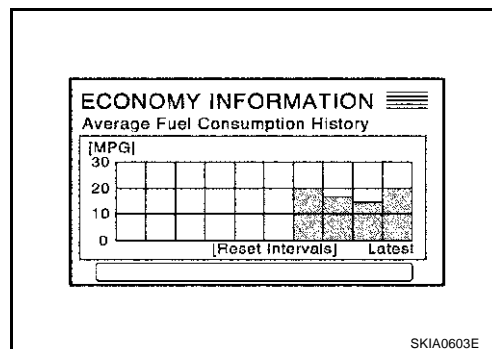

Maintenance Information

1. Select "Maintenance".
2. Engine Oil, Oil Filter and Tire Rotation are displayed as Maintenance information.

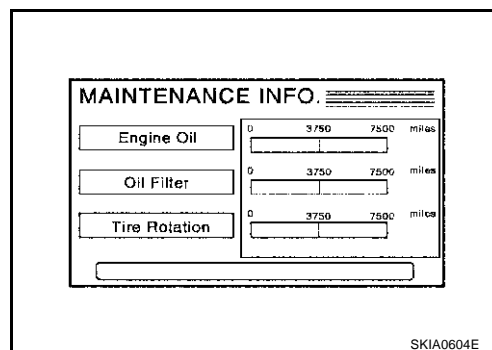

VEHICLE INFORMATION AND INTEGRATED SWITCH SYSTEM /WITHOUT NAVIGATION SYSTEM

Tire Pressure Information

1. Select "Tire Pressure".
2. Tire pressure displayed as Tire Pressure information.

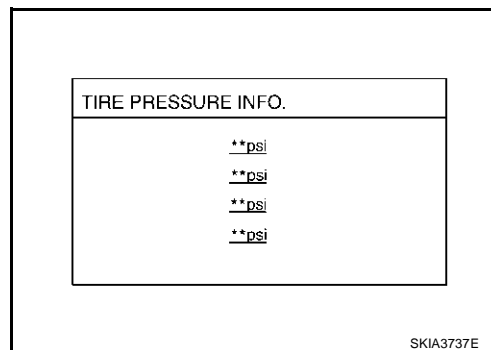

NOTE:

- When air pressure becomes 180 kPa (1.8 kg/cm² , 26 psi) or less, "LOW PRESSURE" warning is indicated.
- When air pressure becomes 70 kPa (0.7 kg/cm² , 10 psi) or less, "FLAT TIRE" warning is indicated.
- When pressure is not detected or tire pressure system has malfunction "*** psi" is indicated.
- Indication with yellow frame for the malfunctioning tire.

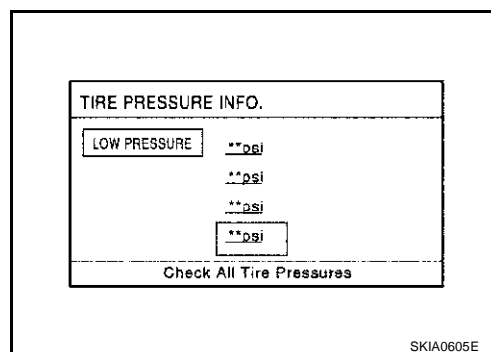

SETTING OF VEHICLE STATUS

- Setting of electric status can be changed by multifunction switch. The signal is sent to BCM through AV control unit to change vehicle electric system setting.
 - AV control unit is communicating with BCM and combination meter.
1. Press "SETTING" switch to display vehicle information display.

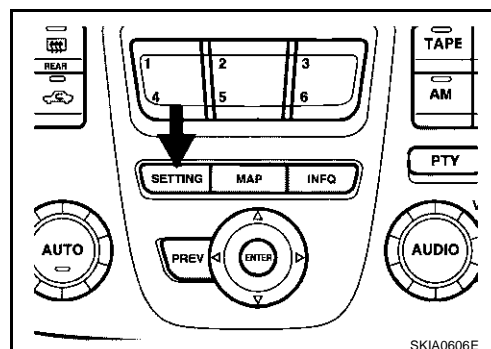

2. Select "Vehicle Electronic System".

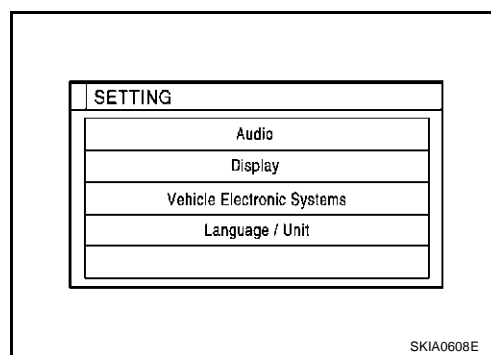

3. Select a vehicle status shown on the display.

VEHICLE INFORMATION AND INTEGRATED SWITCH SYSTEM /WITHOUT NAVIGATION SYSTEM

Adjustable vehicle status

- Lift Steering Column When Exiting Vehicle
- Adjust Driver Seat When Exiting Vehicle
- Illuminate Interior When Unlocking Vehicle
- Interior Lights Off Delay

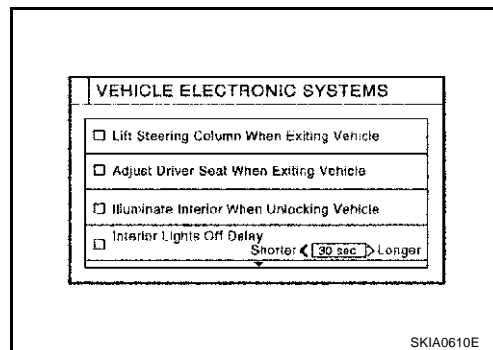

- Sensitivity of Automatic Headlights
- Automatic Headlights Off Delay
- Key Remote Response - Horn/Lights
- Remote Custom Settings

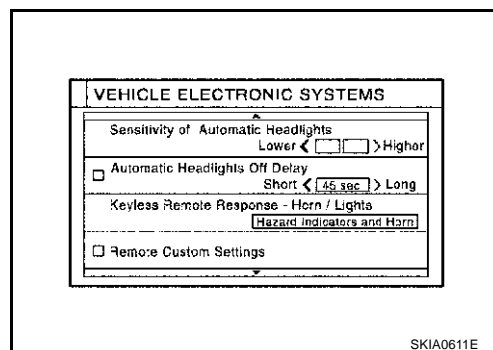

- Return All Settings to Default

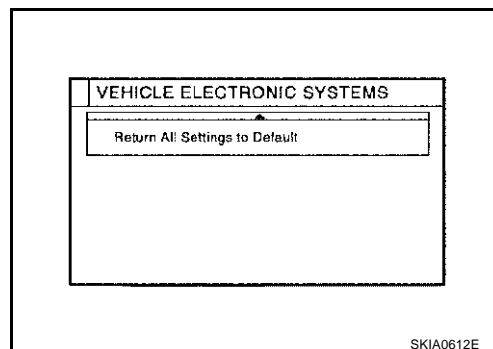

VEHICLE INFORMATION AND INTEGRATED SWITCH SYSTEM /WITHOUT NAVIGATION SYSTEM

Adjustable vehicle status

Setting items	Setting variations	Initial setting	Operation
Lift Steering Column When Exiting Vehicle	ON/OFF	ON	<p>The steering column automatically tilts up when the driver gets out, and returns to the original position when the driver gets on.</p> <ul style="list-style-type: none"> When driver door is closed and key removed from ignition key cylinder, the steering column tilts up. When driver door is open and key is turned to OFF, the steering column tilts up.
Adjust Driver Seat When Exiting Vehicle	ON/OFF	ON	<p>The driver's seat automatically slides backward when the driver gets out, and returns to the original position when the driver gets on.</p>
Illuminate Interior When Unlocking Vehicle	ON/OFF	ON	<p>The interior room lamps are illuminate automatically when the door unlocked with key or key fob.</p>
Interior Lights Off Delay	OFF/15/30/45 sec.	30 sec.	<p>Interior room lamp timer period can be changed in this mode. Selects interior room lamp timer.</p>
Sensitivity of Automatic Headlights	1/2/3/4	3	<p>Sensitivity of auto light sensor can be adjusted.</p>
Automatic Headlights Off Delay	OFF/20/45/90/120/150/180 sec.	45 sec.	<p>Auto light delay off timer period can be changed in this mode. Selects auto light delay off timer.</p>
Key Remote Response - Horn/Lights	Hazard indicators only /Hazard indicators and horn	Hazard indicators only	<p>Hazard indicators Only:</p> <ul style="list-style-type: none"> Lock operation: The hazard warning lamp flash twice when lock the doors with key fob. Unlock operation: No response. <p>Hazard indicators and horn:</p> <ul style="list-style-type: none"> Lock operation: The hazard warning lamp flash twice and horn sounds once when lock the doors with key fob. Unlock operation; The hazard warning lamp flash once when unlock the doors with key fob.
Remote Custom Settings	ON/OFF	ON	<p>The driving position -seat and steering column- and the audio setting -current source and radio station presets- are set to the same condition you made last time by identifying the key fob ID.</p> <p>This function operates when unlock the doors by using the key fob.</p> <p>NOTE: It is necessary to memorize the driving position before using this function.</p>
Return All Settings to Default	None	None	<p>If this key is selected, all vehicle electronic systems setting are return to default.</p>

A
B
C
D
E
F
G
H
I
J
DI
L
M

VEHICLE INFORMATION AND INTEGRATED SWITCH SYSTEM /WITHOUT NAVIGATION SYSTEM

WARNING INDICATIONS

When combination meter receives warning signal from some control units or sensors, then combination meter warning lamp is illuminated.

Then combination meter sends warning signal to AV control unit to display warning indications on the screen.

Warning indicators	Warning lamps in instrument panel	Warning detection and cancel conditions		Cases of malfunction
MALFUNCTION	SERVICE ENGINE SOON	Detection condition	Warning lamp ON signal is detected while engine is running.	ECM malfunction
		Cancel condition	Warning lamp OFF signal is detected.	
ENGINE OIL PRES-SURE	Engine oil pressure	Detection condition	Warning lamp ON signal is detected for at least approx. 5 seconds while engine is running. [Engine oil pressure: MAX. approx. 29 kPa (0.3 kg/cm ² , 4psi)]	Engine oil pressure decreases
		Cancel condition	Warning lamp OFF signal is detected. [Engine oil pressure: MIN. approx. 29 kPa (0.3 kg/cm ² , 4psi)]	
SUPPLEMENTAL AIR BAG	Air bag	Detection condition	Warning lamp ON signal is detected for at least approx. 10 seconds after ignition switch is turned ON.	SRS air bag system malfunction
		Cancel condition	Warning lamp OFF signal is detected.	
LOW BRAKE FLUID	Brake	Detection condition	Warning lamp ON signal (fluid level) is detected.	Low brake fluid level
		Cancel condition	Warning lamp OFF signal is detected.	
OVERHEATING	-	Detection condition	Engine coolant temperature as being approx. 119°C (246°F) min.	Engine cooling system malfunction
		Cancel condition	Engine coolant temperature as being approx. 105°C (221°F) max.	
CHARGE	Charge	Detection condition	Warning lamp ON signal is detected while engine is running. Charging system malfunction	Charging system malfunction
		Cancel condition	Warning lamp OFF signal is detected.	
LOW WASHER FLUID	-	Detection condition	Washer liquid level falls below approx. 0.4 ℓ (.7/8 US qt, 3/4 Imp pt)	Low washer liquid level
		Cancel condition	Except above condition.	
LOW FUEL	Fuel level	Detection condition	After warning lamp ON signal is detected, vehicle is driven for over specified distance. (Fuel level: Approx. 14.0 ℓ 14-3/4 US qt, 12-3/8 Imp pt)	Low fuel level
		Cancel condition	Warning lamp OFF signal is detected.	
PARKING BRAKE	Brake	Detection condition	Parking brake ON signal is detected while vehicle is running [approx. 5 km/h (3 MPH) or faster].	Parking brake remains engaged.
		Cancel condition	Vehicle is stopped, or parking brake OFF signal is detected.	
DOOR OPEN	Door	Detection condition	Vehicle is running [approx. 5 km/h (3 MPH) or faster] and door ajar of any of the doors is detected.	Door is open
		Cancel condition	Vehicle is stopped and all the doors lock.	
ANTI-LOCK BRAKE	ABS	Detection condition	Warning lamp ON signal is detected when engine is running.	ABS control system malfunction
		Cancel condition	Warning lamp OFF signal is detected.	

VEHICLE INFORMATION AND INTEGRATED SWITCH SYSTEM /WITHOUT NAVIGATION SYSTEM

Warning indicators	Warning lamps in instrument panel	Warning detection and cancel conditions		Cases of malfunction	A
VEHICLE DYNAMIC CONTROL	VDC	Detection condition	Warning lamp ON signal is detected when engine is running.	VDC system malfunction	B
		Cancel condition	Warning lamp OFF signal is detected.		C
TRACTION CONTROL SYSTEM	TCS	Detection condition	Warning lamp ON signal is detected when engine is running.	TCS system malfunction	D
		Cancel condition	Warning lamp OFF signal is detected.		E
AUTOMATIC TRANSMISSION OIL TEMPERATURE	AT CHECK	Detection condition	Warning lamp ON signal is detected after ignition switch is turned ON.	TCM system malfunction	F
		Cancel condition	Warning lamp OFF signal is detected.		G
TIRE PRESSURE		Detection condition	Warning lamp ON signal is detected after ignition switch is turned ON.	Low tire pressure warning control unit system malfunction	H
		Cancel condition	Warning lamp OFF signal is detected.		I
LOW TIRE PRESSURE (TIRE PRESSURE INFO.)	Tire Pressure	Detection condition	Tire pressure 180 kPa (1.8 kg/cm ² , 26 psi) is detected while vehicle is running.	Tire pressure is low	J
		Cancel condition	Except above condition.		L
FLAT TIRE (TIRE PRESSURE INFO.)		Detection condition	Tire pressure 70 kPa (0.7 kg/cm ² , 10 psi) is detected while vehicle is running.	Flat tire	M
		Cancel condition	Except above condition.		
CRUISE CONTROL	SET	Detection condition	Warning lamp ON signal is detected after ignition switch is turned ON.	ASC system malfunction	
		Cancel condition	Warning lamp OFF signal is detected.		

DI

VEHICLE INFORMATION AND INTEGRATED SWITCH SYSTEM /WITHOUT NAVIGATION SYSTEM

Precautions for AV Control Unit Replacement

EKS006DP

The AV control unit has the following information stored in its memory. Record the memory contents before replacing the control unit, and input them in the new unit as necessary.

- | | |
|--|---|
| <p><FM-AM></p> <p><CD></p> <p><Sound quality></p> <p><Image quality></p> | <ul style="list-style-type: none"> ● Preset frequency ● Area for indicating station, selection of overlapped stations ● Program status ● Volume balance memory set values ● Equalizer memory set values ● Brightness of light when ON/OFF ● Dimming switching ● Display color switching |
|--|---|

NOTE:

Only removing the battery does not erase the memory.

Component Parts and Harness Connector Location

EKS006DQ

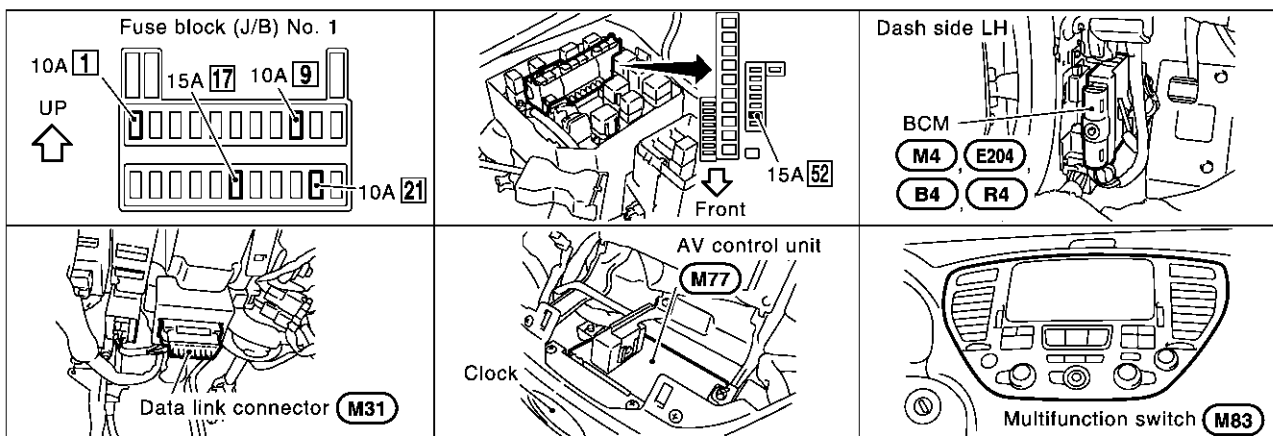

SKIA3738E

VEHICLE INFORMATION AND INTEGRATED SWITCH SYSTEM /WITHOUT NAVIGATION SYSTEM

Schematic

EKS006DR

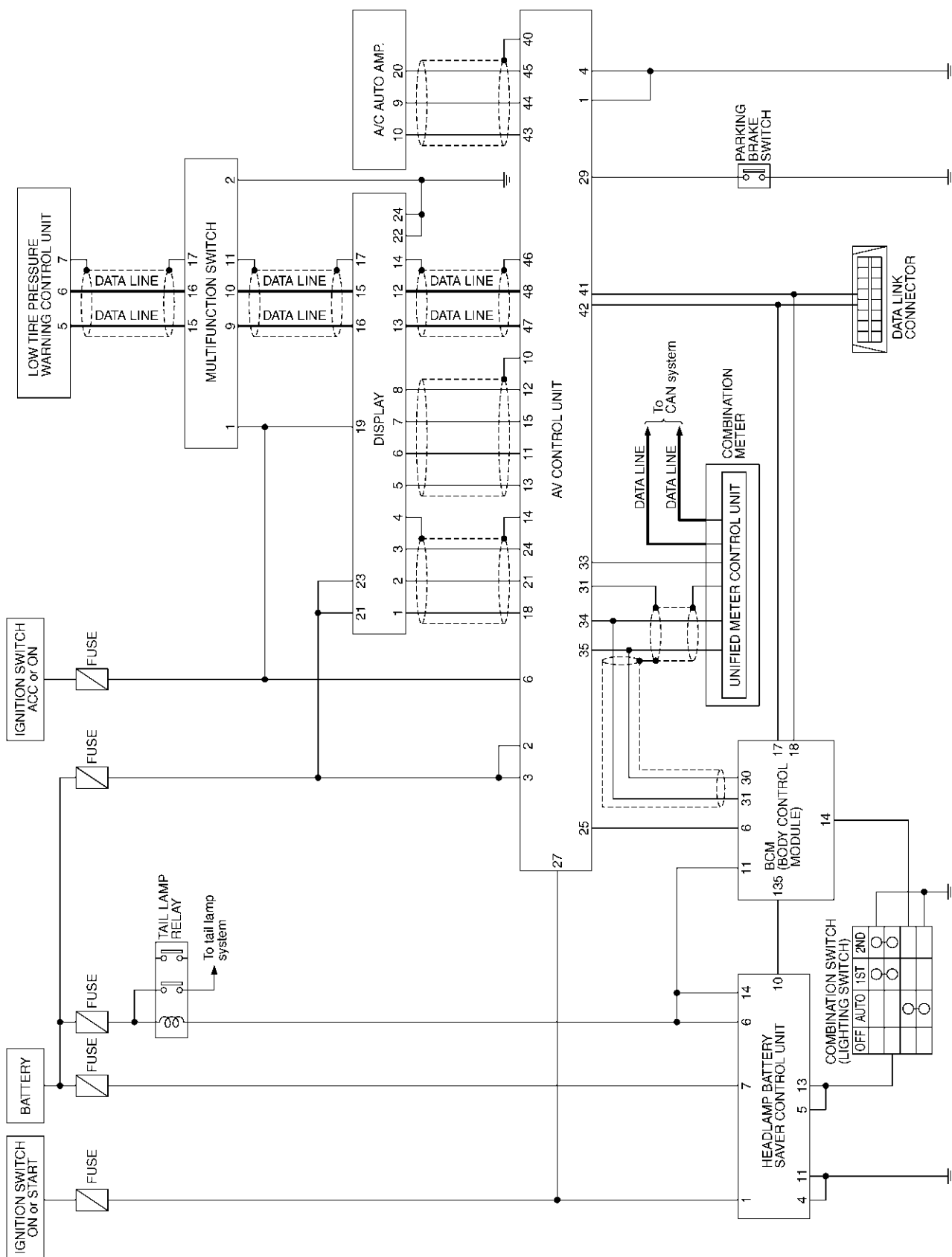

A
B
C
D
E
F
G
H
I
J
DI
L
M

TKWM0725E

VEHICLE INFORMATION AND INTEGRATED SWITCH SYSTEM /WITHOUT NAVIGATION SYSTEM

EKS006DS

Wiring Diagram — INF/D —

DI-INF/D-01

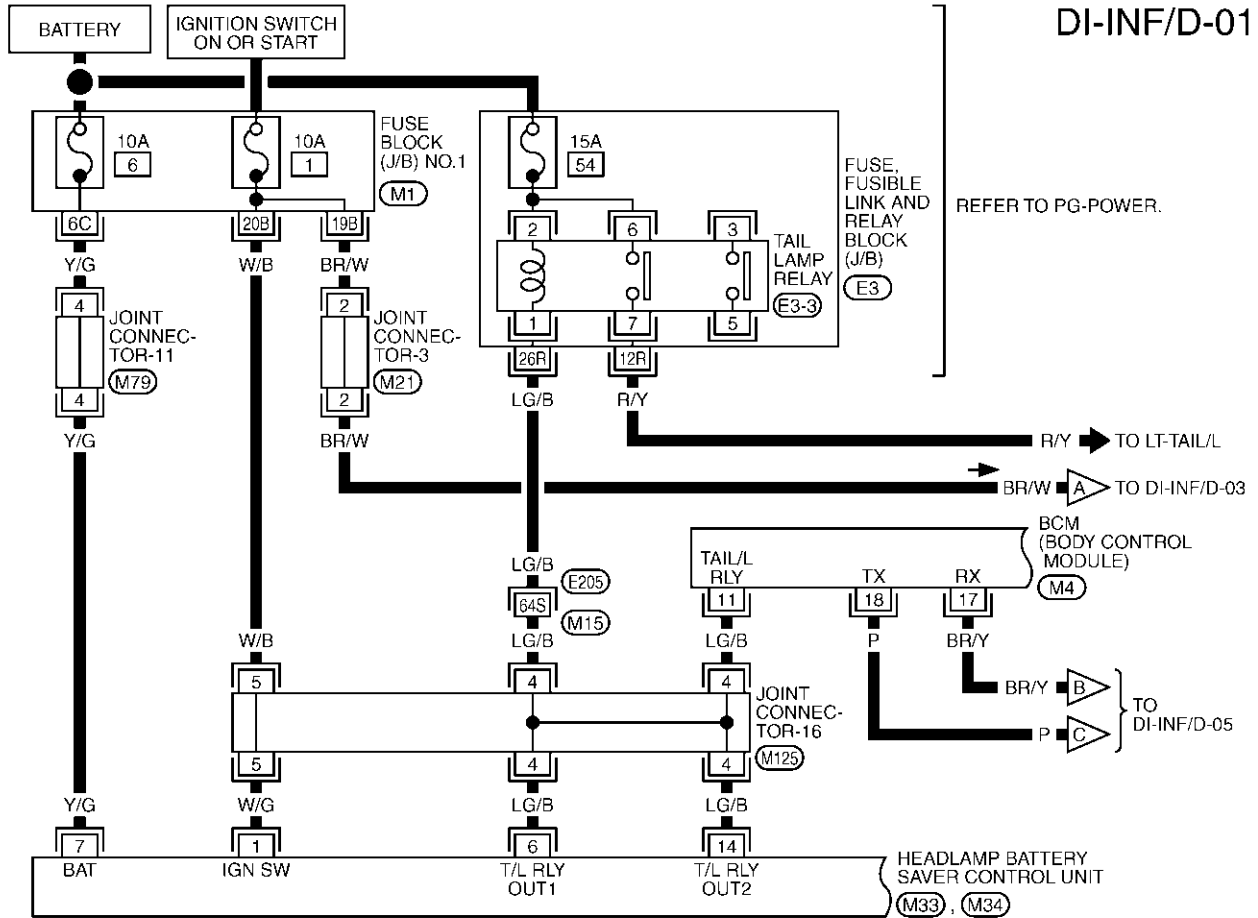

REFER TO PG-POWER.

TO LT-TAIL/L
TO DI-INF/D-03
BCM (BODY CONTROL MODULE) (M4)
TO DI-INF/D-05

HEADLAMP BATTERY SAVER CONTROL UNIT (M33, M34)

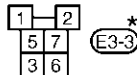
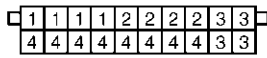
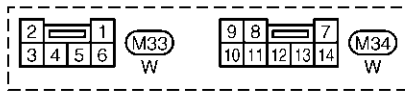
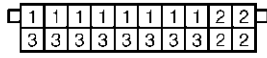

REFER TO THE FOLLOWING.

- (E205) -SUPER MULTIPLE JUNCTION (SMJ)
- (M1) -FUSE BLOCK-JUNCTION BOX (J/B) NO.1
- (E3) -FUSE,FUSIBLE LINK AND RELAY BLOCK (J/B)
- (M4) -ELECTRICAL UNITS

*: THIS CONNECTOR IS NOT SHOWN IN "HARNESS LAYOUT", PG SECTION.

TKWM0362E

VEHICLE INFORMATION AND INTEGRATED SWITCH SYSTEM /WITHOUT NAVIGATION SYSTEM

DI-INF/D-03

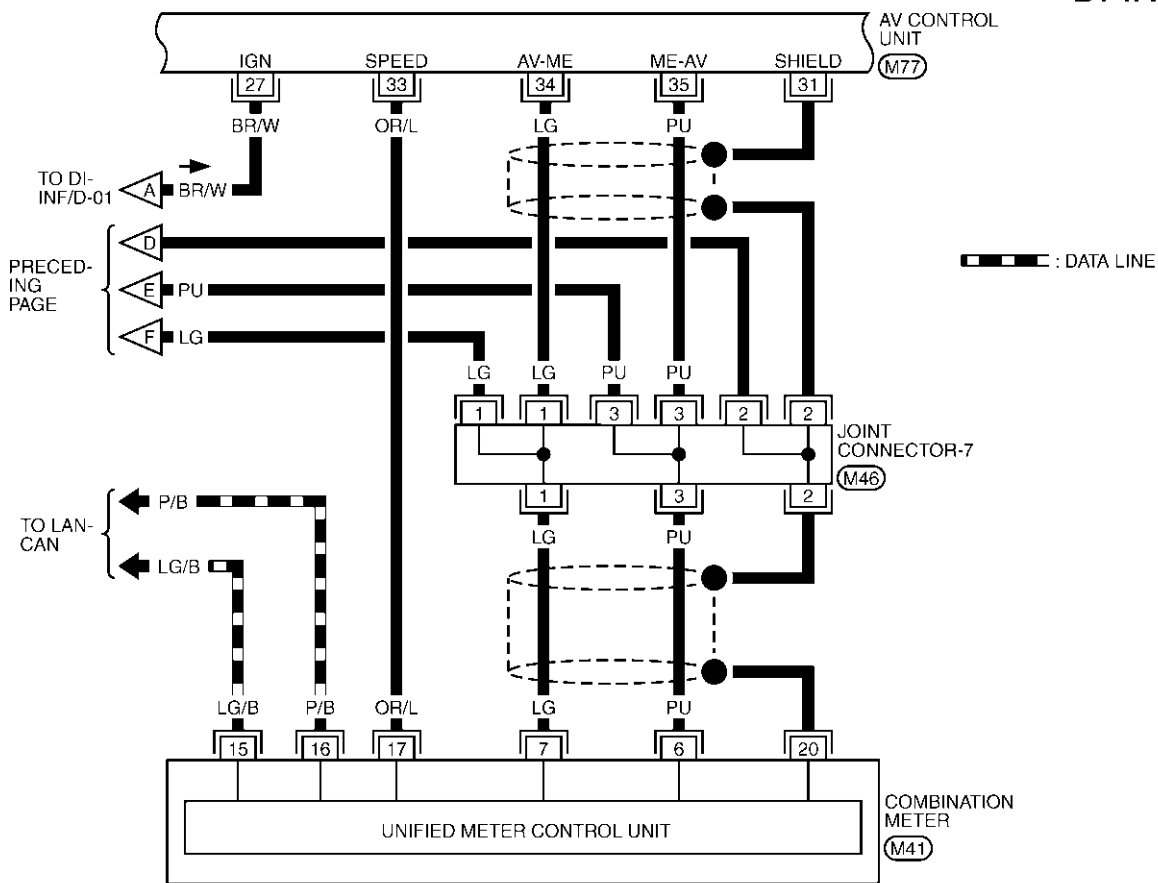

1	2	3	4	5	6	7	8	9		
10	11	12	13	14	15	16	17	18	19	20

(M41)
BR

1	1	1	2	2	2	3	3	3	3
4	4	4	4	4	4	5	5	5	5

(M46)
B

48	45	42	39	37	35	33	30	27
47	44	41	38	36	34	32	29	26
46	43	40				31	28	25

(M77)
GY

TKWM0081E

VEHICLE INFORMATION AND INTEGRATED SWITCH SYSTEM /WITHOUT NAVIGATION SYSTEM

DI-INF/D-04

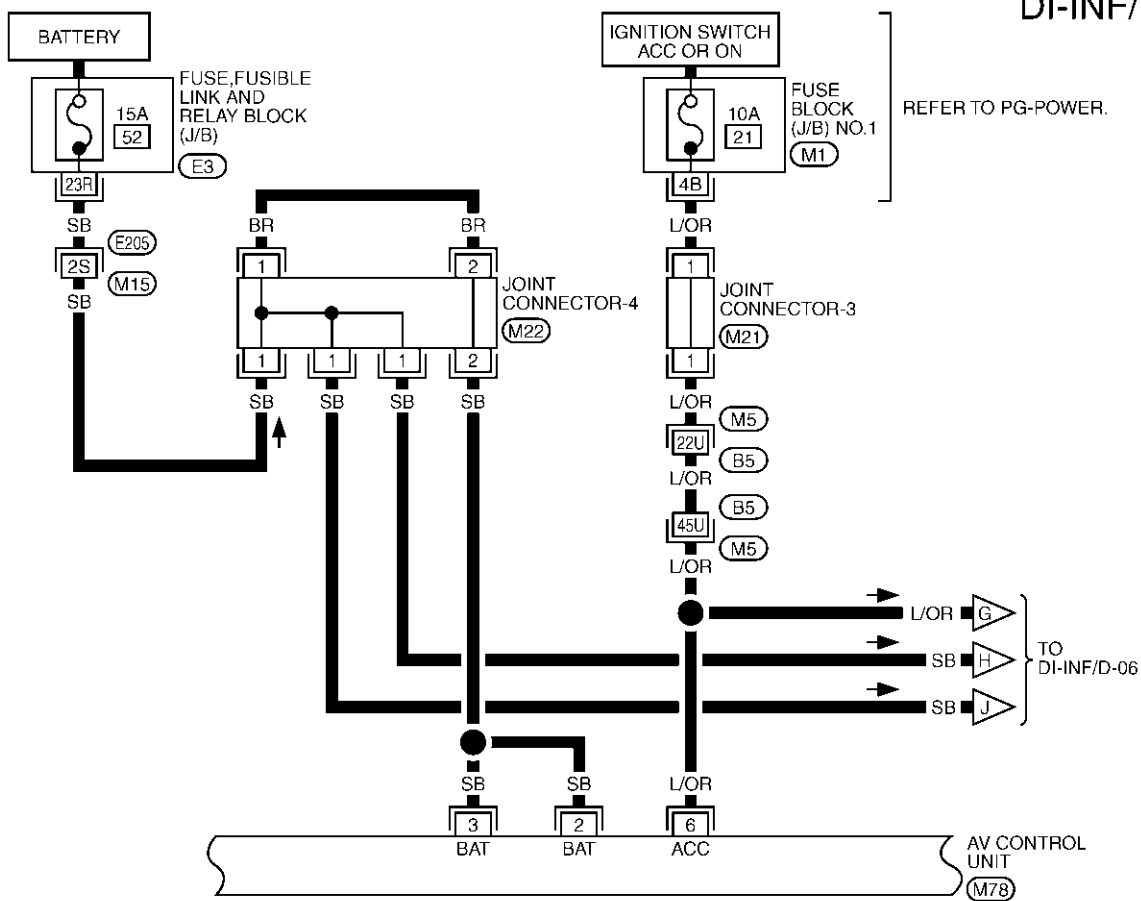

1	1	1	1	1	1	1	1	2	2
3	3	3	3	3	3	3	2	2	2

(M21) GY

1	1	1	1	1	1	2	2	2	2
3	3	3	3	3	3	4	4	4	4

(M22) L

24	21	18	15	13	11	9	6	3
23	20	17	14	12	10	8	5	2
22	19	16			7	4	1	

(M78) W

REFER TO THE FOLLOWING.

- (M5), (E205) -SUPER MULTIPLE JUNCTION (SMJ)
- (M1) -FUSE BLOCK-JUNCTION BOX (J/B) NO.1
- (E3) -FUSE,FUSIBLE LINK AND RELAY BLOCK (J/B)

TKWM0269E

VEHICLE INFORMATION AND INTEGRATED SWITCH SYSTEM /WITHOUT NAVIGATION SYSTEM

DI-INF/D-05

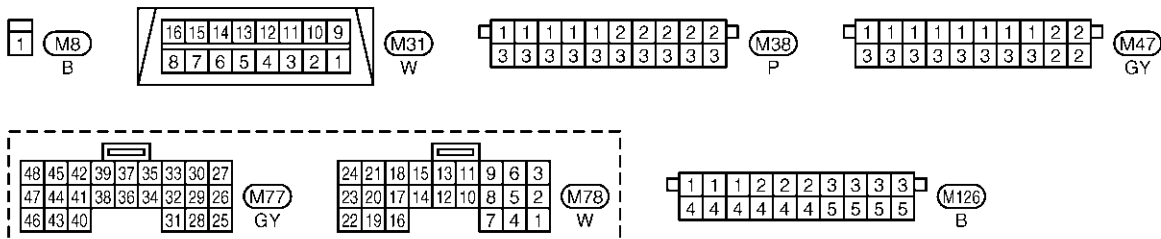
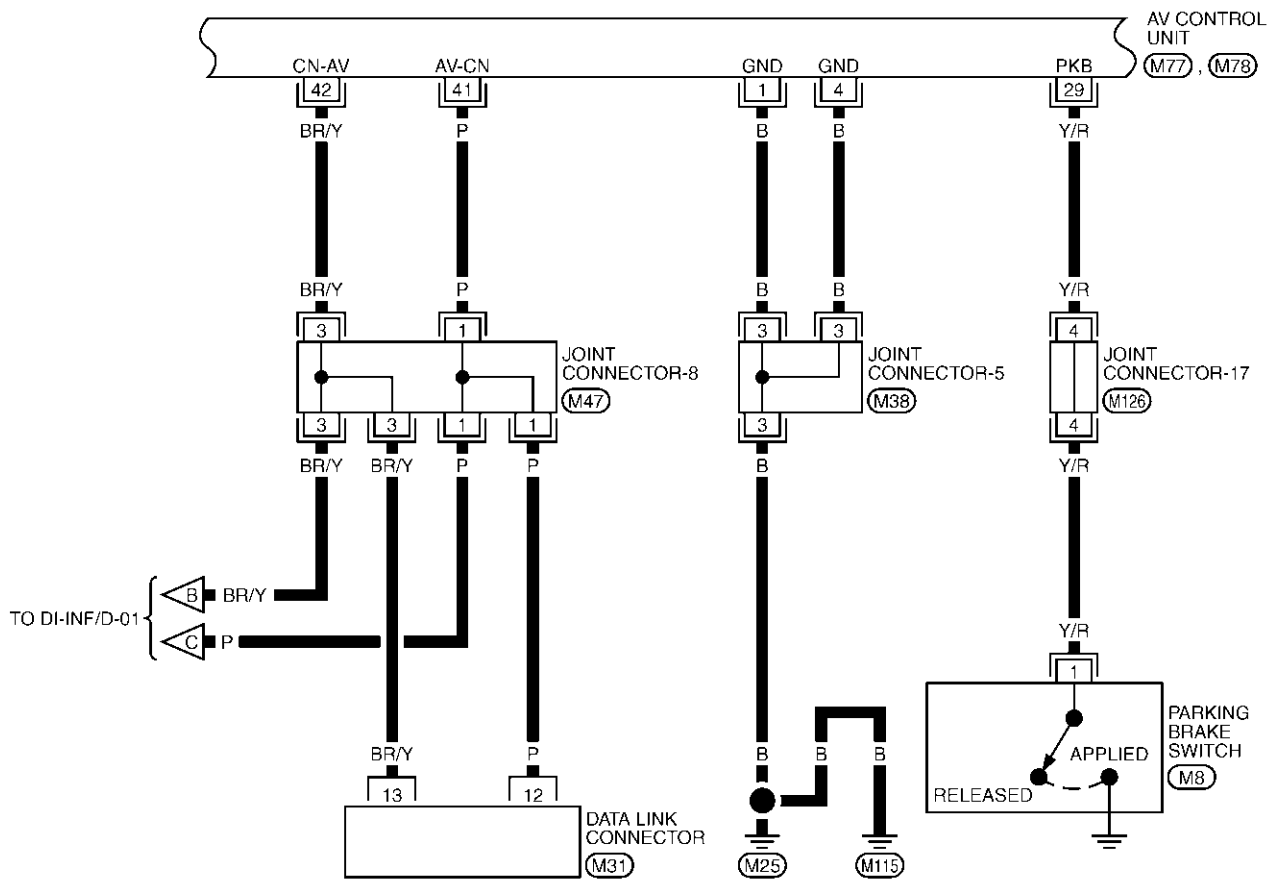

TKWM0270E

VEHICLE INFORMATION AND INTEGRATED SWITCH SYSTEM /WITHOUT NAVIGATION SYSTEM

DI-INF/D-06

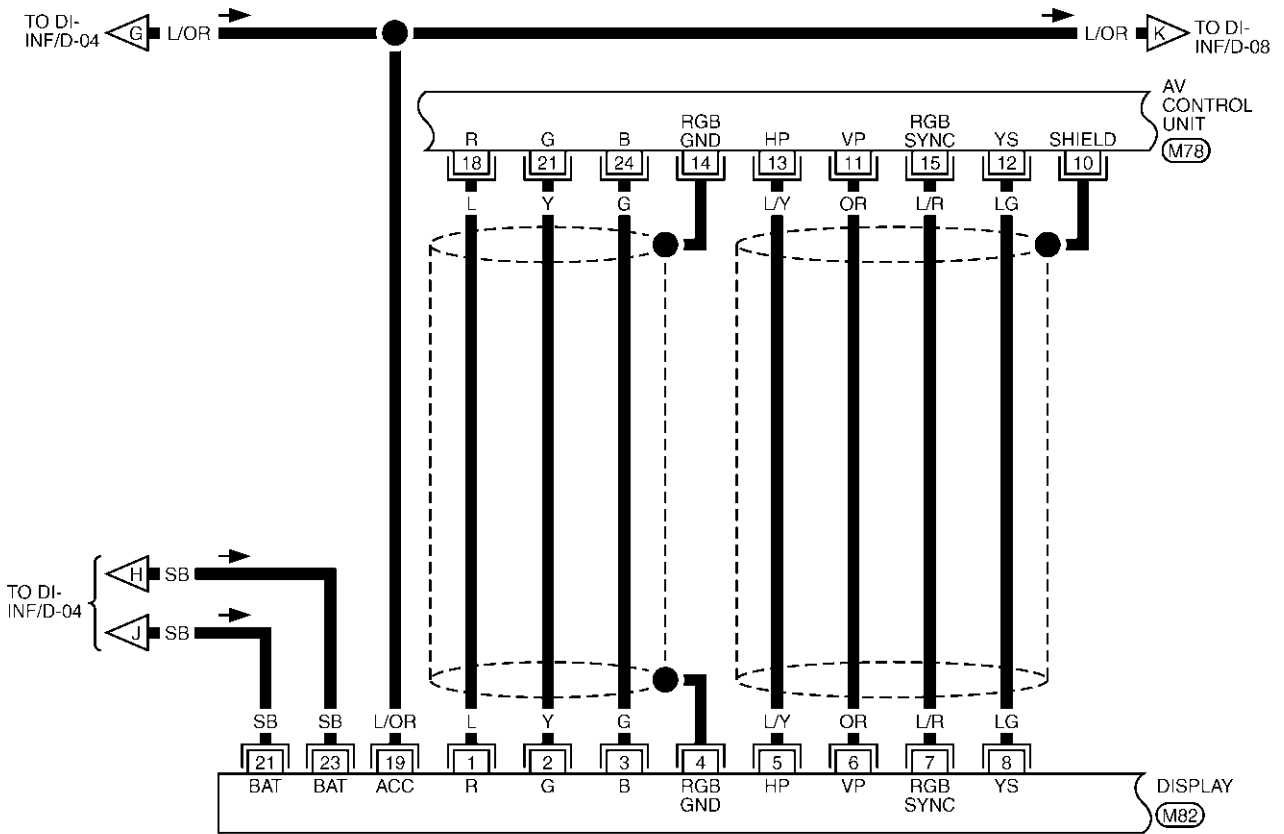

24	21	18	15	13	11	9	6	3
23	20	17	14	12	10	8	5	2
22	19	16		7	4	1		

(M78)
W

24	22	20	18	16	14	10	8	6	4	2		
23	21	19	17	15	13	12	11	9	7	5	3	1

(M82)
GY

TKWM0726E

VEHICLE INFORMATION AND INTEGRATED SWITCH SYSTEM /WITHOUT NAVIGATION SYSTEM

DI-INF/D-07

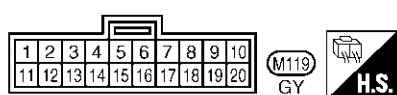
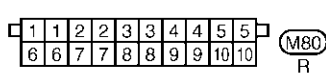
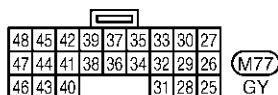
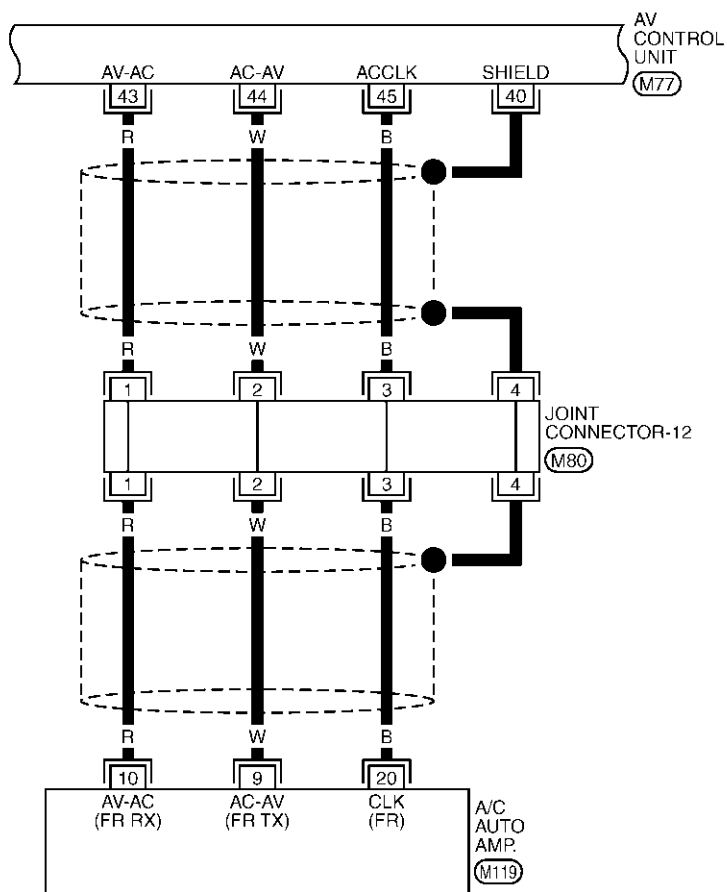

TKWM0727E

VEHICLE INFORMATION AND INTEGRATED SWITCH SYSTEM /WITHOUT NAVIGATION SYSTEM

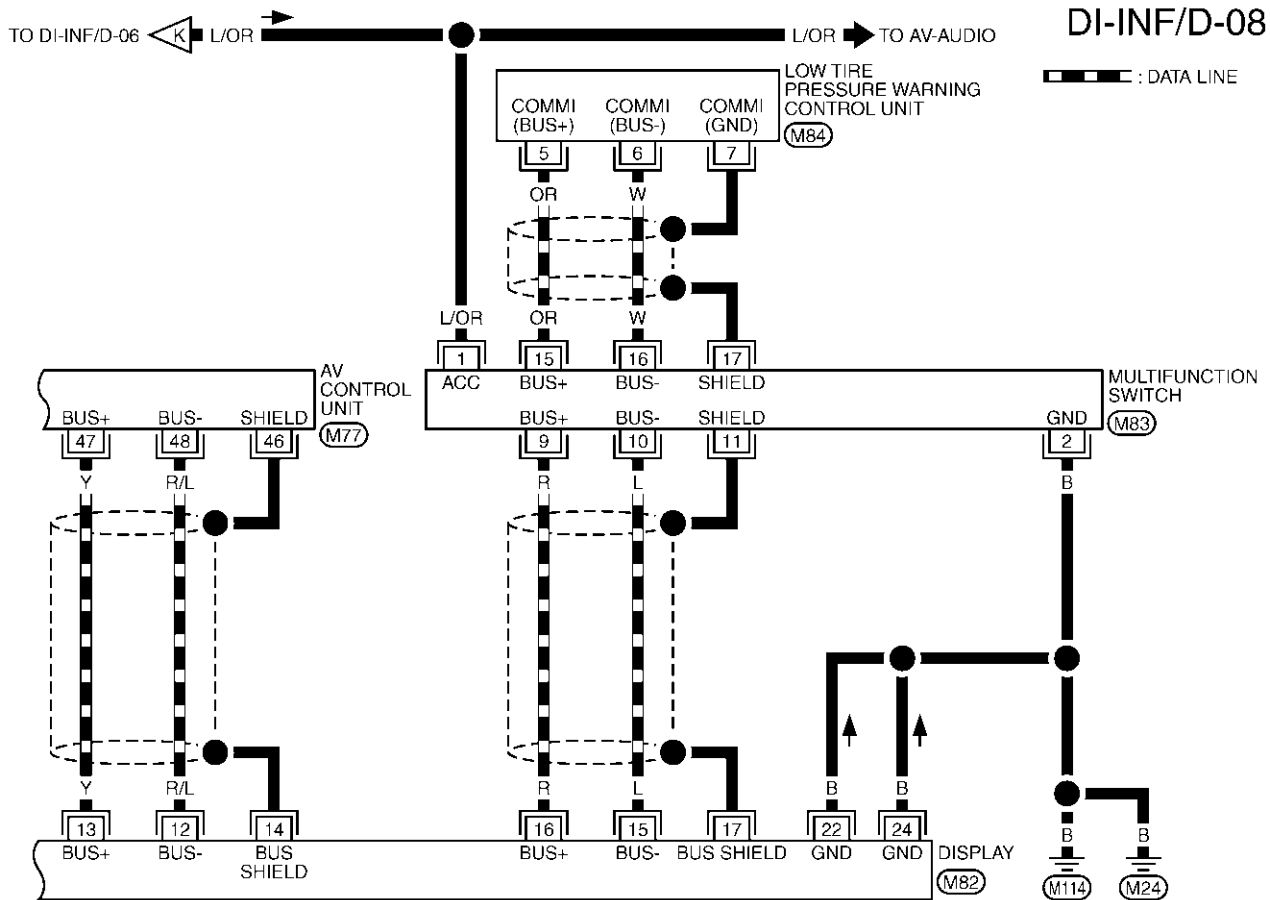

48	45	42	39	37	35	33	30	27
47	44	41	38	36	34	32	29	26
46	43	40			31	28	25	

(M77) GY

24	22	20	18	16	14	10	8	6	4	2		
23	21	19	17	15	13	12	11	9	7	5	3	1

(M82) GY

20	18	16	14	12	8	6	4	2		
19	17	15	13	11	10	9	7	5	3	1

(M83) W

7	6	5	4	3	2	1		
16	15	14	13	12	11	10	9	8

(M84) W

A
B
C
D
E
F
G
H
I
J
DI
L
M

TKWM0728E

VEHICLE INFORMATION AND INTEGRATED SWITCH SYSTEM /WITHOUT NAVIGATION SYSTEM

Schematic

EKS006QW

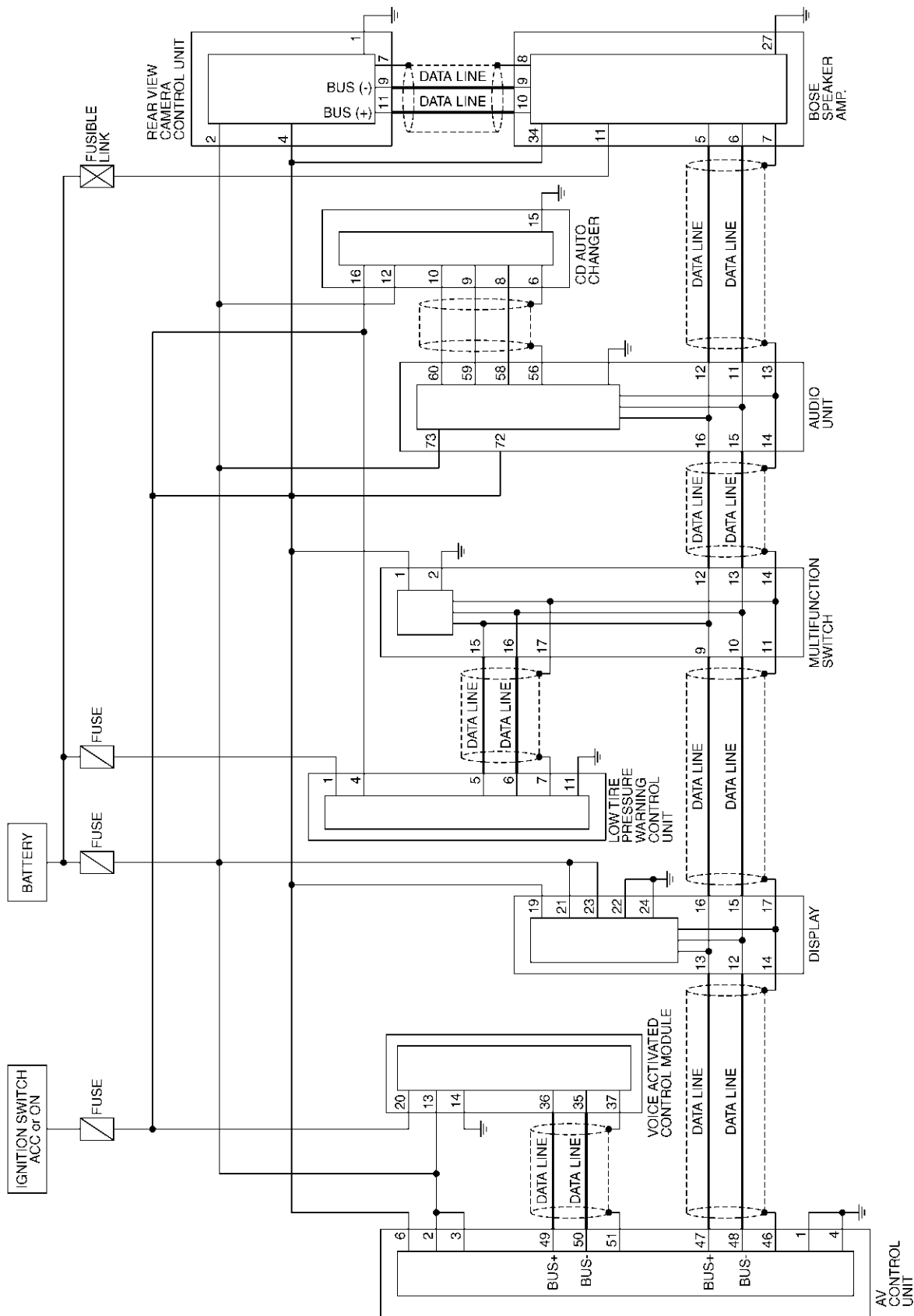

TKWM0294E

VEHICLE INFORMATION AND INTEGRATED SWITCH SYSTEM /WITHOUT NAVIGATION SYSTEM

Wiring Diagram — COMM —

EKS006QX

DI-COMM-01

A
B
C
D
E
F
G
H
I
J
K
L
M

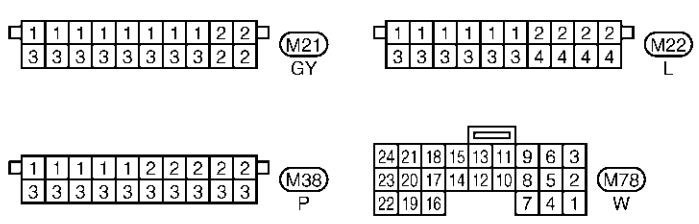
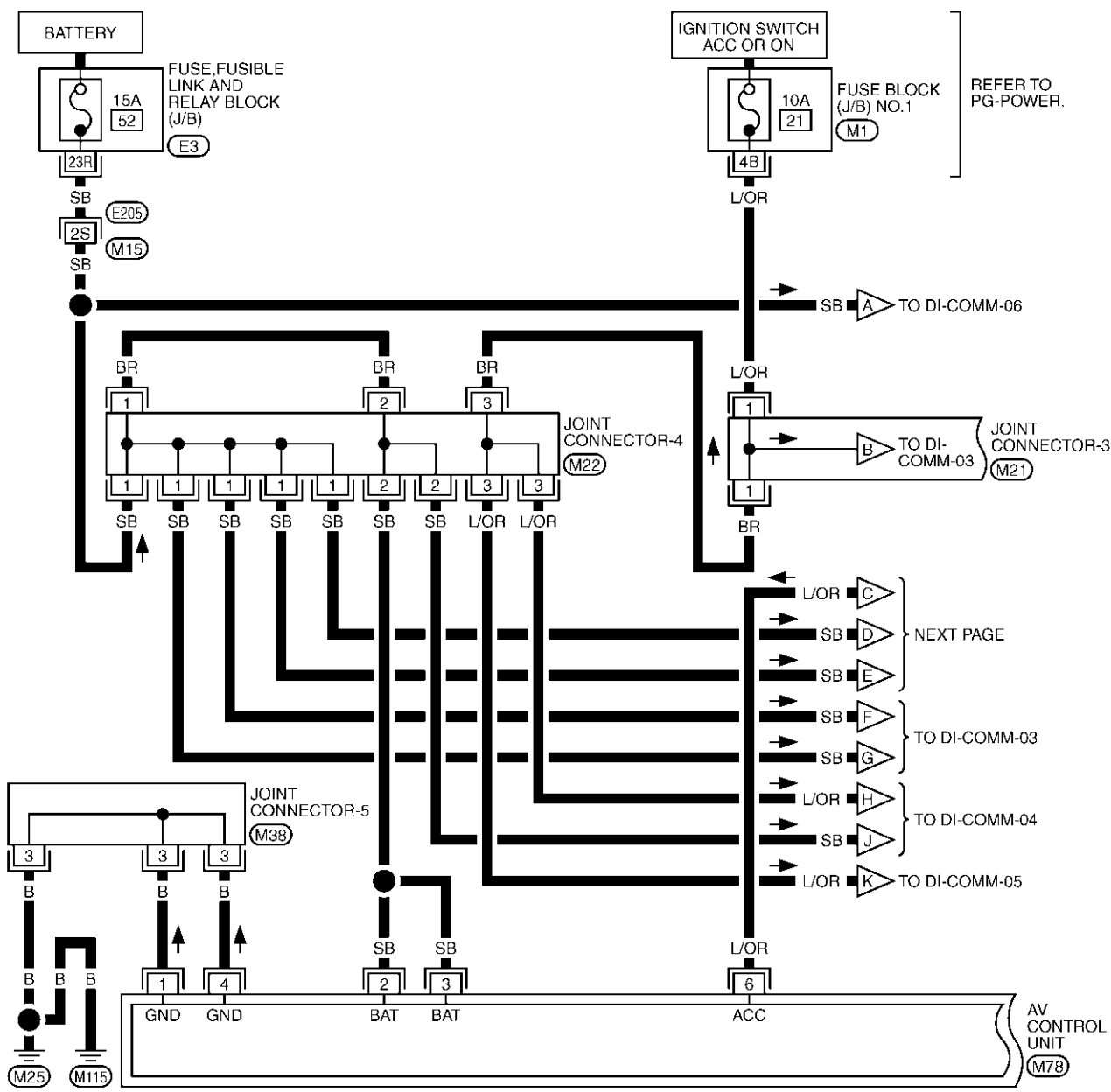

REFER TO THE FOLLOWING.
 (E205) -SUPER MULTIPLE JUNCTION (SM.J)
 (M1) -FUSE BLOCK-JUNCTION BOX (J/B) NO.1
 (E3) -FUSE,FUSIBLE LINK AND RELAY BLOCK (J/B)

TKWM0295E

VEHICLE INFORMATION AND INTEGRATED SWITCH SYSTEM /WITHOUT NAVIGATION SYSTEM

DI-COMM-02

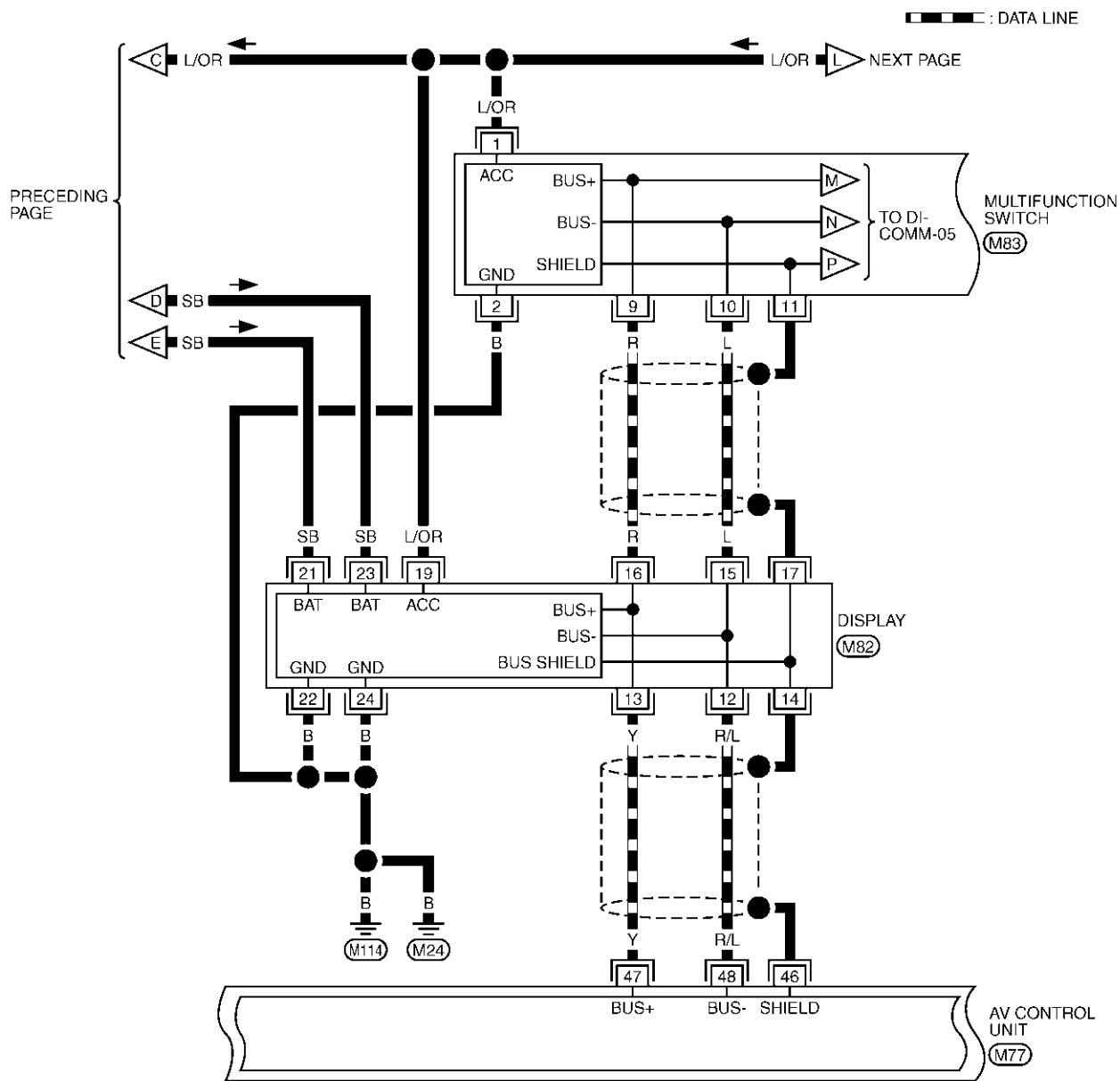

48	45	42	39	37	35	33	30	27
47	44	41	38	36	34	32	29	26
46	43	40				31	28	25

(M77) GY

24	22	20	18	16	14	10	8	6	4	2		
23	21	19	17	15	13	12	11	9	7	5	3	1

(M82) GY

20	18	16	14	12	8	6	4	2		
19	17	15	13	11	10	9	7	5	3	1

(M83) W

TKWM0296E

VEHICLE INFORMATION AND INTEGRATED SWITCH SYSTEM /WITHOUT NAVIGATION SYSTEM

DI-COMM-03

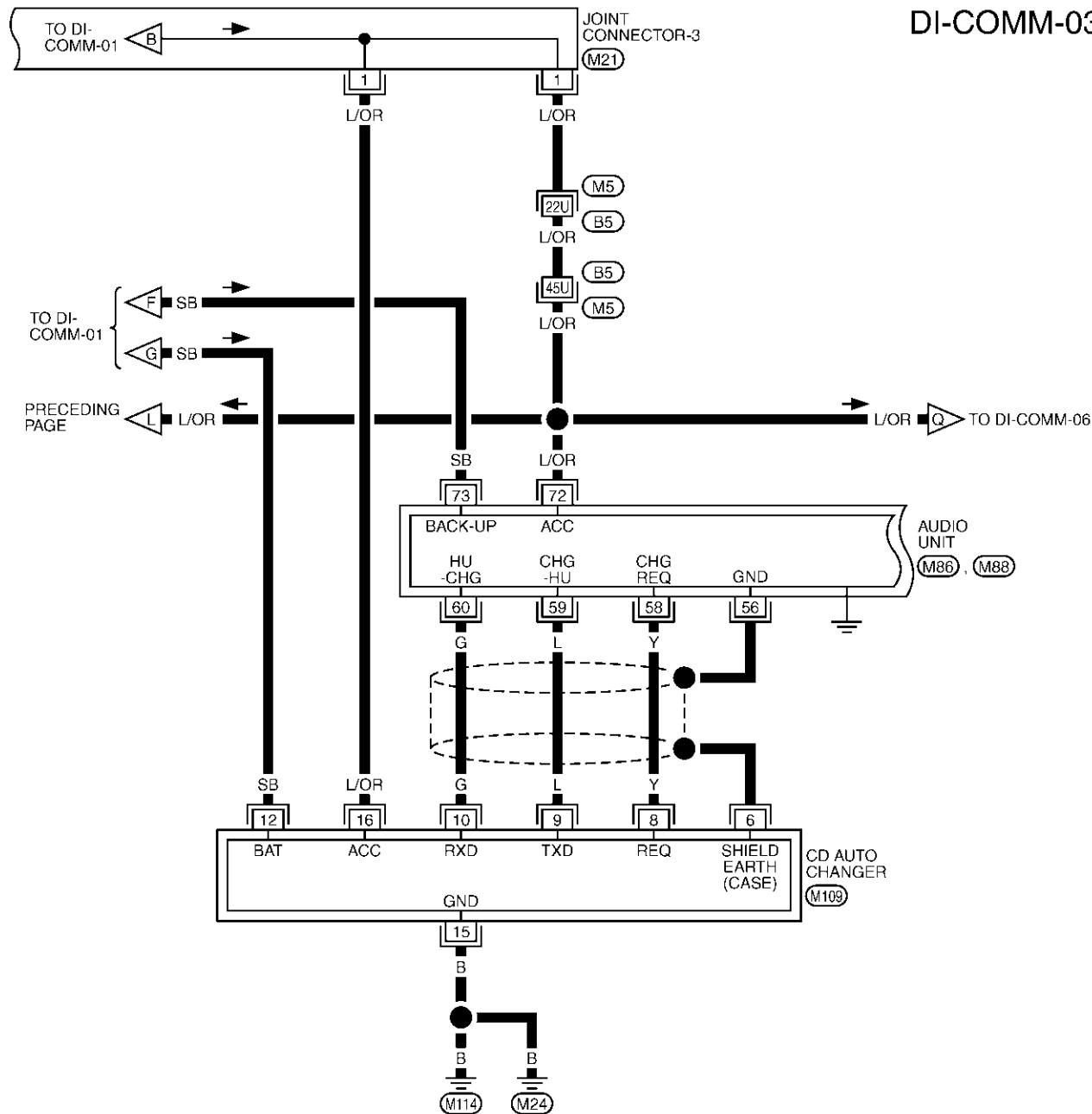

A
B
C
D
E
F
G
H
I
J
DI
L
M

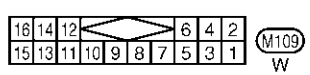
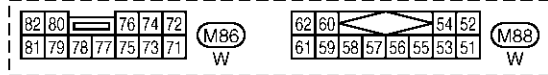
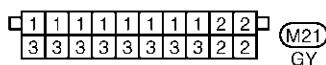

REFER TO THE FOLLOWING.
(M5) -SUPER MULTIPLE JUNCTION (SMJ)

TKWM0297E

VEHICLE INFORMATION AND INTEGRATED SWITCH SYSTEM /WITHOUT NAVIGATION SYSTEM

DI-COMM-04

▬ : DATA LINE

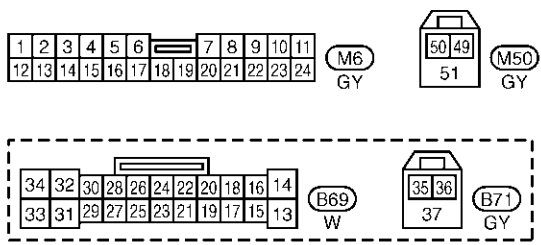
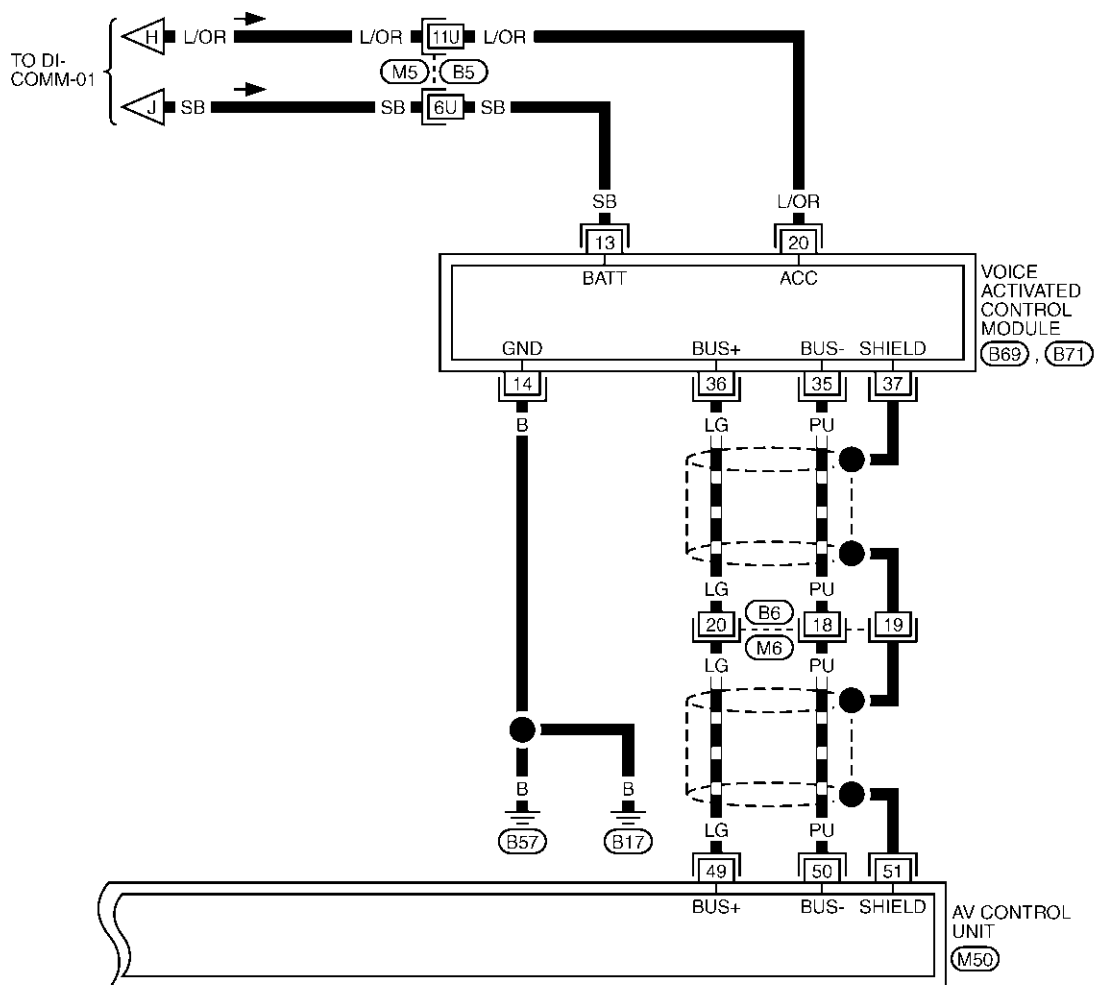

REFER TO THE FOLLOWING.

(M5) -SUPER MULTIPLE JUNCTION (SMJ)

TKWM0298E

VEHICLE INFORMATION AND INTEGRATED SWITCH SYSTEM /WITHOUT NAVIGATION SYSTEM

DI-COMM-05

A
B
C
D
E
F
G
H
I
J
DI
L
M

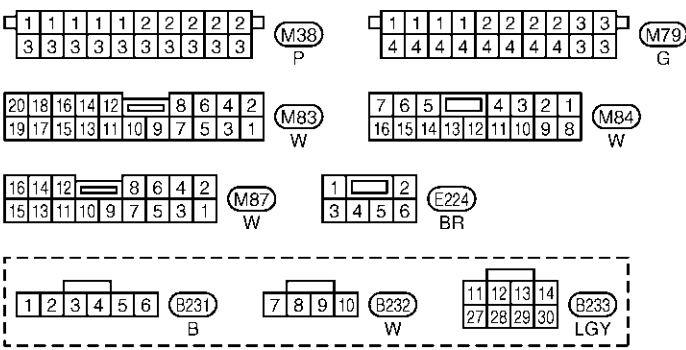
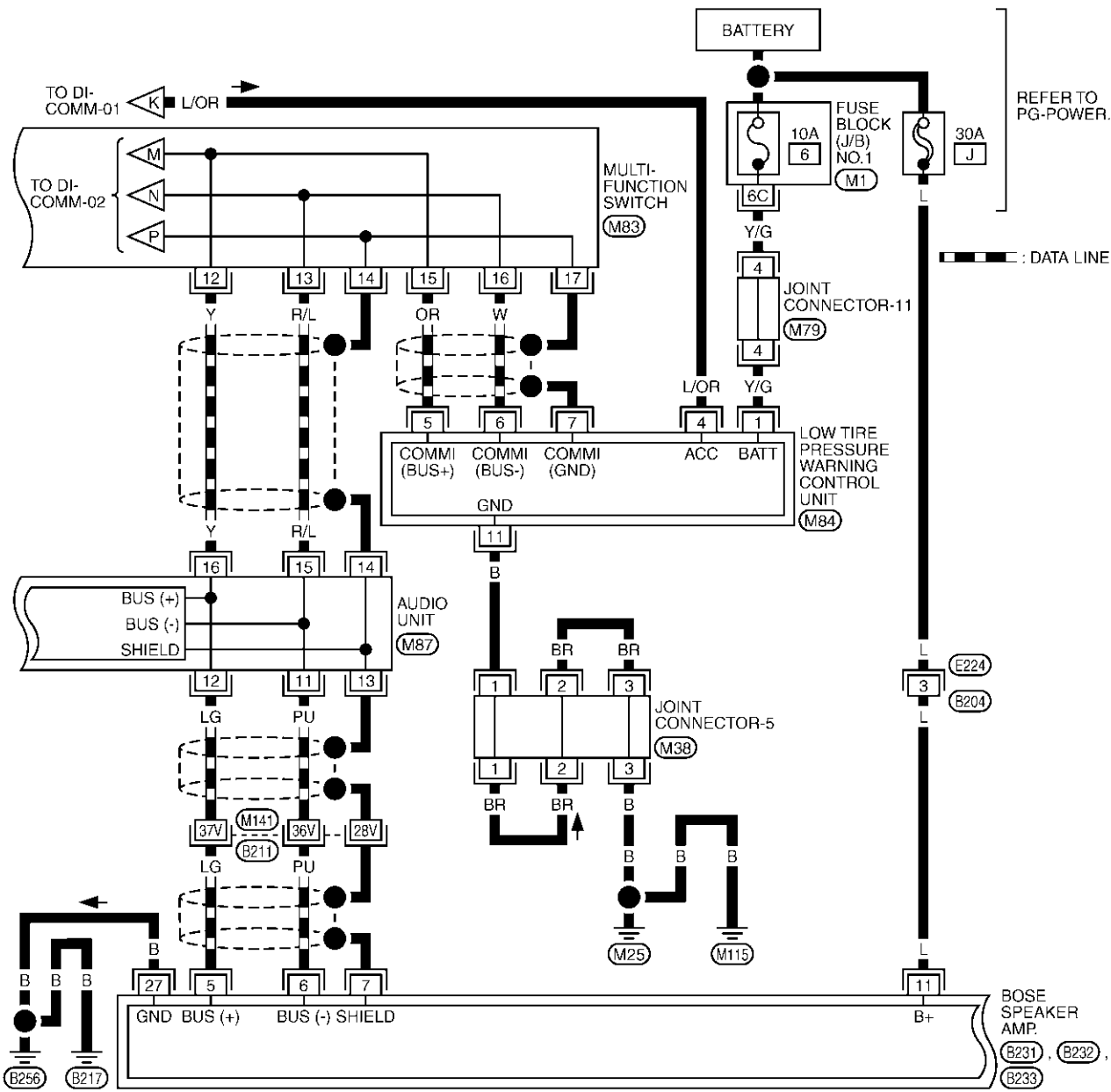

REFER TO THE FOLLOWING.

- (B211) -SUPER MULTIPLE JUNCTION (SMJ)
- (M1) -FUSE BLOCK-JUNCTION BOX (J/B) NO.1

TKWM0299E

VEHICLE INFORMATION AND INTEGRATED SWITCH SYSTEM /WITHOUT NAVIGATION SYSTEM

DI-COMM-06

▬ : DATA LINE

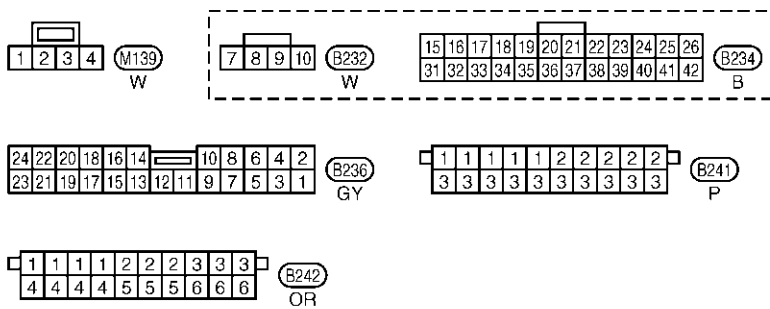
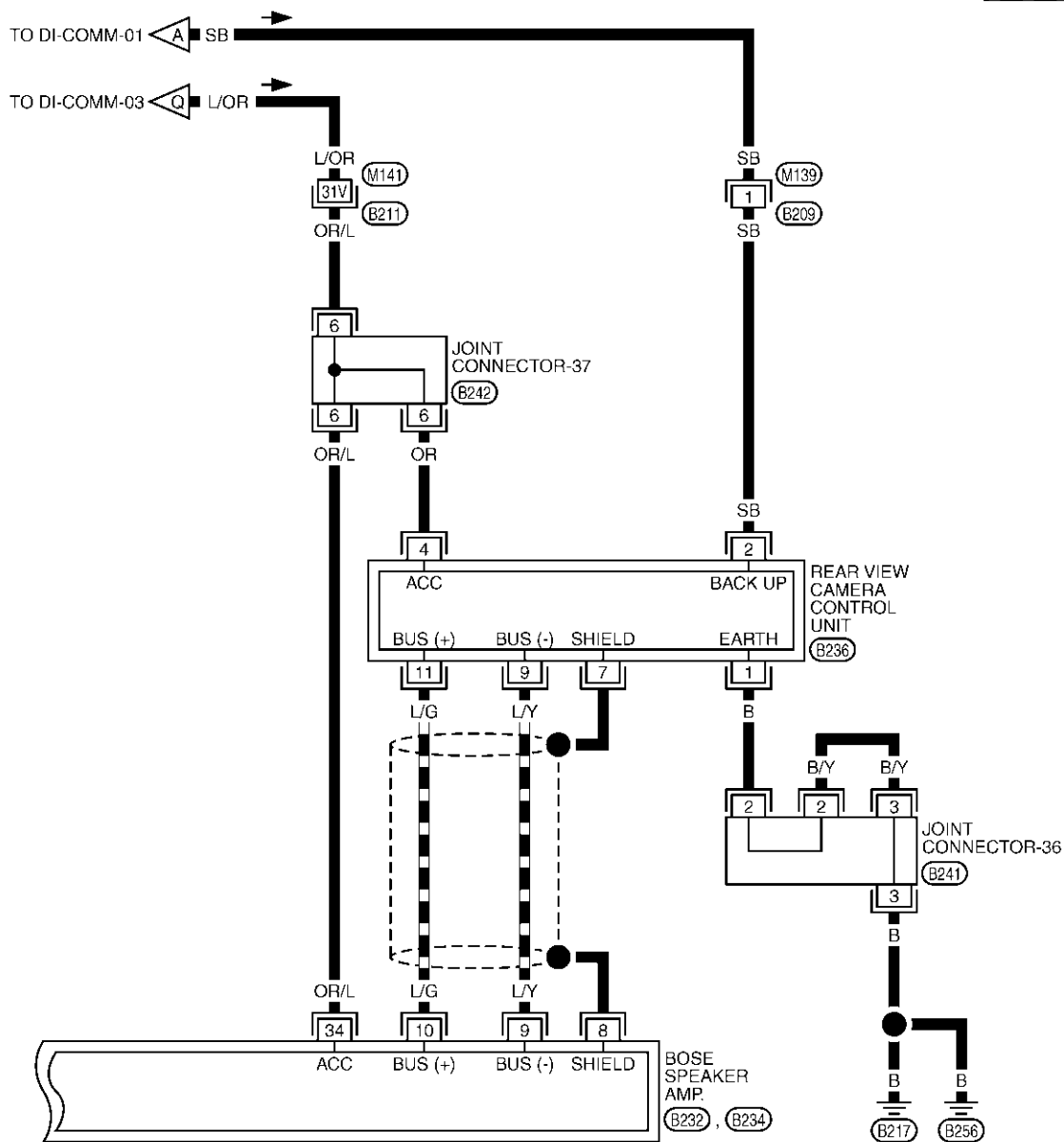

REFER TO THE FOLLOWING.

(B211) -SUPER MULTIPLE JUNCTION (SMJ)

TKWM0300E

VEHICLE INFORMATION AND INTEGRATED SWITCH SYSTEM /WITHOUT NAVIGATION SYSTEM

Terminals and Reference Value for AV Control Unit

EKS006DT

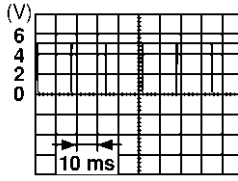
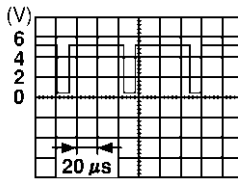
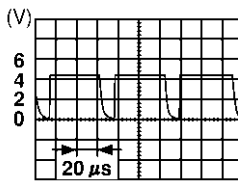
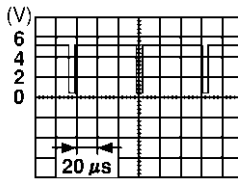
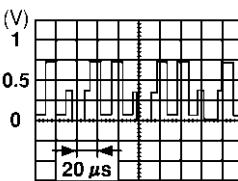
Terminals			Signal	Signal input/output	Condition		Reference value (V)	Example of symptom
(+)		(-)			Ignition switch	Operation		
Terminal No.	Wire color							
1	B	Ground	Ground	—	ON	—	Approx. 0	—
2	SB	Ground	Battery	Input	OFF	—	Battery voltage	System does not work properly.
3	SB							
4	B	Ground	Ground	—	ON	—	Approx. 0	—
6	L/OR	Ground	Ignition switch (ACC)	Input	ACC	—	Battery voltage	System does not work properly.
10	—	Ground	Shield Ground	—	ON	—	Approx. 0	—
11	OR	10	Vertical synchronizing signal	Input	ON	—	 <p style="text-align: right; font-size: small;">SKIA0161E</p>	Superimposed screen is rolling.
12	LG	10	RGB area signal	Output	ON	Press the "info" switch.	 <p style="text-align: right; font-size: small;">SKIA0162E</p>	RGB screen is not shown.
13	L/Y	10	Horizontal synchronizing signal	Input	ON	Adjust sound volume while rear-view screen is shown.	 <p style="text-align: right; font-size: small;">SKIA0163E</p>	RGB screen is not shown.
14	—	Ground	RGB ground	—	—	—	—	—
15	L/R	10	RGB synchronizing signal	Output	ON	Press the "MAP" switch.	 <p style="text-align: right; font-size: small;">SKIA0164E</p>	RGB screen is rolling.
18	L	14	RGB signal (R: red)	Output	ON	Select "SCREEN ADJUSTMENT" of CONFIRMATION/ADJUSTMENT function.	 <p style="text-align: right; font-size: small;">SKIA0165E</p>	RGB screen looks bluish.

VEHICLE INFORMATION AND INTEGRATED SWITCH SYSTEM /WITHOUT NAVIGATION SYSTEM

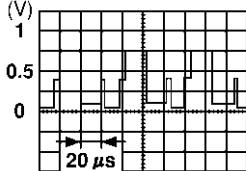
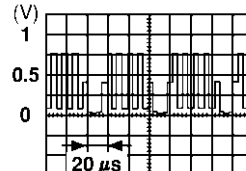
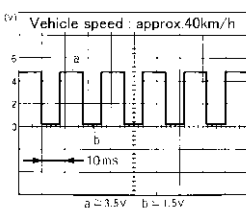
Terminals			Signal	Signal input/output	Condition		Reference value (V)	Example of symptom
(+)		(-)			Ignition switch	Operation		
Terminal No.	Wire color							
21	Y	14	RGB signal (G: green)	Output	ON	Select "SCREEN ADJUSTMENT" of CONFIRMATION/ADJUSTMENT function.	 <small>SKIA0166E</small>	RGB screen looks reddish.
24	G	14	RGB signal (B: blue)	Output	ON	Select "SCREEN ADJUSTMENT" of CONFIRMATION/ADJUSTMENT function.	 <small>SKIA0167E</small>	RGB screen looks yellowish.
25	L/Y	Ground	Illumination control signal	Input	ON	Optical sensor is exposed to light.	Approx. 3.5 or more	Screen does not switch between daytime mode and nighttime mode.
						Optical sensor is not exposed to light.	Approx. 1.5 or less	
27	BR/W	Ground	Ignition switch (ON)	Input	ON	—	Battery voltage	A/C operation is not possible. Vehicle information setting is not possible.
29	Y/R	Ground	Parking Brake signal	Input	ON	Parking brake pedal is depressed.	Approx. 1.5 or less	Vehicle running/stopped judgment is not correct.
						Parking brake pedal is not depressed.	Approx. 3.5 or more	
31	—	—	Shield ground	—	—	—	—	—
33	OR/L	Ground	Vehicle speed signal (8-pulse)	Input	ON	When vehicle speed is approx. 40 km/h (25 MPH)	 <small>SKIA0168E</small>	Vehicle electronic system does not indicate the correct position.

VEHICLE INFORMATION AND INTEGRATED SWITCH SYSTEM /WITHOUT NAVIGATION SYSTEM

Terminals			Signal	Signal input/output	Condition		Reference value (V)	Example of symptom
(+)		(-)			Ignition switch	Operation		
Terminal No.	Wire color							
34	LG	Ground	Communication signal (AV - ME)	Output	ON	Display the vehicle information screen.	 SKIA0169E	Vehicle information screen is not shown.
35	PU	Ground	Communication signal (ME - AV)	Input	ON	Perform various settings on the vehicle information screen.	 SKIA0170E	Vehicle information screen is not shown.
40	—	—	Shield ground	—	—	—	—	—
41	P	Ground	CONSULT-II communication signal (AV - CN)	Output	ON	Perform CONSULT-II.	 SKIA0169E	Diagnosis with CONSULT-II is not possible.
42	BR/Y	Ground	CONSULT-II communication signal (CN - AV)	Input	ON	Perform CONSULT-II.	 SKIA0170E	Diagnosis with CONSULT-II is not possible.
43	R	Ground	A/C communication signal (AV-AC)	Output	ON	—	 SKIA0172E	A/C operation is not possible.
44	W	Ground	A/C communication signal (AC-AV)	Input	ON	—	 SKIA0173E	A/C status is not indicated correctly.
45	B	Ground	A/C clock signal	Input	ON	—	 SKIA0174E	A/C status is not indicated correctly.

A
B
C
D
E
F
G
H
I
J
DI
L
M

VEHICLE INFORMATION AND INTEGRATED SWITCH SYSTEM /WITHOUT NAVIGATION SYSTEM

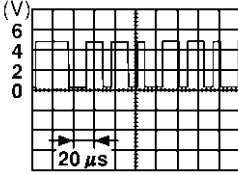
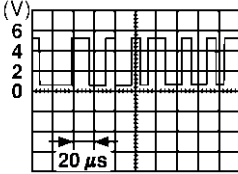
Terminals			Signal	Signal input/output	Condition		Reference value (V)	Example of symptom
(+)		(-)			Ignition switch	Operation		
Terminal No.	Wire color							
46	—	—	Shield ground	—	—	—	—	
47	Y	Ground	Communication signal (+)	Input/output	ON	—	 SKIA0175E	System does not work properly.
48	R/L	Ground	Communication signal (-)	Input/output	ON	—	 SKIA0176E	System does not work properly.

Terminals and Reference Value for Display

EKS006DU

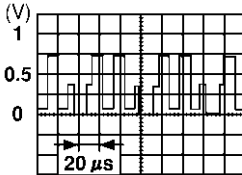
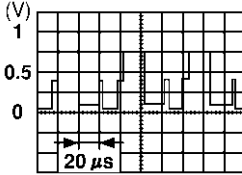
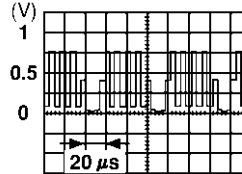
Terminals			Signal	Condition		Reference value (V)
(+)		(-)		Ignition switch	Operation	
Terminal No.	Wire color					
1	L	Ground	RGB signal (R: Red)	ON	Move to "Screen Adjustment" in the check/adjustment function.	 SKIA0165E
2	Y	Ground	RGB signal (G: Green)	ON	Move to "Screen Adjustment" in the check/adjustment function.	 SKIA0166E
3	G	Ground	RGB signal (B: Blue)	ON	Move to "Screen Adjustment" in the check/adjustment function.	 SKIA0167E
4	—	Ground	RGB ground	ON	—	Approx. 0

VEHICLE INFORMATION AND INTEGRATED SWITCH SYSTEM /WITHOUT NAVIGATION SYSTEM

Terminals			Signal	Condition		Reference value (V)
(+)		(-)		Ignition switch	Operation	
Terminal No.	Wire color					
5	L/Y	Ground	Horizontal synchronizing signal	ON	ON screen, the volume can be adjusted.	<p style="text-align: right; font-size: small;">SKIA0163E</p>
6	OR	Ground	Vertical synchronizing signal	ON	—	<p style="text-align: right; font-size: small;">SKIA0161E</p>
7	L/R	Ground	RGB synchronizing signal	ON	Press the map switch.	<p style="text-align: right; font-size: small;">SKIA0164E</p>
8	LG	Ground	RGB area signal	ON	Press the vehicle information switch.	<p style="text-align: right; font-size: small;">SKIA0162E</p>
12	R/L	Ground	Communication signal (-)	ON	—	<p style="text-align: right; font-size: small;">SKIA0176E</p>
13	Y	Ground	Communication signal (+)	ON	—	<p style="text-align: right; font-size: small;">SKIA0175E</p>
14	—	—	Shield ground	—	—	—
15	L	Ground	Communication signal (-)	ON	—	<p style="text-align: right; font-size: small;">SKIA0176E</p>

A
B
C
D
E
F
G
H
I
J
DI
L
M

VEHICLE INFORMATION AND INTEGRATED SWITCH SYSTEM /WITHOUT NAVIGATION SYSTEM

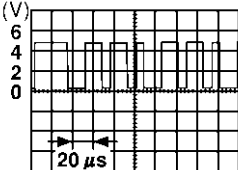
Terminals			Signal	Condition		Reference value (V)
(+)		(-)		Ignition switch	Operation	
Terminal No.	Wire color					
16	R	Ground	Communication signal (+)	ON	—	 SKIA0175E
17	—	Ground	Shield ground	—	—	—
19	L/OR	Ground	Ignition switch (ACC)	ACC	—	Battery voltage
21	SB	Ground	Battery power	OFF	—	Battery voltage
23	SB					
22	B	Ground	Ground	—	—	—
24	B					

Terminals and Reference Value for Multifunction Switch

EKS006DV

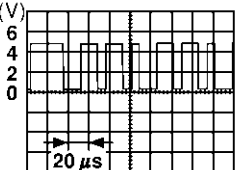
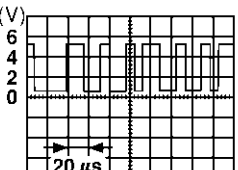
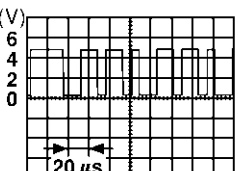
Terminals			Signal	Condition		Reference value
(+)		(-)		Ignition switch	Operation	
Terminal No.	Wire color					
1	L/OR	Ground	Ignition switch (ACC)	ACC	—	Battery voltage
2	B	Ground	Ground	ON	—	Approx. 0V
9	R	Ground	Communication signal (+)	ON	—	 SKIA0175E
10	L	Ground	Communication signal (-)	ON	—	 SKIA0176E
11	—	Ground	Shield ground	ON	—	—
15	OR	Ground	Communication signal (+)	ON	—	 SKIA0175E

VEHICLE INFORMATION AND INTEGRATED SWITCH SYSTEM /WITHOUT NAVIGATION SYSTEM

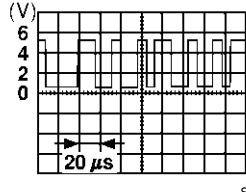
Terminals			Signal	Condition		Reference value
(+)		(-)		Ignition switch	Operation	
Terminal No.	Wire color					
16	W	Ground	Communication signal (-)	ON	—	
17	—	Ground	Shield ground	—	—	—

A
B
C
D
E
F
G
H
I
J
DI
L
M

DI

VEHICLE INFORMATION AND INTEGRATED SWITCH SYSTEM /WITHOUT NAVIGATION SYSTEM

On Board Self-Diagnosis Function (without CONSULT-II)

EKS006QY

DESCRIPTION

- Diagnosis function consists of the self-diagnosis mode performed automatically and the CONFIRMATION/ADJUSTMENT mode operated manually.
- Self-diagnosis mode checks for connections between the units constituting this system, analyzes each individual unit at the same time, and displays the results on the LCD screen.
- CONFIRMATION/ADJUSTMENT mode is used to perform trouble diagnosis that require operation and judgment by an operator (malfunction that cannot be automatically judged by the system), to check/change the set value, and to display the History of Errors of the navigation system.

DIAGNOSIS ITEM

Mode		Description
Self-diagnosis		<ul style="list-style-type: none"> ● AV control unit diagnosis (DVD-ROM drive will not be diagnosed when no map DVD-ROM is in it.). ● Analyzes connection between the AV control unit and the GPS antenna, connection between the AV control unit and each unit, and operation of each unit.
CONFIRMATION/ ADJUSTMENT	Display Diagnosis	Color tone and shading of the screen can be checked by the display of a color bar and a gray scale.
	Vehicle Signals	Analyzes the following vehicle signals: Vehicle speed signal, parking brake signal, light signal, ignition switch signal, and reverse signal.
	Speaker Test	Checks the connection of each speaker using a test tone.
	Auto Climate Control	Turns all A/C screens on display and A/C switch indicator lamp on.
	Rear View Camera	Changes position of the aiming line overlapped on the rear view image.

VEHICLE INFORMATION AND INTEGRATED SWITCH SYSTEM /WITHOUT NAVIGATION SYSTEM

EKS006QZ

Self-Diagnosis Mode OPERATION PROCEDURE

1. Start the engine.
2. Turn the audio system off.
3. While pressing the "INFO" switch, turn the volume control dial clockwise or counterclockwise for 30 clicks or more. (When the self-diagnosis mode is started, a short beep will be heard.)
 - Shifting from current screen to previous screen is performed by pressing "PREV" switch.

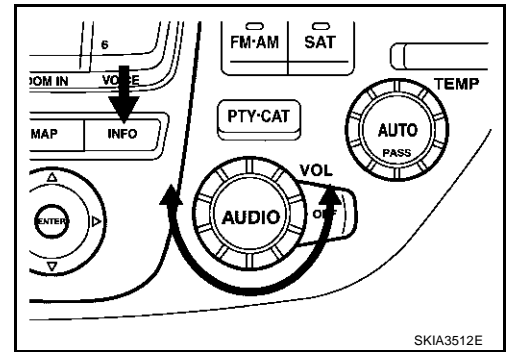

4. The initial trouble diagnosis screen will be shown, and items "SELF DIAGNOSIS" and "Confirmation/Adjustment" will become selective.

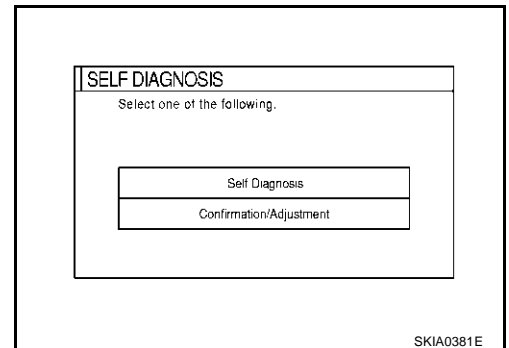

5. Perform self-diagnosis by selecting the "SELF DIAGNOSIS".
 - Self-diagnosis subdivision screen will be shown and the operation enters the self-diagnosis mode.
 - A bar graph shown below the self-diagnosis subdivision screen indicates progress of the diagnosis.

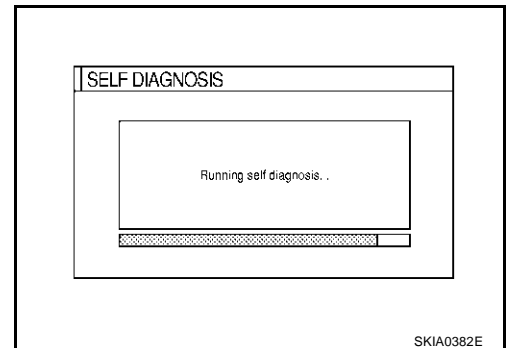

6. When the self-diagnosis completes, optional part confirmation screen will be shown.
 - When connection of an optional part is judged poor, a screen to check if the optional part is actually fitted on the vehicle or not will be shown. When fitted, select the switch of the part on the screen and press "END". Then the "SELF DIAGNOISIS" screen will be shown.
 - When the optional part is connected normally, the switch for the part will not appear on the screen.

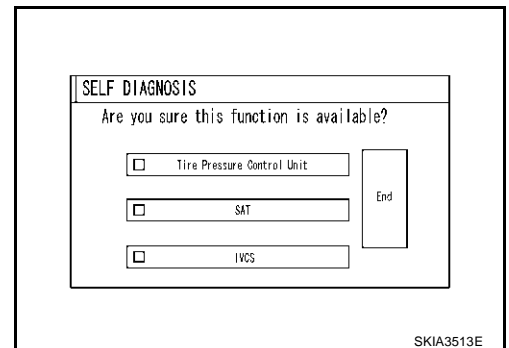

A
B
C
D
E
F
G
H
I
J
DI
L
M

VEHICLE INFORMATION AND INTEGRATED SWITCH SYSTEM /WITHOUT NAVIGATION SYSTEM

7. On the "SELF DIAGNOSIS" screen, each unit name will be colored according to the diagnosis result, as follows.

Green : No malfunctioning.

Yellow : Cannot be judged by self-diagnosis results.

Red : Unit is malfunctioning.

- If several malfunctions are present in a unit, color of its switch on the screen will be either red or yellow determined by the malfunction of the highest priority.

CAUTION:

"Tire Pressure Control Unit" on the screen will be illuminated in yellow when performing self-diagnosis with ignition switch in ACC position.

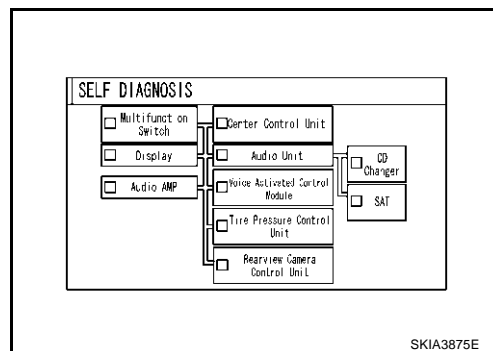

8. Select a switch on the "SELF DIAGNOSIS" screen and comments for the diagnosis results will be shown.

- When the switch is green, the following comment will be shown. "Self-diagnosis was successful. Further diagnosis and adjustments are recommended. Follow the "confirmation and adjustments" menu or refer to the service manual."
- When the switch is yellow, the following comment will be shown. "Connection to the following unit is abnormal. See the Service Manual for further details".
- When the switch is red, the following comment will be shown. "Center Control Unit is abnormal".

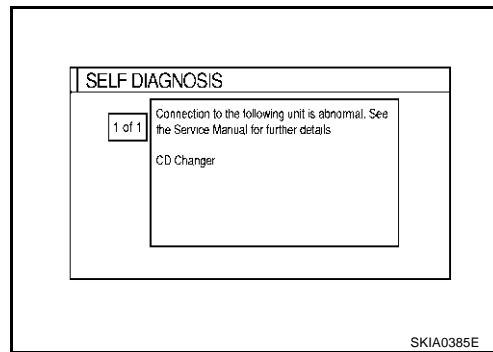

VEHICLE INFORMATION AND INTEGRATED SWITCH SYSTEM /WITHOUT NAVIGATION SYSTEM

SELF-DIAGNOSIS RESULT

Quick reference table

1. Select an applicable diagnosis No. in the diagnosis result quick reference table.
2. Find estimated malfunctioning system in the diagnosis No. table and perform check by referring to [DI-95, "Wiring Diagram — COMM —"](#).
3. Turn the ignition switch to OFF and perform self-diagnosis again.

Screen switch									Diagnosis No.
Switch color	Center control unit* ¹	Display	Tire pressure control unit	Audio unit	CD auto changer	Audio amp.* ²	Rearview Camera Control Unit	Voice activated control module	
Red	×								1
Yellow	×	×							2
	×		×						3
	×			×	×				4
	×				×				5
	×					×			6
	×						×		7
	×							×	8
	×						×	×	9
	×				×	×	×	×	10

- *1: Center control unit = AV control unit
- *2: Audio amp. = BOSE speaker amp.

CAUTION:

- **When multifunction switch has a malfunction, you cannot start.**
- **Check the following when the self-diagnosis mode you cannot use.**
 - AV communication line between AV control unit and Display, AV communication line between Display and multifunction switch.
 - multifunction switch power supply and ground circuit
- **When an error is in the AV communication line, it cannot be detected on the screen because self-diagnosis is inoperative. However, the error can be detected with CONSULT-II.**

VEHICLE INFORMATION AND INTEGRATED SWITCH SYSTEM /WITHOUT NAVIGATION SYSTEM

Self-diagnosis codes

Diagnosis No.	Possible cause
1	AV control unit malfunction
2	Display power supply and ground circuit
3	<ul style="list-style-type: none">● Low tire pressure warning control unit power supply and ground circuit,● AV communication line between low tire pressure warning control unit and multifunction switch.
4	Audio unit power supply and ground circuit
5	<ul style="list-style-type: none">● CD auto changer power supply and ground circuit● AV communication line between CD auto changer and audio unit.
6	BOSE speaker amp. power supply and ground circuit.
7	Rear view camera control unit power supply and ground circuit.
8	Voice activated control module power supply and ground circuit.
9	<ul style="list-style-type: none">● AV communication line between BOSE speaker amp. and audio unit.● BOSE speaker amp. internal communication circuit.
10	<ul style="list-style-type: none">● AV communication line between audio unit and multifunction switch.● Audio control unit communication circuit.

VEHICLE INFORMATION AND INTEGRATED SWITCH SYSTEM /WITHOUT NAVIGATION SYSTEM

Confirmation/Adjustment Mode

OPERATION PROCEDURE

1. Start the engine.
2. Turn the audio system off.
3. While pressing the "INFO" switch, turn the volume control dial clockwise or counterclockwise for 30 clicks or more. (When the self-diagnosis mode is started, a short beep will be heard.)
 - Shifting from current screen to previous screen is performed by pressing "PREV" switch.

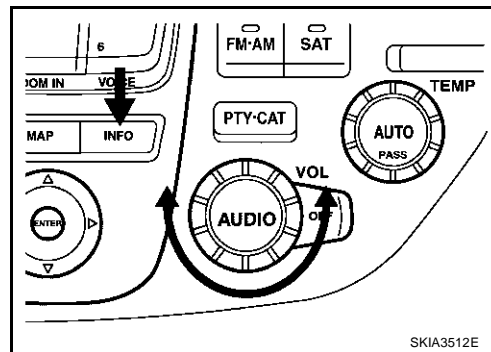

4. The initial trouble diagnosis screen will be shown, and items "SELF DIAGNOSIS" and "Confirmation/Adjustment" will become selective.

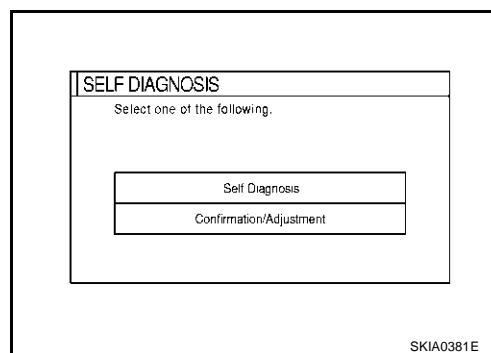

5. When "Confirmation/Adjustment" is selected on the initial trouble diagnosis screen, the operation will enter the CONFIRMATION/ADJUSTMENT mode. In this mode, check and adjustment of each item will become possible.
6. Select each switch on "Confirmation/Adjustment" screen to display the relevant diagnosis screen.

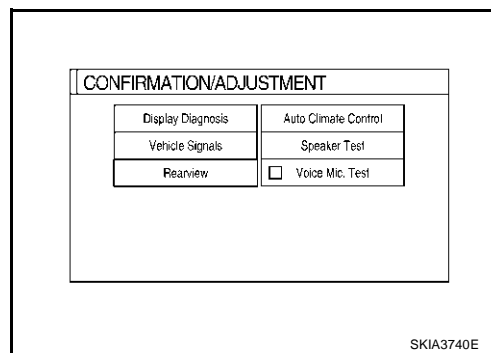

VEHICLE INFORMATION AND INTEGRATED SWITCH SYSTEM /WITHOUT NAVIGATION SYSTEM

DISPLAY DIAGNOSIS

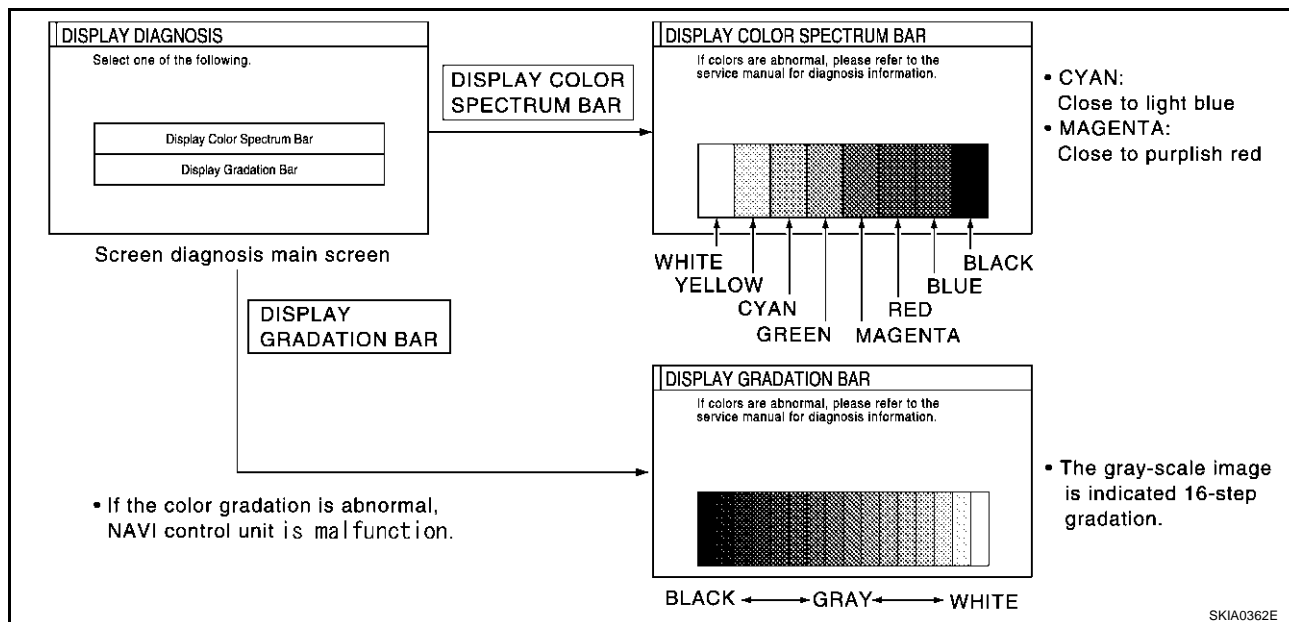

CAUTION:

When **DISPLAY COLOR SPECTRUM BAR** screen is completed after "PREV" switch is pressed, the screen color changes once. This is normal.

- When RGB signal error occurred in the RGB system, tone of the color bar will change as follows.
 - R (red) signal error** : Screen looks bluish
 - G (green) signal error** : Screen looks yellowish
 - B (blue) signal error** : Screen looks reddish
- When the color of the screen looks unusual, refer to [DI-124, "Color of RGB Image is not Proper"](#) .

VEHICLE INFORMATION AND INTEGRATED SWITCH SYSTEM /WITHOUT NAVIGATION SYSTEM

VEHICLE SIGNALS

- A comparison check can be made of each actual vehicle signal and the signals recognized by the system.

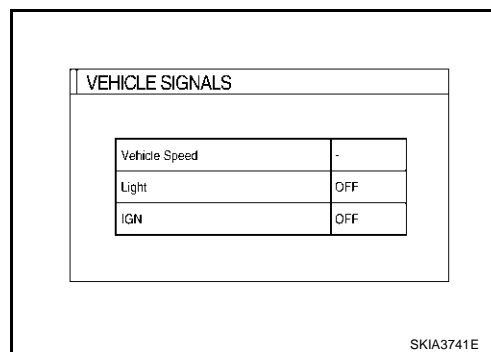

Diagnosis item	Display	Condition	Remarks
Vehicle Speed	ON	Vehicle speed > 0 km/h (0 MPH)	Changes in indication may be delayed by approx. 1.5 seconds. This is normal.
	OFF	Vehicle speed = 0 km/h (0 MPH)	
	-	Ignition switch in ACC position	
Light	ON	Lighting switch ON	-
	OFF	Lighting switch OFF	
IGN	ON	Ignition switch ON	-
	OFF	Ignition switch ACC or OFF	

- If vehicle speed is NG, refer to [DI-122, "Vehicle Speed Signal Inspection"](#) .
- If light is NG, refer to [DI-123, "Illumination Control Signal Inspection"](#) .
- If IGN is NG, refer to [DI-123, "Ignition Signal Inspection"](#) .

SPEAKER TEST

- Refer to [AV-26, "Confirmation/Adjustment Mode \(without navigation system\)"](#) for the details.

AUTO CLIMATE CONTROL

- Refer to [ATC-53, "Self-diagnosis Function"](#) in ATC section for the details.

REARVIEW CAMERA

- Refer to [DI-174, "Confirmation/Adjustment Mode"](#) for the details.

VEHICLE INFORMATION AND INTEGRATED SWITCH SYSTEM /WITHOUT NAVIGATION SYSTEM

CONSULT-II Function

EKS006R1

CONSULT-II BASIC OPERATION PROCEDURE

1. With the ignition switch OFF, connect "CONSULT-II" and "CONSULT-II CONVERTER" to the data link connector, and turn the ignition switch ON.

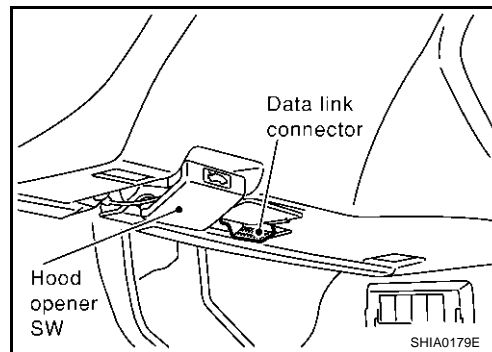

2. Touch "START(NISSAN BASED VHCL)".

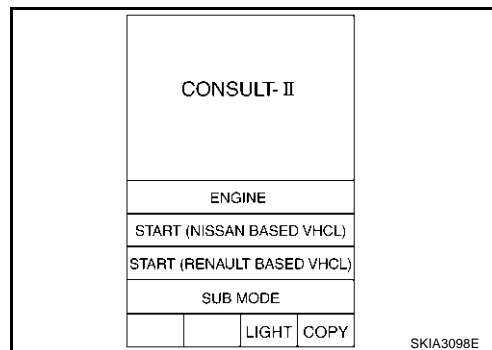

3. Touch "MULTIAV".
If "MULTIAV" is not indicated, go to [GI-38, "CONSULT-II Data Link Connector \(DLC\) Circuit"](#).
4. Select "VIRSION", "SELF-DIAG RESULTS" or "SIGNAL MONITOR".

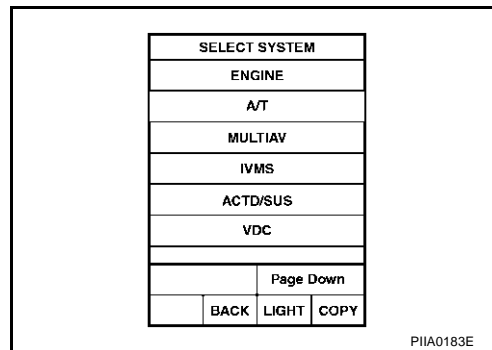

VEHICLE INFORMATION AND INTEGRATED SWITCH SYSTEM /WITHOUT NAVIGATION SYSTEM

SELF-DIAG RESULTS

- Checks for connection between each unit and analyzes each individual unit, then displays the results on the screen.

Items shown

Items shown	Malfunctioning part/reference page
NO DTC IS DETECTED. FURTHER TESTING MAY BE REQUIRED.	-
HEAD UNIT ABNORMAL	AV control unit malfunction
PANEL SW ABNORMAL CONNECTION	Refer to DI-111, "Quick reference table" .
AUDIO HEAD UNIT ABNORMAL CONNECTION	Refer to DI-111, "Quick reference table" .
AIR COMP RECEIVER ABNORMAL CONNECTION	Refer to DI-111, "Quick reference table" .
BOSE AMP ABNORMAL CONNECTION	Refer to DI-111, "Quick reference table" .
BOSE AMP ABNORMAL	BOSE speaker amp. malfunction
VOICE UNIT ABNORMAL CONNECTION	Refer to DI-111, "Quick reference table" .
VOICE UNIT ABNORMAL	Voice activated control module malfunction
REARVIEW CAMERA ABNORMAL CONNECTION	Refer to DI-111, "Quick reference table" .
PANEL SW ABNORMAL CONNECTION (MULTIFUNCTION SW)	Refer to DI-111, "Quick reference table" .

NOTE:

When "IVCS ABNORMAL CONNECTION" is indicated, it does not malfunction.

DATA MONITOR

- Displays status of the vehicle signal input to the AV control unit. (Refer to [DI-113, "Confirmation/Adjustment Mode"](#) for operation conditions for the connections to be indicated.)

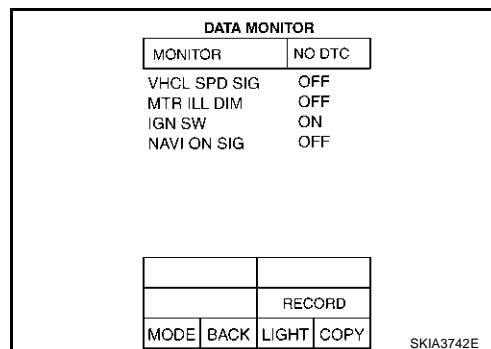

- For each signal, a comparison of actual operating status and the status recognized by the system can be checked.

DATA MONITOR item	Display	Condition	Remarks
VHCL SPD SIG	ON	Vehicle speed >0 km/h (0 MPH)	Changes in indication may be delayed by approx. 1.5 seconds. This is normal.
	OFF	Vehicle speed =0 km/h (0 MPH)	
	-	Ignition switch in ACC position	
MTR ILL DIM	ON	Lighting switch ON	-
	OFF	Lighting switch OFF	
IGN SW	ON	Ignition switch ON	-
	OFF	Ignition switch ACC or OFF	
NAVI ON SIG	OFF	-	This item cannot be monitored. (No change of display)

VEHICLE INFORMATION AND INTEGRATED SWITCH SYSTEM /WITHOUT NAVIGATION SYSTEM

VERSION

Displays version of each unit connected to the AV control unit.

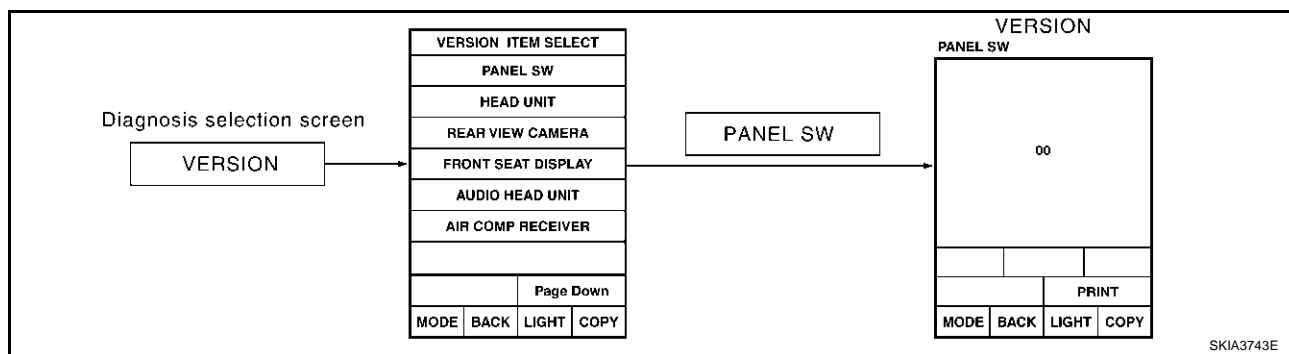

Version display	Remarks
"PANEL SW"	Multifunction switch
"HEAD UNIT"	AV control unit
"REAR VIEW CAMERA"	-
"FRONT SEAT DISPLAY"	Display
"AUDIO HEAD UNIT"	-
"AIR COMP RECEIVER"	Low Tire Pressure Warning Control Unit
"BOSE AMP"	-
"IVCS"	-
"VOICE UNIT"	Voice Activated Control Module

Multifunction Switch Self-Diagnosis Function

EKS006E0

It can check ON/OFF operation of each switch in the multifunction switch and diagnose the input signals to the rear control switch (audio) and steering switch (audio).

STARTING THE SELF-DIAGNOSIS MODE

1. Turn ignition switch from OFF to ACC.
2. Within 10 seconds press and hold the function switches "1" and "6" simultaneously for 5 seconds.

Then the self-diagnosis operates.

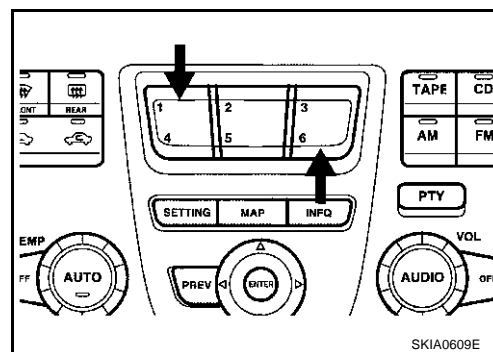

EXITING THE SELF-DIAGNOSIS MODE

- Turn ignition switch OFF, or press and hold the function switches "1" and "6" simultaneously for 5 seconds. Then the self-diagnosis ends.

DIAGNOSIS FUNCTION

- It can illuminate all the indicators (LED) in the multifunction switch.
- It can check for continuity of the switches by sounding the buzzer when the multifunction switch is pressed.
- It can check for continuity of harness between multifunction switch and rear control switch (audio), or steering switch (audio).

NOTE:

When it check continuity of harness between multifunction switch and rear control switch (audio), rear control cancel switch is OFF position.

VEHICLE INFORMATION AND INTEGRATED SWITCH SYSTEM /WITHOUT NAVIGATION SYSTEM

Power Supply and Ground Circuit Inspection for AV Control Unit

EKS006E1

1. CHECK FUSE

Check AV control unit fuses are not blown.

Unit	Power source	Fuse No.
AV control unit	Battery power	47
	Ignition switch ACC or ON	21

OK or NG

OK >> GO TO 2.

NG >> If fuse is blown, be sure to eliminate cause of malfunction before installing new fuse. Refer to [PG-2, "POWER SUPPLY ROUTING"](#).

2. CHECK POWER SUPPLY CIRCUIT

1. Disconnect AV control unit connector.
2. Check voltage between AV control unit and ground.

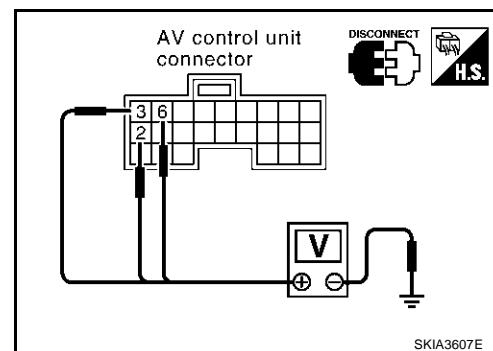

Terminals		Ignition switch position			
Connector	Terminal (Wire color)	(-)	OFF	ACC	ON
			(+)		
M78	2 (SB)	Ground	Battery voltage	Battery voltage	Battery voltage
	3 (SB)	Ground	Battery voltage	Battery voltage	Battery voltage
	6 (L/OR)	Ground	0V	Battery voltage	Battery voltage

OK or NG

OK >> GO TO 3.

NG >> Check harness for open or short between AV control unit and fuse.

3. CHECK GROUND CIRCUIT

Check continuity between AV control unit harness connector M78 terminal 1 (B), 4 (B) and ground.

Continuity should exist.

OK or NG

OK >> Inspection end.

NG >> Repair harness or connector.

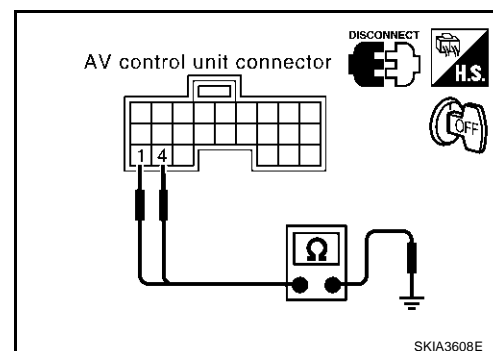

VEHICLE INFORMATION AND INTEGRATED SWITCH SYSTEM /WITHOUT NAVIGATION SYSTEM

EKS006E2

Power Supply and Ground Circuit Inspection for Display

1. CHECK FUSES

- Check 15A fuse [No. 52, located in fuse, fusible link and relay block (J/B)] is blown.
- Check 10A fuse [No. 21, located in fuse block (J/B) No. 1] is blown.

OK or NG

OK >> GO TO 2.

NG >> If fuse is blown, be sure to eliminate cause of malfunction before installing new fuse. Refer to [PG-2, "POWER SUPPLY ROUTING"](#).

2. CHECK POWER SUPPLY CIRCUIT

1. Disconnect display connector.
2. Check voltage between display connector M82 terminals 19 (L/OR), 21 (SB), 23 (SB) and ground.

Terminals		Ignition switch position			
(+)		(-)	OFF	ACC	ON
Connector	Terminal (Wire color)				
M82	19 (L/OR)	Ground	0V	Battery voltage	Battery voltage
	21 (SB)	Ground	Battery voltage	Battery voltage	Battery voltage
	23 (SB)	Ground	Battery voltage	Battery voltage	Battery voltage

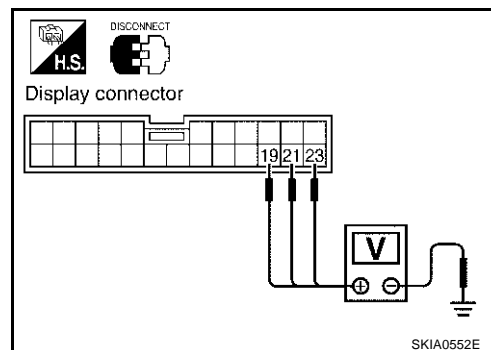

OK or NG

OK >> GO TO 3.

NG >> Check harness for open or short between display and fuse.

3. CHECK GROUND CIRCUIT

Check continuity between display connector M82 terminal 22, 24 and ground.

Terminals		(-)	Continuity
(+)			
Connector	Terminal (Wire color)		
M82	22 (B)	Ground	Yes
M82	24 (B)	Ground	Yes

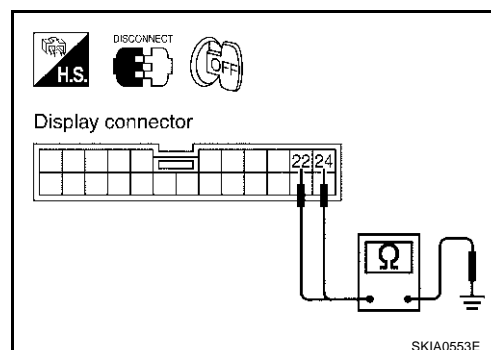

OK or NG

OK >> Inspection end.

NG >> Repair harness or connector.

VEHICLE INFORMATION AND INTEGRATED SWITCH SYSTEM /WITHOUT NAVIGATION SYSTEM

Inspection of Multifunction Switch for Power Supply and Ground Circuit

EKS006E3

1. CHECK POWER SUPPLY CIRCUIT

1. Disconnect multifunction switch connector.
2. Check voltage between multifunction switch harness connector M83 terminal 1 (L/OR) and ground.

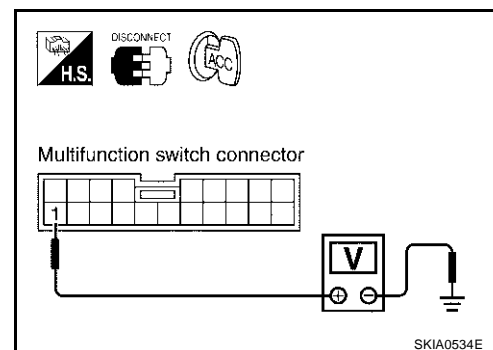

Terminals		Ignition switch position			
Connector	(+)	(-)	OFF	ACC	ON
	Terminal (Wire color)				
M83	1 (L/OR)	Ground	0V	Battery voltage	Battery voltage

OK or NG

OK >> GO TO 3.

NG >> Check harness for open or short between multifunction switch and fuse.

2. CHECK GROUND CIRCUIT

Check continuity between multifunction switch harness connector M83 terminal 2 (B) and ground.

Continuity should exist.

OK or NG

OK >> Inspection end.

NG >> Repair harness or connector.

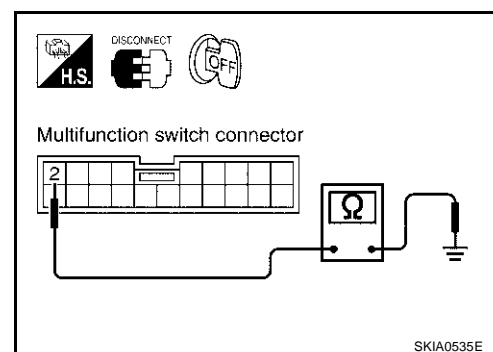

A
B
C
D
E
F
G
H
I
J
DI
L
M

VEHICLE INFORMATION AND INTEGRATED SWITCH SYSTEM /WITHOUT NAVIGATION SYSTEM

EKS006E4

Vehicle Speed Signal Inspection

1. CHECK HARNESS

1. Disconnect AV control unit and combination meter connector.
2. Check continuity between AV control unit harness connector M77 terminal 33 (OR/L) and ground.

Continuity should not exist.

3. Check continuity between AV control unit harness connector M77 terminal 33 (OR/L) and combination meter harness connector M41 terminal 17 (OR/L).

Continuity should exist.

OK or NG

OK >> GO TO 2.

NG >> ● Check connector housings for disconnected or loose terminals.

- Repair harness or connector.

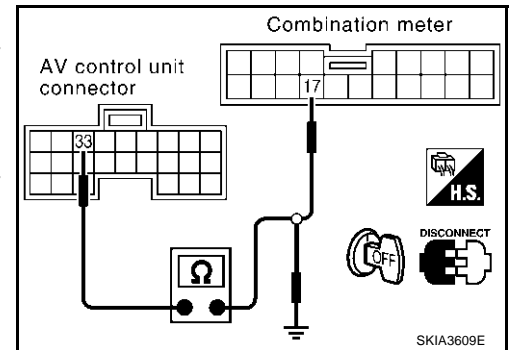

2. VEHICLE SPEED SIGNAL CHECK 1

1. Connect AV control unit connector.
2. Check voltage between AV control unit harness connector M77 terminal 33 (OR/L) and ground.

Approx. 3.5V or more

OK or NG

OK >> GO TO 3.

NG >> Replace AV control unit.

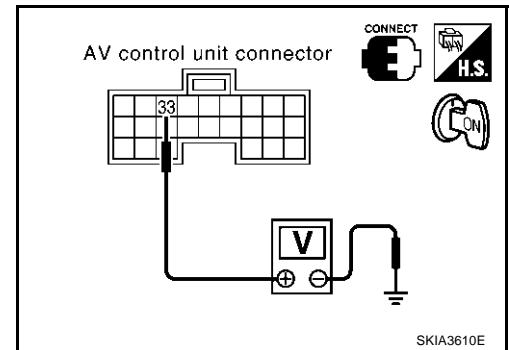

3. VEHICLE SPEED SIGNAL CHECK 2

1. Connect combination meter connector.
2. Start engine and drive vehicle at more than 40 km/h (25 MPH).
3. Check signal between AV control unit harness connector M77 terminal 33 (OR/L) and ground.

33 (OR/L) - Ground : Refer to [DI-101, "Terminals and Reference Value for AV Control Unit"](#) .

OK or NG

OK >> Replace AV control unit.

NG >> Check combination meter. Refer to [DI-23, "Inspection/Vehicle Speed Signal"](#) .

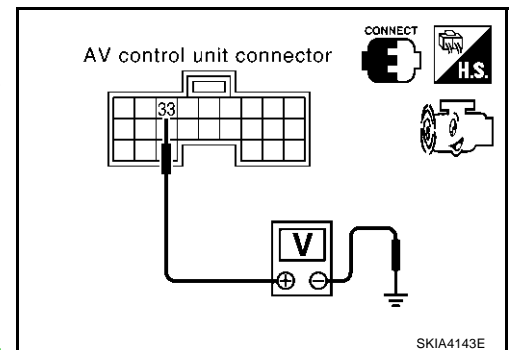

Illumination Control Signal Inspection

EKS006E5

1. CHECK ILLUMINATION CONTROL SIGNAL

1. Turn ignition switch ON.
2. Check voltage between AV control unit and ground.

Terminals			Lighting switch condition	Voltage (V)
(+)		(-)		
Connector	Terminal (Wire color)			
M77	25 (L/Y)	Ground	1st or 2nd position	Approx. 3.5 or more
			OFF	Less than approx. 1.5

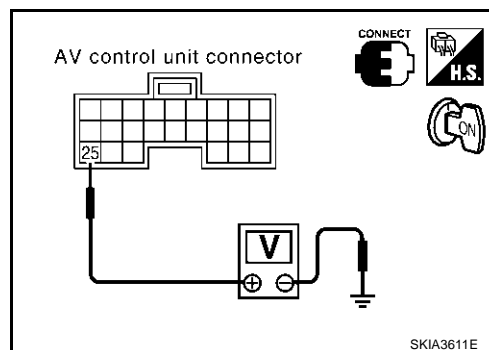

OK or NG

- OK >> Replace AV control unit.
 NG >> Check harness for open or short between AV control unit and BCM.

Ignition Signal Inspection

EKS006E6

1. CHECK IGNITION SIGNAL

1. Disconnect AV control unit connector.
2. Check voltage between AV control unit and ground.

Terminals			Ignition switch position		
(+)		(-)	OFF	ACC	ON
Connector	Terminal (wire color)				
M77	27 (BR/W)	Ground	0V	0V	Battery voltage

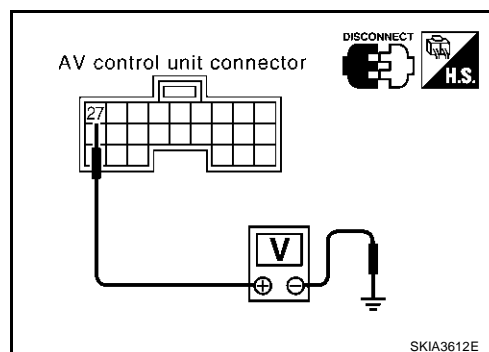

OK or NG

- OK >> Replace AV control unit.
 NG >> Check harness for open or short between AV control unit and fuse.

RGB Screen is not Shown

EKS006E7

1. CHECK HARNESS

1. Turn ignition switch OFF.
2. Disconnect AV control unit and display connector.
3. Check continuity between AV control unit harness connector M78 terminal 12 (LG), 13 (L/Y) and ground.

Continuity should not exist.

4. Check continuity between AV control unit harness connector M78 terminal 12 (LG) and display harness connector M82 terminal 8 (LG).

Continuity should exist.

5. Check continuity between AV control unit harness connector M78 terminal 13 (L/Y) and display harness connector M82 terminal 5 (L/Y).

Continuity should exist.

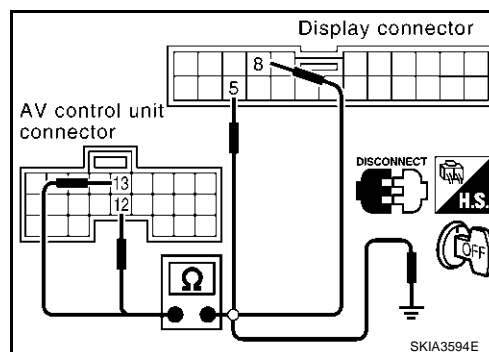

OK or NG

- OK >> GO TO 2.
 NG >> ● Check connector housings for disconnected or loose terminals.
 ● Repair harness or connector.

VEHICLE INFORMATION AND INTEGRATED SWITCH SYSTEM /WITHOUT NAVIGATION SYSTEM

2. CHECK HORIZONTAL SYNCHRONIZATION SIGNAL

1. Connect AV control unit connector and display connector.
2. Turn ignition switch ON.
3. Check voltage between AV control unit harness connector M78 terminals 13 (L/Y) and 10.

13 (L/Y) - 10 : Refer to [DI-101, "Terminals and Reference Value for AV Control Unit"](#) .

OK or NG

- OK >> GO TO 3.
NG >> Replace display.

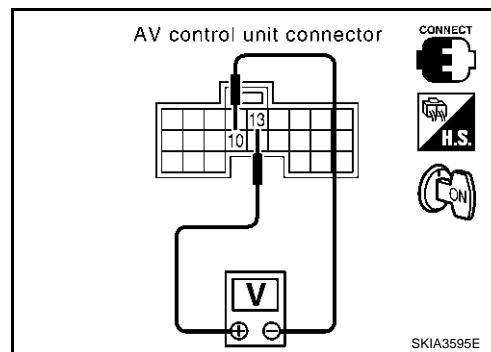

3. CHECK RGB AREA SIGNAL

1. Press "INFO" switch.
2. Check voltage between AV control unit harness connector M78 terminals 12 (LG) and 10.

12 (LG) - 10 : Refer to [DI-101, "Terminals and Reference Value for AV Control Unit"](#) .

OK or NG

- OK >> Replace display.
NG >> Replace AV control unit.

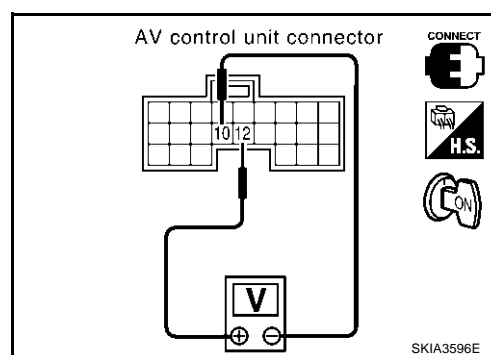

Color of RGB Image is not Proper

1. CHECK COLOR BAR DIAGNOSIS

Check color tone by "SCREEN ADJUSTMENT" of CONFIRMATION/ADJUSTMENT function.

OK or NG

- OK >> Inspection end.
NG >> GO TO 2.

EKS006E8

VEHICLE INFORMATION AND INTEGRATED SWITCH SYSTEM /WITHOUT NAVIGATION SYSTEM

2. CHECK HARNESS

1. Turn ignition switch OFF.
2. Disconnect AV control unit and display connector.
3. Check continuity as follows.

● When the screen looks bluish

Terminals				Continuity
AV control unit		Display		
Connector	Terminal (Wire color)	Connector	Terminal (Wire color)	
M78	18 (L)	M82	1 (L)	Yes
	14	M82	4	Yes

Terminals				Continuity
(+)		(-)		
Connector	Terminal (wire color)			
M78	14, 18 (L)	Ground		No

● When the screen looks reddish

Terminals				Continuity
AV control unit		Display		
Connector	Terminal (Wire color)	Connector	Terminal (Wire color)	
M78	21 (Y)	M82	2 (Y)	Yes
	14	M82	4	Yes

Terminals				Continuity
(+)		(-)		
Connector	Terminal (Wire color)			
M78	14, 21 (Y)	Ground		No

● When the screen looks yellowish

Terminals				Continuity
AV control unit		Display		
Connector	Terminal (Wire color)	Connector	Terminal (Wire color)	
M78	24 (G)	M82	3 (G)	Yes
	14	M82	4	Yes

Terminals				Continuity
(+)		(-)		
Connector	Terminal (Wire color)			
M78	14, 24 (G)	Ground		No

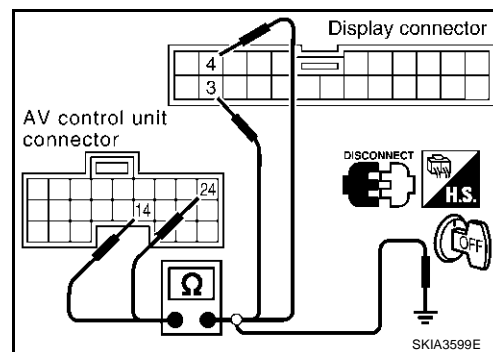
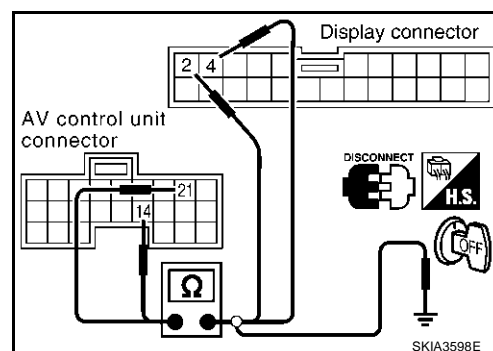
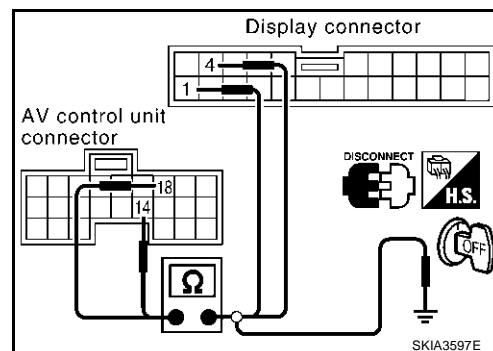

OK or NG

OK >> GO TO 3.

NG >> ● Check connector housings for disconnected or loose terminals.

- Repair harness or connector.

VEHICLE INFORMATION AND INTEGRATED SWITCH SYSTEM /WITHOUT NAVIGATION SYSTEM

3. CHECK RGB SIGNAL

1. Connect AV control unit and display connector.
2. Turn ignition switch ON.
3. Display "Color bar" by "CONFIRMATION/ADJUSTMENT" mode.
4. Check the following with CONSULT-II or oscilloscope.

- **When the screen looks bluish**

Voltage signal between AV control unit harness connector M78 terminal 18 (L) and 14.

18 (L) - 14 : Refer to [DI-101, "Terminals and Reference Value for AV Control Unit"](#) .

- **When the screen looks reddish**

Voltage signal between AV control unit harness connector M78 terminal 21 (Y) and 14.

21 (Y) - 14 : Refer to [DI-101, "Terminals and Reference Value for AV Control Unit"](#) .

- **When the screen looks yellowish**

Voltage signal between AV control unit harness connector M78 terminal 24 (G) and 14.

24 (G) - 14 : Refer to [DI-101, "Terminals and Reference Value for AV Control Unit"](#) .

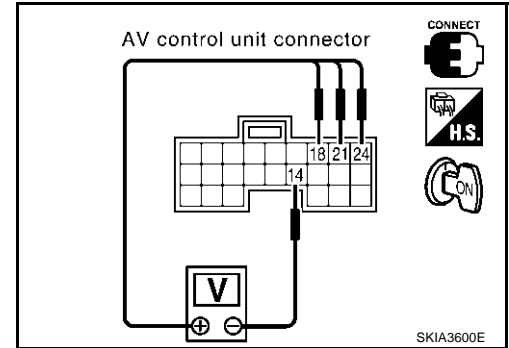

OK or NG

- OK >> Replace display.
- NG >> Replace AV control unit.

RGB Screen Is Rolling

1. CHECK HARNESS

1. Turn ignition switch OFF.
2. Disconnect AV control unit and display connector.
3. Check continuity between AV control unit and ground.

Terminals		Continuity
(+)	(-)	
Connector	Terminal (Wire color)	Ground
M78	15 (L/R) 10	
		No

4. Check continuity between AV control unit and display.

Terminals				Continuity
AV control unit		Display		
Connector	Terminal (Wire color)	Connector	Terminal (Wire color)	
M78	15 (L/R)	M82	7 (L/R)	Yes
	10		4	

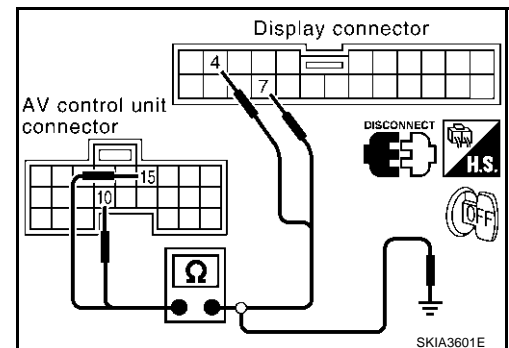

OK or NG

- OK >> GO TO 2.
- NG >> ● Check connector housings for disconnected or loose terminals.
 - Repair harness or connector.

2. CHECK RGB SYNCHRONIZING SIGNAL

1. Connect AV control unit and display connector.
2. Turn ignition switch ON.
3. Check voltage between AV control unit harness connector M78 terminal 15 (L/R) and 10.

15 (L/R) - 10 : Refer to [DI-101, "Terminals and Reference Value for AV Control Unit"](#) .

OK or NG

- OK >> Replace display.
- NG >> Replace AV control unit.

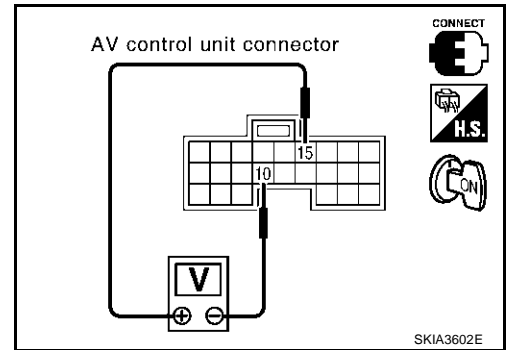

EKS006RM

No A/C Display is Shown

Refer to [ATC-105, "No A/C Display is Shown"](#) in ATC section.

A/C Operation Is Not Possible

Refer to [ATC-106, "A/C Operation is not Possible."](#) in ATC section.

EKS006RN

No Fuel Information Is Displayed/No Warning Message Is Displayed

EKS006EA

1. CHECK HARNESS

1. Disconnect AV control unit and combination meter, BCM connector.
2. Check continuity between AV control unit harness connector M77 terminal 34 (LG), 35 (PU) and ground.

Continuity should not exist.

3. Check continuity between AV control unit harness connector M77 terminal 34 (LG) and combination meter harness connector M41 terminal 7 (LG).

Continuity should exist.

4. Check continuity between AV control unit harness connector M77 terminal 35 (PU) and combination meter harness connector M41 terminal 6 (PU).

Continuity should exist.

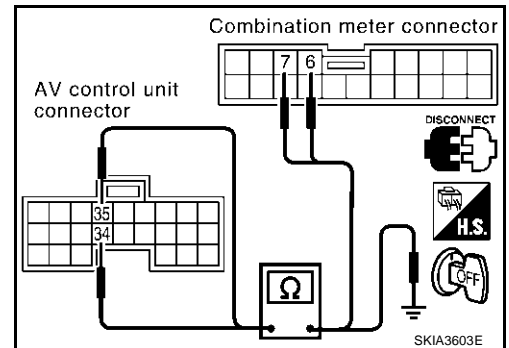

OK or NG

- OK >> GO TO 2.
- NG >> ● Check connector housings for disconnected or loose terminals.
 - Repair harness or connector.

2. CHECK COMMUNICATION SIGNAL (AV-ME)

1. Connect combination meter, BCM and AV control unit connector.
2. Turn the ignition switch ON.
3. Check voltage signal between AV control unit harness connector M77 terminal 34 (LG) and ground with CONSULT-II or oscilloscope.

34 (LG) - Ground : Refer to [DI-101, "Terminals and Reference Value for AV Control Unit"](#) .

OK or NG

- OK >> GO TO 3.
- NG >> Replace AV control unit.

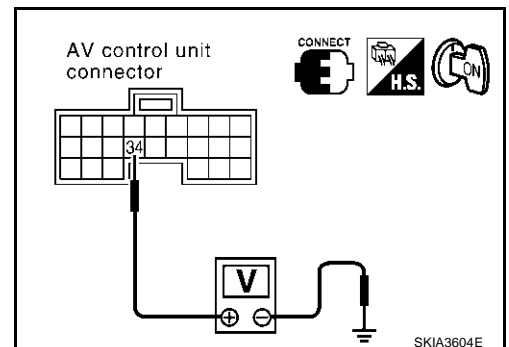

VEHICLE INFORMATION AND INTEGRATED SWITCH SYSTEM /WITHOUT NAVIGATION SYSTEM

3. CHECK COMMUNICATION SIGNAL (ME-AV)

1. Turn ignition switch to ON and display "VEHICLE ELECTRONIC SYSTEMS" screen.
2. Check voltage signal between AV control unit harness connector M77 terminal 35 (PU) and ground with CONSULT-II or oscilloscope.

35 (PU) - Ground : Refer to [DI-101, "Terminals and Reference Value for AV Control Unit"](#) .

OK or NG

- OK >> Replace AV control unit.
NG >> Replace combination meter.

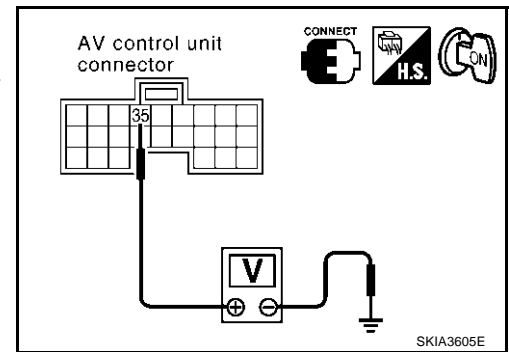

Vehicle Condition Setting Is Not Possible

EKS006EB

1. CHECK HARNESS

1. Disconnect AV control unit, combination meter and BCM connector.
2. Check continuity between AV control unit harness connector M77 terminal 34 (LG), 35 (PU) and ground.

Continuity should not exist.

3. Check continuity AV control unit harness connector M77 terminal 34 (LG) and BCM harness connector M4 terminal 31 (LG).

Continuity should exist.

4. Check continuity AV control unit harness connector M77 terminal 35 (PU) and BCM harness connector M4 terminal 30 (PU).

Continuity should exist.

OK or NG

- OK >> GO TO 2.
NG >> ● Check connector housings for disconnected or loose terminals.
● Repair harness or connector.

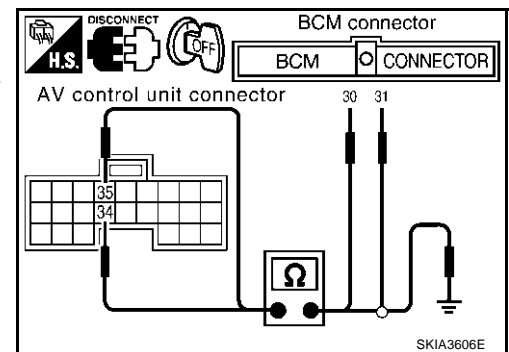

2. CHECK COMMUNICATION SIGNAL (AV-ME)

1. Connect AV control unit, combination meter and BCM connector.
2. Turn ignition switch ON.
3. Check voltage signal between AV control unit harness connector M77 terminal 34 (LG) and ground with CONSULT-II or oscilloscope.

34 (LG) - Ground : Refer to [DI-101, "Terminals and Reference Value for AV Control Unit"](#) .

OK or NG

- OK >> GO TO 3.
NG >> Replace AV control unit.

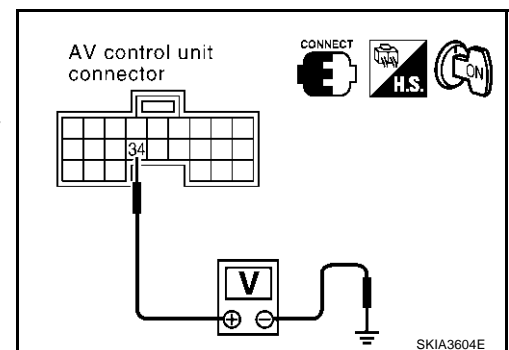

3. CHECK COMMUNICATION SIGNAL (ME-AV)

1. Turn ignition switch to ON and display "VEHICLE ELECTRONIC SYSTEMS" screen.
2. Check voltage signal between AV control unit harness connector M77 terminal 35 (PU) and ground with CONSULT-II or oscilloscope.

35 (PU) - Ground : Refer to [DI-101, "Terminals and Reference Value for AV Control Unit"](#) .

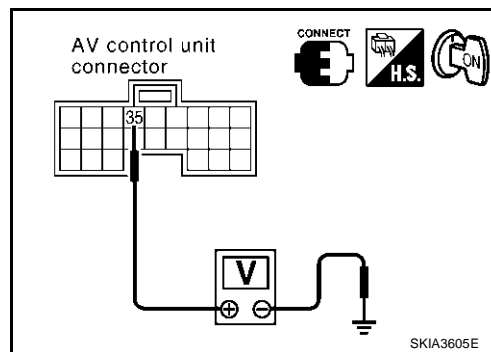

OK or NG

- OK >> Replace AV control unit.
- NG >> Replace BCM.

Multifunction Switch Does Not Operate

EKS006TW

Inspection procedure

1. MULTIFUNCTION SWITCH SELF-DIAGNOSIS

Perform multifunction switch self-diagnosis. Refer to [DI-118, "Multifunction Switch Self-Diagnosis Function"](#) .

Is self-diagnosis result OK?

- OK >> GO TO 2.
- NG >> Replace multifunction switch.

2. CHECK POWER AND GROUND CIRCUIT

Check power and ground circuit. Refer to [DI-121, "Inspection of Multifunction Switch for Power Supply and Ground Circuit"](#) .

OK or NG

- OK >> GO TO 3
- NG >> Repair or replace harness.

3. COMMUNICATION CIRCUIT SELF-DIAGNOSIS

Perform the self-diagnosis mode in the self-diagnosis function (If the self-diagnosis cannot be activated with the multifunction switch, check with CONSULT-II). Refer to [DI-109, "Self-Diagnosis Mode"](#) .

Is self-diagnosis result OK?

- OK >> Replace display
- NG >> With the self-diagnosis results, check the malfunction part.

Multifunction Switch Indicator Does Not illuminate

EKS006TX

1. MULTIFUNCTION SWITCH SELF-DIAGNOSIS

Perform the multifunction switch self-diagnosis. Refer to [DI-118, "Multifunction Switch Self-Diagnosis Function"](#) .

Is the self-diagnosis result OK?

- OK >> Replace switch of the malfunctioning indicator
- NG >> Replace multifunction switch.

VEHICLE INFORMATION AND INTEGRATED SWITCH SYSTEM /WITHOUT NAVIGATION SYSTEM

Removal and Installation of Display

EKS006TO

REMOVAL

1. Remove the cluster lid C. Refer to [IP-10, "INSTRUMENT PANEL ASSEMBLY"](#)
2. Remove the screws (4), and remove the display.

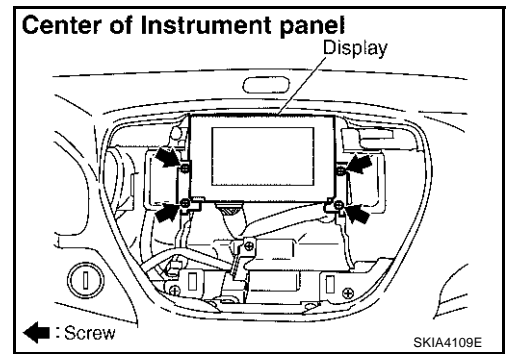

INSTALLATION

Install in the reverse order of removal.

Disassembly and Assembly for Multifunction Switch

EKS006TP

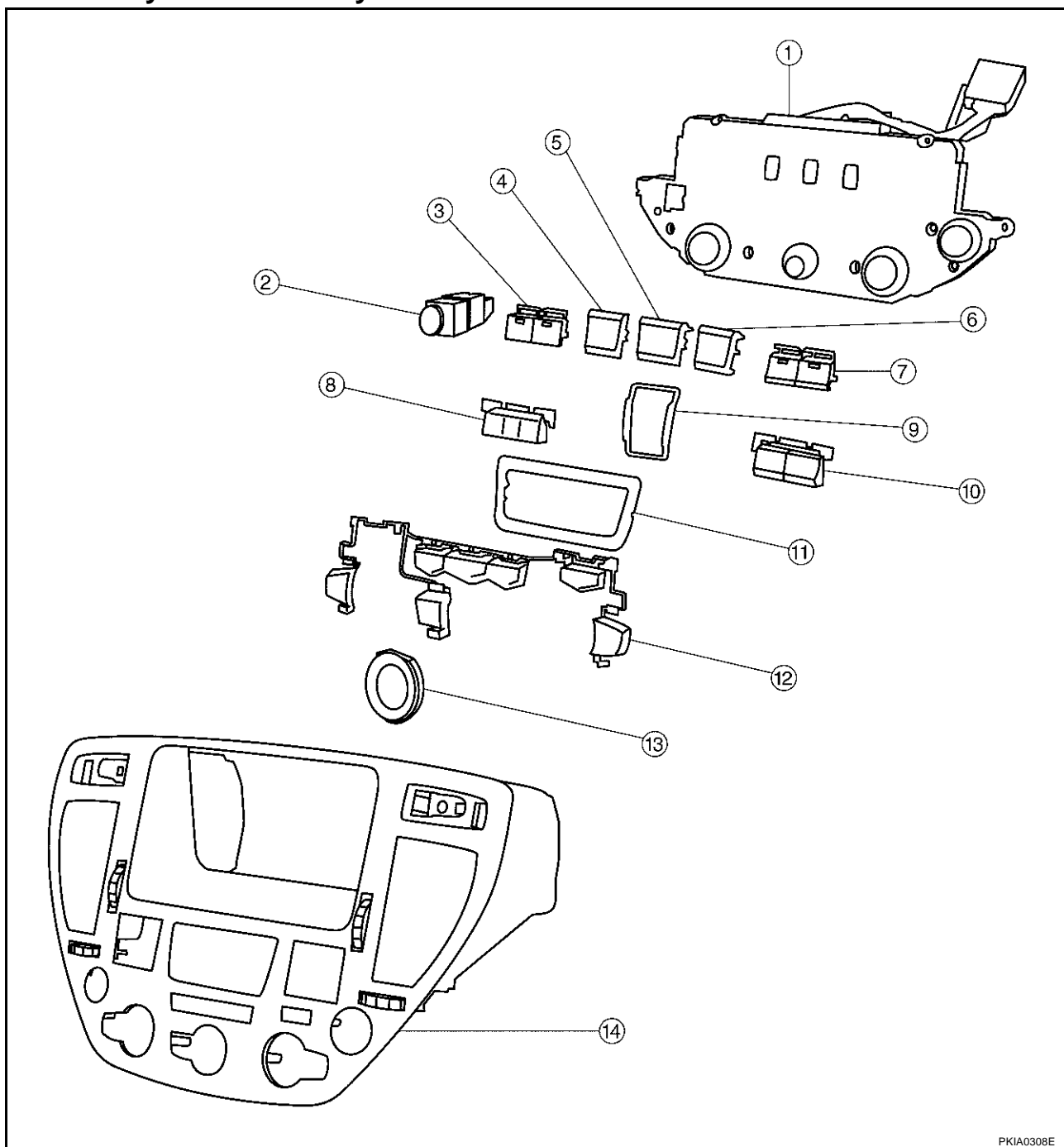

A
B
C
D
E
F
G
H
I
J
DI
L
M

PKIA0308E

- | | | |
|------------------------|-------------------|-----------------------------------|
| 1 Multifunction switch | 2 Hazard switch | 3 Defroster, rear defogger switch |
| 4 Function switch | 5 Function switch | 6 Function switch |
| 7 TAPE and DISC switch | 8 A/C switch | 9 Escutcheon |
| 10 AM and FM switch | 11 Escutcheon | 12 Switch assembly |
| 13 Escutcheon | 14 Cluster lid C | |

1. Remove the screw (7)
2. Remove the switches.

VEHICLE INFORMATION AND INTEGRATED SWITCH SYSTEM /WITHOUT NAVIGATION SYSTEM

Removal and Installation of AV Control Unit

EKS006EC

REMOVAL

1. Remove cluster lid C. Refer to [IP-10, "INSTRUMENT PANEL ASSEMBLY"](#) .
2. Remove warning chime. Refer to [DI-75, "Removal and Installation of Warning Chime"](#) .
3. Remove tire pressure warning control unit. Refer to [WT-8, "TIRE PRESSURE WARNING CONTROL UNIT"](#) .
4. Remove the screws (2), and remove AV control unit.

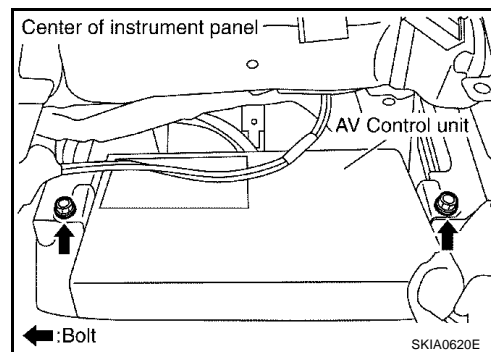

INSTALLATION

Install in the reverse order of removal.

VEHICLE INFORMATION AND INTEGRATED SWITCH SYSTEM /WITH NAVIGATION SYSTEM

PPF:28395

A

System Description INTEGRATED SWITCH SYSTEM

EKS006EE

B

Using the multifunction switch at the center of the instrument panel, the controls of the following systems are centralized:

- Auto A/C system
- Vehicle information system
- Audio system
- Navigation system
- Hazard switch

C

D

The multifunction switch can operate and check the vehicle condition and each setting (vehicle electrical system).

E

PRECAUTION OF LCD MONITOR

- When passenger compartment temperature is low, the LCD monitor sometimes dims because of the brightness of the back light (small fluorescent light) integrated into the LCD monitor decrease. In this case, the refreshing rate of the picture also becomes low because of the low response of the LCD monitor. When passenger compartment becomes warm, however, the LCD recovers the normal display.
- Sometimes, black or bright dots peculiar to LCD monitor can be seen on the display.
- Back light sometimes flickers or darkens according to the total consumption hours and the number of ON and OFF switching. In this case, the back light should be replaced. (LCD monitor assembly)

F

G

H

POWER SUPPLY AND GROUND

Power is Supplied at All Times

- through 15 A fuse [No. 52, located in fuse, fusible link and relay box (J/B)]
- to AV and NAVI control unit terminals 2 and 3, and
- to display terminals 21 and 23.

I

J

When Ignition Switch is in ACC or ON Position, Power is Supplied

- through 10 A fuse [No.21, located in fuse block (J/B) No. 1]
- to AV and NAVI control unit terminal 6, and
- to display terminal 19, and
- to multifunction switch terminal 1.

DI

When Ignition Switch is in ON or START Position, Power is Supplied

- through 10 A fuse [No. 1, located in fuse block (J/B) No. 1]
- to AV and NAVI control unit terminal 26.

L

Ground is Supplied

- to AV and NAVI control unit terminal 1 and 4
- through body grounds B17 and B57, and
- to multifunction switch terminal 2 and
- to display terminals 22 and 24
- through body grounds M24 and M114.

M

AV COMMUNICATION LINE

AV and NAVI control unit is connected to the following units by AV communication line. Each unit transmits/receives data with AV communication line.

- Display
- Multifunction switch
- Audio unit
- Bose speaker amp.
- Rear view camera control unit

VEHICLE INFORMATION AND INTEGRATED SWITCH SYSTEM /WITH NAVIGATION SYSTEM

- Low tire pressure warning control unit
- Voice activated control module

VEHICLE INFORMATION SYSTEM

- AV and NAVI control unit is received vehicle information system of signals from combination meter.
 - AV and NAVI control unit is communicating with BCM and combination meter.
1. Press “INFO” switch to display vehicle information display.

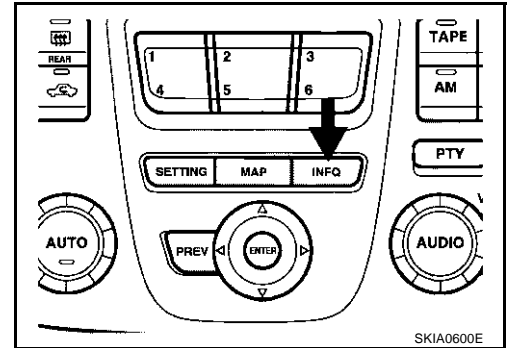

2. Select “Trip Computer”, “Fuel Economy”, “Maintenance” or “Tire pressure”.

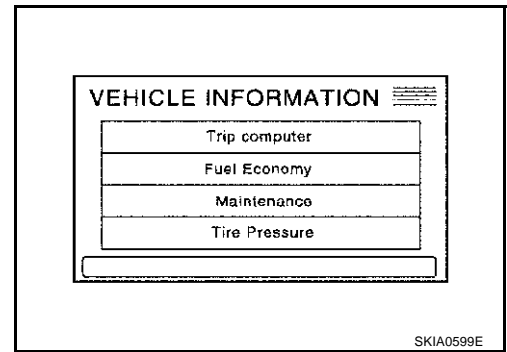

Display items	Display/Setting contents
Trip Computer	Elapsed Time
	Driving Distance
	Average speed
Fuel Economy	Average Fuel Economy (MPG)
	Distance to Empty (Miles)
	Fuel Economy (MPG)
	Fuel Economy Record
Maintenance (with Maintenance information*)	Maintenance intervals of engine oil and setting of oil change cycle
	Maintenance intervals of oil filter and setting of filter replacement cycle
	Maintenance intervals of tire and setting of tire replacement cycle
Tire Pressure	Tire pressure information.

*:Maintenance information displays the change cycle of engine oil, oil filter and tire on LCD monitor depending on the driving distance specified by a driver or a technician.

VEHICLE INFORMATION AND INTEGRATED SWITCH SYSTEM /WITH NAVIGATION SYSTEM

Trip Computer Information

1. Select "Trip Computer"
2. Elapsed time, Driving distance and Average speed are displayed as Trip Computer information.

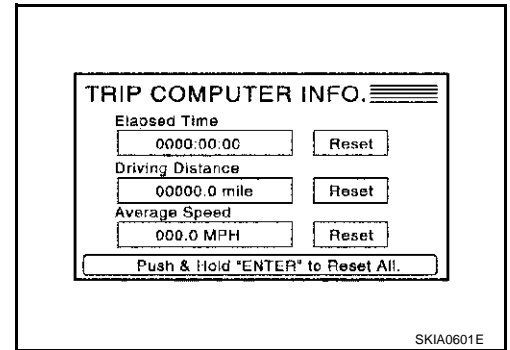

A
B
C
D

Fuel Economy Information

1. Select "Fuel Economy"
2. Average Fuel Economy, Distance to Empty, Fuel Economy are displayed as Fuel Economy information.

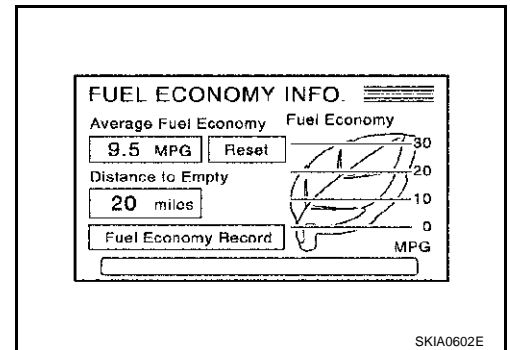

E
F
G
H

3. Select "Fuel Economy Record". The average fuel consumption history will be displayed in graph along with the average for the previous Reset – to – Reset period.

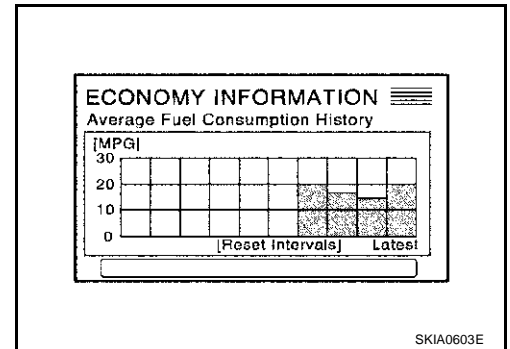

I
J
DI

Maintenance Information

1. Select "Maintenance"
2. Engine Oil, Oil Filter and Tire Rotation are displayed as Maintenance information.

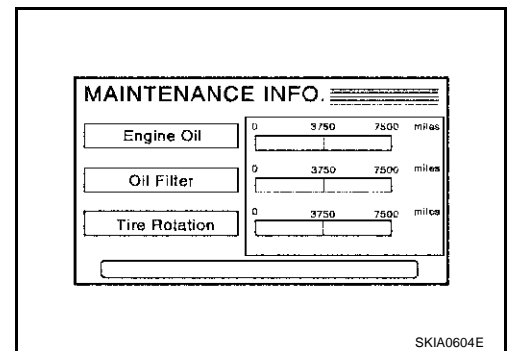

L
M

VEHICLE INFORMATION AND INTEGRATED SWITCH SYSTEM /WITH NAVIGATION SYSTEM

Tire Pressure Information

1. Select "Tire Pressure"
2. Tire pressure displayed as Tire pressure information

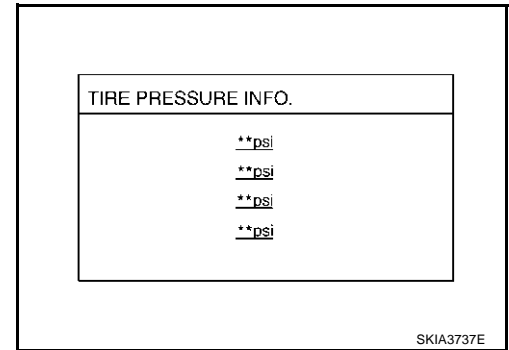

NOTE:

- When air pressure becomes 180 kPa (1.8 kg/cm² , 26 psi) or less, "LOW PRESSURE" warning is indicated.
- When air pressure becomes 70 kPa (0.7 kg/cm² , 10 psi) or less, "FLAT TIRE" warning is indicated.
- When pressure is not detected or tire pressure system has malfunction "*** psi" is indicated.
- Indication with yellow frame for the malfunctioning tire.

SETTING OF VEHICLE STATUS

- Setting of electric status can be changed by multifunction switch. The signal is sent to BCM through AV and NAVI control unit to change vehicle electric system setting.
 - AV and NAVI control unit is communicating with BCM and combination meter.
1. Press "SETTING" switch to display vehicle information display.

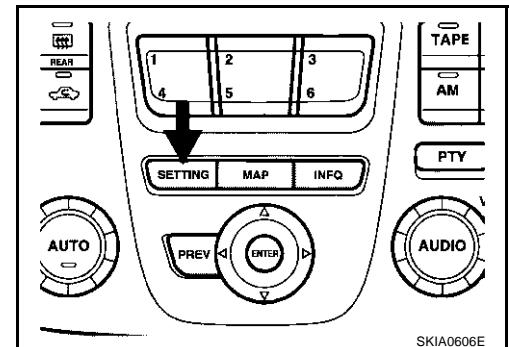

2. Select "Vehicle Electronic System".

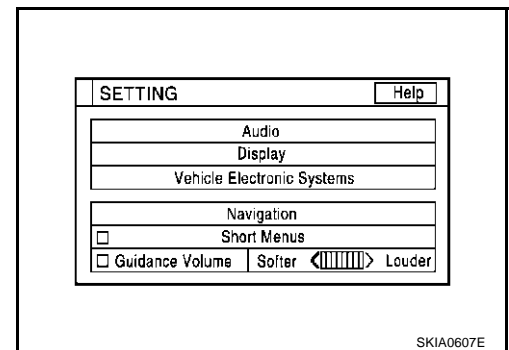

3. Select a vehicle status shown on the display.

VEHICLE INFORMATION AND INTEGRATED SWITCH SYSTEM /WITH NAVIGATION SYSTEM

Adjustable vehicle status

- Lift Steering Column When Exiting Vehicle.
- Adjust Driver Seat When Exiting Vehicle
- Illuminate Interior When Unlocking Vehicle
- Interior Lights Off Delay

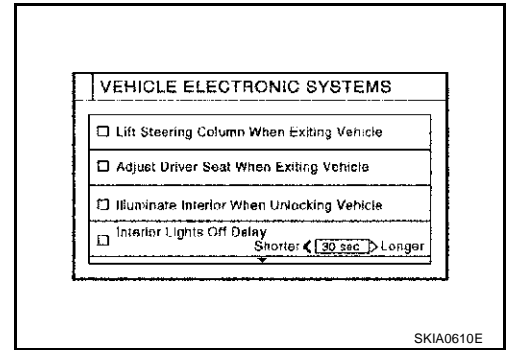

- Sensitivity of Automatic Headlights
- Automatic Headlights Off Delay
- Key Remote Response-Horn/Lights
- Remote Custom Settings

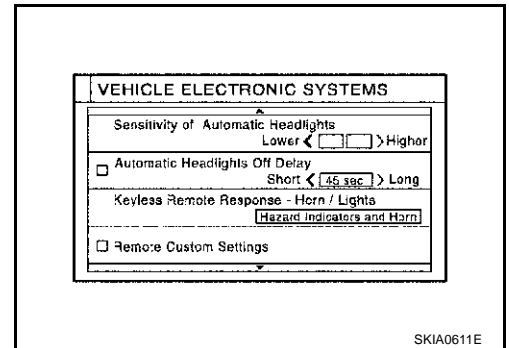

- Return All Setting to Default

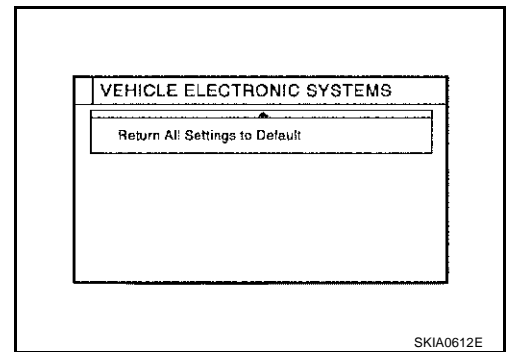

A
B
C
D
E
F
G
H
I
J
DI
L
M

VEHICLE INFORMATION AND INTEGRATED SWITCH SYSTEM /WITH NAVIGATION SYSTEM

Adjustable Vehicle Status

Setting items	Setting variations	Initial setting	Operation
Lift Steering Column When Exiting Vehicle	ON/OFF	ON	<p>The steering column automatically tilts up when the driver gets out, and returns to the original position when the driver gets on.</p> <ul style="list-style-type: none"> When driver door is closed and key removed from ignition key cylinder, the steering column tilts up. When driver door is open and key is turned to OFF, the steering column tilts up.
Adjust Driver Seat When Exiting Vehicle	ON/OFF	ON	<p>The driver's seat automatically slides backward when the driver gets out, and returns to the original position when the driver gets on.</p>
Illuminate Interior When Unlocking Vehicle	ON/OFF	ON	<p>The interior room lamps are illuminate automatically when the door unlocked with key or key fob.</p>
Interior Lights Off Delay	OFF/15/30/45 sec.	30 sec.	<p>Interior room lamp timer period can be changed in this mode. Selects interior room lamp timer.</p>
Sensitivity of Automatic Headlights	1/2/3/4	3	<p>Sensitivity of auto light sensor can be adjusted.</p>
Automatic Headlights Off Delay	OFF/20/45/90/120/150/180 sec.	45 sec.	<p>Auto light delay off timer period can be changed in this mode. Selects auto light delay off timer.</p>
Key Remote Response - Horn/Lights	Hazard indicators only /Hazard indicators and horn	Hazard indicators only	<p>Hazard indicators Only:</p> <ul style="list-style-type: none"> Lock operation: The hazard warning lamp flash twice when lock the doors with key fob. Unlock operation: No response. <p>Hazard indicators and horn:</p> <ul style="list-style-type: none"> Lock operation: The hazard warning lamp flash twice and horn sounds once when lock the doors with key fob. Unlock operation; The hazard warning lamp flash once when unlock the doors with key fob.
Remote Custom Settings	ON/OFF	ON	<p>The driving position -seat and steering column- and the audio setting -current source and radio station presets- are set to the same condition you made last time by identifying the key fob ID.</p> <p>This function operates when unlock the doors by using the key fob.</p> <p>NOTE: It is necessary to memorize the driving position before using this function.</p>
Return All Settings to Default	None	None	<p>If this key is selected, all vehicle electronic systems setting are return to default.</p>

VEHICLE INFORMATION AND INTEGRATED SWITCH SYSTEM /WITH NAVIGATION SYSTEM

WARNING INDICATIONS

When combination meter receives warning signal from some control units or sensors, then combination meter warning lamp is illuminated.
Then combination meter sends warning signal to AV and NAVI control unit to display warning indications on the screen.

Warning indicators	Warning lamps in instrument panel	Warning detection and cancel conditions		Cases of malfunction
MALFUNCTION	SERVICE ENGINE SOON	Detection condition	Warning lamp ON signal is detected while engine is running.	ECM malfunction
		Cancel condition	Warning lamp OFF signal is detected.	
ENGINE OIL PRESSURE	Engine oil pressure	Detection condition	Warning lamp ON signal is detected for at least approx. 5 seconds while engine is running. [Engine oil pressure: MAX. approx. 29kPa (0.3 kg/cm ² , 4psi)]	Engine oil pressure decreases
		Cancel condition	Warning lamp OFF signal is detected. [Engine oil pressure: MIN. approx. 29kPa (0.3kg/cm ² , 4psi)]	
SUPPLEMENTAL AIR BAG	Air bag	Detection condition	Warning lamp ON signal is detected for at least approx. 10 seconds after ignition switch is turned ON.	SRS air bag system malfunction
		Cancel condition	Warning lamp OFF signal is detected.	
LOW BRAKE FLUID	Brake	Detection condition	Warning lamp ON signal (fluid level) is detected.	Low brake fluid level
		Cancel condition	Warning lamp OFF signal is detected.	
OVERHEATING	-	Detection condition	Engine coolant temperature as being approx. 119°C (246°F) min.	Engine cooling system malfunction
		Cancel condition	Engine coolant temperature as being approx. 105°C (221°F) max.	
CHARGE	Charge	Detection condition	Warning lamp ON signal is detected while engine is running. Charging system malfunction	Charging system malfunction
		Cancel condition	Warning lamp OFF signal is detected.	
LOW WASHER FLUID	-	Detection condition	Washer liquid level falls below approx. 0.4 ℓ (7/8USqt, 3/4 Imp pt)	Low washer liquid level
		Cancel condition	Except above condition.	
LOW FUEL	Fuel level	Detection condition	After warning lamp ON signal is detected, vehicle is driven for over specified distance. (Fuel level: Approx. 14.0 ℓ (14-3/4 USqt, 12-3/8 Imp pt)	Low fuel level
		Cancel condition	Warning lamp OFF signal is detected.	
PARKING BRAKE	Brake	Detection condition	Parking brake ON signal is detected while vehicle is running [approx. 5 km/h (3MPH) or faster].	Parking brake remains engaged.
		Cancel condition	Vehicle is stopped, or parking brake OFF signal is detected.	

VEHICLE INFORMATION AND INTEGRATED SWITCH SYSTEM /WITH NAVIGATION SYSTEM

Warning indicators	Warning lamps in instrument panel	Warning detection and cancel conditions		Cases of malfunction
DOOR OPEN	Door	Detection condition	Vehicle is running [approx. 5 km/h (3 MPH) or faster] and door ajar of any of the doors is detected.	Door is open
		Cancel condition	Vehicle is stopped and all the doors lock.	
ANTI-LOCK BRAKE	ABS	Detection condition	Warning lamp ON signal is detected when engine is running.	ABS control system malfunction
		Cancel condition	Warning lamp OFF signal is detected.	
VEHICLE DYNAMIC CONTROL	VDC	Detection condition	Warning lamp ON signal is detected when engine is running.	VDC system malfunction
		Cancel condition	Warning lamp OFF signal is detected.	
TRACTION CONTROL SYSTEM	TCS	Detection condition	Warning lamp ON signal is detected when engine is running.	TCS system malfunction
		Cancel condition	Warning lamp OFF signal is detected.	
AUTOMATIC TRANSMISSION OIL TEMPERATURE	AT CHECK	Detection condition	Warning lamp ON signal is detected after ignition switch is turned ON.	TCM system malfunction
		Cancel condition	Warning lamp OFF signal is detected.	
TIRE PRESSURE		Detection condition	Warning lamp ON signal is detected after ignition switch is turned ON.	Low tire pressure warning control unit system malfunction
		Cancel condition	Warning lamp OFF signal is detected.	
LOW TIRE PRESSURE (TIRE PRESSURE INFO.)	Tire Pressure	Detection condition	Tire pressure 180 kPa (1.8 kg/cm ² , 26 psi) is detected while vehicle is running.	Tire air pressure is low
		Cancel condition	Except above condition.	
FLAT TIRE (TIRE PURSUER INFO.)		Detection condition	Tire pressure 70 kPa (0.7 kg/cm ² , 10 psi) is detected while vehicle is running.	Flat tire
		Cancel condition	Except above condition.	
CRUISE CONTROL	SET	Detection condition	Warning lamp ON signal is detected after ignition switch is turned ON.	ASC system malfunction
		Cancel condition	Warning lamp OFF signal is detected.	

VEHICLE INFORMATION AND INTEGRATED SWITCH SYSTEM /WITH NAVIGATION SYSTEM

Precautions for AV and NAVI Control Unit Replacement

EKS006EF

- When replacing the AV and NAVI control unit, eject the map DVD-ROM before disconnecting the battery.
- The AV and NAVI control unit has the following information stored in its memory. Record the memory contents before replacing the control unit, and input them in the new unit as necessary.

- | | |
|---|---|
| <p><FM-AM></p> <p><CD></p> <p><Sound quality></p> <p><Image quality></p> <p><Navigation mode></p> | <ul style="list-style-type: none"> • Preset frequency • Area for indicating station, selection of overlapped stations • Program status • Volume balance memory set values • Equalizer memory set values • Brightness of light when ON/OFF • Dimming switching • Display color switching • Latest status (MAP screen/BIRD VIEW™, reduced scale, rotation angle of map screen, route guide ON/OFF, track ON/OFF, etc.) • Current position • Destination, passing point 1 - 5 • Registered places, their names, etc. |
|---|---|

NOTE:

Only removing the battery does not erase the memory.

Component Parts and Harness Connector Location

EKS006EG

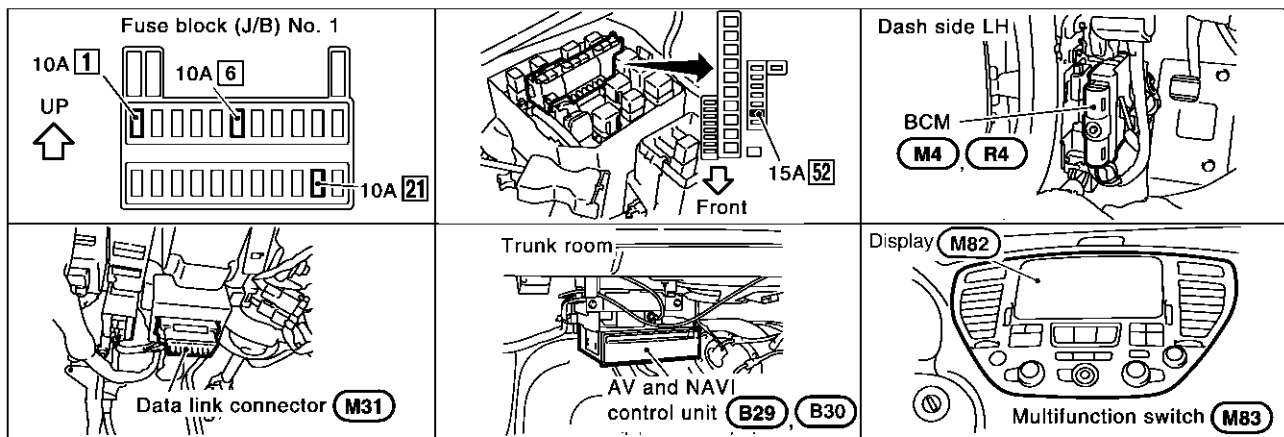

SKIA4044E

VEHICLE INFORMATION AND INTEGRATED SWITCH SYSTEM /WITH NAVIGATION SYSTEM

Schematic

EKS006EH

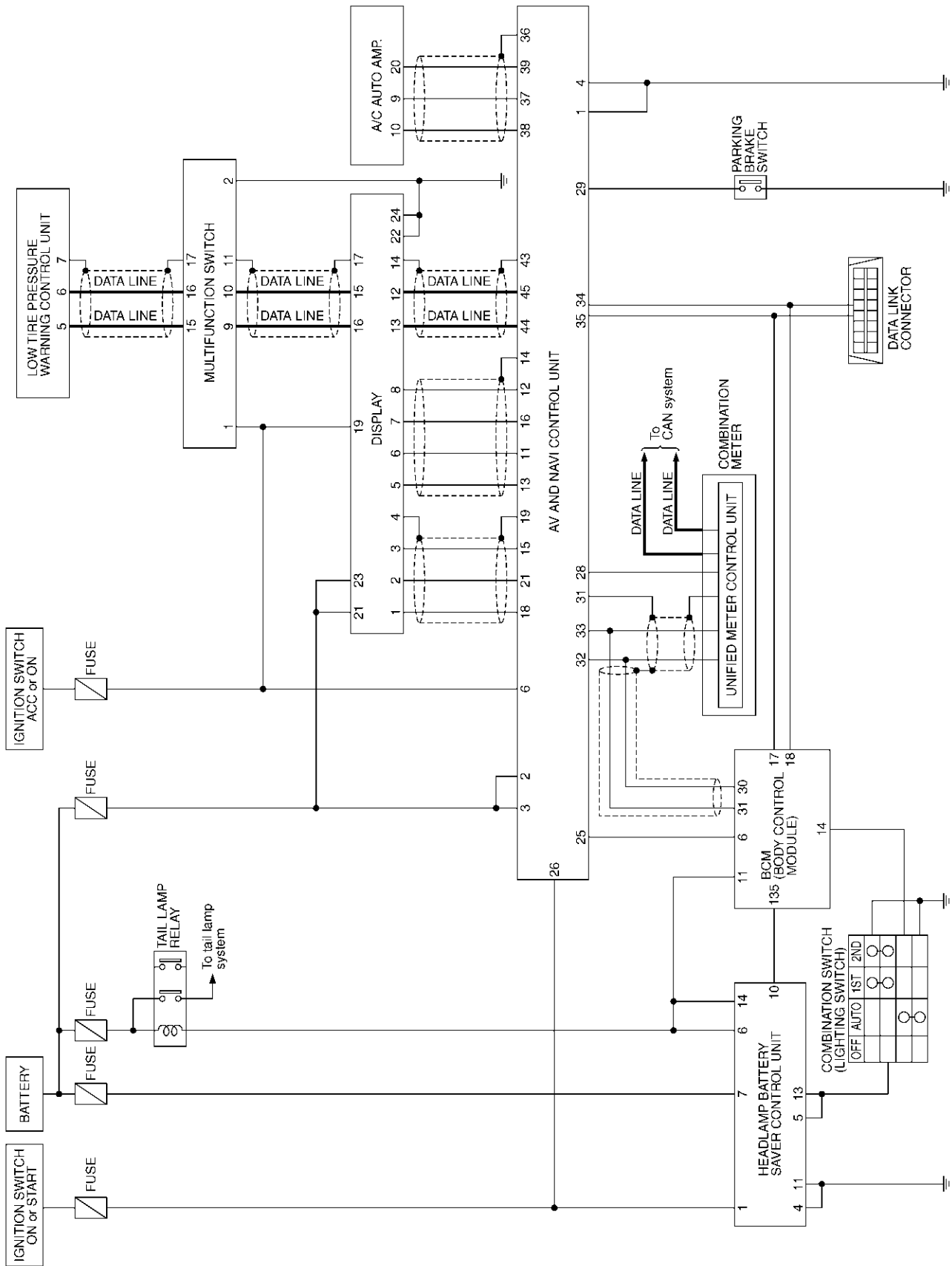

TKWM0729E

VEHICLE INFORMATION AND INTEGRATED SWITCH SYSTEM /WITH NAVIGATION SYSTEM

Wiring Diagram — INF/D —

EKS006E1

DI-INF/D-09

A
B
C
D
E
F
G
H
I
J
DI
L
M

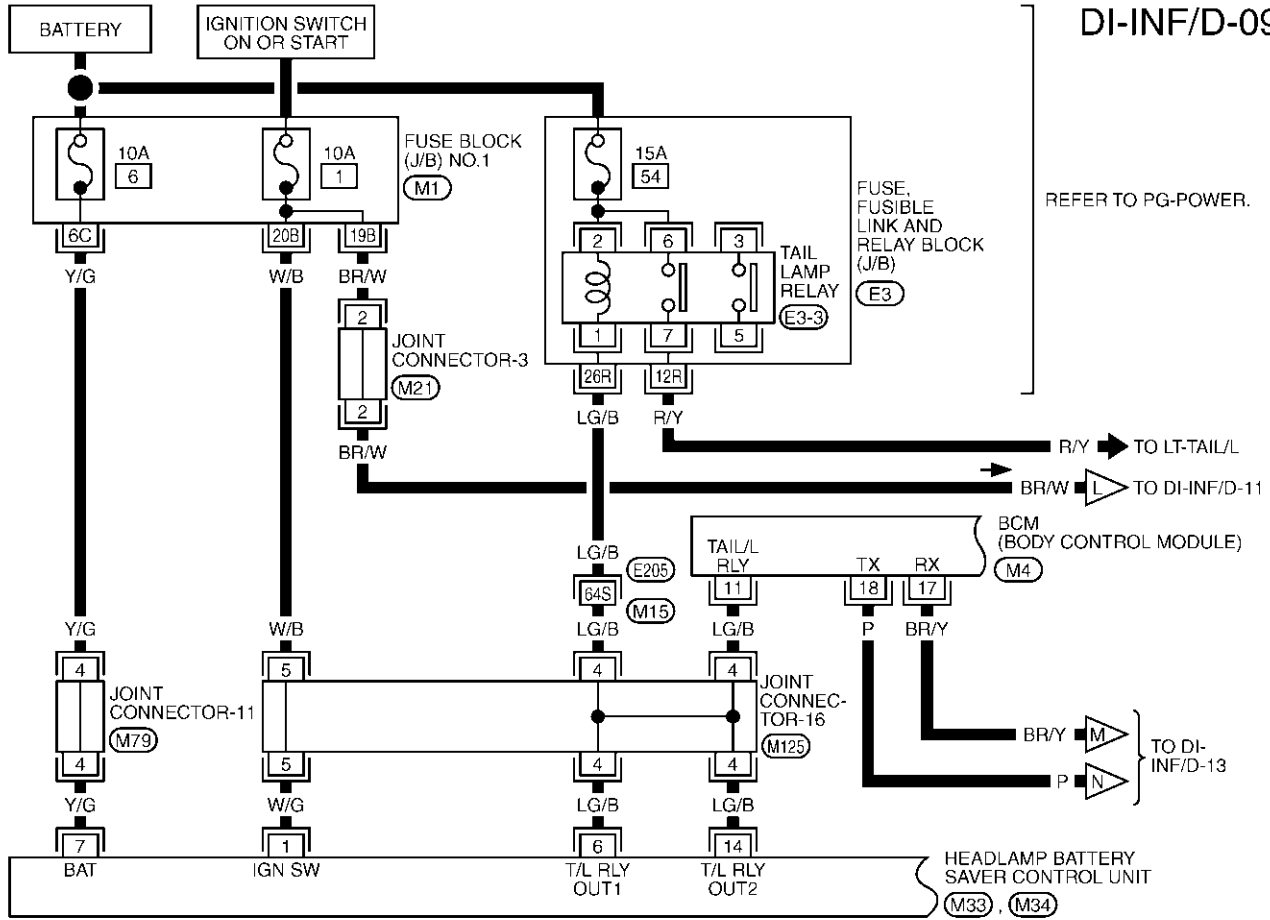

REFER TO PG-POWER.

REFER TO THE FOLLOWING.

- (E205) -SUPER MULTIPLE JUNCTION (SMJ)
- (M1) -FUSE BLOCK-JUNCTION BOX (J/B) NO.1
- (E3) -FUSE,FUSIBLE LINK AND RELAY BLOCK (J/B)
- (M4) -ELECTRICAL UNITS

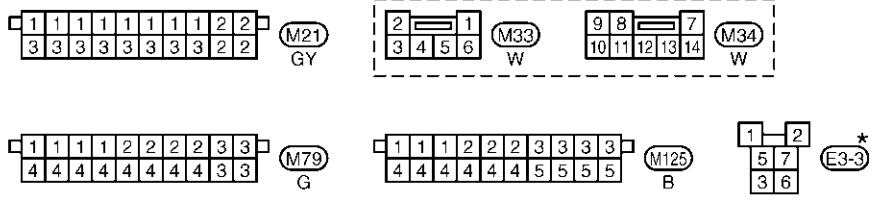

*: THIS CONNECTOR IS NOT SHOWN IN "HARNESS LAYOUT", PG SECTION.

TKWM0730E

VEHICLE INFORMATION AND INTEGRATED SWITCH SYSTEM /WITH NAVIGATION SYSTEM

DI-INF/D-10

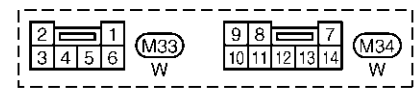
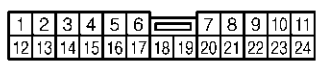
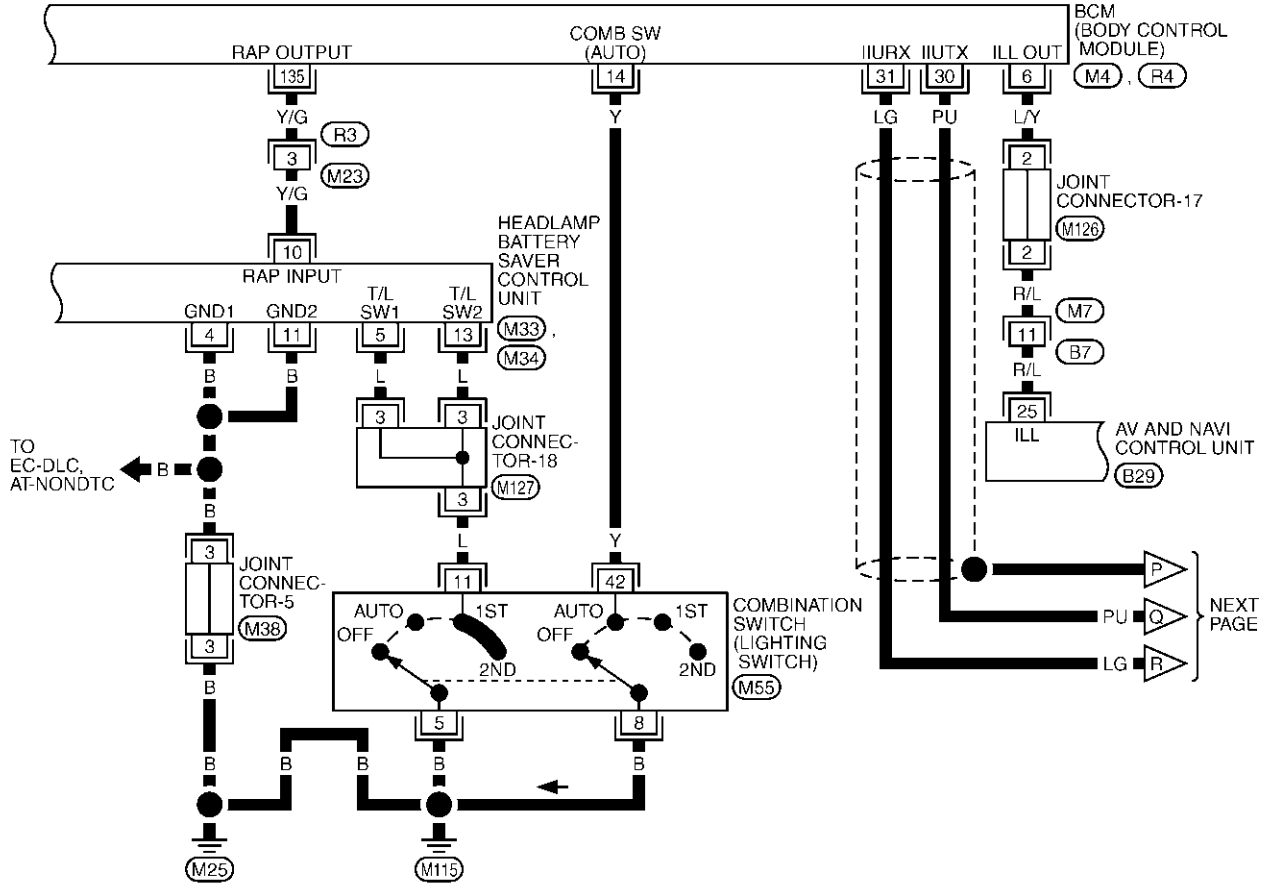

REFER TO THE FOLLOWING.
(M4), (R4) -ELECTRICAL UNITS

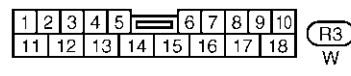
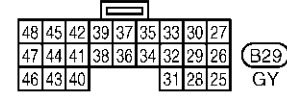
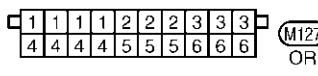
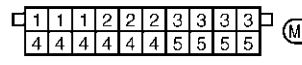
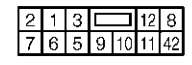
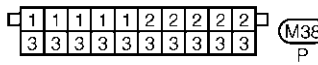

TKWM0731E

VEHICLE INFORMATION AND INTEGRATED SWITCH SYSTEM /WITH NAVIGATION SYSTEM

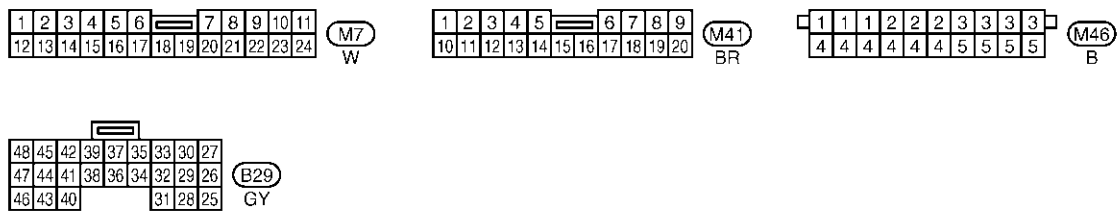
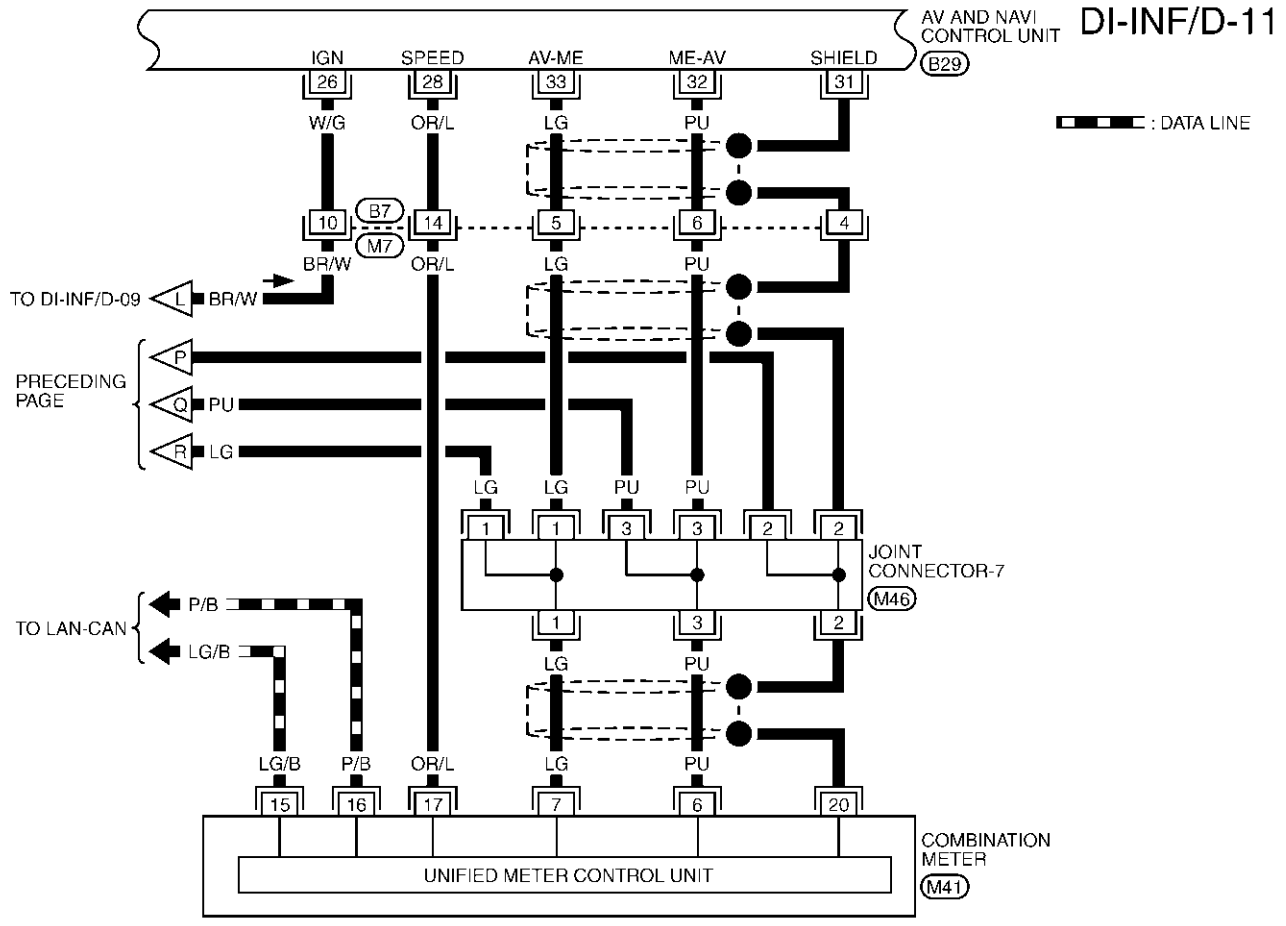

A
B
C
D
E
F
G
H
I
J
DI
L
M

TKWM0732E

VEHICLE INFORMATION AND INTEGRATED SWITCH SYSTEM /WITH NAVIGATION SYSTEM

DI-INF/D-12

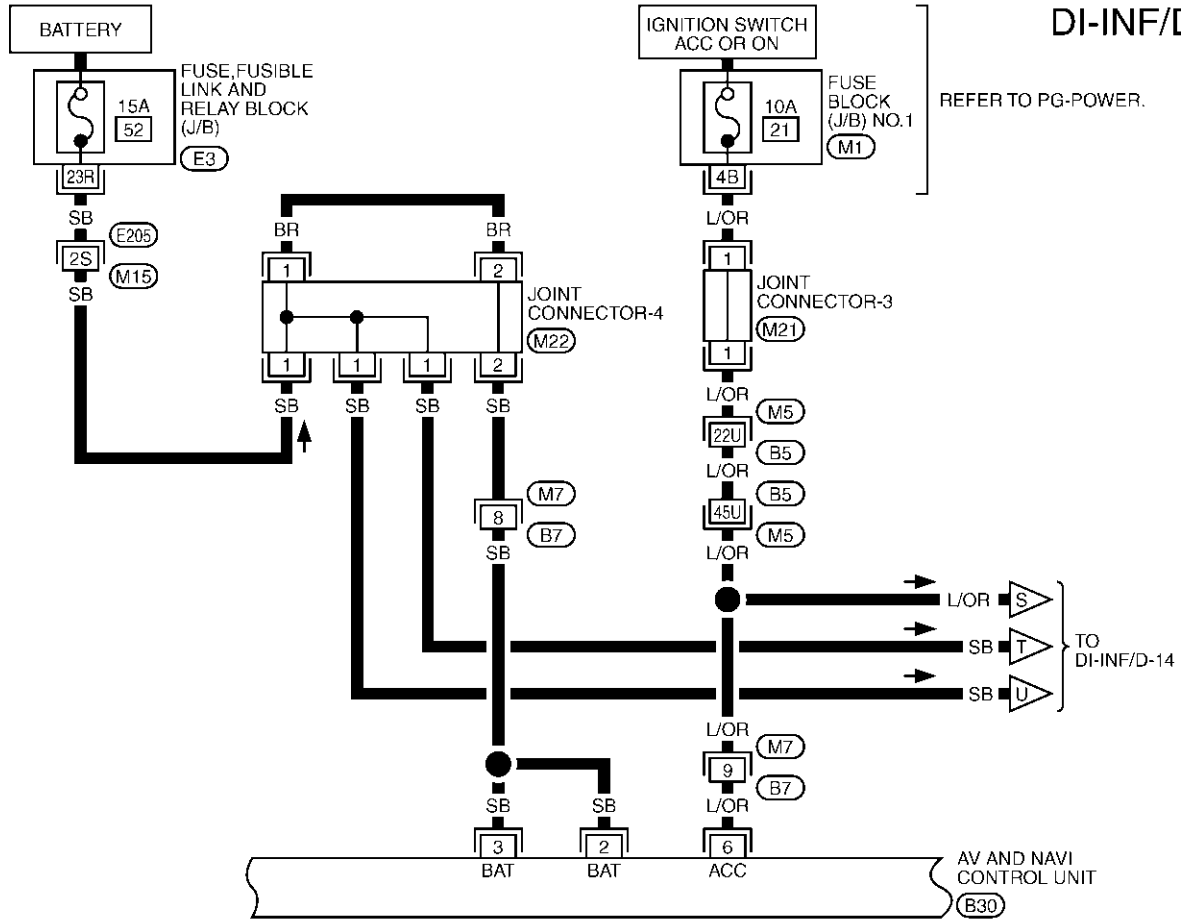

REFER TO PG-POWER.

TO DI-INF/D-14

AV AND NAVI CONTROL UNIT (B30)

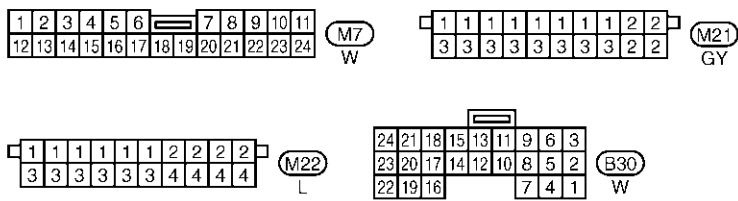

REFER TO THE FOLLOWING.

- (M5), (E205) -SUPER MULTIPLE JUNCTION (SMJ)
- (M1) -FUSE BLOCK-JUNCTION BOX (J/B) NO.1
- (E3) -FUSE,FUSIBLE LINK AND RELAY BLOCK (J/B)

TKWM0733E

VEHICLE INFORMATION AND INTEGRATED SWITCH SYSTEM /WITH NAVIGATION SYSTEM

DI-INF/D-13

A
B
C
D
E
F
G
H
I
J
DI
L
M

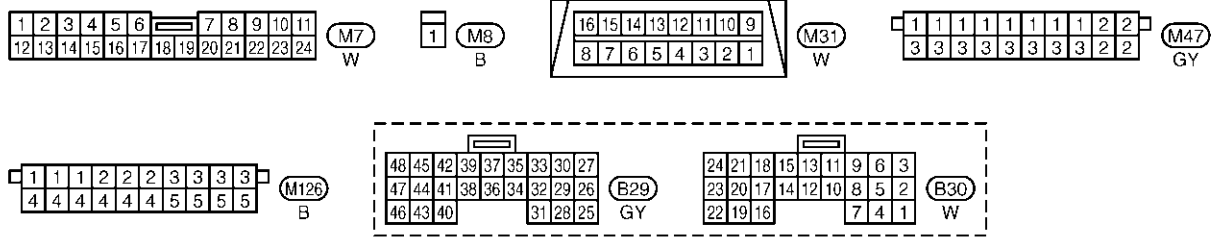
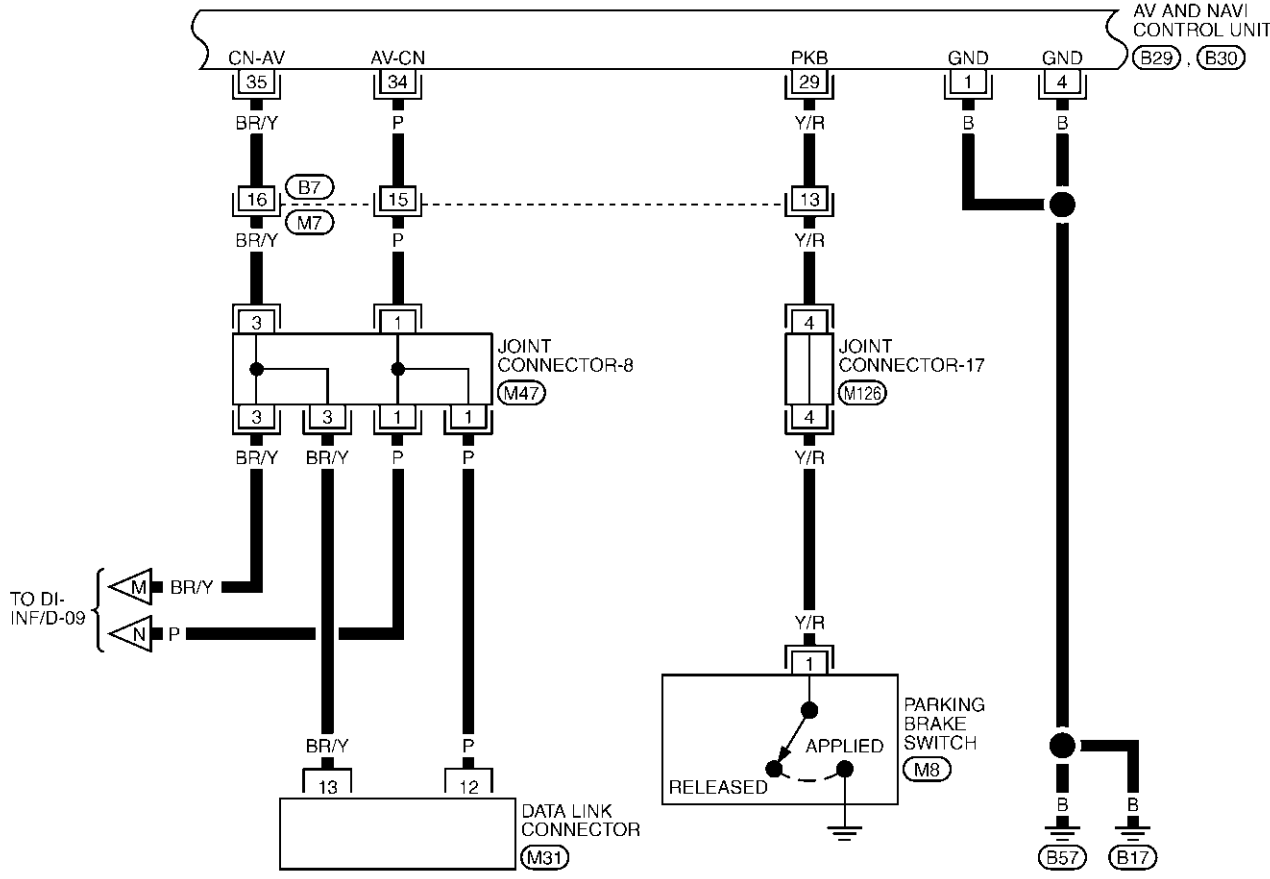

TKWM0734E

VEHICLE INFORMATION AND INTEGRATED SWITCH SYSTEM /WITH NAVIGATION SYSTEM

DI-INF/D-14

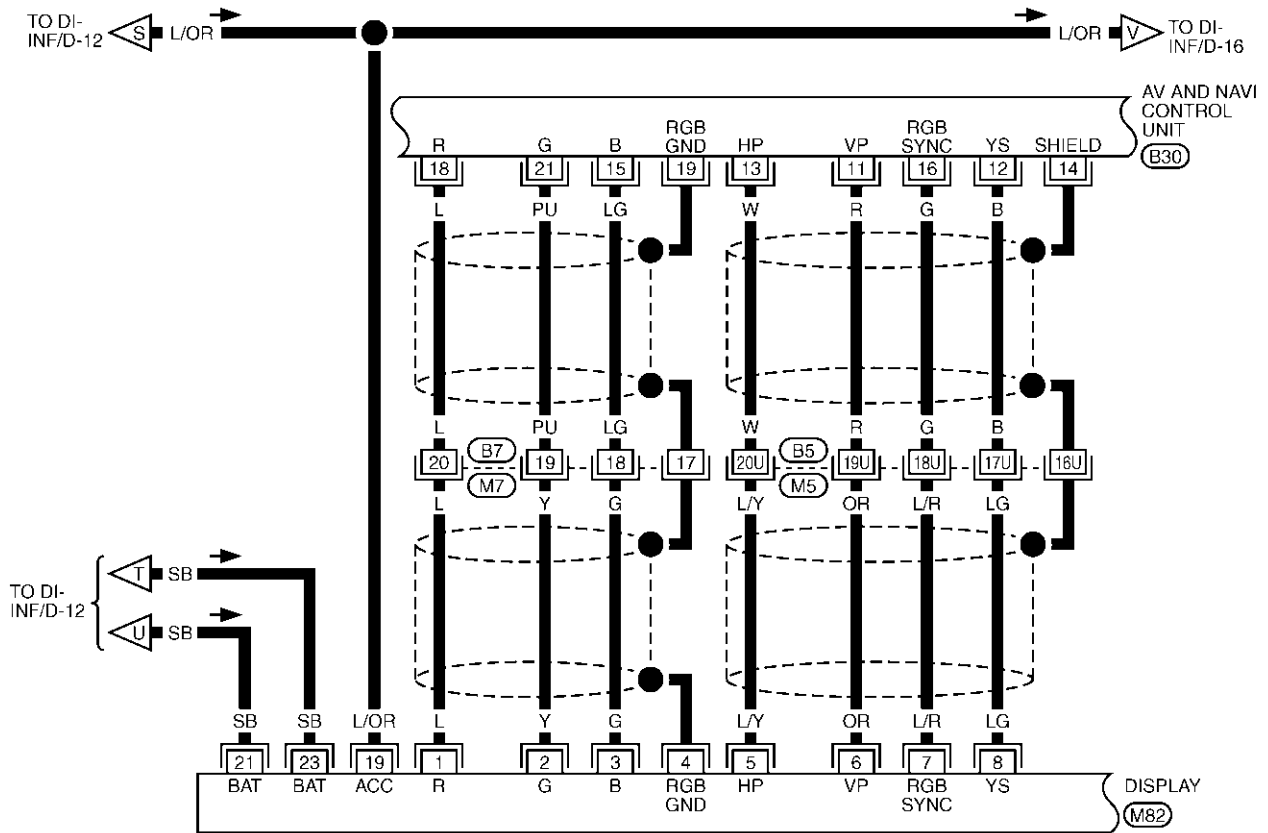

1	2	3	4	5	6	7	8	9	10	11		
12	13	14	15	16	17	18	19	20	21	22	23	24

(M7) W

24	22	20	18	16	14	10	8	6	4	2		
23	21	19	17	15	13	12	11	9	7	5	3	1

(M82) GY

24	21	18	15	13	11	9	6	3
23	20	17	14	12	10	8	5	2
22	19	16			7	4	1	

(B30) W

REFER TO THE FOLLOWING.

(M5) -SUPER MULTIPLE JUNCTION (SMJ)

TKWM0735E

VEHICLE INFORMATION AND INTEGRATED SWITCH SYSTEM /WITH NAVIGATION SYSTEM

DI-INF/D-15

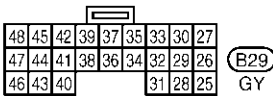
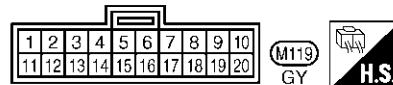
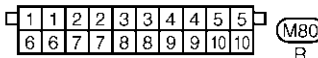
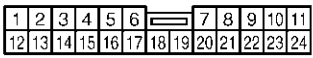
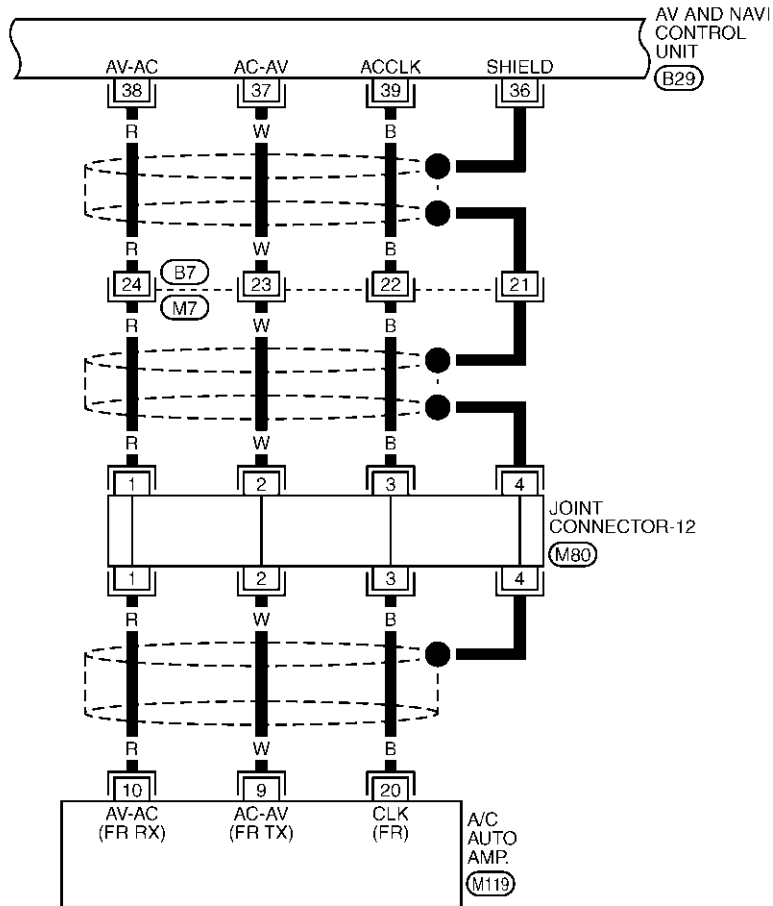

A
B
C
D
E
F
G
H
I
J
DI
L
M

TKWM0736E

VEHICLE INFORMATION AND INTEGRATED SWITCH SYSTEM /WITH NAVIGATION SYSTEM

DI-INF/D-16

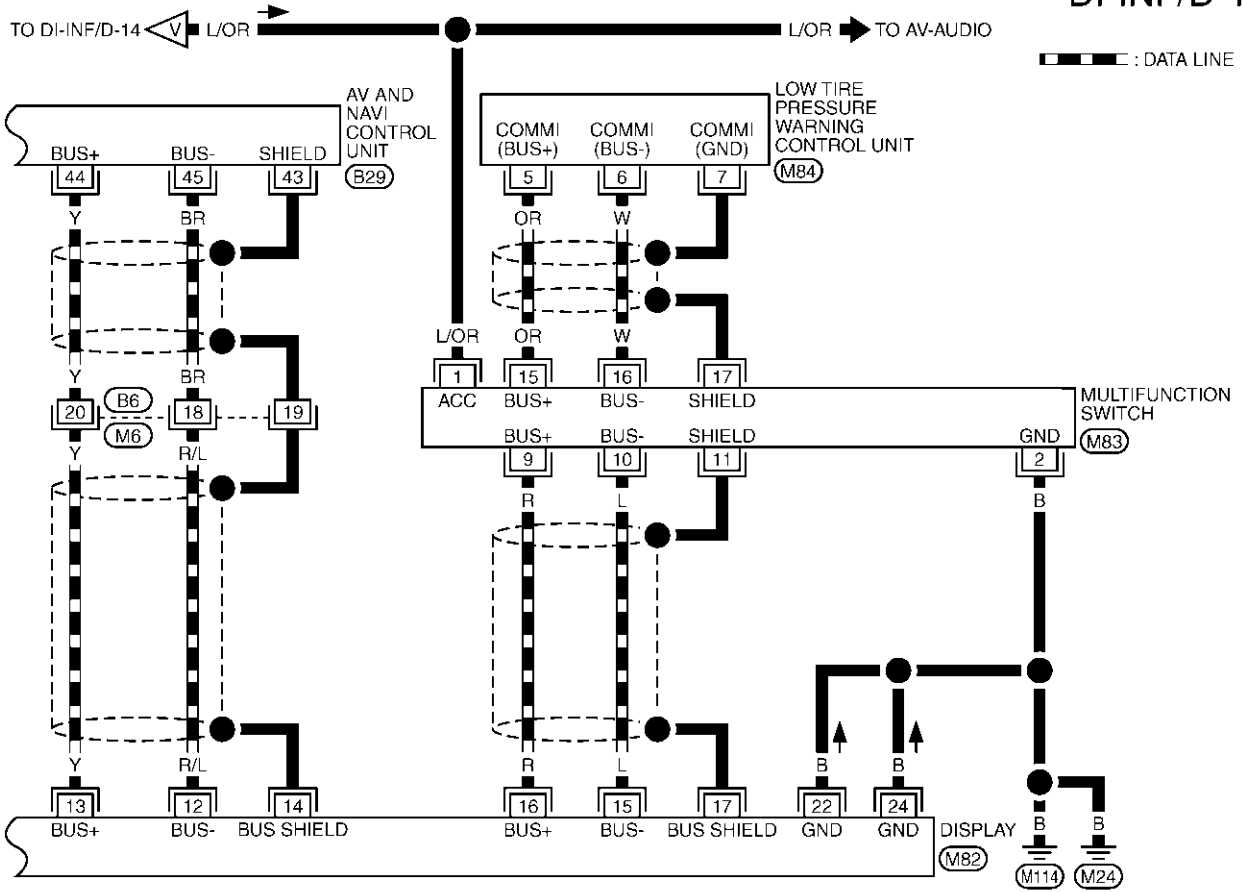

1	2	3	4	5	6	7	8	9	10	11		
12	13	14	15	16	17	18	19	20	21	22	23	24

(M6) GY

24	22	20	18	16	14	10	8	6	4	2		
23	21	19	17	15	13	12	11	9	7	5	3	1

(M82) GY

20	18	16	14	12	8	6	4	2		
19	17	15	13	11	10	9	7	5	3	1

(M83) W

7	6	5	4	3	2	1		
16	15	14	13	12	11	10	9	8

(M84) W

48	45	42	39	37	35	33	30	27
47	44	41	38	36	34	32	29	26
46	43	40				31	28	25

(B29) GY

TKWM0737E

VEHICLE INFORMATION AND INTEGRATED SWITCH SYSTEM /WITH NAVIGATION SYSTEM

Terminals and Reference Value for AV and NAVI Control Unit

EKS006EJ

Refer to [AV-74, "Terminals and Reference Value for AV and NAVI Control unit"](#) .

Terminals and Reference Value for Display

EKS006TT

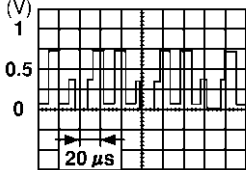
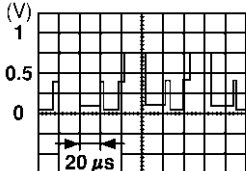
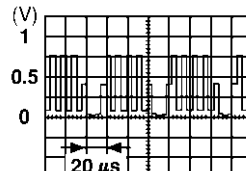
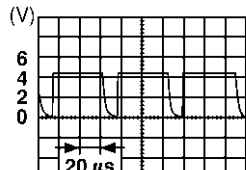
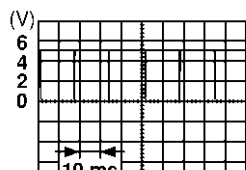
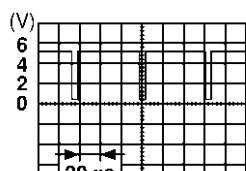
Terminals			Signal	Condition		Reference value (V)
(+)		(-)		Ignition switch	Operation	
Terminal No.	Wire color					
1	L	Ground	RGB signal (R: Red)	ON	Move to "Screen Adjustment" in the check/adjustment function.	 <p style="text-align: right;">SKIA0165E</p>
2	Y	Ground	RGB signal (G: Green)	ON	Move to "Screen Adjustment" in the check/adjustment function.	 <p style="text-align: right;">SKIA0166E</p>
3	G	Ground	RGB signal (B: Blue)	ON	Move to "Screen Adjustment" in the check/adjustment function.	 <p style="text-align: right;">SKIA0167E</p>
4	—	Ground	RGB ground	ON	—	Approx. 0
5	L/Y	Ground	Horizontal synchronizing signal	ON	ON screen, the volume can be adjusted.	 <p style="text-align: right;">SKIA0163E</p>
6	OR	Ground	Vertical synchronizing signal	ON	—	 <p style="text-align: right;">SKIA0161E</p>
7	L/R	Ground	RGB synchronizing signal	ON	Press the map switch.	 <p style="text-align: right;">SKIA0164E</p>

VEHICLE INFORMATION AND INTEGRATED SWITCH SYSTEM /WITH NAVIGATION SYSTEM

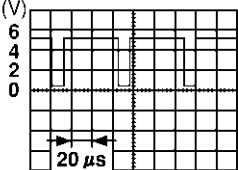
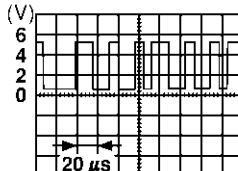
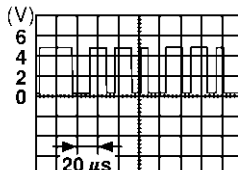
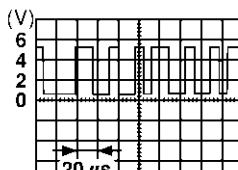
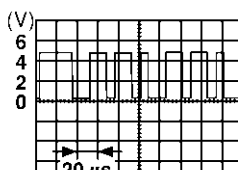
Terminals			Signal	Condition		Reference value (V)
(+)		(-)		Ignition switch	Operation	
Terminal No.	Wire color					
8	LG	Ground	RGB area signal	ON	Press the vehicle information switch.	 <small>SKIA0162E</small>
12	R/L	Ground	Communication signal (-)	ON	—	 <small>SKIA0176E</small>
13	Y	Ground	Communication signal (+)	ON	—	 <small>SKIA0175E</small>
14	—	—	Shield ground	—	—	—
15	L	Ground	Communication signal (-)	ON	—	 <small>SKIA0176E</small>
16	R	Ground	Communication signal (+)	ON	—	 <small>SKIA0175E</small>
17	—	Ground	Shield ground	—	—	—
19	L/OR	Ground	Ignition switch (ACC)	ACC	—	Battery voltage
21	SB	Ground	Battery power	OFF	—	Battery voltage
23	SB					
22	B	Ground	Ground	—	—	—
24	B					

VEHICLE INFORMATION AND INTEGRATED SWITCH SYSTEM /WITH NAVIGATION SYSTEM

Terminals and Reference Value for Multifunction Switch

EKS006TU

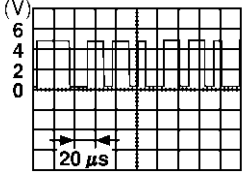
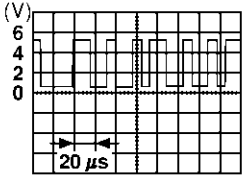
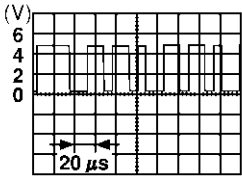
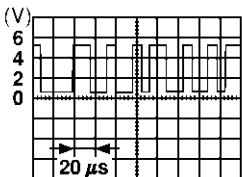
Terminals			Signal	Condition		Reference value (V)
(+)		(-)		Ignition switch	Operation	
Terminal No.	Wire color					
1	L/OR	Ground	Ignition switch (ACC)	ACC	—	Battery voltage
2	B	Ground	Ground	ON	—	Approx. 0
9	R	Ground	Communication signal (+)	ON	—	 <p style="text-align: right; font-size: small;">SKIA0175E</p>
10	L	Ground	Communication signal (-)	ON	—	 <p style="text-align: right; font-size: small;">SKIA0176E</p>
11	—	Ground	Shield ground	ON	—	—
15	OR	Ground	Communication signal (+)	ON	—	 <p style="text-align: right; font-size: small;">SKIA0175E</p>
16	W	Ground	Communication signal (-)	ON	—	 <p style="text-align: right; font-size: small;">SKIA0176E</p>
17	—	Ground	Shield ground	—	—	—

A
B
C
D
E
F
G
H
I
J
DI
L
M

On Board Self-Diagnosis Function DESCRIPTION

EKS006EK

- Diagnosis function consists of the self-diagnosis mode performed automatically and the CONFIRMATION/ADJUSTMENT mode operated manually.
- Self-diagnosis mode checks for connections between the units constituting this system, analyzes each individual unit at the same time, and displays the results on the LCD screen.
- CONFIRMATION/ADJUSTMENT mode is used to perform trouble diagnosis that require operation and judgment by an operator (trouble that cannot be automatically judged by the system), to check/change the set value, and to display the History of Errors of the navigation system.

DIAGNOSIS ITEM

Mode		Description	
Self-diagnosis		<ul style="list-style-type: none"> ● AV and NAVI Control unit diagnosis (DVD-ROM drive will not be diagnosed when no map DVD-ROM is in it.) ● Analyzes connection between the AV and NAVI control unit and the GPS antenna connection between the AV and NAVI control unit and each unit, and operation of each unit. 	
CONFIRMATION/ ADJUSTMENT	Display diagnosis	Color tone and shading of the screen can be checked by the display of a color bar and a gray scale.	
	Vehicle signals	Analyzes the following vehicle signals: Vehicle speed signal, parking brake signal, light signal, ignition switch signal, and reverse signal.	
	Speaker Test	Checks the connection of each speaker using a test tone.	
	Auto Climate Control	Turns all A/C screens on display and A/C switch indicator lamp on.	
	Navigation	Display Longitude & Latitude	Display the map. Use the joystick to adjust position. Longitude and latitude will be displayed.
		Speed Calibration	Under ordinary conditions, the navigation system distance measuring function will automatically compensate for minute decreases in wheel and tire diameter caused by tire wear or low pressure. Speed calibration immediately restores system accuracy in cases such as when distance calibration is needed because of the use of tire chains in inclement weather.
		Angle Adjustment	Corrects difference between actual turning angle of a vehicle and turning angle of the car mark on the display.
		Initialize Location	This mode is for initializing the current location. Use when the vehicle is transported a long distance on a trailer, etc.
	History of Errors		Diagnosis results previously stored in the memory (before turning ignition switch ON) are displayed in this mode. Time and location when/where the errors occurred are also displayed.
Rear View Camera		Changes position of the aiming line overlapped on the rear view image.	

Self-Diagnosis Mode

EKS006EL

Refer to [DI-109, "Self-Diagnosis Mode"](#) .

Confirmation/Adjustment Mode

EKS006EM

Refer to [DI-113, "Confirmation/Adjustment Mode"](#) .

CONSULT-II Function

EKS006EN

Refer to [DI-116, "CONSULT-II Function"](#) .

Multifunction Switch Self-Diagnosis Function

EKS006TV

It can check ON/OFF operation of each switch in the multifunction switch and diagnose the input signals to the rear control switch (audio) and steering switch (audio).

STARTING THE SELF-DIAGNOSIS MODE

1. Turn ignition switch from OFF to ACC.
2. Within 10 seconds press and hold the function switches "1" and "6" simultaneously for 5 seconds.

Then the self-diagnosis operates.

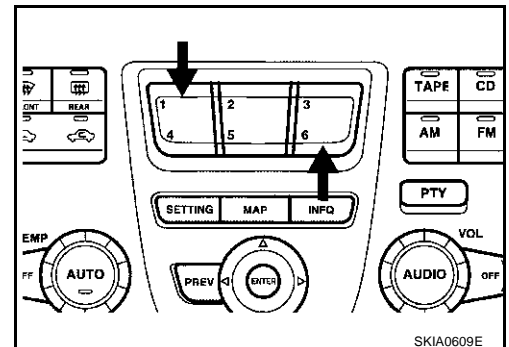

EXITING THE SELF-DIAGNOSIS MODE

- Turn ignition switch OFF, or press and hold the function switches "1" and "6" simultaneously for 5 seconds. Then the self-diagnosis ends.

DIAGNOSIS FUNCTION

- It can illuminate all the indicators (LED) in the multifunction switch.
- It can check for continuity of the switches by sounding the buzzer when the multifunction switch is pressed.
- It can check for continuity of harness between multifunction switch and rear control switch (audio), or steering switch (audio).

NOTE:

When it check continuity of harness between multifunction switch and rear control switch (audio), rear control cancel switch is OFF position.

Power Supply and Ground Circuit Check for AV and NAVI Control Unit

EKS006TY

Refer to [AV-93, "Power Supply and Ground Circuit Check"](#).

Power Supply and Ground Circuit Inspection for Display

1. CHECK FUSES

Check 15A fuse [No. 52, located in fuse, fusible link and relay block (J/B)] is blown.

OK or NG

OK >> GO TO 2.

NG >> If fuse is blown, be sure to eliminate cause of malfunction before installing new fuse. Refer to [PG-2, "POWER SUPPLY ROUTING"](#).

2. CHECK POWER SUPPLY CIRCUIT

1. Disconnect display connector.
2. Check voltage between display harness connector M82 terminals 19 (L/OR), 21 (SB), 23 (SB) and ground.

Terminals		Ignition switch position			
(+)		(-)	OFF	ACC	ON
Connector	Terminal (Wire color)				
M82	19 (L/OR)	Ground	0V	Battery voltage	Battery voltage
	21 (SB)	Ground	Battery voltage	Battery voltage	Battery voltage
	23 (SB)	Ground	Battery voltage	Battery voltage	Battery voltage

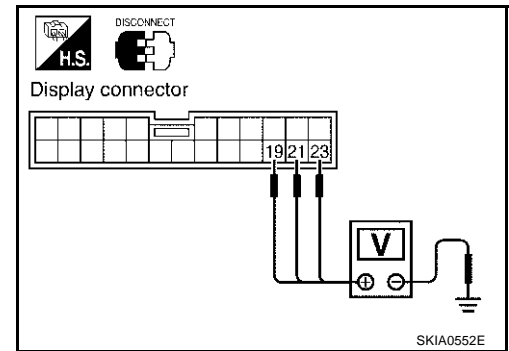

OK or NG

OK >> GO TO 3.

NG >> Check harness for open or short between display and fuse.

3. CHECK GROUND CIRCUIT

Check continuity between display harness connector M82 terminal 22, 24 and ground.

Terminals		(-)	Continuity
(+)			
Connector	Terminal (Wire color)		
M82	22 (B)	Ground	Yes
M82	24 (B)	Ground	Yes

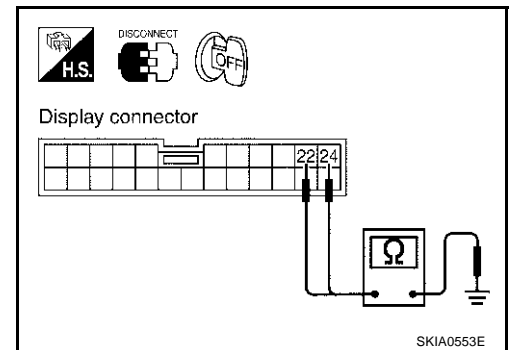

OK or NG

OK >> Inspection end.

NG >> Repair harness or connector.

Power Supply and Ground Circuit Inspection for Multifunction Switch

EKS006U0

1. CHECK POWER SUPPLY CIRCUIT

1. Disconnect multifunction switch connector.
2. Check voltage between multifunction switch harness connector M83 terminal 1 (L/OR) and ground.

Terminals		Ignition switch position			
Connector	(+)	(-)	OFF	ACC	ON
	Terminal (Wire color)				
M83	1 (L/OR)	Ground	0V	Battery voltage	Battery voltage

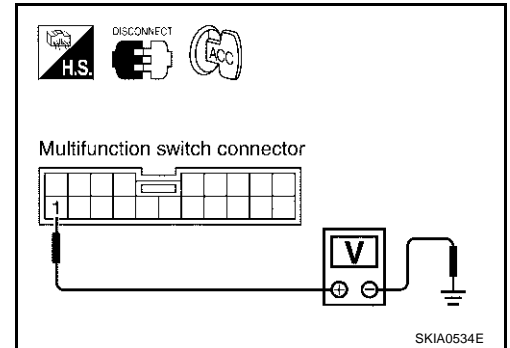

OK or NG

OK >> GO TO 3.

NG >> Check harness for open or short between multifunction switch and fuse.

2. CHECK GROUND CIRCUIT

Check continuity between multifunction switch harness connector M83 terminal 2 (B) and ground.

Continuity should exist.

OK or NG

OK >> Multifunction switch is OK.

NG >> Repair harness or connector.

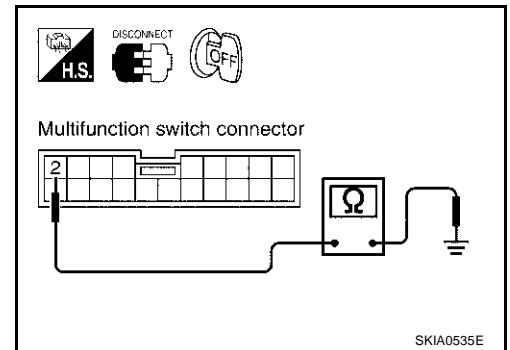

A
B
C
D
E
F
G
H
I
J
DI
L
M

No Fuel Information Is Displayed/No Warning Message Is Displayed

1. CHECK HARNESS

1. Turn the ignition switch OFF.
2. Disconnect connectors of combination meter, BCM, and AV and NAVI control unit.
3. Check continuity between AV and NAVI control unit and combination meter.

Terminals				Continuity
AV and NAVI control unit (+)		Combination meter (-)		
Connector	Terminal (Wire color)	Connector	Terminal (Wire color)	
B29	33 (LG)	M41	7 (LG)	YES
B29	32 (PU)	M41	6 (PU)	YES

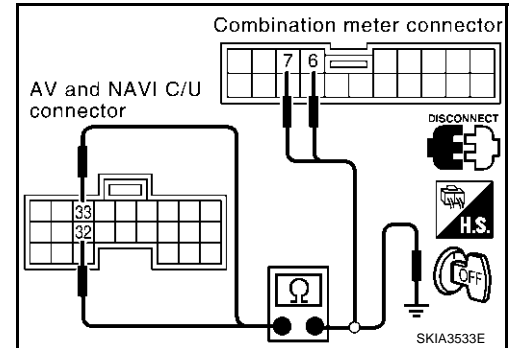

4. Check continuity between AV and NAVI control unit and ground.

Terminals			Continuity
AV and NAVI control unit (+)		(-)	
Connector	Terminal (Wire color)		
B29	33 (LG)	Ground	NO
	32 (PU)		

OK or NG

- OK >> GO TO 2.
 NG >> Repair harness.

2. CHECK COMMUNICATION SIGNAL (AV-ME)

1. Connect connectors of combination meter, BCM, and AV and NAVI control unit.
2. Turn the ignition switch ON.
3. Check the signal between AV and NAVI control unit harness connector B29 terminal 33 (LG) and ground with CONSULT-II or oscilloscope.

33 (LG) – Ground : Refer to [AV-74, "Terminals and Reference Value for AV and NAVI Control unit"](#) .

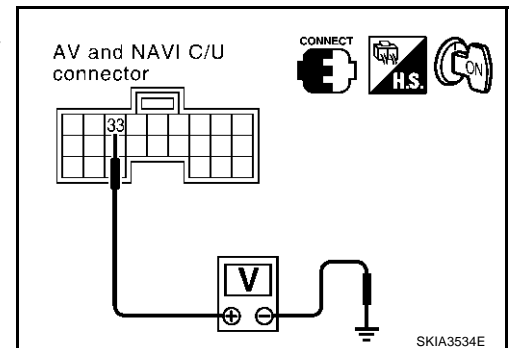

OK or NG

- OK >> GO TO 3.
 NG >> Replace AV and NAVI control unit

3. CHECK COMMUNICATION SIGNAL (ME-AV)

1. Turn ignition switch to ON and display "VEHICLE ELECTRONIC SYSTEMS" screen.
2. Check the signal between AV and NAVI control unit harness connector B29 terminal 32(PU) and ground with CONSULT-II or oscilloscope.

32 (PU) – Ground : Refer to [AV-74, "Terminals and Reference Value for AV and NAVI Control unit"](#) .

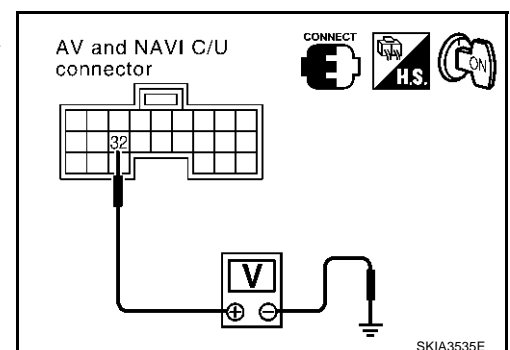

OK or NG

- OK >> Replace AV and NAVI control unit.
 NG >> Replace combination meter,.

Vehicle Condition Setting Is Not Possible

1. CHECK HARNESS

1. Turn the ignition switch OFF.
2. Disconnect connectors of combination meter, BCM, and AV and NAVI control unit.
3. Check continuity AV and NAVI control unit and BCM.

Terminals				Continuity
AV and NAVI control unit (+)		BCM (-)		
Connector	Terminal (Wire color)	Connector	Terminal (Wire color)	
B29	33 (LG)	M4	31 (LG)	YES
B29	32 (PU)	M4	30 (PU)	YES

4. Check continuity between AV and NAVI control unit and ground.

Terminals			Continuity
AV and NAVI control unit (+)		(-)	
Connector	Terminal (Wire color)		
B29	33 (LG)	Ground	NO
	32 (PU)		

OK or NG

- OK >> GO TO 2.
 NG >> Repair harness.

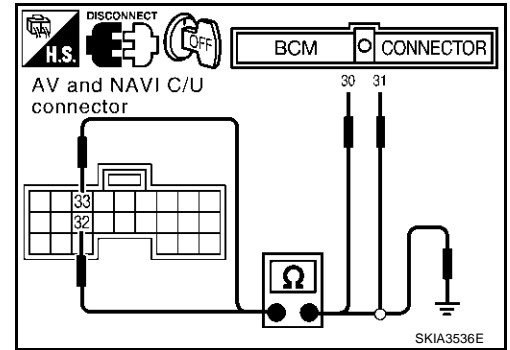

2. CHECK COMMUNICATION SIGNAL (AV-ME)

1. Connect connectors of combination meter, BCM, and AV and NAVI control unit.
2. Turn the ignition switch ON.
3. Check the signal between AV and NAVI control unit harness connector B29 terminal 33 (LG) and ground with CONSULT-II or oscilloscope.

33 (LG) – Ground : Refer to [AV-74, "Terminals and Reference Value for AV and NAVI Control unit"](#) .

OK or NG

- OK >> GO TO 3.
 NG >> Replace AV and NAVI control unit

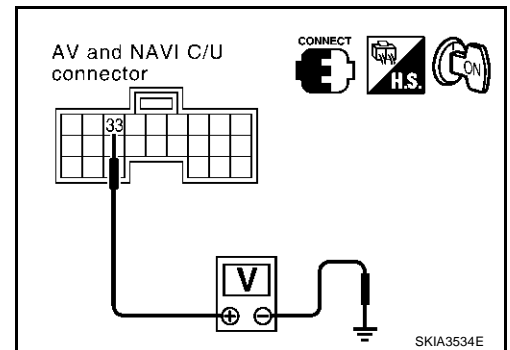

3. CHECK COMMUNICATION SIGNAL (ME-AV)

1. Turn ignition switch to ON and display "VEHICLE ELECTRONIC SYSTEMS" screen.
2. Check the signal between AV and NAVI control unit harness connector B29 terminal 32 (PU) and ground with CONSULT-II or oscilloscope.

32 (PU) – Ground : Refer to [AV-74, "Terminals and Reference Value for AV and NAVI Control unit"](#) .

OK or NG

- OK >> Replace AV and NAVI control unit.
 NG >> Replace BCM.

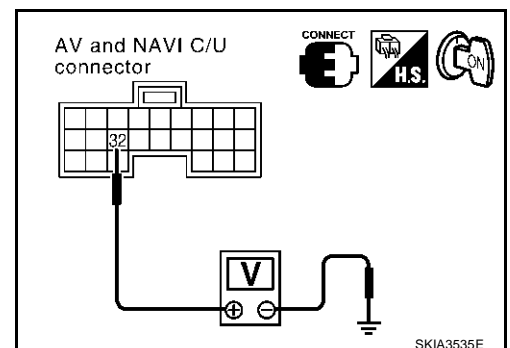

Multifunction Switch Does Not Operate

EKS006ET

Inspection procedure

1. MULTIFUNCTION SWITCH SELF-DIAGNOSIS

Perform multifunction switch self-diagnosis. Refer to [DI-155, "Multifunction Switch Self-Diagnosis Function"](#) .

Is self-diagnosis result OK?

- OK >> GO TO 2.
- NG >> Replace multifunction switch.

2. CHECK POWER AND GROUND CIRCUIT

Check power and ground circuit. Refer to [DI-153, "Terminals and Reference Value for Multifunction Switch"](#) .

OK or NG

- OK >> GO TO 3
- NG >> Repair harness or connector.

3. COMMUNICATION CIRCUIT SELF-DIAGNOSIS

Perform the self-diagnosis mode in the self-diagnosis function (If the self-diagnosis cannot be activated with the multifunction switch, check with CONSULT-II). Refer to [DI-109, "Self-Diagnosis Mode"](#) .

Is self-diagnosis result OK?

- OK >> Replace display
- NG >> With the self-diagnostic results, check the malfunction part.

Multifunction Switch Indicator Does Not illuminate

EKS006EU

1. MULTIFUNCTION SWITCH SELF-DIAGNOSIS

Perform the multifunction switch self-diagnosis. Refer to [DI-155, "Multifunction Switch Self-Diagnosis Function"](#) .

Is the self-diagnosis result OK?

- OK >> Replace switch of the malfunctioning indicator
- NG >> Replace multifunction switch.

Removal and Installation of Display

EKS006EV

REMOVAL

1. Remove the cluster lid C. Refer to [IP-10, "INSTRUMENT PANEL ASSEMBLY"](#)
2. Remove the screws (4), and remove the display.

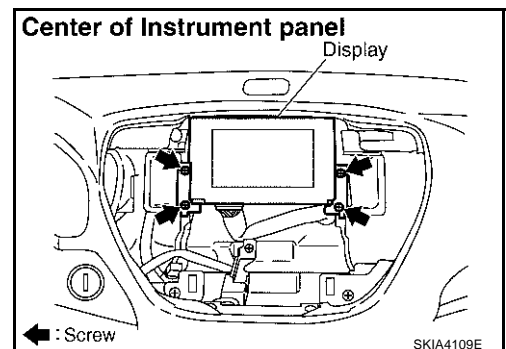

INSTALLATION

Install in the reverse order of removal.

Disassembly and Assembly for Multifunction Switch

EKS006EW

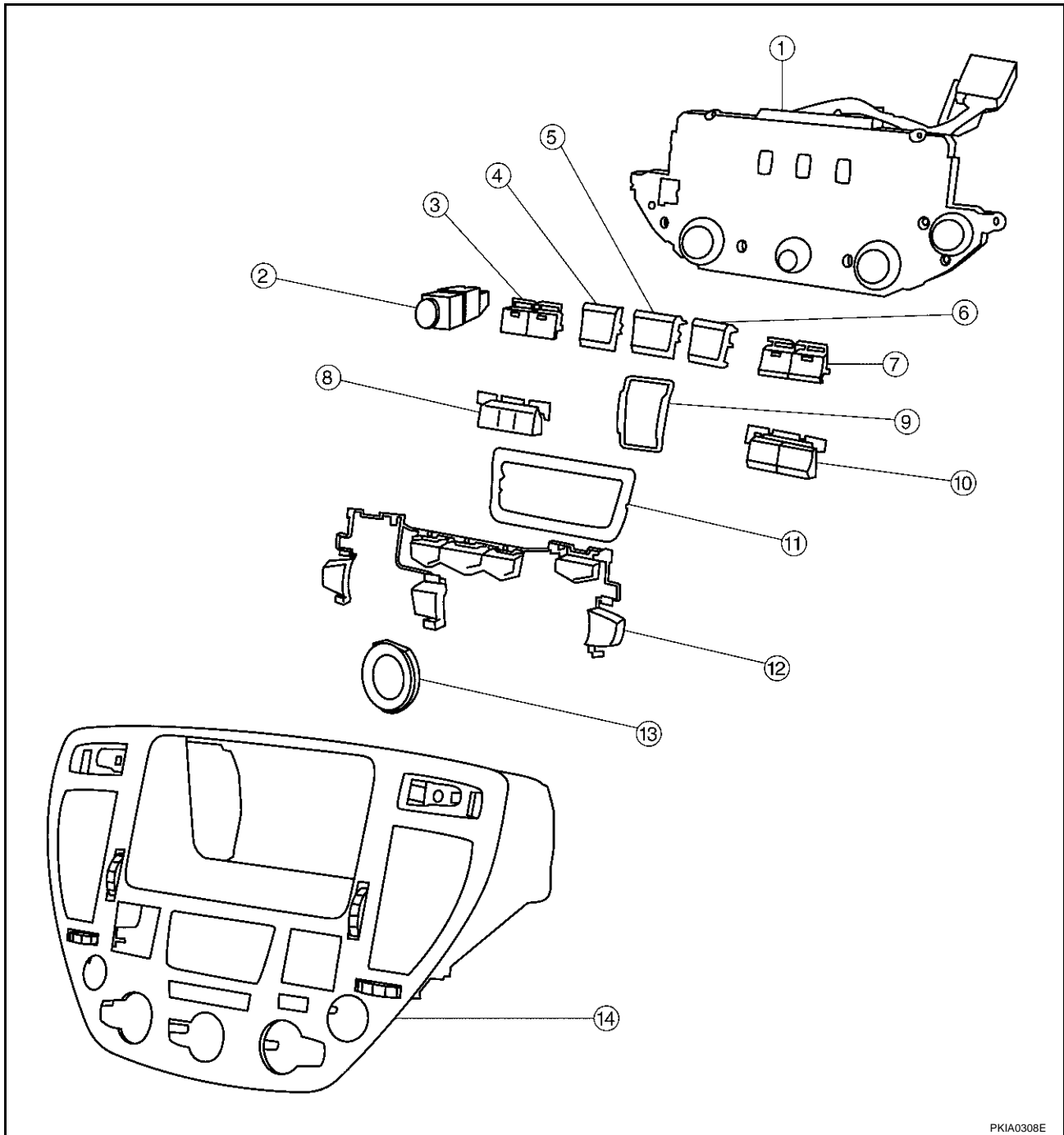

A
B
C
D
E
F
G
H
I
J
DI
L
M

- | | | |
|-------------------------|--------------------|------------------------------------|
| 1. Multifunction switch | 2. Hazard switch | 3. Defroster, rear defogger switch |
| 4. Function switch | 5. Function switch | 6. Function switch |
| 7. TAPE and DISC switch | 8. A/C switch | 9. Escutcheon |
| 10. AM and FM switch | 11. Escutcheon | 12. Switch assembly |
| 13. Escutcheon | 14. Cluster lid C | |

1. Remove the screw (7)
2. Remove the switches.

Removal and Installation of AV and NAVI Control Unit

EKS006EX

REMOVAL

1. Remove the trunk compartment trim. Refer to [EI-52, "TRUNK ROOM TRIM & TRUNK LID FINISHER"](#) .
2. Remove the screws (4) and remove the AV and NAVI control unit.

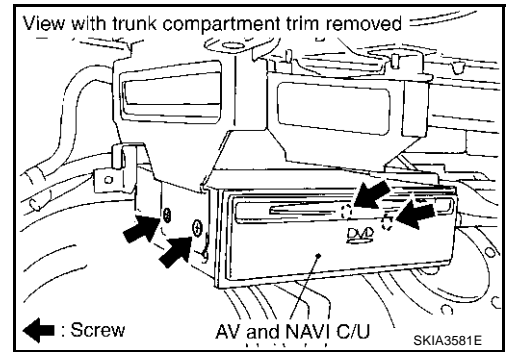

INSTALLATION

Install in the reverse order of removal.

CLOCK

PFP:25820

CLOCK

Wiring Diagram — CLOCK —

EKS001B7

DI-CLOCK-01

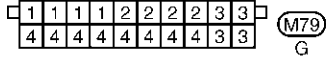
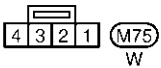
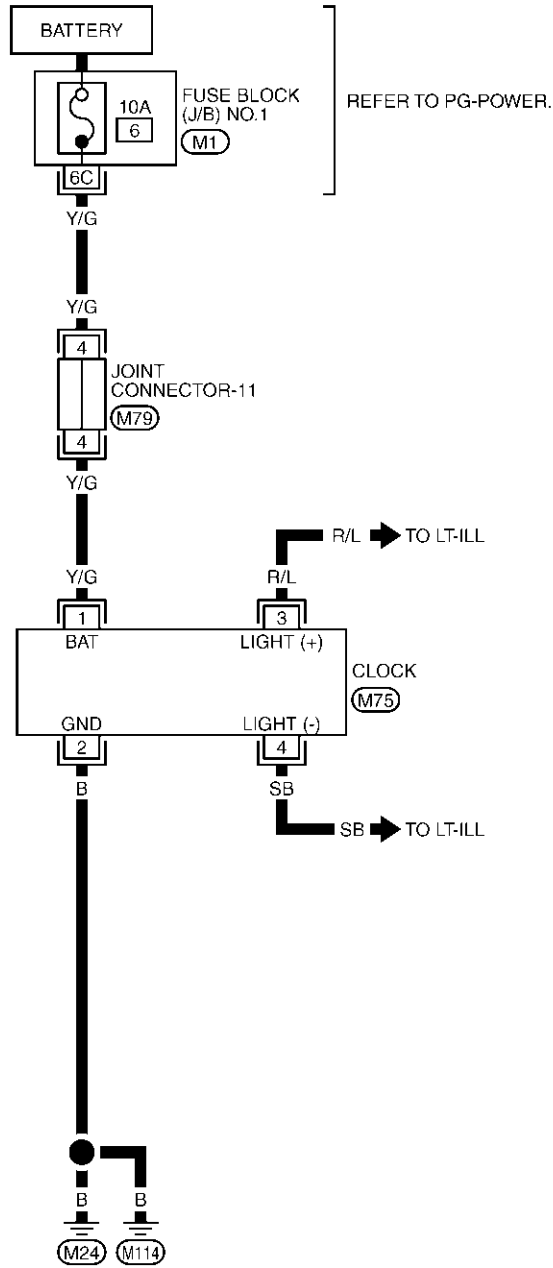

REFER TO THE FOLLOWING.
 (M1) - FUSE BLOCK-JUNCTION BOX (J/B) NO.1

A
B
C
D
E
F
G
H
I
J
DI
L
M

CLOCK

Removal and Installation

EKS001B8

REMOVAL

1. Remove the cluster lid C, refer to [IP-10, "INSTRUMENT PANEL ASSEMBLY"](#)
2. Remove the screws (2), and remove clock.

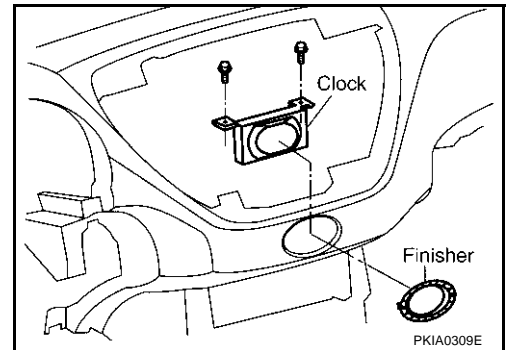

INSTALLATION

Install in the reverse order of removal.

REAR VIEW MONITOR

REAR VIEW MONITOR

PFP:28260

System Description

EKS0012G

- The rear view monitor is equipped to check the rearward of the vehicle with display when A/T selector lever is in reverse position.
- The lines of vehicle sides and the distance from the rear end of the vehicle are provided on display as a guide. It allows the driver to know the distance between the vehicle and a rearward object, and the width of the vehicle much easier.

POWER SUPPLY AND GROUND

Power is supplied at all time

- through 15A fuse [No. 52, located in fuse, fusible link and relay block (J/B)]
- to rear view camera control unit terminal 2.

When ignition switch is ACC or ON position, power is supplied

- through 10A fuse [No. 21, located in fuse block (J/B) No. 1]
- to rear view camera control unit terminal 4.

When Ignition switch is ON or START position, power is supplied

- through 10A fuse [No. 9, located in fuse block (J/B) No. 1]
- to back-up lamp relay terminal 2 and 5.

Ground is supplied

- to rear view camera control unit terminal 1
- through grounds B217 and B256, and
- to rear view camera terminal 2
- through grounds B17 and B57.

AV COMMUNICATION LINE

Rear view camera control unit is connected to the following units with AV communication line. Each unit transmits/receives data with AV communication line.

- AV and NAVI control unit (with navigation system)
- AV control unit (without navigation system)
- Display
- Multifunction switch

REAR VIEW CAMERA OPERATION

When A/T selector lever is reverse position, power is supplied

- through back-up lamp relay terminal 1
- to TCM terminal 41.

Then back-up lamp relay is energized,

- from back-up lamp relay terminal 3
- to rear view camera control unit terminal 10.

Then, rear view camera control unit is sent camera ON signal

- through rear view camera control unit terminal 6
- to rear view camera terminal 1.

An image taken by rear view camera is sent

- through rear view camera terminals 3 and 4
- to rear view camera control unit terminals 18 and 16.

Then an image is sent

- through rear view camera control unit terminals 22 and 24
- to the display terminals 9 and 10.

An image of rear view will be projected on the display.

A
B
C
D
E
F
G
H
I
J

DI

L
M

REAR VIEW MONITOR

Rear View Camera Guide Line

When A/T selector lever is in reverse position, AV and NAVI control unit (with navigation system) or AV control unit (without navigation system) is sent rear view camera guideline signal with AV communication line

- from AV and NAVI control unit terminals 44 and 45 (with navigation system) or AV control unit terminal 47 and 48 (without navigation system)
- through display, multifunction switch, audio unit and audio amp. (Bose speaker amp.)
- to rear view camera control unit terminal 11 and 9.

Then rear view camera control unit is sent rear view camera guideline image

- through rear view camera control unit terminals 22 and 24
- to the display terminals 9 and 10.

Rear view camera guide line will be projected on the display.

Display shows image from rear view camera image and rear view camera guideline.

FUNCTION OF BACKLIGHT CORRECTION

When visibility of rear view image projected on the display is not good caused by backlight, the rear view image projected on the display can be adjusted by pushing "ENTER" button.

When "ENTER" button is pushed, using AV communication line, backlight correction signal is sent

- from multifunction switch terminals 12 and 13
- through BOSE speaker amp. and audio unit
- to rear view camera control unit terminals 11 and 9.

Then, backlight correction signal is sent

- through rear view camera control unit terminal 8
- to rear view camera terminal 5.

An iris function of rear view camera will be operated, and visibility of rear view image projected on the display will be imaged.

Component Parts and Harness Connector Location

EKS0012H

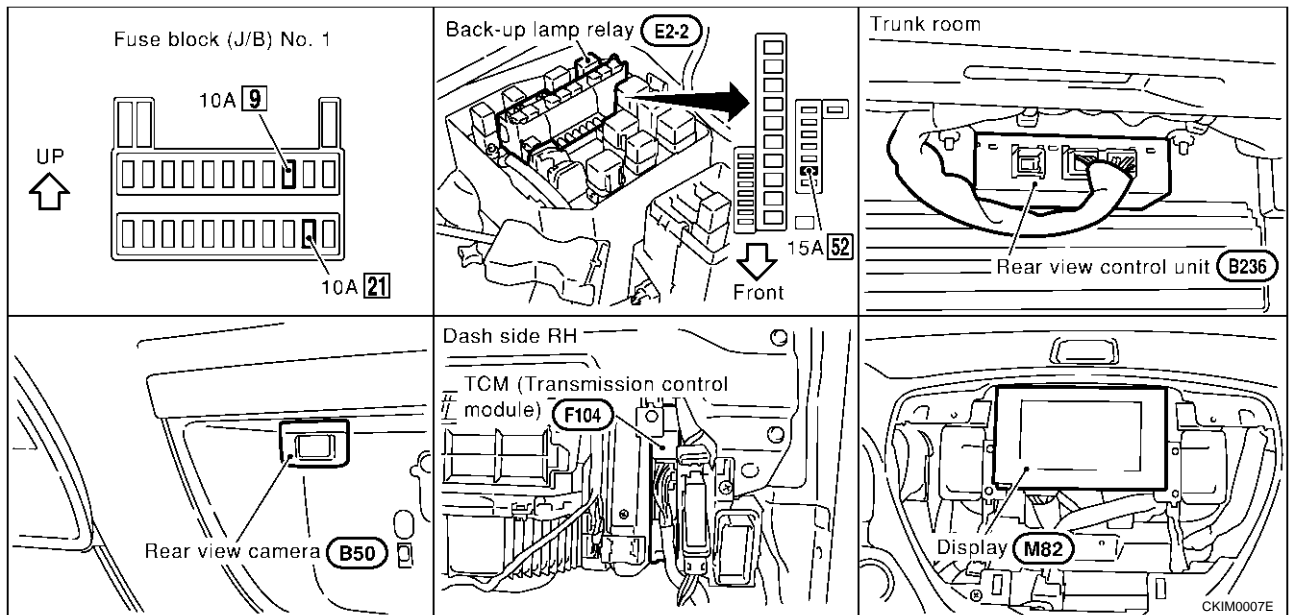

REAR VIEW MONITOR

Schematic

EKS00121

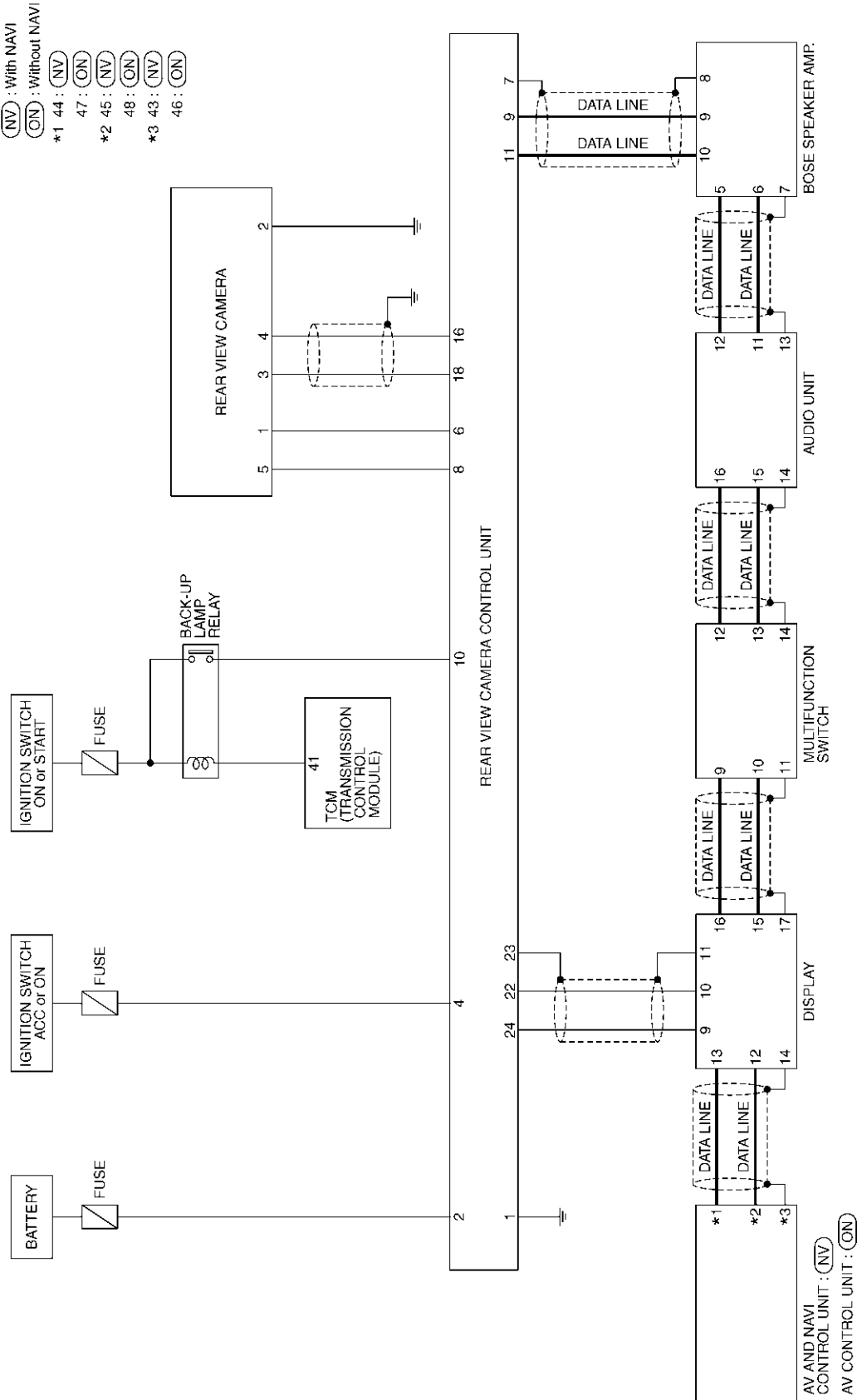

A
B
C
D
E
F
G
H
I
J
K
L
M

DI

REAR VIEW MONITOR

EKS001BY

Wiring Diagram — R/VIEW —

DI-R/VIEW-01

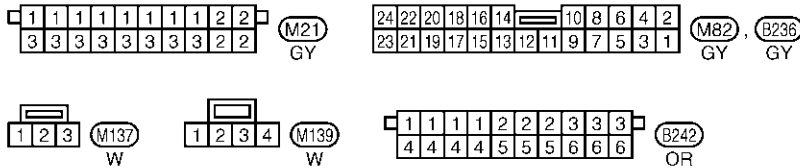
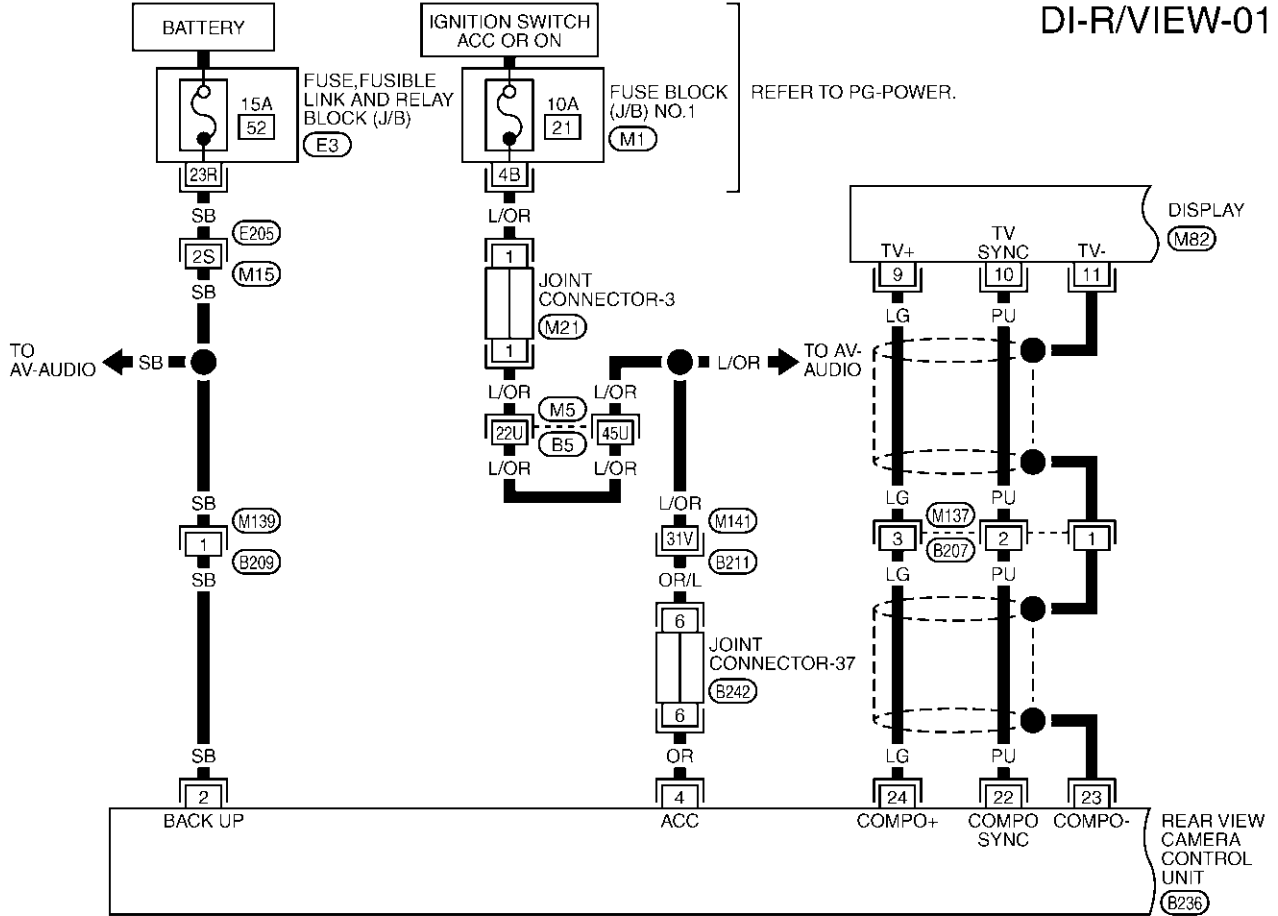

REFER TO THE FOLLOWING.
 (M5), (E205), (B211) -SUPER
 MULTIPLE JUNCTION (SMJ)
 (M1) -FUSE BLOCK-JUNCTION
 BOX (J/B) NO.1
 (E3) -FUSE,FUSIBLE LINK AND
 RELAY BLOCK (J/B)

TKWM0284E

REAR VIEW MONITOR

DI-R/VIEW-02

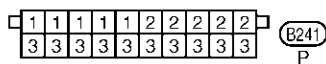
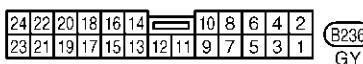
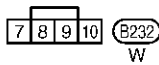
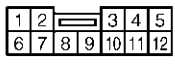
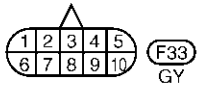
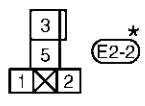
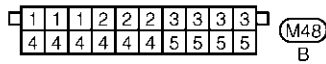
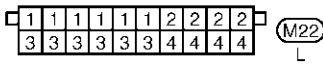
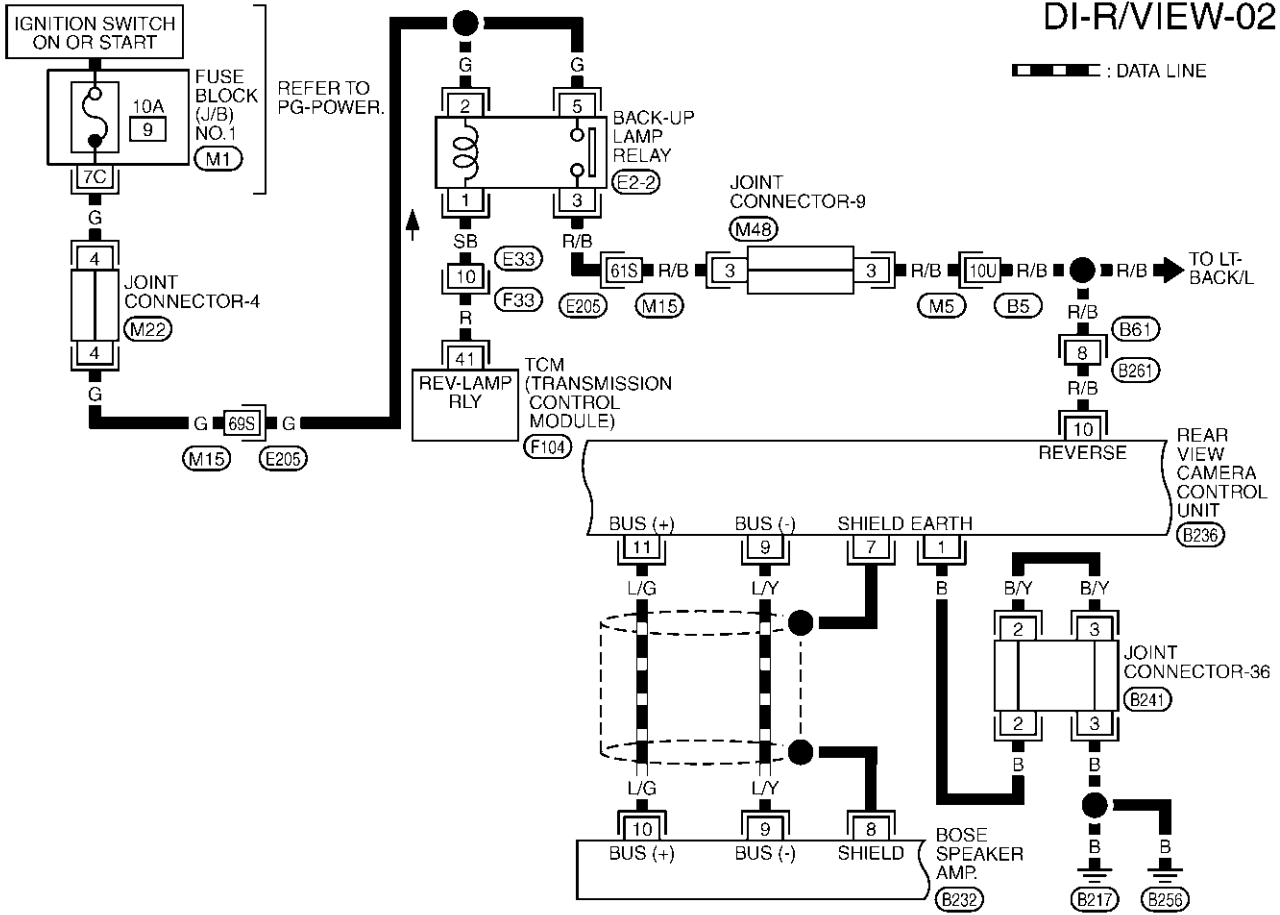

REFER TO THE FOLLOWING.

(M5), (E205) -SUPER MULTIPLE JUNCTION (SMJ)

(M1) -FUSE BLOCK-JUNCTION BOX (J/B) NO.1

(F104) -ELECTRICAL UNITS

*: THIS CONNECTOR IS NOT SHOWN IN "HARNESS LAYOUT", PG SECTION.

TKWM0738E

REAR VIEW MONITOR

DI-R/VIEW-03

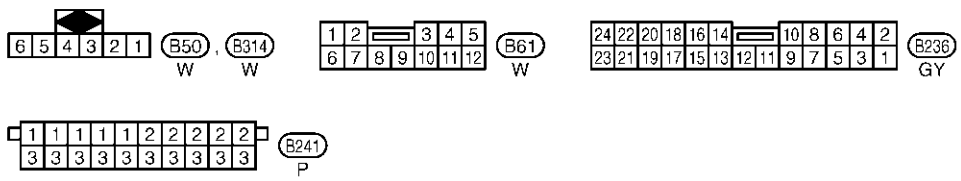
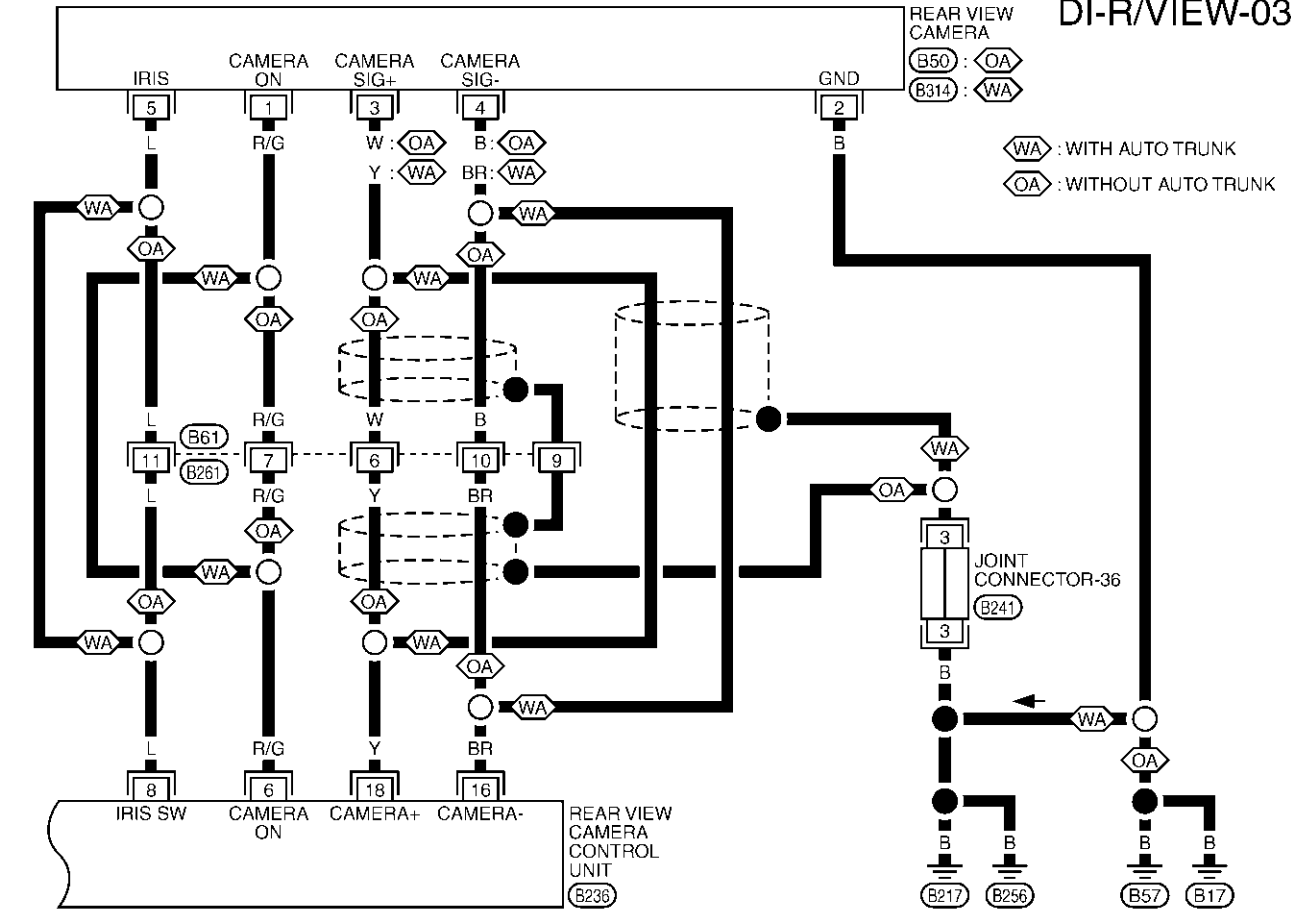

TKWM0739E

REAR VIEW MONITOR

WITHOUT NAVI

DI-R/VIEW-04

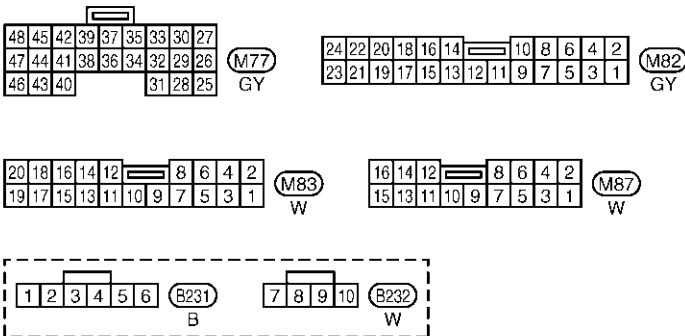
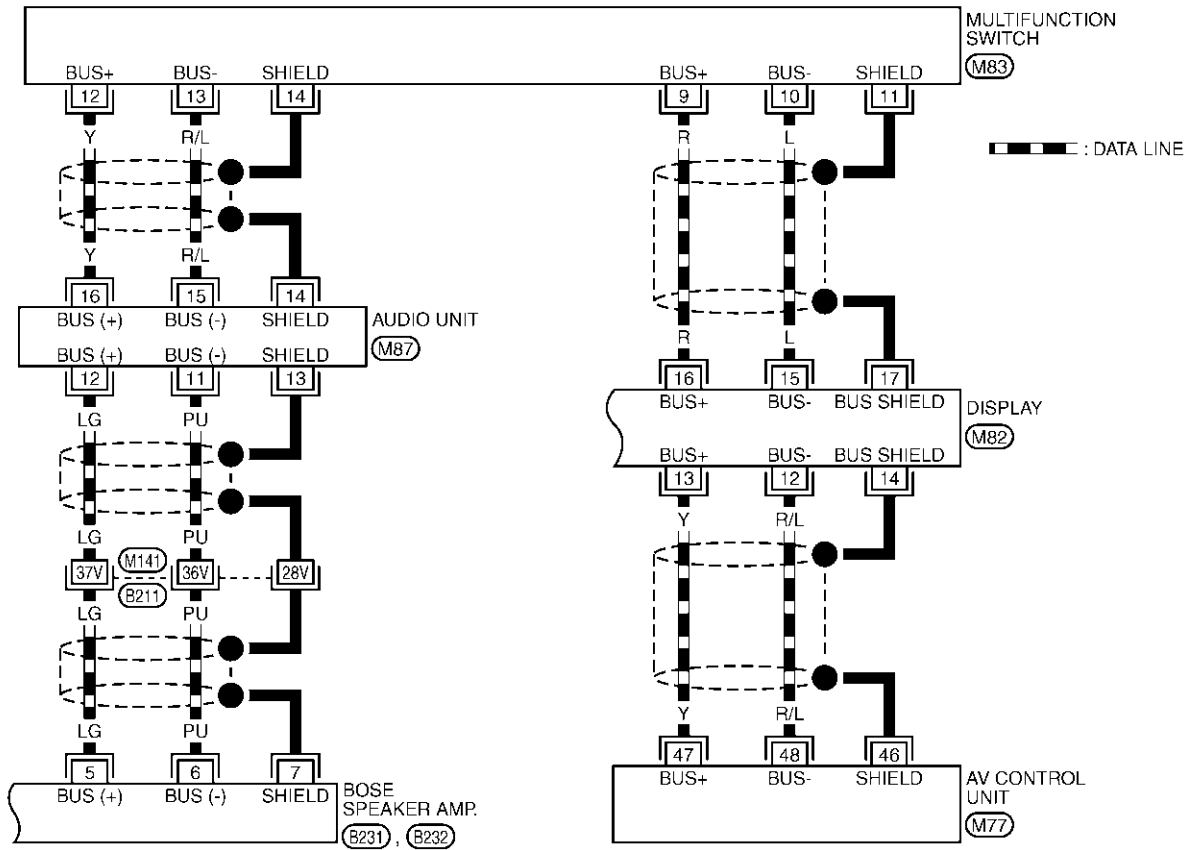

REFER TO THE FOLLOWING.

(B211) -SUPER MULTIPLE JUNCTION (SMJ)

A
B
C
D
E
F
G
H
I
J
DI
L
M

REAR VIEW MONITOR

WITH NAVI

DI-R/VIEW-05

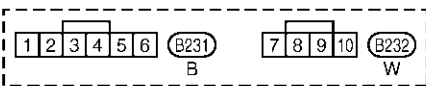
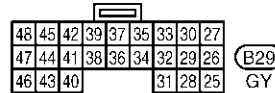
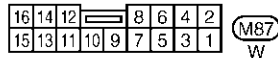
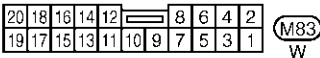
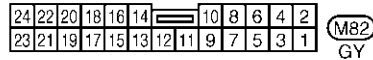
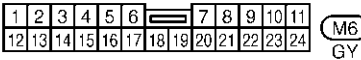
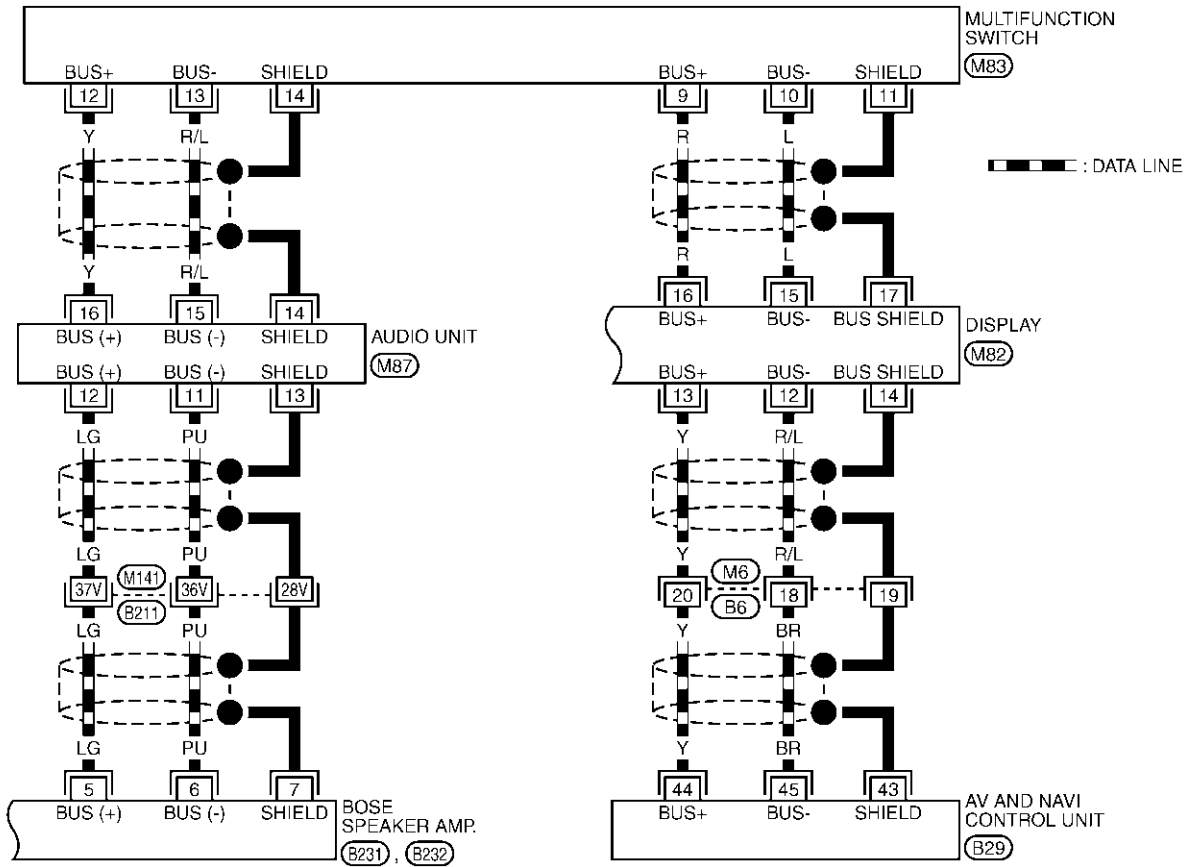

REFER TO THE FOLLOWING.

(B21) -SUPER MULTIPLE JUNCTION (SMJ)

TKWM0391E

REAR VIEW MONITOR

Terminals and Reference Value for Rear View Camera Control Unit

EKS0012J

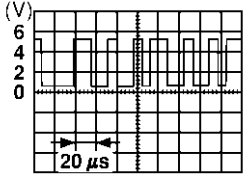
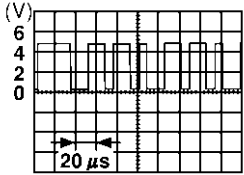
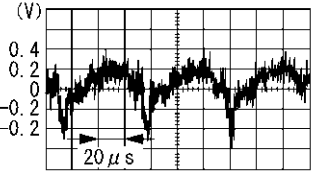
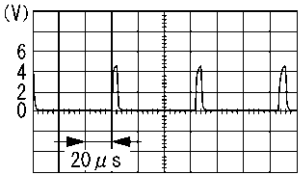
Terminals			Item	Condition		Reference value (V)
(+)		(-)		Ignition switch	Operation	
Terminal No.	Wire color					
1	B	Ground	Ground	ON	—	Approx. 0
2	SB	Ground	Battery Power	OFF	—	Battery voltage
4	OR	Ground	ACC Power	ACC	—	Battery voltage
6	R/G	Ground	Camera Power output	ON	A/T selector lever R-position	Approx. 9
7	—	Ground	Shield ground	ON	—	Approx. 0
8	L	Ground	Iris ON signal	ON	A/T selector lever R-position When the rear view monitor ON: Backlight correction OFF	Approx. 0
					After the above, press the multi-function switch ENTER button: Backlight correction ON	Approx. 9
9	L/Y	Ground	Communication signal (-)	ON	—	 <p style="text-align: right; font-size: small;">SKIA0176E</p>
10	R/B	Ground	Reverse signal input	ON	A/T selector lever R-position	Battery voltage
					A/T selector lever in other than R-position	Approx. 0
11	L/G	Ground	Communication signal (+)	ON	—	 <p style="text-align: right; font-size: small;">SKIA0175E</p>
16	BR	Ground	Camera image input (-)	ON	—	Approx. 0
18	Y	Ground	Camera image input (+)	ON	A/T selector lever R-position	 <p style="text-align: right; font-size: small;">SKIA0186E</p>
22	PU	Ground	Composite image synchronization signal output	ON	A/T selector lever R-position	 <p style="text-align: right; font-size: small;">SKIA0187E</p>

A
B
C
D
E
F
G
H
I
J
DI
L
M

REAR VIEW MONITOR

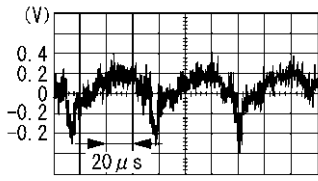
Terminals			Item	Condition		Reference value (V)
(+)		(-)		Ignition switch	Operation	
Terminal No.	Wire color					
23	—	Ground	Shield ground	ON	—	—
24	LG	Ground	Composite image Output	ON	A/T selector lever R-position	

SKIA0186E

Self-Diagnosis Function

EKS0012K

DESCRIPTION

- Diagnosis function has 2 modes; self-diagnosis mode and Confirmation/adjustment mode.
- Self-diagnosis mode checks connections between AV and NAVI control unit and rear view camera control unit, and shows the results on the display screen.
- The Confirmation/Adjustment mode adjusts the guidelines which overlap rear view monitor image.

DIAGNOSIS ITEM

Mode		Description
Self-diagnosis		Check connection between AV&NAVI control unit and rear view camera control unit.
Confirmation/Adjustment	Rearview	It can adjust the guidelines which overlap the rear view monitor image.

Self-Diagnosis Mode

EKS001FE

OPERATION PROCEDURE

- For the starting procedure of the self-diagnosis mode and self-diagnosis results, refer to [DI-109, "Self-Diagnosis Mode"](#) (with navigation system) or [DI-109, "Self-Diagnosis Mode"](#) (without navigation system).

Confirmation/Adjustment Mode

EKS001FF

OPERATION PROCEDURE

1. Start the engine.
2. Turn OFF the audio system.
3. While pressing the "INFO" switch, turn volume control dial clockwise or counterclockwise for 30 clicks or more. (When self-diagnosis mode is activated, a short beep will be heard.)
- To return to the previous screen, press "PREV" switch.

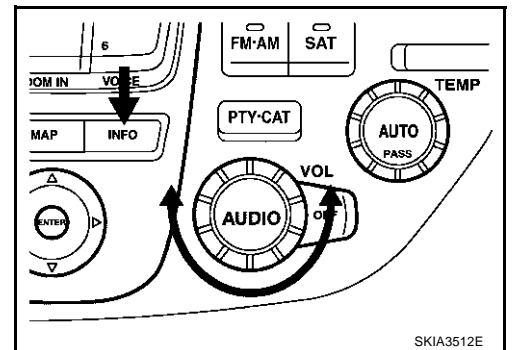

SKIA3512E

4. The initial trouble diagnosis screen is displayed for selecting "self-diagnosis" or "Confirmation/Adjustment" modes.

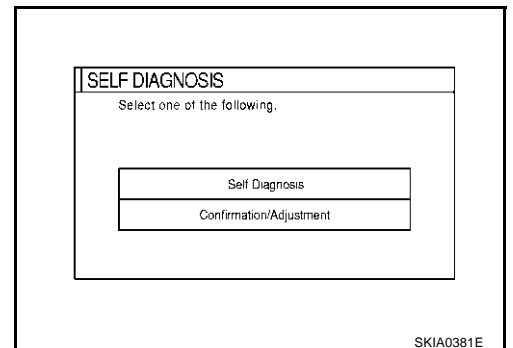

SKIA0381E

REAR VIEW MONITOR

5. Select "confirmation/Adjustment" In this mode, check and adjustment of each item will become possible.
6. Select each switch on the "CONFIRMATION/ADJUSTMENT" screen to display the relevant diagnosis screen.

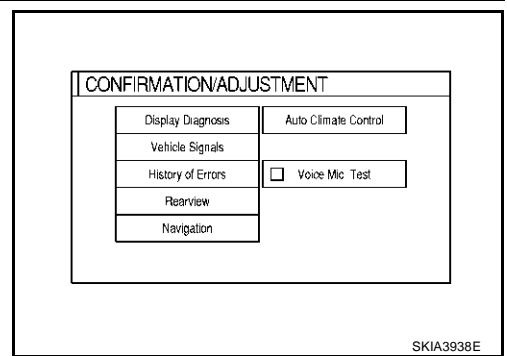

Side Distance Guideline Correction

EKS001FG

- This mode is used to modify the side distance guidelines if they are dislocated from the rear view monitor image, because of variations of body/camera mounting conditions.

Side distance guideline correction procedure

1. Create a correction line to modify the screen.
Draw lines on the rearward of the vehicle passing through the following points: 0.2 m (7.87 inch) from both sides of the vehicle, and
 - *1: 0.45 m (1.5 feet)
 - *2: 0.91 m (3.0 feet)
 - *3: 2.13 m (7.0 feet)
 - *4: 3.04 m (10 feet)
 and from the rear end of the bumper
2. Select "REARVIEW" in "Confirmation/Adjustment mode".

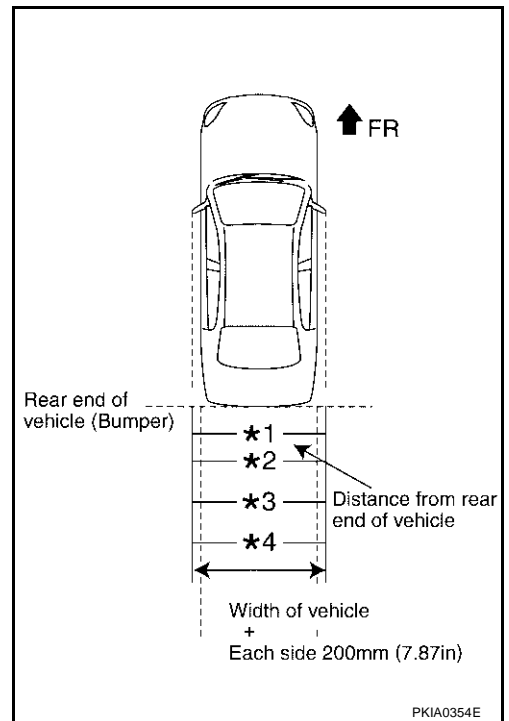

3. Using the joy stick, select the pattern closest to the prepared correction line among the 6 guideline patterns, then press "ENTER" button.

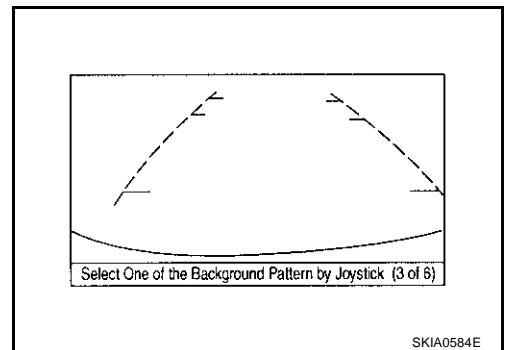

REAR VIEW MONITOR

- Carefully adjust the center of the background vertically and horizontally in the range of 8 - 8. Align it with the prepared line, and press the "ENTER" button.
- The adjustment is completed.

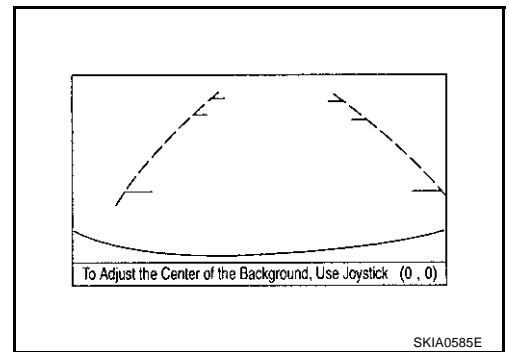

REAR VIEW MONITOR

EKS0012N

Power Supply and Ground Circuit Check

1. CHECK THE FUSES.

- Check 15A fuse [No. 52, located in fuse, fusible link and relay block (J/B)].
- Check 10A fuse [No. 21, located in fuse block (J/B) No. 1].

OK or NG

OK >> GO TO 2.

NG >> If fuse is blown, be sure to eliminate cause of malfunction before installing new fuse. Refer to [PG-2, "POWER SUPPLY ROUTING"](#).

2. POWER SUPPLY CIRCUIT CHECK

1. Disconnect rear view camera control unit connector.
2. Check voltage between rear view camera control unit and ground.

Terminals		(-)	OFF	ACC	ON
(+) Terminal (Wire color)					
Connector	Terminal				
B236	2 (SB)	Ground	Battery voltage	Battery voltage	Battery voltage
B236	4 (OR)	Ground	0V	Battery voltage	Battery voltage

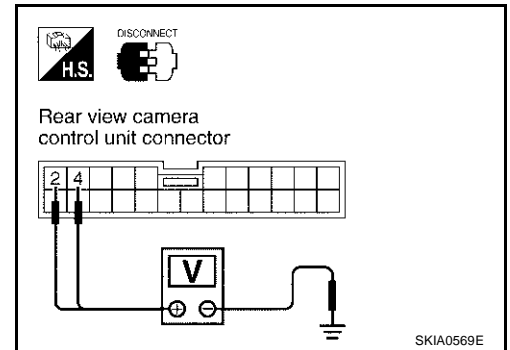

OK or NG

OK >> GO TO 3.

NG >> Check harness for open or short between rear view camera control unit and fuse.

3. REARVIEW CAMERA CONTROL UNIT GROUND CIRCUIT CHECK

1. Turn ignition switch OFF.
2. Check continuity between rear view camera control unit harness connector B236 terminal 1 (B) and ground.

Continuity should exist.

OK or NG

OK >> GO TO 4.

NG >> Repair harness or connector.

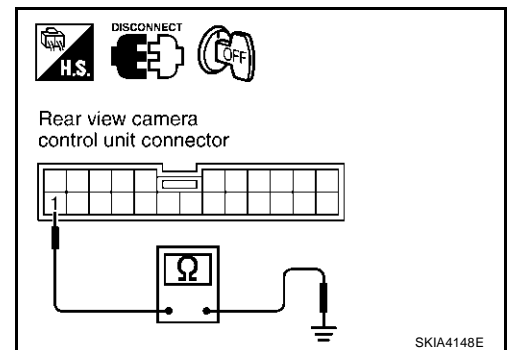

4. REARVIEW CAMERA GROUND CIRCUIT CHECK

1. Disconnect rear view camera connector.
2. Continuity between rear view camera harness connector B50 terminal 2 (B) and ground.

Continuity should exist.

OK or NG

OK >> Inspection end.

NG >> Repair harness or connector.

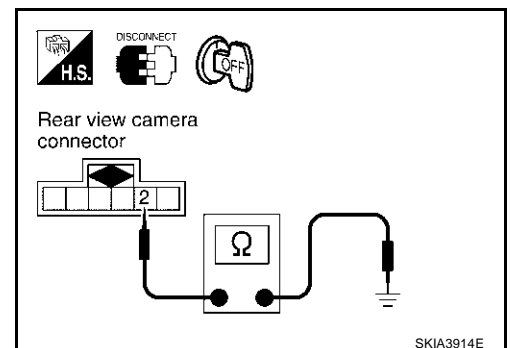

REAR VIEW MONITOR

EKS00120

Rear View Is Not Displayed With The A/T Selector Lever In R-position.

1. BACK-UP LAMP INSPECTION

1. Turn ignition switch ON.
2. Shift A/T selector lever to R-position.

Dose back-up lamp illuminate?

YES >> GO TO 2.

NO >> Check back-up lamp system. Refer to [LT-71, "BACK-UP LAMP"](#) in LT section.

2. CHECK REVERSE POSITION INPUT SIGNAL

1. Turn ignition switch OFF.
2. Disconnect rear view camera control unit connector.
3. Turn ignition switch ON.
4. Shift the A/T selector lever to R-position.
5. Check voltage between rear view camera control unit harness connector B236 terminal 10 (R/B) and ground.

Battery voltage should exist.

OK or NG

OK >> GO TO 3.

NG >> Check harness for open or short between rear view camera control unit and back-up lamp relay.

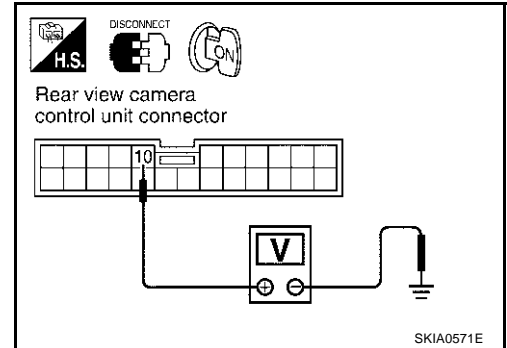

3. CHECK REARVIEW CAMERA OPEN CIRCUIT

1. Turn ignition switch OFF.
2. Disconnect rear view camera control unit connector and rear view camera connector.
3. Check the following.
 - Continuity between rear view camera harness connector B50 terminal 1 (R/G) and rear view camera control unit harness connector B236 terminal 6 (R/G).

Continuity should exist.

- Continuity between rear view camera harness connector B50 terminal 3 (W) and rear view camera control unit harness connector B236 terminal 18 (Y).

Continuity should exist.

- Continuity between rear view camera harness connector B50 terminal 4 (B) and rear view camera control unit harness connector B236 terminal 16 (BR).

Continuity should exist.

OK or NG

OK >> GO TO 4.

NG >> Repair harness or connector.

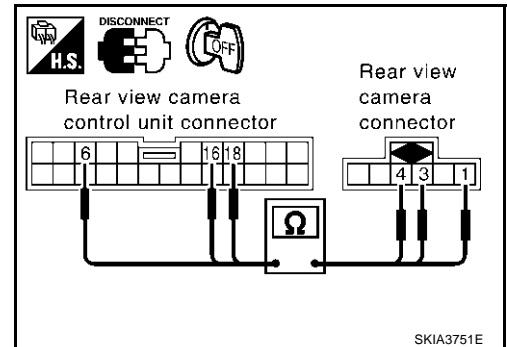

REAR VIEW MONITOR

4. CHECK REARVIEW CAMERA SHORT CIRCUIT

Check the following.

- Continuity between rear view camera control unit harness connector B236 terminal 6 (R/G) and ground.

Continuity should not exist.

- Continuity between rear view camera control unit harness connector B236 terminal 16 (BR) and ground.

Continuity should not exist.

- Continuity between rear view camera control unit harness connector B236 terminal 18 (Y) and ground.

Continuity should not exist.

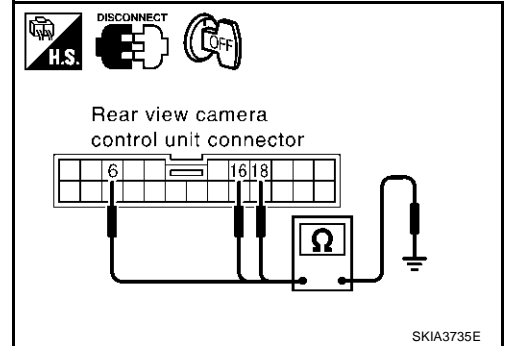

OK or NG

OK >> GO TO 5.

NG >> Repair harness on connector.

5. CHECK POWER SUPPLY AND GROUND CIRCUIT

Check power supply and ground circuit. Refer to [DI-177, "Power Supply and Ground Circuit Check"](#).

OK or NG

OK >> GO TO 6.

NG >> Repair or replace power supply and ground circuit.

6. CHECK REARVIEW CAMERA CONTROL UNIT OUTPUT SIGNAL

1. Connect rear view camera control unit connector.
2. Turn ignition switch ON.
3. Shift A/T selector lever to R-position.
4. Check voltage between rear view camera control unit harness connector B236 terminal 6 (R/G) and ground.

Approx. 9V

OK or NG

OK >> GO TO 7.

NG >> Replace rear view camera control unit.

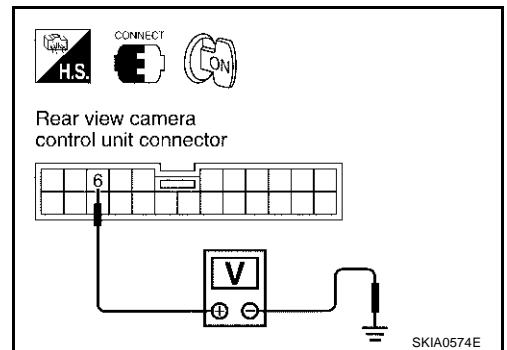

7. CHECK REARVIEW CAMERA SIGNAL

1. Connect the rear view camera connector.
2. Check voltage between rear view camera control unit harness connector B236 terminal 18 (Y) and ground.

18 (Y) - Ground : Refer to [DI-173, "Terminals and Reference Value for Rear View Camera Control Unit"](#).

OK or NG

OK >> Replace rear view camera control unit.

NG >> Replace rear view camera.

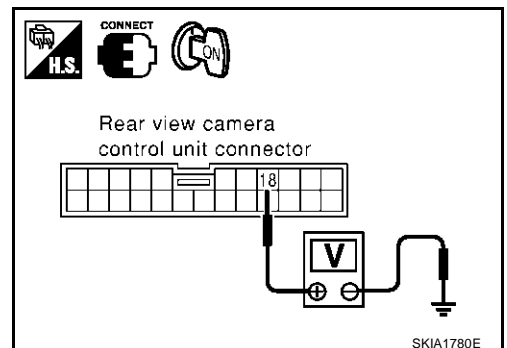

REAR VIEW MONITOR

The Backlight Correction Does Not Work When The ENTER Switch Is Pressed.

EKS0012P

1. CHECK MULTIFUNCTION SWITCH

Perform multifunction switch self-diagnosis, refer to [DI-118, "Multifunction Switch Self-Diagnosis Function"](#).

OK or NG

- OK >> GO TO 2.
- NG >> Replace multifunction switch.

2. CHECK REARVIEW CAMERA IRIS SIGNAL

1. Disconnect rear view camera connector.
2. Turn ignition switch ON.
3. Shift the A/T selector lever to R-position.
4. Check voltage between rear view camera harness connector B50 terminal 5 (L) and ground.

Approx. 9V

OK or NG

- OK >> Replace rear view camera.
- NG >> GO TO 3.

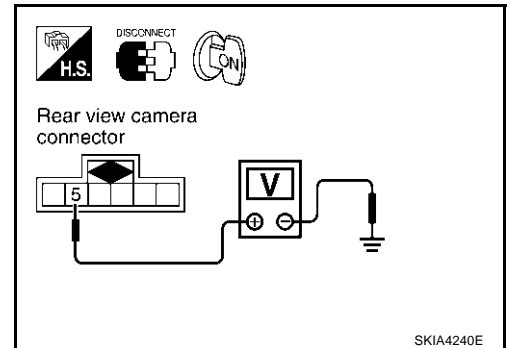

3. CHECK REARVIEW CAMERA IRIS SIGNAL CIRCUIT

1. Turn ignition switch OFF.
2. Disconnect rear view camera control unit connector.
3. Check continuity between rear view camera control unit harness connector B236 terminal 8 (L) and rear view camera harness connector B50 terminal 5 (L).

Continuity should exist.

OK or NG

- OK >> Replace rear view camera control unit.
- NG >> Repair harness or connector.

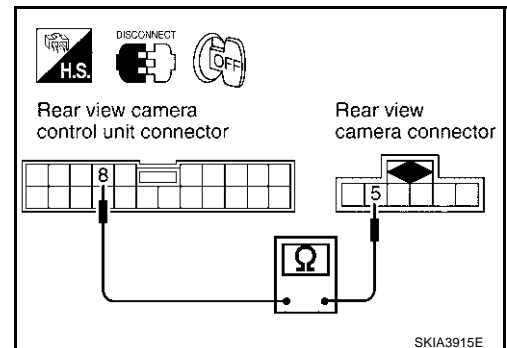

REAR VIEW MONITOR

EKS0012Q

The Rear View Image Is Distorted.

1. CHECK SYNCHRO SIGNAL OPEN OR SHORT CIRCUIT

1. Turn ignition switch OFF.
2. Disconnect rear view camera control unit connector and display connector.
3. Check the following.
 - Continuity between rear view camera control unit harness connector B236 terminal 22 (PU) and display harness connector M82 terminal 10 (PU).

Continuity should exist.

- Continuity between display harness connector M82 terminal 10 (PU) and ground.

Continuity should not exist.

OK or NG

- OK >> GO TO 2.
NG >> Repair harness or connector.

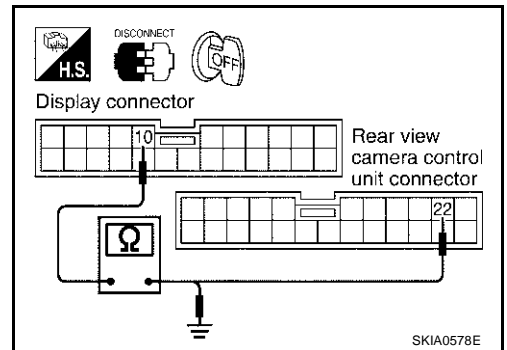

2. CHECK COMPO SIGNAL GROUND CIRCUIT

Check continuity between rear view camera control unit B236 harness connector terminal 23 and display harness connector M82 terminal 11.

Continuity should exist.

OK or NG

- OK >> GO TO 3.
NG >> Repair harness or connector.

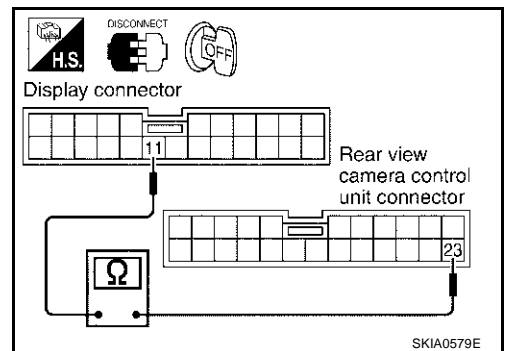

3. CHECK REARVIEW CONTROL UNIT SYNCHRO SIGNAL

1. Connect rear view camera control unit connector and display connector.
2. Turn ignition switch ON.
3. Check signal between rear view camera control unit harness connector B236 terminal 22 (PU) and ground.

22 (PU) - Ground : Refer to [DI-173, "Terminals and Reference Value for Rear View Camera Control Unit"](#) .

OK or NG

- OK >> Replace rear view camera control unit.
NG >> Replace display.

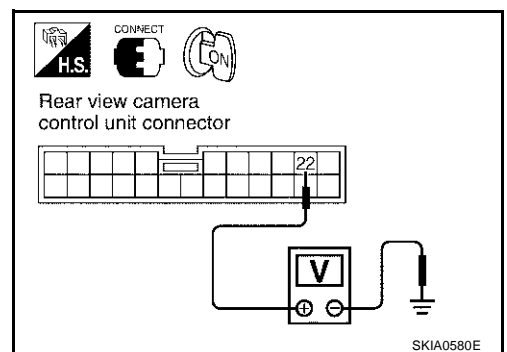

A
B
C
D
E
F
G
H
I
J
DI
L
M

REAR VIEW MONITOR

Removal and Installation of Rear View Camera Control Unit

EKS0012R

REMOVAL

1. Remove the trunk trim. Refer to [EI-52, "TRUNK ROOM TRIM & TRUNK LID FINISHER"](#) .
2. Remove the rear parcel shelf finisher. Refer to [EI-39, "REAR PARCEL SHELF FINISHER"](#) .
3. Remove the bolts (2), and remove rear view camera control unit.

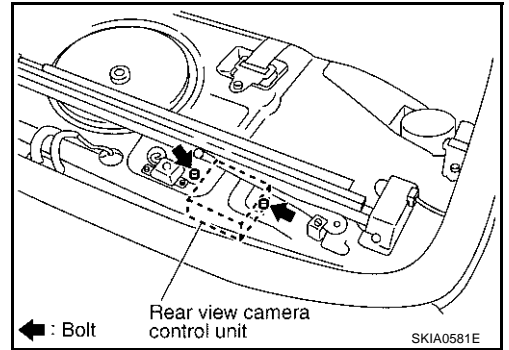

INSTALLATION

Install in the reverse order of removal.

Removal and Installation of Rear View Camera

REMOVAL

1. Remove the license plate finisher. Refer to [EI-29, "LICENSE LAMP FINISHER"](#) .
2. Remove the screws (2), and remove the rear view monitor camera.
3. Remove the screws (2), and remove the rear view monitor camera cover.

EKS0012W

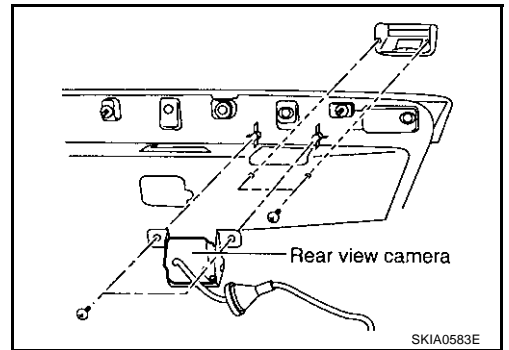

INSTALLATION

Install in the reverse order of removal.

VOICE ACTIVATED CONTROL SYSTEM

VOICE ACTIVATED CONTROL SYSTEM

PFP:28337

System Description OUTLINE

EKS0017C

- The VACS (Voice-Activated Control System) provides a safe and convenient way of controlling vehicle systems such as the audio, auto A/C and navigation (if so equipped). The system is controlled by the PTT (Push to talk) button. Voice commands are picked up by a microphone. When giving a command, voice feedback will be heard through the speaker, and messages will be shown on the display. Voice feedback can be turned off. Personal directories of nametags for radio station presets can be created, and spoken command help is provided.
- Refer to Owner's Manual for voice activated control system operating instructions.

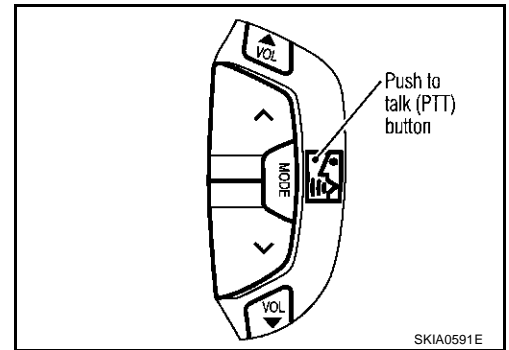

Power is supplied at all times.

- through 15A fuse (No. 52, located in fuse, fusible link and relay block).
- to Voice Activated Control Module terminal 13.

With the ignition switch in the ACC or ON position, power is supplied.

- through 10A fuse [No. 21, located in the fuse block (J/B) No. 1].
- to Voice Activated Control Module terminal 20.

Ground is also supplied

- to Voice Activated Control Module terminal 14
- through grounds B57 and B17.

VOICE ACTIVATED CONTROL FUNCTION

When PTT switch pushed ON, signal is sent

- from steering switch terminal 2
- to multifunction switch terminal 7, then
- via multifunction switch, display and AV and NAVI control unit (with navigation system) or AV control unit (without navigation system) with AV communication line
- to voice activated control module terminals 35 and 36.

Voice activated control module displays "LISTENING" on screen when PTT switch is ON.

When any voice is input into microphone, voice signal is sent

- from microphone terminals 4 and 5
- to voice activated control module terminals 33 and 34.

When voice activated control module identifies voice signal as a command, it sends the signal

- from voice activated control module terminals 35 and 36
- to AV and NAVI control unit (with navigation system) or AV control unit (without navigation system) terminals 49 and 50 with AV communication line.

Then AV and NAVI control unit (with navigation system) or AV control unit (without navigation system) sends operational signal

- to display and audio unit and performs the voice command.

While voice activated control system is in operation, voice activated control module sends voice signal

- from voice activated control module terminals 25 and 26
- to BOSE speaker amp. terminals 26 and 42, and guides various operations.

Also at the same time voice activated control module sends mute signal

- from voice activated control module terminal 27
- to audio unit terminal 9

in order to prevent any noise input into microphone.

VOICE ACTIVATED CONTROL SYSTEM

AV COMMUNICATION LINE

Voice Activated Control Module is connected to the following units through AV Communication Line. Each unit transmits/receives data with AV communication line.

- AV and NAVI control unit (with navigation system)
- AV control unit (without navigation system)
- Display
- Audio unit
- Multifunction switch

VOICE ACTIVATED CONTROL SYSTEM

Schematic

EKS001BR

- (NV) : With NAVI
- (ON) : Without NAVI
- *1 44 : (NV)
- *2 45 : (ON)
- *3 43 : (NV)
- *4 47 : (NV)
- *5 48 : (NV)
- *6 46 : (ON)
- 47 : (ON)
- 48 : (ON)
- 49 : (ON)
- 50 : (ON)
- 51 : (ON)

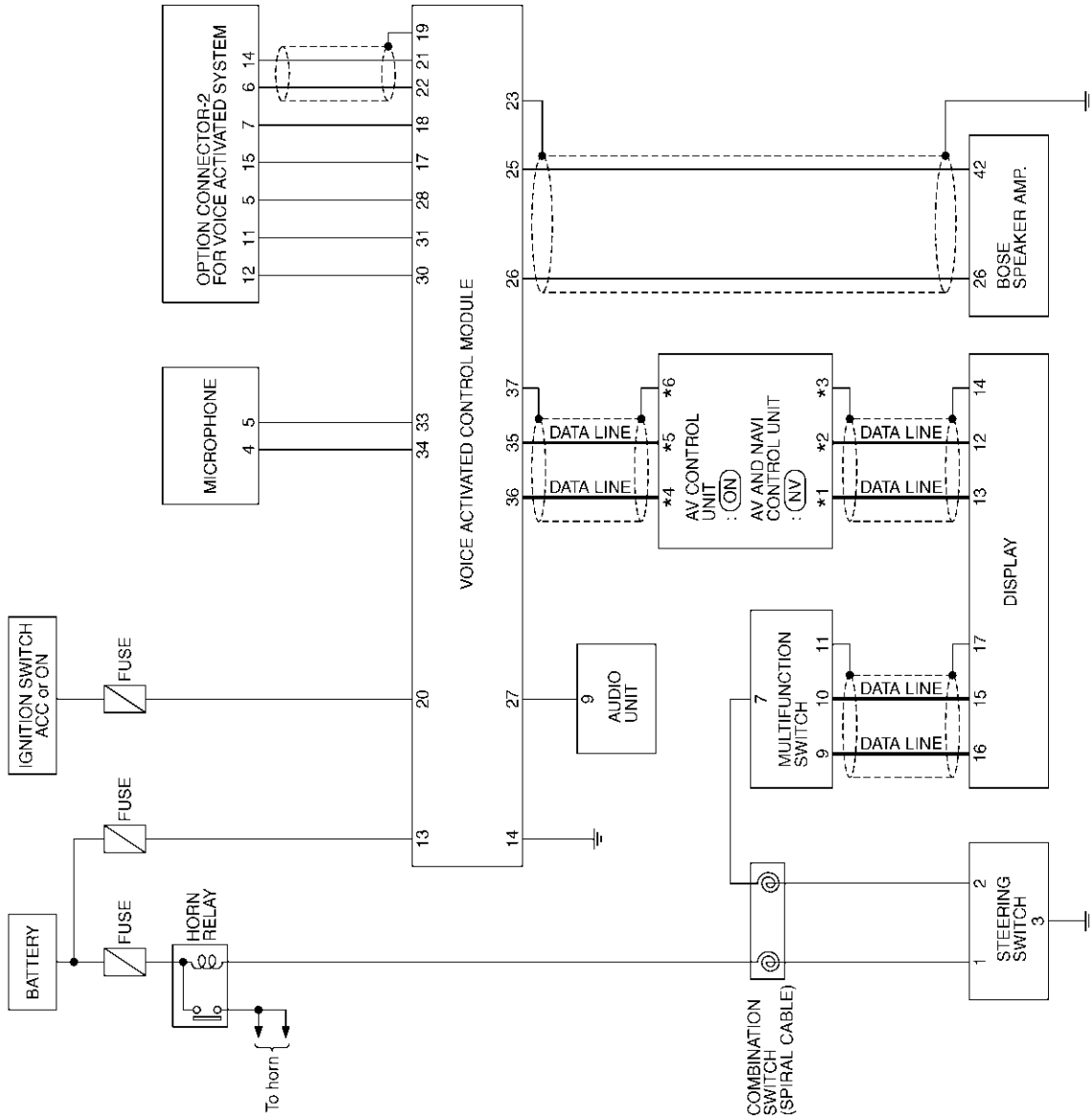

A
B
C
D
E
F
G
H
I
J
DI
L
M

TKWM0287E

VOICE ACTIVATED CONTROL SYSTEM

Wiring Diagram — VOICE —

EKS0017D

DI-VOICE-01

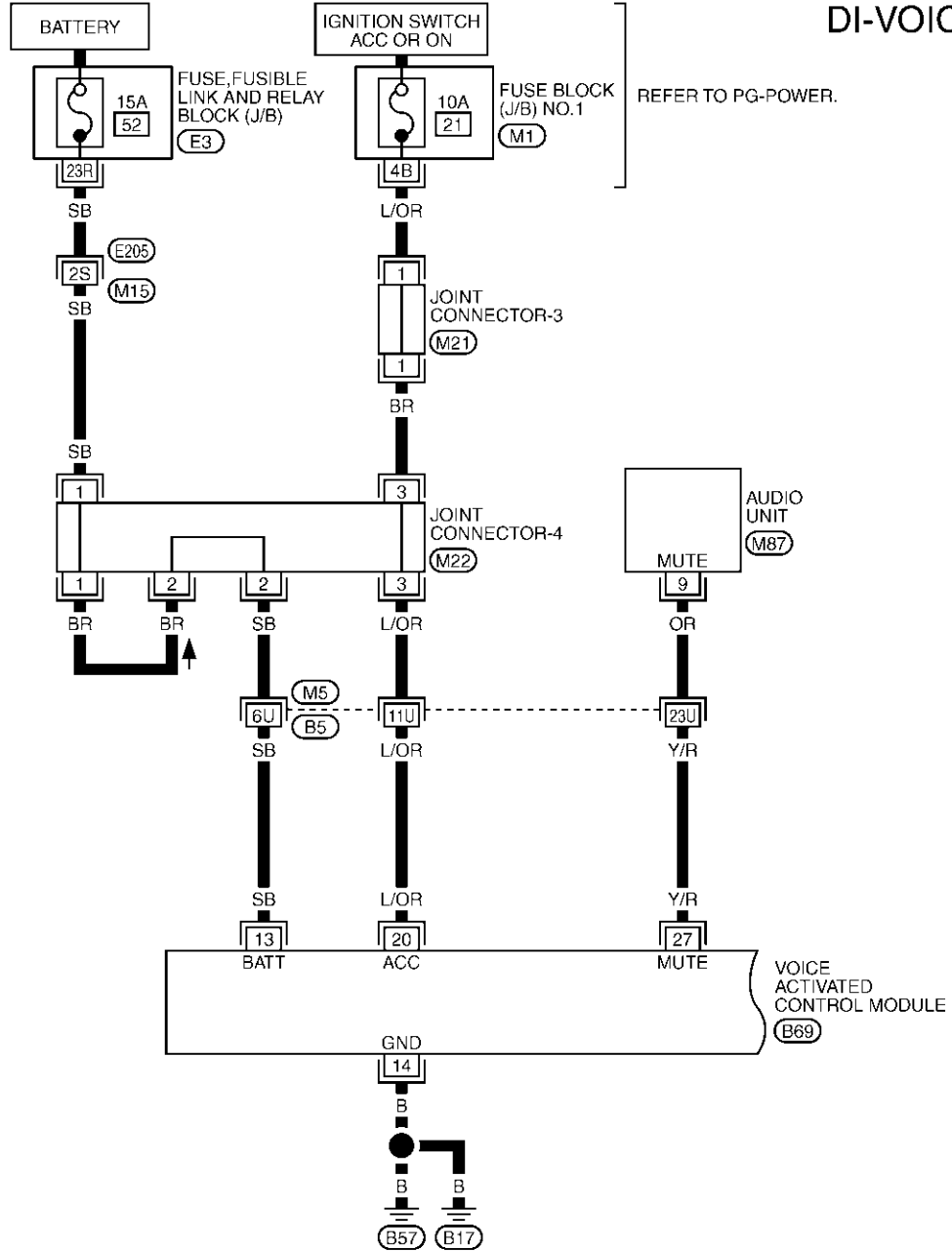

(M21)
GY



(M22)
L

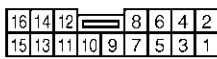

(M87)
W

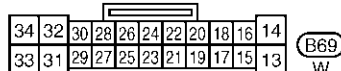

(B69)
W

REFER TO THE FOLLOWING.

(M5), (E205) -SUPER MULTIPLE JUNCTION (SMJ)

(M1) -FUSE BLOCK-JUNCTION BOX (J/B) NO.1

(E3) -FUSE, FUSIBLE LINK AND RELAY BLOCK (J/B)

TKWM0288E

VOICE ACTIVATED CONTROL SYSTEM

DI-VOICE-02

A
B
C
D
E
F
G
H
I
J
DI
L
M

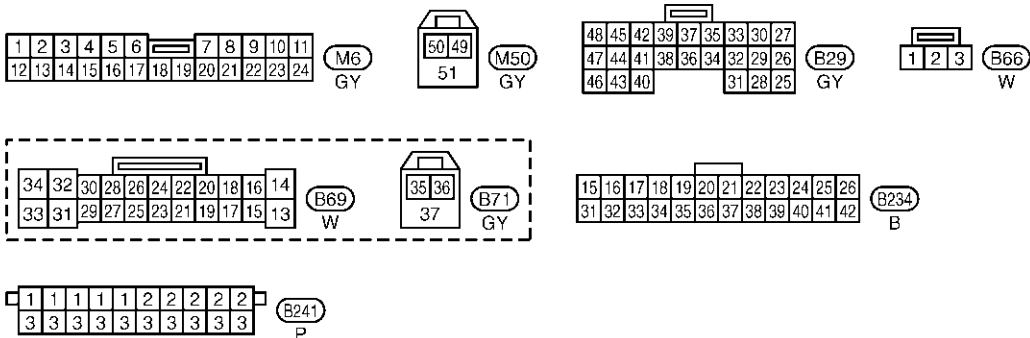
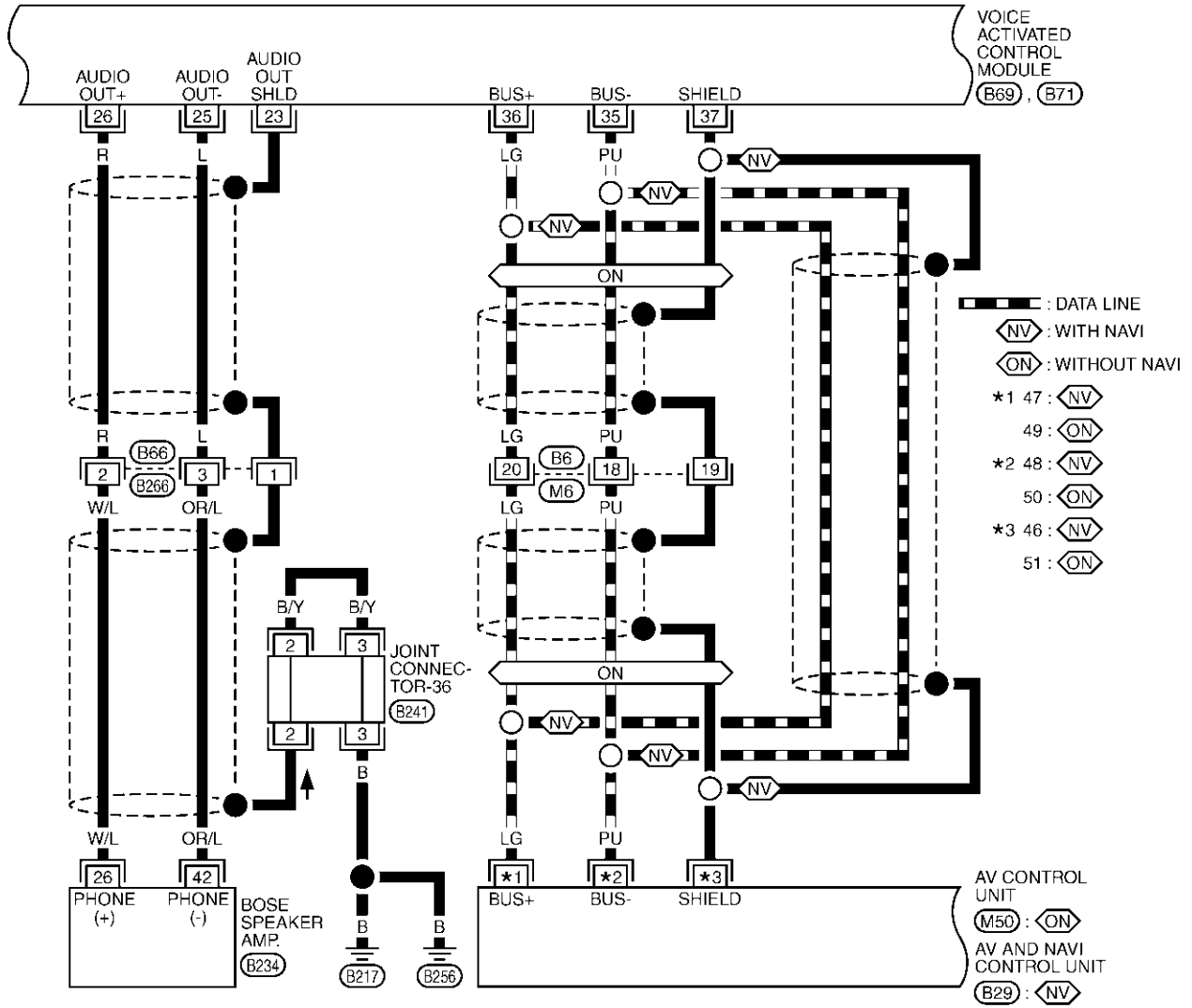

TKWM0289E

VOICE ACTIVATED CONTROL SYSTEM

DI-VOICE-03

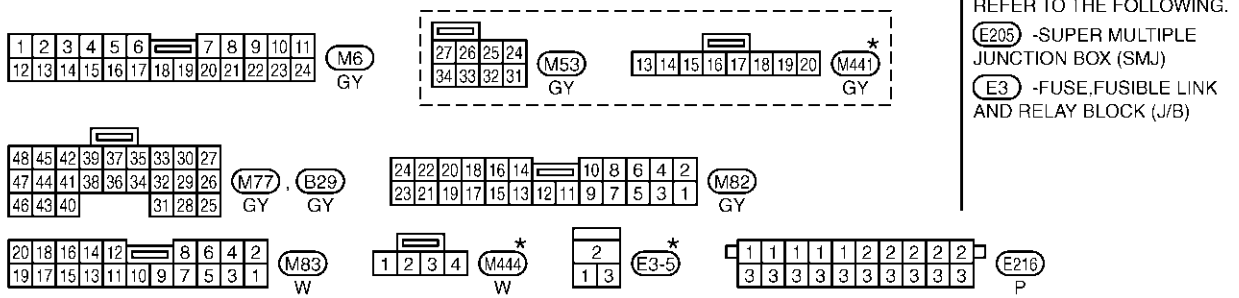
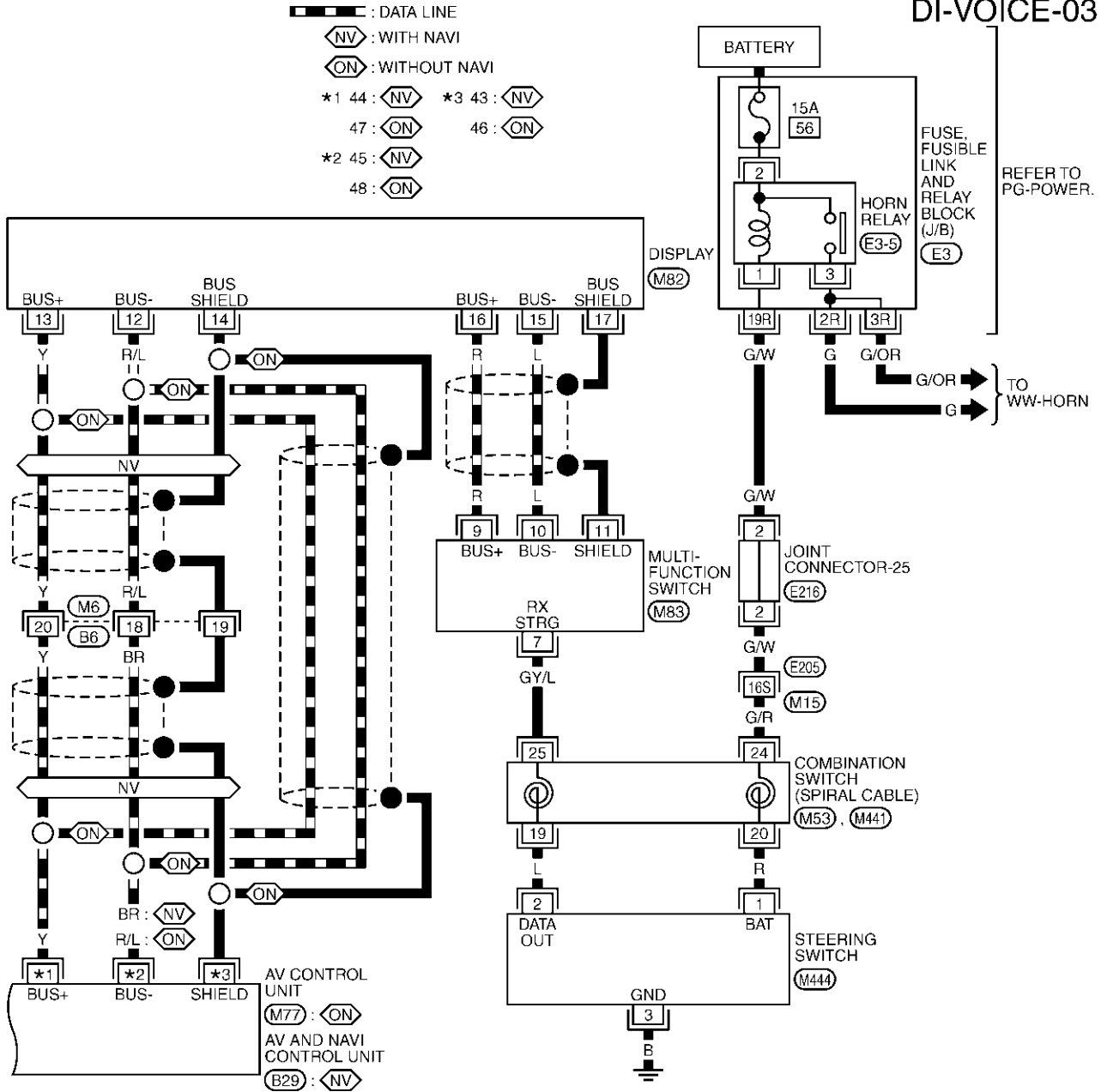

TKWM0290E

VOICE ACTIVATED CONTROL SYSTEM

DI-VOICE-04

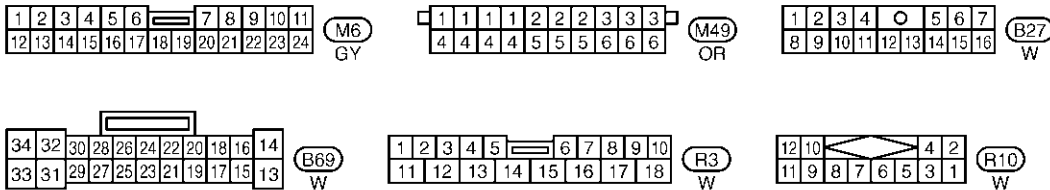
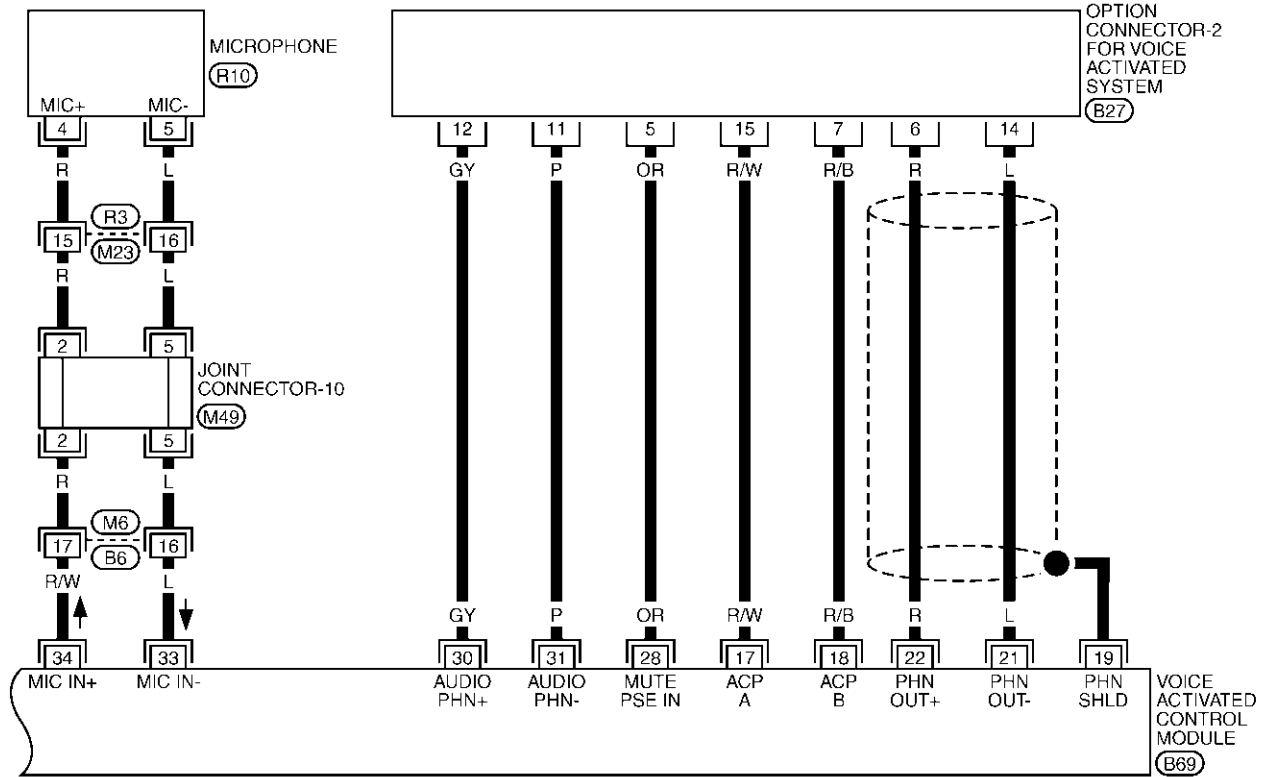

TKWM0291E

VOICE ACTIVATED CONTROL SYSTEM

Terminals and Reference Values for Voice Activated Control Module

EKS0017E

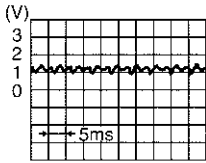
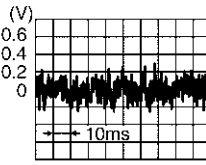
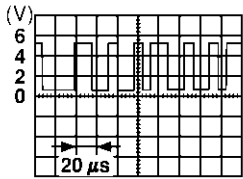
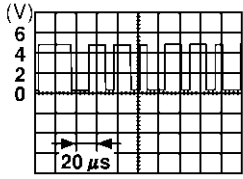
Terminals				Item	Condition	Reference value (V)
(+)		(-)				
Terminal No.	Wire color	Terminal No.	Wire color			
13	SB	Ground	-	Power source (BAT)	-	Battery voltage
14	B	Ground	-	Ground	-	Approx. 0
20	L/OR	Ground	-	Ignition switch (ACC)	ACC	Battery voltage
23	-	-	-	Audio shield ground	-	-
25	L	23	-	Audio output (-)	Voice guide operates.	 <p style="text-align: right; font-size: small;">PKIA0355E</p>
26	R	23	-	Audio output (+)		
27	Y/R	Ground	-	Mute	PTT switch (not operate → operate)	Approx. 5 → Approx. 0
34	R/W	33	L	Mic input	Voice mic test operates.	 <p style="text-align: right; font-size: small;">PKIA0356E</p>
35	PU	37	-	Communication signal (-)	-	 <p style="text-align: right; font-size: small;">SKIA0176E</p>
36	LG	37	-	Communication signal (+)	-	 <p style="text-align: right; font-size: small;">SKIA0175E</p>
37	-	-	-	Shield ground	-	-

VOICE ACTIVATED CONTROL SYSTEM

Component Parts and Harness Connector Location

EKS0017F

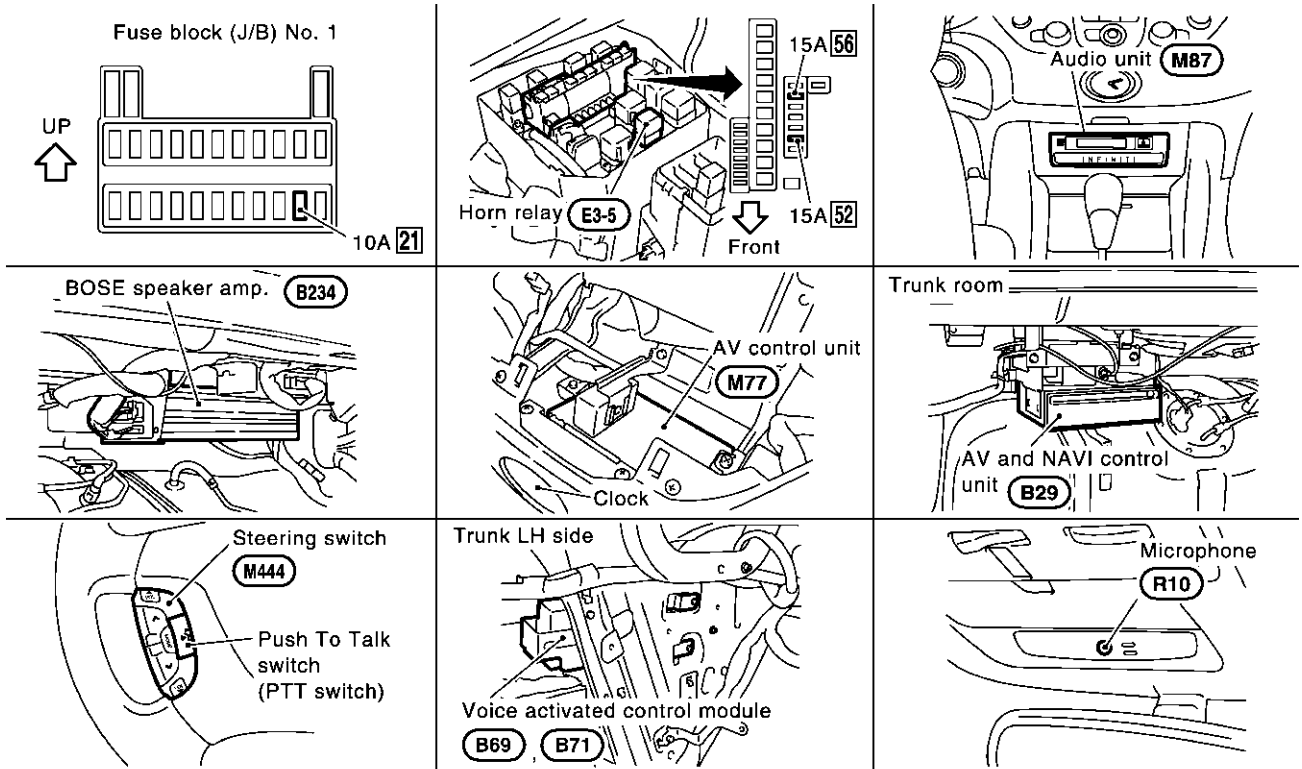

A
B
C
D
E
F
G
H
I
J
DI
L
M

SKIA3917E

VOICE ACTIVATED CONTROL SYSTEM

Trouble Diagnoses THIS CONDITION IS NOT MALFUNCTION

EKS0017G

Example of Basic Operational Errors

The system should respond correctly to all voice commands. Follow the solutions given in this guide for the appropriate error when any of the following symptom is encountered.

Where the solutions are listed by number, try each solution in turn, starting with number one, until the symptom is resolved.

Symptom	Remedy
Displays "COMMAND NOT RECOGNIZED" or the system does not interpret the command correctly.	<ol style="list-style-type: none"> 1. Ensure that the command is valid, see Command list (Refer to Owner's Manual). 2. Ensure that the command is given after the tone while "LISTENING" is displayed. 3. Speak clearly without pausing between words and at a level appropriate to the ambient noise level. 4. Ensure that the ambient noise level is not excessive, for example, windows open or defrost on. <p>NOTE: If it is too noisy to use the microphone, it is likely that voice commands will not be recognized.</p> <ol style="list-style-type: none"> 5. If optional words of the command have been omitted, then the command should be tried with these in place. 6. If a number of commands have been given in rapid succession resulting in the message "COMMAND NOT RECOGNIZED" to be displayed, then allow the system to recover (approximately one minute) before trying the command again. 7. If the system consistently does not recognize commands, the voice training procedure should be carried out to improve the recognition response for the speaker.
Displays "NO SPEECH DETECTED".	<ol style="list-style-type: none"> 1. Ensure that the command is given after the tone while "LISTENING" is displayed. 2. Ensure that the command is given within a maximum of five seconds from the end of the tone. <p>NOTE: Be sure you know what to say before pressing the Voice button.</p>
Displays "NAMETAG NOT UNIQUE".	<ol style="list-style-type: none"> 1. This response will be received when storing a nametag if the nametag being given has already been stored. This can be confirmed by giving the Radio Directory command. 2. If this response is received and the nametag has not been used already, then it is too similar to an existing nametag or voice grammar and an alternative should be used.
The system consistently selects the wrong nametag.	<ol style="list-style-type: none"> 1. Ensure that the nametag requested matches what was originally stored. This can be confirmed by giving the Radio Directory command. 2. Delete one of the nametags being confused and replace it with a different nametag.

Self-Diagnosis Function DESCRIPTION

EKS001AT

- Diagnosis function consists of the self-diagnosis mode, and the "CONFIRMATION/ADJUSTMENT" mode.
- Self-diagnosis mode checks for connection between AV and NAVI control unit (with navigation system) or AV control unit (without navigation system) and voice activated control module and analyzes each unit, then displays the results.
- "CONFIRMATION/ADJUSTMENT" function analyzes each microphone.

DIAGNOSIS ITEM

Mode	Description
Self-diagnosis	<ul style="list-style-type: none"> ● Checks for the connections between AV and NAVI control unit or AV control unit and voice activated control module. ● Performs the unit diagnosis of voice activated control module.
CONFIRMATION/ ADJUSTMENT	Voice Mic. Test <ul style="list-style-type: none"> ● Checks microphone.

Self-Diagnosis Mode OPERATION PROCEDURE

EKS001AU

- To start the self-diagnosis mode and to check the diagnosis result, refer to [DI-109, "Self-Diagnosis Mode"](#) (with navigation system), or [DI-109, "Self-Diagnosis Mode"](#) (without navigation system).

VOICE ACTIVATED CONTROL SYSTEM

EKS001AV

Confirmation/Adjustment Mode OPERATION PROCEDURE

1. Start the engine.
2. Turn the audio system off.
3. While pressing the "INFO" switch, turn the volume control dial clockwise or counterclockwise for 30 clicks or more.

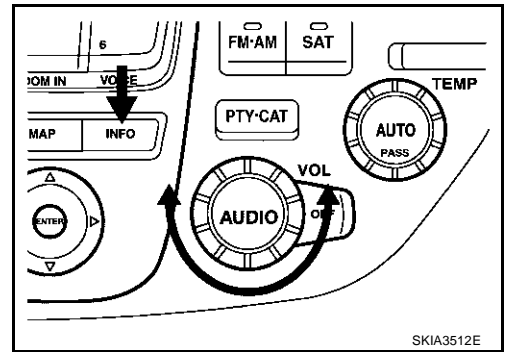

4. The initial trouble diagnosis screen will be shown, and items "SELF-DIAGNOSIS" and "CONFIRMATION/ADJUSTMENT" will become selective.
5. When "CONFIRMATION/ADJUSTMENT" is selected on the trouble diagnosis screen, the operation will enter the CONFIRMATION/ADJUSTMENT mode. In this mode, check and adjustment of each item will become possible.

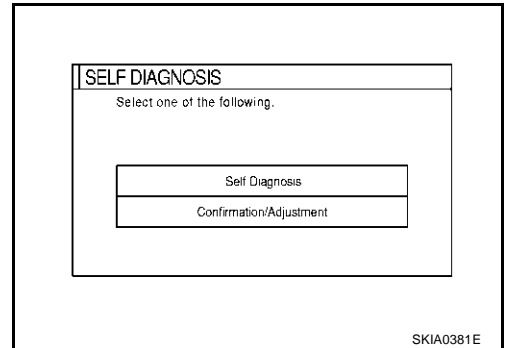

6. When "Voice Mic. Test" is selected with joystick, icon indicator turns on (green) and voice input into microphone is sent out through speakers.

NOTE:

Voice from speakers may sound echoic.

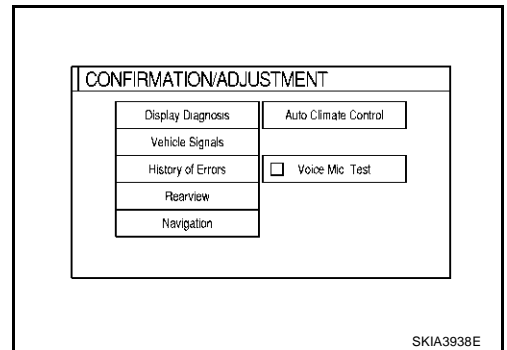

A
B
C
D
E
F
G
H
I
J
DI
L
M

VOICE ACTIVATED CONTROL SYSTEM

EKS001AW

Power Supply and Ground Circuit Inspection

1. CHECK FUSES

Check that any of the following fuses for voice activated control module is blown.

Unit	Power source	Fuse No.
Voice Activated Control Module	Battery	52
	Ignition switch ACC or ON	21

OK or NG

OK >> GO TO 2.

NG >> If fuse is blown, be sure to eliminate cause of malfunction before installing new fuse. Refer to [PG-2, "POWER SUPPLY ROUTING"](#).

2. CHECK POWER SUPPLY CIRCUIT

Check voltage between voice activated control module harness connector B69 terminal 13 (SB), 20 (L/OR) and ground.

Terminals		Ignition switch position			
(+)		(-)	OFF	ACC	ON
Connector	Terminal (Wire color)				
B69	13 (SB)	Ground	Battery voltage	Battery voltage	Battery voltage
B69	20 (L/OR)	Ground	0V	Battery voltage	Battery voltage

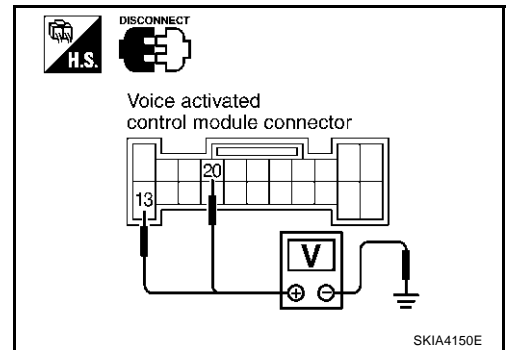

OK or NG

OK >> GO TO 3.

NG >> Check harness between voice activated control module and fuse.

3. CHECK GROUND CIRCUIT

Check continuity between voice activated control module harness connector B69 terminal 14 (B) and ground.

Continuity should exist.

OK or NG

OK >> Inspection end.

NG >> Repair harness or connector.

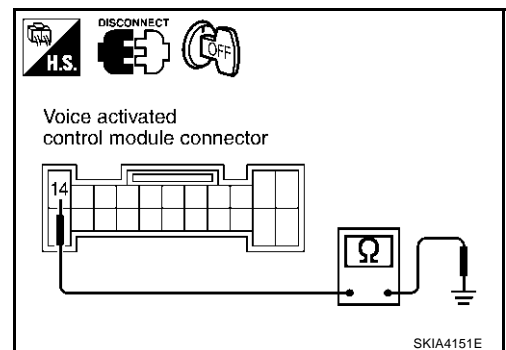

VOICE ACTIVATED CONTROL SYSTEM

Voice Command Not Identified (With Voice Activated Control System in Operation)

EKS001B0

1. CHECK MICROPHONE OPERATION

1. Select "Voice Mic. Test" of "CONFIRMATION/ADJUSTMENT" mode. Refer to [DI-193, "Confirmation/Adjustment Mode"](#).
2. Speak to microphone, and check if the sound is heard from (right) instrument speaker.

OK or NG

- OK >> Replace voice activated control module.
- NG >> GO TO 2.

2. CHECK MICROPHONE CIRCUIT

1. Disconnect voice activated control module connector and microphone connector.
 2. Check the following.
- Continuity between voice activated control module harness connector B69 terminal 33 (L) and microphone connector R10 terminal 5 (L).

Continuity should exist.

- Continuity between voice activated control module harness connector B69 terminal 34 (R/W) and microphone harness connector R10 terminal 4 (R).

Continuity should exist.

- Continuity between voice activated control module harness connector B69 terminal 33 (L), 34 (R/W) and ground.

Continuity should not exist.

OK or NG

- OK >> GO TO 3.
- NG >> Repair harness or connector.

3. CHECK MICROPHONE SIGNAL

1. Connect voice activated control module connector and microphone connector.
2. Turn ignition switch ON.
3. Speak to microphone and check signal between voice activated control module connector B69 terminal 34 (R/W) and 33 (L) with CONSULT-II or oscilloscope.

34 (R/W) - 33 (L) : Refer to [DI-190, "Terminals and Reference Values for Voice Activated Control Module"](#).

OK or NG

- OK >> Replace voice activated control module.
- NG >> Replace microphone.

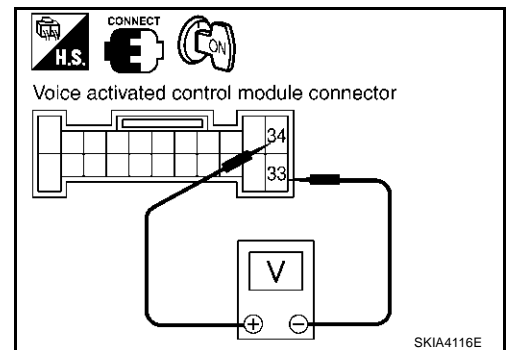
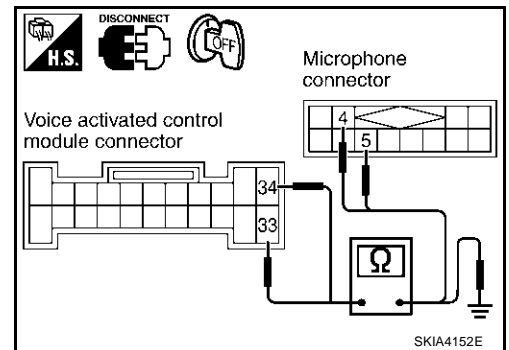

VOICE ACTIVATED CONTROL SYSTEM

EKS001AX

No Guide Sound or Beeps

1. CHECK GUIDE SOUND SETTING

Check volume setting of voice activated control system if set as 0 (zero).

OK or NG

- OK >> GO TO 2.
- NG >> Adjust volume.

2. CHECK BOSE SPEAKER AMP. CIRCUIT

1. Disconnect voice activated control module connector and BOSE speaker amp. connector.
2. Check the following.
 - Continuity between voice activated control module harness connector B69 terminal 25 (L) and BOSE speaker amp. harness connector B234 terminal 42 (OR/L)

Continuity should exist.

- Continuity between voice activated control module harness connector B69 terminal 26 (R) and BOSE speaker amp. harness connector B234 terminal 26 (W/L)

Continuity should exist.

- Continuity between voice activated control module harness connector B69 terminal 25 (L), 26 (R) and ground.

Continuity should not exist.

OK or NG

- OK >> GO TO 3.
- NG >> Repair harness or connector.

3. CHECK VOICE SIGNAL

1. Connect voice activated control module connector and BOSE speaker amp.
2. Turn ignition switch ON.
3. The Speaker Adaptation (SA) mode ON and voice guide signal sent out, check signal between voice activated control module harness connector B69 terminal 25 (L), 26 (R) and 23.

26 (R) – 23 :Refer to [DI-190, "Terminals and Reference Values for Voice Activated Control Module"](#) .
25 (L) – 23

OK or NG

- OK >> Replace BOSE speaker amp.
- NG >> Replace voice activated control module.

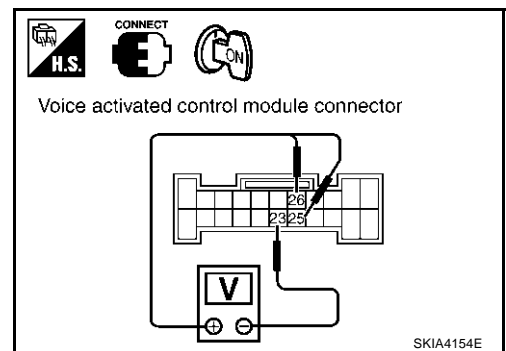
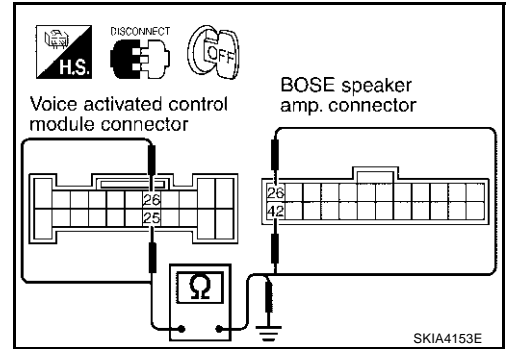

VOICE ACTIVATED CONTROL SYSTEM

Voice Activated Control System Not Starting PTT Switch Pushed ON

EKS001AY

1. CHECK PTT SWITCH OPERATION

Check PTT switch operation with self-diagnosis of multifunction switch. Refer to [DI-118, "Multifunction Switch Self-Diagnosis Function"](#) .

OK or NG

OK >> GO TO 2.

NG >> Replace steering switch.

2. CHECK MULTIFUNCTION SWITCH AND VOICE ACTIVATED CONTROL MODULE

Start self-diagnosis mode. Refer to [DI-109, "Self-Diagnosis Mode"](#) (with navigation system) or [DI-109, "Self-Diagnosis Mode"](#) (without navigation system).

Does self-diagnosis mode start?

YES >> GO TO 3.

NO >> Replace multifunction switch.

3. CHECK VOICE ACTIVATED CONTROL MODULE

Check voice activated control module with self-diagnosis mode started in previous step 2.

OK or NG

OK >> ● Replace AV and NAVI control unit (with navigation system), or
● Replace AV control unit (without navigation system).

NG >> GO TO 4.

4. CHECK POWER SUPPLY AND GROUND CIRCUIT

Check power supply and ground circuit of voice activated control module. Refer to [DI-194, "Power Supply and Ground Circuit Inspection"](#) .

OK or NG

OK >> GO TO 5.

NG >> Repair harness or connector.

A

B

C

D

E

F

G

H

I

J

DI

L

M

VOICE ACTIVATED CONTROL SYSTEM

5. CHECK AV COMMUNICATION LINE

1. Disconnect voice activated control module and AV and NAVI control unit (with navigation system) or AV control unit (without navigation system) connector.
2. Check the following.

- With navigation system

Terminals				Continuity
(+)		(-)		
Connector	Terminal (Wire color)	Connector	Terminal (Wire color)	
B71	35 (PU)	B29	48 (PU)	Yes
	36 (LG)	B29	47 (LG)	Yes
	37	B29	46	Yes
	35 (PU)	B29	46	No
	36 (LG)	B29	46	No

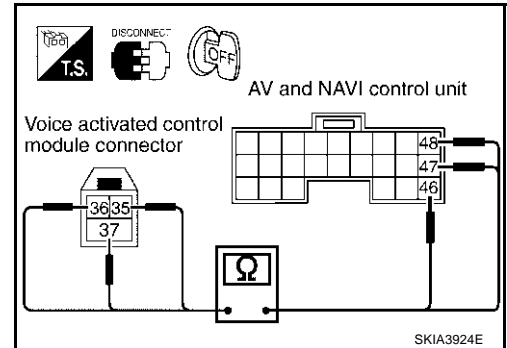

- Without navigation system

Terminals				Continuity
(+)		(-)		
Connector	Terminal (Wire color)	Connector	Terminal (Wire color)	
B71	35 (PU)	M50	50 (PU)	Yes
	36 (LG)	M50	49 (LG)	Yes
	37	M50	51	Yes
	35 (PU)	M50	51	No
	36 (LG)	M50	51	No

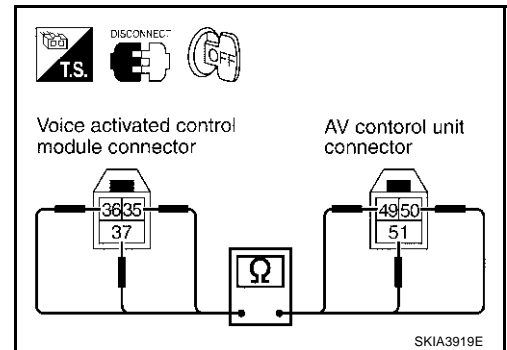

OK or NG

- OK >> Replace voice activated control module.
- NG >> Repair harness or connector.

VOICE ACTIVATED CONTROL SYSTEM

EKS001AZ

Audio Not Muted with PTT Switch Pushed ON

1. CHECK AUDIO UNIT CIRCUIT

1. Disconnect voice activated control module connector and Audio unit connector.
2. Check the following.
 - Continuity between voice activated control module harness connector B69 terminal 27 (Y/R) and Audio unit harness connector M87 terminal 9 (OR).

Continuity should exist.

- Continuity between voice activated control module harness connector B69 terminal 27 (Y/R) and ground.

Continuity should not exist.

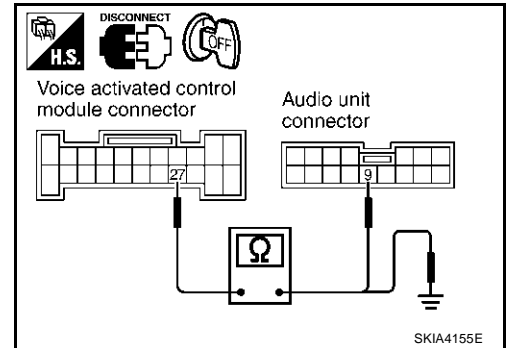

OK or NG

OK >> GO TO 2.

NG >> Repair harness or connector.

2. CHECK AUDIO UNIT MUTE SIGNAL

1. Connect voice activated control module connector and audio unit connector.
2. Turn ignition switch ON.
3. Check voltage between voice activated control module and ground.

Terminals			PTT switch condition	Voltage (V)
(+)		(-)		
Connector	Terminal (Wire color)			
B69	27 (Y/R)	Ground	ON	Approx. 0
			OFF	Approx. 5

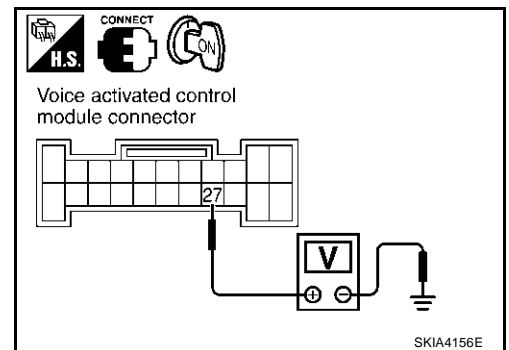

OK or NG

OK >> Replace audio Unit.

NG >> Replace voice activated control module.

A
B
C
D
E
F
G
H
I
J
DI
L
M

VOICE ACTIVATED CONTROL SYSTEM

EKS001BP

Audio Mute Not Released

1. AUDIO UNIT MUTE SIGNAL CIRCUIT

1. Disconnect voice activated control module connector and audio unit connector.
2. Check continuity between audio unit harness connector M87 terminal 9 (OR) and ground.

Continuity should not exist.

OK or NG

OK >> GO TO 2.

NG >> Repair and replace harness.

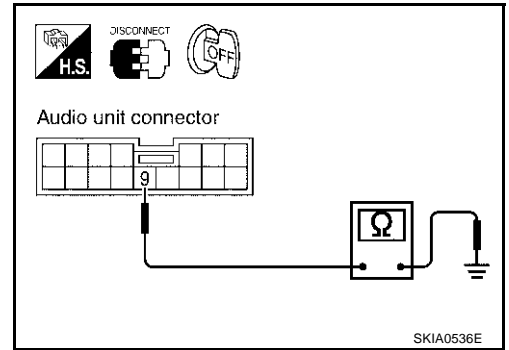

2. CHECK MUTE SIGNAL

1. Connect voice activated control module connector and audio unit connector.
2. Turn ignition switch ON.
3. Check the following.

Unit	Terminals		PTT switch condition	Voltage (V)	
	(+)				(-)
	Connector	Terminal (Wire color)			
Voice activated control module	B69	27 (Y/R)	Ground	ON	Approx.0
				OFF	Approx.5
Audio Unit	M87	9 (OR)	Ground	ON	Approx.0
				OFF	Approx.5

OK or NG

OK >> Replace audio Unit.

NG >> Replace voice activated control module.

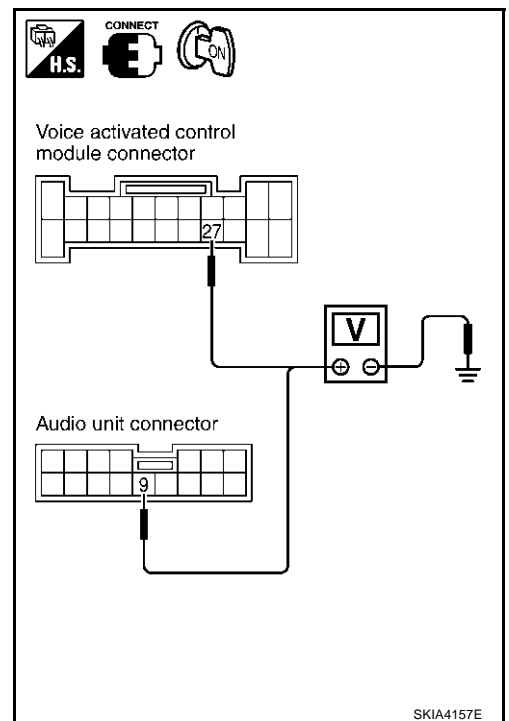

VOICE ACTIVATED CONTROL SYSTEM

Removal and Installation for Voice Activated Control Module

EKS001F3

REMOVAL

1. Remove trunk trim. Refer to [EI-52, "TRUNK ROOM TRIM & TRUNK LID FINISHER"](#) .
2. Remove voice activated control module.

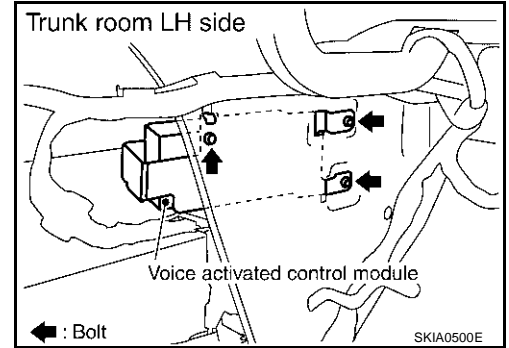

3. Remove bracket from voice activated control module.

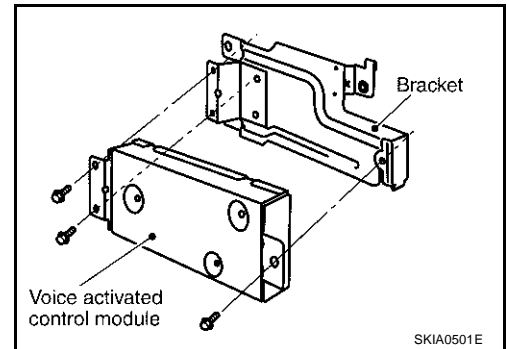

INSTALLATION

Install in the reverse order of removal.

A
B
C
D
E
F
G
H
I
J
DI
L
M

VOICE ACTIVATED CONTROL SYSTEM
