

**SECTION EI**  
**EXTERIOR & INTERIOR**

A  
B  
C  
D  
E  
F  
G  
H  
EI  
J  
K  
L  
M

**CONTENTS**

<b>PRECAUTIONS</b> .....	<b>3</b>	<b>COWL TOP</b> .....	<b>20</b>
Precautions for Supplemental Restraint System (SRS) "AIR BAG" and "SEAT BELT PRE-TENSIONER" .....	3	Removal and Installation .....	20
Precautions .....	3	REMOVAL .....	20
<b>PREPARATION</b> .....	<b>4</b>	INSTALLATION .....	20
Special Service Tools .....	4	<b>FENDER PROTECTOR</b> .....	<b>21</b>
Commercial Service Tool .....	4	Removal and Installation .....	21
<b>SQUEAK AND RATTLE TROUBLE DIAGNOSES</b> .....	<b>5</b>	REMOVAL .....	21
Work Flow .....	5	INSTALLATION .....	21
CUSTOMER INTERVIEW .....	5	<b>MUDGUARD</b> .....	<b>22</b>
DUPLICATE THE NOISE AND TEST DRIVE .....	6	Removal and Installation .....	22
CHECK RELATED SERVICE BULLETINS .....	6	REMOVAL .....	22
LOCATE THE NOISE AND IDENTIFY THE ROOT CAUSE .....	6	INSTALLATION .....	22
REPAIR THE CAUSE .....	6	<b>WINDSHIELD MOLDING</b> .....	<b>23</b>
CONFIRM THE REPAIR .....	7	Removal and Installation .....	23
Generic Squeak and Rattle Troubleshooting .....	7	REMOVAL .....	23
INSTRUMENT PANEL .....	7	INSTALLATION .....	23
CENTER CONSOLE .....	7	<b>DRIP MOLDING</b> .....	<b>25</b>
DOORS .....	7	Removal and Installation .....	25
TRUNK .....	8	REMOVAL .....	25
SUNROOF/HEADLINER .....	8	INSTALLATION .....	25
SEATS .....	8	<b>ROOF SIDE MOLDING</b> .....	<b>26</b>
UNDERHOOD .....	8	Removal and Installation .....	26
Diagnostic Worksheet .....	9	REMOVAL .....	26
<b>CLIP AND FASTENER</b> .....	<b>11</b>	INSTALLATION .....	26
Description .....	11	<b>DOOR OUTSIDE MOLDING</b> .....	<b>27</b>
<b>FRONT BUMPER</b> .....	<b>15</b>	Removal and Installation .....	27
Removal and Installation .....	15	FRONT DOOR OUTSIDE MOLDING .....	27
REMOVAL .....	15	REAR DOOR OUTSIDE MOLDING .....	27
INSTALLATION .....	16	<b>SIDE GUARD MOLDING</b> .....	<b>28</b>
<b>REAR BUMPER</b> .....	<b>17</b>	Removal and Installation .....	28
Removal and Installation .....	17	REMOVAL .....	28
REMOVAL .....	18	INSTALLATION .....	28
INSTALLATION .....	18	<b>LICENSE LAMP FINISHER</b> .....	<b>29</b>
<b>FRONT GRILLE</b> .....	<b>19</b>	Removal and Installation .....	29
Removal and Installation .....	19	REMOVAL .....	29
REMOVAL .....	19	INSTALLATION .....	29
INSTALLATION .....	19	<b>DOOR FINISHER</b> .....	<b>30</b>
		Removal and Installation .....	30
		FRONT DOOR FINISHER .....	31
		REAR DOOR FINISHER .....	32

DOOR SASH COVER .....	33	Schematic .....	42
Disassembly and Assembly .....	34	Wiring Diagram—SHADE— .....	43
FRONT DOOR TRIM (DRIVER SIDE) .....	34	Terminals and Reference Value for Rear Sunshade	
FRONT DOOR TRIM (PASSENGER SIDE) .....	35	Control Unit .....	46
REAR DOOR TRIM .....	36	<b>FLOOR TRIM .....</b>	<b>47</b>
<b>BODY SIDE TRIM .....</b>	<b>37</b>	Removal and installation .....	47
Removal and Installation .....	37	REMOVAL .....	47
CENTER PILLAR LOWER GARNISH .....	38	INSTALLATION .....	48
CENTER PILLAR UPPER GARNISH .....	38	FOOT-REST .....	48
REAR PILLAR FINISHER .....	38	<b>HEADLINING .....</b>	<b>49</b>
DASH SIDE FINISHER .....	38	Removal and Installation .....	49
<b>REAR PARCEL SHELF FINISHER .....</b>	<b>39</b>	REMOVAL .....	50
Removal and Installation .....	39	INSTALLATION .....	51
REMOVAL .....	39	<b>TRUNK ROOM TRIM &amp; TRUNK LID FINISHER .....</b>	<b>52</b>
INSTALLATION .....	40	Removal and Installation .....	52
<b>SUNSHADE .....</b>	<b>41</b>	TRUNK ROOM TRIM .....	52
Component Parts and Harness Connector Location..	41	TRUNK LID FINISHER .....	53

# PRECAUTIONS

## PRECAUTIONS

PFP:00001

### Precautions for Supplemental Restraint System (SRS) “AIR BAG” and “SEAT BELT PRE-TENSIONER”

EIS0041A

The Supplemental Restraint System such as “AIR BAG” and “SEAT BELT PRE-TENSIONER”, used along with a front seat belt, helps to reduce the risk or severity of injury to the driver and front passenger for certain types of collision. This system includes seat belt switch inputs and dual stage front air bag modules. The SRS system uses the seat belt switches to determine the front air bag deployment, and may only deploy one front air bag, depending on the severity of a collision and whether the front occupants are belted or unbelted. Information necessary to service the system safely is included in the SRS and SB section of this Service Manual.

#### **WARNING:**

- To avoid rendering the SRS inoperative, which could increase the risk of personal injury or death in the event of a collision which would result in air bag inflation, all maintenance must be performed by an authorized NISSAN/INFINITI dealer.
- Improper maintenance, including incorrect removal and installation of the SRS, can lead to personal injury caused by unintentional activation of the system. For removal of Spiral Cable and Air Bag Module, see the SRS section.
- Do not use electrical test equipment on any circuit related to the SRS unless instructed to in this Service Manual. SRS wiring harnesses can be identified by yellow and/or orange harnesses or harness connectors.

#### Precautions

EIS0015B

- Disconnect both battery cables in advance.
- Disconnect air bag system line in advance.
- Never tamper with or force air bag lid open, as this may adversely affect air bag performance.
- Be careful not to scratch pad and other parts.
- When removing or disassembling any part, be careful not to damage or deform it. Protect parts, which may get in the way with cloth.
- When removing parts with a screwdriver or other tool, protect parts by wrapping them with vinyl or tape.
- Keep removed parts protected with cloth.
- If a clip is deformed or damaged, replace it.
- If an un reusable part is removed, replace it with a new one.
- Tighten bolts and nuts firmly to the specified torque.
- After re-assembly has been completed, make sure each part functions correctly.
- Remove stains in the following way.

Water-soluble stains:

Dip a soft cloth in warm water, and then squeeze it tightly. After wiping the stain, wipe with a soft dry cloth.

Oil stain:

Dissolve a synthetic detergent in warm water (density of 2 to 3% or less), dip the cloth, then clean off the stain with the cloth. Next, dip the cloth in fresh water and squeeze it tightly. Then clean off the detergent completely. Then wipe the area with a soft dry cloth.

- Do not use any organic solvent, such as thinner or benzene.

# PREPARATION

## PREPARATION

PFP:00002

### Special Service Tools

EIS000ZF

The actual shapes of Kent-Moore tools may differ from those of special service tools illustrated here.

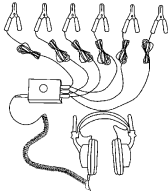
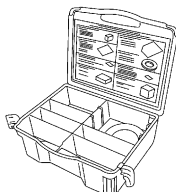
Tool number (Kent-Moore No.) Tool name	Description
(J-39570) Chassis ear   SIIA0993E	Location the noise
(J-43980) NISSAN Squeak and Rattle Kit   SIIA0994E	Repairing the cause of noise

### Commercial Service Tool

EIS000ZG

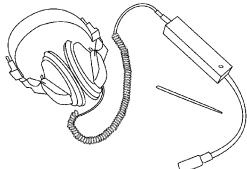
Tool name	Description
Engine ear   SIIA0995E	Location the noise

# SQUEAK AND RATTLE TROUBLE DIAGNOSES

## SQUEAK AND RATTLE TROUBLE DIAGNOSES

PPF:00000

### Work Flow

EIS000ZH

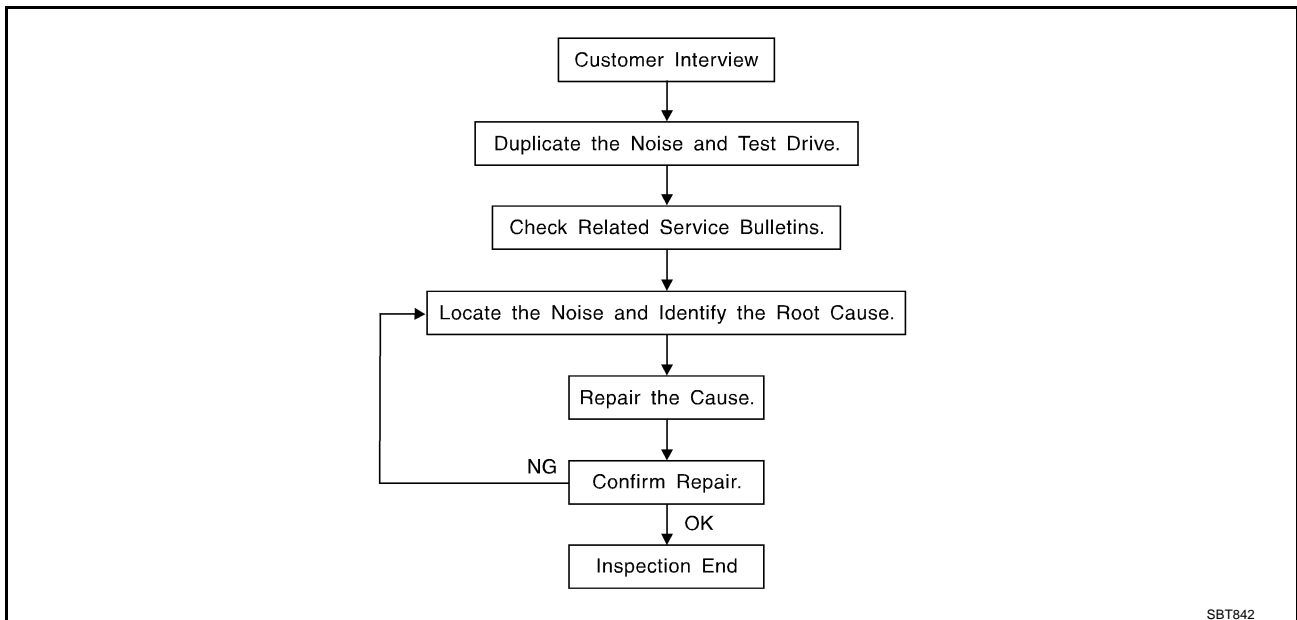

### CUSTOMER INTERVIEW

Interview the customer if possible, to determine the conditions that exist when the noise occurs. Use the Diagnostic Worksheet during the interview to document the facts and conditions when the noise occurs and any customer's comments; refer to [EI-9, "Diagnostic Worksheet"](#). This information is necessary to duplicate the conditions that exist when the noise occurs.

- The customer may not be able to provide a detailed description or the location of the noise. Attempt to obtain all the facts and conditions that exist when the noise occurs (or does not occur).
- If there is more than one noise in the vehicle, be sure to diagnose and repair the noise that the customer is concerned about. This can be accomplished by test driving the vehicle with the customer.
- After identifying the type of noise, isolate the noise in terms of its characteristics. The noise characteristics are provided so the customer, service adviser and technician are all speaking the same language when defining the noise.
- Squeak—(Like tennis shoes on a clean floor)  
Squeak characteristics include the light contact/fast movement/brought on by road conditions/hard surfaces=higher pitch noise/softer surfaces=lower pitch noises/edge to surface=chirping
- Creak—(Like walking on an old wooden floor)  
Creak characteristics include firm contact/slow movement/twisting with a rotational movement/pitch dependent on materials/often brought on by activity.
- Rattle—(Like shaking a baby rattle)  
Rattle characteristics include the fast repeated contact/vibration or similar movement/loose parts/missing clip or fastener/incorrect clearance.
- Knock—(Like a knock on a door)  
Knock characteristics include hollow sounding/sometimes repeating/often brought on by driver action.
- Tick—(Like a clock second hand)  
Tick characteristics include gentle contacting of light materials/loose components/can be caused by driver action or road conditions.
- Thump—(Heavy, muffled knock noise)  
Thump characteristics include softer knock/dead sound often brought on by activity.
- Buzz—(Like a bumble bee)  
Buzz characteristics include high frequency rattle/firm contact.
- Often the degree of acceptable noise level will vary depending upon the person. A noise that you may judge as acceptable may be very irritating to the customer.
- Weather conditions, especially humidity and temperature, may have a great effect on noise level.

# SQUEAK AND RATTLE TROUBLE DIAGNOSES

## DUPLICATE THE NOISE AND TEST DRIVE

If possible, drive the vehicle with the customer until the noise is duplicated. Note any additional information on the Diagnostic Worksheet regarding the conditions or location of the noise. This information can be used to duplicate the same conditions when you confirm the repair.

If the noise can be duplicated easily during the test drive, to help identify the source of the noise, try to duplicate the noise with the vehicle stopped by doing one or all of the following:

- 1) Close a door.
  - 2) Tap or push/pull around the area where the noise appears to be coming from.
  - 3) Rev the engine.
  - 4) Use a floor jack to recreate vehicle "twist".
  - 5) At idle, apply engine load (electrical load, half-clutch on M/T model, drive position on A/T model).
  - 6) Raise the vehicle on a hoist and hit a tire with a rubber hammer.
- Drive the vehicle and attempt to duplicate the conditions the customer states exist when the noise occurs.
  - If it is difficult to duplicate the noise, drive the vehicle slowly on an undulating or rough road to stress the vehicle body.

## CHECK RELATED SERVICE BULLETINS

After verifying the customer concern or symptom, check ASIST for Technical Service Bulletins (TSBs) related to that concern or symptom.

If a TSB relates to the symptom, follow the procedure to repair the noise.

## LOCATE THE NOISE AND IDENTIFY THE ROOT CAUSE

1. Narrow down the noise to a general area. To help pinpoint the source of the noise, use a listening tool (Chassis Ear: J39570, Engine Ear and mechanics stethoscope).
2. Narrow down the noise to a more specific area and identify the cause of the noise by:
  - removing the components in the area that you suspect the noise is coming from.  
Do not use too much force when removing clips and fasteners, otherwise clips and fastener can be broken or lost during the repair, resulting in the creation of new noise.
  - tapping or pushing/pulling the component that you suspect is causing the noise.  
Do not tap or push/pull the component with excessive force, otherwise the noise will be eliminated only temporarily.
  - feeling for a vibration with your hand by touching the component(s) that you suspect is (are) causing the noise.
  - placing a piece of paper between components that you suspect are causing the noise.
  - looking for loose components and contact marks.  
Refer to [EI-7, "Generic Squeak and Rattle Troubleshooting"](#)

## REPAIR THE CAUSE

- If the cause is a loose component, tighten the component securely.
- If the cause is insufficient clearance between components:
  - separate components by repositioning or loosening and retightening the component, if possible.
  - insulate components with a suitable insulator such as urethane pads, foam blocks, felt cloth tape or urethane tape. A Nissan Squeak and Rattle Kit (J43980) is available through your authorized Nissan Parts Department.

### CAUTION:

**Do not use excessive force as many components are constructed of plastic and may be damaged.**

**Always check with the Parts Department for the latest parts information.**

**The following materials are contained in the Nissan Squeak and Rattle Kit (J43980). Each item can be ordered separately as needed.**

**URETHANE PADS [1.5 mm(0.059 in) thick]**

**Insulates connectors, harness, etc.**

**76268-9E005: 100×135mm(3.94×5.31 in)/76884-71L01: 60×85mm(2.36×3.35 in)/76884-71L02: 15×25 mm(0.59×0.98 in)**

**INSULATOR (Foam blocks)**

**Insulates components from contact. Can be used to fill space behind a panel.**

**73982-9E000: 45mm(1.77 in) thick, 50×50mm(1.97×1.97 in)/73982-50Y00: 10mm(0.39 in) thick, 50×50mm(1.97×1.97 in)**

# SQUEAK AND RATTLE TROUBLE DIAGNOSES

## INSULATOR (Light foam block)

80845-71L00: 30 mm(1.18 in) thick, 30×50 mm(1.18×1.97 in)

## FELT CLOTHTAPE

Used to insulate where movement does not occur. Ideal for instrument panel applications.

68370-4B000: 15×25 mm(0.59×0.98 in) pad/68239-13E00: 5 mm(0.20 in) wide tape roll The following materials, not found in the kit, can also be used to repair squeaks and rattles.

## UHMW(TEFLON) TAPE

Insulates where slight movement is present. Ideal for instrument panel applications.

## SILICONE GREASE

Used in of UHMW tape that will be visible or not fit.

Note: Will only last a few months.

## SILICONE SPRAY

Use when grease cannot be applied.

## DUCT TAPE

Use to eliminate movement.

## CONFIRM THE REPAIR

Confirm that the cause of a noise is repaired by test driving the vehicle. Operate the vehicle under the same conditions as when the noise originally occurred. Refer to the notes on the Diagnostic Worksheet.

## Generic Squeak and Rattle Troubleshooting

EIS000ZI

Refer to Table of Contents for specific component removal and installation information.

## INSTRUMENT PANEL

Most incidents are caused by contact and movement between:

1. The cluster lid A and instrument panel
2. Acrylic lens and combination meter housing
3. Instrument panel to front pillar garnish
4. Instrument panel to windshield
5. Instrument panel mounting pins
6. Wiring harnesses behind the combination meter
7. A/C defroster duct and duct joint

These incidents can usually be located by tapping or moving the components to duplicate the noise or by pressing on the components while driving to stop the noise. Most of these incidents can be repaired by applying felt cloth tape or silicon spray (in hard to reach areas).Urethane pads can be used to insulate wiring harness.

### CAUTION:

**Do not use silicone spray to isolate a squeak or rattle. If you saturate the area with silicone, you will not be able to recheck the repair.**

## CENTER CONSOLE

Components to pay attention to include:

1. Shifter assembly cover to finisher
2. A/C control unit and cluster lid C
3. Wiring harnesses behind audio and A/C control unit

The instrument panel repair and isolation procedures also apply to the center console.

## DOORS

Pay attention to the:

1. Finisher and inner panel making a slapping noise
2. Inside handle escutcheon to door finisher
3. Wiring harnesses tapping
4. Door striker out of alignment causing a popping noise on starts and stops

Tapping or moving the components or pressing on them while driving to duplicate the conditions can isolate many of these incidents. You can usually insulate the areas with felt cloth tape or insulator foam blocks from the Nissan Squeak and Rattle Kit (J43980) to repair the noise.

# SQUEAK AND RATTLE TROUBLE DIAGNOSES

---

## TRUNK

Trunk noises are often caused by a loose jack or loose items put into the trunk by the owner. In addition look for:

1. Trunk lid dumpers out of adjustment
2. Trunk lid striker out of adjustment
3. The trunk lid torsion bars knocking together
4. A loose license plate or bracket

Most of these incidents can be repaired by adjusting, securing or insulating the item(s) or component(s) causing the noise.

## SUNROOF/HEADLINER

Noises in the sunroof/headliner area can often be traced to one of the following:

1. Sunroof lid, rail, linkage or seals making a rattle or light knocking noise
2. Sunvisor shaft shaking in the holder
3. Front or rear windshield touching headliner and squeaking

Again, pressing on the components to stop the noise while duplicating the conditions can isolate most of these incidents. Repairs usually consist of insulating with felt cloth tape.

## SEATS

When isolating seat noise it's important to note the position the seat is in and the load placed on the seat when the noise is present. These conditions should be duplicated when verifying and isolating the cause of the noise.

Cause of seat noise include:

1. Headrest rods and holder
2. A squeak between the seat pad cushion and frame
3. The rear seat back lock and bracket

These noises can be isolated by moving or pressing on the suspected components while duplicating the conditions under which the noise occurs. Most of these incidents can be repaired by repositioning the component or applying urethane tape to the contact area.

## UNDERHOOD

Some interior noise may be caused by components under the hood or on the engine wall. The noise is then transmitted into the passenger compartment.

Causes of transmitted underhood noise include:

1. Any component mounted to the engine wall
2. Components that pass through the engine wall
3. Engine wall mounts and connectors
4. Loose radiator mounting pins
5. Hood bumpers out of adjustment
6. Hood striker out of adjustment

These noise can be difficult to isolate since they cannot be reached from the interior of the vehicle. The best method is to secure, move or insulate one component at a time and test drive the vehicle. Also, engine RPM or load can be changed to isolate the noise. Repairs can usually be made by moving, adjusting securing, or insulating the component causing the noise.



# SQUEAK AND RATTLE TROUBLE DIAGNOSES

## Diagnostic Worksheet

EIS000ZJ



### SQUEAK & RATTLE DIAGNOSTIC WORKSHEET

Dear Infiniti Customer:

We are concerned about your satisfaction with your Infiniti vehicle. Repairing a squeak or rattle sometimes can be very difficult. To help us fix your Infiniti right the first time, please take a moment to note the area of the vehicle where the squeak or rattle occurs and under what conditions. You may be asked to take a test drive with a service advisor or technician to ensure we confirm the noise you are hearing.

#### I. WHERE DOES THE NOISE COME FROM? (circle the area of the vehicle)

The illustrations are for reference only, and may not reflect the actual configuration of your vehicle.

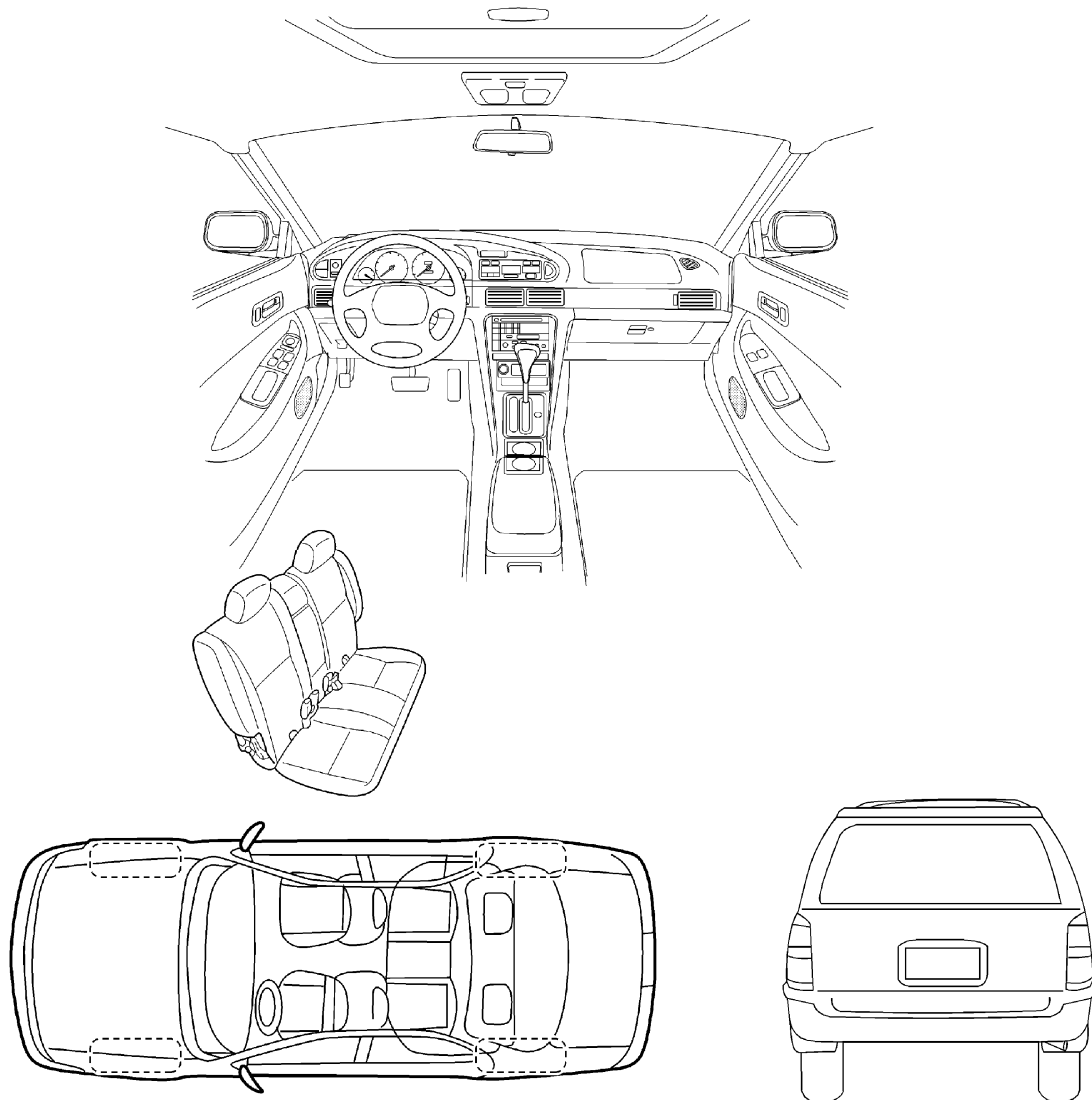

Continue to the back of the worksheet and briefly describe the location of the noise or rattle. In addition, please indicate the conditions which are present when the noise occurs.

SBT860

A  
B  
C  
D  
E  
F  
G  
H  
EI  
J  
K  
L  
M

# SQUEAK AND RATTLE TROUBLE DIAGNOSES

## SQUEAK & RATTLE DIAGNOSTIC WORKSHEET- page 2

Briefly describe the location where the noise occurs:

---

---

---

### II. WHEN DOES IT OCCUR? (check the boxes that apply)

- |  |   |
|--|---|
| <input type="checkbox"/> anytime                             | <input type="checkbox"/> after sitting out in the sun |
| <input type="checkbox"/> 1 <sup>st</sup> time in the morning | <input type="checkbox"/> when it is raining or wet    |
| <input type="checkbox"/> only when it is cold outside        | <input type="checkbox"/> dry or dusty conditions      |
| <input type="checkbox"/> only when it is hot outside         | <input type="checkbox"/> other: _____                 |

### III. WHEN DRIVING:

- through driveways
- over rough roads
- over speed bumps
- only at about \_\_\_\_ mph
- on acceleration
- coming to a stop
- on turns : left, right or either (circle)
- with passengers or cargo
- other: \_\_\_\_\_
- after driving \_\_\_\_ miles or \_\_\_\_ minutes

### IV. WHAT TYPE OF NOISE?

- squeak (like tennis shoes on a clean floor)
- creak (like walking on an old wooden floor)
- rattle (like shaking a baby rattle)
- knock (like a knock on a door)
- tick (like a clock second hand)
- thump (heavy, muffled knock noise)
- buzz (like a bumble bee)

### TO BE COMPLETED BY DEALERSHIP PERSONNEL

#### Test Drive Notes:

---

---

	YES	NO	Initials of person performing
Vehicle test driven with customer	<input type="checkbox"/>	<input type="checkbox"/>	_____
- Noise verified on test drive	<input type="checkbox"/>	<input type="checkbox"/>	_____
- Noise source located and repaired	<input type="checkbox"/>	<input type="checkbox"/>	_____
- Follow up test drive performed to confirm repair	<input type="checkbox"/>	<input type="checkbox"/>	_____

VIN: \_\_\_\_\_ Customer Name: \_\_\_\_\_

W.O. #: \_\_\_\_\_ Date: \_\_\_\_\_

SBT844

**This form must be attached to Work Order**

# CLIP AND FASTENER

---

## CLIP AND FASTENER

PFP:76906

### Description

EIS00002

- Clips and fasteners in EI section correspond to the following numbers and symbols.

A

B

C

D

E

F

G

H

**EI**

J







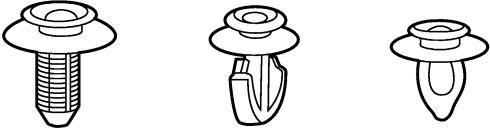

K

L

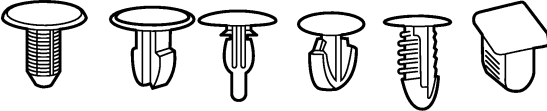
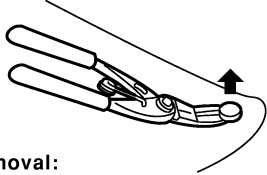
M

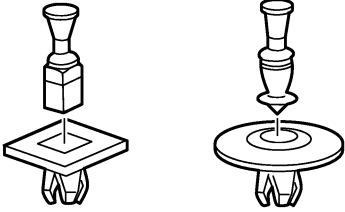
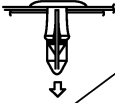
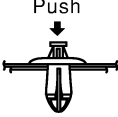

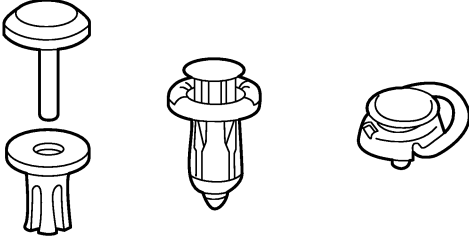

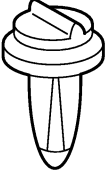
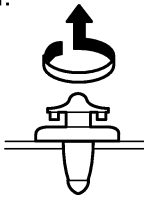



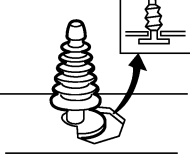
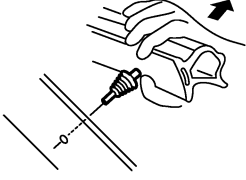

# CLIP AND FASTENER

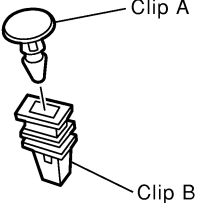
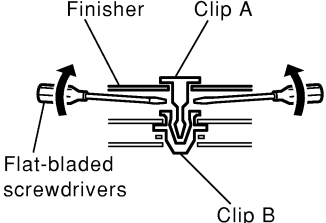
- Replace any clips and/or fasteners which are damaged during removal or installation.

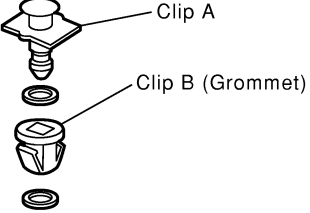
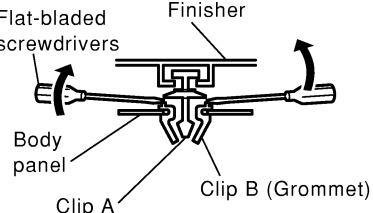
Symbol No.	Shapes	Removal & Installation
<p>C101</p> 		<p><b>Removal:</b> Remove by bending up with flat-bladed screwdrivers or clip remover.</p> 
<p>C103</p> 		<p><b>Removal:</b> Remove with a clip remover.</p> 
<p>C203</p> 		<p><b>Removal:</b> Push center pin to catching position. (Do not remove center pin by hitting it.)</p> <p>Push</p>  <p><b>Installation:</b></p> <p>Push</p> 
<p>C205</p> 		<p><b>Removal:</b> Flat-bladed screwdriver</p>  <p>Clip</p> <p>Finisher</p>
<p>C206</p> 		<p><b>Removal:</b></p> 

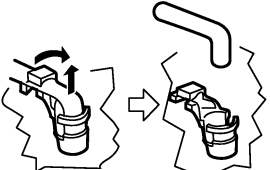
SIIA0315E

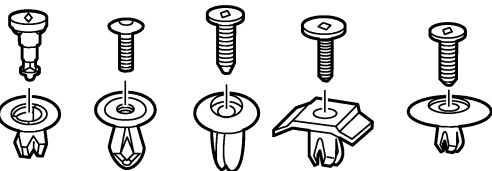







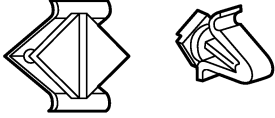

# CLIP AND FASTENER

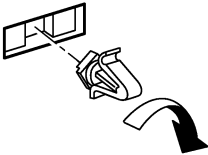
Symbol No.	Shapes	Removal & Installation
<p>CE103</p> 		<p><b>Removal:</b></p> 
<p>CF110</p> 		<p><b>Removal:</b></p> 
<p>CF118</p> 		<p><b>Removal:</b></p> 
<p>CR103</p> 		<p><b>Removal:</b> Holder portion of clip must be spread out to remove rod.</p> 
<p>CS101</p> 		<p><b>Removal:</b></p> <ol style="list-style-type: none"> <li>1. Screw out with a Phillips screwdriver.</li> <li>2. Remove female portion with flat-bladed screwdriver.</li> </ol> 

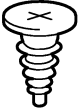
SIIA0316E

A  
B  
C  
D  
E  
F  
G  
H  
EI  
J  
K  
L  
M

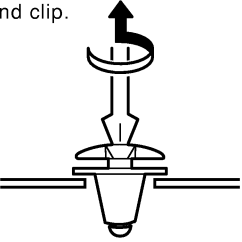
# CLIP AND FASTENER

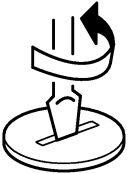
Symbol No.	Shapes	Removal & Installation	
<p>CG101</p> 		<p><b>Removal:</b></p>  <p>Rotate 45° to remove</p>	<p><b>Installation:</b></p> 
<p>CS102</p> 			
<p>CS113</p> 		<p><b>Removal:</b> Disconnect upper connection of clip with a flat-bladed screwdriver, then remove clip while inserting a flat-bladed screwdriver between body panel and clip.</p> 	
<p>C111</p> 			

SIIA0317E

# FRONT BUMPER

PF:F2022

EIS0013H

## FRONT BUMPER

### Removal and Installation

**CAUTION:**

Bumper fascia is made of plastic. Do not use excessive force and be sure to keep oil away from it.

**SEC. 620**

**A**

★ Bolt  
4.3 - 5.9  
(0.44 - 0.60, 38 - 52)

**B**

★ Bolt  
4.3 - 5.9  
(0.44 - 0.60, 38 - 52)

**C**

Clip  
(CS101)

**D**

★ Screw

**E**

★ (CS101) Clip

**F**

★ Nut  
Clip  
★ Bolt  
4.3 - 5.9  
(0.44 - 0.60, 38 - 52)

**G**

Nut  
10.8 - 14.7  
(1.10 - 1.50, 8 - 10)

Clearance measurement between parts  
 A:  $0 + 0.5$  (0 + 0.020)  
 B:  $2.5 \pm 1.5$  (0.098  $\pm$  0.059)  
 C:  $1.5 \pm 1.0$  (0.059  $\pm$  0.039)  
 Unit: mm (in)

: N•m (kg-m, in-lb)  
 : N•m (kg-m, ft-lb)  
 ★ : Bumper assembly mounting bolts, nuts and clips

PHIA0034E

A  
B  
C  
D  
E  
F  
G  
H  
I  
J  
K  
L  
M

### REMOVAL

1. Release front air cover clips, and remove front air guide.

## FRONT BUMPER

---

2. Remove front grille. Refer to [EI-19, "FRONT GRILLE"](#) .
3. Remove bolts at the edge of engine undercover. (Refer to A shown in the figure)
4. Remove bolts and clips of both right/left front fender protectors (on front side). (Refer to B and C shown in the illustration)
5. Remove bumper fascia screws from both right/left front fenders. (Refer to D shown in the figure)
6. Remove bumper fascia clips from upper bracket assembly. (Refer to E shown in the figure)
7. Remove bumper fascia assembly.
8. Remove bumper reinforcement nuts. (Refer to G shown in the figure)
9. Remove bumper upper retainer bolts and nuts. (Refer to F shown in the figure)

### **INSTALLATION**

Install in the reverse order of removal.



# REAR BUMPER

PFP:H5022

EIS00131

## REAR BUMPER

### Removal and Installation

**CAUTION:**

- Bumper fascia is made of resin; do not apply pressure to or let oils contact its surface.

**SEC. 850**

Energy absorber  
Side bracket (retained with ribbet)  
Bumper reinforcement  
Bumper fascia assembly

**A** **B** **C** **D** **E** **F** **G** **H**

Clearance measurement between parts  
A:  $0 + 0.5$  ( $0 + 0.020$ )  
B:  $2.0 \pm 1.5$  ( $0.079 \pm 0.059$ )  
Unit: mm (in)

: N·m (kg-m, in-lb)  
 : N·m (kg-m, ft-lb)  
 ★ : Bumper assembly mounting bolts, nuts and clips

**A** **C103** Clip

**B** Screw Screw

**C** ★ Screw

**D** ★ **C205** Clip

**E** Retainer ★ Bolt Nut

**F** ★ Bolt

**G** Clip

Fascia  
Clip  
Bumper retainer  
Rear panel

**H** Nut

**G** 10.8 - 14.7  
(1.10 - 1.50, 8 - 10)

**E** 4.3 - 5.9  
(0.44 - 0.60, 38 - 52)

**F** 4.3 - 5.9  
(0.44 - 0.60, 38 - 52)

PHIA0035E

A  
B  
C  
D  
E  
F  
G  
H  
EI  
J  
K  
L  
M

# REAR BUMPER

## REMOVAL

1. Remove trunk trim. Refer to [EI-52, "Removal and Installation"](#) .
2. Remove rear combination lamp assembly. Refer to [LT-80, "REAR COMBINATION LAMP"](#) .
3. Remove bumper fascia screws from both right/left rear fender. (Refer to B and C shown in figure)
4. Remove both right/left fender protector clips and screws, and remove fender protector. (Refer to A and B shown in figure)
5. Remove bumper fascia clips. (Refer to D shown in figure)
6. Remove bumper fascia bolts and nuts. (Refer to E and F shown in figure)
7. Pull out center of bumper fascia, and remove bumper fascia from clips. (Refer to G shown in figure)
8. Remove bumper fascia assembly.
9. Remove bumper reinforcement assembly nuts. (Refer to H shown in figure)

### CAUTION:

To remove rear bumper molding, remove rear bumper center molding first, then rear bumper side molding, respectively.

## INSTALLATION

Install in the reverse order of removal.

### Removal of Bumper Side Brackets

Shave head of rivet with drill (4.0 to 4.5 mm dia).

### Installation of Bumper Side Brackets

Install bracket to fascia firmly with hand riveter.

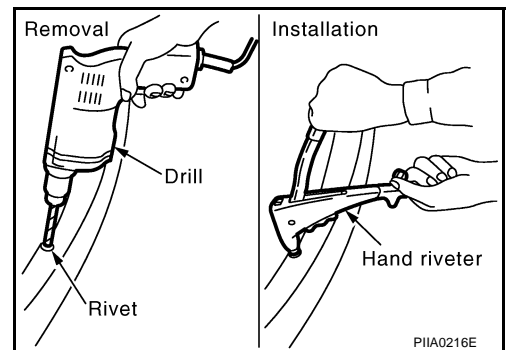

# FRONT GRILLE

## FRONT GRILLE

PFP:62310

### Removal and Installation

EIS0013J

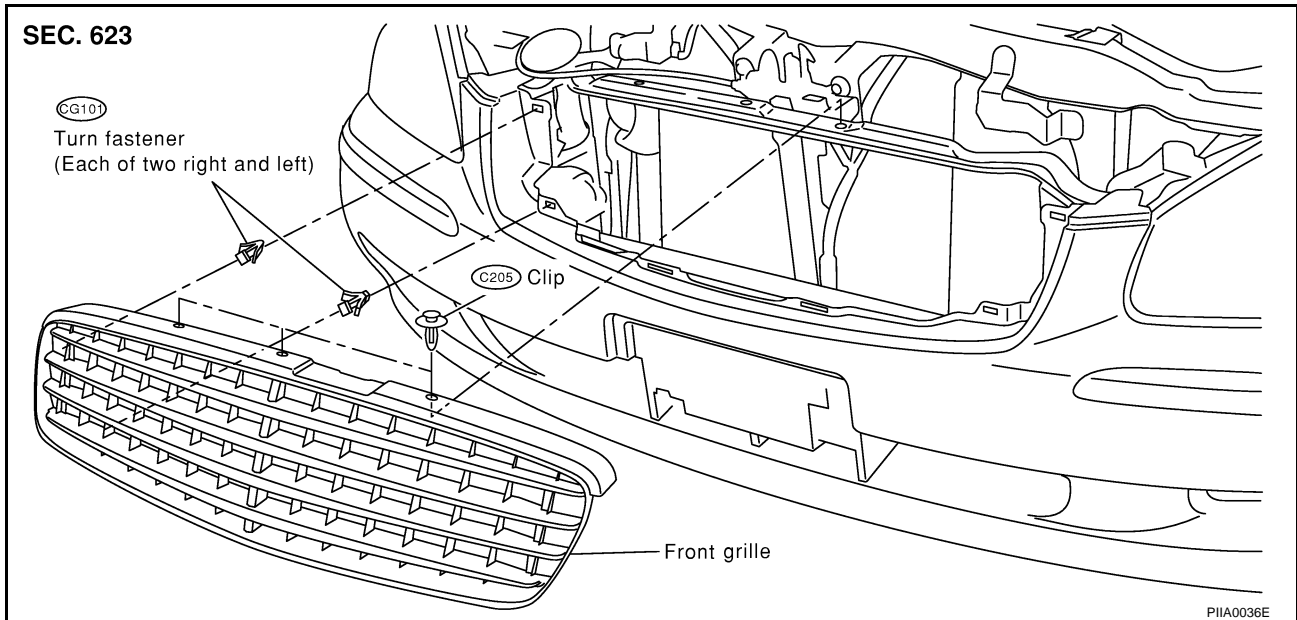

### REMOVAL

1. Apply protection tapes around outer circumference of front grille (bumper fascia side).
2. Remove clips on upper side of grille.
3. Push down tips of four turn fasteners from rear side of grille. Pull out grille. Disconnect turn fasteners and remove grille.

### INSTALLATION

Install in the reverse order of removal.

A  
B  
C  
D  
E  
F  
G  
H  
EI  
J  
K  
L  
M

# COWL TOP

## COWL TOP

PFP:66100

## Removal and Installation

EIS0013K

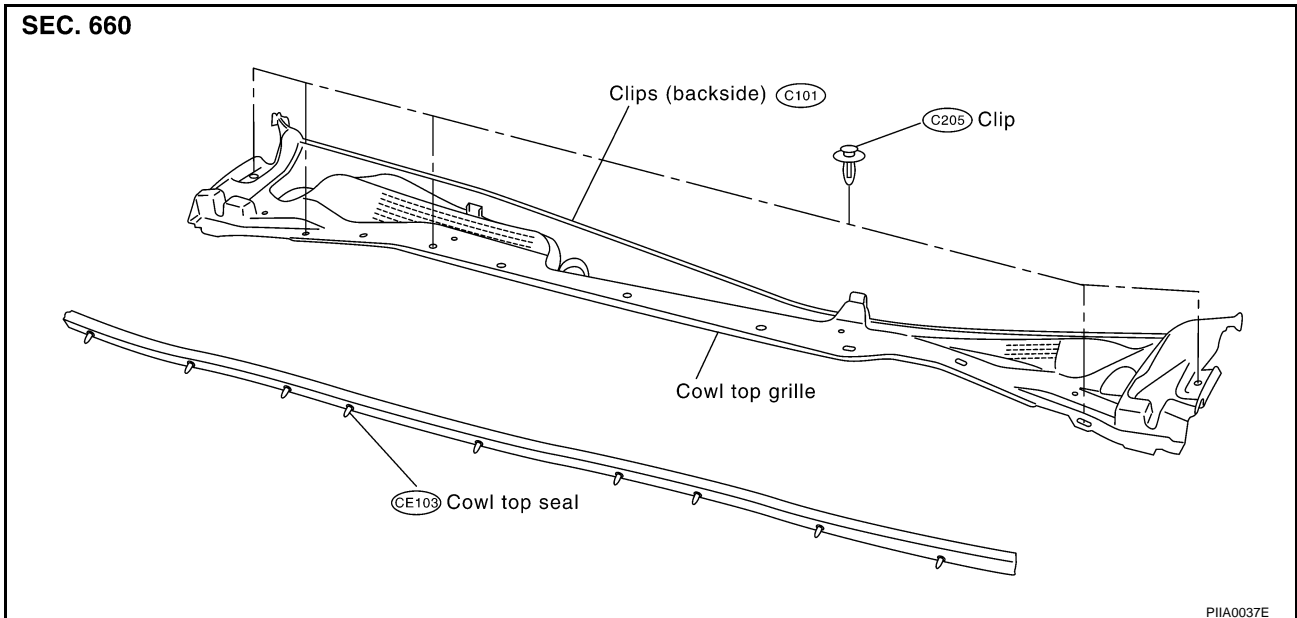

### REMOVAL

1. Remove both right/left wiper arms from vehicle. Refer to [WW-19, "Removal and Installation for Front Wiper Arms, Adjustment for Front Wiper Arms Stop Location"](#) .
2. Remove brake fluid check cover and ABS unit cover. Refer to [EM-11, "Removal and Installation"](#) .
3. Remove clips of both cowl top seal rubber and cowl top cover, then remove cowl top cover.

### INSTALLATION

Install in the reverse order of removal.

# FENDER PROTECTOR

## FENDER PROTECTOR Removal and Installation

PFP:63840

EIS000DA

A  
B  
C  
D  
E  
F  
G  
H  
EI  
J  
K  
L  
M

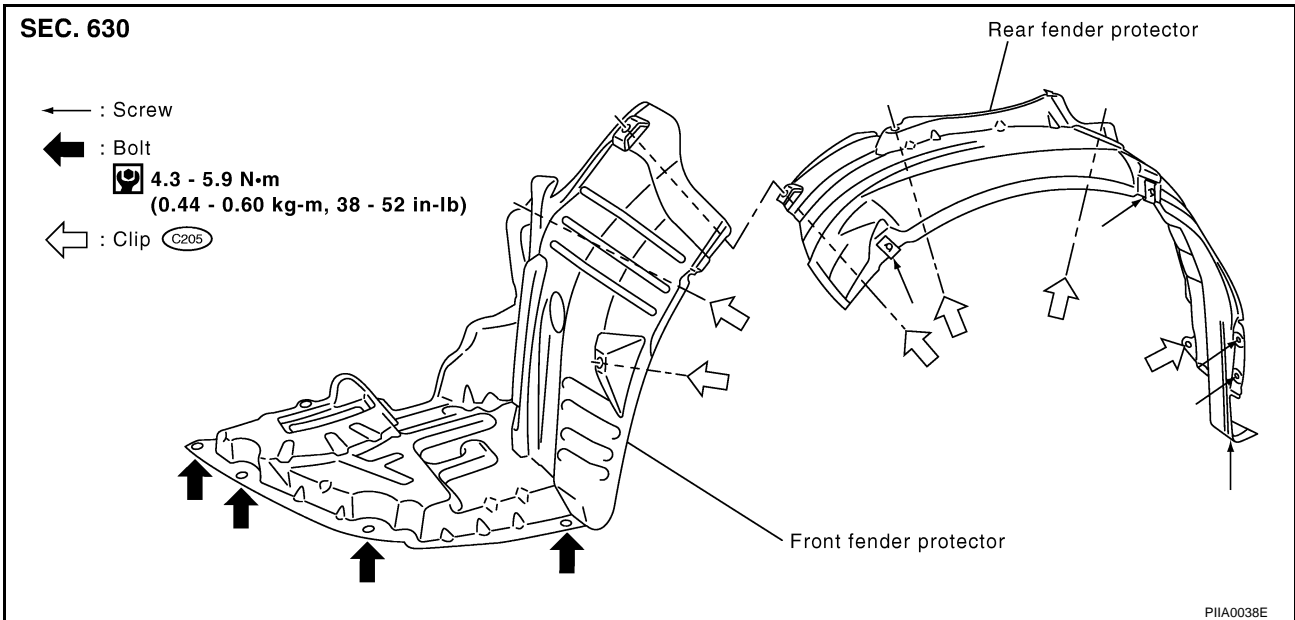

### REMOVAL

1. Remove bolts and clips of fender protector.
2. Remove fender protector (front/rear).

### INSTALLATION

Install in the reverse order of removal.

# MUDGUARD

## MUDGUARD

PFP:63854

### Removal and Installation

EIS0013L

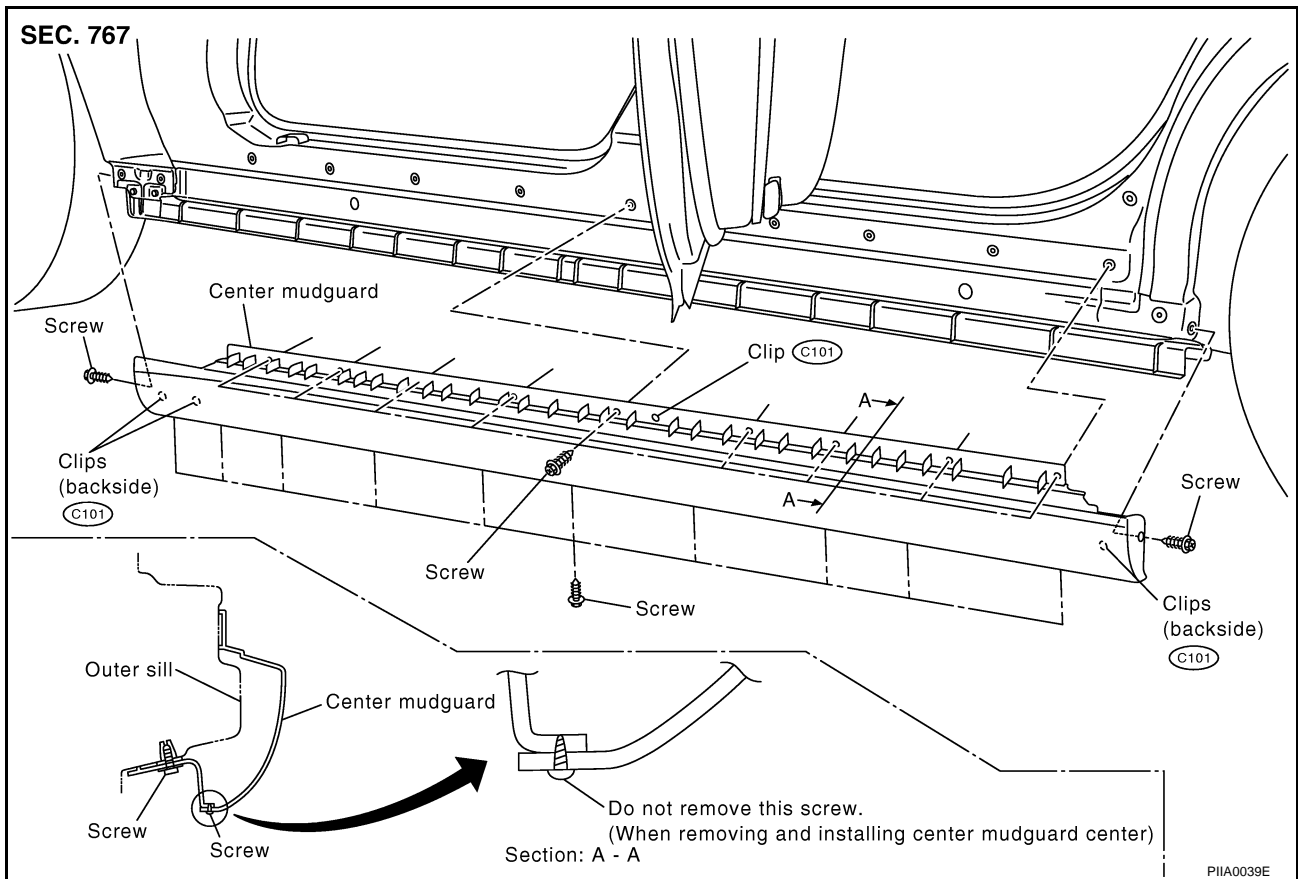

### REMOVAL

1. Remove mudguard finisher. Refer to [EI-37, "Removal and Installation"](#).
2. Remove screws on front and lower side of center mudguard.
3. Remove clips on front and rear end of center mudguard.
4. Remove center mudguard.

### INSTALLATION

Install in the reverse order of removal.

# WINDSHIELD MOLDING

PFP:72700

EIS0013M

## WINDSHIELD MOLDING

### Removal and Installation

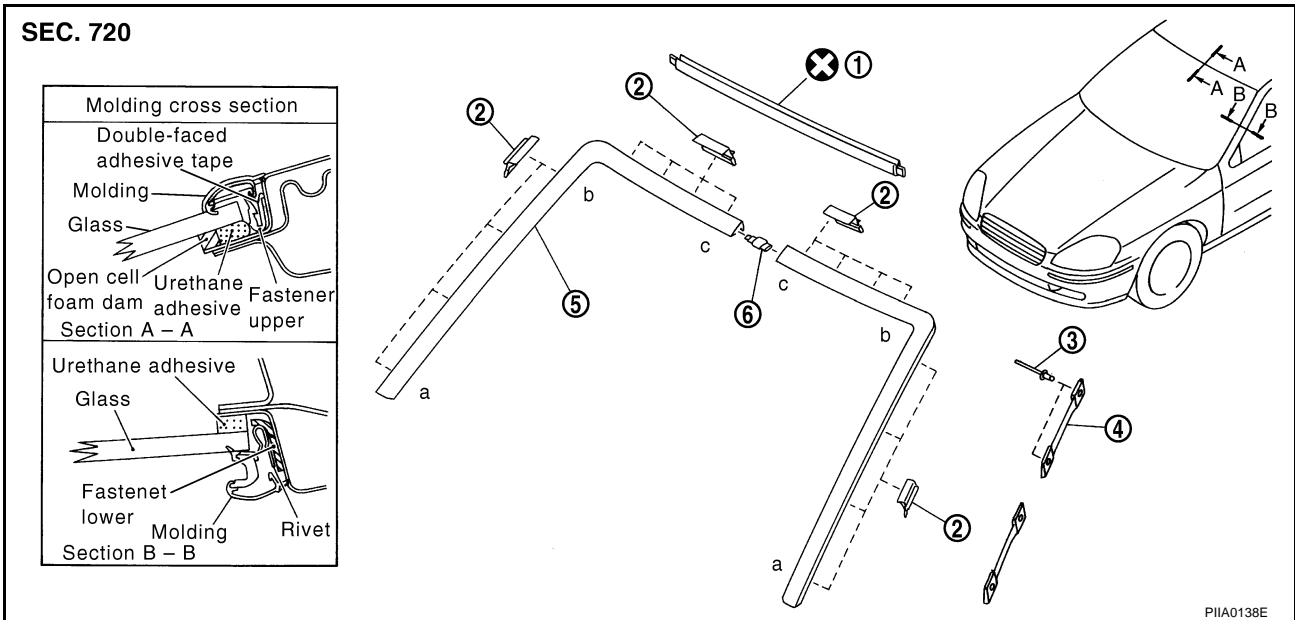

- |                     |                       |          |
|---------------------|-----------------------|----------|
| 1. Fastener (upper) | 2. Clip               | 3. Rivet |
| 4. Fastener (lower) | 5. Windshield molding | 6. Joint |

### REMOVAL

1. Apply protective tape around outer circumference of windshield molding.
2. Remove clips in order of a and b. Pull upper part to outer side of vehicle.

### INSTALLATION

1. Cut double-faced adhesive tape of fastener with cutter knife. Remove fastener (upper).
2. Remove any excess glue on windshield or flange with cutter knife.

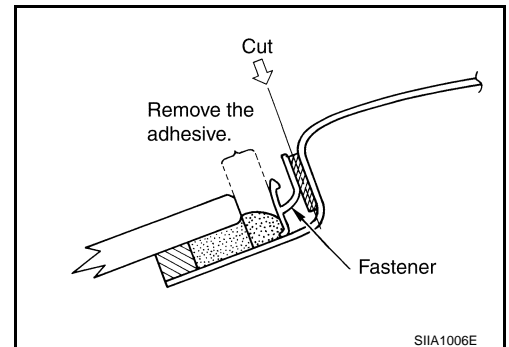

3. Remove remains of double-faced adhesive tape on flange with remover.

### CAUTION:

**Do not handle remover around fire or flame, or in closed areas.**

4. Fix double-faced adhesive tape on new fastener on flange from center of vehicle to outer side with spatula.

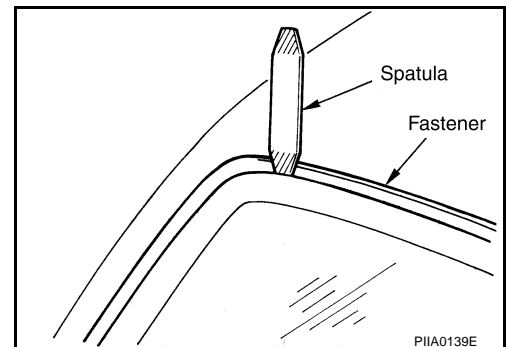

## WINDSHIELD MOLDING

5. Connect clips in order of a and b.
6. Connect joint 6, then clips in order of b and c.

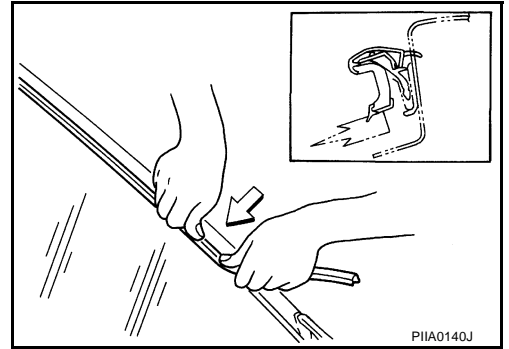



# DRIP MOLDING

## DRIP MOLDING

PFP:76810

### Removal and Installation

EIS009BZ

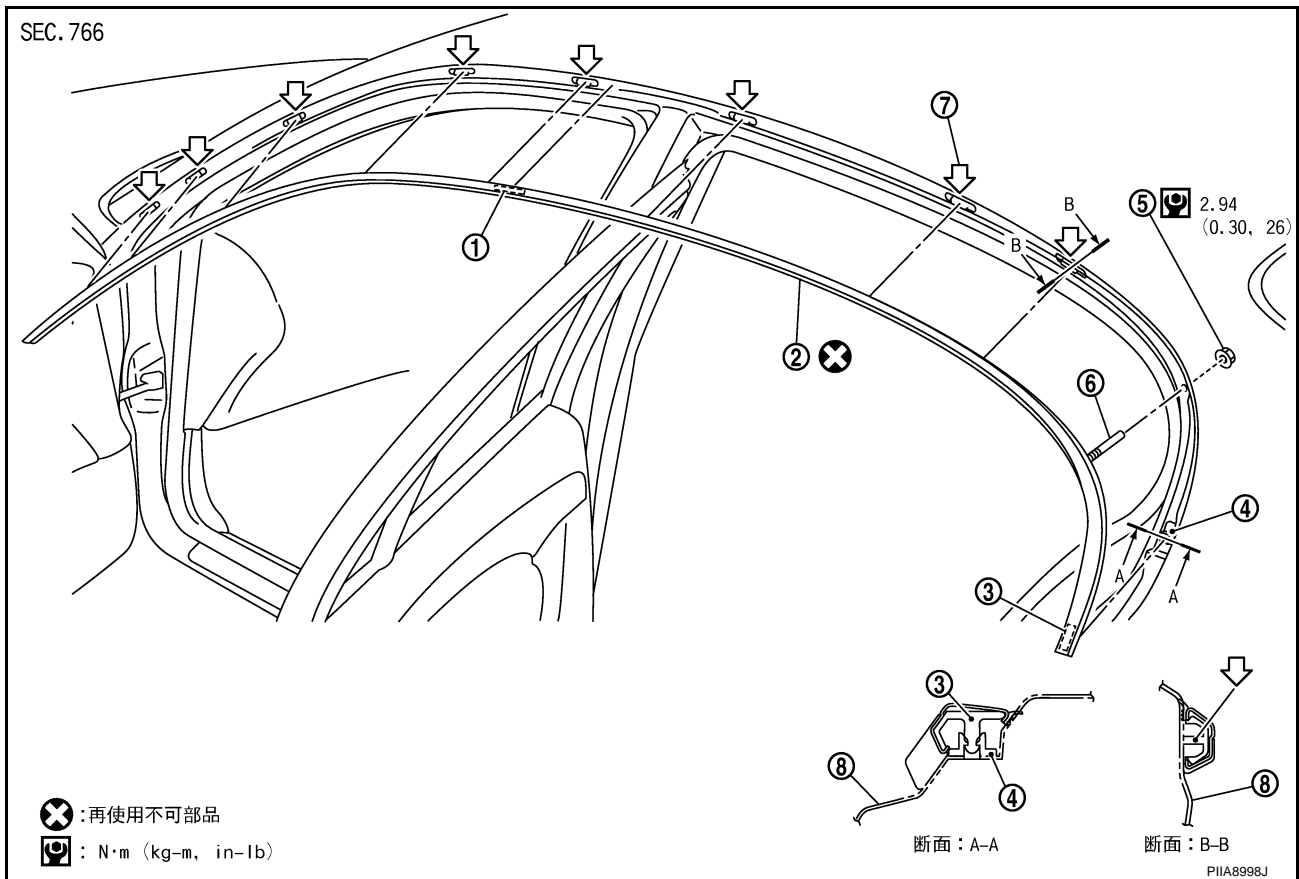

- |                         |                          |                            |
|-------------------------|--------------------------|----------------------------|
| 1. Stopper              | 2. Drip molding          | 3. Clip A-A (molding side) |
| 4. Grommet (body side)  | 5. Nut                   | 6. Clip (with stud bolt)   |
| 7. Clip B-B (body side) | 8. Body side panel outer |                            |

### REMOVAL

1. Remove rear seat cushion. Ref to [SE-197, "REAR SEAT"](#) .
2. Remove rear wheelhouse garnish and remove rear pillar finisher. Ref to [EI-37, "BODY SIDE TRIM"](#) .
3. Remove nut of drip molding from inside body.
4. Disconnect clip A-A of drip molding from body side grommet.
5. Disconnect drip molding from body side clips B-B.
6. Pull out clip (with stud bolt) and remove drip molding.

### INSTALLATION

Install in the reverse order of removal.

#### CAUTION:

- Insert clip (with stud bolt). Hold stopper part to avoid coming over clip B-B, and connect clip A-A.
- Connect clip B-B in order from rear side.

# ROOF SIDE MOLDING

## ROOF SIDE MOLDING

PFP:73854

### Removal and Installation

EIS000DF

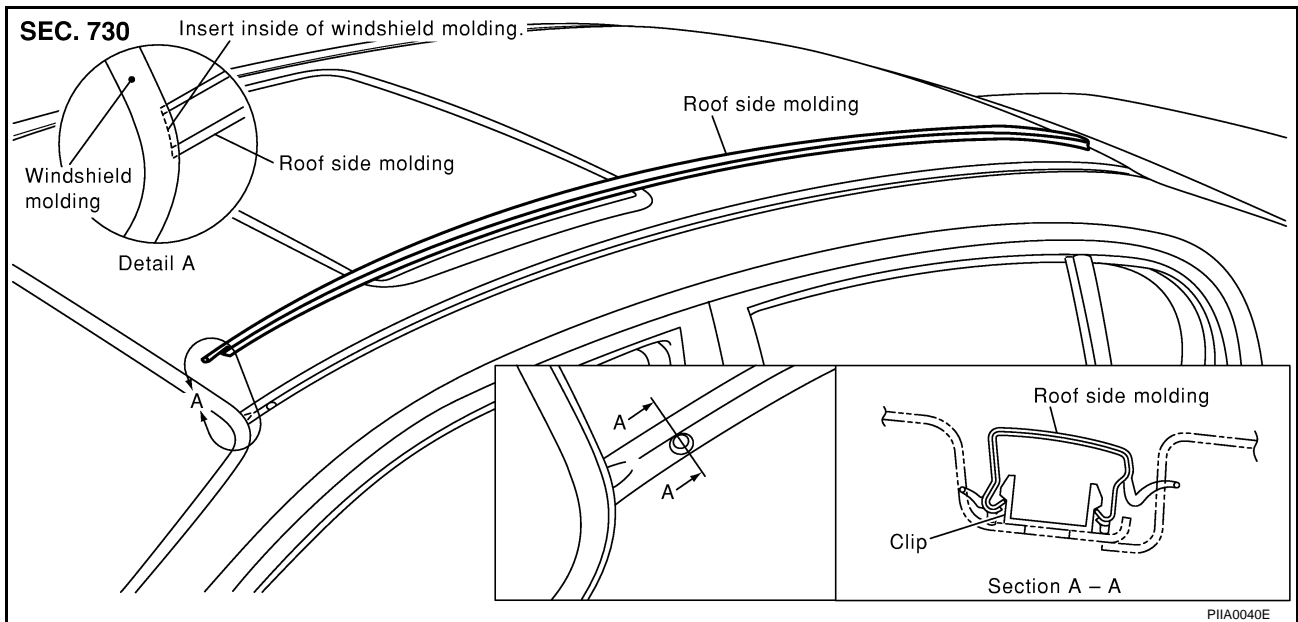

#### REMOVAL

Lift and twist roof side molding up from rear edge. Disengage clips, and remove roof side molding.

#### INSTALLATION

Install in the reverse order of removal.

#### CAUTION:

To install roof side molding, always insert its front edge part inside of windshield molding.

# DOOR OUTSIDE MOLDING

## DOOR OUTSIDE MOLDING

PF82820

### Removal and Installation

EIS000DG

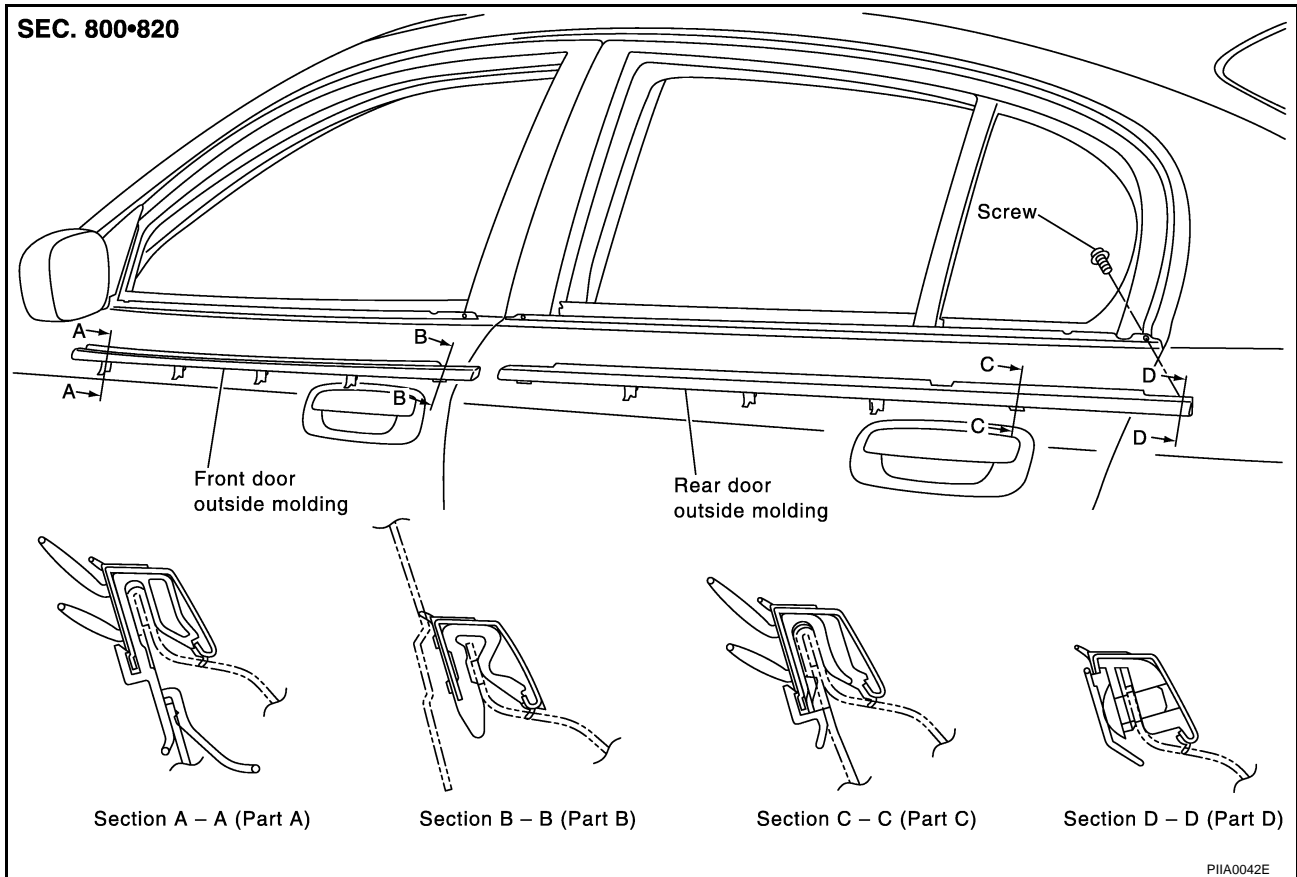

### FRONT DOOR OUTSIDE MOLDING

#### Removal

1. Open windows fully.
2. Lift up rear edge, push down center tip of clip, and pull out molding.
3. Lift and twist from rear side, disengage clips from flange, and pull out molding to backward.

#### Installation

Install in the reverse order of removal.

### REAR DOOR OUTSIDE MOLDING

#### Removal

1. Open windows fully.
2. Remove screws on rear edge.
3. Lift and twist from rear side, and disengage clips from flange.
4. Push down center tip of clip B, pull out and remove molding.

#### Installation

Install in the reverse order of removal.

A  
B  
C  
D  
E  
F  
G  
H  
EI  
J  
K  
L  
M

# SIDE GUARD MOLDING

## SIDE GUARD MOLDING

PFP:76840

### Removal and Installation

EIS000DH

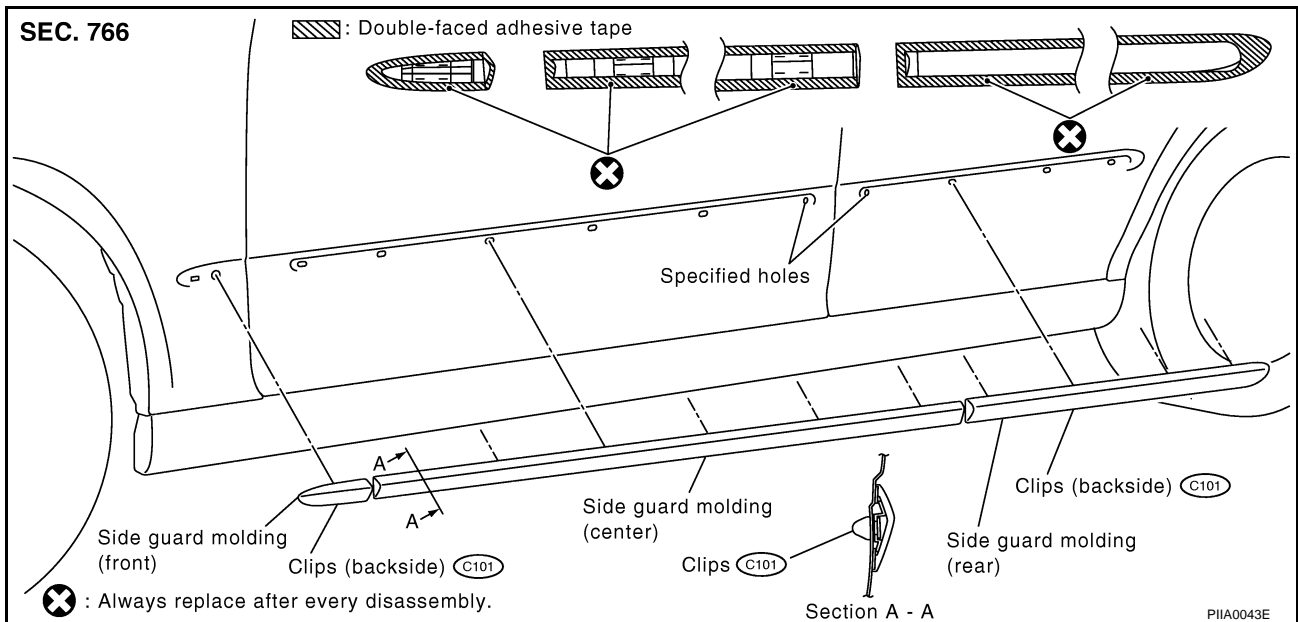

### REMOVAL

1. Apply masking tape around outer circumference of side guard molding.
2. Remove double-faced adhesive tapes with (wide) resin spatula. Disengage clips and remove side guard molding.

### INSTALLATION

1. Remove double-faced adhesive tape remaining on vehicle.
2. Clean contact surface of vehicle (to side guard molding), and install side guard molding to vehicle.

#### NOTE:

To re-use side guard molding, follow above steps 1 and 2 as well; clean surface after removing double-faced adhesive tape, apply new double-faced adhesive tape as shown in illustration, then install side guard molding to vehicle.

Double-faced adhesive tape

thickness: 6 mm (0.24 in) (upper side)
thickness: 8 mm (0.31 in) (lower side)

### CAUTION:

- Do not let air between contact surfaces when installing.
- To secure contact, do not wash vehicle within 24 hours after installation.

# LICENSE LAMP FINISHER

## LICENSE LAMP FINISHER

PFP:84810

### Removal and Installation

EIS0013P

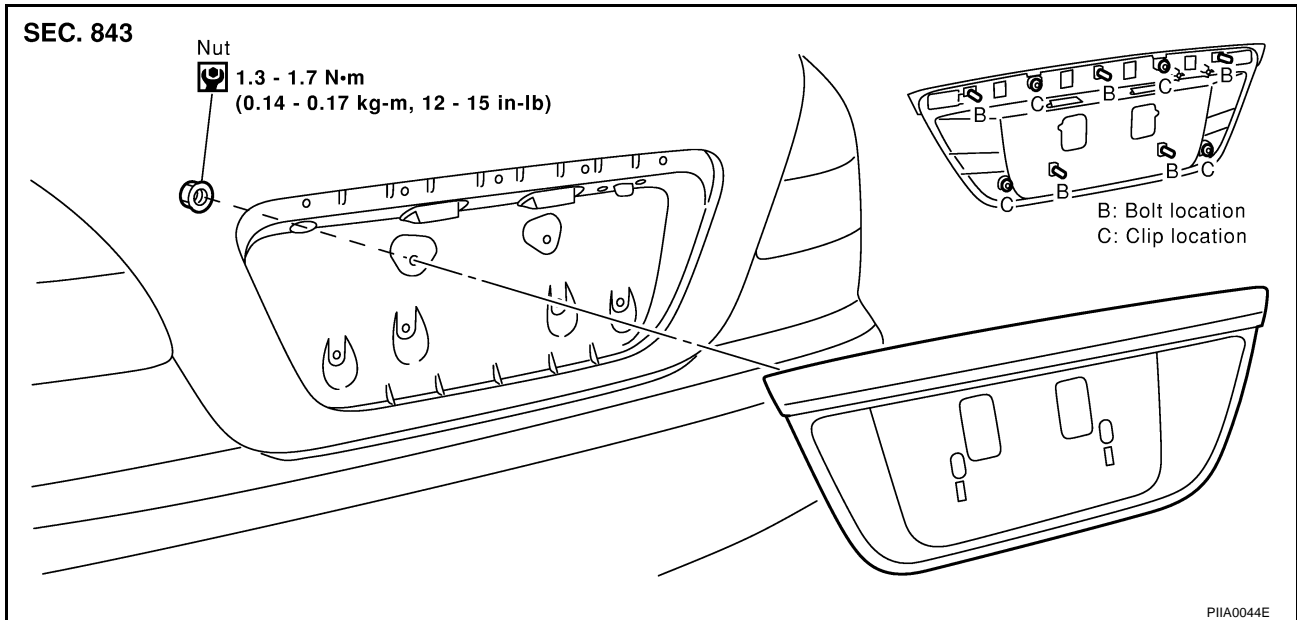

#### REMOVAL

1. Remove trunk lid finisher. Refer to [EI-52, "Removal and Installation"](#).
2. Remove nuts and clips on trunk lid of license lamp finisher.

#### INSTALLATION

Install in the reverse order of removal.

A  
B  
C  
D  
E  
F  
G  
H  
EI  
J  
K  
L  
M

# DOOR FINISHER

## DOOR FINISHER

PFP:80900

### Removal and Installation

EIS000DJ

SEC. 251•800•805•809•820•825•828

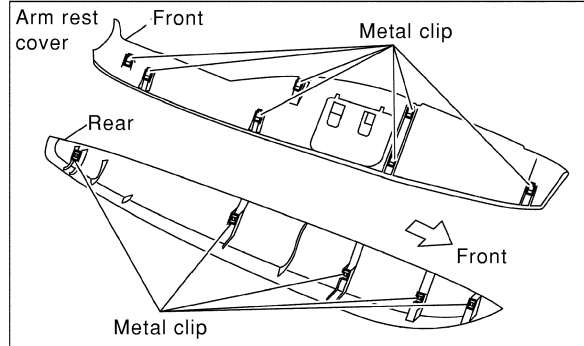
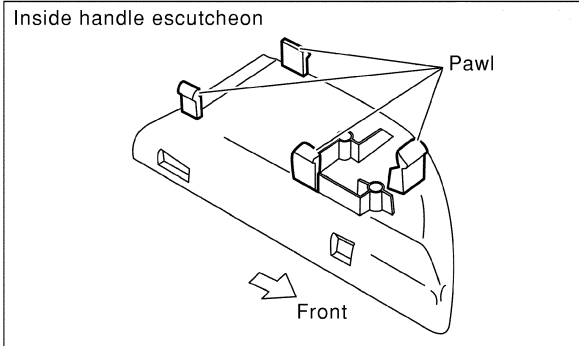
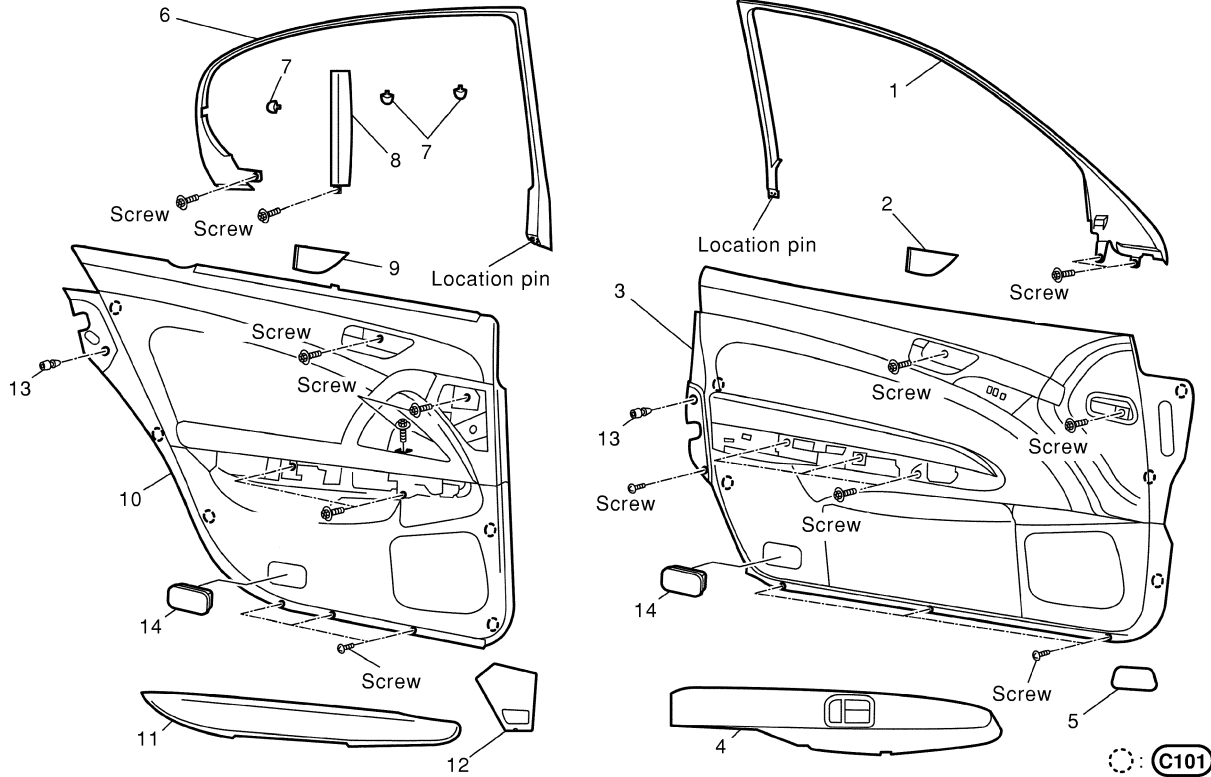

SIIA0805E

- |                           |                                     |                                    |
|---------------------------|-------------------------------------|------------------------------------|
| 1. Front door sash cover  | 2. Inside handle escutcheon (front) | 3. Front door finisher             |
| 4. Front armrest finisher | 5. Front door upper finisher        | 6. Rear door sash cover            |
| 7. Hook                   | 8. Rear side sunshade               | 9. Inside handle escutcheon (rear) |
| 10. Rear door finisher    | 11. Rear armrest finisher           | 12. Rear door lower finisher       |
| 13. Bumper rubber         | 14. Step lamp                       |                                    |

# DOOR FINISHER

## FRONT DOOR FINISHER

### Removal

1. Insert screw driver rolled with cloth or tapes into dip at rear of inside handle escutcheon, and pull it back to your side. Disconnect upper pawl, lower and front, and remove inside handle escutcheon.
2. Insert clip screw driver rolled with cloth into dip under arm-rest finisher, and lift up finisher. Insert your fingers between gaps, pull it back to your side and disconnect metal clips.
3. Disconnect trunk lid opener and fuel lid opener switch connector.
4. Insert screw driver rolled with cloth under front part of front door upper finisher, pull it back to your side and remove it.
5. Disconnect power window switch connector under arm-rest.
6. Remove step lamp, and disconnect connectors.
7. Remove nine screws of door finisher.
8. Insert screw driver rolled with cloth into clips under door finisher, and disconnect clips.
9. Pull up door finisher, and remove connectors, inside handle cable and lock knob cable.

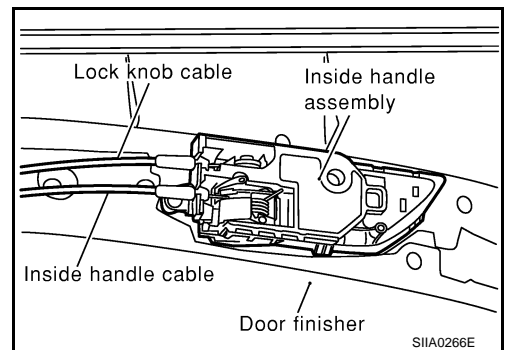
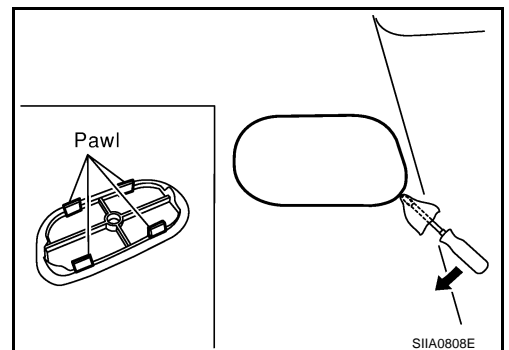
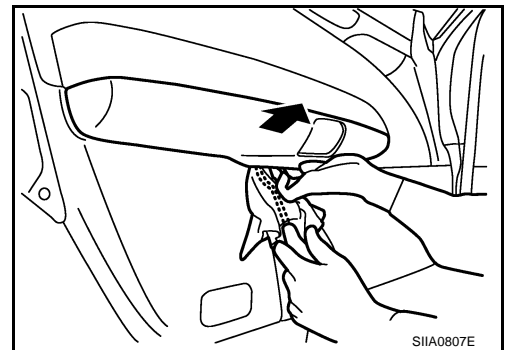
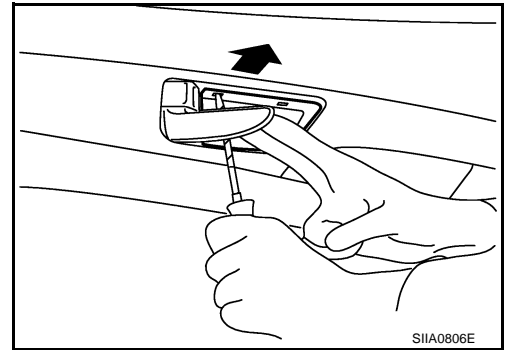

A  
B  
C  
D  
E  
F  
G  
H  
EI  
J  
K  
L  
M

# DOOR FINISHER

## NOTE:

Insert screw driver rolled with cloth between panel on vehicle and clips (as indicated with arrow), and remove finisher.

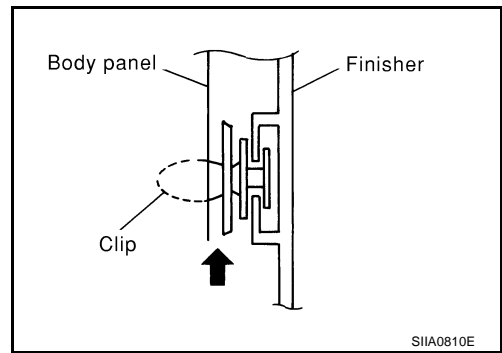

## Installation

Install in the reverse order of removal.

## CAUTION:

To install finisher, check if all clips are matched over holes of panel on vehicle, then push in.

## REAR DOOR FINISHER

### Removal

1. Insert screw driver rolled with cloth or tape into dip at rear of inside handle escutcheon, and pull it back to your side. Disengage upper pawls, lower and front, and remove inside handle escutcheon.

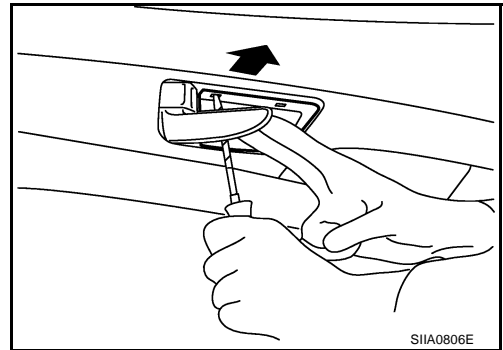

2. Insert screw driver rolled with cloth into dip under arm-rest finisher, and lift up finisher. Insert your fingers between gaps, pull it back to your side, and disconnect metal clips.

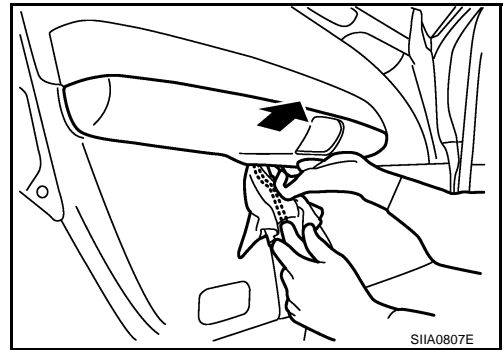

3. Insert screw driver rolled with cloth under rear door lower finisher, and pull it back to your side. Remove rear door lower finisher and disconnect connectors.

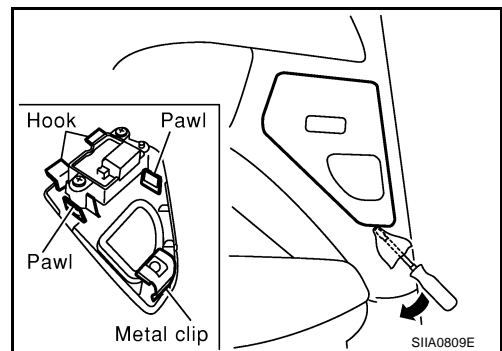

4. Disconnect power window switch connector under arm-rest.
5. Remove step lamp, and disconnect connectors.
6. Remove seven screws of door finisher.



## DOOR FINISHER

7. Insert screw driver rolled with was cloth into clips of door finisher, and disconnect clips.
8. Pull up door finisher, and remove connectors, inside handle cable and lock knob cable.

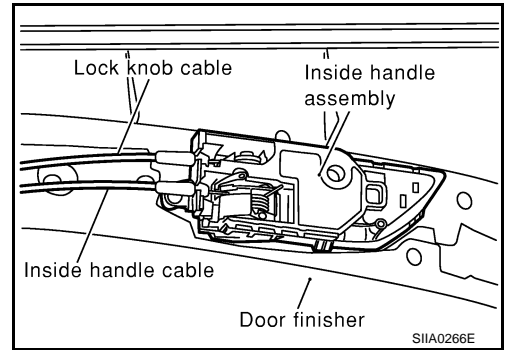

### NOTE:

Insert screw driver rolled with cloth between panel on vehicle and clips (as indicated with arrow), and remove finisher.

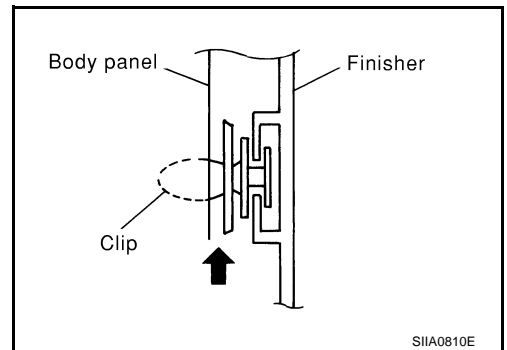

### Installation

Install in the reverse order of removal.

### CAUTION:

To install finisher, check if all clips are matched over holes of panel on vehicle, then push in.

## DOOR SASH COVER

### Removal

1. Remove hooks (rear).
2. Remove screws, and remove door sash slowly in order from its front part to rear part.

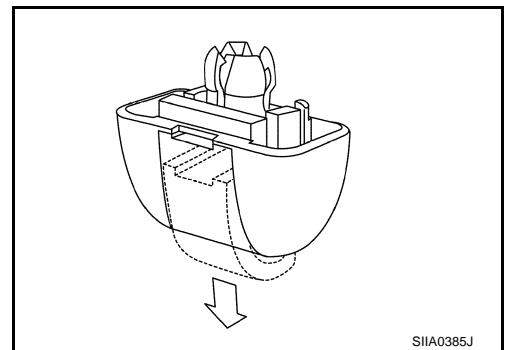

### Installation

Install in the reverse order of removal.

A  
B  
C  
D  
E  
F  
G  
H

EI

J  
K  
L  
M

# DOOR FINISHER

EIS000DK

## Disassembly and Assembly FRONT DOOR TRIM (DRIVER SIDE)

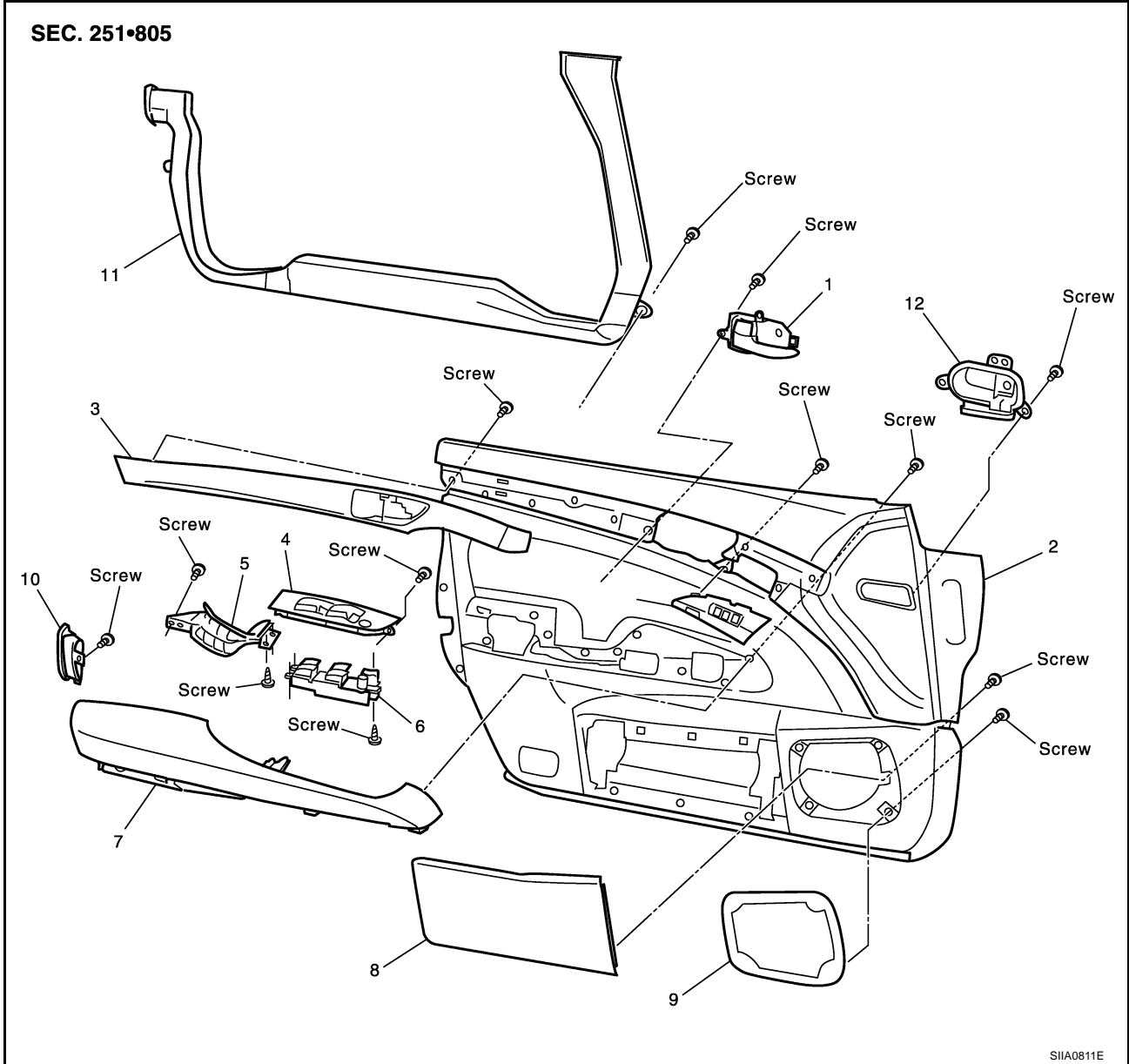

- |    |                                    |    |                     |    |                                |
|----|------------------------------------|----|---------------------|----|--------------------------------|
| 1  | Inside handle assembly             | 2  | Front door finisher | 3  | Front door waist finisher      |
| 4  | Front power window switch finisher | 5  | Pull handle         | 6  | Front power window switch unit |
| 7  | Front door upper arm-rest          | 8  | Front door pocket   | 9  | Front door speaker grille      |
| 10 | Ventilator B                       | 11 | Duct                | 12 | ventilator A                   |

# DOOR FINISHER

## FRONT DOOR TRIM (PASSENGER SIDE)

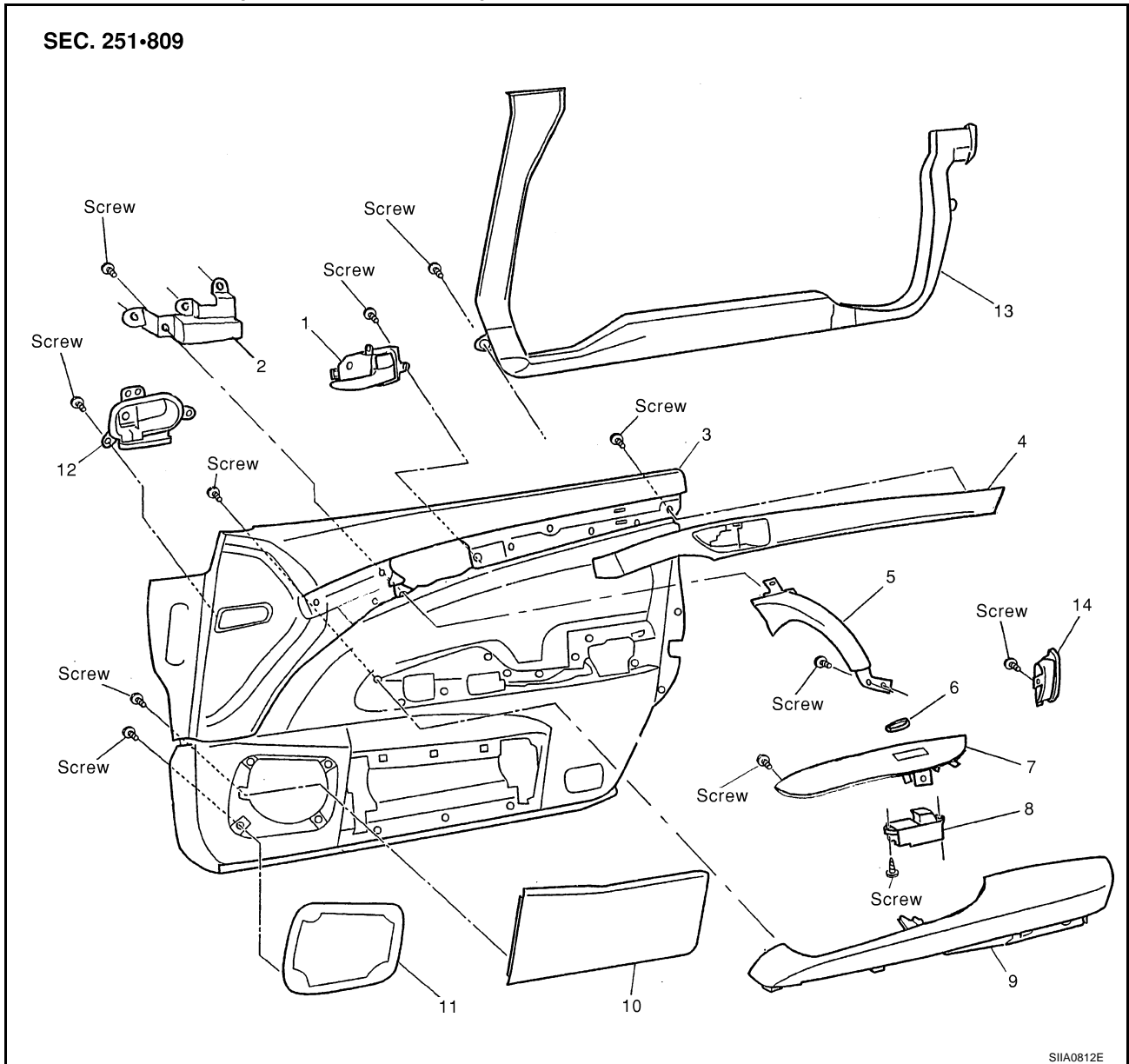

A  
B  
C  
D  
E  
F  
G  
H  
EI  
J  
K  
L  
M

- |                                      |                                  |                             |
|--------------------------------------|----------------------------------|-----------------------------|
| 1 Inside handle assembly             | 2 Front grip bracket             | 3 Front door finisher       |
| 4 Front door waist finisher          | 5 Front door grip                | 6 Grip escutcheon           |
| 7 Front power window switch finisher | 8 Front power window switch unit | 9 Front door upper arm-rest |
| 10 Front door pocket                 | 11 Front door speaker grille     | 12 ventilator A             |
| 13 Duct                              | 14 ventilator B                  |                             |

# DOOR FINISHER

## REAR DOOR TRIM

SEC. 251•825•828

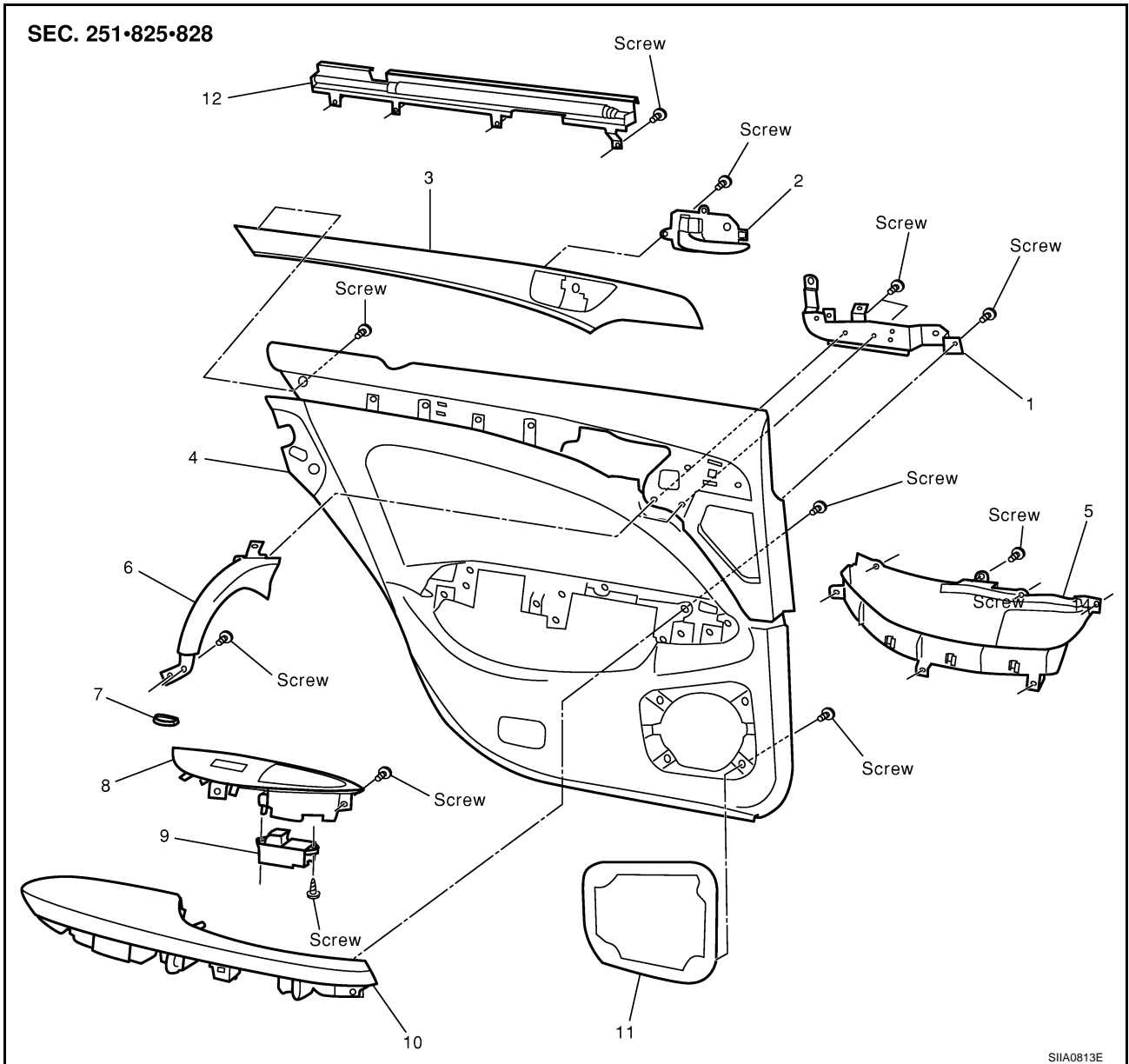

SIIA0813E

- |    |                          |    |                                   |    |                               |
|----|--------------------------|----|-----------------------------------|----|-------------------------------|
| 1  | Rear grip bracket        | 2  | Inside handle assembly            | 3  | Rear door waist finisher      |
| 4  | Rear door finisher       | 5  | Rear door pocket                  | 6  | Rear door grip                |
| 7  | Grip escutcheon          | 8  | Rear power window switch finisher | 9  | Rear power window switch unit |
| 10 | Rear door upper arm-rest | 11 | Rear door speaker grille          | 12 | Rear door sun-shade           |

# BODY SIDE TRIM

## BODY SIDE TRIM

PPF:76913

### Removal and Installation

E/S000DL

#### CAUTION:

- Wrap the tip of flat-bladed screwdriver with a cloth when removing metal clips from garnishes.
- When removing or installing body side welts, do not allow butyl seal to come in contact with pillar garnish.

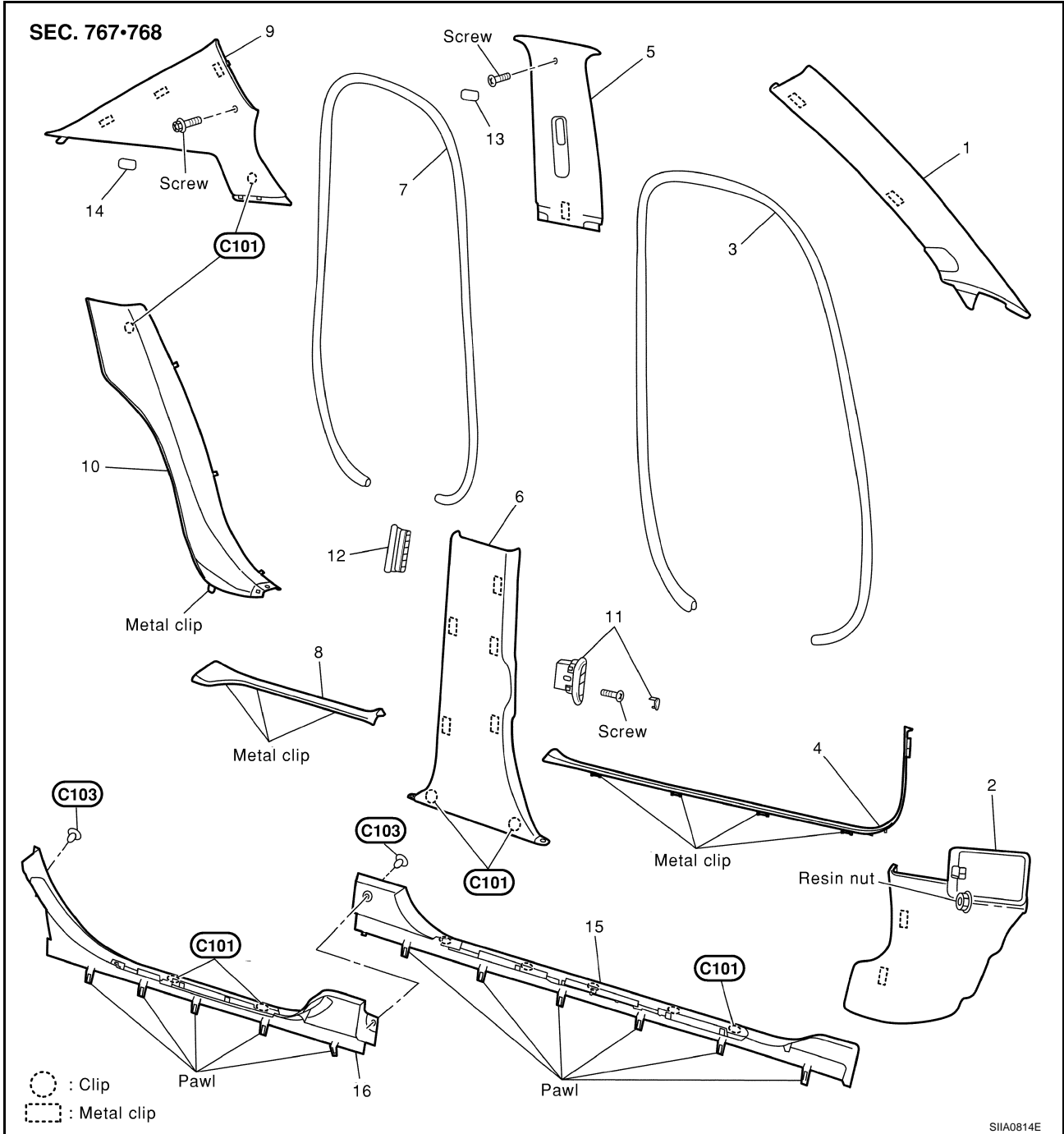

- |                              |                              |                                |
|------------------------------|------------------------------|--------------------------------|
| 1. Front pillar garnish      | 2. Dash side finisher        | 3. Front body side welt        |
| 4. Front kicking plate       | 5. Center pillar garnish     | 6. Center pillar lower garnish |
| 7. Rear body side welt       | 8. Rear kicking plate        | 9. Rear pillar finisher        |
| 10. Rear wheel house garnish | 11. Rear cooler inlet grille | 12. Rear cooler outlet grille  |
| 13. Center pillar upper cap  | 14. Rear pillar upper cap    | 15. Mudguard finisher (front)  |
| 16. Mudguard finisher (rear) |                              |                                |

A  
B  
C  
D  
E  
F  
G  
H  
EI  
J  
K  
L  
M

# BODY SIDE TRIM

## CENTER PILLAR LOWER GARNISH

### Removal

1. Remove front and rear kicking plate.
2. Remove rear cooler inlet grille

### Installation

Install in the reverse order of removal.

## CENTER PILLAR UPPER GARNISH

### Removal

1. Remove seat belt shoulder anchor. Refer to [SB-3, "Removal and Installation of Front Seat Belt"](#) .
2. Remove front and rear kicking plate.
3. Remove center pillar lower garnish.

### Installation

To install, reverse the removal procedure sequence.

## REAR PILLAR FINISHER

### Removal

1. Remove rear seat. Refer to [SE-197, "Removal and Installation"](#) .
2. Remove rear kicking plate.
3. Remove rear wheel house garnish.

### Installation

Install in the reverse order of removal.

## DASH SIDE FINISHER

### Removal

1. Remove front kicking plate.
2. Remove front body side welt.

### CAUTION:

Insert screw driver rolled with cloth between panel on vehicle and clips (as indicated with arrow), and disconnect clips.

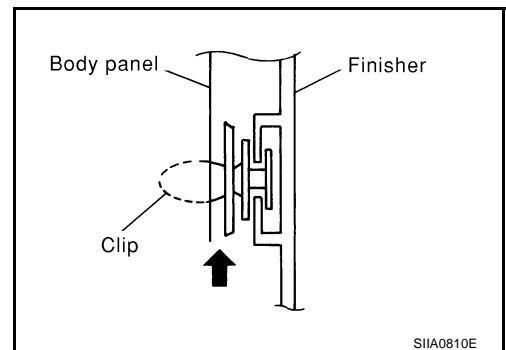

### Installation

Install in the reverse order of removal.

### CAUTION:

To install, check if all clips are matched over holes of panel on vehicle, then push on.

# REAR PARCEL SHELF FINISHER

## REAR PARCEL SHELF FINISHER

PFP:79910

### Removal and Installation

EIS000DM

A  
B  
C  
D  
E  
F  
G  
H  
EI  
J  
K  
L  
M

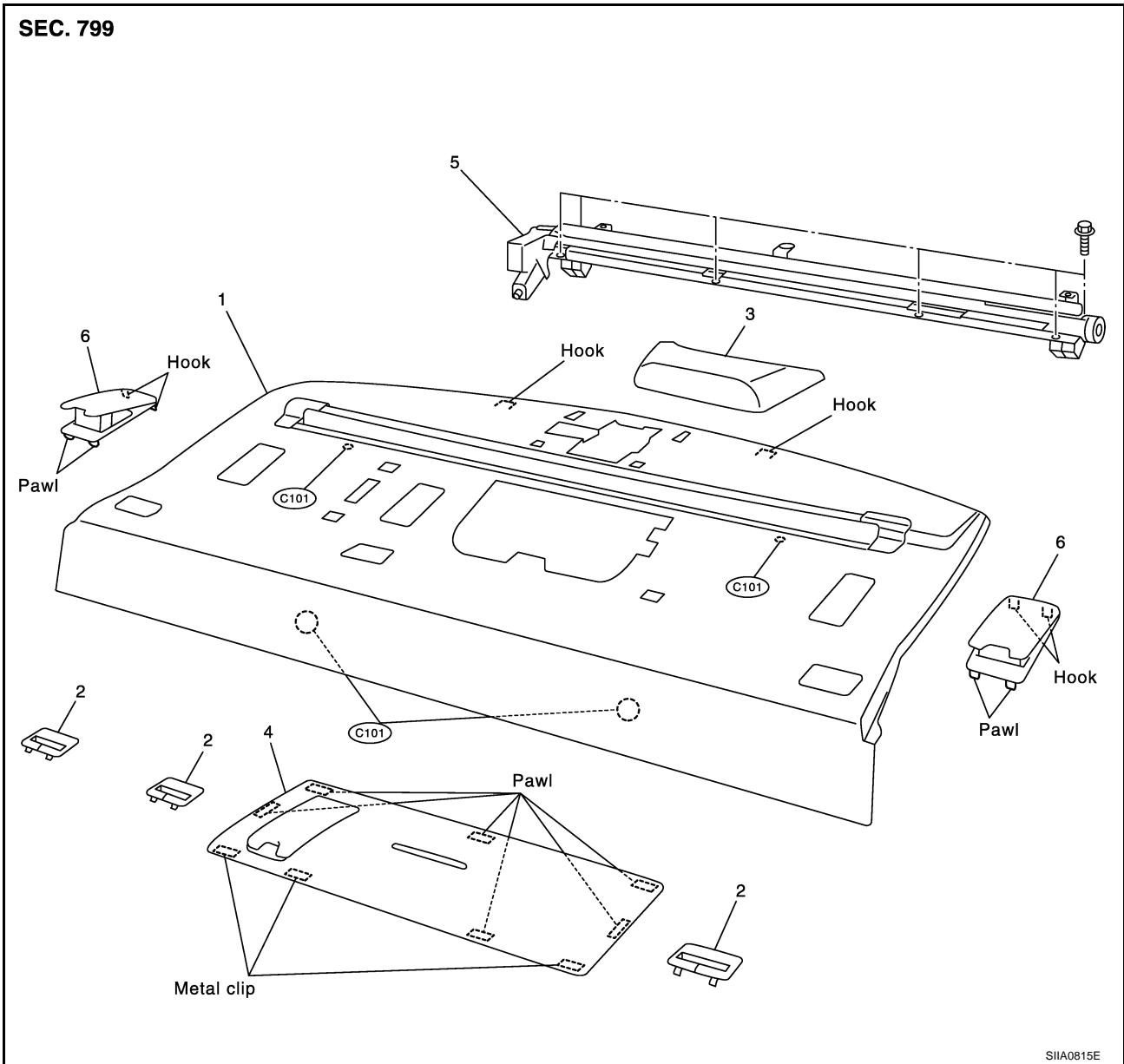

1. Rear parcel shelf finisher
2. Seat belt escutcheon
3. High mounted stop lamp
4. Woofer grille
5. Rear sunshade
6. Top tether strap child restraint cover

### REMOVAL

1. Remove rear seat. Refer to [SE-197, "Removal and Installation"](#).
2. Remove rear seat belt floor anchor bolts. Refer to [SB-4, "Removal and Installation of Rear Seat Belt"](#).
3. Remove rear pillar finisher. Refer to [EI-38, "REAR PILLAR FINISHER"](#).

## REAR PARCEL SHELF FINISHER

4. Remove high-mounted stop lamp, and disconnect connectors.

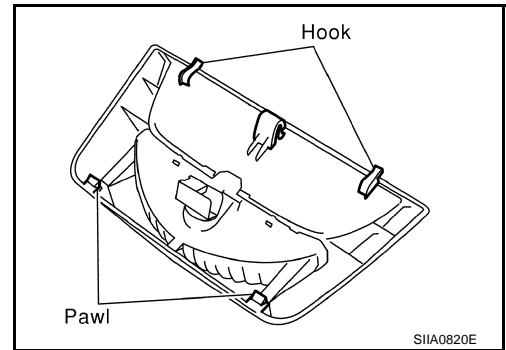

5. Remove woofer grille.
6. Remove seat belt escutcheon.

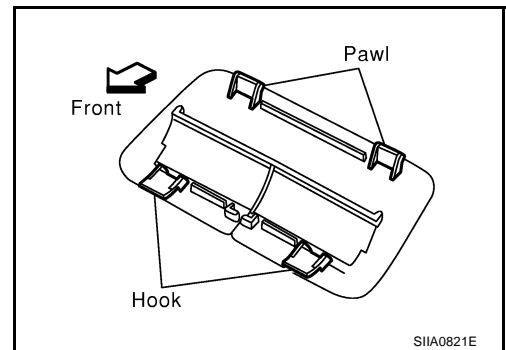

7. Remove clips, and remove rear parcel shelf finisher.
8. Disconnect rear sunshade connectors, remove screws, and remove rear sunshade.

### INSTALLATION

Install in the reverse order of removal.

#### CAUTION:

- Confirm hooks of rear parcel shelf finisher are completely inserted into holes on vehicle side.
- Confirm clips are matched over holes on vehicle side, then push on.



# SUNSHADE

## SUNSHADE

PPF:97580

### Component Parts and Harness Connector Location

EIS0014Q

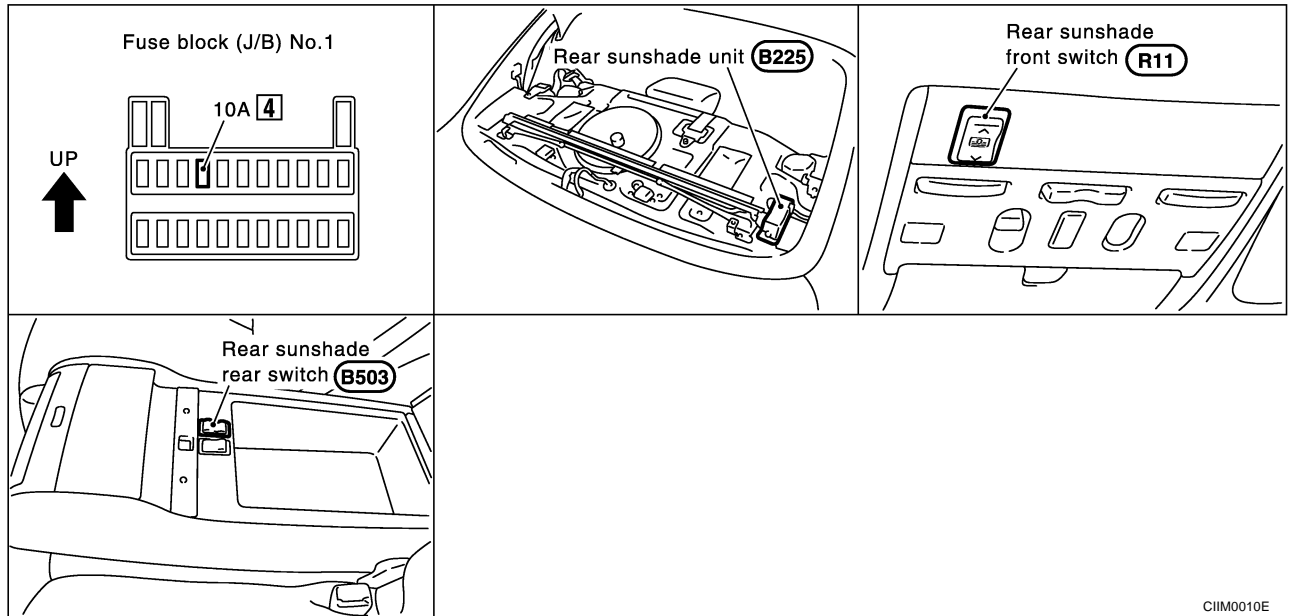

CIIM0010E

A  
B  
C  
D  
E  
F  
G  
H  
EI  
J  
K  
L  
M

EI

# SUNSHADE

## Schematic

EIS003NU

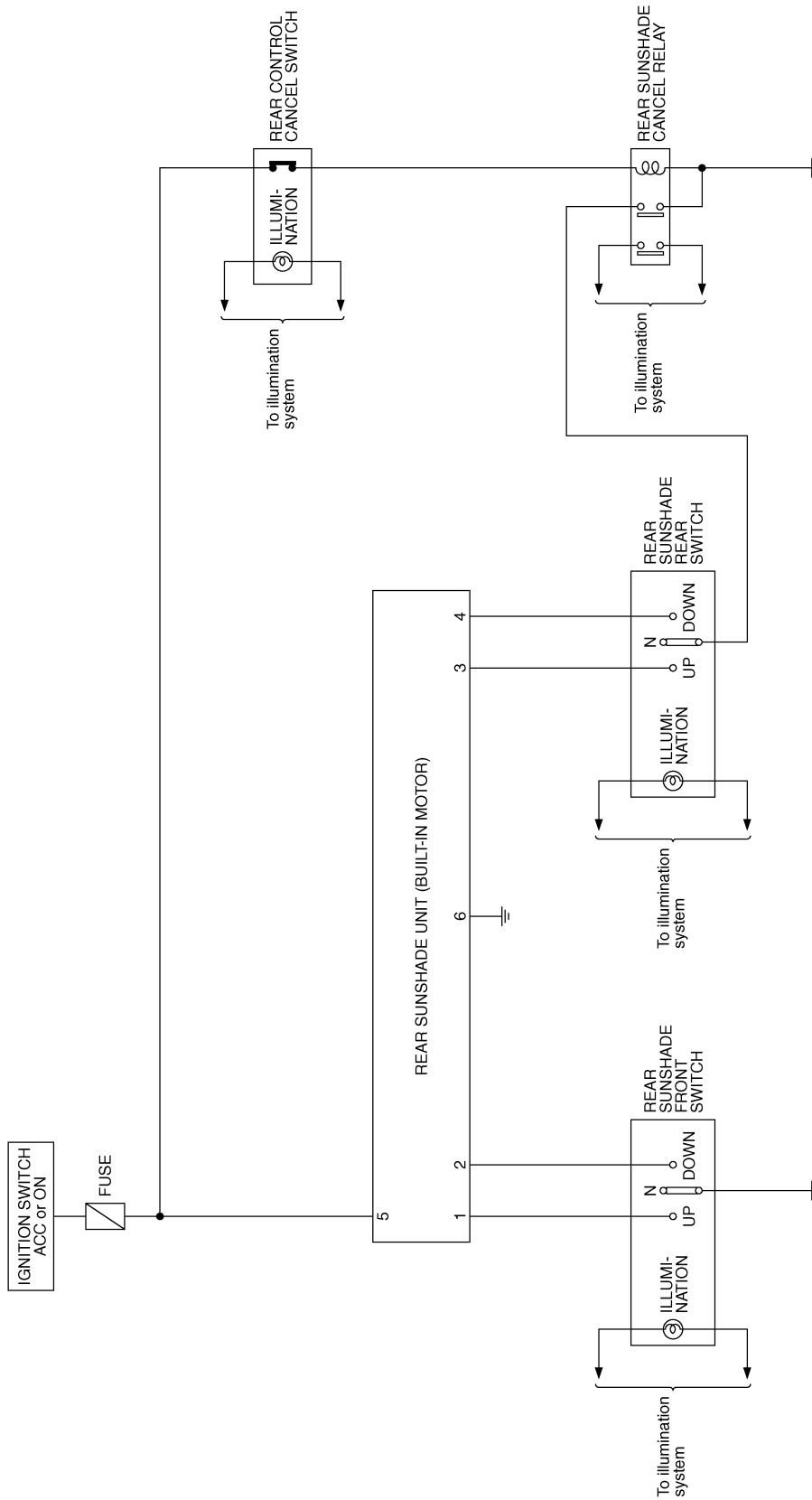

TIWM0149E

# SUNSHADE

## Wiring Diagram—SHADE—

EIS0014R

EI-SHADE-03

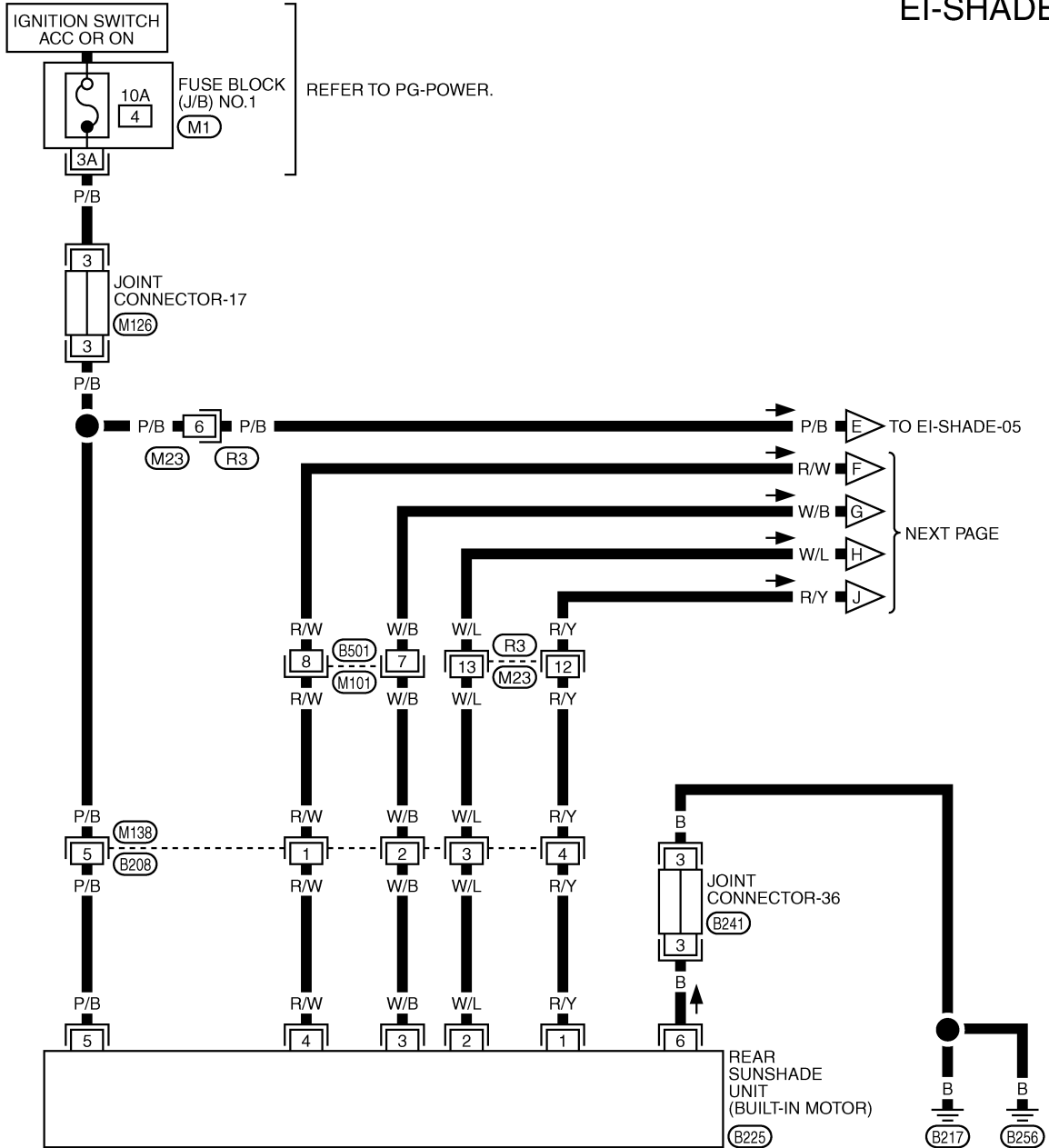

1	2	3	4	5	6	7	8	9	10	11		
12	13	14	15	16	17	18	19	20	21	22	23	24

(M101)  
W

(M138)  
BR

1	1	1	2	2	2	3	3	3	3
4	4	4	4	4	4	5	5	5	5

(M126)  
B

6	5		
4	3	2	1

(B225)  
W

1	1	1	1	2	2	2	2	2	2
3	3	3	3	3	3	3	3	3	3

(B241)  
P

1	2	3	4	5	6	7	8	9	10
11	12	13	14	15	16	17	18		

(R3)  
W

REFER TO THE FOLLOWING.

(M1) -FUSE BLOCK-JUNCTION BOX (J/B) NO.1

TIWM0150E

# SUNSHADE

EI-SHADE-04

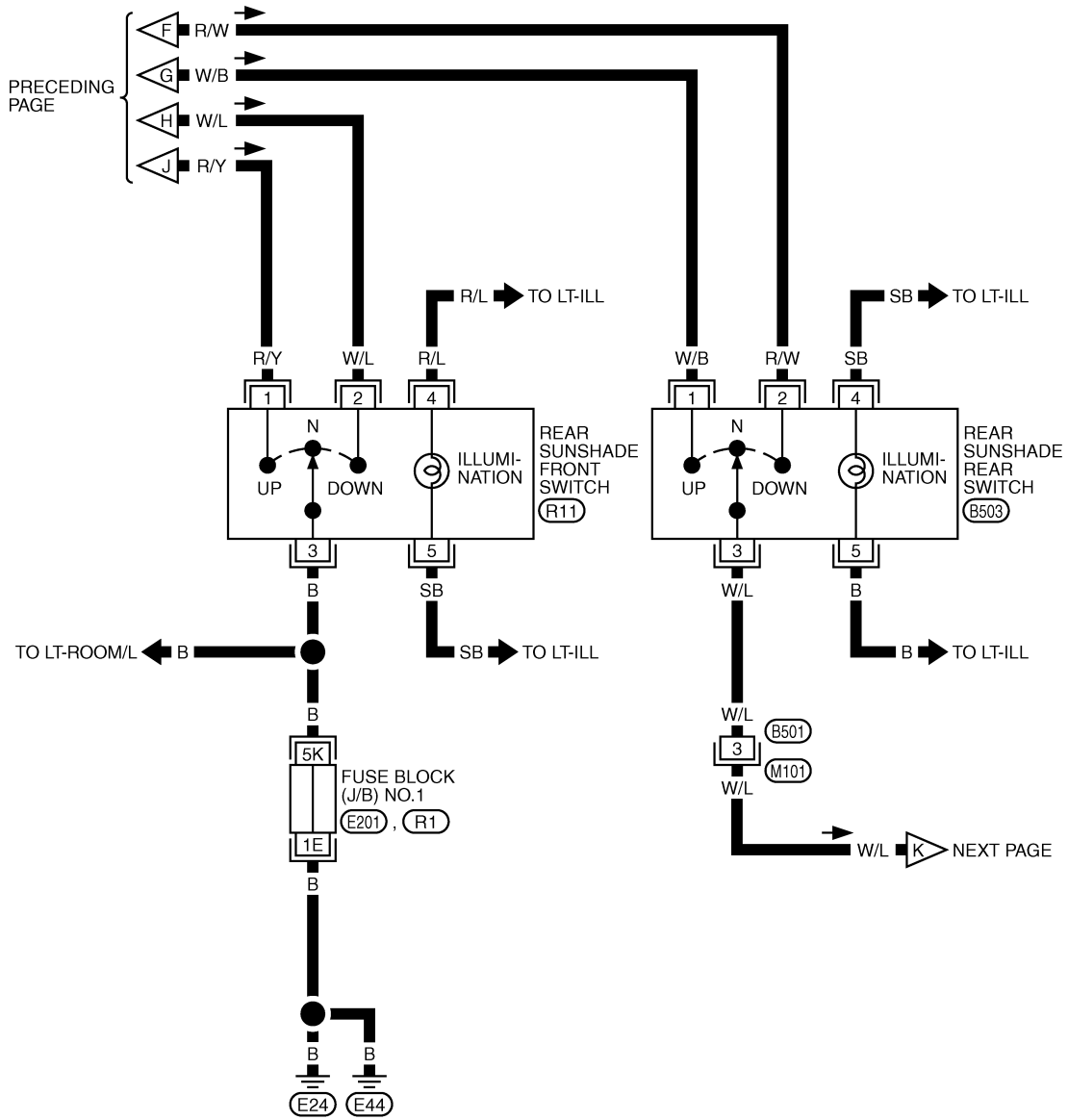

1	2	3	4	5	6	7	8	9	10	11		
12	13	14	15	16	17	18	19	20	21	22	23	24

(M101)  
W

5	3
4	2
1	1

(B503), (R11)  
W W

REFER TO THE FOLLOWING.  
(E201), (R1) - FUSE BLOCK-  
JUNCTION BOX (J/B) NO.1

TIWM0151E

# SUNSHADE

EI-SHADE-05

A  
B  
C  
D  
E  
F  
G  
H  
EI  
J  
K  
L  
M

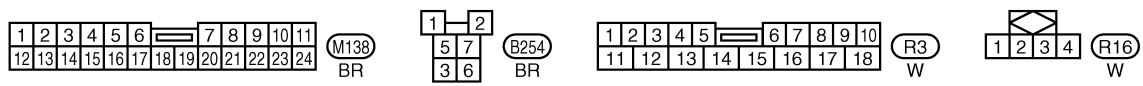
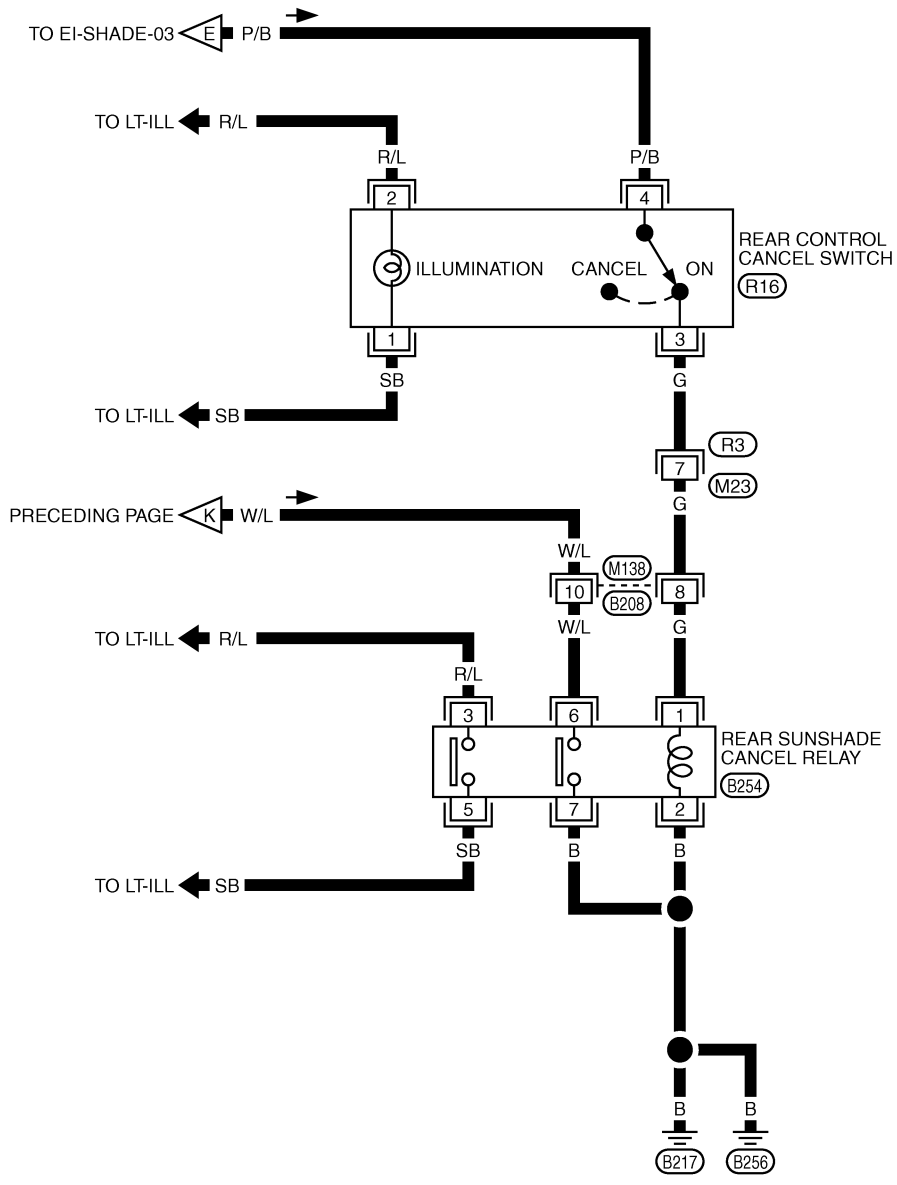

TIWM0152E

# SUNSHADE

## Terminals and Reference Value for Rear Sunshade Control Unit

EIS0014S

Terminal	Wire-color	Item	Condition		Voltage (V) (Approx.)
1	R/Y	Rear sunshade front switch UP signal	When rear sunshade front switch operates		5 → 0
2	W/L	Rear sunshade front switch DOWN signal	When rear sunshade front switch operates		5 → 0
3	W/B	Rear sunshade rear switch UP signal	When rear sunshade rear switch operates	Rear control cancel switch (OFF)*	5 → 0
				Rear control cancel switch (ON)*	5*
4	R/W	Rear sunshade rear switch DOWN signal	When rear sunshade rear switch operates	Rear control cancel switch (OFF)*	5 → 0
				Rear control cancel switch (ON)*	5*
5	P/B	ACC power supply	—		Battery voltage
6	B	Ground	—		0

\* Only the car with rear control cancel switch.

# FLOOR TRIM

## FLOOR TRIM

PF7:74902

### Removal and installation

EIS00072

A  
B  
C  
D  
E  
F  
G  
H

EI

J

K

L

M

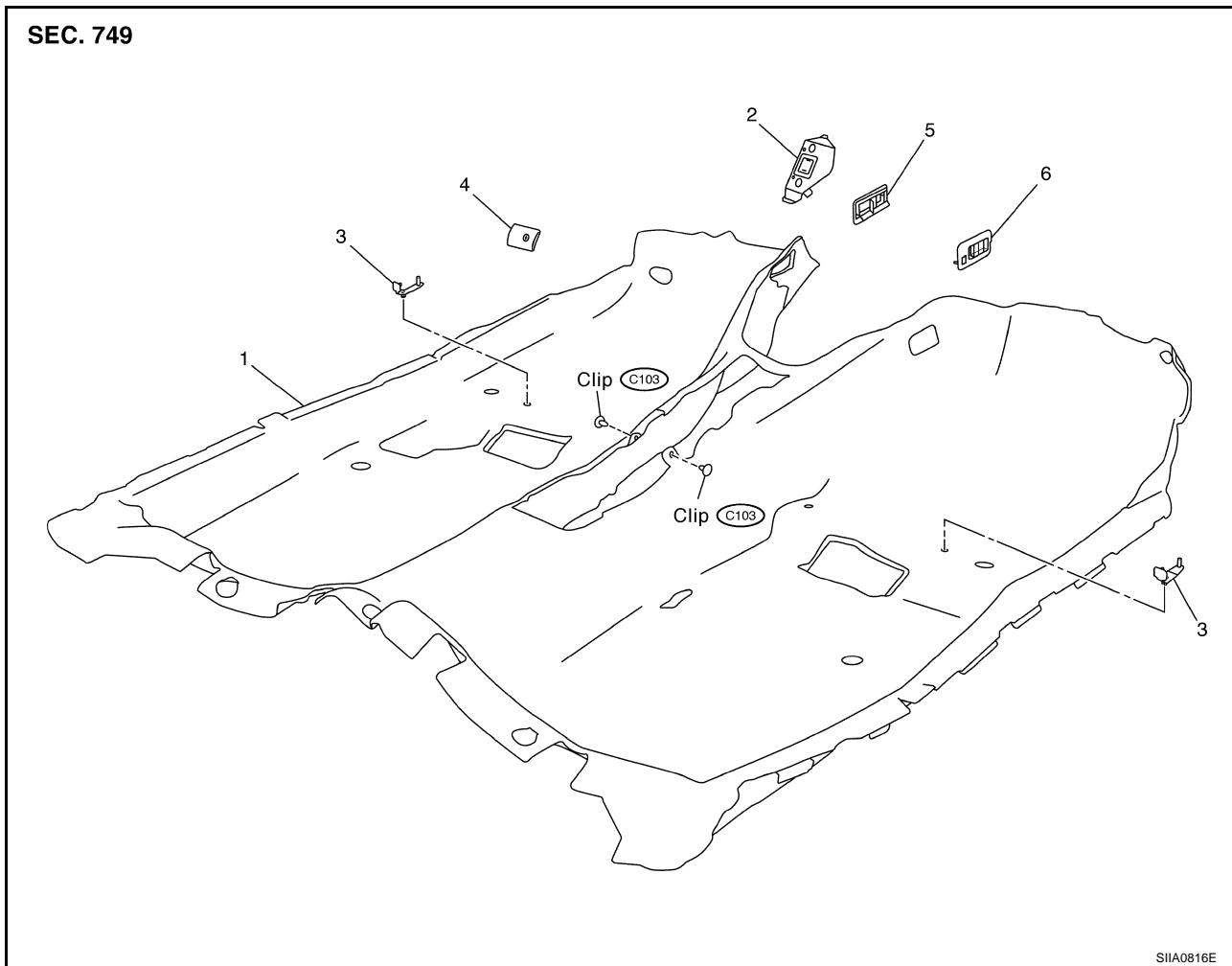

- |                              |                         |                          |
|------------------------------|-------------------------|--------------------------|
| 1. Floor carpet              | 2. Footrest             | 3. Carpet hook           |
| 4. Accelerator pedal stopper | 5. Heater nozzle (left) | 6. Heater nozzle (right) |

### REMOVAL

1. Remove front seat and rear seat cushions. Refer to [SE-188, "FRONT SEAT"](#) and [SE-197, "REAR SEAT"](#).
2. Remove center console and ashtray. Refer to [IP-14, "CONSOLE BOX ASSEMBLY"](#).
3. Remove front and rear kicking plate.
4. Remove front and rear body side welt.
5. Remove center pillar lower garnish.
6. Remove dash side finisher.

### NOTE:

For steps 3 to 6. Refer to [EI-37, "Removal and Installation"](#).

# FLOOR TRIM

7. Turn hexagon wrench in counterclockwise, and remove accelerator pedal stopper from stud bolts on vehicle.
  - To install, match holes of footrest over stud bolts on vehicle.

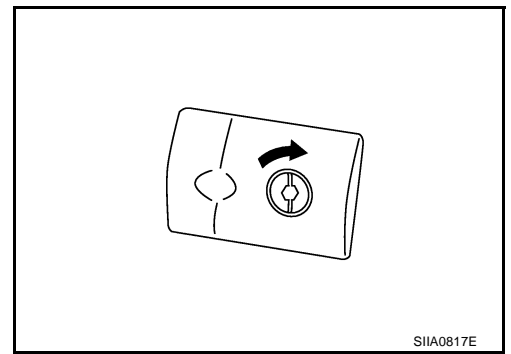

8. Remove heater nozzle.

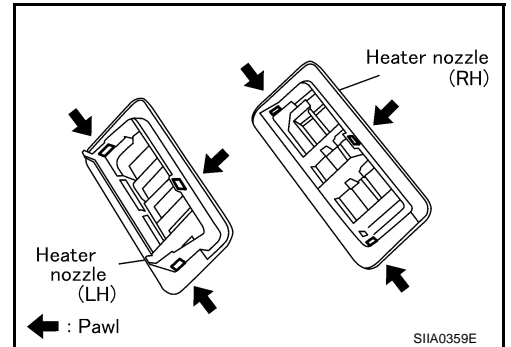

9. Cut front part of carpet, and pull to both side. Pull carpet to rear of vehicle, and remove.

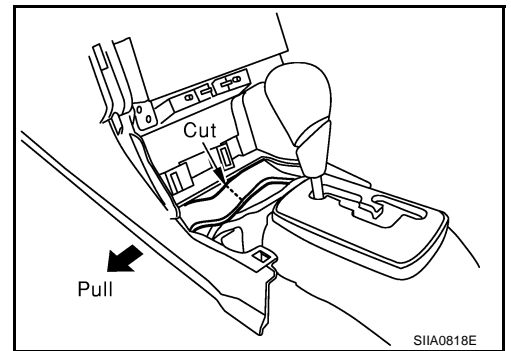

## INSTALLATION

Install in the reverse order of removal.

## FOOT-REST

### Removal

1. Turn up floor carpet on driver's seat.
2. Turn hexagon wrench to counterclockwise, and remove footrest from stud bolts on vehicle.

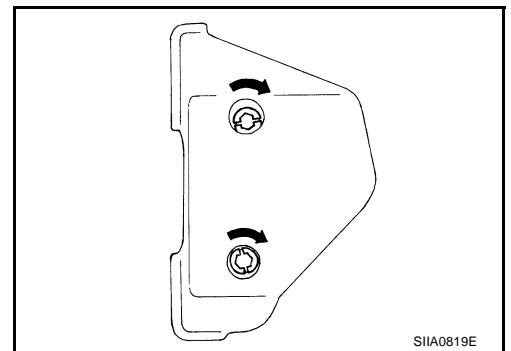

### Installation

Install in the reverse order of removal.



# HEADLINING

## HEADLINING

PPF:73910

### Removal and Installation

EIS000DO

A  
B  
C  
D  
E  
F  
G  
H  
EI  
J  
K  
L  
M

SEC. 264•738•963•964

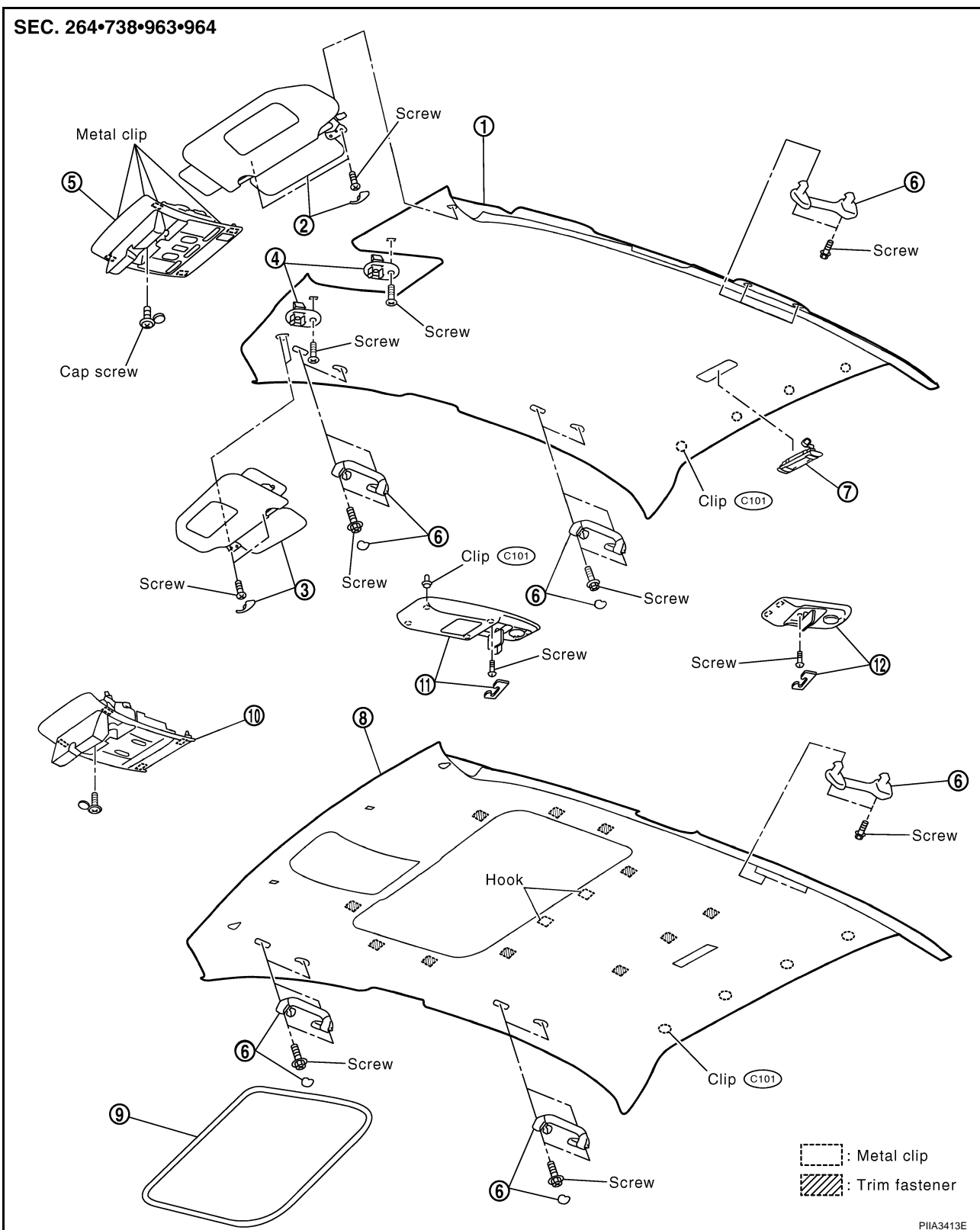

PIIA3413E

- |                          |                         |                     |
|--------------------------|-------------------------|---------------------|
| 1. Headlining (standard) | 2. Sunvisor (left)      | 3. Sunvisor (right) |
| 4. Holder retainer       | 5. Map lamp             | 6. Assist grip      |
| 7. Personal lamp         | 8. Headlining (sunroof) | 9. Sunroof welt     |

# HEADLINING

10. Map lamp & sunroof switch
13. Assist grip (sunroof/right rear seat)

11. Over head lamp console (VIP)

12. Over head console (STD)

## REMOVAL

1. Remove rear seat. Refer to [SE-197, "Removal and Installation"](#).
2. Remove body side welt. Refer to [EI-37, "BODY SIDE TRIM"](#).
3. Remove front pillar and center pillar garnish. Refer to [EI-37, "BODY SIDE TRIM"](#).
4. Remove assist grip.

### NOTE:

To remove assist grip of roof, insert small screw driver rolled with waste into dip on mask, pull it back to your side, remove it and remove screws (one each for left and right).

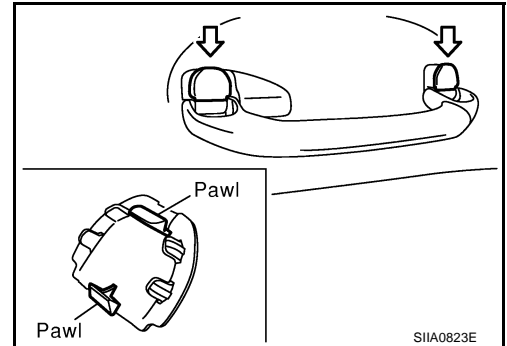

5. Remove map lamp, disconnect connector.
6. Remove personal lamp, disconnect connector.

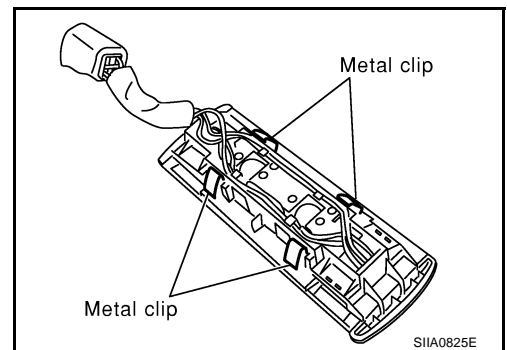

7. Remove sunvisor.
8. Remove sunroof welt. (Only Sunroof)
9. Disengage clips at rear of head lining, and remove trim fastener.
10. Remove holder retainer.
11. Slide front seat to the front, and set its seat back down backward.
12. Slide headlining forward of vehicle, and disconnect hooks (if equipped with sunroof).

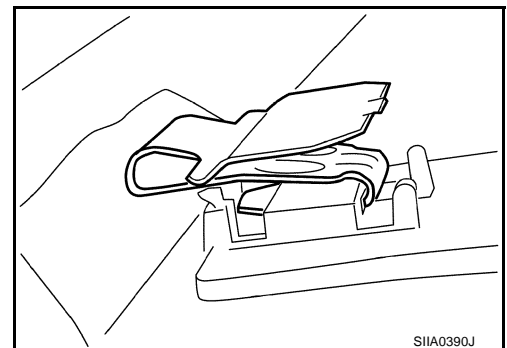

# HEADLINING

13. Remove headlining, turn and remove from left rear door.

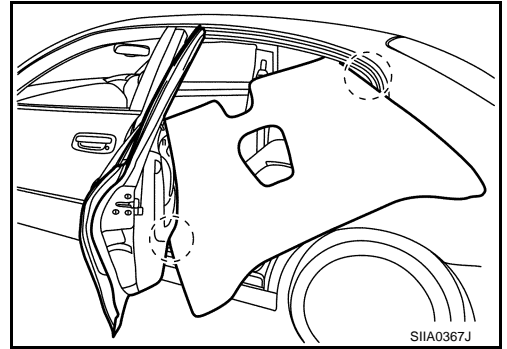

**CAUTION:**

- Always remove or install in a pair.
- Cover surroundings with waste to avoid scratches or damages.
- Do not bend head lining too hard.

**INSTALLATION**

Install in the reverse order of removal.

A  
B  
C  
D  
E  
F  
G  
H  
EI  
J  
K  
L  
M



# TRUNK ROOM TRIM & TRUNK LID FINISHER

PFP:84920

EIS000DU

## TRUNK ROOM TRIM & TRUNK LID FINISHER

### Removal and Installation

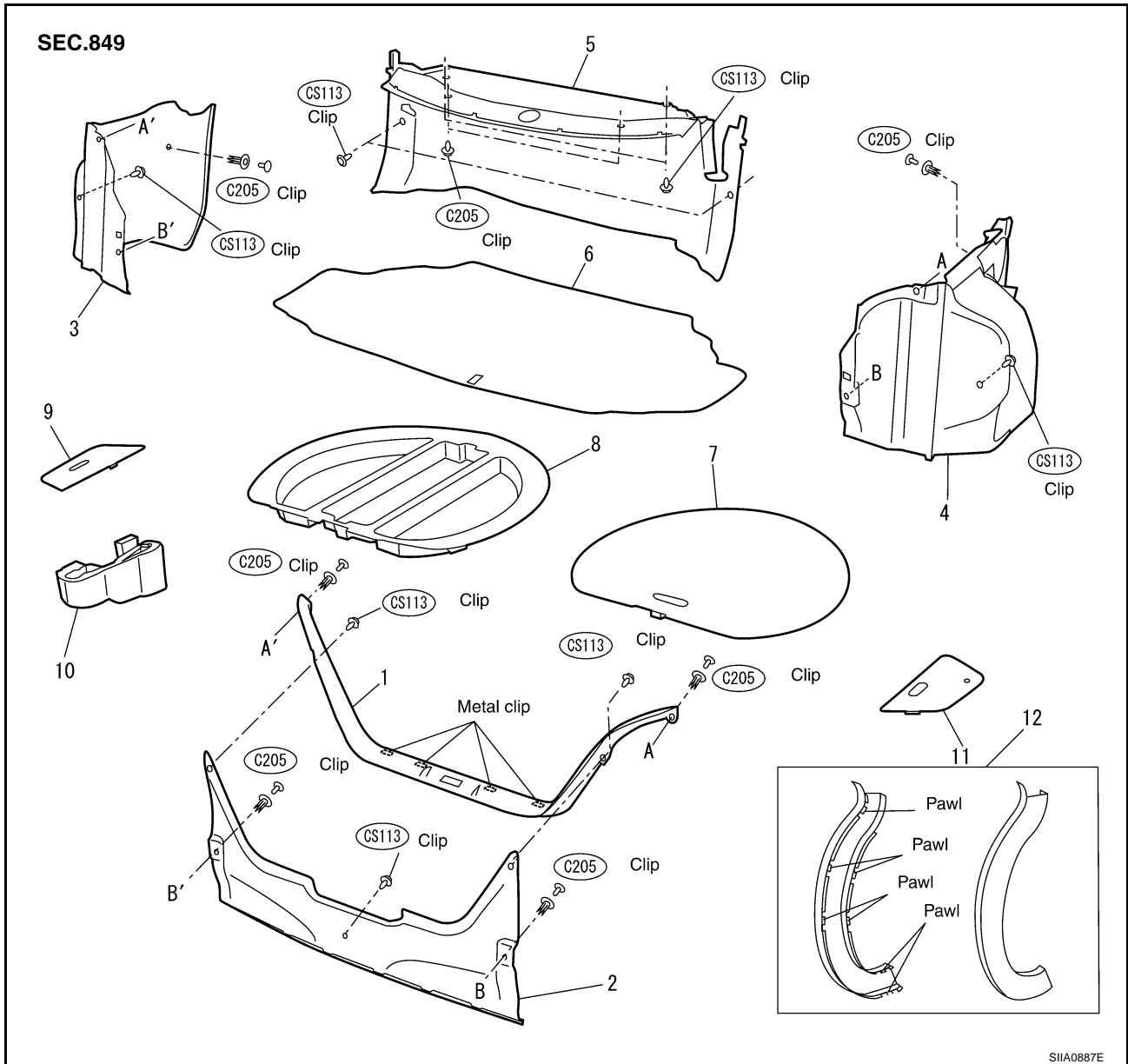

SIIA0887E

- |                                |                               |                               |
|--------------------------------|-------------------------------|-------------------------------|
| 1. Trunk rear plate            | 2. Trunk rear finisher        | 3. Trunk side finisher (left) |
| 4. Trunk side finisher (right) | 5. Trunk front finisher       | 6. Trunk floor carpet         |
| 7. Front spare tire cover      | 8. Spare tire cover           | 9. Trunk floor board (left)   |
| 10. Tool box                   | 11. Trunk floor board (right) | 12. Trunk hinge cover         |

## TRUNK ROOM TRIM

### Removal

1. Remove trunk floor carpet.
2. Remove front spare tire cover and spare tire cover.
3. Remove trunk floor board(left/right).
4. Remove clips of trunk rear plate and remove trunk rear plate.
5. Remove clips of trunk rear finisher and remove trunk rear finisher.
6. Remove clips of trunk front finisher and remove trunk front finisher.
7. Remove clips of trunk side finisher and remove trunk side finisher(left/right).
8. Remove trunk hinge cover.

# TRUNK ROOM TRIM & TRUNK LID FINISHER

## Installation

Install in the reverse order of removal.

## TRUNK LID FINISHER

### Removal

1. Remove clips(CS113) and bumper rubber then trunk lid finisher.
2. Remove trunk lid finisher.

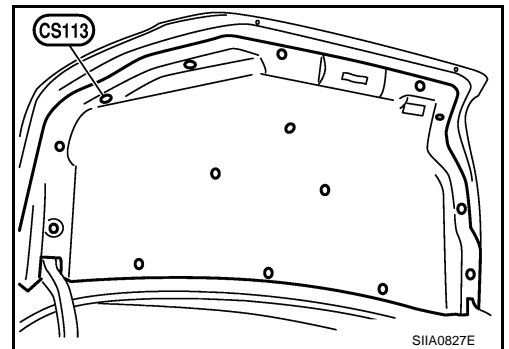

## Installation

Install in the reverse order of removal.

A  
B  
C  
D  
E  
F  
G  
H  
EI  
J  
K  
L  
M

# TRUNK ROOM TRIM & TRUNK LID FINISHER

---