

SECTION ACS

AUTO CRUISE CONTROL SYSTEM

CONTENTS

ASCD

PRECAUTIONS	3
Precautions for Supplemental Restraint System (SRS) "AIR BAG" and "SEAT BELT PRE-TENSIONER"	3
Wiring Diagrams and Trouble Diagnosis	3
AUTOMATIC SPEED CONTROL DEVICE (ASCD)....	4
Component Parts and Harness Connector Location...	4
System Description	4
POWER SUPPLY AND GROUND	4
OPERATION	5
ASCD PUMP OPERATION	6
Schematic	7
Wiring Diagram — ASCD —	8
FIG. 1	8
FIG. 2	9
FIG. 3	10
FIG. 4	11
FIG. 5	12
FIG. 6	13
Fail-Safe System	14
DESCRIPTION	14
MALFUNCTION DETECTION CONDITIONS	14
CONSULT-II Inspection Procedure	14
CONSULT-II Self-diagnostic Results	15
CONSULT-II Data Monitor	16
Trouble Diagnoses	17
SYMPTOM CHART	17
FAIL-SAFE SYSTEM CHECK	18
POWER SUPPLY AND GROUND CIRCUIT CHECK	19
ASCD BRAKE/STOP LAMP SWITCH CHECK...	20
ASCD STEERING SWITCH CHECK	22
VEHICLE SPEED SENSOR CHECK	23
ASCD PUMP CIRCUIT CHECK	24
ASCD ACTUATOR/PUMP CHECK	26
ECM SIGNAL CHECK	27
TCS MONITOR CHECK	28
Electrical Component Inspection	29

ASCD BRAKE SWITCH AND STOP LAMP SWITCH	29
PARK/NEUTRAL POSITION RELAY	29
ASCD Wire Adjustment	29
SERVICE DATA AND SPECIFICATIONS (SDS)	30
Standard and Limit	30
Tightening Torque	30

ICC

PRECAUTIONS	31
Precautions for Supplemental Restraint System (SRS) "AIR BAG" and "SEAT BELT PRE-TENSIONER"	31
Precautions for ICC System Service	31
Wiring Diagrams and Trouble Diagnosis	31
PREPARATION	32
Special Service Tools	32
DESCRIPTION	33
Outline	33
BRAKE ASSIST (WITH PREVIEW FUNCTION)..	33
System Diagram	33
Components Description	34
CAN Communication	34
CAN COMMUNICATION UNIT	34
Switch Operation	34
ICC System Display	35
ACTION TEST	36
ICC System Running Test	36
ICC SYSTEM SET CHECKING	36
CHECK FOR INCREASE OF THE CRUISING SPEED	36
CHECK FOR DECREASE OF THE CRUISING SPEED	36
CHECK FOR THE CANCELLATION OF ICC SYSTEM (NORMAL DRIVING CONDITION) IN THE FOLLOWING CASES:	36
CHECK FOR RESTORING THE SPEED THAT IS SET BY ICC SYSTEM BEFORE ICC CAN-	

CELLATION	36	DTC 63 RELEASE SW CIRCUIT	76
CHECK FOR ON/OFF SWITCH	36	DTC 65 PRESSURE CONTROL	77
CHECK FOR ACCEL/RES, COAST/SET, CANCEL SWITCHES	37	DTC 74 LASER BEAM OFF CNTR	78
CHECK FOR DISTANCE SWITCH	37	DTC 81 POWER SUPPLY VALVE	78
LASER BEAM AIMING ADJUSTMENT	38	DTC 83 POWER SUPPLY VALVE	79
Outline	38	DTC 85 AIR VALVE [LOW VOLTAGE]	80
Preparation	38	DTC 87 RELEASE VALVE [LOW VOLTAGE]	80
Outline of Adjustment Procedure	38	DTC 90 STOP LAMP RLY FIX	81
Setting the ICC Target Board	38	DTC 92 ECM CIRCUIT	86
ADJUSTING HEIGHT OF THE TARGET	38	DTC 97 AT CIRCUIT	86
ADJUSTING THE RIGHT-LEFT POSITION OF THE TARGET	39	DTC 98 GEAR POSITION	86
SETTING THE TARGET	39	DTC 102 RADAR STAIN	87
Aiming Adjustment	40	DTC 103 LASER SENSOR FAIL	88
CHECK AFTER THE ADJUSTMENT	43	DTC 104 LASER AIMING INCOMP	88
ELECTRICAL UNITS LOCATION	44	DTC 107 LASER COMM FAIL	88
Component Parts and Harness Connector Location	44	DTC 109 LASER HIGH TEMP	89
WIRING DIAGRAM	45	TROUBLE DIAGNOSIS FOR SYMPTOMS	90
Schematic	45	Symptom Chart	90
Wiring Diagram — ICC —	46	Symptom 1: Cruise ON/OFF Does Not Switch ON. (The ICC System Display in the Combination Meter Does Not Illuminate.) Cruise ON/OFF Does Not Switch OFF. (The ICC System Display in the Combination Meter Remains Powered.)	91
TERMINALS AND REFERENCE VALUE	53	Symptom 2: The ICC System Cannot Be Set (ON/OFF Switch Turns on/Off).	93
Terminals and Reference Value for ICC Unit	53	Symptom 3: The ICC System Cannot Be Cancelled by the CANCEL Switch, RESUME or Increase the Set Vehicle Speed, or Change the Distance Setting... ..	94
Terminals and Reference Value for ICC Sensor	55	Symptom 4: The ICC System Is Not Cancelled When the Gear Is in Other Than 'D'.	95
Terminals and Reference Value for ICC Warning Chime	55	Symptom 5: Chime Does Not Sound.	95
TROUBLE DIAGNOSIS — GENERAL DESCRIPTION	56	Symptom 6: Chime Does Not Stop.	97
Work Flow	56	Symptom 7: Driving Force Is Hunting.	97
CONSULT-II Function	57	Symptom 8: The ICC System Frequently Cannot Detect the Vehicle Ahead/The Detection Zone Is Short.	97
DESCRIPTION	57	Symptom 9: The System Does Not Detect the Vehicle Ahead at All.	98
WORK SUPPORT	57	ELECTRICAL COMPONENT INSPECTION	99
SELF-DIAGNOSTIC RESULTS	58	ICC Steering Switch	99
DATA MONITOR	58	ICC Brake Switch and Stop Lamp Switch	99
ACTIVE TEST	60	Booster Solenoid	99
Self-Diagnostic Function	61	Release Switch	100
WITH CONSULT-II	61	ASCD Actuator	100
WITHOUT CONSULT-II	62	Vacuum Hose	100
SELF-DIAGNOSIS BY CONSULT-II WILL NOT RUN	63	ASCD Pump	100
SELF-DIAGNOSIS BY ICC SYSTEM DISPLAY WILL NOT RUN.	64	REMOVAL AND INSTALLATION	102
TROUBLE DIAGNOSIS FOR SELF-DIAGNOSTIC ITEMS	66	ICC Unit	102
Diagnostic Trouble Code (DTC) Chart	66	ICC Sensor	102
DTC 11 CONTROL UNIT	68	ICC Warning Chime	103
DTC 20 CAN COMM CIRCUIT	68	ICC Steering Switch	103
DTC 31 POWER SUPPLY CIR 1, DTC 34 POWER SUPPLY CIR 2	68	ASCD Wire Adjustment	104
DTC 41 VHCL SPEED SE CIRC	69	SERVICE DATA AND SPECIFICATIONS (SDS) ...	105
DTC 42 THRTL POS SEN CIRC	69	Standard and Limit	105
DTC 43 ABS/TCS/VDC CIRC	71	Tightening Torque	105
DTC 45 BRAKE SW/STOP L SW	71		
DTC 46 OPERATION SW CIRC	73		
DTC 61 PRESS SEN CIRCUIT	75		
DTC 62 BOOSTER SOL/V CIRCUIT	75		

PRECAUTIONS

PF0:00001

Precautions for Supplemental Restraint System (SRS) “AIR BAG” and “SEAT BELT PRE-TENSIONER”

EKS006S7

The Supplemental Restraint System such as “AIR BAG” and “SEAT BELT PRE-TENSIONER”, used along with a front seat belt, helps to reduce the risk or severity of injury to the driver and front passenger for certain types of collision. This system includes seat belt switch inputs and dual stage front air bag modules. The SRS system uses the seat belt switches to determine the front air bag deployment, and may only deploy one front air bag, depending on the severity of a collision and whether the front occupants are belted or unbelted. Information necessary to service the system safely is included in the SRS and SB section of this Service Manual.

WARNING:

- To avoid rendering the SRS inoperative, which could increase the risk of personal injury or death in the event of a collision which would result in air bag inflation, all maintenance must be performed by an authorized NISSAN/INFINITI dealer.
- Improper maintenance, including incorrect removal and installation of the SRS, can lead to personal injury caused by unintentional activation of the system. For removal of Spiral Cable and Air Bag Module, see the SRS section.
- Do not use electrical test equipment on any circuit related to the SRS unless instructed to in this Service Manual. SRS wiring harnesses can be identified by yellow and/or orange harnesses or harness connectors.

Wiring Diagrams and Trouble Diagnosis

EKS005Q9

When you read wiring diagrams, refer to the followings:

- Refer to [GI-14, "How to Read Wiring Diagrams"](#) in GI section
- Refer to [PG-2, "POWER SUPPLY ROUTING"](#) for power distribution circuit in PG section

When you perform trouble diagnosis, refer to the followings:

- Refer to [GI-10, "HOW TO FOLLOW TEST GROUPS IN TROUBLE DIAGNOSES"](#) in GI section
- Refer to [GI-26, "How to Perform Efficient Diagnosis for an Electrical Incident"](#) in GI section

A

B

C

D

E

F

G

H

I

J

ACS

L

M

AUTOMATIC SPEED CONTROL DEVICE (ASCD)

PFP:18930

Component Parts and Harness Connector Location

EKS00307

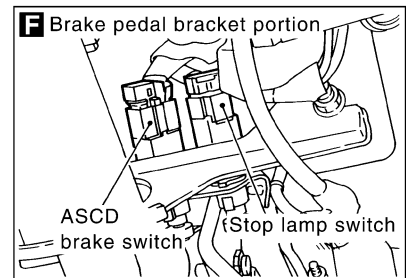
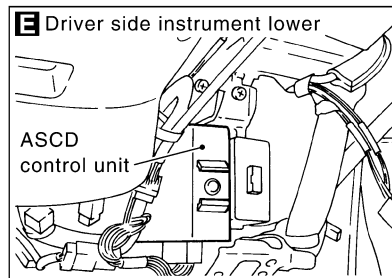
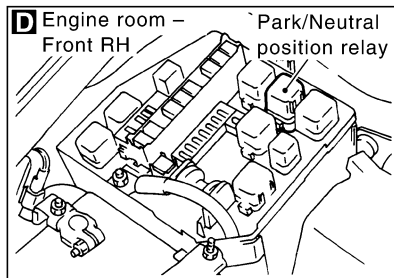
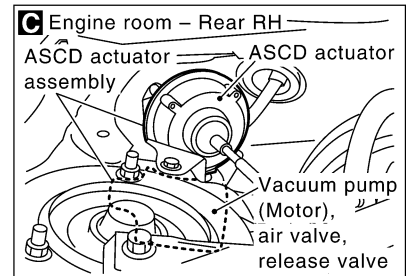
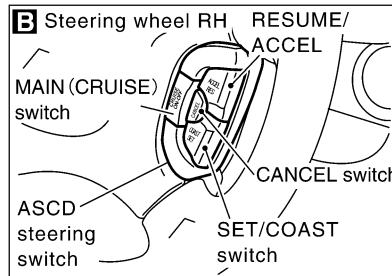
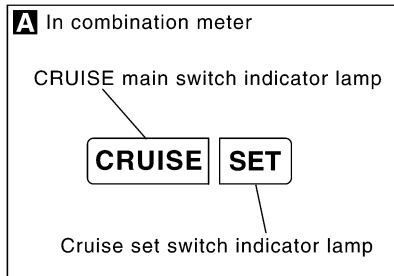
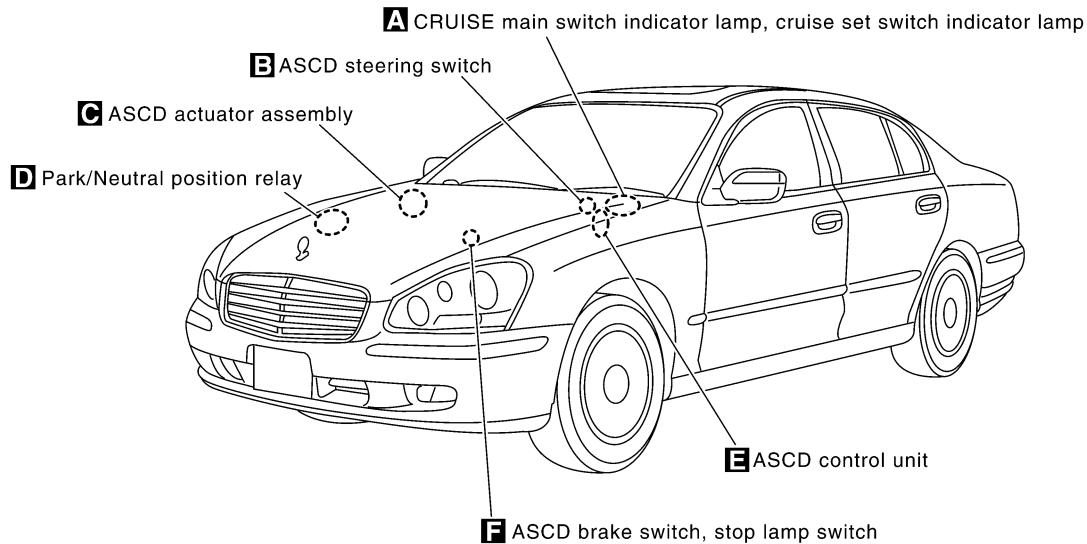

PKIA2625E

System Description

EKS00308

Refer to Owner's Manual for ASCD operating instructions.

POWER SUPPLY AND GROUND

When ignition switch is in the ON or START position power is supplied:

- through 10A fuse [No. 12, located in the fuse block (J/B) NO.1]
- to ASCD control unit terminal 5 and
- through ASCD brake switch terminal 1 and 2
- to park/neutral position relay terminal 3.
- through 10A fuse [No. 9, located in the fuse block (J/B) NO.1]

- to combination meter terminal 59

Power is supplied at all times:

- through 15A fuse [No. 17, located in the fuse block (J/B) NO.1]
- to the stop lamp switch terminal 1.

When park/neutral position is in the P or N position, ground is supplied:

- to park/neutral position relay terminal 2
- through body grounds E24 and E44.

When MAIN (CRUISE) switch is depressed (ON), ground is supplied:

- to ASCD steering switch terminal 1
- from ASCD control unit terminal 11.
- to ASCD control unit terminal 24
- from ASCD steering switch terminal 2.

then ASCD control unit holds CRUISE condition and illuminates CRUISE indicator.

Ground is supplied:

- to combination meter terminal 63
- from ASCD control unit terminal 15.

OPERATION

Set Operation

To activate the ASCD, all of following conditions must exist.

- Power supply to ASCD control unit terminal 8. [Brake pedal is released and A/T selector lever is in a position other than P or N.]
- Vehicle speed is between 40 km/h (25 MPH) and 144 km/h (89 MPH). (Signal from combination meter)

When the SET/COAST switch is depressed, power is supplied:

- from ASCD control unit terminal 11.
- to ASCD steering switch terminal 1.

And then ASCD pump is activated to control throttle wire and ASCD control unit supply ground

- to combination meter terminals 64 to illuminate SET indicator.

A/T Overdrive Control during Cruise Control Driving

When the vehicle speed is approximately 3 km/h (2 MPH) below set speed, a signal is sent

- from ASCD control unit terminal 10
- to TCM (transmission control module) through combination meter.

When this occurs, the TCM (transmission control module) cancels overdrive.

After vehicle speed is approximately 1 km/h (0.6 MPH) above set speed, overdrive is reactivated.

ASCD Shifting Control

During ASCD cruise, ASCD control unit controls A/T shifting to avoid uncomfortable shifting.

This is used to control the signals below.

- Throttle position sensor from ECM
- A/T shift solenoid valve A

Coast Operation

When the SET/COAST switch is depressed during cruise control driving, ASCD actuator returns the throttle cable to decrease vehicle set speed until the switch is released. And then ASCD will keep the new set speed.

Accel Operation

When the RESUME/ACCEL switch is depressed, power is supplied

- from ASCD control unit terminal 11
- to ASCD steering switch terminal 1.

If the RESUME/ACCEL switch is depressed during cruise control driving, ASCD actuator pulls the throttle cable to increase the vehicle speed until the switch is released or vehicle speed reaches the maximum speed controlled by the system. ASCD will then keep the new set speed.

A
B
C
D
E
F
G
H
I
J

ACS

L
M

Cancel Operation

When any of following conditions exist, cruise operation will be canceled.

- CANCEL switch is depressed. (Power supply to ASCD control unit terminal 11)
- Brake pedal is depressed. (Power supply to ASCD control unit terminal 23 from stop lamp switch)
- Brake pedal is depressed or A/T selector lever is shifted to P or N position. (Power supply to ASCD control unit terminal 8 is interrupted.)

If MAIN (CRUISE) switch is turned to OFF during ASCD activation, all ASCD operations will be canceled and vehicle speed memory will be erased.

Resume Operation

When the RESUME/ACCEL switch is depressed after cancel operation other than when depressing MAIN (CRUISE) switch is performed, vehicle speed will return to last set speed. To resume vehicle set speed, vehicle condition must meet following conditions.

- Brake pedal is released.
- A/T selector lever is in other than P and N position.
- Vehicle speed is greater than 40 km/h (25 MPH) and less than 144 km/h (89 MPH).

ASCD PUMP OPERATION

The ASCD pump consists of a vacuum motor, an air valve and a release valve. When the ASCD activates, power is supplied

- from ASCD control unit terminal 12
- to ASCD pump terminal 1.

Ground is supplied to vacuum motor, air valve and release valve from ASCD control unit depending on the operated condition as shown in the below table.

The pump is connected to ASCD actuator by vacuum hose. When the ASCD pump is activated, the ASCD pump vacuum affects the diaphragm of ASCD actuator to control throttle cable.

		Air valve (*1)	Release valve (*1)	Vacuum motor	Actuator inner pressure
ASCD not operating		Open	Open	Stopped	Atmosphere
ASCD operating	Releasing throttle cable	Open	Closed	Stopped	Vacuum
	Holding throttle position	Closed	Closed	Stopped	Vacuum (*2)
	Pulling throttle cable	Closed	Closed	Operated	Vacuum

*1: When power and ground is supplied, valve is closed.

*2: Set position held.

AUTOMATIC SPEED CONTROL DEVICE (ASCD)

[ASCD]

Schematic

EKS00309

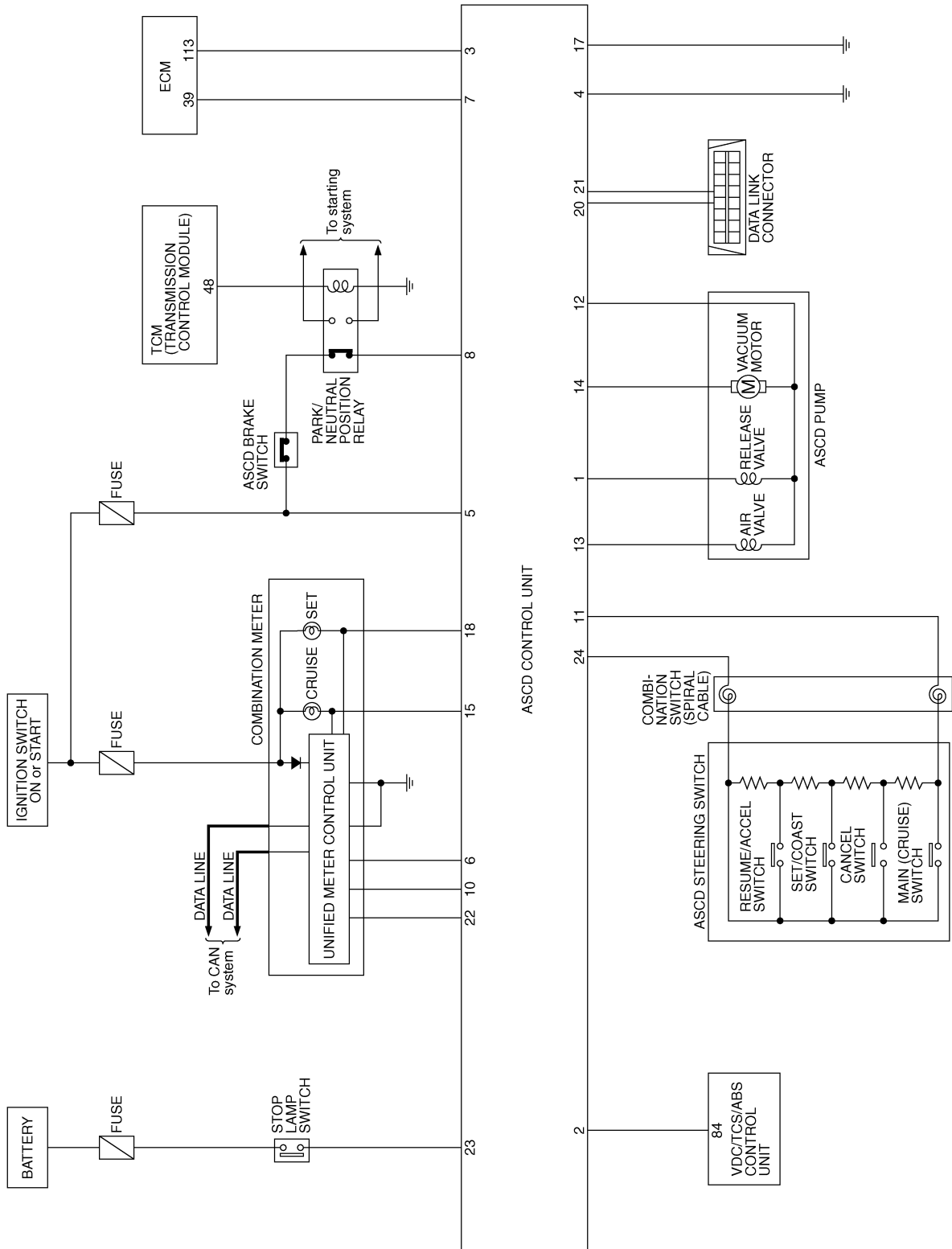

A
B
C
D
E
F
G
H
I
J
L
M

ACS

AUTOMATIC SPEED CONTROL DEVICE (ASCD)

[ASCD]

EKS0030A

Wiring Diagram — ASCD —
FIG. 1

ACS-ASCD-01

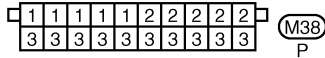
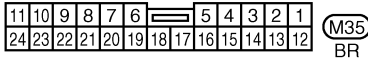
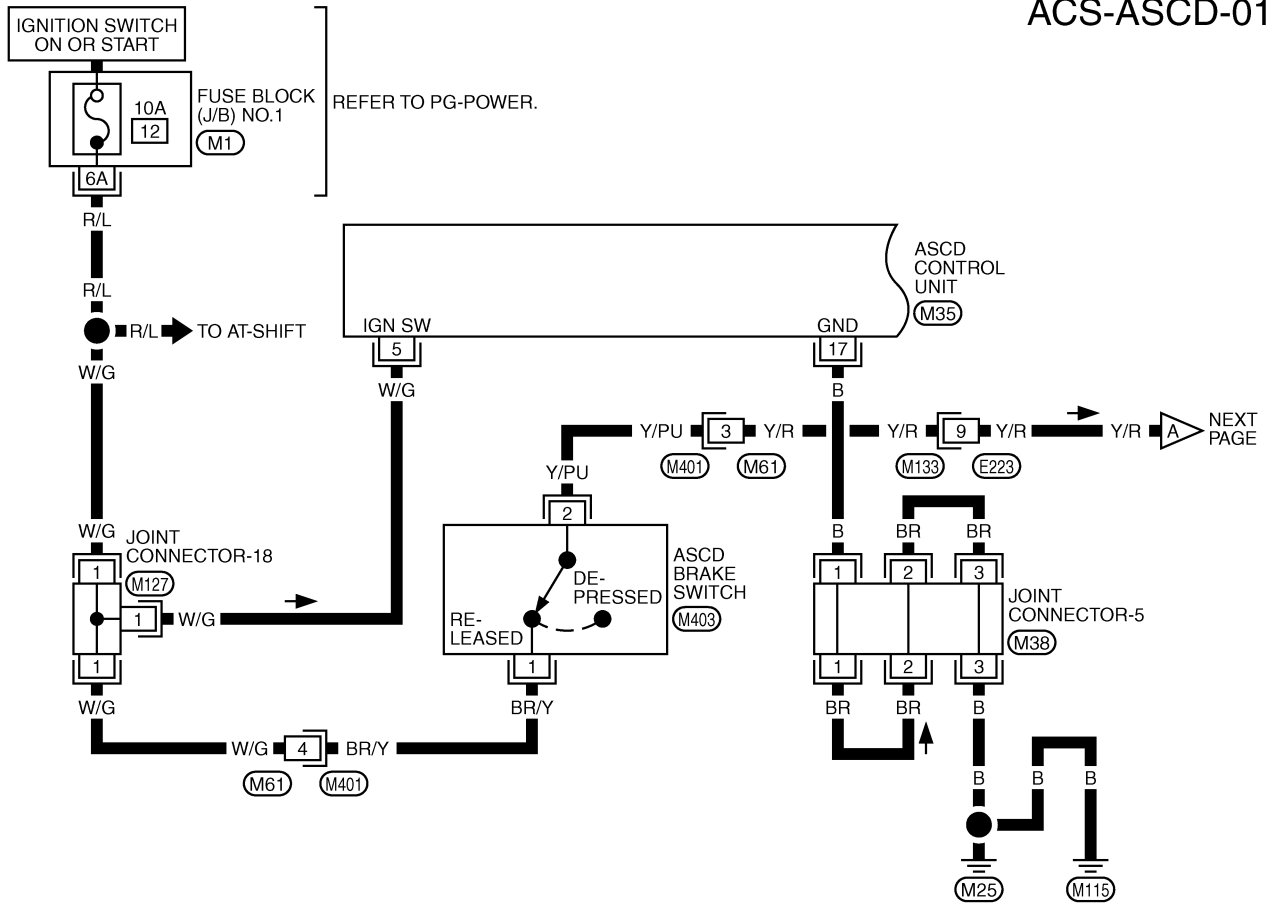

REFER TO THE FOLLOWING.

(M1) - FUSE BLOCK-JUNCTION BOX (J/B) NO.1

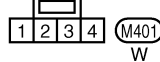
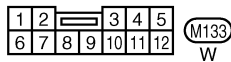
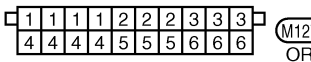

TKWM0441E

FIG. 2

ACS-ASCD-02

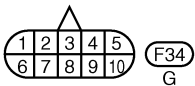
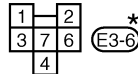
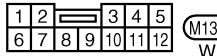
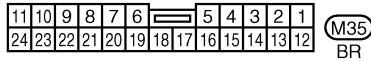
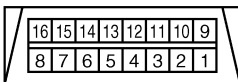
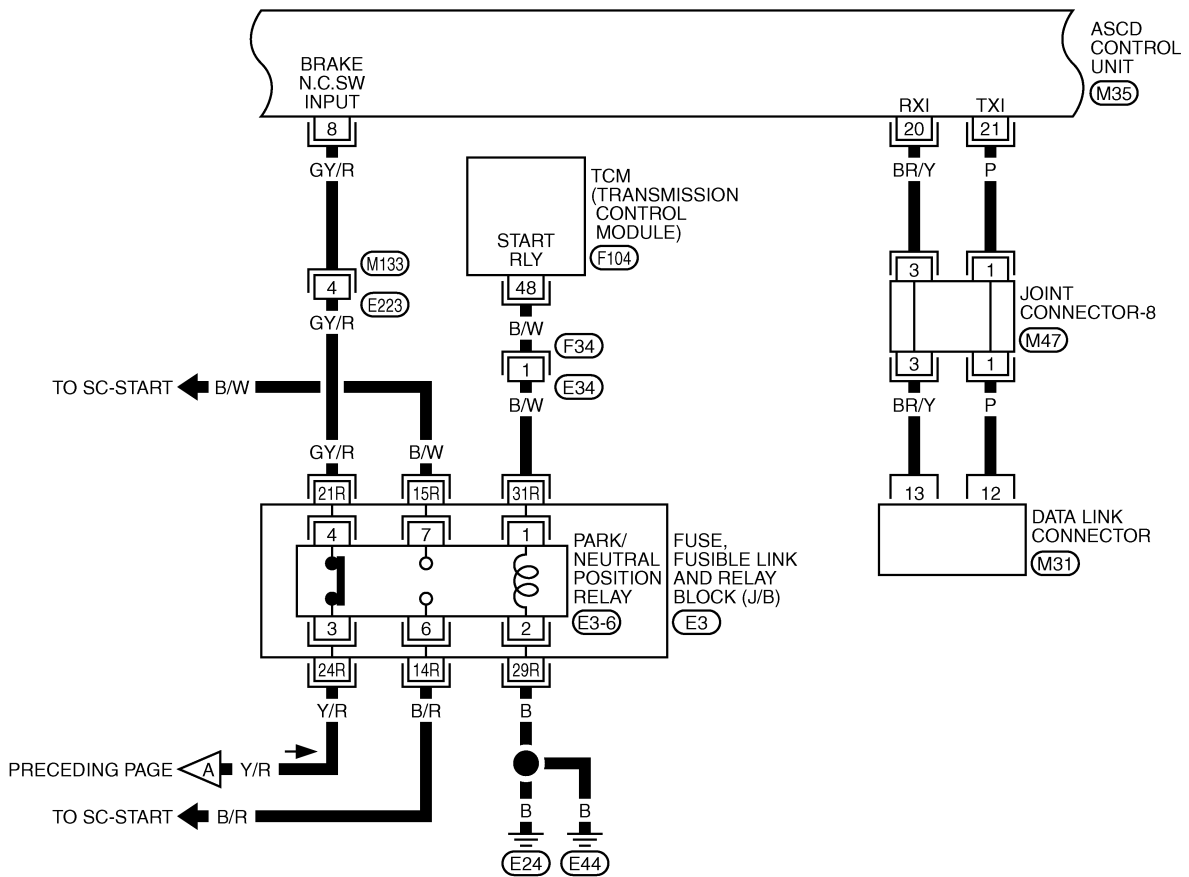

*: THIS CONNECTOR IS NOT SHOWN IN "HARNESS LAYOUT", PG SECTION.

REFER TO THE FOLLOWING.

(E3) - FUSE, FUSIBLE LINK AND RELAY BLOCK (J/B)

(F104) - ELECTRICAL UNITS

A
B
C
D
E
F
G
H
I
J
L
M

ACS

FIG. 3

ACS-ASCD-03

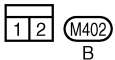
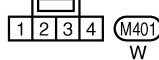
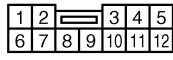
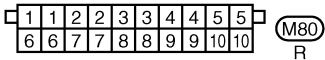
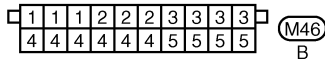
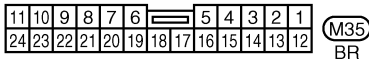
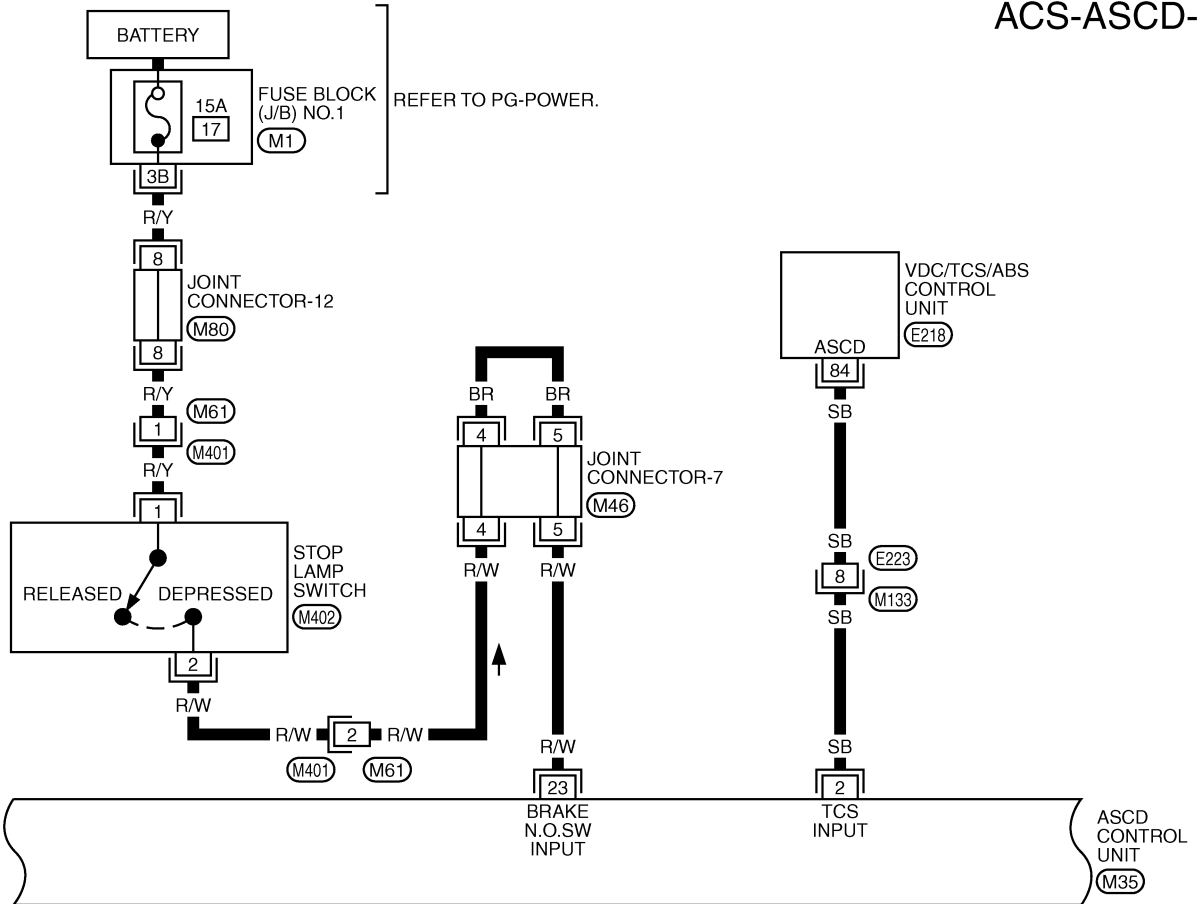

REFER TO THE FOLLOWING.

(M1) - FUSE BLOCK-JUNCTION BOX (J/B) NO.1

(E218) - ELECTRICAL UNITS

AUTOMATIC SPEED CONTROL DEVICE (ASCD)

[ASCD]

FIG. 4

ACS-ASCD-04

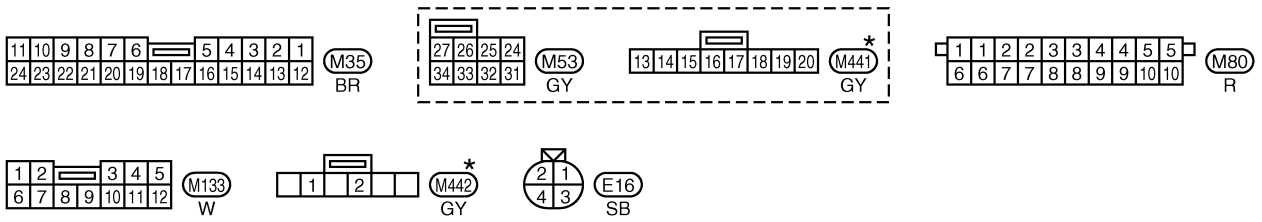
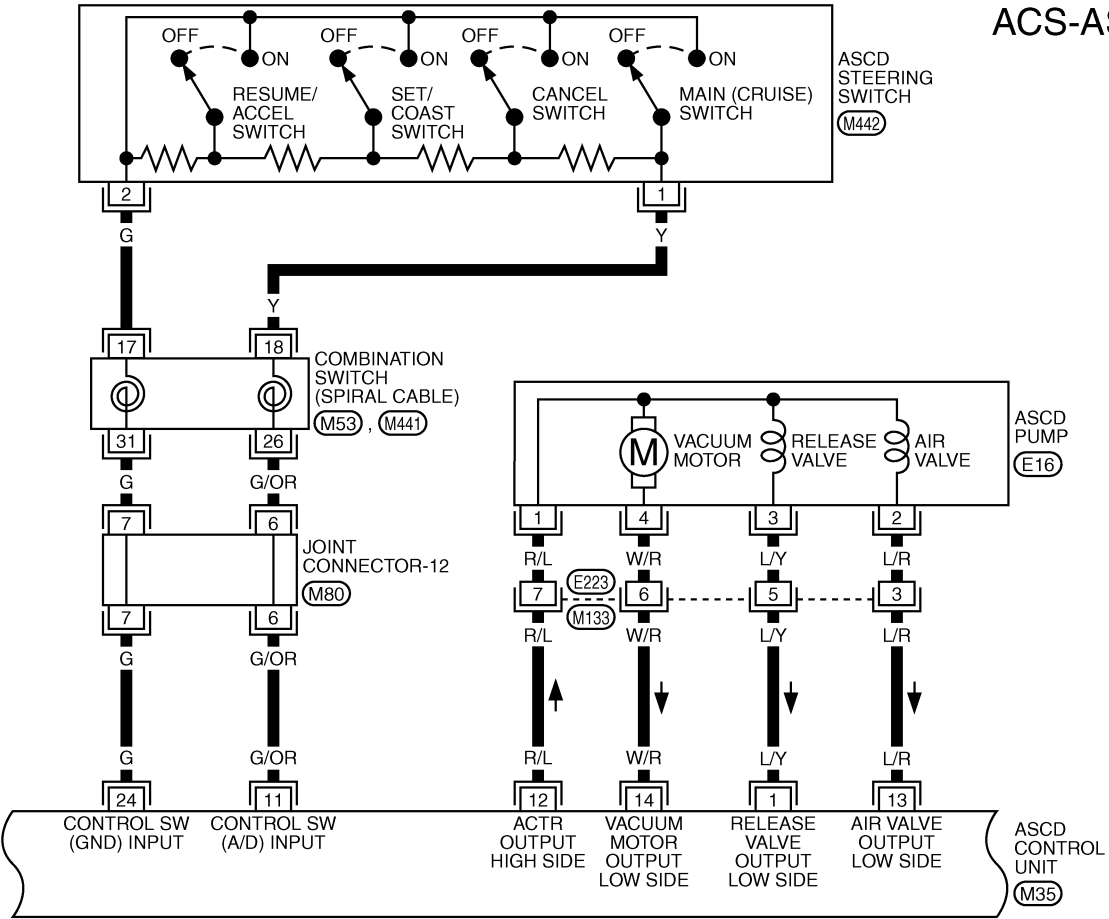

*: THIS CONNECTOR IS NOT SHOWN IN "HARNESS LAYOUT", PG SECTION.

TBWM0063E

AUTOMATIC SPEED CONTROL DEVICE (ASCD)

[ASCD]

FIG. 5

ACS-ASCD-05

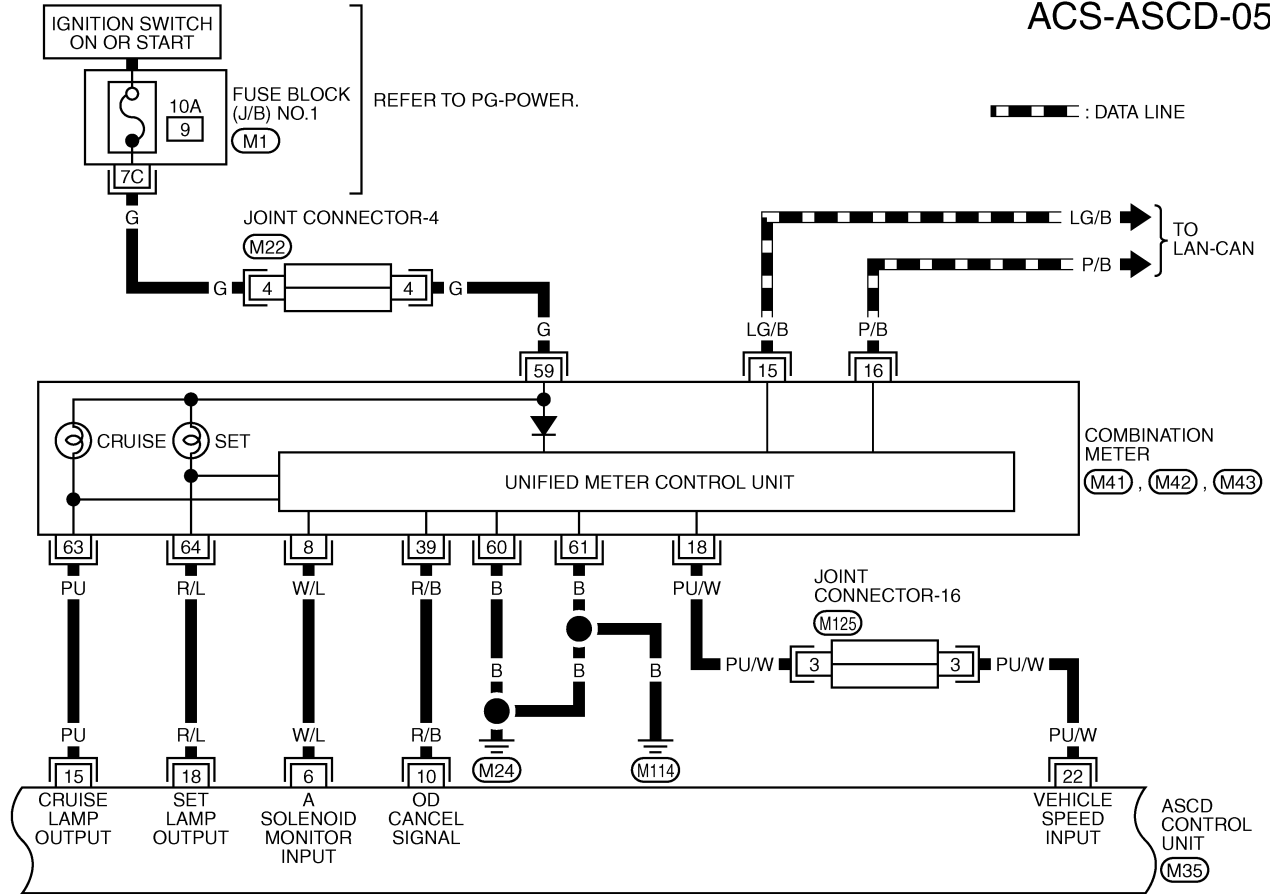

1	1	1	1	1	2	2	2	2
3	3	3	3	3	4	4	4	4

(M22)
L

11	10	9	8	7	6	5	4	3	2	1		
24	23	22	21	20	19	18	17	16	15	14	13	12

(M35)
BR

REFER TO THE FOLLOWING.
(M1) - FUSE BLOCK-JUNCTION BOX (J/B) NO.1

1	2	3	4	5	6	7	8	9		
10	11	12	13	14	15	16	17	18	19	20

(M41)
BR

21	22	23	24	25	26	27	28	29	30	31		
32	33	34	35	36	37	38	39	40	41	42	43	44

(M42)
BR

45	46	47	48	49	50	51	52	53	54	55		
56	57	58	59	60	61	62	63	64	65	66	67	68

(M43)
W

1	1	1	2	2	3	3	3	3
4	4	4	4	4	5	5	5	5

(M125)
B

TKWM0443E

FIG. 6

ACS-ASCD-06

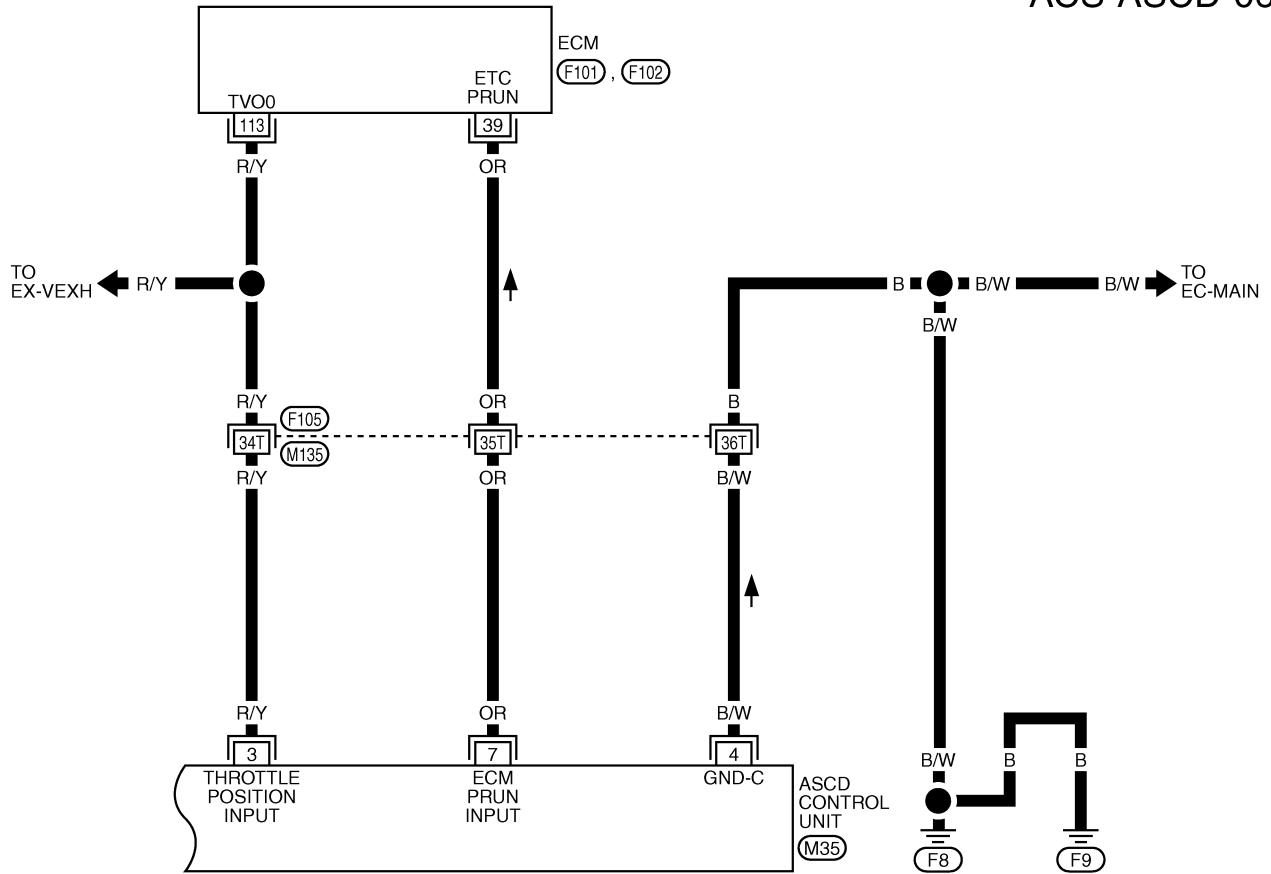

11	10	9	8	7	6	5	4	3	2	1		
24	23	22	21	20	19	18	17	16	15	14	13	12

(M35)
BR

REFER TO THE FOLLOWING.

- (F105) -SUPER MULTIPLE JUNCTION (SMJ)
- (F101), (F102) -ELECTRICAL UNITS

A
B
C
D
E
F
G
H
I
J

ACS

L
M

Fail-Safe System DESCRIPTION

When the fail-safe system senses a malfunction, it deactivates ASCD operation. The SET indicator in the combination meter will then flash.

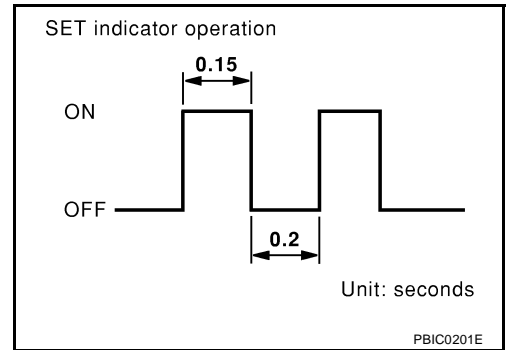

MALFUNCTION DETECTION CONDITIONS

Detection conditions	ASCD operation during malfunction detection
<ul style="list-style-type: none"> ● ASCD steering (RESUME/ACCEL, CANCEL, SET/COAST) switch is stuck. ● Vacuum motor ground circuit or power circuit is open or shorted. ● Air valve ground circuit or power circuit is open or shorted. ● Release valve ground circuit or power circuit is open or shorted. ● Vehicle speed sensor is faulty. ● ASCD control unit internal circuit is malfunctioning. 	<ul style="list-style-type: none"> ● ASCD is deactivated. ● Vehicle speed memory is canceled.
<ul style="list-style-type: none"> ● ASCD brake switch or stop lamp switch is faulty. 	<ul style="list-style-type: none"> ● ASCD is deactivated. ● Vehicle speed memory is not canceled.

CONSULT-II Inspection Procedure

1. Turn ignition switch OFF.
2. Connect CONSULT-II and CONSULT-II CONVERTER to data link connector.

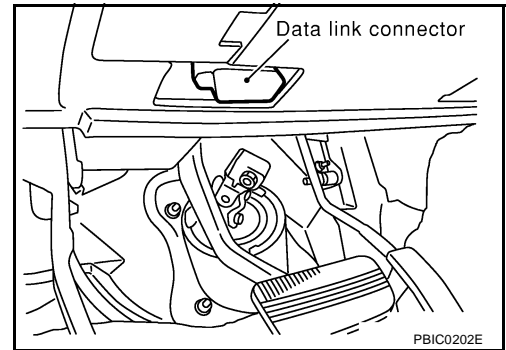

3. Turn ignition switch ON.
4. Turn MAIN (CRUISE) switch ON.
5. Touch START (NISSAN BASED VHCL) (on CONSULT-II display).
6. Touch ASCD.
If "ASCD" is not indicated, go to [GI-38, "CONSULT-II Data Link Connector \(DLC\) Circuit"](#).

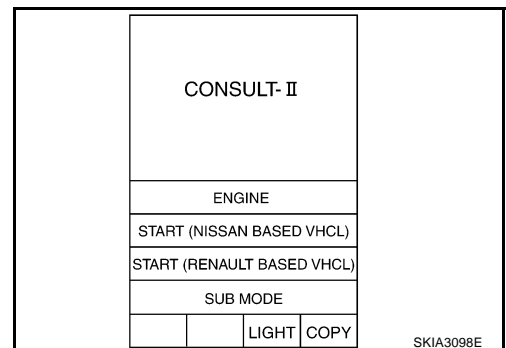

7. Touch SELF-DIAG RESULTS.

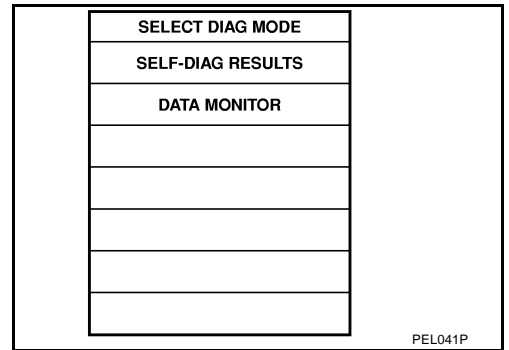

- Self-diagnostic results are shown on display.
Refer to [ACS-15, "CONSULT-II Self-diagnostic Results"](#) table.

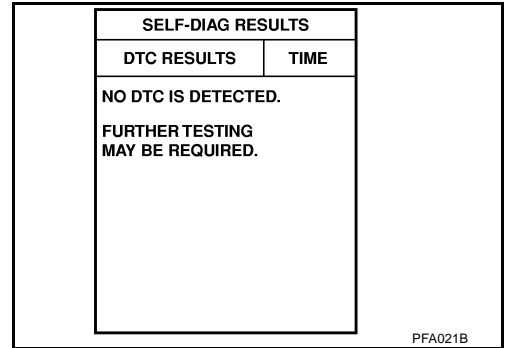

8. Touch DATA MONITOR.

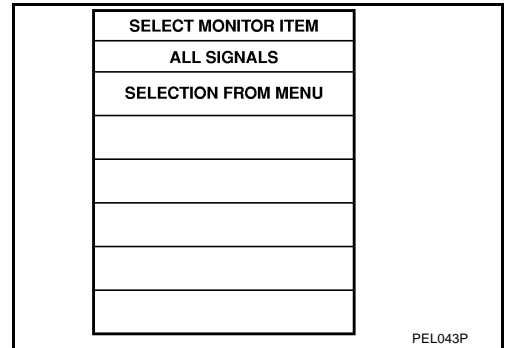

- Touch START.
- Data monitor results are shown on display.
Refer to [ACS-16, "CONSULT-II Data Monitor"](#) table.

For further information, read the CONSULT-II Operation Manual.

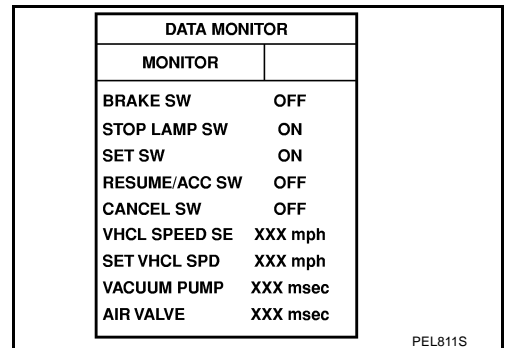

CONSULT-II Self-diagnostic Results

EKS0030D

Diagnostic item	Description	Repair/Check order
NO DTC IS DETECTED. FURTHER TESTING MAY BE REQUIRED.	<ul style="list-style-type: none"> ● Even if no malfunction is indicated, further testing may be required as far as the customer complains. 	—
POWER SUPPLY-VALVE	<ul style="list-style-type: none"> ● The power supply circuit for the ASCD pump is open. (An abnormally high voltage is entered.) 	ASCD PUMP CIRCUIT CHECK ACS-24
VACUUM PUMP	<ul style="list-style-type: none"> ● The vacuum motor circuit is open or shorted. (An abnormally high or low voltage is entered.) 	ASCD PUMP CIRCUIT CHECK ACS-24

AUTOMATIC SPEED CONTROL DEVICE (ASCD)

[ASCD]

Diagnostic item	Description	Repair/Check order
AIR VALVE	<ul style="list-style-type: none"> The air valve circuit is open or shorted. (An abnormally high or low voltage is entered.) 	ASCD PUMP CIRCUIT CHECK ACS-24
RELEASE VALVE	<ul style="list-style-type: none"> The release valve circuit is open or shorted. (An abnormally high or low voltage is entered.) 	ASCD PUMP CIRCUIT CHECK ACS-24
VHCL SP-S/FAILSAFE	<ul style="list-style-type: none"> The vehicle speed sensor is malfunctioning. 	VEHICLE SPEED SENSOR CHECK ACS-23
CONTROL UNIT	<ul style="list-style-type: none"> The ASCD control unit is malfunctioning. 	Replace ASCD control unit
BRAKE SW/STOP/L SW	<ul style="list-style-type: none"> The brake switch or stop lamp switch circuit is malfunctioning. 	ASCD BRAKE/STOP LAMP SWITCH CHECK ACS-20
COMMAND SW	<ul style="list-style-type: none"> The steering switch (SET/COAST switch, RESUME/ACCEL switch or CANCEL switch) is malfunctioning. 	ASCD STEERING SWITCH CHECK ACS-22
ECM	<ul style="list-style-type: none"> The ECM is malfunctioning. 	ECM SIGNAL CHECK ACS-27

CONSULT-II Data Monitor

EKS0030E

Monitored item	Description
BRAKE SW	<ul style="list-style-type: none"> Indicates [ON/OFF] condition of the brake switch and park/neutral position relay.
AT OD MONITOR	<ul style="list-style-type: none"> Indicates [ON/OFF] condition of A/T O/D (shift solenoid valve A).
STOP LAMP SW	<ul style="list-style-type: none"> Indicates [ON/OFF] condition of the stop lamp switch.
MAIN SW	<ul style="list-style-type: none"> Indicates [ON/OFF] condition of MAIN (CRUISE) switch.
SET SW	<ul style="list-style-type: none"> Indicates [ON/OFF] condition of the SET switch.
RESUME/ACC SW	<ul style="list-style-type: none"> Indicates [ON/OFF] condition of the RESUME/ACCEL switch.
CANCEL SW	<ul style="list-style-type: none"> Indicates [ON/OFF] condition of the CANCEL.
VHCL SPEED SE	<ul style="list-style-type: none"> The present vehicle speed computed from the vehicle speed sensor signal is displayed.
SET VHCL SPD	<ul style="list-style-type: none"> The preset vehicle speed is displayed.
VACUUM PUMP	<ul style="list-style-type: none"> The operation time of the vacuum pump is displayed.
AIR VALVE	<ul style="list-style-type: none"> The operation time of the air valve is displayed.
PW SUP-VALVE	<ul style="list-style-type: none"> Indicates [ON/OFF] condition of the circuit for the air valve and the release valve.
CRUISE LAMP	<ul style="list-style-type: none"> Indicates [ON/OFF] condition of the set lamp.
MAIN LAMP	<ul style="list-style-type: none"> Indicates [ON/OFF] condition of cruise lamp.
A/T-OD CANCEL	<ul style="list-style-type: none"> Indicates [ON/OFF] condition of the OD cancel.
FAIL SAFE-LOW	<ul style="list-style-type: none"> The fail-safe (LOW) circuit function is displayed.
FAIL SAFE-SPD	<ul style="list-style-type: none"> The fail-safe (SPEED) circuit function is displayed.
TCS MONITOR	<ul style="list-style-type: none"> Indicates [ON/OFF] condition of TCS.
THRTL POS SEN	<ul style="list-style-type: none"> The voltage of throttle position sensor is displayed.
R/LORD ESTMT	<ul style="list-style-type: none"> The present road/load computed by ASCD control unit is displayed.

AUTOMATIC SPEED CONTROL DEVICE (ASCD)

[ASCD]

EKS0030F

Trouble Diagnoses SYMPTOM CHART

PROCEDURE	Diagnostic procedure								
REFERENCE PAGE (ACS-)	ACS-18	ACS-19	ACS-20	ACS-22	ACS-23	ACS-24	ACS-26	ACS-27	ACS-28
SYMPTOM	FAIL-SAFE SYSTEM CHECK	POWER SUPPLY AND GROUND CIRCUIT CHECK	ASCD BRAKE/STOP LAMP SWITCH CHECK	ASCD STEERING SWITCH CHECK	VEHICLE SPEED SENSOR CHECK	ASCD PUMP CIRCUIT CHECK	ASCD ACTUATOR/PUMP CHECK	ECM SIGNAL CHECK	TCS MONITOR CHECK
ASCD cannot be set. ("CRUISE" indicator lamp does not ON.)		X		X*3					
ASCD cannot be set. ("SET" indicator lamp does not blink.)			X	X	X			X	
ASCD cannot be set. ("SET" indicator lamp blinks.*1)	X		X	X	X	X			
Vehicle speed does not decrease after SET/COAST switch has been pressed.				X			X		
Vehicle speed does not return to the set speed after RESUME/ACCEL switch has been pressed.*2				X			X		
Vehicle speed does not increase after RESUME/ACCEL switch has been pressed.				X			X		X
System is not released after CANCEL switch (steering) has been pressed.				X			X		
Large difference between set speed and actual vehicle speed.					X	X	X		X
Deceleration is greatest immediately after ASCD has been set.					X	X	X		X

*1: It indicates that system is in fail-safe. After completing diagnostic procedures, perform "FAIL-SAFE SYSTEM CHECK" ([ACS-18](#)) to verify repairs.

*2: If vehicle speed is greater than 40 km/h (25 MPH) after system has been released, pressing RESUME/ACCEL switch returns vehicle speed to the set speed previously achieved. However, doing so when the MAIN (CRUISE) switch is turned to "OFF", vehicle speed will not return to the set speed since the memory is canceled.

*3: Check only MAIN (CRUISE) switch built-in steering switch.

FAIL-SAFE SYSTEM CHECK

1. Turn ignition switch to ON position.
2. Turn MAIN (CRUISE) switch to ON and check if the "set indicator" blinks.

If the indicator lamp blinks, check the following.

- ASCD steering switch. Refer to [ACS-22, "ASCD STEERING SWITCH CHECK"](#).

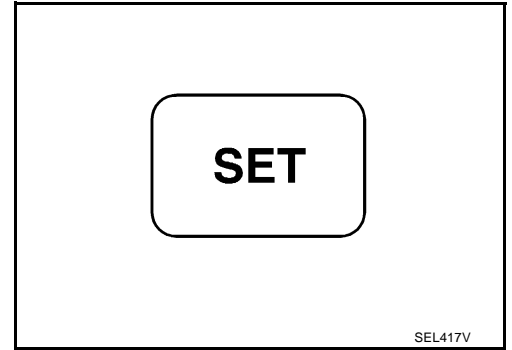

3. Drive the vehicle at more than 40 km/h (25 MPH) and push SET/COAST switch.

If the indicator lamp blinks, check the following.

- Vehicle speed sensor. Refer to [ACS-23, "VEHICLE SPEED SENSOR CHECK"](#).
- ASCD pump circuit. Refer to [ACS-24, "ASCD PUMP CIRCUIT CHECK"](#).
- If vehicle speed sensor and ASCD pump circuit are OK, replace ASCD control unit.

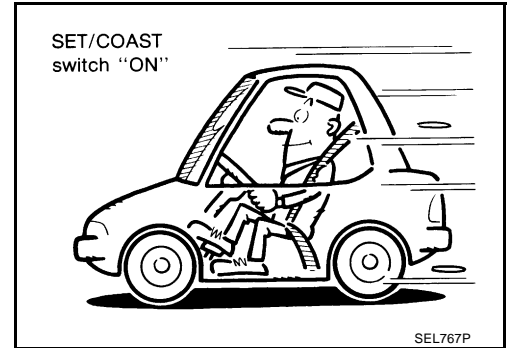

4. Depress brake pedal slowly (brake pedal should be depressed more than 5 seconds).

If the indicator lamp blinks, check the following.

- ASCD brake/stop lamp switch. Refer to [ACS-20, "ASCD BRAKE/STOP LAMP SWITCH CHECK"](#).

5. END. (System is OK.)

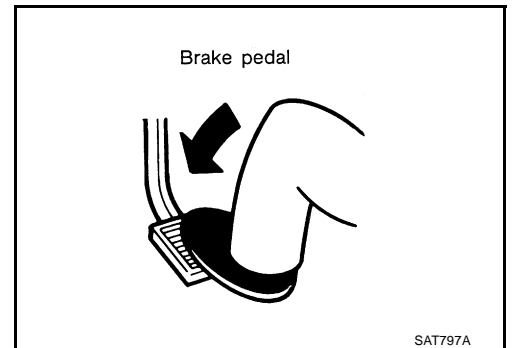

POWER SUPPLY AND GROUND CIRCUIT CHECK

1. CHECK POWER SUPPLY CIRCUIT FOR ASCD CONTROL UNIT

1. Disconnect ASCD control unit harness connector.
2. Turn ignition switch ON.
3. Check voltage between ASCD control unit harness connector M35 terminal 5 (W/G) and ground.

Dose battery voltage exist?

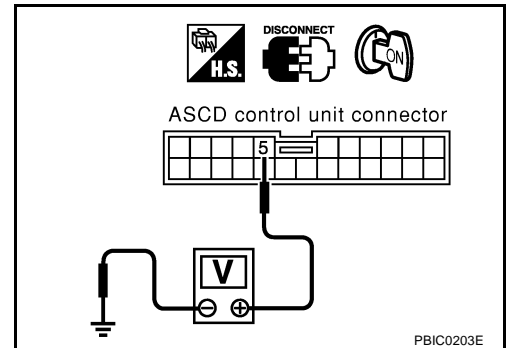

Refer to wiring diagram in [ACS-8, "FIG. 1"](#) .

Yes or No

- Yes >> GO TO 2.
 No >> Check the following.
- 10A fuse [No. 12 located in the fuse block (J/B) NO.1]
 - Harness for open or short

2. CHECK GROUND CIRCUIT FOR ASCD CONTROL UNIT

Check continuity between ASCD control unit harness connector M35 terminal 4 (B/W), 17(B) and ground.

Dose continuity exist?

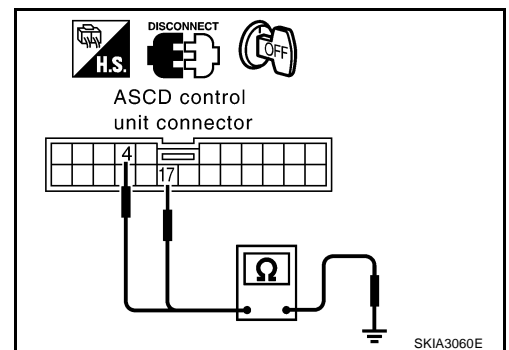

Refer to wiring diagram in [ACS-8, "FIG. 1"](#) .

Yes or No

- Yes >> Power supply and ground circuit is OK.
 No >> Repair harness or connector.

A
B
C
D
E
F
G
H
I
J
L
M

ACS

ASCD BRAKE/STOP LAMP SWITCH CHECK

1. CHECK ASCD BRAKE SWITCH CIRCUIT

④ With CONSULT-II

See "BRAKE SW" in "DATA MONITOR" mode.

- when brake pedal is depressed or A/T selector lever is in "N" or "P" range: BRAKE SW OFF**
- When brake pedal is released and A/T selector lever is not in "N" or "P" range: BRAKE SW ON**

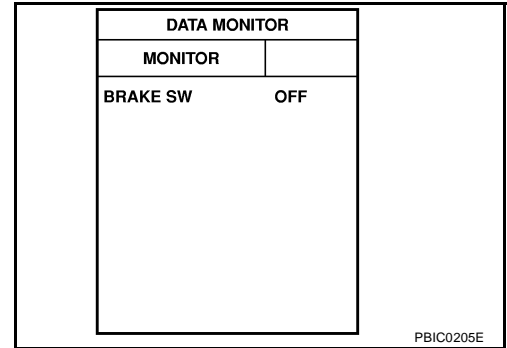

⊗ Without CONSULT-II

1. Disconnect ASCD control unit harness connector.
2. Turn ignition switch ON.
3. Check voltage between ASCD control unit harness connector M35 terminal 8 (GY/R) and ground.

- When brake pedal is depressed or A/T selector lever is in "N" or "P" range: Approx. 0 V**
- When brake pedal is released and A/T selector lever is not in "N" or "P" range: Battery voltage should exist.**

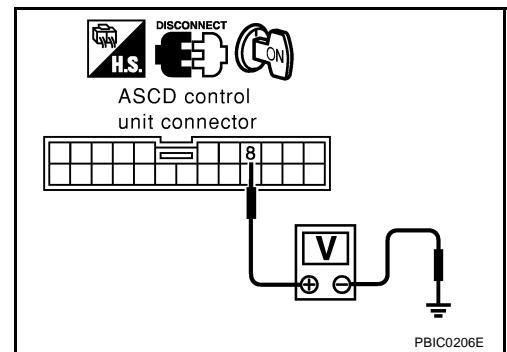

OK or NG

OK >> GO TO 2.

NG >> Check the following.

- ASCD brake switch
Refer to [ACS-29, "Electrical Component Inspection"](#) .
- Park/neutral position switch
Refer to [AT-244, "PARK/NEUTRAL POSITION, MANUAL MODE, BRAKE AND THROTTLE POSITION SWITCH CIRCUIT"](#) .
- Park/neutral position relay
Refer to [ACS-29, "Electrical Component Inspection"](#) .
- Harness for open or short

2. CHECK STOP LAMP SWITCH CIRCUIT

① With CONSULT-II

See "STOP LAMP" in "DATA MONITOR" mode.

When brake pedal is released: STOP LAMP SW OFF

When brake pedal is depressed: STOP LAMP SW ON

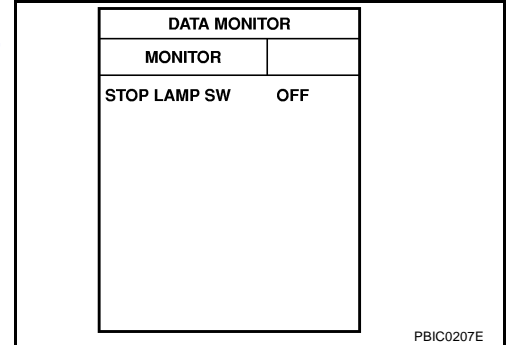

⊗ Without CONSULT-II

1. Disconnect ASCD control unit harness connector.
2. Check voltage between ASCD control unit harness connector M35 terminal 23 (R/W) and ground.

When brake pedal is released: 0 V

When brake pedal is depressed: Approx. 12 V

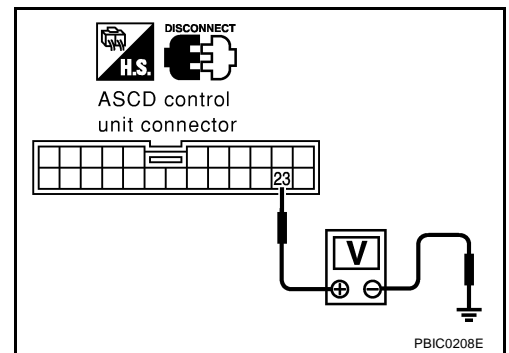

Refer to wiring diagram in [ACS-10, "FIG. 3"](#) .

OK or NG

OK >> ASCD brake/stop lamp switch is OK.

NG >> Check the following.

- 15A fuse [No. 17, located in the fuse block (J/B) NO.1]
- Harness for open or short between ASCD control unit and stop lamp switch
- Harness for open or short between fuse and stop lamp switch
- Stop lamp switch

Refer to [ACS-29, "Electrical Component Inspection"](#) .

A
B
C
D
E
F
G
H
I
J
L
M

ACS

ASCD STEERING SWITCH CHECK

1. CHECK ASCD STEERING SWITCH CIRCUIT FOR ASCD CONTROL UNIT

With CONSULT-II

See "MAIN SW", "RESUME/ACC SW", "SET SW" and "CANCEL SW" in "DATA MONITOR" mode.

**MAIN SW, RESUME/ACC SW,
SET SW and CANCEL SW**

When switch is depressed: ON

When switch is released: OFF

DATA MONITOR	
MONITOR	
MAIN SW	OFF
SET SW	OFF
RESUME/ACC SW	OFF
CANCEL SW	OFF

PBIC0209E

Without CONSULT-II

Check voltage between ASCD control unit harness connector M35 terminal 11 (G/OR) and ground.

Switch	Condition	Voltage [V]
MAIN (CRUISE) SW	Depressed	0
	Released	Approx. 4.0
SET SW	Depressed	Approx. 2.0
	Released	Approx. 4.0
RESUME/ACC SW	Depressed	Approx. 3.0
	Released	Approx. 4.0
CANCEL SW	Depressed	Approx. 1.0
	Released	Approx. 4.0

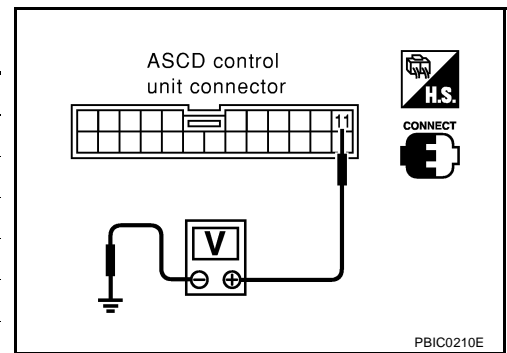

Refer to wiring diagram in [ACS-11, "FIG. 4"](#) .

OK or NG

OK >> ASCD steering switch is OK.

NG >> GO TO 2.

2. CHECK ASCD STEERING SWITCH

1. Disconnect ASCD steering switch.
2. Check resistance between M442 terminals 1 and 2 by depressing each switch.

Switch	Condition	Resistance [Ω]
MAIN (CRUISE) SW	Depressed	Approx. 0.3
	Released	Approx. 4,000
SET SW	Depressed	Approx. 661
	Released	Approx. 4,000
RESUME/ACC SW	Depressed	Approx. 1,486
	Released	Approx. 4,000
CANCEL SW	Depressed	Approx. 249
	Released	Approx. 4,000

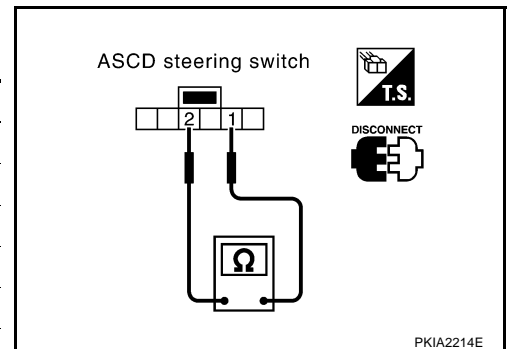

OK or NG

OK >> Check harness for open or short between ASCD steering switch and ASCD control unit.

NG >> Replace ASCD steering switch.

VEHICLE SPEED SENSOR CHECK

1. CHECK SPEEDOMETER OPERATION

Does speedometer operate normally?

Yes >> GO TO 2.

No >> Check speedometer and vehicle speed sensor circuit. Refer to [DI-18, "Inspection/Vehicle Speed Signal"](#) and [AT-43, "TROUBLE DIAGNOSIS"](#) .

2. CHECK VEHICLE SPEED INPUT

ⓑ With CONSULT-II

See "VHCL SPEED SE" in "DATA MONITOR" mode while driving.

NOTE:

- This test may be conducted with the drive wheels lifted in the shop or by driving the vehicle. If a road test is expected to be easier, it is unnecessary to lift the vehicle.
- Always drive vehicle in safe speed and manner according to traffic conditions and obey all traffic laws.

Is actual vehicle speed indicated?

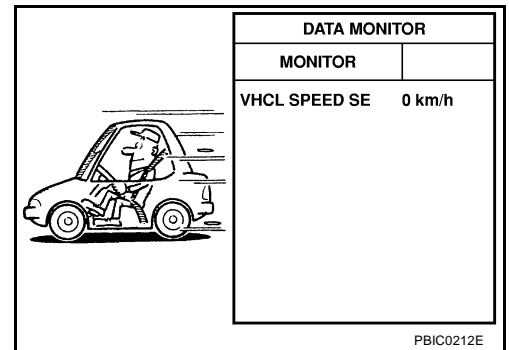

ⓧ Without CONSULT-II

1. Apply wheel chocks and jack up drive wheels.
2. Disconnect ASCD control unit harness connector.
3. Check voltage between ASCD control unit harness connector M35 terminal 22 (PU/W) and ground with turning drive wheels slowly by hand.

Dose voltage pointer deflect?

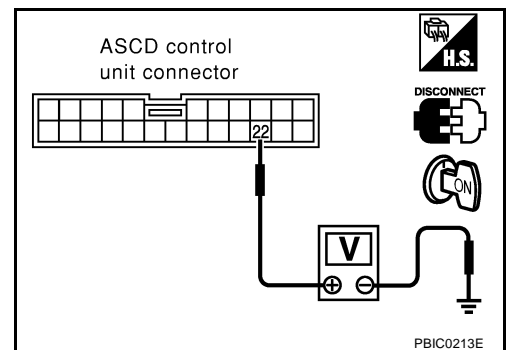

Refer to wiring diagram in [ACS-12, "FIG. 5"](#) .

Yes or No

Yes >> Vehicle speed sensor is OK.

No >> Check harness for open or short between ASCD control unit harness connector M35 terminal 22 (PU/W) and combination meter harness connector M41 terminal 18 (PU/W).

ASCD PUMP CIRCUIT CHECK

1. CHECK ASCD PUMP

1. Disconnect ASCD pump connector.
2. Measure resistance between ASCD pump terminals 1 and 2, 3, 4.

Terminals		Resistance [Ω]
1	2	Approx. 65
	3	Approx. 65
	4	Approx. 3

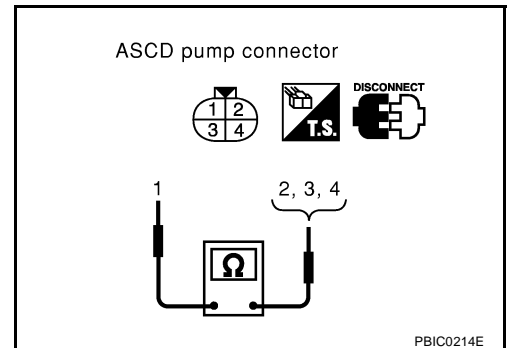

Refer to wiring diagram in [ACS-11, "FIG. 4"](#) .

OK or NG

- OK >> GO TO 2.
- NG >> Replace ASCD pump.

2. CHECK ASCD PUMP CIRCUIT

1. Disconnect ASCD control unit harness connector.
2. Check harness for open or short between ASCD control unit and ASCD pump.

Circuit	Terminal (Wire color)	
	ASCD control unit	ASCD pump
ASCD pump power supply	12 (R/L)	1 (R/L)
Air valve	13 (L/R)	2 (L/R)
Release valve	1 (L/Y)	3 (L/Y)
Vacuum motor	14 (W/R)	4 (W/R)

Continuity should exist.

OK or NG

- OK >> GO TO 3.
- NG >> Repair harness or connector.

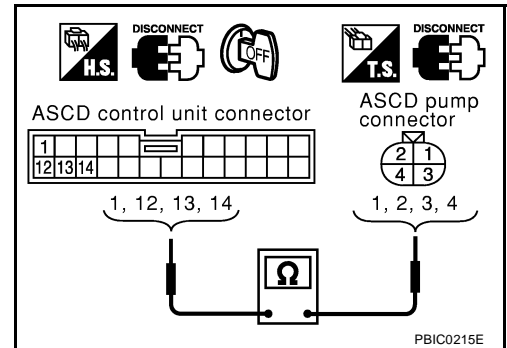

3. CHECK ASCD PUMP POWER SUPPLY

With CONSULT-II

1. Jack up the drive wheels.
2. See "PW SUP-VALVE" in "DATA MONITOR" mode.
3. Maintain the conditions below.
 - Vehicle speed is more than 40 km/h (25 MPH).
 - MAIN (CRUISE) switch (CRUISE lamp) is ON.
 - SET/COAST switch (SET lamp) is ON.

"PW SUP-VALVE" should be ON.

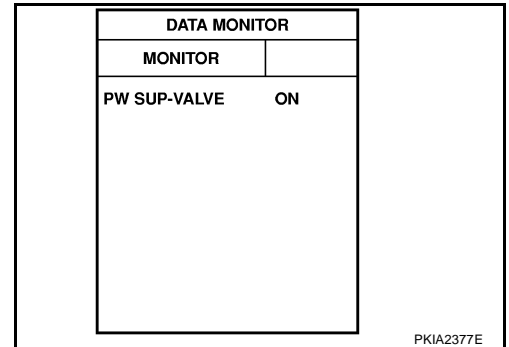

Without CONSULT-II

1. Jack-up the drive wheels.
2. Maintain the conditions below.
 - Vehicle speed is more than 40 km/h (25 MPH).
 - MAIN (CRUISE) switch (CRUISE lamp) is ON.
 - SET/COAST switch (SET lamp) is ON.

Check voltage between ASCD control unit harness connector M35 terminal 12 (R/L) and ground.

Battery voltage should exist.

OK or NG

- OK >> ASCD pump power supply is OK.
- NG >> Replace ASCD control unit.

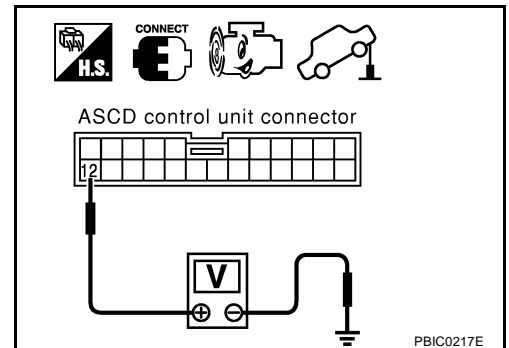

A
B
C
D
E
F
G
H
I
J
L
M

ACS

ASCD ACTUATOR/PUMP CHECK

1. CHECK VACUUM HOSE

Check vacuum hose (between ASCD actuator and ASCD pump) for breakage, cracks or fracture.

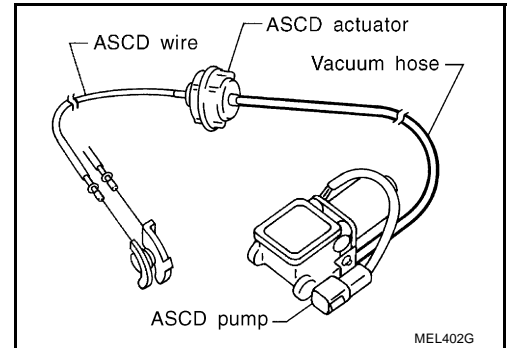

OK or NG

- OK >> GO TO 2.
- NG >> Repair or replace vacuum hose.

2. CHECK ASCD WIRE

Check wire for improper installation, rust formation or breaks.

OK or NG

- OK >> GO TO 3.
- NG >> Repair or replace wire. Refer to [ACS-29, "ASCD Wire Adjustment"](#).

3. CHECK ASCD ACTUATOR

1. Disconnect vacuum hose from ASCD actuator.
2. Connect the hose of hand vacuum pump to ASCD actuator.

Apply -40 kPa (-0.41 kg/cm^2 , -5.8 psi) vacuum to ASCD actuator with hand vacuum pump.

ASCD wire should move to pull throttle drum.

Wait 10 seconds and check for decrease in vacuum pressure.

Vacuum pressure decrease:	Less than 2.7 kPa (0.028 kg/cm^2, 0.39 psi)
----------------------------------	---

OK or NG

- OK >> GO TO 4.
- NG >> Replace ASCD actuator.

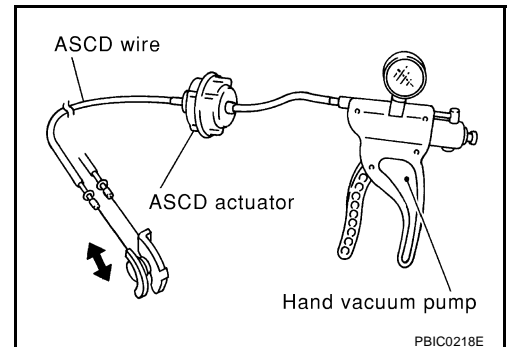

4. CHECK ASCD PUMP

1. Disconnect vacuum hose from ASCD pump and ASCD pump harness connector.
2. If necessary remove ASCD pump.
3. Connect vacuum gauge to ASCD pump.
4. Apply 12V direct current to ASCD pump and check operation.

	12V direct current supply terminals		Operation
	(+)	(-)	
Air valve	1	2	Close
Release valve		3	Close
Vacuum motor		4	Operate

A vacuum pressure of at least -40 kPa (-0.41 kg/cm^2 , -5.8 psi) should be generated.

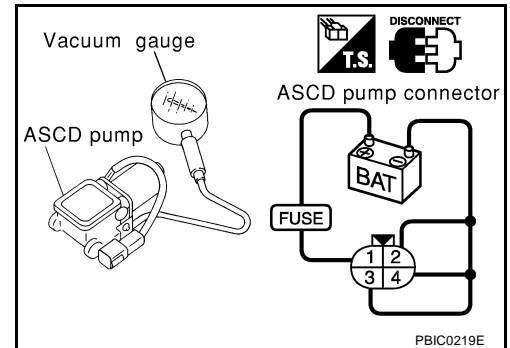

OK or NG

- OK >> INSPECTION END.
- NG >> Replace ASCD pump.

ECM SIGNAL CHECK

1. CHECK THROTTLE POSITION SENSOR SIGNAL CIRCUIT

1. Disconnect ECM harness connector and ASCD control unit harness connector.
2. Check continuity between ECM harness connector F102 terminal 113 (R/Y) and ASCD control unit harness connector M35 terminal 3 (R/Y).

Continuity should exist.

OK or NG

- OK >> GO TO 2.
- NG >> Repair harness or connector.

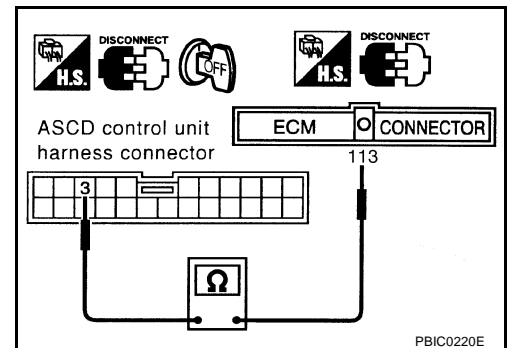

2. CHECK ECM COMMUNICATION CIRCUIT

1. Check continuity between ECM harness connector F101 terminal 39 (OR) and ASCD control unit harness connector M35 terminal 7 (OR).
2. Check continuity between ASCD control unit harness connector M35 terminal 7 (OR) and ground.

7 – 39 : Continuity should exist

7 – ground : Continuity should not exist.

OK or NG

- OK >> GO TO 3.
- NG >> Repair harness or connector.

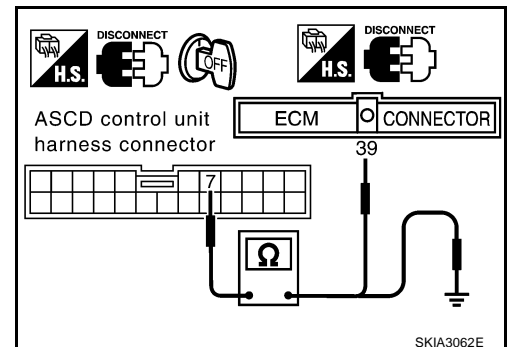

3. CHECK ECM

1. Check ECM.
Refer to [EC-405, "DTC P0605 ECM"](#) .

OK or NG

- OK >> Refer to [EC-130, "TROUBLE DIAGNOSIS FOR INTERMITTENT INCIDENT"](#) .
 NG >> Replace ECM.

TCS MONITOR CHECK

1. CHECK TCS MONITOR CIRCUIT

1. Turn ignition key switch OFF.
2. Remove instrument lower driver panel.
3. Remove ASCD control unit connectors and TCS control unit connectors.
4. Check continuity between ASCD control unit harness connector M35 terminal 2 (SB) and TCS control unit harness connector E218 terminal 84 (SB).

- 2 – 84 : Continuity should exist**
2 – ground : Continuity should not exist.

OK or NG

- OK >> GO TO 2.
 NG >> Repair harness or connector.

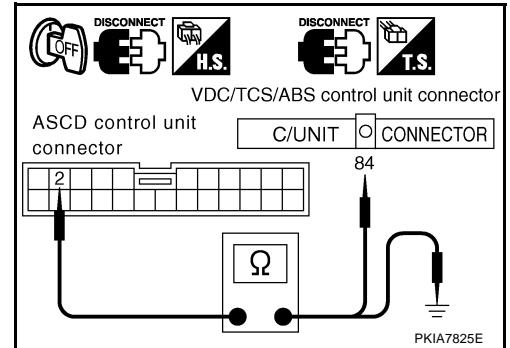

2. CHECK TCS CONTROL UNIT

- Check TCS Control unit. Refer to [BRC-39, "Inspection 3 VDC/TCS/ABS Control Unit System"](#) .

OK or NG

- OK >> TCS control unit is OK.
 NG >> Replace TCS control unit.

Electrical Component Inspection ASCD BRAKE SWITCH AND STOP LAMP SWITCH

Condition	Continuity	
	ASCD brake switch	Stop lamp switch
When brake pedal is depressed	No	Yes
When brake pedal is released	Yes	No

Check each switch after adjusting brake pedal — refer to [BR-6](#), "[BRAKE PEDAL](#)".

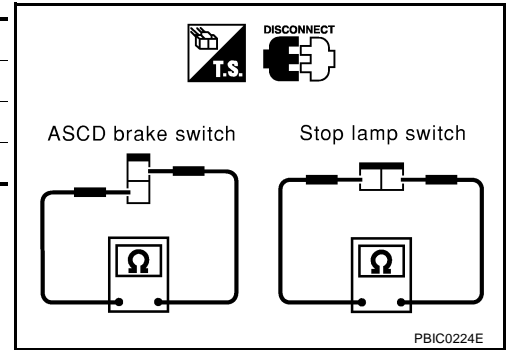

PARK/NEUTRAL POSITION RELAY

	Continuity
	Between terminals 3 and 4
Battery voltage supply	No
Battery voltage not supply	Yes

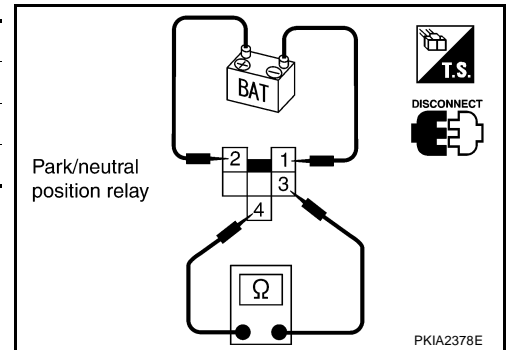

ASCD Wire Adjustment

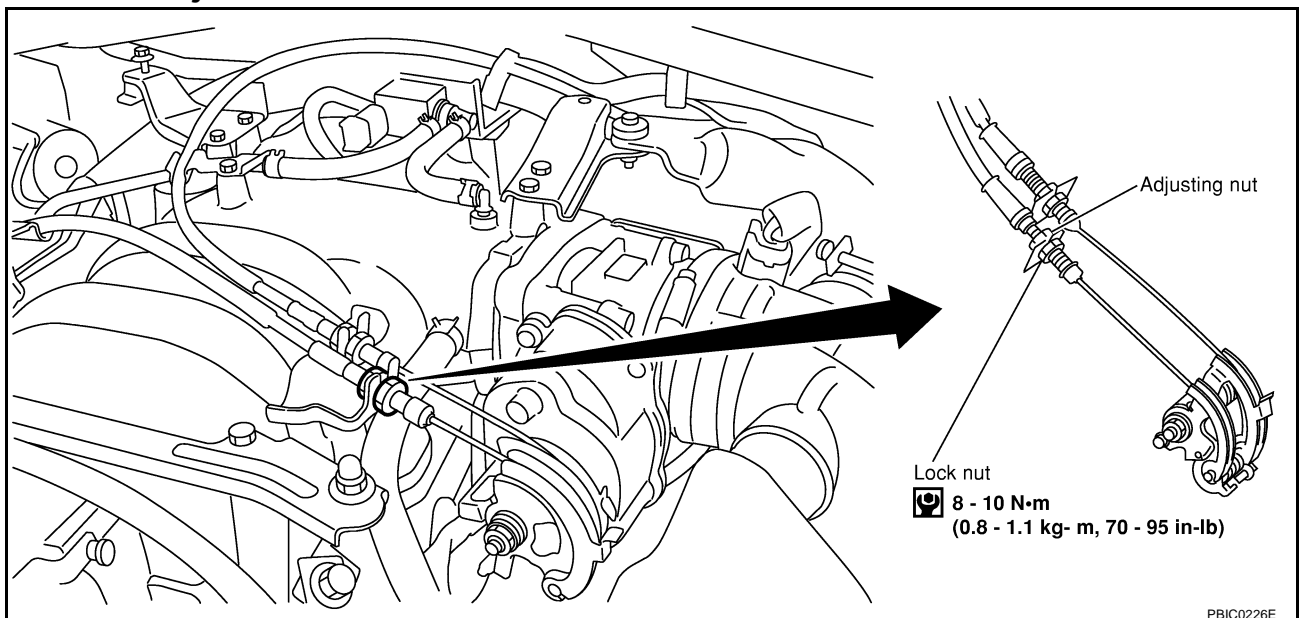

CAUTION:

- Be careful not to twist ASCD wire when removing it.
- Do not tense ASCD wire excessively during adjustment.

Adjust the tension of ASCD wire in the following manner.

1. Loosen lock nut and adjusting nut.
2. Make sure that accelerator wire is properly adjusted. Refer to [ACC-2](#), "[ACCELERATOR CONTROL SYSTEM](#)".
3. Tighten adjusting nut just until throttle drum starts to move.
4. Loosen adjusting nut again 1/2 to 1 turn.
5. Tighten lock nut to specified torque holding the adjusting nut.

SERVICE DATA AND SPECIFICATIONS (SDS)

[ASCD]

SERVICE DATA AND SPECIFICATIONS (SDS)

PFP:00030

Standard and Limit

EKS0030I

Turning back of ASCD cable adjusting nut

1/2 - 1.0 turns (From position throttle drum just starts to move)

Tightening Torque

EKS0030J

Unit: N·m (kg-m, ft-lb)

Unit: N·m (kg-m, in-lb)*

ACSD cable lock nut		8 - 10 (0.8 - 1.1, 70 - 95)*
ASCD actuator	Bolt	4.4 - 5.8 (0.45 - 0.59, 39 - 51)*
	Nut	10.8 - 13.7 (1.1 - 1.3, 8 - 10)
ASCD control unit		2.9 - 3.9 (0.30 - 0.39, 26 - 34)*

PRECAUTIONS

PPF:00001

Precautions for Supplemental Restraint System (SRS) “AIR BAG” and “SEAT BELT PRE-TENSIONER”

EKS006S9

The Supplemental Restraint System such as “AIR BAG” and “SEAT BELT PRE-TENSIONER”, used along with a front seat belt, helps to reduce the risk or severity of injury to the driver and front passenger for certain types of collision. This system includes seat belt switch inputs and dual stage front air bag modules. The SRS system uses the seat belt switches to determine the front air bag deployment, and may only deploy one front air bag, depending on the severity of a collision and whether the front occupants are belted or unbelted. Information necessary to service the system safely is included in the SRS and SB section of this Service Manual.

WARNING:

- To avoid rendering the SRS inoperative, which could increase the risk of personal injury or death in the event of a collision which would result in air bag inflation, all maintenance must be performed by an authorized NISSAN/INFINITI dealer.
- Improper maintenance, including incorrect removal and installation of the SRS, can lead to personal injury caused by unintentional activation of the system. For removal of Spiral Cable and Air Bag Module, see the SRS section.
- Do not use electrical test equipment on any circuit related to the SRS unless instructed to in this Service Manual. SRS wiring harnesses can be identified by yellow and/or orange harnesses or harness connectors.

Precautions for ICC System Service

EKS003S3

- Do not look straight into the laser beam discharger when adjusting laser beam aiming.
- Turn the ON/OFF switch OFF in conditions similar to driving, suchlike Free rollers or a chassis dynamometer.
- Do not use the ICC sensor removing from vehicle, disassemble, or remodel the sensor.
- Erase DTCs when replacing parts of ICC system, then check the operation of ICC system after adjusting laser beam aiming if necessary.

Wiring Diagrams and Trouble Diagnosis

EKS003S4

When you read wiring diagrams, refer to the followings:

- Refer to [GI-14, "How to Read Wiring Diagrams"](#) in GI section
- Refer to [PG-2, "POWER SUPPLY ROUTING"](#) for power distribution circuit in PG section

When you perform trouble diagnosis, refer to the followings:

- Refer to [GI-10, "HOW TO FOLLOW TEST GROUPS IN TROUBLE DIAGNOSES"](#) in GI section
- Refer to [GI-26, "How to Perform Efficient Diagnosis for an Electrical Incident"](#) in GI section

A
B
C
D
E
F
G
H
I
J
L
M

ACS

PREPARATION

PFP:00002

Special Service Tools

EKS0030N

The actual shapes of Kent-Moore tools may differ from those of special service tools illustrated here.

Tool number (Kent – Moore No.) Tool name	Description
KV99110100 (J-45718) ICC target board	Laser beam aiming adjustment



PKIA0358J

DESCRIPTION

PPF:00000

Outline

EKS00300

The Intelligent Cruise Control (ICC) system automatically maintains a selected distance from the vehicle ahead according to that vehicle's speed, or at the set speed, if the road ahead is clear.

With ICC, the same speed as other vehicles can be maintained without the constant need to adjust the operating speed as with a normal cruise control system.

The system is intended to enhance the operation of the vehicle when following another vehicle in the same lane and direction.

If the distance sensor detects a slower moving vehicle ahead, the system will reduce speed so that the vehicle ahead can be followed at the selected distance.

The system automatically controls the throttle and applies the brakes (up to 25% of vehicle braking power) if necessary.

The detection range of the sensor is approximately 390 ft (120 m) ahead.

Refer to Owner's Manual for Intelligent Cruise Control System operating instructions.

BRAKE ASSIST (WITH PREVIEW FUNCTION)

When the force applied to brake pedal exceeds a certain level, the Brake Assist is activated and generates a greater braking force than that of a conventional brake booster even with light pedal force.

When the Preview Function identifies the need to apply the sudden brake by sensing the vehicle ahead in the same lane and the distance and relative speed from it, it applies the brake pre-pressure before driver depress the brake pedal and improves brake response by reducing its free play.

Refer to Owner's Manual for BRAKE ASSIST (WITH PREVIEW FUNCTION) operating instructions.

System Diagram

EKS0030P

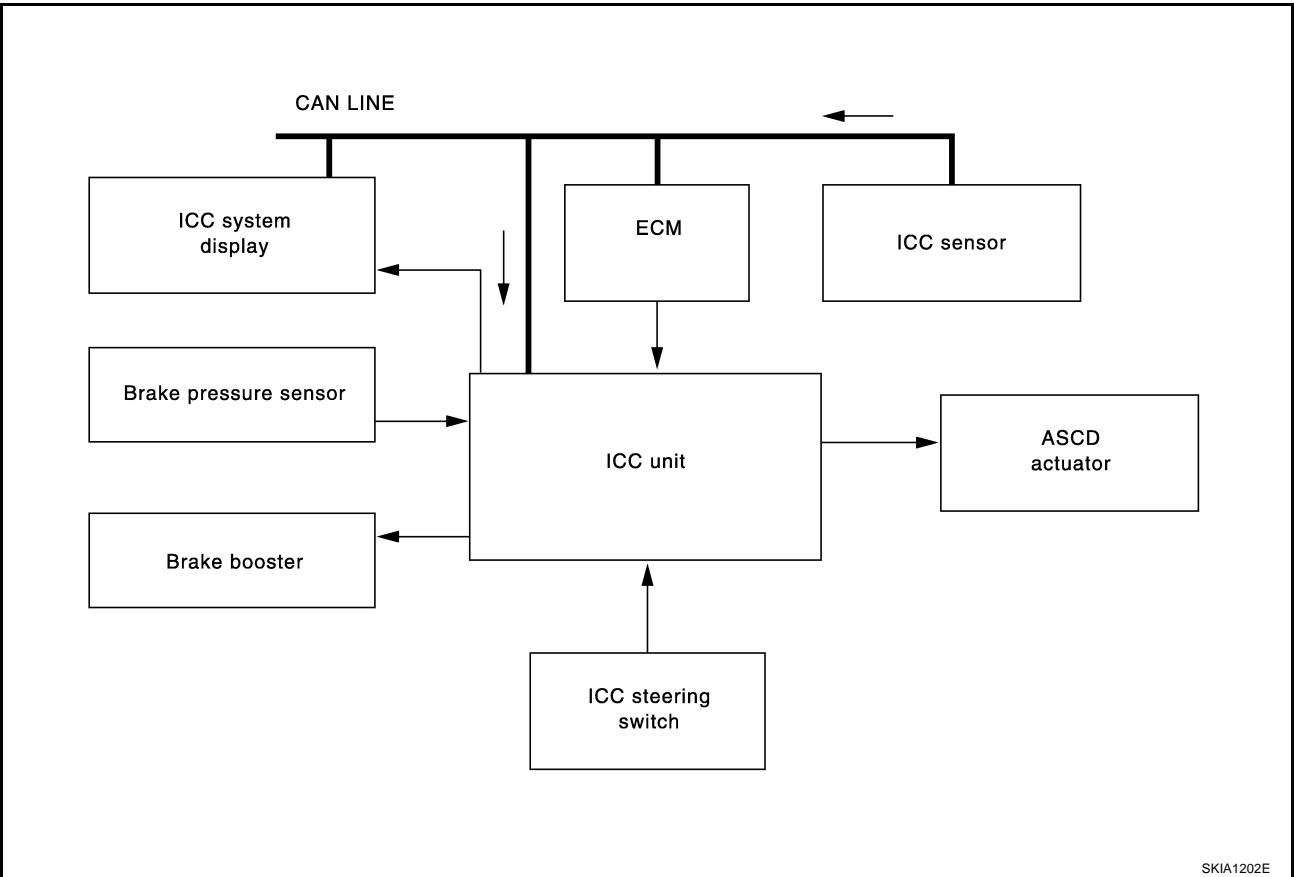

SKIA1202E

Components Description

EKS0030Q

Component	ICC system	Brake assist (with pre-view brake)	Description
ICC unit	×	×	Operates ASCD actuator and brake booster based on that sensor signals and CAN communication data, then controls vehicle distance.
ICC sensor	×	×	Irradiate laser beam, and receives reflected laser beam to measure distance from preceding vehicle.
ECM	×		Transmits throttle angle signal to ICC unit.
Brake pressure sensor	×	×	Detects fluid pressure in master cylinder.
ASCD actuator	×		Based on command from ICC unit, adjust throttle valve angle with ASCD actuator, using vacuum emerged from vacuum pump.
Brake booster	×	×	Adjusts brake fluid pressure, based on command from ICC unit.

CAN Communication

EKS0030R

CAN (Controller Area Network) is a serial communication line for real time application. It is an on-vehicle multiplex communication line with high data communication speed and excellent error detection ability. Many electric control units are equipped onto a vehicle, and each control unit shares information and links with other control units during operation (not independent). In CAN communication, control units are connected with 2 communication lines (CAN H line, CAN L line) allowing a high rate of information transmission with less wiring. Each control unit transmits/receives data but selectively reads required data only.

CAN COMMUNICATION UNIT

Refer to [LAN-21, "CAN Communication Unit"](#) .

Switch Operation

EKS0030S

The system is operated by a master ON/OFF switch and four control switches, all mounted on the steering wheel

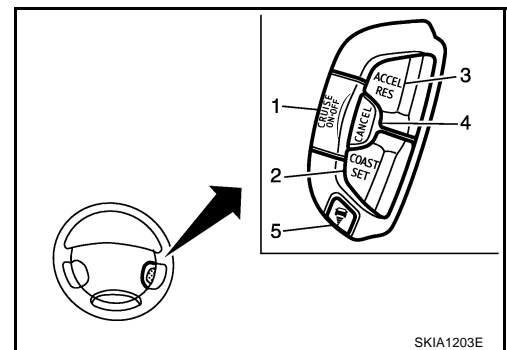

SKIA1203E

No.	Switch name	Description
1	ON/OFF switch	Master switch to activate the system
2	COAST/SET switch	Sets desired cruise speed, reduces speed incrementally
3	ACCELERATE/RESUME switch	Resumes set speed or increases speed incrementally
4	CANCEL switch	Deactivates system without erasing set speed
5	DISTANCE switch	Changes the following distance from: Long, Middle, Short

ICC System Display

EKS0030T

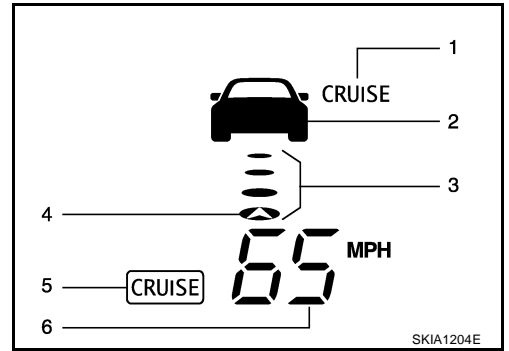

A
B
C
D
E
F
G
H
I
J
L
M

No.	Component	Description
1	Intelligent cruise control system warning lamp (Orange)	The light comes on if there is a malfunction in the ICC system.
2	Vehicle ahead detection indicator	Indicates whether it detects a vehicle ahead.
3	Set distance indicator	Display the selected distance between vehicles set with the DISTANCE switch.
4	Own vehicle indicator	Indicates the base vehicle.
5	ON/OFF switch indicator lamp (White)	Indicates that the ON/OFF switch is ON.
6	Set vehicle speed indicator	Indicates the set vehicle speed.

ACS

ACTION TEST

ICC System Running Test ICC SYSTEM SET CHECKING

1. Turn on the ON/OFF switch.
2. Drive the vehicle between 25 MPH (40 km/h for CANADA models) and 90 MPH (144 km/h for CANADA models).
3. Push the COAST/SET switch.
4. Confirm that the desired speed is set as hand is released from the COAST/SET switch.

NOTE:

- When there is no vehicle ahead, drive at the set speed steadily.
- When there is a vehicle ahead, control to maintain distance from the vehicle ahead, watching its speed.
- The set vehicle speed is displayed on the ICC system indicator in the combination meters.

CHECK FOR INCREASE OF THE CRUISING SPEED

1. Set the ICC at desired speed.
2. Check if the set speed increases by 1 MPH (1 km/h for CANADA models) as ACCELERATE/RESUME switch is pushed.

NOTE:

The maximum set speed of the ICC system is 90 MPH (144 km/h for CANADA models).

CHECK FOR DECREASE OF THE CRUISING SPEED

1. Set the ICC at desired speed.
2. Check if the set speed decreases by 1 MPH (1 km/h for CANADA models) as COAST/SET switch is pushed.

NOTE:

- ICC system is automatically turned off when the driving speed lowers to 20 MPH (32 km/h for CANADA models) due to the deceleration of the vehicle ahead.
- The lowest set speed is 25 MPH (40 km/h for CANADA models).

CHECK FOR THE CANCELLATION OF ICC SYSTEM (NORMAL DRIVING CONDITION) IN THE FOLLOWING CASES:

1. When the brake pedal is depressed after the system is turned on.
2. When the select lever is shifted into other than "D" including manual shift.
3. When the ON/OFF switch is turned off.
4. When CANCEL switch is operated.

CHECK FOR RESTORING THE SPEED THAT IS SET BY ICC SYSTEM BEFORE ICC CANCELLATION

1. Cancel the system by depressing the foot brake. Then, check that the speed before cancellation is restored when pressing ACCEL/RES switch with 25 MPH (40 km/h for CANADA models) or above.
2. Cancel the system by shifting the select lever into other than "D", Then, check if the speed set before the cancellation is restored when ACCEL/ RES switch is pressed.
3. Check if the speed previously set is restored when ACCEL/RES switch is operated with driving 25 MPH(40 km/h for CANADA models), after canceling the ICC by operating the CANCEL switch.

CHECK FOR ON/OFF SWITCH

1. Start the engine. Then, check the following operations are carried correctly.
2. Intelligent Cruise Control (ICC) system is displayed in between the tachometer and speedometer illuminates when ON/OFF switch is ON and ready for operation. The illumination goes off when ON/OFF switch is turned to OFF.
3. "CRUISE" illumination and "ICC" system illumination go off when the key switch is turned to OFF while ON/OFF switch is ON ("CRUISE" illumination is ON and ICC system is ready for operation).

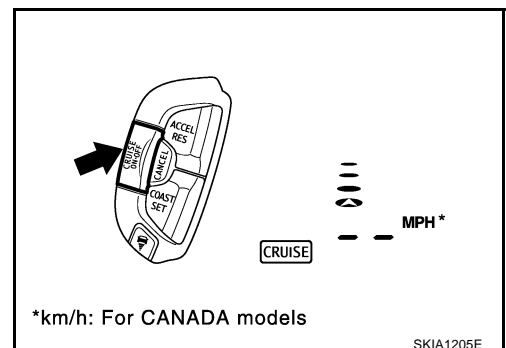

CHECK FOR ACCEL/RES, COAST/SET, CANCEL SWITCHES



1. Check if ACCEL/ RES, COAST/SET, CANCEL switches are operated smoothly.
2. Check if buttons come up as hand is released from the buttons.

CHECK FOR DISTANCE SWITCH

1. Start the engine.
2. Turn on the ON/OFF switch.
3. Press the DISTANCE switch.
4. Check if the set distance indicator changes display in order of: (long)→(middle)→(short).

NOTE:

The set distance indicator shows 'long' immediately after the engine starts.

Distance	Display	Approximate distance at 60 MPH (96 km/h) [ft (m)]
Long		195 (60)
Middle		150 (45)
Short		105 (32)

SKIA1206E

A

B

C

D

E

F

G

H

I

J

ACS

L

M

LASER BEAM AIMING ADJUSTMENT

Outline

EKS0030V

Adjust the laser beam aiming every time the ICC sensor is removed or installed.

CAUTION:

- Place the vehicle on the level ground when the laser beam aiming adjustment is operated.
- Follow the CONSULT-II when adjusting the Laser beam aiming (Laser beam aiming adjustment cannot be operated without CONSULT-II).

Preparation

EKS0030W

- Keep all tires inflated to correct pressures. Adjust the tire pressure to the specified pressure value.
- See that there is no-load in vehicle other than the driver (or equivalent weight placed in driver's position). Coolant, engine oil filled up to correct level and full fuel tank.
- Shift the gear into "P" position and release the parking brake.
- Clean the sensor with a soft cloth.

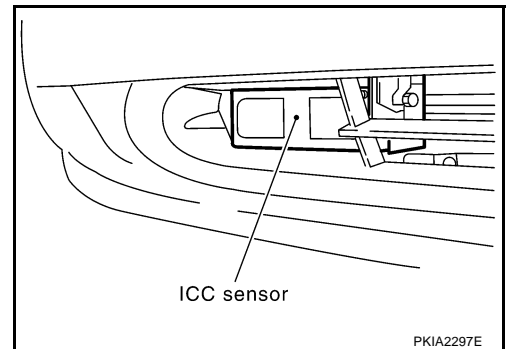

PKIA2297E

Outline of Adjustment Procedure

EKS0030X

1. Set up the ICC target board [KV99110100 (J-45718)].
2. Adjust the sensor following the procedure on CONSULT-II (Turn manually the screw for up-down position adjustment. ICC sensor automatically adjust the right-left position).

Setting the ICC Target Board

EKS0030Y

Accurate ICC target board setting is required for the laser beam aiming adjustment.

CAUTION:

ICC system does not function normally if laser beam aiming is not accurate.

ADJUSTING HEIGHT OF THE TARGET

1. Attach a triangle scale as shown in the right figure.

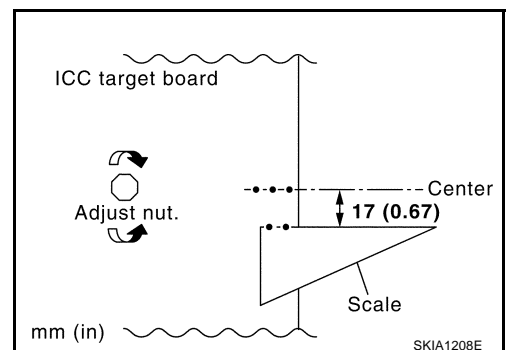

SKIA1208E

LASER BEAM AIMING ADJUSTMENT

[ICC]

- Adjust the height of the target stand so that the point of the triangle aims the center of the ICC sensor.

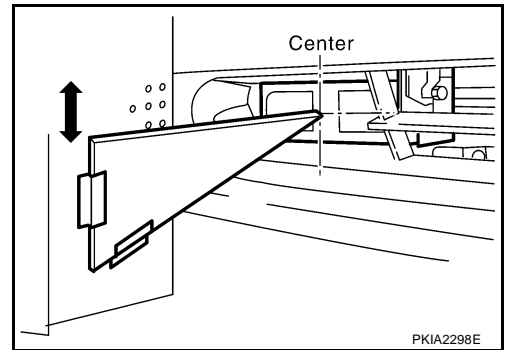

A
B
C
D

ADJUSTING THE RIGHT-LEFT POSITION OF THE TARGET

- Attach a scale (at least 300 mm[12 in] or longer) or stick as shown in the figure.

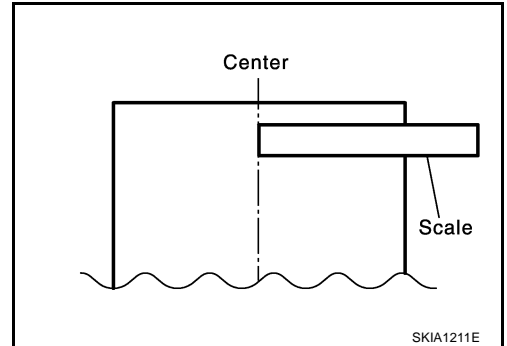

E
F
G

- Suspend a thread with weight on the tip of the thread to 275 mm (10.8 in) left side of the target board from the center of the target board on top.

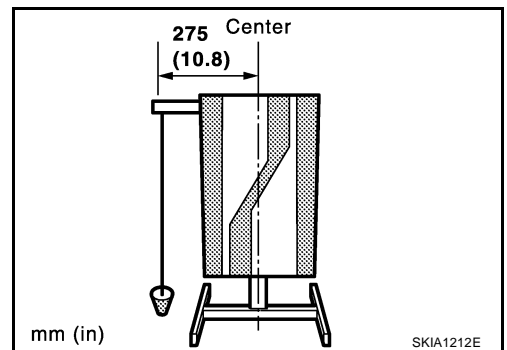

H
I
J

SETTING THE TARGET

- Suspend a thread with weight on tip to splice the center of the front and back bumpers. Then, mark the center point on the ground as each weight points.
- Link the front and back bumpers' center points marked on the ground, and mark a point 5 m ahead of the vehicle, on the extended line of the previous link line of the bumper center points. Then, adjust the position of the target board so that the weight come on the top of the marked point (5 m ahead of the vehicle) and face to the vehicle.
- Adjust the position of the target board so that the extended line that links the center of the rear wind shield (the center of the rear defogger pattern) and the center of the front wind shield (the setting part of the room mirror) align with the weight suspended from the board.

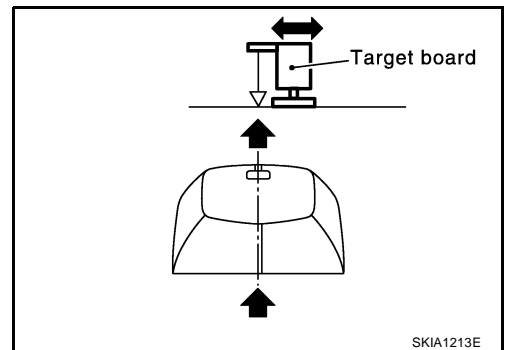

L
M

- Remove the thread suspended to the left side of board and suspend a thread with weight on tip on the center of the target board. Then mark the point of weight on the ground.

LASER BEAM AIMING ADJUSTMENT

[ICC]

- Pivot the edge of the target board 20° to either side.

NOTE:

50 mm(2 in) shift rates the 20° movement.

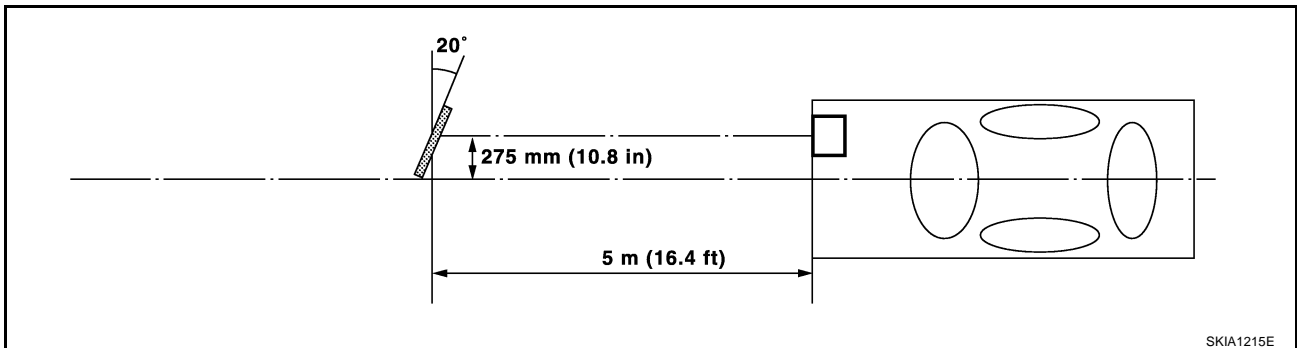
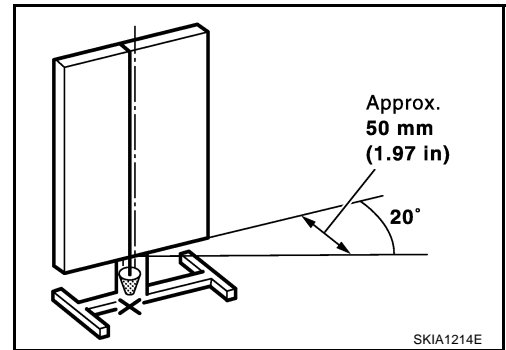

- Do not place anything in the space shown in the figure (view from top).

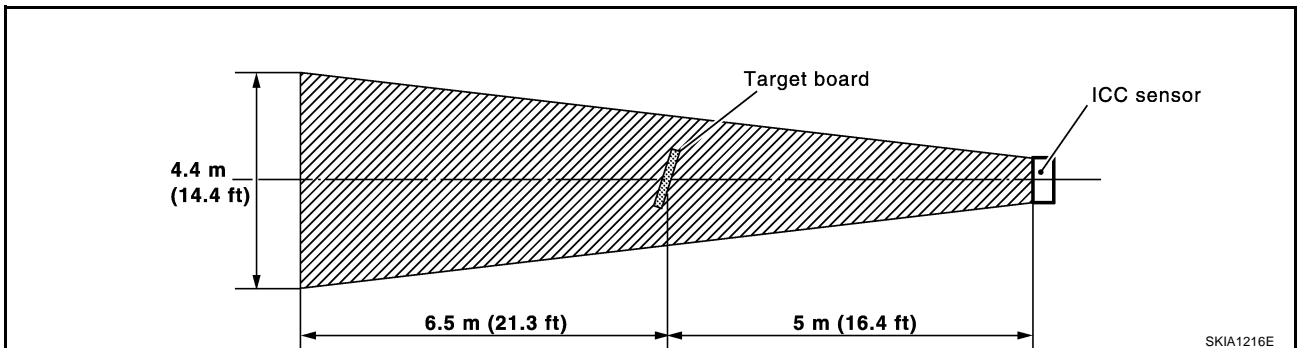

NOTE:

In case the space shown in the illustration is not available, make space by covering the side of the target board with a 400 mm(15.75 in)-size frosted black board or black cloth.

Aiming Adjustment

EKS003OZ

CAUTION:

Complete all necessary work for laser beam adjustment until the adjustment completes as shown in the procedure. If the procedure does not complete, the ICC system is inoperable.

- Turn ignition switch OFF.
- Connect CONSULT-II and CONSULT-II CONVERTER on the data link connector.

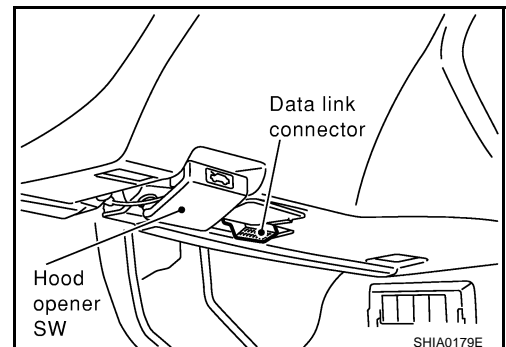

LASER BEAM AIMING ADJUSTMENT

[ICC]

- Start the engine, wait for at least 10 sec., and touch "START(NISSAN BASED VHCL)"

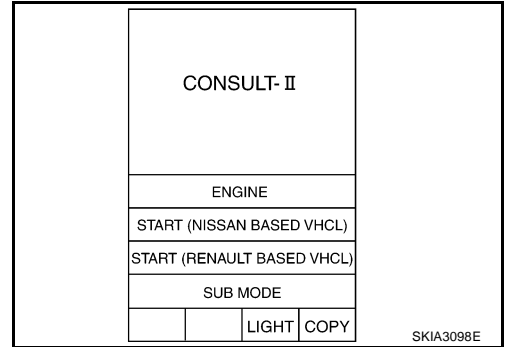

A
B
C
D

- Touch "ICC".
If "ICC" is not indicated, go to [GI-38. "CONSULT-II Data Link Connector \(DLC\) Circuit"](#).

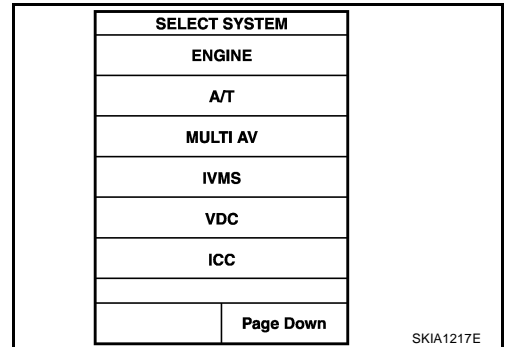

E
F
G

- Touch "WORK SUPPORT".

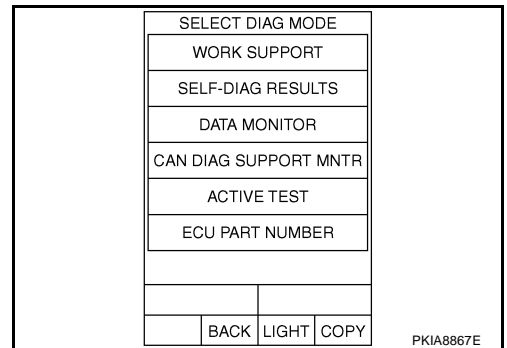

H
I
J

ACS

- Touch "LASER BEAM ADJUST".

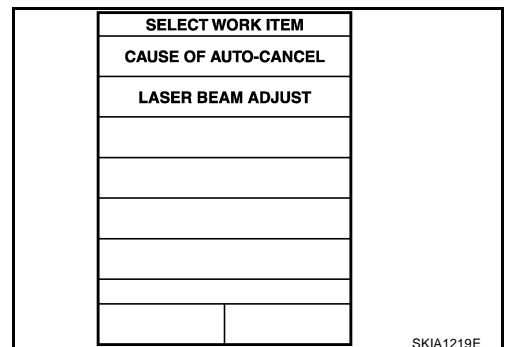

L
M

- Touch "START".

CAUTION:

If the adjustment screen does not appear on CONSULT-II 10 sec. After touching "LASER BEAM ADJUST" screen, the following causes may be considered:

- Target is not set accurately.
- There is not enough space beside the target.
- Deformation of vehicle or the surrounding equipment unit, bracket, or the surrounding equipment is causing inappropriate installation of sensor and aiming may be set out of the adjustable range.

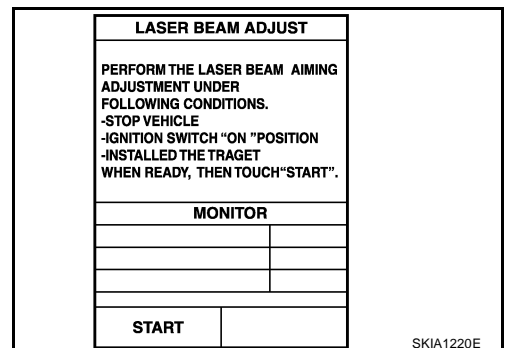

LASER BEAM AIMING ADJUSTMENT

[ICC]

11. Confirm that "NORMALLY COMPLETED" is displayed on CONSULT-II and close the aiming adjustment procedure by touching "END".

CAUTION:

Complete all the procedures once "LASER BEAM ADJUST" mode is entered in CONSULT-II. When the procedure is discontinued, the ICC system is inoperable.

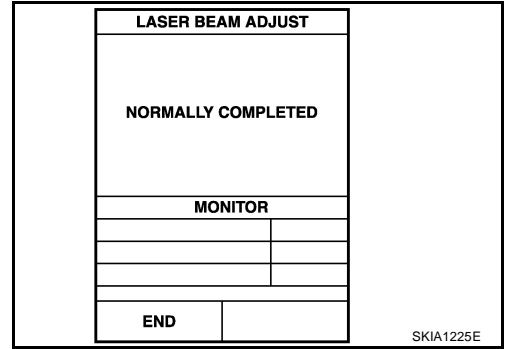

A
B
C
D
E
F
G
H
I
J
L
M

CHECK AFTER THE ADJUSTMENT

Test the ICC system operation by running test. Refer to [ACS-36, "ICC System Running Test"](#) .

ACS

ELECTRICAL UNITS LOCATION

[ICC]

ELECTRICAL UNITS LOCATION

PFP:25230

Component Parts and Harness Connector Location

EKS003P0

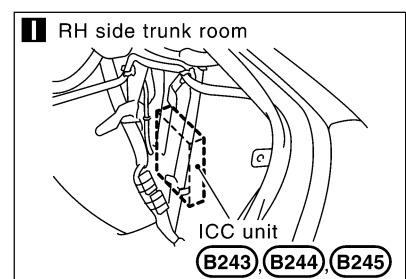
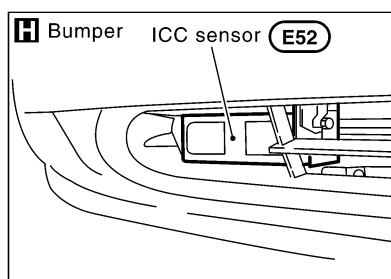
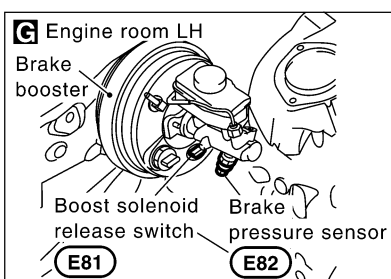
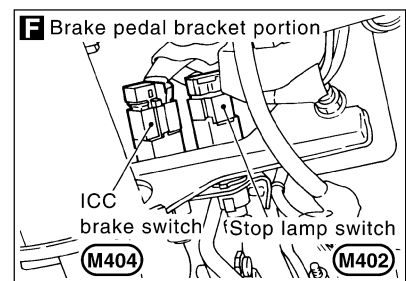
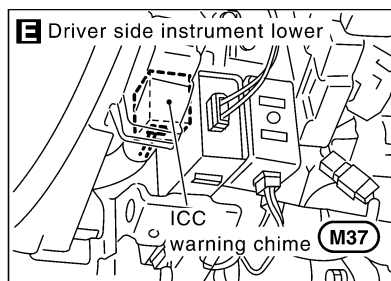
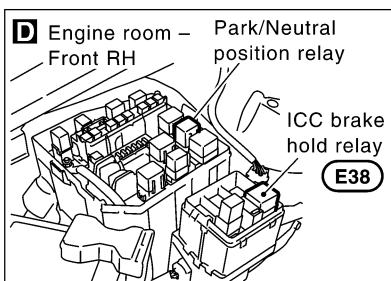
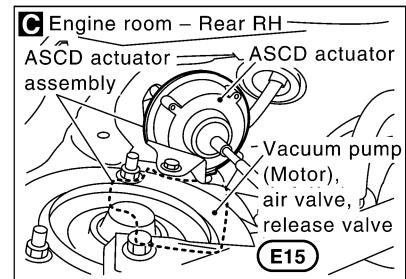
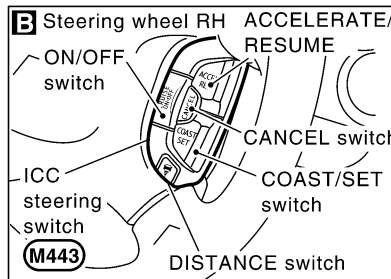
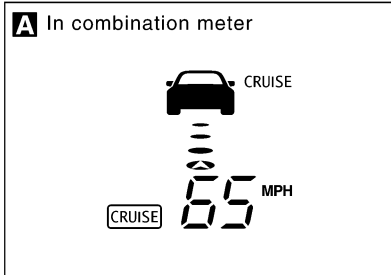
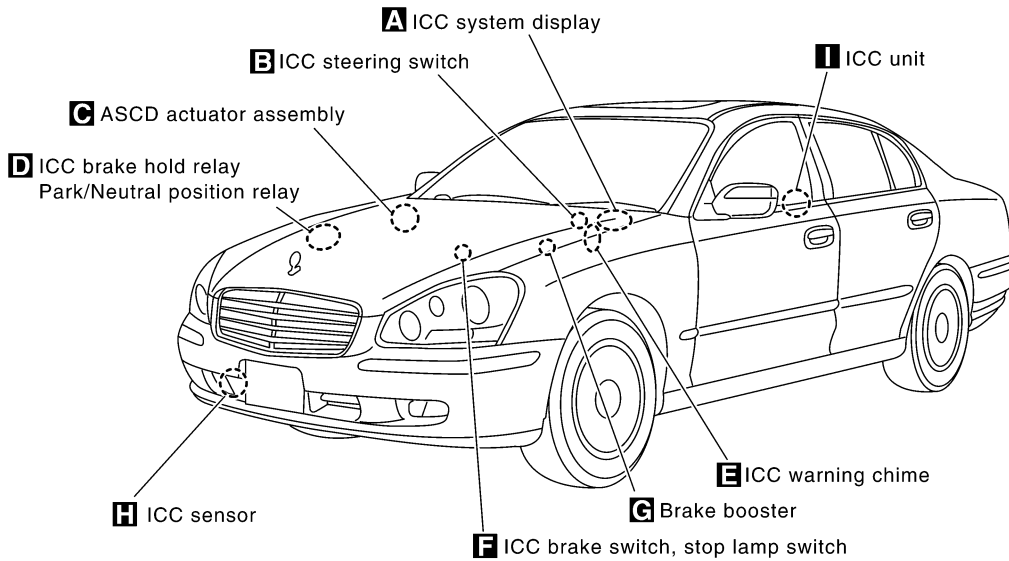

PKIA2300E

WIRING DIAGRAM

[ICC]

WIRING DIAGRAM

Schematic

PFP:00000

EKS003P1

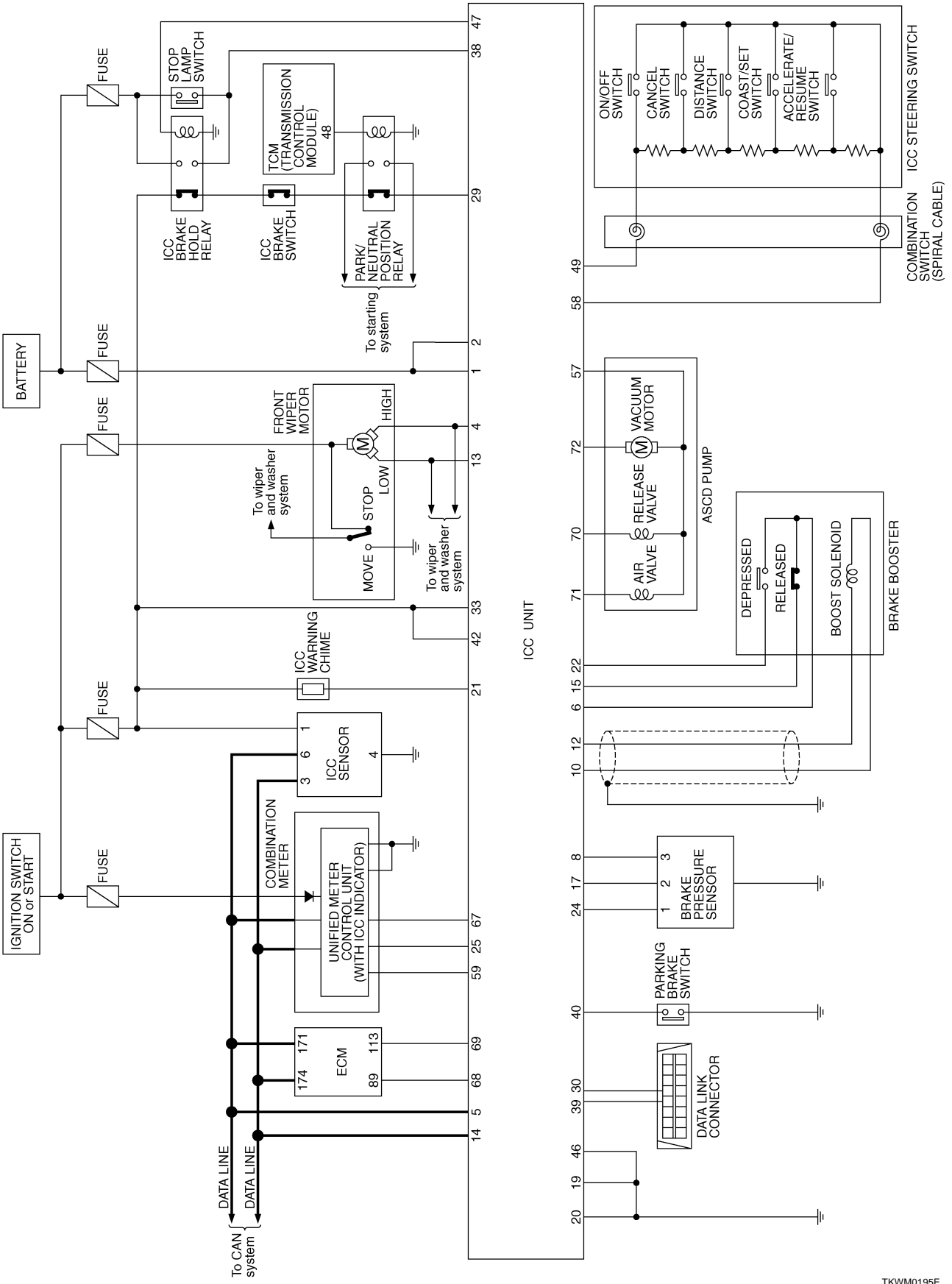

ACS

TKWM0195E

WIRING DIAGRAM

[ICC]

Wiring Diagram — ICC —

EKS003P2

ACS-ICC-01

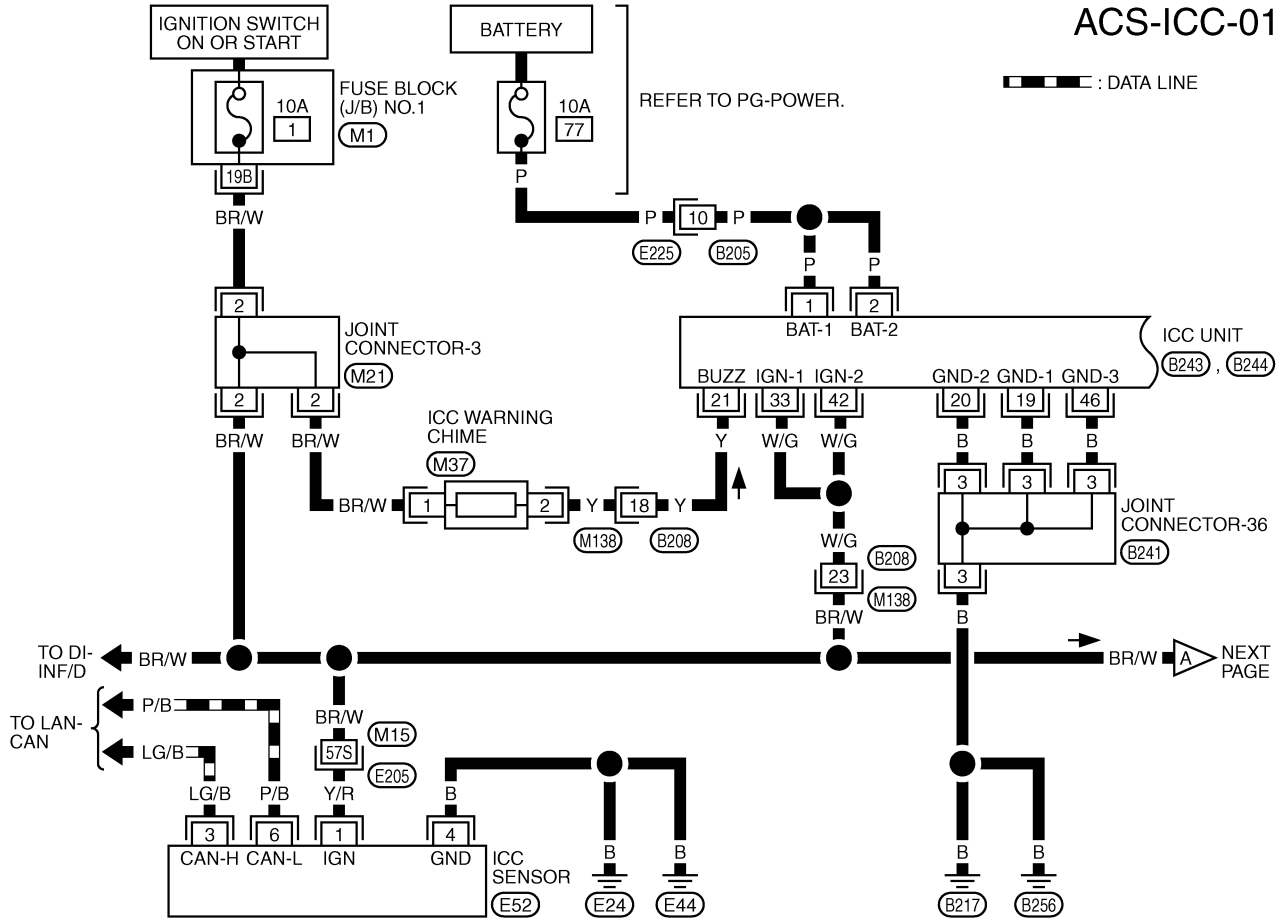

DATA LINE

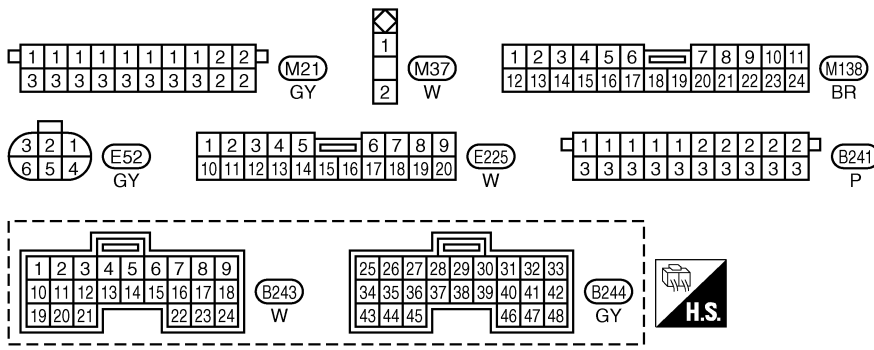

REFER TO THE FOLLOWING.

- (E205) -SUPER MULTIPLE JUNCTION (SMJ)
- (M1) -FUSE BLOCK-JUNCTION BOX (J/B) NO.1



WIRING DIAGRAM

[ICC]

ACS-ICC-02

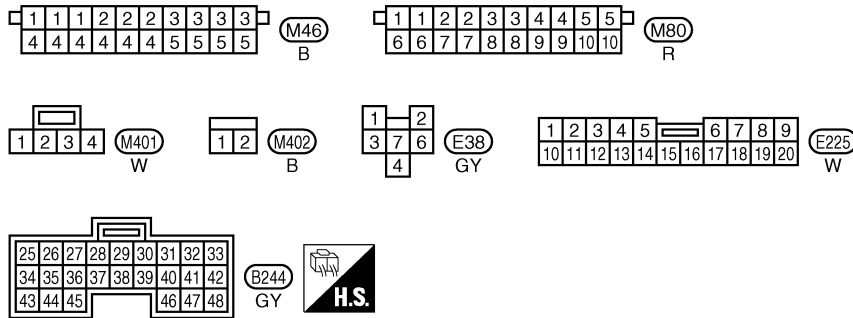
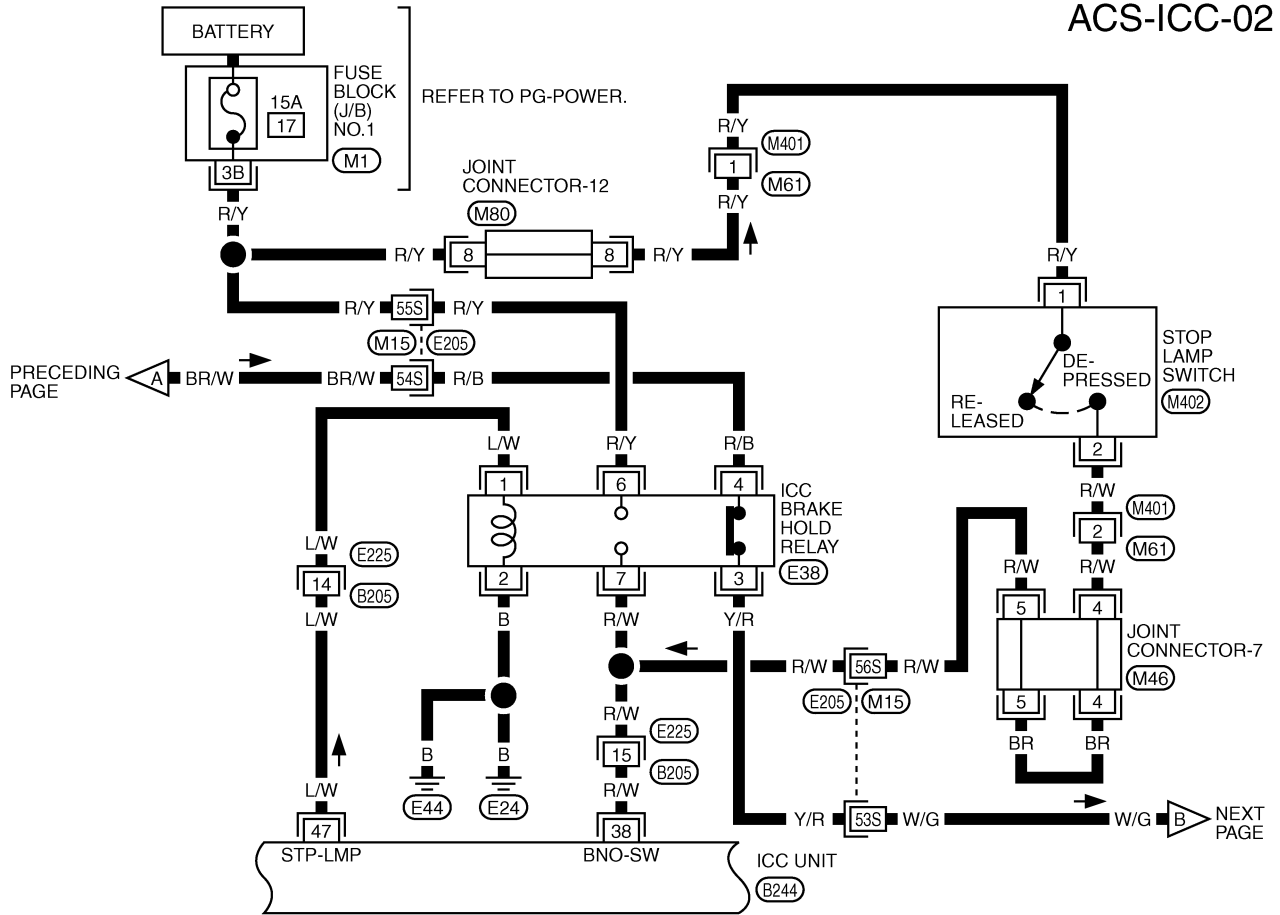

REFER TO THE FOLLOWING.

(E205) -SUPER MULTIPLE JUNCTION (SMJ)

(M1) -FUSE BLOCK-JUNCTION BOX (J/B) NO.1

A
B
C
D
E
F
G
H
I
J
L
M

ACS

WIRING DIAGRAM

[ICC]

ACS-ICC-03

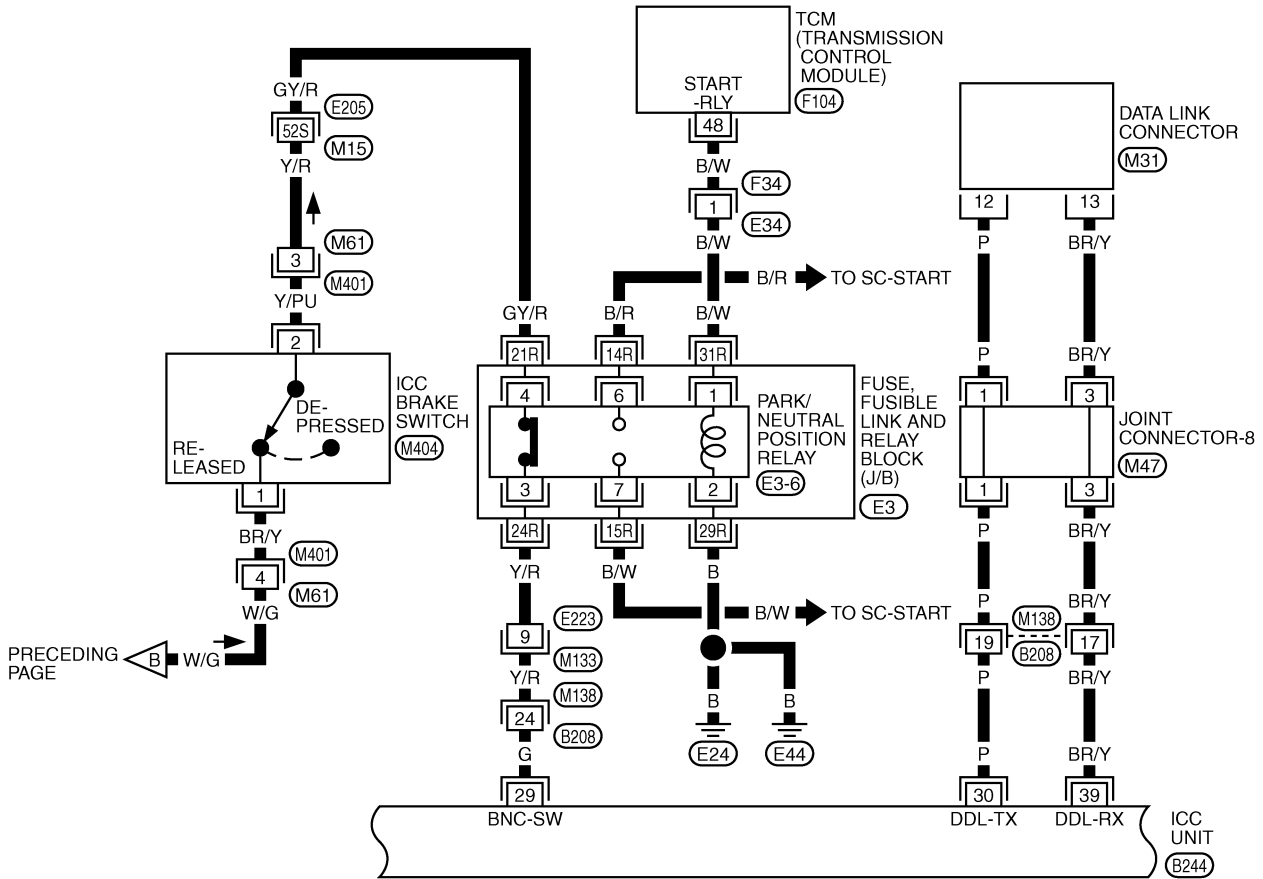

PRECEDING PAGE

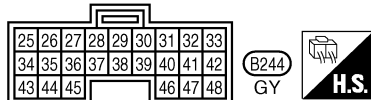
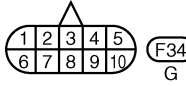
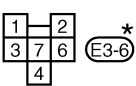
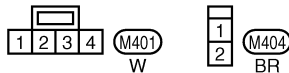
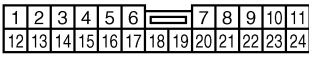
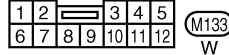
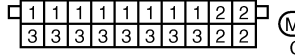
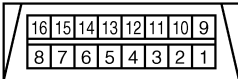

*: THIS CONNECTOR IS NOT SHOWN IN "HARNESS LAYOUT", PG SECTION.

REFER TO THE FOLLOWING.

- (E205) -SUPER MULTIPLE JUNCTION (SMJ)
- (E3) -FUSE, FUSIBLE LINK AND RELAY BLOCK (J/B)
- (F104) -ELECTRICAL UNITS

TKWM0447E

WIRING DIAGRAM

[ICC]

ACS-ICC-04

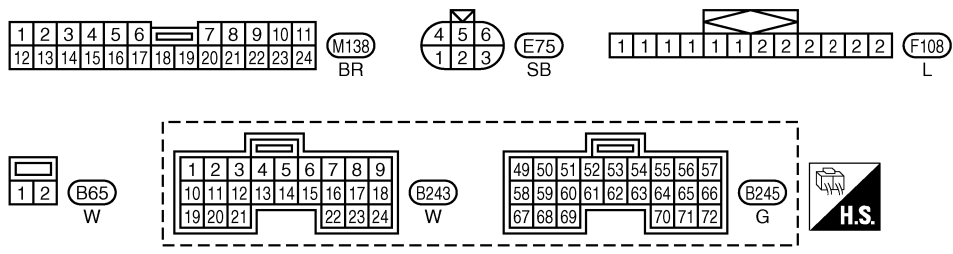
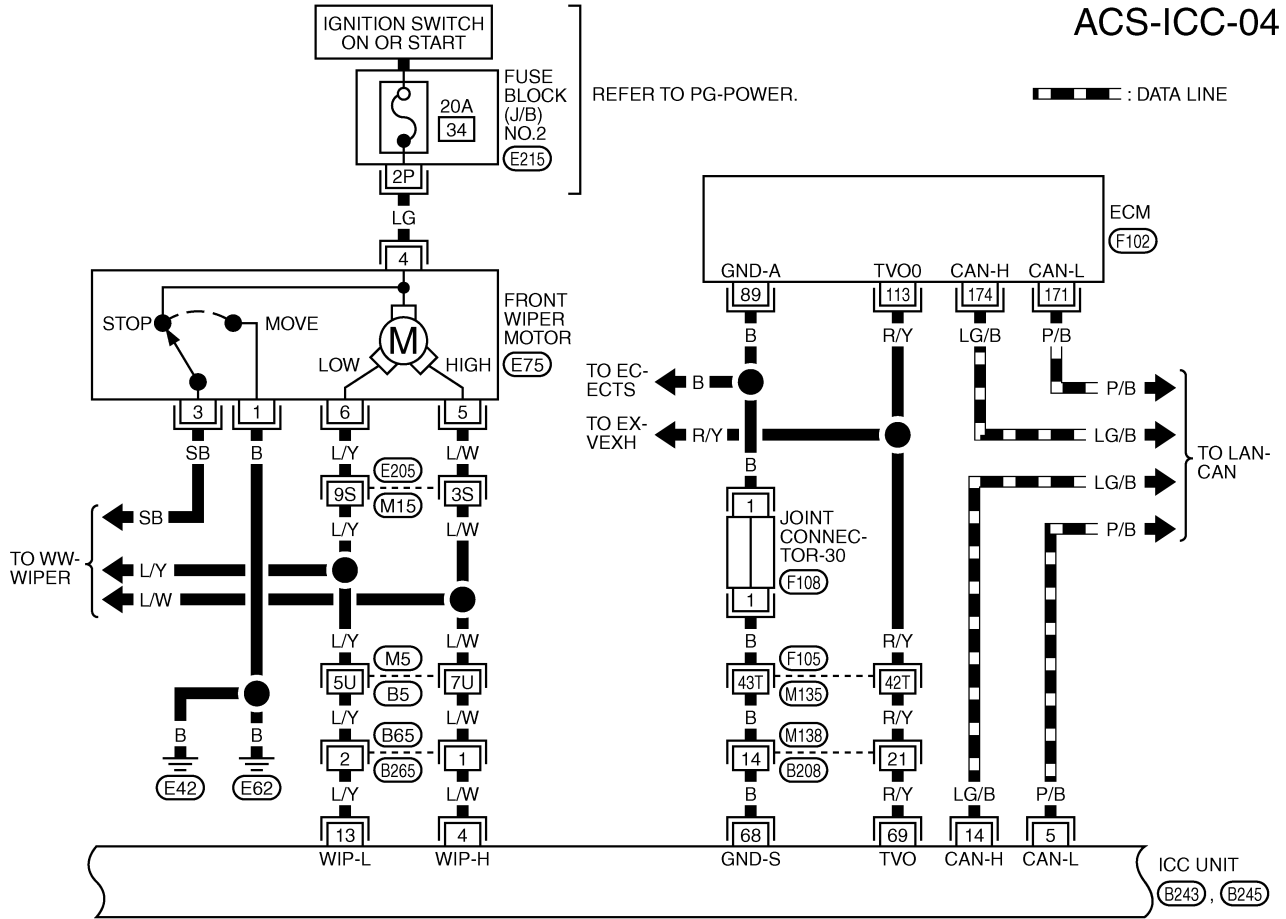

REFER TO THE FOLLOWING.

(M5), (E205), (F105) -SUPER MULTIPLE JUNCTION (SMJ)

(E215) -FUSE BLOCK-JUNCTION BOX (J/B) NO.2

(F102) -ELECTRICAL UNITS

A

B

C

D

E

F

G

H

I

J

ACS

L

M

WIRING DIAGRAM

[ICC]

ACS-ICC-06

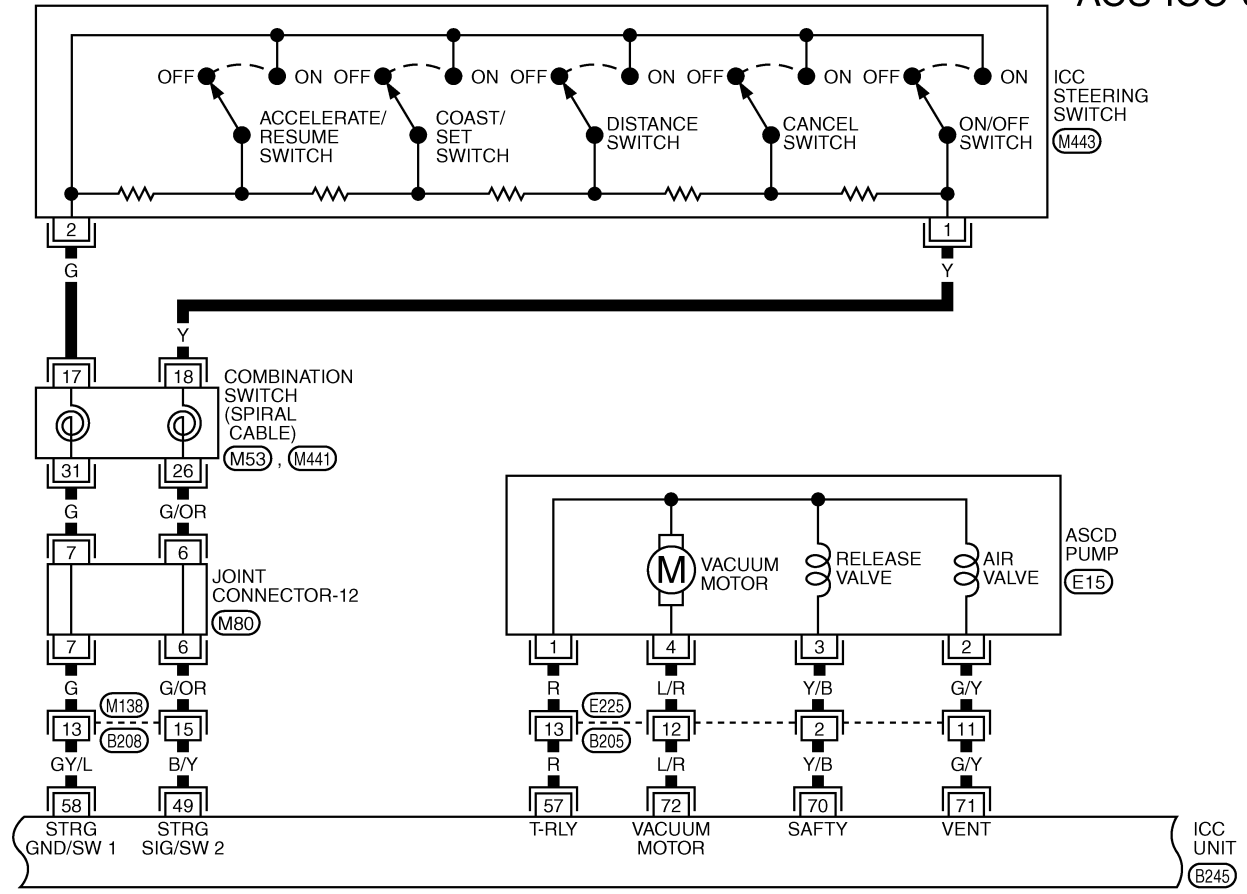

A
B
C
D
E
F
G
H
I
J
L
M

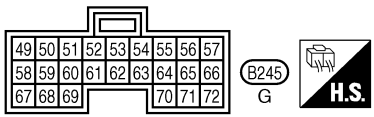
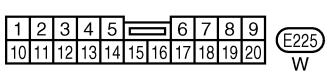
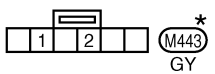
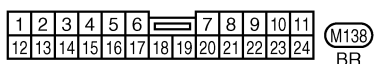
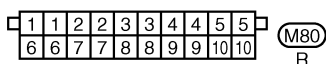
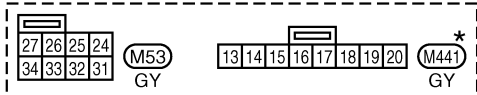

*: THIS CONNECTOR IS NOT SHOWN IN "HARNESS LAYOUT", PG SECTION.

ACS

WIRING DIAGRAM

[ICC]

ACS-ICC-07

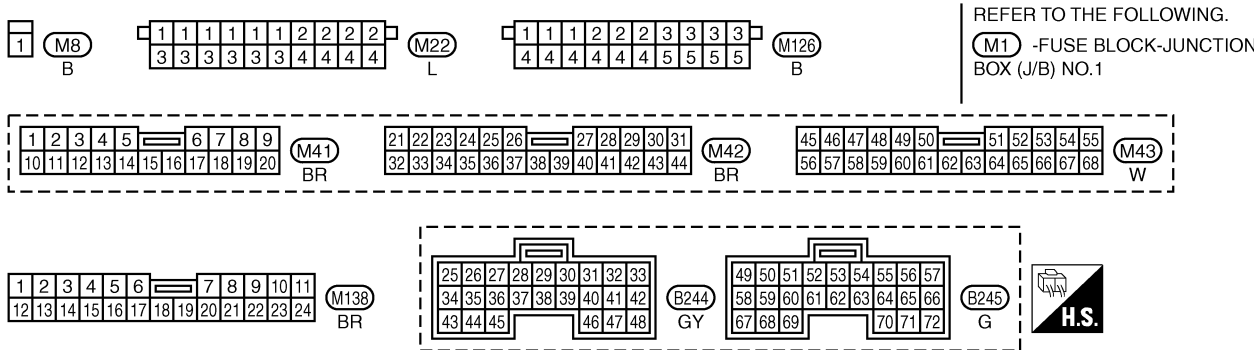
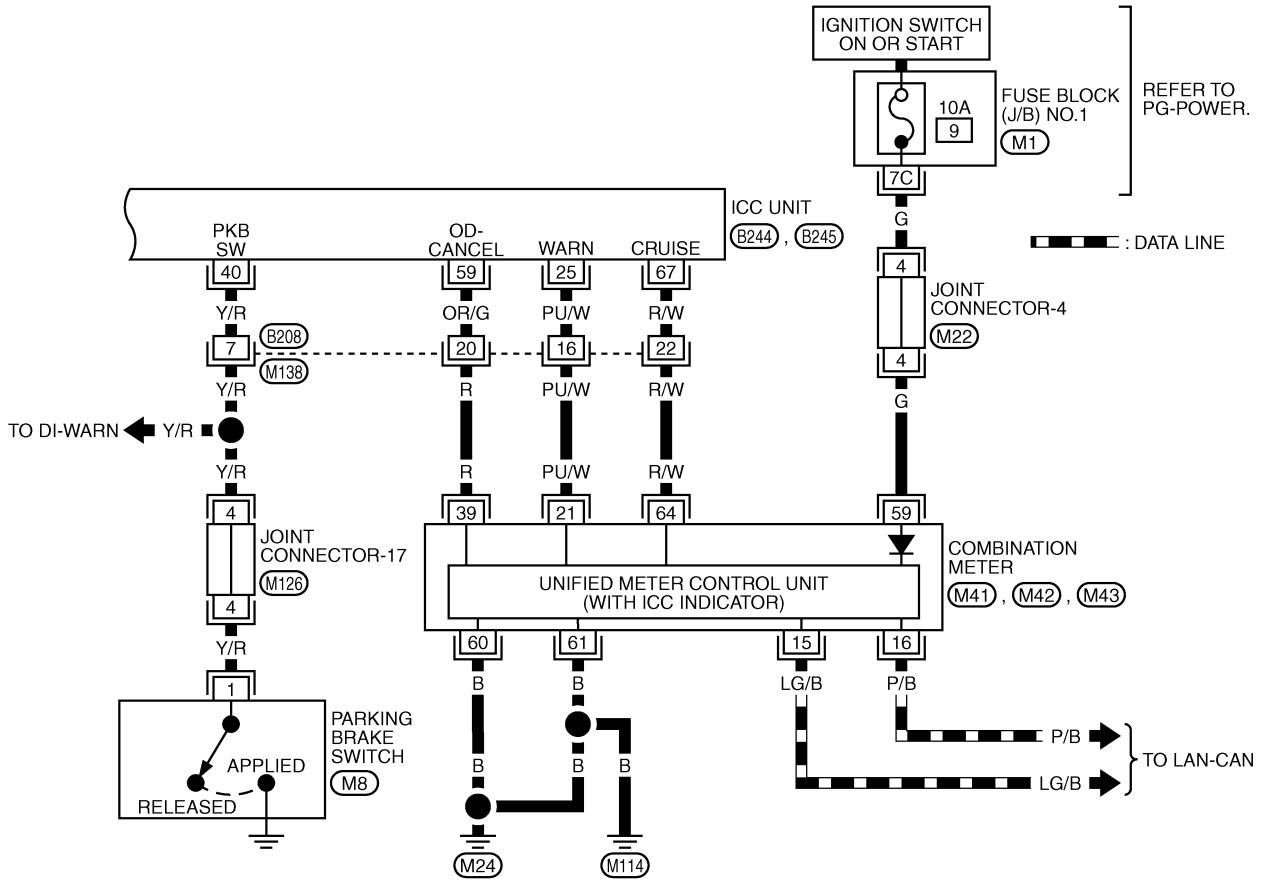

TKWM0449E

TERMINALS AND REFERENCE VALUE



[ICC]

TERMINALS AND REFERENCE VALUE

PFP:00000

Terminals and Reference Value for ICC Unit

EKS003P3

TERMINALS (WIRE COLOR)		ITEM	CONDITION		VOLTAGE (V)
+	-		IGNI- TION SWITCH	OPERATION	
1(P) 2(P)		Battery power supply	OFF	—	Power supply voltage (Approx. 12)
4 (L/W)	Ground	Wiper motor HI signal	ON	Wiper HI operating	Approx. 0
				Wiper HI not operating	Power supply voltage (Approx. 12)
5 (P/B)		CAN L	ON	—	—
6 (L)		Release switch power supply	ON	—	Approx. 10
8 (PU)	24 (OR)	Brake pressure sensor power supply	ON	—	Approx. 5
10 (W/R)	Ground	Brake booster solenoid (+) side	ON	—	Approx. 12V Approx. 5V 
		Brake booster solenoid (-) side	ON	—	Approx. 12V Approx. 5V 
12 (B/R)		Brake booster solenoid (-) side	ON	—	Approx. 12V Approx. 5V 
		Wiper motor LO signal	ON	Wiper LO operating	Approx. 0
13 (L/Y)	Ground	Wiper motor LO signal	ON	Wiper LO not operating	Power supply voltage (Approx. 12)
14 (LG/B)				CAN H	ON
15 (P)		Brake release switch (normal closed)	ON	Depress the brake pedal.	Approx. 0
				Release the brake pedal.	Approx. 10
17 (B/Y)	24 (OR)	Brake pressure sensor signal	ON	Release the brake pedal.	Approx. 0.5
				Depress the brake pedal.	Approx. 0.5 - 5 (Note) Voltage becomes higher depending on effectiveness of depressing brakes.
19(G) 20(B) 46(B)	Ground	Ground	ON	—	Approx. 0
21(Y)		ICC warning chime	ON	Activated	Approx. 0 - 12
				Not activated	Approx. 12
22 (R/B)	Brake release switch (normally open)	ON	Depress the brake pedal.	Approx. 10	
			Release the brake pedal.	Approx. 0	

A
B
C
D
E
F
G
H
I
J
L
M

ACS

TERMINALS AND REFERENCE VALUE

[ICC]

TERMINALS (WIRE COLOR)		ITEM	CONDITION		VOLTAGE (V)		
+	-		IGNI- TION SWITCH	OPERATION			
25 (PU/ W)	Ground	ICC system warning lamp signal	ON	When warning lamp is ON		Approx. 0	
				When warning lamp is OFF		Power supply voltage (Approx. 12)	
29(G)		ICC brake switch (normal closed)	ON	Selector lever: Not in "N" or "P" position	Depress the brake pedal.		Approx. 0
					Release the brake pedal.		Power supply voltage (Approx. 12)
33(W /G) 42(W /G)		Ignition switch ON or START	ON	—		Battery voltage (Approx.12)	
38 (R/W)				Stop lamp switch (normally open)	ON	Depress the brake pedal.	
		Release the brake pedal.				Approx. 0	
40 (Y/R)		Parking brake signal	ON	Parking brake is ON		Power supply voltage (Approx. 12)	
				Parking brake is OFF		Approx. 0	
47 (L/W)		Stop lamp drive output signal	ON	Brake operating with ICC system		Battery voltage (Approx.12)	
	Brake not operating with ICC sys- tem			Approx. 0			
49 (B/Y)	58 (GY/L)	ICC steering switch signal	ON	When ON/OFF switch is pressed		Approx. 0	
				When CANCEL switch is pressed		Approx. 1.1	
				When DISTANCE adjusting switch is pressed		Approx. 2.1	
				When COAST/SET switch is pressed		Approx. 2.9	
				When ACCELERATE/RESUME switch is pressed		Approx. 3.6	
				When no switch is pressed		Approx. 4.2	
57(R)	Ground	Vacuum motor/air valve/ release valve output signal	ON	Being controlled		Power supply voltage (Approx. 12)	
59 (OR/ G)		A/T OD cancel signal	ON	When O/D is canceled		Approx. 2 or less	
				O/D		Approx. 5 - 10	
67 (R/W)		Cruise output signal	ON	Being controlled		Approx. 8	
	Not controlled			Approx. 0			
69 (R/Y)	68 (B)	Throttle opening angle signal	ON	When accelerator pedal is fully released		Approx. 0.5	
				When accelerator pedal is fully depressed		Approx. 4.0	
70 (Y/B)	Ground	Release valve signal	ON	When motor is not driving		Power supply voltage (Approx. 12)	
				When motor is driving		Approx. 0	
71 (G/Y)	Air valve signal	ON	When motor is not driving		Power supply voltage (Approx. 12)		
			When motor is driving		Approx. 0		

TERMINALS AND REFERENCE VALUE

[ICC]

TERMINALS (WIRE COLOR)		ITEM	CONDITION		VOLTAGE (V)
+	-		IGNI- TION SWITCH	OPERATION	
72 (L/R)	Ground	Vacuum motor signal	ON	When motor is not driving	Power supply voltage (Approx. 12)
				When motor is driving	Approx. 0

A
B
C

Terminals and Reference Value for ICC Sensor

EKS003P4

TERMINALS (WIRE COLOR)		ITEM	CONDITION		VOLTAGE (V)
+	-		IGNI- TION SWITCH	OPERATION	
1 (Y/R)	Ground	ICC sensor power	ON	—	Battery voltage (Approx.12)
3 (LG/B)		CAN H	ON	—	—
6 (P/B)		CAN L	ON	—	—
4(B)		Ground	ON	—	Approx. 0

D
E
F
G
H

Terminals and Reference Value for ICC Warning Chime

EKS003P5

TERMI- NALS (WIRE COLOR)	ITEM	CONDITION		VOLTAGE(V)
		IGNI- TION SWITCH	OPERATION	
1 (BR/W)	Ignition switch ON or START	ON	—	Power supply voltage (Approx. 12)
2 (Y)	ICC warning signal	ON	Chime output OFF	Approx. 12
			Chime output ON	Approx. 0 - 12

ACS

L
M

TROUBLE DIAGNOSIS — GENERAL DESCRIPTION

PFP:00004

Work Flow

EKS003RG

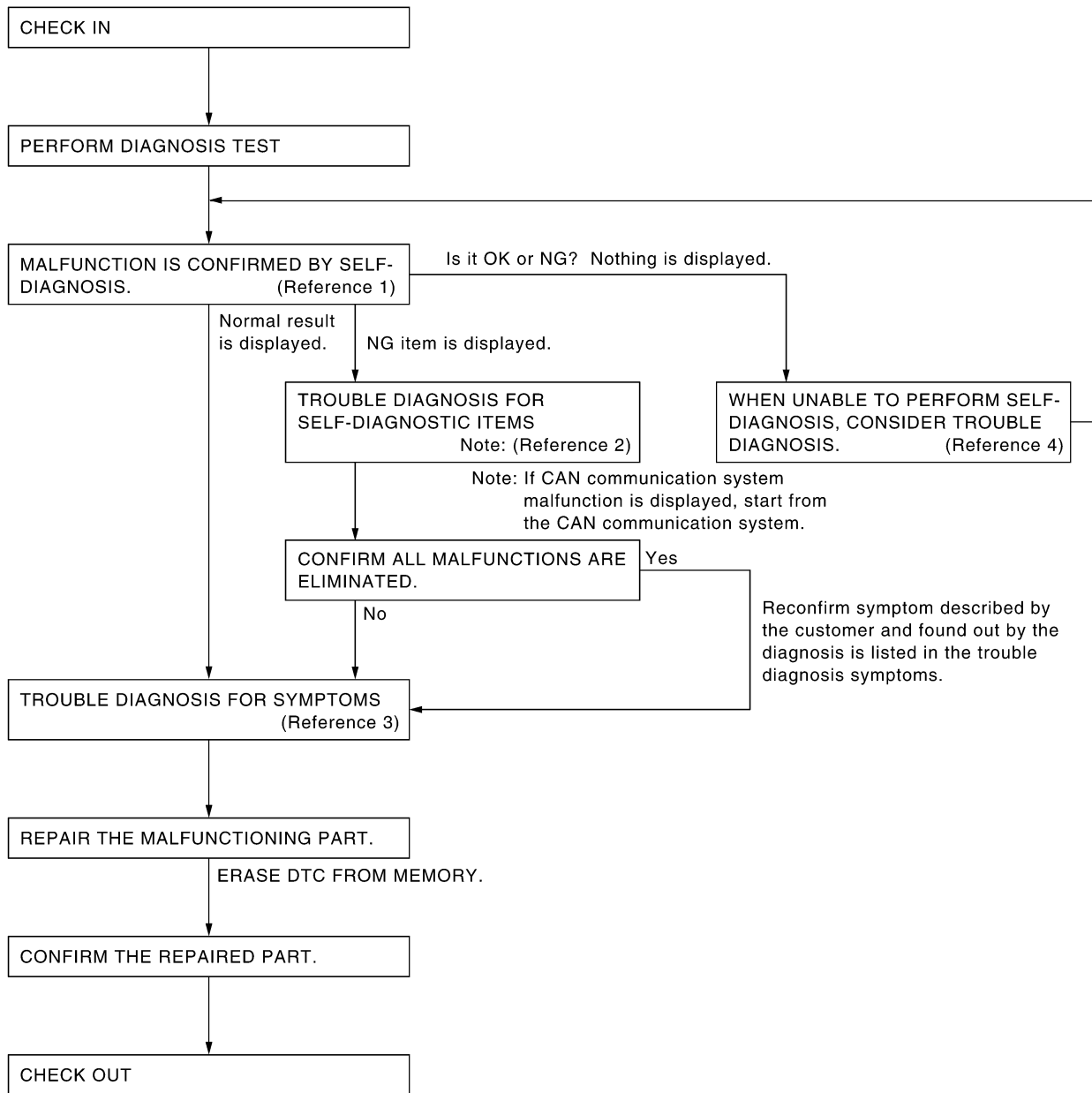

SKIA1227E

- Reference 1... Refer to [ACS-61, "Self-Diagnostic Function"](#) .
- Reference 2... Refer to [ACS-66, "Diagnostic Trouble Code \(DTC\) Chart"](#) .
- Reference 3... Refer to [ACS-90, "Symptom Chart"](#) .
- Reference 4...Refer to [ACS-63, "SELF-DIAGNOSIS BY CONSULT-II WILL NOT RUN"](#) /[ACS-64, "SELF-DIAGNOSIS BY ICC SYSTEM DISPLAY WILL NOT RUN."](#) .

CONSULT-II Function DESCRIPTION

CONSULT-II executes following functions by combining data reception and command transmission via communication line from ICC unit.

Test mode	Function
WORK SUPPORT	<ul style="list-style-type: none"> Monitors aiming direction to facilitate laser beam aiming operation. Indicates causes of automatic cancellation of the ICC system.
SELF-DIAGNOSTIC RESULTS	Displays malfunctioning system memorized in ICC unit.
DATA MONITOR	Displays real-time input/output data of ICC unit.
CAN DIAG SUPPORT MNTR	The results of transmit/receive diagnosis of CAN communication can be read.
ACTIVE TEST	Enables operation check of electrical loads by sending driving signal to them.
ECU PART NUMBER	Displays part number of ICC unit.

WORK SUPPORT

Work Item

Operation	Function
LASER BEAM ADJUST	Outputs laser beam, calculates dislocation of the beam, and indicates adjustment direction.
CAUSE OF AUTO-CANCEL	Indicates causes of automatic cancellation of the ICC system.

Laser Beam Adjust

For details, refer to [ACS-38, "LASER BEAM AIMING ADJUSTMENT"](#) .

Cause of Auto-Cancel

- Turn ignition switch OFF.
- Connect CONSULT-II and CONSULT-II CONVERTER to data link connector.
- Turn ignition switch ON.
- Touch "START" on the display.
- Touch "ICC" on the selection screen.
If "ICC" is not indicated, go to [GI-38, "CONSULT-II Data Link Connector \(DLC\) Circuit"](#) .
- Touch "WORK SUPPORT" on the selection screen.
- Touch "CAUSE OF AUTO-CANCEL" on the selection screen.
- Cause of automatic cancellation screen will be shown.

CAUTION:

Last five cancel (system cancel) causes are displayed.

Display Item List

Cause of cancellation	Description
OPERATING WIPER	Windshield wipers were operated at HI or LO speed and the fastest position of intermittent operation.
OPERATING ABS	ABS was operated.
OPERATING TCS	TCS was operated.
OPERATING VDC	VDC was operated.
OPE SW VOLT CIRC	Outside the standard control switch input voltage was detected.
LASER SUN BEAM	Intense light such as sunlight entered ICC sensor light sensing part.
LASER TEMP	Temperature around ICC sensor became low.
OP SW DOUBLE TOUCH	ICC steering switches were pressed at the same time.
VDC/TCS OFF SW	VDC OFF switch was pressed.
WHEEL SPD UNMATCH	Wheel speed became different from AT vehicle speed.
TIRE SLIP	Wheel slipped.
PKB SW ON	Parking brake is applied.
IGN LOW VOLT	Power supply voltage became low.
NO RECORD	—

SELF-DIAGNOSTIC RESULTS

For details, refer to [ACS-66, "Diagnostic Trouble Code \(DTC\) Chart"](#) .

DATA MONITOR

- Turn ignition switch OFF.
- Connect CONSULT-II and CONSULT-II CONVERTER to data link connector.
- Turn ignition switch ON.
- Touch "START" on the display.
- Touch "ICC" on the selection screen.
If "ICC" is not indicated, go to [GI-38, "CONSULT-II Data Link Connector \(DLC\) Circuit"](#) .
- Touch "DATA MONITOR" on the selection screen.
- Touch any of "ECU INPUT SIGNALS", "MAIN SIGNALS", and "SELECTION FROM MENU" on selection screen.
- Touch "SETTING".
- Display the data monitor.
- If necessary, touch "PRINT" in turn, and print data.

Monitored Item

× : Applicable

Monitored Item [unit]	MAIN SIGNALS	ECU INPUT SIGNALS	SELECTION FROM MENU	Description
VHCL SPEED SE [km/h] or [mph]	×	×	×	Indicates vehicle speed calculated from wheel speed sensor signal.
SET VHCL SPD [km/h] or [mph]	×		×	Indicates set vehicle speed memorized in ICC unit.
THRTL SENSOR [deg]	×	×	×	Indicates throttle angle calculated from signal voltage of throttle position sensor.
VACUUM PUMP [msec]	×		×	Indicates vacuum pump driving pulse width
AIR VALVE [msec]	×		×	Indicates air valve driving pulse width

TROUBLE DIAGNOSIS — GENERAL DESCRIPTION

[ICC]

Monitored Item [unit]	MAIN SIGNALS	ECU INPUT SIGNALS	SELECTION FROM MENU	Description
ENGINE RPM [rpm]		×	×	Indicates engine speed read by ICC unit via CAN communication (ECM transmits engine speed via CAN communication).
DISTANCE ADJ [SHOR/MID/LONG]	×	×	×	Indicates set distance memorized in ICC unit.
WIPER SW [OFF/LOW/HIGH]		×	×	Indicates wiper [OFF/LOW/HIGH] status.
MAIN SW [ON/OFF]	×	×	×	Indicates [ON/OFF] status as judged from control switch signal.
SET/COAST SW [ON/OFF]	×	×	×	Indicates [ON/OFF] status as judged from control switch signal.
CANCEL SW [ON/OFF]	×	×	×	Indicates [ON/OFF] status as judged from control switch signal.
RESUME/ACC SW [ON/OFF]	×	×	×	Indicates [ON/OFF] status as judged from control switch signal.
CRUISE OPE [ON/OFF]	×		×	Indicates whether controlling or not (ON means “controlling”).
BRAKE SW [ON/OFF]	×	×	×	Indicates [ON/OFF] status as judged from ICC brake switch signal.
STOP LAMP SW [ON/OFF]	×	×	×	Indicates [ON/OFF] status as judged from stop lamp switch signal.
RELEASE SW NO [ON/OFF]		×	×	Indicates [ON/OFF] status as judged from release switch signal. ON when brake is depressed. OFF when brake is not depressed.
RELEASE SW NC [ON/OFF]		×	×	Indicates [ON/OFF] status as judged from release switch signal. OFF when brake is depressed. ON when brake is not depressed.
IDLE SW [ON/OFF]		×	×	Indicates [ON/OFF] status of idle switch read by ICC unit via CAN communication (ECM transmits ON/OFF status via CAN communication).
GEAR [1, 2, 3, 4, 5]		×	×	Indicates AT gear position read by ICC unit via CAN communication (TCM transmits gear position via CAN communication).
CRUISE SIGNAL [ON/OFF]			×	Indicates whether controlling or not (ON means “controlling”).
BUZZER O/P (ON/OFF)			×	Indicates [ON/OFF] status of ICC war output.
ICC WARNING [ON/OFF]			×	Indicates [ON/OFF] status of ICC system warning lamp.
VHCL SPD AT [km/h] or [mph]			×	Indicates vehicle speed calculated from AT vehicle speed sensor by ICC unit via CAN communication (TCM transmits AT vehicle speed sensor signal via CAN communication).
PRESS SENS [bar]	×	×	×	Indicates brake fluid pressure value calculated from signal voltage of pressure sensor.
D RANGE SW [ON/OFF]		×	×	Indicates [ON/OFF] status of “D” position read by ICC unit via CAN communication (TCM transmits ON/OFF condition of “D” position via CAN communication).
AT OD OFF [ON/OFF]			×	Indicates [ON/OFF] status of OD cancel output under control.

A
B
C
D
E
F
G
H
I
J
L
M

ACS

Monitored Item [unit]	MAIN SIGNALS	ECU INPUT SIGNALS	SELECTION FROM MENU	Description
NP RANGE SW (ON /OFF)		×	×	Indicates PNP switch signal read by ICC unit via CAN communication. TCM transmits PNP switch signal via CAN communication.
STP LMP DRIVE [ON/OFF]	×		×	Indicates [ON/OFF] status of brake hold relay drive output.

ACTIVE TEST

Caution

- Do not perform the active test while driving.
 - Active test cannot be started while ICC system warning indicator illuminates.
1. Turn ignition switch OFF.
 2. Connect CONSULT-II and CONSULT-II CONVERTER to data link connector and start engine.
 3. Touch “START”, “ICC”, and “ACTIVE TEST” on CONSULT-II display in turn.
If “ICC” is not indicated, go to [GI-38, "CONSULT-II Data Link Connector \(DLC\) Circuit"](#) .
 4. Touch necessary test item.
 5. Touch “START”.
 6. Active test screen will be shown.

ICC Buzzer 1

- Touch “ON” and “OFF” to check that ICC warning chime operates as in the following chart.

BUZZER O/P	ON	OFF
Buzzer sound	Beep	Not activated

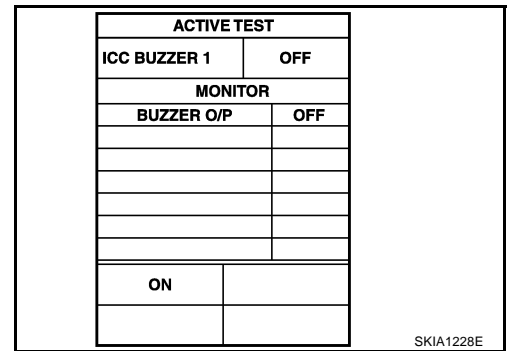

ICC Warning Lamp

- Touch “ON” and “OFF” to check that ICC warning lamp operates as in the following chart.

ICC WARNING LAMP	ON	OFF
ICC system warning lamp (Orange)	Lamp ON	Lamp OFF

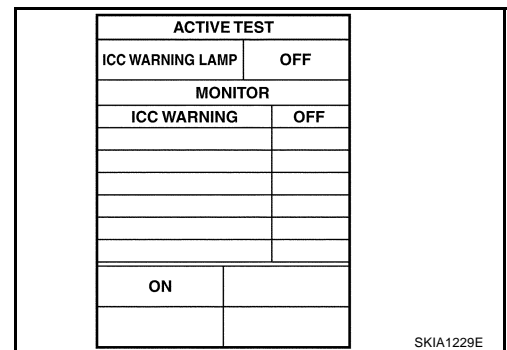

Meter Lamp

- Start engine.

CAUTION:

If “ICC” cannot be shown after several attempts, the ICC unit may have had malfunction. Repair or replace it. Refer to [ACS-63, "SELF-DIAGNOSIS BY CONSULT-II WILL NOT RUN"](#) .

4. Self-diagnostic result appears on screen. If “NO DTC ...” is shown, check ICC warning lamp. If any malfunction is indicated, GO TO step 5.
5. According to [ACS-66, "Diagnostic Trouble Code \(DTC\) Chart"](#) , perform appropriate check, and repair or replace malfunctioning part as necessary.
6. Turn ignition switch OFF.
7. Start engine and touch “START”, “ICC”, “SELF-DIAG RESULT”, and “ERASE” on CONSULT-II display in turn to erase the memory.

CAUTION:

If the memory does not erase, go to 5.

8. Perform ICC system running test (drive vehicle with ICC system ON), and make sure that ICC warning lamp does not illuminate.

WITHOUT CONSULT-II

1. Go to operation check after asking the customer for symptom information. Refer to [ACS-36, "ACTION TEST"](#) .
2. Stop the vehicle to start the self-diagnosis.
3. Turn ignition switch OFF.
4. Turn ignition switch ON, and within 5 to 10 seconds, press ACCELERATE/RESUME switch 5 times. Then press COAST/SET switch 5 times to start self-diagnosis.

CAUTION:

- Do not start the engine.
- Do not turn the ON/OFF switch ON.
- When operation above is not completed within 5 to 10 seconds, start again from above go to 3.
- If self-diagnosis mode cannot be start after several attempts, the ICC unit may have had malfunction. Repair or replace it. Refer to [ACS-64, "SELF-DIAGNOSIS BY ICC SYSTEM DISPLAY WILL NOT RUN."](#) .

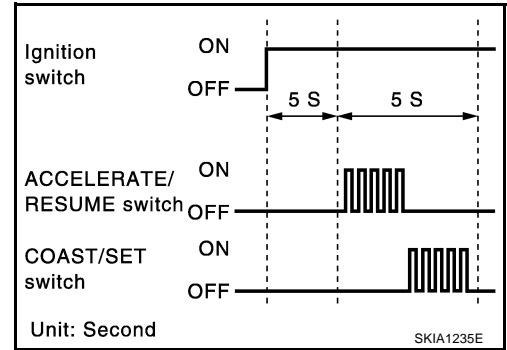

5. When self-diagnosis mode is started, DTCs are shown on set vehicle speed indicator.

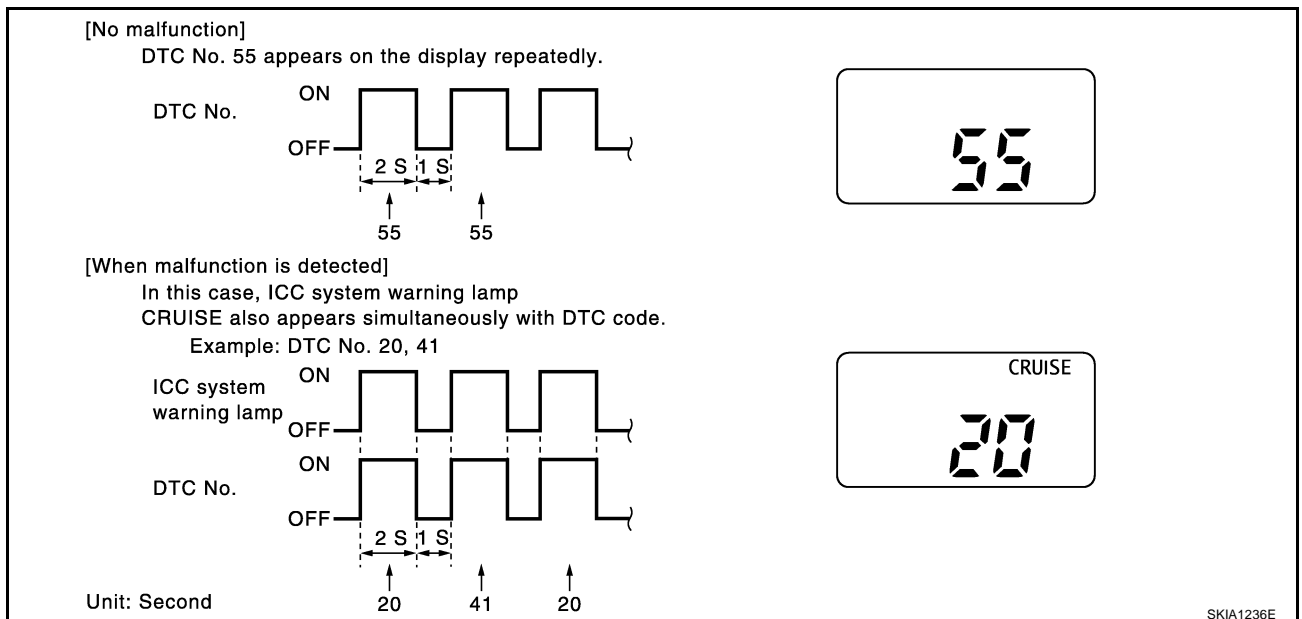

CAUTION:

- DTCs will disappear after 5 minutes.

- When more than one malfunctions are detected, a maximum of 3 code numbers can be stored; the latest malfunction will be displayed first.
6. Check [ACS-66, "Diagnostic Trouble Code \(DTC\) Chart"](#) , and repair or replace if necessary.
 7. After repair, erase DTCs stored in the ICC unit.
 8. DTC 55 will be shown.
 9. Turn ignition switch OFF to exit the diagnosis.
 10. Perform ICC system running test (drive vehicle with ICC system ON), and make sure that ICC warning lamp does not illuminate.

Self-Diagnostic Erasing Method

1. Stop the vehicle and turn the ignition switch OFF.
2. Turn ignition switch ON and start self-diagnosis.
3. During self-diagnosis mode, press CANCEL switch 5 times, and DISTANCE switch 5 times in this order.

CAUTION:

- Press them within 10 seconds after pressing CANCEL switch at first.
- When operation is not completed within 10 seconds, start again from above go to 2.

4. DTC 55 will be shown.

CAUTION:

DTCs of an existing malfunction will not be erased.

5. Turn ignition switch OFF to exit the diagnosis.
6. Perform ICC system running test (drive vehicle with ICC system ON), and make sure that ICC system warning lamp (orange) does not illuminate.

SELF-DIAGNOSIS BY CONSULT-II WILL NOT RUN

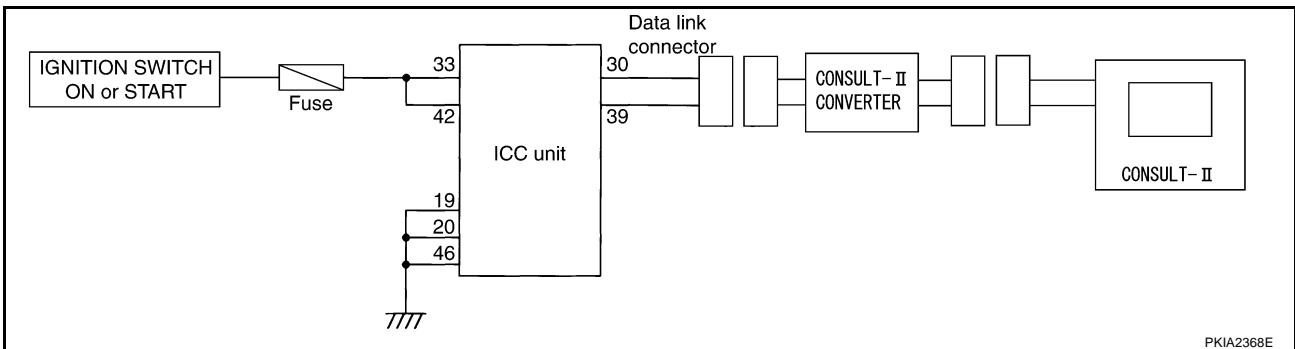

Possible Irregular Condition

Open or short lines	Trouble phenomenon	Malfunction causes
ICC unit power supply malfunction	No voltage supply from ignition switch	Ignition relay malfunctioned
		Fuse blown
		Harness open
	Ground cable not connected	Harness open
Harness shorted		
ICC unit malfunction		

1. CHECK CONSULT-II SYSTEM

- Can CONSULT-II call other systems?

Yes or No

Yes >> GO TO 2.

No >> Check CONSULT-II SYSTEM. Refer to [GI-38, "CONSULT-II Data Link Connector \(DLC\) Circuit"](#) .

2. CHECK POWER SUPPLY FOR ICC UNIT

- Is ICC unit turned ON?

Yes or No

- Yes >> GO TO 3.
- No >> Check power supply system, and repair if necessary.

3. CHECK HARNESS FOR DATA LINK CONNECTOR

- Is continuity between ICC unit and data link connector normal?

Yes or No

- Yes >> GO TO 4.
- No >> Harness repair

4. SELF-DIAGNOSIS CHECK

- Disconnect ICC unit connector, and check terminals for bend and looseness. Securely connect it again.
- Enter self-diagnosis mode?

Yes or No

- Yes >> Inspection is completed.
- No >> ICC unit replacement

SELF-DIAGNOSIS BY ICC SYSTEM DISPLAY WILL NOT RUN.

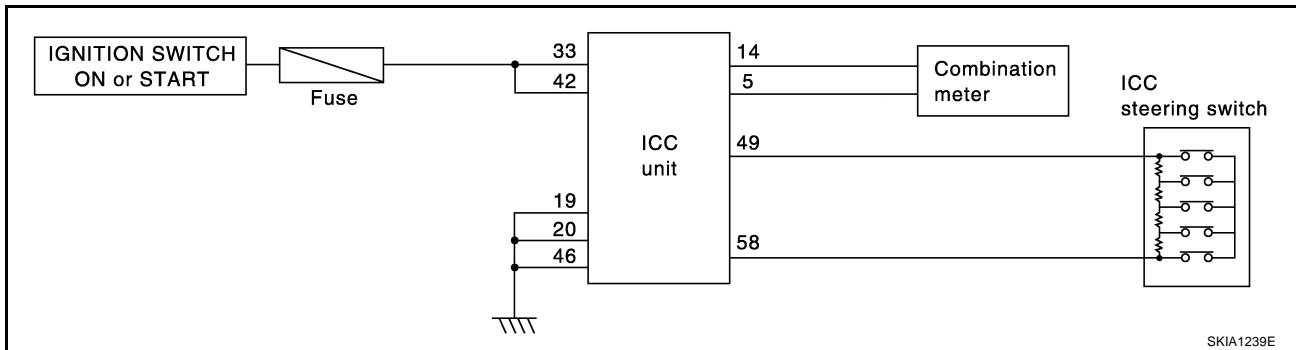

Possible Irregular Condition

Open or short lines	Trouble phenomenon	Malfunction causes
ICC unit power supply malfunction	No voltage supply from ignition switch	Fuse blown Harness open Harness shorted
	Ground cable not connected	Harness open Harness shorted
ICC steering switch malfunction	No signal transmitted	Harness open
		Harness shorted
		Spiral cable open
		Spiral cable shorted
CAN communication system malfunction	Signal not transmitted	Switch malfunction
		Harness open
		Harness shorted CAN communication outside the standard
Combination meter system malfunction	Indication not possible	Indicator malfunction
		Indicator segments disappear.
ICC unit malfunction		

1. CHECK ICC SYSTEM DISPLAY

- When ignition switch is ON, do all displays illuminate?

Yes or No

- Yes >> GO TO 2.
No >> GO TO 5.

2. CHECK ICC STEERING SWITCH

- Check ICC steering switch. Refer to [ACS-99, "ICC Steering Switch"](#) .

OK or NG

- OK >> GO TO 3.
NG >> Replace ICC steering switch.

3. CHECK HARNESS BETWEEN ICC UNIT AND ICC STEERING SWITCH

- Check harness and spiral cable between ICC unit and ICC steering switch for open or short circuit.

OK or NG

- OK >> GO TO 4.
NG >> Replace or replace applicable item.

4. CHECK SELF-DIAGNOSIS

- Disconnect connector of ICC unit, and check terminals for bend and looseness. Securely connect it again.
- Enter self-diagnosis mode?

Yes or No

- Yes >> Inspection is completed.
No >> GO TO 5.

5. CHECK POWER SUPPLY FOR ICC UNIT

- Check ICC unit power supply, and repair if necessary.
- When ignition switch is ON, do all displays illuminate?

Yes or No

- Yes >> Perform self-diagnosis again.
No >> GO TO 6.

6. CHECK CONNECTOR FOR ICC UNIT

- Disconnect connector of ICC unit, and check terminals for bend and looseness. Securely connect it again.
- When ignition switch is ON, do all displays illuminate?

Yes or No

- Yes >> Perform self-diagnosis again.
No >> GO TO 7.

7. CHECK CAN COMMUNICATION

- Perform self-diagnosis with CONSULT-II, and check CAN communication system for malfunction.

OK or NG

- OK >> Replace combination meter.
NG >> CAN communication inspection. Refer to [ACS-68, "DTC 20 CAN COMM CIRCUIT"](#) .

A

B

C

D

E

F

G

H

I

J

ACS

L

M

TROUBLE DIAGNOSIS FOR SELF-DIAGNOSTIC ITEMS

[ICC]

TROUBLE DIAGNOSIS FOR SELF-DIAGNOSTIC ITEMS

PFP:00000

Diagnostic Trouble Code (DTC) Chart

EKS003P9

×:Applicable

DTC No.	CONSULT-II screen terms	ICC system warning lamp	Fail-safe		Malfunctions detected where...	Reference page
			ICC system	Brake assist (with preview function)		
11	CONTROL UNIT	×	×	×	● ICC unit internal malfunction	ACS-68
20	CAN COMM CIRCUIT	×	×	×	● ICC unit detected CAN communication malfunction.	ACS-68
31	POWER SUPPLY CIR1	×	×	×	● ICC unit power supply voltage is excessively low. (less than 8V)	ACS-68
34	POWER SUPPLY CIR2	×	×	×	● ICC unit power supply voltage is excessively high.	ACS-68
41	VHCL SPEED SE CIRC	×	×	×	<ul style="list-style-type: none"> ● Wheel sensor malfunction. ● VDC/TCS/ABS control unit malfunction ● AT vehicle speed sensor malfunction ● TCM malfunction 	ACS-69
42	THRTL POS SEN CIRC	×	×		<ul style="list-style-type: none"> ● Throttle position sensor harness is open or shorted. ● Throttle position sensor input is HI or fixed to LO. ● Closed throttle position switch is ON or stuck to OFF. 	ACS-69
43	ABS/TCS/VDC CIRC	×	×	×	● ABS/TCS/VDC system malfunction	ACS-71
45	BRAKE SW/ STOP L SW	×	×	×	<ul style="list-style-type: none"> ● Brake and stop lamp switch harness is open or shorted. ● Brake and stop lamp switch is ON or stuck to OFF. ● Brake and stop lamp switch is stuck to ON. 	ACS-71
46	OPERATION SW CIRC	×	×		<ul style="list-style-type: none"> ● ICC steering switch harness or spiral cable is open or shorted. ● ICC steering switch malfunction 	ACS-73
61	PRESS SEN CIRCUIT	×	×	×	<ul style="list-style-type: none"> ● Brake pressure sensor harness is open or shorted. ● Brake pressure sensor malfunction ● Brake pressure sensor input circuit malfunction 	ACS-75
62	BOOSTER SOL/V CIRCUIT	×	×	×	<ul style="list-style-type: none"> ● Solenoid harness is open or shorted. ● Solenoid is open. ● Solenoid drive circuit malfunction 	ACS-75
63	RELEASE SW CIRCUIT	×	×	×	<ul style="list-style-type: none"> ● Release switch harness is open or shorted. ● Release switch malfunction ● Release switch input circuit malfunction 	ACS-76
65	PRESSURE CONTROL	×	×	×	● Booster malfunction	ACS-77
74	LASER BEAM OFF CNTR	×	×	×	● Laser beam of ICC sensor is off the aiming point.	ACS-78

TROUBLE DIAGNOSIS FOR SELF-DIAGNOSTIC ITEMS

[ICC]

DTC No.	CONSULT-II screen terms	ICC system warning lamp	Fail-safe		Malfunctions detected where...	Reference page
			ICC system	Brake assist (with preview function)		
81	POWER SUPPLY VALVE [HI VOLTAGE]	×	×		<ul style="list-style-type: none"> ● Power supply relay to vacuum pump, air valve, and release valve in ICC unit is stuck closed. ● Power supply wire to release valve is shorted to power supply. 	ACS-78
82	POWER SUPPLY VALVE [HI VOLTAGE]	×	×		<ul style="list-style-type: none"> ● Vacuum pump drive circuit in ICC unit. 	ICC unit malfunction
83	POWER SUPPLY VALVE [LOW VOLTAGE]	×	×		<ul style="list-style-type: none"> ● Vacuum pump drive circuit in ICC unit is irregular condition. ● Vacuum pump control line is shorted to ground. 	ACS-79
84	AIR VALVE [HI VOLTAGE]	×	×		<ul style="list-style-type: none"> ● Air valve drive circuit in ICC unit is irregular condition. 	ICC unit malfunction
85	AIR VALVE [LOW VOLTAGE]	×	×		<ul style="list-style-type: none"> ● Air valve drive circuit in ICC unit is irregular condition. ● Air valve control line is shorted to ground. 	ACS-80
86	RELEASE VALVE [HI VOLTAGE]	×	×		<ul style="list-style-type: none"> ● Release valve drive circuit in ICC unit is irregular condition. 	ICC unit malfunction
87	RELEASE VALVE [LOW VOLTAGE]	×	×		<ul style="list-style-type: none"> ● Release valve drive circuit in ICC unit is irregular condition. ● Power supply relay to vacuum pump, air valve, and release valve in ICC unit is stuck to OFF. ● Release valve control line is shorted. ● Power supply line to vacuum pump, air valve, and release valve is open. 	ACS-80
90	STOP LAMP RLY FIX	×	×	×	<ul style="list-style-type: none"> ● Normally open terminal of stop lamp relay is stuck. 	ACS-81
92	ECM CIRCUIT	×	×	×	<ul style="list-style-type: none"> ● ECM malfunction ● Throttle position sensor malfunction ● ICC unit malfunction 	ACS-86
97	AT CIRCUIT	×	×		<ul style="list-style-type: none"> ● TCM malfunction 	ACS-86
98	GEAR POSITION	×	×		<ul style="list-style-type: none"> ● TCM malfunction ● AT turbine revolution sensor malfunction ● AT vehicle speed sensor malfunction 	ACS-86
102	RADAR STAIN	×	×	×	<ul style="list-style-type: none"> ● ICC sensor body window has contamination. 	ACS-87
103	LASER SENSOR FAIL	×	×	×	<ul style="list-style-type: none"> ● ICC sensor internal malfunction 	ACS-88
104	LASER AIMING INCMP	×	×	×	<ul style="list-style-type: none"> ● Laser beam aiming of ICC sensor is not adjusted. 	ACS-88

A

B

C

D

E

F

G

H

I

J

ACS

L

M

TROUBLE DIAGNOSIS FOR SELF-DIAGNOSTIC ITEMS

[ICC]

DTC No.	CONSULT-II screen terms	ICC system warning lamp	Fail-safe		Malfunctions detected where...	Reference page
			ICC system	Brake assist (with preview function)		
107	LASER COMM FAIL	×	×	×	● CAN data received by ICC sensor is strange (from ICC unit).	ACS-88
109	LASER HIGH TEMP	×	×	×	● Temperature around ICC sensor is excessively high.	ACS-89

DTC 11 CONTROL UNIT

EKS003PA

1. DIAGNOSTIC CHECK

- Are any items other than "DTC 11 CONTROL UNIT" indicated on self-diagnosis display?

Yes or No

- Yes >> Repair or replace applicable item. Erase DTC and perform ICC system running test. Then perform self-diagnosis of ICC system again.
- No >> Replace ICC unit. Erase DTC and perform ICC system running test. Then perform self-diagnosis of ICC system again.

DTC 20 CAN COMM CIRCUIT

EKS003PB

1. CHECK CAN COMMUNICATION

 With CONSULT-II

- Perform self-diagnosis.
- Print self-diagnostic result.

>> After printing self-diagnostic result, go to "CAN system". Refer to [LAN-21, "CAN Communication Unit"](#).

DTC 31 POWER SUPPLY CIR 1, DTC 34 POWER SUPPLY CIR 2

EKS003PC

1. CHECK CONNECTOR ICC UNIT

- Turn ignition switch OFF.
- Disconnect ICC unit connector, and connect it securely again. Then erase DTC. After that perform self-diagnosis of ICC system again.

OK or NG

- OK >> GO TO 2.
- NG >> ● Poor connector connection
- Check connector. (Check connector housing for disconnected, loose, bent, and collapsed terminals. If any malfunction is detected, repair applicable part.) After repair, erase DTC, and perform ICC running test. Then perform self-diagnosis of ICC system again.

2. CHECK POWER SUPPLY CIRCUIT FOR ICC UNIT

- Turn ignition switch ON.
- Check voltage between ICC unit harness connector B244 terminal 33 (W/G), 42 (W/G) and ground.

Battery voltage should exist. (more than 8V)

OK or NG

- OK >> GO TO 3.
- NG >> ● Repair ICC unit power supply harness.
- After repair, erase DTC and perform ICC system running test. Then, perform self-diagnosis of ICC system again.

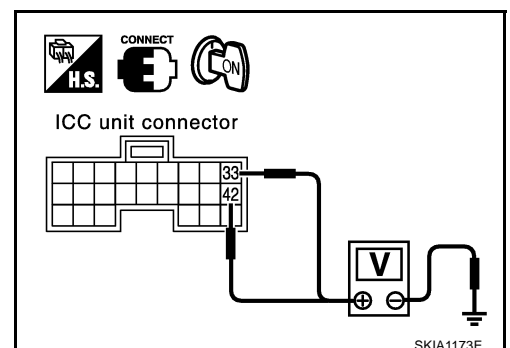

SKIA1173E

3. CHECK GROUND CIRCUIT FOR ICC UNIT

1. Turn ignition switch OFF.
2. Disconnect ICC unit connector.
3. Check continuity between ICC unit harness connector B243 terminal 19 (B), 20 (B), B244 terminal 46 (B) and ground.

Continuity should exist.

OK or NG

OK >> After replacing ICC unit, erase DTC, and perform ICC system running test. Then perform self-diagnosis of ICC system again.

NG >> ● Repair ICC unit ground harness.

- After repair, erase DTC and perform ICC system running test. Then, perform self-diagnosis of ICC system again.

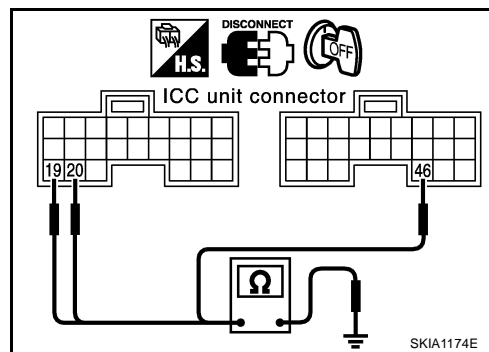

DTC 41 VHCL SPEED SE CIRC

EKS003PD

1. ICC UNIT SELF-DIAGNOSIS CHECK

1. Perform self-diagnosis. Is "DTC 43 ABS/TCS/VDC CIRC" or "DTC 20 COMM CIRCUIT" indicated in self-diagnosis item display?

Yes or No

Yes >> Repair or replace applicable item. Erase DTC and perform ICC system running test. Then perform self-diagnosis of ICC system again.

No >> GO TO 2

2. CHECK AT VEHICLE SPEED SENSOR

With CONSULT-II

- With data monitor, check "VHCL SPD AT" operate normally. Refer to [ACS-58, "DATA MONITOR"](#).

OK or NG

OK >> Replace ICC unit. Erase DTC and perform ICC system running test. Then perform self-diagnosis of ICC system again.

NG >> ● Check TCM.

- After repair, erase DTC and perform ICC system running test. Then, perform self-diagnosis of ICC system again.

DTC 42 THRTL POS SEN CIRC

EKS005QC

1. CHECK CONNECTOR FOR ICC UNIT

1. Turn ignition switch OFF.
2. Disconnect ICC unit connector, and connect it securely again. Then erase DTC. After that perform self-diagnosis of ICC system again.

OK or NG

OK >> ● Poor connector connection

- Check connector. (Check connector housing for disconnected, loose, bent, and collapsed terminals. If any malfunction is detected, repair applicable part.) After repair, erase DTC, and perform ICC system running test. Then perform self-diagnosis of ICC system again.

NG >> GO TO 2.

2. CHECK THROTTLE POSITION SENSOR AND IDLE SWITCH

With CONSULT-II

- With data monitor, check that "THRTL SENSOR" and "IDLE SW" switches operate normally. Refer to [ACS-58, "DATA MONITOR"](#).

OK or NG

- OK >> Replace ICC unit. Erase DTC and perform ICC system running test. Then perform self-diagnosis of ICC system again.
- NG >> GO TO 3.

3. CHECK THROTTLE POSITION SIGNAL FOR ICC UNIT

- Check voltage between ICC unit harness connector B245 terminal 69 (R/Y) and 68 (B).

Approx 0.5V (Throttle full closed)

Approx 4.0V (Throttle full open)

OK or NG

- OK >> GO TO 5.
- NG >> GO TO 4.

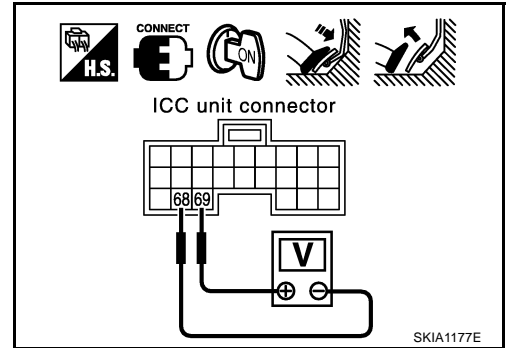

4. CHECK HARNESS BETWEEN ICC UNIT AND ECM

- Turn ignition switch OFF.
- Disconnect harness connectors of ICC unit and ECM.
- Check continuity between ICC unit harness connector B245 terminal 69 (R/Y) and ECM harness connector F102 terminal 113 (R/Y).

Continuity should exist.

- Check continuity between ICC unit harness connector B245 terminal 69 (R/Y) and ground.

Continuity should not exist.

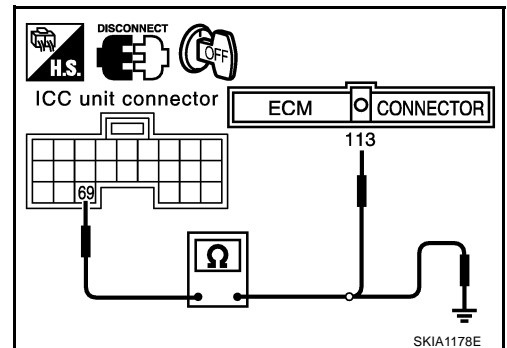

OK or NG

- OK >>
 - Check ECM.
 - After repair, erase DTC and perform ICC system running test. Then, perform self-diagnosis of ICC system again.
- NG >>
 - Repair harness between ICC unit and ECM
 - After repair, erase DTC, and perform ICC system running test. Then perform self-diagnosis of ICC system again.

5. DIAGNOSIS CHECK 1

With CONSULT-II

- Perform self-diagnosis. Is "CAN COMM CIRCUIT" indicated?

Yes or No

- Yes >> Repair or replace applicable item. Erase DTC and perform ICC system running test. Then perform self-diagnosis of ICC system again.
- No >> GO TO 6.

6. DIAGNOSIS CHECK 2**Ⓟ With CONSULT-II**

- Perform self-diagnosis of ECM with CONSULT-II. Is malfunction indicated?

Yes or No

- Yes >> Repair or replace applicable item. Erase DTC and perform ICC system running test. Then perform self-diagnosis of ICC system again.
- No >> Replace ICC unit. Erase DTC and perform ICC system running test. Then perform self-diagnosis of ICC system again.

DTC 43 ABS/TCS/VDC CIRC

EKS003PF

1. DIAGNOSIS CHECK 1**Ⓟ With CONSULT-II**

- Perform self-diagnosis. Is "CAN COMM CIRCUIT" indicated?

Yes or No

- Yes >> Repair or replace applicable item. Erase DTC and perform ICC system running test. Then perform self-diagnosis of ICC system again.
- No >> GO TO 2.

2. DIAGNOSIS CHECK 2**Ⓟ With CONSULT-II**

- Perform self-diagnosis of ABS/TCS/VDC control unit. Is malfunction indicated?

Yes or No

- Yes >> Repair or replace applicable item. Erase DTC and perform ICC system running test. Then perform self-diagnosis of ICC system again.
- No >> Replace ICC unit. Erase DTC and perform ICC system running test. Then perform self-diagnosis of ICC system again.

DTC 45 BRAKE SW/STOP L SW

EKS005QD

1. CHECK CONNECTOR FOR ICC UNIT

1. Turn ignition switch OFF.
2. Disconnect ICC unit connector, and connect it securely again. Then erase DTC. After that, perform self-diagnosis of ICC system again.

OK or NG

- OK >> ● Poor connector connection
- Check connector. (Check connector housing for disconnected, loose, bent, and collapsed terminals. If any malfunction is detected, repair applicable part.) After repair, erase DTC, and perform ICC system running test. Then perform self-diagnosis of ICC system again.
- NG >> GO TO 2.

2. CHECK STOP LAMP SWITCH AND ICC BRAKE SWITCH**Ⓟ With CONSULT-II**

- With data monitor, check if "STOP LAMP SW" and "BRAKE SW" are operated normally. Refer to [ACS-58](#), "DATA MONITOR".

OK or NG

- OK >> Replace ICC unit. Erase DTC and perform ICC system running test. Then perform self-diagnosis of ICC system again.
- NG >> ● BRAKE SW: GO TO 3.
- STOP LAMP SW: GO TO 5.

3. BRAKE SWITCH INSTALLATION AND ADJUSTMENT INSPECTION

- Check brake switch for proper installation and adjust if necessary. Refer to [BR-6, "BRAKE PEDAL"](#) in BR.
- OK or NG
- NG >> After adjustment, erase DTC and perform ICC system running test. Then perform self-diagnosis of ICC system again.
 - OK >> GO TO 4.

4. CHECK ICC BRAKE SWITCH

- Check ICC brake switch. Refer to [ACS-99, "ICC Brake Switch and Stop Lamp Switch"](#) .
- OK or NG
- OK >> Replace ICC unit. Erase DTC and perform ICC system running test. Then perform self-diagnosis of ICC system again.
 - NG >> Replace ICC brake switch. Erase DTC and perform ICC system running test. Then perform self-diagnosis of ICC system again.

5. CHECK STOP LAMP ILLUMINATION

- Check stop lamp illumination.
- OK or NG
- NG >> ● Check stop lamp circuit.
 - After repair, erase DTC and perform ICC system running test. Then, perform self-diagnosis of ICC system again.
 - OK >> GO TO 6.

6. CHECK ICC BRAKE HOLD RELAY

1. Turn ignition switch OFF.
2. Check continuity between ICC brake hold relay.

6 - 7 Continuity should not exist.
3 - 4 Continuity should exist.

OK or NG

- NG >> Replace brake hold relay. Erase DTC and perform ICC system running test. Then perform self-diagnosis of ICC system again.
- OK >> GO TO 7.

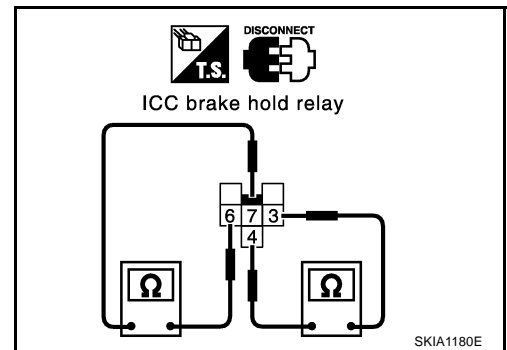

7. CHECK ICC BRAKE HOLD RELAY CIRCUIT

1. Disconnect connectors of ICC unit and ICC brake hold relay.
2. Check continuity between ICC unit harness connector B244 terminal 38 (R/W) and ICC brake hold relay harness connector E38 terminal 7 (R/W).

Continuity should exist.

3. Check continuity between ICC unit harness connector B244 terminal 38 (R/W) and stop lamp switch harness connector M402 terminal 2 (R/W).

Continuity should exist.

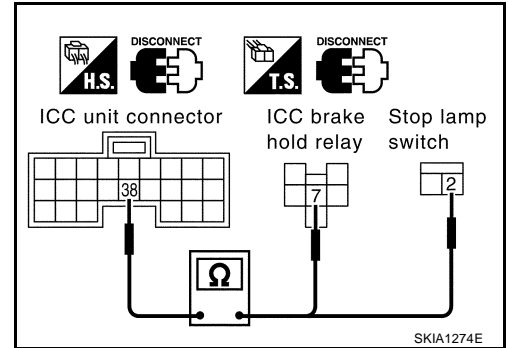

OK or NG

- NG >> ● Repair harness between ICC unit and ICC brake hold relay.
 - After repair, erase DTC and perform ICC system running test. Then, perform self-diagnosis of ICC system again.
- OK >> Replace ICC unit. Erase DTC and perform ICC system running test. Then perform self-diagnosis of ICC system again.

DTC 46 OPERATION SW CIRC

EKS005QE

1. CHECK CONNECTORS ICC UNIT, COMBINATION SWITCH AND ICC STEERING SWITCH

- Check ICC unit, combination switch and ICC steering switch terminals (ICC unit side, combination switch side, switch side, and harness side) for looseness and bend.

OK or NG

- NG >> Check connector. (Check connector housing for disconnected, loose, bent, and collapsed terminals. If any malfunction is detected, repair applicable part.) After repair, erase DTC, and perform ICC system running test. Then perform self-diagnosis of ICC system again.
- OK >> GO TO 2.

A
B
C
D
E
F
G
H
I
J
L
M

2. CHECK ICC STEERING SWITCH SIGNAL CIRCUIT

1. Turn ignition switch OFF.
2. Disconnect connectors of ICC unit and spiral cable.
3. Check continuity between ICC unit harness connector B245 terminal 49 (B/Y), 58 (GY/L) and spiral cable (on vehicle) M53 terminal 26 (G/OR), 31 (G).

49 - 26, 58 - 31 Continuity should exist.

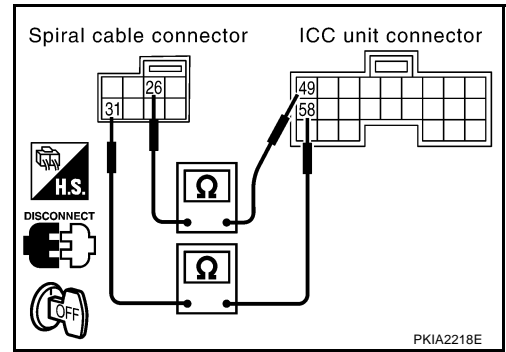

4. Check continuity between spiral cable (on vehicle) M53 terminal 26 (G/OR), 31 (G) and spiral cable (on switch) M441 terminal 18 (Y), 17 (G).

26 - 18, 31 - 17 Continuity should exist.

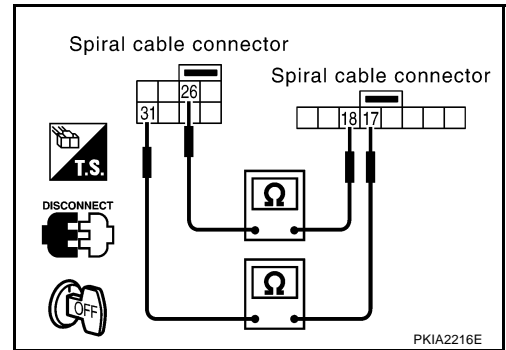

5. Check continuity between spiral cable M441 terminal 18 (Y), 17 (G) and ICC steering switch harness connector M443 terminal 1 (Y), 2 (G).

18 - 1, 17 - 2 Continuity should exist.

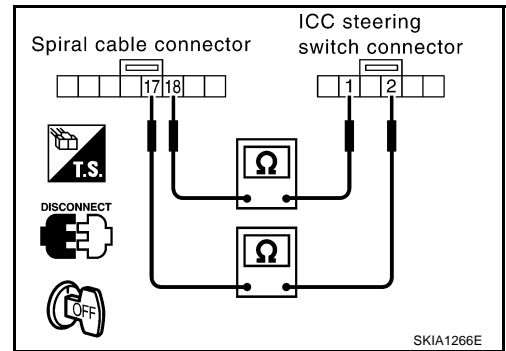

OK or NG

- NG >> ● Repair harness between ICC unit and spiral cable.
 ● After repair, erase DTC and perform ICC system running test. Then, perform self-diagnosis of ICC system again.
- OK >> GO TO 3.

3. CHECK ICC STEERING SWITCH

- Check ICC steering switch, refer to [ACS-99, "ICC Steering Switch"](#) .

OK or NG

- NG >> Replace ICC steering switch. Erase DTC and perform ICC system running test. Then perform self-diagnosis of ICC system again.
- OK >> Replace ICC unit. Erase DTC and perform ICC system running test. Then perform self-diagnosis of ICC system again.

DTC 61 PRESS SEN CIRCUIT

1. CHECK CONNECTOR BRAKE PRESSURE SENSOR AND ICC UNIT

1. Turn ignition switch OFF.
2. Disconnect connectors of brake pressure sensor and ICC unit, and connect them securely again. Then erase DTC. After that, perform self-diagnosis of ICC system again.

OK or NG

- OK >> ● Poor connector connection
- Check connector. (Check connector housing for disconnected, loose, bent, and collapsed terminals. If any malfunction is detected, repair applicable part.) After repair, Erase DTC, and perform ICC system running test. Then perform self-diagnosis of ICC system again.

NG >> GO TO 2.

2. CHECK HARNESS BETWEEN BRAKE PRESSURE SENSOR AND ICC UNIT

1. Turn ignition switch OFF.
2. Disconnect connectors of ICC unit and brake pressure sensor.
3. Check continuity between ICC unit harness connector B243 terminal 8 (P/U), 17 (B/Y), 24 (OR) and brake pressure sensor harness connector E82 terminal 3 (P/U), 2 (B/Y), 1 (OR).

8 - 3, 17 - 2, 24 - 1 Continuity should exist.

OK or NG

- NG >> ● Repair harness between brake pressure sensor and ICC unit
- After repair, erase DTC and perform ICC system running test. Then, perform self-diagnosis of ICC system again.

OK >> GO TO 3.

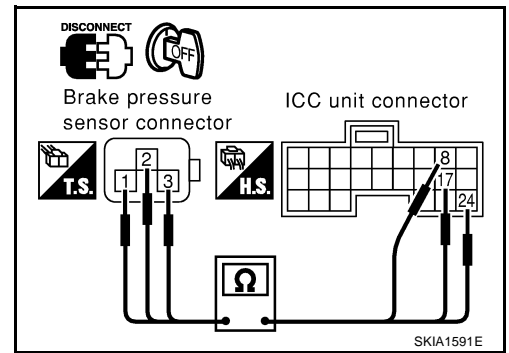

3. CHECK POWER SUPPLY CIRCUIT FOR BRAKE PRESSURE SENSOR

1. Connect ICC unit.
2. Turn ignition switch ON.
3. Check voltage between ICC unit harness connector B243 terminal 8 (P/U) and 24 (OR).

8 (+) - 24 (-) Approx. 5V

OK or NG

- NG >> Replace ICC unit. Clear DTC and perform driving check. Then perform self-diagnosis of ICC system again.
- OK >> ● Brake pressure sensor malfunction
- Replace master cylinder assembly. Erase DTC and perform ICC system running test. Then perform self-diagnosis of ICC system again.

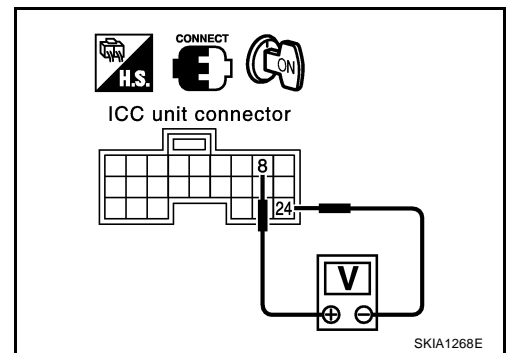

DTC 62 BOOSTER SOL/V CIRCUIT

1. CHECK SOLENOID/RELEASE SWITCH AND ICC UNIT CHECK CONNECTOR

1. Turn ignition switch OFF.
2. Disconnect connectors of brake booster solenoid/release and ICC unit, and connect them securely again. Then erase DTC. After that perform self-diagnosis of ICC system again.

OK or NG

- OK >> ● Poor connector connection
- Check connector. (Check connector housing for disconnected, loose, bent, and collapsed terminals. If any malfunction is detected, repair applicable part.) After repair, erase DTC, and perform ICC system running test. Then perform self-diagnosis of ICC system again.

NG >> GO TO 2.

A
B
C
D
E
F
G
H
I
J
L
M

ACS

2. CHECK HARNESS BETWEEN SOLENOID/RELEASE SWITCH AND ICC UNIT

1. Turn ignition switch OFF.
2. Disconnect ICC unit connector and brake booster solenoid release switch connector.
3. Check continuity between ICC unit harness connector B243 terminal 10 (W/R), 12 (B/R) and brake booster harness connector E81 terminal 4 (W/R), 6 (B/R).

10 - 4, 12 - 6

Continuity should exist.

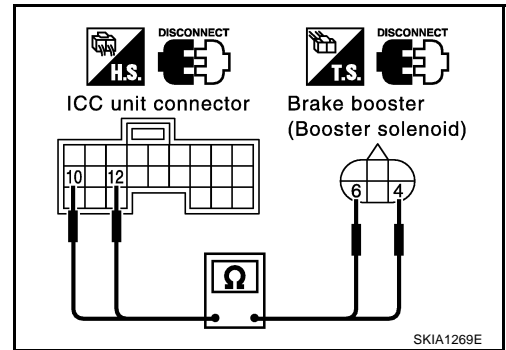

OK or NG

- NG >> ● Repair harness between brake booster solenoid/ release switch and ICC unit
- After repair, Erase DTC and perform ICC system running test. Then, perform self-diagnosis of ICC system again.
- OK >> GO TO 3.

3. CHECK BOOSTER SOLENOID

- Check booster solenoid. Refer to [ACS-99, "Booster Solenoid"](#) .

OK or NG

- NG >> ● Replace Booster solenoid
- Replace booster solenoid. Erase DTC and perform ICC system running test. Then perform self-diagnosis of ICC system again.
- OK >> Replace ICC unit. Erase DTC and perform ICC system running test. Then perform self-diagnosis of ICC system again.

DTC 63 RELEASE SW CIRCUIT

EKS003PK

1. CHECK SOLENOID/RELEASE SWITCH AND ICC UNIT CHECK CONNECTOR

1. Turn ignition switch OFF.
2. Disconnect brake booster solenoid/release switch connector and ICC unit connector, and connect them securely again. Then erase DTC. After that, perform self-diagnosis of ICC system again.

OK or NG

- OK >> ● Poor connector connection
- Check connector. (Check connector housing for disconnected, loose, bent, and collapsed terminals. If any malfunction is detected, repair applicable part.) After repair, erase DTC, and perform ICC system running test. Then perform self-diagnosis of ICC system again.
- NG >> GO TO 2.

2. CHECK HARNESS SOLENOID/RELEASE SWITCH AND ICC UNIT

1. Turn ignition switch OFF.
2. Disconnect brake booster solenoid/release switch connector and ICC unit connector.
3. Check continuity between ICC unit harness connector B243 terminal 6 (L), 15 (P), 22 (R/B) and Brake booster harness connector E81 terminal 1 (L), 3 (P), 2 (R/B).

6 - 1, 15 - 3, 22 - 2 Continuity should exist.

OK or NG

- NG >> ● Repair harness between brake booster solenoid/release switch and ICC unit
- After repair, Erase DTC and perform ICC system running test. Then, perform self-diagnosis of ICC system again.
- OK >> GO TO 3.

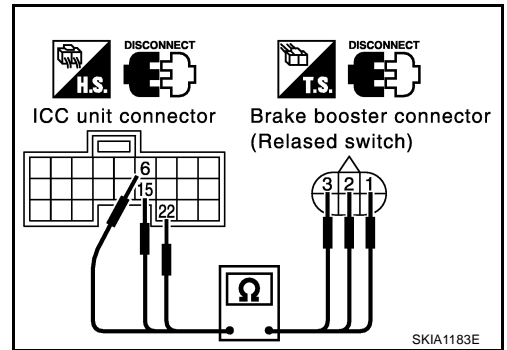

3. CHECK RELEASE SWITCH POWER SUPPLY CIRCUIT

- Check voltage between ICC unit harness connector B243 terminal 6 (L) and ground.

Approx. 10V

OK or NG

- NG >> Replace ICC unit. Erase DTC and perform ICC system running test. Then perform self-diagnosis of ICC system again.
- OK >> GO TO 4.

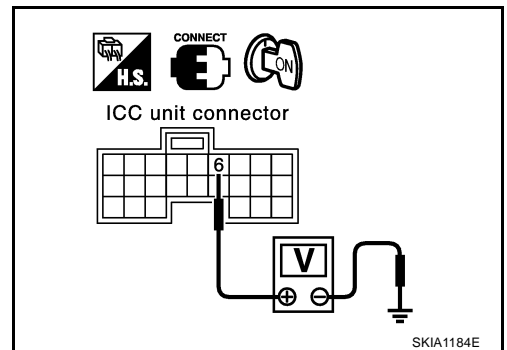

4. CHECK RELEASE SWITCH

- Check release switch. Refer to [ACS-100, "Release Switch"](#).

OK or NG

- NG >> ● Release switch malfunction
- Replace booster. Erase DTC and perform ICC system running test. Then perform self-diagnosis of ICC system again.
- OK >> Replace ICC unit. Erase DTC and perform ICC system running test. Then perform self-diagnosis of ICC system again.

DTC 65 PRESSURE CONTROL

EKS003PL

1. OPERATION CHECK

- Check foot brake pedal operates normally.

OK or NG

- NG >> ● Check brake circuit.
- After repair, Erase DTC, and perform active test (BOOSTER SOL/V3) with CONSULT-II. Then perform self-diagnosis of ICC system again.
- OK >> GO TO 2.

A
B
C
D
E
F
G
H
I
J
L
M

ACS

2. CHECK BOOSTER SOLENOID

- Check booster solenoid. Refer to [ACS-99, "Booster Solenoid"](#) .

OK or NG

NG >> ● Solenoid malfunction

- Replace booster. Erase DTC and perform ICC system running test. Then perform self-diagnosis of ICC system again.

OK >> GO TO 3.

3. CHECK HARNESS BETWEEN SOLENOID/RELEASE SWITCH AND ICC UNIT

1. Turn ignition switch OFF.
2. Disconnect ICC unit connector and brake booster solenoid/release switch connector.
3. Check continuity between ICC unit harness connector B243 terminal 10 (W/R), 12 (B/R) and brake booster solenoid/release harness connector E81 terminal 4 (W/R), 6 (B/R).

10 - 4, 12 - 6

Continuity should exist.

OK or NG

NG >> ● Repair harness between brake booster solenoid/release switch and ICC unit

- After repair, Erase DTC and perform ICC system running test. Then, perform self-diagnosis of ICC system again.

OK >> Replace ICC unit. Erase DTC and perform ICC system running test. Then perform self-diagnosis of ICC system again.

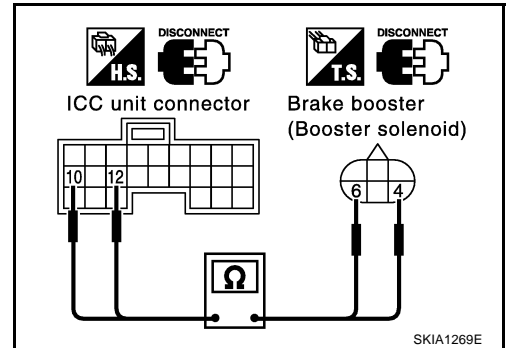

DTC 74 LASER BEAM OFF CNTR

EKS003PM

1. DIAGNOSTIC CHECK

1. Adjust laser beam aiming. Then erase DTC, and perform ICC system running test.
2. After that, perform self-diagnosis of ICC system. Is DTC 74 LASER BEAM OFF CNTR indicated?

Yes or No

Yes >> ● Replace ICC sensor, and adjust laser beam aiming.

- After that, Erase DTC and perform ICC system running test. Then perform self-diagnosis of ICC system again.

No >> Inspection is completed.

DTC 81 POWER SUPPLY VALVE

EKS003PN

1. CHECK ICC UNIT REFERENCE SIGNAL

1. Start the engine.
2. Turn ON/OFF switch ON.
3. Check voltage between ICC unit harness connector B245 terminal 57 (R) and ground.

Approx. 0V

OK or NG

NG >> GO TO 2.

OK >> GO TO 3.

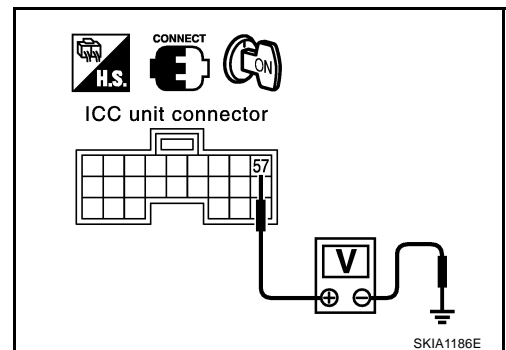

2. CHECK HARNESS BETWEEN ICC UNIT AND ASCD PUMP

1. Turn ignition switch OFF.
2. Disconnect ASCD pump connector.
3. Check voltage between ASCD pump harness connector E15 terminal 1 (R) and ground.

Approx. 0V

OK or NG

- NG >> ● Repair harness between ICC unit and ASCD pump
 ● After repair, erase DTC and perform ICC system running test. Then, perform self-diagnosis of ICC system again.
- OK >> Replace ICC unit. Erase DTC and perform ICC system running test. Then perform self-diagnosis of ICC system again.

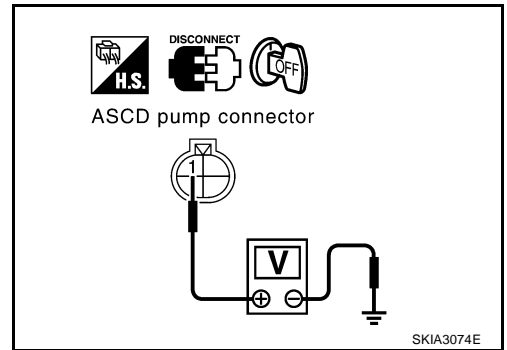

3. CHECK ICC UNIT REFERENCE SIGNAL

1. Start engine.
2. Turn ON/OFF switch ON.
3. Check voltage between ICC unit harness connector B245 terminal 70 (Y/B) and ground.

Approx. 0V

OK or NG

- NG >> ● Repair harness between ICC unit and ASCD actuator
 ● After repair, erase DTC and perform ICC system running test. Then, perform self-diagnosis of ICC system again.
- OK >> Replace ICC unit. Erase DTC and perform ICC system running test. Then perform self-diagnosis of ICC system again.

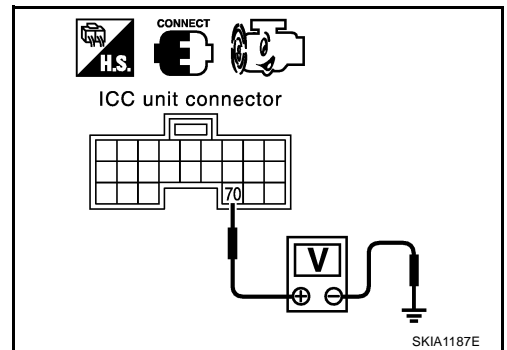

DTC 83 POWER SUPPLY VALVE

EKS003PO

1. CHECK ASCD ACTUATOR

- Check ASCD actuator. Refer to [ACS-100, "ASCD Actuator"](#).

OK or NG

- NG >> Replace ASCD actuator. Erase DTC, and perform self-diagnosis of ICC system again.
- OK >> GO TO 2.

2. CHECK HARNESS BETWEEN ICC UNIT AND ASCD PUMP

1. Turn ignition switch OFF.
2. Check continuity between ICC unit harness connector B245 terminal 57 (R), 72 (L/R) and ASCD pump harness connector E15 terminal 1 (R), 4 (L/R).

57 - 1, 72 - 4

Continuity should exist.

OK or NG

- NG >> ● Repair harness between ICC unit and ASCD pump
 ● After repair, erase DTC and perform ICC system running test. Then, perform self-diagnosis of ICC system again.
- OK >> GO TO 3.

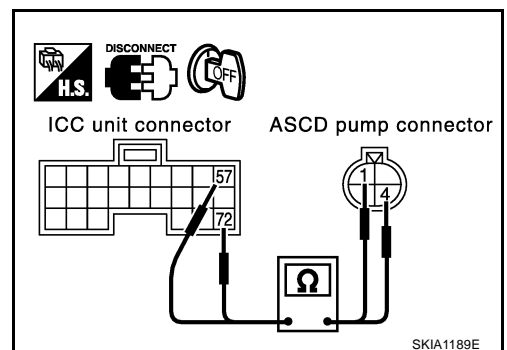

A
B
C
D
E
F
G
H
I
J
L
M

ACS

3. CHECK CONNECTOR ASCD PUMP AND ICC UNIT

- Check ASCD pump and ICC unit terminal for looseness and bend.

OK or NG

- NG >> Repair terminal or connector. Erase DTC, and perform self-diagnosis of ICC system again.
- OK >> Replace ICC unit. Erase DTC, and perform self-diagnosis of ICC system again.

DTC 85 AIR VALVE [LOW VOLTAGE]

EKS003PP

1. CHECK ASCD PUMP

- Check ASCD pump. Refer to [ACS-100, "ASCD Pump"](#).

OK or NG

- NG >> Replace ASCD pump. Erase DTC, and perform self-diagnosis of ICC system again.
- OK >> GO TO 2.

2. CHECK HARNESS BETWEEN ICC UNIT AND ASCD PUMP

1. Turn ignition switch OFF.
2. Check continuity between ICC unit harness connector B245 terminal 57 (R), 71 (G/Y) and ASCD pump harness connector E15 terminal 1 (R), 2 (G/Y).

57 - 1, 71 - 2 Continuity should exist.

OK or NG

- NG >> ● Repair harness between ICC unit and ASCD pump
 - After repair, erase DTC, and perform self-diagnosis of ICC system again.
- OK >> GO TO 3.

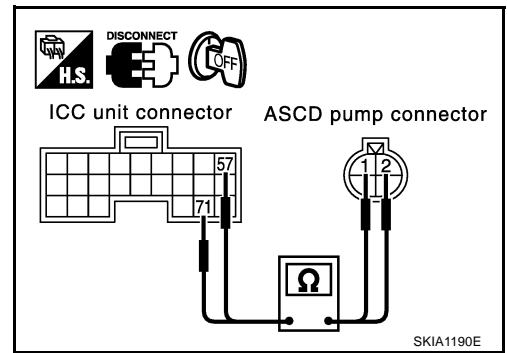

3. CHECK CONNECTOR PUMP ASCD AND ICC UNIT

- Check ASCD pump and ICC unit terminal for looseness and bend.

OK or NG

- NG >> Repair terminal or connector. Erase DTC, and perform self-diagnosis of ICC system again.
- OK >> Replace ICC unit. Erase DTC, and perform self-diagnosis of ICC system again.

DTC 87 RELEASE VALVE [LOW VOLTAGE]

EKS003PQ

1. CHECK ASCD PUMP

- Check ASCD pump. Refer to [ACS-100, "ASCD Pump"](#)

OK or NG

- NG >> Replace ASCD pump. Erase DTC, and perform self-diagnosis of ICC system again.
- OK >> GO TO 2.

2. CHECK HARNESS BETWEEN ICC UNIT AND PUMP

1. Turn ignition switch OFF.
2. Check continuity between ICC unit harness connector B245 terminal 57 (R), 70 (Y/B) and ASCD pump harness connector E15 terminal 1 (R), 3 (Y/B).

57 - 1, 70 - 3 Continuity should exist.

OK or NG

- NG >> ● Repair harness between ICC unit and ASCD pump
 - After repair, erase DTC, and perform self-diagnosis of ICC system again.
- OK >> GO TO 3.

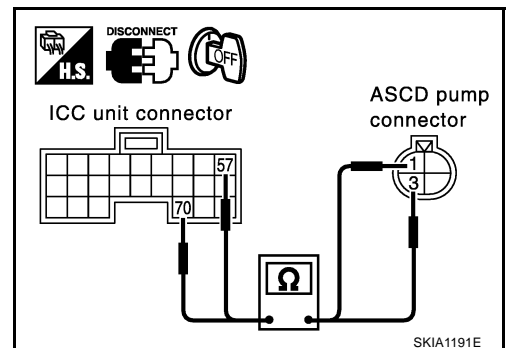

3. CHECK CONNECTOR ASCD PUMP AND ICC UNIT

- Check ASCD pump and ICC unit terminal for looseness or bend.

OK or NG

- NG >> Repair terminal or connector. Erase DTC, and perform self-diagnosis of ICC system again.
- OK >> Replace ICC unit. Erase DTC, and perform self-diagnosis of ICC system again.

DTC 90 STOP LAMP RLY FIX

EKS003PR

1. CHECK CONNECTOR ICC UNIT

1. Turn ignition switch OFF.
2. Disconnect and check ICC unit connector.

OK or NG

- NG >> ● Connector malfunction
 - After repair, erase DTC, and perform ICC system running test. Then perform self-diagnosis of system.
- OK >> GO TO 2.

2. CHECK STOP LAMP SWITCH, AND ICC BRAKE SWITCH

 **With CONSULT-II**

- With data monitor, check that "STOP LAMP SW" and "BRAKE SW" operate normally. Refer to [ACS-58, "DATA MONITOR"](#).

OK or NG

- NG >> ● BRAKE SW: GO TO 3.
 - STOP LAMP SW: GO TO 8.
- OK >> GO TO 11.

3. BRAKE SWITCH INSTALLATION AND ADJUSTMENT INSPECTION

- Check brake switch for proper installation and adjust if necessary. Refer to [BR-6, "BRAKE PEDAL"](#) in "BR".

OK or NG

- NG >> After adjustment, erase DTC and perform ICC system running test. Then perform self-diagnosis of ICC system again.
- OK >> GO TO 4.

4. CHECK ICC BRAKE SWITCH AND STOP LAMP SWITCH

- Check ICC brake switch and stop lamp switch. Refer to [ACS-99, "ICC Brake Switch and Stop Lamp Switch"](#).

OK or NG

- NG >> Replace ICC brake switch. Erase DTC and perform ICC system running test. Then perform self-diagnosis of ICC system again.
- OK >> GO TO 5.

A
B
C
D
E
F
G
H
I
J
L
M

ACS

5. CHECK ICC BRAKE HOLD RELAY

- Disconnect ICC brake hold relay E38, and check continuity between ICC brake hold relay harness connector terminal 3 and terminal 4.

Continuity should exist.

OK or NG

- NG >> Replace ICC brake hold relay. Erase DTC and perform ICC system running test. Then perform self-diagnosis of ICC system again.
- OK >> GO TO 6.

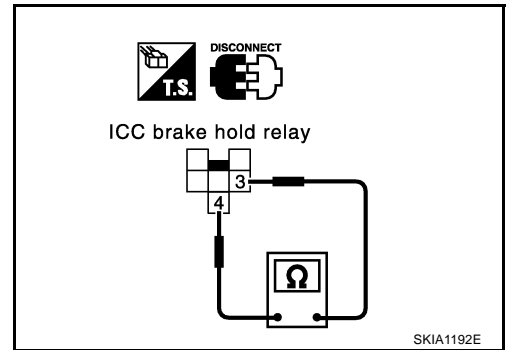

6. CHECK HARNESS THROUGH ICC BRAKE HOLD RELAY, ICC BRAKE SWITCH, ICC UNIT

1. Disconnect ICC brake hold relay E38, ICC brake switch M404, ICC unit harness connector B244.
2. Check continuity between ICC brake hold relay harness connector E38 terminal 3 (Y/R) and ICC brake switch harness connector M404 terminal 1 (BR/Y).

Continuity should exist.

3. Check continuity between ICC brake hold relay harness connector E38 terminal 3 (Y/R) and ground.

Continuity should not exist.

4. Check continuity between ICC brake hold relay harness connector E38 terminal 1 (L/W) and ICC unit harness connector B244 terminal 47 (L/W).

Continuity should exist.

5. Check continuity between ICC unit harness connector B244 terminal 47 (L/W) and ground.

Continuity should not exist.

OK or NG

- NG >> ● Repair harness between ICC brake hold relay and ICC brake switch.
- Repair harness between ICC brake switch and ICC unit.
- After repair, erase DTC and perform ICC system running test. Then, perform self-diagnosis of ICC system again.
- OK >> GO TO 7.

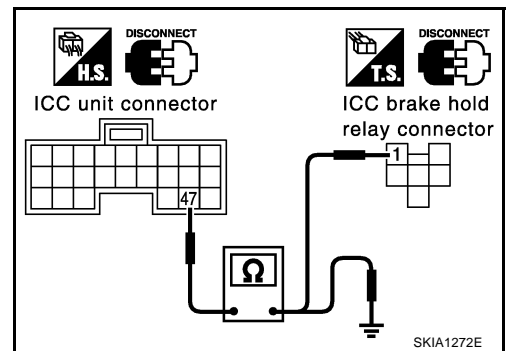
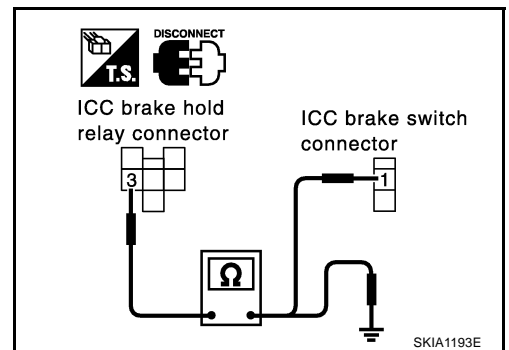

7. CHECK ICC BRAKE HOLD RELAY POWER SUPPLY CIRCUIT

1. Turn ignition switch ON.
2. Check voltage between ICC brake hold relay harness connector E38 terminal 4 (R/B) and ground.

Approx. 12V

OK or NG

- NG >> ● Malfunction of fuse, or ICC brake hold relay power supply system harness.
- After repair, erase DTC and perform ICC system running test. Then, perform self-diagnosis of ICC system again.

- OK >> Replace ICC unit. Erase DTC and perform ICC system running test. Then perform self-diagnosis of ICC system again.

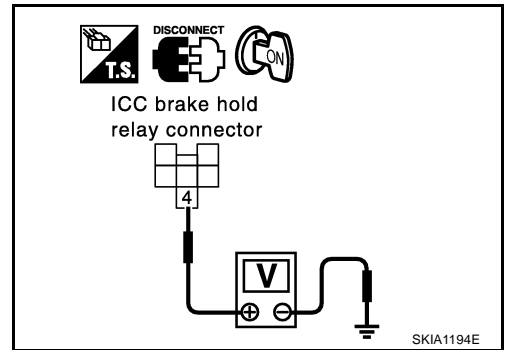

8. CHECK BRAKE LAMP ILLUMINATION

1. Disconnect ICC brake hold relay connector.
2. Check stop lamp circuit.

OK or NG

- NG >> After repair, erase DTC and perform ICC system running test. Then, perform self-diagnosis of ICC system again.

- OK >> GO TO 9.

9. CHECK ICC BRAKE HOLD RELAY CIRCUIT

1. Connect ICC brake hold relay connector.
2. Disconnect stop lamp switch connector.
3. When brake pedal is not depressed, make sure that stop lamp does not illuminate.

OK or NG

- NG >> GO TO 10.

- OK >> Replace ICC unit. Erase DTC and perform ICC system running test. Then perform self-diagnosis of ICC system again.

10. CHECK ICC BRAKE HOLD RELAY

1. Disconnect ICC brake hold relay.
2. Check continuity between ICC brake hold relay E38 terminal 6 and terminal 7.

Continuity should not exist.

OK or NG

- NG >> Replace ICC brake hold relay. Erase DTC and perform ICC system running test. Then perform self-diagnosis of ICC system again.

- OK >> Replace ICC unit. Erase DTC and perform ICC system running test. Then perform self-diagnosis of ICC system again.

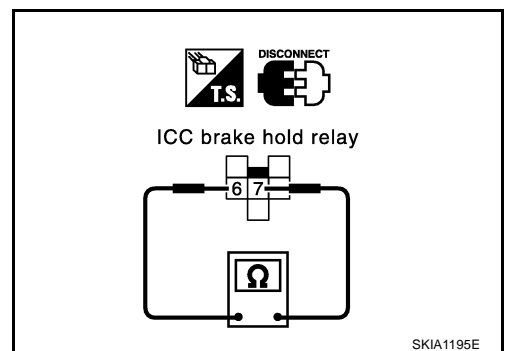

A
B
C
D
E
F
G
H
I
J
L
M

ACS

14. CHECK ICC BRAKE HOLD RELAY POWER SUPPLY CIRCUIT

1. Check voltage between ICC brake hold relay E38 terminal 6 (R/Y) and ground.

6 - Ground

Approx. 12V

OK or NG

- NG >> ● Malfunctions of fuse or ICC brake hold relay power supply harness.
- After repair, erase DTC and perform ICC system running test. Then, perform self-diagnosis of ICC system again.
- OK >> GO TO 15.

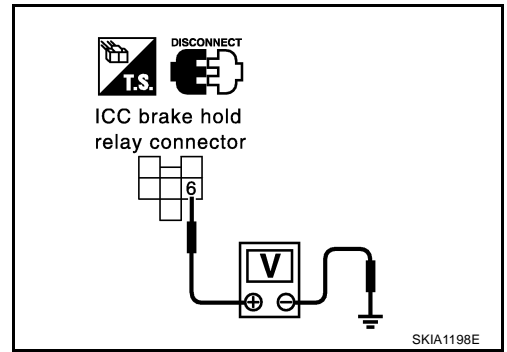

15. CHECK HARNESS BETWEEN ICC BRAKE HOLD RELAY AND ICC UNIT

1. Disconnect connectors of ICC brake hold relay and ICC unit.
2. Check continuity between ICC brake hold relay harness connector E38 terminal 7 (R/W) and ICC unit harness connector B244 terminal 38 (R/W).
3. Check continuity between ICC unit harness connector B244 terminal 38 (R/W) and ground.

7 - 38

Continuity should exist.

38 - Ground

Continuity should not exist.

OK or NG

- NG >> ● Repair harness between ICC brake hold relay and ICC unit.
- After repair, erase DTC and perform ICC system running test. Then, perform self-diagnosis of ICC system again.
- OK >> GO TO 16.

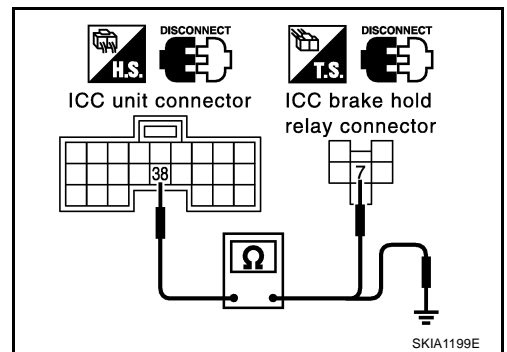

16. CHECK ICC BRAKE HOLD RELAY

Ⓟ **With CONSULT-II**

1. Connect connectors of ICC unit and ICC brake hold relay.
2. Disconnect stop lamp switch connector.
3. Perform active test (STOP LAMP) with CONSULT-II, and make sure that stop lamp is illuminated.

OK or NG

- NG >> Replace ICC brake hold relay. Erase DTC and perform ICC system running test. Then perform self-diagnosis of ICC system again.
- OK >> GO TO 17.

A
B
C
D
E
F
G
H
I
J
L
M

ACS

17. CHECK ICC UNIT STANDARD VOLTAGE

1. Connect stop lamp switch connector.
2. Perform active test (STOP LAMP:STP LMP DRIVE ON) with CONSULT-II, check voltage between ICC unit harness connector B244 terminal 29 (G) and ground.

29 - Ground **Approx. 0V (during active test)**

OK or NG

- NG >> Replace stop lamp switch. Erase DTC and perform ICC system running test. Then perform self-diagnosis of ICC system again.
- OK >> Replace ICC unit. Erase DTC and perform ICC system running test. Then perform self-diagnosis of ICC system again.

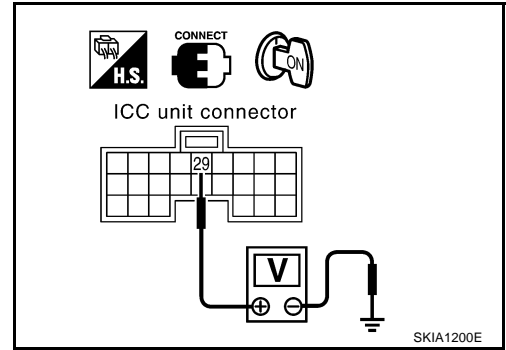

DTC 92 ECM CIRCUIT

EKS003PS

1. DIAGNOSIS CHECK 1

With CONSULT-II

- Perform self-diagnosis with CONSULT-II. Is “CAN COMM CIRCUIT” indicated?

Yes or No

- Yes >> Repair or replace applicable item. Erase DTC and perform ICC system running test. Then perform self-diagnosis of ICC system again.
- No >> GO TO 2.

2. DIAGNOSIS CHECK 2

With CONSULT-II

- Perform ECM self-diagnosis with CONSULT-II. Is malfunction indicated?

Yes or No

- Yes >> Repair or replace applicable item. Erase DTC and perform ICC system running test. Then perform self-diagnosis of ICC system again.
- No >> Replace ICC unit. Erase DTC and perform ICC system running test. Then perform self-diagnosis of ICC system again.

DTC 97 AT CIRCUIT

EKS003PT

1. CHECK AT CIRCUIT

With CONSULT-II

- With TCM data monitor with CONSULT-II, check shift operates normally.

OK or NG

- NG >> ● Perform TCM diagnosis.
 ● After repair, Erase DTC, and perform self-diagnosis of ICC system again.
- OK >> Replace ICC unit. Erase DTC, and perform self-diagnosis of ICC system again.

DTC 98 GEAR POSITION

EKS003PU

1. DIAGNOSTIC CHECK

With CONSULT-II

- Is “DTC 43 ABS/TCS/VDC CIRC” or “DTC 41 VHCL SPEED SE CIRC” indicated in self-diagnosis display item?

Yes or No

- Yes >> Repair or replace applicable item. Erase DTC, and perform self-diagnosis of ICC system again.
- No >> GO TO 2.

2. CHECK VEHICLE SPEED SIGNAL

④ With CONSULT-II

- With data monitor with CONSULT-II, check vehicle speed signal operates normally.

OK or NG

- NG >> Replace ICC unit. Erase DTC, and perform self-diagnosis of ICC system again.
OK >> GO TO 3.

3. CHECK SHIFT GEAR POSITION

- Check that gear positions are correct in A/T.

OK or NG

- NG >> GO TO 4.
OK >> GO TO 5.

4. CHECK TCM GEAR POSITION SIGNAL

④ With CONSULT-II

- With TCM data monitor with CONSULT-II, check that gear positions are correct.

OK or NG

- NG >> ● Perform TCM diagnosis.
● After repair, Erase DTC, and perform self-diagnosis of ICC system again.
OK >> Replace ICC unit. Erase DTC, and perform self-diagnosis of ICC system again.

5. CHECK TCM TURBINE ROTATION

④ With CONSULT-II

- With TCM data monitor with CONSULT-II, check that turbine rpm is normal.

OK or NG

- NG >> ● Perform TCM diagnosis.
● After repair, Erase DTC, and perform self-diagnosis of ICC system again.
OK >> Replace ICC unit. Erase DTC, and perform self-diagnosis of ICC system again.

DTC 102 RADAR STAIN

EKS003PV

1. VISUAL INSPECTION (1)

- Check that there is no contamination and foreign material on ICC sensor body window.

Yes or No

- Yes >> ● If any, remove them.
● After that, Erase DTC, Erase DTC and perform ICC system running test. Then perform self-diagnosis of ICC system again.
No >> GO TO 2.

2. VISUAL INSPECTION (2)

- Check ICC sensor body window for cracks.

Yes or No

- Yes >> ● Replace ICC sensor, and adjust laser beam.
● After that, Erase DTC, Erase DTC and perform ICC system running test. Then perform self-diagnosis of ICC system again.
No >> GO TO 3.

3. ASKING COMPLAINTS

1. Is there any trace of contamination or foreign material on ICC sensor?
2. Is there any possibility that vehicle was driven in snow or ICC sensor was frosted?
3. Is there any possibility that ICC sensor was fogged temporarily? (Front window glass may have also tended to be fogged.)

Yes or No

- Yes >> Explain difference in displays between contamination detection result and current indication to customer, and tell them "This is not malfunction".
- No >> ● Replace ICC sensor, and adjust laser beam aiming.
- After that, Erase DTC and perform ICC system running test. Then perform self-diagnosis of ICC system again.

DTC 103 LASER SENSOR FAIL

EKS003PW

1. DIAGNOSTIC CHECK

- Are "DTC 11 CONTROL UNIT" or "DTC 20 CAN COMM CIRCUIT" item indicated in self-diagnosis display item?

Yes or No

- Yes >> GO TO APPLICABLE ITEM INSPECTION. Refer to [ACS-68, "DTC 11 CONTROL UNIT"](#) , and [ACS-68, "DTC 20 CAN COMM CIRCUIT"](#) .
- No >> ● Replace ICC sensor, and adjust laser beam aiming.
- After that, Erase DTC and perform ICC system running test. Then perform self-diagnosis of ICC system again.

DTC 104 LASER AIMING INCOMP

EKS003PX

1. DIAGNOSTIC CHECK

1. Adjust laser beam aiming. Erase DTC, and perform.
2. After that, perform self-diagnosis of ICC system. Is "DTC 104 LASER AIMING INCOMP" indicated?

Yes or No

- Yes >> ● Replace ICC sensor, and adjust laser beam aiming.
- After that, Erase DTC and perform ICC system running test. Then perform self-diagnosis of ICC system again.
- No >> Inspection is completed.

DTC 107 LASER COMM FAIL

EKS003PY

1. DIAGNOSTIC CHECK

- Is "DTC 11 CONTROL UNIT" or "DTC 20 CAN COMM CIRCUIT" items other than "DTC 107 LASER COMM FAIL" indicated in the self-diagnosis display item?

Yes or No

- Yes >> GO TO APPLICABLE ITEM INSPECTION. Refer to [ACS-68, "DTC 11 CONTROL UNIT"](#) , and [ACS-68, "DTC 20 CAN COMM CIRCUIT"](#) .
- No >> ● Replace ICC sensor. Adjust laser beam aiming.
- After that, Erase DTC and perform ICC system running test. Then perform self-diagnosis of ICC system again.

DTC 109 LASER HIGH TEMP

EKS003PZ

1. CHECK SYMPTOM

- Is cooling system malfunctioning?

Yes or No

Yes >> ● Repair cooling system.

- After that, Erase DTC and perform ICC system running test. Then perform self-diagnosis of ICC system again.

No >> ● Replace ICC sensor, and adjust laser beam aiming.

- After repair, Erase DTC. Then perform ICC system running test, and perform self-diagnosis of ICC unit.

A

B

C

D

E

F

G

H

I

J

ACS

L

M

TROUBLE DIAGNOSIS FOR SYMPTOMS

[ICC]

TROUBLE DIAGNOSIS FOR SYMPTOMS

PFP:00007

Symptom Chart

EKS003Q0

	Symptoms	Reference page
Operation	Cruise ON/OFF does not switch ON.	Symptom 1 ACS-91
	Cruise ON/OFF does not switch OFF.	Symptom 1 ACS-91
	Cruise does not function for setting (powering functions).	Symptom 2 ACS-93
	CANCEL switch does not function.	Symptom 3 ACS-94
	Resume does not function.	Symptom 3 ACS-94
	The set speed does not increase.	Symptom 3 ACS-94
	The set distance to the vehicle ahead cannot be changed.	Symptom 3 ACS-94
	The ICC is not cancelled when the gear is in other than D.	Symptom 4 ACS-95
Display/Chime	The ICC system display does not appear.	Check combination meter. Refer to DI-21, "ICC System Display Does Not Illuminate"
	Chime does not function.	Symptom 5 ACS-95
	Chime does not stop.	Symptom 6 ACS-97
Control	Driving force is hunting.	Symptom 7 ACS-97
Function to detect the vehicle ahead	The system frequently cannot detect the vehicle ahead.	Symptom 8 ACS-97
	The distance to detect the vehicle ahead is short.	Symptom 8 ACS-97
	The system misidentifies a vehicle even though there is no vehicle ahead.	<ul style="list-style-type: none"> Refer to ACS-38, "LASER BEAM AIMING ADJUSTMENT" Refer to ACS-36, "ICC System Running Test"
	The system misidentifies a vehicle in the next lane.	<ul style="list-style-type: none"> Refer to ACS-38, "LASER BEAM AIMING ADJUSTMENT" Refer to ACS-36, "ICC System Running Test"
	The system does not detect a vehicle at all.	Symptom 9 ACS-98

Symptom 1: Cruise ON/OFF Does Not Switch ON. (The ICC System Display in the Combination Meter Does Not Illuminate.) Cruise ON/OFF Does Not Switch OFF. (The ICC System Display in the Combination Meter Remains Powered.)

EKS005QG

1. CHECK ON/OFF SWITCH

- With data monitor, check that ON/OFF switch operates normally.

OK or NG

- OK >> GO TO 2.
- NG >> GO TO 4.

2. CHECK COMBINATION METER

- Check combination meter.

OK or NG

- OK >> GO TO 5.
- NG >> After repair or replacement, erase DTC, and perform self-diagnosis of ICC system again.

3. CHECK CAN COMMUNICATION

- Check that CAN communication operates normally.

OK or NG

- OK >> Replace ICC unit. Erase DTC, and perform self-diagnosis of ICC system again.
- NG >> Repair or replace malfunctioning part. Erase DTC, and perform self-diagnosis of ICC system again.

4. CHECK ICC UNIT REFERENCE SIGNAL

- Check voltage between ICC unit harness connector B245 terminal 49 (B/Y) and terminal 58 (GY/L). Refer to [ACS-53, "Terminals and Reference Value for ICC Unit"](#).

OK or NG

- OK >> GO TO 9.
- NG >> GO TO 5.

5. CHECK ICC STEERING SWITCH

Refer to [ACS-99, "ICC Steering Switch"](#).

OK or NG

- NG >> Replace ICC steering switch. Erase DTC, and perform self-diagnosis of ICC system again.
- OK >> GO TO 6.

A
B
C
D
E
F
G
H
I
J
L
M

ACS

6. CHECK ICC STEERING SWITCH HARNESS

1. Turn ignition switch OFF.
2. Disconnect ICC steering switch harness connector.
3. Check continuity between spiral cable M441 terminal 17 (G), 18 (Y) and ICC steering switch harness connector M443 terminal 1 (Y), 2 (G).

17 - 2, 18 - 1 Continuity should exist.

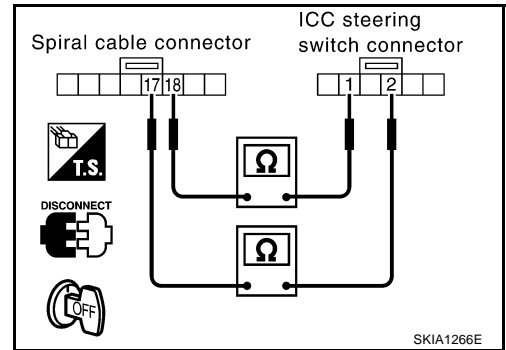

4. Check continuity between ICC steering switch harness connector M443 terminal 1 (Y), 2 (G) and ground.

1, 2 - Ground Continuity should not exist.

OK or NG

- NG >> Replace switch harness. Erase DTC, and perform self-diagnosis of ICC system again.
- OK >> GO TO 7.

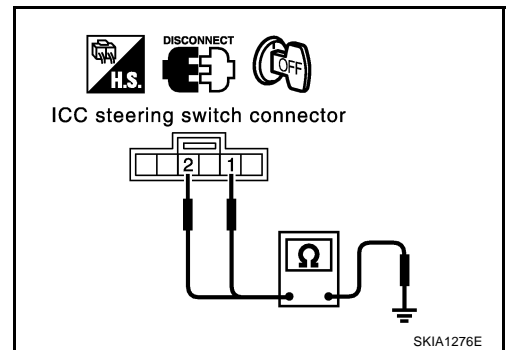

7. CHECK SPIRAL CABLE

1. Turn ignition switch OFF.
2. Disconnect spiral cable connector.
3. Check continuity between spiral cable (on vehicle) M53 terminal 31 (G), 26 (G/OR) and spiral cable (on switch) M441 terminal 18 (Y), 17 (G) .

31 - 17, 26 - 18 Continuity should exist.

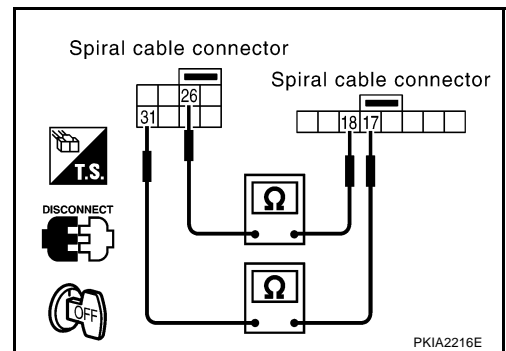

4. Check continuity between spiral cable (on vehicle) M53 terminal 31 (G), 26 (G/OR) and ground.

31, 26 - Ground Continuity should not exist.

OK or NG

- NG >> Replace spiral cable. Erase DTC, and perform self-diagnosis of ICC system again.
- OK >> GO TO 8.

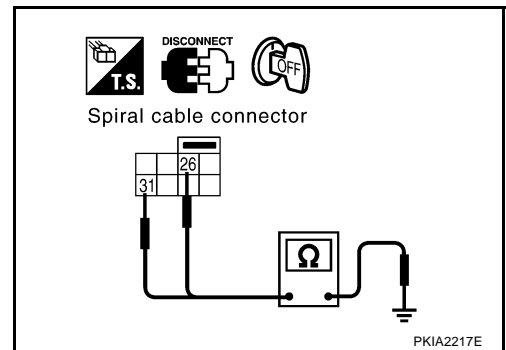

8. CHECK HARNESS BETWEEN SPIRAL CABLE AND ICC UNIT

1. Disconnect ICC unit connector.
2. Check continuity between spiral cable M53 terminal 31 (G), 26 (G/OR) and ICC unit harness connector B245 terminal 58 (GY/L), 49 (B/Y).

31 - 58, 26 - 49

Continuity should exist.

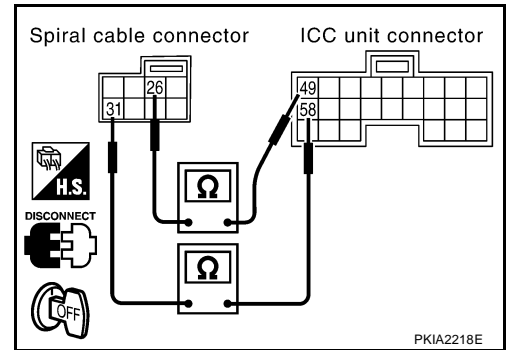

3. Check continuity between ICC unit harness connector B245 terminal 58 (GY/L), 49 (B/Y) and ground.

58, 49 - Ground

Continuity should not exist.

OK or NG

- NG >> Repair harness. Erase between spiral cable switch and ICC unit. Erase DTC, and perform self-diagnosis of ICC system again.
- OK >> GO TO 10.

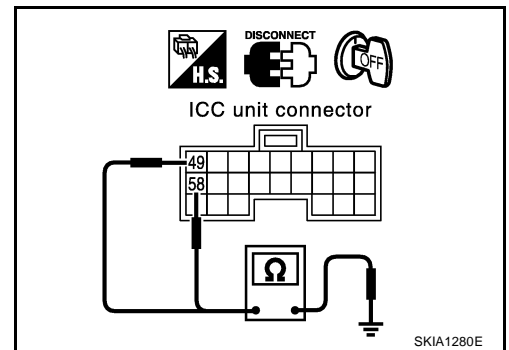

9. CHECK CONNECTOR FOR ICC UNIT

- Check ICC unit (on ICC unit and harness) for disconnected and bent terminals.

OK or NG

- OK >> Replace ICC unit. Erase DTC, and perform self-diagnosis of ICC system again.
- NG >> Repair terminal or connector. Erase DTC, and perform self-diagnosis of ICC system again.

10. CHECK CONNECTOR ICC STEERING SWITCH, SWITCH HARNESS AND SPIRAL CABLE

- Check ICC steering switch and combination switch terminals (on switch, on cable, on harness) for disconnection and bend.

OK or NG

- OK >> GO TO 9.
- NG >> Repair terminal or connector. Erase DTC and perform self-diagnosis of ICC system again.

Symptom 2: The ICC System Cannot Be Set (ON/OFF Switch Turns on/Off). EKS00302

The ICC cannot be set in the following cases.

- When the vehicle speed is not in range of approx. 25 MPH (40 km/h) to 90 MPH (144 km/h).
- When the A/T shift lever is in gears other than 'D'.
- While the brake is in operation.

A
B
C
D
E
F
G
H
I
J
L
M

ACS

1. CHECK OF CAUSE OF AUTOMATIC CANCELLATION

With CONSULT-II

1. With "CAUSE OF AUTO-CANCEL" in work support, check if any cause of cancellation exists.

OK or NG

- OK >> ● Cancel with appropriate cause.
- For causes A, B, or C, go to specified diagnosis.
- A: "OPE SW VOLT CIRC" : Refer to [ACS-73, "DTC 46 OPERATION SW CIRC"](#) .
- B: "VHCL SPD UNMATCH" : Refer to [ACS-69, "DTC 41 VHCL SPEED SE CIRC"](#) .
- C: "IGN LOW VOLT" : Refer to [ACS-68, "DTC 31 POWER SUPPLY CIR 1, DTC 34 POWER SUPPLY CIR 2"](#) .
- NG >> GO TO 2.

2. SELF-DIAGNOSIS CHECK

With CONSULT-II

1. Perform CONSULT-II self-diagnosis to check for malfunctioning items.

OK or NG

- OK >> After repairing or replacing malfunctioning part, erase DTC. Perform ICC system running test, and then perform self-diagnosis of ICC system again.
- NG >> GO TO 3.

3. SWITCHES AND VEHICLE SPEED SIGNAL CHECK

With CONSULT-II

1. With data monitor, check that switches and vehicle speed signal operate normally. Refer to [ACS-58, "DATA MONITOR"](#) .
- A: VHCL SPEED SE B: D RANGE SW
C: BRAKE SW D: SET/COAST SW

OK or NG

- OK >> After replacing ICC unit, erase DTC. Perform ICC system running test, and then perform self-diagnosis of ICC system again.
- NG >> ● A: Refer to [ACS-69, "DTC 41 VHCL SPEED SE CIRC"](#) .
- B: Refer to [ACS-95, "Symptom 4: The ICC System Is Not Cancelled When the Gear Is in Other Than 'D'."](#) .
 - C: Refer to [ACS-71, "DTC 45 BRAKE SW/STOP L SW"](#) .
 - D: Refer to [ACS-73, "DTC 46 OPERATION SW CIRC"](#) .

Symptom 3: The ICC System Cannot Be Cancelled by the CANCEL Switch, RESUME or Increase the Set Vehicle Speed, or Change the Distance Setting.

EKS003Q3

RESUME does not function in the following cases:

- When ON/OFF switch is turned off once.
- When the vehicle speed is less than 25 MPH (40 km/h).

1. SWITCH CHECK

With CONSULT-II

1. With data monitor, check that switches operate normally. "RESUME/ACC SW", "CANCEL SW", "DISTANCE ADJ". Refer to [ACS-58, "DATA MONITOR"](#) .

OK or NG

- NG >> [ACS-73, "DTC 46 OPERATION SW CIRC"](#)
- OK >> After replacing ICC unit, erase DTC. Perform driving check, and then perform self-diagnosis of ICC system again.

Symptom 4: The ICC System Is Not Cancelled When the Gear Is in Other Than 'D'.

EKS003Q4

1. D RANGE SWITCH CHECK**④ With CONSULT-II**

1. With data monitor, check that "D RANGE SW" operates normally. Refer to [ACS-58, "DATA MONITOR"](#).
 NG or OK

NG >> GO TO 2.

OK >> After replacing ICC unit, erase DTC. Perform ICC system running test, and then perform self-diagnosis of ICC system again.

2. CAN COMMUNICATION INSPECTION**④ With CONSULT-II**

1. With CONSULT-II self-diagnosis, check that "CAN COMM CIRCUIT" item exists.

OK or NG

OK >> Refer to [ACS-68, "DTC 20 CAN COMM CIRCUIT"](#).

NG >> GO TO 3.

3. D RANGE SWITCH CHECK

1. With TCM data monitor, check that "D" position switch operates normally.

OK or NG

NG >> After repairing or replacing malfunctioning part, erase DTC. Perform ICC system running test, and then perform self-diagnosis of ICC system again.

OK >> After replacing ICC unit, erase DTC. Perform ICC system running test, and then perform self-diagnosis of ICC system again.

Symptom 5: Chime Does Not Sound.

EKS003Q5

The chime may not sound occasionally in the following cases even if the distance from the vehicle ahead is short:

- When the speed difference from that of the vehicle ahead is small (both vehicles driving at similar speed).
- When the vehicle ahead drives at faster speed (the actual distance is increasing).
- When depressing the accelerator.
- Chime does not sound when the vehicle is not driving.
- Chime does not sound when the system does not detect any vehicle ahead. (Diagnose the conditions under which the system is detecting the vehicle ahead and when the system is malfunctioning. If there is any malfunction in detecting the vehicle ahead, check the system following the [ACS-97, "Symptom 8: The ICC System Frequently Cannot Detect the Vehicle Ahead/The Detection Zone Is Short."](#)

1. CHECK ICC WARNING CHIME

1. With active test, check that ICC warning chime operates normally.

OK or NG

OK >> Determine preceding vehicle detection status when malfunction occurred. If chime should have sounded: after replacing ICC unit, erase DTC. Perform ICC system running test, and then perform self-diagnosis of ICC system again.

NG >> GO TO 2.

2. CHECK ICC WARNING CHIME SIGNAL

1. Check the voltage between the ICC warning chime harness connector M37 terminals 1 (BR/W), 2 (Y) and ground.

- | | |
|-------------------|---|
| 1 - Ground | : Battery voltage (Approx. 12V)
(Ignition switch ON ON)
: Approx. 0V (Ignition switch ON OFF) |
| 2 - Ground | : Battery voltage (Approx. 12V)
(Chime output OFF)
: Approx. 0V (Chime output ON) |

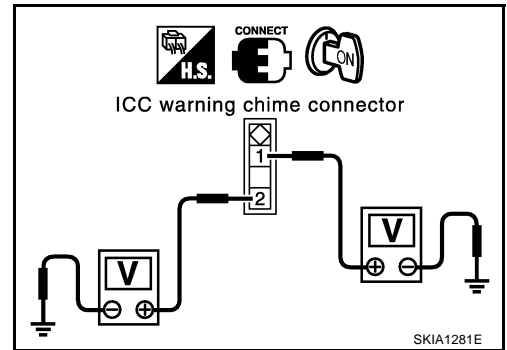

OK or NG

OK >> GO TO 4.

NG >> ● If terminal 1 is NG

: Check corresponding harness, connector, and fuse. After repairing, erase DTC. Perform. After that, perform self-diagnosis of ICC system.

● If terminal 2 is NG

: GO TO 3.

3. CHECK HARNESS BETWEEN ICC UNIT AND CHIME

1. Turn ignition switch OFF.
2. Disconnect connectors of ICC unit and ICC warning chime.
3. Check for continuity between ICC unit harness connector B243 terminal 21 (Y) and ICC warning chime harness connector M37 terminal 2 (Y).
4. Check for continuity between ICC unit harness connector B243 terminal 21 (Y) and ground.

- | | |
|--------------------|---------------------------------------|
| 21 - 2 | : Continuity should exist. |
| 21 - Ground | : Continuity should not exist. |

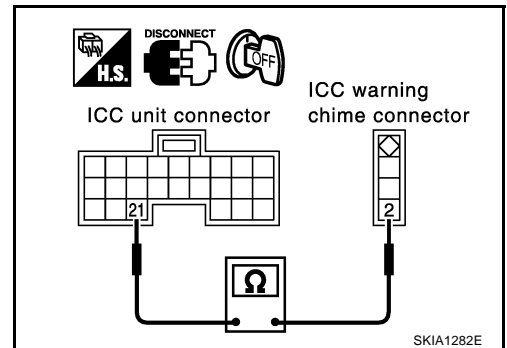

OK or NG

NG >> Check harness between ICC unit and ICC warning chime. After repairing, erase DTC. Perform ICC system running test, and then perform self-diagnosis of ICC system again.

OK >> GO TO 5.

4. CHECK CONNECTOR ICC WARNING CHIME

1. Check chime terminals (chime side and harness side) for disconnection, bend, and other irregular conditions.

OK or NG

OK >> After replacing chime, erase DTC. Perform ICC system running test, and then perform self-diagnosis of ICC system again.

NG >> After repairing terminal and connector, erase DTC. Perform driving check, and then perform self-diagnosis of ICC system again.

5. CHECK CONNECTOR FOR ICC UNIT

1. Check ICC unit terminals (ICC unit side and harness side) for disconnection, bend, and other irregular conditions.

OK or NG

OK >> GO TO 4.

NG >> After repairing terminal and connector, erase DTC. Perform ICC system running test, and then perform self-diagnosis of ICC system again.

Symptom 6: Chime Does Not Stop.

EKS003Q6

1. CHECK ICC WARNING CHIME SIGNAL

1. Check voltage between ICC warning chime harness connector M37 terminal 2 (Y) and ground.

**2 - Ground: Battery voltage (Approx. 12V)
(Chime output OFF: Approx. 0V)**

NOTE:

With active test, turn ON and OFF chime output.

OK or NG

- OK >> After replacing chime, erase DTC. Perform ICC system running test, and then perform self-diagnosis of ICC system again.
- NG >> GO TO 2.

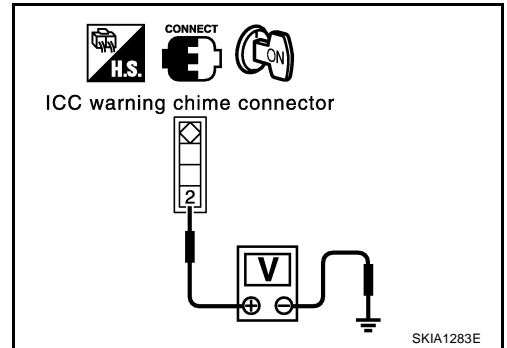

2. CHECK GROUND CIRCUIT FOR ICC WARNING CHIME

1. Turn ignition switch OFF.
2. Disconnect ICC warning chime and ICC unit connector.
3. Check for continuity between ICC warning chime harness connector M37 terminal 2 (Y) and ground.

Continuity should not exist.

OK or NG

- OK >> After replacing chime, erase DTC. Perform ICC system running test, and then perform self-diagnosis of ICC system again.
- NG >> Repair harness between ICC unit and chime. After repairing, erase DTC. Perform ICC system running test, and then perform self-diagnosis of ICC system again.

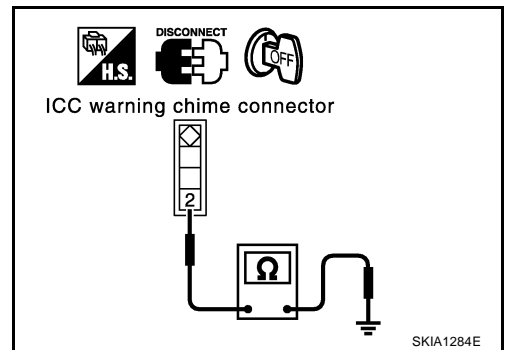

Symptom 7: Driving Force Is Hunting.

EKS003Q7

1. CHECK ASCD ACTUATOR

1. Check ASCD actuator. Refer to [ACS-100, "ASCD Actuator"](#).

OK or NG

- NG >> After repairing applicable parts, erase DTC. Perform ICC system running test, and then perform self-diagnosis of ICC system again.
- OK >> [ACS-97, "Symptom 8: The ICC System Frequently Cannot Detect the Vehicle Ahead/The Detection Zone Is Short."](#) Refer to

Symptom 8: The ICC System Frequently Cannot Detect the Vehicle Ahead/The Detection Zone Is Short.

EKS003Q8

The detection function may become unstable in the following cases:

- When the reflector of the vehicle ahead is deficient/ not clean enough to reflect the radar.
- When driving a road with extremely sharp corners.
- When the radar cannot detect the reflector of the vehicle ahead as the vehicle ahead is passing a hill or passing the peak.

1. VISUAL CHECK

1. Check ICC sensor body window for contamination and foreign materials.

OK or NG

- OK >> If any contamination or foreign materials are found, remove them. Then perform ICC system running test.
- NG >> GO TO 2.

A
B
C
D
E
F
G
H
I
J
L
M

ACS

2. OPERATION CHECK

1. After adjusting ICC sensor beam aiming, perform ICC system running test. Check that preceding vehicle detection performance has been improved.

OK or NG

OK >> Inspection is completed.

NG >> ● Replace ICC sensor, and perform laser ICC system running test beam aiming adjustment.

- After performing above, erase DTC. Perform ICC system running test, and then perform self-diagnosis of ICC system again.

Symptom 9: The System Does Not Detect the Vehicle Ahead at All.

EKS003Q9

1. VISUAL CHECK

1. With ignition switch turned ON (engine not started), check that all indicator lamps in ICC system display are continuously lit. (Check for a missing segment in preceding vehicle detection display.)

OK or NG

OK >> GO TO 2.

NG >> Check for combination meter. Refer to [DI-21, "ICC System Display Does Not Illuminate"](#) in DI.

2. VISUAL CHECK

- Check ICC sensor body window for contamination and foreign materials.

OK or NG

OK >> If any contamination or foreign materials are found, remove them. Perform ICC system running test.

NG >> GO TO 4.

3. VISUAL CHECK

- Check ICC sensor body window for cracks and scratches.

OK or NG

OK >> ● Replace ICC sensor, and perform laser beam aiming adjustment.

- After performing above, erase DTC. Perform ICC system running test, and then perform self-diagnosis of ICC system again.

NG >> GO TO 4.

4. ADJUST ICC SENSOR

1. After adjusting ICC sensor beam aiming, perform ICC system running test. Check that preceding vehicle detection performance has been improved.

OK or NG

OK >> Inspection is completed.

NG >> ● Replace ICC sensor, and perform laser ICC system running test beam aiming adjustment.

- After performing above, erase DTC. Perform ICC system running test, and then perform self-diagnosis of ICC system again.

ELECTRICAL COMPONENT INSPECTION

PFP:00000

ICC Steering Switch

EKS003RJ

1. Disconnect ICC steering switch.
2. Check resistance between M443 terminals 1 and 2 by depressing each switch.

Switch	Condition	Resistance [Ω]
ON/OFF	Depressed	Approx. 0
	Released	Approx. 5,456
DISTANCE	Depressed	Approx. 741
	Released	Approx. 5,456
ACCELERATE/ RESUME	Depressed	Approx. 2,586
	Released	Approx. 5,456
COAST/SET	Depressed	Approx. 1,406
	Released	Approx. 5,456
CANCEL	Depressed	Approx. 309
	Released	Approx. 5,456

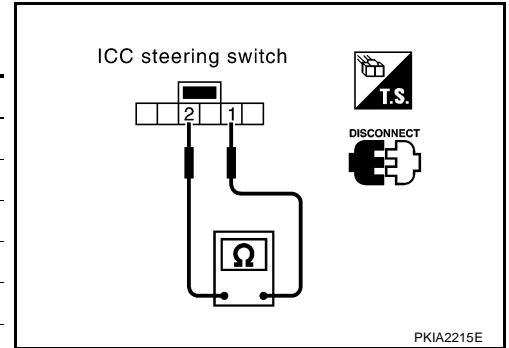

ICC Brake Switch and Stop Lamp Switch

EKS003QB

Condition	Continuity	
	ICC brake switch	Stop lamp switch
When brake pedal is depressed	No	Yes
When brake pedal is released	Yes	No

Check each switch after adjusting brake pedal, refer to [BR-6](#), "[BRAKE PEDAL](#)".

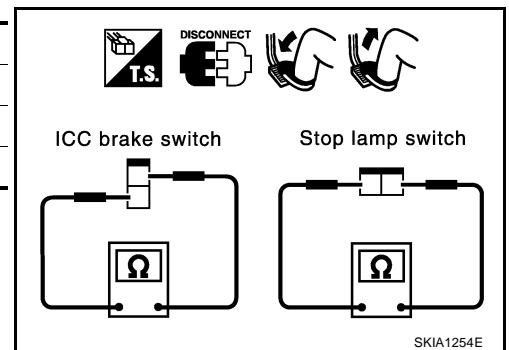

Booster Solenoid

EKS003QC

Disconnect booster solenoid/release switch connector, and check resistance value between terminals 4 and 6.

4 - 6 :Approx. 1.4 Ω

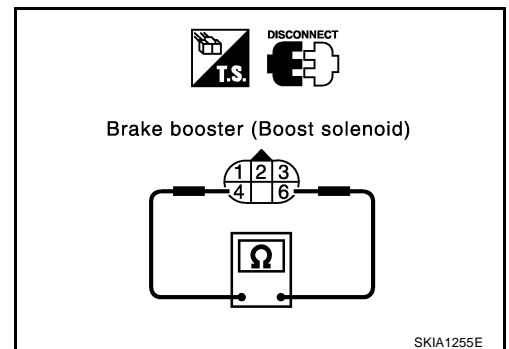

A
B
C
D
E
F
G
H
I
J
ACS
L
M

Release Switch

EKS003QD

Disconnect booster solenoid/release switch connector and check resistance between the terminals.

Condition	1 - 3	1 - 2	2 - 3
Release the brake pedal.	Continuity should exist.	Continuity should not exist.	Continuity should not exist.
Depress the brake pedal.	Continuity should not exist. (Note)	Continuity should exist. (Note)	Continuity should not exist.

(Note): However, if pedal is depressed insufficiently, resistance value may remain unchanged.

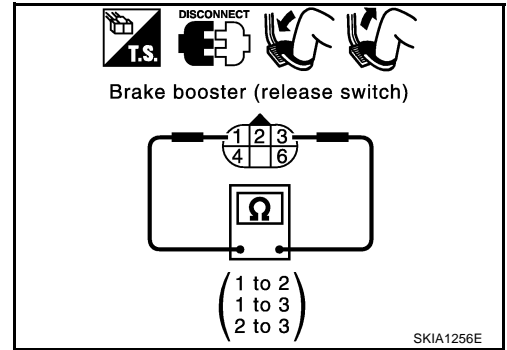

ASCD Actuator

EKS003QE

1. Disconnect vacuum hose from ASCD actuator.
2. Connect the hose of hand vacuum pump to ASCD actuator.

Apply -40 kPa (-0.41 kg/cm^2 , -5.8 psi) vacuum to ASCD actuator with hand vacuum pump.

ASCD wire should move to pull throttle drum.

Wait 10 seconds and check for decrease in vacuum pressure.

Vacuum pressure decrease:

Less than 2.7 kPa (0.028 kg/cm^2 , 0.39 psi)

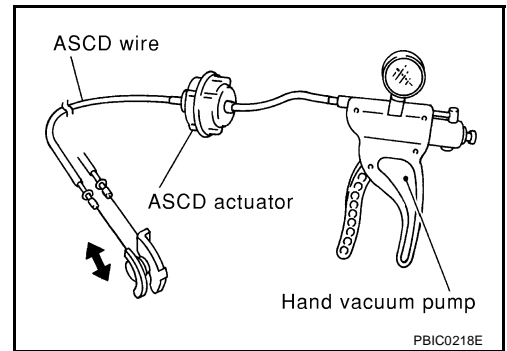

Vacuum Hose

EKS003QF

Check vacuum hose (between ASCD actuator and ASCD pump) for breakage, cracks or fracture.

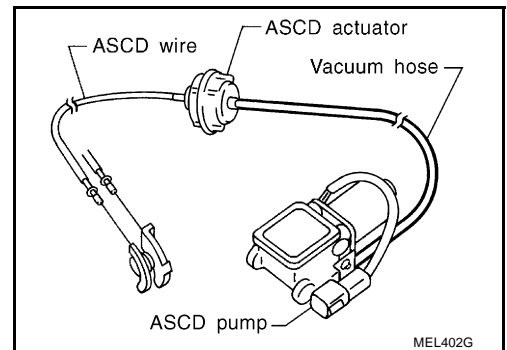

ASCD Pump

EKS003QG

1. Disconnect vacuum hose from ASCD pump and ASCD pump harness connector.
2. If necessary remove ASCD pump.
3. Connect vacuum gauge to ASCD pump.
4. Apply 12V direct current to ASCD pump and check operation.

ELECTRICAL COMPONENT INSPECTION

[ICC]

	12V direct current supply terminals		Operation
	(+)	(-)	
Air valve	1	2	Close
Release valve		3	Close
Vacuum motor		4	Operate

A vacuum pressure of at least – 40 kPa (– 0.41 kg/cm² , – 5.8 psi) should be generated.

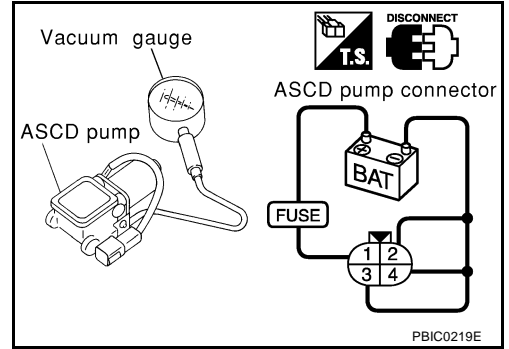

A
B
C
D
E
F
G
H
I
J
L
M

ACS

REMOVAL AND INSTALLATION

[ICC]

REMOVAL AND INSTALLATION

PFP:00000

ICC Unit

EKS003QH

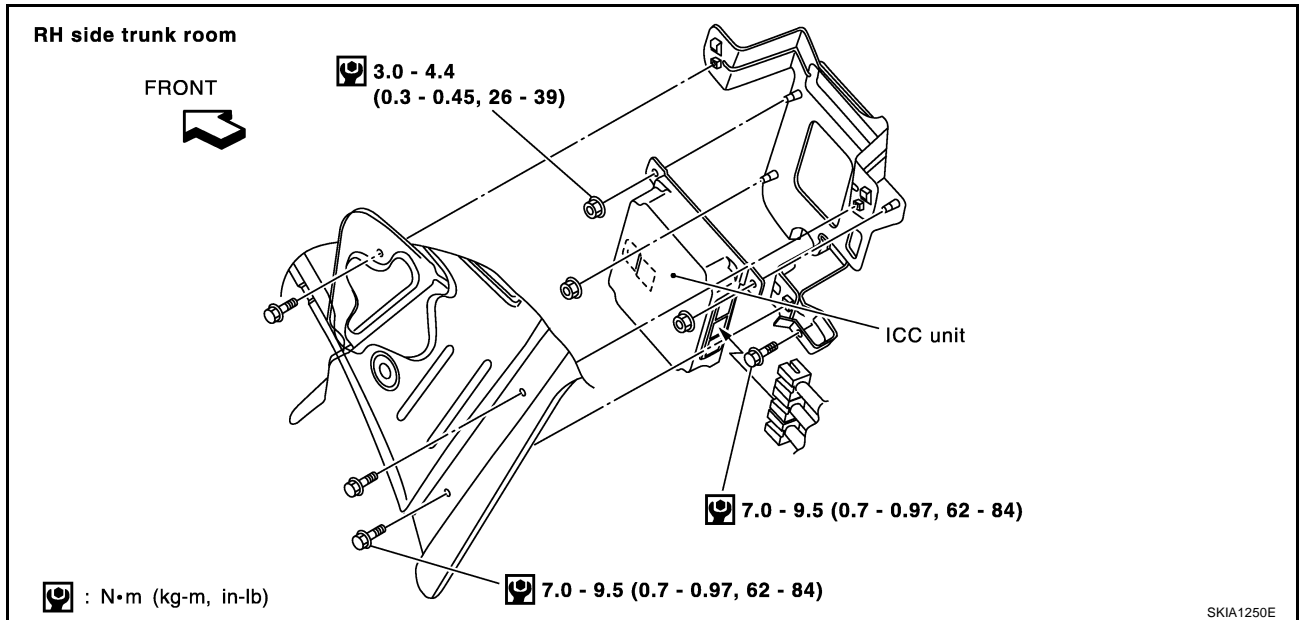

ICC Sensor

EKS003QI

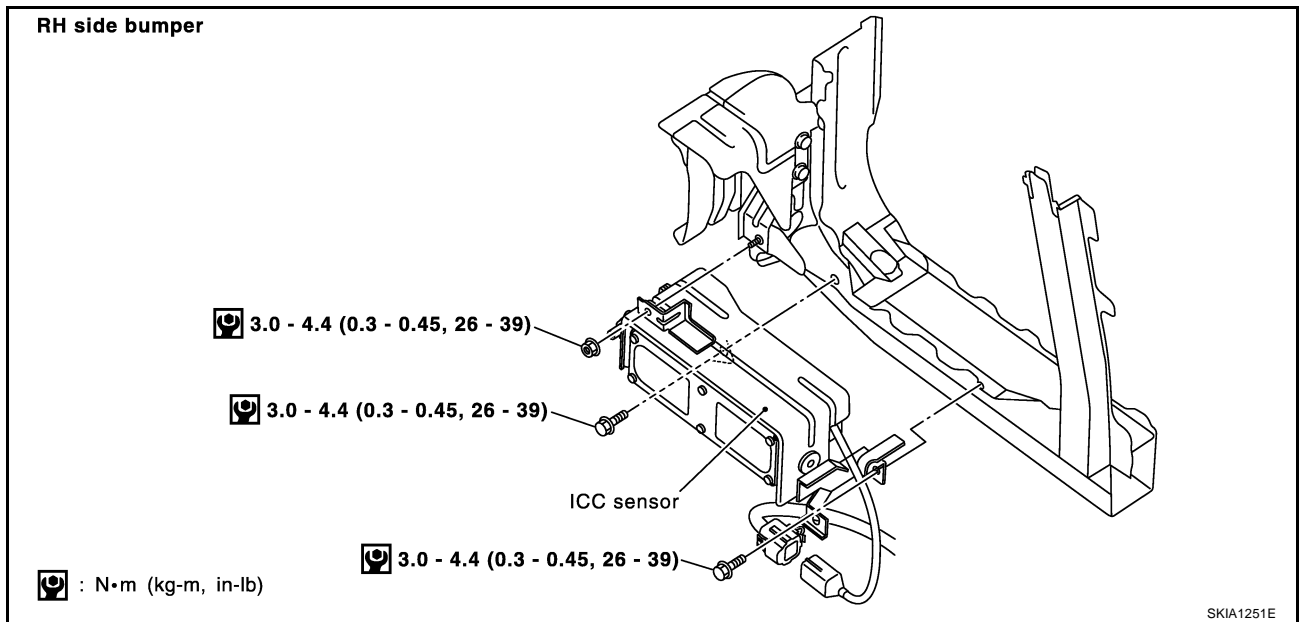

ICC Warning Chime

EKS003QJ

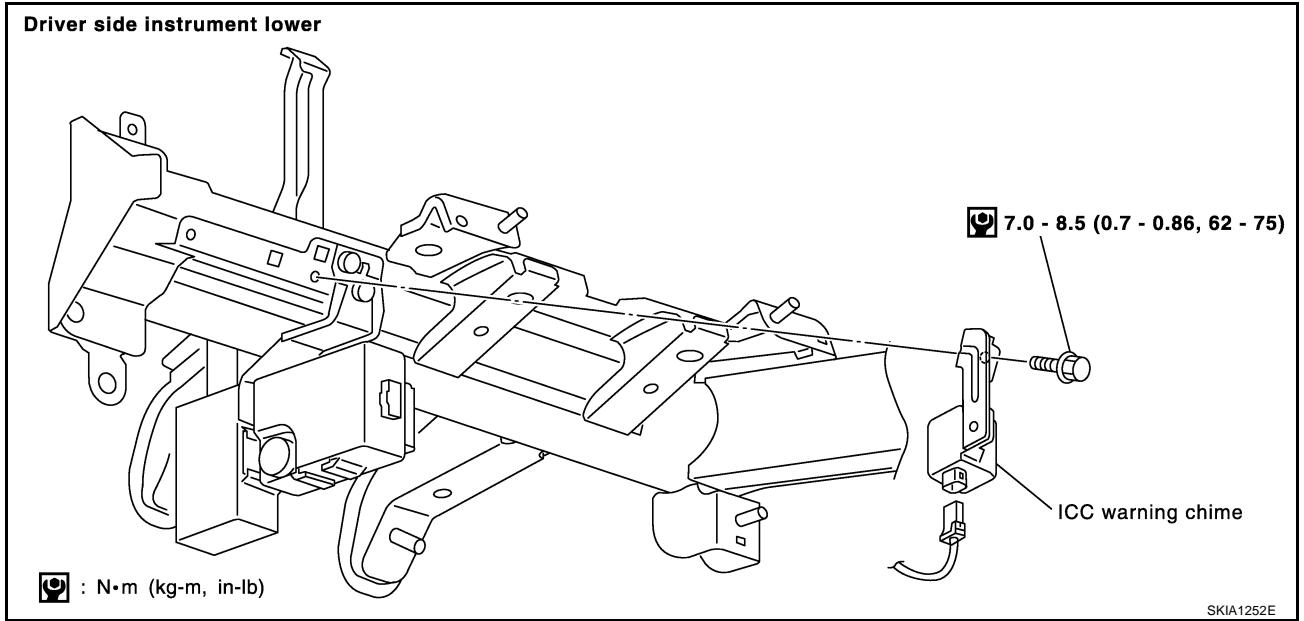

ICC Steering Switch

EKS003QK

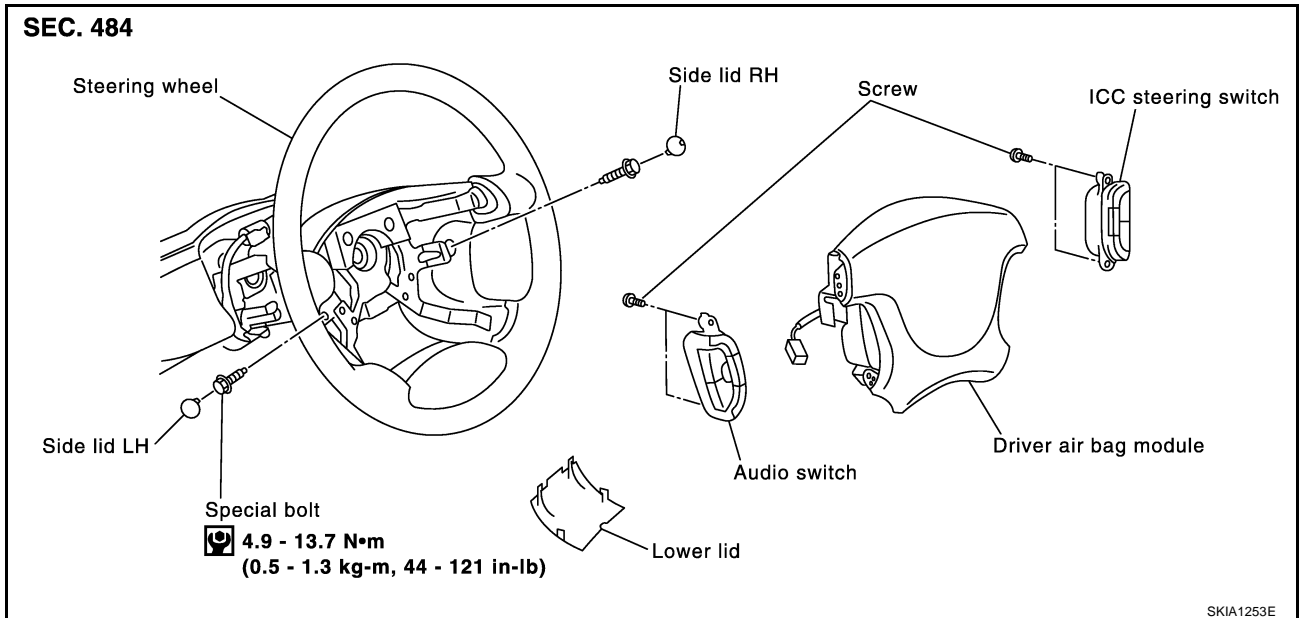

A
B
C
D
E
F
G
H
I
J
K
L
M

ACS

ASCD Wire Adjustment

EKS003QL

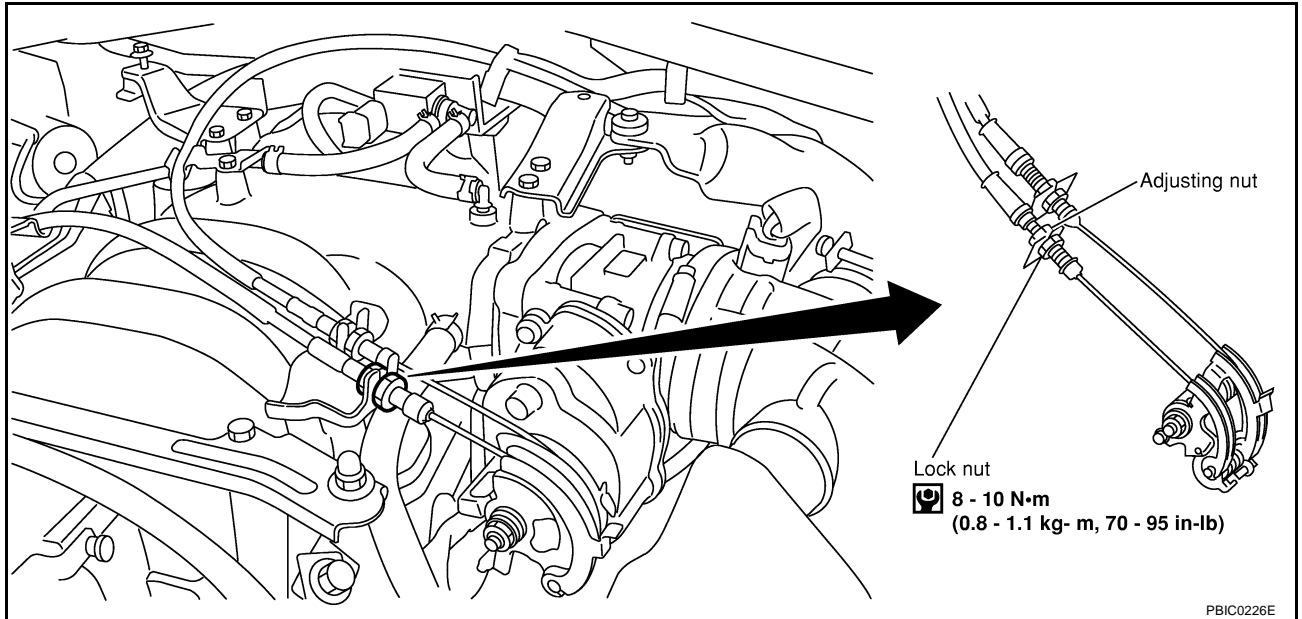
**CAUTION:**

- Be careful not to twist ASCD wire when removing it.
- Do not tense ASCD wire excessively during adjustment.

Adjust the tension of ASCD wire in the following manner.

1. Loosen lock nut and adjusting nut.
2. Make sure that accelerator wire is properly adjusted. Refer to [ACC-2, "ACCELERATOR CONTROL SYSTEM"](#).
3. Tighten adjusting nut just until throttle drum starts to move.
4. Loosen adjusting nut again 1/2 to 1 turn.
5. Tighten lock nut to specified torque holding the adjusting nut.

SERVICE DATA AND SPECIFICATIONS (SDS)

[ICC]

SERVICE DATA AND SPECIFICATIONS (SDS)

PPF:00030

Standard and Limit

EKS005QA

Turning back of ASCD cable adjusting nut	1/2 - 1.0 turns (From position throttle drum just starts to move)
--	---

Tightening Torque

EKS005QB

Unit: N·m (kg-m, ft-lb)
Unit: N·m (kg-m, in-lb)*

ACSD cable lock nut		8 - 10 (0.8 - 1.1, 70 - 95)*
ASCD actuator	Bolt	4.4 - 5.8 (0.45 - 0.59, 39 - 51)*
	Nut	10.8 - 13.7 (1.1 - 1.3, 8 - 10)
ICC unit		7.0 - 9.5 (0.70 - 0.97, 62 - 84)*

A
B
C
D
E
F
G
H
I
J
L
M

ACS

