

SECTION BR
BRAKE SYSTEM

A
 B
 C
 D
 E
BR
 G
 H
 I
 J
 K
 L
 M

CONTENTS

PRECAUTIONS	3	INSTALLATION	13
Precautions for Supplemental Restraint System (SRS) "AIR BAG" and "SEAT BELT PRE-TENSIONER"	3	Disassembly and Assembly	14
Precautions for Brake System	3	DISASSEMBLY	14
PREPARATION	4	INSPECTION AFTER DISASSEMBLY	16
Commercial Service Tools	4	ASSEMBLY	16
NOISE, VIBRATION AND HARSHNESS (NVH)		BRAKE BOOSTER	21
TROUBLESHOOTING	5	On-Vehicle Service	21
NVH Troubleshooting Chart	5	OPERATING CHECK	21
BRAKE PEDAL	6	AIRTIGHT CHECK	21
Inspection and Adjustment	6	Removal and Installation	21
PLAY AND CLEARANCE BETWEEN BRAKE PEDAL AND FLOOR PANEL WITH PEDAL DEPRESSED	6	REMOVAL	21
ADJUSTMENT	7	INSPECTION AFTER REMOVAL	21
Removal and Installation	7	INSTALLATION	22
COMPONENT PARTS DRAWING	7	FRONT DISC BRAKE	23
REMOVAL	8	Components	23
INSPECTION AFTER REMOVAL	8	Inspection	24
INSTALLATION	8	PAD WEAR INSPECTION	24
BRAKE FLUID	9	Pad Replacement	24
Checking Brake Fluid Level	9	REMOVAL	24
Checking Brake Line	9	INSTALLATION	25
Drain and Refill	9	Caliper Removal and Installation	26
Bleeding Brake System	10	REMOVAL	26
BRAKE PIPING AND HOSE	11	INSTALLATION	26
Hydraulic Circuit	11	Caliper Disassembly and Assembly	26
Front Brake Piping and Hose	11	DISASSEMBLY	26
REMOVAL	11	CALIPER INSPECTION	27
INSTALLATION	11	DISC ROTOR INSPECTION	27
Rear Brake Piping and Hose	12	ASSEMBLY	28
REMOVAL	12	Brake Burnishing Procedure	29
INSTALLATION	12	REAR DISC BRAKE	30
Inspection	12	Component	30
BRAKE MASTER CYLINDER	13	Inspection	31
Components	13	PAD THICKNESS	31
Removal and Installation	13	Pad Replacement	31
REMOVAL	13	REMOVAL	31
		INSTALLATION	32
		Caliper Removal and Installation	32
		REMOVAL	32

INSTALLATION	32	General Specifications	36
Caliper Disassembly and Assembly	33	Brake Pedal	36
DISASSEMBLY	33	Check Valve	36
INSPECTION AFTER DISASSEMBLY	33	Brake Booster	36
DISC ROTOR INSPECTION	34	Front Disc Brake	36
ASSEMBLY	34	Rear Disc Brake	36
SERVICE DATA AND SPECIFICATIONS (SDS)	36		

PRECAUTIONS

PRECAUTIONS

PF0:00001

Precautions for Supplemental Restraint System (SRS) “AIR BAG” and “SEAT BELT PRE-TENSIONER”

EFS00281

The Supplemental Restraint System such as “AIR BAG” and “SEAT BELT PRE-TENSIONER”, used along with a front seat belt, helps to reduce the risk or severity of injury to the driver and front passenger for certain types of collision. This system includes seat belt switch inputs and dual stage front air bag modules. The SRS system uses the seat belt switches to determine the front air bag deployment, and may only deploy one front air bag, depending on the severity of a collision and whether the front occupants are belted or unbelted. Information necessary to service the system safely is included in the SRS and SB section of this Service Manual.

WARNING:

- To avoid rendering the SRS inoperative, which could increase the risk of personal injury or death in the event of a collision which would result in air bag inflation, all maintenance must be performed by an authorized NISSAN/INFINITI dealer.
- Improper maintenance, including incorrect removal and installation of the SRS, can lead to personal injury caused by unintentional activation of the system. For removal of Spiral Cable and Air Bag Module, see the SRS section.
- Do not use electrical test equipment on any circuit related to the SRS unless instructed to in this Service Manual. SRS wiring harnesses can be identified by yellow and/or orange harnesses or harness connectors.

Precautions for Brake System

EFS000NL

- Recommended fluid is brake fluid “DOT 3”.
- Never reuse drained brake fluid.
- Be careful not to splash brake fluid on painted areas.
- To clean or wash all parts of master cylinder, disc brake caliper and wheel cylinder, use clean brake fluid.
- Never use mineral oils such as gasoline or kerosene. They will ruin rubber parts of hydraulic system.
- Use flare nut wrench when removing and installing brake tube.
- When installing brake piping, be sure to torque.
- Before working, turn ignition switch OFF and disconnect connectors for VDC actuator and control unit or battery negative terminals.
- Burnish brake contact surfaces after refinishing or replacing drums or rotors, after replacing pads or linings, or if a soft pedal occurs at very low mileage. Refer to [BR-29, "Brake Burnishing Procedure"](#).

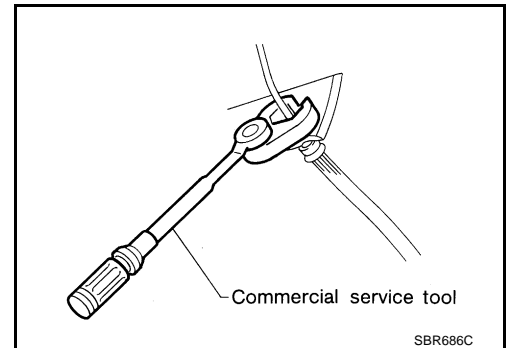

WARNING:

- Clean brake pads and shoes with a waste cloth, then wipe with a dust collector.

PREPARATION

PREPARATION

PFP:00002

Commercial Service Tools

EFS000NK

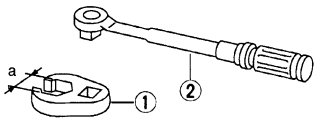
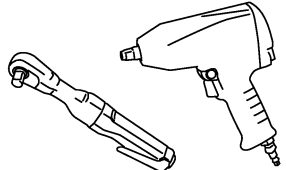
Tool name	Description
<p>1. Flare nut crowfoot a: 10 mm (0.39 in) 2. Torque wrench</p>  <p>S-NT360</p>	<p>Removing and installing each brake piping</p>
<p>Power tool</p>  <p>PBIC0190E</p>	<p>Removing front and rear caliper assembly</p>

BRAKE PEDAL

BRAKE PEDAL

PF:46501

Inspection and Adjustment

EFS000FQ

PLAY AND CLEARANCE BETWEEN BRAKE PEDAL AND FLOOR PANEL WITH PEDAL DEPRESSED

1. Check brake pedal free height from dash floor panel.
2. Adjust height referring to following specifications.

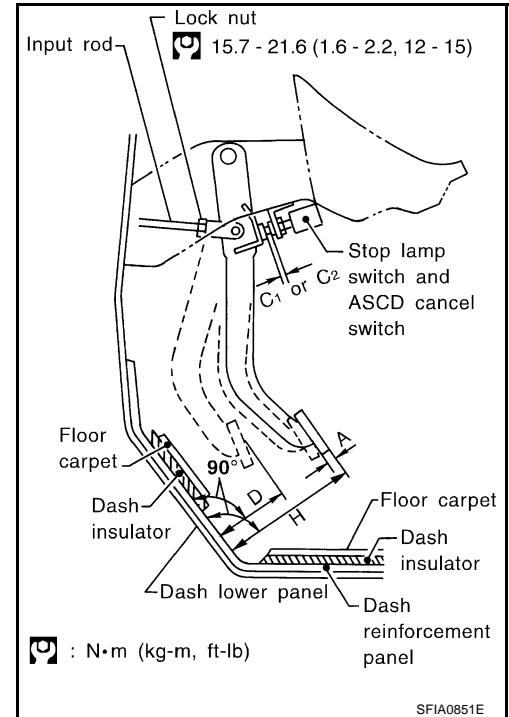

H	Brake pedal height	192.4 - 202.4 mm (7.57 - 7.97 in)
D	Depressed pedal height (under a force of 490 N (50 kg, 110lb) with engine running)	90 mm (3.54 in) or more
C1 or C2	Clearance between stopper rubber and threaded end of stop lamp switch and ASCD cancel switch.	0.74 - 1.96 mm (0.0291 - 0.0772 in)
A	Pedal play	3 - 11 mm (0.12 - 0.43 in)

BRAKE PEDAL

ADJUSTMENT

1. Loosen stop lamp switch and ASCD cancel switch by rotating it counterclockwise by 45°.
2. Loosen lock nut (A) on the input rod, then rotate input rod to set pedal to the specified height, and tighten lock nut (A).

CAUTION:

Check that threaded end of input rod stays inside clevis.

Lock nut (A) :

15.7 - 21.6 N·m(1.6 - 2.2 kg·m, 12 - 15 in·lb)

3. With the pedal pulled and held by hand, press stop lamp switch and ASCD cancel switch until its threaded end contacts stopper rubber.
4. With the threaded end of stop lamp switch contacting stopper rubber and ASCD cancel switch, rotate switch clockwise by 45° to secure.

CAUTION:

Make sure that clearance (C) between stopper rubber and threaded end of stop lamp switch and ASCD cancel switch is within standard.

5. Check pedal play.

CAUTION:

Make sure that stop lamps go off when pedal is released.

6. Start the engine to check brake pedal's depressed height.

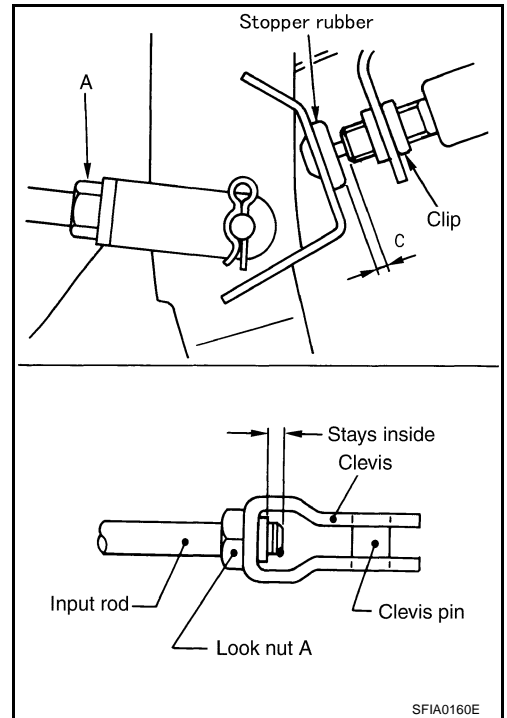

Removal and Installation COMPONENT PARTS DRAWING

EFS000FR

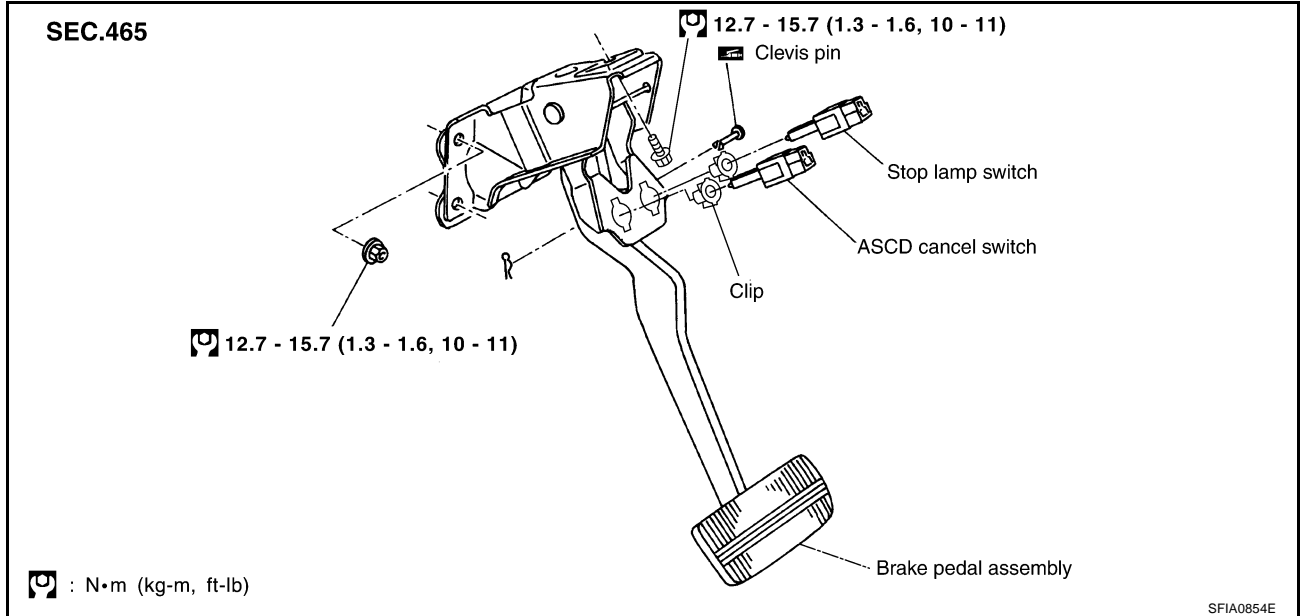

BRAKE PEDAL

REMOVAL

1. Remove lower driver-side instrument panel. Refer to [IP-16, "\(V\) Instrument Lower Driver Panel"](#) .
2. Remove steering column. Refer to [PS-11, "STEERING COLUMN"](#) .
3. Remove stop lamp switch and ASCD cancel switch from pedal assembly.
4. Remove snap pin and clevis pin from brake booster clevis.
5. Remove mounting nuts and bolts from bracket, and remove pedal assembly from vehicle.

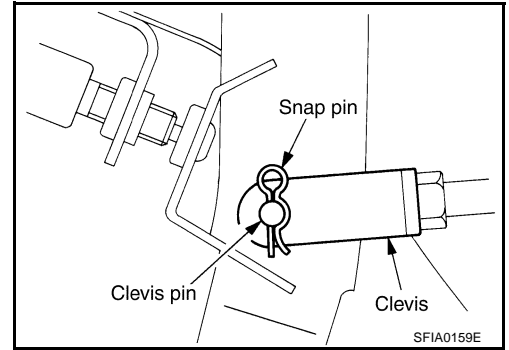

INSPECTION AFTER REMOVAL

- Check brake pedal for bend, damage, and cracks on welded parts. Replace applicable part if a failure is detected.
- Check clevis pin and resin stopper for damage and deformation. If a failure is detected, replace clevis pin.

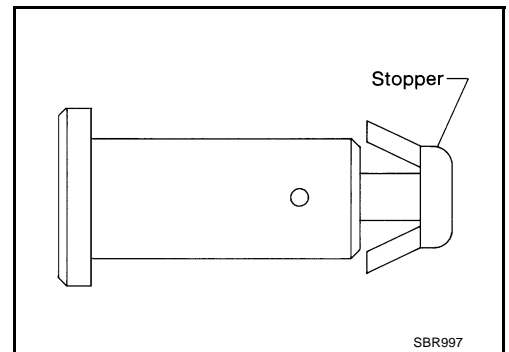

INSTALLATION

Paying attention to the following items, install in reverse order of removal.

- After installing brake pedal assembly to vehicle, adjust brake pedal.

BRAKE FLUID

BRAKE FLUID

PFP:KN100

Checking Brake Fluid Level

EFS0020Z

- Check fluid level in reservoir tank. It should be between Max and Min lines on reservoir tank.
- If fluid level is extremely low, check brake system for leaks.
- Release parking brake lever and see if brake warning lamp goes off. If not, check brake system for leaks.

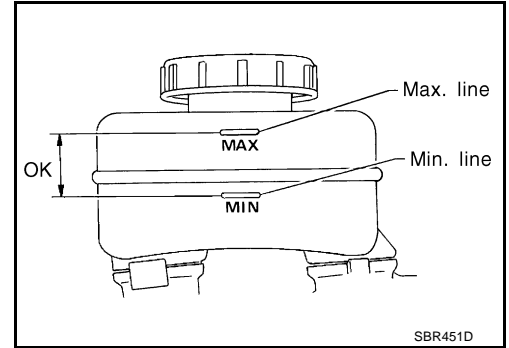

Checking Brake Line

EFS00210

CAUTION:

If leakage occurs around joints, retighten or, if necessary, replace damaged parts.

1. Check brake line (tubes and hoses) for cracks, deterioration or other damage. Replace any damaged parts.
2. Check for oil leakage by fully depressing brake pedal while engine is running.

CAUTION:

If leakage occurs around joints, retighten or, if necessary, replace damaged parts.

3. Check brake lines (tubes and hoses) for cracks, deterioration or other damage. Replace any damaged parts.
4. Check for oil leakage by fully depressing brake pedal while engine is running.

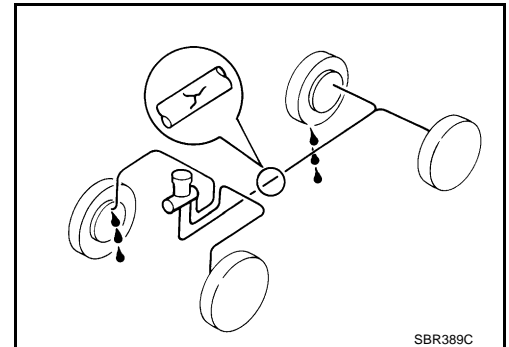

Drain and Refill

EFS002AU

CAUTION:

- Refill with new brake fluid "DOT3".
- Never reuse drained brake fluid.
- Do not let brake fluid come in contact with painted surfaces on the body. This might damage the paint, so if it does come in contact, immediately wipe area and wash off with water.

1. Connect a vinyl tube to bleed valve.
2. Depress the brake pedal, loosen the bleed valve, and gradually remove the brake fluid.
3. Turn the key switch to the off position and remove the negative battery cable.
4. Make sure there is no foreign material in the reservoir tank, and refill with new brake fluid.
5. Rest foot on brake pedal. Loosen bleed valve. Slowly depress pedal until it stops. Tighten bleed valve. Release brake pedal. Repeat this process a few times, then pause to add new brake fluid to master cylinder. Continue until new brake fluid flows out.
Bleed Air. Refer to [BR-10, "Bleeding Brake System"](#).

BRAKE FLUID

Bleeding Brake System

EFS00211

CAUTION:

- Carefully monitor brake fluid level at master cylinder during bleeding operation.
- Fill reservoir with new brake fluid "DOT 3". Make sure it is full at all times while bleeding air out of system.
- Place a container under master cylinder to avoid spillage of brake fluid.
- For models with VDC/TCS/ABS, turn ignition switch OFF and disconnect VDC actuator connectors or battery ground cable.

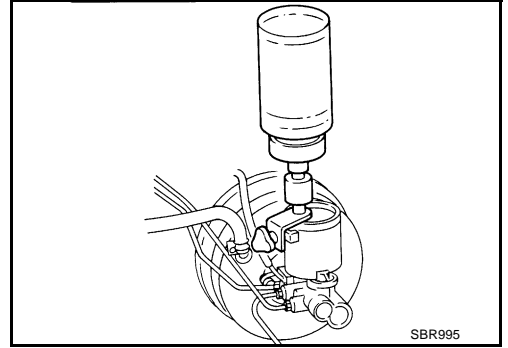

- Bleed air in the following order. Right rear brake → Left front brake → Left rear brake → Right front brake

1. Connect a transparent vinyl tube to bleed valve.
2. Fully depress brake pedal several times.
3. With brake pedal depressed, open bleed valve to release air.
4. Close bleed valve.
5. Release brake pedal slowly.
6. Repeat steps 2, through 5, until clear brake fluid comes out of bleed valve.

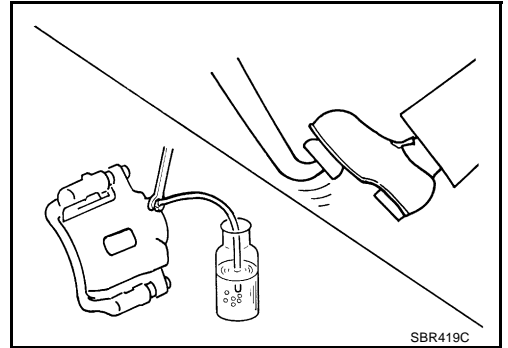

BRAKE PIPING AND HOSE

BRAKE PIPING AND HOSE

PF:46210

Hydraulic Circuit

EFS000FW

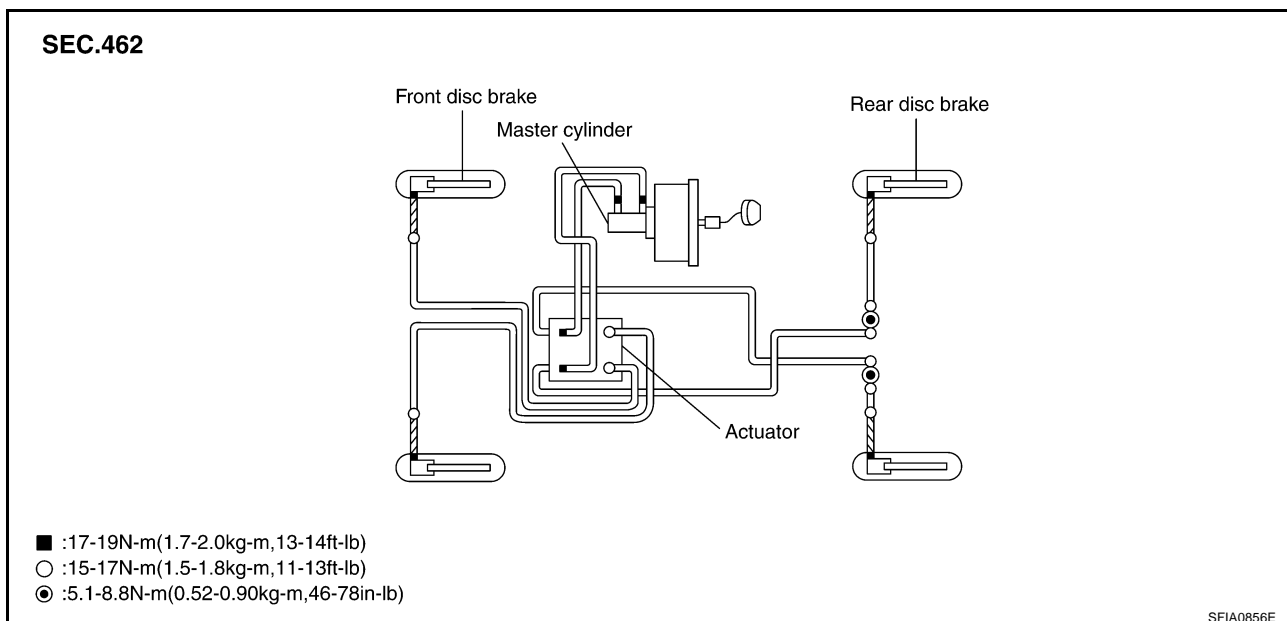

CAUTION:

- When installing, check for twist and fracture.
- Make sure that there is no interference with other parts when turning steering clockwise or counterclockwise.
- The brake piping is an important safety part. If a brake fluid leak is detected, always disassemble parts. Replace applicable part with a new one.

Front Brake Piping and Hose

EFS000FX

REMOVAL

1. Connect a vinyl tube to bleed valve.
2. Drain brake fluid gradually from bleed valve of each wheel while depressing brake pedal.
3. Cover the brake line connection to prevent foreign material such as dust or dirt from entering into the connection.
4. Using a flare nut wrench, remove brake tube from brake hose. Remove union bolt, and remove brake hose from caliper assembly.
5. Remove lock plate.
6. Remove mounting nuts, and remove brake hose from vehicle.

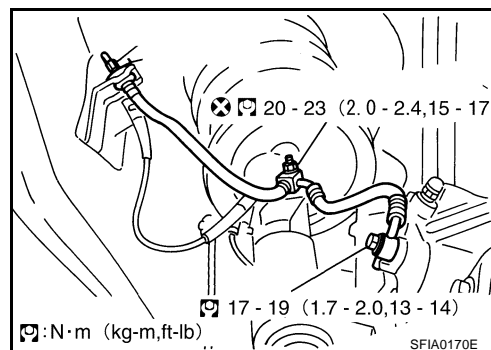

INSTALLATION

1. Install brake hose by aligning with protrusion on caliper assembly, and tighten union bolts to specified torque.

CAUTION:

- Do not reuse copper washer.
2. Install brake hose to brake tube on vehicle, and temporarily tighten flare nut by hand until it stops to install bracket. Fix it with lock plate, and tighten it to the specified torque.
 3. Install brake hose to vehicle, and tighten mounting nuts to the specified torque.
 4. After work, bleed air.

BRAKE PIPING AND HOSE

Rear Brake Piping and Hose REMOVAL

EFS000FY

1. Connect a vinyl tube to bleed valve.
2. Drain brake fluid gradually from bleed valve of each wheel while depressing brake pedal.
3. Cover the brake line connection to prevent foreign material such as dust or dirt from entering into the connection.
4. Using a flare nut wrench, remove brake tube from brake hose.
5. Remove union bolts, and then remove brake hose from caliper assembly.
6. Remove brake hose mounting bolts, and remove brake hose from vehicle.

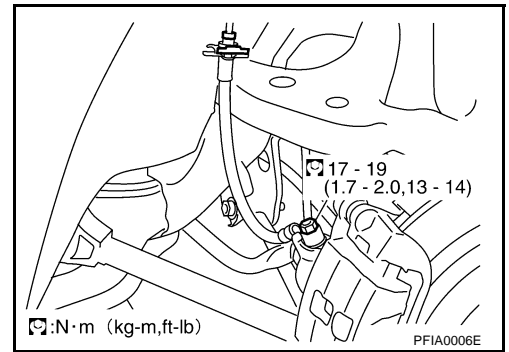

INSTALLATION

1. Install brake hose by aligning with protrusion on caliper assembly, and tighten union bolts to the specified torque.

CAUTION:

- Do not reuse the copper washer.
 - Refill with new brake fluid "DOT3".
 - Never reuse drained brake fluid.
2. Fix brake hose to vehicle. Temporarily tighten flare nut by hand until it stops, and tighten it to the specified torque.
 3. After work, bleed air.

Inspection

EFS000FZ

CAUTION:

If leak is detected at the connections, retighten it or replace damaged part if necessary.

1. Check hose, tube, and connections for fluid leaks, damage, twist, deformation, contact with other parts, and loose connections.
2. While depressing pedal under the force of 785 N (80 kg, 177 lb) with engine running for approximately 5 seconds, check for fluid leak from each part.

BRAKE MASTER CYLINDER

BRAKE MASTER CYLINDER

PFP:46010

Components

EFS0020U

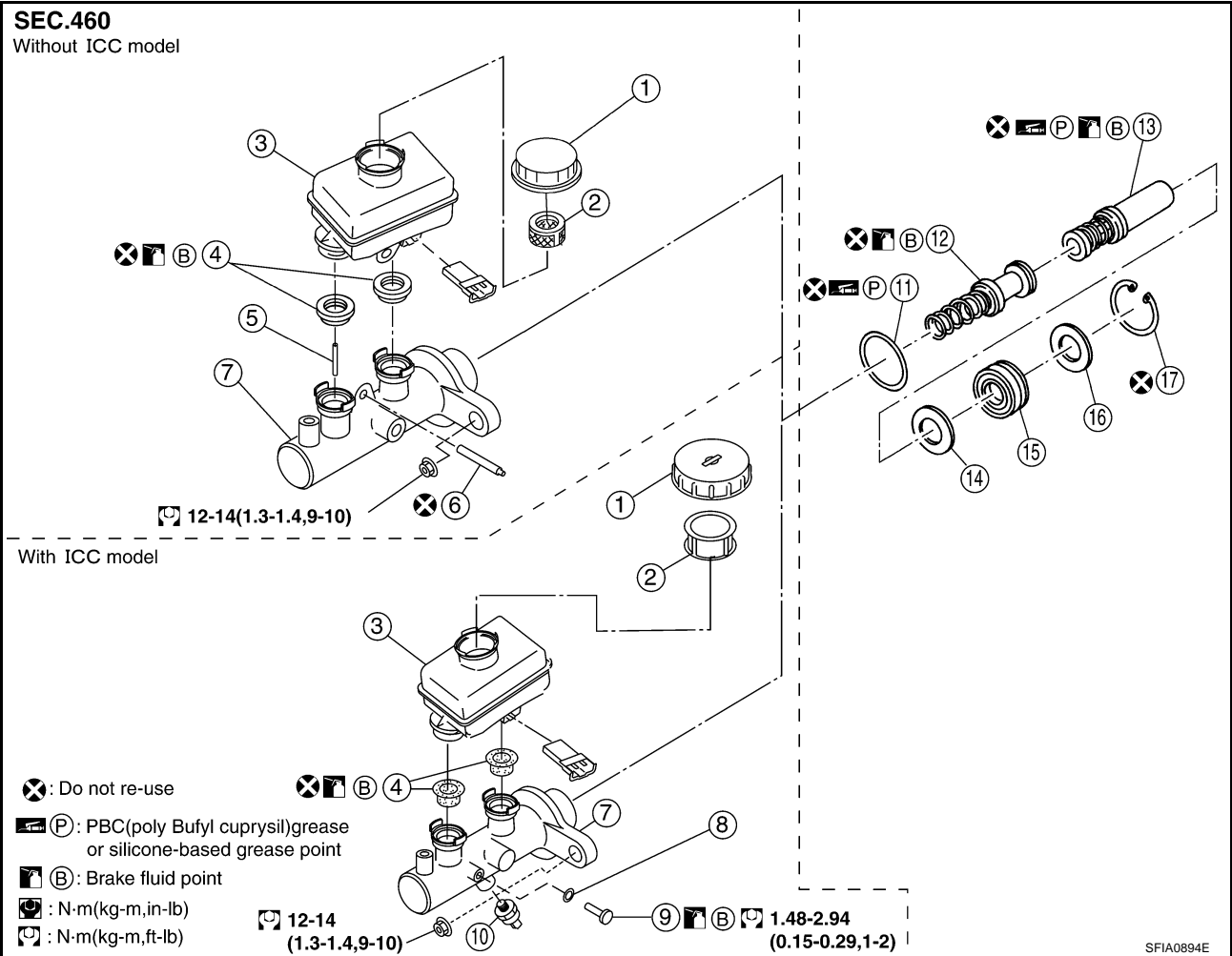

- | | | |
|-----------------------------|-------------------|-------------------------------|
| 1. Reservoir cap | 2. Oil filter | 3. Reservoir tank |
| 4. Seal | 5. Piston stopper | 6. Pin |
| 7. Cylinder body | 8. O-ring | 9. Piston stopper |
| 10. Pressure sensor | 11. O-ring | 12. Secondary piston assembly |
| 13. Primary piston assembly | 14. Plate | 15. Guide assembly |
| 16. Plate | 17. Snap-ring | |
- (Not inserted in some vehicles.)

Removal and Installation

REMOVAL

1. Drain brake fluid.
2. Remove the harness connectors for the fluid level sensor and pressure sensor.
3. Using a flare nut wrench, remove the brake tube from the master cylinder.
4. Remove the mounting nuts, and remove the master cylinder assembly from the vehicle.

INSTALLATION

CAUTION:

- Refill with new brake fluid "DOT3".
 - Never reuse drained brake fluid.
1. Temporarily tighten the flare nuts on the brake tube to master cylinder by hand.
 2. Install the master cylinder to the brake booster assembly, and tighten the mounting nuts to the specified torque.

EFS0020V

BRAKE MASTER CYLINDER

CAUTION:

- Do not damage and stain the rod of the primary piston.
- Do not reuse the O-ring seal, and primary piston.
- Apply silicon grease for the O-ring seal and primary piston.

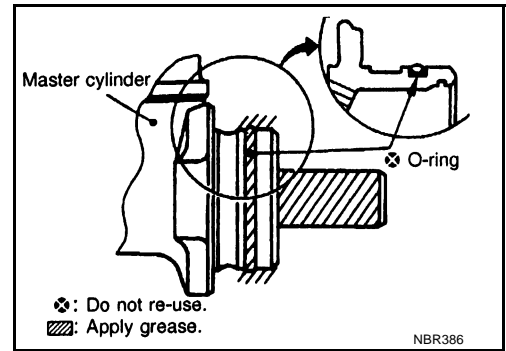

3. Using a flare nut torque wrench, tighten the flare nut on the brake tube to the specified torque.

 : 15 - 17 N·m (1.5 - 1.8 kg·m, 11 - 12 ft·lb)

4. Refill the new brake fluid and bleed air. Refer to [BR-10, "Bleeding Brake System"](#) .

Disassembly and Assembly

DISASSEMBLY

EFS0020W

Models without ICC

1. Tighten the flange of the cylinder body in base in the figure.

CAUTION:

- Pay attention to the orientation of master cylinder body.
- Use the copper plate or closes for fixing the body in the vise.

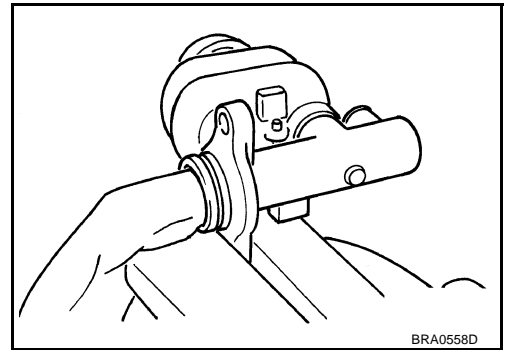

2. Using the pin-punch (commercial service tool: dia approx. 4mm), remove pin from the reservoir tank.
3. Remove the master cylinder assembly from the vise.
4. Remove the reservoir tank and grommet from the cylinder body.

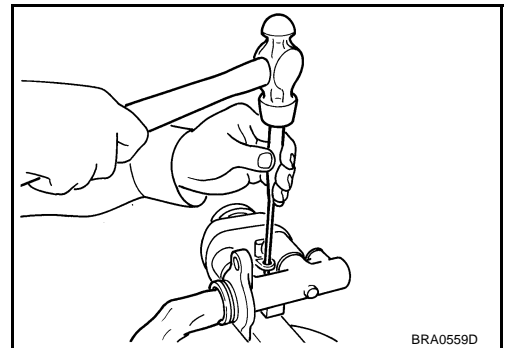

5. Push the primary piston and remove the stopper pin from secondary tank boss hole in the cylinder body.

CAUTION:

Be careful not to damage the inner wall of the cylinder.

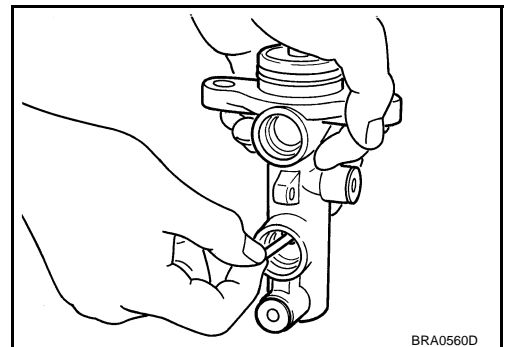

BRAKE MASTER CYLINDER

6. Remove the snap ring in pushing primary piston.

CAUTION:

Be careful not to put out the piston.

7. Holding the rod of the primary piston, remove the primary piston assembly, the plate and the guide with pulling straight to prevent the cup from being caught by the inner wall of the cylinder.
8. Remove the plate and the guide from the primary piston.

CAUTION:

Be careful not to damage the rod from the inner wall of the plate.

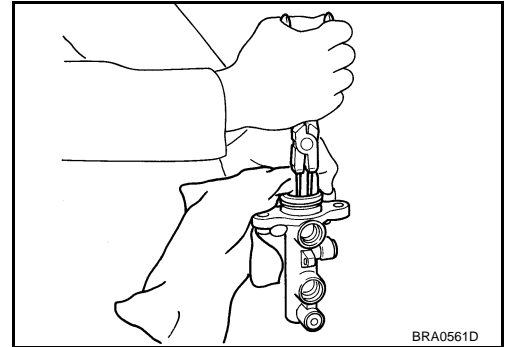

9. Tap the flange using a soft block such as wood, and carefully pull the secondary piston assembly straight out to prevent the inner wall of the cylinder from being damaged.

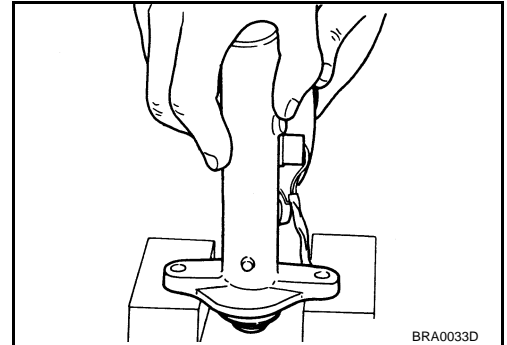

Models with ICC

CAUTION:

Be careful not to damage the rod of primary piston with covering cloths in acting.

1. Tighten the flange of the cylinder body in base in the figure.

CAUTION:

- Pay attention to the orientation of master cylinder body.
- Use the copper plate or closes for fixing the body in the vise.

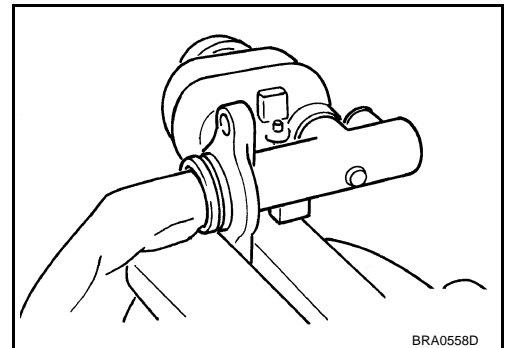

2. Push the primary piston and remove the piston stopper from secondary tank boss hole in the cylinder body.

CAUTION:

Be careful not to damage the inner wall of the cylinder.

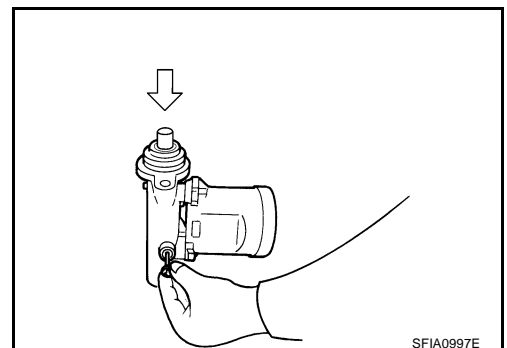

A
B
C
D
E
BR
G
H
I
J
K
L
M

BRAKE MASTER CYLINDER

3. Remove the snap ring in pushing primary piston.

CAUTION:

Be careful not to put out the piston.

4. Holding the rod of the primary piston, remove the primary piston assembly, the plate and the guide with pulling straight to prevent the cup from being caught by the inner wall of the cylinder.
5. Remove the plate and the guide from the primary piston.

CAUTION:

Be careful not to damage the rod from the inner wall of the plate.

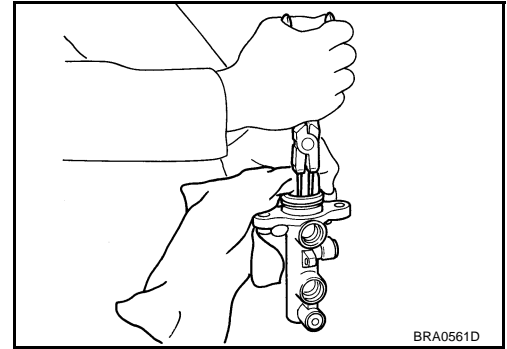

6. Tap the flange using a soft block such as wood, and carefully pull the secondary piston assembly straight out to prevent the inner wall of the cylinder from being damaged.

7. Remove the reservoir tank.

CAUTION:

Remove the reservoir tank only when necessary.

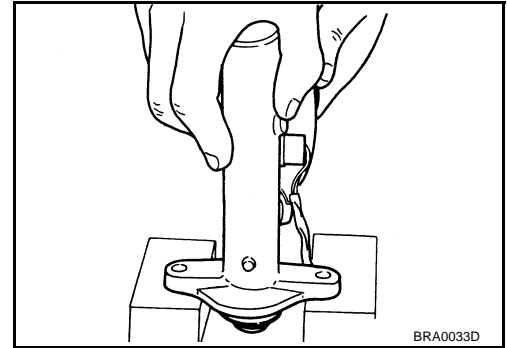

INSPECTION AFTER DISASSEMBLY

Inspect the next items.

Master Cylinder

- Check the inner wall of the cylinder for damage, wear, corrosion, and pin holes. Replace the cylinder if a malfunction is detected.

ASSEMBLY

CAUTION:

- Never use mineral oils such as kerosene or gasoline during the cleaning and assembly processes.
- Make sure that there is no foreign material such as dirt and dust on the inner wall of the cylinder, piston, and cup seal. Be careful not to damage the parts with a service tool when assembling.
- Do not drop the parts. Do not use any dropped parts.

Models without ICC

1. Apply brake fluid to the inner wall of cylinder body and contact surface of the piston assembly.
2. Insert secondary piston and primary piston assembly into cylinder body in this order.

CAUTION:

- Do not reuse the primary and secondary piston assemblies.
- Pay attention to the orientation of the piston cup, and insert straight to prevent the cup from being caught by the inner wall of the cylinder.
- Always replace the inner kit as an assembly.

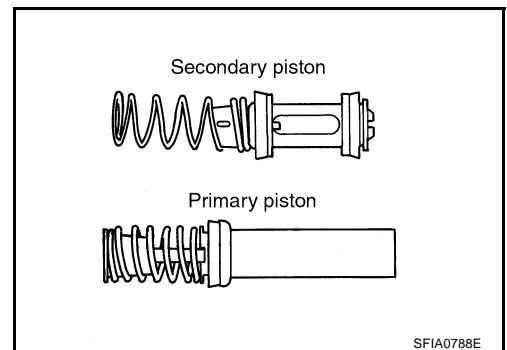

BRAKE MASTER CYLINDER

3. Align the slit in the center of the piston with the axial direction of the valve stopper to assemble. Visually check the secondary piston slit from the valve stopper mounting hole, and install the valve stopper.

CAUTION:

Always replace the piston pin O-ring with new one in the repair kit.

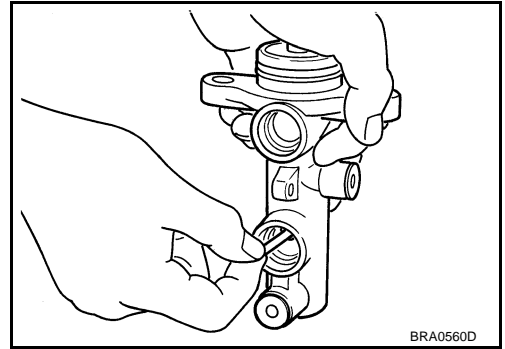

4. Insert the plate and the guide assembly into the cylinder body.

CAUTION:

- There are two kinds of the guide assembly and the plate. Shown in the figure and refer to [BR-13. "Components"](#).
- Be careful not to damage the rod of the primary piston.
- Pay attention to the orientation of the guide assembly.
- Do not drop the O-ring.

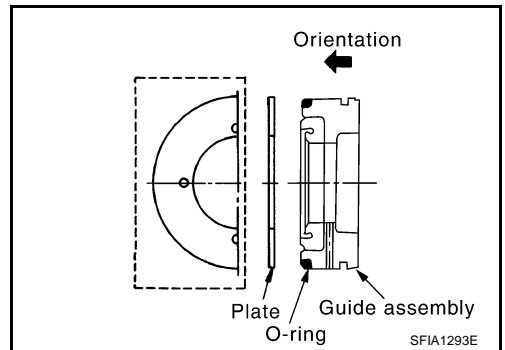
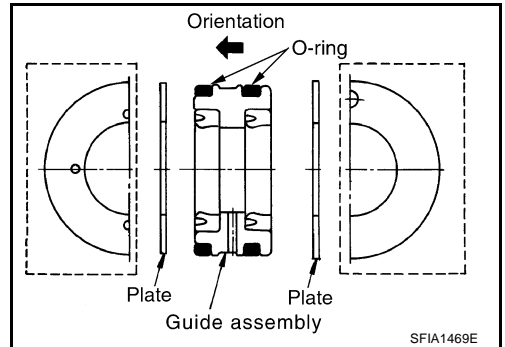

5. Be careful not to damage the rod of the primary piston with covering the close. Then insert snap ring to cylinder with pushing primary piston.

CAUTION:

- Be careful to check the snap ring in the inner tip of the cylinder body.
- Don not reuse the snap ring.

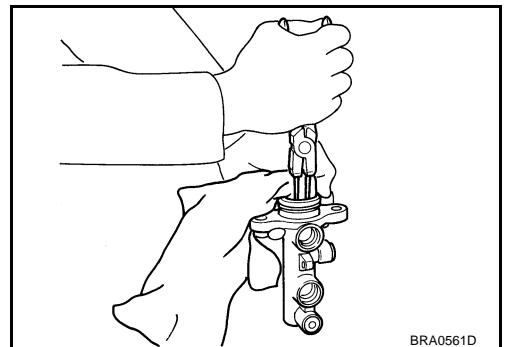

6. Tithing the flange of the cylinder body in the figure.

CAUTION:

- Using the copper plate or closes to cover the flange for fixing base.
- Pay attention to the orientation of the cylinder body.

7. Apply brake fluid to a grommet, and press it into the master cylinder to install.

CAUTION:

Do not reuse the grommet.

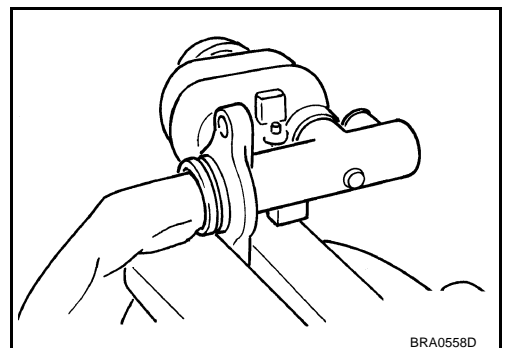

A
B
C
D
E
BR
G
H
I
J
K
L
M

BRAKE MASTER CYLINDER

8. Install the reservoir tank to the master cylinder.

CAUTION:

Pay attention to the orientation of the reservoir tank.

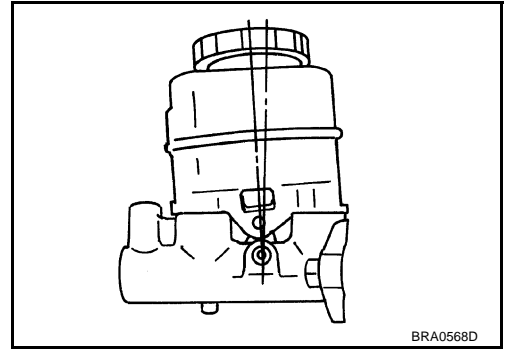

9. Set the reservoir tank in the front direction to the cylinder body. Press a new reservoir tank in the cylinder body.

CAUTION:

- Pay attention to the orientation of the piston cup, and insert straight to prevent the cup from being caught by the inner wall of the cylinder.

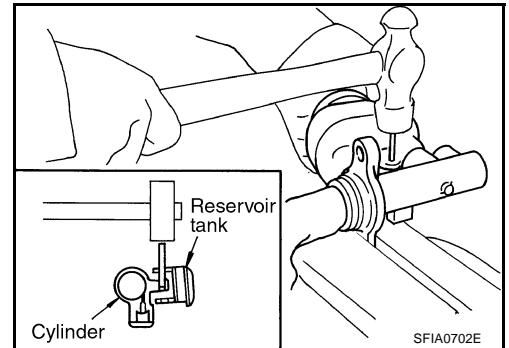

BRAKE MASTER CYLINDER

Models with ICC

1. Apply brake fluid to the inner wall of cylinder body and contact surface of the piston assembly.
2. Insert secondary piston and primary piston assembly into cylinder body in this order.

CAUTION:

- Do not reuse the primary and secondary piston assemblies.
- Pay attention to the orientation of the piston cup, and insert straight to prevent the cup from being caught by the inner wall of the cylinder.
- Always replace the inner kit as an assembly.

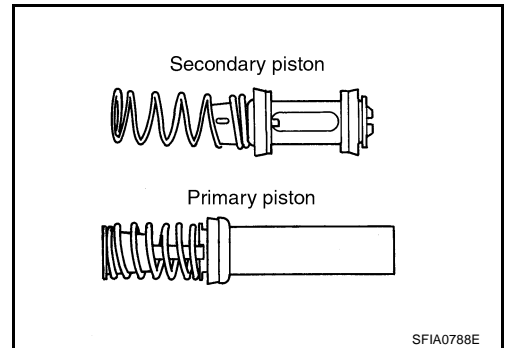

3. Insert the plate and the guide assembly into the cylinder body.

CAUTION:

- There are two kinds of the guide assembly and the plate. Shown in the figure and refer to [BR-13, "Components"](#).
- Be careful not to damage the rod of the primary piston.
- Pay attention to the orientation of the guide assembly.
- Do not drop the O-ring.

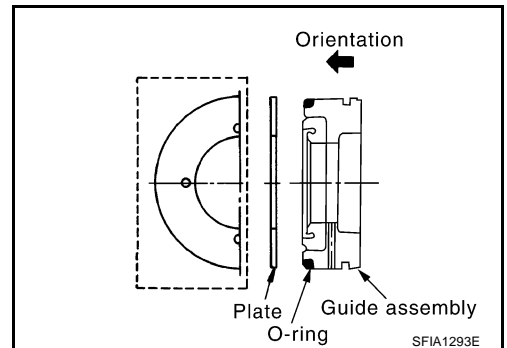
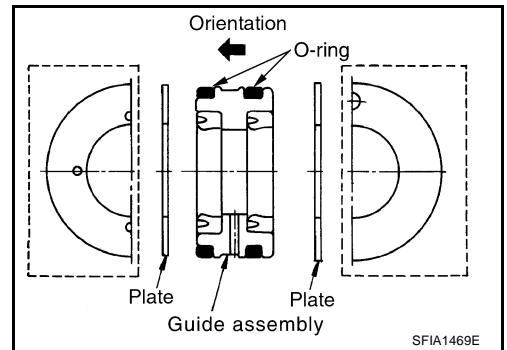

4. Be careful not to damage the rod of the primary piston with covering the close. Then insert snap ring to cylinder piston with pushing primary piston.

CAUTION:

- Be careful to check the snap ring in the inner tip of the cylinder body.
- Don not reuse the snap ring.

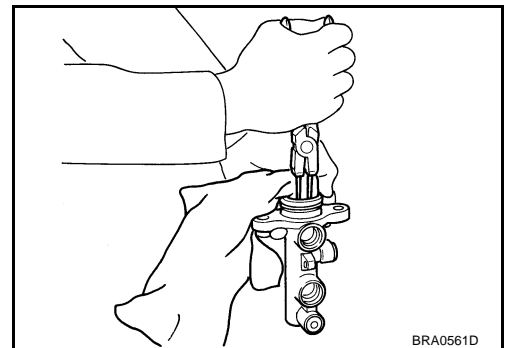

A
B
C
D
E
BR
G
H
I
J
K
L
M

BRAKE MASTER CYLINDER

5. Align the slit in the center of the piston with the axial direction of the piston stopper to assemble. Visually check the secondary piston slit from the piston stopper mounting hole, and install the valve stopper.

CAUTION:

Always replace the piston pin O-ring with new one in the repair kit.

6. Apply brake fluid to a grommet, and press it into the master cylinder to install.

CAUTION:

Do not reuse the grommet.

7. Press a new reservoir tank in the cylinder body.

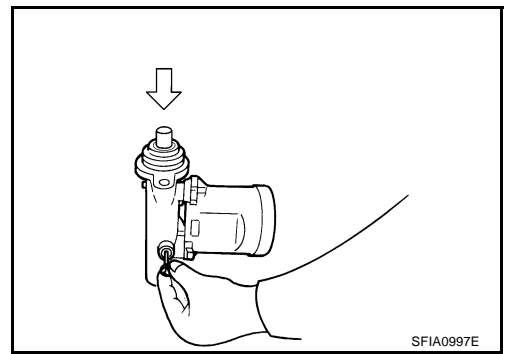

BRAKE BOOSTER

BRAKE BOOSTER

PFP:47200

On-Vehicle Service OPERATING CHECK

EFS0020X

With the engine stopped, change the vacuum to the atmospheric pressure by depressing the brake pedal several times. Then with brake pedal fully depressed, start the engine and when the vacuum pressure reaches the standard, check that the clearance between the brake pedal and floor panel decreases.

CAUTION:

Depressing pedal interval is approximately 5 seconds.

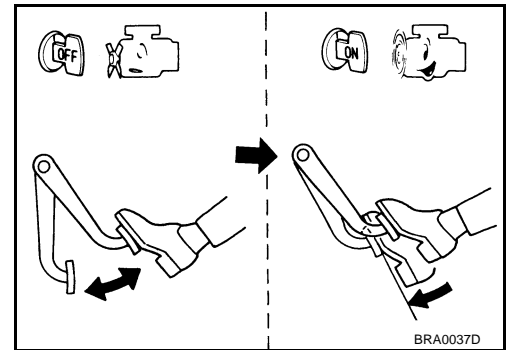

AIRTIGHT CHECK

- Run the engine at idle for approximately 1 minute, and stop it after applying vacuum to the booster. Depress the brake pedal normally to change the vacuum to the atmospheric pressure. Check that distance between the brake pedal and floor panel gradually increases.

CAUTION:

Depressing pedal interval is approximately 5 seconds.

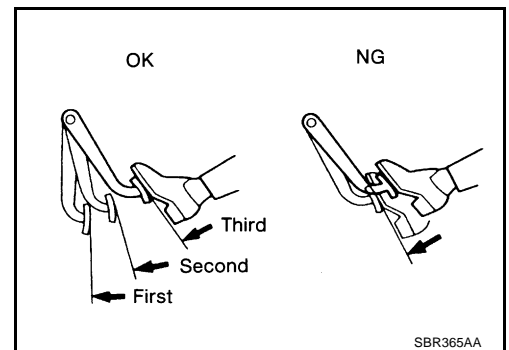

Removal and Installation REMOVAL

EFS0020Y

CAUTION:

- Be careful not to splash brake fluid on painted areas; it may cause paint damage. If brake fluid is splashed on painted areas, wash it away with water immediately.
 - Be careful not to deform or bend brake pipes, during removal of booster.
- Remove the vacuum hose from the brake booster.
 - Remove the master cylinder.
 - Remove the snap pin and clevis pin on the clevis in the passenger compartment, and remove the input rod from the brake pedal.
 - Remove the mounting nuts on the pedal bracket.
 - Remove the booster assembly from the engine compartment.

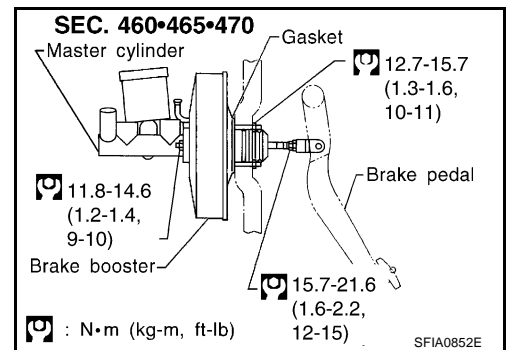

INSPECTION AFTER REMOVAL

Output Rod Length Inspection

- Using a handy vacuum pump, apply a vacuum of -66.7 kPa (-500 mmHg, 19.69 inHg) to the brake booster.
- Check output rod length.

Standard dimension when vacuum

-66.7 kPa (-500 mmHg, -19.69 inHg):

With VDC: -6.2 mm (-0.24 in)

With ICC: 10.4 mm (0.409 in)

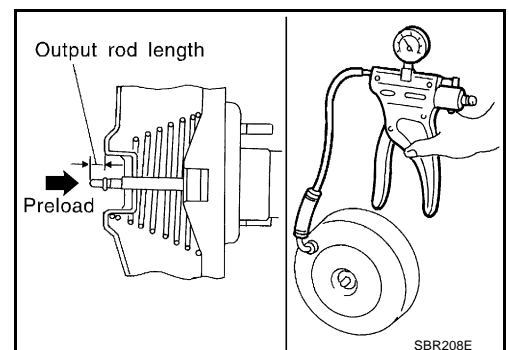

BRAKE BOOSTER

INSTALLATION

1. Loosen the lock nut to adjust the input rod length so that the length "B" (in the figure on the left) satisfies the specified value.

Length "B" : 125 mm (4.92 in)

2. After adjusting "B", temporarily tighten the lock nut to install the booster assembly to the vehicle. At this time, make sure to install a gasket between the booster assembly and the vehicle.
3. Connect the brake pedal with the clevis of the input rod.
4. Install the pedal bracket mounting nuts and tighten them to the specified torque.
5. Install the master cylinder to the booster assembly.
6. Adjust the height and play of the brake pedal.
7. Tighten the lock nut of the input rod to the specified torque.
8. Bleed air.

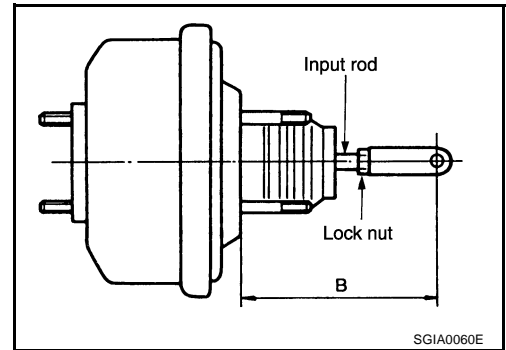

FRONT DISC BRAKE

FRONT DISC BRAKE

PFP:41000

Components

EFS000G8

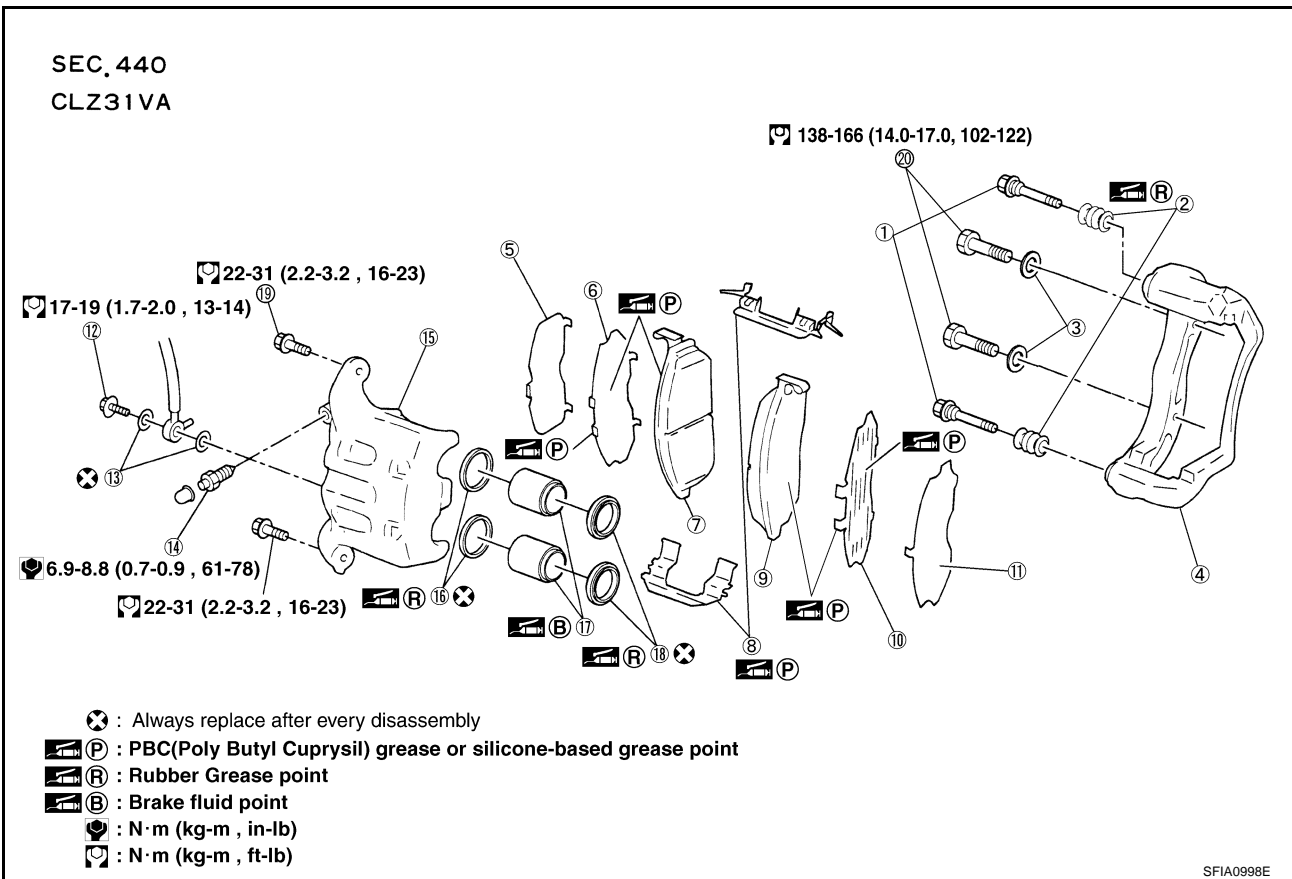

- | | | |
|----------------------|------------------------|-------------------|
| 1. Sliding pin | 2. Sliding pin boot | 3. Washer |
| 4. Torque member | 5. Inner shim cover | 6. inner shim |
| 7. Inner pad | 8. Pad retainer | 9. Outer pad |
| 10. Outer shim | 11. Outer shim cover | 12. Union bolt |
| 13. Copper washer | 14. Bleed valve | 15. Cylinder body |
| 16. Piston seal | 17. Piston | 18. Piston boot |
| 19. Sliding pin bolt | 20. Torque member bolt | |

CAUTION:

- Clean dust on caliper and brake pad with a vacuum dust collector. Do not blow with compressed air.
- While removing cylinder body, never depress brake pedal because piston will pop out.
- It is not necessary to remove mounting bolts on torque member and brake hose except for disassembly or replacement of caliper assembly. In this case, hang cylinder body with a wire so that brake hose is not under tension.
- Do not damage piston boot.
- Always replace shims and shim covers as a set when replacing brake pads.
- Keep brake fluid clean of rotor.

FRONT DISC BRAKE

Inspection

PAD WEAR INSPECTION

EFS000G9

- Remove wheel with vehicle lifted to check pad thickness from check hole on cylinder body. If necessary, use a scale to check.

Standard thickness : 10.0 mm (0.394 in)

Repair limit thickness : 2.0 mm (0.079 in)

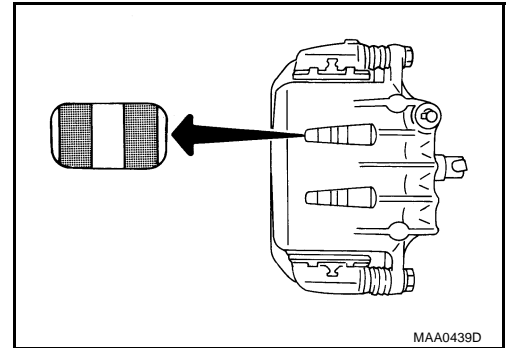

Pad Replacement REMOVAL

EFS000GA

WARNING:

Clean brake pads with a vacuum dust collector to minimize the hazard of airborne particles or other materials.

CAUTION:

- When cylinder body is open, do not depress brake pedal because piston will pop out.
 - Be careful not to damage piston boot or get oil on rotor always replace shims in replacing pads.
 - If shims are rusted or show peeling of rubber coat, replace them with new shims.
 - It is not necessary to remove connecting bolt except for disassembly or replacement of caliper assembly. In this case, suspend cylinder body with wire so as not to stretch brake hose.
 - Carefully monitor brake fluid level because brake fluid will return to reservoir when pushing back piston.
 - Burnish brake contact surfaces after refinishing or replacing drums or rotors, after replacing pads or linings, or if a soft pedal occurs at very low mileage. Refer to [BR-29, "Brake Burnishing Procedure"](#).
1. Remove master cylinder reservoir cap.
 2. Remove lower sliding pin bolt.

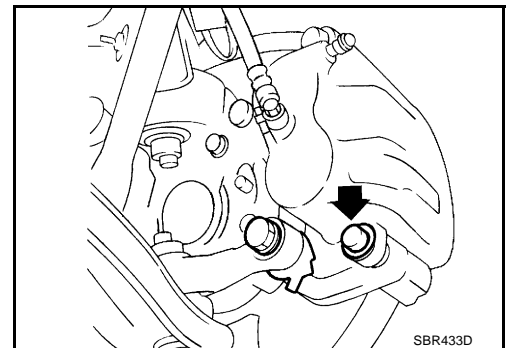

FRONT DISC BRAKE

3. Hang cylinder body with a wire, and remove pads, pad retainers, shims from torque member.

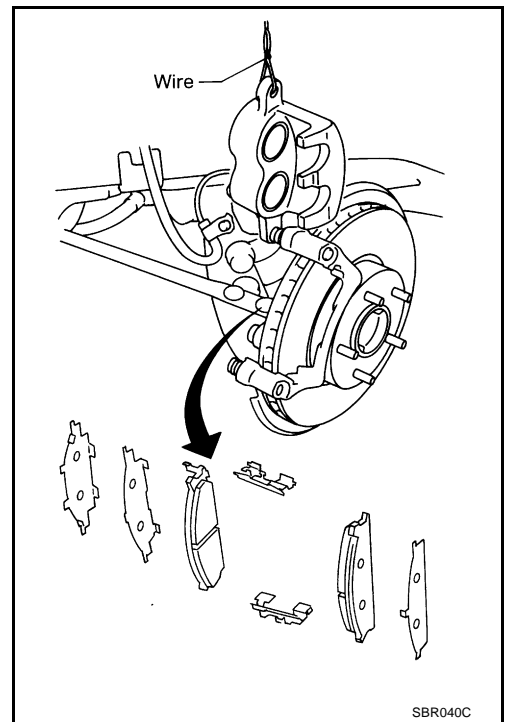

CAUTION:

- When removing pad retainer from torque member, lift pad retainer in the direction shown by arrow (shown in the figure) so as not to deform it.
- Do not damage piston boot.
- Keep brake fluid clean of rotor.

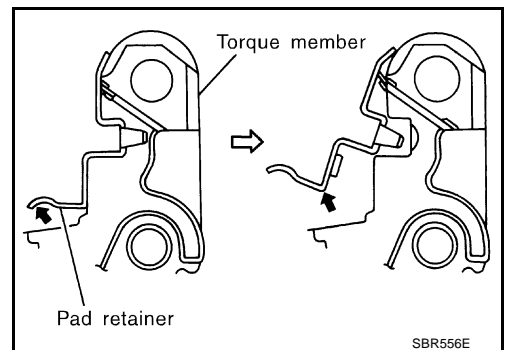

INSTALLATION

1. Apply brake grease to the back of pad and both sides of shim, install inner shim to inner pad, and outer shim and outer shim cover to outer pad.
2. Apply disc brake grease to pad contact surface on pad retainer, and install pad retainers and pads to torque member.

CAUTION:

The CLZ31VA inner pad and outer pad have pad-return mechanism on upper side of pad retainer. When installing CLZ31VA pad to torque member, be sure to install pad return lever to pad wear sensor securely.

3. Install cylinder body to torque member.

CAUTION:

When replacing pads with new ones, press in piston until pads can be installed. In this case, carefully monitor brake fluid level in reservoir tank because brake fluid will return to reservoir tank of master cylinder.

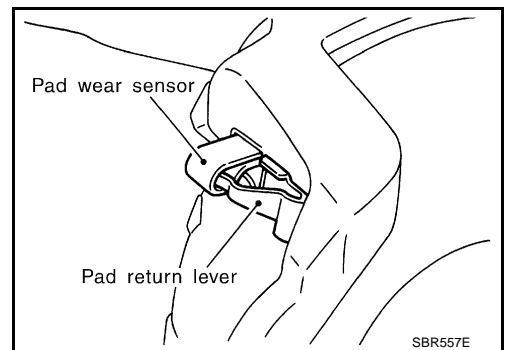

FRONT DISC BRAKE

4. Install lower sliding pin bolt, and tighten it to the specified torque.
5. Check brake for drag.

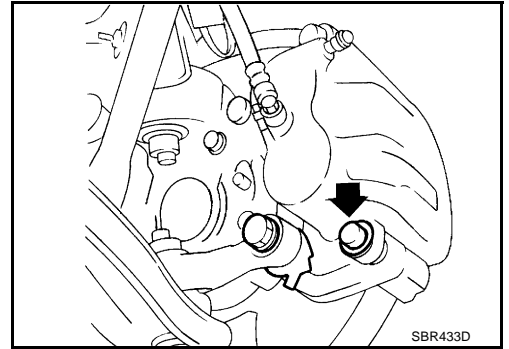

Caliper Removal and Installation REMOVAL

1. Connect a vinyl tube to bleed valve.
2. Drain brake fluid gradually from bleed valve while depressing brake pedal.
3. Remove union bolts, and then remove brake hose from caliper assembly.
4. Remove mounting bolts from torque member, and remove caliper assembly from vehicle with power tool.
5. Remove disc rotor.

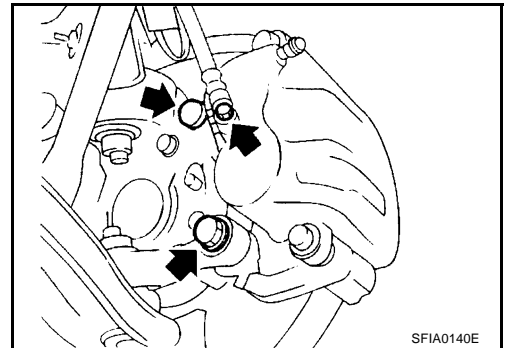

INSTALLATION

1. Install disc rotor.
2. Install caliper assembly to vehicle, and tighten mounting bolts to the specified torque.

CAUTION:

Before installing torque member to vehicle, wipe oil and grease on washer seats on knuckle spindle and mounting surface of torque member.

3. Install brake hose by aligning with protrusions on caliper assembly, and tighten union bolts to the specified torque.

CAUTION:

- Do not reuse copper washer for union bolts.
- Assemble brake hose securely to protrusions on caliper assembly.

4. After installing caliper assembly, refill with new brake fluid and bleed air.

Caliper Disassembly and Assembly DISASSEMBLY

1. Remove caliper assembly from vehicle.
2. Remove sliding pin bolts from cylinder body, and remove pad, shim, shim cover and pad retainer from torque member.

CAUTION:

When removing pad retainer from torque member, lift the pad retainer in the direction shown by arrow (shown in the figure) so as not to deform it.

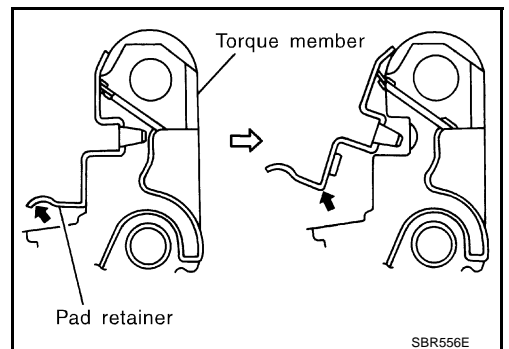

FRONT DISC BRAKE

3. Remove sliding pins and sliding pin boots from torque member.
4. Place a wooden block as shown at left, and blow air from union bolt mounting hole to remove pistons and piston boots.

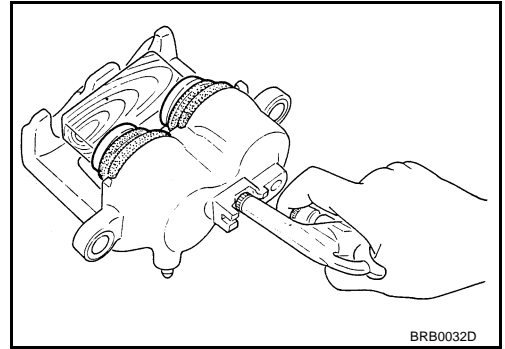

5. Using a flat-bladed screwdriver, remove piston seals from cylinder body.

CAUTION:
Be careful not to damage inner wall of cylinder.

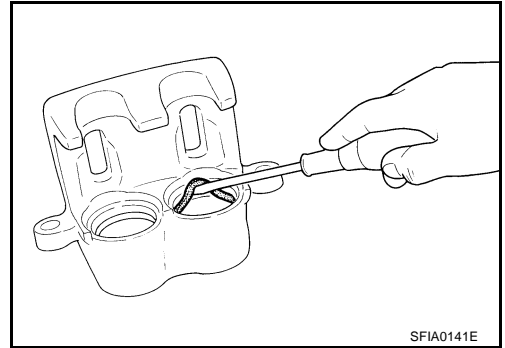

CALIPER INSPECTION

Cylinder Body

CAUTION:

Use new brake fluid to clean. Never use mineral oils such as gasoline or kerosene.

- Check inner wall of cylinder for corrosion, wear, and damage. If a failure is detected, replace cylinder body.
- Minor flaws caused by corrosion or a foreign material can be removed by polishing surface with a fine sandpaper. Replace cylinder body, if necessary.

Torque Member

Check for wear, cracks, and damage. If a malfunction is detected, replace applicable part.

Piston

CAUTION:

The piston sliding surface is plated. Do not polish with sandpaper.

Check piston surface for corrosion, wear, and damage. If a malfunction is detected, replace applicable part.

Sliding Pin, Pin Bolt, and Pin Boot

Check sliding pin and sliding pin boot for wear, damage, and cracks. If a malfunction is detected, replace applicable part.

DISC ROTOR INSPECTION

Visual Inspection

Check surface of disc rotor for uneven wear, cracks, and serious damage. If a malfunction is detected, replace applicable part.

Run Out Inspection

1. Using wheel nuts, fix disc rotor to wheels hub. (2 or more positions)

A
B
C
D
E
BR
G
H
I
J
K
L
M

FRONT DISC BRAKE

- Using a dial indicator, check run out.

Measurement point : At a point 10 mm (0.394 in) from outer edge of disc.
Maximum run out : 0.05 mm (0.002 in) or less

CAUTION:

Before measuring, make sure that axle end play is 0 mm.

- If run out is outside limit, find the minimum run out point by shifting the mounting positions of disc rotor and wheel hub by one hole.

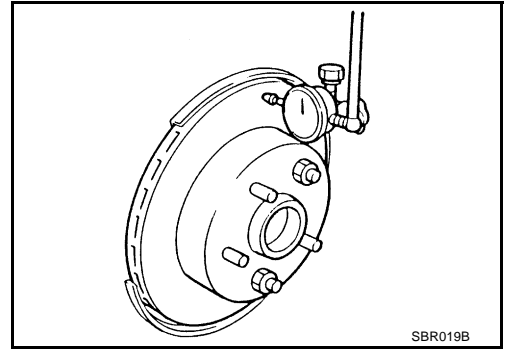

Thickness Inspection

- Using a micrometer, check thickness of disc rotor. If thickness is outside standard, replace disc rotor.

Standard thickness : 28.0 mm (1.10 in)
Wear limit : 26.0 mm (1.02 in)
Maximum uneven wear (measured at 8 positions) : 0.015 mm (0.0006 in) or less

- If run out is still out of specification, turn rotor with on-car brake lathe ("MAD, DL-8700", "AMMCO 700 and 705" or equivalent).

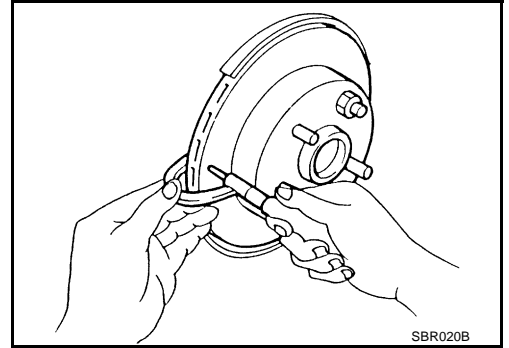

ASSEMBLY

CAUTION:

When assembling, do not use NISSAN rubber grease (KRE00 00010, AKRE00 00010 01).

- Apply rubber lubricant to piston seals, and install them to cylinder body.

CAUTION:

Do not reuse piston seals.

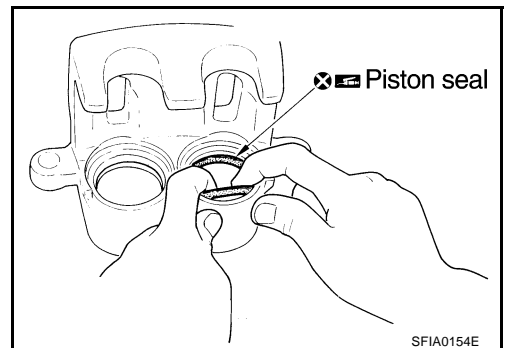

- Apply brake fluid to piston boots. Cover the piston end with piston boot, and install cylinder-side lip on piston boot properly into groove on cylinder body.

CAUTION:

Do not reuse piston boot.

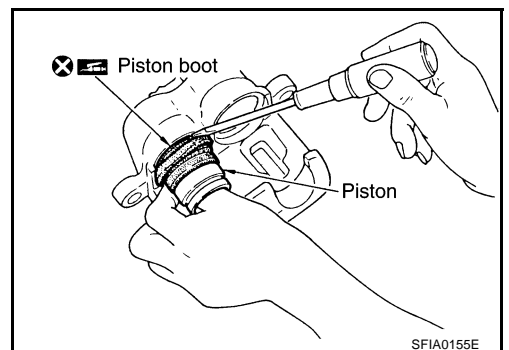

FRONT DISC BRAKE

3. Apply brake fluid to piston, and press piston into cylinder body by hand to assemble piston-side lip on piston boot properly into groove on piston.

CAUTION:

Press piston evenly and change the pressing point to prevent inner wall of cylinder from being rubbed.

4. Install sliding pins and sliding pin boots to torque member.

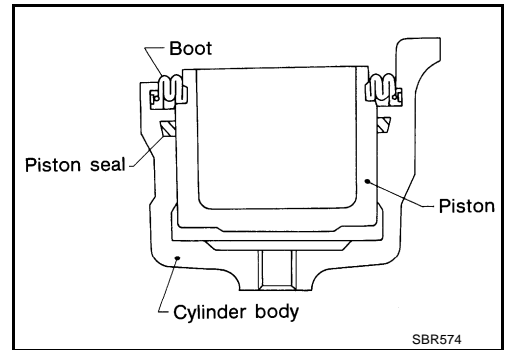

5. Install torque member to knuckle spindle and tighten mounting bolts to the specified torque.

CAUTION:

Before installing torque member to vehicle, wipe oil and grease on washer seats on knuckle spindle and mounting surface of torque member.

6. Install pad retainers to torque member.
7. After assembling shims and shim covers to pad, install it to torque member.

CAUTION:

The inner pad and outer pad have pad-return mechanism on upper side of pad retainer. When installing pad, be sure to install pad return lever to pad wear sensor securely shown to left.

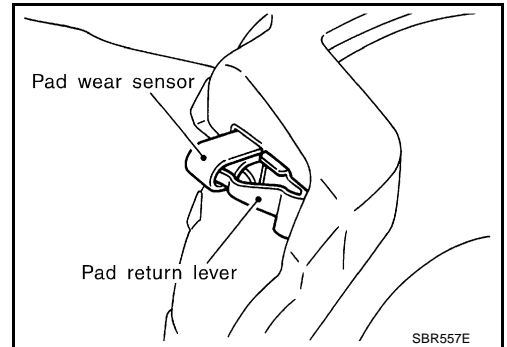

8. Install cylinder body, and tighten sliding pin bolt to the specified torque.
9. Install brake hose to cylinder body and tighten union bolts to the specified torque.

CAUTION:

- Assemble brake hose securely to protrusions on cylinder body.
- Do not reuse copper washer for union bolts.

10. After installing caliper assembly, refill with new brake fluid and bleed air.

Brake Burnishing Procedure

EFS000NV

Burnish brake contact surfaces according to following procedure after refinishing or replacing drums or rotors, after replacing pads or linings, or if a soft pedal occurs at very low mileage.

CAUTION:

Only perform this procedure under safe road and traffic conditions. Use extreme caution.

1. Drive the vehicle on a straight smooth road at 50 km/h (31 MPH).
2. Use medium brake pedal/foot effort to bring the vehicle to a complete stop from 50 km/h (31 MPH). Adjust brake pedal/foot pressure such that vehicle stopping time equals 3 to 5 seconds.
3. To cool the brake system, drive the vehicle at 50 km/h (31 MPH) for 1 minute without stopping.
4. Repeat steps 1 to 3, 10 times or more to complete the burnishing procedure.

A
B
C
D
E
BR
G
H
I
J
K
L
M

REAR DISC BRAKE

PFP:44000

EFS000NN

REAR DISC BRAKE

Component

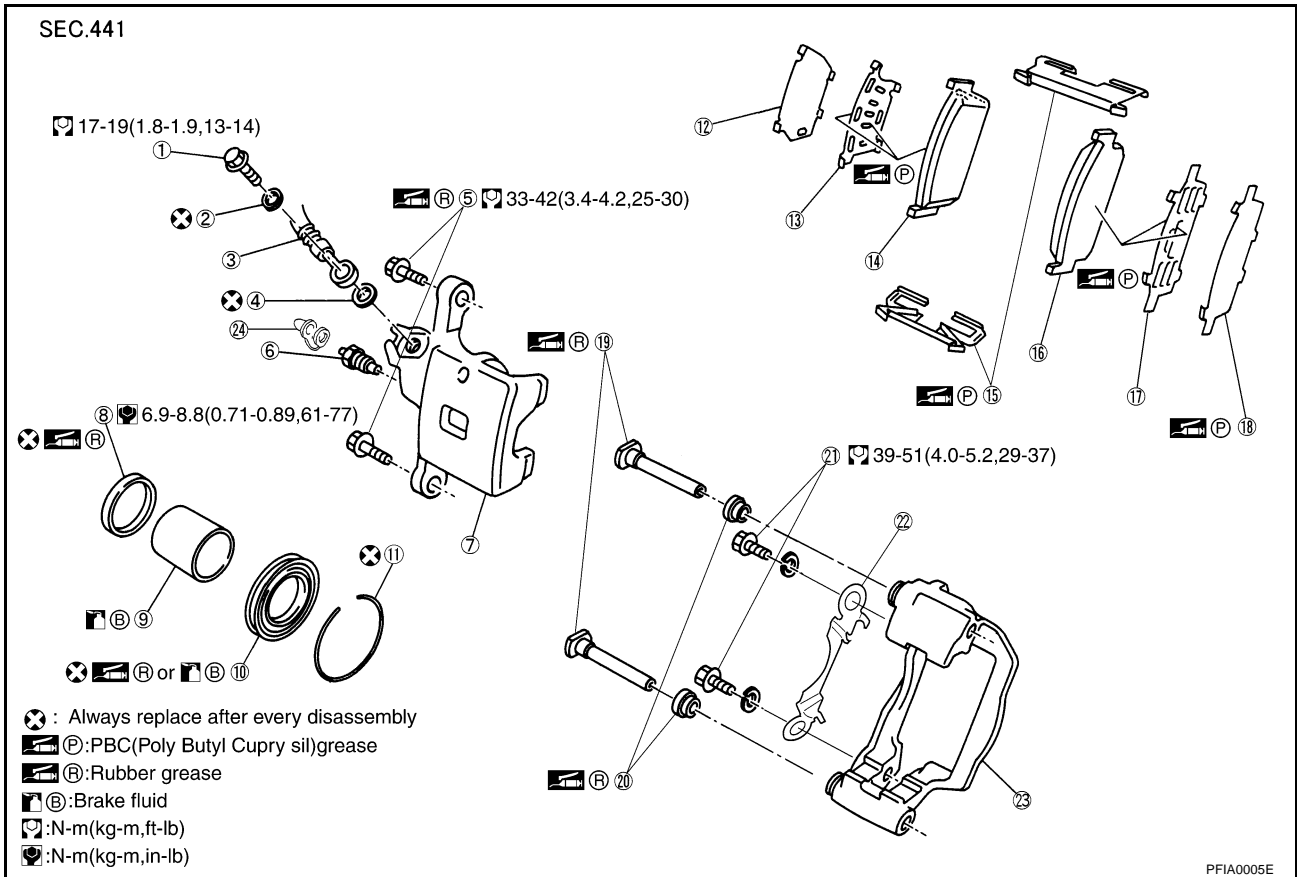

- | | | |
|--|----------------------|----------------------------------|
| 1. Union bolt | 2. Copper washer | 3. Brake hose |
| 4. Copper washer | 5. Sliding pin bolt | 6. bleed valve |
| 7. Cylinder body | 8. Piston seal | 9. Piston |
| 10. Piston boot | 11. Retaining ring | 12. Inner shim cover |
| 13. Inner shim | 14. Inner brake pad | 15. Pad retainer |
| 16. Outer brake pad | 17. Outer shim | 18. Outer shim cover |
| 19. Sliding pin | 20. Sliding pin boot | 21. Torque member mounting bolts |
| 22. Decrement shim
(Not inserted in some vehicles.) | 23. Torque member | 24. Cap |

CAUTION:

- Clean dust on caliper and brake pad with a vacuum dust collector. Do not blow with compressed air.
- While removing cylinder body, never depress brake pedal because piston will pop out.
- It is not necessary to remove mounting bolts on torque member and brake hose except for disassembly or replacement of caliper assembly. In this case, hang cylinder body with a wire so that brake hose is not under tension.
- Do not damage piston boot.
- Always replace shims and shim covers as a set when replacing brake pads.
- Keep brake fluid clean of rotor.

REAR DISC BRAKE

Inspection

PAD THICKNESS

EFS000NO

- Remove wheel with vehicle lifted to check pad thickness from check hole on cylinder body. If necessary, use a scale to check.

Rear brake pad

Standard thickness : 9.8 mm (0.386 in)

Repair limit thickness : 2.0 mm (0.079 in)

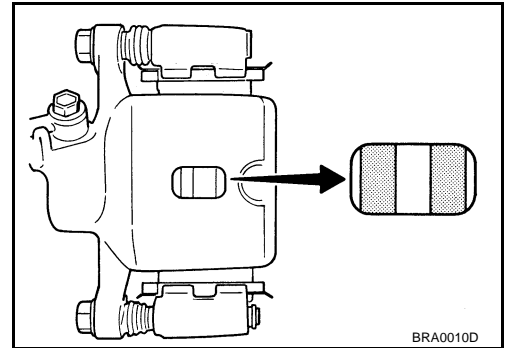

Pad Replacement REMOVAL

EFS000NP

WARNING:

Clean brake pads with a vacuum dust collector to minimize the hazard of airborne particles or other materials.

CAUTION:

- While cylinder body is open, do not depress brake pedal, otherwise piston will pop out.
 - Be careful not to damage piston boot or get oil on rotor, Always replace shims when replacing pads.
 - If shims are rusted or show peeling of rubber coat, replace them with new shims.
 - It is not necessary to remove connecting bolt except for disassembly or replacement of caliper assembly. In this case, suspend cylinder body with wire so as not to stretch brake hose.
 - Carefully monitor brake fluid level because brake fluid will return to reservoir when pushing back piston.
 - Burnish brake contact surfaces after refinishing or replacing drums or rotor, after replacing pads or linings, or if a soft pedal occurs at very low mileage. Refer to [BR-29, "Brake Burnishing Procedure"](#).
1. Remove master cylinder reservoir cap.
 2. Remove lower sliding pin bolt.

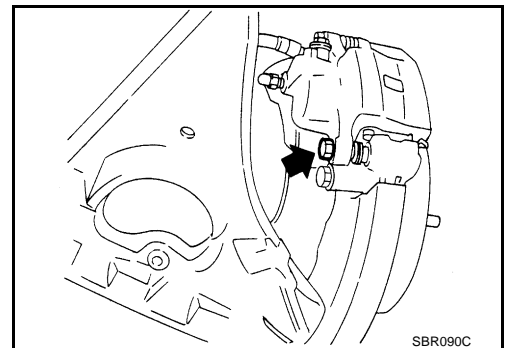

REAR DISC BRAKE

3. Hang the cylinder body with a wire, and remove pads, pad retainers, shims from torque member.

CAUTION:

- Do not damage piston boot.
- Keep brake fluid clean of rotor.

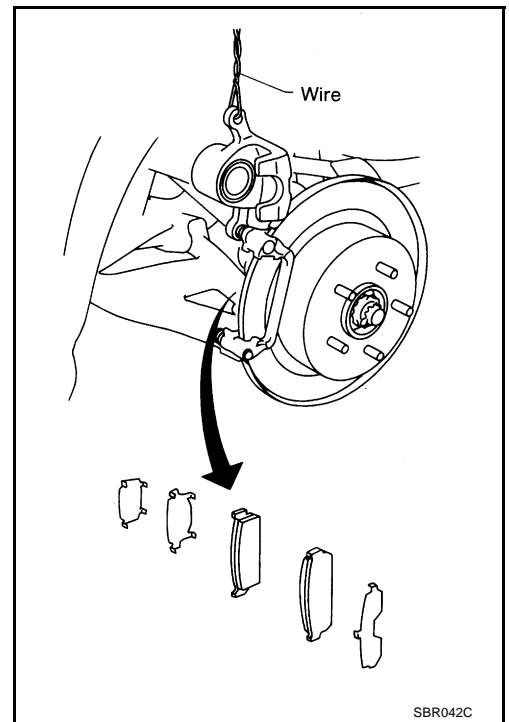

INSTALLATION

1. Apply disc brake grease to back of pad and both sides of shim, and install inner shim and shim cover to inner pad, and outer shim and outer shim cover to pad.
2. Apply disc brake grease to pad contact surface on pad retainer, and install pad retainers and pads to torque member.
3. Install cylinder body to torque member.

CAUTION:

When replacing pads with new ones, press in piston until pads can be installed. In this case, carefully monitor brake fluid level in reservoir tank because brake fluid will return to reservoir tank of master cylinder.

4. Insert lower sliding pin bolt to tighten to specified torque.
5. Check brake for drag.

Caliper Removal and Installation

REMOVAL

1. Connect a vinyl tube to bleed valve.
2. Drain brake fluid gradually from bleed valve while depressing brake pedal.
3. Remove union bolts, and then remove brake hose from caliper assembly.
4. Remove mounting bolts from torque member, and remove caliper assembly from vehicle with power tool.
5. Remove disc rotor.

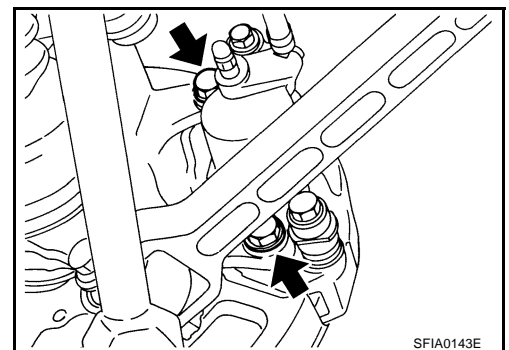

INSTALLATION

1. Install disc rotor.
2. Install caliper assembly to vehicle, and tighten mounting bolts to specified torque.

CAUTION:

Before installing caliper assembly to vehicle, wipe oil and grease on washer seats on axle assembly and mounting surface of caliper assembly.

3. Install brake hose to caliper assembly and tighten union bolts to the specified torque.

REAR DISC BRAKE

CAUTION:

- Do not reuse copper washer for union bolts.
- Assemble brake hose securely to protrusion on caliper assembly.

4. After installing caliper assembly, refill with new brake fluid and bleed air.

Caliper Disassembly and Assembly

DISASSEMBLY

1. Remove caliper assembly from vehicle.
2. Remove sliding pins. Then remove pads, shims, and shim covers from caliper assembly, and remove pad retainers from cylinder body.
3. Remove sliding pin boot from torque member.
4. Using a flat-bladed screwdriver as shown in figure, remove retaining ring from cylinder body.

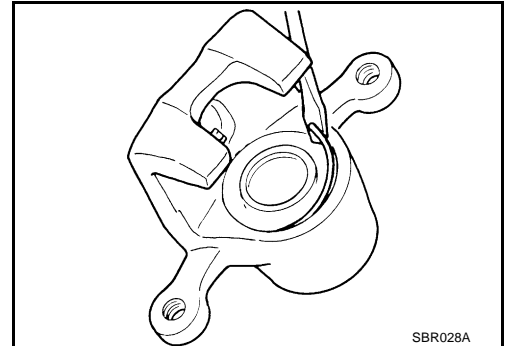

5. Place a wooden block as shown in figure, and blow air from union bolt mounting hole to remove pistons and piston boots.

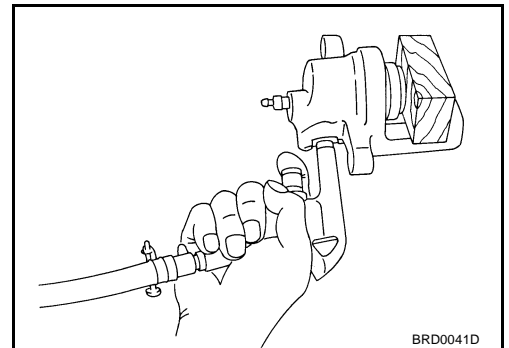

6. Using a flat-bladed screwdriver, remove piston seals from cylinder body.

CAUTION:

Be careful not to damage inner wall of cylinder.

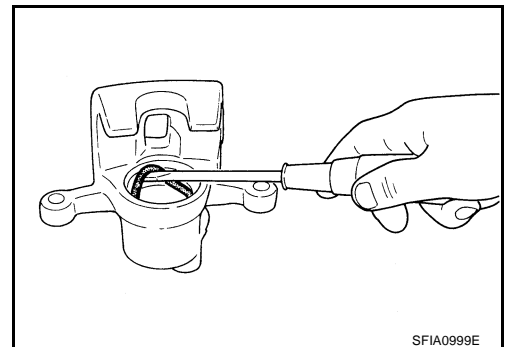

INSPECTION AFTER DISASSEMBLY

Cylinder Body

CAUTION:

Use new brake fluid to clean. Never use mineral oils such as gasoline or kerosene.

- Check inner wall of cylinder for corrosion, wear, and damage. If a failure is detected, replace cylinder body.
- Minor flaws caused by corrosion or foreign material can be removed by polishing the surface with a fine sandpaper. Replace cylinder body, if necessary.

Torque Member

Check for wear, cracks, and damage. If a malfunction is detected, replace applicable part.

Piston

CAUTION:

The piston sliding surface is plated. Do not polish with sandpaper.

Check piston surface for corrosion, wear, and damage. If a malfunction is detected, replace applicable part.

REAR DISC BRAKE

Sliding Pin, Pin Bolt and Pin Boot

Check sliding pin and sliding pin boot for wear, damage, and cracks. If a malfunction is detected, replace applicable part.

DISC ROTOR INSPECTION

Visual Inspection

Check surface of disc rotor for uneven wear, cracks, and serious damage. If a malfunction is detected, replace applicable part.

Run Out Inspection

1. Using wheel nuts, fix the disc rotor to wheels hub. (2 or more positions)
2. Using a dial indicator, check run out.

Measurement point : At a point 10 mm (0.39 in) from outer edge of disc.

Maximum run out : 0.07 mm (0.0028 in) or less

CAUTION:

Before measuring, make sure that axle end play is 0 mm.

3. If run out is outside limit, find minimum run out point by shifting mounting positions of disc rotor and wheel hub by one hole.

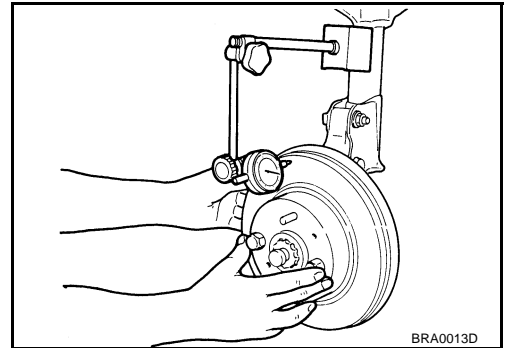

Thickness Inspection

Using a micrometer, check thickness of disc rotor. If thickness is outside standard, replace disc rotor.

Standard thickness : 16.0 mm (0.63 in)

Wear limit : 14.0 mm (0.55 in)

Maximum uneven wear (measured at 8 positions) ; 0.015 mm (0.0006 in) or less

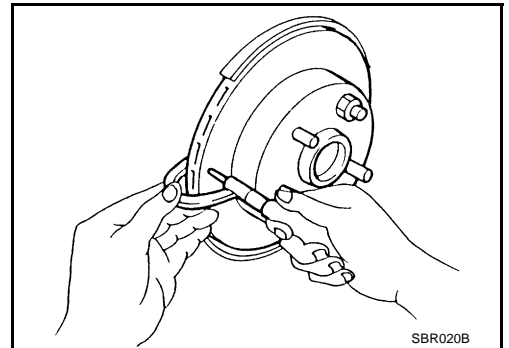

ASSEMBLY

1. Apply brake fluid to piston seals and install them to cylinder body.

CAUTION:

Do not reuse piston seals.

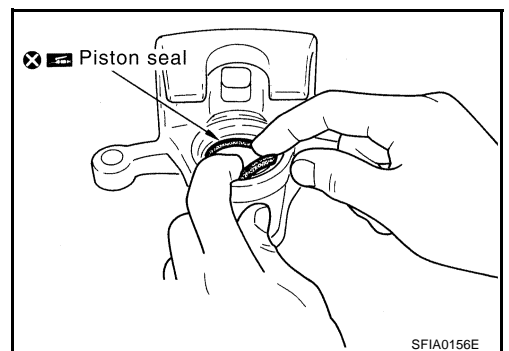

2. Apply brake fluid to piston boots. Cover the piston end with piston boot, and install cylinder-side lip on piston boots properly into groove on cylinder body.

CAUTION:

Do not reuse piston boot.

3. Press piston into cylinder body by hand to assemble piston-side lip on piston boot properly into groove on piston.

CAUTION:

Press the piston evenly and change the pressing point to prevent inner wall of cylinder from being rubbed.

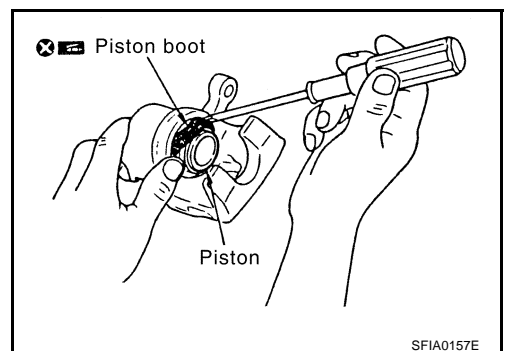

REAR DISC BRAKE

- Fix the piston boot with retaining ring.

CAUTION:

- Make sure that boot is securely engaged in groove on cylinder body.
- Do not reuse retaining ring.

- Install sliding pins and sliding pin boots to torque member.
- Install torque member to axle assembly, and tighten mounting bolts to the specified torque.

CAUTION:

Before installing torque member to axle assembly, wipe oil and grease on washer seats on axle assembly and mounting surface of torque member.

- Install pad retainers to torque member.
- After assembling shims and shim covers to pads, assemble it to torque member.
- Install cylinder body, and tighten sliding pin bolts to the specified torque.
- Install brake hose to cylinder body and tighten union bolts to the specified torque.

CAUTION:

- Assemble brake hose securely to protrusions on cylinder body.
- Do not reuse copper washer on union bolt.

- After installing caliper assembly, refill new brake fluid and bleed air.

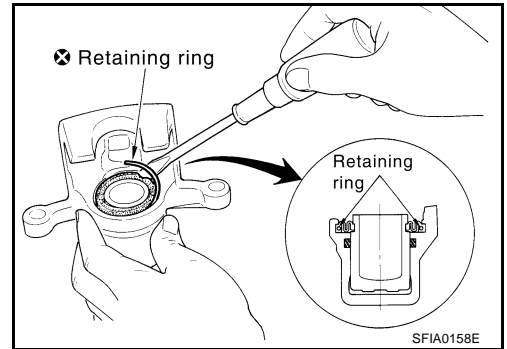

A

B

C

D

E

BR

G

H

I

J

K

L

M

SERVICE DATA AND SPECIFICATIONS (SDS)

SERVICE DATA AND SPECIFICATIONS (SDS)

PFP:00030

General Specifications

EFS00009

Unit: mm (in)

Front brake	Brake model		CLZ31VA
	Cylinder bore diameter		42.86 (1.687) × 2
	Pad Length × width × thickness		127.0 × 56.0 × 10.0 (5.00 × 2.20 × 0.394)
	Rotor outer diameter × thickness		290 × 28 (11.42 × 1.10)
Rear brake	Brake model		AD14VD
	Cylinder bore diameter		43.86 (1.727)
	Pad Length × width × thickness		97.4 × 33.9 × 9.8 (3.835 × 1.335 × 0.386)
	Rotor outer diameter × thickness		292 × 16 (11.50 × 0.63)
Master cylinder	Cylinder bore diameter		25.4 (1 in)
Control valve	Valve model		Electric brake force distribution
Brake booster	Booster model		M215T
	Diaphragm diameter	Primary	230 (9.06)
		Secondary	205 (8.07)
Recommended brake fluid			DOT 3

Brake Pedal

EFS000GJ

Free play (at pedal top surface)	3 - 11 mm (0.12 - 0.43 in)
Brake pedal height (from dash panel top surface)	192.4 - 202.4 mm (7.57 - 7.97 in)
Depressed pedal height under force of 490 N (50 kg, 110 lb) (from dash panel top surface)	90 mm (3.54 in) or more
Clearance between stopper rubber and threaded end of stop lamp switch/ASCD cancel switch	0.74 - 1.96 mm (0.0291 - 0.0772 in)

Check Valve

EFS000GK

Vacuum leakage [at vacuum of - 66.7 kPa (- 500 mmHg, - 19.69 inHg)]	Within 1.3 kPa (10 mmHg, 0.39 inHg) of Vacuum for 15 seconds
--	--

Brake Booster Vacuum type

EFS000GL

Vacuum leakage [at vacuum of - 66.7 kPa (- 500 mmHg, - 19.69 inHg)]	Within 3.3 kPa (25 mmHg, 0.98 inHg) of vacuum for 15 seconds
Input rod installation standard dimension	125 mm (4.92 in)

Front Disc Brake

EFS000GM

Brake type		CLZ31VA
Brake pad	Standard thickness (new)	10.0 mm (0.394 in)
	Repair limit thickness	2.0 mm (0.079 in)
Disc rotor	Standard thickness (new)	28.0 mm (1.10 in)
	Repair limit thickness	26.0 mm (1.02 in)
	Maximum run out	0.05 mm (0.002 in) or less

Rear Disc Brake

EFS000GN

Brake type		AD14VD
Brake pad	Standard thickness (new)	9.8 mm (0.386 in)
	Repair limit thickness	2.0 mm (0.079 in)

SERVICE DATA AND SPECIFICATIONS (SDS)

Brake type		AD14VD
Disc rotor	Standard thickness (new)	16.0 mm (0.63 in)
	Repair limit thickness	14.0 mm (0.55 in)
	Maximum run out	0.07 mm (0.0028 in) or less

A

B

C

D

E

BR

G

H

I

J

K

L

M

SERVICE DATA AND SPECIFICATIONS (SDS)
