

A  
B  
C  
D  
E

# SECTION **PB**

## PARKING BRAKE SYSTEM

### CONTENTS

<p><b>PRECAUTIONS</b> ..... 2</p> <p style="padding-left: 20px;">Precautions for Supplemental Restraint System (SRS) "AIR BAG" and "SEAT BELT PRE-TENSIONER" ..... 2</p> <p><b>PARKING BRAKE SYSTEM</b> ..... 3</p> <p style="padding-left: 20px;">On-Vehicle Service ..... 3</p> <p style="padding-left: 40px;">INSPECTION ..... 3</p> <p style="padding-left: 40px;">ADJUSTMENT ..... 3</p> <p><b>PARKING BRAKE CONTROL</b> ..... 4</p> <p style="padding-left: 20px;">Components ..... 4</p> <p style="padding-left: 20px;">Removal and Installation ..... 4</p> <p style="padding-left: 40px;">REMOVAL ..... 4</p>	<p style="padding-left: 40px;">INSTALLATION ..... 5</p> <p style="padding-left: 60px;">Inspection ..... 5</p> <p><b>PARKING BRAKE SHOE</b> ..... 6</p> <p style="padding-left: 20px;">Components ..... 6</p> <p style="padding-left: 20px;">Removal and Installation ..... 6</p> <p style="padding-left: 40px;">REMOVAL ..... 6</p> <p style="padding-left: 40px;">INSTALLATION ..... 7</p> <p style="padding-left: 40px;">BREAKING IN DRUM AND LINING ..... 8</p> <p style="padding-left: 60px;">Inspection ..... 8</p> <p><b>SERVICE DATA AND SPECIFICATIONS (SDS)</b> ..... 9</p> <p style="padding-left: 20px;">Parking Drum Brake ..... 9</p> <p style="padding-left: 20px;">Parking Brake Control ..... 9</p>
--	---

PB  
G  
H  
I  
J  
K  
L  
M

# PRECAUTIONS

---

## PRECAUTIONS

PFP:00001

### Precautions for Supplemental Restraint System (SRS) “AIR BAG” and “SEAT BELT PRE-TENSIONER”

EFS00282

The Supplemental Restraint System such as “AIR BAG” and “SEAT BELT PRE-TENSIONER”, used along with a front seat belt, helps to reduce the risk or severity of injury to the driver and front passenger for certain types of collision. This system includes seat belt switch inputs and dual stage front air bag modules. The SRS system uses the seat belt switches to determine the front air bag deployment, and may only deploy one front air bag, depending on the severity of a collision and whether the front occupants are belted or unbelted. Information necessary to service the system safely is included in the SRS and SB section of this Service Manual.

#### **WARNING:**

- To avoid rendering the SRS inoperative, which could increase the risk of personal injury or death in the event of a collision which would result in air bag inflation, all maintenance must be performed by an authorized NISSAN/INFINITI dealer.
- Improper maintenance, including incorrect removal and installation of the SRS, can lead to personal injury caused by unintentional activation of the system. For removal of Spiral Cable and Air Bag Module, see the SRS section.
- Do not use electrical test equipment on any circuit related to the SRS unless instructed to in this Service Manual. SRS wiring harnesses can be identified by yellow and/or orange harnesses or harness connectors.

# PARKING BRAKE SYSTEM

## PARKING BRAKE SYSTEM

PFP:36010

### On-Vehicle Service INSPECTION

EPS000GP

- While depressing parking brake pedal to specified amount of force, check that pedal stroke is within the range of specified stroke amount.

**Number of notches : 4 - 5**

- Check that warning lamp comes on when parking brake pedal is depressed with in one notch.

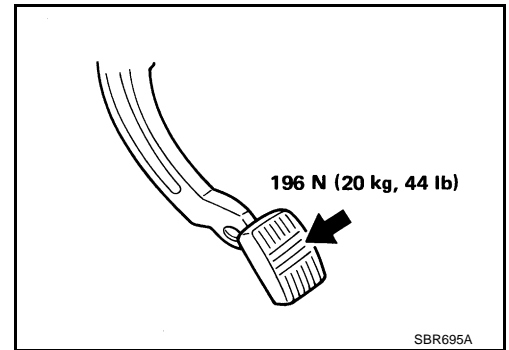

### ADJUSTMENT

1. Insert a deep-well socket wrench to rotate self-locking nut to loosen cable sufficiently. Then, after returning pedal completely, adjust the clearance of rear shoes.
2. Remove road wheels.
3. Using a wheel nut, fix the disc to hub preventing it from tilting.

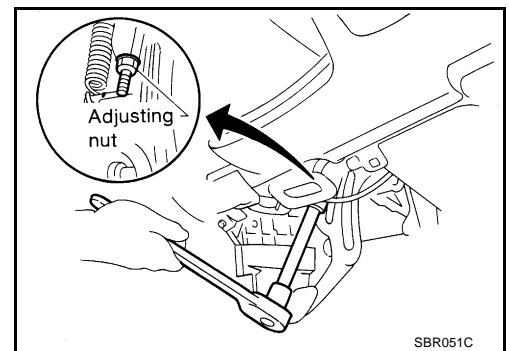

4. Remove adjuster hole plug installed on disc. Using a flat-bladed-screwdriver, turn disc to clock wise as shown in figure until disc is locked. After locking, turn adjuster to opposite direction by 5 or 6 notches.
5. Rotate disc to make sure that there is no drag. Then install adjuster hole plug.
6. After adjusting the clearance of rear shoes, with no drag on rear brake, adjust cable as follows:
  - a. Operate pedal 10 or more times with the force of 294 N (30 kg, 66 lb).
  - b. Depress pedal until a deep-well socket can be inserted. Insert deep-well socket, and rotate self-locking nut to adjust pedal stroke.

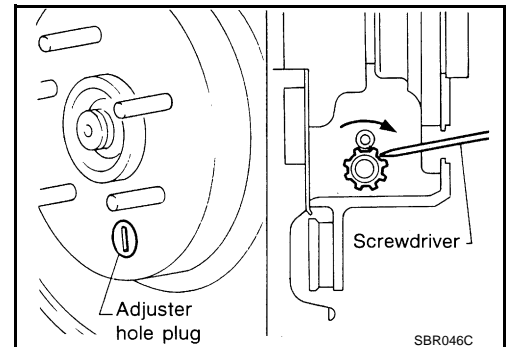

### CAUTION:

**Do not reuse self-locking nut after removing it.**

- c. After operating pedal 3 to 4 times with the force of 196 N (20 kg, 44 lb), make sure that pedal stroke is within specified value.
- d. With pedal completely returned, make sure that there is no drag on rear brake.

# PARKING BRAKE CONTROL

PFP:36010

## PARKING BRAKE CONTROL

### Components

EFS00002

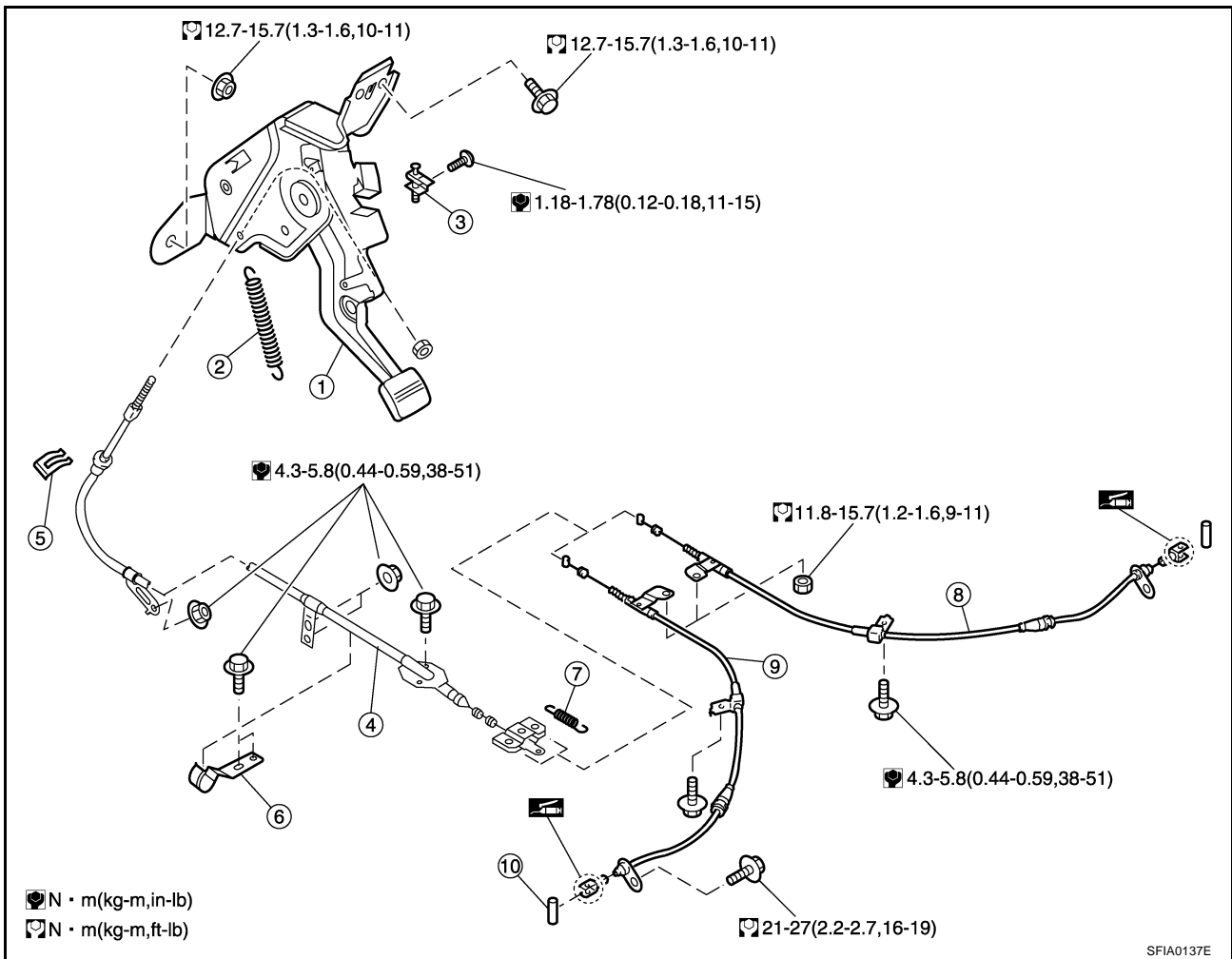

- |                                 |                  |                        |
|---------------------------------|------------------|------------------------|
| 1. Parking brake pedal Assembly | 2. Return spring | 3. Warning lamp switch |
| 4. Front cable                  | 5. Lock plate    | 6. Clamp               |
| 7. Return spring                | 8. RH rear cable | 9. LH rear cable       |
| 10. Stopper pin                 |                  |                        |

## Removal and Installation

### REMOVAL

EFS00003

1. Remove console. Refer to [IP-10, "INSTRUMENT PANEL ASSEMBLY"](#).
2. Remove self-locking nut from device assembly.
3. Remove exhaust center tube. Refer to [EX-3, "Removal and Installation"](#).
4. Remove propeller shaft. Refer to [PR-3, "Removal and Installation"](#).
5. Remove rear disc caliper and disc rotor.
6. Remove parking brake shoe, and remove rear cable from toggle lever.
7. Remove cable mounting nuts.
8. Remove right and left rear cable from vehicle.
9. Remove air bag sensor unit with sensor mount bracket. Refer to [SRS-45, "Removal and Installation"](#).
10. Remove front cable mounting nuts and bolts, and remove front cable from vehicle.
11. Remove mounting bolts of release cable and device assembly, and remove device assembly from vehicle.

# PARKING BRAKE CONTROL

---

## INSTALLATION

1. Install in the reverse order of removal. Tighten mounting bolts and nuts to the specified torque.

**CAUTION:**

**Do not reuse self-locking nut of parking cable.**

2. Adjust clearance of parking brake shoes.

## Inspection

EFS00004

- Check device assembly for bend, damage, and cracks. Replace if necessary.
- Check cable and equalizer for wear and damage.
- Check warning lamp switch. Replace if necessary.
- Check each part for deformation, or damage by contact with other parts. Replace if necessary.

A  
B  
C  
D  
E  
PB  
G  
H  
I  
J  
K  
L  
M

# PARKING BRAKE SHOE

PFP:44060

## PARKING BRAKE SHOE

### Components

EFS00005

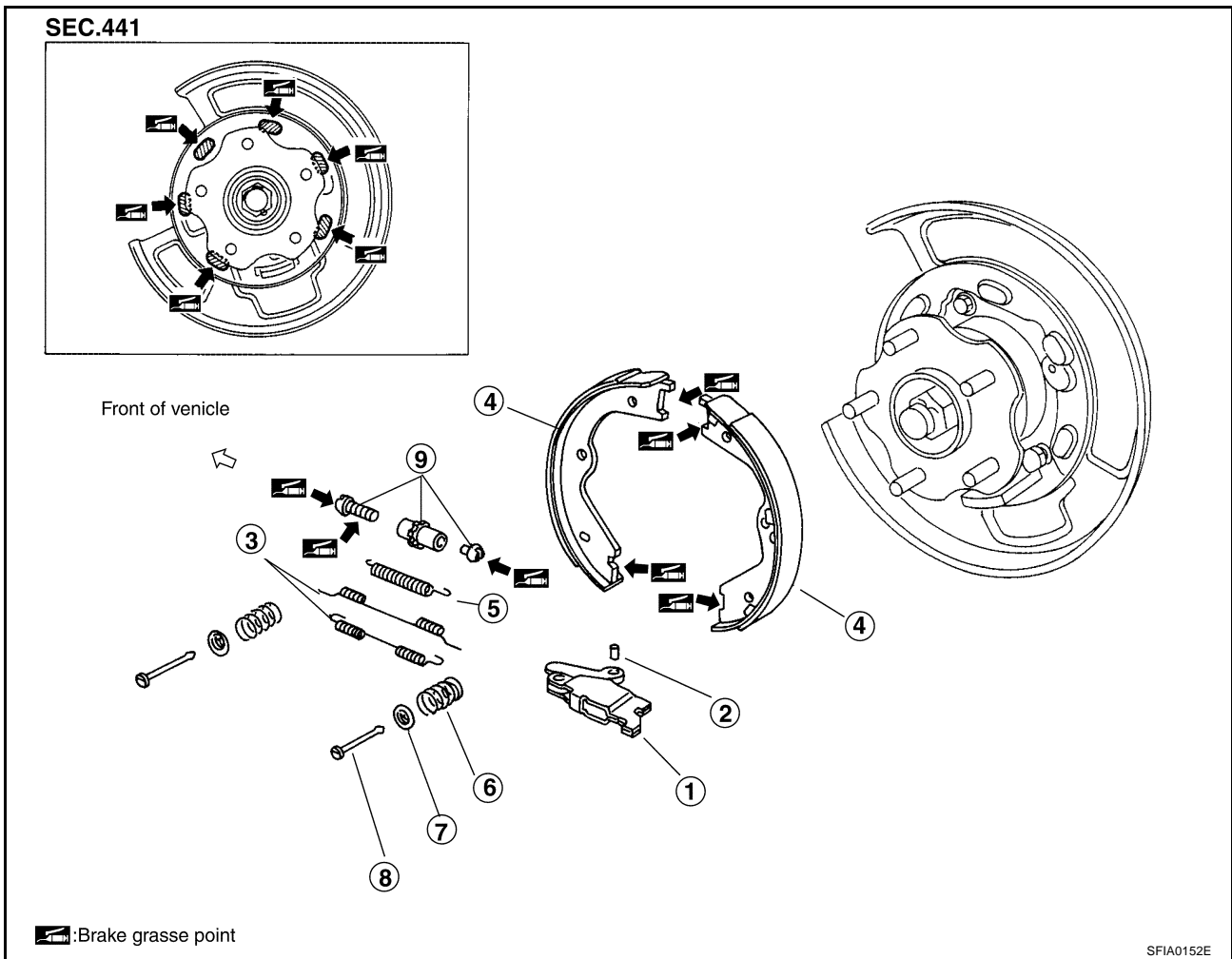

- |                 |                    |                       |
|-----------------|--------------------|-----------------------|
| 1. Toggle lever | 2. Stopper pin     | 3. Return spring      |
| 4. Shoe         | 5. Adjuster spring | 6. Anti-rattle spring |
| 7. Retainer     | 8. Anti-rattle pin | 9. Adjuster assembly  |

## Removal and Installation

### REMOVAL

EFS00006

#### WARNING:

Clean brakes with a vacuum dust collector to minimize the hazard of airborne particles or other materials.

#### CAUTION:

- Remove wheel, and remove disc rotor with parking pedal completely returned.
  - If disc rotor cannot be removed, remove as follows:
1. Fix the disc rotor with wheel nut, and remove adjuster hole plug. Using a flat-bladed screwdriver, rotate star wheel on the adjuster assembly in the direction B to loosen, and retract brake shoes.
  2. Remove plug.
  3. Insert flat-bladed screwdriver through plug. Turn adjuster to make clearance between brake shoe and drum.

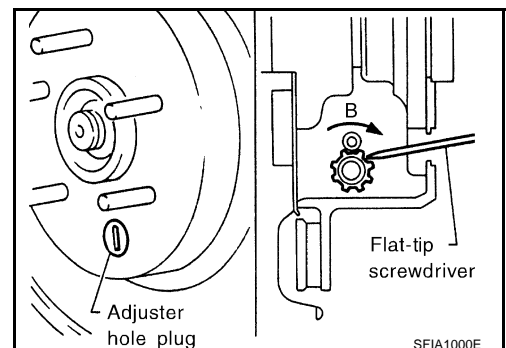

# PARKING BRAKE SHOE

## INSTALLATION

Install all parts in the reverse order of while taking care of the following.

- Apply brake grease to contact areas shown in figure.

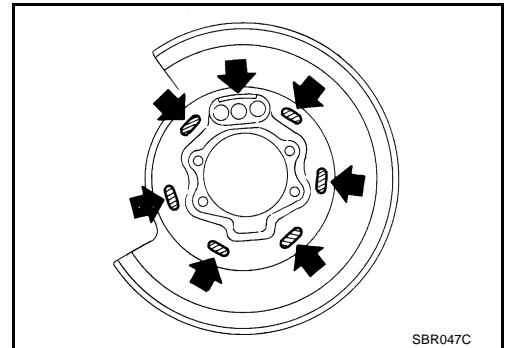

- Assemble return spring A under return spring B as shown at C in figure.

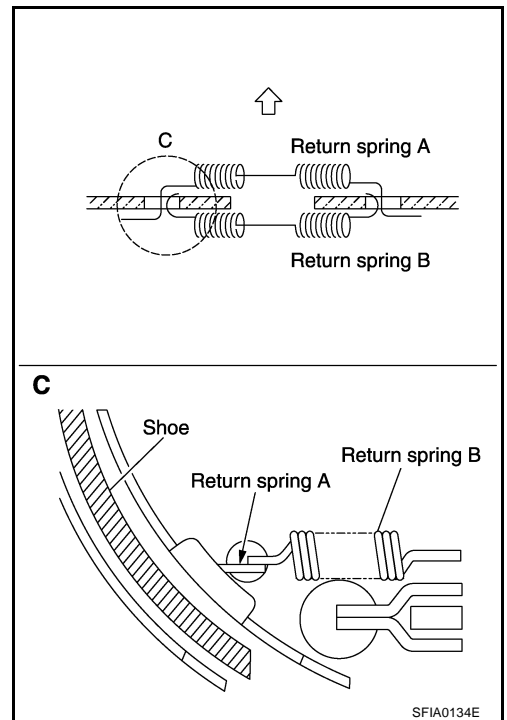

- The orientation of adjuster is different from left to right. Assemble the adjuster so that threaded part is expanded when rotating it to direction shown by arrow. Contract adjuster to assemble. When disassembling adjuster, apply brake grease to thread.
- Adjust parking brake pedal stroke to the specified amount.
- After replacing shoe or disc rotor, or if brake does not function well, carry out break-in operation as follows.

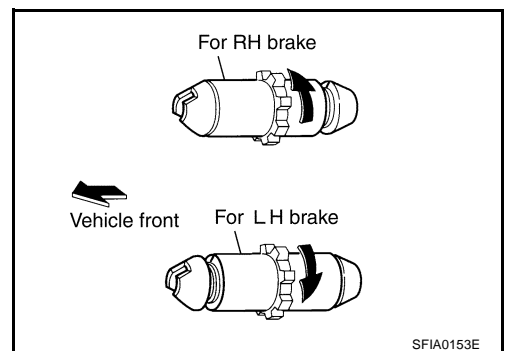

A  
B  
C  
D  
E  
PB  
G  
H  
I  
J  
K  
L  
M

# PARKING BRAKE SHOE

## BREAKING IN DRUM AND LINING

### CAUTION:

Do not carry out break-in procedure excessively, because it may cause the uneven wear or pre-mature wear of lining.

When a new rotor/parking brake shoe is installed, or when braking performance is poor, perform the following break-in procedure.

1. Drive the unloaded vehicle on a safe, level and dry road.
2. Depress parking brake pedal with a force of 147 N (15 kg, 33 lb).
3. While depressing pedal, continue to drive vehicle for-ward 100 m (328 ft) at approximately 35 km/h (22 MPH).
4. Cool down parking brake for approx. Five minutes.
5. After releasing pedal, drive vehicle under the normal conditions for two minutes to cool down parking drum brake.
6. Repeat steps 1 through 5 three times and then repeat only step 5 one more time.
7. After the break-in procedure, check pedal stroke of parking brake. If it is out of the specification, adjust again.

## Inspection

- Visually check lining for malfunction wear, damage, and peeling.
- Using a scale, check thickness of lining.

**Standard lining thickness** : 3.2 mm (0.126 in)

**Lining wear limit (A)** : 1.5 mm (0.059 in)

### CAUTION:

If necessary, remove brake shoe, and check as follows.

- Check shoe sliding surface for malfunction wear and damage.
- Check anchor pin for malfunction wear and corrosion.
- Check return spring for sagging.
- Check adjuster for rough operation.
- Visually check the inside of drum for malfunction wear, damage, and cracks. Using a pair of vernier calipers, check the inside of drum.

**Standard inner diameter** : 172.0 mm (6.77 in)

**Maximum inner diameter** : 173.0 mm (6.81 in)

EFS00007

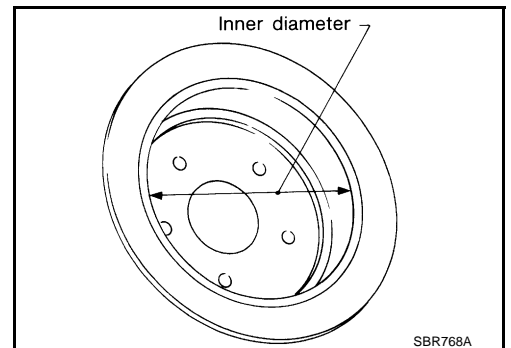
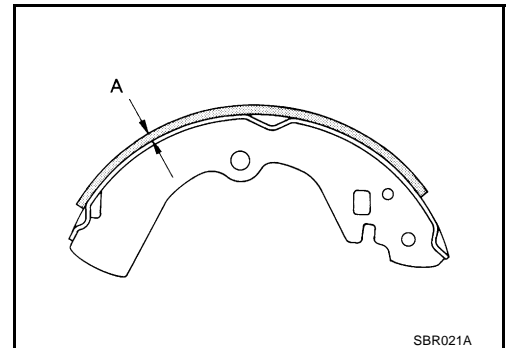



# SERVICE DATA AND SPECIFICATIONS (SDS)

## SERVICE DATA AND SPECIFICATIONS (SDS)

PFP:00030

### Parking Drum Brake

EFS000GU

Type		DS17HF
Brake lining	Standard thickness (new)	3.2 mm (0.126 in)
	Wear limit thickness	1.5 mm (0.059 in)
Drum (disc)	Standard inner diameter (new)	172 mm (6.77 in)
	Wear limit of inner diameter	173 mm (6.81 in)

### Parking Brake Control

EFS000NJ

Control type	Foot lever
Number of notches [under force of 196 N (20 kg, 44lb)]	4 - 5
Number of notches when warning lamp switch comes on	1

A  
B  
C  
D  
E  
G  
H  
I  
J  
K  
L  
M

PB

# SERVICE DATA AND SPECIFICATIONS (SDS)

---