

SECTION **PG**

POWER SUPPLY, GROUND & CIRCUIT ELEMENTS

CONTENTS

POWER SUPPLY ROUTING	2	REAR DOOR HARNESS	45
Schematic	2	Wiring Diagram Codes (Cell Codes)	46
Wiring Diagram — POWER —	3	ELECTRICAL UNITS LOCATION	50
BATTERY POWER SUPPLY—IGNITION SW. IN		Electrical Units Location	50
ANY POSITION	3	ENGINE COMPARTMENT	51
ACCESSORY POWER SUPPLY — IGNITION		PASSENGER COMPARTMENT	52
SW. IN “ACC” OR “ON”	7	LUGGAGE COMPARTMENT	55
IGNITION POWER SUPPLY — IGNITION SW.		HARNESS CONNECTOR	56
IN “ON” AND/OR “START”	9	Description	56
Fuse	13	HARNESS CONNECTOR (TAB-LOCKING	
Fusible Link	13	TYPE)	56
Circuit Breaker	13	HARNESS CONNECTOR (SLIDE-LOCKING	
GROUND	14	TYPE)	57
Ground Distribution	14	JOINT CONNECTOR (J/C)	58
MAIN HARNESS	14	Terminal Arrangement	58
ENGINE ROOM HARNESS	17	ELECTRICAL UNITS	59
ENGINE HARNESS	20	Terminal Arrangement	59
ENGINE CONTROL HARNESS	21	SMJ (SUPER MULTIPLE JUNCTION)	61
BODY HARNESS	23	Terminal Arrangement	61
BODY NO.2 HARNESS	25	STANDARDIZED RELAY	64
HARNESS	28	Description	64
Harness Layout	28	NORMAL OPEN, NORMAL CLOSED AND	
HOW TO READ HARNESS LAYOUT	28	MIXED TYPE RELAYS	64
OUTLINE	29	TYPE OF STANDARDIZED RELAYS	64
MAIN HARNESS	30	FUSE BLOCK - JUNCTION BOX (J/B) NO.1	66
ENGINE ROOM HARNESS	33	Terminal Arrangement	66
ENGINE HARNESS	36	FUSE BLOCK - JUNCTION BOX (J/B) NO.2	67
ENGINE CONTROL HARNESS	37	Terminal Arrangement	67
BODY HARNESS AND REAR CONTROL HAR-		FUSE, FUSIBLE LINK AND RELAY BLOCK (J/B).. 68	
NESS	39	Terminal Arrangement	68
BODY NO. 2 HARNESS	41	FUSE, FUSIBLE LINK AND RELAY BOX	69
ROOM LAMP HARNESS	43	Terminal Arrangement	69
FRONT DOOR HARNESS	44		

POWER SUPPLY ROUTING
Schematic

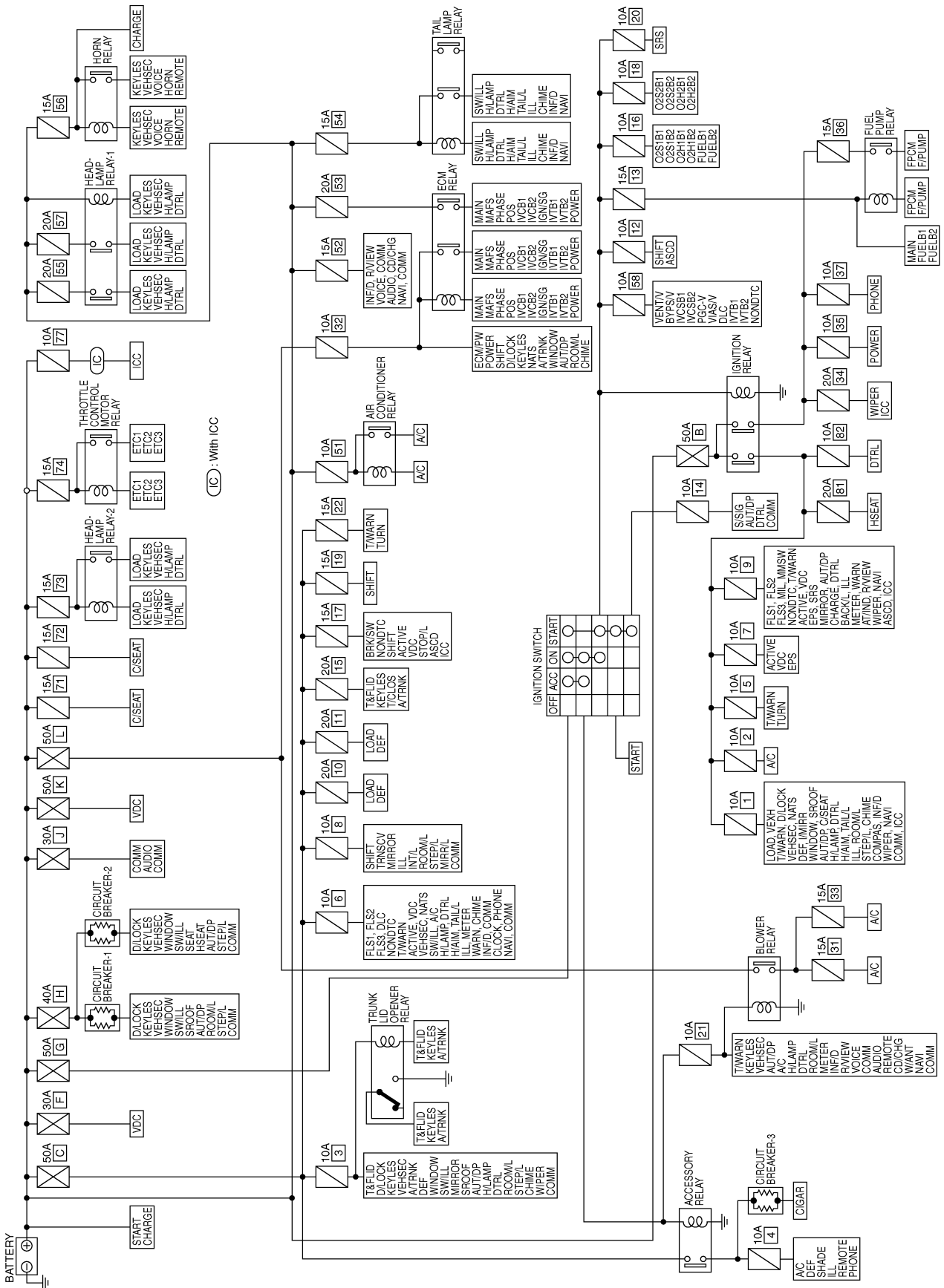

POWER SUPPLY ROUTING

Wiring Diagram — POWER — BATTERY POWER SUPPLY— IGNITION SW. IN ANY POSITION

EKS000D

PG-POWER-01

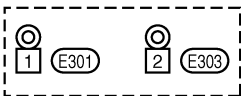
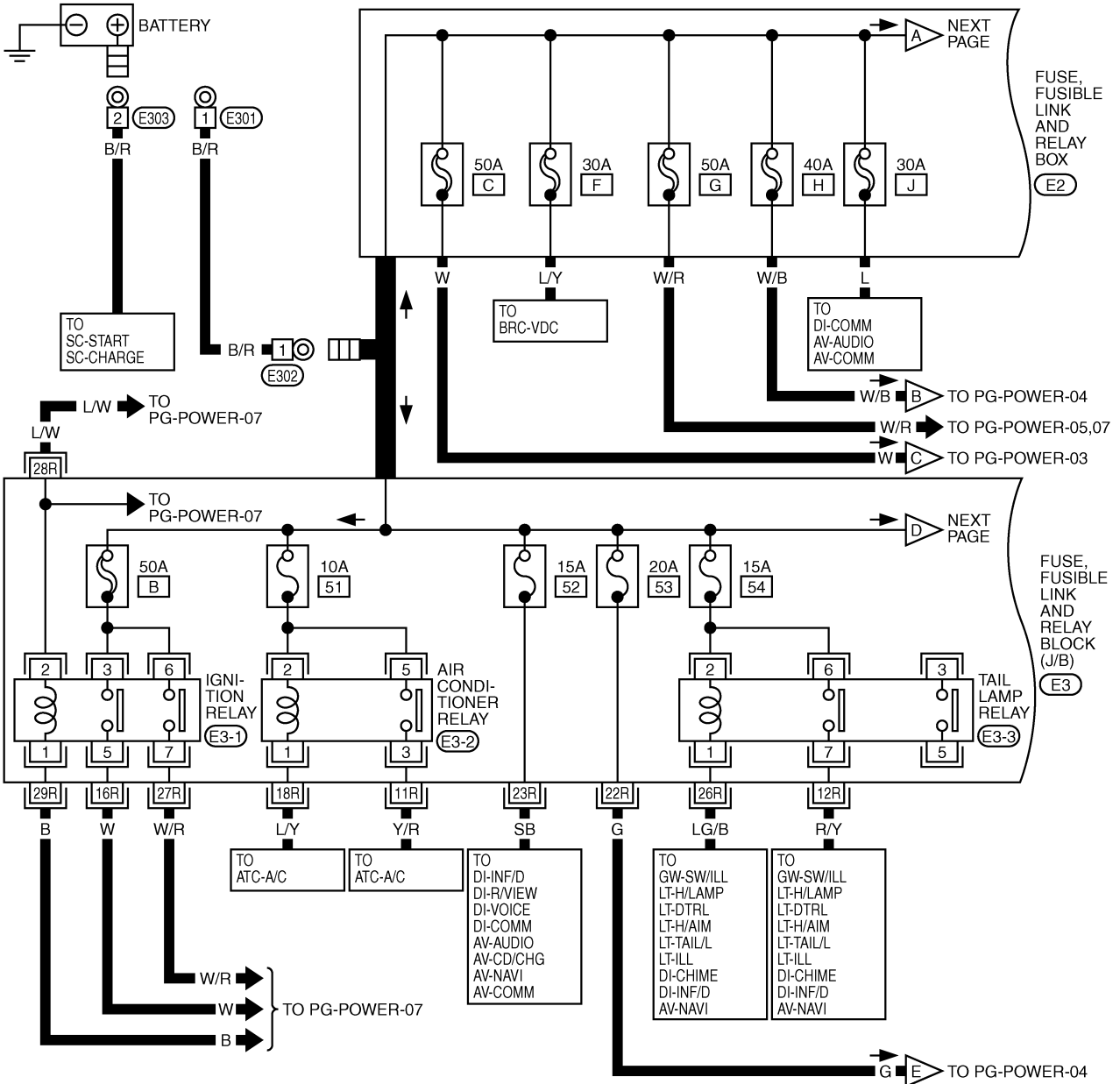

*: THIS CONNECTOR IS NOT SHOWN IN "HARNESS LAYOUT".

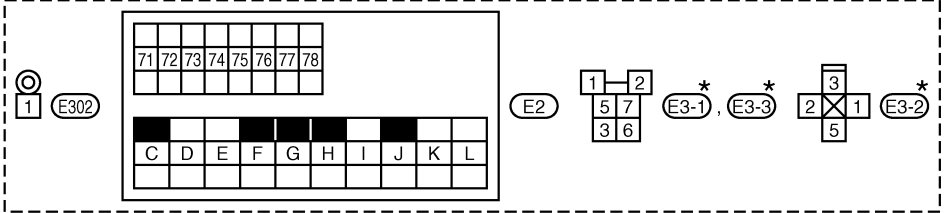
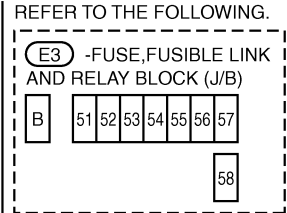

A
B
C
D
E
F
G
H
I
J
PG
L
M

POWER SUPPLY ROUTING

PG-POWER-02

U : FOR U.S.A.

C : FOR CANADA

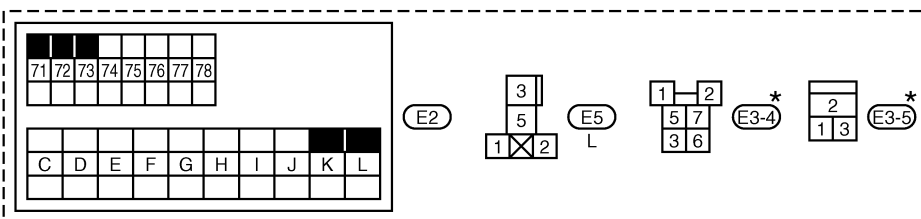
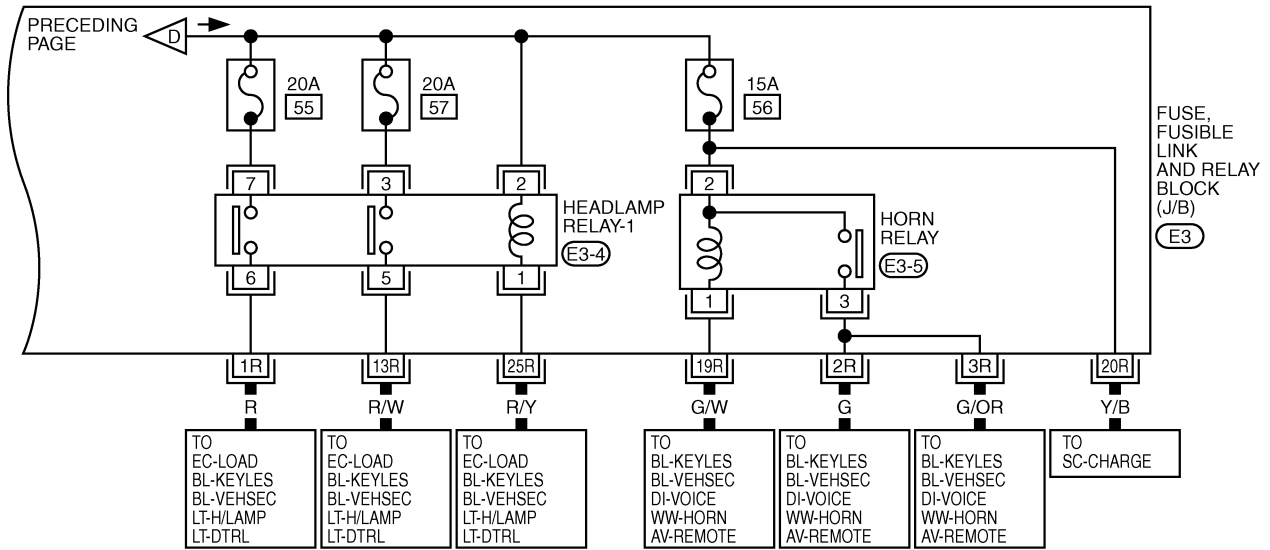
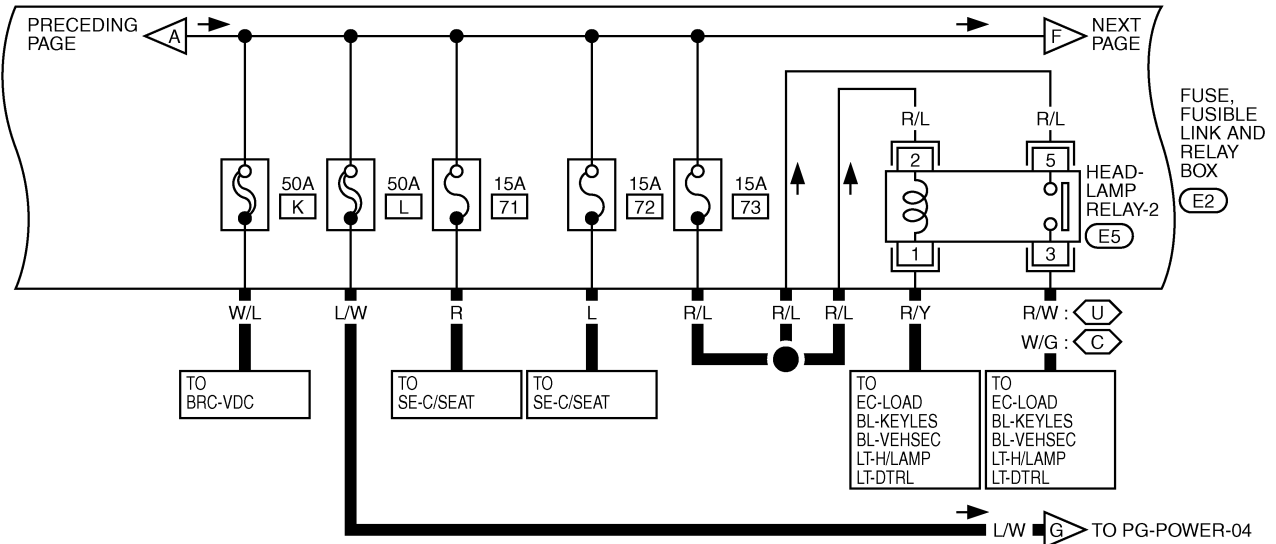

REFER TO THE FOLLOWING.

(E3) - FUSE, FUSIBLE LINK AND RELAY BLOCK (J/B)

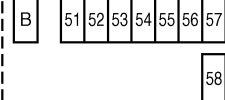

*: THIS CONNECTOR IS NOT SHOWN IN "HARNESS LAYOUT".

TKWM0356E

POWER SUPPLY ROUTING

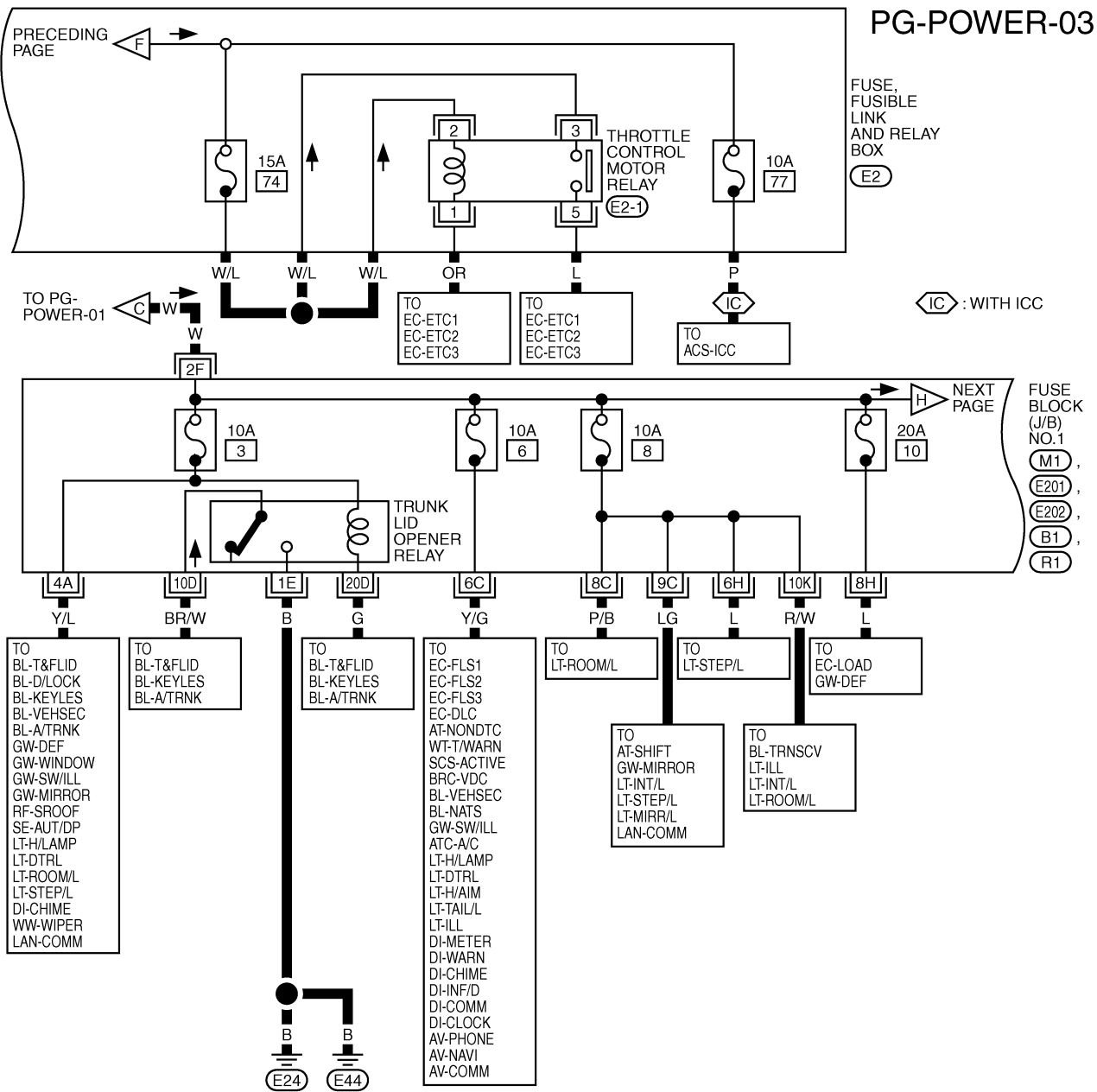

A
 B
 C
 D
 E
 F
 G
 H
 I
 J
 PG
 L
 M

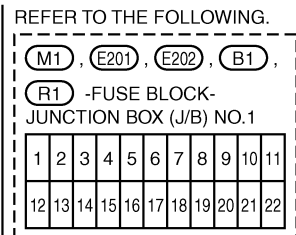
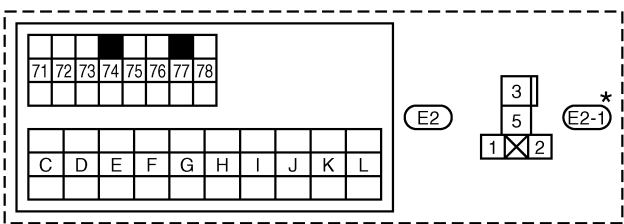

*: THIS CONNECTOR IS NOT SHOWN IN "HARNESS LAYOUT".

POWER SUPPLY ROUTING

PG-POWER-04

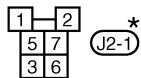
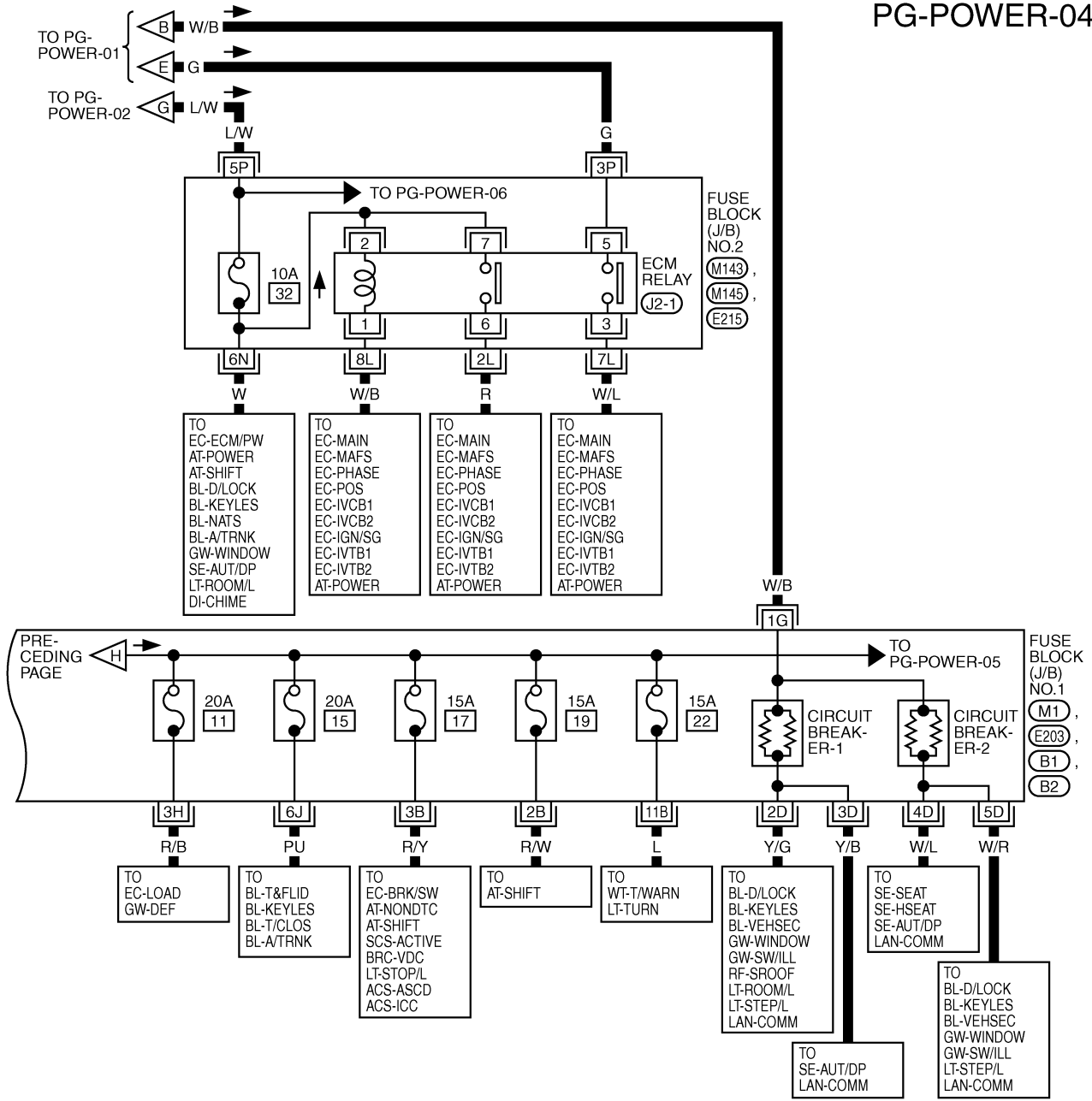

*: THIS CONNECTOR IS NOT SHOWN IN "HARNESS LAYOUT".

REFER TO THE FOLLOWING.

(M1), (E203), (B1), (B2)

-FUSE BLOCK-JUNCTION BOX (J/B) NO.1

1	2	3	4	5	6	7	8	9	10	11
12	13	14	15	16	17	18	19	20	21	22

(M143), (M145), (E215) -FUSE

BLOCK-JUNCTION BOX

(J/B) NO.2

31	32	33	34	35	36	37	38
----	----	----	----	----	----	----	----

POWER SUPPLY ROUTING

ACCESSORY POWER SUPPLY — IGNITION SW. IN "ACC" OR "ON"

PG-POWER-05

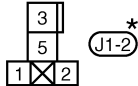
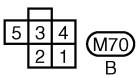
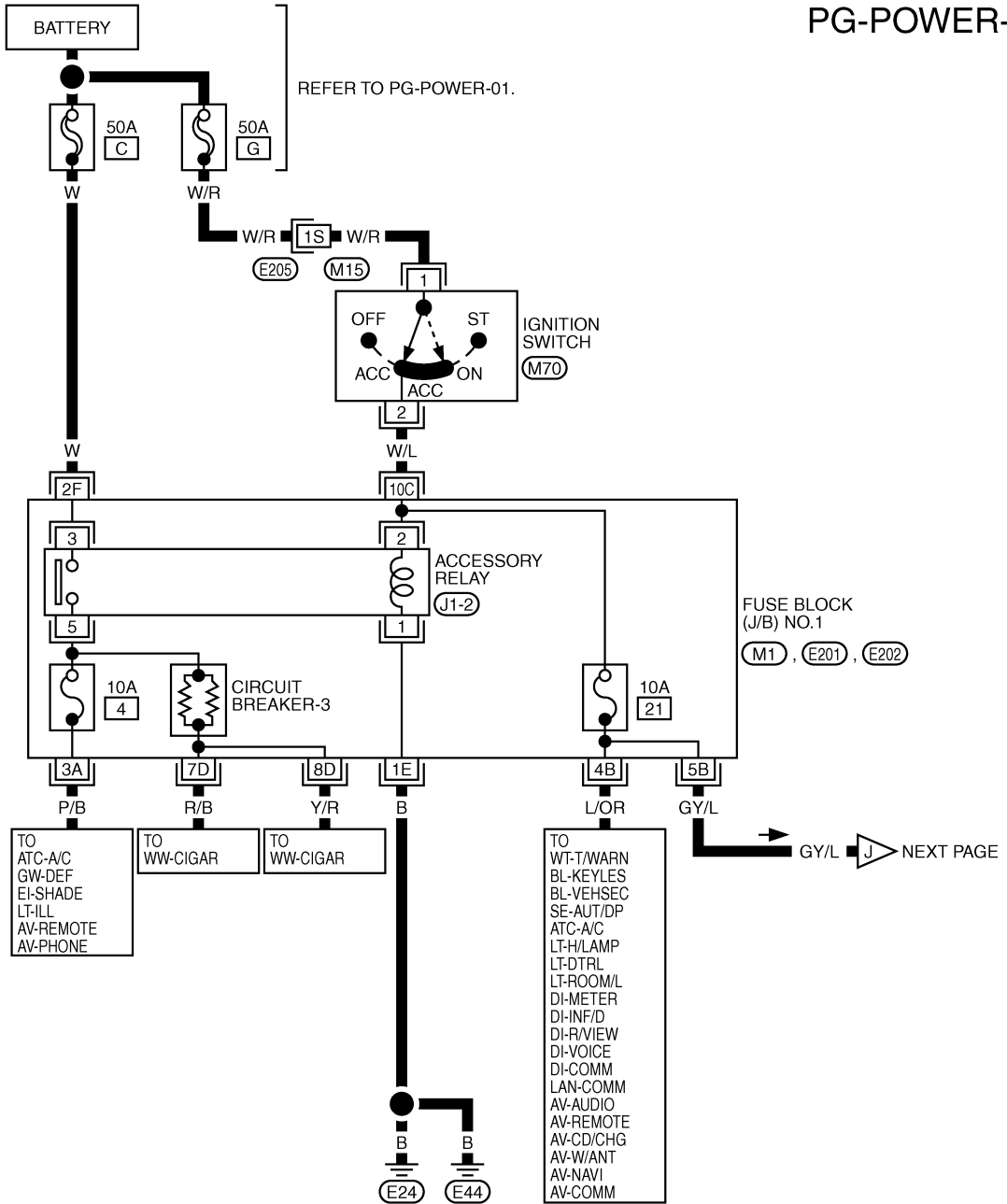

*: THIS CONNECTOR IS NOT SHOWN IN "HARNES LAYOUT".

REFER TO THE FOLLOWING.

(E205) -SUPER MULTIPLE JUNCTION (SMJ)

(M1), (E201), (E202) -FUSE BLOCK-JUNCTION BOX (J/B) NO.1

1	2	3	4	5	6	7	8	9	10	11
12	13	14	15	16	17	18	19	20	21	22

A
B
C
D
E
F
G
H
I
J
PG
L
M

POWER SUPPLY ROUTING

PG-POWER-06

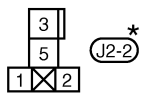
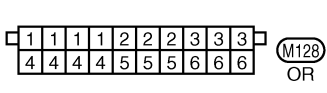
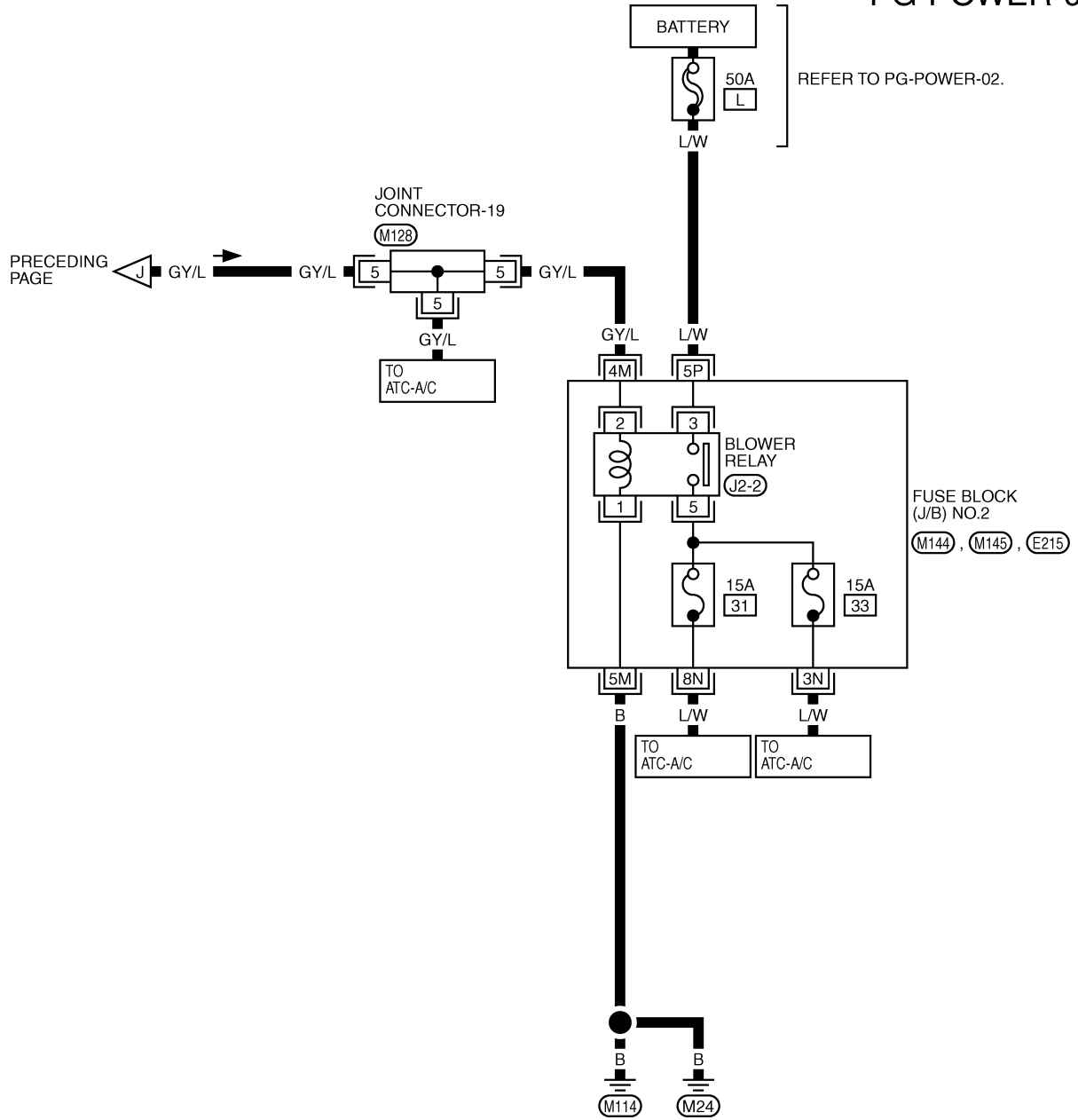

REFER TO THE FOLLOWING.

(M144), (M145), (E215) - FUSE BLOCK-JUNCTION BOX (J/B) NO.2

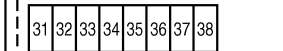

*: THIS CONNECTOR IS NOT SHOWN IN "HARNESS LAYOUT".

TKWM0450E

POWER SUPPLY ROUTING

IGNITION POWER SUPPLY — IGNITION SW. IN “ON” AND/OR “START”

PG-POWER-07

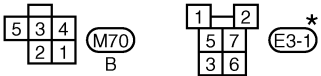
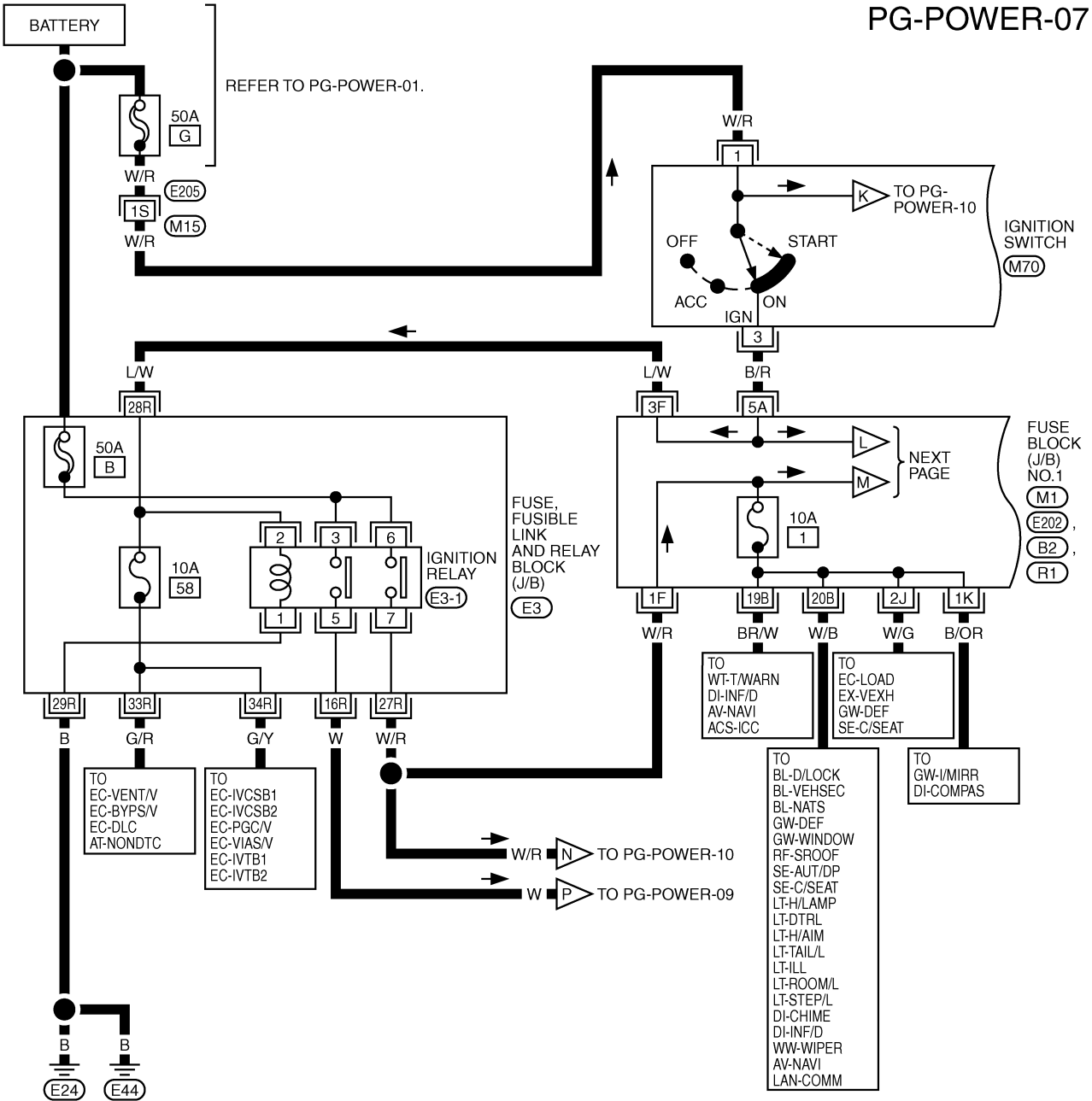

*: THIS CONNECTOR IS NOT SHOWN IN "HARNESS LAYOUT".

REFER TO THE FOLLOWING.

(E205) -SUPER MULTIPLE JUNCTION (SMJ)

(M1), (E202), (B2), (R1) -FUSE BLOCK-JUNCTION BOX (J/B) NO.1

1	2	3	4	5	6	7	8	9	10	11
12	13	14	15	16	17	18	19	20	21	22

(E3) -FUSE,FUSIBLE LINK AND RELAY BLOCK (J/B)

B	51	52	53	54	55	56	57
---	----	----	----	----	----	----	----

58

POWER SUPPLY ROUTING

PG-POWER-08

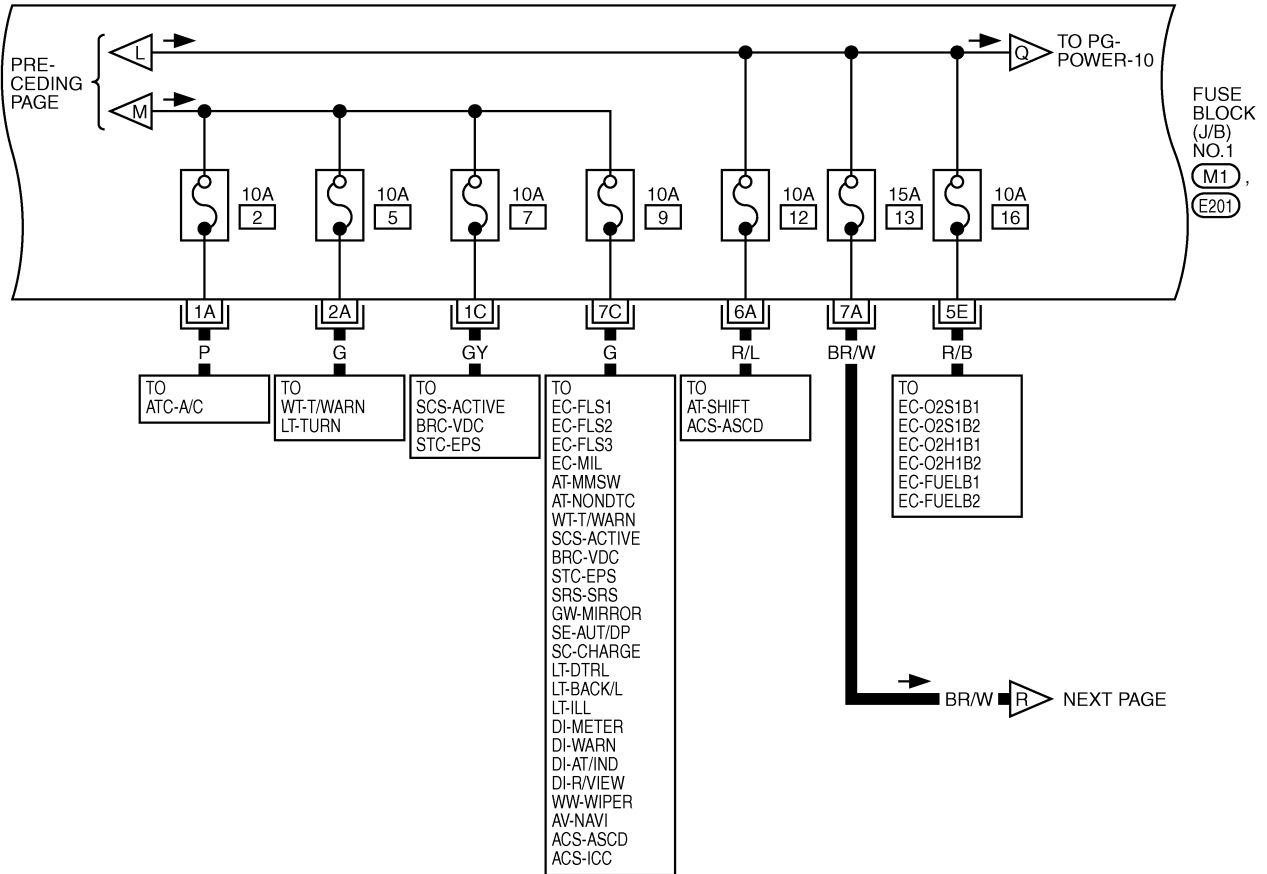

REFER TO THE FOLLOWING.

(M1), (E201)

-FUSE BLOCK-JUNCTION
BOX (J/B) NO.1

1	2	3	4	5	6	7	8	9	10	11
12	13	14	15	16	17	18	19	20	21	22

TKWM0368E

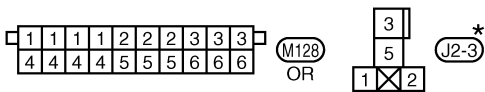
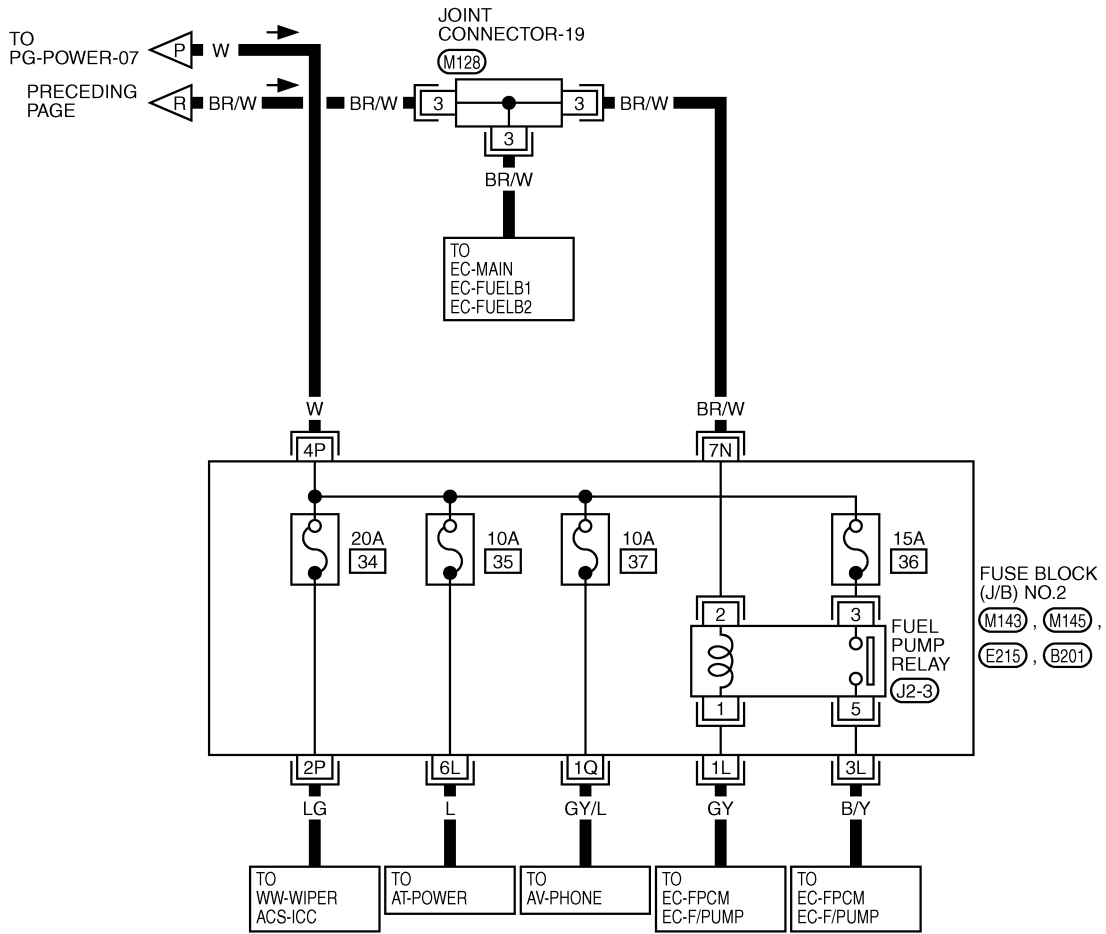

*: THIS CONNECTOR IS NOT SHOWN IN "HARNESS LAYOUT".

REFER TO THE FOLLOWING.

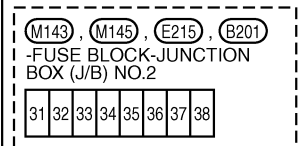

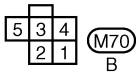
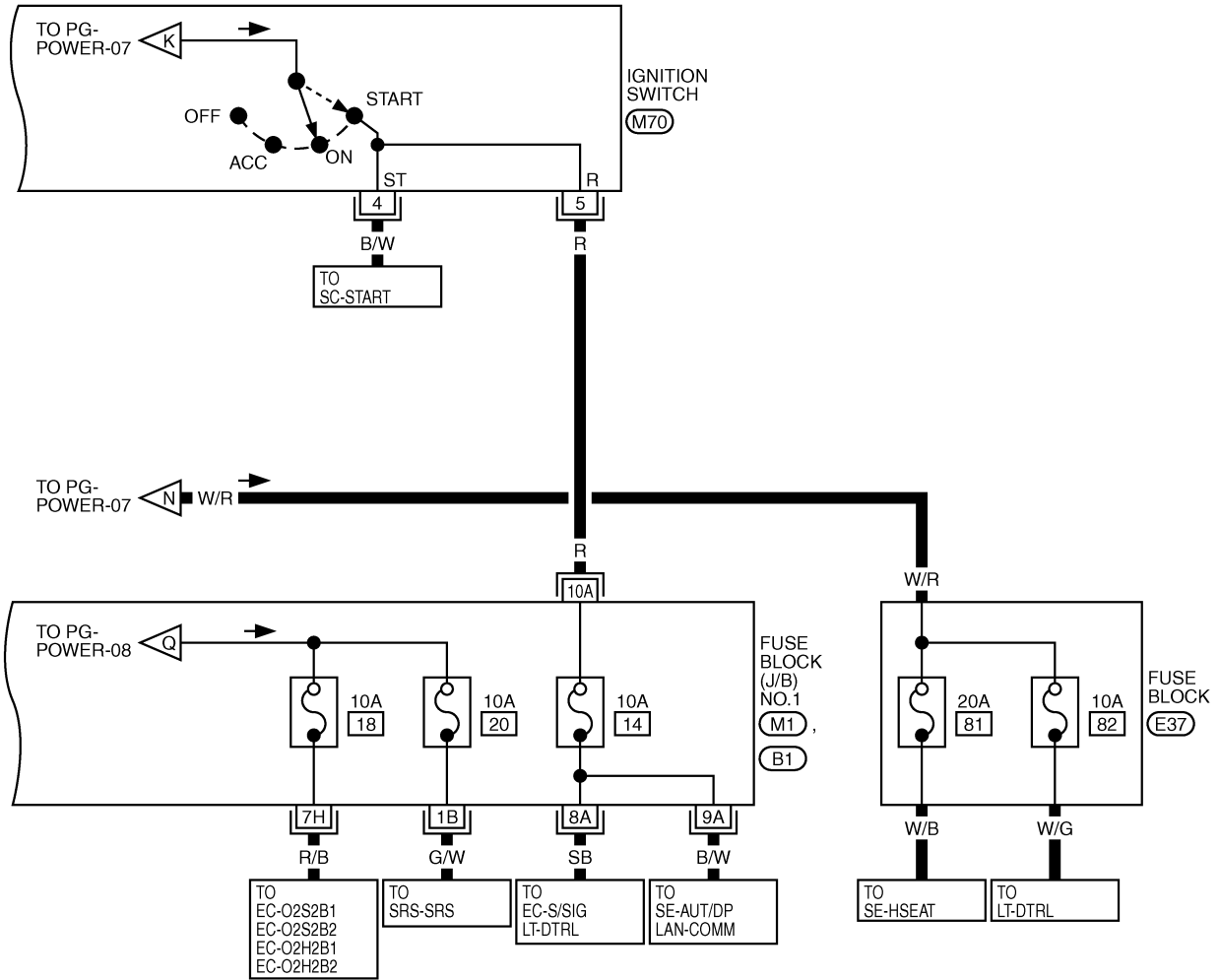

REFER TO THE FOLLOWING.

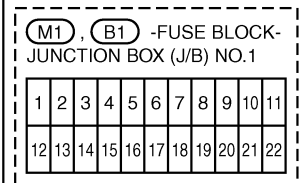

POWER SUPPLY ROUTING

Fuse

- If fuse is blown, be sure to eliminate cause of incident before installing new fuse.
- Use fuse of specified rating. Never use fuse of more than specified rating.
- Do not partially install fuse; always insert it into fuse holder properly.
- Remove fuse for "ELECTRICAL PARTS (BAT)" if vehicle is not used for a long period of time.

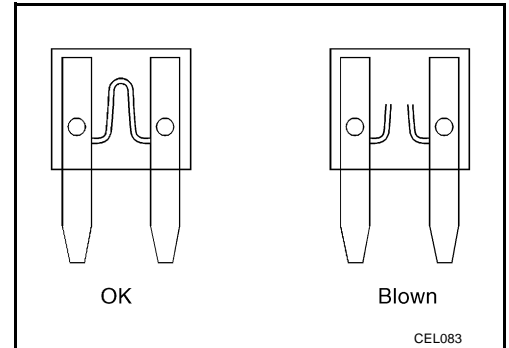

Fusible Link

A melted fusible link can be detected either by visual inspection or by feeling with finger tip. If its condition is questionable, use circuit tester or test lamp.

CAUTION:

- If fusible link should melt, it is possible that critical circuit (power supply or large current carrying circuit) is shorted. In such a case, carefully check and eliminate cause of incident.
- Never wrap outside of fusible link with vinyl tape. Important: Never let fusible link touch any other wiring harness, vinyl or rubber parts.

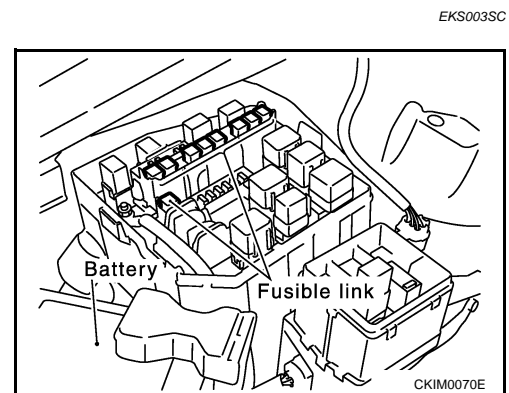

Circuit Breaker

The PTC thermistor generates heat in response to current flow. The temperature (and resistance) of the thermistor element varies with current flow. Excessive current flow will cause the element's temperature to rise. When the temperature reaches a specified level, the electrical resistance will rise sharply to control the circuit current. Reduced current flow will cause the element to cool. Resistance falls accordingly and normal circuit current flow is allowed to resume.

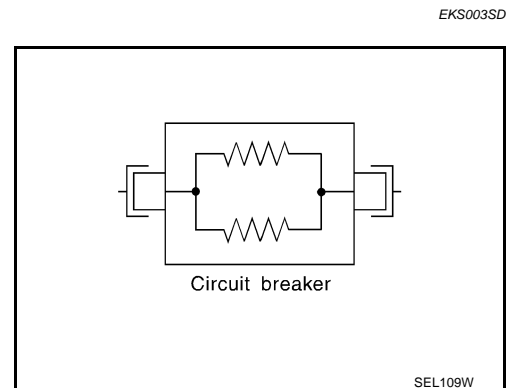

A
B
C
D
E
F
G
H
I
J
PG
L
M

GROUND

PFP:00011

EKS000DR

GROUND

Ground Distribution MAIN HARNESS

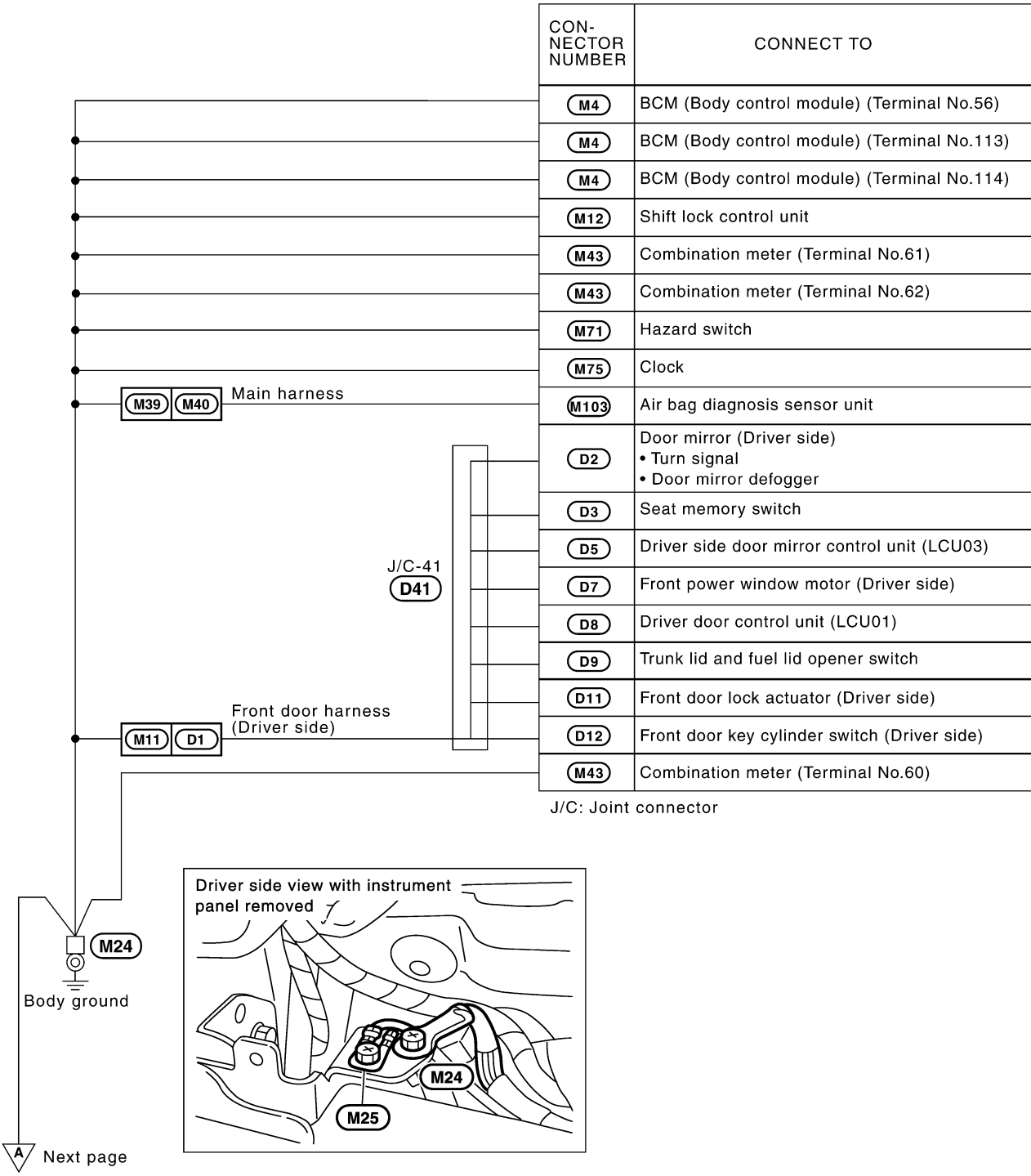

GROUND

A
B
C
D
E
F
G
H
I
J
PG
L
M

A Preceding page

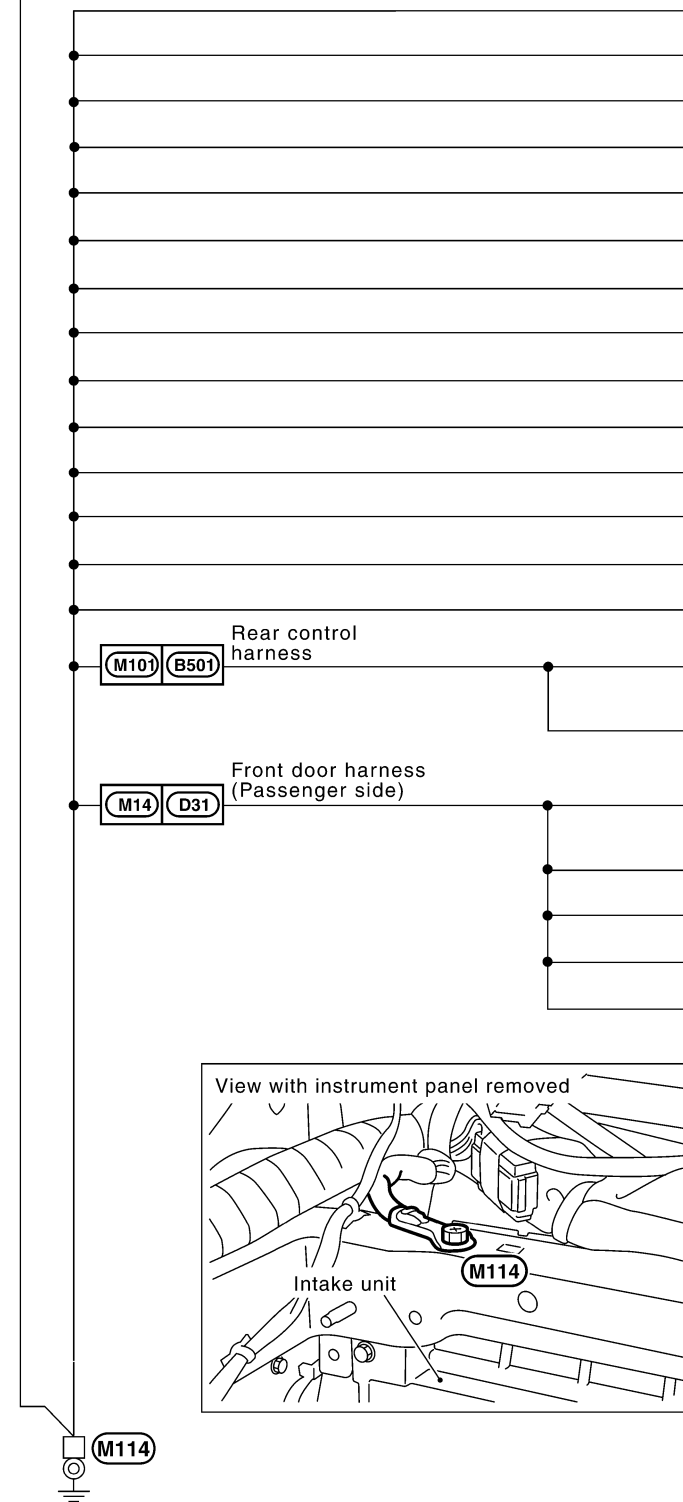

CON-NECTOR NUMBER	CONNECT TO
M82	Display (Terminal No. 22)
M82	Display (Terminal No. 24)
M83	Multifunction switch
M91	Combination flasher unit
M92	Front cigarette lighter socket
M96	Handset (Option)
M97	A/T device
M100	Front power socket
M102	Console box lamp
M106	Mode door motor (Passenger side)
M107	Air mix door motor (Passenger side)
M108	Power steering control unit
M109	CD auto changer
M144	Fuse block (J/B) No. 2 • Blower relay
B503	Rear sunshade rear switch (Terminal No. 5) (Without rear control switch)
B503	Rear sunshade rear switch (Terminal No. 3) (Without rear control switch)
D32	Door mirror (Passenger side) • Turn signal • Door mirror defogger
D35	Passenger side door mirror control unit (LCU04)
D37	Front power window motor (Passenger side)
D39	Passenger door control unit
D41	Front door lock actuator (Passenger side)

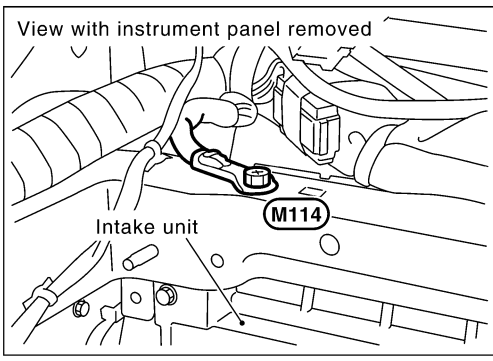

M114
Body ground

CKIM0273E

GROUND

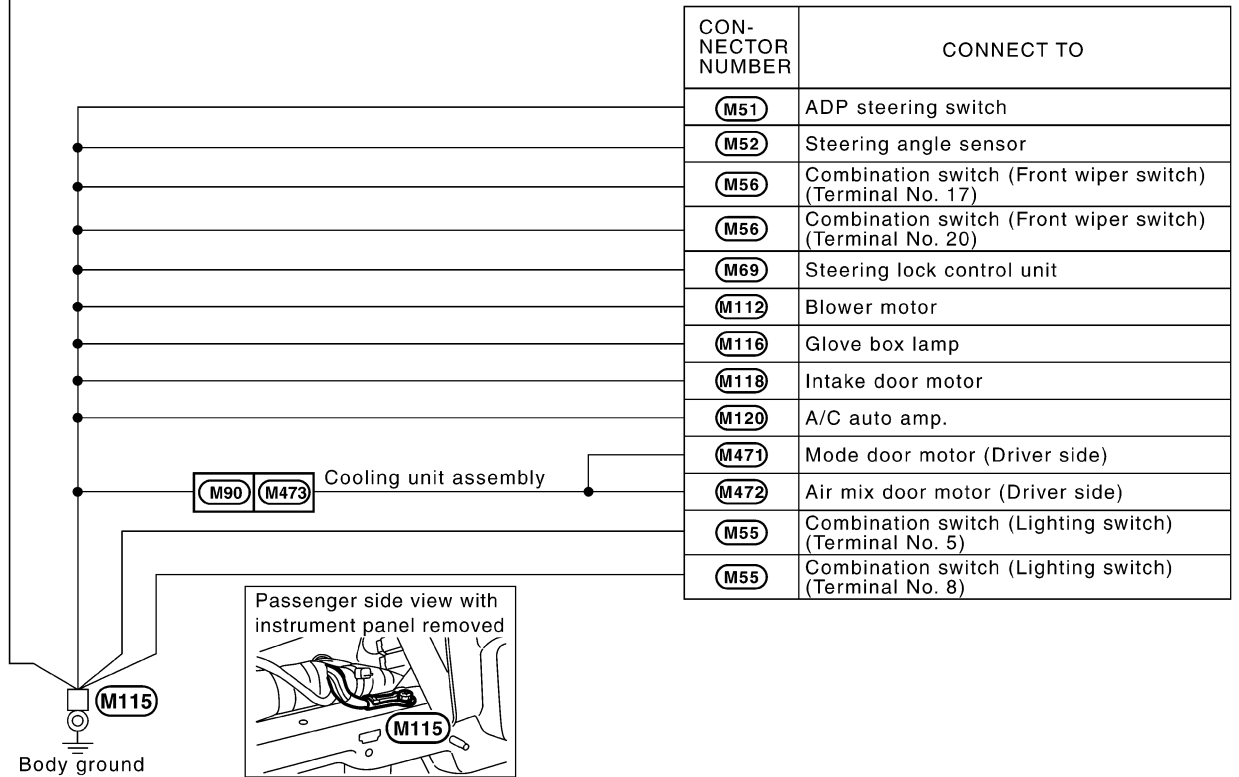
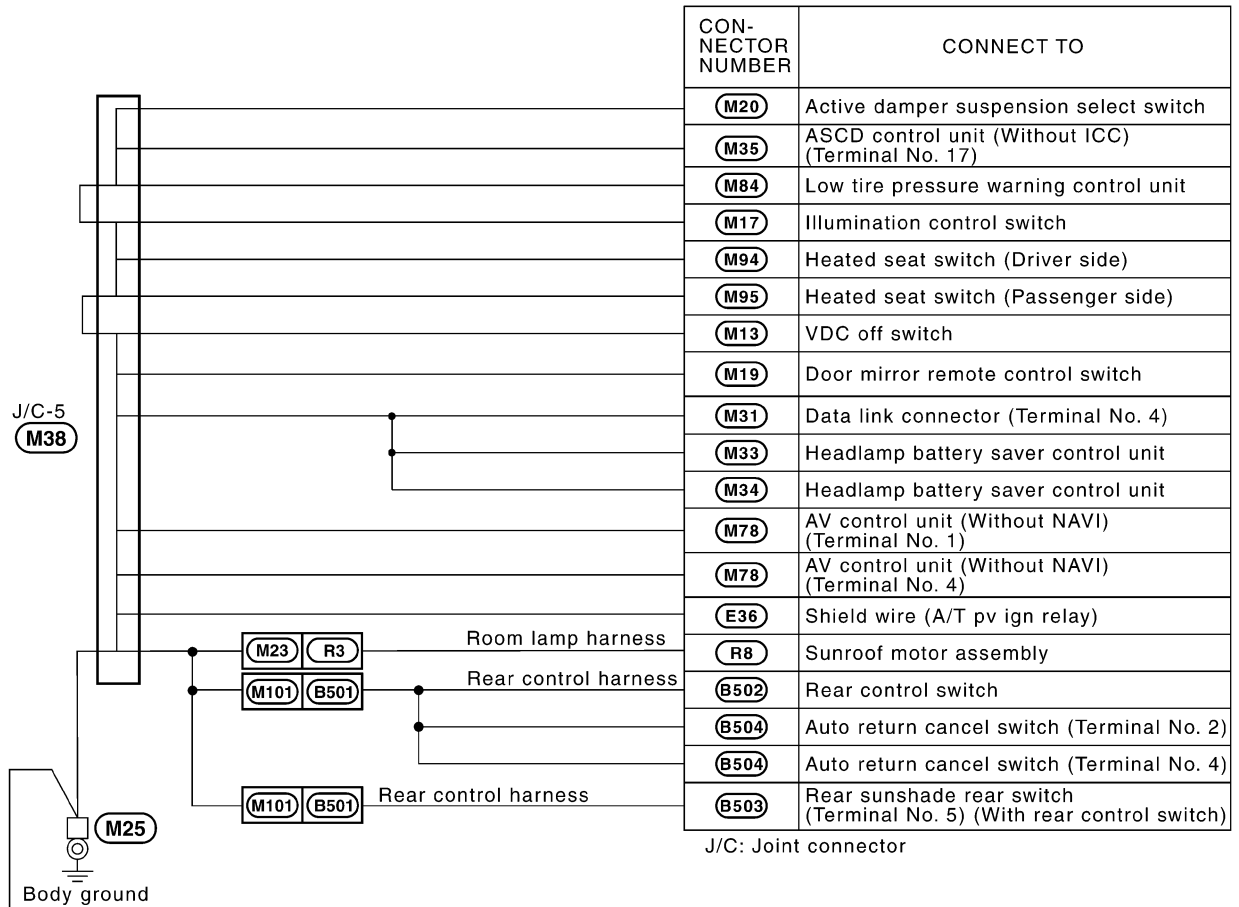

CKIM0244E

GROUND

ENGINE ROOM HARNESS

A
B
C
D
E
F
G
H
I
J
PG
L
M

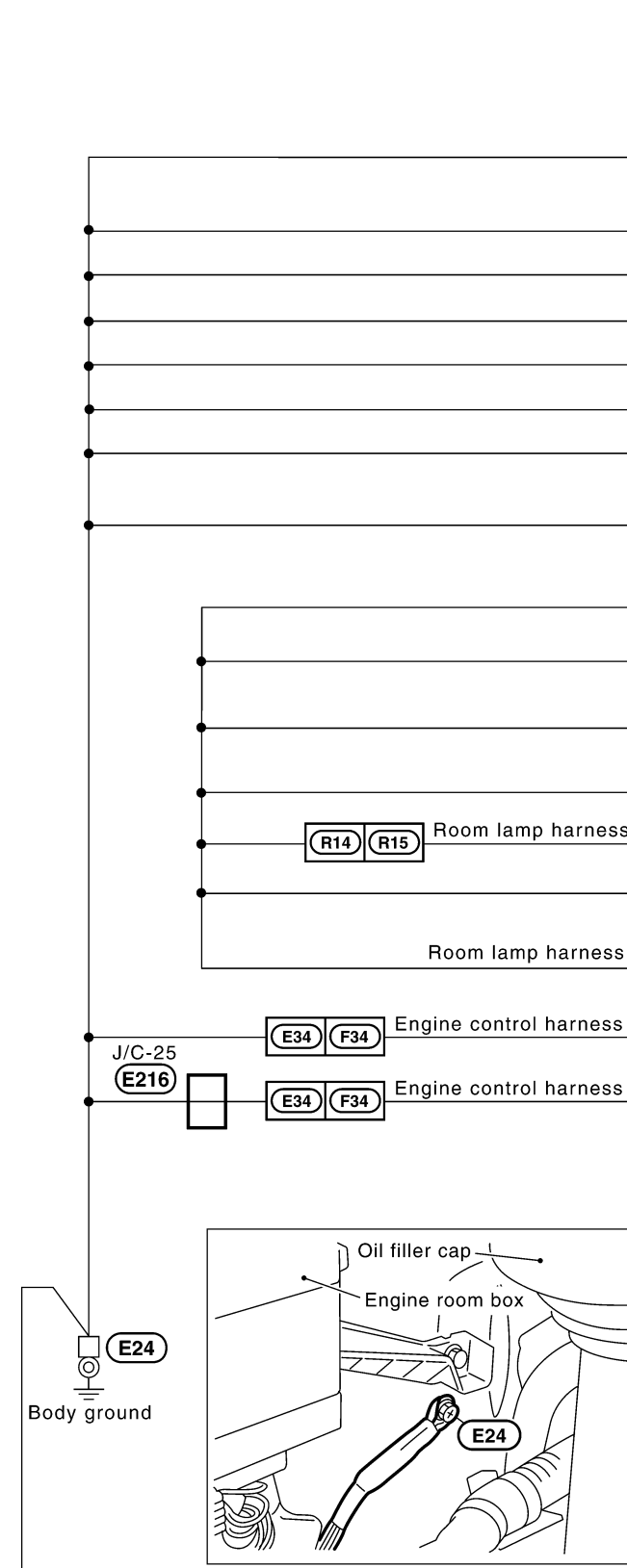

CON-NECTOR NUMBER	CONNECT TO
E3	Fuse, fusible link and relay block (J/B) (Terminal No. 29R) • Ignition relay • Park/Neutral position relay
E4	Front wiper relay
E31	Front shock absorber actuator RH
E36	A/T pv ign relay
E38	ICC brake hold relay (With ICC)
E52	ICC sensor (With ICC)
E74	Brake fluid level switch
E201	Fuse block (J/B) No. 1 (Terminal No. 1E) • Accessory relay • Trunk lid opener relay
R1	Fuse block (J/B) No. 1 (Terminal No. 5K)
R5	Vanity mirror lamp (Driver side) • Homelink universal transceiver
R13	Rear interior lamp • Personal lamp LH • Personal lamp RH
R11	Rear sunshade front switch
R9	Auto anti-dazzling inside mirror • Compass
R12	Vanity mirror lamp (Passenger side)
R6	Front interior lamp • Map lamp LH • Map lamp RH • Interior lamp ill switch
F3	Power steering solenoid valve
F103	Shield wire [(TCM (Transmission control module)] (For circuit from terminal No. 2)

J/C: Joint connector

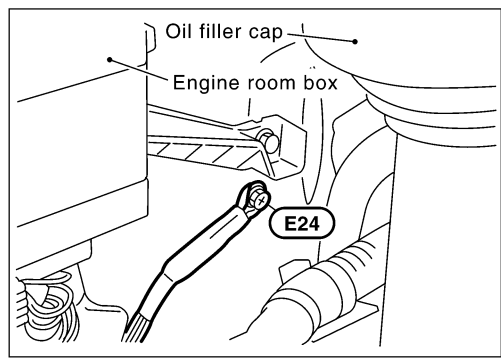

A Next page

GROUND

A Preceding page

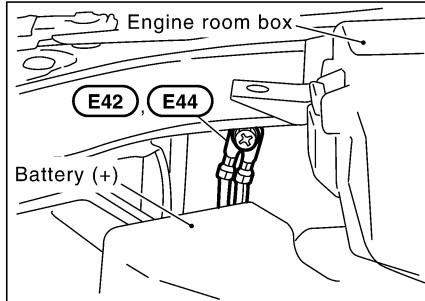
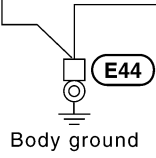

CON-NECTOR NUMBER	CONNECT TO
E65	Front combination lamp LH (Terminal No. 6) • Parking

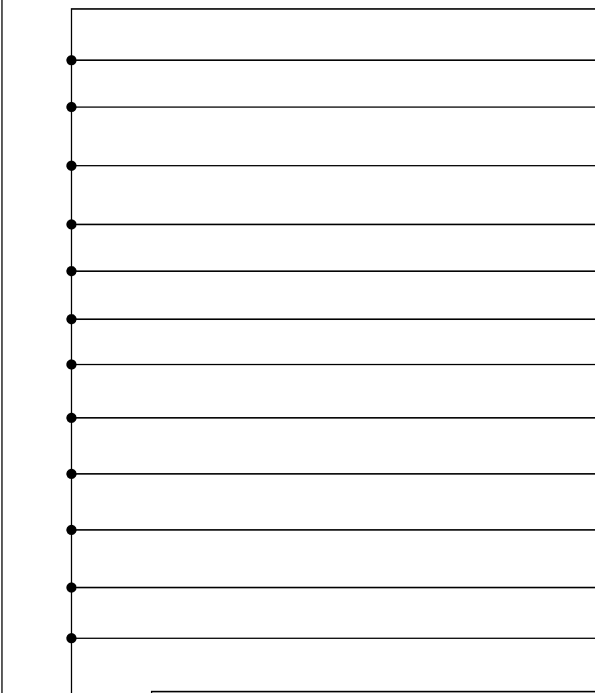
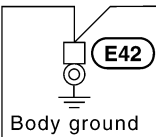

CON-NECTOR NUMBER	CONNECT TO
E45	Front combination lamp RH (Terminal No. 8) • Headlamp
E26	Daytime light control unit
E45	Front combination lamp RH (Terminal No. 2) • Turn signal
E46	Front combination lamp RH (Terminal No. 10) • Headlamp aiming motor
E46	Front combination lamp RH (Terminal No. 16) • Side marker
E47	Washer level switch
E54	Hood switch
E61	Front shock absorber actuator LH
E65	Front combination lamp LH (Terminal No. 2) • Turn signal
E65	Front combination lamp LH (Terminal No. 8) • Headlamp
E66	Front combination lamp LH (Terminal No. 10) • Headlamp aiming motor
E66	Front combination lamp LH (Terminal No. 16) • Side marker
E75	Front wiper motor
E76	Climate controlled seat relay
E45	Front combination lamp RH (Terminal No. 6) • Parking

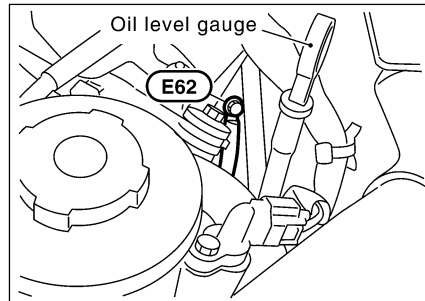
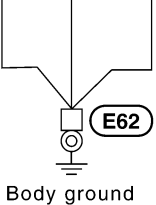

CKIM0143E

GROUND

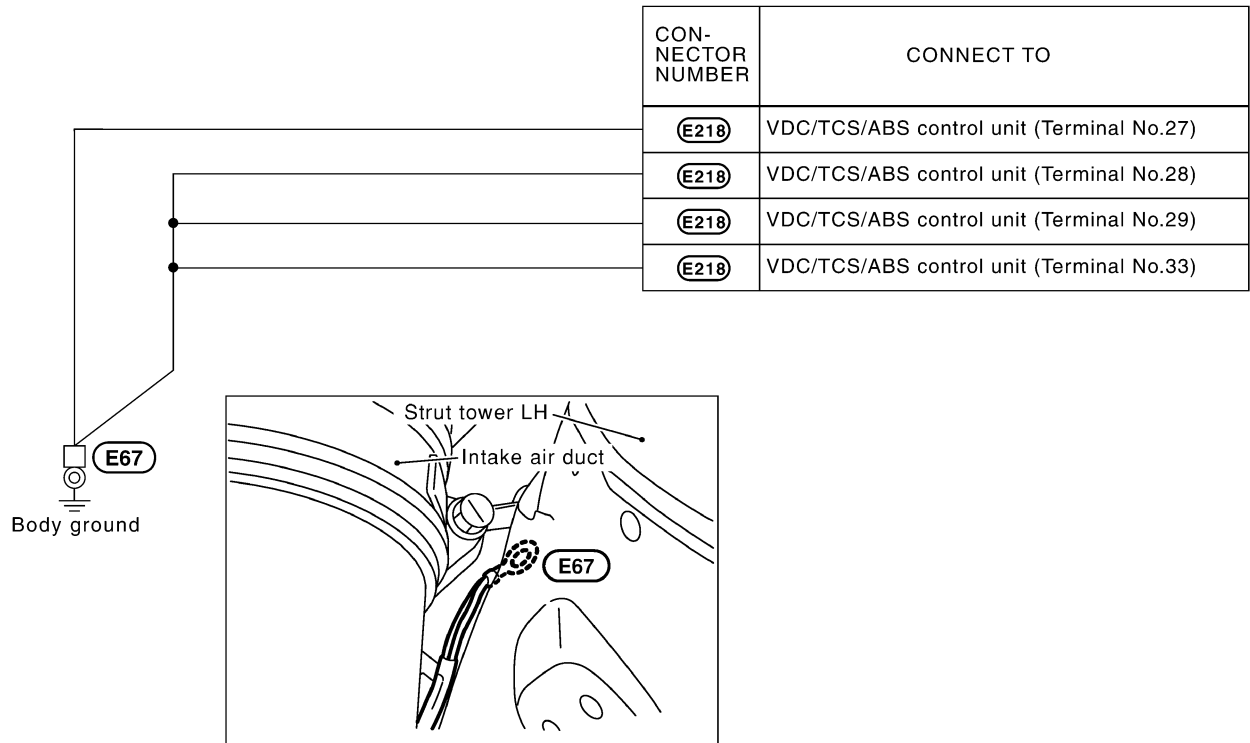
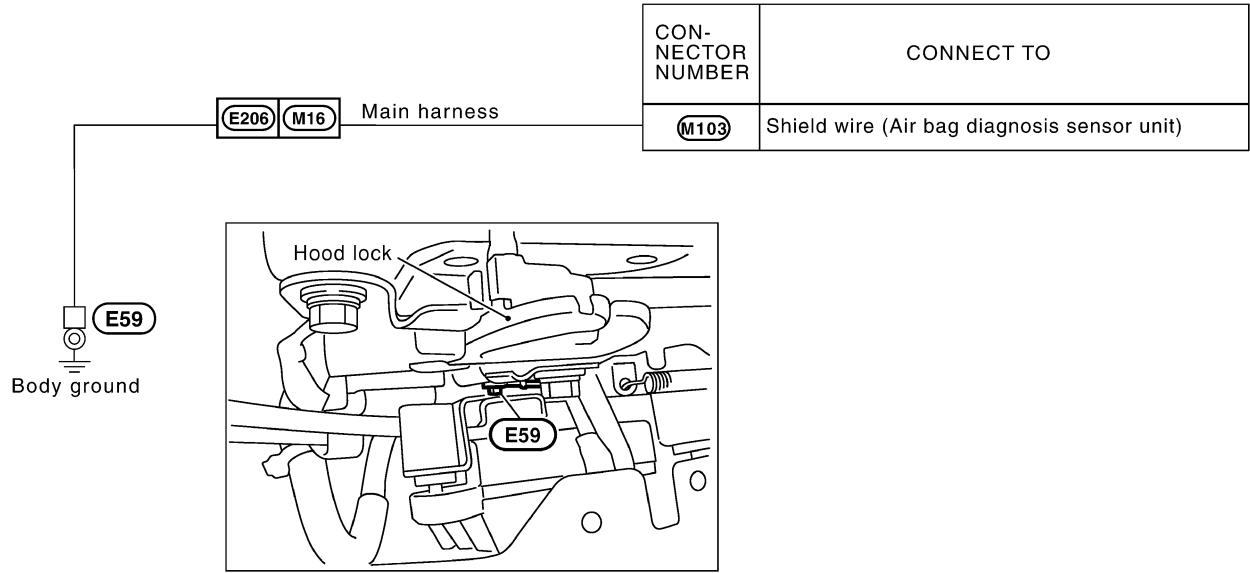

CKIM0156E

A
B
C
D
E
F
G
H
I
J
PG
L
M

GROUND

ENGINE HARNESS

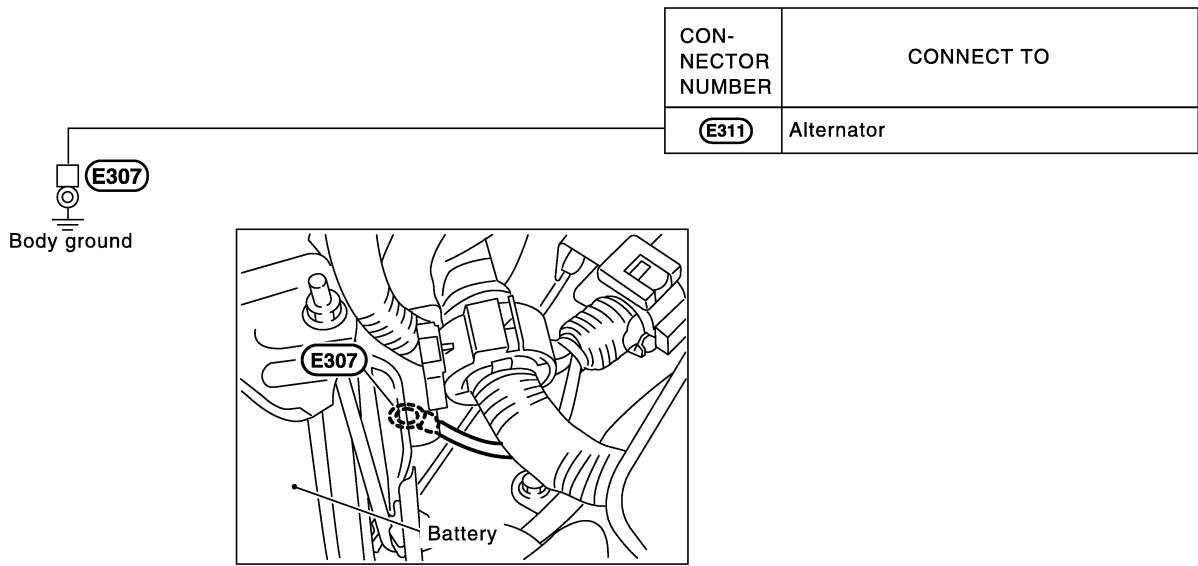

CKIM0018E

GROUND

ENGINE CONTROL HARNESS

A
B
C
D
E
F
G
H
I
J
PG
L
M

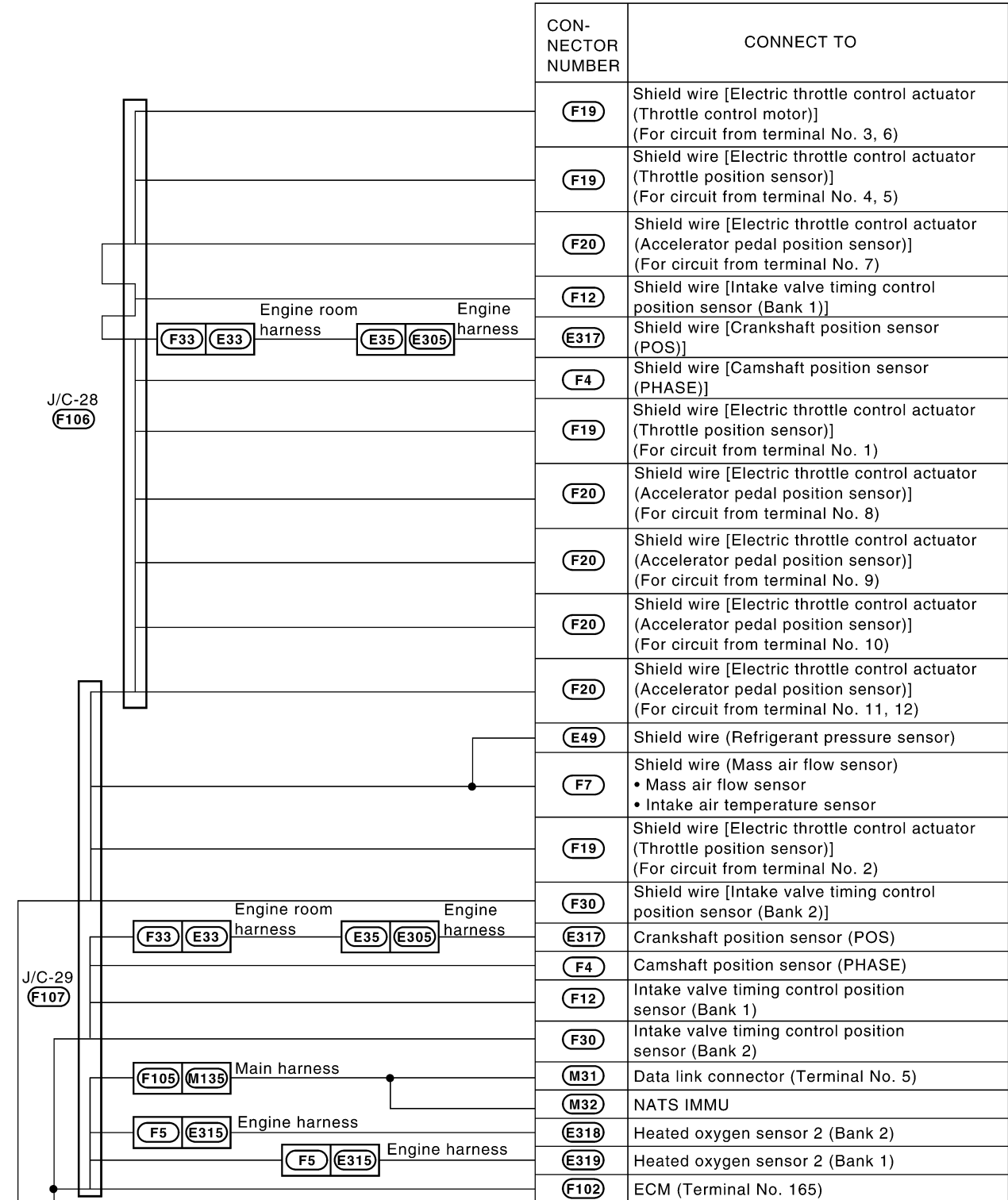

J/C: Joint connector

Next page

CKIM0144E

GROUND

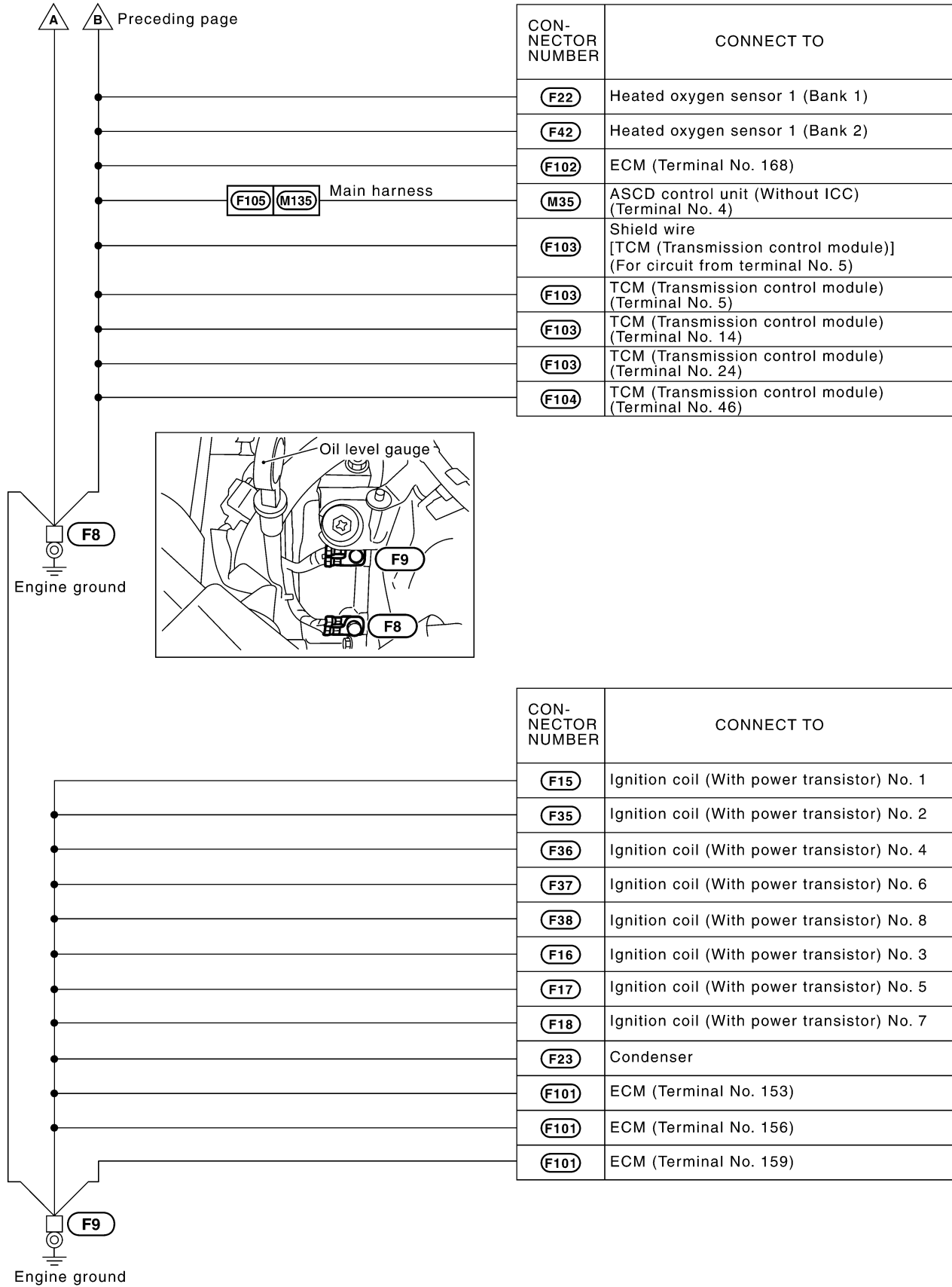

CKIM0157E

GROUND

BODY HARNESS

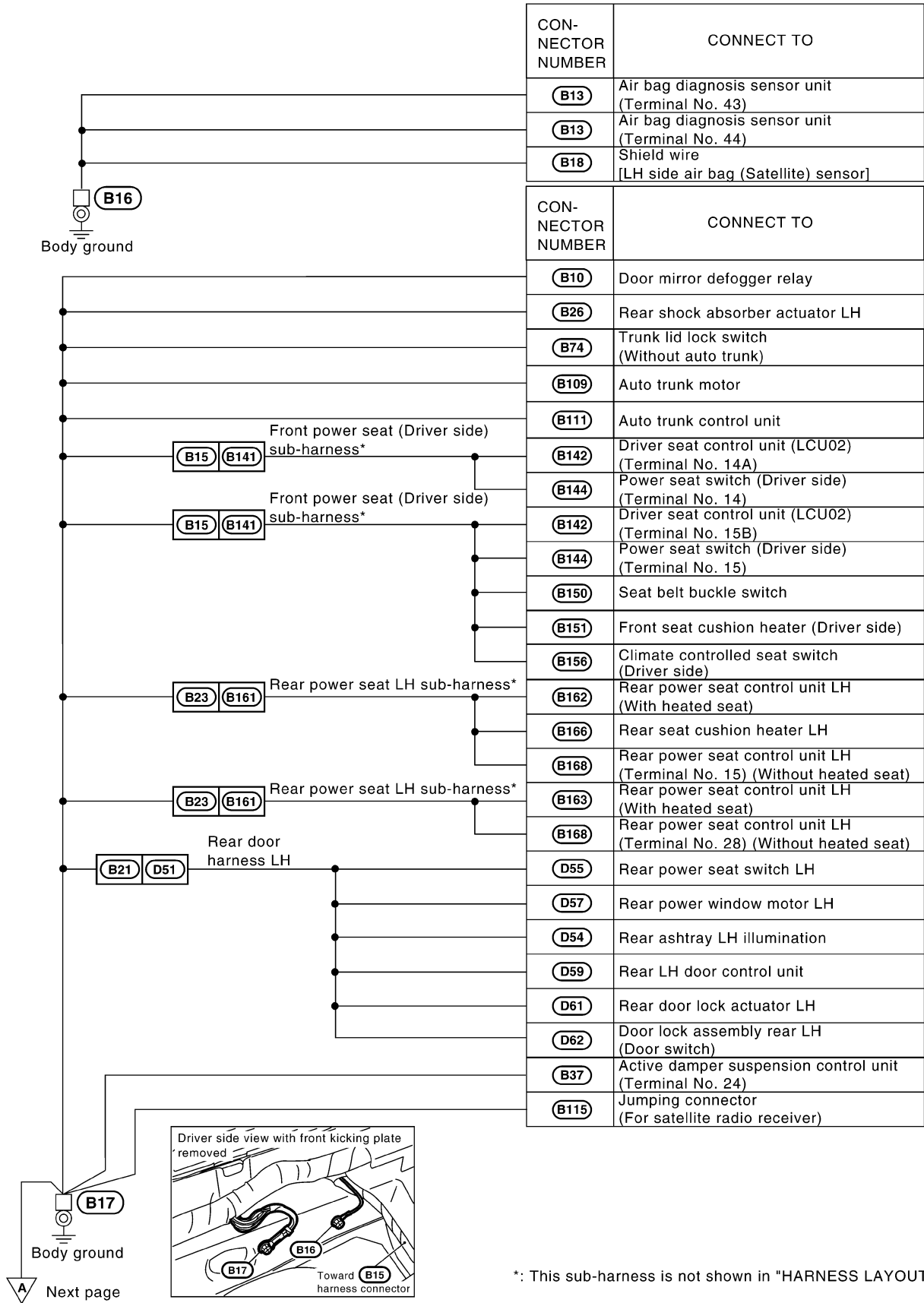

*: This sub-harness is not shown in "HARNES LAYOUT".

GROUND

A Preceding page

CON-NECTOR NUMBER	CONNECT TO
B45	Dropping resistor
B30	AV and NAVI control unit (With NAVI) (Terminal No. 1)
B30	AV and NAVI control unit (With NAVI) (Terminal No. 4)
B37	Active damper suspension control unit (Terminal No. 8)
B37	Active damper suspension control unit (Terminal No. 23)
B46	Trunk lid key cylinder switch (Unlock switch) (Without auto trunk)
B47	License lamp LH (Without auto trunk)
B48	License lamp RH (Without auto trunk)
B50	Rear view camera (Without auto trunk)
B53	Rear combination lamp LH • Stop/Tail • Back-up • Turn signal
B55	Trunk lid striker switch
B56	Trunk closure control unit
B58	Rear combination lamp RH • Stop/Tail • Back-up • Turn signal
B69	Voice activated control module
B73	Dual mode muffler control unit

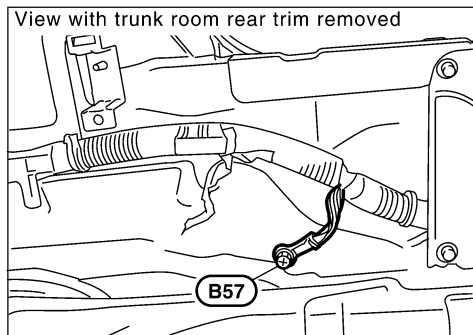
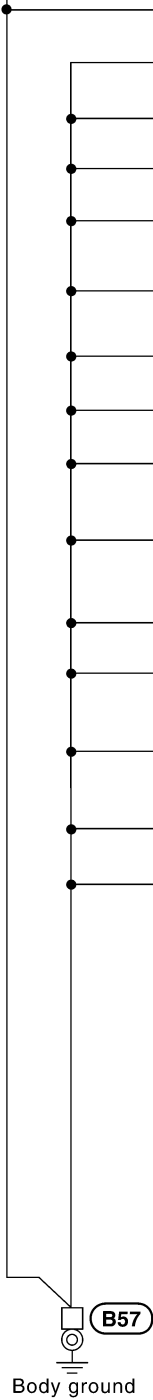

CKIM0187E

GROUND

BODY NO.2 HARNESS

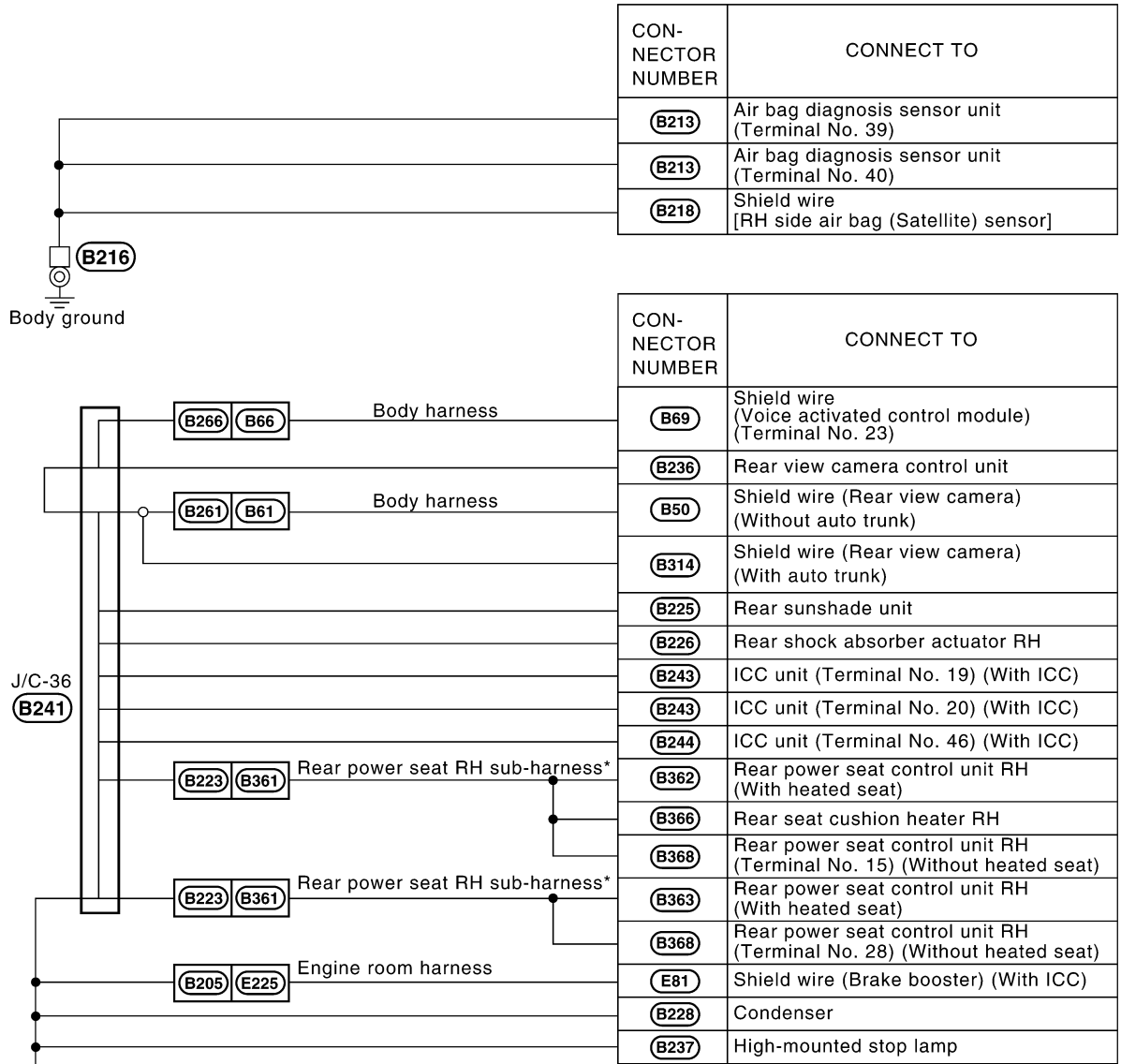

J/C: Joint connector

Next page

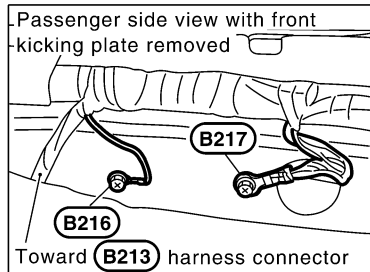

*: This sub-harness is not shown in "HARNESS LAYOUT".

GROUND

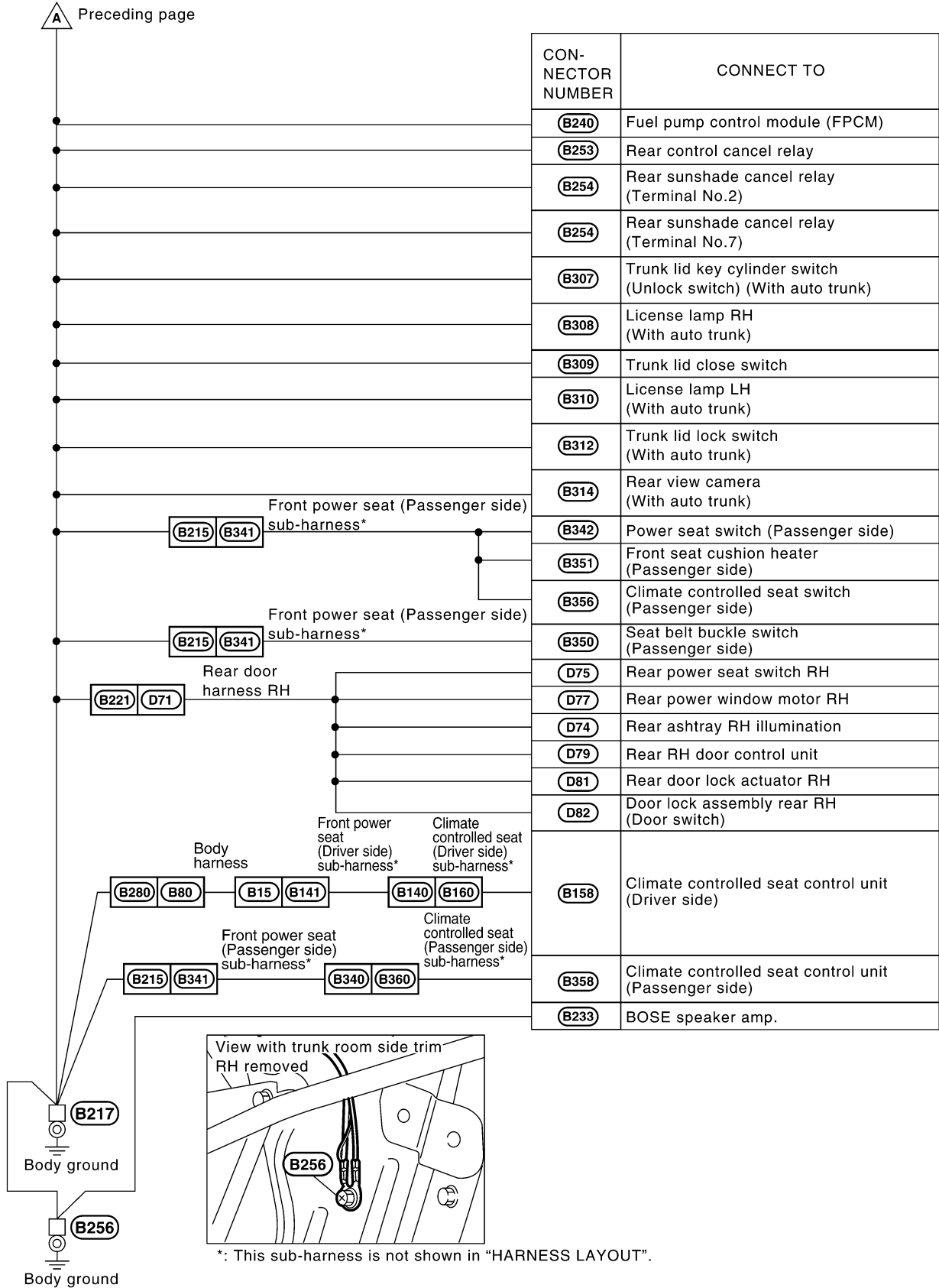

CKIM0274E

GROUND

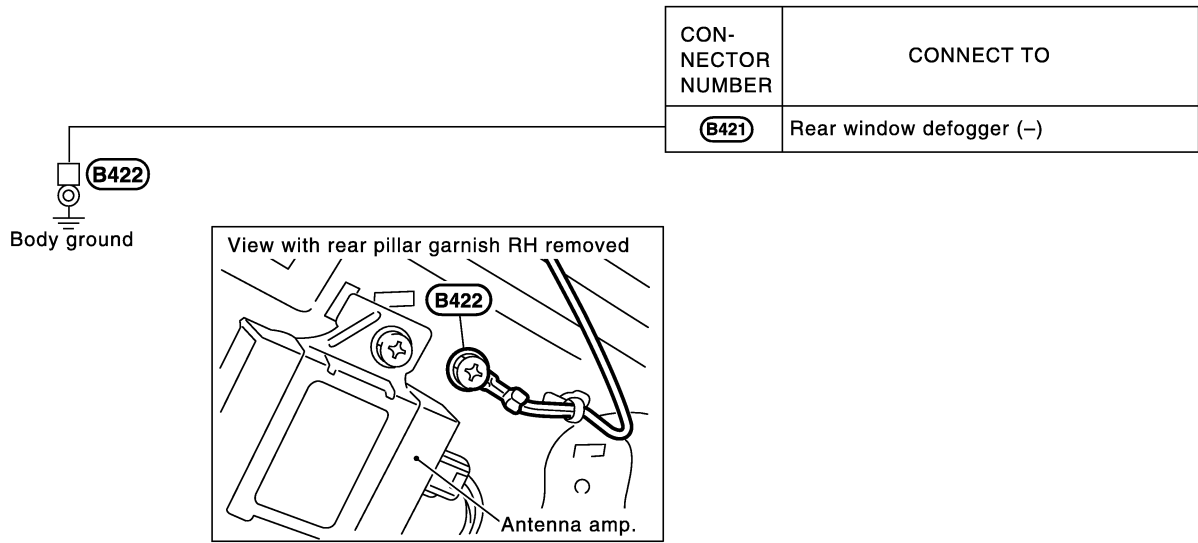

CKIM0024E

A
B
C
D
E
F
G
H
I
J
PG
L
M

HARNESS

PFP:00011

Harness Layout HOW TO READ HARNESS LAYOUT

EKS000DS

The following Harness Layouts use a map style grid to help locate connectors on the drawings:

- Main Harness
- Engine Room Harness (Engine Compartment)
- Engine Control Harness
- Body Harness and Rear Control Harness
- Body No.2 Harness





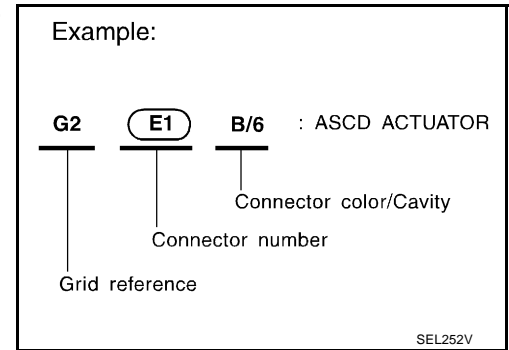





To use the grid reference

1. Find the desired connector number on the connector list.
2. Find the grid reference.
3. On the drawing, find the crossing of the grid reference letter column and number row.
4. Find the connector number in the crossing zone.
5. Follow the line (if used) to the connector.



CONNECTOR SYMBOL

Main symbols of connector (in Harness Layout) are indicated in the below.

Connector type	Water proof type		Standard type	
	Male	Female	Male	Female
<ul style="list-style-type: none"> • Cavity: Less than 4 • Relay connector 				
<ul style="list-style-type: none"> • Cavity: From 5 to 8 				
<ul style="list-style-type: none"> • Cavity: More than 9 	—	—		
<ul style="list-style-type: none"> • Ground terminal etc. 	—			

SKIA0404E

HARNESS

OUTLINE

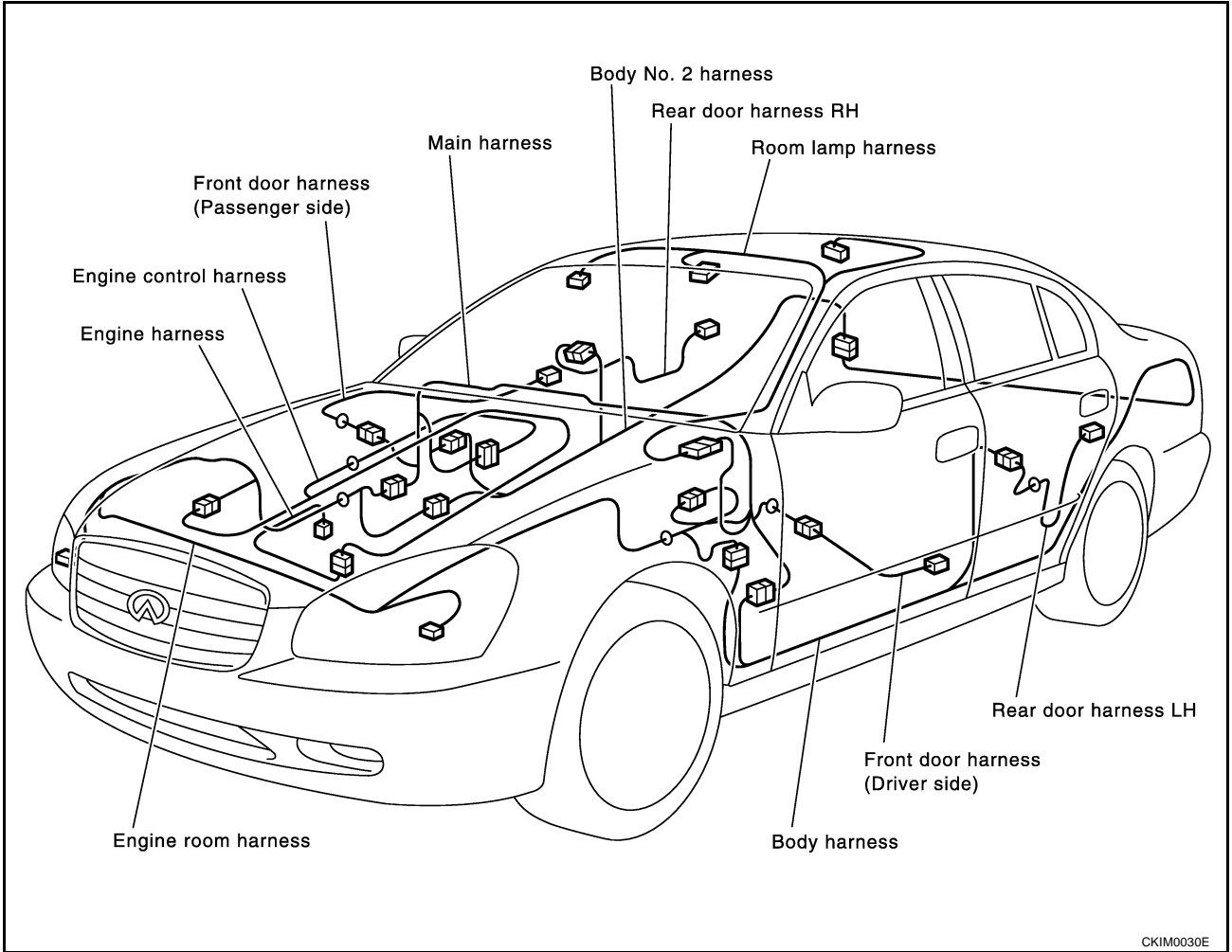

A

B

C

D

E

F

G

H

I

J

PG

L

M

HARNESS

MAIN HARNESS

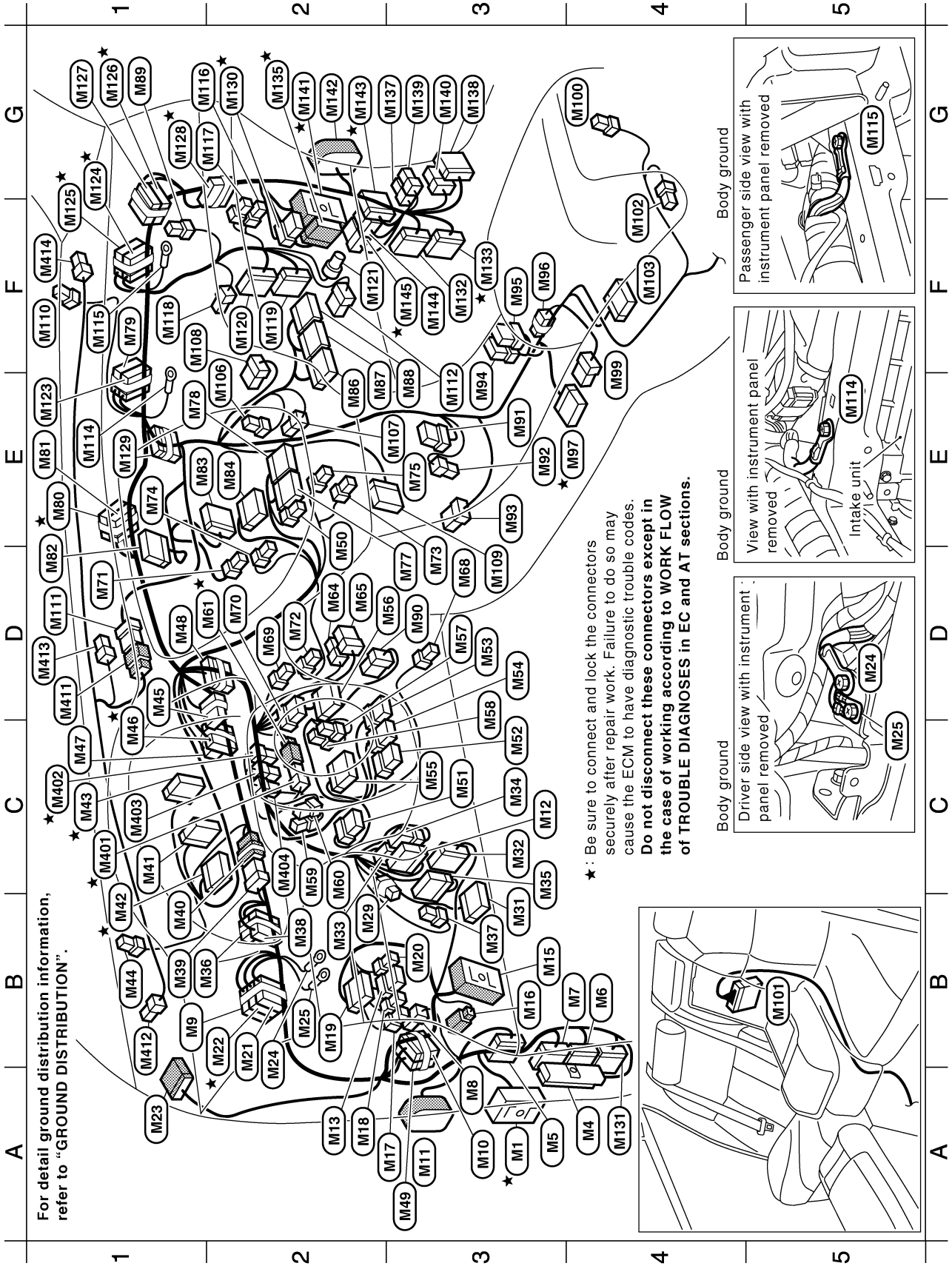

TKIM0111E

A3	★	M1	SMJ : Fuse block (J/B) No. 1	C1	M47	GY/20 : Joint connector-8
A4		M4	SMJ : BCM (Body control module)	D1	M48	B/20 : Joint connector-9
A3		M5	SMJ : To B5	A3	M49	OR/20 : Joint connector-10
B4		M6	GY/24 : To B6	E2	M50	GY/3 : AV control unit (Without NAVI)
B4		M7	W/24 : To B7	C3	M51	GY/6 : ADP steering switch
A3		M8	B/1 : Parking brake switch	C3	M52	W/8 : Steering angle sensor
B1		M9	P/20 : Joint connector-1	D3	M53	GY/8 : Combination switch (Spiral cable)
A3		M10	B/20 : Joint connector-2	D3	M54	Y/6 : Combination switch (Spiral cable)
A3		M11	SMJ : To D1	C3	M55	W/12 : Combination switch (Lighting switch)
C3		M12	GY/10 : Shift lock control unit	D2	M56	GY/12 : Combination switch (Front wiper switch)
A2		M13	GY/6 : VDC off switch	D3	M57	W/3 : Tilt sensor
B3		M15	SMJ : To E209	D3	M58	W/2 : Tilt motor
B3		M16	Y/4 : To E209	C2	M59	W/3 : Telescopic sensor
A3		M17	W/3 : Illumination control switch	C2	M60	W/2 : Telescopic motor
A2		M18	W/4 : Headlamp aiming switch	D2	★	M61 W/4 : To M40J
B2		M19	W/10 : Door mirror remote control switch	D2	M64	W/4 : Key switch and key lock solenoid
B3		M20	GY/4 : Active damper suspension select switch	D2	M65	W/6 : NATS antenna amp.
B2		M21	GY/20 : Joint connector-3	D3	M68	W/2 : In-vehicle sensor
B2	★	M22	L/20 : Joint connector-4	D2	M69	GY/4 : Steering lock control unit
A1		M23	W/18 : To R3	D2	M70	B/5 : Ignition switch
B2		M24	— : Body ground	D1	M71	W/4 : Hazard switch
B2		M25	— : Body ground	D2	M72	W/2 : Ignition key hole illumination
B2		M29	W/2 : Low tire pressure warning check switch	D3	M73	BR/2 : Microphone
B3		M31	W/16 : Data link connector	E1	M74	W/3 : Warning chime
C3		M32	W/16 : NATS IMMU	E3	M75	W/4 : Clock
B2		M33	W/6 : Headlamp battery saver control unit	D3	M77	GY/24 : AV control unit
C3		M34	W/8 : Headlamp battery saver control unit	E1	M78	W/24 : AV control unit
C3		M35	BR/24 : ASCD control unit (Without ICC)	F1	M79	G/20 : Joint connector-11
B1		M36	W/2 : Diode	E1	★	M80 R/20 : Joint connector-12
B3		M37	W/3 : ICC warning chime (With ICC)			
B2		M38	P/20 : Joint connector-5			
B1		M39	W/8 : To M40			
B1		M40	W/8 : To M39			
C1		M41	BR/20 : Combination meter			
B1	★	M42	BR/24 : Combination meter			
C1	★	M43	W/24 : Combination meter			
B1		M44	B/2 : Sunload sensor			
D1		M45	W/6 : Joint connector-6			
C1	★	M46	B/20 : Joint connector-7			

★ : Be sure to connect and lock the connectors securely after repair work.
 Failure to do so may cause the ECM to have diagnostic trouble codes.
Do not disconnect these connectors except in the case of working according to WORK FLOW of TROUBLE DIAGNOSES in EC and AT sections.

A
B
C
D
E
F
G
H
I
J

PG

L
M

E1	(M81)	P/20 : Joint connector-13
D1	(M82)	GY/24 : Display
E1	(M83)	W/20 : Multifunction switch
E2	(M84)	W/16 : Low tire pressure warning control unit
E2	(M86)	W/12 : Audio unit
E2	(M87)	W/16 : Audio unit
E3	(M88)	W/12 : Audio unit
G1	(M89)	BR/2 : Antenna amp. (Via sub-harness)
D3	(M90)	W/6 : Cooling unit assembly
E3	(M91)	W/8 : Combination flasher unit
E3	(M92)	W/3 : Front cigarette lighter socket
E3	(M93)	B/6 : Rear vent door motor
E3	(M94)	W/6 : Heated seat switch (Driver side)
F3	(M95)	BR/6 : Heated seat switch (Passenger side)
F3	(M96)	W/4 : Handset (Option)
E4	★ (M97)	W/16 : A/T device
E4	(M99)	B/6 : Yaw rate/Side G sensor
G4	(M100)	B/2 : Front power socket
B5	(M101)	W/24 : To (E501)
F4	(M102)	W/2 : Console box lamp
F4	(M103)	Y/28 : Air bag diagnosis sensor unit
E2	(M106)	W/3 : Mode door motor (Passenger side)
E3	(M107)	W/3 : Air mix door motor (Passenger side)
F1	(M108)	W/8 : Power steering control unit
D3	(M109)	W/16 : CD auto changer
F1	(M110)	W/3 : Optical sensor
D1	(M111)	W/6 : To (M41)
E3	(M112)	W/6 : Blower motor
E1	(M114)	— : Body ground
F1	(M115)	— : Body ground
G1	(M116)	W/2 : Glove box lamp
G1	(M117)	W/2 : Trunk lid opener cancel switch
F1	(M118)	W/3 : Intake door motor
F2	(M119)	GY/20 : A/C auto amp.
F2	(M120)	GY/16 : A/C auto amp.
F2	(M121)	Y/4 : Front passenger air bag module
E1	(M123)	L/20 : Joint connector-14
G1	★ (M124)	B/20 : Joint connector-15
F1	★ (M125)	B/20 : Joint connector-16

G1	★ (M126)	B/20 : Joint connector-17
G1	(M127)	OR/20 : Joint connector-18
G1	(M128)	OR/20 : Joint connector-19
E1	(M129)	B/20 : Joint connector-20
G2	(M130)	W/6 : Joint connector-21
A4	(M131)	BR/24 : To (B31)
F3	(M132)	W/24 : To (E222)
F3	(M133)	W/12 : To (E223)
G2	★ (M135)	SMJ : To (F105)
G3	(M137)	W/3 : To (B207)
G3	(M138)	BR/24 : To (B208)
G3	(M139)	W/4 : To (B209)
G3	(M140)	GY/6 : To (B210)
G2	★ (M141)	SMJ : To (B211)
G2	(M142)	SMJ : To (D31)
G2	★ (M143)	W/10 : Fuse block (J/B) No. 2
F3	(M144)	W/8 : Fuse block (J/B) No. 2
F3	★ (M145)	W/8 : Fuse block (J/B) No. 2

Main sub-harness-1

C1	★ (M401)	W/4 : To (M61)
C1	★ (M402)	B/2 : Stop lamp switch
C1	(M403)	BR/2 : ASCD brake switch (Without ICC)
C2	(M404)	BR/2 : ICC brake switch (With ICC)

Main sub-harness-2

D1	(M411)	W/6 : To (M111)
B1	(M412)	BR/2 : Instrument speaker LH
D1	(M413)	BR/2 : Instrument speaker CENTER
F1	(M414)	BR/2 : Instrument speaker RH

Diode (M36)

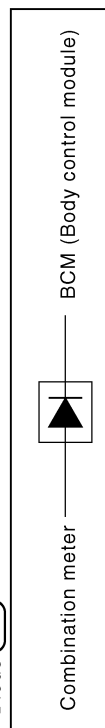

★ : Be sure to connect and lock the connectors securely after repair work.
 Failure to do so may cause the ECM to have diagnostic trouble codes.
Do not disconnect these connectors except in the case of working according to WORK FLOW of TROUBLE DIAGNOSES in EC and AT sections.

HARNESS

ENGINE ROOM HARNESS

Engine Compartment

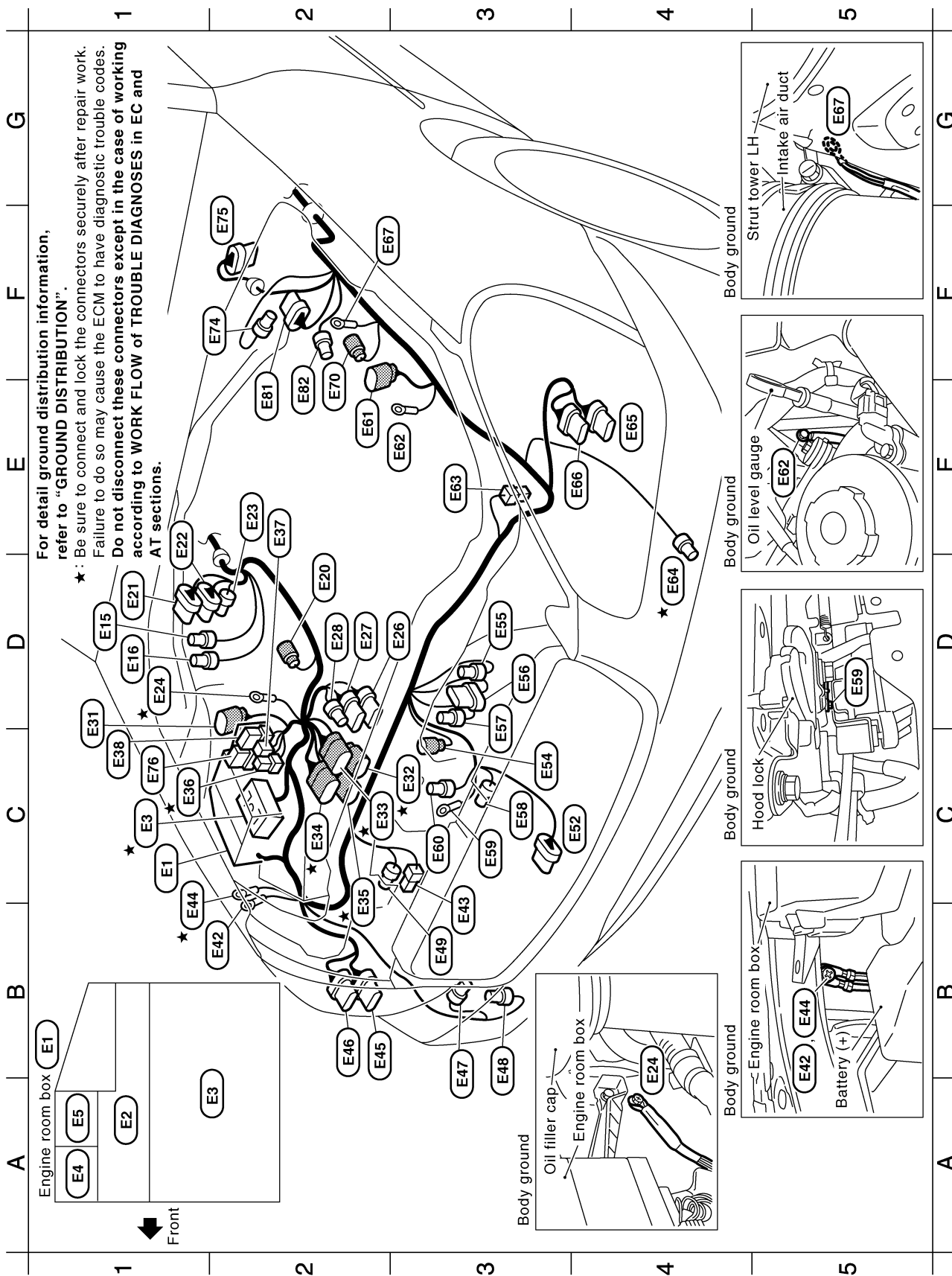

A
B
C
D
E
F
G
H
I
J
K
L
M
N
O
P
Q
R
S
T
U
V
W
X
Y
Z

PG

C1	(E1)	—	: Engine room box
A1	(E2)	—	: Fuse, fusible link and relay box
C1	(E3)	SMJ	: Fuse, fusible link and relay block (J/B)
A1	(E4)	B/5	: Front wiper relay
A1	(E5)	L/4	: Headlamp relay-2
D1	(E15)	SB/4	: ASCD pump (With ICC)
D1	(E16)	SB/4	: ASCD pump (Without ICC)
D2	(E20)	GY/2	: Front wheel sensor RH
D1	(E21)	DGY/8	: VDC actuator
D1	(E22)	SB/8	: VDC actuator
E2	(E23)	B/2	: VDC actuator
D2	(E24)	—	: Body ground
D3	(E26)	SB/8	: Daytime light control unit
D2	(E27)	SB/6	: Daytime light control unit
D2	(E28)	SB/4	: Daytime light control unit
D1	(E31)	GY/6	: Front shock absorber actuator RH
C3	(E32)	SB/8	To (F32)
C2	(E33)	GY/10	To (F33)
C2	(E34)	G/10	To (F34)
C2	(E35)	GY/9	To (E305)
C1	(E36)	L/4	: A/T pv ign relay
E2	(E37)	—	: Fuse block
C1	(E38)	GY/6	: ICC brake hold relay (With ICC)
B2	(E42)	—	: Body ground
C3	(E43)	B/1	: Horn low
B2	(E44)	—	: Body ground
B2	(E45)	DGY/8	: Front combination lamp RH
B2	(E46)	SB/8	: Front combination lamp RH
B3	(E47)	BR/2	: Washer level switch
B3	(E48)	GY/2	: Front washer motor
B3	(E49)	B/3	: Refrigerant pressure sensor
C3	(E52)	GY/6	: ICC sensor (With ICC)
C3	(E54)	GY/2	: Hood switch
D3	(E55)	GY/2	: VDC relay box
D3	(E56)	DGY/8	: VDC relay box
D3	(E57)	B/2	: VDC relay box
C3	(E58)	B/2	: Ambient sensor
C3	(E59)	—	: Body ground

C3	(E60)	Y/2	: Crash zone sensor
E2	(E61)	GY/6	: Front shock absorber actuator LH
E3	(E62)	—	: Body ground
E3	(E63)	B/1	: Horn high
E4	(E64)	GY/2	: Radiator coolant temperature sensor
E4	(E65)	DGY/8	: Front combination lamp LH
E4	(E66)	SB/8	: Front combination lamp LH
F2	(E67)	—	: Body ground
F2	(E70)	GY/2	: Front wheel sensor LH
F2	(E74)	GY/2	: Brake fluid level switch
F2	(E75)	SB/6	: Front wiper motor
C1	(E76)	BR/6	: Climate controlled seat relay
E2	(E81)	GY/6	: Brake booster
E2	(E82)	B/3	: Brake pressure sensor

} (For Canada)

★ : Be sure to connect and lock the connectors securely after repair work.
 Failure to do so may cause the ECM to have diagnostic trouble codes.
Do not disconnect these connectors except in the case of working according to WORK FLOW of TROUBLE DIAGNOSES in EC and AT sections.

HARNESS

Passenger Compartment

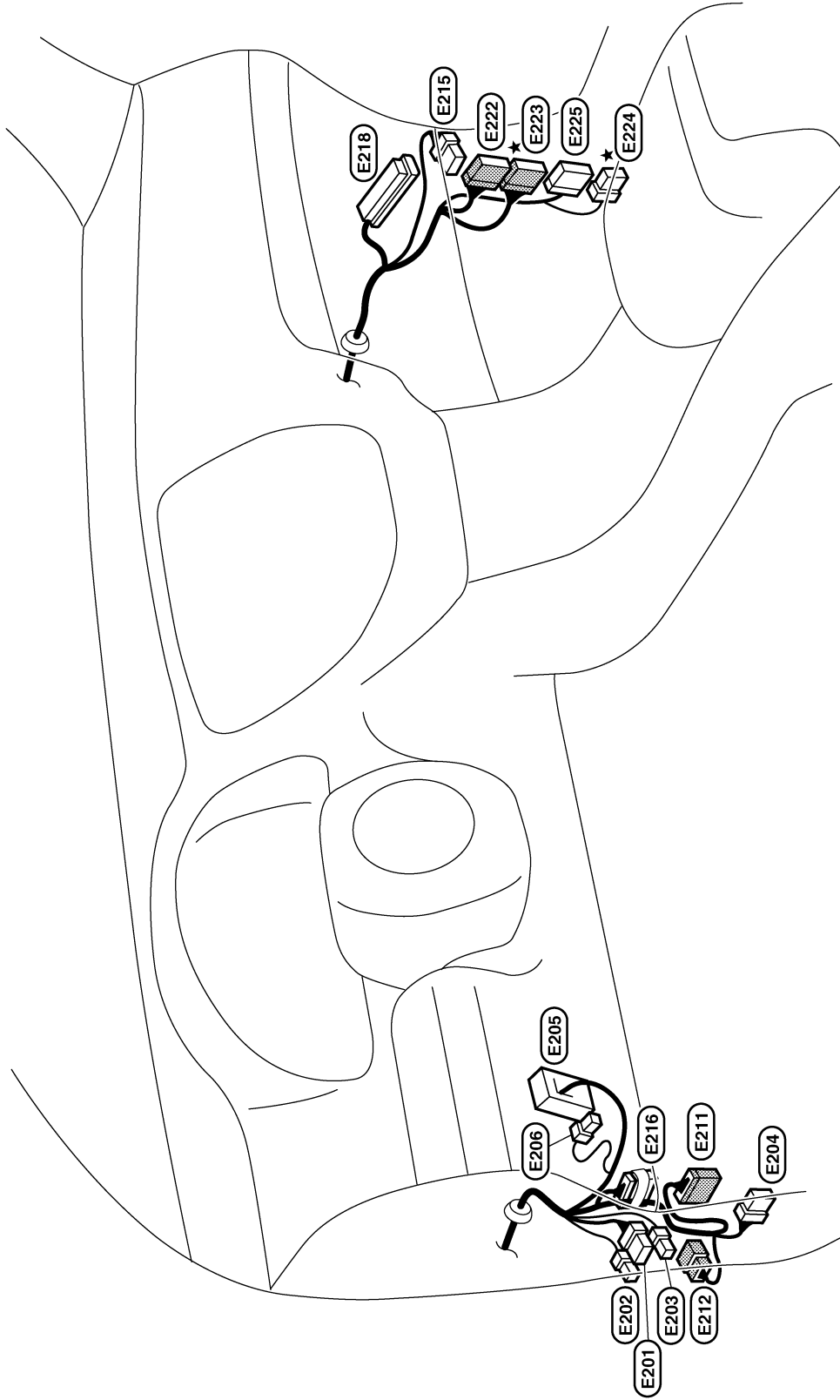

- E201** : Fuse block (J/B) No. 1
- E202** : Fuse block (J/B) No. 1
- E203** : Fuse block (J/B) No. 1
- E204** : BCM (Body control module)
- E205** : To **M15**
- E206** : To **M16**
- E211** : To **B11**
- E212** : To **B12** (With active damper suspension)
- E219** : Fuse block (J/B) No. 2

- E216** : Joint connector-25
- E218** : VDC/TCS/ABS control unit
- E222** : W/24 : To **M132**
- E223** : W/12 : To **M133**
- E224** : BR/6 : To **G204**
- E225** : W/20 : To **G205** (With ICC)

★ : Be sure to connect and lock the connectors securely after repair work. Failure to do so may cause the ECM to have diagnostic trouble codes. Do not disconnect these connectors except in the case of working according to **WORK FLOW** of **TROUBLE DIAGNOSES** in **EC** and **AT** sections.

A
B
C
D
E
F
G
H
I
J
L
M
PG

HARNESS

ENGINE HARNESS

- (E301) - : Battery (+)
- (E302) - : Fuse, fusible link and relay box and fuse, fusible link and relay block (J/B)
- (E303) - : Battery (+)
- ★ (E305) GY/9 : To (E35)
- (E307) - : Body ground
- ★ (E308) B/3 : Power steering pressure sensor
- (E309) - : Alternator
- (E310) GY/2 : Alternator
- (E311) - : Alternator
- (E312) GY/1 : Starter motor
- (E313) - : Starter motor
- ★ (E315) GY/10 : To (F5)
- ★ (E317) B/3 : Crankshaft position sensor (POS)
- ★ (E318) L/4 : Heated oxygen sensor 2 (Bank 2)
- ★ (E319) G/4 : Heated oxygen sensor 2 (Bank 1)

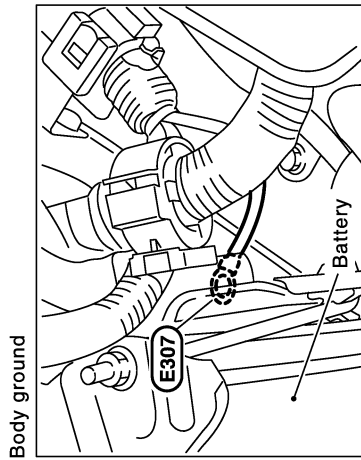
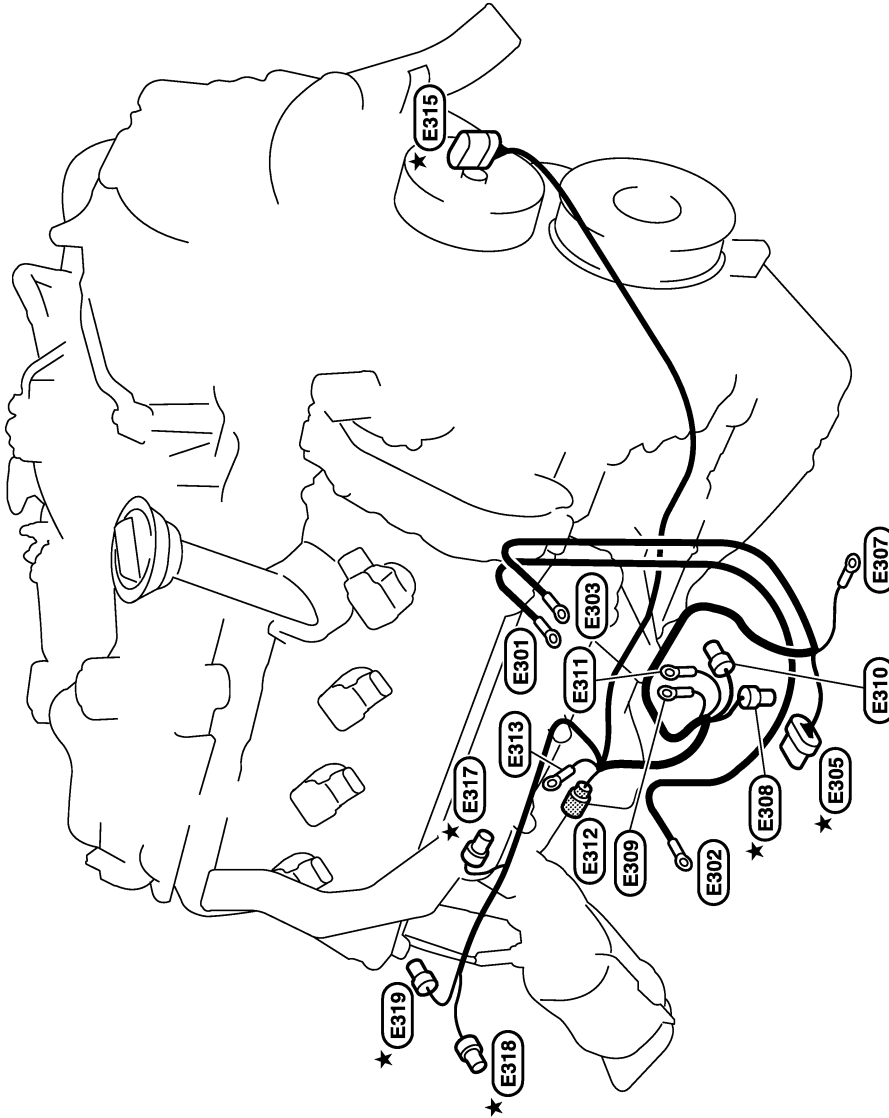

For detail ground distribution information, refer to "GROUND DISTRIBUTION".

★ : Be sure to connect and lock the connectors securely after repair work. Failure to do so may cause the ECM to have diagnostic trouble codes. Do not disconnect these connectors except in the case of working according to WORK FLOW of TROUBLE DIAGNOSES in EC and AT sections.

Engine control harness

D3	(F1)	GY/1 : Oil pressure switch
D3	(F2)	B/1 : Compressor (Magnet clutch)
E3	(F3)	BR/2 : Power steering solenoid valve
E3	(F4)	B/3 : Camshaft position sensor (PHASE)
E4	(F5)	GY/10 : To (E315)
D4	(F6)	B/2 : Compressor (ECV solenoid valve)
F3	(F7)	GY/5 : Mass air flow sensor
F3	(F8)	- : Engine ground
F3	(F9)	- : Engine ground
D3	(F12)	B/3 : Intake valve timing control position sensor (Bank 1)
D3	(F13)	G/2 : Intake valve timing control solenoid valve (Bank 1)
D3	(F14)	GY/2 : Cooling fan speed control solenoid valve
F3	(F15)	GY/3 : Ignition coil (With power transistor) No. 1
F3	(F16)	GY/3 : Ignition coil (With power transistor) No. 3
F3	(F17)	GY/3 : Ignition coil (With power transistor) No. 5
F2	(F18)	GY/3 : Ignition coil (With power transistor) No. 7
E2	(F19)	G/6 : Electric throttle control actuator
F2	(F20)	L/6 : Electric throttle control actuator
F1	(F21)	G/6 : To (F201)
F2	(F22)	G/4 : Heated oxygen sensor 1 (Bank 1)
E1	(F23)	GY/2 : Condenser
F2	(F24)	SB/2 : To (F261)
E1	(F25)	L/2 : EVAP canister purge volume control solenoid valve
F1	(F26)	G/10 : A/T unit assembly
G1	(F27)	G/8 : A/T unit assembly
F1	(F28)	B/8 : A/T unit assembly
D2	(F29)	B/2 : VIAS control solenoid valve
C2	(F30)	B/3 : Intake valve timing control position sensor (Bank 2)
C2	(F31)	G/2 : Intake valve timing control solenoid valve (Bank 2)
C2	(F32)	SB/8 : To (E32)
C2	(F33)	GY/10 : To (E33)
C2	(F34)	G/10 : To (E34)
D2	(F35)	GY/3 : Ignition coil (With power transistor) No. 2
C2	(F36)	GY/3 : Ignition coil (With power transistor) No. 4
D2	(F37)	GY/3 : Ignition coil (With power transistor) No. 6
D1	(F38)	GY/3 : Ignition coil (With power transistor) No. 8
E1	(F40)	DGY/4 : To (F241)

D1	(F41)	G/6 : To (F221)
E1	(F42)	G/4 : Heated oxygen sensor 1 (Bank 2)
A5	(F101)	SMJ : ECM
A5	(F102)	SMJ : ECM
B4	(F103)	W/24 : TCM (Transmission control module)
B5	(F104)	GY/24 : TCM (Transmission control module)
B4	(F105)	SMJ : To (M135)
B4	(F106)	P/20 : Joint connector-28
A4	(F107)	P/20 : Joint connector-29
B4	(F108)	L/12 : Joint connector-30

Engine control sub-harness-1

F1	(F201)	G/6 : To (F21)
D3	(F202)	GY/2 : Injector No. 1
E3	(F203)	GY/2 : Injector No. 3
E2	(F204)	GY/2 : Injector No. 5
E2	(F205)	GY/2 : Injector No. 7

Engine control sub-harness-2

D2	(F221)	G/6 : To (F41)
D3	(F222)	GY/2 : Injector No. 2
D2	(F223)	GY/2 : Injector No. 4
D3	(F224)	GY/2 : Injector No. 6
E2	(F225)	GY/2 : Injector No. 8

Engine control sub-harness-3

E1	(F241)	B/4 : To (F40)
E2	(F242)	GY/2 : Knock sensor (Bank 1)
E2	(F243)	GY/2 : Knock sensor (Bank 2)

Engine control sub-harness-4

F2	(F261)	SB/2 : To (F24)
F3	(F262)	GY/2 : Engine coolant temperature sensor

★ : Be sure to connect and lock the connectors securely after repair work. Failure to do so may cause the ECM to have diagnostic trouble codes. Do not disconnect these connectors except in the case of working according to WORK FLOW of TROUBLE DIAGNOSES in EC and AT sections.

HARNESS

BODY HARNESS AND REAR CONTROL HARNESS

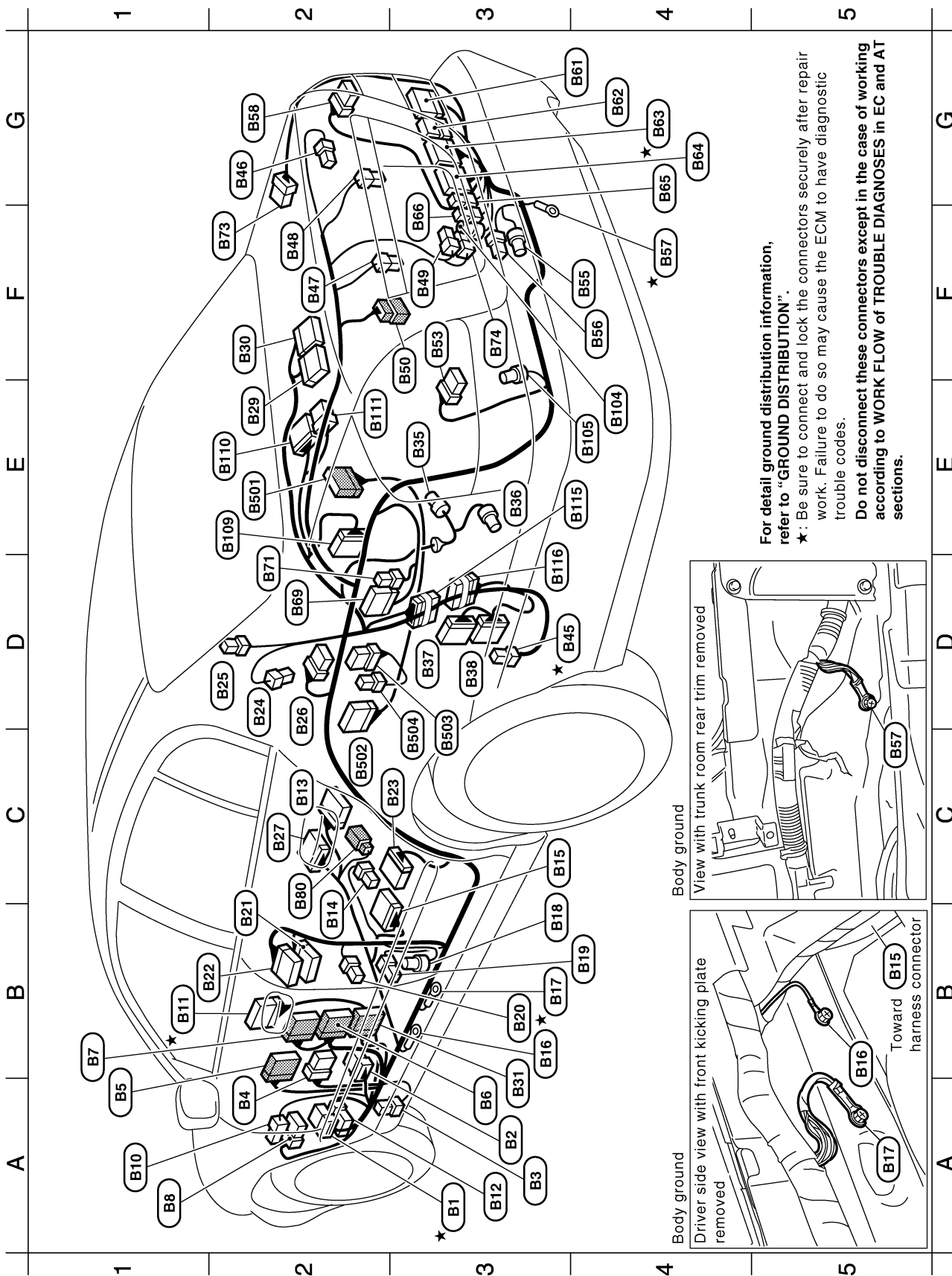

For detail ground distribution information, refer to "GROUND DISTRIBUTION".

★: Be sure to connect and lock the connectors securely after repair work. Failure to do so may cause the ECM to have diagnostic trouble codes.

Do not disconnect these connectors except in the case of working according to WORK FLOW of TROUBLE DIAGNOSES in EC and AT sections.

Body ground

View with trunk room rear trim removed

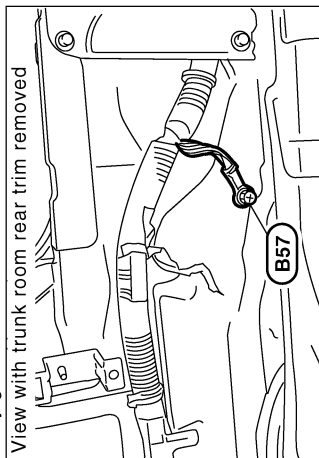

Body ground

Driver side view with front kicking plate removed

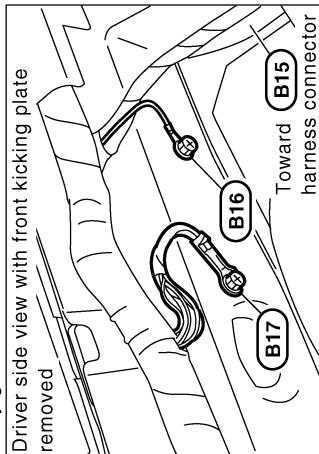

Body harness

A3	★ (B1)	W/8	: Fuse block (J/B) No. 1
A3	(B2)	W/6	: Fuse block (J/B) No. 1
A3	(B3)	W/3	: Front vertical G sensor
A2	(B4)	W/8	: BCM (Body control module)
A1	(B5)	SMJ	: To (M5)
A3	(B6)	GY/24	: To (M6)
B1	(B7)	W/24	: To (M7)
A1	(B8)	BR/6	: Rear window defogger and door mirror defogger relay
A1	(B10)	L/4	: Door mirror defogger relay
B1	★ (B11)	W/20	: To (E211)
A3	(B12)	BR/6	: To (E212)
C2	(B13)	Y/12	: Air bag diagnosis sensor unit
B2	(B14)	Y/2	: Front LH side air bag module
C3	(B15)	W/10	: Front power seat (Driver side) (Via sub-harness)
B3	(B16)	—	: Body ground
B3	★ (B17)	—	: Body ground
B3	(B18)	Y/2	: LH side air bag (Satellite) sensor
B4	(B19)	Y/2	: Front LH seat belt pre-tensioner
B3	(B20)	W/3	: Front door switch (Driver side)
B2	(B21)	W/15	: To (D51)
B1	(B22)	GY/15	: To (D51) (With rear power seat)
C3	(B23)	W/18	: Rear power seat LH (Via sub-harness)
D2	(B24)	Y/2	: LH side curtain air bag module
D2	(B25)	W/1	: Condenser (Rear window defogger)
D2	(B26)	W/6	: Rear shock absorber actuator LH
C2	(B27)	W/16	: Option connector-2 for voice activated system
E2	(B29)	GY/24	: AV and NAVI control unit
F2	(B30)	W/24	: AV and NAVI control unit } (With NAVI)
A3	(B31)	BR/24	: To (M131)
E3	(B35)	SB/4	: Rear wheel sensor
E3	(B36)	GY/2	: Dual mode muffler actuator
D3	(B37)	W/24	: Active damper suspension control unit
D3	(B38)	GY/24	: Active damper suspension control unit
D4	★ (B45)	W/2	: Dropping resistor
G2	(B46)	W/3	: Trunk lid key cylinder switch (Unlock switch)
F2	(B47)	BR/2	: License lamp LH
F2	(B48)	BR/2	: License lamp RH
F3	(B49)	B/2	: Trunk lid opener actuator
F3	(B50)	W/6	: Rear view camera

F3	(B53)	W/6	: Rear combination lamp LH
F4	(B55)	GY/2	: Trunk lid striker switch
F4	(B56)	W/4	: Trunk closure control unit
F4	★ (B57)	—	: Body ground
G2	(B58)	W/6	: Rear combination lamp RH
G4	(B61)	W/12	: To (E261)
G4	(B62)	BR/8	: To (E262)
G4	★ (B63)	W/10	: To (E263)
G4	(B64)	W/16	: To (E264)
G4	(B65)	W/2	: To (E265) (With ICC)
F3	(B66)	W/3	: To (E266)
D2	(B69)	W/22	: Voice activated control module
D2	(B71)	GY/3	: Voice activated control module
F2	(B73)	W/6	: Dual mode muffler control unit
F3	(B74)	W/2	: Trunk lid lock switch (Without auto trunk)
C2	(B80)	W/4	: To (B280) (With climate controlled seat)
E4	(B104)	BR/2	: Auto trunk buzzer-1
E4	(B105)	BR/2	: Auto trunk buzzer-2
E2	(B109)	W/10	: Auto trunk motor
E2	(B110)	W/16	: Auto trunk control unit
E2	(B111)	W/6	: Auto trunk control unit
E4	(B115)	W/16	: Jumping connector (For Satellite radio receiver)
D3	(B116)	W/16	: Jumping connector (For Satellite radio receiver)

Rear control harness

E2	(B501)	W/24	: To (M10)
C2	(B502)	W/12	: Rear control switch
C3	(B503)	W/6	: Rear sunshade rear switch
C3	(B504)	W/4	: Auto return cancel switch

★ : Be sure to connect and lock the connectors securely after repair work.
 Failure to do so may cause the ECM to have diagnostic trouble codes.
Do not disconnect these connectors except in the case of working according to WORK FLOW of TROUBLE DIAGNOSES in EC and AT sections.

HARNESS

BODY NO. 2 HARNESS

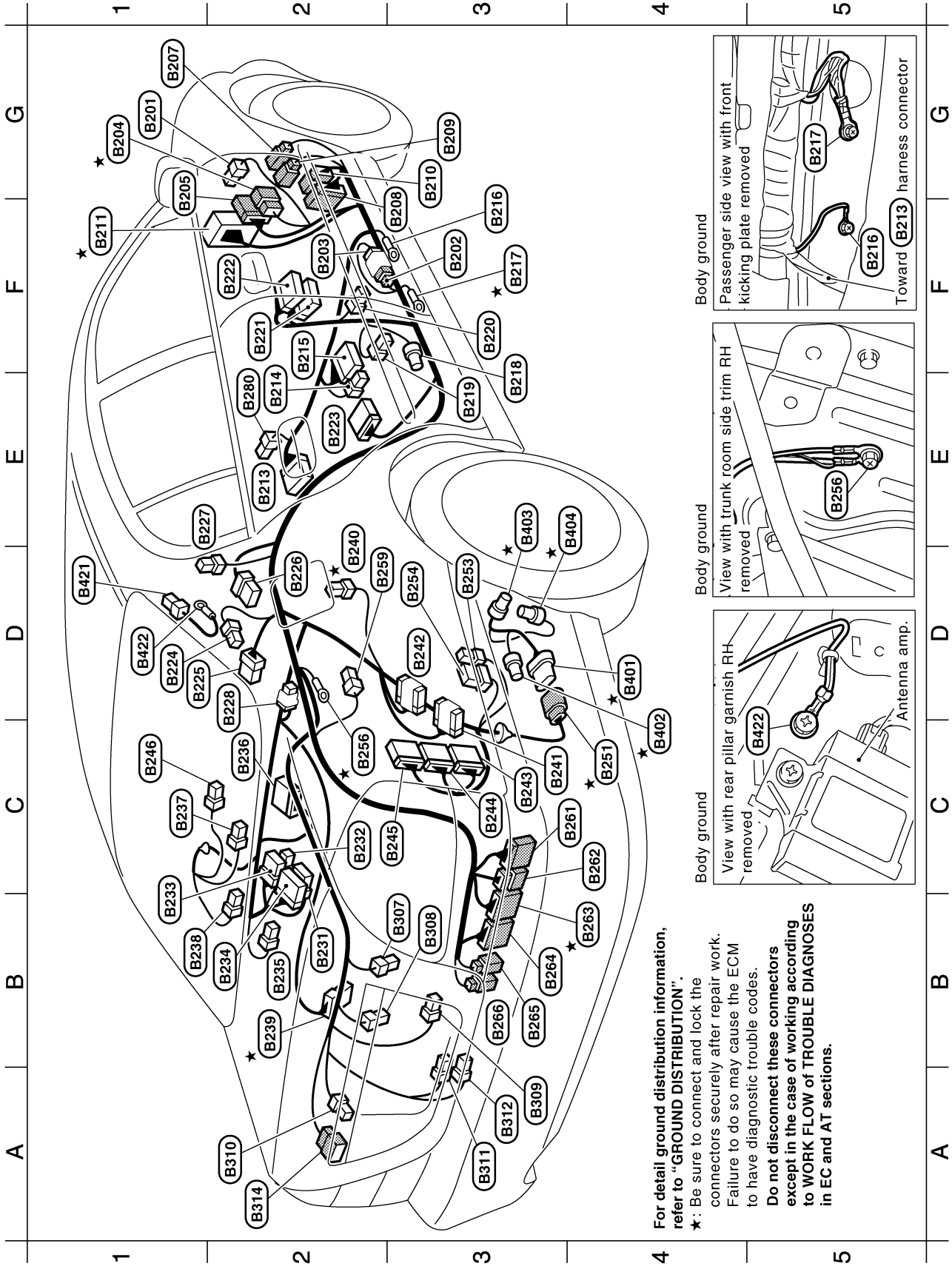

For detail ground distribution information, refer to "GROUND DISTRIBUTION".

★: Be sure to connect and lock the connectors securely after repair work. Failure to do so may cause the ECM to have diagnostic trouble codes.

Do not disconnect these connectors except in the case of working according to WORK FLOW of TROUBLE DIAGNOSES in EC and AT sections.

Body No. 2 harness

G1	(B201)	W/4 : Fuse block (J/B) No. 2
F3	(B202)	W/3 : To (B203)
F2	(B203)	W/3 : To (B202)
G1	(B204)	BR/6 : To (E224)
G1	(B205)	W/20 : To (E225) (With ICC)
G1	(B207)	W/3 : To (M137)
F3	(B208)	BR/24 : To (M138)
G3	(B209)	W/4 : To (M139)
F3	(B210)	GY/6 : To (M140)
F1	(B211)	SMJ : To (M141)
E2	(B213)	Y/12 : Air bag diagnosis sensor unit
E2	(B214)	Y/2 : Front RH side air bag module
F2	(B215)	W/10 : Front power seat (Passenger side) (Via sub-harness)
F3	(B216)	— : Body ground
F3	(B217)	— : Body ground
E3	(B218)	Y/2 : RH side air bag (Satellite) sensor
E3	(B219)	Y/2 : Front RH seat belt pre-tensioner
F3	(B220)	W/3 : Front door switch (Passenger side)
F2	(B221)	W/15 : To (D71)
F2	(B222)	GY/15 : To (D71) (With rear power seat)
E2	(B223)	W/18 : Rear power seat RH (Via sub-harness)
D1	(B224)	Y/2 : RH side curtain air bag module
D1	(B225)	W/6 : Rear sunshade unit
D2	(B226)	W/6 : Rear shock absorber actuator RH
E1	(B227)	W/3 : Rear vertical G sensor
D2	(B228)	GY/2 : Condenser
B2	(B231)	B/6 : BOSE speaker amp.
C2	(B232)	W/4 : BOSE speaker amp.
B1	(B233)	LG/8 : BOSE speaker amp.
B2	(B234)	B/24 : BOSE speaker amp.
B2	(B235)	W/2 : Woofer
C2	(B236)	GY/24 : Rear view camera control unit
C1	(B237)	W/2 : High-mounted stop lamp
B1	(B238)	W/2 : Trunk room lamp
B2	(B239)	W/6 : Fuel level sensor unit and fuel pump
D2	(B240)	W/4 : Fuel pump control module (FPCM)
C3	(B241)	P/20 : Joint connector-36
D3	(B242)	OR/20 : Joint connector-37

C3	(B243)	W/24 : ICC unit	} (With ICC)
C3	(B244)	GY/24 : ICC unit	
C3	(B245)	G/24 : ICC unit	
C1	(B246)	W/4 : Remote keyless entry receiver	
C4	(B251)	SB/8 : To (B401)	
D3	(B253)	L/4 : Rear control cancel relay	
D3	(B254)	BR/6 : Rear sunshade cancel relay	
C2	(B255)	— : Body ground	
D2	(B259)	W/4 : Fuel lid opener actuator	
C4	(B261)	W/12 : To (B61)	
C4	(B262)	BR/8 : To (B62)	
B4	(B263)	W/10 : To (B63)	
B3	(B264)	W/16 : To (B64)	
B3	(B265)	W/2 : To (B65) (With ICC)	
B3	(B266)	W/3 : To (B66)	
E2	(B280)	W/4 : To (B80) (With climate controlled seat)	
B3	(B307)	W/3 : Trunk lid key cylinder switch (Unloch switch) } (With auto trunk)	
B3	(B308)	BR/2 : License lamp RH	
A3	(B309)	W/2 : Trunk lid close switch	
A2	(B310)	BR/2 : License lamp LH	
A3	(B311)	B/2 : Trunk lid opener actuator	} (With auto trunk)
A3	(B312)	W/2 : Trunk lid lock switch	
A2	(B314)	W/6 : Rear view camera	

Body No. 2 sub-harness-1

D4	(B401)	SB/8 : To (B251)
C4	(B402)	B/2 : EVAP canister vent control valve
E3	(B403)	BR/3 : EVAP control system pressure sensor
E4	(B404)	G/2 : Vacuum cut valve bypass valve

Body No. 2 sub-harness-2

D1	(B421)	B/1 : Rear window defogger (—)
D1	(B422)	— : Body ground

★ : Be sure to connect and lock the connectors securely after repair work. Failure to do so may cause the ECM to have diagnostic trouble codes. **Do not disconnect these connectors except in the case of working according to WORK FLOW of TROUBLE DIAGNOSES in EC and AT sections.**

HARNESS

ROOM LAMP HARNESS

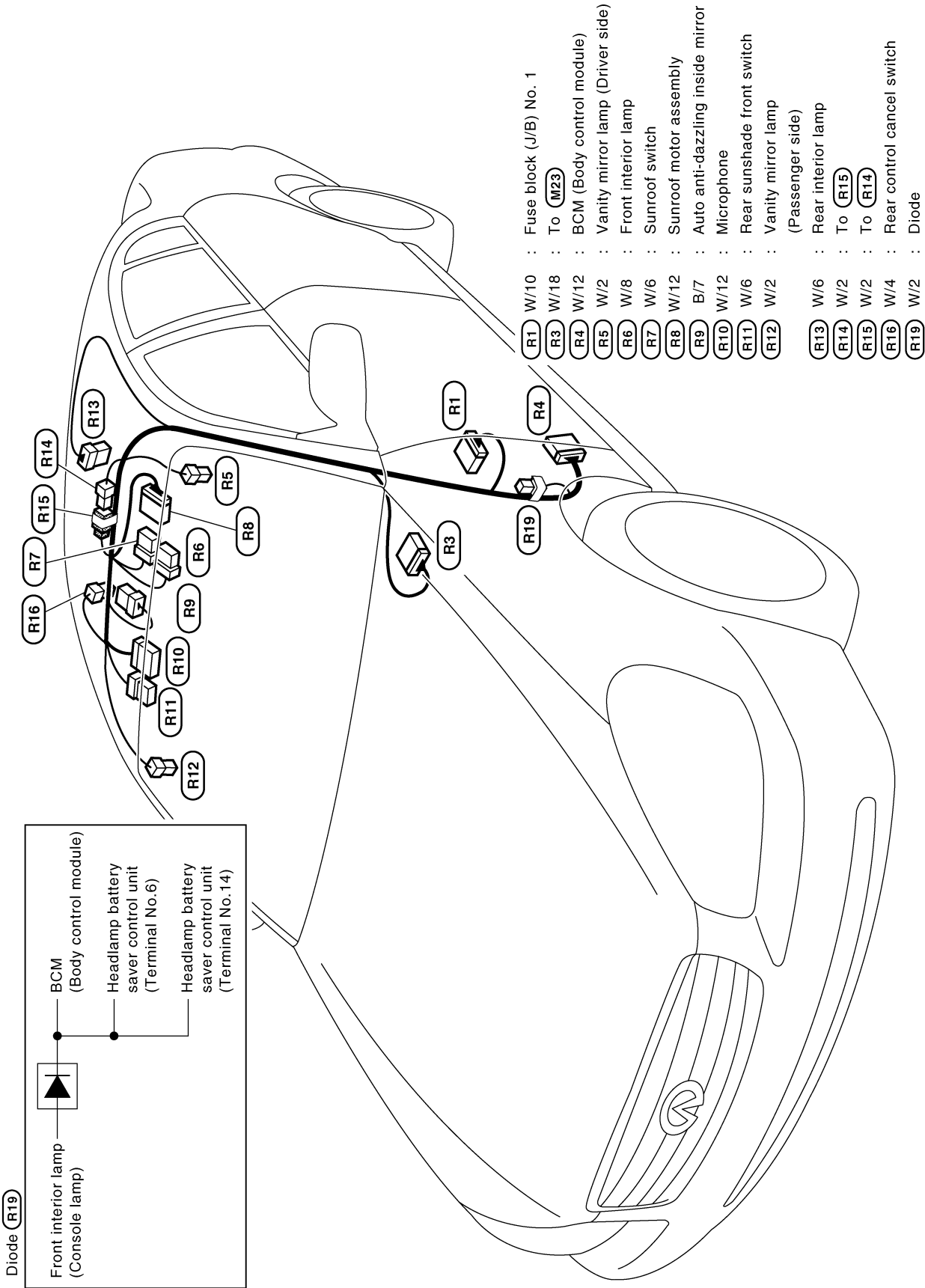

A
B
C
D
E
F
G
H
I
J
PG
L
M

HARNESS

FRONT DOOR HARNESS

LH Side

- (D1) SMJ : To (M11)
- (D2) BR/16 : Door mirror (Driver side)
- (D3) W/8 : Seat memory switch
- (D4) GY/2 : Power window main switch illumination
- (D5) W/10 : Driver side door mirror control unit (LCU03)
- (D6) W/2 : Front door speaker LH
- (D7) W/6 : Front power window motor (Driver side)
- (D8) W/18 : Driver door control unit (LCU01)
- (D9) W/3 : Trunk lid and fuel lid opener switch
- (D10) W/2 : Front step lamp (Driver side)
- (D11) SB/4 : Front door lock actuator (Driver side)
- (D12) BR/3 : Front door key cylinder switch (Driver side)
- (D14) P/20 : Joint connector-41

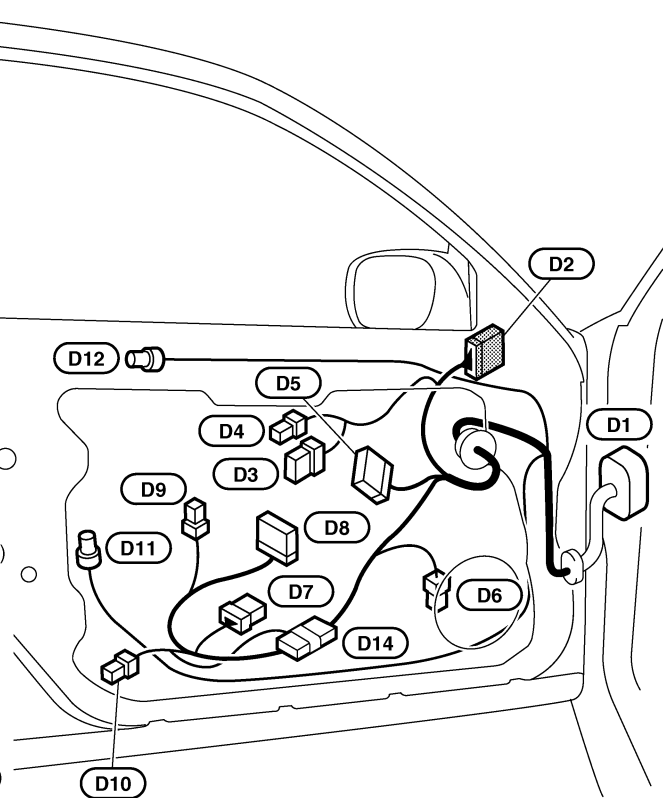

TKIM0137E

RH Side

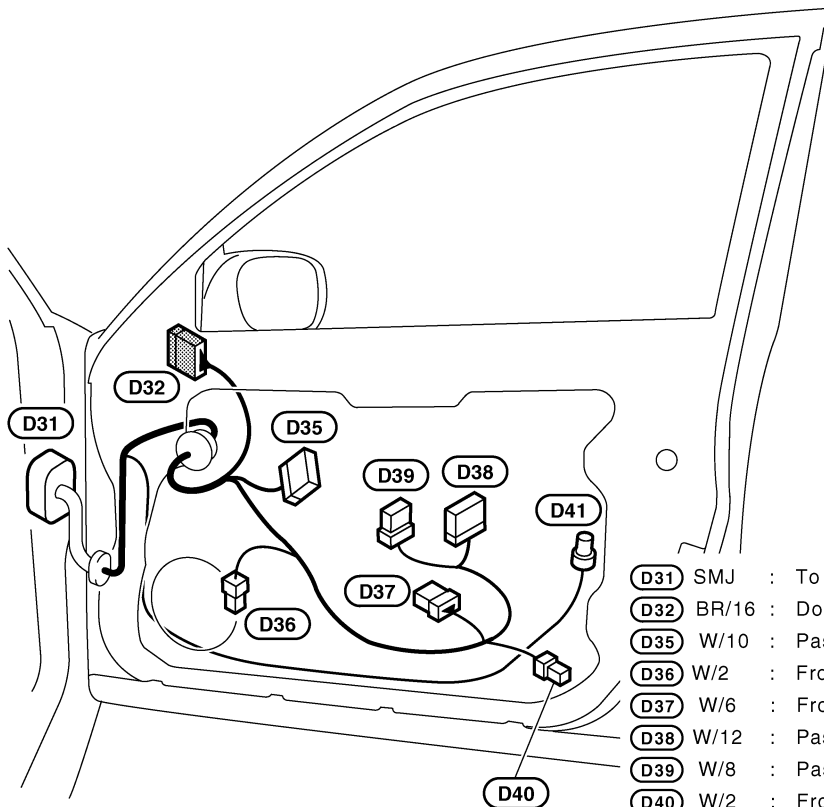

- (D31) SMJ : To (M142)
- (D32) BR/16 : Door mirror (Passenger side)
- (D35) W/10 : Passenger side door mirror control unit (LCU04)
- (D36) W/2 : Front door speaker RH
- (D37) W/6 : Front power window motor (Passenger side)
- (D38) W/12 : Passenger door control unit
- (D39) W/8 : Passenger door control unit
- (D40) W/2 : Front step lamp (Passenger side)
- (D41) SB/4 : Front door lock actuator (Passenger side)

TKIM0138E

HARNESS

REAR DOOR HARNESS

LH Side

- D51** W/30 : To **B21**, **B22**
- D54** W/3 : Rear ashtray LH illumination
- D55** W/12 : Rear power seat switch LH
- D56** BR/2 : Rear door speaker LH
- D57** GY/6 : Rear power window motor LH
- D58** W/12 : Rear LH door control unit
- D59** W/8 : Rear LH door control unit
- D60** W/2 : Rear step lamp LH
- D61** SB/4 : Rear door lock actuator LH
- D62** B/2 : Door lock assembly rear LH (Door switch)

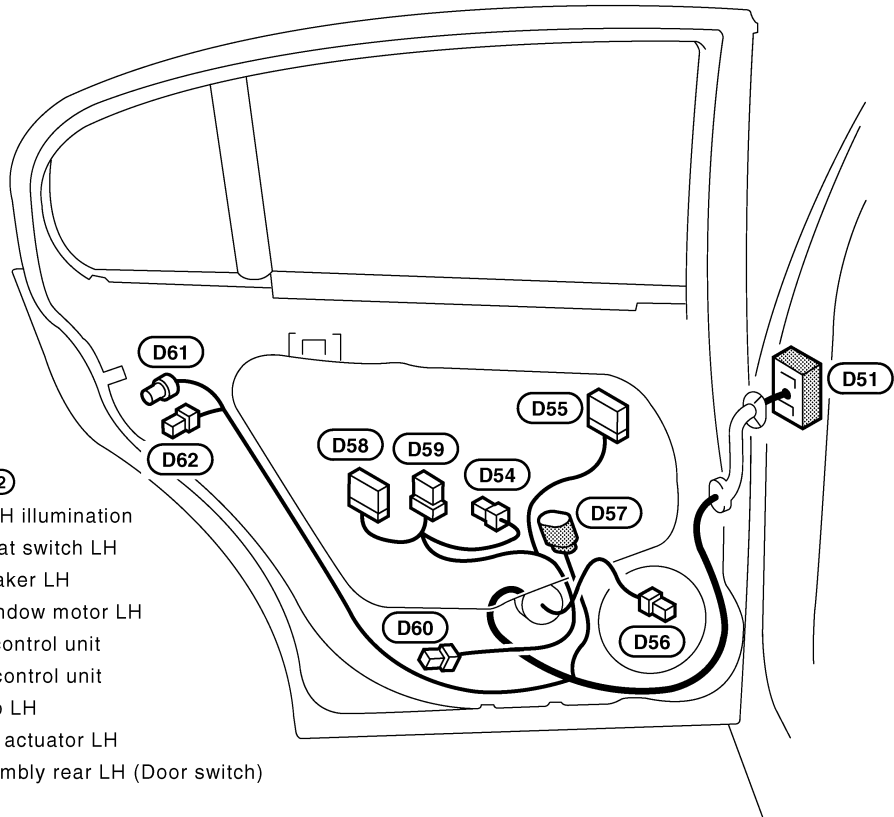

TKIM0139E

RH Side

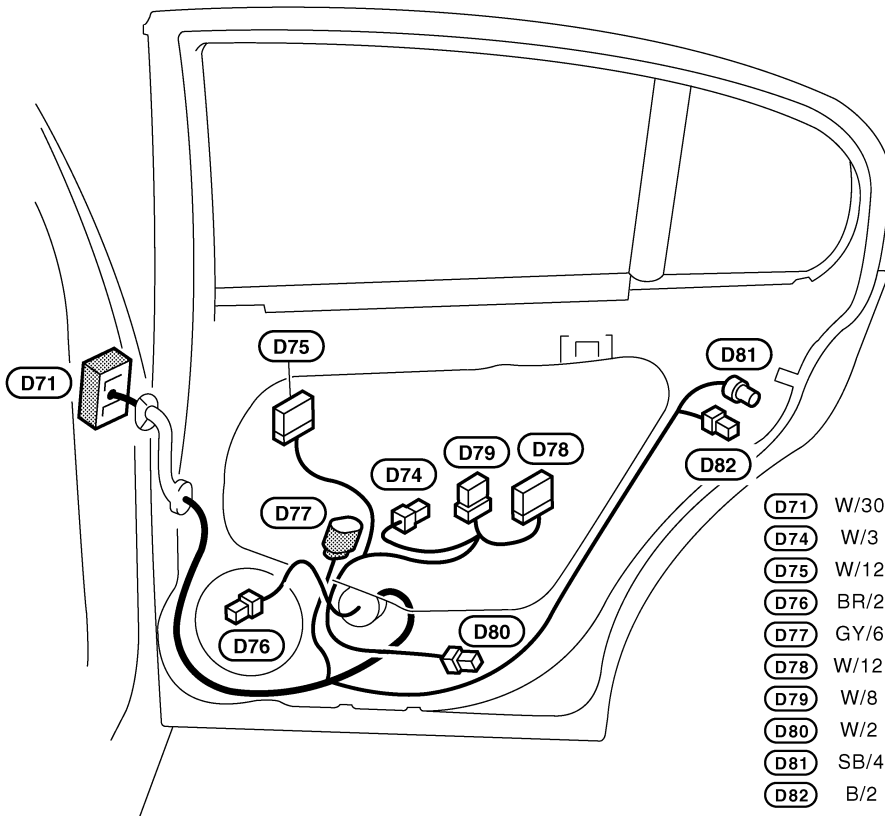

- D71** W/30 : To **B221**, **B222**
- D74** W/3 : Rear ashtray RH illumination
- D75** W/12 : Rear power seat switch RH
- D76** BR/2 : Rear door speaker RH
- D77** GY/6 : Rear power window motor RH
- D78** W/12 : Rear RH door control unit
- D79** W/8 : Rear RH door control unit
- D80** W/2 : Rear step lamp RH
- D81** SB/4 : Rear door lock actuator RH
- D82** B/2 : Door lock assembly rear RH (Door switch)

TKIM0140E

A
B
C
D
E
F
G
H
I
J
PG
L
M

HARNESS

Wiring Diagram Codes (Cell Codes)

EKS000DT

Use the chart below to find out what each wiring diagram code stands for.

Refer to the wiring diagram code in the alphabetical index to find the location (page number) of each wiring diagram.

Code	Section	Wiring Diagram Name
A/C	ATC	Air Conditioner
A/TRNK	BL	Auto Trunk System
ACTIVE	SCS	Active Damper Suspension System
APPS1	EC	Accelerator Pedal Position Sensor (Sensor1)
APPS2	EC	Accelerator Pedal Position Sensor (Sensor2)
APPS3	EC	Accelerator Pedal Position Sensor
ASCD	ACS	Automatic Speed Control Device
AT/IND	DI	A/T Indicator
AUDIO	AV	Audio
AUT/DP	SE	Automatic Drive Positioner - IVMS
BACK/L	LT	Back-up Lamp
BRK/SW	EC	Brake Switch
BYPS/V	EC	Vacuum Cut Valve Bypass Valve
CAN	AT	CAN Communication Line
CAN	EC	CAN Communication Line
CAN	LAN	CAN System
C/SEAT	SE	Climate controlled seat
CD/CHG	AV	CD Auto Changer
CHARGE	SC	Charging System
CHIME	DI	Warning Chime
CIGAR	WW	Cigarette Lighter
CLOCK	DI	Clock
COMM	AV	Audio Visual Communication Line
COMM	DI	Audio Visual Communication Line
COMM	LAN	IVMS - Communication Check, Power Supply & Ground
COMPAS	DI	Compass
COOL/V	EC	Cooling Fan Speed Control Solenoid Valve
D/C	AT	Direct Clutch Solenoid Valve
D/CF	AT	Direct Clutch Solenoid Valve Function
D/LOCK	BL	Power Door Lock - IVMS
DEF	GW	Rear Window Defogger
DLC	EC	Data Link Connectors
DTRL	LT	Headlamp - With Daytime Light System
E/BRE	AT	Low Coast Brake Solenoid Valve
ECM/PW	EC	ECM Power Supply Back - up
ECTS	EC	Engine Coolant Temperature Sensor
EPS	STC	Electronic Controlled Power Steering System
ETC1	EC	Electrical Throttle Function
ETC2	EC	Electrical Throttle Control Motor Relay
ETC3	EC	Electrical Throttle Control Motor
F/PUMP	EC	Fuel Pump

HARNESS

Code	Section	Wiring Diagram Name
FR/B	AT	Front Brake Solenoid Valve
FR/BF	AT	Front Brake Solenoid Valve Function
FLS1	EC	Fuel Level Sensor Function (SLOSH)
FLS2	EC	Fuel Level Sensor Circuit
FLS3	EC	Fuel Level Sensor Circuit (Ground Signal)
FPCM	EC	Fuel Pump Control Module
FPSW1	AT	Pressure Switch 1 (FR/B)
FPSW3	AT	Pressure Switch 3 (I/C)
FPSW5	AT	Pressure Switch 5 (D/C)
FPSW6	AT	Pressure Switch 6 (HLR/C)
FTS	AT	A/T Fluid Temperature Sensor
FTTS	EC	Fuel tank Temperature Sensor
FUELB1	EC	Fuel Injection System Function (Bank 1)
FUELB2	EC	Fuel Injection System Function (Bank 2)
H/AIM	LT	Headlamp Aiming Control System
H/LAMP	LT	Headlamp
HLR/C	AT	High and Low Reverse Clutch Solenoid Valve
HLR/CF	AT	High and Low Reverse Clutch Solenoid Valve Function
HORN	WW	Horn
HSEAT	SE	Heated Seat
I/C	AT	Input Clutch Solenoid Valve
I/CF	AT	Input Clutch Solenoid Valve Function
I/LOCK	AT	Solenoid Valve and Pressure Switch
I/MIRR	GW	Inside Mirror (Auto-anti dazzling mirror)
IATS	EC	Intake Air Temperature Sensor
ICC	ACS	Intelligent Cruise Control System
IGN/SG	EC	Ignition Signal
ILL	LT	Illumination
INF/D	DI	Information Display
INJECT	EC	Injector
INT/L	LT	Vanity Mirror and Trunk Room Lamps
IVCB1	EC	Intake Valve Timing Control Solenoid Valve Bank 1
IVCB2	EC	Intake Valve Timing Control Solenoid Valve Bank 2
IVCSB1	EC	Intake Valve Timing Control Position Sensor Bank 1
IVCSB2	EC	Intake Valve Timing Control Position Sensor Bank 2
IVTB1	EC	Intake Valve Timing Control System (Bank 1)
IVTB2	EC	Intake Valve Timing Control System (Bank 2)
KEYLES	BL	Remote Keyless Entry System-IVMS
KS	EC	Knock Sensor
LC/B	AT	Low Coast Break Solenoid Valve
LC/BF	AT	Low Coast Break Solenoid Valve Function
LOAD	EC	Load Signal
LPSV	AT	Line Pressure Solenoid Valve
MAFS	EC	Mass Air Flow Sensor

A

B

C

D

E

F

G

H

I

J

PG

L

M

HARNESS

Code	Section	Wiring Diagram Name
MAIN	EC	Main Power Supply and Ground Circuit
METER	DI	Speedometer, Tachometer, Temp., Oil and Fuel Gauges
MIL	EC	Malfunction Indicator Lamp
MIRR/L	LT	Door Mirror (Foot Well) Lamp
MIRROR	GW	Door Mirror
MMSW	AT	Manual Mode Switch
NATS	BL	IVIS (Infiniti Vehicle Immobilizer System - NATS)
NAVI	AV	Navigation System
NONDTC	AT	Non-detective Items
O2H1B1	EC	Heated Oxygen Sensor 1 Heater Bank 1
O2H1B2	EC	Heated Oxygen Sensor 1 Heater Bank 2
O2H2B1	EC	Rear Heated Oxygen Sensor 2 Heater Bank 1
O2H2B2	EC	Rear Heated Oxygen Sensor 2 Heater Bank 2
O2S1B1	EC	Heated Oxygen Sensor 1 Bank 1
O2S1B2	EC	Heated Oxygen Sensor 1 Bank 2
O2S2B1	EC	Rear Heated Oxygen Sensor 2 Bank 1
O2S2B2	EC	Rear Heated Oxygen Sensor 2 Bank 2
PGC/V	EC	EVAP Canister Purge Volume Control Solenoid Valve
PHASE	EC	Camshaft Position Sensor (PHASE)
PHONE	AV	Telephone
PNP/SW	EC	Park/Neutral Position Switch
PNP/SW	AT	Park/Neutral Position Switch
POS	EC	Crankshaft Position Sensor (CKPS) (POS)
POWER	AT	Transmission Control Module Power Supply
POWER	PG	Power Supply Routing
PRE/SE	EC	EVAP Control System Pressure Sensor
PS/SEN	EC	Power Steering Pressure Sensor
R/VIEW	DI	Rear View Camera Control System
RCTS	EC	Radiator Coolant Temperature Sensor
REMOTE	AV	Audio (Remote Control Switch)
ROOM/L	LT	Interior Room Lamp - IVMS
RP/SEN	EC	Refrigerant Pressure Sensor
S/SIG	EC	Start Signal
SEAT	SE	Power Seat
SEN/PW	EC	Sensor Power Supply
SHADE	EI	Rear Sunshade
SHIFT	AT	A/T Shift Lock System
SROOF	RF	Sunroof
SRS	SRS	Supplemental Restraint System
START	SC	Starting System
STEP/L	LT	Step Lamp - IVMS
STOP/L	LT	Stop Lamp
STSIG	AT	Start Signal
SW/ILL	GW	Power Window Switch Illumination - IVMS

HARNESS

Code	Section	Wiring Diagram Name	
T&FLID	BL	Trunk Lid and Fuel Lid Opener	A
T/CLOS	BL	Trunk Closure System	
T/WARN	WT	Low Tire Pressure Warning System	B
TAIL/L	LT	Parking, License and Tail Lamps	
TCCSIG	AT	A/T TCC Signal (Lock Up)	
TCV	AT	Torque Converter Clutch Solenoid Valve	C
TPS1	EC	Throttle Position Sensor (Sensor1)	
TPS2	EC	Throttle Position Sensor (Sensor2)	D
TPS3	EC	Throttle Position Sensor	
TRANSCV	BL	Homelink Universal Transceiver	
TRSA/T	AT	Turbine Revolution Sensor	E
TURN	LT	Turn Signal and Hazard Warning Lamps	
VDC	BRC	Vehicle Dynamics Control System	F
VEHSEC	BL	Vehicle Security System - IVMS	
VENT/V	EC	EVAP Canister Vent Control Valve	
VEXH	EX	Variable Exhaust Muffler Control System	G
VIAS/V	EC	Variable Air Induction Control System	
VOICE	DI	Voice Activated Control System	
VSSAT	AT	Vehicle Speed Sensor A/T (Revolution Sensor)	H
W/ANT	AV	Audio Antenna	
WARN	DI	Warning Lamps	I
WINDOW	GW	Power Window - IVMS	
WIPER	WW	Wiper and Washer	J

PG

L

M

ELECTRICAL UNITS LOCATION

ELECTRICAL UNITS LOCATION

PFP:25230

Electrical Units Location

EKS003SA

Use parts code, if applicable, and chassis number to find correct parts number in parts catalog. Parts codes are shown in illustration.

NOTICE:

Parts codes in illustration are those in effect at the time of the first service manual edition. Information might not be maintained in the timely manner. Always confirm correct parts code using appropriate parts catalog.

ELECTRICAL UNITS LOCATION

ENGINE COMPARTMENT

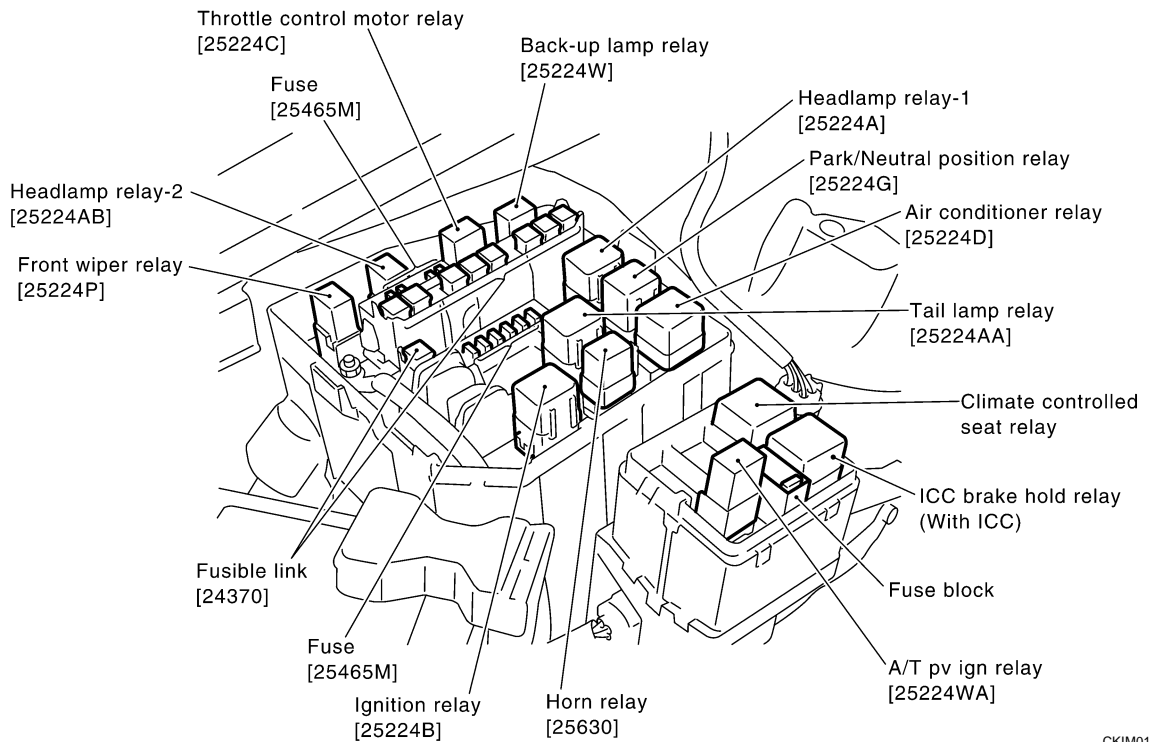
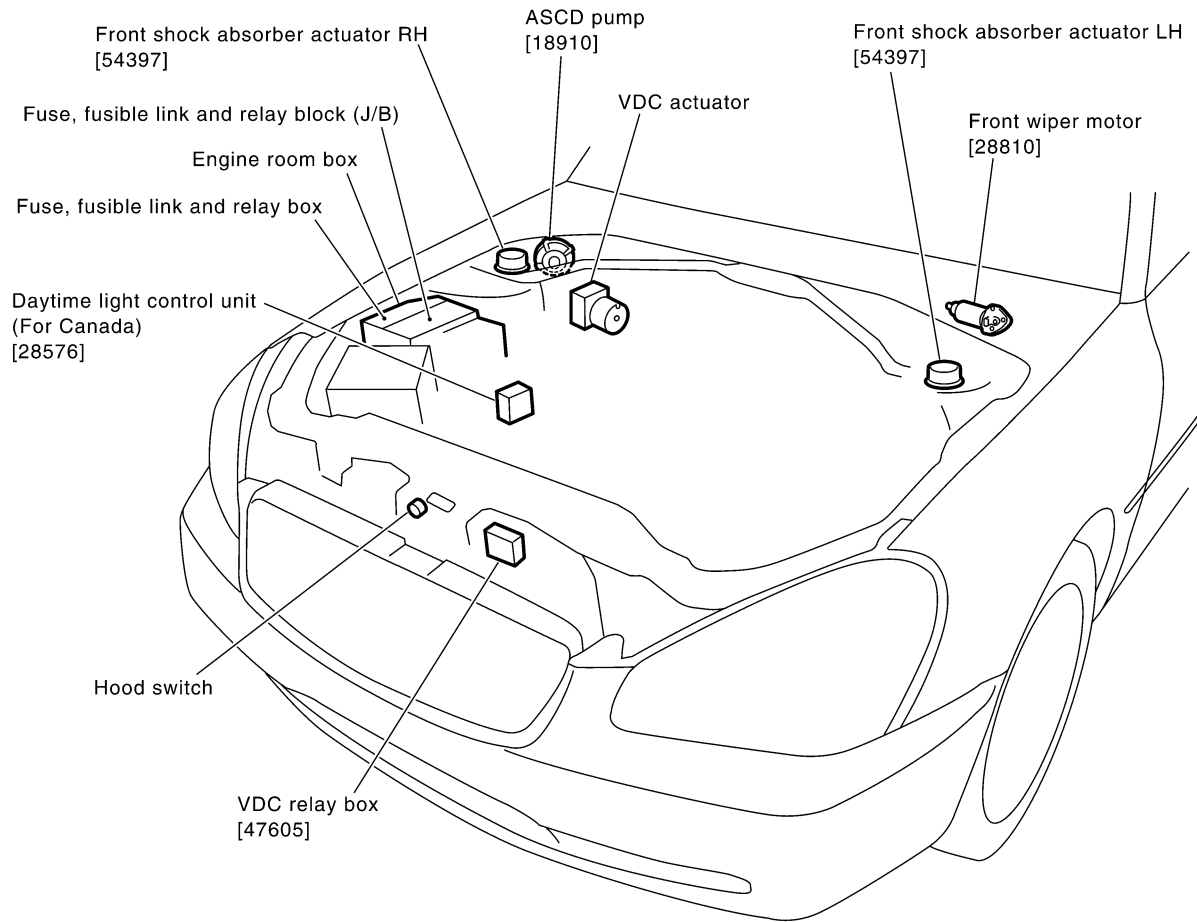

A
B
C
D
E
F
G
H
I
J

PG

L
M

CKIM0149E

ELECTRICAL UNITS LOCATION

PASSENGER COMPARTMENT

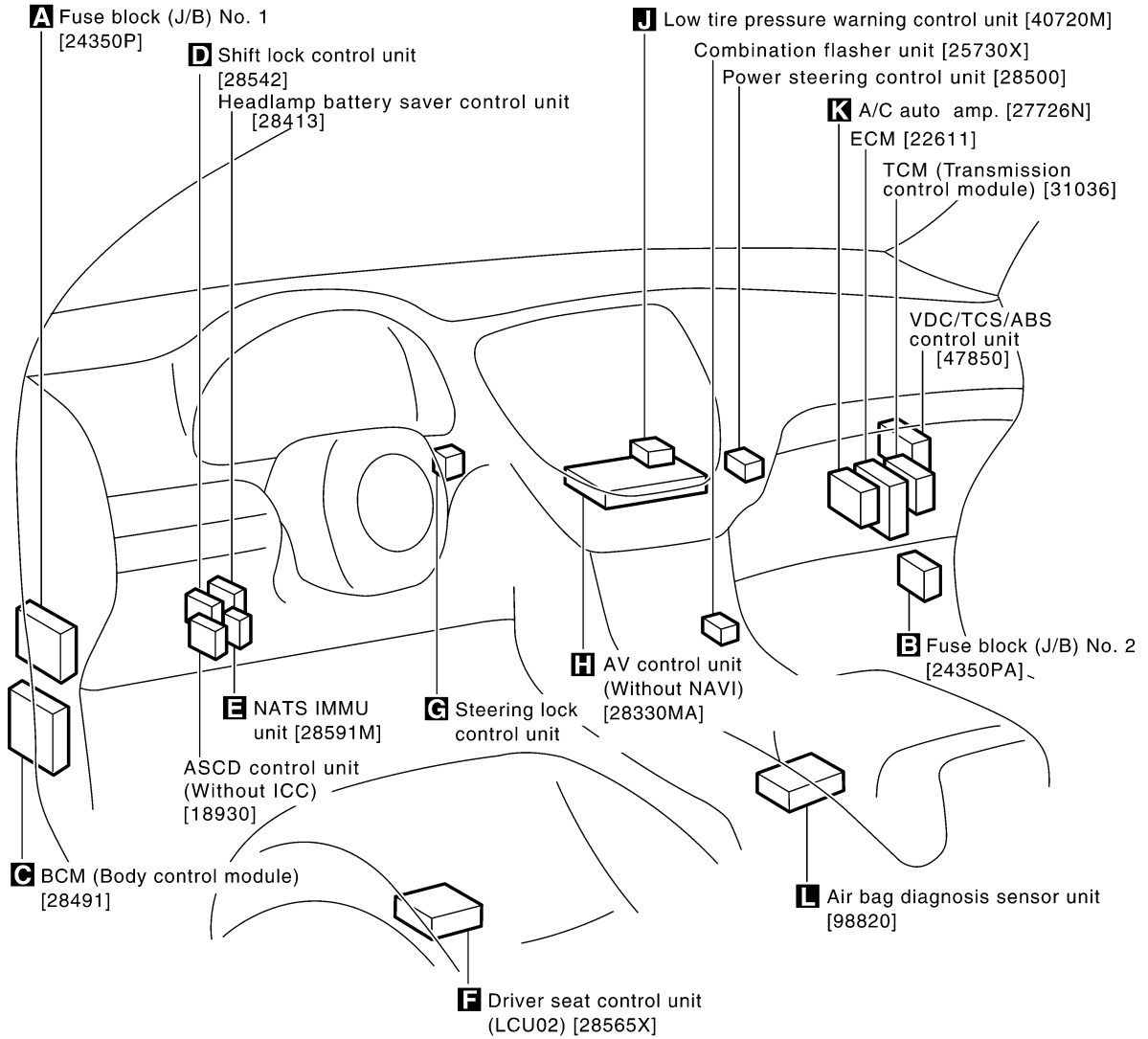

A Dash side LH

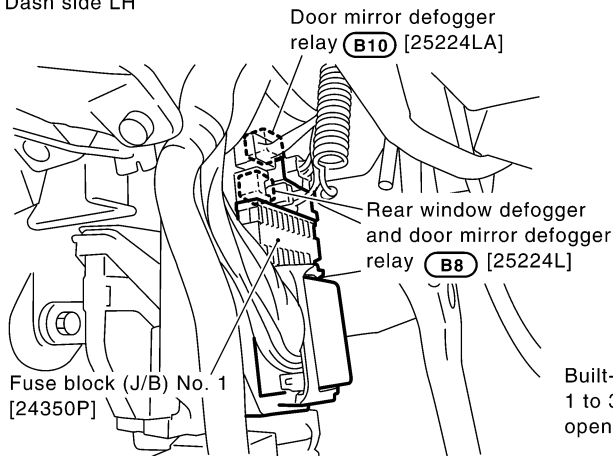

In back of the fuse block (J/B) No. 1

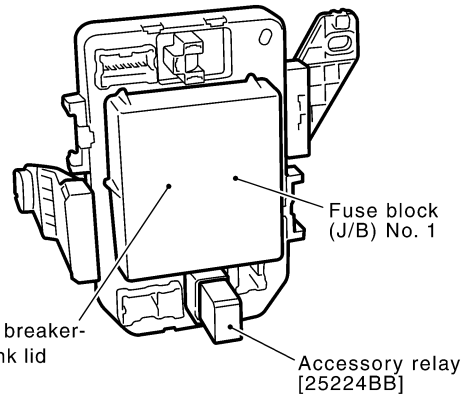

ELECTRICAL UNITS LOCATION

B Dash side RH

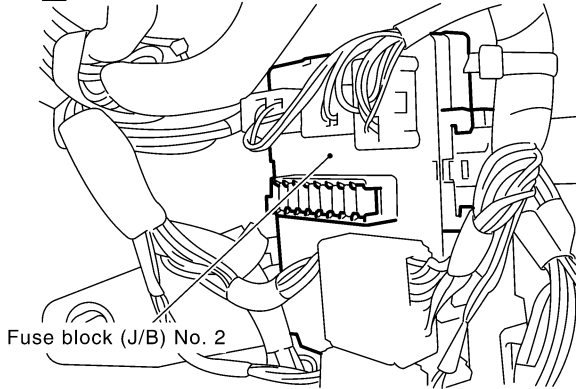

In back of the fuse block (J/B) No. 2

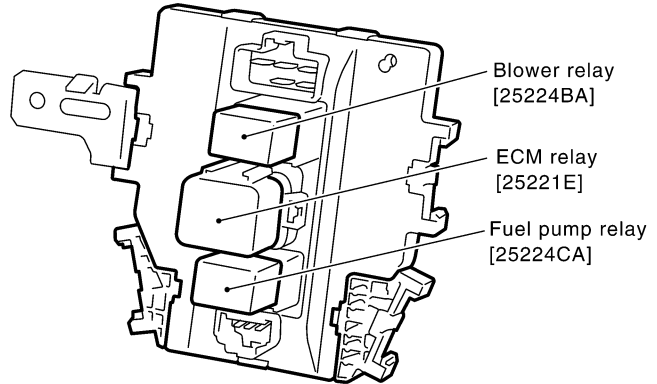

C Dash side LH

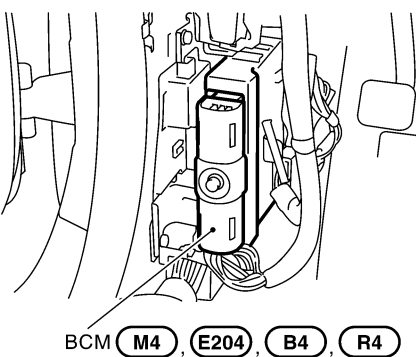

D Driver side view with lower instrument panel removed

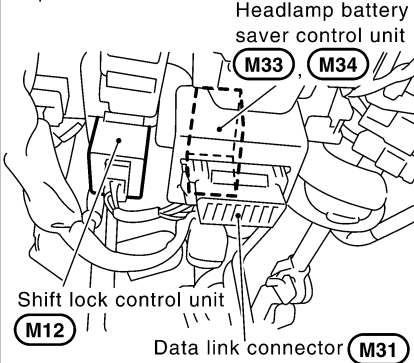

E Driver side view with lower instrument panel removed

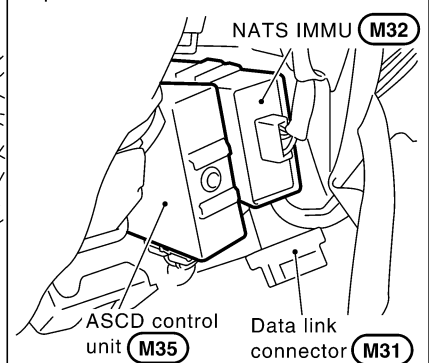

F Under driver seat

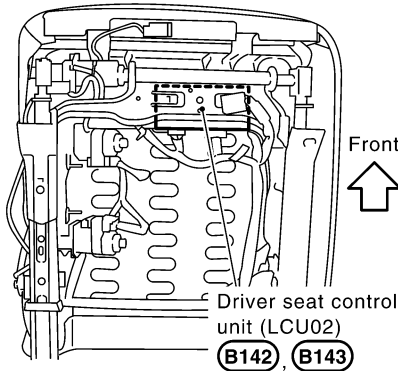

G

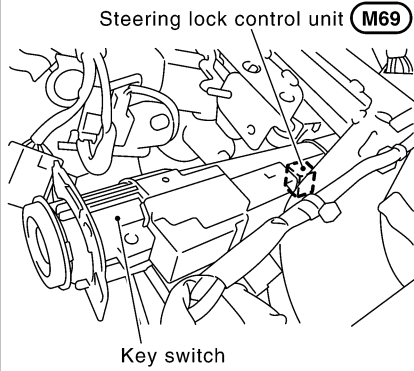

H View with instrument panel center removed

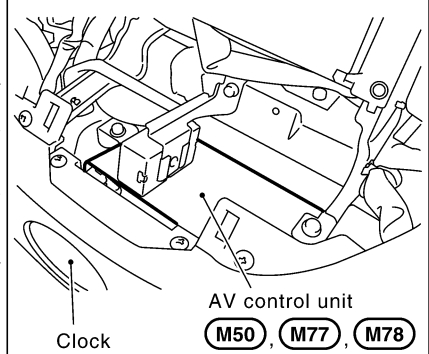

J View with instrument panel center removed

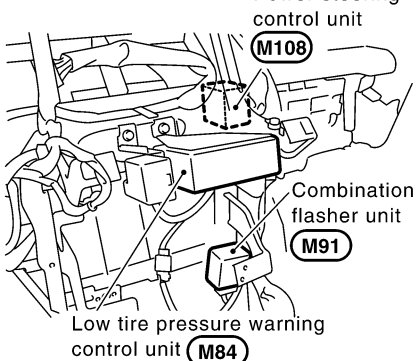

K Behind lower instrument panel on passenger side

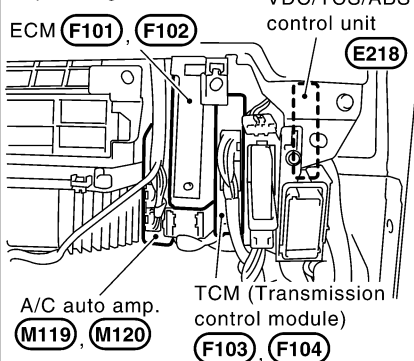

L View with console box removed

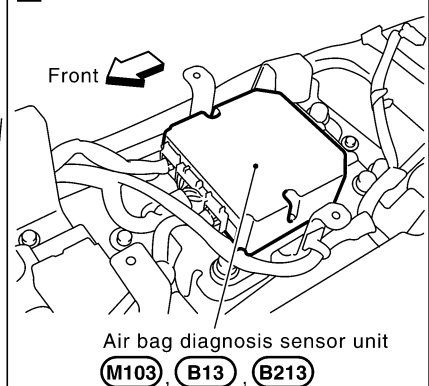

CKIM0191E

A
B
C
D
E
F
G
H
I
J
PG
L
M

ELECTRICAL UNITS LOCATION

Rear power seat control unit RH [28565]

B362, **B363** : With heated seat

B368 : Without heated seat

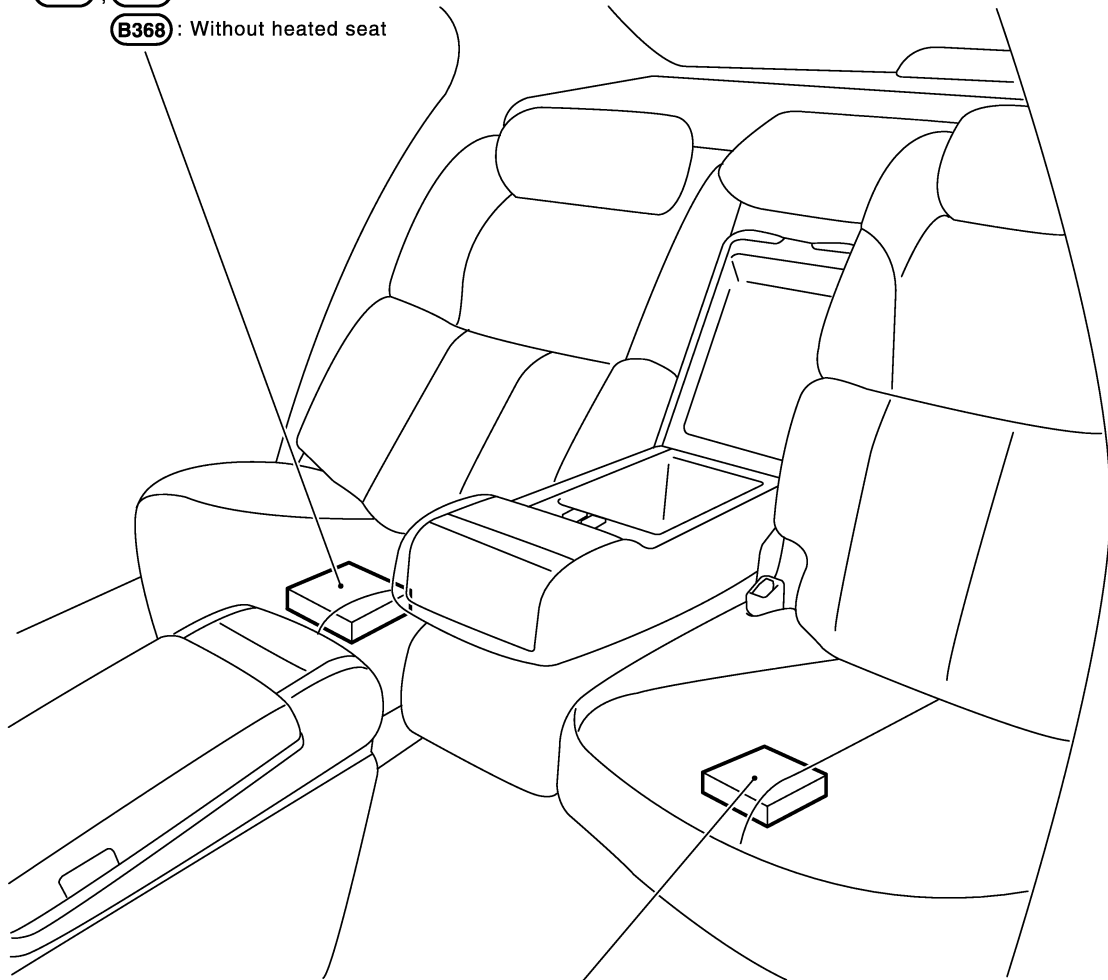

Rear power seat control unit LH [28565X]

B162, **B163** : With heated seat

B168 : Without heated seat

ELECTRICAL UNITS LOCATION

LUGGAGE COMPARTMENT

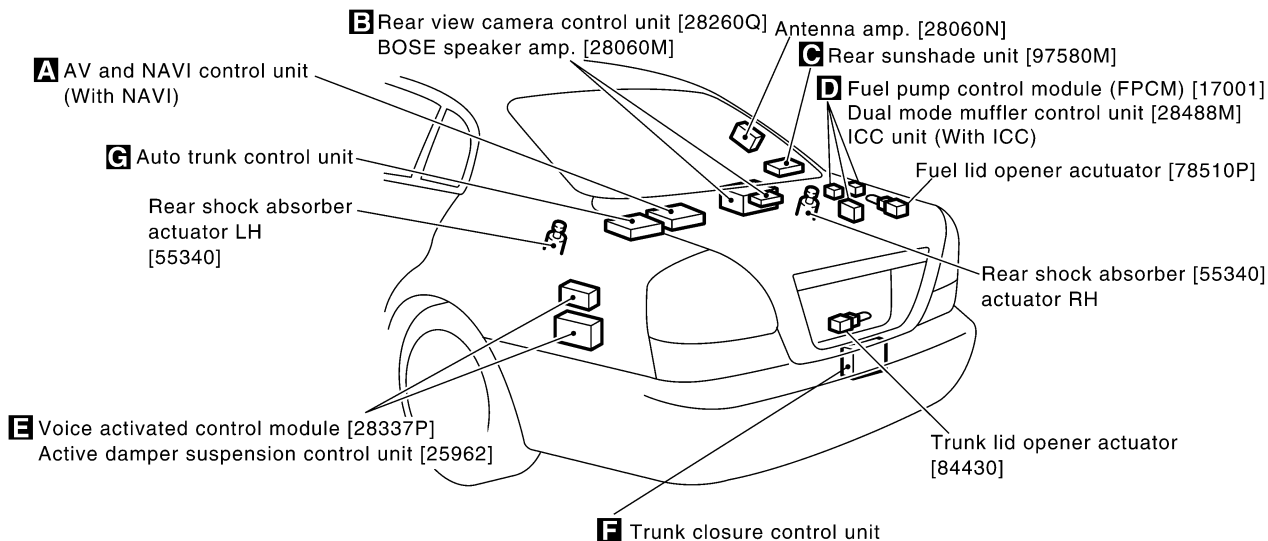

<p>A Lower side of rear parcel shelf finisher</p> <p>AV and NAVI control unit B29, B30</p>	<p>B Lower side of rear parcel shelf finisher</p> <p>Rear view camera control unit B236 BOSE speaker amp. B231, B232, B233, B234</p>	<p>C Rear parcel shelf RH side</p> <p>Rear sunshade unit B225</p>
<p>D RH side trunk room</p> <p>Fuel pump control module (FPCM) B240 ICC unit B243, B244, B245</p>	<p>E LH side trunk room</p> <p>Voice activated control module B69, B71 Active damper suspension control unit B37, B38</p>	<p>F Trunk closure control unit B56</p> <p>Trunk closure control unit B56 Striker</p>
<p>G LH side trunk room</p> <p>Auto trunk control unit B110, B111 Auto trunk motor</p>		

HARNESS CONNECTOR

PF0:00011

HARNESS CONNECTOR

Description

HARNESS CONNECTOR (TAB-LOCKING TYPE)

EKS000DY

- The tab-locking type connectors help prevent accidental looseness or disconnection.
- The tab-locking type connectors are disconnected by pushing or lifting the locking tab(s). Refer to the illustration below.

Refer to the next page for description of the slide-locking type connector.

CAUTION:

Do not pull the harness or wires when disconnecting the connector.

[Example]

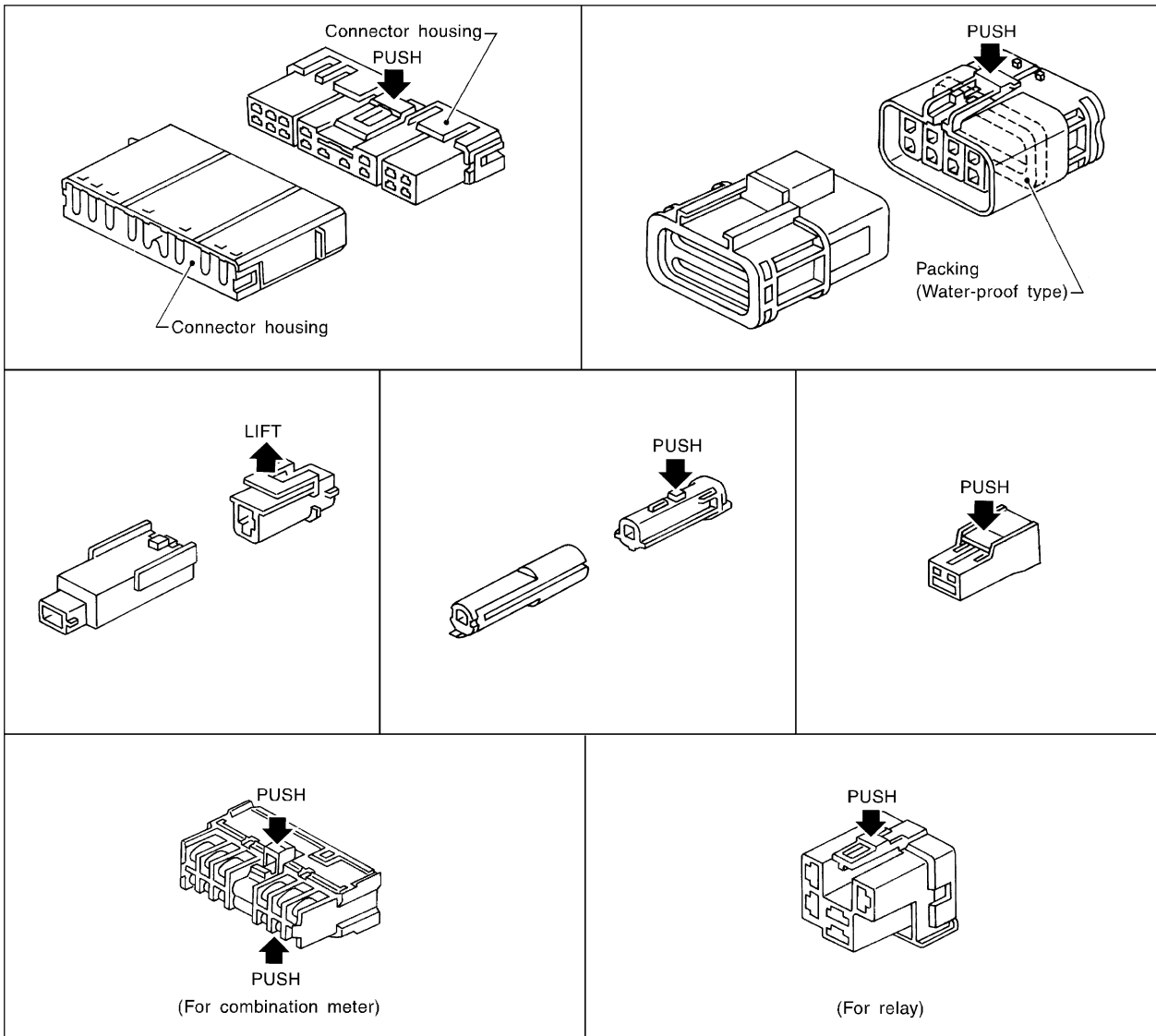

SEL769DA

HARNESS CONNECTOR

HARNESS CONNECTOR (SLIDE-LOCKING TYPE)

- A new style slide-locking type connector is used on certain systems and components, especially those related to OBD.
- The slide-locking type connectors help prevent incomplete locking and accidental looseness or disconnection.
- The slide-locking type connectors are disconnected by pushing or pulling the slider. Refer to the illustration below.

CAUTION:

- Do not pull the harness or wires when disconnecting the connector.
- Be careful not to damage the connector support bracket when disconnecting the connector.

[Example]

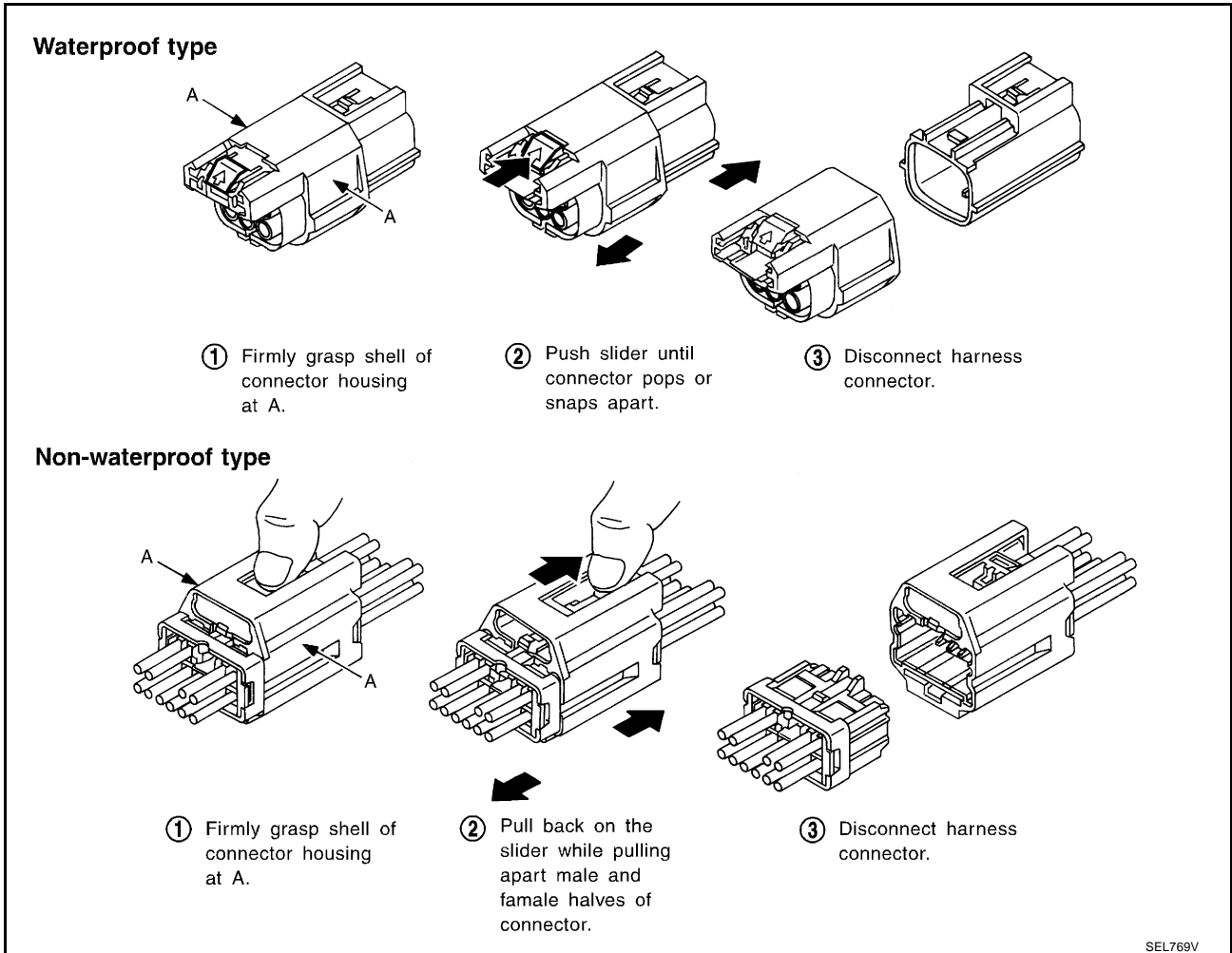

A
B
C
D
E
F
G
H
I
J
PG
L
M

JOINT CONNECTOR (J/C)

PFP:B4341

EKS001B1

JOINT CONNECTOR (J/C)

Terminal Arrangement

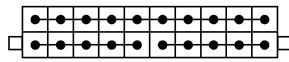

J/C-1 **M9**
 J/C-5 **M38**
 J/C-13 **M81**
 J/C-25 **E216**
 J/C-28 **F106**
 J/C-29 **F107**
 J/C-36 **B241**
 J/C-41 **D14**

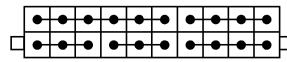

J/C-2 **M10**
 J/C-7 **M46**
 J/C-9 **M48**
 J/C-15 **M124**
 J/C-16 **M125**
 J/C-17 **M126**
 J/C-20 **M129**

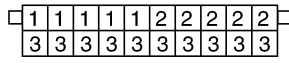

(Pink)

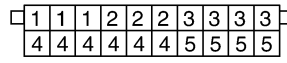

(Black)

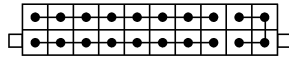

J/C-3 **M21**
 J/C-8 **M47**

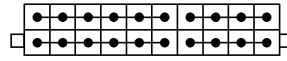

J/C-4 **M22**
 J/C-14 **M123**

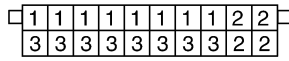

(Gary)

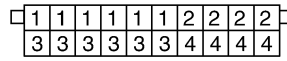

(Blue)

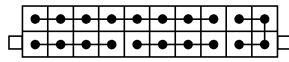

J/C-11 **M79**

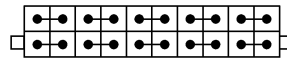

J/C-12 **M80**

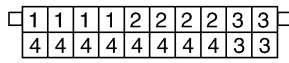

(Green)

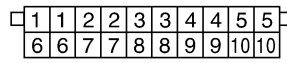

(Red)

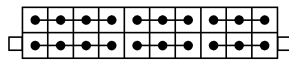

J/C-10 **M49**
 J/C-18 **M127**
 J/C-19 **M128**
 J/C-37 **B242**

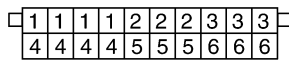

(Orange)

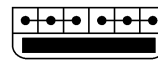

J/C-6 **M45**
 J/C-21 **M130**

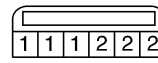

(White)

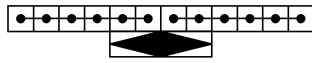

J/C-30 **F108**

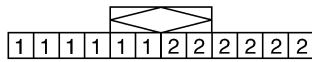

(Blue)

ELECTRICAL UNITS

BCM (BODY CONTROL MODULE)

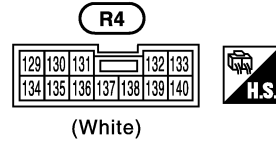
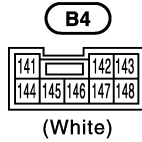
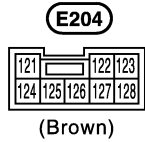
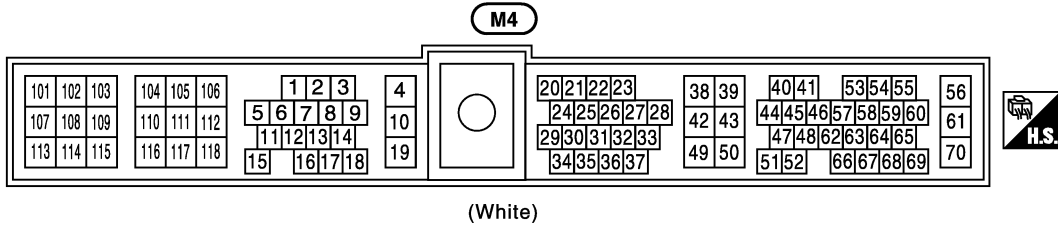

ICC UNIT

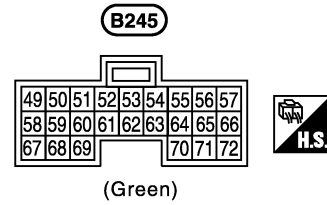
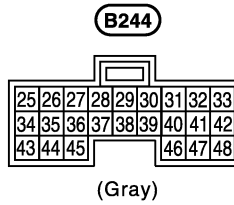
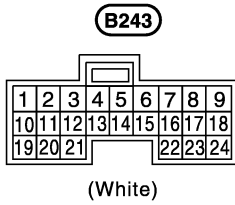

SMJ (SUPER MULTIPLE JUNCTION)

SMJ (SUPER MULTIPLE JUNCTION) Terminal Arrangement

PFP:B4341

EKS001B2

A
B
C
D
E
F
G
H
I
J
PG
L
M

MAIN HARNESS

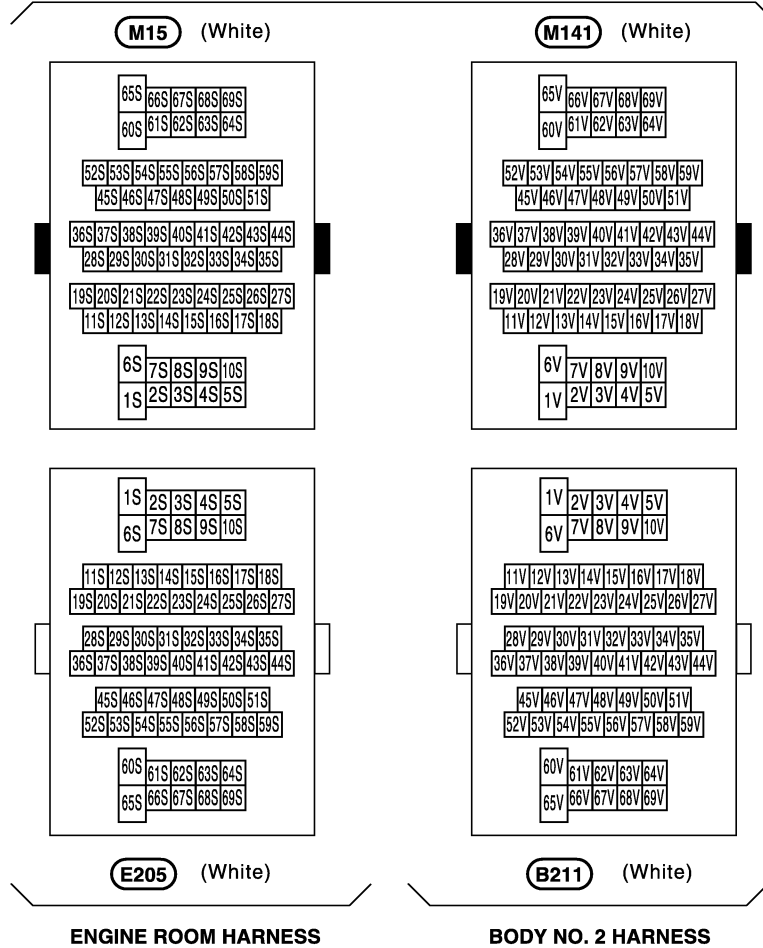

SMJ (SUPER MULTIPLE JUNCTION)



MAIN HARNESS

M5 (White)

1U	2U	3U	4U	5U	11U	12U	13U	14U	15U	16U	17U	18U	19U	20U	30U	31U	32U	33U	34U	35U	36U	37U	38U				
6U	7U	8U	9U	10U	21U	22U	23U	24U	25U	26U	27U	28U	29U	39U	40U	41U	42U	43U	44U	45U	46U						

6U	7U	8U	9U	10U	21U	22U	23U	24U	25U	26U	27U	28U	29U	39U	40U	41U	42U	43U	44U	45U	46U		
1U	2U	3U	4U	5U	11U	12U	13U	14U	15U	16U	17U	18U	19U	20U	30U	31U	32U	33U	34U	35U	36U	37U	38U

B5 (White)

BODY HARNESS



MAIN HARNESS

M135 (White)

6T	7T	8T	9T	10T	21T	22T	23T	24T	25T	26T	27T	28T	29T	39T	40T	41T	42T	43T	44T	45T	46T		
1T	2T	3T	4T	5T	11T	12T	13T	14T	15T	16T	17T	18T	19T	20T	30T	31T	32T	33T	34T	35T	36T	37T	38T

1T	2T	3T	4T	5T	11T	12T	13T	14T	15T	16T	17T	18T	19T	20T	30T	31T	32T	33T	34T	35T	36T	37T	38T
6T	7T	8T	9T	10T	21T	22T	23T	24T	25T	26T	27T	28T	29T	39T	40T	41T	42T	43T	44T	45T	46T		

F105 (White)

ENGINE CONTROL HARNESS



MAIN HARNESS

M11 (White)

20W	21W	22W	23W	24W	25W	26W	27W	36W	37W	38W	39W		
11W	12W	13W	14W	15W	16W	17W	18W	19W	32W	33W	34W	35W	
1W	2W	3W	4W	5W	6W	7W	8W	9W	10W	28W	29W	30W	31W

M142 (White)

20X	21X	22X	23X	24X	25X	26X	27X	36X	37X	38X	39X		
11X	12X	13X	14X	15X	16X	17X	18X	19X	32X	33X	34X	35X	
1X	2X	3X	4X	5X	6X	7X	8X	9X	10X	28X	29X	30X	31X

D1 (White)

11W	12W	13W	14W	15W	16W	17W	18W	19W	28W	29W	30W	31W	
20W	21W	22W	23W	24W	25W	26W	27W	32W	33W	34W	35W		
1W	2W	3W	4W	5W	6W	7W	8W	9W	10W	36W	37W	38W	39W

D31 (White)

11X	12X	13X	14X	15X	16X	17X	18X	19X	28X	29X	30X	31X	
20X	21X	22X	23X	24X	25X	26X	27X	32X	33X	34X	35X		
1X	2X	3X	4X	5X	6X	7X	8X	9X	10X	36X	37X	38X	39X

FRONT DOOR HARNESS (DRIVER SIDE)

FRONT DOOR HARNESS (PASSENGER SIDE)

SMJ (SUPER MULTIPLE JUNCTION)

A
B
C
D
E
F
G
H
I
J
PG
L
M

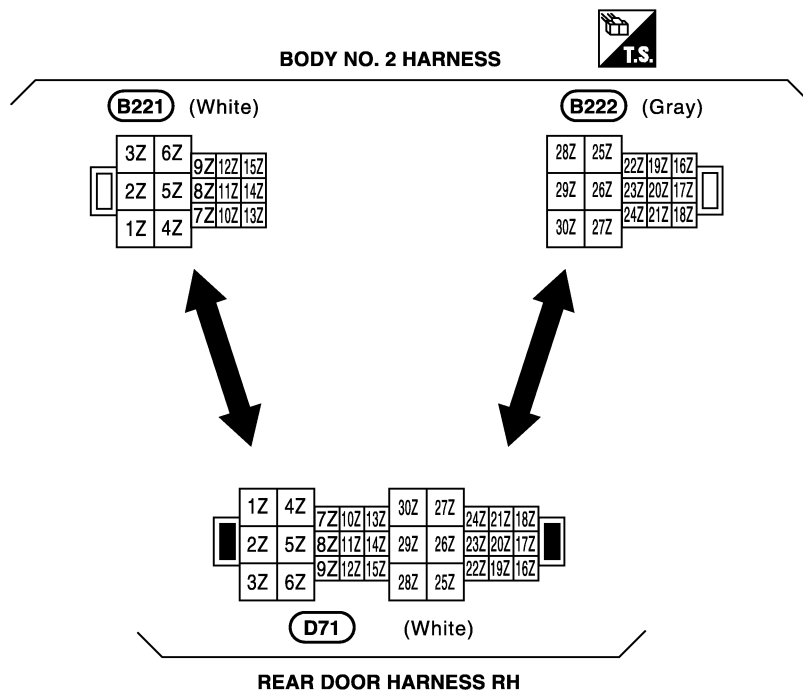
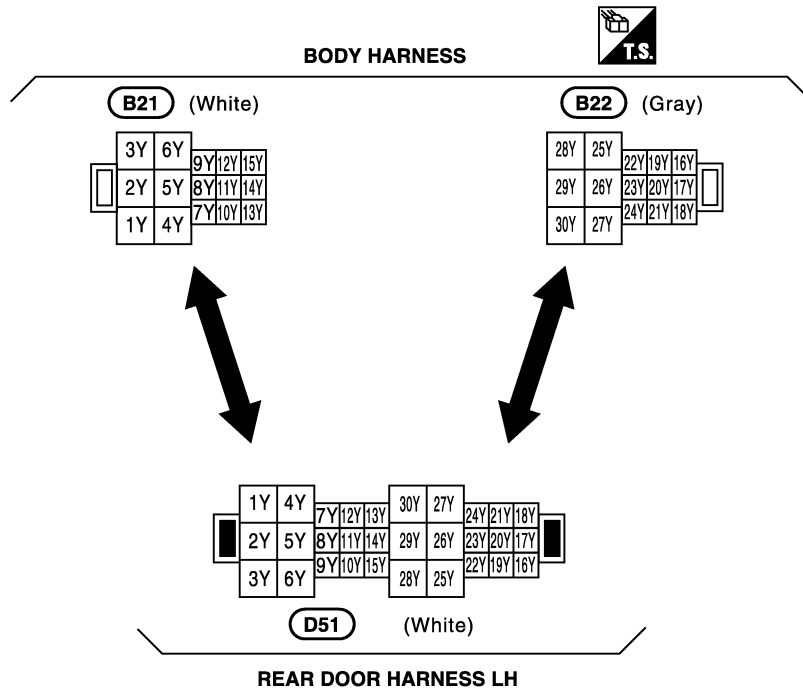

STANDARDIZED RELAY

PPF:00011

EKS000E4

STANDARDIZED RELAY

Description NORMAL OPEN, NORMAL CLOSED AND MIXED TYPE RELAYS

Relays can mainly be divided into three types: normal open, normal closed and mixed type relays.

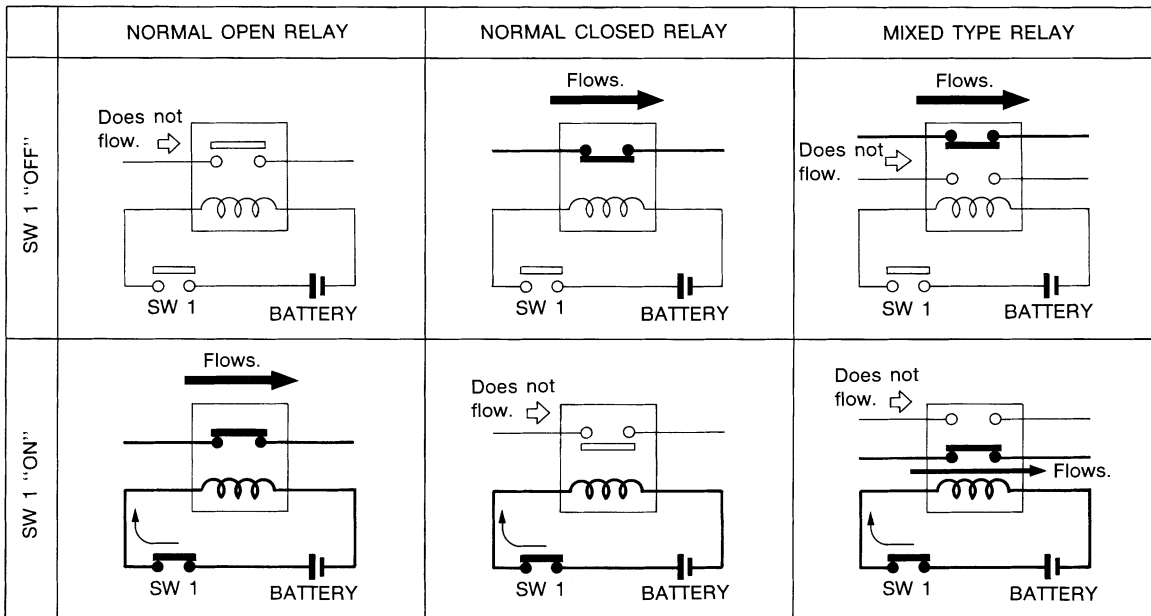

SEL881H

TYPE OF STANDARDIZED RELAYS

- 1M 1 Make
- 2M 2 Make
- 1T 1 Transfer
- 1M-1B 1 Make 1 Break

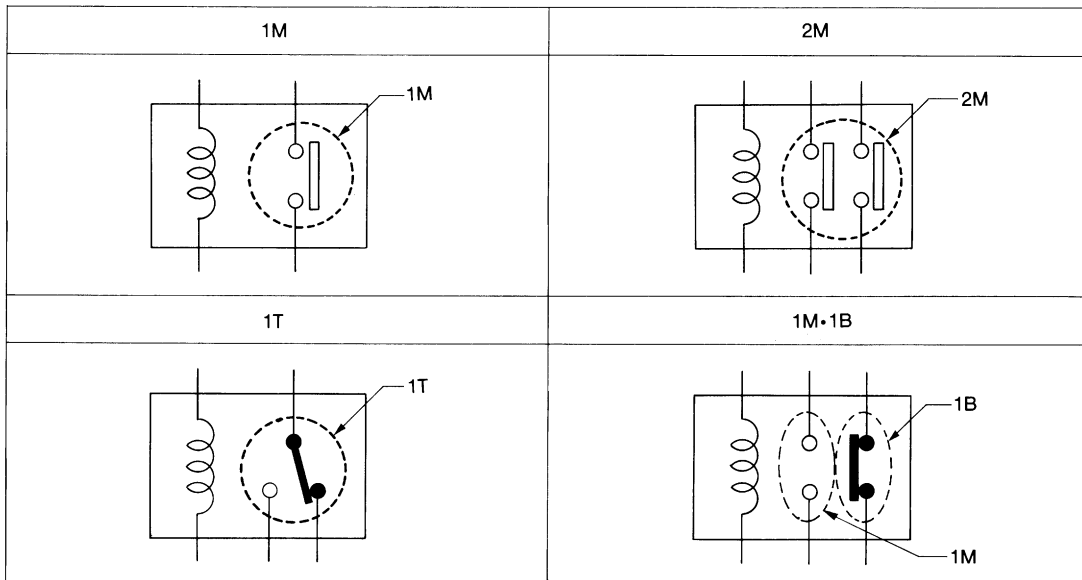

SEL882H

STANDARDIZED RELAY

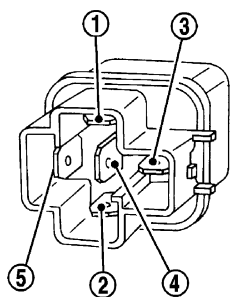
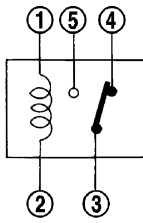
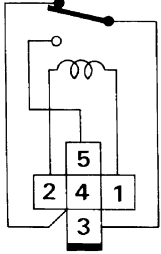
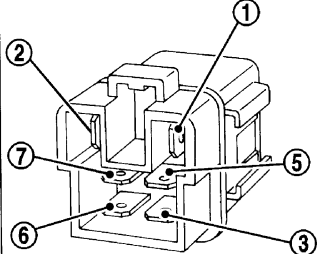
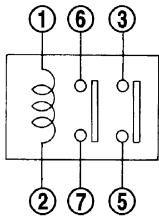
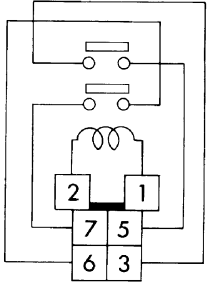
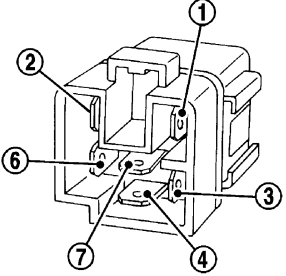
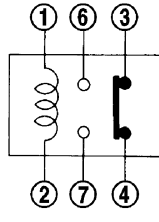
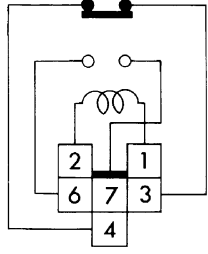
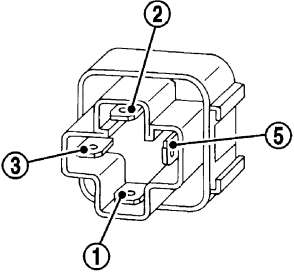
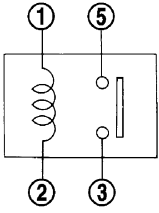
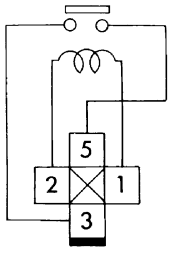
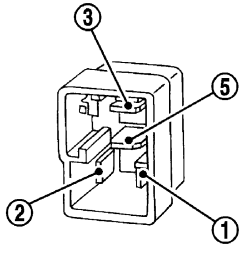
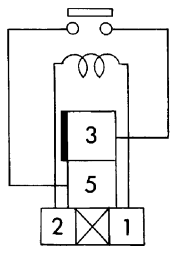
Type	Outer view	Circuit	Connector symbol and connection	Case color
1T				BLACK
2M				BROWN
1M•1B				GRAY
1M				BLUE
				

The arrangement of terminal numbers on the actual relays may differ from those shown above.

SEL188W

A
B
C
D
E
F
G
H
I
J
PG
L
M

FUSE BLOCK - JUNCTION BOX (J/B) NO.1

PFP:24350

EKS00178

FUSE BLOCK - JUNCTION BOX (J/B) NO.1

Terminal Arrangement

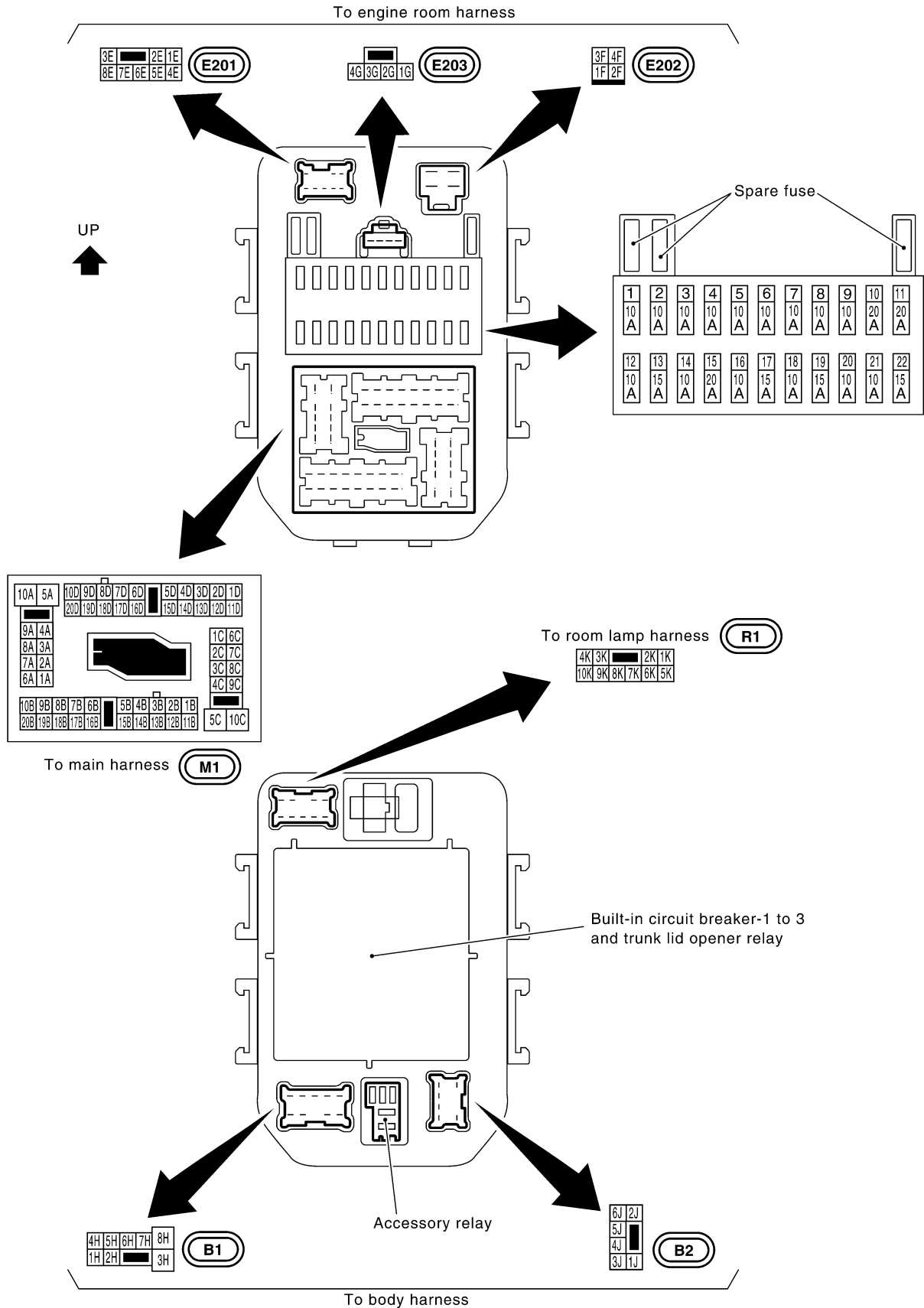

CKIM0246E

FUSE BLOCK - JUNCTION BOX (J/B) NO.2

FUSE BLOCK - JUNCTION BOX (J/B) NO.2

PFP:24350

Terminal Arrangement

EKS00175

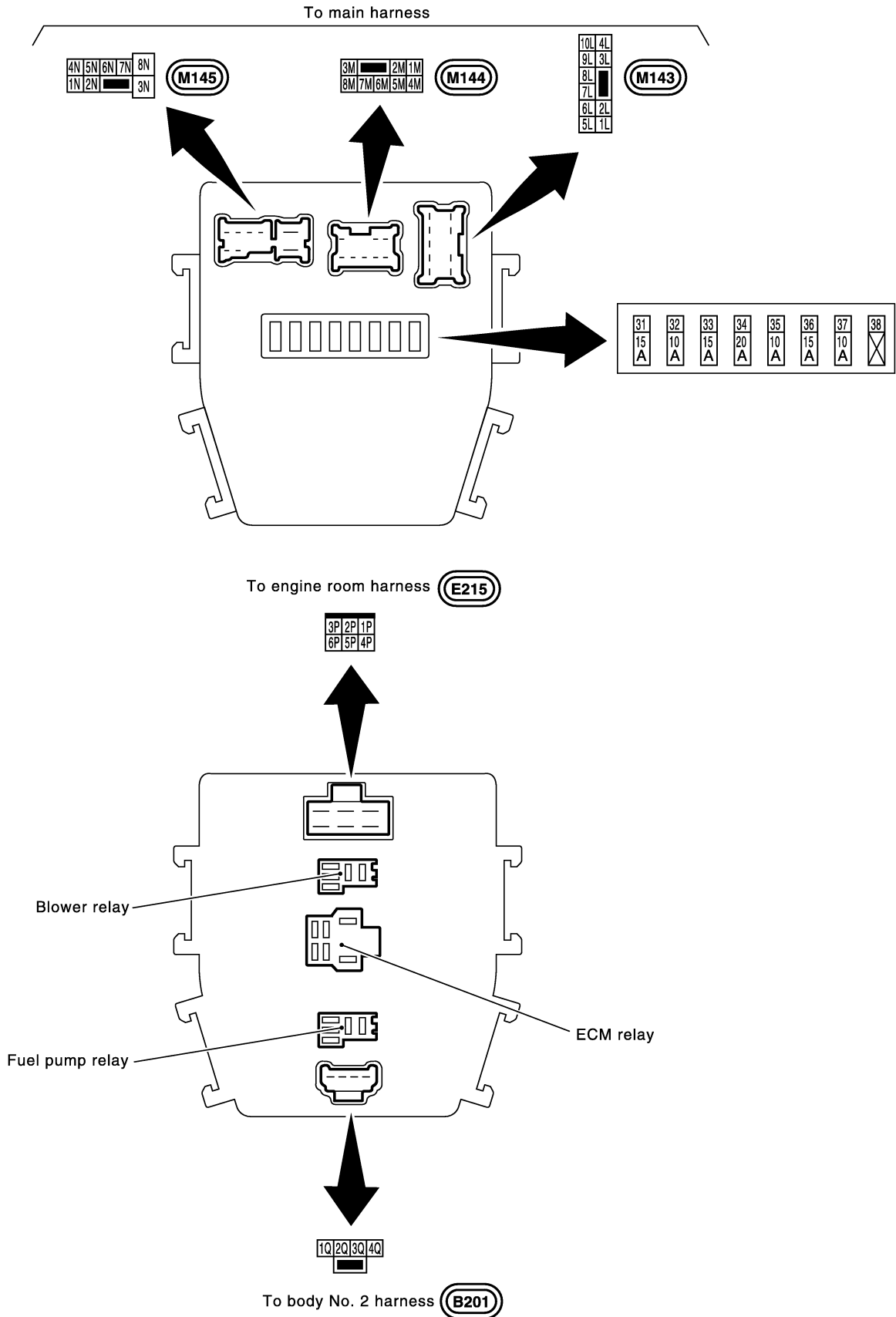

A
B
C
D
E
F
G
H
I
J
PG
L
M

PG

FUSE, FUSIBLE LINK AND RELAY BLOCK (J/B)

PFP:24382

EKS00176

FUSE, FUSIBLE LINK AND RELAY BLOCK (J/B) Terminal Arrangement

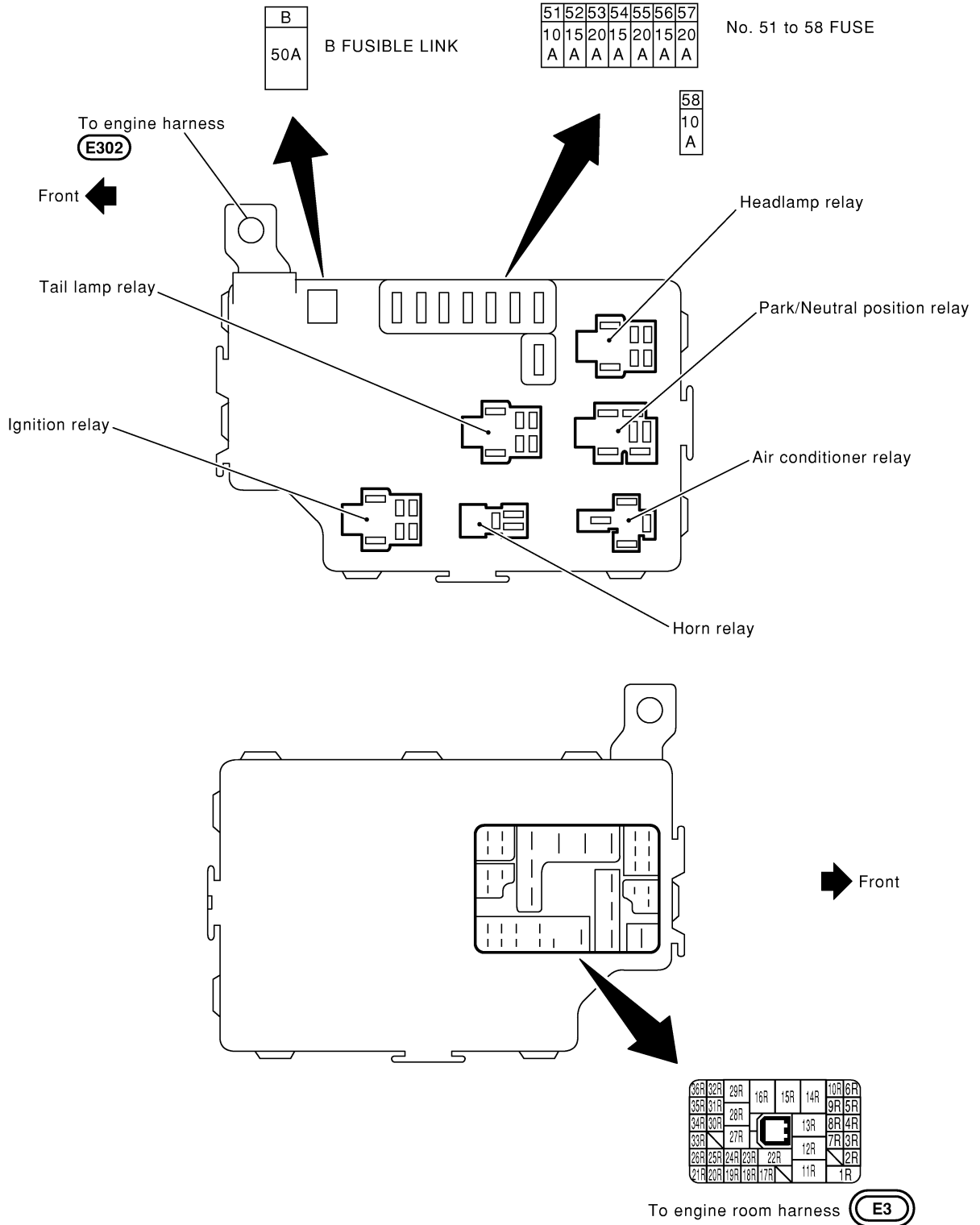

FUSE, FUSIBLE LINK AND RELAY BOX

FUSE, FUSIBLE LINK AND RELAY BOX

PPF:24382

Terminal Arrangement

EKS00177

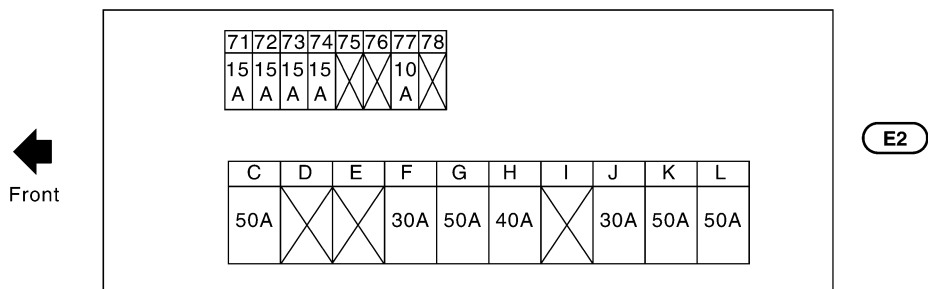
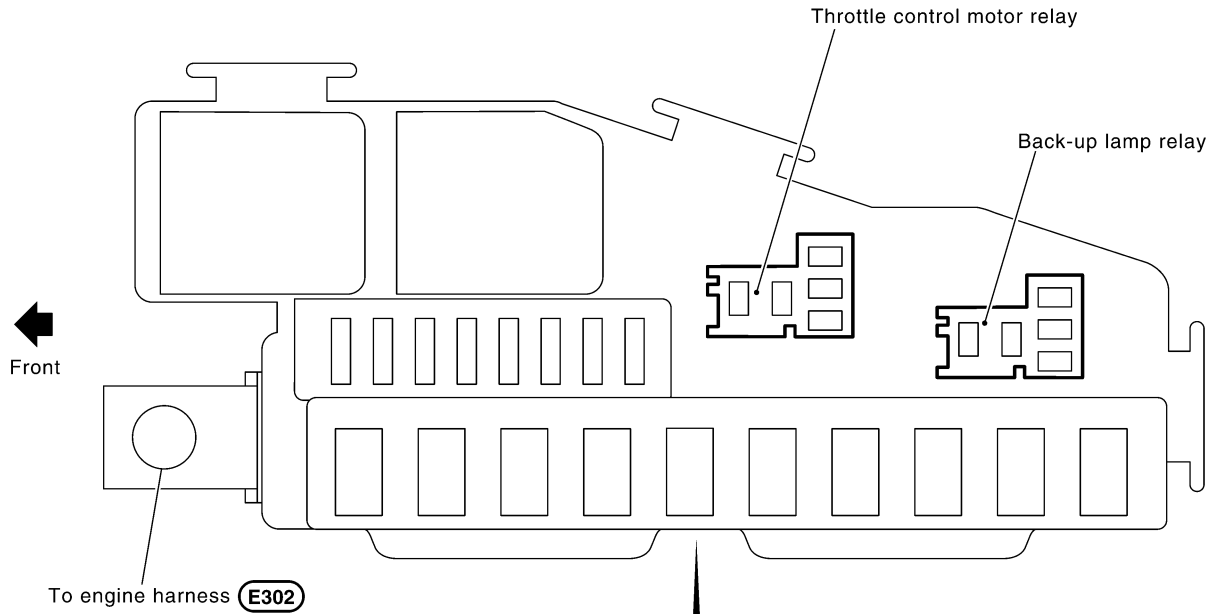

C to L FUSIBLE LINK
No. 71 to 78 FUSE

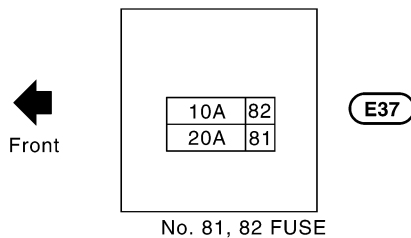

No. 81, 82 FUSE

A
B
C
D
E
F
G
H
I
J
PG
L
M

FUSE, FUSIBLE LINK AND RELAY BOX
