

SECTION **RAX**  
REAR AXLE

A  
B  
C

RAX

CONTENTS

E

<b>PRECAUTIONS</b> .....	2	<b>INSTALLATION</b> .....	6	F
Caution .....	2	Disassembly and Assembly .....	6	
<b>PREPARATION</b> .....	3	DISASSEMBLY .....	6	G
Special Service Tools (SST) .....	3	INSPECTION AFTER DISASSEMBLY .....	7	
Commercial Service Tools .....	3	ASSEMBLY .....	7	
<b>NOISE, VIBRATION AND HARSHNESS (NVH)</b>		INSPECTION AFTER ASSEMBLY .....	8	H
<b>TROUBLESHOOTING</b> .....	4	<b>REAR DRIVE SHAFT</b> .....	9	
NVH Troubleshooting Chart .....	4	Removal and Installation .....	9	
<b>WHEEL HUB</b> .....	5	REMOVAL .....	9	I
On-Vehicle Inspection and Service .....	5	INSPECTION AFTER REMOVAL .....	9	
WHEEL BEARING INSPECTION .....	5	INSTALLATION .....	9	
Removal and Installation .....	5	Disassembly and Assembly .....	10	J
REMOVAL .....	5	DISASSEMBLY .....	10	
INSPECTION AFTER REMOVAL .....	6	INSPECTION AFTER DISASSEMBLY .....	11	
		ASSEMBLY .....	12	K
		<b>SERVICE DATA</b> .....	15	
		Wheel Bearing .....	15	
		Drive Shaft .....	15	L
		Tightening Torque .....	15	

L  
M

# PRECAUTIONS

---

## PRECAUTIONS

PFP:00001

### Caution

EDS000WJ

Observe the following precautions when disassembling and servicing drive shaft.

- Perform work in a location which is as dust-free as possible.
- Before disassembling and servicing, clean the outside of parts.
- Prevention of the entry of foreign objects must be taken into account during disassembly of the service location.
- Disassembled parts must be carefully reassembled in the correct order. If work is interrupted, a clean cover must be placed over parts.
- Paper shop cloths must be used. Fabric shop cloths must not be used because of the danger of lint adhering to parts.
- Disassembled parts (except for rubber parts) should be cleaned with kerosene which shall be removed by blowing with air or wiping with paper shop cloths.

# PREPARATION

## PREPARATION

PFP:00002

### Special Service Tools (SST)

EDS000WK

The actual shapes of Kent-Moore tools may differ from those of special service tools illustrated here.

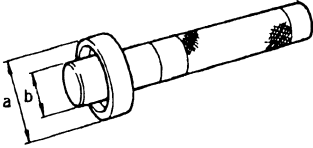
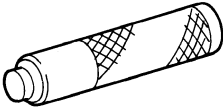
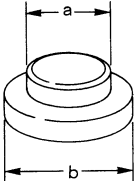
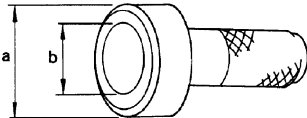
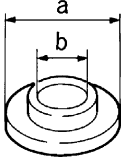
Tool number (Kent-Moore No.) Tool name	Description
ST3322 0000 ( — ) Drift a: 32 mm (1.26 in) dia. b: 21 mm (0.83 in) dia.	 <ul style="list-style-type: none"> <li>● Removing wheel hub</li> <li>● Removing wheel bearing outer side inner race</li> </ul>
ST3325 1000 ( — ) Drift	 <ul style="list-style-type: none"> <li>● Installing wheel hub</li> </ul>
ST3530 0000 ( — ) Drift a: 45 mm (1.77 in) dia. b: 59 mm (2.32 in) dia.	 <p>Installing wheel hub</p>
KV381 00500 ( — ) Drift a: 80 mm (3.15 in) dia b: 60 mm (2.36 in) dia	 <p>Installing drive shaft plug</p>
KV381 02200 ( — ) Drift a: 90 mm (3.54 in) dia b: 31 mm (1.22 in) dia	 <p>Installing drive shaft plug</p>

## Commercial Service Tools

EDS000WL

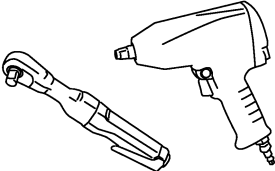
Tool name	Description
Power tool	 <ul style="list-style-type: none"> <li>● Removing wheel nuts</li> <li>● Removing brake caliper assembly</li> </ul>

# NOISE, VIBRATION AND HARSHNESS (NVH) TROUBLESHOOTING

## NOISE, VIBRATION AND HARSHNESS (NVH) TROUBLESHOOTING

PFP:00003

### NVH Troubleshooting Chart

EDS000WM

Use chart below to help you find the cause of the symptom. If necessary, repair or replace these parts.

Reference page			—	<a href="#">RAX-11</a>	—	<a href="#">RAX-5</a>	—	NVH in PR section.	NVH in RFD section.	NVH in FAX and FSU sections.	Refer to REAR AXLE in this chart.	NVH in WT section.	NVH in WT section.	Refer to DRIVE SHAFT in this chart.	NVH in BR section.	NVH in PS section.	
Possible cause and SUSPECTED PARTS			Excessive joint angle	Joint sliding resistance	Imbalance	Improper installation, looseness	Parts interference	PROPELLER SHAFT	DIFFERENTIAL	FRONT AXLE AND FRONT SUSPENSION	REAR AXLE	TIRES	ROAD WHEEL	DRIVE SHAFT	BRAKES	STEERING	
Symptom	DRIVE SHAFT	Noise	x	x				x	x	x	x	x	x		x	x	
		Shake	x		x			x		x	x	x	x		x	x	
	REAR AXLE	Noise				x	x	x	x	x		x	x	x	x	x	x
		Shake				x	x	x		x		x	x	x	x	x	x
		Vibration				x	x	x		x		x		x			x
		Shimmy				x	x				x		x	x		x	x
		Judder				x					x		x	x		x	x
		Poor quality ride or handling				x	x				x		x	x			

x: Applicable

# WHEEL HUB

## WHEEL HUB

PF:43202

### On-Vehicle Inspection and Service

EDS000WN

Make sure the mounting conditions (looseness, back lash) of each component and component status (wear, damage) are normal.

### WHEEL BEARING INSPECTION

- Move wheel hub in the axial direction by hand. Make sure there is no looseness of wheel bearing.

**Axial end play : 0.05 mm (0.002 in) or less**

- Rotate wheel hub and make sure there is no unusual noise or other irregular conditions. If there are any irregular conditions, replace wheel bearings.

### Removal and Installation

EDS000WO

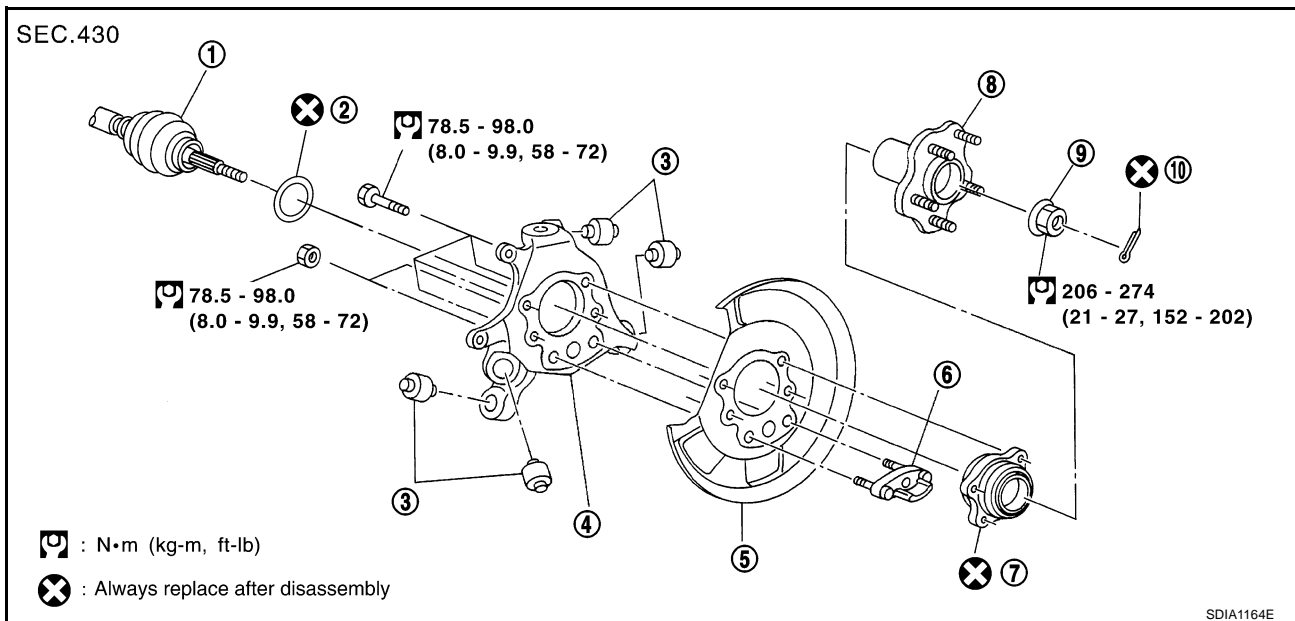

- |                  |                |                 |
|------------------|----------------|-----------------|
| 1. Drive shaft   | 2. Dust shield | 3. Bushing      |
| 4. Axle          | 5. Back plate  | 6. Anchor block |
| 7. Wheel bearing | 8. Wheel hub   | 9. Lock nut     |
| 10. Cotter pin   |                |                 |

### REMOVAL

1. Remove tire from vehicle with power tool.
2. Remove brake caliper with power tool. Hang it in a place where it will not interfere with work. Refer to [BR-30, "REAR DISC BRAKE"](#).

#### NOTE:

Avoid depressing brake pedal while brake caliper is removed.

3. Remove cotter pin. Then remove lock nut from drive shaft.
4. Remove disc rotor and remove parking cable and parking brake shoe from back plate. Refer to [PB-4, "PARKING BRAKE CONTROL"](#), [PB-6, "PARKING BRAKE SHOE"](#).
5. Remove fixing bolts and nuts in axle side of radius rod, front lower link.
6. Remove fixing bolt and nut in axle side of rear lower link. Then remove coil spring. Refer to [RSU-15, "REAR LOWER LINK & COIL SPRING"](#).
7. Remove fixing bolt and nut in axle side of shock absorber.
8. Using a puller (suitable tool), remove axle from drive shaft.

#### CAUTION:

- When removing axle, do not apply an excessive angle to drive shaft joint. Also be careful not to excessively extend slide joint.

# WHEEL HUB

- Do not allow drive shaft to hang down without support for counter shaft, wheel joints, and other parts.
9. Remove suspension arm and cotter pin at axle, then loosen mounting nut.
  10. Use a ball joint remover (suitable tool) to remove suspension arm from axle. Be careful not to damage ball joint boot.  
**CAUTION:**  
Tighten temporarily mounting nut to prevent damage to threads and to prevent ball joint remover (suitable tool) from coming off.
  11. Remove axle from vehicle.

## INSPECTION AFTER REMOVAL

### Ball Joint Inspection

Check for boot breakage, axial looseness, and torque of suspension arm ball joint. Refer to [RSU-11, "SUSPENSION ARM"](#) .

## INSTALLATION

- Refer to [RAX-5, "Removal and Installation"](#) for tightening torque. Install in the reverse order of removal.
- NOTE:**  
Refer to component parts location and do not reuse non-reusable parts.
- Perform final tightening of installation position of suspension links (rubber bushing) under unladen conditions with tires on level ground, check wheel alignment. Refer to [RSU-5, "Wheel Alignment Inspection"](#) .
  - After adjusting wheel alignment, adjust neutral position of steering angle sensor. Refer to [BRC-6, "Adjustment of Steering Angle Sensor Neutral Position"](#) .

## Disassembly and Assembly

### DISASSEMBLY

#### Wheel Bearing

**CAUTION:**

Do not disassemble if wheel bearing has no trouble.

1. Remove wheel bearing fixing bolts and anchor block fixing nuts, and remove wheel hub and bearing assembly, back plate and anchor block from axle.
2. Using a drift (SST) and a puller (suitable tool), press wheel hub out to remove from wheel bearing.

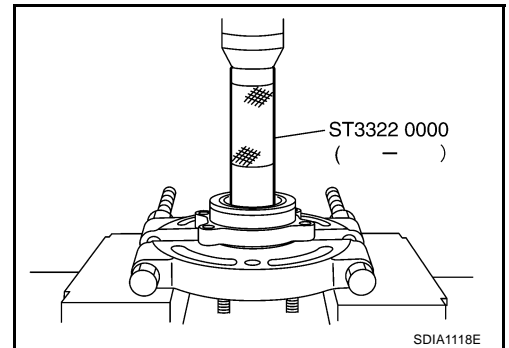

3. Using a drift (SST) and a puller (suitable tool), press wheel bearing outer side inner race out to remove from wheel hub.

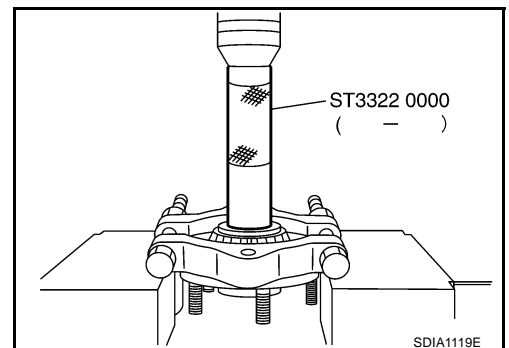

# WHEEL HUB

## Bushing

- Using a suitable drift, remove each bushing from axle.

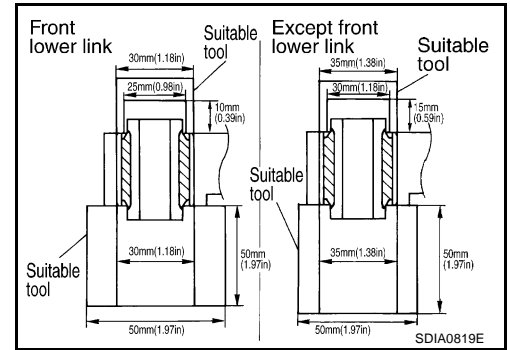

## INSPECTION AFTER DISASSEMBLY

### Wheel Hub

- Inspect wheel hub for deformation, cracks, and other damage. If any irregular conditions are found, replace wheel hub.

### Axle

- Inspect axle for deformation, cracks, and other damage. If any irregular conditions are found, replace axle.

### Back Plate

- Inspect back plate for deformation, cracks, and other damage. If any irregular conditions are found, replace back plate.

## ASSEMBLY

### Bushing

- Using a suitable drift to install each bushing onto axle.

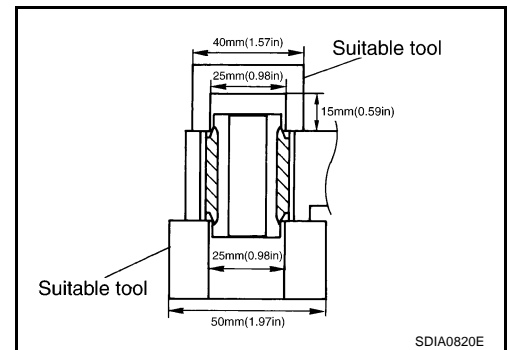

### Wheel Bearing

- Press fit a wheel hub into wheel bearing with a drift (SST).

#### CAUTION:

- Press fit a drift (SST) while holding it against wheel bearing inner side inner race.
- Wheel bearing cannot be reused. Do not attempt to reuse it.

#### NOTE:

Final press load guideline 49, 033 N (5, 000 kg, 11, 000 lb)

- Install back plate and wheel hub and bearing assembly.
- Install anchor block onto axle.

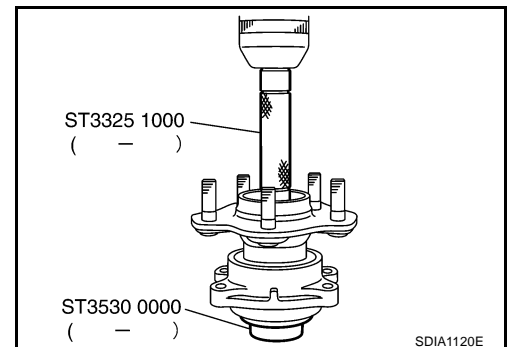

# WHEEL HUB

## INSPECTION AFTER ASSEMBLY

1. With wheel bearing pressed into axle, apply 49, 033 N (5, 000 kg, 11, 000 lb) to wheel hub and rotate both clockwise and counterclockwise 10 times to minimize resistance.
2. Attach spring scale in the position shown in illustration and pull at a rate of  $10 \pm 2$  rpm to measure rotating torque.

**Standard value**

**Rotating torque:**

**Less than 1.49 N·m (0.15 kg·m, 13 in·lb)**

**Spring scale reading:**

**Less than 12.8 N (1.31 kg, 2.88 lb)**

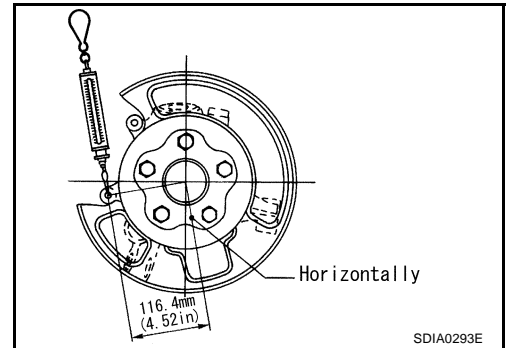



# REAR DRIVE SHAFT

## REAR DRIVE SHAFT

PFP:39600

### Removal and Installation

EDS000WQ

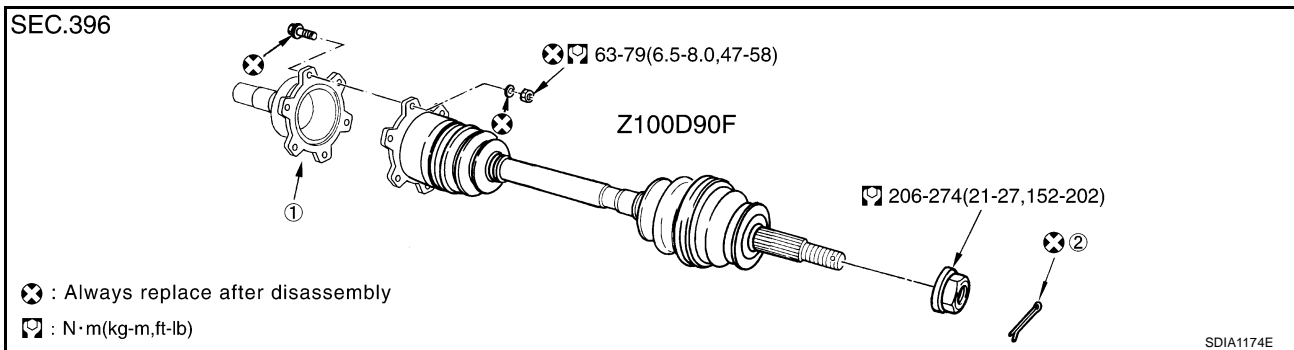

1. Side flange

2. Cotter pin

### REMOVAL

1. Remove tire from vehicle with power tool.
2. Remove cotter pin. Then remove lock nut from drive shaft.
3. Remove exhaust center tube. Refer to [EX-3, "EXHAUST SYSTEM"](#).
4. Remove fixing nuts and bolts between final drive and drive shaft.
5. Using a puller (suitable tool), remove drive shaft from axle.

#### CAUTION:

When removing drive shaft, do not apply an excessive angle to drive shaft joint. Also be careful not to excessively extend slide joint.

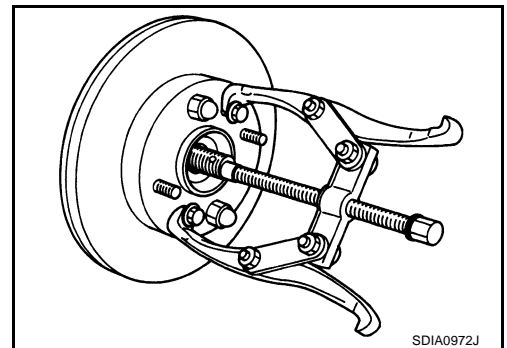

### INSPECTION AFTER REMOVAL

- Move joint up/down, left/right, and in the axial direction. Check for any rough movement or significant looseness.
- Check boot for cracks or other damage, and also for grease leakage.
- If a trouble is found, disassemble drive shaft, and then replace with new one.

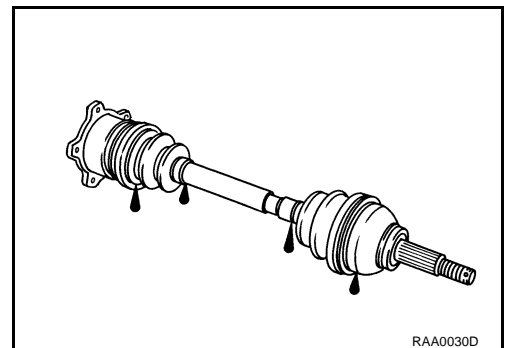

### INSTALLATION

Refer to [RAX-9, "Removal and Installation"](#) for tightening torque. Tighten in the reverse order of removal.

#### CAUTION:

Refer to component parts location and do not reuse non-reusable parts.

A  
B  
C  
RAX  
E  
F  
G  
H  
I  
J  
K  
L  
M

# REAR DRIVE SHAFT

EDS000WR

## Disassembly and Assembly

SEC.396

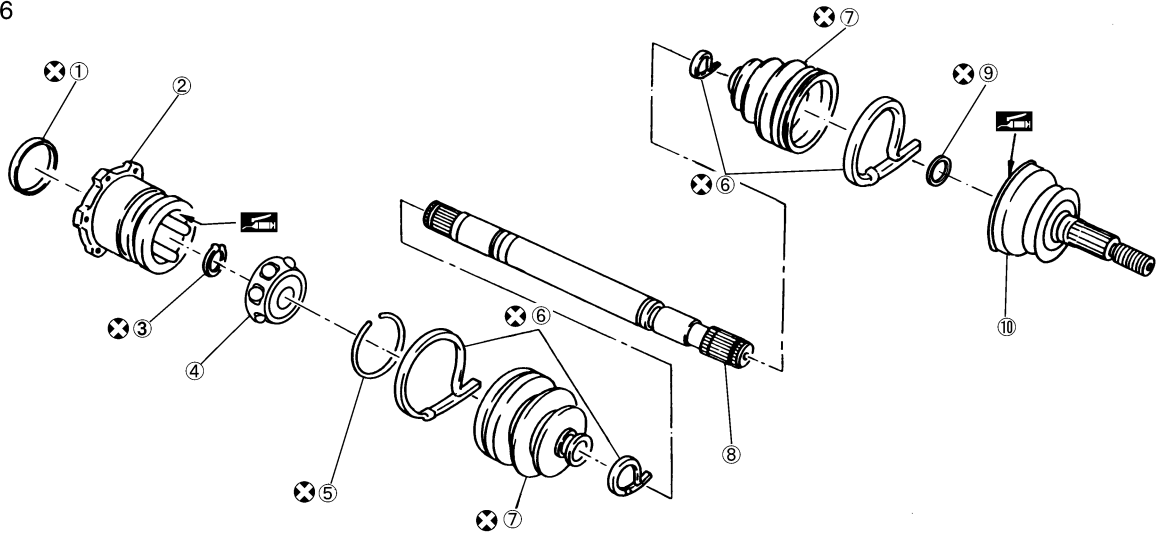

⊗: Always replace after every disassembly.

SDIA1488E

- |   |                 |                  |
|---|-----------------|------------------|
| 1. Plug                                     | 2. Housing      | 3. Snap ring     |
| 4. Ball cage/Steel ball/Inner race assembly | 5. Stopper ring | 6. Boot band     |
| 7. Boot                                     | 8. Shaft        | 9. Circular clip |
| 10. Joint sub-assembly                      |                 |                  |

### DISASSEMBLY

#### Final Drive Side

1. Press shaft in a vice.

#### CAUTION:

When retaining drive shaft in a vice, always use copper or aluminum plates between vise and shaft.

2. Remove boot bands.
3. If plug needs to be removed, move boot to wheel side, and drive it out with a plastic hammer.
4. Remove stopper ring with a flat-bladed screwdriver, and pull out housing.

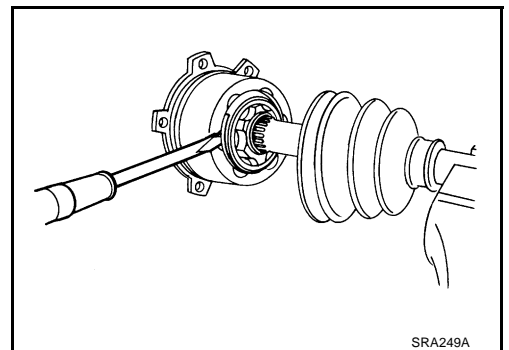

SRA249A

5. Remove snap ring, then remove ball cage/steel ball/inner race assembly from shaft.
6. Remove boot from shaft.
7. Remove old grease on housing with paper towels.

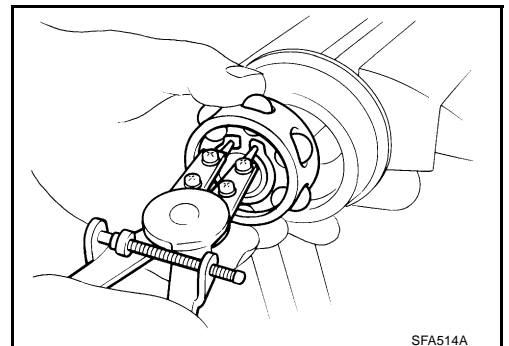

SFA514A

# REAR DRIVE SHAFT

## Wheel Side

1. Place shaft in a vice.

### CAUTION:

When retaining drive shaft in a vice, always use copper or aluminium plates between vise and shaft.

2. Remove boot bands. Then remove boot from joint sub-assembly.
3. Screw a drive shaft puller 30 mm (1.18 in) or more into threaded part of joint sub-assembly. Pull joint sub-assembly out of shaft.

### CAUTION:

- If joint sub-assembly cannot be removed after five or more unsuccessful attempts, replace shaft and joint sub-assembly as a set.
- Align sliding hammer and drive shaft and remove them by pulling directly.

4. Remove boot from shaft.
5. Remove circular clip from shaft.
6. While rotating ball cage, remove old grease on joint sub-assembly with paper towels.

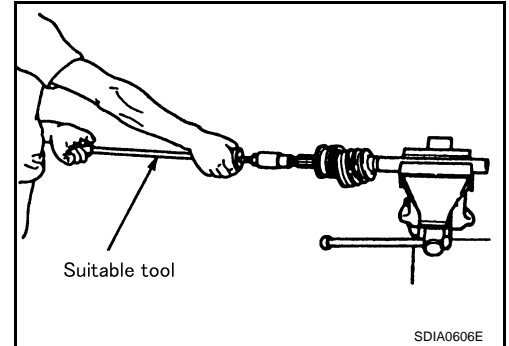

## INSPECTION AFTER DISASSEMBLY

### Shaft

Replace shaft if there is any runout, cracking, or other damage.

### Joint Sub-assembly

- Make sure there is no rough rotation or unusual axial looseness.
- Make sure there is no foreign material inside joint.
- Check joint sub-assembly for compression scar, cracks, or fractures.

### CAUTION:

If there are any irregular conditions of joint sub-assembly components, replace the entire joint sub-assembly.

### Sliding Joint Side (Housing)

- Make sure there are no compression scars, cracks, fractures or unusual wear of ball rolling surface.
- Make sure there is no damage to shaft screws.
- Make sure there is no deformation of boot installation parts.

### Ball Cage

Make sure there are no compression scars, cracks, fractures of sliding surface.

### Steel Ball

Make sure there are no compression scars, cracks, fractures or unusual wear.

### Inner Race

- Check ball sliding surface for compression scars, cracks, fractures.
- Make sure there is no damage to serrated part.

### CAUTION:

If there are any irregular conditions in the component, replace with a new set of housing, ball cage, steel ball, inner race.

# REAR DRIVE SHAFT

## ASSEMBLY

### Final Drive Side

1. If plug has been removed, use a drift (SST) to press in a new one.

**NOTE:**

Discard old plug; replace with new one.

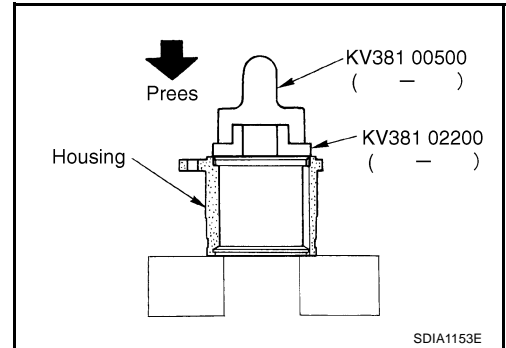

2. Wind serrated part of shaft with tape. Install boot band and boot to shaft. Be careful not to damage boot.

**NOTE:**

Discard old boot band and boot; replace with each new one.

3. Remove protective tape wound around serrated part of shaft.

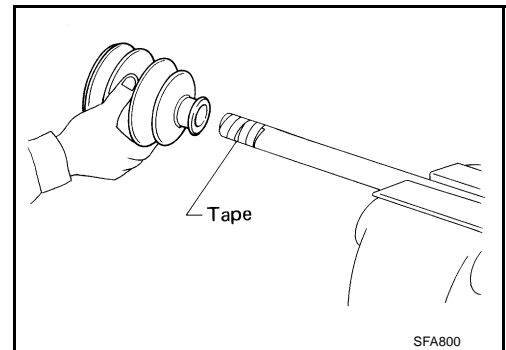

4. Install ball cage/steel ball/inner race assembly to shaft, and secure them tightly with a snap ring.

**NOTE:**

Discard old snap ring; replace with new one.

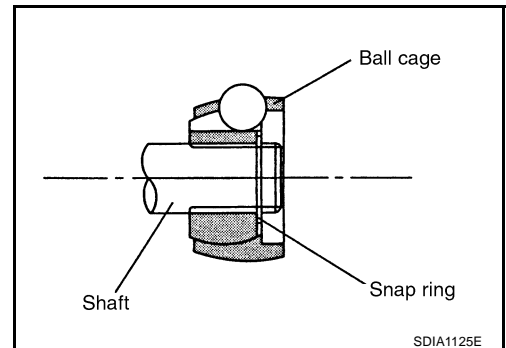

5. Insert the amount grease (NISSAN genuine grease or equivalent) onto housing (\* point) to the quantity mentioned below, and install it to shaft.

**Grease amount : 124 - 134 g (4.37 - 4.73 oz)**

6. Install stopper ring to housing.
7. After installed, pull shaft to check engagement between joint sub-assembly and stopper ring.

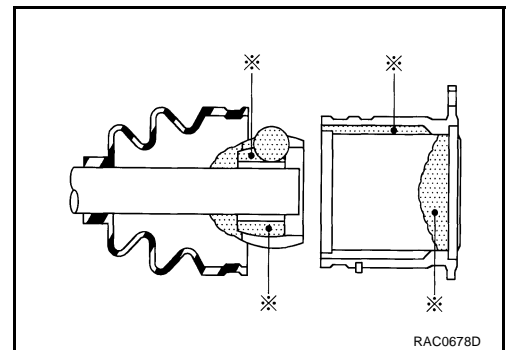

## REAR DRIVE SHAFT

8. Install boot securely into grooves (indicated by \* marks) shown in the figure.

**CAUTION:**

If there is grease on boot mounting surfaces (indicated by\* marks) of shaft and housing, boot may come off. Remove all grease from surfaces.

9. Make sure boot installation length "L" is the length indicated below. Insert a flat-bladed screwdriver or similar tool into smaller side of boot. Bleed air from boot to prevent boot deformation.

**Boot installation Length "L" : 93.9 mm (3.697 in)**

**CAUTION:**

- Boot may break if boot installation length is than standard value.
- Take care not to touch the tip of screwdriver to inside of boot.

10. Secure big and small ends of boot with new boot bands as shown in the figure.

**NOTE:**

Discard old boot bands; replace with new ones.

11. After installing housing and shaft, rotate boot to check whether or not the actual position is correct. If boot position is not correct, secure boot with new boot band again.

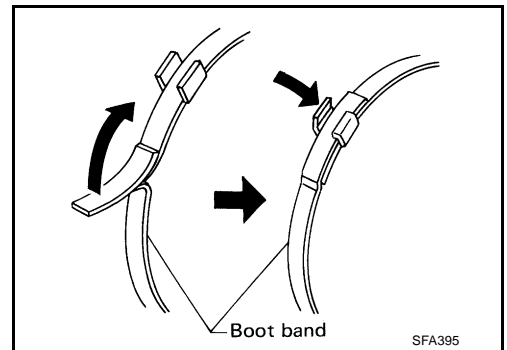
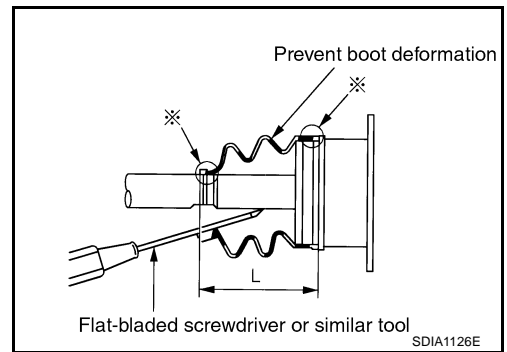

### Wheel Side

1. Insert the amount grease (NISSAN genuine grease or equivalent) into joint sub-assembly serration hole until grease begins to ooze from ball groove and serration hole. After insert grease, use a shop cloth to wipe off old grease that has oozed out.

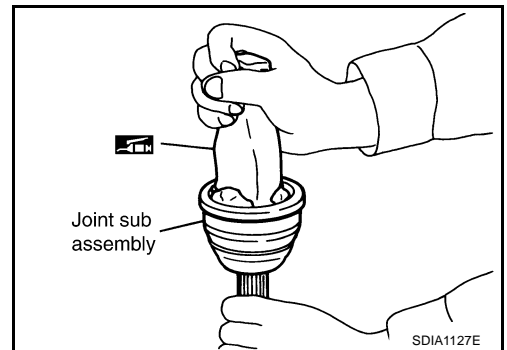

2. Wind serrated part of shaft with tape. Install boot band and boot to shaft. Be careful not to damage boot.

**NOTE:**

Discard old boot band and boot; replace with new ones.

3. Remove protective tape wound around serrated part of shaft.

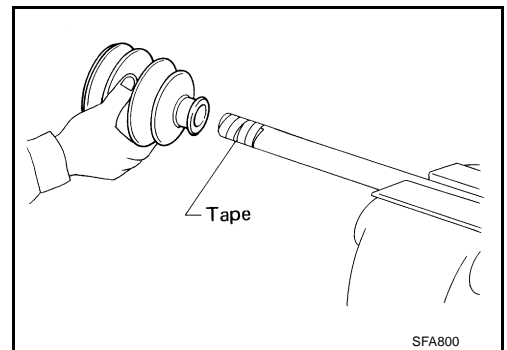

## REAR DRIVE SHAFT

- Attach circular clip to shaft. At this time, circular clip must fit securely into shaft groove. Attach nut to joint sub-assembly.

**NOTE:**

Discard old circular clip; replace with new one.

- Insert the amount grease (NISSAN genuine grease or equivalent) listed below into housing from large end of boot.

**Grease amount : 86 - 96 g (3.03 - 3.39 oz)**

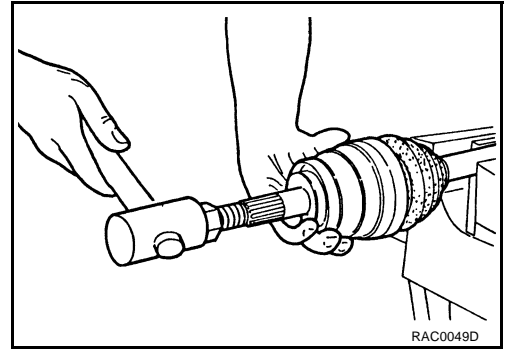

- Install boot securely into grooves (indicated by \* marks) shown in the figure.

**CAUTION:**

**If there is grease on boot mounting surfaces (indicated by \* marks) of shaft and housing, boot may come off. Remove all grease from surfaces.**

- Make sure boot installation length "L" is the length indicated below. Insert a flat-bladed screwdriver or similar tool into smaller side of boot. Bleed air from boot to prevent boot deformation.

**Boot installation length "L" : 97 mm (3.82 in)**

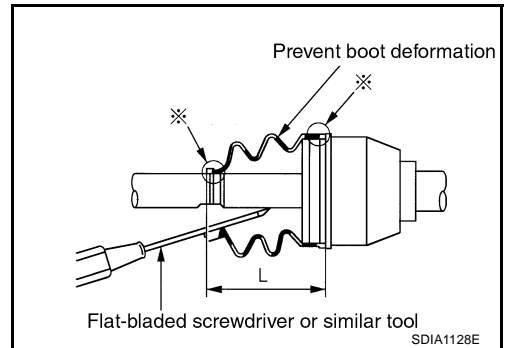

**CAUTION:**

- **Boot may brake if boot installation length is less than standard value.**
- **Be careful that screwdriver tip do not contact inside surface of boot.**

- Secure big and small ends of boot with new boot bands as shown in the figure.

**NOTE:**

Discard old boot bands; replace with new ones.

- After installing joint sub-assembly and shaft, rotate boot to check whether or not the actual position is correct. If boot position is not correct, secure boot with new boot bands again.

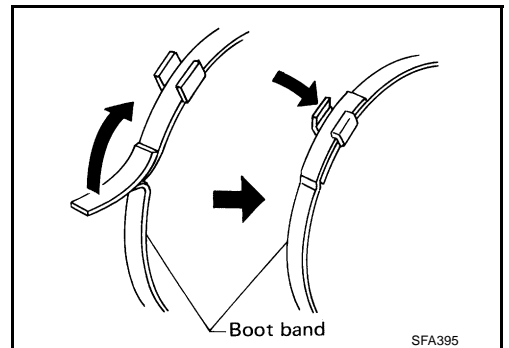

# SERVICE DATA

## SERVICE DATA

PFP:00030

### Wheel Bearing

EDS000WS

Axial end play	0.05 mm (0.002 in) or less
Rotating torque	At a load of 49, 033 N (5, 000 kg, 11, 000 lb) Less than 1.49 N-m (0.15 kg-m, 13 in-lb)
Measurement of spring scale	Less than 12.8 N (1.31 kg, 2.88 lb)

Measuring point (Brake caliper installation points)

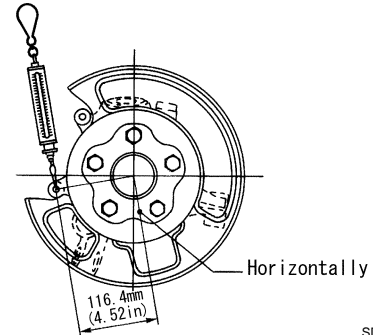

SDIA0293E

### Drive Shaft

EDS000WT

Joint type	Wheel side	Final drive side
Grease quantity	86 - 96 g (3.03 - 3.39 oz)	124 - 134 g (4.37 - 4.73 oz)
Boots installed length	97 mm (3.82 in)	93.9 mm (3.697 in)

### Tightening Torque

EDS000WU

Drive shaft - Side flange	63 - 79 N-m (6.5 - 8.0 kg-m, 47 - 58 ft-lb)
Hub lock nut	206 - 274 N-m (21 - 27 kg-m, 152 - 202 ft-lb)

A  
B  
C  
RAX  
E  
F  
G  
H  
I  
J  
K  
L  
M

## SERVICE DATA

---