

SECTION **FAX**
FRONT AXLE

A
B
C

FAX

CONTENTS

E

PREPARATION	2	WHEEL BEARING INSPECTION	4	F
Special Service Tools (SST)	2	Removal and Installation	4	
Commercial Service Tools	2	REMOVAL	4	
NOISE, VIBRATION AND HARSHNESS (NVH)		INSPECTION AFTER REMOVAL	5	G
TROUBLESHOOTING	3	INSTALLATION	5	
NVH Troubleshooting Chart	3	SERVICE DATA	7	
FRONT WHEEL HUB AND KNUCKLE	4	Wheel Bearing	7	H
On-Vehicle Inspection and Service	4			

I

J

K

L

M

PREPARATION

PFP:00002

PREPARATION

Special Service Tools (SST)

EDS000WC

The actual shapes of Kent-Moore tools may differ from those of special service tools illustrated here.

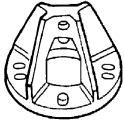
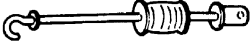
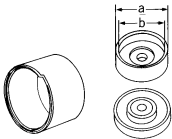
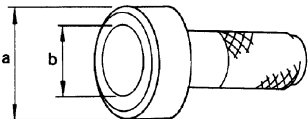
Tool number (Kent-Moore No.) Tool name	Description
KV40104100 (—) Attachment	 <p style="text-align: center;">ZZA0804D</p>
ST36230000 (J25840-A) Sliding hammer	 <p style="text-align: center;">ZZA0803D</p>
KV40105220 (—) Drift a:75 mm (2.95 in) dia. b:62 mm (2.44 in) dia.	 <p style="text-align: center;">ZZA1101D</p>
KV38100500 (—) Drift a:80 mm (3.15 in) dia. b:60 mm (2.36 in) dia.	 <p style="text-align: center;">ZZA0701D</p>

Commercial Service Tools

EDS000WD

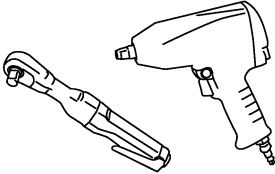
Tool name	Description
Power tool	 <p style="text-align: center;">PBIC0190E</p> <ul style="list-style-type: none"> ● Removing wheel nuts ● Removing brake caliper assembly

NOISE, VIBRATION AND HARSHNESS (NVH) TROUBLESHOOTING

NOISE, VIBRATION AND HARSHNESS (NVH) TROUBLESHOOTING

PFP:00003

NVH Troubleshooting Chart

EDS000WE

Use chart below to help you find the cause of the symptom. If necessary, repair or replace these parts.

Reference page			FAX-4	-	FAX-4	NVH in WT section.	NVH in WT section.	NVH in PS section.
Possible cause and SUSPECTED PARTS			Improper installation, looseness	Parts interference	Wheel bearing damage	TIRES	ROAD WHEELS	STEERING
Symptom	FRONT AXLE	Noise	x	x		x	x	x
		Shake	x	x		x	x	x
		Vibration	x	x		x		x
		Shimmy	x	x		x	x	x
		Judder	x			x	x	x
		Poor quality ride or handling	x	x	x	x	x	

x: Applicable

A
B
C
FAX
E
F
G
H
I
J
K
L
M

FRONT WHEEL HUB AND KNUCKLE

FRONT WHEEL HUB AND KNUCKLE

PFP:40202

On-Vehicle Inspection and Service

EDS000WF

Make sure the mounting conditions (looseness, backlash) of each component and component conditions (wear, damage) are normal.

WHEEL BEARING INSPECTION

- Move wheel hub and bearing assembly in the axial direction by hand. Make sure there is no looseness of wheel bearing.

Axial end play : 0.05 mm (0.002 in) or less

- Rotate wheel hub and make sure there are no unusual noises or other irregular condition. If there are any irregular conditions, replace wheel hub and bearing assembly.

Removal and Installation

EDS000WG

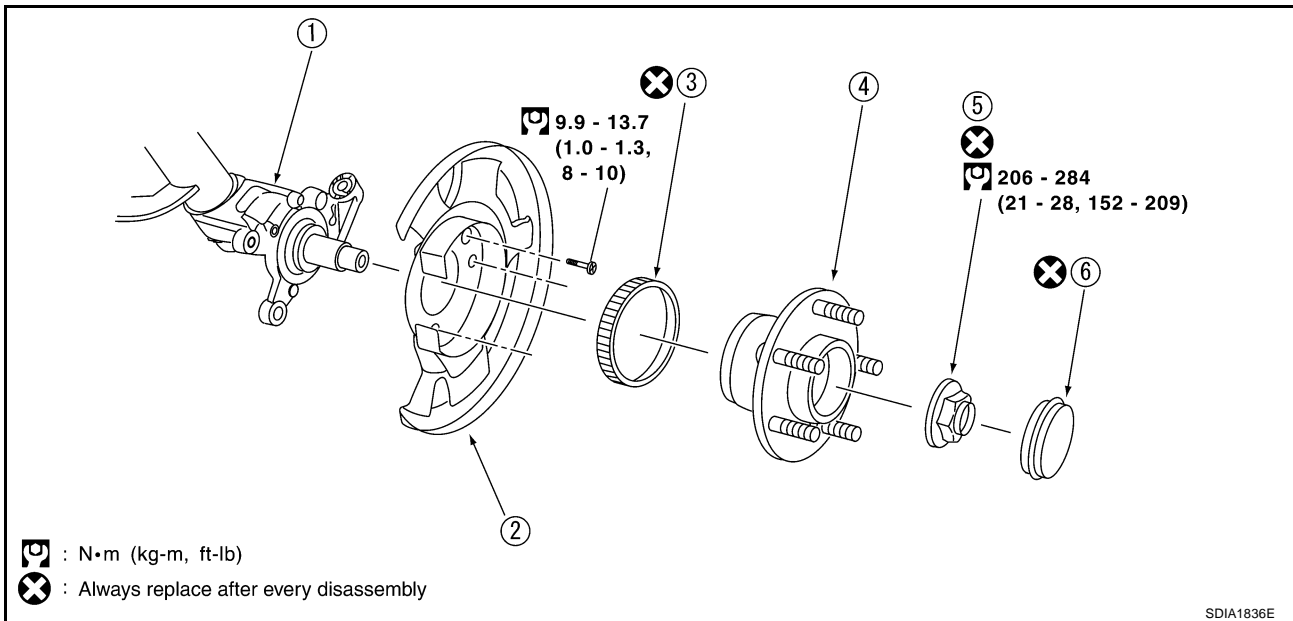

1. Strut assembly
2. Splash guard
3. Sensor rotor
4. Wheel hub and bearing assembly
5. Lock nut
6. Hub cap

REMOVAL

1. Remove tire from vehicle with a power tool.
2. Remove brake caliper with a power tool. Hang it in a place where it will not interfere with work. Refer to [BR-23, "FRONT DISC BRAKE"](#).

NOTE:

Avoid depressing brake pedal while brake caliper is removed.

3. Use a hub cap pliers (suitable tool) to remove hub cap from wheel hub and bearing assembly.
4. Pull up caulked area of lock nut with a flat-bladed screwdriver.

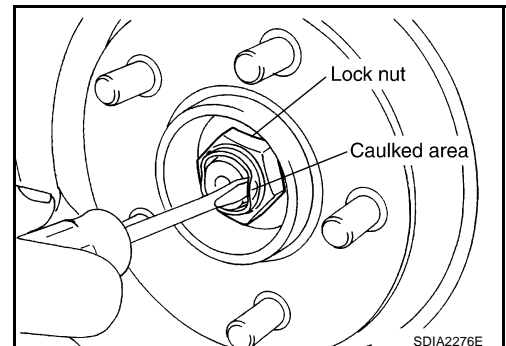

FRONT WHEEL HUB AND KNUCKLE

- Put alignment marks on disc rotor and wheel hub and bearing assembly.
- Remove disc rotor.

NOTE:

If it is difficult to remove disc rotor, remove it by tapping with rubber hammer.

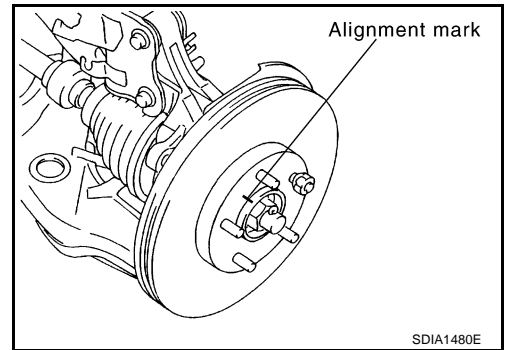

- Remove lock nut, then remove wheel hub and bearing assembly from strut assembly.

- When it is hard to remove wheel hub and bearing assembly from strut assembly due to burnout, use the attachment (SST) and sliding hammer (SST) for removal.

- Remove fixing screws of splash guard, then remove splash guard from strut assembly.

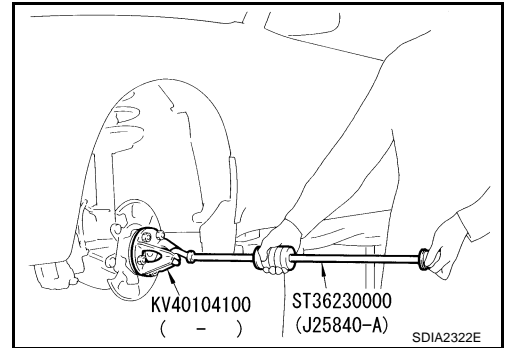

- As shown in the figure, using a puller (suitable tool) and drift (SST) to remove wheel hub and bearing assembly from sensor rotor.

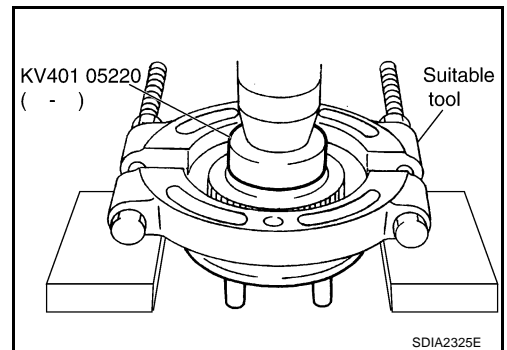

INSPECTION AFTER REMOVAL

Check for deformity, cracks and damage on each parts, replace if there are.

INSTALLATION

- Refer to [FAX-4, "Removal and Installation"](#) for tightening torque. Install in the reverse order of the removal.

NOTE:

Refer to component parts location and do not reuse non-reusable parts.

- Install hub cap using the drift (SST).

NOTE:

Do not reuse hub cap.

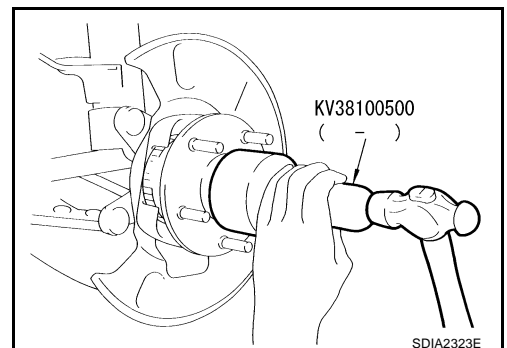

A
B
C
FAX
E
F
G
H
I
J
K
L
M

FRONT WHEEL HUB AND KNUCKLE

- Press-fit sensor rotor into wheel hub and bearing assembly using a drift (suitable tool).

NOTE:

- Do not reuse sensor rotor.
 - Sensor rotor must be installed with its grooved side facing inboard.
- After installation of lock nut, be sure to perform clinching. Refer to figure for clinching procedure.
 - After removing/installing or replacing axle components, check wheel alignment. Refer to [FSU-5, "Wheel Alignment Inspection"](#).
 - After adjusting wheel alignment, adjust neutral position of steering angle sensor. Refer to [BRC-6, "Adjustment of Steering Angle Sensor Neutral Position"](#).

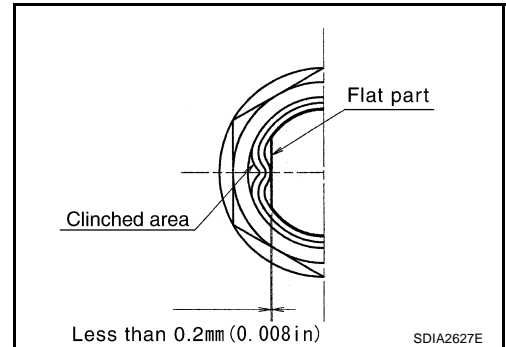
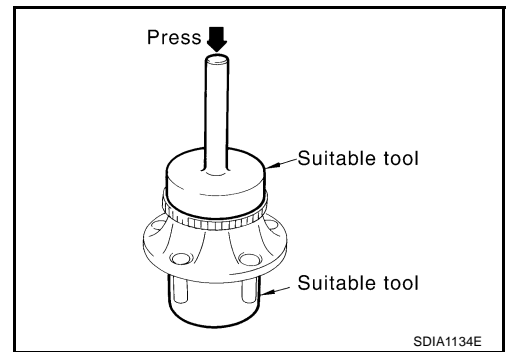

SERVICE DATA

SERVICE DATA

PFP:00030

Wheel Bearing

EDS000WI

A

B

C

FAX

E

F

G

H

I

J

K

L

M

Axial end play

0.05 mm (0.002 in) or less

SERVICE DATA
