

A
B
C
D
E

SECTION **BR** BRAKE SYSTEM

CONTENTS

<p>PRECAUTIONS 3</p> <p style="padding-left: 20px;">Precautions for Supplemental Restraint System (SRS) "AIR BAG" and "SEAT BELT PRE-TENSIONER" 3</p> <p style="padding-left: 20px;">Precautions for Brake System 3</p> <p>PREPARATION 4</p> <p style="padding-left: 20px;">Commercial Service Tools 4</p> <p>NOISE, VIBRATION AND HARSHNESS (NVH)</p> <p>TROUBLESHOOTING 5</p> <p style="padding-left: 20px;">NVH Troubleshooting Chart 5</p> <p>BRAKE PEDAL 6</p> <p style="padding-left: 20px;">Inspection and Adjustment 6</p> <p style="padding-left: 40px;">PLAY AND CLEARANCE BETWEEN BRAKE PEDAL AND FLOOR PANEL WITH PEDAL DEPRESSED 6</p> <p style="padding-left: 40px;">ADJUSTMENT 7</p> <p style="padding-left: 20px;">Components 7</p> <p style="padding-left: 20px;">Removal and Installation 8</p> <p style="padding-left: 40px;">REMOVAL 8</p> <p style="padding-left: 40px;">INSPECTION AFTER REMOVAL 8</p> <p style="padding-left: 40px;">INSTALLATION 8</p> <p>BRAKE FLUID 9</p> <p style="padding-left: 20px;">Checking Brake Fluid Level 9</p> <p style="padding-left: 20px;">Drain and Refill 9</p> <p style="padding-left: 20px;">Bleeding Brake System 9</p> <p>BRAKE TUBE AND HOSE 10</p> <p style="padding-left: 20px;">Hydraulic Circuit 10</p> <p style="padding-left: 20px;">Removal and Installation of Front Brake Tube and Hose 11</p> <p style="padding-left: 40px;">REMOVAL 11</p> <p style="padding-left: 40px;">INSTALLATION 11</p> <p style="padding-left: 20px;">Removal and Installation of Rear Brake Tube and Hose 11</p> <p style="padding-left: 40px;">REMOVAL 11</p> <p style="padding-left: 40px;">INSTALLATION 12</p> <p style="padding-left: 20px;">Inspection after Installation 12</p> <p>BRAKE MASTER CYLINDER 13</p> <p style="padding-left: 20px;">On-Vehicle Inspection 13</p> <p style="padding-left: 40px;">LEAK INSPECTION 13</p> <p style="padding-left: 20px;">Removal and Installation 13</p>	<p style="padding-left: 20px;">REMOVAL 13</p> <p style="padding-left: 20px;">INSTALLATION 13</p> <p style="padding-left: 20px;">Components 14</p> <p style="padding-left: 20px;">Disassembly and Assembly 14</p> <p style="padding-left: 40px;">DISASSEMBLY 14</p> <p style="padding-left: 40px;">INSPECTION AFTER DISASSEMBLY 16</p> <p style="padding-left: 40px;">ASSEMBLY 16</p> <p>BRAKE BOOSTER 20</p> <p style="padding-left: 20px;">On-Vehicle Inspection 20</p> <p style="padding-left: 40px;">OPERATING CHECK 20</p> <p style="padding-left: 40px;">AIRTIGHT CHECK 20</p> <p style="padding-left: 20px;">Components 20</p> <p style="padding-left: 20px;">Removal and Installation 21</p> <p style="padding-left: 40px;">REMOVAL 21</p> <p style="padding-left: 40px;">INSPECTION AFTER REMOVAL 21</p> <p style="padding-left: 40px;">INSTALLATION 21</p> <p>VACUUM LINES 22</p> <p style="padding-left: 20px;">Components 22</p> <p style="padding-left: 20px;">Removal and Installation 22</p> <p style="padding-left: 20px;">Inspection 22</p> <p style="padding-left: 40px;">VISUAL INSPECTION 22</p> <p style="padding-left: 40px;">CHECK VALVE INSPECTION 22</p> <p>FRONT DISC BRAKE 23</p> <p style="padding-left: 20px;">On-Vehicle Inspection 23</p> <p style="padding-left: 40px;">PAD WEAR INSPECTION 23</p> <p style="padding-left: 20px;">Components 23</p> <p style="padding-left: 20px;">Removal and Installation of Brake Pad 24</p> <p style="padding-left: 40px;">REMOVAL 24</p> <p style="padding-left: 40px;">INSTALLATION 25</p> <p style="padding-left: 20px;">Removal and Installation of Brake Caliper Assembly</p> <p style="padding-left: 40px;">... 25</p> <p style="padding-left: 40px;">REMOVAL 25</p> <p style="padding-left: 40px;">INSTALLATION 25</p> <p style="padding-left: 20px;">Disassembly and Assembly of Brake Caliper Assembly 26</p> <p style="padding-left: 40px;">DISASSEMBLY 26</p> <p style="padding-left: 40px;">INSPECTION AFTER DISASSEMBLY 26</p> <p style="padding-left: 40px;">ASSEMBLY 27</p> <p style="padding-left: 40px;">DISC ROTOR INSPECTION 28</p> <p style="padding-left: 20px;">Brake Burnishing Procedure 28</p>
--	---

BR

G
H
I
J
K
L
M

REAR DISC BRAKE	29	DISASSEMBLY	31
On-Vehicle Inspection	29	INSPECTION AFTER DISASSEMBLY	32
PAD WEAR INSPECTION	29	ASSEMBLY	32
Components	29	DISC ROTOR INSPECTION	33
Removal and Installation of Brake Pad	30	Brake Burnishing Procedure	34
REMOVAL	30	SERVICE DATA AND SPECIFICATIONS (SDS)	35
INSTALLATION	30	General Specifications	35
Removal and Installation of Brake Caliper Assembly		Brake Pedal	35
... ..	31	Check Valve	35
REMOVAL	31	Brake Booster	35
INSTALLATION	31	Front Disc Brake	35
Disassembly and Assembly of Brake Caliper		Rear Disc Brake	35
Assembly	31		

PRECAUTIONS

PRECAUTIONS

PFP:00001

Precautions for Supplemental Restraint System (SRS) “AIR BAG” and “SEAT BELT PRE-TENSIONER”

NFS000B4

The Supplemental Restraint System such as “AIR BAG” and “SEAT BELT PRE-TENSIONER”, used along with a front seat belt, helps to reduce the risk or severity of injury to the driver and front passenger for certain types of collision. This system includes seat belt switch inputs and dual stage front air bag modules. The SRS system uses the seat belt switches to determine the front air bag deployment, and may only deploy one front air bag, depending on the severity of a collision and whether the front occupants are belted or unbelted. Information necessary to service the system safely is included in the SRS and SB section of this Service Manual.

WARNING:

- To avoid rendering the SRS inoperative, which could increase the risk of personal injury or death in the event of a collision which would result in air bag inflation, all maintenance must be performed by an authorized NISSAN/INFINITI dealer.
- Improper maintenance, including incorrect removal and installation of the SRS, can lead to personal injury caused by unintentional activation of the system. For removal of Spiral Cable and Air Bag Module, see the SRS section.
- Do not use electrical test equipment on any circuit related to the SRS unless instructed to in this Service Manual. SRS wiring harnesses can be identified by yellow and/or orange harnesses or harness connectors.

Precautions for Brake System

NFS000B5

- Clean dust on front brake and rear brake with a vacuum dust collector. Do not blow with compressed air.
- Recommended fluid is brake fluid “DOT 3”. Refer to [MA-10, "Fluids and Lubricants"](#) .
- Do not reuse drained brake fluid.
- Be careful not to splash brake fluid on painted areas such as body. If brake fluid is splashed on painted areas, wipe it off and wash it away with water immediately.
- Use clean brake fluid to clean or wash all parts of master cylinder, disc brake caliper, etc.
- Do not use mineral oils such as gasoline or kerosene. They will ruin rubber parts of hydraulic system.
- Use a flare nut torque wrench when installing brake tube.
- When installing brake piping, be sure to check torque.
- Before working, turn ignition switch OFF and disconnect connector for VDC/TCS/ABS control unit or battery cables.
- Burnish brake pad (or lining) contact surfaces of disc rotor after refinishing or replacing drums or rotors, after replacing pads or linings, or if a soft pedal occurs at very low mileage. Refer to [BR-28, "Brake Burnishing Procedure"](#) (Front disc brake), [BR-34, "Brake Burnishing Procedure"](#) (Rear disc brake).

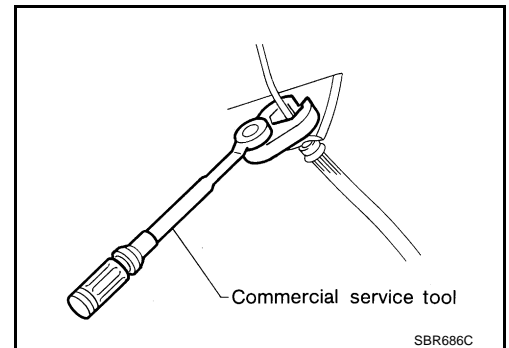

WARNING:

- Clean brake pads and shoes with a waste cloth, then wipe them with a vacuum dust collector.



PREPARATION

PREPARATION

PFP:00002

Commercial Service Tools

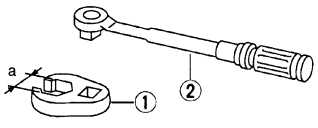
NFS000B6

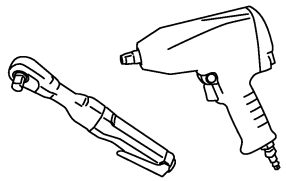
Tool name	Description
<p>1.Flare nut crowfoot a: 10 mm (0.39 in) / 12 mm (0.47 in) 2.Torque wrench</p>  <p>S-NT360</p>	<p>Installing each brake piping</p>
<p>Pin punch Tip diameter: ϕ 4 mm (0.16 in) dia.</p>  <p>ZZA0515D</p>	<p>Removing and installing reservoir tank pin</p>
<p>Power tool</p>  <p>PBIC0190E</p>	<p>Removing front and rear caliper assembly, tires</p>

NOISE, VIBRATION AND HARSHNESS (NVH) TROUBLESHOOTING

NOISE, VIBRATION AND HARSHNESS (NVH) TROUBLESHOOTING

PPF:00003

NVH Troubleshooting Chart

NFS000B7

Use the chart below to help you find the cause of the symptom. If necessary, repair or replace these parts.

Symptom		BRAKE	Possible cause and SUSPECTED PARTS														Reference page					
			Pads - damaged	Pads - uneven wear	Shims damaged	Rotor imbalance	Rotor damage	Rotor run out	Rotor deformation	Rotor deflection	Rotor rust	Rotor thickness variation	Drum out of round	PROPELLER SHAFT	DIFFERENTIAL	AXLE AND SUSPENSION		TIRES	ROAD WHEEL	DRIVE SHAFT	STEERING	
Noise	Shake	Shimmy, Judder	X	X	X																BR-23, BR-29	
						X								X								BR-23, BR-29
						X	X	X	X	X	X	X				X	X	X	X			
																					—	
																						—
																						BR-28, BR-33
																						—
																						BR-28, BR-33
																						—
																						NVH in PR section
																						NVH in RFD section
																						NVH in FAX, RAX and FSU, RSU section
																						NVH in WT section
																						NVH in WT section
																						NVH in RAX section
																						NVH in PS section

X: Applicable

A
B
C
D
E
BR
G
H
I
J
K
L
M

BRAKE PEDAL

BRAKE PEDAL

PFP:46501

Inspection and Adjustment

NFS000B8

PLAY AND CLEARANCE BETWEEN BRAKE PEDAL AND FLOOR PANEL WITH PEDAL DEPRESSED

- Check brake pedal play.
- Check brake pedal free height from dash lower panel.
- Adjust height referring to following specifications.

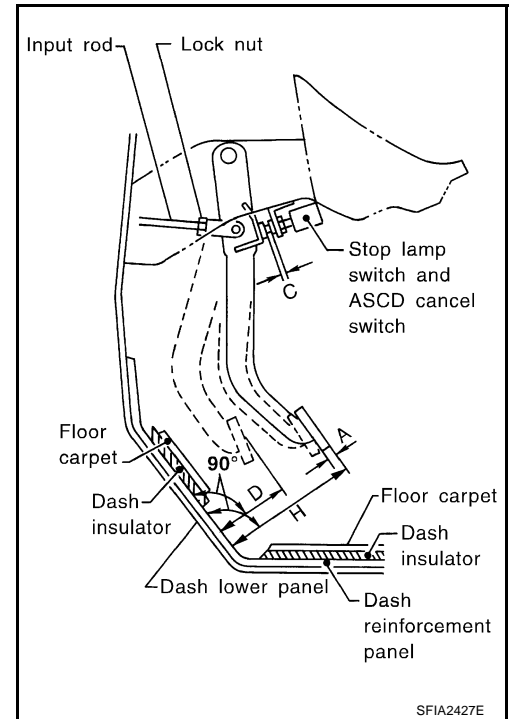

H	Brake pedal height (from dash lower panel top surface)	192.4 – 202.4 mm (7.57 – 7.97 in)
D	Depressed pedal height [under a force of 490 N (50 kg, 110 lb) with engine running]	90 mm (3.54 in) or more
C	Clearance between stopper rubber and threaded end of stop lamp switch and ASCD cancel switch.	0.74 – 1.96 mm (0.0291 – 0.0772 in)
A	Pedal play	3 – 11 mm (0.12 – 0.43 in)

BRAKE PEDAL

ADJUSTMENT

1. Loosen stop lamp switch and ASCD cancel switch by rotating it counterclockwise by 45°.
2. Loosen lock nut (A) on input rod to rotate input rod for adjusting brake pedal height to the specified one, and tighten lock nut (A). Refer to [BR-20, "Components"](#).

CAUTION:

Make sure the threaded end of input rod stays inside clevis.

3. With the pedal pulled and held by hand, press stop lamp switch and ASCD cancel switch until its threaded end contacts stopper rubber.
4. With the threaded end of stop lamp switch and ASCD cancel switch contacting the bracket, rotate switch clockwise by 45° to secure.

CAUTION:

Make sure that clearance (C) between stopper rubber and end of stop lamp switch and ASCD cancel switch is within the standard.

5. Check pedal play. Refer to [BR-6, "Inspection and Adjustment"](#).

CAUTION:

Make sure that stop lamps go off when pedal is released.

6. Start the engine to check brake pedal depression height when depressed. Refer to [BR-6, "Inspection and Adjustment"](#).

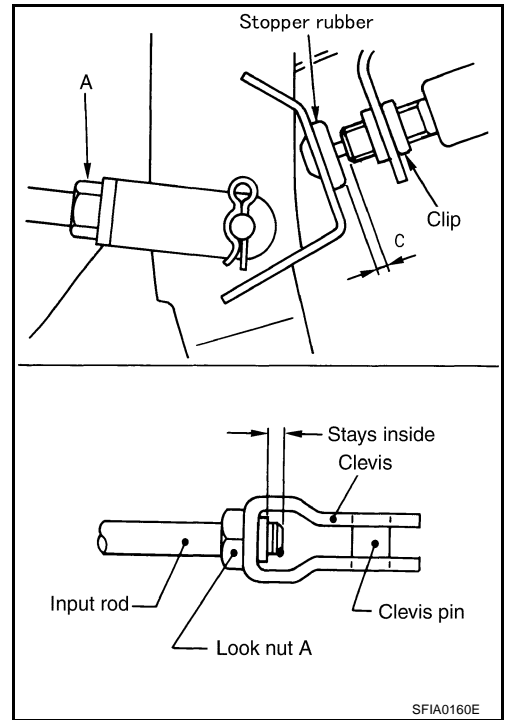

SFIA0160E

Components

NFS000HY

SEC.465

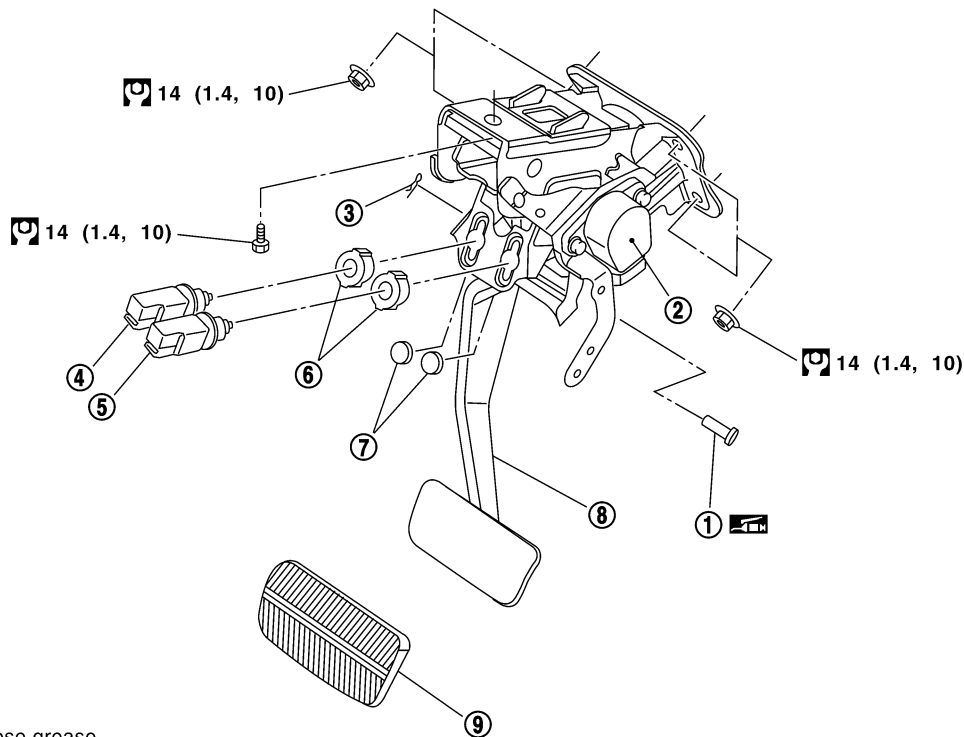

: Multi-purpose grease

: N·m (kg-m, ft-lb)

SFIA2469E

- | | | |
|-----------------------|------------------------------|--------------------|
| 1. Clevis pin | 2. Brake pedal stroke sensor | 3. Snap pin |
| 4. ASCD cancel switch | 5. Stop lamp switch | 6. Clip |
| 7. Stopper rubber | 8. Brake pedal assembly | 9. Brake pedal pad |

BRAKE PEDAL

NFS000B9

Removal and Installation

REMOVAL

1. Remove instrument lower driver panel. Refer to [IP-16, "\(V\) Instrument Lower Driver Panel"](#) .
2. Remove steering column. Refer to [PS-11, "STEERING COLUMN"](#) .
3. Remove stop lamp switch and ASCD cancel switch from brake pedal assembly.
4. Disconnect the brake pedal stroke sensor connector.

CAUTION:

Brake pedal stroke sensor is not detachable. Do not detach it.

5. Remove snap pin and clevis pin from brake booster clevis.
6. Remove mounting nuts and bolt from bracket, and remove brake pedal assembly from vehicle.

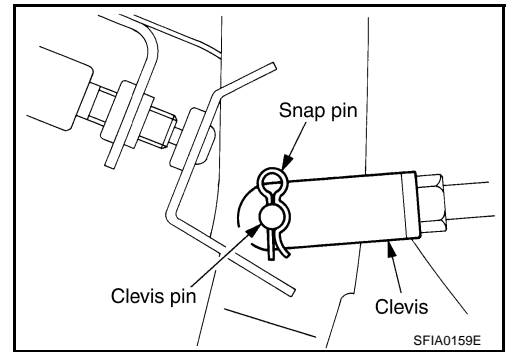

INSPECTION AFTER REMOVAL

- Check brake pedal upper rivet for deformation.
 - Make sure that the lapping length of sub-bracket and slide plate is at least 5 mm (0.20 in).
 - Check brake pedal for bend, damage, and cracks on the welded parts.
 - Replace brake pedal assembly if any non-standard condition is detected.
-
- Check clevis pin and plastic stopper for damage and deformation. Replace clevis pin if there are.

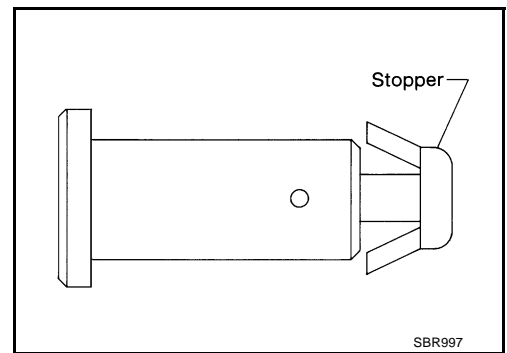
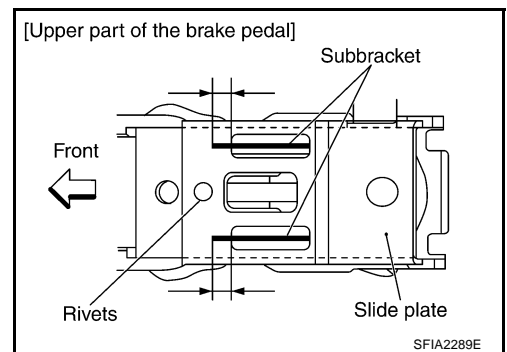

INSTALLATION

Paying attention to the following, install in the reverse order of the removal.

Tighten the mounting nuts and bolt to the specified torque. Refer to [BR-7, "Components"](#) .

- After installing brake pedal assembly to vehicle, adjust brake pedal. Refer to [BR-6, "Inspection and Adjustment"](#) .

BRAKE FLUID

BRAKE FLUID

PFP:KN100

Checking Brake Fluid Level

NFS000BA

- Make sure that a brake fluid level in reservoir tank is within the standard (between MAX and MIN lines).
- Visually check around reservoir tank for fluid leakage.
- If the level is excessively low, check brake system for leakage.
- Release parking brake pedal and see if brake warning lamp goes off. If not, check brake system for fluid leakage.

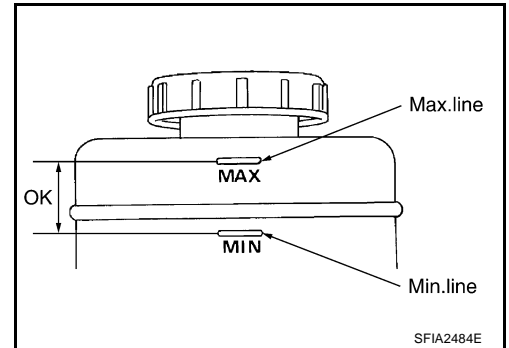

Drain and Refill

NFS000BB

CAUTION:

- Refill with new brake fluid "DOT3".
 - Do not reuse drained brake fluid.
 - Do not let brake fluid splash on painted surfaces of body. This might damage paint, so when splashing it on the surfaces, immediately wipe off them and wash it away with water.
 - Before servicing, disconnect electrical connectors of VDC/TCS/ABS control unit or battery cables.
1. Connect a vinyl tube to bleed valve.
 2. Depress brake pedal, loosen bleed valve, and gradually remove brake fluid.
 3. Make sure there is no foreign material in reservoir tank, and refill with new brake fluid.
 4. Rest foot on brake pedal. Loosen bleed valve. Slowly depress pedal until it stops. Tighten bleed valve. Release brake pedal. Repeat this process a few times, then pause to add new brake fluid to master cylinder. Continue until new brake fluid flows out.
 5. Bleed Air. Refer to [BR-9, "Bleeding Brake System"](#) .

Bleeding Brake System

NFS000BC

CAUTION:

- Carefully monitor brake fluid level in reservoir tank during bleeding operation.
- Refill with new brake fluid "DOT 3". Make sure it is at least half way at all times while bleeding air out of system.
- Place a container under master cylinder to avoid spillage of brake fluid.
- Turn ignition switch OFF and disconnect VDC actuator connectors or battery cables.

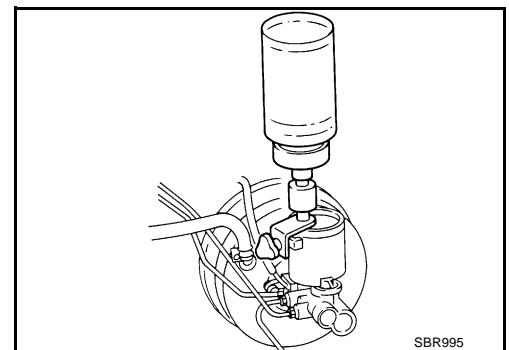

- Bleed air in the following order. Right rear brake → Left front brake → Left rear brake → Right front brake

1. Connect a transparent vinyl tube to bleed valve.
2. Fully depress brake pedal several times.
3. With brake pedal depressed, open bleed valve to release air.
4. Close bleed valve.
5. Release brake pedal slowly.
6. Repeat steps 2, through 5, until clear brake fluid comes out of bleed valve.

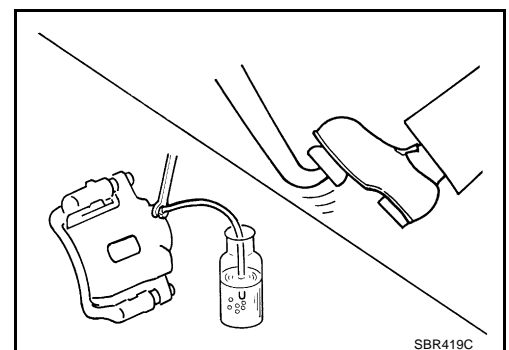

BRAKE TUBE AND HOSE

BRAKE TUBE AND HOSE

PFP:46300

Hydraulic Circuit

NFS000BD

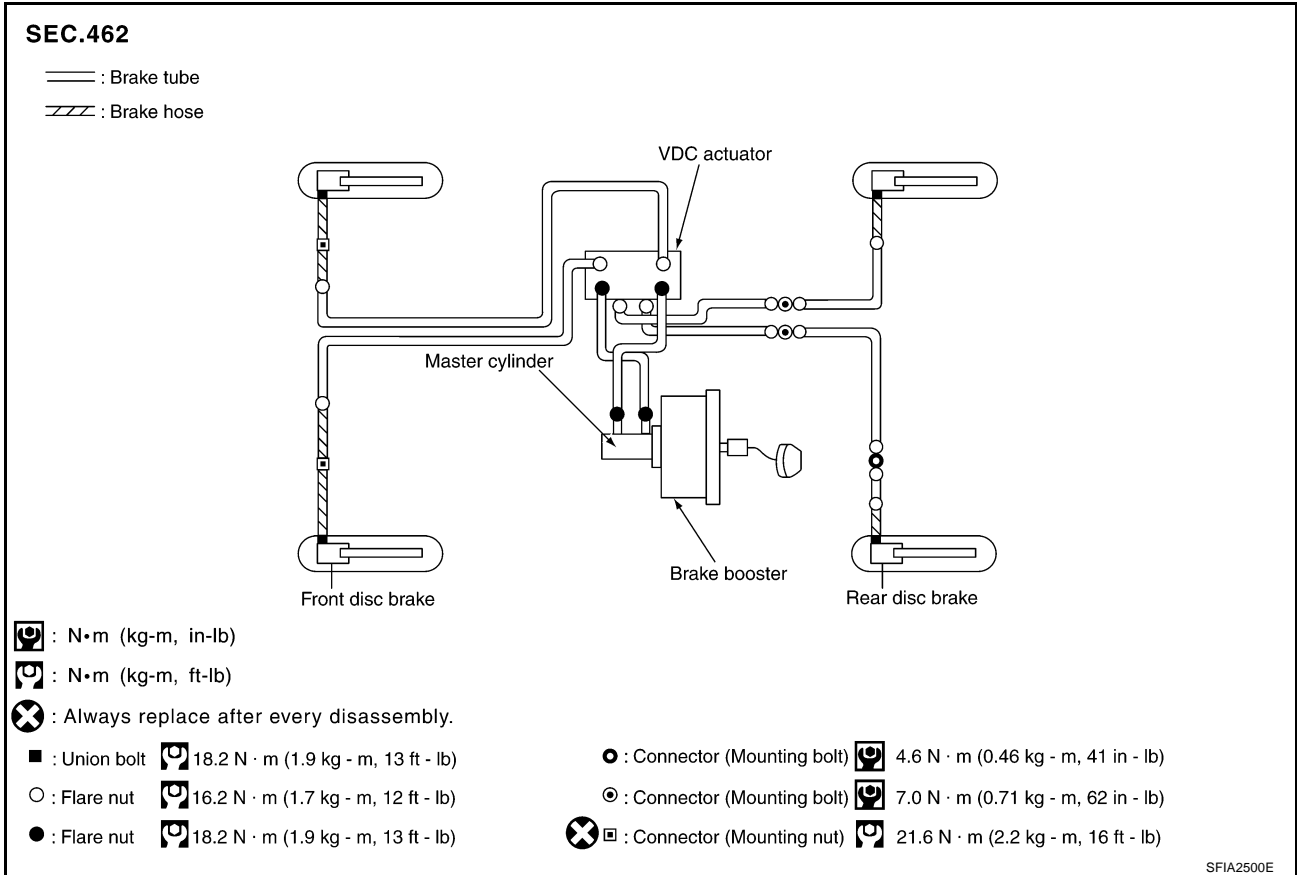

CAUTION:

- All hoses and piping (tubes) must be free from excessive bending, twisting and pulling.
- Make sure there is no interference with other parts when turning steering both clockwise and counterclockwise.
- The brake tubes and hoses are an important safety parts. If a brake fluid leak is detected, always disassemble the parts. Replace applicable part with a new one, if necessary.
- Be careful not to splash brake fluid on painted areas; it way cause paint damage. If brake fluid is splashed on painted surfaces of body, immediately wipe it off and then wash it away with water immediately.
- Do not bend or twist brake hose sharply, or strongly pull it.
- When removing components, cover brake line connections so that no dirt, dust, or other foreign matter gets in.
- Refill with new brake fluid “ DOT 3 ”
- Do not reuse drained brake fluid.

BRAKE TUBE AND HOSE

Removal and Installation of Front Brake Tube and Hose

NFS000BE

REMOVAL

1. Drain brake fluid. Refer to [BR-9, "Drain and Refill"](#) .
2. Cover brake line connections to prevent foreign material such as dust or dirt from entering into the connections.
3. Using a flare nut wrench, remove brake tube from brake hose. Remove union bolt, and remove brake hose from caliper assembly.
4. Remove lock plate.
5. Remove mounting nut, and remove brake hose from vehicle.

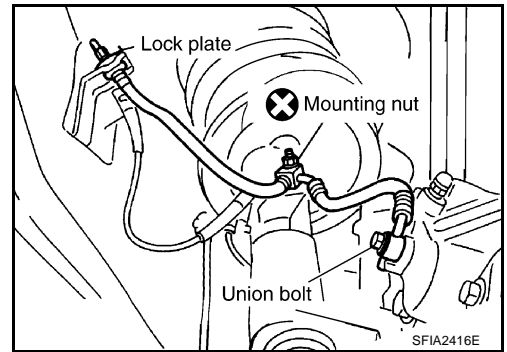

INSTALLATION

1. Position a metal fitting of brake hose between protrusions, and then tighten union bolt to the specified torque. Refer to [BR-10, "Hydraulic Circuit"](#) .

CAUTION:

Do not reuse the copper washer.

2. Connect brake hose to brake tube. Temporarily tighten flare nut by hand as much as possible. Secure them to bracket with the lock plate.
3. Tighten flare nut to the specified torque using a flare nut torque wrench. Refer to [BR-10, "Hydraulic Circuit"](#) .
4. Tighten mounting nuts to the specified torque. Refer to [BR-10, "Hydraulic Circuit"](#) .
5. After work, bleed air. Refer to [BR-9, "Bleeding Brake System"](#) .

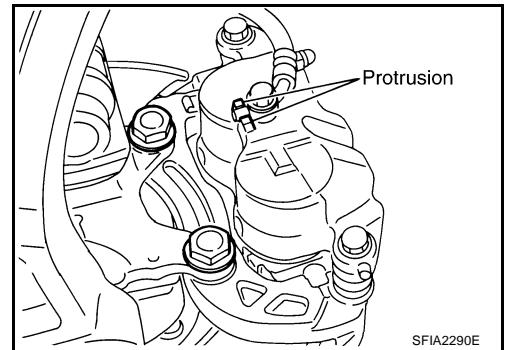

Removal and Installation of Rear Brake Tube and Hose

NFS000BF

REMOVAL

1. Drain brake fluid. Refer to [BR-10, "Hydraulic Circuit"](#) .
2. Cover brake line connections to prevent foreign material such as dust or dirt from entering into connections.
3. Using a flare nut wrench, remove brake tube from brake hose.
4. Remove union bolts, and then remove brake hose from caliper assembly.
5. Remove lock plate, and remove brake hose from vehicle.

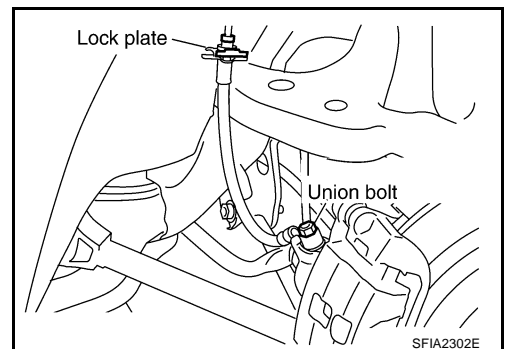

BRAKE TUBE AND HOSE

INSTALLATION

1. Install a projection of brake hose metal fitting by aligning with protrusions on caliper assembly, and then tighten union bolt to the specified torque. Refer to [BR-10, "Hydraulic Circuit"](#) .

CAUTION:

Do not reuse the copper washer.

2. Connect brake hose to brake tube. Temporarily tighten flare nut by hand as much as possible. Secure them to bracket with the lock plate.
3. Tighten flare nut to the specified torque using a flare nut torque wrench. Refer to [BR-10, "Hydraulic Circuit"](#) .
4. After work, bleed air. Refer to [BR-9, "Bleeding Brake System"](#) .

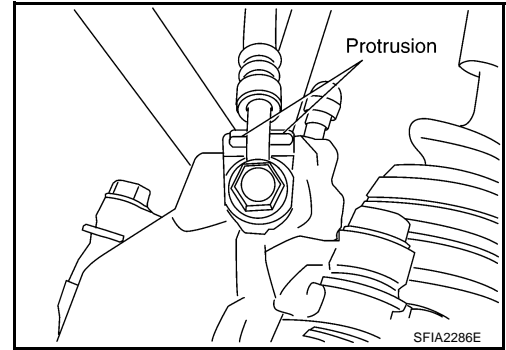

Inspection after Installation

NFS000BG

CAUTION:

If leak is detected at the connections, retighten it or replace damaged part if necessary.

1. Check hose, tube, and connections for fluid leakage, damage, twist, deformation, contact with other parts, and loose connections.
2. While depressing pedal under the force of 785 N (80 kg, 177 lb) with engine running for approximately 5 seconds, check for fluid leak from each part.

BRAKE MASTER CYLINDER

BRAKE MASTER CYLINDER

PFP:46010

On-Vehicle Inspection LEAK INSPECTION

NFS000BH

- Check for leaking in a master cylinder installation surface, a reservoir tank installation surface, and brake tube connections.

Removal and Installation REMOVAL

NFS000BI

1. Drain brake fluid. Refer to [BR-9, "Drain and Refill"](#) .
2. Remove harness connectors for the brake fluid level switch and pressure sensor (Models with ICC).
3. Using a flare nut wrench, remove brake tube from master cylinder.
4. Remove mounting nuts, and remove master cylinder assembly from vehicle.

INSTALLATION

CAUTION:

- Refill with new brake fluid "DOT 3".
 - Do not reuse the drained brake fluid.
1. Temporarily tighten the flare nuts on brake tube to master cylinder by hand.
 2. Install master cylinder to brake booster assembly, and tighten the mounting nuts to the specified torque. Refer to [BR-20, "Components"](#) .

CAUTION:

- Do not damage the sliding surface of the primary piston rod and do not allow foreign materials on it's surface.
- Do not reuse O-ring and primary piston.
- Apply PBC (Poly Butyl Cuprysil) grease or silicon-based grease or brake fluid for the O-ring and primary piston.

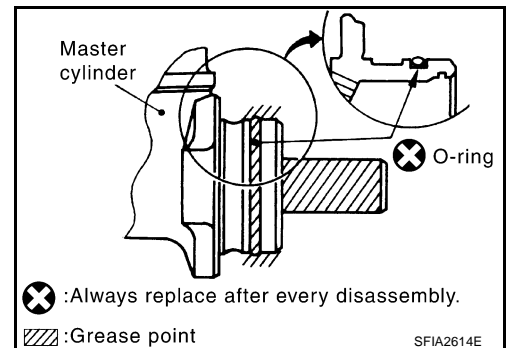

3. Using a flare nut torque wrench, tighten the flare nut on the brake tube to the specified torque. Refer to [BR-10, "Hydraulic Circuit"](#) .
4. Refill the new brake fluid and bleed air. Refer to [BR-9, "Bleeding Brake System"](#) .

BRAKE MASTER CYLINDER

Components

NFS000HZ

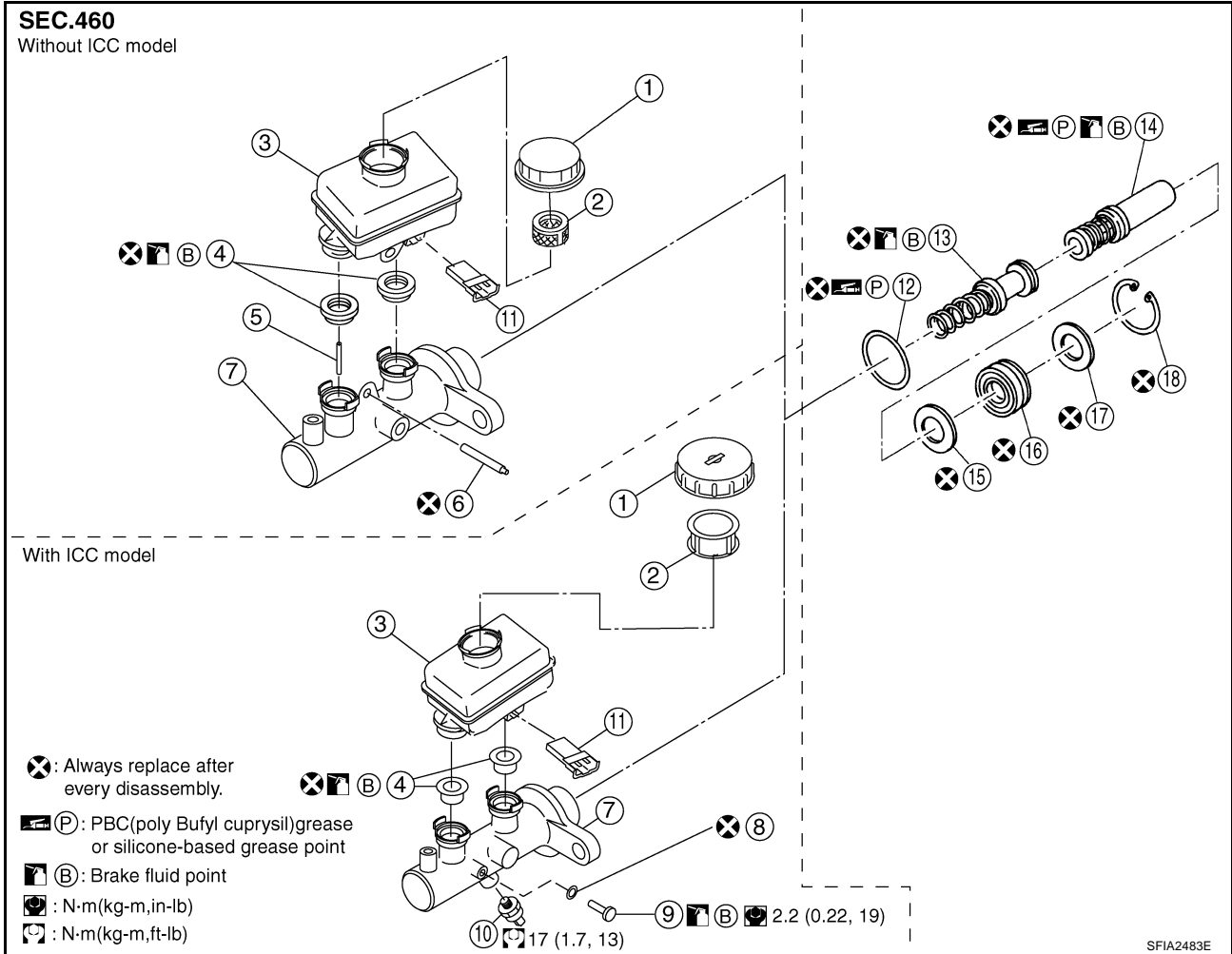

- | | | |
|-------------------------------|--|-------------------|
| 1. Reservoir cap | 2. Oil filter | 3. Reservoir tank |
| 4. Grommet | 5. Piston stopper | 6. Pin |
| 7. Cylinder body | 8. O-ring | 9. Piston stopper |
| 10. Pressure sensor | 11. Brake fluid level switch connector | 12. O-ring |
| 13. Secondary piston assembly | 14. Primary piston assembly | 15. Plate |
| 16. Guide assembly | 17. Plate (With ICC model only) | 18. Snap-ring |

Disassembly and Assembly

DISASSEMBLY

NFS000BJ

Models without ICC

1. Clamp the flange of the cylinder body in a vice in the figure.

CAUTION:

- Pay attention to the orientation of master cylinder body.
- Use the copper plate or closes for clamping the body in a vise.

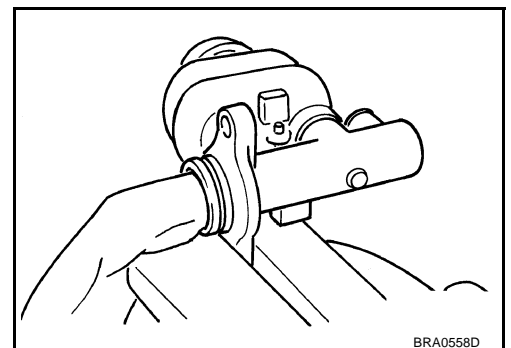

BRAKE MASTER CYLINDER

- Using the pin-punch [commercial service tool: approx. 4 mm (0.16 in) dia], remove pin from reservoir tank.
- Remove master cylinder assembly from a vise.
- Remove reservoir tank and grommet from cylinder body.

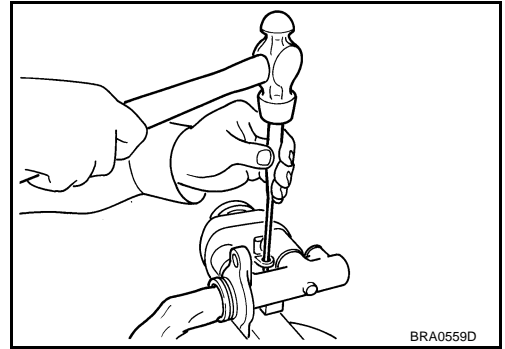

- Push primary piston assembly and remove piston stopper from cylinder body.

CAUTION:
Be careful not to damage the inner wall of cylinder body.

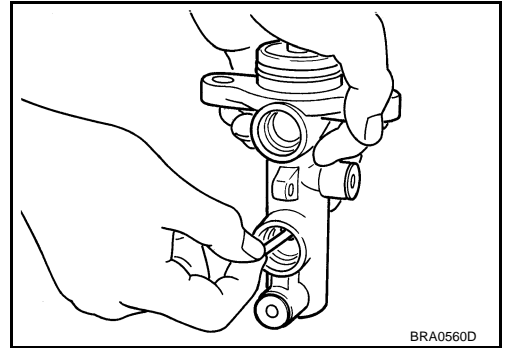

- Remove snap ring while pressing in primary piston assembly.

CAUTION:
Be careful not to put out the piston.

- Holding the rod of the primary piston, remove primary piston assembly, plate and guide with pulling straight to prevent cup from being caught by the inner wall of the cylinder.

- Remove plate and guide on primary piston.

CAUTION:
Be careful not to damage the rod from the inner wall of the plate.

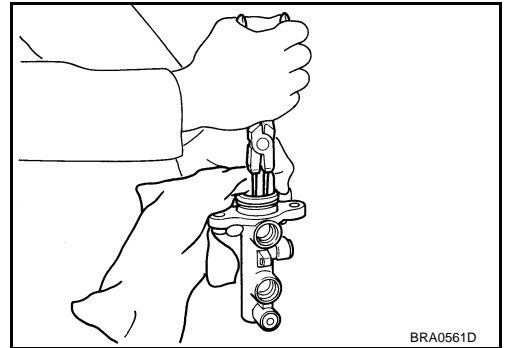

- Tap the flange of cylinder body using a soft block such as wood, and carefully pull the secondary piston assembly straight out to prevent the inner wall of the cylinder from being damaged.

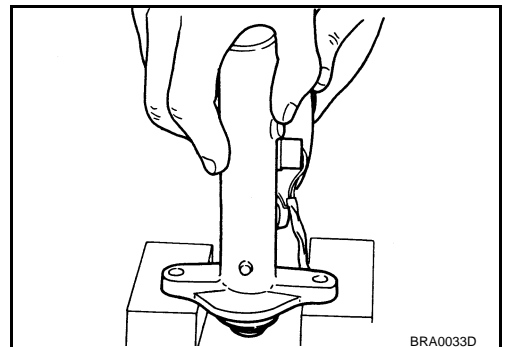

Models with ICC

CAUTION:
Be careful not to damage the rod of primary piston with covering cloths in acting.

A
B
C
D
E
BR
G
H
I
J
K
L
M

BRAKE MASTER CYLINDER

1. Clamp the flange of cylinder body in a vise in the figure.

CAUTION:

- Pay attention to the orientation of master cylinder body.
- Use the copper plate or closes for clamping the body in a vise.

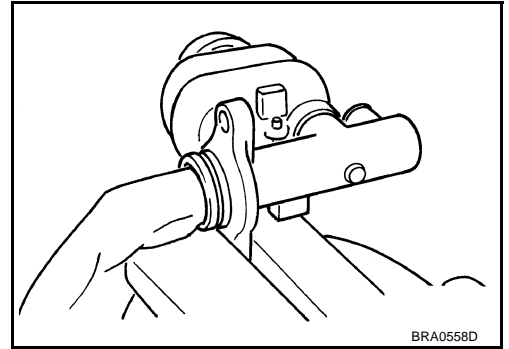

2. Push primary piston assembly and remove piston stopper from secondary tank boss hole in cylinder body.

CAUTION:

Be careful not to damage the inner wall of the cylinder.

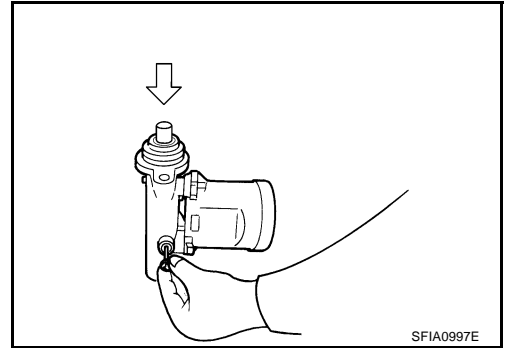

3. Remove snap ring while pressing in piston assembly.

CAUTION:

Be careful not to put out the piston.

4. Holding the rod of the primary piston, remove primary piston assembly, plate and the guide assembly with pulling straight to prevent cup from being caught by the inner wall of the cylinder.
5. Remove plate and guide assembly on primary piston assembly.

CAUTION:

Be careful not to damage the rod by the inner wall of the plate.

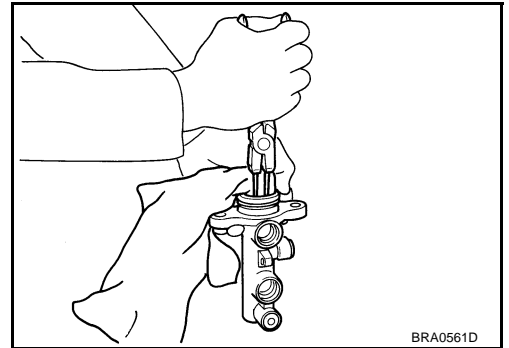

6. Tap the flange of cylinder body using a soft block such as wood, and carefully pull secondary piston assembly straight out to prevent the inner wall of the cylinder from being damaged.

7. Remove grommet and reservoir tank.

CAUTION:

Remove reservoir tank only when necessary.

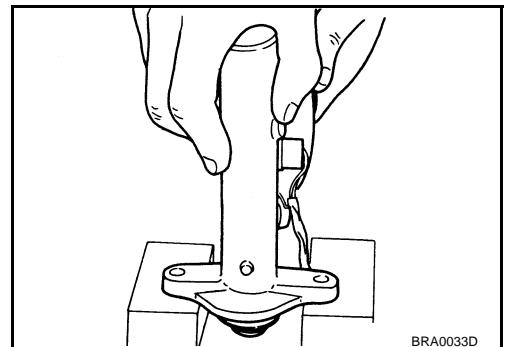

INSPECTION AFTER DISASSEMBLY

Inspect the following items.

Cylinder Body

- Check the inner wall of the cylinder for damage, wear, corrosion, and pin holes. Replace cylinder body if a malfunction is detected.

ASSEMBLY

CAUTION:

- Never use mineral oils such as kerosene or gasoline during the cleaning and assembly processes.
- Make sure that there is no foreign material such as dirt and dust on the inner wall of the cylinder, piston, and cup seal. Be careful not to damage the parts with a service tool when assembling.

BRAKE MASTER CYLINDER

- Do not drop the parts. Do not use any dropped parts.

Models without ICC

1. Apply brake fluid to the inner wall of cylinder body and contact surface of the piston assembly.
2. Insert secondary piston and primary piston assembly into cylinder body in this order.

CAUTION:

- Do not reuse primary and secondary piston assemblies.
- Pay attention to the orientation of the piston cup, and insert straight to prevent the cup from being caught by the inner wall of the cylinder.
- Always replace the inner kit as an assembly.

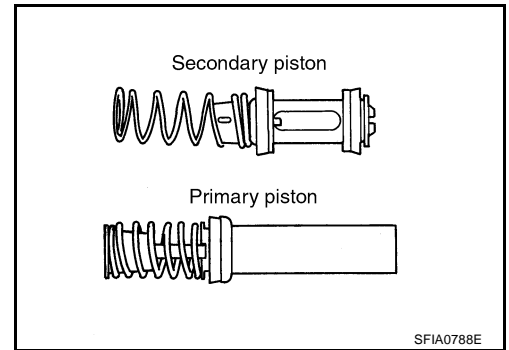

3. Install the piston stopper through a slit of secondary piston, while setting the slit of the piston towards a hole of cylinder body.

CAUTION:

Always replace the piston pin O-ring with new one in the repair kit.

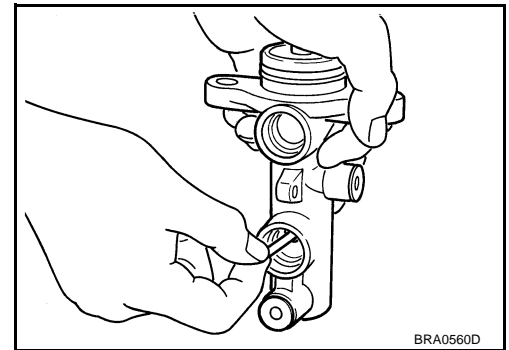

4. Insert plate and guide assembly into cylinder body.

CAUTION:

- Be careful not to damage the rod of the primary piston.
- Pay attention to the orientation of guide assembly.
- Do not drop the O-ring.
- Be careful guide assembly and plate are inserted at a right angle.
- Do not reuse plate and guide assembly.

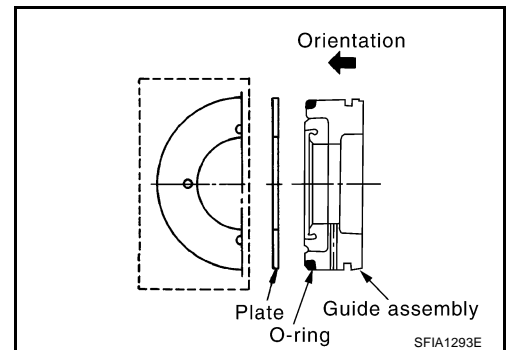

5. Be careful not to damage the rod of the primary piston with covering cloths. Then insert snap ring to cylinder with pushing primary piston.

CAUTION:

- Make sure that snap ring is securely engaged at a groove in the cylinder body inner diameter.
- Do not reuse the snap ring.

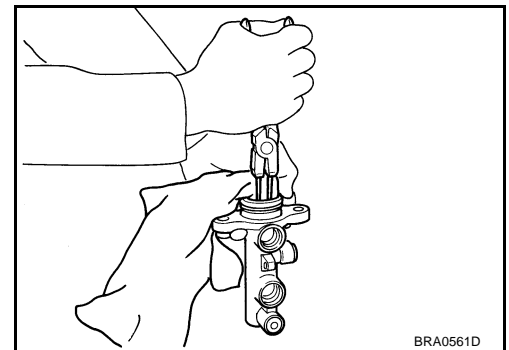

6. Apply brake fluid to grommet, and press it into cylinder body to install.

CAUTION:

Do not reuse grommet.

A
B
C
D
E
BR
G
H
I
J
K
L
M

BRAKE MASTER CYLINDER

7. Install reservoir tank to cylinder body.

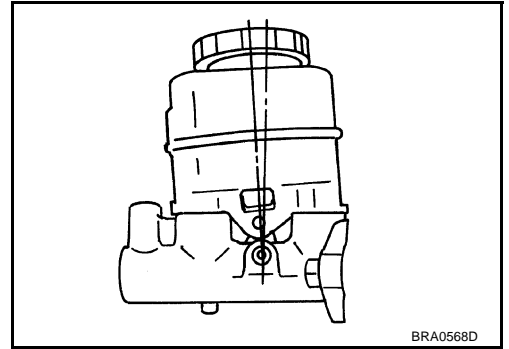

8. Clamp the flange of cylinder body in the figure.

CAUTION:

- Use copper plates or cloths to protect the flange when securing in a vise.
- Pay attention to the orientation of the cylinder body.

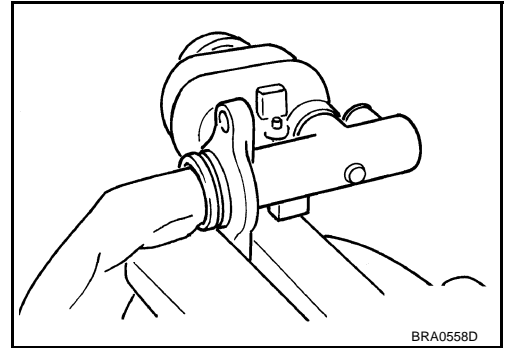

9. Using a pin punch [commercial service tool: approx. 4mm (0.16 in) dia.], attach the reservoir tank mounting pin so that the attachment side and the opposite are identical.

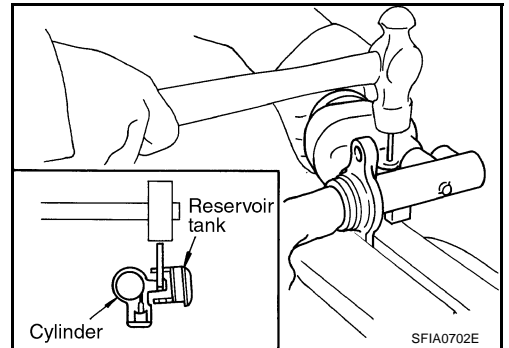

BRAKE MASTER CYLINDER

Models with ICC

1. Apply brake fluid to the inner wall of cylinder body and contact surface of the piston assembly.
2. Insert secondary piston and primary piston assembly into cylinder body in this order.

CAUTION:

- Do not reuse primary and secondary piston assemblies.
- Pay attention to the orientation of the piston cup, and insert straight to prevent the cup from being caught by the inner wall of the cylinder.
- Always replace the inner kit as an assembly.

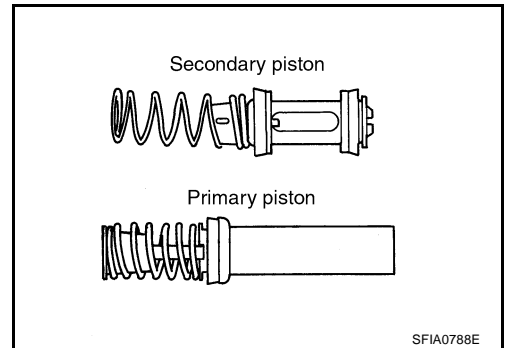

3. Insert plate and guide assembly into the cylinder body.

CAUTION:

- Be careful not to damage the rod of the primary piston.
- Pay attention to the orientation of guide assembly.
- Do not drop the O-ring.
- Be careful guide assembly and plate are inserted at a right angle.
- Do not reuse plate and guide assembly.

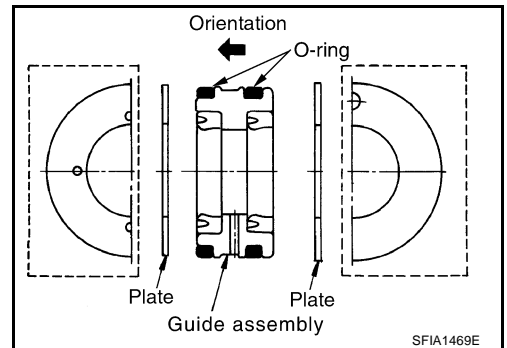

4. Be careful not to damage the rod of the primary piston with covering cloths. Then insert snap ring to cylinder with pushing primary piston.

CAUTION:

- Make sure that snap ring is securely engaged at a groove in the cylinder body inner diameter.
- Do not reuse the snap ring.

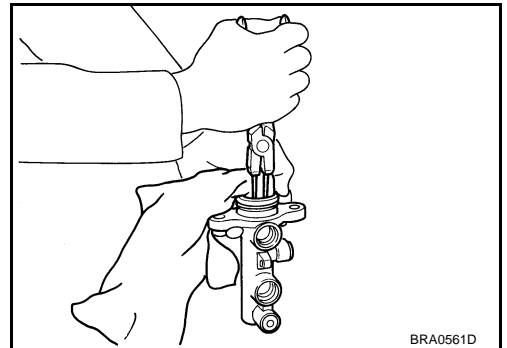

5. Install the piston stopper through a slit of secondary piston, while setting the slit of the piston to wards a piston stopper hole of cylinder body.

CAUTION:

Always replace piston pin, O-ring with new one in the repair kit.

6. Apply brake fluid to grommet, and press it into master cylinder to install.

CAUTION:

Do not reuse grommet.

7. Press a reservoir tank in the cylinder body.

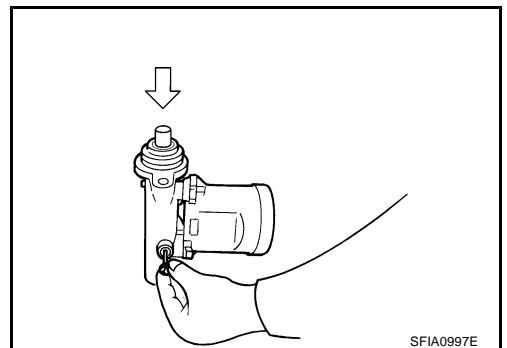

A
B
C
D
E
BR
G
H
I
J
K
L
M

BRAKE BOOSTER

BRAKE BOOSTER

PFP:47200

On-Vehicle Inspection OPERATING CHECK

NFS000BK

With engine stopped, change a vacuum to atmospheric pressure by depressing brake pedal several times. Then with brake pedal fully depressed, start engine and when a vacuum reaches the standard, make sure that clearance between brake pedal and floor panel decreases.

CAUTION:

Depressing pedal interval is approximately 5 seconds.

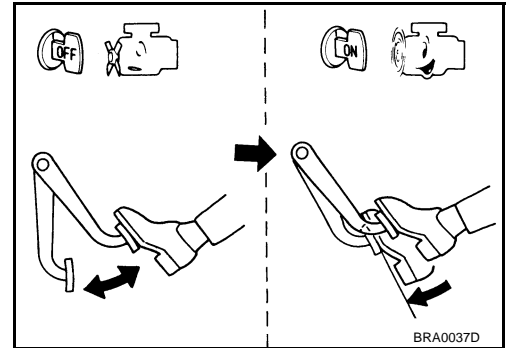

AIRTIGHT CHECK

- Run engine at idle for approximately 1 minute, and stop it after applying vacuum to booster. Depress brake pedal normally to change vacuum to atmospheric pressure. Make sure that distance between brake pedal and floor panel gradually increases.

CAUTION:

Depressing brake pedal is approximately at intervals of 5 seconds.

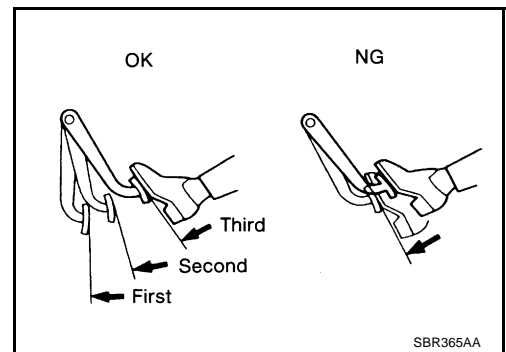

Components

NFS00010

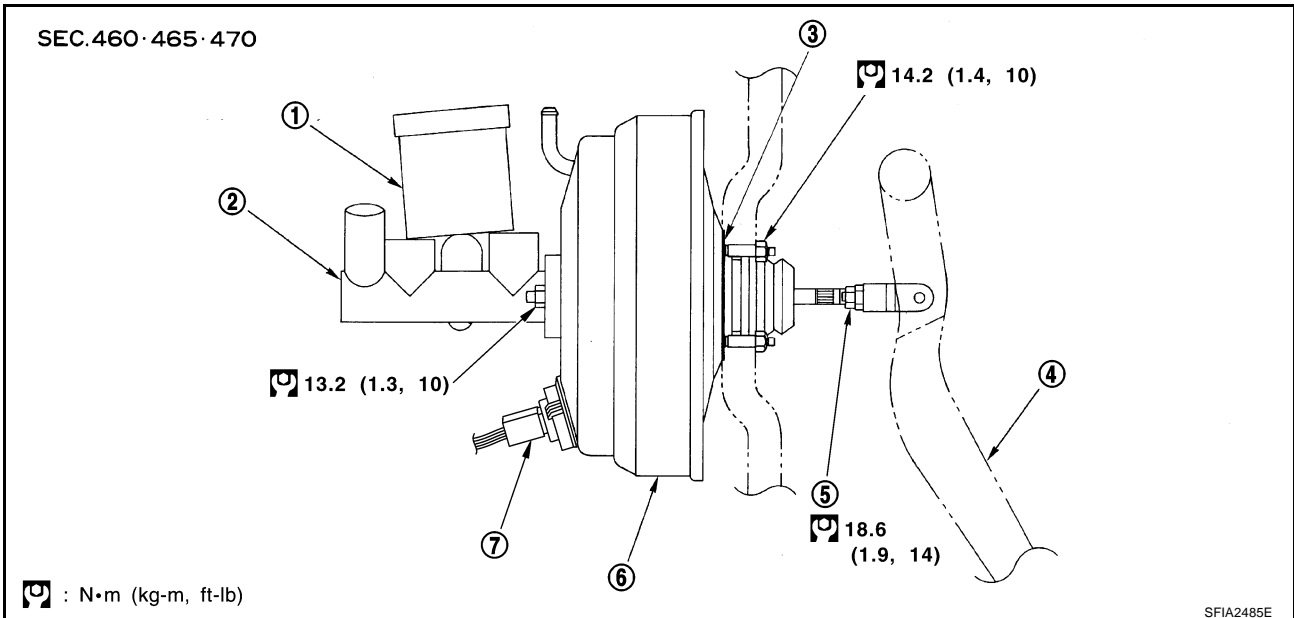

- | | | |
|---|--------------------|------------------|
| 1. Reservoir tank | 2. Master cylinder | 3. Gasket |
| 4. Brake pedal | 5. Lock nut | 6. Brake booster |
| 7. Solenoid harness connector
(only ICC model) | | |

BRAKE BOOSTER

NFS000BL

Removal and Installation

REMOVAL

CAUTION:

- Be careful not to splash brake fluid on painted areas; it may cause paint damage. If brake fluid is splashed on painted areas, wash it away with water immediately.
 - Be careful not to deform or bend brake pipes, during removal of booster.
1. Remove vacuum hose from brake booster.
 2. Remove master cylinder. Refer to [BR-13, "REMOVAL"](#).
 3. Disconnect solenoid harness connector from brake booster assembly (only ICC model).
 4. Remove snap pin and clevis pin on the clevis in the passenger room, and remove input rod from brake pedal.
 5. Remove the mounting nuts on pedal bracket.
 6. Remove booster assembly from the engine room.

INSPECTION AFTER REMOVAL

Output Rod Length Inspection

1. Using a handy vacuum pump, apply a vacuum of -66.7 kPa (-500 mmHg , 19.69 inHg) to brake booster.
2. Check output rod length.

Standard dimension when vacuum

-66.7 kPa (-500 mmHg , -19.69 inHg)

Without ICC: : -6.2 mm (-0.24 in)

With ICC: : 10.4 mm (0.409 in)

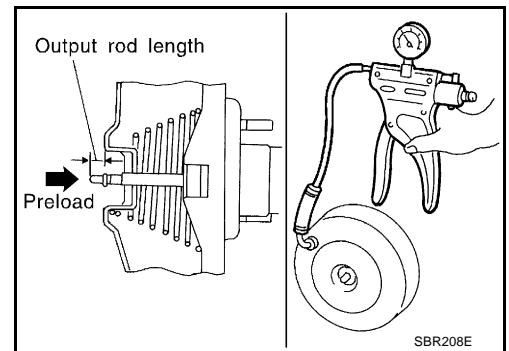

INSTALLATION

1. Loosen the lock nut to adjust input rod length so that the length "B" (in the figure on the left) satisfies the specified value.

Length "B" : 125 mm (4.92 in)

2. After adjusting "B", temporarily tighten the lock nut to install the booster assembly to vehicle. At this time, make sure to install a gasket between booster assembly and vehicle.
3. Connect the brake pedal with clevis of input rod.
4. Install the pedal bracket mounting nuts and tighten them to the specified torque. Refer to [BR-7, "Components"](#).
5. Install master cylinder to booster assembly. Refer to [BR-13, "INSTALLATION"](#).
6. Connect solenoid harness connector to brake booster assembly (only ICC model).
7. Adjust the height and play of brake pedal. Refer to [BR-6, "Inspection and Adjustment"](#).
8. Tighten the lock nut of input rod to the specified torque. Refer to [BR-20, "Components"](#).
9. Bleed air. Refer to [BR-9, "Bleeding Brake System"](#).

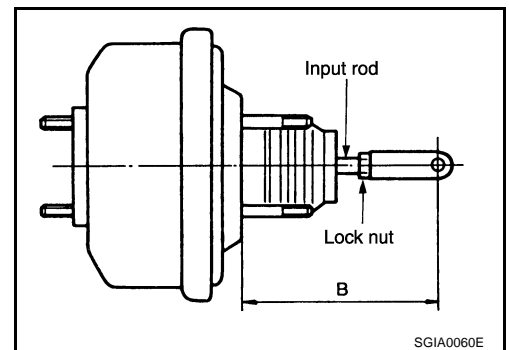

VACUUM LINES

VACUUM LINES

PFP:41920

Components

NFS000BM

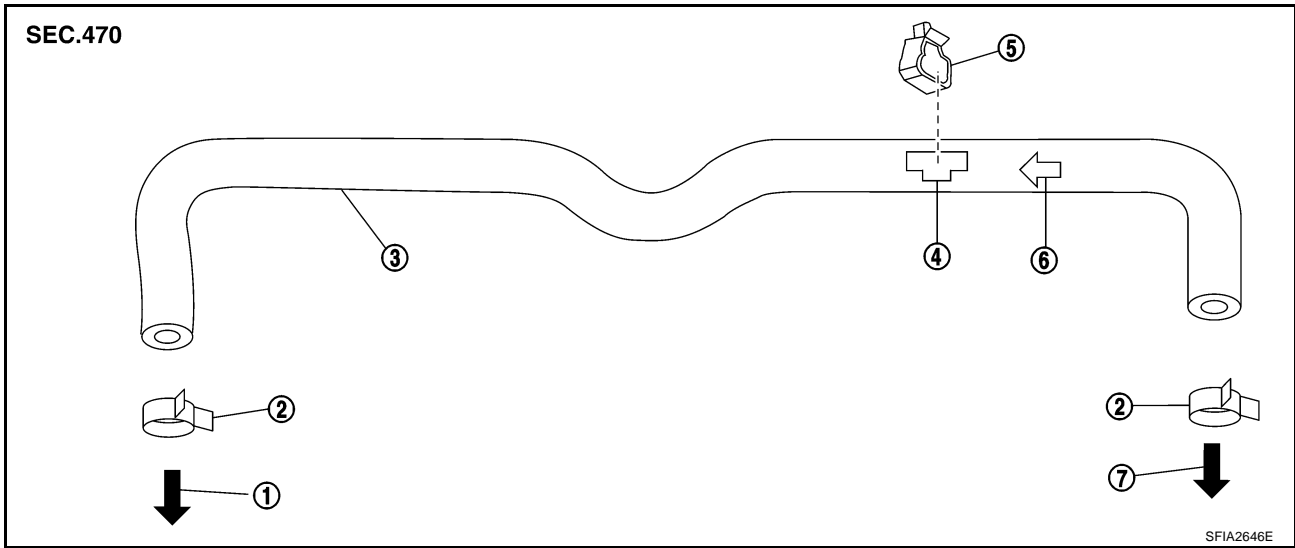

- | | | |
|------------------------|----------|---------------------------------------|
| 1. For intake manifold | 2. Clamp | 3. Vacuum hose (Build-in check valve) |
| 4. Clip position stamp | 5. Clip | 6. Engine side indicator stamp |
| 7. For brake booster | | |

Removal and Installation

NFS000BN

CAUTION:

- Because vacuum hose contains a check valve, it must be installed in the correct direction. Refer to the stamp or label to confirm correct installation. The brake booster will not operate normally if hose is installed in the wrong direction.
- Position clip with clip position stamp when installing clip to vacuum hose.
- Insert vacuum hose for at least 24 mm (0.94 in).
- Do not use lubricating oil during assembly.

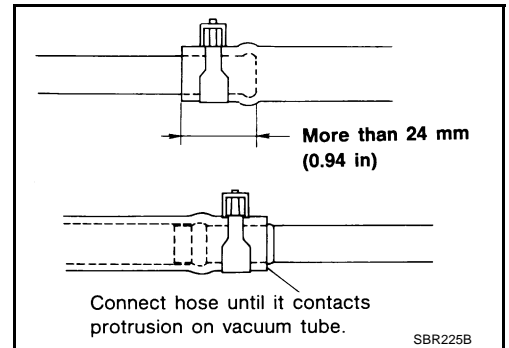

Inspection

VISUAL INSPECTION

Check for improper assembly, damage and deterioration.

CHECK VALVE INSPECTION

Airtightness Inspection

Use a handy vacuum pump to check.

When connected to booster side (1):

Vacuum decrease should be within 1.3 kPa (10 mmHg, 0.39 inHg) for 15 seconds under a vacuum of -66.7 kPa (-500 mmHg, -19.69 inHg)

When connected to engine side (2):

No vacuum will be applied

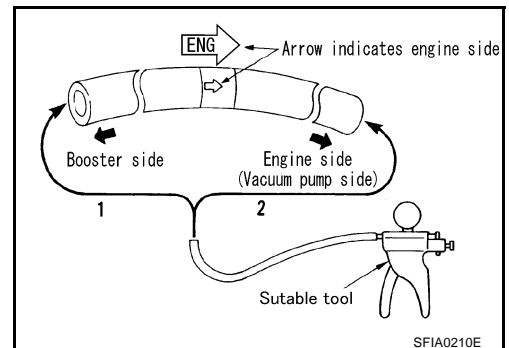

FRONT DISC BRAKE

FRONT DISC BRAKE

PFP:41000

On-Vehicle Inspection PAD WEAR INSPECTION

NFS000BP

- Check pad thickness from check hole on cylinder body.

Standard thickness : 10.0 mm (0.394 in)
Repair limit thickness : 2.0 mm (0.079 in)

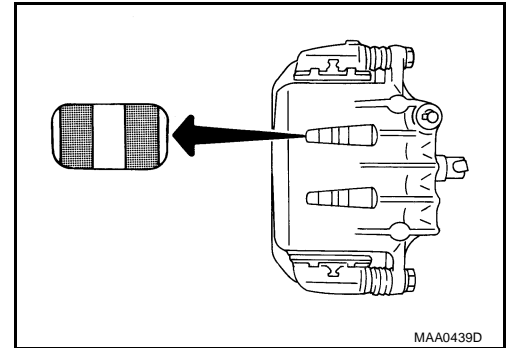

MAA0439D

Components

NFS000BQ

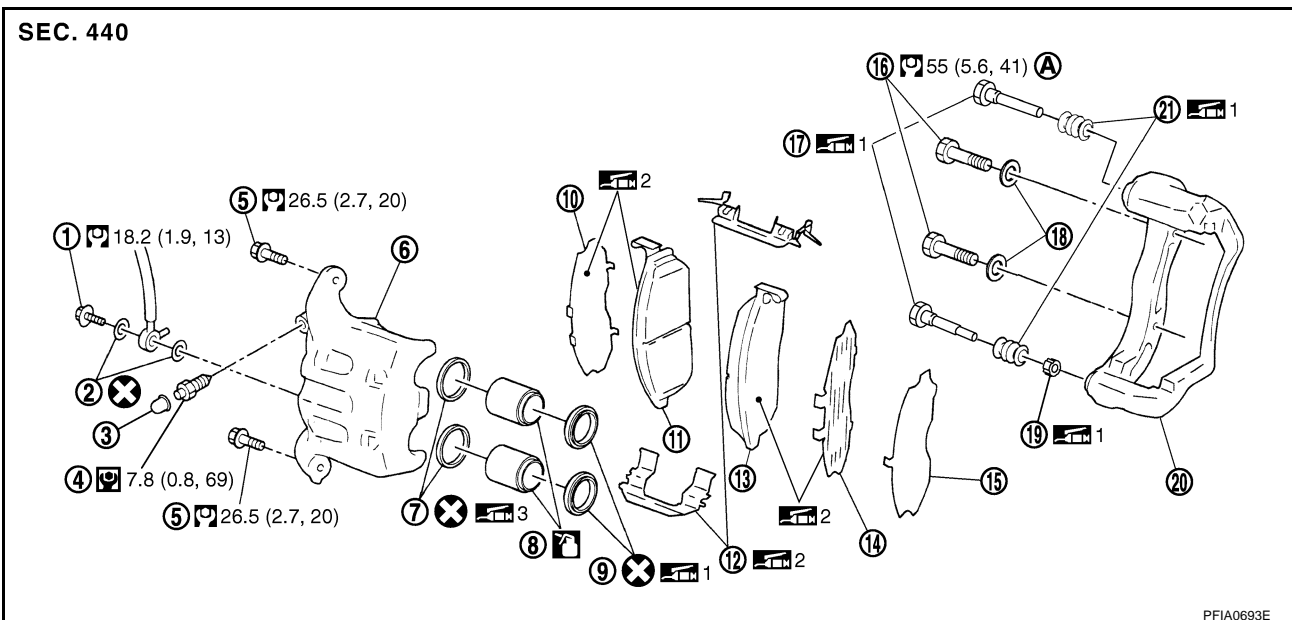

PFA0693E

- | | | |
|---------------------------------|---------------------|----------------------|
| 1. Union bolt | 2. Copper washer | 3. Cap |
| 4. Bleed valve | 5. Sliding pin bolt | 6. Cylinder body |
| 7. Piston seal | 8. Piston | 9. Piston boot |
| 10. Inner shim | 11. Inner pad | 12. Pad retainer |
| 13. Outer pad | 14. Outer shim | 15. Outer shim cover |
| 16. Torque member mounting bolt | 17. Sliding pin | 18. Washer |
| 19. Bushing | 20. Torque member | 21. Sliding pin boot |

A: After tightening the bolts to the specified torque, tighten the bolts additionally by turning the bolts 32 to 37 degrees.

Refer to [GI-9. "Components"](#) and the followings for the symbols in the figure.

1: Apply rubber grease.

2: Apply PBC (Poly Butyl Cuprysil) grease or silicone-based grease.

3: Apply polyglycol ether based lubricant.

: Apply brake fluid.

WARNING:

Clean dust on caliper and brake pad with a vacuum dust collector to minimize the hazard of airborne particles or other materials. Do not blow with compressed air.

CAUTION:

- While removing cylinder body, do not depress brake pedal because piston will pop out.

FRONT DISC BRAKE

- It is not necessary to remove torque member mounting bolts on torque member and brake hose except for disassembly or replacement of caliper assembly. In this case, hang cylinder body with a wire so that brake hose is not under tension.
- Do not damage piston boot.
- Always replace shim and shim covers as a set when replacing brake pads.
- Keep rotor clean off brake fluid.

Removal and Installation of Brake Pad

NFS000BR

REMOVAL

WARNING:

Clean brake pads with a vacuum dust controller to minimize a hazard of airborne particles or other materials.

CAUTION:

- When cylinder body is opened, do not depress brake pedal because piston will pop out.
 - Be careful not to damage piston boot or get oil on disc rotor. Always replace shims in replacing pads.
 - If shims are rusted or show peeling of rubber coat, replace them with new shims.
 - It is not necessary to remove torque member mounting bolt except for disassembly or replacement of caliper assembly. In this case, suspend cylinder body with wire so as not to stretch brake hose.
 - Carefully monitor brake fluid level because brake fluid will return to reservoir when pushing back piston.
 - Burnish brake contact surfaces after refinishing or replacing drums or rotors, after replacing pads or linings, or if a soft pedal occurs at very low mileage. Refer to [BR-28, "Brake Burnishing Procedure"](#).
1. Remove tires from vehicle with a power tool.
 2. Remove lower sliding pin bolt.

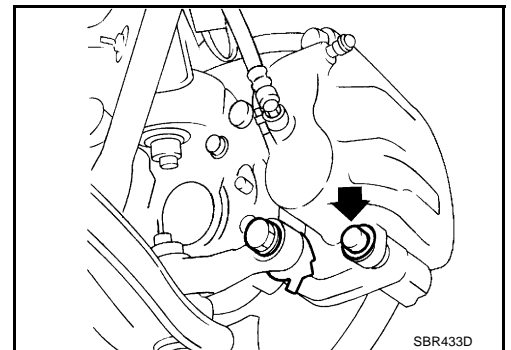

3. Hang cylinder body with a wire, and remove pads, pad retainers, shims from torque member.

CAUTION:

- Do not damage piston boot.
- Keep rotor clean, off brake fluid.
- When removing pad retainer from torque member, lift pad retainer in the direction shown by arrow (shown in the figure) so as not to deform it.
- Do not damage piston boot.
- Keep rotor clean, off brake fluid.

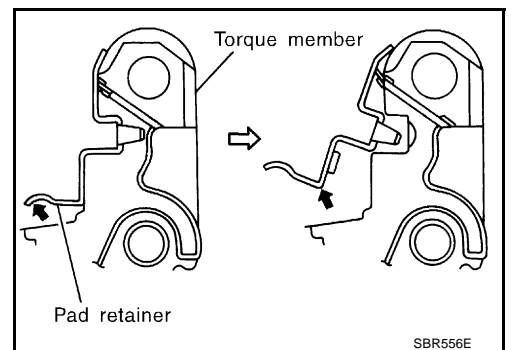

FRONT DISC BRAKE

INSTALLATION

1. Apply PBC (Poly Butyl Cuprysil) or equivalent to the both sides of inner shim and outer shim, install inner shim to inner pad, and outer shim and outer shim cover to outer pad.
2. Apply PBC (Poly Butyl Cuprysil) or equivalent to pad contact surface on pad retainer, and install pad retainers and pads to torque member.

CAUTION:

Inner pad and outer pad have pad-return mechanism on upper side of pad retainer. When installing pad to torque member, be sure to install pad return lever to pad wear sensor securely.

3. Install cylinder body to torque member.

CAUTION:

When replacing pads with new ones, press in piston until pads can be installed. In this case, carefully monitor brake fluid level in reservoir tank because brake fluid will return to master cylinder reservoir tank.

4. Install lower sliding pin bolt, and tighten it to the specified torque. Refer to [BR-23, "Components"](#) .
5. Secure disc rotor with wheel nuts. Depress brake pedal a few times until it gets a responsive touch.
6. Check brake for drag.
7. Install tires to vehicle.

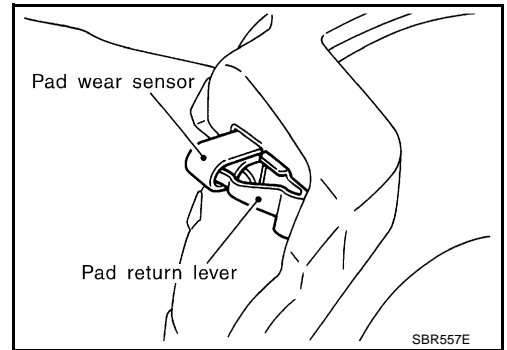

Removal and Installation of Brake Caliper Assembly

NFS000BS

REMOVAL

1. Remove tires from vehicle with a power tool.
2. Drain brake fluid gradually from bleed valve while depressing brake pedal. Refer to [BR-9, "Drain and Refill"](#) .
3. Remove union bolts, and then remove brake hose from caliper assembly.
4. Remove torque member mounting bolts from torque member, and remove caliper assembly from vehicle with a power tool.
5. Remove disc rotor.

CAUTION:

Put matching mark on both disc rotor and wheel hub when removing disc rotor.

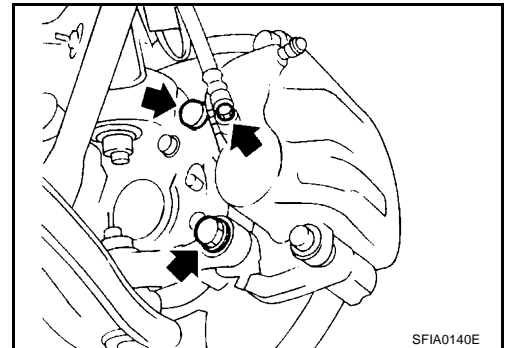

INSTALLATION

1. Install disc rotor.
CAUTION:
Align the marks of disc rotor and wheel hub, which were marked at the time of removal when reusing disc rotor.
2. Install caliper assembly to vehicle, and tighten mounting bolts to the specified torque. Refer to [BR-23, "Components"](#) .
CAUTION:
Before installing torque member to vehicle, wipe oil and grease on washer seats on steering knuckle and mounting surface of torque member.
3. Install a projection of brake hose metal fitting by aligning with protrusions on cylinder body, and tighten union bolts to the specified torque. Refer to [BR-23, "Components"](#) .
CAUTION:
 - Do not reuse copper washer for union bolts.
 - Assemble brake hose securely on caliper assembly.
4. After installing caliper assembly, refill with new brake fluid and bleed air. Refer to [BR-9, "BRAKE FLUID"](#) .
5. Install tires to vehicle.

FRONT DISC BRAKE

Disassembly and Assembly of Brake Caliper Assembly

NFS000BT

NOTE:

Do not remove torque member, brake pads, shims, shim cover and pad retainer, when disassembling or assembling cylinder body.

DISASSEMBLY

1. Remove caliper assembly from vehicle. Refer to [BR-25](#), "[Removal and Installation of Brake Caliper Assembly](#)".
2. Remove sliding pin bolts from cylinder body, and remove pad, shim, shim cover and pad retainer from torque member.

CAUTION:

When removing pad retainer from torque member, lift the pad retainer in the direction shown by arrow (shown in the figure) so as not to deform it.

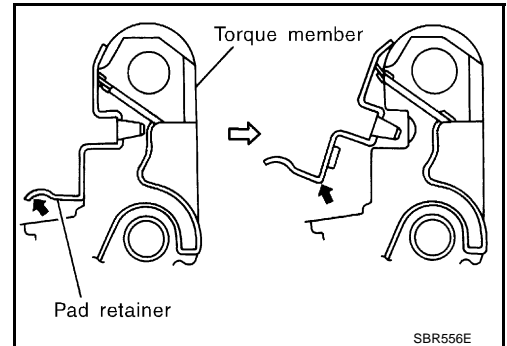

3. Remove sliding pins and sliding pin boots from torque member.
4. Place a wooden block as shown in the figure, and blow air from union bolt mounting hole to remove pistons and piston boots.

CAUTION:

Do not get your fingers caught in piston.

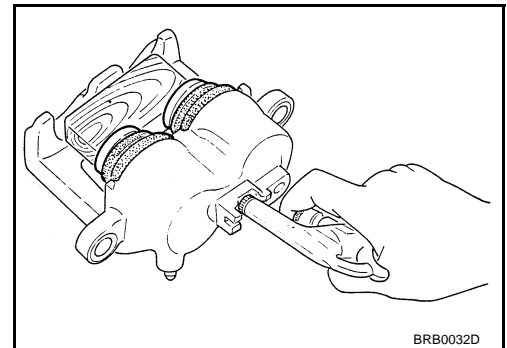

5. Using a flat-bladed screwdriver, remove piston seals from cylinder body.

CAUTION:

Be careful not to damage the inner wall of cylinder.

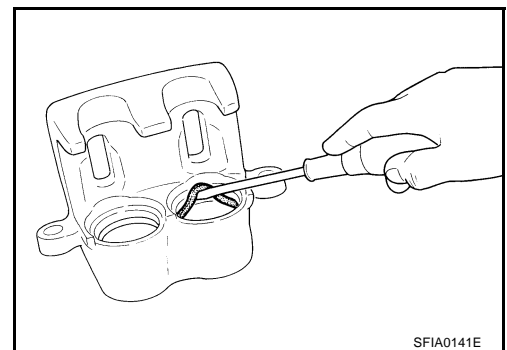

INSPECTION AFTER DISASSEMBLY

Cylinder Body

CAUTION:

Use new brake fluid to clean. Do not use mineral oils such as gasoline or kerosene.

- Check the inner wall of cylinder for corrosion, wear, and damage. If a malfunction is detected, replace cylinder body.
- Minor flaws caused by corrosion or a foreign material can be removed by polishing a surface of the inner wall with a fine sandpaper. Replace cylinder body, if necessary.

Torque Member

Check for wear, cracks, and damage. If a malfunction is detected, replace applicable part.

Piston

CAUTION:

The piston sliding surface is plated. Do not polish with sandpaper.

Check piston surface for corrosion, wear, and damage. If a malfunction is detected, replace applicable part.

FRONT DISC BRAKE

Sliding Pin, Sliding Pin Bolt, and Sliding Pin Boot

Check sliding pins and sliding pin boots for wear, damage, and cracks. If a malfunction is detected, replace applicable part.

ASSEMBLY

1. Apply polyglycol ether based lubricant to piston seal, and install them to the cylinder body.

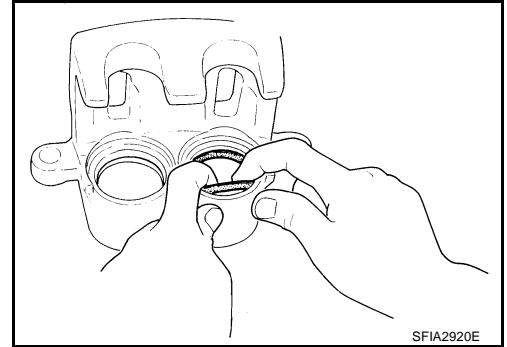

2. Apply rubber grease to piston boots. Cover the piston end with piston boot, and install cylinder-side lip on piston boot properly into groove on cylinder body.

CAUTION:

Do not reuse piston boot.

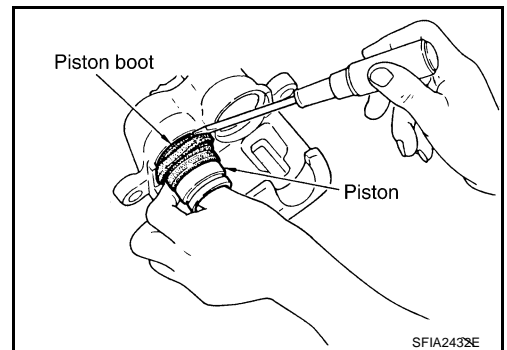

3. Apply brake fluid to piston, and press piston into cylinder body by hand to assemble piston-side lip on piston boot properly into a groove on piston.

CAUTION:

Press piston evenly and change pressing point to prevent inner wall of cylinder from being rubbed.

4. Install sliding pins and sliding pin boots to the torque member.

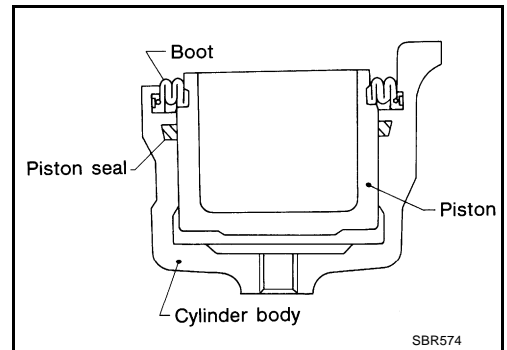

5. Install the torque member to the knuckle spindle and tighten the mounting bolts to the specified torque. Refer to [BR-23, "Components"](#).

CAUTION:

Before installing torque member to vehicle, wipe oil and grease on the washer seats on steering knuckle and the mounting surface of the torque member.

6. Install pad retainers to torque member.
7. After assembling shims and shim covers to pad, install it to torque member.

CAUTION:

Inner pad and outer pad have pad-return mechanism on the upper side of the pad retainer. When installing pad, be sure to install pad return lever to pad wear sensor securely as shown in the figure.

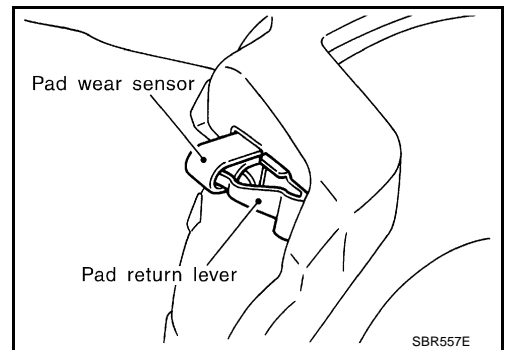

8. Install cylinder body, and tighten sliding pin bolt to specified torque. Refer to [BR-23, "Components"](#).
9. Install a projection of brake hose metal fitting by aligning with protrusions on cylinder body and tighten union bolts to specified torque. Refer to [BR-10, "Hydraulic Circuit"](#).

FRONT DISC BRAKE

CAUTION:

- Assemble brake hose securely to protrusions on cylinder body.
- Do not reuse copper washer for union bolts.

10. After installing caliper assembly, refill with new brake fluid and bleed air. Refer to [BR-9, "BRAKE FLUID"](#) .

DISC ROTOR INSPECTION

Visual Inspection

Check surfaces of disc rotor for uneven wear, cracks, and serious damage. If a malfunction is detected, replace applicable part.

Run Out Inspection

1. Using wheel nuts, fix disc rotor to wheels hub. (2 or more positions)
2. Using a dial indicator, check run out.

Measurement point : At a point 10.0 mm (0.394 in) from outer edge of disc.

Run out limit : 0.07 mm (0.0028 in) or less

CAUTION:

Before measuring, make sure that axle end play is 0 mm.

3. If run out is outside limit, find the minimum run out point by shifting the mounting positions of disc rotor and wheel hub by one hole.

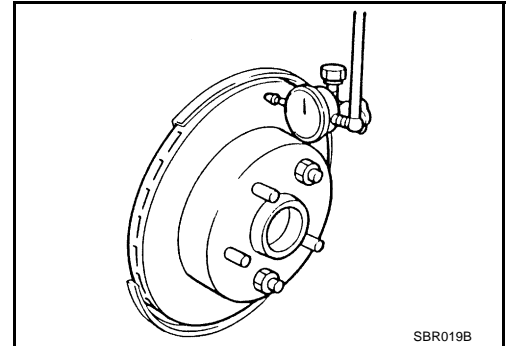

Thickness Inspection

1. Using a micrometer, check thickness of disc rotor. If thickness is outside standard, replace disc rotor.

Standard thickness : 28.0 mm (1.102 in)

Wear limit : 26.0 mm (1.024 in)

Maximum uneven wear (measured at 8 positions) : 0.015 mm (0.0006 in) or less

2. If run out is still out of specification, turn rotor with on-car brake lathe ("MAD, DL-8700", "AMMCO 700 and 705" or equivalent).

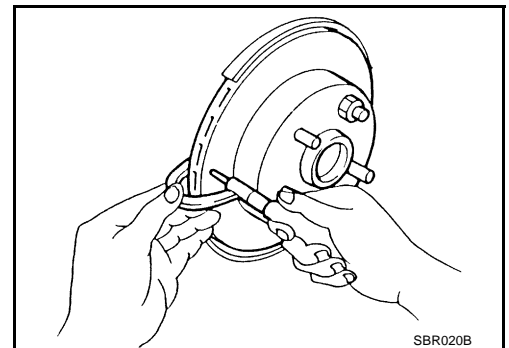

Brake Burnishing Procedure

NFS000BU

Burnish brake pad (or lining) contact surfaces of disc rotor according to following procedure after refinishing or replacing drums or rotors, after replacing pads or linings, or if a soft pedal occurs at very low mileage.

CAUTION:

- Be careful of vehicle speed because brake does not operate easily until pad and disc rotor are securely fitted.
 - Only perform this procedure under safe road and traffic conditions. Use extreme caution.
1. Drive vehicle on straight, flat road.
 2. Depress brake pedal with the power to stop vehicle within 3 to 5 seconds until the vehicle stops.
 3. Drive without depressing brake for a few minutes to cool brake.
 4. Repeat steps 1 to 3 until pad and disc rotor are securely fitted.

REAR DISC BRAKE

REAR DISC BRAKE

PFP:44000

On-Vehicle Inspection PAD WEAR INSPECTION

NFS000BV

- Check pad thickness from check hole on cylinder body.

Standard thickness : 9.8 mm (0.386 in)
Replace limit thickness : 2.0 mm (0.079 in)

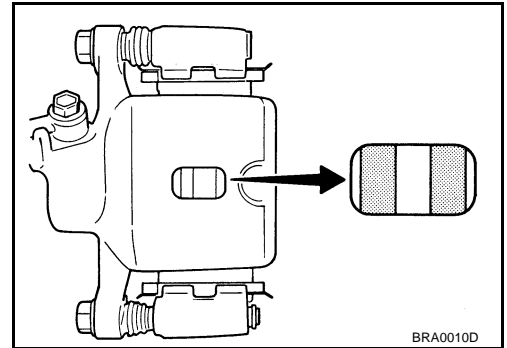

BRA0010D

Components

NFS000BW

SEC. 441

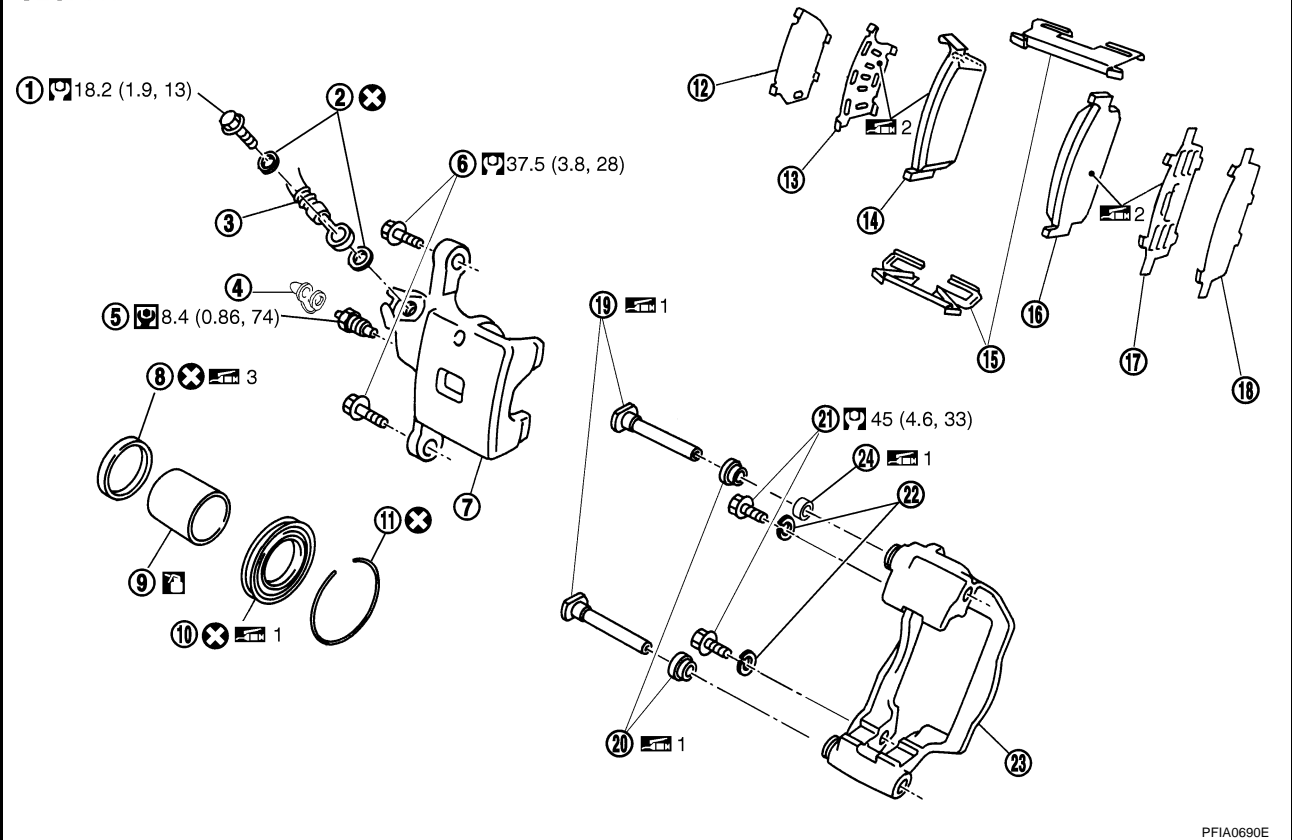

PFA0690E

- | | | |
|------------------|----------------------|---------------------------------|
| 1. Union bolt | 2. Copper washer | 3. Brake hose |
| 4. Cap | 5. Bleed valve | 6. Sliding pin bolt |
| 7. Cylinder body | 8. Piston seal | 9. Piston |
| 10. Piston boot | 11. Retaining ring | 12. Inner shim cover |
| 13. Inner shim | 14. Inner pad | 15. Pad retainer |
| 16. Outer pad | 17. Outer shim | 18. Outer shim cover |
| 19. Sliding pin | 20. Sliding pin boot | 21. Torque member mounting bolt |
| 22. Washer | 23. Torque member | 24. Bushing |

Refer to [GI-9, "Components"](#) and the followings for the symbols in the figure.

1: Apply rubber grease.

2: Apply PBC (Poly Butyl Cuprysil) grease or silicone-based grease.

REAR DISC BRAKE

 3: Apply polyglycol ether based lubricant.

 : Apply brake fluid.

WARNING:

Clean dust on caliper and brake pad with vacuum dust collector to minimize the hazard of airborne particles or other materials. Do not blow with compressed air.

CAUTION:

- While removing cylinder body, do not depress brake pedal because piston will pop out.
- It is not necessary to remove torque member mounting bolts on torque member and brake hose except for disassembly or replacement of caliper assembly. In this case, hang cylinder body with a wire so that brake hose is not under tension.
- Do not damage piston boot.
- Always replace shims and shim covers as a set when replacing brake pads.
- Keep rotor clean, off brake fluid.

Removal and Installation of Brake Pad

NFS000BX

REMOVAL

WARNING:

Clean brake pads with vacuum dust collector to minimize the hazard of airborne particles or other materials.

CAUTION:

- While cylinder body is open, do not depress brake pedal, otherwise piston will pop out.
 - Be careful not to damage piston boot or get oil on rotor. Always replace shims when replacing pads.
 - If shims are rusted or show peeling of rubber coat, replace them with new shims.
 - It is not necessary to remove torque member mounting bolt except for disassembly or replacement of caliper assembly. In this case, suspend cylinder body with a wire so as not to stretch brake hose.
 - Carefully monitor brake fluid level because brake fluid will return to reservoir tank when pushing back piston.
 - Burnish the rotor surfaces contacting with pads or linings after refinishing or replacing drums or rotors, after replacing pads or linings, or if a soft pedal occurs at very low mileage. Refer to [BR-34, "Brake Burnishing Procedure"](#).
1. Remove tires from vehicle with a power tool.
 2. Remove lower sliding pin bolt.
 3. Hang cylinder body with a wire, and remove pads, pad retainers, shims from torque member.

CAUTION:

- Do not damage piston boot.
- Keep rotor clean, off brake fluid.

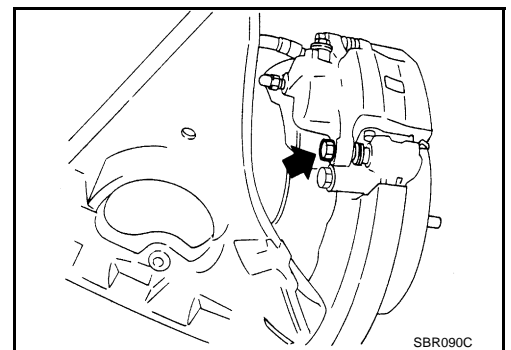

INSTALLATION

1. Apply PBC (Poly Butyl Cuprysil) or equivalent to both sides of inner shim and outer shim, and install inner shim and shim cover to inner pad, and outer shim and outer shim cover to pad.
2. Install cylinder body to torque member.

CAUTION:

When replacing pads with new ones, press in piston until pads can be installed. In this case, carefully monitor brake fluid level in reservoir tank because brake fluid will return to master cylinder reservoir tank.

3. Insert lower sliding pin bolt to tighten to the specified torque. Refer to [BR-29, "Components"](#).
4. Fix disc rotor with a wheel nut. Depress brake pedal a few times until it gets a responsive touch.

REAR DISC BRAKE

5. Check brake for drag.
6. Install tires to vehicle.

Removal and Installation of Brake Caliper Assembly

NFS000BY

REMOVAL

1. Remove tires from vehicle with a power tool.
2. Drain brake fluid gradually from bleed valve while depressing brake pedal. Refer to [BR-9, "Drain and Refill"](#).
3. Remove union bolts, and then remove brake hose from caliper assembly.
4. Remove torque member mounting bolts from torque member, and remove caliper assembly from vehicle with a power tool.
5. Remove disc rotor.

CAUTION:

Put matching mark on both disc rotor and wheel hub when removing disc rotor.

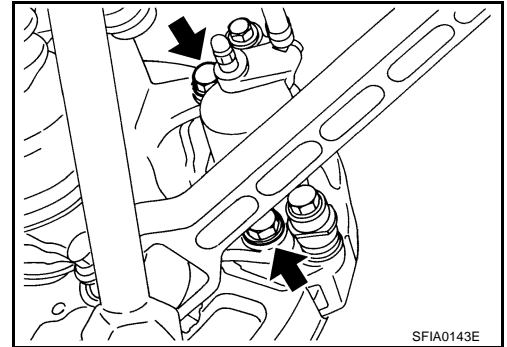

INSTALLATION

1. Install disc rotor.

CAUTION:

Align the marks of disc rotor and wheel hub, which were marked at the time of removal when reusing disc rotor.

2. Install caliper assembly to vehicle, and tighten torque member mounting bolts to specified torque. Refer to [BR-29, "Components"](#).

CAUTION:

Before installing caliper assembly to vehicle, wipe oil and grease on washer seats on axle assembly and mounting surface of caliper assembly.

3. Install brake hose to caliper assembly and tighten union bolts to the specified torque. Refer to [BR-10, "Hydraulic Circuit"](#).

CAUTION:

- Do not reuse copper washer for union bolts.
- Install a projection of brake hose metal fitting by aligning with protrusions on cylinder body.

4. After installing caliper assembly, refill with new brake fluid and bleed air. Refer to [BR-9, "BRAKE FLUID"](#).
5. Install tires to vehicle.

Disassembly and Assembly of Brake Caliper Assembly

NFS000BZ

DISASSEMBLY

1. Remove caliper assembly from vehicle. Refer to [BR-31, "Removal and Installation of Brake Caliper Assembly"](#).
2. Remove sliding pins. Then remove pads, shims, and shim covers from caliper assembly, and remove pad retainers from cylinder body.
3. Remove sliding pin boot from torque member.
4. Using a flat-bladed screwdriver as shown in figure, remove retaining ring from cylinder body.

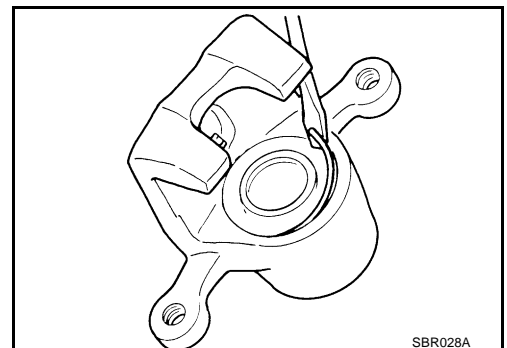

REAR DISC BRAKE

5. Place a wooden block as shown in figure, and blow air from union bolt mounting hole to remove pistons and piston boots.

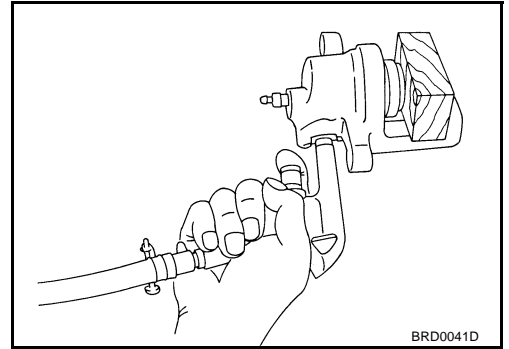

6. Using a flat-bladed screwdriver, remove piston seals from cylinder body.

CAUTION:

Be careful not to damage the inner wall of cylinder.

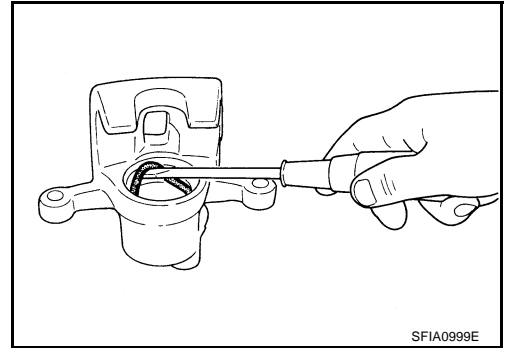

INSPECTION AFTER DISASSEMBLY

Cylinder Body

CAUTION:

Use new brake fluid to clean. Do not use mineral oils such as gasoline or kerosene.

- Check the inner wall of cylinder for corrosion, wear, and damage. If a malfunction is detected, replace cylinder body.
- Minor flaws caused by corrosion or foreign material can be removed by polishing a surface of the inner wall with a fine sandpaper. Replace cylinder body, if necessary.

Torque Member

Check for wear, cracks, and damage. If a malfunction is detected, replace applicable part.

Piston

CAUTION:

The piston sliding surface is plated. Do not polish with sandpaper.

Check piston surface for corrosion, wear, and damage. If a malfunction is detected, replace applicable part.

Sliding Pin, Sliding Pin Bolt and Sliding Pin Boot

Check sliding pins and sliding pin boots for wear, damage, and cracks. If a malfunction is detected, replace applicable part.

ASSEMBLY

CAUTION:

When assembling, use only rubber lubricant specified below.

1. Apply polyglycol ether based lubricant to piston seal, and install them to the cylinder body.

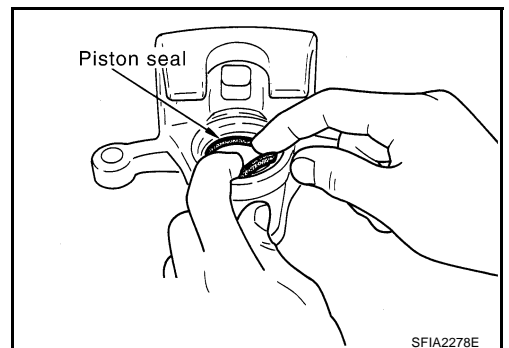

REAR DISC BRAKE

2. Apply rubber grease to piston boots. Cover the piston end with piston boot, and install cylinder side lip on piston boots properly into groove on cylinder body.

CAUTION:

Do not reuse piston boot.

3. Apply brake fluid to piston, and press piston into cylinder body by hand to assemble piston side lip on piston boot properly into groove on piston.

CAUTION:

Press piston evenly and change the pressing point to prevent the inner wall of cylinder from being rubbed.

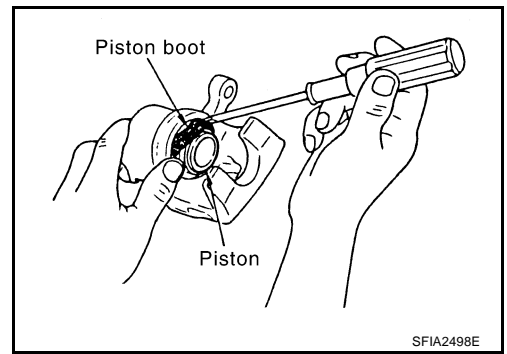

4. Fix the piston boot with retaining ring.

CAUTION:

- **Make sure that boot is securely engaged in a groove on cylinder body.**

- **Do not reuse retaining ring.**

5. Install sliding pins and sliding pin boots to torque member.
6. Install torque member to axle assembly, and tighten torque member mounting bolts to the specified torque. Refer to [BR-29, "Components"](#).

CAUTION:

Before installing torque member to axle assembly, wipe oil and grease on washer seats on axle assembly and mounting surfaces of torque member.

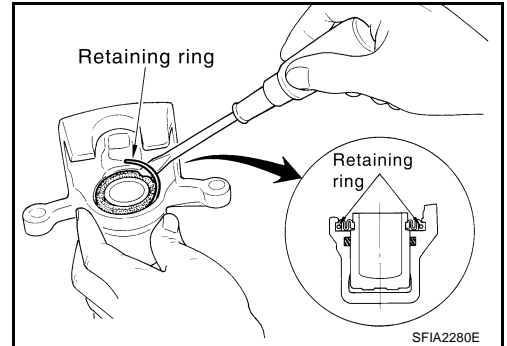

7. Install pad retainers to torque member.
8. After assembling shims and shim covers to pads, assemble it to torque member.
9. Install cylinder body, and tighten sliding pin bolts to the specified torque. Refer to [BR-29, "Components"](#).
10. Install brake hose to cylinder body and tighten union bolt to the specified torque. Refer to [BR-29, "Components"](#).

CAUTION:

- **Install a projection of brake hose metal fitting by aligning with protrusion on cylinder body.**

- **Do not reuse copper washer on union bolt.**

11. After installing caliper assembly, refill new brake fluid and bleed air. Refer to [BR-9, "BRAKE FLUID"](#).

DISC ROTOR INSPECTION

Visual Inspection

Check surfaces of disc rotor for uneven wear, cracks, and serious damage. If a malfunction is detected, replace applicable part.

Run Out Inspection

1. Using wheel nuts, fix the disc rotor to wheels hub. (2 or more positions)
2. Using a dial indicator, check run out.

Measurement point : At a point 10 mm (0.394 in) from outer edge of disc.

Run out limit : 0.07 mm (0.0028 in) or less

CAUTION:

Before measuring, make sure that axle end play is 0 mm.

3. If run out is outside limit, find minimum run out point by shifting mounting positions of disc rotor and wheel hub by one hole.

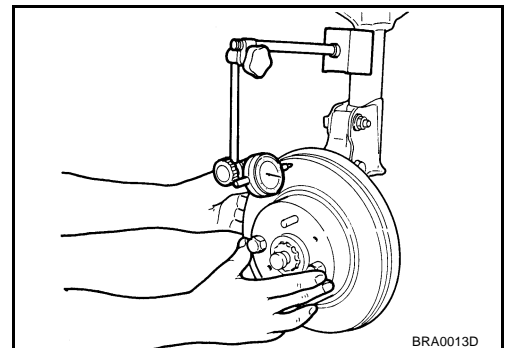

REAR DISC BRAKE

Thickness Inspection

Using a micrometer, check thickness of disc rotor. If thickness is outside standard, replace disc rotor.

Standard thickness	: 16.0 mm (0.630 in)
Wear limit	: 14.0 mm (0.551 in)
Maximum uneven wear (measured at 8 positions)	: 0.015 mm (0.0006 in) or less

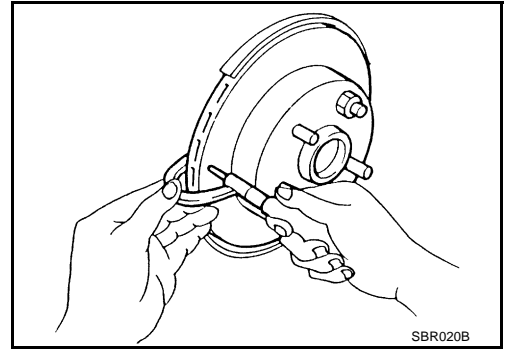

Brake Burnishing Procedure

NFS000C0

Burnish the brake pad or lining contact surfaces of rotor according to following procedure after refinishing or replacing drums or rotors, after replacing pads or linings, or if a soft pedal occurs at very low mileage.

CAUTION:

- **Be careful of vehicle speed because brake does not operate easily until pad and disc rotor are securely fitted.**
 - **Only perform this procedure under safe road and traffic conditions. Use extreme caution.**
1. Drive vehicle on straight, flat road.
 2. Depress brake pedal with the power to stop vehicle within 3 to 5 seconds until the vehicle stops.
 3. Drive without depressing brake for a few minutes to cool brake.
 4. Repeat steps 1 to 3 until pad and disc rotor are securely fitted.

SERVICE DATA AND SPECIFICATIONS (SDS)

SERVICE DATA AND SPECIFICATIONS (SDS)

PPF:00030

General Specifications

NFS000C1

Unit: mm (in)

Front brake	Cylinder bore diameter		45.0 (1.77) × 2
	Pad Length × width × thickness		130.0 × 50.0 × 10.0 (5.91 × 1.97 × 0.394)
	Rotor outer diameter × thickness		290 × 28.0 (11.42 × 1.102)
Rear brake	Cylinder bore diameter		42.86 (1.687)
	Pad Length × width × thickness		99.0 × 33.2 × 9.8 (3.90 × 1.307 × 0.386)
	Rotor outer diameter × thickness		292 × 16.0 (11.50 × 0.630)
Master cylinder	Cylinder bore diameter		25.4 (1)
Control valve	Valve model		Electric brake force distribution
Brake booster	Diaphragm diameter	Primary	230 (9.06)
		Secondary	205 (8.07)
Recommended brake fluid			DOT 3

Brake Pedal

NFS000C2

Pedal play	3 – 11 mm (0.12 – 0.43 in)
Brake pedal height (from dash lower panel top surface)	192.4 – 202.4 mm (7.57 – 7.97 in)
Depressed pedal height [under a force of 490 N (50 kg, 110 lb) with engine running]	90 mm (3.54 in) or more
Clearance between stopper rubber and threaded end of stop lamp switch and ASCD cancel switch	0.74 – 1.96 mm (0.0291 – 0.0772 in)

Check Valve

NFS000C3

Vacuum leakage [at vacuum of -66.7 kPa (-500 mmHg, -19.69 inHg)]	Within 1.3 kPa (10 mmHg, 0.39 inHg) of vacuum for 15 seconds
---	--

Brake Booster Vacuum type

NFS000C4

Vacuum leakage [at vacuum of -66.7 kPa (-500 mmHg, -19.69 inHg)]	Within 3.3 kPa (25 mmHg, 0.98 inHg) of vacuum for 15 seconds
Input rod installation standard dimension	125 mm (4.92 in)

Front Disc Brake

NFS000C5

Brake pad	Standard thickness	10.0 mm (0.394 in)
	Repair limit thickness	2.0 mm (0.079 in)
Disc rotor	Standard thickness	28.0 mm (1.102 in)
	Repair limit thickness	26.0 mm (1.024 in)
	Run out limit	0.07 mm (0.0028 in) or less

Rear Disc Brake

NFS000C6

Brake pad	Standard thickness	9.8 mm (0.386 in)
	Repair limit thickness	2.0 mm (0.079 in)
Disc rotor	Standard thickness	16.0 mm (0.630 in)
	Repair limit thickness	14.0 mm (0.551 in)
	Run out limit	0.07 mm (0.0028 in) or less

SERVICE DATA AND SPECIFICATIONS (SDS)
