

SECTION **FSU**  
FRONT SUSPENSION

A  
B  
C  
D

**FSU**

CONTENTS

<b>PRECAUTION</b> .....	<b>2</b>	<b>INSTALLATION</b> .....	<b>9</b>	<b>F</b>
Caution .....	2	Disassembly and Assembly .....	10	
<b>PREPARATION</b> .....	<b>3</b>	DISASSEMBLY .....	10	<b>G</b>
Special Service Tools (SST) .....	3	INSPECTION AFTER DISASSEMBLY .....	11	
Commercial Service Tools .....	3	ASSEMBLY .....	11	<b>H</b>
<b>NOISE, VIBRATION AND HARSHNESS (NVH)</b>		<b>SUSPENSION ARM</b> .....	<b>13</b>	
<b>TROUBLESHOOTING</b> .....	<b>4</b>	Removal and Installation .....	13	<b>H</b>
NVH Troubleshooting Chart .....	4	REMOVAL .....	13	
<b>FRONT SUSPENSION ASSEMBLY</b> .....	<b>5</b>	INSPECTION AFTER REMOVAL .....	13	<b>I</b>
On-Vehicle Inspection and Service .....	5	INSTALLATION .....	14	
INSPECTION LOWER BALL JOINT END PLAY....	5	<b>STABILIZER BAR</b> .....	<b>15</b>	<b>J</b>
STRUT INSPECTION .....	5	Removal and Installation .....	15	
Wheel Alignment Inspection .....	5	REMOVAL .....	15	<b>J</b>
DESCRIPTION .....	5	INSPECTION AFTER REMOVAL .....	15	
PRELIMINARY CHECK .....	5	INSTALLATION .....	15	<b>K</b>
GENERAL INFORMATION AND RECOMMEN-		<b>FRONT SUSPENSION MEMBER</b> .....	<b>16</b>	
DATIONS .....	5	Removal and Installation .....	16	<b>L</b>
THE ALIGNMENT PROCESS .....	6	REMOVAL .....	16	
INSPECTION OF CAMBER, CASTER AND		INSPECTION AFTER REMOVAL .....	16	<b>L</b>
KINGPIN INCLINATION ANGLES .....	6	INSTALLATION .....	16	<b>M</b>
Components .....	7	<b>SERVICE DATA AND SPECIFICATIONS (SDS) .....</b>	<b>17</b>	
<b>COIL SPRING AND STRUT</b> .....	<b>8</b>	Wheel Alignment (Unladen*) .....	17	
Removal and Installation .....	8	Ball Joint .....	17	
REMOVAL .....	8	Wheelarch Height (Unladen*) .....	17	

# PRECAUTION

---

## PRECAUTION

PFP:00001

### Caution

*NES00061*

- When installing rubber bushings, the final tightening must be carried out under unladen conditions with tires on ground. Oil will shorten the life of rubber bushings. Be sure to wipe off any spilled oil.
- Unladen conditions mean that fuel, engine coolant and lubricant are full. A spare tire, a jack, hand tools and mats are in designated positions.
- After servicing suspension parts, be sure to check wheel alignment.
- Self-lock nuts are not reusable. Always use new ones when installing. Since new caulking nuts are pre-oiled, tighten as they are.

# PREPARATION

## PREPARATION

PFP:00002

### Special Service Tools (SST)

NES00062

The actual shapes of Kent-Moore tools may differ from those of special service tools illustrated here.

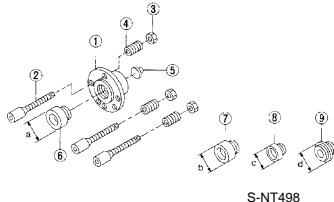
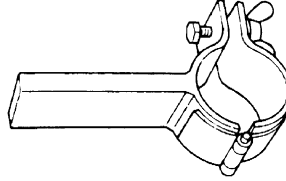
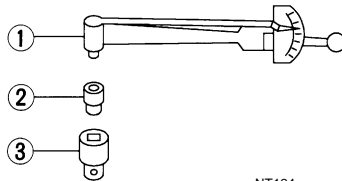
Tool number (Kent-Moore No.) Tool name	Description
KV991040S0 (    —    ) CCK gauge attachment 1. Plate 2. Guide bolts 3. Nuts 4. Springs 5. Center plate 6. KV99104020 Adapter A a: 72 mm (2.83 in) dia. 7. KV99104030 Adapter B b: 65 mm (2.56 in) dia. 8. KV99104040 Adapter C c: 57 mm (2.24 in) dia. 9. KV99104050 Adapter D d: 53.4 mm (2.102 in) dia.	 <p style="text-align: center;">S-NT498</p> <p>Measuring wheel alignment</p>
ST35652000 (    —    ) Strut attachment	 <p style="text-align: center;">ZZA0807D</p> <p>Disassembling and assembling strut</p>
ST3127S000 (See J-25765-A) Preload gauge 1. GG91030000 Torque wrench (J-25765) 2. HT62940000 ( — ) Socket adapter (1/2") 3. HT62900000 ( — ) Socket adapter (3/8")	 <p style="text-align: center;">NT124</p> <p>Measuring rotating torque of ball joint</p>

## Commercial Service Tools

NES00063

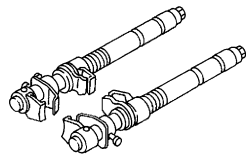
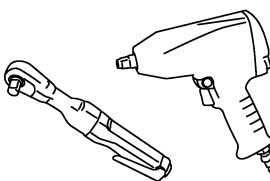
Tool name	Description
Spring compressor	 <p style="text-align: center;">S-NT717</p> <p>Removing coil spring</p>
Power tool	 <p style="text-align: center;">PBIC0190E</p> <ul style="list-style-type: none"> <li>● Removing wheel nuts</li> <li>● Removing undercover</li> <li>● Removing brake caliper assembly</li> <li>● Removing suspension components parts</li> </ul>

# NOISE, VIBRATION AND HARSHNESS (NVH) TROUBLESHOOTING

## NOISE, VIBRATION AND HARSHNESS (NVH) TROUBLESHOOTING

PF0:00003

### NVH Troubleshooting Chart

NES00064

Use chart below to help you find the cause of the symptom. If necessary, repair or replace these parts.

Symptom		Possible cause and SUSPECTED PARTS	Reference page																
			FSU-7	FSU-11	—	—	—	FSU-7	FSU-5	FSU-15	NVH in PR section	NVH in RFD section.	NVH in FAX and FSU sections.	NVH in WT section.	NVH in WT section.	NVH in RAX section.	NVH in BR section.	NVH in PS section.	
Symptom	FRONT SUSPENSION	Noise	x	x	x	x	x	x			x	x	x	x	x	x	x	x	
		Shake	x	x	x	x		x			x		x	x	x	x	x	x	
		Vibration	x	x	x	x	x				x		x	x		x		x	
		Shimmy	x	x	x	x			x				x	x	x		x	x	
		Judder	x	x	x								x	x	x		x	x	
		Poor quality ride or handling	x	x	x	x	x		x	x				x	x	x			
		Improper installation, looseness																	
		Strut deformation, damage or deflection																	
		Bushing or mounting deterioration																	
		Parts interference																	
		Spring fatigue																	
		Suspension looseness																	
		Incorrect wheel alignment																	
		Stabilizer bar fatigue																	
		PROPELLER SHAFT																	
		DIFFERENTIAL																	
		FRONT AXLE AND FRONT SUSPENSION																	
		TIRES																	
		ROAD WHEELS																	
		DRIVE SHAFT																	
		BRAKES																	
		STEERING																	

x: Applicable

# FRONT SUSPENSION ASSEMBLY

## FRONT SUSPENSION ASSEMBLY

PPF:54010

### On-Vehicle Inspection and Service

NES00065

Make sure the mounting conditions (looseness, back lash) of each component and component conditions (wear, damage) are normal.

#### INSPECTION LOWER BALL JOINT END PLAY

1. Set front wheels in a straight-ahead position. Do not depress brake pedal.
2. Place an iron bar or similar tool between transverse link and steering knuckle.
3. Measure axial end play by prying it up and down.

**Axial end play : 0 mm (0 in)**

#### **CAUTION:**

**Be careful not to damage ball joint boot.**

#### STRUT INSPECTION

- Check strut for oil leakage, damage and replace if there are. Refer to [FSU-8, "COIL SPRING AND STRUT"](#).

#### Wheel Alignment Inspection DESCRIPTION

NES000HL

- Measure wheel alignment under unladen conditions.

#### **NOTE:**

Unladen conditions mean that fuel, engine coolant, and lubricant are full. Spare tire, jack, hand tools and mats are designated positions.

#### PRELIMINARY CHECK

- Check tires for improper air pressure and wear.
- Check road wheels for runout.
- Check wheel bearing axial end play.
- Check ball joint axial end play of compression rod, upper link, and steering knuckle
- Check shock absorber operation.
- Check each mounting part of axle and suspension for looseness and deformation.
- Check each link, rod and member for cracks, deformation and other damage.
- Check vehicle posture.

#### GENERAL INFORMATION AND RECOMMENDATIONS

- A four-wheel thrust alignment should be performed.
  - This type of alignment is recommended for any NISSAN/INFINITI vehicle.
  - The four-wheel "thrust" process helps ensure that the vehicle is properly aligned and the steering wheel is centered.
  - The alignment rack itself should be capable of accepting any NISSAN/INFINITI vehicle.
  - The rack should be checked to ensure that it is level.
- Make sure the machine is properly calibrated.
  - Your alignment equipment should be regularly calibrated in order to give correct information.
  - Check with the manufacturer of your specific equipment for their recommended Service/Calibration Schedule.

# FRONT SUSPENSION ASSEMBLY

## THE ALIGNMENT PROCESS

### IMPORTANT:

Use only the alignment specifications listed in this Service Manual.

- When displaying the alignment settings, many alignment machines use “indicators”: (Green/red, plus or minus, Go/No Go). **Do NOT use these indicators.**
- The alignment specifications programmed into your machine that operate these indicators may not be correct.
- This may result in an ERROR.
- Some newer alignment machines are equipped with an optional “Rolling Compensation” method to “compensate” the sensors (alignment targets or head units). **DO NOT use this “Rolling Compensation” method.**
- Use the “Jacking Compensation Method”. After installing the alignment targets or head units, raise the vehicle and rotate the wheels 1/2 turn both ways.
- See Instructions in the alignment machine you're using for more information on this.

## INSPECTION OF CAMBER, CASTER AND KINGPIN INCLINATION ANGLES

- Camber, caster, kingpin inclination angles cannot be adjusted.
- Before inspection, mount front wheels onto turning radius gauge. Mount rear wheels onto a stand that has same height so vehicle will remain horizontal.

### Using a CCK Gauge

Install CCK gauge attachment [SST: KV991040S0 ( - )] as following procedure in wheel, then measure wheel alignment.

1. Remove wheel nuts (2), and install a guide bolts to hub bolts.
2. Screw adapter into plate body until it contacts plate tightly.
3. Screw center plate into plate.
4. Insert plate on guide bolts. Put spring in, and then evenly screw both guide bolt nuts. When fastening guide nuts, do not completely compress springs.

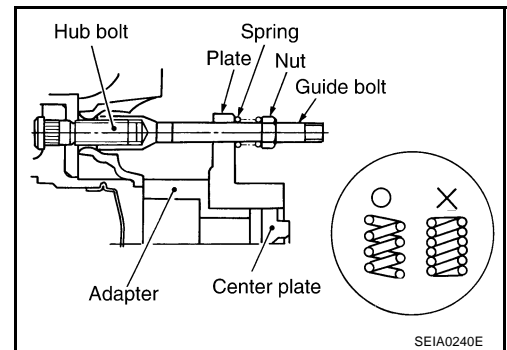

5. Place the dent of alignment gauge onto the projection of center plate and tightly contact them to measure.

#### Standard value

#### Camber, caster, kingpin inclination angles:

Refer to [FSU-17, "SERVICE DATA AND SPECIFICATIONS \(SDS\)"](#) .

#### CAUTION:

- If camber, caster, or kingpin inclination angle is outside the standard, check front suspension parts for wear and damage, and replace suspect parts if necessary.
- King pin inclination angle is reference value, no inspection is required. (Due to the type of suspension, the kingpin inclination angle cannot be measured correctly using a normal alignment tester.)

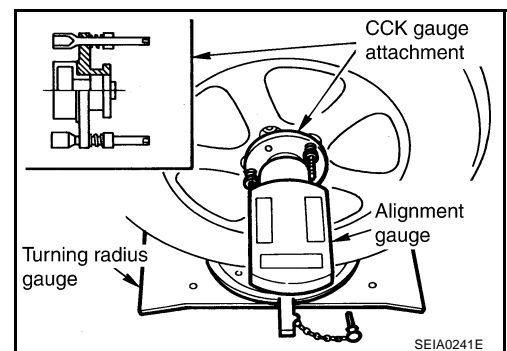

# FRONT SUSPENSION ASSEMBLY

## Components

NES000HM

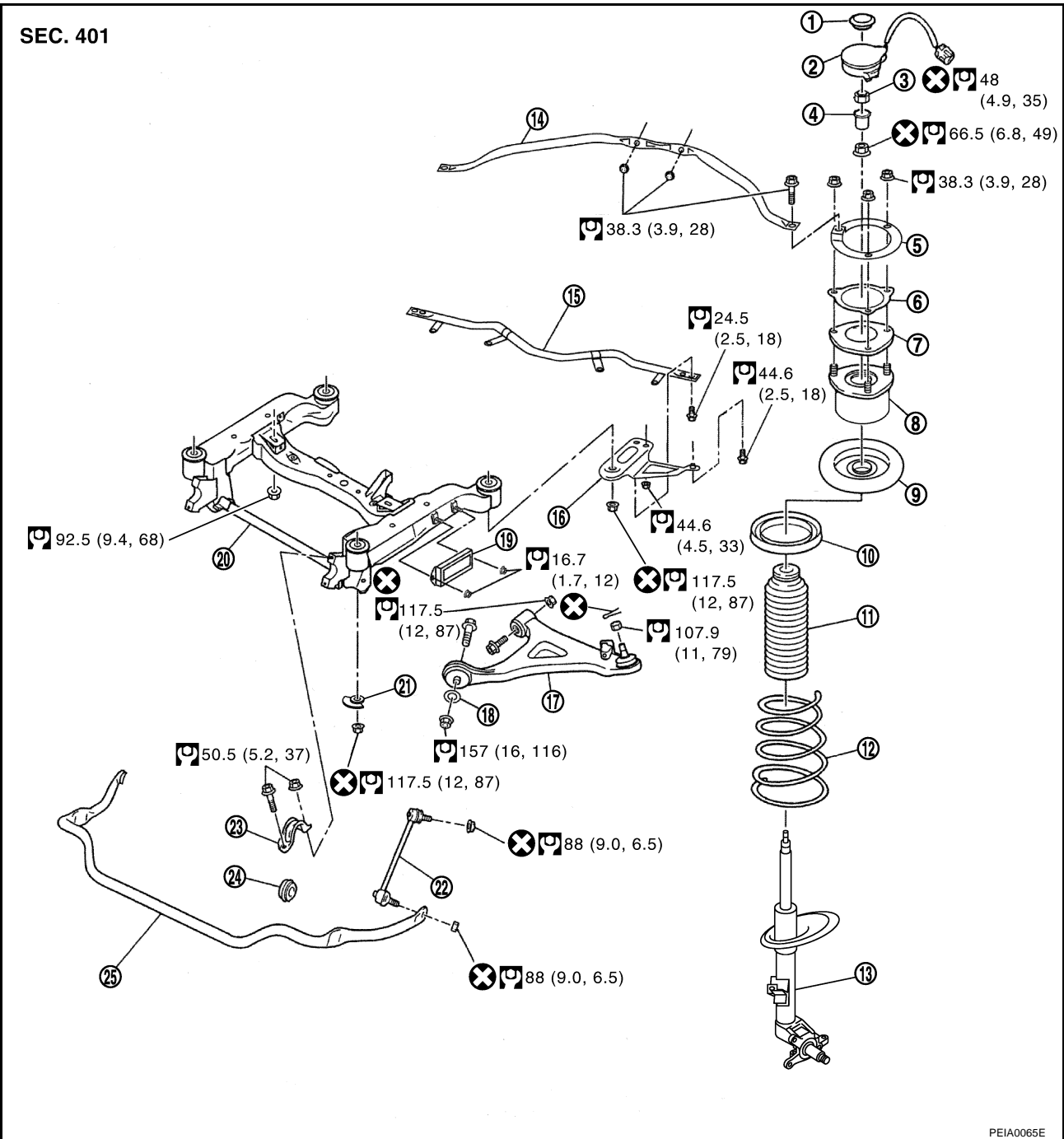

- |   |  |  |
|---|--|--|
| 1. Cap (Without active damper suspension)         | 2. Actuator assembly (With active damper suspension) | 3. Nut (With active damper suspension) |
| 4. Actuator plate (With active damper suspension) | 5. Tower bar bracket                                 | 6. Spacer                              |
| 7. Strut mounting insulator bracket               | 8. Strut mounting insulator assembly                 | 9. Spring upper seat                   |
| 10. Upper rubber seat                             | 11. Bound bumper                                     | 12. Coil spring                        |
| 13. Strut assembly                                | 14. Tower bar  | 15. Front cross bar                    |
| 16. Member stay                                   | 17. Suspension arm                                   | 18. Washer                             |
| 19. Dynamic damper                                | 20. Front suspension member                          | 21. Rebound stopper                    |
| 22. Stabilizer connecting rod                     | 23. Stabilizer clamp                                 | 24. Stabilizer bushing                 |
| 25. Stabilizer bar                                |  |  |

Refer to [Gl-9. "Components"](#), for the symbols in the figure.

# COIL SPRING AND STRUT

PFP:55302

NES00068

## COIL SPRING AND STRUT

### Removal and Installation

#### REMOVAL

1. Remove tires from vehicle with power tool.
2. Remove brake caliper with power tool. Hang it in a place where it will not interfere with work. Refer to [BR-23, "FRONT DISC BRAKE"](#).

#### NOTE:

Avoid depressing brake pedal while brake caliper is removed.

3. Remove mounting nuts of brake hose from strut assembly.

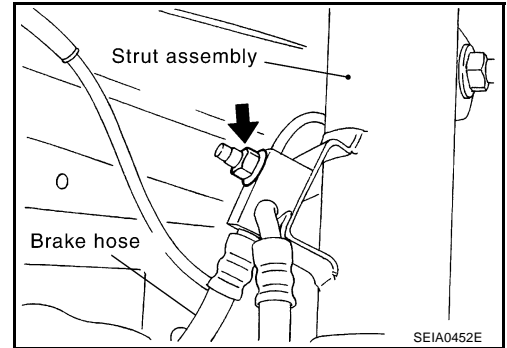

4. Remove harness of wheel sensor from strut assembly. Refer to [BRC-63, "WHEEL SENSORS"](#).

#### CAUTION:

Do not pull on wheel sensor harness.

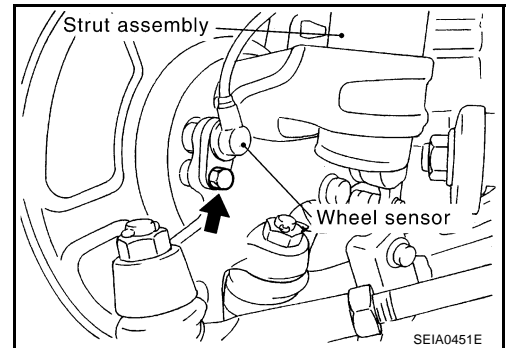

5. Remove stabilizer connecting rod upper nut, separate strut assembly and stabilizer connecting rod.
6. Remove steering outer socket and cotter pin at steering knuckle, then loosen mounting nut.

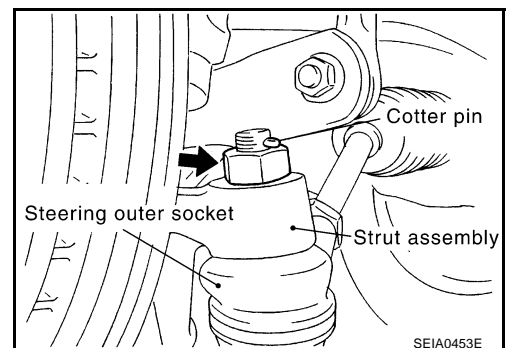

7. Use a ball joint remover (suitable tool) to remove steering outer socket from steering knuckle. Be careful not to damage ball joint boot.

#### CAUTION:

Tighten temporarily mounting nut to prevent damage to threads and to prevent the ball joint remover (suitable tool) from coming off.

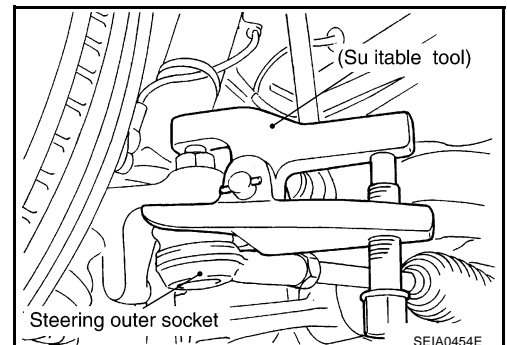



# COIL SPRING AND STRUT

8. Remove cotter pin of suspension arm ball joint, then loosen mounting nut.
9. Use a ball joint remover (suitable tool) to remove strut assembly from suspension arm. Be careful not to damage ball joint boot.

**CAUTION:**

**Tighten temporarily mounting nut to prevent damage to threads and to prevent the ball joint remover (suitable tool) from coming off.**

10. Turn actuator assembly to the left, and remove it from actuator plate.(without active damper suspension)
11. Remove cap from assembly (without active damper suspension)
12. Remove mounting bolts of tower bar, and then remove tower bar from vehicle
13. Remove mounting nuts of strut mounting insulator assembly, and then remove strut assembly from vehicle

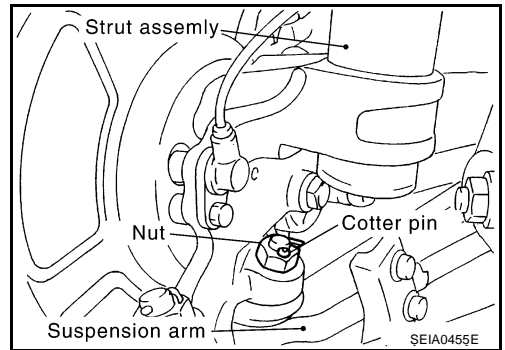

A  
B  
C  
D

FSU

## INSTALLATION

- Refer to [FSU-7, "Components"](#) for tightening torque. Install in the reverse order of the removal.

**NOTE:**

Refer to component parts location and do not reuse non-reusable parts.

- After removing/installing or replacing suspension components, check wheel alignment. Refer to [FSU-5, "Wheel Alignment Inspection"](#).
- After adjusting wheel alignment, adjust neutral position of steering angle sensor. Refer to [BRC-6, "Adjustment of Steering Angle Sensor Neutral Position"](#).
- Make sure actuator plate fits tightly into actuator assembly.
- Make sure actuator assembly is installed as shown in the figure.(without active damper suspension)

**CAUTION:**

**If actuator assembly is subjected to damage drop, do not use it.**

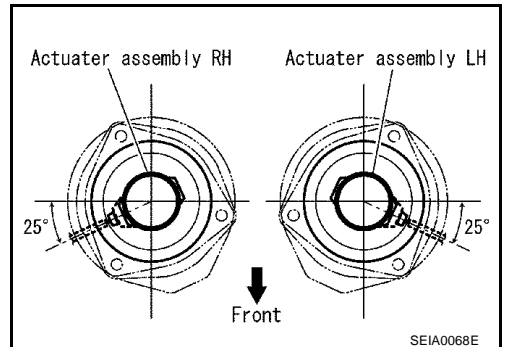

F  
G  
H  
I  
J  
K  
L  
M

- Attach strut mounting insulator bracket as shown in the figure.

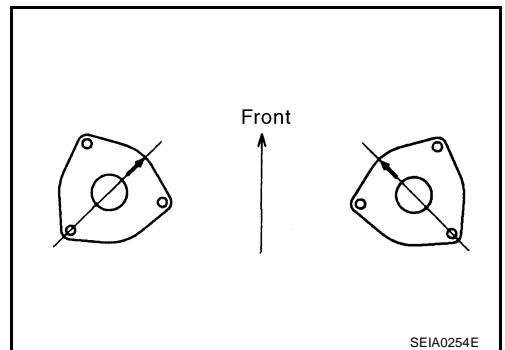

# COIL SPRING AND STRUT

NES00069

## Disassembly and Assembly DISASSEMBLY

### CAUTION:

Do not damage piston rod on strut assembly when removing components from strut assembly.

1. Fix strut mounting insulator assembly and remove actuator plate fixing nut, then remove actuator plate from strut assembly. (with active damper suspension)

### CAUTION:

Be careful not to deform actuator plate and strut mounting insulator.

2. Install the strut attachment (SST) to strut assembly and secure it in a vice.

### CAUTION:

Wrap a shop cloth around strut assembly to protect it from damage, when installing the strut attachment (SST) to strut assembly.

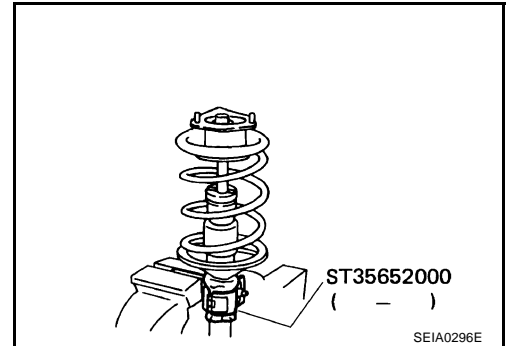

3. Compress coil spring using a spring compressor (commercial service tool) until coil spring is free.

### CAUTION:

Be sure spring compressor (commercial service tool) is securely attached to coil spring before coil spring is compressed. Compress coil spring.

4. After making sure coil spring with a spring compressor is free between upper rubber seat and lower rubber seat of strut assembly. Remove piston rod lock nut.
5. Remove strut mounting bracket, strut mounting insulator assembly, spring upper seat, upper rubber seat, coil spring with spring compressor and bound bumper from strut assembly.

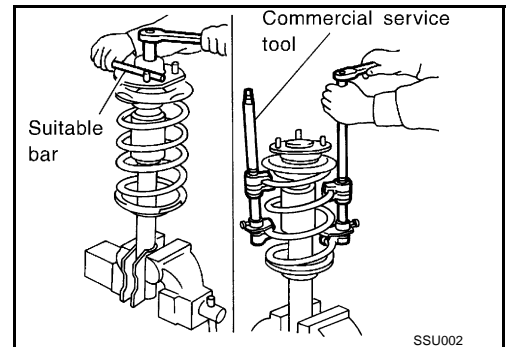

6. Gradually release spring compressor (commercial service tool), and remove coil spring.

### CAUTION:

Loosen spring compressor while making sure coil spring attachment position does not move.

7. Remove lower rubber seat from strut assembly.
8. Remove the strut attachment (SST) from strut assembly.

# COIL SPRING AND STRUT

## INSPECTION AFTER DISASSEMBLY

### Strut Inspection

Check the followings

- Strut assembly for deformation, cracks, damage, and replace if necessary.
- Piston rod for damage, uneven wear or distortion, and replace if necessary.
- Welded and sealed areas for oil leakage, and replace if necessary.

### Strut Mounting Insulator and Rubber Parts Inspection

Check mounting insulator, mounting insulator bracket for cracks and rubber parts for wear. Replace them if necessary.

### Coil Spring Inspection

Check coil spring for cracks, wear or damage and replace if necessary.

## ASSEMBLY

### NOTE:

Make sure strut piston rod is not damaged when attaching components to strut assembly.

1. Install strut attachment (SST) to strut assembly and secure it in a vise.

### CAUTION:

**When installing the strut attachment (SST) to strut assembly, wrap a shop cloth around strut assembly to protect it from damage.**

2. Install lower rubber seat to strut assembly.

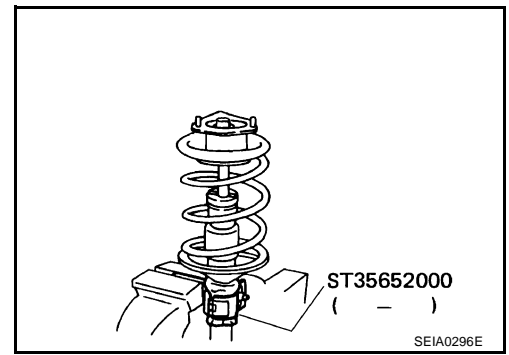

3. Compress coil spring using a spring compressor (commercial service tool), and install it onto strut assembly.

### CAUTION:

- Face the tube side of coil spring downward. Align lower end to spring seat as shown in the figure.
- Be sure spring compressor (commercial service tool) is securely attached to coil spring. And then compress coil spring.

4. Apply soapy water to bound bumper, Insert bound bumper into spring upper seat, and then install it to strut together with upper rubber seat.

### CAUTION:

- Do not use machine oil.
- Installation position of spring upper seat as shown in the figure.

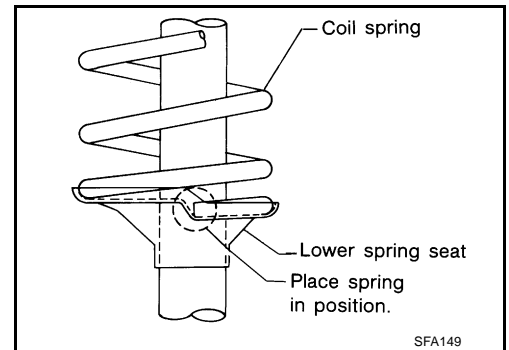

5. Install strut mounting insulator assembly, strut mounting bracket and gasket to strut.

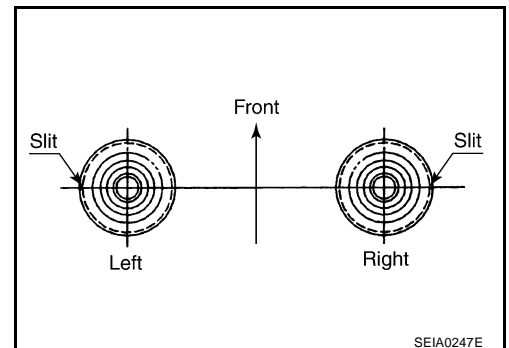

A  
B  
C  
D

FSU

F  
G  
H  
I  
J  
K  
L  
M

## COIL SPRING AND STRUT

6. Fix strut mounting insulator, then tighten piston rod lock nut with the specified torque.

**CAUTION:**

**Be careful not to deform strut mounting insulator.**

7. Gradually release spring compressor (commercial service tool), and remove coil spring.

**CAUTION:**

**Loosen spring compressor while making sure coil spring attachment position does not move.**

8. Remove strut attachment (SST) from strut assembly.
9. Install actuator plate onto strut assembly.(with active damper suspension)
10. Fix strut mounting insulator, then tighten actuator plate fixing nut with the specified torque.(with active damper suspension)

**CAUTION:**

**Be careful not to deform actuator plate and strut mounting insulator.**

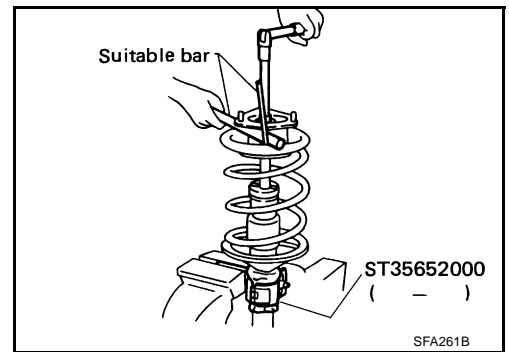

# SUSPENSION ARM

## SUSPENSION ARM

PPF:55501

### Removal and Installation

NES0006A

#### REMOVAL

1. Remove tires from vehicle with power tool.
2. Remove undercover with power tool.
3. Remove cotter pin of suspension arm and strut assembly, and then loosen nut.
4. Use the ball joint remover (suitable tool) to remove suspension arm from strut assembly. Be careful not to damage ball joint boot.

#### CAUTION:

**Tighten temporarily mounting nut to prevent damage to threads and to prevent the ball joint remover (suitable tool) from coming off.**

5. Remove fixing bolts, washer and nuts then remove suspension arm from vehicle.

#### INSPECTION AFTER REMOVAL

##### Visual Inspection

- Check suspension arm and bushing for deformation, cracks, or damage. If any non-standard condition is found, replace it.
- Check boot of ball joint for cracks, or other damage, and also for grease leakage. If any non-standard condition is found, replace it.

##### Ball Joint Inspection

- Manually move ball stud to confirm it moves smoothly with no binding.

##### Swing Torque Inspection

#### NOTE:

Before measurement, move ball joint at least ten times by hand to check for smooth movement.

- Hook spring balance at cotter pin mounting hole. Confirm spring balance measurement value is within the specifications when ball stud begins moving.

#### Specified swing torque:

**0.5 - 3.4 N·m (0.06 - 0.34 kg·m, 5 - 30 in·lb)**

#### Specified value of spring balance:

**8.8 - 59.6 N (0.90 - 6.08 kg, 1.98 - 13.41 lb)**

- If it is outside the specified range, replace suspension arm assembly.

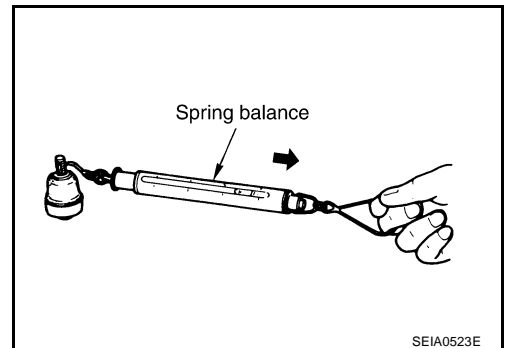

##### Rotating Torque Inspection

- Attach mounting nut to ball stud. Check that rotating torque is within the specifications with a preload gauge (SST).

#### Specified rotating torque:

**0.5 - 3.4 N·m (0.06 - 0.34 kg·m, 5 - 30 lb)**

- If it is outside the specified range, replace suspension arm assembly.

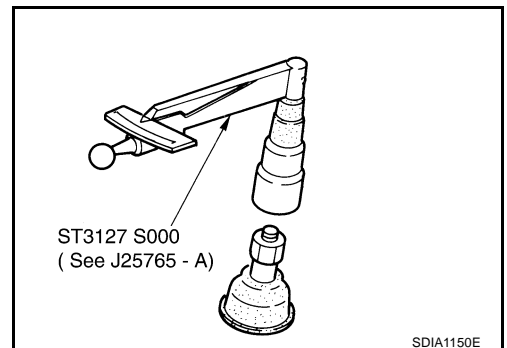

##### Axial End Play Inspection

- Move the tip of ball joint in the axial direction to check for looseness.

**Specified axial end play : 0 mm (0 in)**

- If it is outside the specified range, replace suspension arm assembly.

A  
B  
C  
D  
FSU  
F  
G  
H  
I  
J  
K  
L  
M

# SUSPENSION ARM

---

## INSTALLATION

- Refer to [FSU-7, "Components"](#) for tightening torque. Install in the reverse order of the removal.

**NOTE:**

Refer to component parts location and do not reuse non-reusable parts.

- After removing/installing or replacing suspension components, check wheel alignment. Refer to [FSU-5, "Wheel Alignment Inspection"](#) .
- After adjusting wheel alignment, adjust neutral position of steering angle sensor. Refer to [BRC-6, "Adjustment of Steering Angle Sensor Neutral Position"](#) .

# STABILIZER BAR

## STABILIZER BAR

PPF:56230

A

### Removal and Installation

NES0006B

#### REMOVAL

1. Remove tires from vehicle with power tool. B
2. Remove undercover with power tool. C
3. Remove the mounting nut on the lower side of stabilizer connecting rod with a power tool. D
4. If necessary remove mounting nut on the upper side of stabilizer connecting rod with power tool, and then remove stabilizer connecting rod from strut assembly. E
5. Remove stabilizer clamp mounting bolts and nuts with a power tool. F
6. Remove stabilizer bar from vehicle. G

#### INSPECTION AFTER REMOVAL

Check stabilizer bar, stabilizer connecting rod, stabilizer bushing and stabilizer clamp for deformation, cracks and damage, and replace if necessary. FSU

#### INSTALLATION

- Refer to [FSU-7, "Components"](#) for tightening torque. Install in the reverse order of removal. H
- **NOTE:**  
Refer to component parts location and do not reuse non-reusable parts. I
- After removing/installing or replacing suspension components, check wheel alignment. Refer to [FSU-5, "Wheel Alignment Inspection"](#). J
- After adjusting wheel alignment, adjust neutral position of steering angle sensor. Refer to [BRC-6, "Adjustment of Steering Angle Sensor Neutral Position"](#). K
- Stabilizer bar uses pillow ball type connecting rod. L

M

N

O

P

Q

# FRONT SUSPENSION MEMBER

## FRONT SUSPENSION MEMBER

PFP:54401

### Removal and Installation

NES0006C

#### REMOVAL

1. Remove tires from vehicle with power tool.
2. Remove undercover with power tool.
3. Remove steering hydraulic piping bracket from front suspension member. Refer to [PS-32, "HYDRAULIC LINE"](#) .
4. Remove steering gear and front suspension member attachment bolts and hang steering gear on vehicle. Refer to [PS-15, "POWER STEERING GEAR"](#) .
5. Remove suspension arm from front suspension member. Refer to [FSU-13, "SUSPENSION ARM"](#) .
6. Remove stabilizer bar mounting bolts and nuts from front suspension member then suspend a stabilizer on vehicle. Refer to [FSU-15, "STABILIZER BAR"](#) .
7. Remove cross bar from member stay. Refer to [FSU-7, "Components"](#) .
8. Set jack under front suspension member and engine.

#### **CAUTION:**

**When setting jack to engine, use a wooden block or an equivalent for the setting.**

9. Remove fixing bolts and nuts between engine mounting insulator and front suspension member. Refer to [EM-79, "ENGINE ASSEMBLY"](#) .
10. Remove member stay from front suspension member and body.
11. Remove mounting nuts front suspension member and body.
12. Slowly lower jack to remove front suspension member from vehicle.

#### INSPECTION AFTER REMOVAL

Check front suspension member for deformation, cracks, or any other damage. Replace if necessary.

#### INSTALLATION

- Refer to [FSU-7, "Components"](#) for tightening torque. Install in the reverse order of removal.

#### **NOTE:**

Refer to component parts location and do not reuse non-reusable parts.

- After removing/installing or replacing suspension components and steering components, check wheel alignment. Refer to [FSU-5, "Wheel Alignment Inspection"](#) .
- After adjusting wheel alignment, adjust neutral position of steering angle sensor. Refer to [BRC-6, "Adjustment of Steering Angle Sensor Neutral Position"](#) .



# SERVICE DATA AND SPECIFICATIONS (SDS)

## SERVICE DATA AND SPECIFICATIONS (SDS)

PFP:00030

### Wheel Alignment (Unladen\*)

NES0006D

Camber Degree minute (Decimal degree)	Minimum	-1°30' (-1.5°)	
	Nominal	-0°45' (-0.75°)	
	Maximum	0°00' (0.00°)	
	Left and right difference	45' (0.75°)	
Caster Degree minute (Decimal degree)	Minimum	5°25' (5.42°)	
	Nominal	6°10' (6.17°)	
	Maximum	6°55' (6.92°)	
	Left and right difference	45' (0.75°)	
Kingpin inclination Degree minute (Decimal degree)	Minimum	13°15' (13.25°)	
	Nominal	14°00' (14.00°)	
	Maximum	14°45' (14.75°)	
Total toe-in	Distance (A – B)	Nominal	1 mm (0.04 in)
		Minimum	0' (0°)
	Angle (left plus right) Decimal degree (Decimal degree)	Nominal	3' (0.05°)
		Maximum	6' (0.10°)

\*: Fuel, radiator coolant and engine oil full. Spare tire, jack, hand tools and mats in designated positions.

### Ball Joint

NES0006E

Swing torque	0.5 – 3.4 N·m (0.06 – 0.34 kg·m, 5 – 30 in·lb)
Measurement on spring balance (cotter pinhole position)	8.8 – 59.6 N (0.90 – 6.08 kg, 1.98 – 13.41 lb)
Rotating torque	0.5 – 3.4 N·m (0.06 – 0.34 kg·m, 5 – 30 in·lb)
Axial end play	0 mm (0 in)

### Wheelarch Height (Unladen\*)

NES0006F

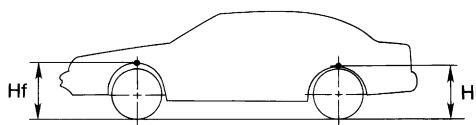

SFA818A

Tire	225/55R17	225/55R17 (Runflat tire)	245/45R18	245/40R19
Front (Hf)	730 mm (28.74 in)	734 mm (28.90 in)	726 mm (28.58 in)	729 mm (28.70 in)
Rear (Hr)	704 mm (27.72 in) [USA model]	707 mm (27.83 in) [USA model]	700 mm (27.56 in) [USA model]	703 mm (27.68 in)
	705 mm (27.76 in) [Canada model]	708 mm (27.87 in) [Canada model]	701 mm (27.60 in) [Canada model]	

\*: Fuel, radiator coolant and engine oil full. Spare tire, jack, hand tools and mats in designated positions.

# SERVICE DATA AND SPECIFICATIONS (SDS)

---