

A

ACC

SECTION ACC

ACCELERATOR CONTROL SYSTEM

C

CONTENTS

D

E

PRECAUTION 2	ON-VEHICLE REPAIR 3	F
PRECAUTIONS 2	ACCELERATOR CONTROL SYSTEM 3	
Precaution for Supplemental Restraint System (SRS) "AIR BAG" and "SEAT BELT PRE-TENSIONER"2	Exploded View 3	G
	Removal and Installation 3	
	Inspection 3	H

I

J

K

L

M

N

O

P

PRECAUTIONS

< PRECAUTION >

PRECAUTION

PRECAUTIONS

Precaution for Supplemental Restraint System (SRS) "AIR BAG" and "SEAT BELT PRE-TENSIONER"

INFOID:000000001179351

The Supplemental Restraint System such as "AIR BAG" and "SEAT BELT PRE-TENSIONER", used along with a front seat belt, helps to reduce the risk or severity of injury to the driver and front passenger for certain types of collision. This system includes seat belt switch inputs and dual stage front air bag modules. The SRS system uses the seat belt switches to determine the front air bag deployment, and may only deploy one front air bag, depending on the severity of a collision and whether the front occupants are belted or unbelted. Information necessary to service the system safely is included in the "SRS AIRBAG" and "SEAT BELT" of this Service Manual.

WARNING:

- To avoid rendering the SRS inoperative, which could increase the risk of personal injury or death in the event of a collision which would result in air bag inflation, all maintenance must be performed by an authorized NISSAN/INFINITI dealer.
- Improper maintenance, including incorrect removal and installation of the SRS, can lead to personal injury caused by unintentional activation of the system. For removal of Spiral Cable and Air Bag Module, see the "SRS AIRBAG".
- Do not use electrical test equipment on any circuit related to the SRS unless instructed to in this Service Manual. SRS wiring harnesses can be identified by yellow and/or orange harnesses or harness connectors.

ACCELERATOR CONTROL SYSTEM

< ON-VEHICLE REPAIR >

ON-VEHICLE REPAIR

ACCELERATOR CONTROL SYSTEM

Exploded View

INFOID:000000001179352

A

ACC

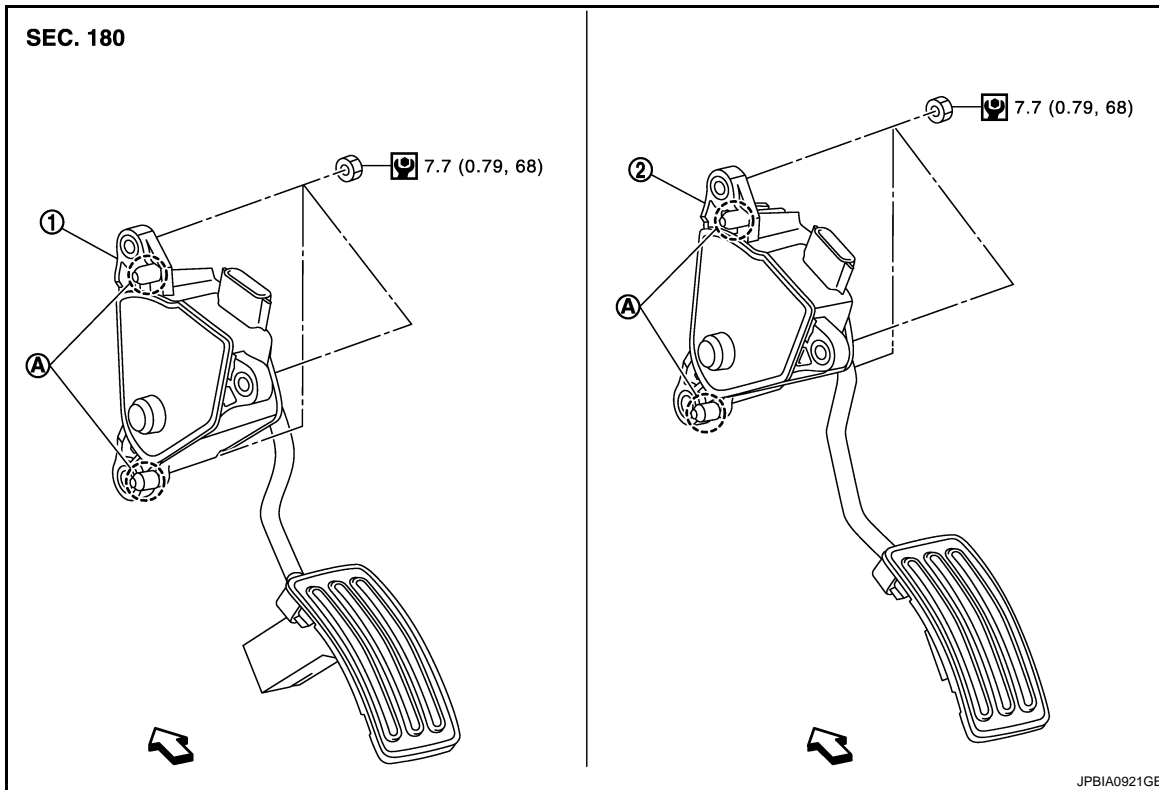

C

D

E

F

G

H

I

J

K

L

M

N

O

P

1. Accelerator pedal assembly (LHD models) 2. Accelerator pedal assembly (RHD models)

A. Locating pin

↔ : Vehicle front

Refer to [GI-4. "Components"](#) for symbols in the figure.

Removal and Installation

INFOID:000000001179353

REMOVAL

1. Loosen mounting nuts, and remove accelerator pedal assembly.

CAUTION:

- Never disassemble accelerator lever. Never remove accelerator pedal position sensor from accelerator lever.
- Avoid impact from dropping etc. during handling.
- Be careful to keep accelerator lever away from water.

2. Disconnect accelerator pedal position sensor harness connector.

INSTALLATION

Note the following, and install in the reverse order of removal.

- Insert locating pin into vehicle side to position accelerator pedal assembly. Install mounting bolt to accelerator pedal assembly.

Inspection

INFOID:000000001179354

INSPECTION AFTER INSTALLATION

- Make sure that the accelerator pedal moves smoothly within the whole operation range when it is fully depressed and released.

ACCELERATOR CONTROL SYSTEM

< ON-VEHICLE REPAIR >

NOTE:

On A/T and CVT models, the accelerator pedal becomes stiffer and will “click” at 75 % stroke. This is not a malfunction.

- Make sure accelerator pedal securely returns to the fully released position.
- For the electrical inspection of accelerator pedal position sensor. Refer to the following.

HR16DE : [ECH-268, "Description"](#).

MR20DE : [ECM-528, "Description"](#).

M9R : [ECR-158, "Description"](#).

K9K : [ECK-106, "Description"](#).