

SECTION **FSU**
FRONT SUSPENSION

A
B
C
D
F
G
H
I
J
K
L
M
N
O
P

FSU

CONTENTS

SYMPTOM DIAGNOSIS	2	Removal and Installation	10
NOISE, VIBRATION AND HARSHNESS (NVH) TROUBLESHOOTING	2	Disassembly and Assembly	10
NVH Troubleshooting Chart	2	Inspection	12
PRECAUTION	3	TRANSVERSE LINK	13
PRECAUTIONS	3	Exploded View	13
Precaution for Supplemental Restraint System (SRS) "AIR BAG" and "SEAT BELT PRE-TENSIONER"	3	Removal and Installation	14
Precaution Necessary for Steering Wheel Rotation After Battery Disconnect	3	Inspection	14
Precaution for Procedure without Cowl Top Cover.....	4	FRONT STABILIZER	16
Precautions for Suspension	4	Exploded View	16
PREPARATION	5	Removal and Installation	17
PREPARATION	5	Inspection	17
Special Service Tool	5	FRONT SUSPENSION MEMBER	18
Commercial Service Tool	5	Exploded View	18
ON-VEHICLE MAINTENANCE	6	Removal and Installation	19
FRONT SUSPENSION ASSEMBLY	6	Inspection	19
Inspection	6	REMOVAL AND INSTALLATION	20
WHEEL ALIGNMENT	7	FRONT SUSPENSION ASSEMBLY	20
Wheel Alignment Inspection	7	Exploded View	20
ON-VEHICLE REPAIR	9	Removal and Installation	21
FRONT COIL SPRING AND STRUT	9	Inspection	21
Exploded View	9	SERVICE DATA AND SPECIFICATIONS (SDS)	22
		SERVICE DATA AND SPECIFICATIONS (SDS)	22
		Wheel Alignment	22
		Ball Joint	22
		Wheel Height	22

NOISE, VIBRATION AND HARSHNESS (NVH) TROUBLESHOOTING

< SYMPTOM DIAGNOSIS >

SYMPTOM DIAGNOSIS

NOISE, VIBRATION AND HARSHNESS (NVH) TROUBLESHOOTING

NVH Troubleshooting Chart

INFOID:000000001181399

Use chart below to find the cause of the symptom. If necessary, repair or replace these parts.

		FSU-20	FSU-12	—	—	—	FSU-20	FSU-22	FSU-17	NVH in DLN section	NVH in DLN section	NVH in FAX and FSU sections	NVH in WT section	NVH in WT section	NVH in FAX section	NVH in BR section	NVH in ST section	
Reference page		FSU-20	FSU-12	—	—	—	FSU-20	FSU-22	FSU-17	NVH in DLN section	NVH in DLN section	NVH in FAX and FSU sections	NVH in WT section	NVH in WT section	NVH in FAX section	NVH in BR section	NVH in ST section	
Possible cause and SUSPECTED PARTS		Improper installation, looseness	Shock absorber deformation, damage or deflection	Bushing or mounting deterioration	Parts interference	Spring fatigue	Suspension looseness	Incorrect wheel alignment	Stabilizer bar fatigue	PROPELLER SHAFT (4WD)	DIFFERENTIAL (4WD)	FRONT AXLE AND FRONT SUSPENSION	TIRE	ROAD WHEEL	DRIVE SHAFT	BRAKE	STEERING	
Symptom	FRONT SUSPENSION	Noise	x	x	x	x	x			x	x	x	x	x	x	x	x	
		Shake	x	x	x	x		x			x		x	x	x	x	x	
		Vibration	x	x	x	x	x				x		x	x		x		x
		Shimmy	x	x	x	x			x				x	x	x		x	x
		Judder	x	x	x								x	x	x		x	x
		Poor quality ride or handling	x	x	x	x	x		x	x			x	x	x			

x: Applicable

PRECAUTIONS

< PRECAUTION >

PRECAUTION

PRECAUTIONS

Precaution for Supplemental Restraint System (SRS) "AIR BAG" and "SEAT BELT PRE-TENSIONER"

INFOID:000000001181400

The Supplemental Restraint System such as "AIR BAG" and "SEAT BELT PRE-TENSIONER", used along with a front seat belt, helps to reduce the risk or severity of injury to the driver and front passenger for certain types of collision. This system includes seat belt switch inputs and dual stage front air bag modules. The SRS system uses the seat belt switches to determine the front air bag deployment, and may only deploy one front air bag, depending on the severity of a collision and whether the front occupants are belted or unbelted. Information necessary to service the system safely is included in the "SRS AIRBAG" and "SEAT BELT" of this Service Manual.

WARNING:

- To avoid rendering the SRS inoperative, which could increase the risk of personal injury or death in the event of a collision which would result in air bag inflation, all maintenance must be performed by an authorized NISSAN/INFINITI dealer.
- Improper maintenance, including incorrect removal and installation of the SRS, can lead to personal injury caused by unintentional activation of the system. For removal of Spiral Cable and Air Bag Module, see the "SRS AIRBAG".
- Do not use electrical test equipment on any circuit related to the SRS unless instructed to in this Service Manual. SRS wiring harnesses can be identified by yellow and/or orange harnesses or harness connectors.

Precaution Necessary for Steering Wheel Rotation After Battery Disconnect

INFOID:000000001181401

NOTE:

- This Procedure is applied only to models with Intelligent Key system and NATS (NISSAN ANTI-THEFT SYSTEM).
- Remove and install all control units after disconnecting both battery cables with the ignition knob in the "LOCK" position.
- Always use CONSULT-III to perform self-diagnosis as a part of each function inspection after finishing work. If DTC is detected, perform trouble diagnosis according to self-diagnostic results.

For models equipped with the Intelligent Key system and NATS, an electrically controlled steering lock mechanism is adopted on the key cylinder.

For this reason, if the battery is disconnected or if the battery is discharged, the steering wheel will lock and steering wheel rotation will become impossible.

If steering wheel rotation is required when battery power is interrupted, follow the procedure below before starting the repair operation.

OPERATION PROCEDURE

1. Connect both battery cables.

NOTE:

Supply power using jumper cables if battery is discharged.

2. Use the Intelligent Key or mechanical key to turn the ignition switch to the "ACC" position. At this time, the steering lock will be released.
3. Disconnect both battery cables. The steering lock will remain released and the steering wheel can be rotated.
4. Perform the necessary repair operation.
5. When the repair work is completed, return the ignition switch to the "LOCK" position before connecting the battery cables. (At this time, the steering lock mechanism will engage.)
6. Perform a self-diagnosis check of all control units using CONSULT-III.

PRECAUTIONS

< PRECAUTION >

Precaution for Procedure without Cowl Top Cover

INFOID:000000001181402

When performing the procedure after removing cowl top cover, cover the lower end of windshield with urethane, etc.

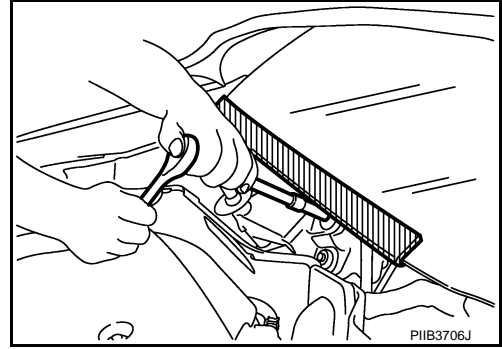

Precautions for Suspension

INFOID:000000001181403

CAUTION:

- When installing rubber bushings, the final tightening must be carried out under unladen conditions with tires on ground. Oil might shorten the life of rubber bushings. Be sure to wipe off any spilled oil.
- Unladen conditions mean that fuel, engine coolant and lubricant are full. Spare tire, jack, hand tools and mats are in designated positions.
- After servicing suspension parts, be sure to check wheel alignment.
- Self-lock nuts are not reusable. Always use new ones when installing. Since new self-lock nuts are pre-oiled, tighten as they are.

PREPARATION

< PREPARATION >

PREPARATION

PREPARATION

Special Service Tool

INFOID:000000001181404

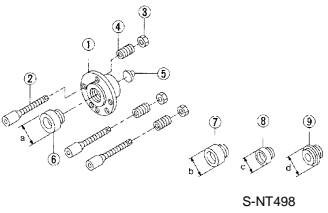
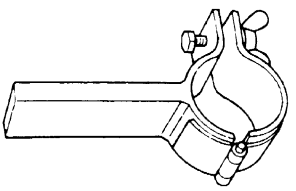
Tool number Tool name	Description
KV991040S0 CCK gauge attachment 1. Plate 2. Guide bolt 3. Nut 4. Spring 5. Center plate 6. KV99104020 Adapter A a: 72 mm (2.83 in) dia. 7. KV99104030 Adapter B b: 65 mm (2.56 in) dia. 8. KV99104040 Adapter C c: 57 mm (2.24 in) dia. 9. KV99104050 Adapter D d: 53.4 mm (2.102 in) dia.	Measuring wheel alignment 
ST35652000 Strut attachment	Disassembling and assembling strut 

Commercial Service Tool

INFOID:000000001181405

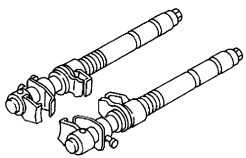
Tool name	Description
Spring compressor	Removing and installing coil spring 

FRONT SUSPENSION ASSEMBLY

< ON-VEHICLE MAINTENANCE >

ON-VEHICLE MAINTENANCE

FRONT SUSPENSION ASSEMBLY

Inspection

INFOID:000000001181406

MOUNTING INSPECTION

Make sure the mounting conditions (looseness, backlash) of each component and component conditions (wear, damage) are normal.

BALL JOINT AXIAL END PLAY

1. Set front wheels in a straight-ahead position.

CAUTION:

Never depress brake pedal.

2. Place an iron bar or equivalent between transverse link and steering knuckle.
3. Measure axial end play by prying it up and down.

Standard

End play : Refer to [FSU-22, "Ball Joint"](#).

CAUTION:

Be careful not to damage ball joint boot. Never damage the installation position by applying excessive force.

STRUT ASSEMBLY

Check for oil leakage and damage, and replace if malfunction is detected.

WHEEL ALIGNMENT

< ON-VEHICLE MAINTENANCE >

WHEEL ALIGNMENT

Wheel Alignment Inspection

INFOID:000000001181407

INSPECTION

Description

CAUTION:

- **Camber, caster, kingpin inclination angles cannot be adjusted.**
- **If camber, caster, or kingpin inclination angle exceeds the standard value, check front suspension parts for wear and damage. Replace suspect parts if a malfunction is detected.**
- **Kingpin inclination angle is reference value, no inspection is required.**

Measure wheel alignment under unladen conditions.

NOTE:

"Unladen conditions" means that fuel, engine coolant, and lubricant are full. Spare tire, jack, hand tools and mats are in designated positions.

Preliminary Check

Check the following:

- Tires for improper air pressure and wear
- Road wheels for runout: Refer to [WT-3, "Adjustment"](#).
- Wheel bearing axial end play: Refer to [FAX-7, "Inspection"](#) (2WD), [FAX-59, "Inspection"](#) (4WD).
- Transverse link ball joint axial end play: Refer to [FSU-6, "Inspection"](#).
- Strut operation.
- Each mounting part of axle and suspension for looseness and deformation
- Each of suspension member and transverse link for cracks, deformation and other damage
- Vehicle height (posture)

CAMBER, CASTER, AND KINGPIN INCLINATION ANGLES

- Camber, caster, kingpin inclination angles cannot be adjusted.
- Before inspection, mount front wheels onto turning radius gauge. Mount rear wheels onto a stand at the same height so that vehicle remains horizontal.

Using a CCK Gauge

Install the CCK gauge attachment (SST: KV991040S0) with the following procedure on wheel, then measure wheel alignment.

1. Remove three wheel to nuts, and install the guide bolts to hub bolt.
2. Screw the adapter into the plate until it contacts the plate tightly.
3. Screw the center plate into the plate.
4. Insert the plate assembly on the guide bolt. Put the spring in, and then evenly screw the three guide bolt nuts. When fastening the guide nuts, do not completely compress the spring.

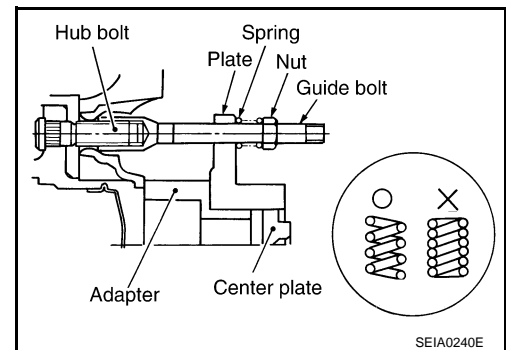

5. Place the dent of alignment gauge onto the projection of the center plate and tightly contact them to measure.

Camber, caster, kingpin inclination angles : Refer to [FSU-22, "Wheel Alignment"](#).

CAUTION:

- **If camber, caster, or kingpin inclination angle exceeds the standard value, check front suspension parts for wear and damage. Replace suspect parts if a malfunction is detected.**
- **Kingpin inclination angle is reference value, no inspection is required.**

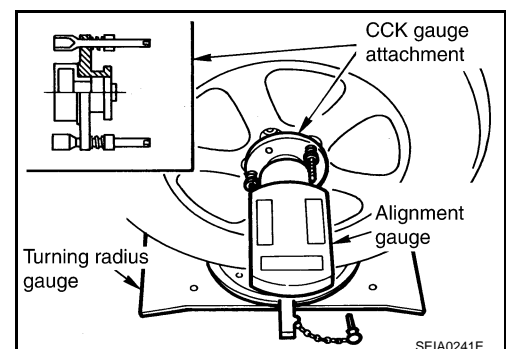

WHEEL ALIGNMENT

< ON-VEHICLE MAINTENANCE >

Toe-In

Measure toe-in by the following procedure.

WARNING:

- Always perform the following procedure on a flat surface.
- Make sure that no person is in front of vehicle before pushing it.

1. Bounce front of vehicle up and down to stabilize the vehicle height (posture).
2. Push vehicle straight ahead about 5 m (16 ft).
3. Put matching mark (A) on base line of the tread (rear side) of both tires at the same height of hub center. These are measuring points.

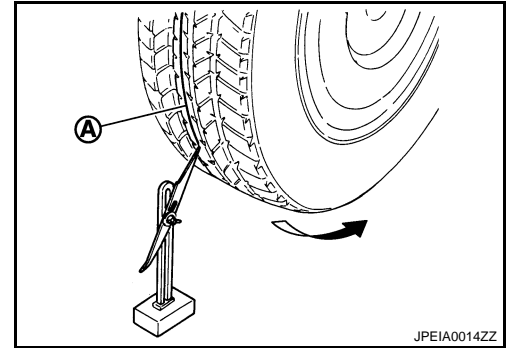

4. Measure distance (A) (rear side).
5. Push vehicle slowly ahead to rotate wheels 180 degrees (1/2 turn).

NOTE:

If the wheels rotate more than 180 degrees (1/2 turn), start this procedure again from the beginning. Do not push the vehicle backward.

6. Measure distance (B) (front side).

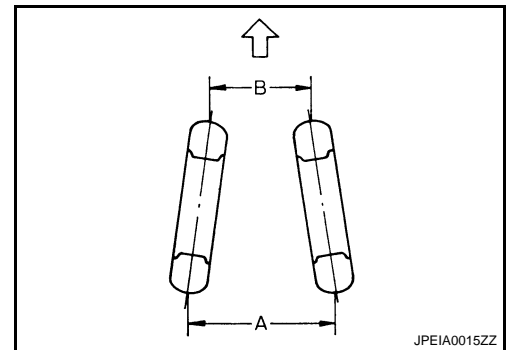

$$\text{Total toe-in} = A - B$$

Total toe-in : Refer to [FSU-22. "Wheel Alignment"](#).

- If toe-in exceeds the standard value, adjust toe-in by varying the length of between steering outer socket and inner socket.

FRONT COIL SPRING AND STRUT

< ON-VEHICLE REPAIR >

ON-VEHICLE REPAIR

FRONT COIL SPRING AND STRUT

Exploded View

INFOID:000000001538047

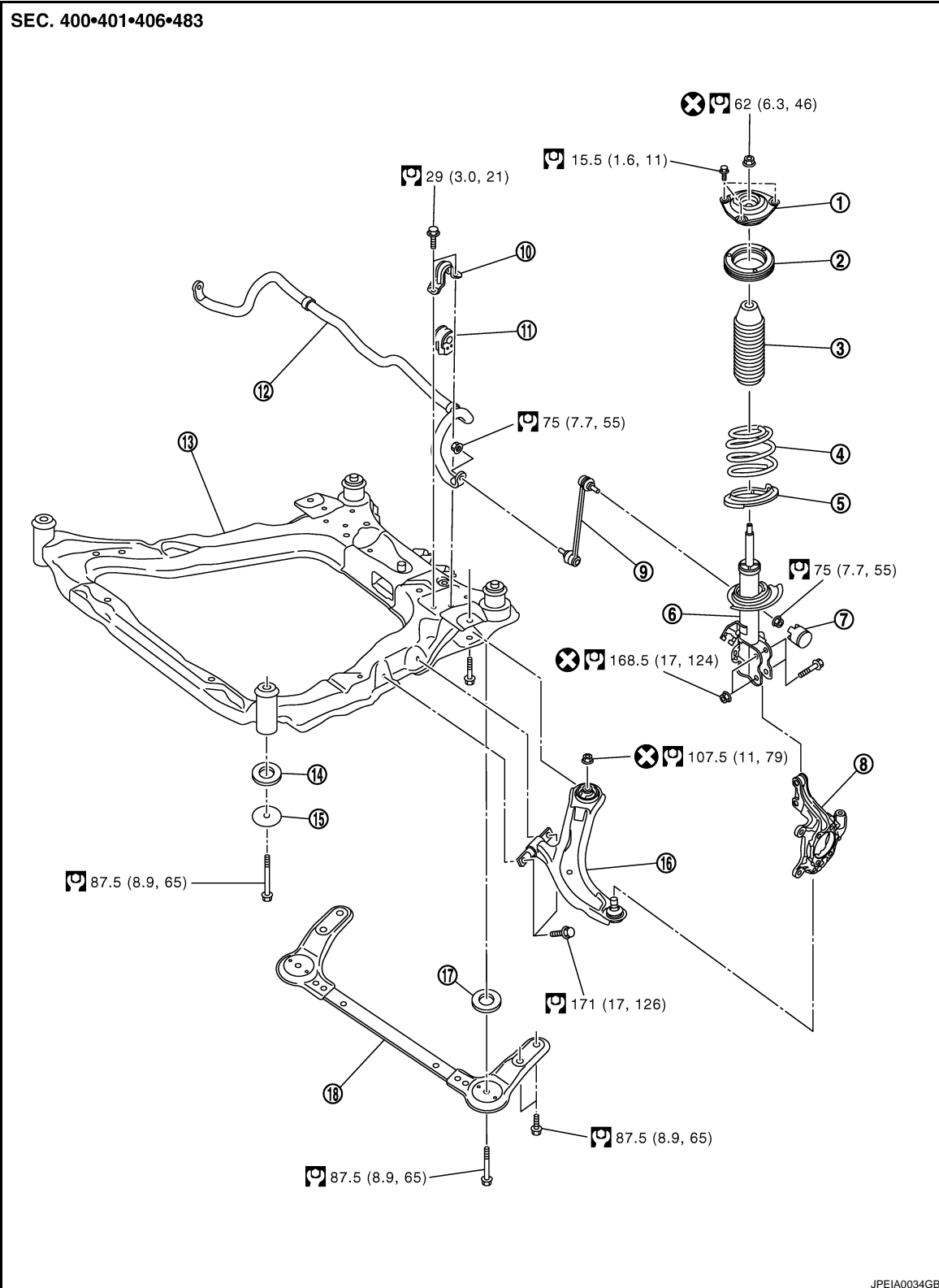

JPEIA0034GB

A
B
C
D
F
G
H
I
J
K
L
M
N
O
P

FSU

FRONT COIL SPRING AND STRUT

< ON-VEHICLE REPAIR >

- | | | |
|-----------------------------|-----------------------------|----------------------------------|
| 1. Strut mounting insulator | 2. Strut mounting bearing | 3. Bound bumper |
| 4. Coil spring | 5. Lower rubber seat | 6. Strut |
| 7. Cap | 8. Steering knuckle | 9. Stabilizer connecting rod |
| 10. Stabilizer clamp | 11. Stabilizer bushing | 12. Stabilizer bar |
| 13. Front suspension member | 14. Rebound stopper rubber* | 15. Rebound stopper insulator |
| 16. Transverse link | 17. Rebound stopper | 18. Front suspension member stay |

*: If equipped.

Refer to [GI-4, "Components"](#) for symbols in the figure.

Removal and Installation

INFOID:000000001181409

REMOVAL

1. Remove tires from vehicle.
2. Remove lock plat. [BR-19, "FRONT \(WITHOUT ESP\) : Exploded View"](#) (LHD without ESP), [BR-22, "FRONT \(WITH ESP\) : Exploded View"](#) (LHD with ESP), [BR-66, "FRONT \(WITHOUT ESP\) : Exploded View"](#) (RHD without ESP), [BR-69, "FRONT \(WITH ESP\) : Exploded View"](#) (RHD with ESP).
3. Remove cap and mounting nut on the upper side of stabilizer connecting rod, and then remove stabilizer connecting rod from strut assembly.
4. Separate steering knuckle from strut assembly.
5. Remove mounting bolts of strut mounting insulator, and then remove strut assembly.

INSTALLATION

Note the following, and install in the reverse order of removal.

- Make sure the identification mark (A) on strut mounting insulator as shown in the figure.

⇐ : Vehicle front

- Perform final tightening of bolts and nuts, under unladen conditions with tires on level ground.

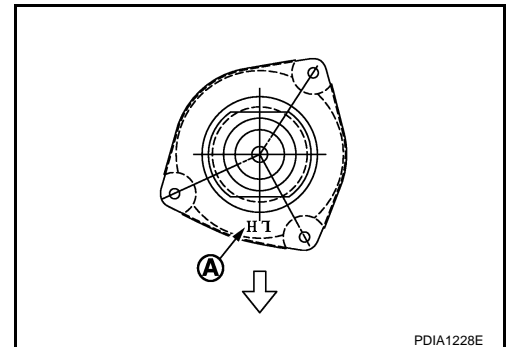

Disassembly and Assembly

INFOID:000000001181410

DISASSEMBLY

CAUTION:

Never damage strut assembly piston rod when removing components from strut assembly.

1. Install strut attachment (A) (SST: ST35652000) to strut assembly and secure it in a vise.

CAUTION:

When installing the strut attachment to strut assembly, wrap a shop cloth around strut to protect from damage.

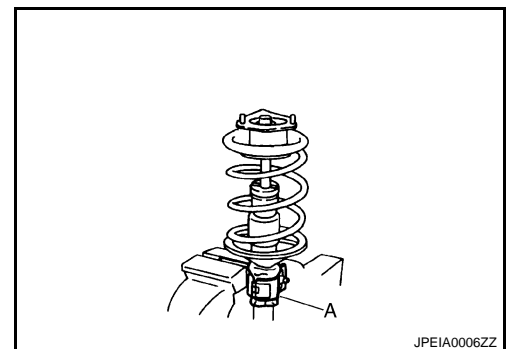

FRONT COIL SPRING AND STRUT

< ON-VEHICLE REPAIR >

- Using a spring compressor (A) (commercial service tool), compress coil spring between strut mounting bearing and lower rubber seat (on strut assembly) until coil spring with a spring compressor is free.

CAUTION:

Be sure a spring compressor is securely attached to coil spring. Compress coil spring.

- Make sure coil spring with a spring compressor between strut mounting bearing and lower rubber seat (strut assembly) is free. And then remove piston rod lock nut while securing the piston rod tip so that piston rod does not turn.

- Remove strut mounting insulator and strut mounting bearing, and bound bumper from strut.

- After remove coil spring with a spring compressor, and then gradually release a spring compressor.

CAUTION:

Loosen while making sure coil spring attachment position does not move.

- Remove lower rubber seat from strut.
- Remove the strut attachment (SST: ST35652000) from strut.

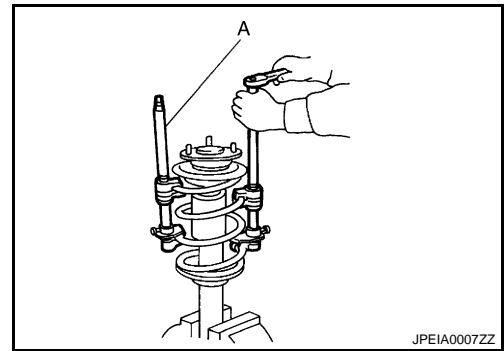

A
B
C
D

FSU

ASSEMBLY

- Install strut attachment (SST: ST35652000) to strut and secure it in a vise.

CAUTION:

When installing the strut attachment to strut assembly, wrap a shop cloth around strut to protect from damage.

- Install lower rubber seat.
- Install bound bumper.
- Compress coil spring using a spring compressor (commercial service tool), and install it onto strut assembly.

CAUTION:

- Face tube side of coil spring (1) downward. Align the lower end (A) to lower rubber seat (2).
- Be sure a spring compress is securely attached to coil spring. Compress coil spring.

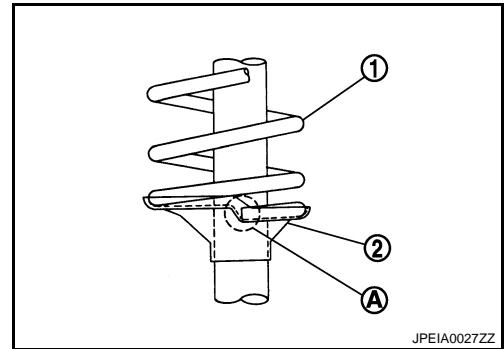

F
G
H
I
J
K
L
M

- Install strut mounting bearing and strut mounting insulator to strut.
 - Installation position of strut mounting insulator as shown in the figure.

A : Identification mark

⇐ : Vehicle front

- Secure piston rod tip so that piston rod does not turn, then tighten piston rod lock nut with specified torque.

CAUTION:

Never reuse piston rod lock nut.

- Gradually release a spring compressor, and remove coil spring.

CAUTION:

Loosen while making sure coil spring attachment position does not move.

- Remove the strut attachment from strut assembly.

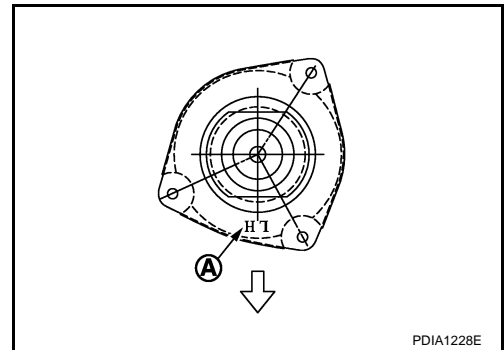

N
O
P

FRONT COIL SPRING AND STRUT

< ON-VEHICLE REPAIR >

Inspection

INFOID:000000001181411

INSPECTION AFTER INSTALLATION

1. Check wheel alignment. Refer to [FSU-7, "Wheel Alignment Inspection"](#).
2. Adjust neutral position of steering angle sensor. Refer to [BRC-77, "ADJUSTMENT OF STEERING ANGLE SENSOR NEUTRAL POSITION : Special Repair Requirement"](#) (with ESP).

INSPECTION AFTER DISASSEMBLY

Strut

Check the following items, and replace the parts if necessary.

- Strut for deformation, cracks or damage
- Piston rod for damage, uneven wear or distortion
- For oil leakage

Strut Mounting Insulator and Rubber Parts Inspection

Check strut mounting insulator for cracks and rubber parts for wear. Replace it if necessary.

Coil Spring

Check coil spring for cracks, wear or damage. Replace it if necessary.

TRANSVERSE LINK

< ON-VEHICLE REPAIR >
TRANSVERSE LINK

Exploded View

INFOID:000000001538048

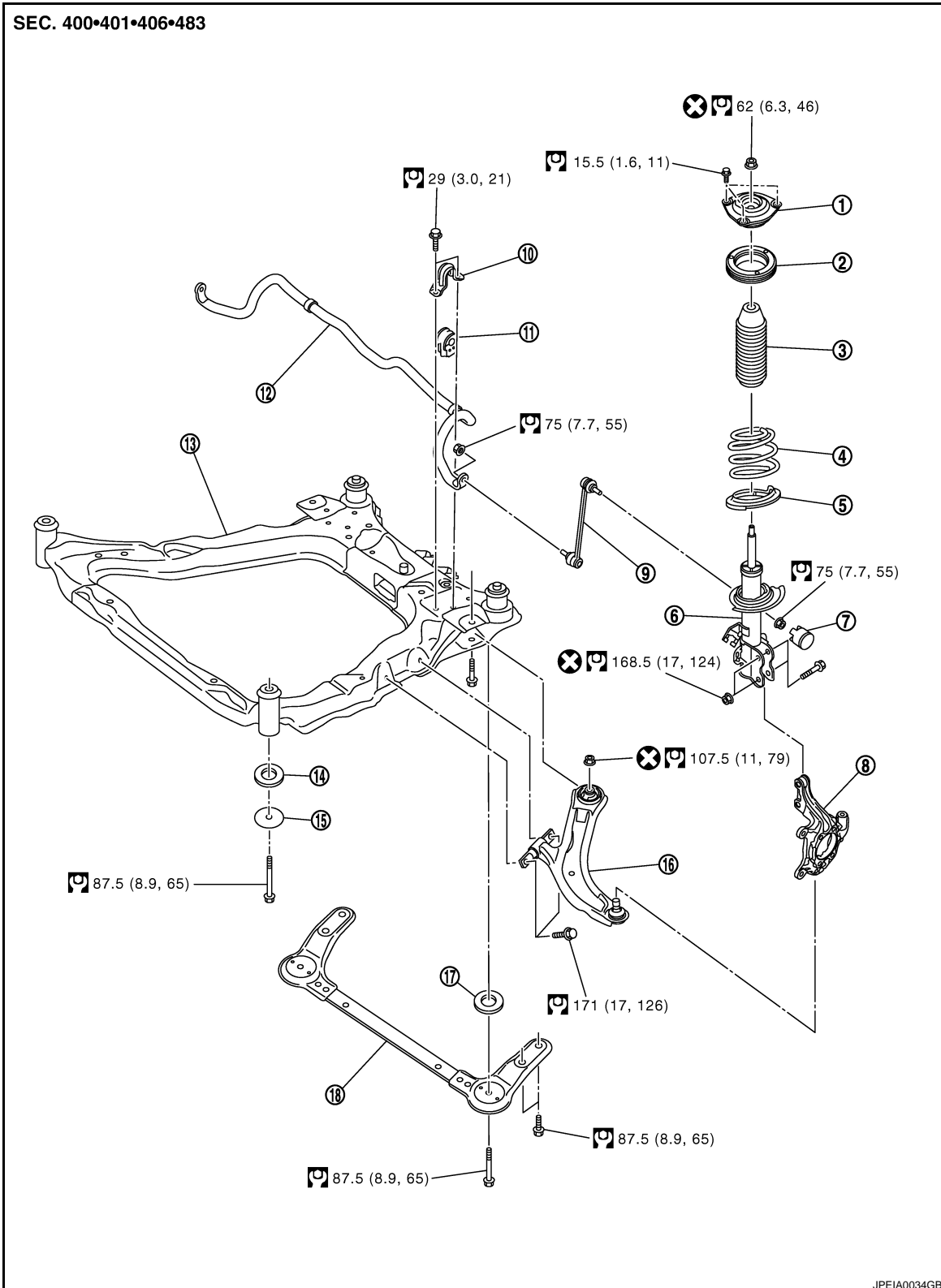

- | | | |
|-----------------------------|---------------------------|------------------------------|
| 1. Strut mounting insulator | 2. Strut mounting bearing | 3. Bound bumper |
| 4. Coil spring | 5. Lower rubber seat | 6. Strut |
| 7. Cap | 8. Steering knuckle | 9. Stabilizer connecting rod |

FSU-13

A
 B
 C
 D
FSU
 F
 G
 H
 I
 J
 K
 L
 M
 N
 O
 P

JPEIA0034GB

TRANSVERSE LINK

< ON-VEHICLE REPAIR >

- | | | |
|-----------------------------|-----------------------------|----------------------------------|
| 10. Stabilizer clamp | 11. Stabilizer bushing | 12. Stabilizer bar |
| 13. Front suspension member | 14. Rebound stopper rubber* | 15. Rebound stopper insulator |
| 16. Transverse link | 17. Rebound stopper | 18. Front suspension member stay |

*: If equipped.

Refer to [GI-4. "Components"](#) for symbols in the figure.

Removal and Installation

INFOID:000000001181413

REMOVAL

1. Remove tires from vehicle.
2. Remove transverse link from steering knuckle.
3. Remove transverse link from suspension member.

NOTE:

Transverse link cannot be pulled out because the mounting bolt (←) of transverse link at the rear of the mounting area located on the front side of vehicle hits against the stabilizer bar. Therefore, get stabilizer bar out of the way to remove the transverse link.

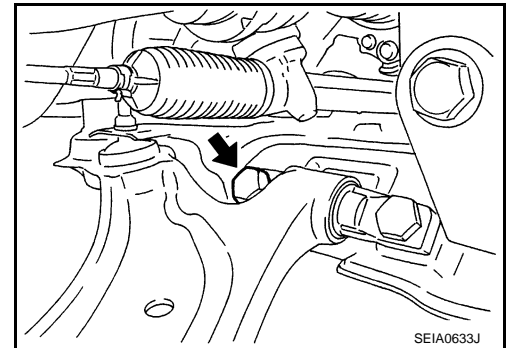

INSTALLATION

Note the following, and install in the reverse order of removal.

- Perform final tightening of bolts and nuts at the front suspension member, under unladen conditions with tires on level ground.

Inspection

INFOID:000000001181414

INSPECTION AFTER REMOVAL

Visual Inspection

Check the following:

- Transverse link and bushing for deformation, cracks or damage. Replace it if necessary.
- Ball joint boot for cracks or other damage, and also for grease leakage. Replace it if necessary.

Ball Joint Inspection

Manually move ball stud to confirm it moves smoothly with no binding.

Swing Torque Inspection

NOTE:

Before measurement, move ball stud at least ten times by hand to check for smooth movement.

- Hook a spring balance (A) at cotter pin mounting hole. Confirm spring balance measurement value is within specifications when ball stud begins moving.

Standard

Swing torque :Refer to [FSU-22. "Ball Joint"](#).

Spring balance measurement :Refer to [FSU-22. "Ball Joint"](#).

- If swing torque exceeds standard range, replace transverse link assembly.

Axial End Play Inspection

- Move tip of ball stud in axial direction to check for looseness.

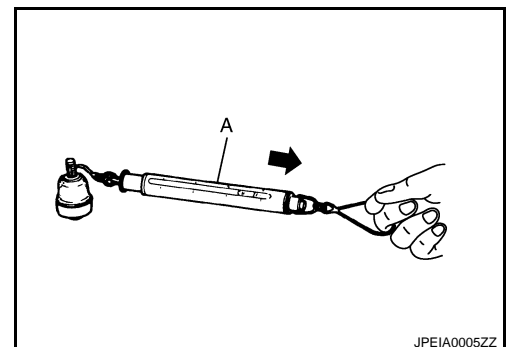

TRANSVERSE LINK

< ON-VEHICLE REPAIR >

Standard

Axial end play :Refer to [FSU-22, "Ball Joint"](#).

- If axial end play exceeds the standard value, replace transverse link assembly.

INSPECTION AFTER INSTALLATION

1. Check wheel alignment. Refer to [FSU-7, "Wheel Alignment Inspection"](#).
2. Adjust neutral position of steering angle sensor. Refer to [BRC-77, "ADJUSTMENT OF STEERING ANGLE SENSOR NEUTRAL POSITION : Special Repair Requirement"](#) (with ESP).

A

B

C

D

FSU

F

G

H

I

J

K

L

M

N

O

P

FRONT STABILIZER

< ON-VEHICLE REPAIR >
FRONT STABILIZER

Exploded View

INFOID:000000001538049

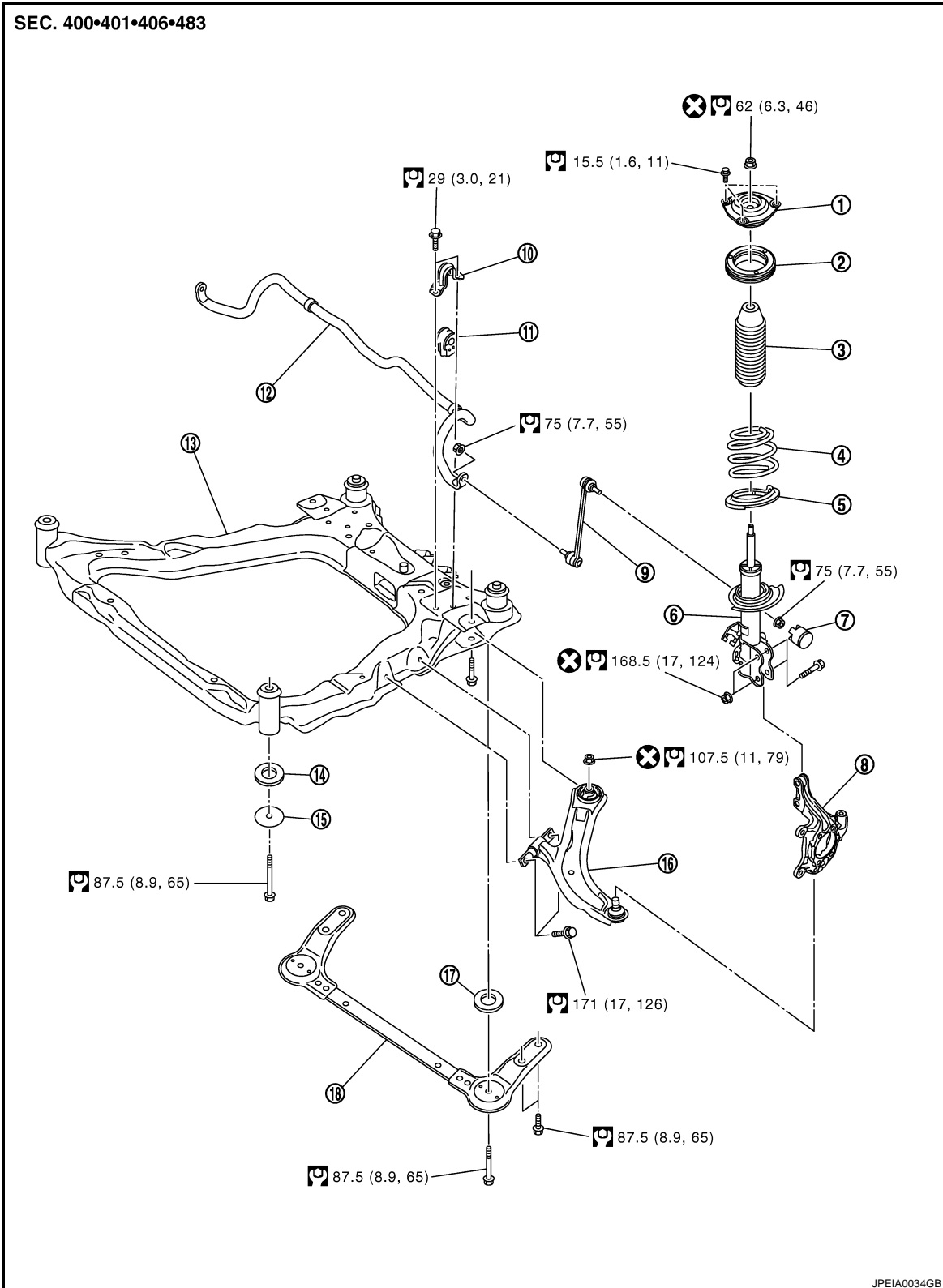

- | | | |
|-----------------------------|---------------------------|------------------------------|
| 1. Strut mounting insulator | 2. Strut mounting bearing | 3. Bound bumper |
| 4. Coil spring | 5. Lower rubber seat | 6. Strut |
| 7. Cap | 8. Steering knuckle | 9. Stabilizer connecting rod |

FSU-16

FRONT STABILIZER

< ON-VEHICLE REPAIR >

- | | | |
|-----------------------------|-----------------------------|----------------------------------|
| 10. Stabilizer clamp | 11. Stabilizer bushing | 12. Stabilizer bar |
| 13. Front suspension member | 14. Rebound stopper rubber* | 15. Rebound stopper insulator |
| 16. Transverse link | 17. Rebound stopper | 18. Front suspension member stay |
- *: If equipped.

Refer to [GI-4. "Components"](#) for symbols in the figure.

Removal and Installation

INFOID:000000001181416

REMOVAL

1. Remove tires from vehicle.
2. Remove steering outer socket from steering knuckle. Refer to [ST-13. "Exploded View"](#).
3. Remove stabilizer connecting rod. Refer to [FSU-20. "Exploded View"](#).
4. Remove under cover from vehicle.
5. Remove front suspension member stay from vehicle. Refer to [FSU-20. "Exploded View"](#).
6. Remove rear torque rod. Refer to [EM-84. "Exploded View"](#) (HR16DE), [EM-195. "M/T : Exploded View"](#) (MR20DE M/T models), [EM-200. "CVT : Exploded View"](#) (MR20DE CVT models), [EM-299. "Exploded View"](#) (K9K), [EM-403. "Exploded View"](#) (M9R).
7. Separate intermediate shaft from steering gear. Refer to [ST-10. "Exploded View"](#).
8. Set suitable jack front suspension member.
9. Gradually lower jack front suspension member in order to remove stabilizer mounting bolts.

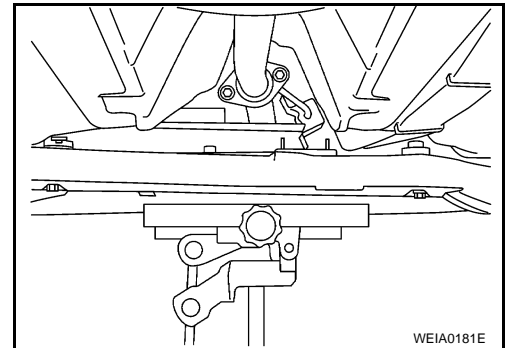

10. Remove mounting bolts (←) of stabilizer clamp, and then remove stabilizer clamp and stabilizer bushing from front suspension member.
11. Remove stabilizer bar.

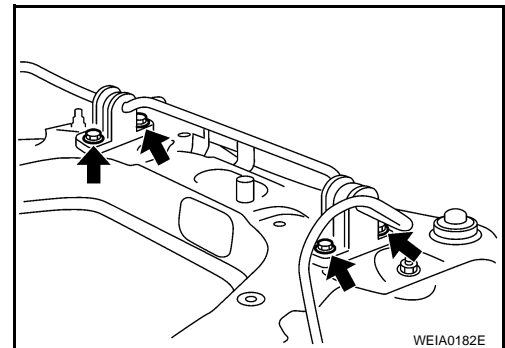

INSTALLATION

Install in the reverse order of removal.

Inspection

INFOID:000000001181417

INSPECTION AFTER REMOVAL

Check stabilizer bar, stabilizer connecting rod, stabilizer bushing and stabilizer clamp for deformation, cracks or damage. Replace it if necessary.

FRONT SUSPENSION MEMBER

< ON-VEHICLE REPAIR >

FRONT SUSPENSION MEMBER

Exploded View

INFOID:000000001538050

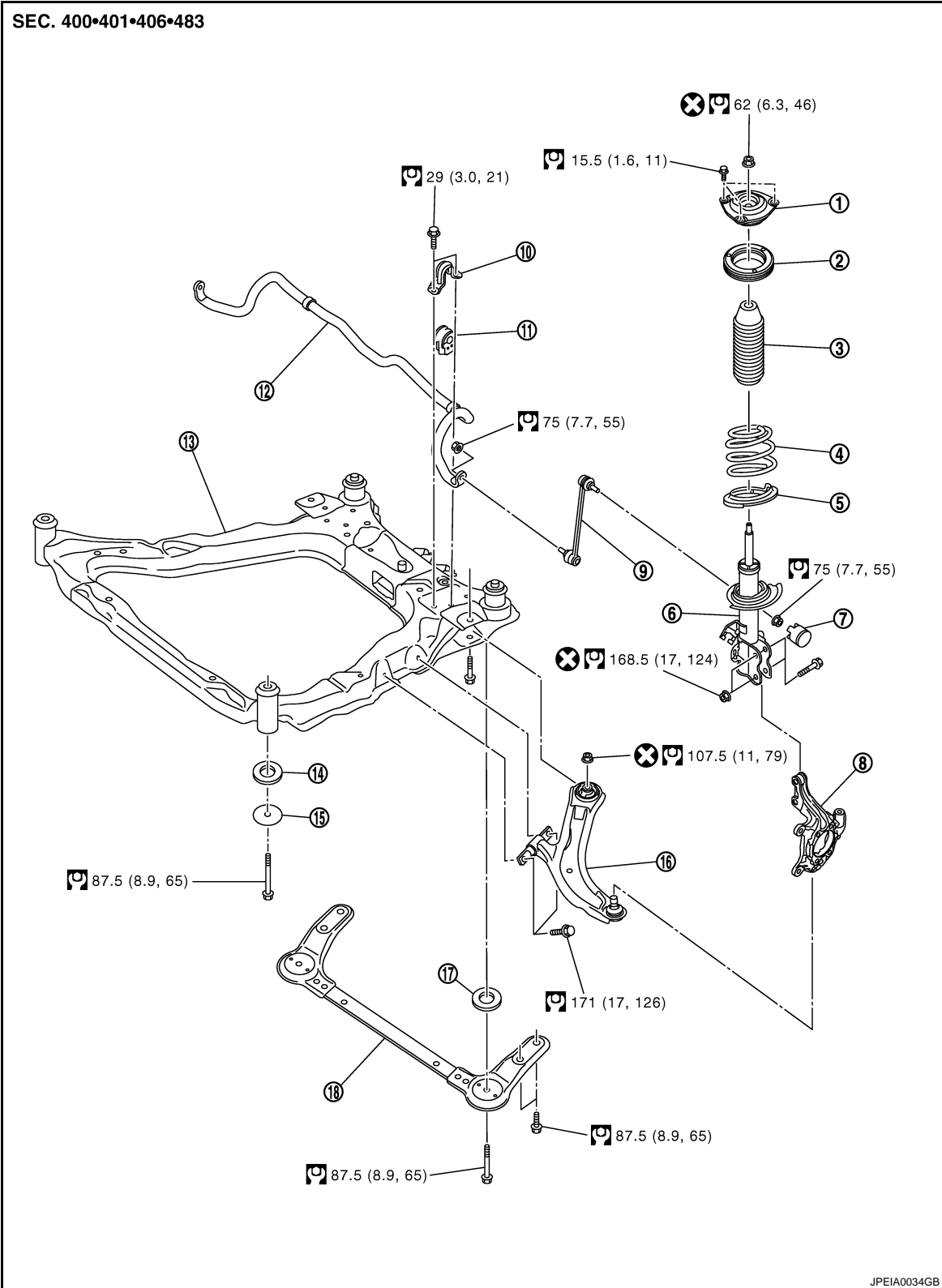

- | | | |
|-----------------------------|---------------------------|------------------------------|
| 1. Strut mounting insulator | 2. Strut mounting bearing | 3. Bound bumper |
| 4. Coil spring | 5. Lower rubber seat | 6. Strut |
| 7. Cap | 8. Steering knuckle | 9. Stabilizer connecting rod |

FSU-18

FRONT SUSPENSION MEMBER

< ON-VEHICLE REPAIR >

- | | | |
|-----------------------------|-----------------------------|----------------------------------|
| 10. Stabilizer clamp | 11. Stabilizer bushing | 12. Stabilizer bar |
| 13. Front suspension member | 14. Rebound stopper rubber* | 15. Rebound stopper insulator |
| 16. Transverse link | 17. Rebound stopper | 18. Front suspension member stay |

*: If equipped.

Refer to [GI-4. "Components"](#) for symbols in the figure.

Removal and Installation

INFOID:000000001181419

REMOVAL

1. Remove tires from vehicle.
2. Remove under cover from vehicle.
3. Remove front suspension member stay from vehicle. Refer to [FSU-20. "Exploded View"](#).
4. Remove wheel sensor from steering knuckle. Refer to [BRC-66. "FRONT WHEEL SENSOR : Exploded View"](#) (without ESP), [BRC-171. "FRONT WHEEL SENSOR : Exploded View"](#) (with ESP).
5. Remove upper side of stabilizer connecting rod from strut assembly. Refer to [FSU-20. "Exploded View"](#).
6. Remove steering outer socket from steering knuckle. Refer to [ST-13. "Exploded View"](#).
7. Separate intermediate shaft from steering gear. Refer to [ST-10. "Exploded View"](#).
8. Remove transverse link from steering knuckle. Refer to [FSU-13. "Exploded View"](#).
9. Remove rear torque rod. Refer to [EM-84. "Exploded View"](#) (HR16DE), [EM-195. "M/T : Exploded View"](#) (MR20DE M/T models), [EM-200. "CVT : Exploded View"](#) (MR20DE CVT models), [EM-299. "Exploded View"](#) (K9K), [EM-403. "Exploded View"](#) (M9R).
10. Set suitable jack front suspension member.
11. Remove mounting bolts and nuts of front suspension member.
12. Gradually lower jack to remove front suspension assembly from vehicle.
CAUTION:
Secure suspension assembly to suitable jack while removing it.
13. Remove mounting bolts and nuts, and then remove transverse link, stabilizer bar from front suspension member.

INSTALLATION

Note the following, and install in the reverse order of removal.

- Perform final tightening of installation position between front suspension member and transverse links (rubber bushing) under unladen condition with tires on level ground.

Inspection

INFOID:000000001181420

INSPECTION AFTER REMOVAL

Check the front suspension member for significant deformation, cracks, or damages. Replace it if necessary.

INSPECTION AFTER INSTALLATION

1. Check wheel alignment. Refer to [FSU-7. "Wheel Alignment Inspection"](#).
2. Adjust the neutral position of the steering angle sensor. Refer to [BRC-77. "ADJUSTMENT OF STEERING ANGLE SENSOR NEUTRAL POSITION : Special Repair Requirement"](#) (with ESP).

FRONT SUSPENSION ASSEMBLY

< REMOVAL AND INSTALLATION >

REMOVAL AND INSTALLATION

FRONT SUSPENSION ASSEMBLY

Exploded View

INFOID:000000001181421

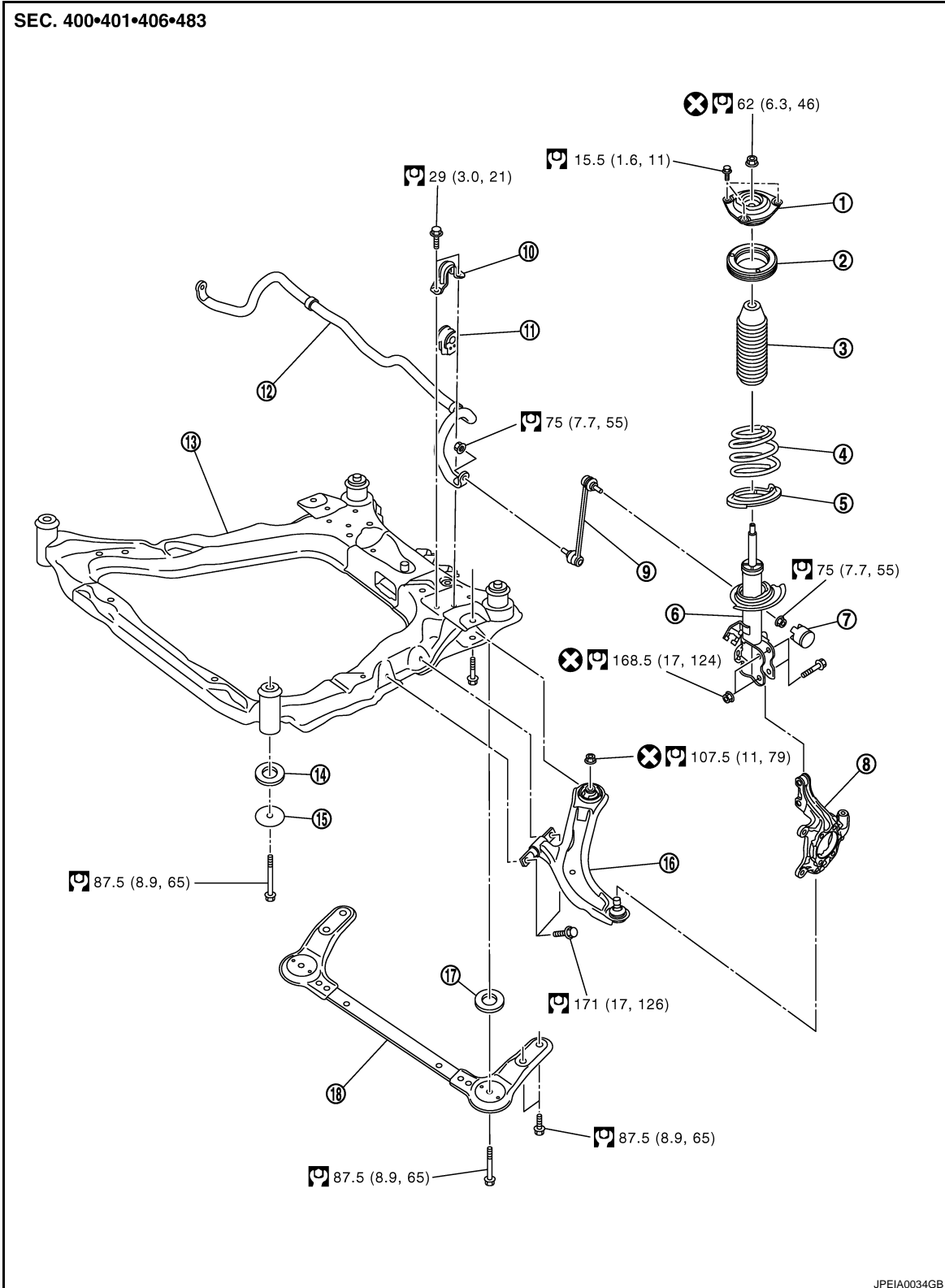

JPEIA0034GB

FRONT SUSPENSION ASSEMBLY

< REMOVAL AND INSTALLATION >

- | | | | |
|-----------------------------|-----------------------------|----------------------------------|---|
| 1. Strut mounting insulator | 2. Strut mounting bearing | 3. Bound bumper | A |
| 4. Coil spring | 5. Lower rubber seat | 6. Strut | |
| 7. Cap | 8. Steering knuckle | 9. Stabilizer connecting rod | |
| 10. Stabilizer clamp | 11. Stabilizer bushing | 12. Stabilizer bar | B |
| 13. Front suspension member | 14. Rebound stopper rubber* | 15. Rebound stopper insulator | |
| 16. Transverse link | 17. Rebound stopper | 18. Front suspension member stay | C |

*: If equipped.

Refer to [GI-4, "Components"](#) for symbols in the figure.

Removal and Installation

INFOID:000000001181422

REMOVAL

Refer to the procedure from 1 to 13 in [FSU-19, "Removal and Installation"](#).

INSTALLATION

Note the following, and install in the reverse order of removal.

- Perform final tightening of bolts and nuts at the vehicle installation position (rubber bushing), under unladen conditions with tires on level ground.

Inspection

INFOID:000000001181423

INSPECTION AFTER REMOVAL

Check the front suspension member for significant deformation, cracks, or damages. Replace it if necessary.

INSPECTION AFTER INSTALLATION

1. Check wheel alignment. Refer to [FSU-7, "Wheel Alignment Inspection"](#).
2. Adjust the neutral position of the steering angle sensor. Refer to [BRC-77, "ADJUSTMENT OF STEERING ANGLE SENSOR NEUTRAL POSITION : Special Repair Requirement"](#) (with ESP).

FSU

F

G

H

I

J

K

L

M

N

O

P

SERVICE DATA AND SPECIFICATIONS (SDS)

< SERVICE DATA AND SPECIFICATIONS (SDS)

SERVICE DATA AND SPECIFICATIONS (SDS)

SERVICE DATA AND SPECIFICATIONS (SDS)

Wheel Alignment

INFOID:000000001181424

Tire size		215/65R16	215/60R17	
Camber Degree minute (Decimal degree)	Minimum	-1° 10' (-1.17°)		
	Nominal	-0° 25' (-0.42°)		
	Maximum	0° 20' (0.33°)		
	Left and right difference	0° 33' (0.55°) or less		
Caster Degree minute (Decimal degree)	Minimum	3° 55' (3.92°)	4° 00' (4.00°)	
	Nominal	4° 40' (4.67°)	4° 45' (4.75°)	
	Maximum	5° 25' (5.42°)	5° 30' (5.50°)	
	Left and right difference	0° 45' (0.75°) or less		
Kingpin inclination Degree minute (Decimal degree)	Minimum	9° 40' (6.67°)		
	Nominal	10° 25' (10.42°)		
	Maximum	11° 10' (11.17°)		
Total toe-in	Distance	Minimum	In 1 mm (0.04 in)	
		Nominal	In 2 mm (0.08 in)	
		Maximum	In 3 mm (0.12 in)	
	Angle (left wheel or right wheel) Degree minute (Decimal degree)	Minimum	In 0° 02' 30" (0.04°)	
		Nominal	In 0° 05' (0.08°)	
		Maximum	In 0° 07' 30" (0.13°)	

Measure value under unladen* conditions.

*: Fuel, engine coolant and lubricant are full. Spare tire, jack, hand tools and mats are in designated positions.

Ball Joint

INFOID:000000001181425

Swing torque	Transverse link	0.5 – 3.4 N·m (0.06 – 0.34 kg·m, 5 – 30 in·lb)
Measurement on spring balance	Transverse link	13.5 – 91.9 N (1.4 – 9.4 kg, 3 – 21 lb)
Axial end play		0 mm (0 in)

Wheel Height

INFOID:000000001181426

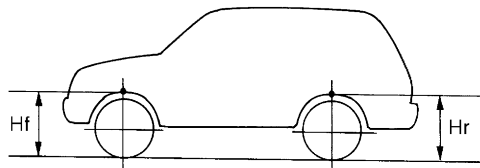

SFA746B

Applied model	Except for M9R	M9R
---------------	----------------	-----

SERVICE DATA AND SPECIFICATIONS (SDS)

< SERVICE DATA AND SPECIFICATIONS (SDS)

Tire size	215/65R16	215/60R17	215/65R16	215/60R17
Front (Hf)	762 mm (30.00 in)	765 mm (30.12 in)	756 mm (29.76 in)	758 mm (29.84 in)

Measure value under unladen* conditions.

*: Fuel, engine coolant and lubricant are full. Spare tire, jack, hand tools and mats are in designated positions.

A
B
C
D
F
G
H
I
J
K
L
M
N
O
P

FSU