

SECTION **GI**
GENERAL INFORMATION

B
C
D
E
F
G
H
I
J
K
L
M
N
O
P

CONTENTS

HOW TO USE THIS MANUAL	3	PRECAUTIONS	27
HOW TO USE THIS MANUAL	3	Description	27
Description	3	Precaution for Supplemental Restraint System (SRS) "AIR BAG" and "SEAT BELT PRE-TENSIONER"	27
Terms	3	Precautions For Xenon Headlamp Service	27
Units	3	Precaution Necessary for Steering Wheel Rotation After Battery Disconnect	27
Contents	3	Precaution for Procedure without Cowl Top Cover...28	
Relation between Illustrations and Descriptions	4	General Precautions	28
Components	4	Three Way Catalyst	30
HOW TO FOLLOW TROUBLE DIAGNOSES	6	Multiport Fuel Injection System or Engine Control System	30
Description	6	Turbocharger (If Equipped)	30
How to Follow Test Groups in Trouble Diagnosis.....	6	Hoses	30
Key to Symbols Signifying Measurements or Procedures	7	Engine Oils	31
HOW TO READ WIRING DIAGRAMS	9	Air Conditioning	32
Connector symbols	9	FUEL	32
Sample/wiring diagram -example-	10	FUEL : Unleaded Premium Gasoline	32
Description	11	FUEL : Diesel Engine Fuel	32
ABBREVIATIONS	13	LIFTING POINT	33
Abbreviation List	13	Commercial Service Tools	33
TIGHTENING TORQUE OF STANDARD BOLTS	14	Garage Jack and Safety Stand and 2-Pole Lift	33
Description	14	Board-On Lift	34
Tightening Torque Table (New Standard Included)	14	TOW TRUCK TOWING	35
TERMINOLOGY	17	Tow Truck Towing	35
SAE J1930 Terminology List	17	Vehicle Recovery (Freeing a Stuck Vehicle)	36
FEATURES OF NEW MODEL	21	BASIC INSPECTION	38
IDENTIFICATION INFORMATION	21	SERVICE INFORMATION FOR ELECTRICAL INCIDENT	38
Model Variation	21	Work Flow	38
Information About Identification or Model Code	22	Control Units and Electrical Parts	38
Dimensions	26	Intermittent Incident	39
Wheels&Tires	26	Circuit Inspection	41
PRECAUTION	27	CONSULT-III/GST CHECKING SYSTEM	47
		Description	47

CONSULT-III Function and System Application*2..	47	Wiring Diagram - CONSULT-III/GST CHECKING	
CONSULT-III/GST Data Link Connector (DLC)		SYSTEM -	49
Circuit	48		

HOW TO USE THIS MANUAL

< HOW TO USE THIS MANUAL >

HOW TO USE THIS MANUAL

HOW TO USE THIS MANUAL

GI

Description

INFOID:000000001178862

This volume explains “Removal, Disassembly, Installation, Inspection and Adjustment” and “Trouble Diagnoses”.

Terms

INFOID:000000001178863

- The captions **WARNING** and **CAUTION** warn you of steps that must be followed to prevent personal injury and/or damage to some part of the vehicle.

WARNING indicates the possibility of personal injury if instructions are not followed.

CAUTION indicates the possibility of component damage if instructions are not followed.

BOLD TYPED STATEMENTS except **WARNING** and **CAUTION** give you helpful information.

Standard value: Tolerance at inspection and adjustment.

Limit value: The maximum or minimum limit value that should not be exceeded at inspection and adjustment.

Units

INFOID:000000001178864

- The **UNITS** given in this manual are primarily expressed as the SI UNIT (International System of Unit), and alternatively expressed in the metric system and in the yard/pound system. Also with regard to tightening torque of bolts and nuts, there are descriptions both about range and about the standard tightening torque.

“Example”

Range

Outer Socket Lock Nut : 59 - 78 N-m (6.0 - 8.0 kg-m, 43 - 58 ft-lb)

Standard

Drive Shaft Installation Bolt : 44.3 N-m (4.5 kg-m, 33 ft-lb)

Contents

INFOID:000000001178865

- **ALPHABETICAL INDEX** is provided at the end of this manual so that you can rapidly find the item and page you are searching for.
- **A QUICK REFERENCE INDEX**, a black tab (e.g. **BR**) is provided on the first page. You can quickly find the first page of each section by matching it to the section's black tab.
- **THE CONTENTS** are listed on the first page of each section.
- **THE TITLE** is indicated on the upper portion of each page and shows the part or system.
- **THE PAGE NUMBER** of each section consists of two or three letters which designate the particular section and a number (e.g. “BR-5”).
- **THE SMALL ILLUSTRATIONS** show the important steps such as inspection, use of special tools, knacks of work and hidden or tricky steps which are not shown in the previous large illustrations. Assembly, inspection and adjustment procedures for the complicated units such as the automatic transaxle or transmission, etc. are presented in a step-by-step format where necessary.

HOW TO USE THIS MANUAL

< HOW TO USE THIS MANUAL >

Relation between Illustrations and Descriptions

INFOID:000000001178866

The following sample explains the relationship between the part description in an illustration, the part name in the text and the service procedures.

< Example 1 >

1. Remove return spring (1) from parking pawl (2).

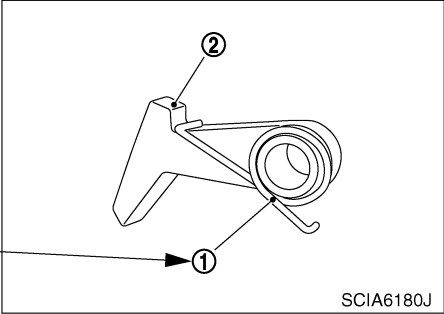

The identifier number of the part name in the text is consistent with the identifier part number in the illustration.

SCIA6180J

Direction mark

< Example 2 >

-  : Vehicle front
- Tighten rear member mounting bolts following the numerical order shown in the illustration.
- Note : View upward

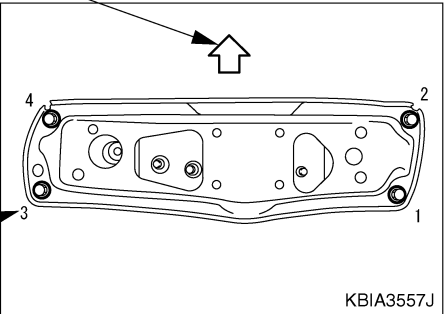

The numbers in the illustration are consistent with the service operation instructions.

KBIA3557J

SAIA0519E

Components

INFOID:000000001178867

- **THE LARGE ILLUSTRATIONS** are exploded views (see the following) and contain tightening torques, lubrication points, section number of the **PARTS CATALOG** (e.g. SEC. 440) and other information necessary to perform repairs.

The illustrations should be used in reference to service matters only. When ordering parts, refer to the appropriate **PARTS CATALOG**.

Components shown in an illustration may be identified by a circled number. When this style of illustration is used, the text description of the components will follow the illustration.

HOW TO USE THIS MANUAL

< HOW TO USE THIS MANUAL >

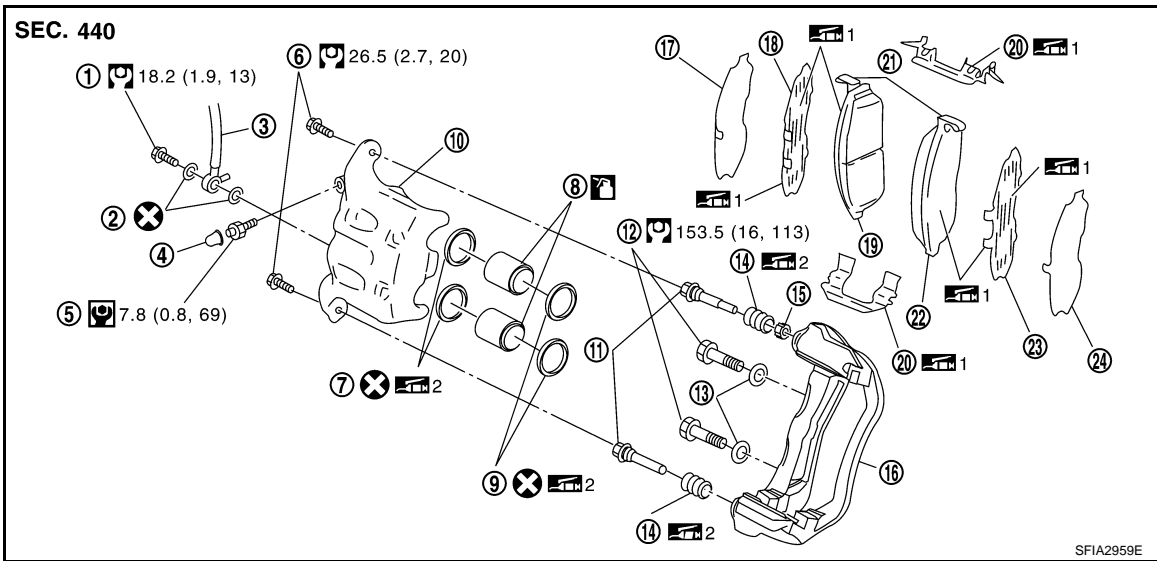

- | | | |
|-------------------|----------------------|---------------------------------|
| 1. Union bolt | 2. Copper washer | 3. Brake hose |
| 4. Cap | 5. Bleed valve | 6. Sliding pin bolt |
| 7. Piston seal | 8. Piston | 9. Piston boot |
| 10. Cylinder body | 11. Sliding pin | 12. Torque member mounting bolt |
| 13. Washer | 14. Sliding pin boot | 15. Bushing |
| 16. Torque member | 17. Inner shim cover | 18. Inner shim |
| 19. Inner pad | 20. Pad retainer | 21. Pad wear sensor |
| 22. Outer pad | 23. Outer shim | 24. Outer shim cover |
- 1: PBC (Poly Butyl Cuprysil) grease
 2: Rubber grease or silicone-based grease
 : Brake fluid

Refer to GI section for additional symbol definitions.

SYMBOLS

SYMBOL	DESCRIPTION	SYMBOL	DESCRIPTION	
	Tightening torque The tightening torque specifications of bolts and nuts may be presented as either a range or a standard tightening torque.	: N•m (kg-m, ft-lb)		Always replace after every disassembly.
		: N•m (kg-m, in-lb)		Apply petroleum jelly.
	Should be lubricated with grease. Unless otherwise indicated, use recommended multi-purpose grease.			Apply molybdenum added petroleum jelly.
	Should be lubricated with oil.			Apply ATF.
	Sealing point		★	Select with proper thickness.
	Sealing point with locking sealant.		☆	Adjustment is required.
	Checking point			

SAIA0749E

HOW TO FOLLOW TROUBLE DIAGNOSES

< HOW TO USE THIS MANUAL >

HOW TO FOLLOW TROUBLE DIAGNOSES

Description

INFOID:000000001178868

NOTICE:

Trouble diagnoses indicate work procedures required to diagnose problems effectively. Observe the following instructions before diagnosing.

- Before performing trouble diagnoses, read the “Work Flow” in each section.
- After repairs, re-check that the problem has been completely eliminated.
- Refer to Component Parts and Harness Connector Location for the Systems described in each section for identification/location of components and harness connectors.
- When checking circuit continuity, ignition switch should be OFF.
- Refer to the Circuit Diagram for quick pinpoint check.

If you need to check circuit continuity between harness connectors in more detail, such as when a sub-harness is used, refer to Wiring Diagram in each individual section and Harness Layout in PG section for identification of harness connectors.

- Before checking voltage at connectors, check battery voltage.
- After accomplishing the Diagnosis Procedures and Electrical Components Inspection, make sure that all harness connectors are reconnected as they were.

How to Follow Test Groups in Trouble Diagnosis

INFOID:000000001178869

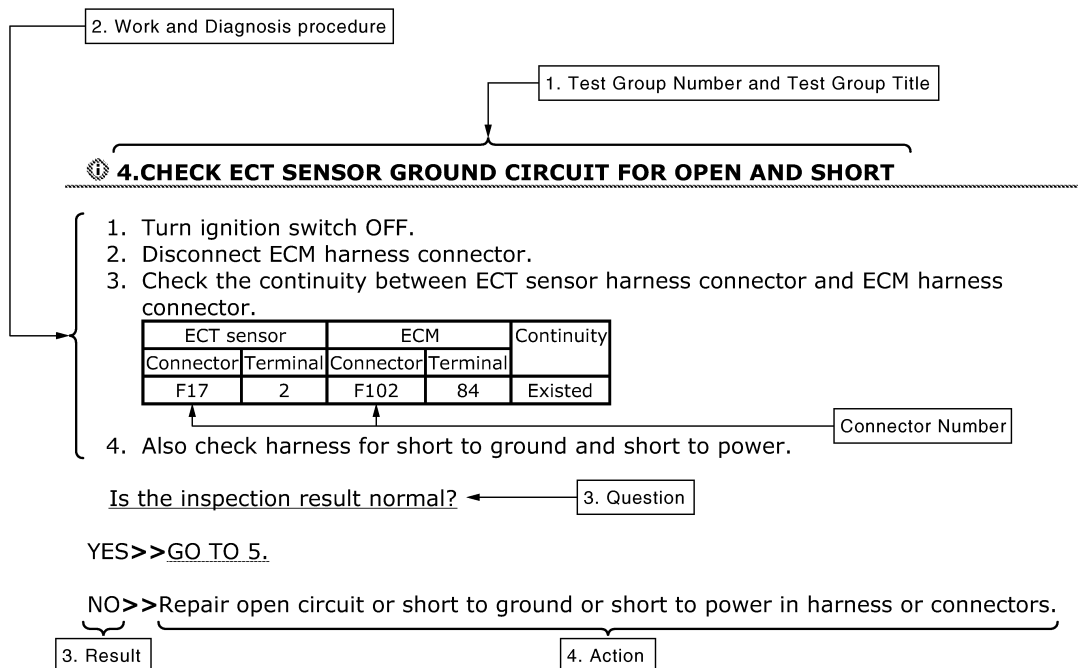

JPAIA0021GB





















1. Test group number and test group title
 - Test group number and test group title are shown in the upper portion of each test group.
2. Work and diagnosis procedure
 - Start to diagnose a problem using procedures indicated in enclosed test groups.
3. Questions and results
 - Questions and required results are indicated in test group.
4. Action
 - Next action for each test group is indicated based on result of each question.

HOW TO FOLLOW TROUBLE DIAGNOSES

< HOW TO USE THIS MANUAL >

Key to Symbols Signifying Measurements or Procedures

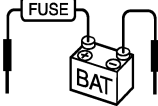
INFOID:000000001178870

SYMBOL	DESCRIPTION	SYMBOL	DESCRIPTION
	Check after disconnecting the connector to be measured.		Procedure with Generic Scan Tool. (GST, OBD-II scan tool)
	Check after connecting the connector to be measured.		Procedure without CONSULT-II, CONSULT-III or GST
	Insert key into ignition switch.		A/C switch is "OFF".
	Remove key from ignition switch.		A/C switch is "ON".
	Insert and remove key repeatedly.		REC switch is "ON".
	Turn ignition switch to "OFF" position.		REC switch is "OFF".
	Turn ignition switch to "ACC" position.		Fan switch is "ON". (At any position except for "OFF" position)
	Turn ignition switch to "ON" position.		Fan switch is "OFF".
	Turn ignition switch to "START" position.		Apply fuse.
	Turn ignition switch from "OFF" to "ACC" position.		Apply positive voltage from battery with fuse directly to components.
	Turn ignition switch from "ACC" to "ON" position.		
	Turn ignition switch from "ACC" to "OFF" position.		

SAIA1539E

GI

B

C

D

E

F

G

H

I

J

K

L

M

























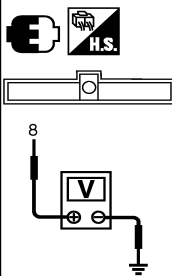

N

O

P

HOW TO FOLLOW TROUBLE DIAGNOSES

< HOW TO USE THIS MANUAL >

SYMBOL	DESCRIPTION	SYMBOL	DESCRIPTION
	Turn ignition switch from "OFF" to "ON" position.		Drive vehicle.
	Turn ignition switch from "ON" to "OFF" position.		
	Do not start engine, or check with engine stopped.		Disconnect battery negative cable.
	Start engine, or check with engine running.		Depress brake pedal.
	Apply parking brake.		Release brake pedal.
	Release parking brake.		Depress accelerator pedal.
	Check after engine is warmed up sufficiently.		Release accelerator pedal.
	Voltage should be measured with a voltmeter.	 <p>Pin terminal check for SMJ type ECM or TCM connectors. For details regarding the terminal arrangement, refer to the "ELECTRICAL UNITS" electrical reference page at the end of the manual.</p>	
	Circuit resistance should be measured with an ohmmeter.		
	Current should be measured with an ammeter.		
	Pulse signal should be checked with an oscilloscope.		
	Procedure with CONSULT-III		
	Procedure without CONSULT-III		
	Place selector lever in "P" position.		
	Place selector lever in "N" position.		
	Jack up front portion.		
	Jack up rear portion.		
	Inspect under engine room.		
	Inspect under floor.		
	Inspect rear under floor.		

SAIA1540E

HOW TO READ WIRING DIAGRAMS

< HOW TO USE THIS MANUAL >

HOW TO READ WIRING DIAGRAMS

Connector symbols

INFOID:000000001178871

Most of connector symbols in wiring diagrams are shown from the terminal side.

- Connector symbols shown from the terminal side are enclosed by a single line and followed by the direction mark.
- Connector symbols shown from the harness side are enclosed by a double line and followed by the direction mark.
- Certain systems and components, especially those related to OBD, may use a new style slide-locking type harness connector. For description and how to disconnect, refer to PG section, "Description", "HARNESS CONNECTOR".

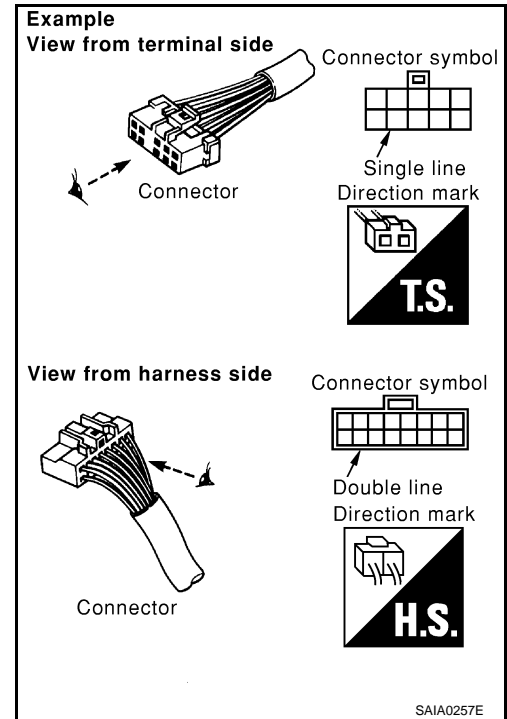

- Male and female terminals
Connector guides for male terminals are shown in black and female terminals in white in wiring diagrams.

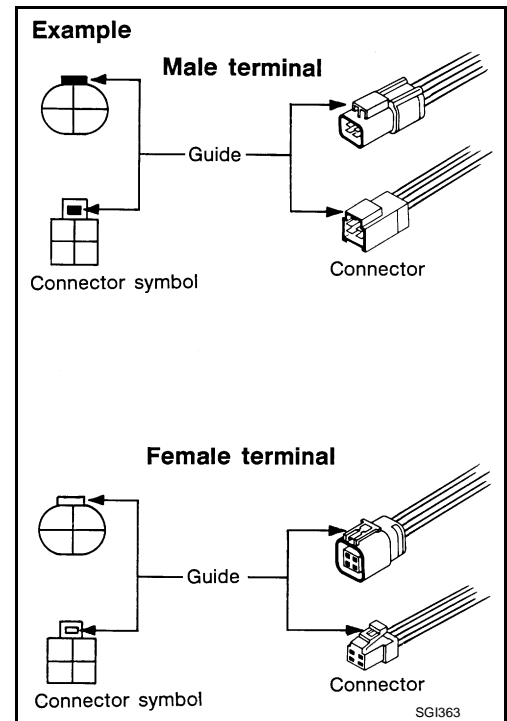

HOW TO READ WIRING DIAGRAMS

< HOW TO USE THIS MANUAL >

Sample/wiring diagram -example-

INFOID:000000001178872

- For detail, refer to following [GI-11. "Description"](#).

EXAMPL

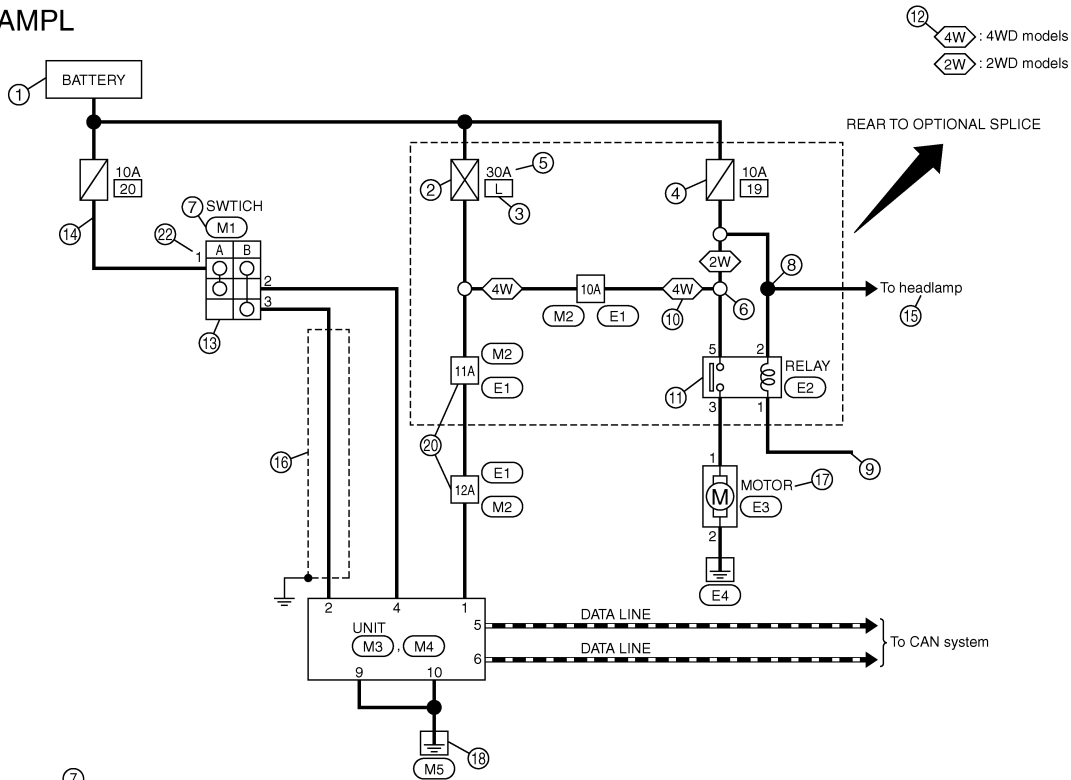

Connector No.	M3
Connector Name	UNIT
Connector Type	NS06FW-M2

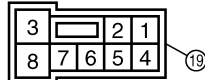

Connector No.	M4
Connector Name	UNIT
Connector Type	NS10FW-CS

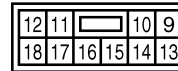

Terminal No.	Color of Wire	Signal Name [Specification]
1	W	BAT
2	G	SWITCH B
4	V	SWITCH A
5	L	CAN-H
6	P	CAN-L

Terminal No.	Color of Wire	Signal Name [Specification]
9	B	GND
10	B	GND

Optional splice

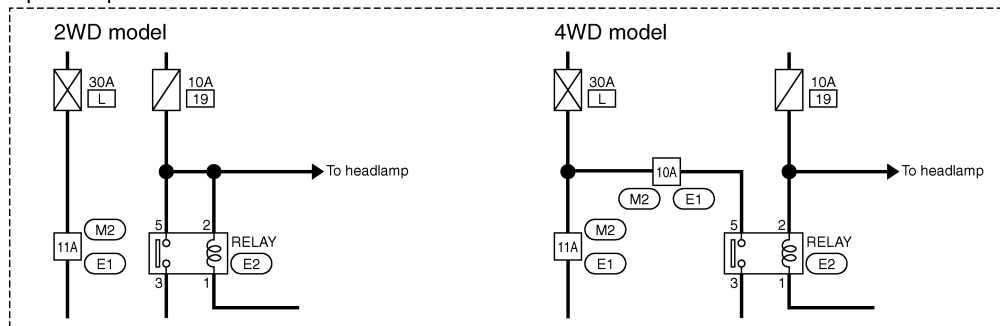

JCAWA0005GE

HOW TO READ WIRING DIAGRAMS

< HOW TO USE THIS MANUAL >

Description

INFOID:000000001178873

GI

Number	Item	Description														
1	Power supply	• This means the power supply of fusible link or fuse.														
2	Fusible link	• "X" means the fusible link.														
3	Number of fusible link/fuse	• This means the number of fusible link or fuse location.														
4	Fuse	• "f" means the fuse.														
5	Current rating of fusible link/fuse	• This means the current rating of the fusible link or fuse.														
6	Optional splice	• The open circle shows that the splice is optional depending on vehicle application.														
7	Connector number	• The letter shows which harness the connector is located in. • Example "M": main harness. For detail and to locate the connector, refer to PG-70, "LHD : How To Read Harness Layout" , PG-72, "LHD : Main Harness" .														
8	Splice	• The shaded circle "●" means the splice.														
9	Page crossing	• This circuit continues to an adjacent page.														
10	Option abbreviation	• This means the vehicle specifications which layouts the circuit between "O".														
11	Relay	• This shows an internal representation of the relay.														
12	Option description	• This shows a description of the option abbreviation used on the page.														
13	Switch	• This shows that continuity exists between terminals 1 and 2 when the switch is in the A position. Continuity exists between terminals 1 and 3 when the switch is in the B position.														
14	Circuit (Wiring)	• This means the wiring.														
15	System branch	• This shows that the circuit is branched to other systems.														
16	Shielded line	• The line enclosed by broken line circle shows shield wire.														
17	Component name	• This shows the name of a component.														
18	Ground (GND)	• This shows the ground connection.														
19	Connector	• This means the connector information. • This unit-side is described by the connector symbols.														
20	Connectors	• This means that a transmission line bypasses two connectors or more.														
21	Wire color	• This shows a code for the color of the wire.														
		<table border="0"> <tr> <td>B = Black</td> <td>BR = Brown</td> </tr> <tr> <td>W = White</td> <td>OR or O = Orange</td> </tr> <tr> <td>R = Red</td> <td>P = Pink</td> </tr> <tr> <td>G = Green</td> <td>PU or V (Violet) = Purple</td> </tr> <tr> <td>L = Blue</td> <td>GY or GR = Gray</td> </tr> <tr> <td>Y = Yellow</td> <td>SB = Sky Blue</td> </tr> <tr> <td>LG = Light Green</td> <td>CH = Dark Brown</td> </tr> <tr> <td></td> <td>DG = Dark Green</td> </tr> </table>	B = Black	BR = Brown	W = White	OR or O = Orange	R = Red	P = Pink	G = Green	PU or V (Violet) = Purple	L = Blue	GY or GR = Gray	Y = Yellow	SB = Sky Blue	LG = Light Green	CH = Dark Brown
B = Black	BR = Brown															
W = White	OR or O = Orange															
R = Red	P = Pink															
G = Green	PU or V (Violet) = Purple															
L = Blue	GY or GR = Gray															
Y = Yellow	SB = Sky Blue															
LG = Light Green	CH = Dark Brown															
	DG = Dark Green															
		• When the wire color is striped, the base color is given first, followed by the stripe color as shown below: Example: L/W = Blue with White Stripe														
22	Terminal number	• This means the terminal number of a connector.														

SWITCH POSITIONS

Switches are shown in wiring diagrams as if the vehicle is in the "normal" condition.
A vehicle is in the "normal" condition when:

HOW TO READ WIRING DIAGRAMS

< HOW TO USE THIS MANUAL >

- ignition switch is "OFF",
- doors, hood and trunk lid/back door are closed,
- pedals are not depressed, and
- parking brake is released.

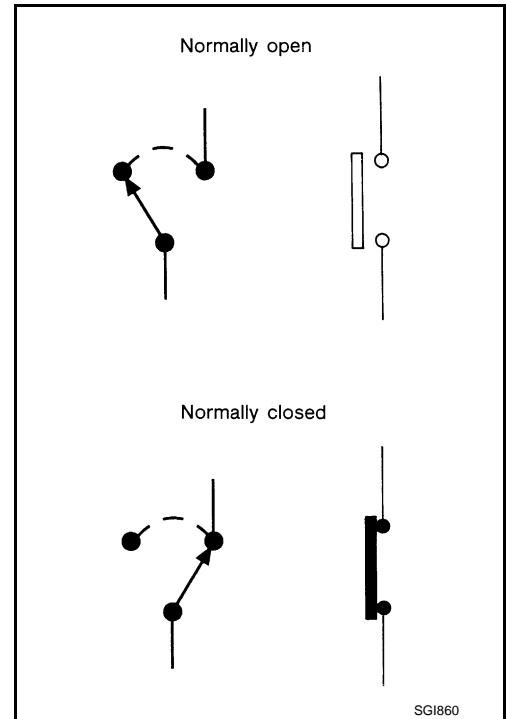

MULTIPLE SWITCH

The continuity of multiple switch is described in two ways as shown below.

- The switch chart is used in schematic diagrams.
- The switch diagram is used in wiring diagrams.

Example

(SWITCH CHART)

WIPER SWITCH		OFF	INT	LO	HI	WASH
1						○
2					○	
3	○	○	○			
4	○	○				
5		○				
6		○	○	○	○	

(SWITCH DIAGRAM)

Both switches are turned in combination.

Continuity circuit of wiper switch

SWITCH POSITION	CONTINUITY CIRCUIT
OFF	3-4
INT	3-4, 5-6
LO	3-6
HI	2-6
WASH	1-6

JSAIA0017GB

ABBREVIATIONS

< HOW TO USE THIS MANUAL >

ABBREVIATIONS

Abbreviation List

INFOID:000000001178874

GI

The following **ABBREVIATIONS** are used:

ABBREVIATION	DESCRIPTION
A/C	Air Conditioner
A/T	Automatic Transaxle/Transmission
ATF	Automatic Transmission Fluid
D1	Drive range 1st gear
D2	Drive range 2nd gear
D3	Drive range 3rd gear
D4	Drive range 4th gear
FR, RR	Front, Rear
LH, RH	Left-Hand, Right-Hand
M/T	Manual Transaxle/Transmission
OD	Overdrive
P/S	Power Steering
SAE	Society of Automotive Engineers, Inc.
SDS	Service Data and Specifications
SST	Special Service Tools
2WD	2-Wheel Drive
22	2nd range 2nd gear
21	2nd range 1st gear
12	1st range 2nd gear
11	1st range 1st gear

B

C

D

E

F

G

H

I

J

K

L

M

N

O

P

TIGHTENING TORQUE OF STANDARD BOLTS

< HOW TO USE THIS MANUAL >

TIGHTENING TORQUE OF STANDARD BOLTS

Description

INFOID:000000001178875

This vehicle has both new standard based on ISO* and previous standard bolts/nuts. There are some differences between these two types of bolts/ nuts; shape of the head, grade of strength, hexagonal width across flats and the standard tightening torque.

- For guidance in discriminating, refer to [GI-14, "Tightening Torque Table \(New Standard Included\)"](#).
- The new standard machine screws and tapping screws have a head of ISO standard torx recess.
- If the tightening torque is not described in the description or figure, refer to [GI-14, "Tightening Torque Table \(New Standard Included\)"](#).

*ISO: International Organization for Standardization

Tightening Torque Table (New Standard Included)

INFOID:000000001178876

CAUTION:

- The special parts are excluded.
- The bolts/nuts in these tables have a strength (discrimination) number/symbol assigned to the head or the like. As to the relation between the strength grade in these tables and the strength (discrimination) number/symbol, refer to “DISCRIMINATION OF BOLTS AND NUTS”.

PREVIOUS STANDARD

Grade (Strength grade)	Bolt size	Bolt di- ameter mm	Hexagonal width across flats mm	Pitch mm	Tightening torque (Without lubricant)							
					Hexagon head bolt				Hexagon flange bolt			
					N-m	kg-m	ft-lb	in-lb	N-m	kg-m	ft-lb	in-lb
4T	M6	6.0	10	1.0	5.5	0.56	4	49	7	0.71	5	62
	M8	8.0	12	1.25	13.5	1.4	10	—	17	1.7	13	—
				1.0	13.5	1.4	10	—	17	1.7	13	—
	M10	10.0	14	1.5	28	2.9	21	—	35	3.6	26	—
				1.25	28	2.9	21	—	35	3.6	26	—
	M12	12.0	17	1.75	45	4.6	33	—	55	5.6	41	—
1.25				45	4.6	33	—	65	6.6	48	—	
M14	14.0	19	1.5	80	8.2	59	—	100	10	74	—	
7T	M6	6.0	10	1.0	9	0.92	7	80	11	1.1	8	97
	M8	8.0	12	1.25	22	2.2	16	—	28	2.9	21	—
				1.0	22	2.2	16	—	28	2.9	21	—
	M10	10.0	14	1.5	45	4.6	33	—	55	5.6	41	—
				1.25	45	4.6	33	—	55	5.6	41	—
	M12	12.0	17	1.75	80	8.2	59	—	100	10	74	—
1.25				80	8.2	59	—	100	10	74	—	
M14	14.0	19	1.5	130	13	96	—	170	17	125	—	
9T	M6	6.0	10	1.0	11	1.1	8	—	13.5	1.4	10	—
	M8	8.0	12	1.25	28	2.9	21	—	35	3.6	26	—
				1.0	28	2.9	21	—	35	3.6	26	—
	M10	10.0	14	1.5	55	5.6	41	—	80	8.2	59	—
				1.25	55	5.6	41	—	80	8.2	59	—
	M12	12.0	17	1.75	100	10	74	—	130	13	96	—
1.25				100	10	74	—	130	13	96	—	
M14	14.0	19	1.5	170	17	125	—	210	21	155	—	

CAUTION:

TIGHTENING TORQUE OF STANDARD BOLTS

< HOW TO USE THIS MANUAL >

The parts with aluminum or the cast iron washer surface/screw surface are excluded.

NEW STANDARD BASED ON ISO

GI

Grade (Strength grade)	Bolt size	Bolt di- ameter mm	Hexagonal width across flats mm	Pitch mm	Tightening torque							
					Hexagon head bolt				Hexagon flange bolt			
					N-m	kg-m	ft-lb	in-lb	N-m	kg-m	ft-lb	in-lb
4.8 (Without lubricant)	M6	6.0	10	1.0	5.5	0.56	4	49	7	0.71	5	62
	M8	8.0	13	1.25	13.5	1.4	10	—	17	1.7	13	—
				1.0	13.5	1.4	10	—	17	1.7	13	—
	M10	10.0	16	1.5	28	2.9	21	—	35	3.6	26	—
				1.25	28	2.9	21	—	35	3.6	26	—
	M12	12.0	18	1.75	45	4.6	33	—	55	5.6	41	—
1.25				45	4.6	33	—	65	6.6	48	—	
M14	14.0	21	1.5	80	8.2	59	—	100	10	74	—	
4.8 (With lu- bricant)	M6	6.0	10	1.0	4	0.41	3	35	5.5	0.56	4	49
	M8	8.0	13	1.25	11	1.1	8	—	13.5	1.4	10	—
				1.0	11	1.1	8	—	13.5	1.4	10	—
	M10	10.0	16	1.5	22	2.2	16	—	28	2.9	21	—
				1.25	22	2.2	16	—	28	2.9	21	—
	M12	12.0	18	1.75	35	3.6	26	—	45	4.6	33	—
1.25				35	3.6	26	—	45	4.6	33	—	
M14	14.0	21	1.5	65	6.6	48	—	80	8.2	59	—	
8.8 (With lu- bricant)	M6	6.0	10	1.0	8	0.82	6	71	10	1.0	7	89
	M8	8.0	13	1.25	21	2.1	15	—	25	2.6	18	—
				1.0	21	2.1	15	—	25	2.6	18	—
	M10	10.0	16	1.5	40	4.1	30	—	50	5.1	37	—
				1.25	40	4.1	30	—	50	5.1	37	—
	M12	12.0	18	1.75	70	7.1	52	—	85	8.7	63	—
1.25				70	7.1	52	—	85	8.7	63	—	
M14	14.0	21	1.5	120	12	89	—	140	14	103	—	
10.9 (With lu- bricant)	M6	6.0	10	1.0	10	1.0	7	89	12	1.2	9	106
	M8	8.0	13	1.25	27	2.8	20	—	32	3.3	24	—
				1.0	27	2.8	20	—	32	3.3	24	—
	M10	10.0	16	1.5	55	5.6	41	—	62	6.3	46	—
				1.25	55	5.6	41	—	62	6.3	46	—
	M12	12.0	18	1.75	95	9.7	70	—	105	11	77	—
1.25				95	9.7	70	—	105	11	77	—	
M14	14.0	21	1.5	160	16	118	—	180	18	133	—	

CAUTION:

- Use tightening torque with lubricant for the new standard bolts/nuts in principle. Friction coefficient stabilizer is applied to the new standard bolts/nuts.
- However, use tightening torque without lubricant for the following cases. Friction coefficient stabilizer is not applied to the following bolts/nuts.
 - Grade 4.8, M6 size bolt, Conical spring washer installed
 - Paint removing nut (Size M6 and M8) for fixing with weld bolt

TIGHTENING TORQUE OF STANDARD BOLTS

< HOW TO USE THIS MANUAL >

DISCRIMINATION OF BOLTS AND NUTS

BOLTS

	Grade (Strength)	Discrimination	
Previous standard	4T (392N/mm ²)		 (No number/ symbol)
	7T (686N/mm ²)		
	9T (883N/mm ²)		
New Standard	4.8 (420N/mm ²)		 (No number/ symbol)
	8.8 (800N/mm ²)		
	10.9 (1040N/mm ²)		

NUTS

	Grade (Proof load stress)	Discrimination		
Previous standard	7N (686N/mm ²)	 (No number/ symbol)		
	9N (883N/mm ²)			
New Standard	8 (800N/mm ²)			 (No number/ symbol)
	10 (1040N/mm ²)			

NOTICE:

- A number is assigned on the side of the nuts in some cases.
- A number or symbol is assigned on the upper surface of the flange for the nut with flange.

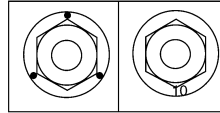

MACHINE SCREWS AND TAPPING SCREWS

Shape of the head :

Cross recess for the previous standard

Torx recess for the new standard

Screw size	Screw diameter	Torx size
M4	4.0	T20
M5	5.0	T20
M6	6.0	T30

NOTICE:

Use torx size T20 (united with M4 screw) for M5 screw although ISO standard specifies T25.

SAIA0453E

TERMINOLOGY

< HOW TO USE THIS MANUAL >

TERMINOLOGY

SAE J1930 Terminology List

INFOID:000000001178877

All emission related terms used in this publication in accordance with SAE J1930 are listed. Accordingly, new terms, new acronyms/abbreviations and old terms are listed in the following chart.

NEW TERM	NEW ACRONYM / ABBREVIATION	OLD TERM
Air cleaner	ACL	Air cleaner
Barometric pressure	BARO	***
Barometric pressure sensor-BCDD	BAROS-BCDD	BCDD
Camshaft position	CMP	***
Camshaft position sensor	CMPS	Crank angle sensor
Canister	***	Canister
Carburetor	CARB	Carburetor
Charge air cooler	CAC	Intercooler
Closed loop	CL	Closed loop
Closed throttle position switch	CTP switch	Idle switch
Clutch pedal position switch	CPP switch	Clutch switch
Continuous fuel injection system	CFI system	***
Continuous trap oxidizer system	CTOX system	***
Crankshaft position	CKP	***
Crankshaft position sensor	CKPS	***
Data link connector	DLC	***
Diagnostic test mode	DTM	Diagnostic mode
Diagnostic test mode selector	DTM selector	Diagnostic mode selector
Diagnostic test mode I	DTM I	Mode I
Diagnostic test mode II	DTM II	Mode II
Diagnostic trouble code	DTC	Malfunction code
Direct fuel injection system	DFI system	***
Distributor ignition system	DI system	Ignition timing control
Early fuel evaporation-mixture heater	EFE-mixture heater	Mixture heater
Early fuel evaporation system	EFE system	Mixture heater control
Electrically erasable programmable read only memory	EEPROM	***
Electronic ignition system	EI system	Ignition timing control
Engine control	EC	***
Engine control module	ECM	ECCS control unit
Engine coolant temperature	ECT	Engine temperature
Engine coolant temperature sensor	ECTS	Engine temperature sensor
Engine modification	EM	***
Engine speed	RPM	Engine speed
Erasable programmable read only memory	EPROM	***
Evaporative emission canister	EVAP canister	Canister
Evaporative emission system	EVAP system	Canister control solenoid valve
Exhaust gas recirculation valve	EGR valve	EGR valve

TERMINOLOGY

< HOW TO USE THIS MANUAL >

NEW TERM	NEW ACRONYM / ABBREVIATION	OLD TERM
Exhaust gas recirculation control-BPT valve	EGRC-BPT valve	BPT valve
Exhaust gas recirculation control-solenoid valve	EGRC-solenoid valve	EGR control solenoid valve
Exhaust gas recirculation temperature sensor	EGRT sensor	Exhaust gas temperature sensor
EGR temperature sensor		
Flash electrically erasable programmable read only memory	FEEPROM	***
Flash erasable programmable read only memory	FEPROM	***
Flexible fuel sensor	FFS	***
Flexible fuel system	FF system	***
Fuel pressure regulator	***	Pressure regulator
Fuel pressure regulator control solenoid valve	***	PRVR control solenoid valve
Fuel trim	FT	***
Heated Oxygen sensor	HO2S	Exhaust gas sensor
Idle air control system	IAC system	Idle speed control
Idle air control valve-air regulator	IACV-air regulator	Air regulator
Idle air control valve-auxiliary air control valve	IACV-AAC valve	Auxiliary air control (AAC) valve
Idle air control valve-FICD solenoid valve	IACV-FICD solenoid valve	FICD solenoid valve
Idle air control valve-idle up control solenoid valve	IACV-idle up control solenoid valve	Idle up control solenoid valve
Idle speed control-FI pot	ISC-FI pot	FI pot
Idle speed control system	ISC system	***
Ignition control	IC	***
Ignition control module	ICM	***
Indirect fuel injection system	IFI system	***
Intake air	IA	Air
Intake air temperature sensor	IAT sensor	Air temperature sensor
Knock	***	Detonation
Knock sensor	KS	Detonation sensor
Malfunction indicator lamp	MIL	Check engine light
Manifold absolute pressure	MAP	***
Manifold absolute pressure sensor	MAPS	***
Manifold differential pressure	MDP	***
Manifold differential pressure sensor	MDPS	***
Manifold surface temperature	MST	***
Manifold surface temperature sensor	MSTS	***
Manifold vacuum zone	MVZ	***
Manifold vacuum zone sensor	MVZS	***
Mass air flow sensor	MAFS	Air flow meter
Mixture control solenoid valve	MC solenoid valve	Air-fuel ratio control solenoid valve
Multiport fuel injection system	MFI system	Fuel injection control

TERMINOLOGY

< HOW TO USE THIS MANUAL >

NEW TERM	NEW ACRONYM / ABBREVIATION	OLD TERM	GI
Nonvolatile random access memory	NVRAM	***	
On board diagnostic system	OBD system	Self-diagnosis	B
Open loop	OL	Open loop	
Oxidation catalyst	OC	Catalyst	C
Oxidation catalytic converter system	OC system	***	
Oxygen sensor	O2S	Exhaust gas sensor	
Park position switch	***	Park switch	D
Park/neutral position switch	PNP switch	Park/neutral switch Inhibitor switch Neutral position switch	
Periodic trap oxidizer system	PTOX system	***	E
Positive crankcase ventilation	PCV	Positive crankcase ventilation	
Positive crankcase ventilation valve	PCV valve	PCV valve	F
Powertrain control module	PCM	***	
Programmable read only memory	PROM	***	
Pulsed secondary air injection control solenoid valve	PAIRC solenoid valve	AIV control solenoid valve	G
Pulsed secondary air injection system	PAIR system	Air induction valve (AIV) control	
Pulsed secondary air injection valve	PAIR valve	Air induction valve	H
Random access memory	RAM	***	
Read only memory	ROM	***	I
Scan tool	ST	***	
Secondary air injection pump	AIR pump	***	
Secondary air injection system	AIR system	***	J
Sequential multipoint fuel injection system	SFI system	Sequential fuel injection	
Service reminder indicator	SRI	***	K
Simultaneous multipoint fuel injection system	***	Simultaneous fuel injection	
Smoke puff limiter system	SPL system	***	L
Supercharger	SC	***	
Supercharger bypass	SCB	***	
System readiness test	SRT	***	M
Thermal vacuum valve	TVV	Thermal vacuum valve	
Three way catalyst	TWC	Catalyst	N
Three way catalytic converter system	TWC system	***	
Three way + oxidation catalyst	TWC + OC	Catalyst	
Three way + oxidation catalytic converter system	TWC + OC system	***	O
Throttle body	TB	Throttle chamber SPI body	P
Throttle body fuel injection system	TBI system	Fuel injection control	
Throttle position	TP	Throttle position	
Throttle position sensor	TPS	Throttle sensor	
Throttle position switch	TP switch	Throttle switch	
Torque converter clutch solenoid valve	TCC solenoid valve	Lock-up cancel solenoid Lock-up solenoid	

TERMINOLOGY

< HOW TO USE THIS MANUAL >

NEW TERM	NEW ACRONYM / ABBREVIATION	OLD TERM
Transmission control module	TCM	A/T control unit
Turbocharger	TC	Turbocharger
Vehicle speed sensor	VSS	Vehicle speed sensor
Volume air flow sensor	VAFS	Air flow meter
Warm up oxidation catalyst	WU-OC	Catalyst
Warm up oxidation catalytic converter system	WU-OC system	***
Warm up three way catalyst	WU-TWC	Catalyst
Warm up three way catalytic converter system	WU-TWC system	***
Wide open throttle position switch	WOTP switch	Full switch

***: Not applicable

IDENTIFICATION INFORMATION

< FEATURES OF NEW MODEL >

FEATURES OF NEW MODEL

IDENTIFICATION INFORMATION

Model Variation

INFOID:000000001178878

Body	Axle	Engine	Transaxle	Grade	Destination	
					RHD for Europe	LHD for Southern/Central Europe
H/B	2WD	HR16	5MT	Visia	FDTARDF-EEA	FDTALDF-EGA
				Acenta/Tekna	FDTARGF-EEA	FDTALGF-EGA
				Acenta Pack/ Tekna Pack	FDTARHF-EEA	FDTALHF-EGA
		MR20	6MT	Visia	FDRARDY-EEA	FDRALDY-EGA
				Acenta/Tekna	FDRARGY-EEA	FDRALGY-EGA
				Acenta Pack/ Tekna Pack	FDRARHY-EEA	FDRALHY-EGA
			CVT	Visia	FDRARDZ-EEA	FDRALDZ-EGA
				Acenta/Tekna	FDRARGZ-EEA	FDRALGZ-EGA
				Acenta Pack/ Tekna Pack	FDRARHZ-EEA	FDRALHZ-EGA
		K9K	6MT	Visia	FTKARDY-TEA	FTKALDY-TGA
				Acenta/Tekna	FTKARGY-TEA	FTKALGY-TGA
				Acenta Pack/ Tekna Pack	FTKARHY-TEA	FTKALHY-TGA
	M9R		6MT	Visia	FTYARDY-TEA	FTYALDY-TGA
				Acenta/Tekna	FTYARGY-TEA	FTYALGY-TGA
				Acenta Pack/ Tekna Pack	FTYARHY-TEA	FTYALHY-TGA
	4WD	MR20	6MT	Visia	FDRNRDY-EEA	FDRNLDY-EGA
				Acenta/Tekna	FDRNRGY-EEA	FDRNLGY-EGA
				Acenta Pack/ Tekna Pack	FDRNRHY-EEA	FDRNLHY-EGA
			CVT	Visia	FDRNRDZ-EEA	FDRNLDZ-EGA
				Acenta/Tekna	FDRNRGZ-EEA	FDRNLGZ-EGA
				Acenta Pack/ Tekna Pack	FDRNRHZ-EEA	FDRNLHZ-EGA
		M9R	6AT	Visia	FTYNRDM-TEA	FTYNLDM-TGA
				Acenta/Tekna	FTYNRGM-TEA	FTYNLGM-TGA
				Acenta Pack/ Tekna Pack	FTYNRHM-TEA	FTYNLHM-TGA
6MT			Visia	FTYNRDY-TEA	FTYNLDY-TGA	
			Acenta/Tekna	FTYNRGY-TEA	FTYNLGY-TGA	
			Acenta Pack/ Tekna Pack	FTYNRHY-TEA	FTYNLHY-TGA	

GI

B

C

D

E

F

G

H

I

J

K

L

M

N

O

P

IDENTIFICATION INFORMATION

< FEATURES OF NEW MODEL >

Model variation code (Prefix and suffix designations) :

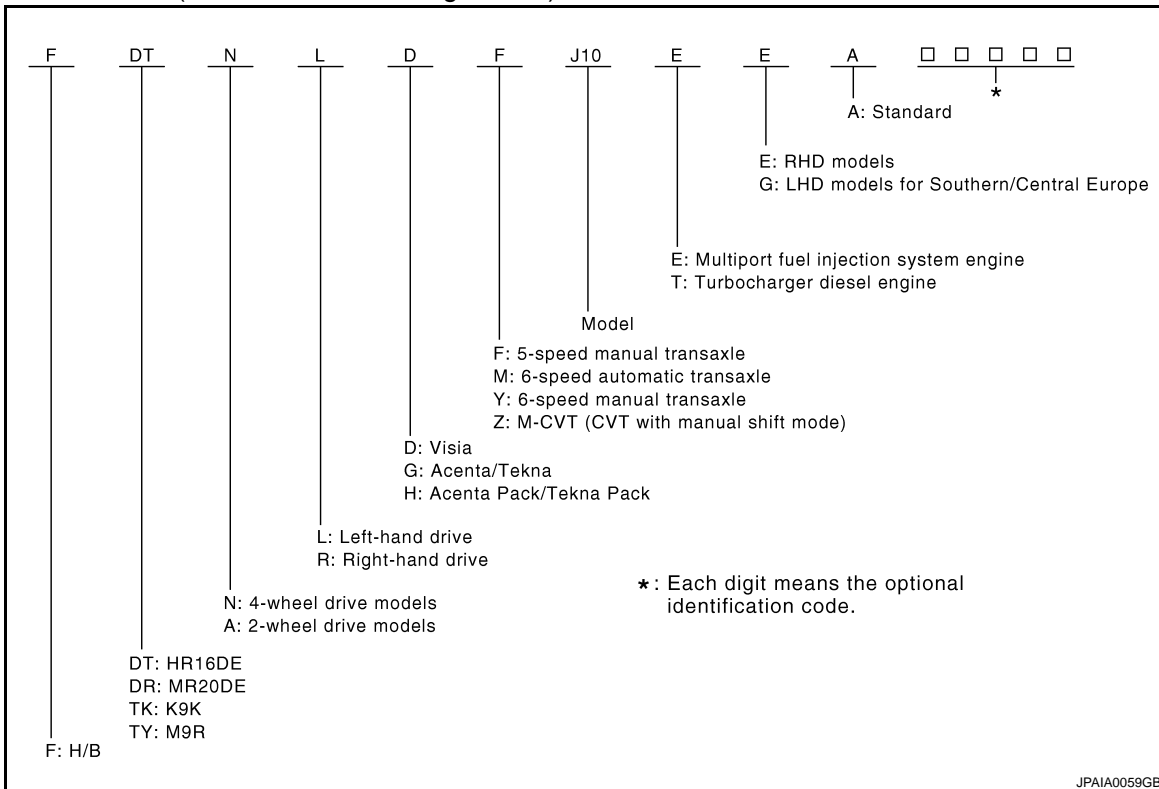

Information About Identification or Model Code

INFOID:000000001178879

IDENTIFICATION NUMBER

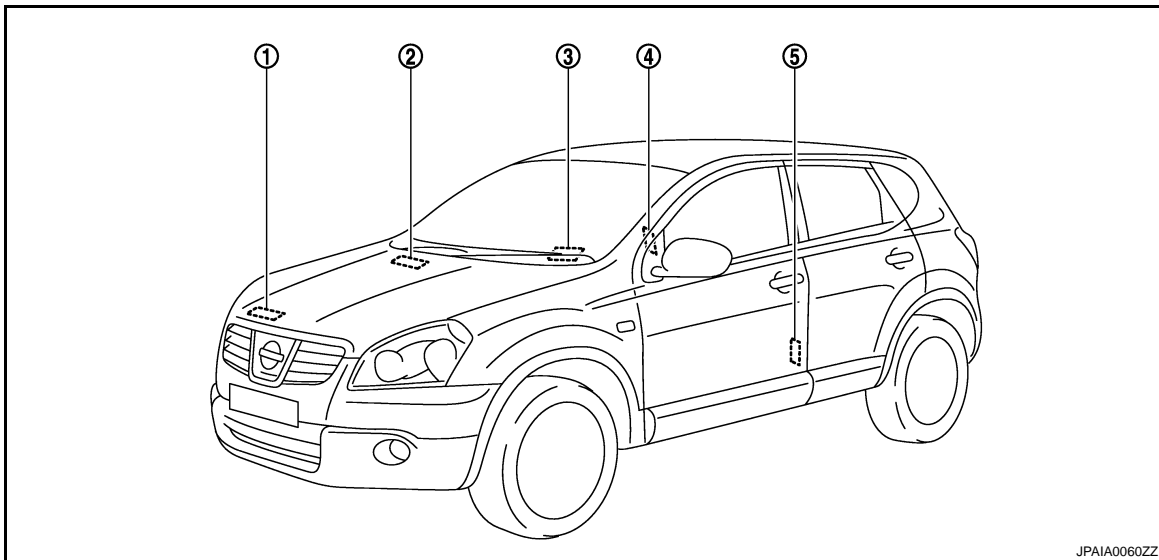

1. Air conditioner specification label
2. Vehicle identification number (Chassis number)
3. Vehicle identification number plate
4. Vehicle identification plate (RH side center pillar)
5. Tire placard

VEHICLE Identification Number ARRANGEMENT

IDENTIFICATION INFORMATION

< FEATURES OF NEW MODEL >

For Europe

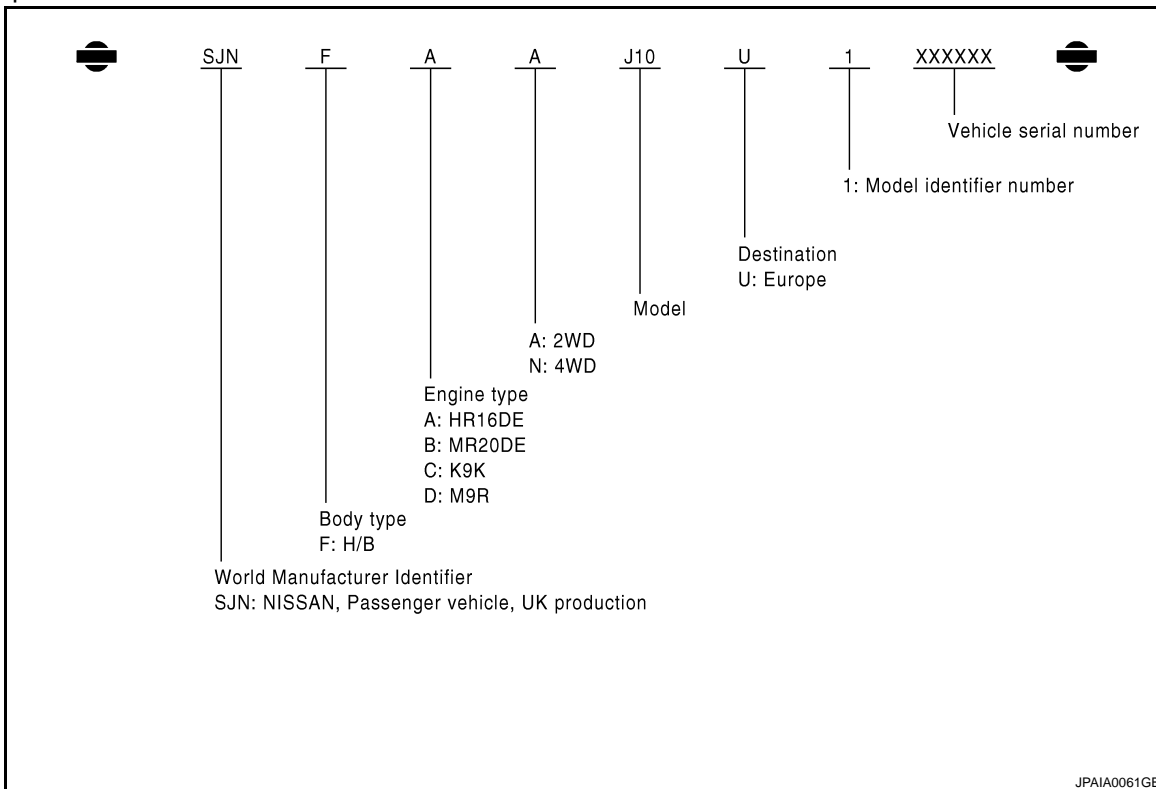

For Israel

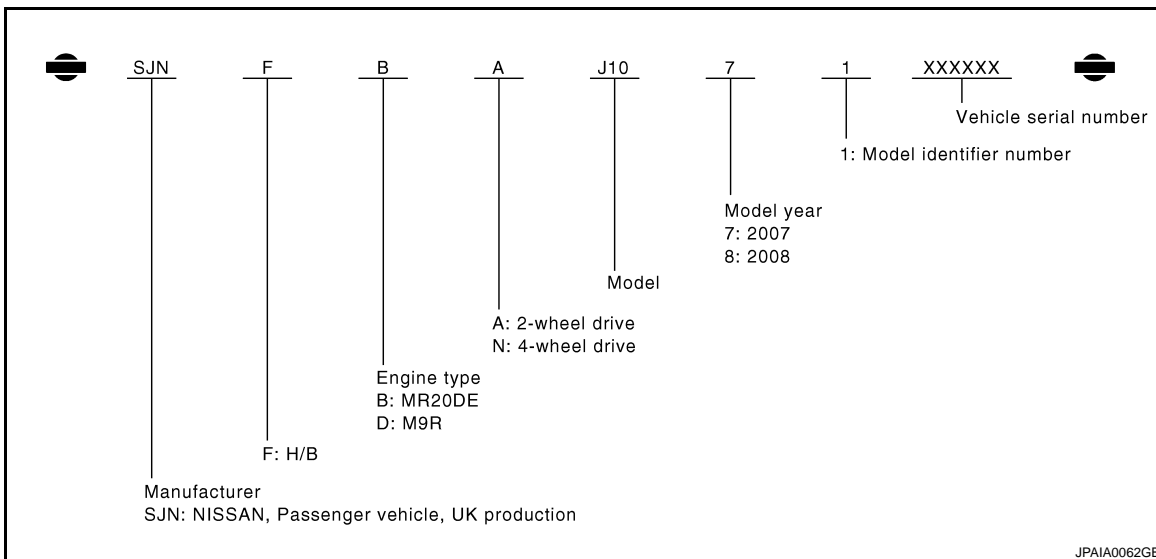

IDENTIFICATION PLATE

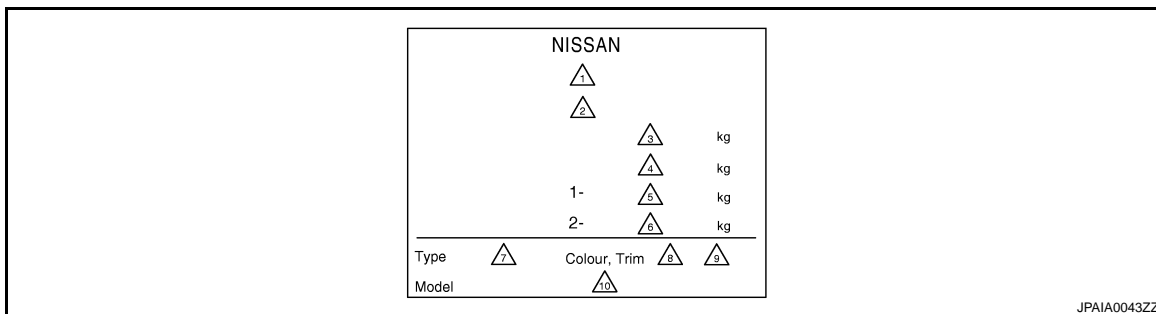

GI

B
C
D
E
F
G
H
I
J
K
L
M
N
O
P

IDENTIFICATION INFORMATION

< FEATURES OF NEW MODEL >

- | | | |
|---|---|-----------------------------|
| 1. Type approval number (Models for Europe with Euro-OBD system)
Blank (Models for Europe without Euro-OBD system) | 2. Vehicle identification number (Chassis number) | 3. Gross vehicle weight |
| 4. Gross combination weight
+ Gross trailing capacity (Weight) | 5. Gross axle weight (Front) | 6. Gross axle weight (Rear) |
| 7. Vehicle type | 8. Body color code | 9. Trim color code |
| 10. Model variation code | | |

ENGINE SERIAL NUMBER

HR and MR ENGINE

⇐ : Vehicle front

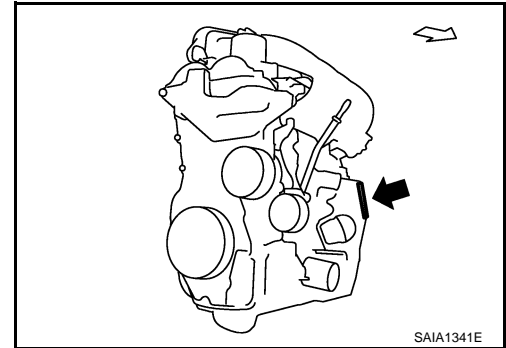

M9R ENGINE

⇐ : Vehicle front

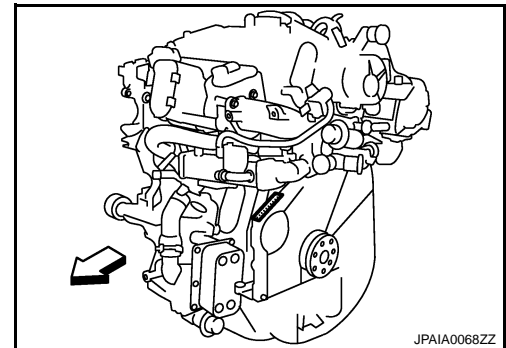

ENGINE IDENTIFICATION (K9K ENGINE)

IDENTIFICATION INFORMATION

< FEATURES OF NEW MODEL >

Identification is engraved on the cylinder block which carries:

- A: engine type,
- B: engine type approval letter,
- D: Renault code,
- E: engine suffix,
- F: engine fabrication number,
- G: engine assembly plant.

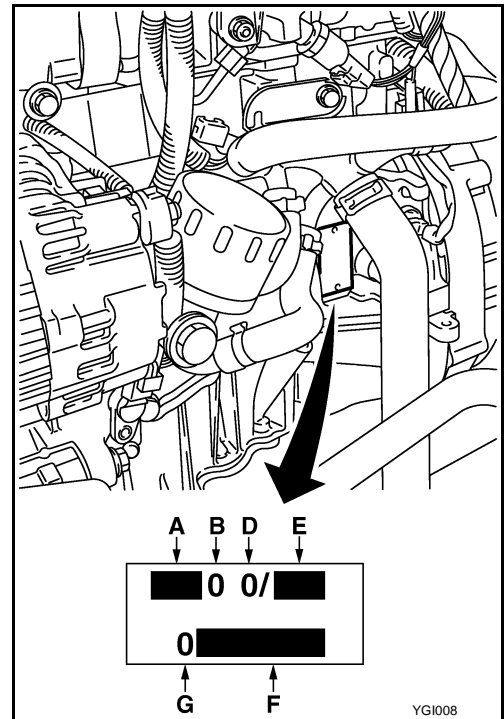

AUTOMATIC TRANSAXLE NUMBER

CVT Unit (RE0F10A)

↔ : Vehicle front

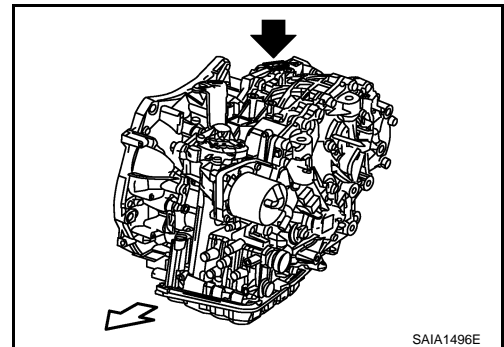

6AT (RE6F01A)

↔ : Vehicle front

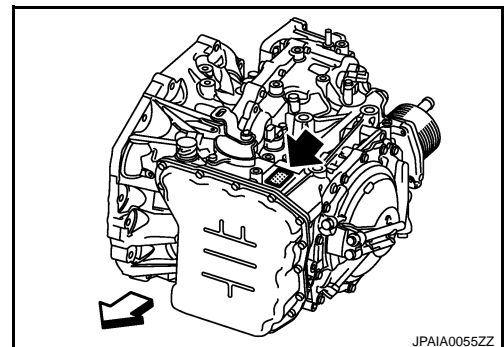

MANUAL TRANSAXLE NUMBER

5MT (RS5F92R)

1 : Serial number (bottom side of transaxle)

GI

B

C

D

E

F

G

H

I

J

K

L

M

N

O

P

IDENTIFICATION INFORMATION

< FEATURES OF NEW MODEL >

↩ : Vehicle front

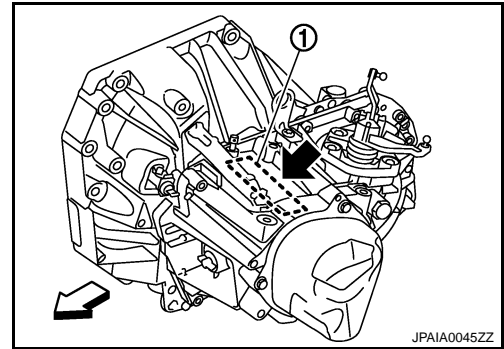

JPAIA0045ZZ

6MT (RS6F94R)

↩ : Vehicle front

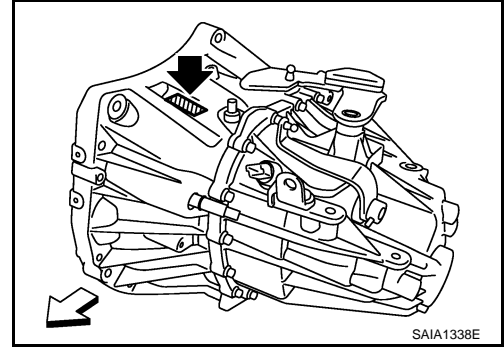

SAIA1338E

6MT (RS6F52A)

↩ : Vehicle front

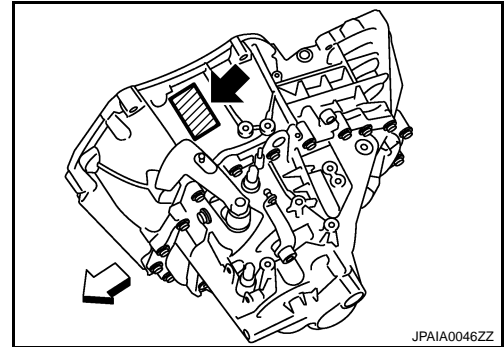

JPAIA0046ZZ

Dimensions

INFOID:000000001178880

Unit: mm (in)

Overall length	4,315 (169.9)
Overall width	1,780 (70.1)
Overall height	1,605 (63.2)
Front tread	1,540 (60.6)
Rear tread	1,545 (60.8)
Wheelbase	2,630 (103.5)

Wheels&Tires

INFOID:000000001178881

		Conventional	Spare
Road wheel/offset	mm (in)	16 × 6 1/2 JJ Aluminum/40 (1.57) 16 × 6 1/2 JJ Steel /40 (1.57) 17 × 6 1/2 JJ Aluminum/40 (1.57)	16 × 4T Steel/40 (1.57)
Tire size		215/65R16 98H 215/60R17 96H	T145/90D16 106M

PRECAUTIONS

< PRECAUTION >

PRECAUTION

PRECAUTIONS

Description

INFOID:000000001178882

Observe the following precautions to ensure safe and proper servicing. These precautions are not described in each individual section.

Precaution for Supplemental Restraint System (SRS) "AIR BAG" and "SEAT BELT PRE-TENSIONER"

INFOID:000000001587038

The Supplemental Restraint System such as "AIR BAG" and "SEAT BELT PRE-TENSIONER", used along with a front seat belt, helps to reduce the risk or severity of injury to the driver and front passenger for certain types of collision. This system includes seat belt switch inputs and dual stage front air bag modules. The SRS system uses the seat belt switches to determine the front air bag deployment, and may only deploy one front air bag, depending on the severity of a collision and whether the front occupants are belted or unbelted. Information necessary to service the system safely is included in the "SRS AIRBAG" and "SEAT BELT" of this Service Manual.

WARNING:

- To avoid rendering the SRS inoperative, which could increase the risk of personal injury or death in the event of a collision which would result in air bag inflation, all maintenance must be performed by an authorized NISSAN/INFINITI dealer.
- Improper maintenance, including incorrect removal and installation of the SRS, can lead to personal injury caused by unintentional activation of the system. For removal of Spiral Cable and Air Bag Module, see the "SRS AIRBAG".
- Do not use electrical test equipment on any circuit related to the SRS unless instructed to in this Service Manual. SRS wiring harnesses can be identified by yellow and/or orange harnesses or harness connectors.

Precautions For Xenon Headlamp Service

INFOID:000000001178884

WARNING:

Comply with the following warnings to prevent any serious accident.

- Disconnect the battery cable (negative terminal) or the power supply fuse before installing, removing, or touching the xenon headlamp (bulb included). The xenon headlamp contains high-voltage generated parts.
- Never work with wet hands.
- Check the xenon headlamp ON-OFF status after assembling it to the vehicle. Never turn the xenon headlamp ON in other conditions. Connect the power supply to the vehicle-side connector. (Turning it ON outside the lamp case may cause fire or visual impairments.)
- Never touch the bulb glass immediately after turning it OFF. It is extremely hot.

CAUTION:

Comply with the following cautions to prevent any error and malfunction.

- Install the xenon bulb securely. (Insufficient bulb socket installation may melt the bulb, the connector, the housing, etc. by high-voltage leakage or corona discharge.)
- Never perform HID circuit inspection with a tester.
- Never touch the xenon bulb glass with hands. Never put oil and grease on it.
- Dispose of the used xenon bulb after packing it in thick vinyl without breaking it.
- Never wipe out dirt and contamination with organic solvent (thinner, gasoline, etc.).

Precaution Necessary for Steering Wheel Rotation After Battery Disconnect

INFOID:000000001178885

NOTE:

- This Procedure is applied only to models with Intelligent Key system and NATS (NISSAN ANTI-THEFT SYSTEM).
- Remove and install all control units after disconnecting both battery cables with the ignition knob in the "LOCK" position.
- Always use CONSULT-III to perform self-diagnosis as a part of each function inspection after finishing work. If DTC is detected, perform trouble diagnosis according to self-diagnostic results.

PRECAUTIONS

< PRECAUTION >

For models equipped with the Intelligent Key system and NATS, an electrically controlled steering lock mechanism is adopted on the key cylinder.

For this reason, if the battery is disconnected or if the battery is discharged, the steering wheel will lock and steering wheel rotation will become impossible.

If steering wheel rotation is required when battery power is interrupted, follow the procedure below before starting the repair operation.

OPERATION PROCEDURE

1. Connect both battery cables.

NOTE:

Supply power using jumper cables if battery is discharged.

2. Use the Intelligent Key or mechanical key to turn the ignition switch to the "ACC" position. At this time, the steering lock will be released.
3. Disconnect both battery cables. The steering lock will remain released and the steering wheel can be rotated.
4. Perform the necessary repair operation.
5. When the repair work is completed, return the ignition switch to the "LOCK" position before connecting the battery cables. (At this time, the steering lock mechanism will engage.)
6. Perform a self-diagnosis check of all control units using CONSULT-III.

Precaution for Procedure without Cowl Top Cover

INFOID:000000001587040

When performing the procedure after removing cowl top cover, cover the lower end of windshield with urethane, etc.

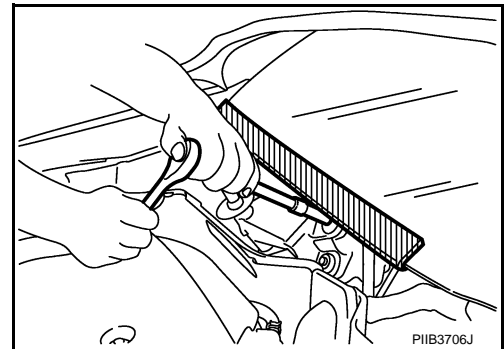

General Precautions

INFOID:000000001178887

- Do not operate the engine for an extended period of time without proper exhaust ventilation. Keep the work area well ventilated and free of any inflammable materials. Special care should be taken when handling any inflammable or poisonous materials, such as gasoline, refrigerant gas, etc. When working in a pit or other enclosed area, be sure to properly ventilate the area before working with hazardous materials. Do not smoke while working on the vehicle.

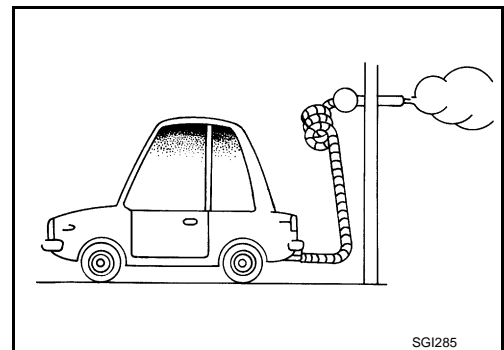

- Before jacking up the vehicle, apply wheel chocks or other tire blocks to the wheels to prevent the vehicle from moving. After jacking up the vehicle, support the vehicle weight with safety stands at the points designated for proper lifting before working on the vehicle. These operations should be done on a level surface.
- When removing a heavy component such as the engine or transaxle/transmission, be careful not to lose your balance and drop them. Also, do not allow them to strike adjacent parts, especially the brake tubes and master cylinder.

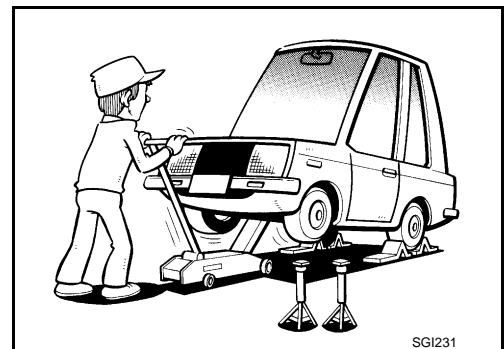

PRECAUTIONS

< PRECAUTION >

- Before starting repairs which do not require battery power:
Turn off ignition switch.
Disconnect the negative battery terminal.
- If the battery terminals are disconnected, recorded memory of radio and each control unit is erased.

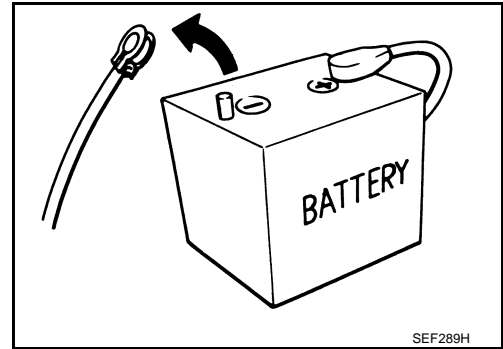

- To prevent serious burns:
Avoid contact with hot metal parts.
Do not remove the radiator cap when the engine is hot.
- Dispose of drained oil or the solvent used for cleaning parts in an appropriate manner.
- Do not attempt to top off the fuel tank after the fuel pump nozzle shuts off automatically.
Continued refueling may cause fuel overflow, resulting in fuel spray and possibly a fire.
- Clean all disassembled parts in the designated liquid or solvent prior to inspection or assembly.
- Replace oil seals, gaskets, packings, O-rings, locking washers, cotter pins, self-locking nuts, etc. with new ones.
- Replace inner and outer races of tapered roller bearings and needle bearings as a set.
- Arrange the disassembled parts in accordance with their assembled locations and sequence.
- Do not touch the terminals of electrical components which use microcomputers (such as ECM).
Static electricity may damage internal electronic components.
- After disconnecting vacuum or air hoses, attach a tag to indicate the proper connection.
- Use only the fluids and lubricants specified in this manual.
- Use approved bonding agent, sealants or their equivalents when required.
- Use hand tools, power tools (disassembly only) and recommended special tools where specified for safe and efficient service repairs.
- When repairing the fuel, oil, water, vacuum or exhaust systems, check all affected lines for leaks.

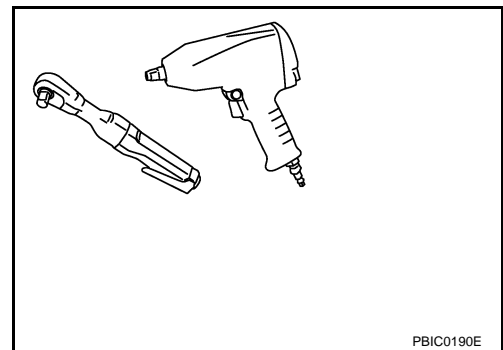
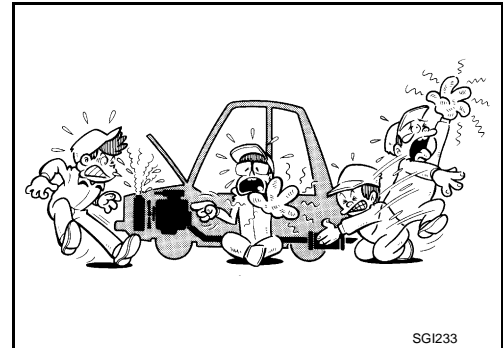

- Before servicing the vehicle:
Protect fenders, upholstery and carpeting with appropriate covers.
Take caution that keys, buckles or buttons do not scratch paint.

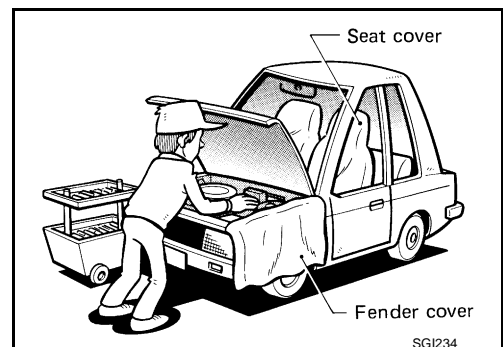

WARNING:

PRECAUTIONS

< PRECAUTION >

To prevent ECM from storing the diagnostic trouble codes, do not carelessly disconnect the harness connectors which are related to the engine control system and TCM (transmission control module) system. The connectors should be disconnected only when working according to the WORK FLOW of TROUBLE DIAGNOSES in EC and AT sections.

Three Way Catalyst

INFOID:000000001178888

If a large amount of unburned fuel flows into the catalyst, the catalyst temperature will be excessively high. To prevent this, follow the instructions.

- Use unleaded gasoline only. Leaded gasoline will seriously damage the three way catalyst.
- When checking for ignition spark or measuring engine compression, make tests quickly and only when necessary.
- Do not run engine when the fuel tank level is low, otherwise the engine may misfire, causing damage to the catalyst.

Do not place the vehicle on flammable material. Keep flammable material off the exhaust pipe and the three way catalyst.

Multipoint Fuel Injection System or Engine Control System

INFOID:000000001178889

- Before connecting or disconnecting any harness connector for the multipoint fuel injection system or ECM:
Turn ignition switch to "OFF" position.
Disconnect negative battery terminal.
Otherwise, there may be damage to ECM.
- Before disconnecting pressurized fuel line from fuel pump to injectors, be sure to release fuel pressure.
- Be careful not to jar components such as ECM and mass air flow sensor.

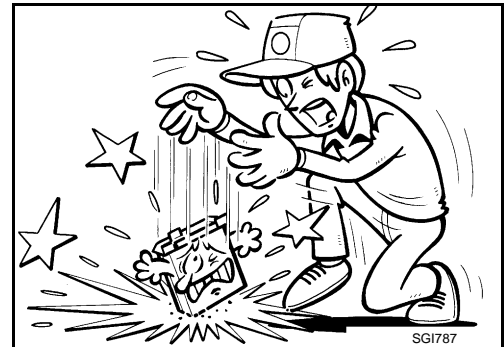

Turbocharger (If Equipped)

INFOID:000000001178890

The turbocharger turbine revolves at extremely high speeds and becomes very hot. Therefore, it is essential to maintain a clean supply of oil flowing through the turbocharger and to follow all required maintenance instructions and operating procedures.

- Always use the recommended oil. Follow the instructions for proper time to change the oil and proper oil level.
- Avoid accelerating engine to a high rpm immediately after starting.
- If engine had been operating at high rpm for an extended period of time, let it idle for a few minutes prior to shutting it off.

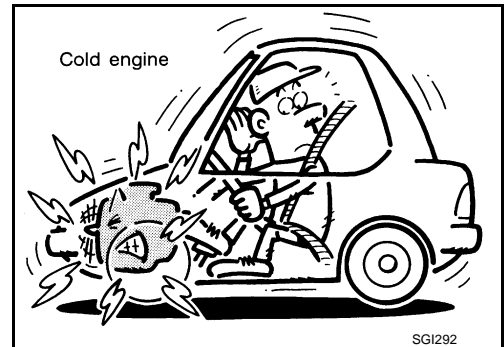

Hoses

INFOID:000000001178891

HOSE REMOVAL AND INSTALLATION

- To prevent damage to rubber hose, do not pry off rubber hose with tapered tool or screwdriver.

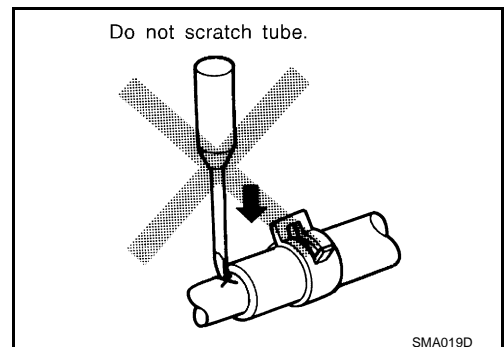

PRECAUTIONS

< PRECAUTION >

- To reinstall the rubber hose securely, make sure that hose insertion length and orientation is correct. (If tube is equipped with hose stopper, insert rubber hose into tube until it butts up against hose stopper.)

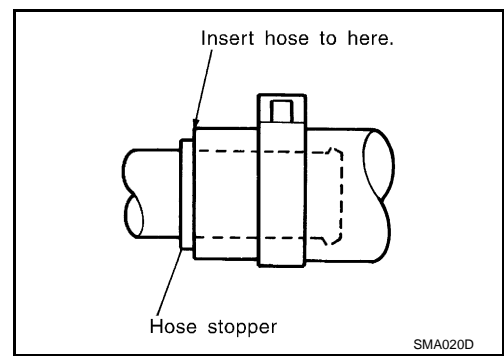

HOSE CLAMPING

- If old rubber hose is re-used, install hose clamp in its original position (at the indentation where the old clamp was). If there is a trace of tube bulging left on the old rubber hose, align rubber hose at that position.
- Discard old clamps; replace with new ones.

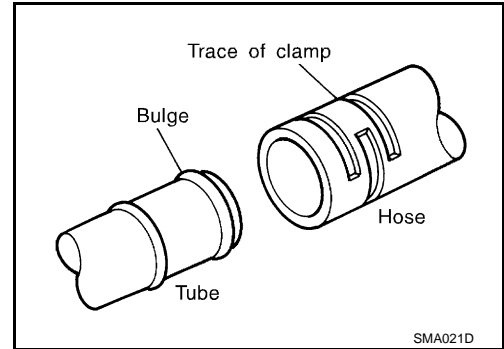

- After installing plate clamps, apply force to them in the direction of the arrow, tightening rubber hose equally all around.

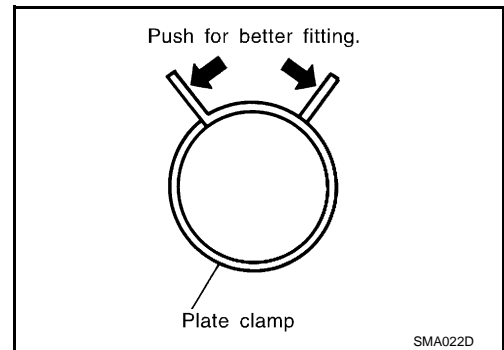

Engine Oils

INFOID:000000001178892

Prolonged and repeated contact with used engine oil may cause skin cancer. Try to avoid direct skin contact with used oil.

If skin contact is made, wash thoroughly with soap or hand cleaner as soon as possible.

HEALTH PROTECTION PRECAUTIONS

- Avoid prolonged and repeated contact with oils, particularly used engine oils.
- Wear protective clothing, including impervious gloves where practicable.
- Do not put oily rags in pockets.
- Avoid contaminating clothes, particularly underpants, with oil.
- Heavily soiled clothing and oil-impregnated footwear should not be worn. Overalls must be cleaned regularly.
- First aid treatment should be obtained immediately for open cuts and wounds.
- Use barrier creams, applying them before each work period, to help the removal of oil from the skin.
- Wash with soap and water to ensure all oil is removed (skin cleansers and nail brushes will help). Preparations containing lanolin replace the natural skin oils which have been removed.
- Do not use gasoline, kerosene, diesel fuel, gas oil, thinners or solvents for cleaning skin.
- If skin disorders develop, obtain medical advice without delay.
- Where practical, degrease components prior to handling.
- Where there is a risk of eye contact, eye protection should be worn, for example, chemical goggles or face shields; in addition an eye wash facility should be provided.

ENVIRONMENTAL PROTECTION PRECAUTIONS

PRECAUTIONS

< PRECAUTION >

Dispose of used oil and used oil filters through authorized waste disposal contractors to licensed waste disposal sites, or to the waste oil reclamation trade. If in doubt, contact the local authority for advice on disposal facilities.

It is illegal to pour used oil on to the ground, down sewers or drains, or into water sources. The regulations concerning pollution vary between regions.

Air Conditioning

INFOID:000000001178893

Use an approved refrigerant recovery unit any time the air conditioning system must be discharged. Refer to HA section "REFRIGERATION SYSTEM" for specific instructions.

FUEL

FUEL : Unleaded Premium Gasoline

INFOID:000000001178894

Use premium unleaded gasoline with an octane rating of at least 95 RON (research octane number). If premium unleaded gasoline is not available, regular unleaded gasoline with an octane rating of at least 91 RON (research octane number) can be used. However, for maximum vehicle performance, the use of premium unleaded gasoline is recommended.

CAUTION:

Do not use leaded gasoline. Using leaded gasoline will damage the three way catalyst. Using a fuel other than that specified could adversely affect the emission control devices and systems, and could also affect the warranty coverage validity.

FUEL : Diesel Engine Fuel

INFOID:000000001178895

Diesel fuel of at least 51 cetane for K9K engine and 50 cetane for M9R engine.

If two types of diesel fuel are available, use summer or winter fuel properly according to the following temperature conditions.

- Above -7°C ...Summer type diesel fuel.
- Below -7°C ...Winter type diesel fuel.

CAUTION:

- **Do not use home heating oil, gasoline or other alternate fuels in your diesel engine. The use of those can cause engine damage.**
- **Do not use summer fuel at temperatures below -7°C (20°F). The cold temperatures will cause wax to form in the fuel. As a result, it may prevent the engine from running smoothly.**
- **Do not add gasoline or other alternate fuels to diesel fuel.**

LIFTING POINT

< PRECAUTION >

LIFTING POINT

Commercial Service Tools

INFOID:000000001178896

GI

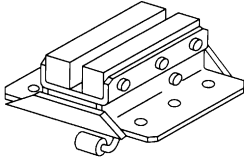
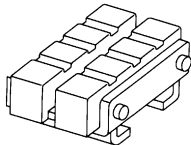
Tool name	Description
Board on attachment	 <p style="text-align: right;">S-NT001</p>
Safety stand attachment	 <p style="text-align: right;">S-NT002</p>

B

C

D

E

F

G

CAUTION:

- Every time the vehicle is lifted up, maintain the complete vehicle curb condition.
- Since the vehicle's center of gravity changes when removing main parts on the front side (engine, transmission, suspension etc.), support a jack up point on the rear side garage jack with a mission jack or equivalent.
- Since the vehicle's center of gravity changes when removing main parts on the rear side (rear axle, suspension, etc.), support a jack up point on the front side garage jack with a mission jack or equivalent.
- Be careful not to smash or do not do anything that would affect piping parts.

H

I

J

Garage Jack and Safety Stand and 2-Pole Lift

INFOID:000000001178897

WARNING:

- Park the vehicle on a level surface when using the jack. Make sure to avoid damaging pipes, tubes, etc. under the vehicle.
- Never get under the vehicle while it is supported only by the jack. Always use safety stands when you have to get under the vehicle.
- Place wheel chocks at both front and back of the wheels on the ground.
- When lifting the vehicle, open the lift arms as wide as possible and ensure that the front and rear of the vehicle are well balanced.
- When setting the lift arm, do not allow the arm to contact the brake tubes, brake cable, fuel lines and sill spoiler.

K

L

M

N

O

P

LIFTING POINT

< PRECAUTION >

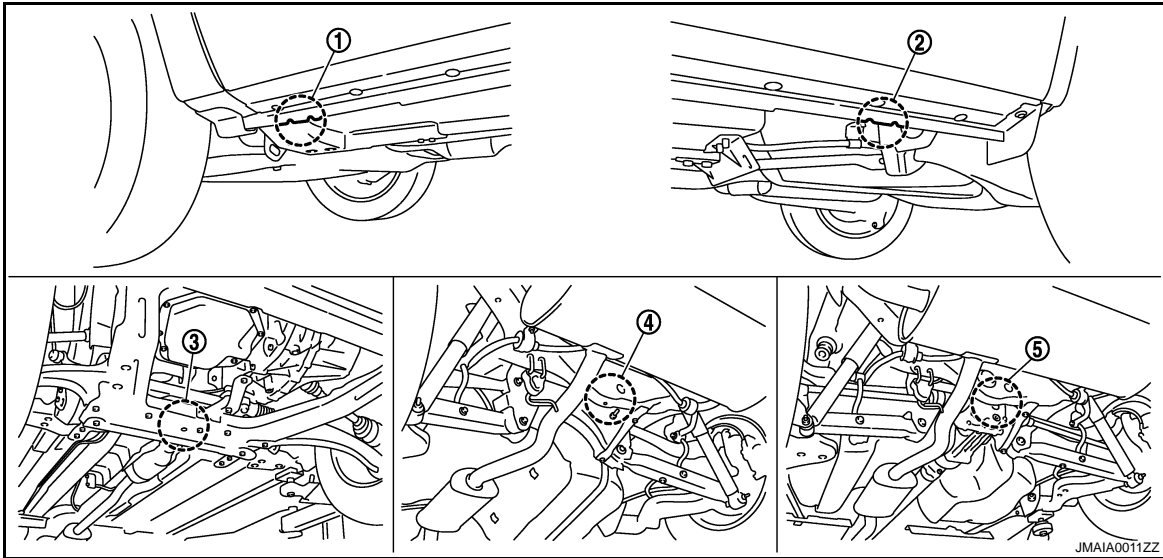

1. Safety stand point and lift up point (front)
2. Safety stand point and lift up point (rear)
3. Garage jack point (front)
4. Garage jack point (rear) (2WD)
5. Garage jack point (rear) (4WD)

CAUTION:

There is canister just behind Garage jack point rear. Jack up be carefully.

Board-On Lift

INFOID:000000001178898

CAUTION:

Make sure vehicle is empty when lifting.

- The board-on lift attachment (A) set at front end of vehicle should be set on the front of the sill under the front door opening.
- Position attachments at front and rear ends of board-on lift.

← : Vehicle front

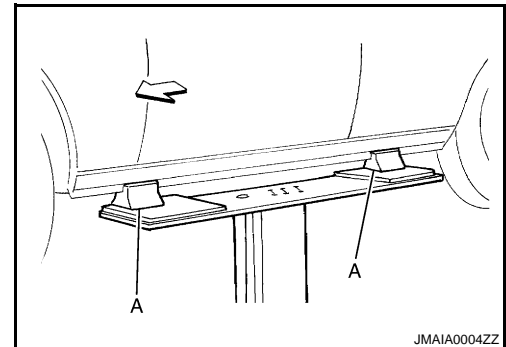

TOW TRUCK TOWING

< PRECAUTION >

TOW TRUCK TOWING

Tow Truck Towing

INFOID:000000001178899

GI

CAUTION:

- All applicable local laws regarding the towing operation must be obeyed.
- It is necessary to use proper towing equipment to avoid possible damage to the vehicle during towing operation. Towing is in accordance with Towing Procedure Manual at dealer.
- Always attach safety chains before towing.
- When towing, make sure that the transmission, steering system and powertrain are in good order. If any unit is damaged, dollies must be used.
- Never tow an automatic transmission model and CVT model from the rear (that is backward) with four wheels on the ground. This may cause serious and expensive damage to the transmission.

2WD MODELS

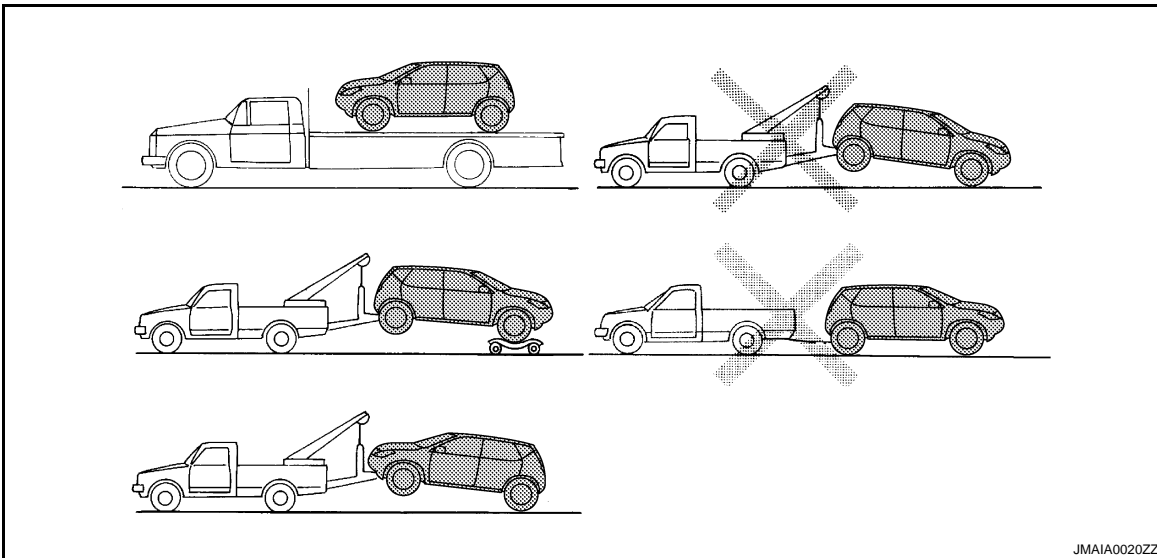

NISSAN recommends that vehicle be towed with the driving (front) wheels off the ground or that a dolly be used as illustrated.

CAUTION:

- Never tow automatic transmission model and CVT models with the front wheels on the ground or four wheels on the ground (forward or backward), as this may cause serious and expensive damage to the transmission.
If it is necessary to tow the vehicle with the rear wheels raised, always use towing dollies under the front wheels.
- When towing automatic transmission model and CVT models with the front wheels on towing dollies:
 - Turn the ignition key to the OFF position, and secure the steering wheel in a straight ahead position with a rope or similar device. Never secure the steering wheel by turning the ignition key to the LOCK position. This may damage the steering lock mechanism.
 - Move the selector lever to the N (Neutral) position.
- When towing two wheel drive automatic transmission model and CVT model with the rear wheels on the ground (if you do not use towing dollies): Always release the parking brake.

TOW TRUCK TOWING

< PRECAUTION >

4WD MODELS

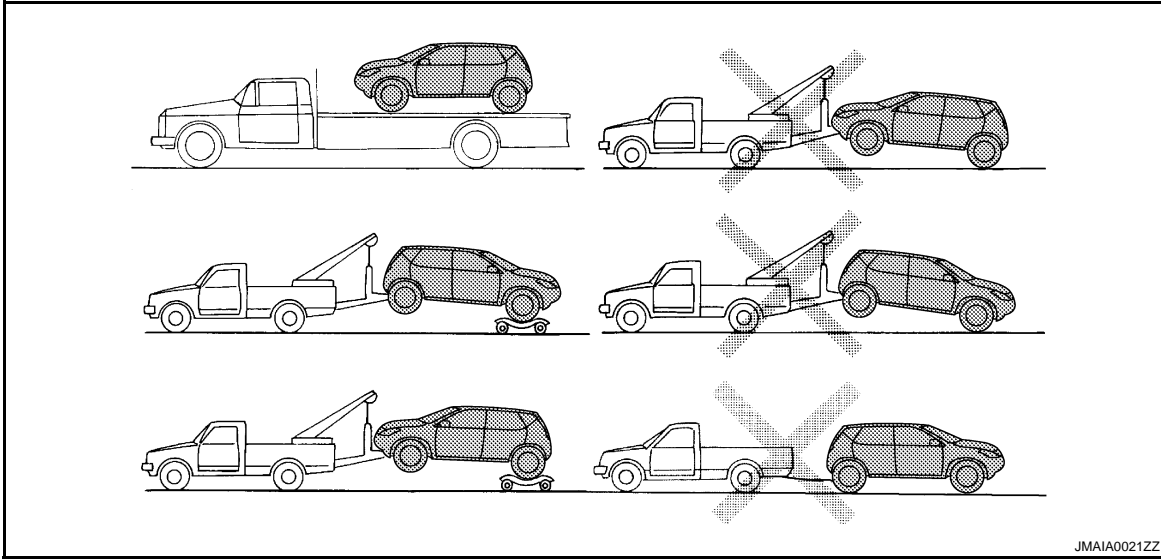

NISSAN recommends that a dolly be used as illustrated when towing 4WD models.

CAUTION:

Never tow 4WD models with any of the wheels on the ground as this may cause serious and expensive damage to the drive train.

Vehicle Recovery (Freeing a Stuck Vehicle)

INFOID:000000001178900

FRONT

1. Remove the hook cover from the bumper using a remover tool.
2. Securely install the vehicle recovery hook stored with jacking tools.

Make sure that the hook is properly secured in the stored place after use.

WARNING:

- Stand clear of a stuck vehicle.
- Do not spin your tires at high speed. This could cause them to explode and result in serious injury. Parts of your vehicle could also overheat and be damaged.

CAUTION:

- Tow chains or cables must be attached only to the vehicle recovery hooks or main structural members of the vehicle. Otherwise, the vehicle body will be damaged.
- Do not use the vehicle tie downs to free a vehicle stuck in sand, snow, mud, etc. Never tow the vehicle using the vehicle tie downs or recovery hooks.
- Always pull the cable straight out from the front of the vehicle. Never pull on the hook at an angle.
- Pulling devices should be routed so they do not touch any part of the suspension, steering, brake or cooling systems.
- Pulling devices such as ropes or canvas straps are not recommended for use in vehicle towing or recovery.

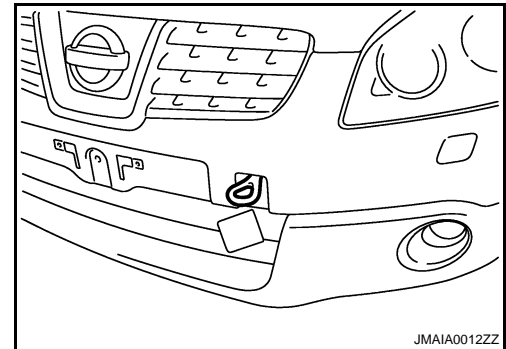

REAR

TOW TRUCK TOWING

< PRECAUTION >

1. Remove the towing hook cover from the bumper.
2. Securely install the towing hook stored with jacking tools.

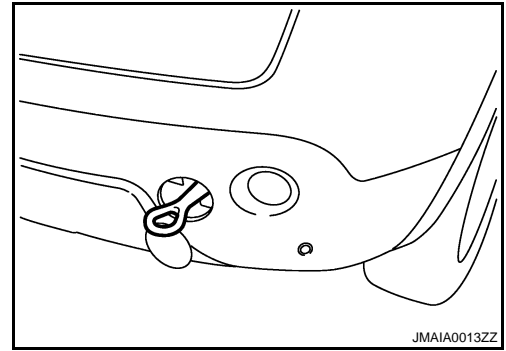

GI

B

C

D

E

F

G

H

I

J

K

L

M

N

O

P

SERVICE INFORMATION FOR ELECTRICAL INCIDENT

< BASIC INSPECTION >

BASIC INSPECTION

SERVICE INFORMATION FOR ELECTRICAL INCIDENT

Work Flow

INFOID:000000001178901

WORK FLOW

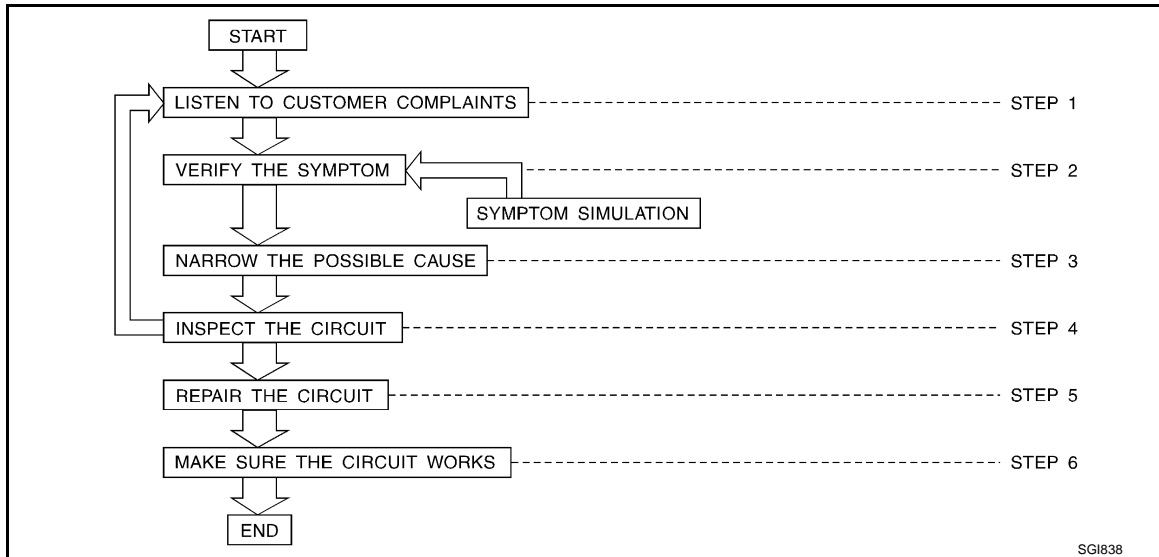

SGI838

STEP	DESCRIPTION	
STEP 1	Get detailed information about the conditions and the environment when the incident occurred. The following are key pieces of information required to make a good analysis:	
	WHAT	Vehicle Model, Engine, Transmission/Transaxle and the System (i.e. Radio).
	WHEN	Date, Time of Day, Weather Conditions, Frequency.
	WHERE	Road Conditions, Altitude and Traffic Situation.
STEP 2	HOW	System Symptoms, Operating Conditions (Other Components Interaction). Service History and if any After Market Accessories have been installed.
	Operate the system, road test if necessary. Verify the parameter of the incident. If the problem cannot be duplicated, refer to "Incident Simulation Tests".	
STEP 3	Get the proper diagnosis materials together including: <ul style="list-style-type: none"> • Power Supply Routing • System Operation Descriptions • Applicable Service Manual Sections • Check for any Service Bulletins Identify where to begin diagnosis based upon your knowledge of the system operation and the customer comments.	
STEP 4	Inspect the system for mechanical binding, loose connectors or wiring damage. Determine which circuits and components are involved and diagnose using the Power Supply Routing and Harness Layouts.	
STEP 5	Repair or replace the incident circuit or component.	
STEP 6	Operate the system in all modes. Verify the system works properly under all conditions. Make sure you have not inadvertently created a new incident during your diagnosis or repair steps.	

Control Units and Electrical Parts

INFOID:000000001178902

PRECAUTIONS

- Never reverse polarity of battery terminals.
- Install only parts specified for a vehicle.
- Before replacing the control unit, check the input and output and functions of the component parts.
- Do not apply excessive force when disconnecting a connector.

SERVICE INFORMATION FOR ELECTRICAL INCIDENT

< BASIC INSPECTION >

- Do not apply excessive shock to the control unit by dropping or hitting it.
- Be careful to prevent condensation in the control unit due to rapid temperature changes and do not let water or rain get on it. If water is found in the control unit, dry it fully and then install it in the vehicle.
- Be careful not to let oil get on the control unit connector.
- Avoid cleaning the control unit with volatile oil.
- Do not disassemble the control unit, and do not remove the upper and lower covers.

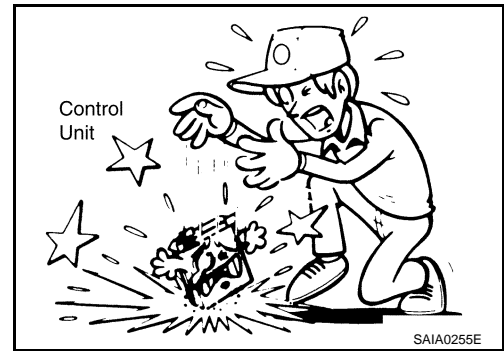

- When using a DMM, be careful not to let test probes get close to each other to prevent the power transistor in the control unit from damaging battery voltage because of short circuiting.
- When checking input and output signals of the control unit, use the specified check adapter.

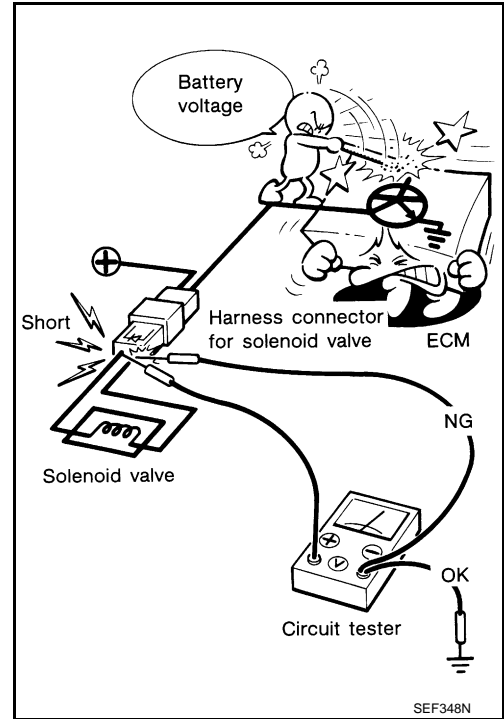

Intermittent Incident

INFOID:000000001178903

DESCRIPTION

Sometimes the symptom is not present when the vehicle is brought in for service. If possible, re-create the conditions present at the time of the incident. Doing so may help avoid a No Trouble Found Diagnosis. The following section illustrates ways to simulate the conditions/environment under which the owner experiences an electrical incident.

The section is broken into the six following topics:

- Vehicle vibration
- Heat sensitive
- Freezing
- Water intrusion
- Electrical load
- Cold or hot start up

Get a thorough description of the incident from the customer. It is important for simulating the conditions of the problem.

VEHICLE VIBRATION

The problem may occur or become worse while driving on a rough road or when engine is vibrating (idle with A/C on). In such a case, you will want to check for a vibration related condition. Refer to the following illustration.

Connector & Harness

SERVICE INFORMATION FOR ELECTRICAL INCIDENT

< BASIC INSPECTION >

Determine which connectors and wiring harness would affect the electrical system you are inspecting. Gently shake each connector and harness while monitoring the system for the incident you are trying to duplicate. This test may indicate a loose or poor electrical connection.

Hint

Connectors can be exposed to moisture. It is possible to get a thin film of corrosion on the connector terminals. A visual inspection may not reveal this without disconnecting the connector. If the problem occurs intermittently, perhaps the problem is caused by corrosion. It is a good idea to disconnect, inspect and clean the terminals on related connectors in the system.

Sensor & Relay

Gently apply a slight vibration to sensors and relays in the system you are inspecting. This test may indicate a loose or poorly mounted sensor or relay.

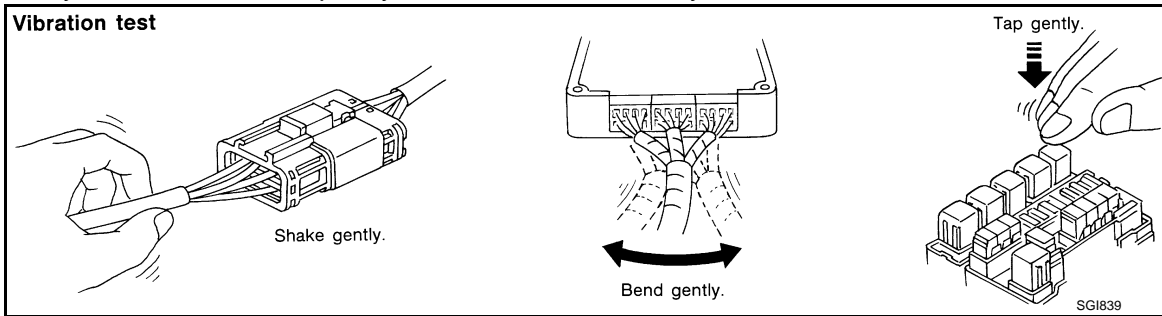

Engine Compartment

There are several reasons a vehicle or engine vibration could cause an electrical complaint. Some of the things to check for are:

- Connectors not fully seated.
- Wiring harness not long enough and is being stressed due to engine vibrations or rocking.
- Wires laying across brackets or moving components.
- Loose, dirty or corroded ground wires.
- Wires routed too close to hot components.

To inspect components under the hood, start by verifying the integrity of ground connections. (Refer to Ground Inspection described later.) First check that the system is properly grounded. Then check for loose connection by gently shaking the wiring or components as previously explained. Using the wiring diagrams inspect the wiring for continuity.

Behind the Instrument Panel

An improperly routed or improperly clamped harness can become pinched during accessory installation. Vehicle vibration can aggravate a harness which is routed along a bracket or near a screw.

Under Seating Areas

An unclamped or loose harness can cause wiring to be pinched by seat components (such as slide guides) during vehicle vibration. If the wiring runs under seating areas, inspect wire routing for possible damage or pinching.

HEAT SENSITIVE

- The customer's concern may occur during hot weather or after car has sat for a short time. In such cases you will want to check for a heat sensitive condition.
- To determine if an electrical component is heat sensitive, heat the component with a heat gun or equivalent.

CAUTION:

Do not heat components above 60°C (140°).

- If incident occurs while heating the unit, either replace or properly insulate the component.

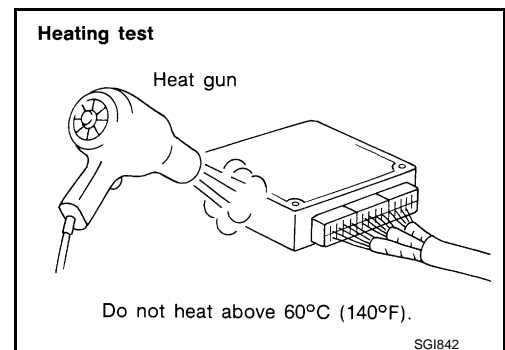

FREEZING

SERVICE INFORMATION FOR ELECTRICAL INCIDENT

< BASIC INSPECTION >

- The customer may indicate the incident goes away after the car warms up (winter time). The cause could be related to water freezing somewhere in the wiring/electrical system.
- There are two methods to check for this. The first is to arrange for the owner to leave his car overnight. Make sure it will get cold enough to demonstrate his complaint. Leave the car parked outside overnight. In the morning, do a quick and thorough diagnosis of those electrical components which could be affected.
- The second method is to put the suspect component into a freezer long enough for any water to freeze. Reinstall the part into the car and check for the reoccurrence of the incident. If it occurs, repair or replace the component.

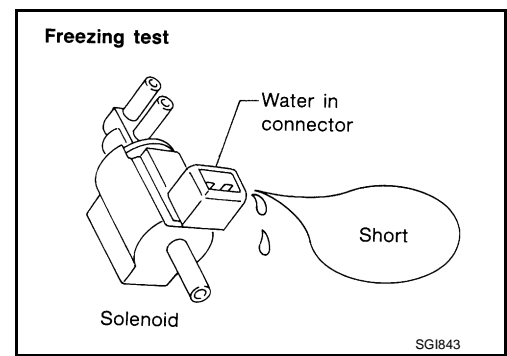

WATER INTRUSION

The incident may occur only during high humidity or in rainy/snowy weather. In such cases the incident could be caused by water intrusion on an electrical part. This can be simulated by soaking the car or running it through a car wash.

CAUTION:

Do not spray water directly on any electrical components.

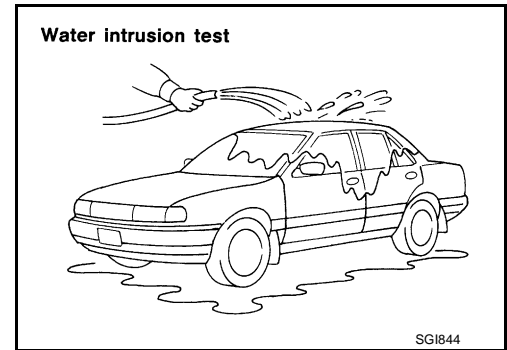

ELECTRICAL LOAD

The incident may be electrical load sensitive. Perform diagnosis with all accessories (including A/C, rear window defogger, radio, fog lamps) turned on.

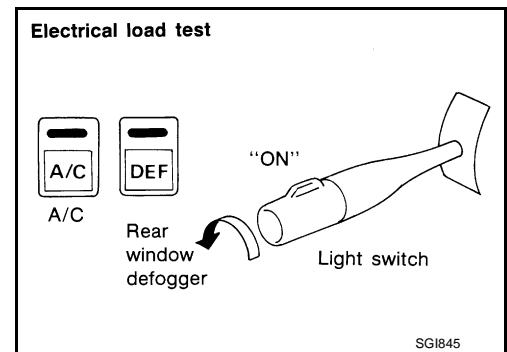

COLD OR HOT START UP

On some occasions an electrical incident may occur only when the car is started cold, or it may occur when the car is restarted hot shortly after being turned off. In these cases you may have to keep the car overnight to make a proper diagnosis.

Circuit Inspection

INFOID:000000001178904

DESCRIPTION

- In general, testing electrical circuits is an easy task if it is approached in a logical and organized method. Before beginning it is important to have all available information on the system to be tested. Also, get a thorough understanding of system operation. Then you will be able to use the appropriate equipment and follow the correct test procedure.
- You may have to simulate vehicle vibrations while testing electrical components. Gently shake the wiring harness or electrical component to do this.

OPEN	A circuit is open when there is no continuity through a section of the circuit.	
SHORT	There are two types of shorts.	
	• SHORT CIRCUIT	When a circuit contacts another circuit and causes the normal resistance to change.
	• SHORT TO GROUND	When a circuit contacts a ground source and grounds the circuit.

GI
B
C
D
E
F
G
H
I
J
K
L
M
N
O
P

SERVICE INFORMATION FOR ELECTRICAL INCIDENT

< BASIC INSPECTION >

TESTING FOR "OPENS" IN THE CIRCUIT

Before you begin to diagnose and test the system, you should rough sketch a schematic of the system. This will help you to logically walk through the diagnosis process. Drawing the sketch will also reinforce your working knowledge of the system.

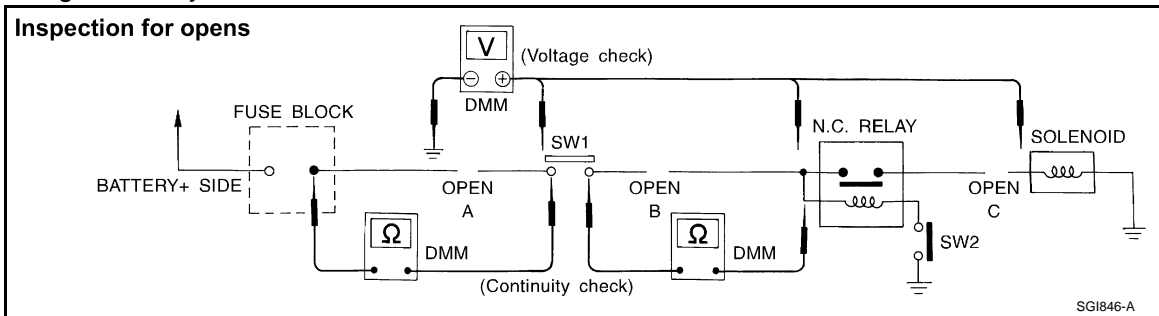

Continuity Check Method

The continuity check is used to find an open in the circuit. The digital multimeter (DMM) set on the resistance function will indicate an open circuit as over limit (no beep tone or no ohms symbol). Make sure to always start with the DMM at the highest resistance level.

To help in understanding the diagnosis of open circuits, please refer to the previous schematic.

- Disconnect the battery negative cable.
- Start at one end of the circuit and work your way to the other end. (At the fuse block in this example)
- Connect one probe of the DMM to the fuse block terminal on the load side.
- Connect the other probe to the fuse block (power) side of SW1. Little or no resistance will indicate that portion of the circuit has good continuity. If there were an open in the circuit, the DMM would indicate an over limit or infinite resistance condition. (point A)
- Connect the probes between SW1 and the relay. Little or no resistance will indicate that portion of the circuit has good continuity. If there were an open in the circuit, the DMM would indicate an over limit or infinite resistance condition. (point B)
- Connect the probes between the relay and the solenoid. Little or no resistance will indicate that portion of the circuit has good continuity. If there were an open in the circuit, the DMM would indicate an over limit or infinite resistance condition. (point C)

Any circuit can be diagnosed using the approach in the previous example.

Voltage Check Method

To help in understanding the diagnosis of open circuits please refer to the previous schematic.

In any powered circuit, an open can be found by methodically checking the system for the presence of voltage. This is done by switching the DMM to the voltage function.

- Connect one probe of the DMM to a known good ground.
- Begin probing at one end of the circuit and work your way to the other end.
- With SW1 open, probe at SW1 to check for voltage.
voltage; open is further down the circuit than SW1.
no voltage; open is between fuse block and SW1 (point A).
- Close SW1 and probe at relay.
voltage; open is further down the circuit than the relay.
no voltage; open is between SW1 and relay (point B).
- Close the relay and probe at the solenoid.
voltage; open is further down the circuit than the solenoid.
no voltage; open is between relay and solenoid (point C).

Any powered circuit can be diagnosed using the approach in the previous example.

TESTING FOR "SHORTS" IN THE CIRCUIT

SERVICE INFORMATION FOR ELECTRICAL INCIDENT

< BASIC INSPECTION >

To simplify the discussion of shorts in the system, please refer to the following schematic.

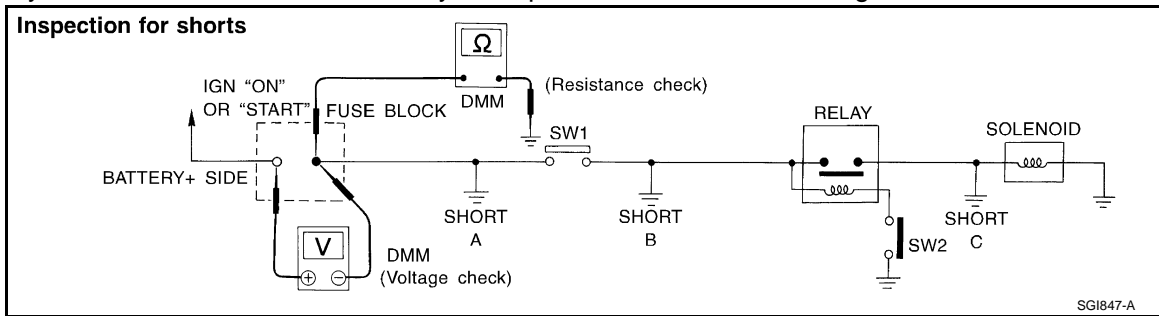

Resistance Check Method

- Disconnect the battery negative cable and remove the blown fuse.
- Disconnect all loads (SW1 open, relay disconnected and solenoid disconnected) powered through the fuse.
- Connect one probe of the DMM to the load side of the fuse terminal. Connect the other probe to a known good ground.
- With SW1 open, check for continuity.
continuity; short is between fuse terminal and SW1 (point A).
no continuity; short is further down the circuit than SW1.
- Close SW1 and disconnect the relay. Put probes at the load side of fuse terminal and a known good ground. Then, check for continuity.
continuity; short is between SW1 and the relay (point B).
no continuity; short is further down the circuit than the relay.
- Close SW1 and jump the relay contacts with jumper wire. Put probes at the load side of fuse terminal and a known good ground. Then, check for continuity.
continuity; short is between relay and solenoid (point C).
no continuity; check solenoid, retrace steps.

Voltage Check Method

- Remove the blown fuse and disconnect all loads (i.e. SW1 open, relay disconnected and solenoid disconnected) powered through the fuse.
- Turn the ignition key to the ON or START position. Verify battery voltage at the battery + side of the fuse terminal (one lead on the battery + terminal side of the fuse block and one lead on a known good ground).
- With SW1 open and the DMM leads across both fuse terminals, check for voltage.
voltage; short is between fuse block and SW1 (point A).
no voltage; short is further down the circuit than SW1.
- With SW1 closed, relay and solenoid disconnected and the DMM leads across both fuse terminals, check for voltage.
voltage; short is between SW1 and the relay (point B).
no voltage; short is further down the circuit than the relay.
- With SW1 closed, relay contacts jumped with fused jumper wire check for voltage.
voltage; short is down the circuit of the relay or between the relay and the disconnected solenoid (point C).
no voltage; retrace steps and check power to fuse block.

GROUND INSPECTION

- Ground connections are very important to the proper operation of electrical and electronic circuits. Ground connections are often exposed to moisture, dirt and other corrosive elements. The corrosion (rust) can become an unwanted resistance. This unwanted resistance can change the way a circuit works.
- Electronically controlled circuits are very sensitive to proper grounding. A loose or corroded ground can drastically affect an electronically controlled circuit. A poor or corroded ground can easily affect the circuit. Even when the ground connection looks clean, there can be a thin film of rust on the surface.
- When inspecting a ground connection follow these rules:
 - Remove the ground bolt or screw.
 - Inspect all mating surfaces for tarnish, dirt, rust, etc.
 - Clean as required to assure good contact.
 - Reinstall bolt or screw securely.
 - Inspect for "add-on" accessories which may be interfering with the ground circuit.
 - If several wires are crimped into one ground eyelet terminal, check for proper crimps. Make sure all of the wires are clean, securely fastened and providing a good ground path. If multiple wires are cased in one eyelet make sure no ground wires have excess wire insulation.

SERVICE INFORMATION FOR ELECTRICAL INCIDENT

< BASIC INSPECTION >

- For detailed ground distribution information, refer to “Ground Distribution” in PG section.

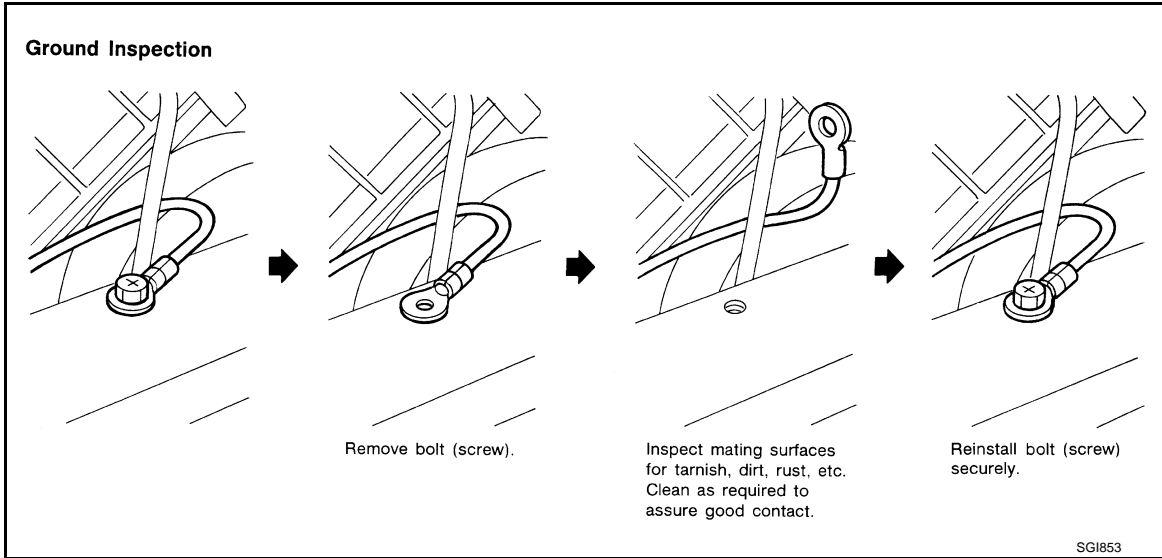

VOLTAGE DROP TESTS

- Voltage drop tests are often used to find components or circuits which have excessive resistance. A voltage drop in a circuit is caused by a resistance when the circuit is in operation.
- Check the wire in the illustration. When measuring resistance with DMM, contact by a single strand of wire will give reading of 0 ohms. This would indicate a good circuit. When the circuit operates, this single strand of wire is not able to carry the current. The single strand will have a high resistance to the current. This will be picked up as a slight voltage drop.
- Unwanted resistance can be caused by many situations as follows:
 - Undersized wiring (single strand example)
 - Corrosion on switch contacts
 - Loose wire connections or splices.
- If repairs are needed always use wire that is of the same or larger gauge.

Measuring Voltage Drop — Accumulated Method

- Connect the DMM across the connector or part of the circuit you want to check. The positive lead of the DMM should be closer to power and the negative lead closer to ground.
- Operate the circuit.
- The DMM will indicate how many volts are being used to “push” current through that part of the circuit.

Note in the illustration that there is an excessive 4.1 volt drop between the battery and the bulb.

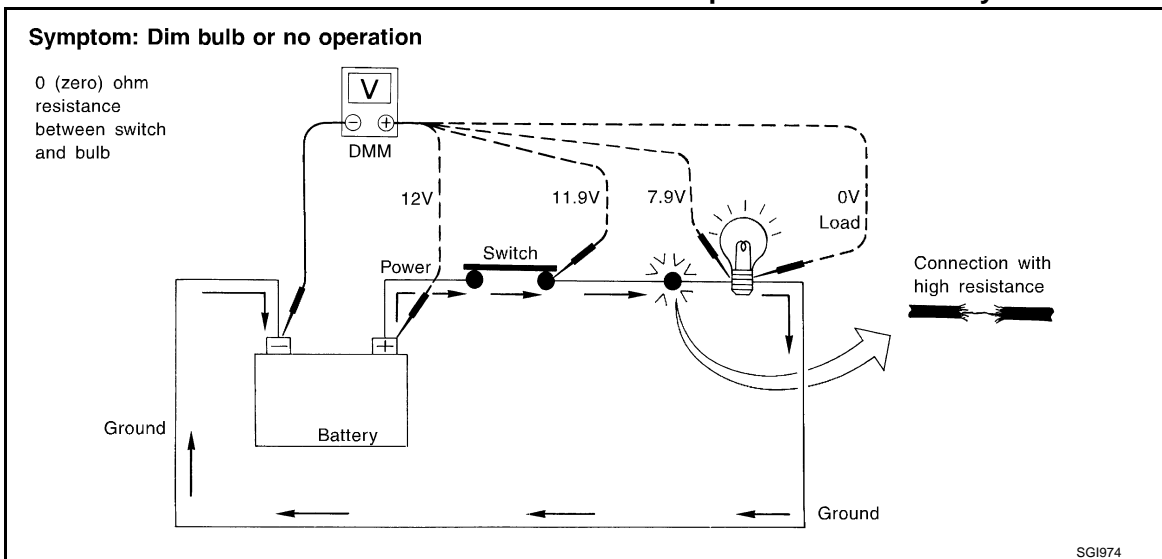

Measuring Voltage Drop — Step-by-Step

- The step-by-step method is most useful for isolating excessive drops in low voltage systems (such as those in “Computer Controlled Systems”).
- Circuits in the “Computer Controlled System” operate on very low amperage.

SERVICE INFORMATION FOR ELECTRICAL INCIDENT

< BASIC INSPECTION >

- The (Computer Controlled) system operations can be adversely affected by any variation in resistance in the system. Such resistance variation may be caused by poor connection, improper installation, improper wire gauge or corrosion.
- The step by step voltage drop test can identify a component or wire with too much resistance.

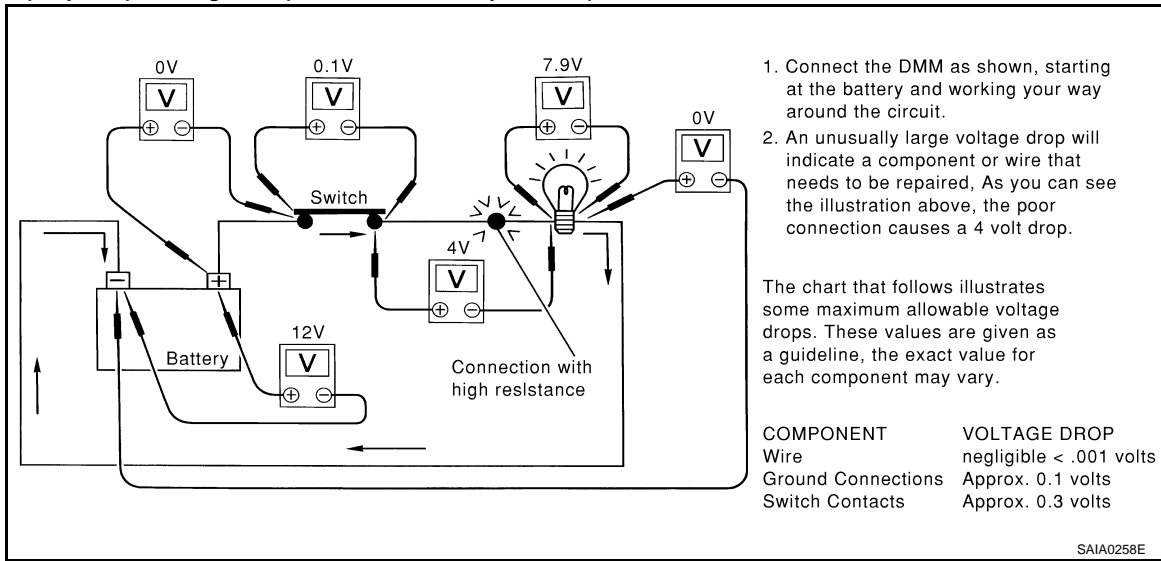

CONTROL UNIT CIRCUIT TEST

System Description

- When the switch is ON, the control unit lights up the lamp.

CASE 1

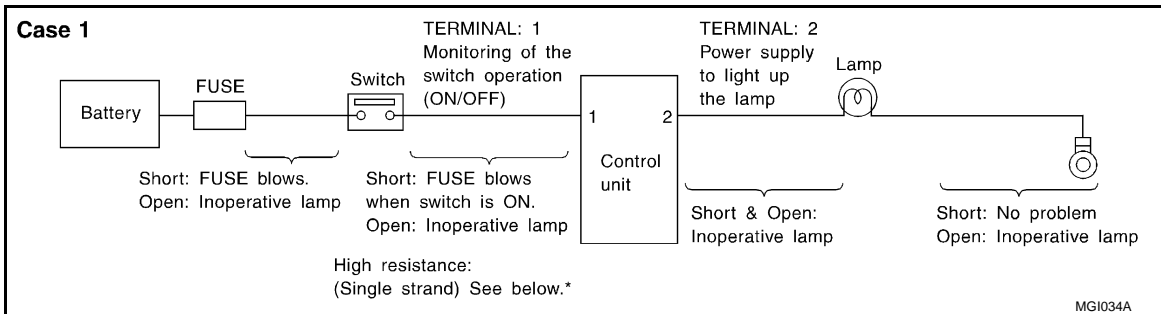

INPUT-OUTPUT VOLTAGE CHART

Terminal No.		Description		Condition	Value (Approx.)	In case of high resistance such as single strand (V) *
+	-	Signal name	Input/ Output			
1	Body ground	Switch	Input	Switch ON	Battery voltage	Lower than battery voltage Approx. 8 (Example)
				Switch OFF	0 V	Approx. 0
2	Body ground	Lamp	Output	Switch ON	Battery voltage	Approx. 0 (Inoperative lamp)
				Switch OFF	0 V	Approx. 0

- The voltage value is based on the body ground.
- *: If high resistance exists in the switch side circuit (caused by a single strand), terminal 1 does not detect battery voltage. Control unit does not detect the switch is ON even if the switch does not turn ON. Therefore, the control unit does not supply power to light up the lamp.

SERVICE INFORMATION FOR ELECTRICAL INCIDENT

< BASIC INSPECTION >

CASE 2

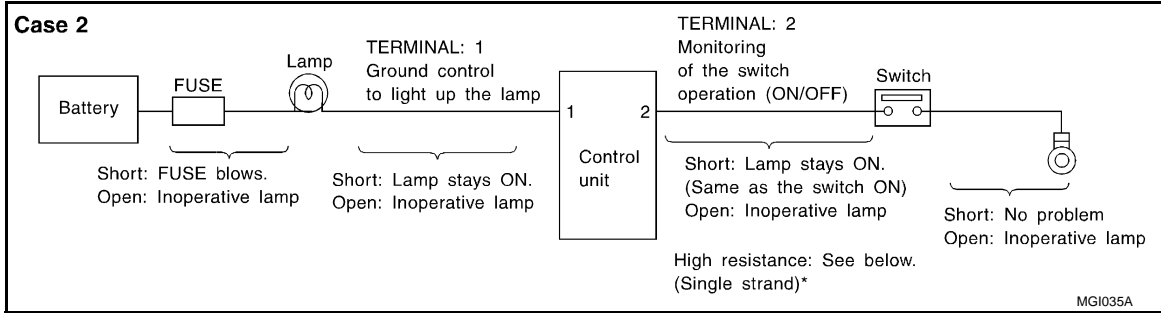

INPUT-OUTPUT VOLTAGE CHART

Terminal No.		Description		Condition	Value (Approx.)	In case of high resistance such as single strand (V) *
+	-	Signal name	Input/Output			
1	Body ground	Lamp	Output	Switch ON	0V	Battery voltage (Inoperative lamp)
				Switch OFF	Battery voltage	Battery voltage
2	Body ground	Switch	Input	Switch ON	0 V	Higher than 0 Approx. 4 (Example)
				Switch OFF	5 V	Approx. 5

- The voltage value is based on the body ground.
- *: If high resistance exists in the switch side circuit (caused by a single strand), terminal 2 does not detect approx. 0V. Control unit does not detect the switch is ON even if the switch does not turn ON. Therefore, the control unit does not control ground to light up the lamp.

CONSULT-III/GST CHECKING SYSTEM

< BASIC INSPECTION >

CONSULT-III/GST CHECKING SYSTEM

GI

Description

INFOID:000000001178905

- When CONSULT-III/GST is connected with a data link connector (A) equipped on the vehicle side, it will communicate with the control unit equipped in the vehicle and then enable various kinds of diagnostic tests.

1 : Instrument driver lower panel

- Refer to CONSULT-III Operation Manual for more information.

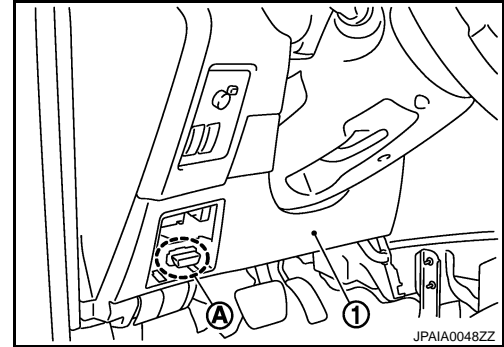

CONSULT-III Function and System Application*2

INFOID:000000001178906

Diagnostic test mode	Function	ENGINE	TRANSMISSION	AIR BAG	METER/M&A	BCM	ABS	ABS (Including ESP)	IPDM E/R	ALL MODE AWD/4WD	HEAD LAMP LEVELIZER	MULTI AV	REAR VIEW CAMERA	EPS	INTELLIGENT KEY
Work support	This mode enables a technician to adjust some devices faster and more accurately by following the indications on CONSULT-III.	x	x*1	-	-	x	-	x	-	-	x	-	x	-	x
Self-diagnostic results	Self-diagnostic results can be read and erased quickly.	x	x	x	x	x	x	x	x	x	x	x	-	x	x
Trouble diagnostic record	Current self-diagnostic results and all trouble diagnostic records previously stored can be read.	-	-	x	-	-	-	-	-	-	-	-	-	-	-
Data monitor	Input/Output data in the ECU can be read.	x	x	-	x	x	x	x	x	x	x	x	x	x	x
CAN diagnosis	The condition of CAN communication line can be indicated by a topology.	x	x	-	x	x	x	x	x	x	-	x	-	x	x
CAN diagnosis support monitor	The condition of CAN communication line can be read.	x	x	-	x	x	x	x	x	x	-	x	-	x	x
Active test	Diagnostic Test Mode in which CONSULT-III drives some actuators apart from the ECUs and also shifts some parameters in a specified range.	x	-	-	-	x	x	x	x	x	x	-	-	-	x
DTC & SRT confirmation	The results of SRT (System Readiness Test) and the self-diagnosis status/result can be confirmed.	x*1	-	-	-	-	-	-	-	-	-	-	-	-	-
DTC work support	This mode enables a technician to monitor the status/results of self-diagnosis performed by the ECU.	-	-	-	-	-	-	-	-	-	-	-	-	-	-
ECU (ECM/TCM) part number	ECU (ECM/TCM) part number can be read.	x	x	-	-	x	x	x	x	x	-	x	x	x	x
ECU discriminated No.	Classification number of a replacement ECU can be read to prevent an incorrect ECU from being installed.	-	-	x	-	-	-	-	-	-	x	-	-	-	-

B
C
D
E
F
G
H
I
J
K
L
M
N
O
P

CONSULT-III/GST CHECKING SYSTEM

< BASIC INSPECTION >

Diagnostic test mode	Function	ENGINE	TRANSMISSION	AIR BAG	METER/M&A	BCM	ABS	ABS (Including ESP)	IPDM E/R	ALL MODE AWD/4WD	HEAD LAMP LEVELIZER	MULTI AV	REAR VIEW CAMERA	EPS	INTELLIGENT KEY
Function test	This mode can show results of self-diagnosis of ECU with either 'OK' or 'NG'. For engines, more practical tests regarding sensors/ switches and/or actuators are available.	x*1	x*1	x	-	-	x	x	-	-	-	-	-	-	-
Configuration	Function to READ/WRITE vehicle configuration.	-	-	-	-	x	-	-	-	-	x	-	-	-	-
AV COMM monitor	The condition of AV communication can be indicated.	-	-	-	-	-	-	-	-	-	-	x	-	-	-
CALIB data	Characteristic information for TCM and CVT assembly can be read.	-	x*1	-	-	-	-	-	-	-	-	-	-	-	-

x: Applicable

*1 : Petrol engine models

*2 : If GST application is equipped, functions in accordance with SAE J1979 and ISO 15031-5 can be used.

CONSULT-III/GST Data Link Connector (DLC) Circuit

INFOID:000000001178907

INSPECTION PROCEDURE

If the CONSULT-III/GST cannot diagnose the system properly, check the following items.

Symptom	Check item
CONSULT-III/GST cannot access any system.	<ul style="list-style-type: none"> CONSULT-III DLC power supply circuit (Terminal 8 and 16) and ground circuit (Terminal 4 and 5)
CONSULT-III cannot access individual system. (Other systems can be accessed.)	<ul style="list-style-type: none"> Power supply and ground circuit for the control unit of the system (For detailed circuit, refer to wiring diagram for each system.) Open or short circuit between the system and CONSULT-III DLC (For detailed circuit, refer to wiring diagram for each system.) Open or short circuit CAN communication line. Refer to LAN-13, "Trouble Diagnosis Flow Chart".

NOTE:

The DDL1 and DDL2 circuits from DLC pins 12, 13, 14 and 15 may be connected to more than one system. A short in a DDL circuit connected to a control unit in one system may affect CONSULT-III access to other systems.

If the GST cannot operate properly, check the circuit based on the information of SAE J1962 and ISO 15031-3.

CONSULT-III/GST CHECKING SYSTEM

< BASIC INSPECTION >

Wiring Diagram - CONSULT-III/GST CHECKING SYSTEM -

INFOID:000000001178908

CONSULT-III CHECKING SYSTEM

- : CAN communication line for diagnosis
- : DDL2 communication line
- ◊4W◊ : 4WD models
- ◊ES◊ : With ESP
- ◊OE◊ : Without ESP
- ◊NV◊ : With navigation system
- ◊IK◊ : With Intelligent Key
- ◊HA◊ : With headlamp auto aiming
- ◊RC◊ : With rear view camera
- *1 88◊ ◊G◊
- 104◊ ◊M9◊
- ◊G◊ : With gasoline engine
- ◊D◊ : With diesel engine
- ◊K9◊ : With K9K engine
- ◊M9◊ : With M9R engine
- ◊XK◊ : Except K9K engine
- ◊A◊ : With A/T
- ◊C◊ : With CVT
- ◊NM◊ : Except M/T

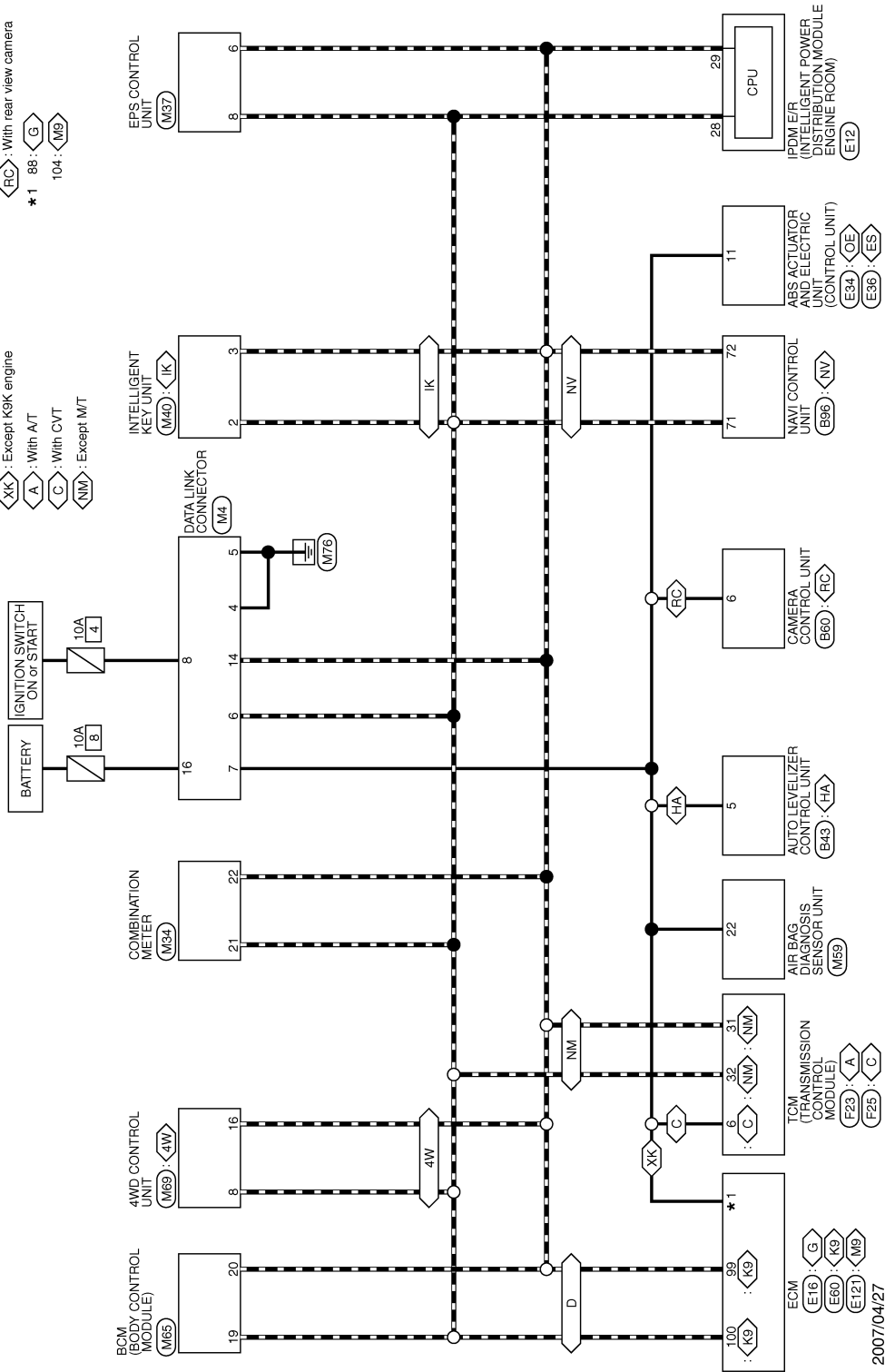

2007/04/27

JCAWA0026GE

GI



B
C
D
E
F
G
H
I
J
K
L
M
N
O
P

CONSULT-III/GST CHECKING SYSTEM

< BASIC INSPECTION >



CONSULT-III CHECKING SYSTEM

Connector No.	E16
Connector Name	ECM
Connector Type	MAA2/FB-MEA8-LH



Terminal No.	Color of Wire	Signal Name [Specification]
5	O	K-LINE

Connector No.	E12
Connector Name	IPDM E/R (INTELLIGENT POWER DISTRIBUTION MODULE ENGINE ROOM)
Connector Type	NS12/FW-CS

Terminal No.	Color of Wire	Signal Name [Specification]
28	L	-
29	P	-

Connector No.	E38
Connector Name	ABS ACTUATOR AND ELECTRIC UNIT (CONTROL UNIT)
Connector Type	BAA2/FB-AHZA-LH

Terminal No.	Color of Wire	Signal Name [Specification]
71	L	CAN-H
72	P	CAN-L

Connector No.	E36
Connector Name	ABS ACTUATOR AND ELECTRIC UNIT (CONTROL UNIT)
Connector Type	BAA2/FB-AHZA-LH

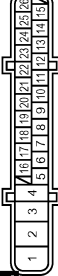

Terminal No.	Color of Wire	Signal Name [Specification]
11	O	DIAG-K

Connector No.	E16
Connector Name	ECM
Connector Type	MAA2/FB-MEA8-LH

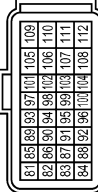
Terminal No.	Color of Wire	Signal Name [Specification]
88	O	K-LINE

Connector No.	E34
Connector Name	ABS ACTUATOR AND ELECTRIC UNIT (CONTROL UNIT)
Connector Type	BAA2/FB-AHZA-LH



Terminal No.	Color of Wire	Signal Name [Specification]
11	O	DIAG-K

Connector No.	E60
Connector Name	ECM
Connector Type	MAA2/FB-MEA8-LH

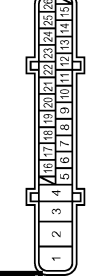
Terminal No.	Color of Wire	Signal Name [Specification]
89	P	MAIN CAN-L (BODY)
100	L	MAIN CAN-H (BODY)

Connector No.	B96
Connector Name	NAVI CONTROL UNIT
Connector Type	TH32/FW

Terminal No.	Color of Wire	Signal Name [Specification]
71	L	CAN-H
72	P	CAN-L

CONSULT-III/GST CHECKING SYSTEM

< BASIC INSPECTION >

CONSULT-III CHECKING SYSTEM

Connector No.	E121
Connector Name	ECM
Connector Type	MAA24FB-MEA8-LH

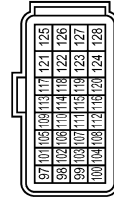

Terminal No.	Color of Wire	Signal Name [Specification]
104	O	K-LINE

Connector No.	F23
Connector Name	TCM (TRANSMISSION CONTROL MODULE)
Connector Type	MOLEX 500934-4111

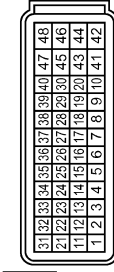

Terminal No.	Color of Wire	Signal Name [Specification]
31	P	CAN-L
32	L	CAN-H

Connector No.	F25
Connector Name	TCM (TRANSMISSION CONTROL MODULE)
Connector Type	MOLEX 500934-4111

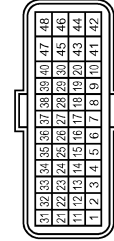

Terminal No.	Color of Wire	Signal Name [Specification]
6	O	K-LINE
31	P	CAN-L
32	L	CAN-H

Connector No.	M4
Connector Name	DATA LINK CONNECTOR
Connector Type	BD18FW

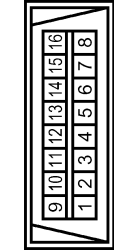

Terminal No.	Color of Wire	Signal Name [Specification]
4	B	-
5	B	-
6	L	-
7	O	-
8	W	-
14	P	-
16	Y	-

Connector No.	M34
Connector Name	COMBINATION METER
Connector Type	SAB40FW

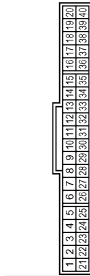

Terminal No.	Color of Wire	Signal Name [Specification]
21	L	CAN-H
22	P	CAN-L

Connector No.	M37
Connector Name	EPS CONTROL UNIT
Connector Type	Molex 88545-0001



Terminal No.	Color of Wire	Signal Name [Specification]
6	P	CAN-L
8	L	CAN-H

Connector No.	M40
Connector Name	INTELLIGENT KEY UNIT
Connector Type	TH40FW



Terminal No.	Color of Wire	Signal Name [Specification]
2	L	CAN-H
3	P	CAN-L

Connector No.	M59
Connector Name	AIR BAG DIAGNOSIS SENSOR UNIT
Connector Type	TK28FY-EX-SC

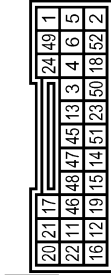

Terminal No.	Color of Wire	Signal Name [Specification]
22	O	K-LINE

JCAWA0028GB

CONSULT-III/GST CHECKING SYSTEM

< BASIC INSPECTION >

CONSULT-III CHECKING SYSTEM

Connector No.	M65
Connector Name	BCM (BODY CONTROL MODULE)
Connector Type	AAB90FB

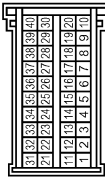

Terminal No.	Color of Wire	Signal Name [Specification]
19	L	CAN-H
20	P	CAN-L

Connector No.	M68
Connector Name	4WD CONTROL UNIT
Connector Type	TH18FW

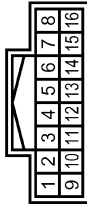

Terminal No.	Color of Wire	Signal Name [Specification]
8	L	CAN-H
18	P	CAN-L

JCAWA0029GE