

SECTION **BL**

BODY, LOCK & SECURITY SYSTEM

A
B
C

CONTENTS

<p>PRECAUTIONS 4</p> <p> Precautions for Supplemental Restraint System (SRS) "AIR BAG" and "SEAT BELT PRE-TENSIONER" 4</p> <p> Precautions for work 4</p> <p>PREPARATION 5</p> <p> Special service tool 5</p> <p> Commercial Service Tool 5</p> <p>SQUEAK AND RATTLE TROUBLE DIAGNOSES..... 6</p> <p> Work Flow 6</p> <p> CUSTOMER INTERVIEW 6</p> <p> DUPLICATE THE NOISE AND TEST DRIVE 7</p> <p> CHECK RELATED SERVICE BULLETINS 7</p> <p> LOCATE THE NOISE AND IDENTIFY THE ROOT CAUSE 7</p> <p> REPAIR THE CAUSE 7</p> <p> CONFIRM THE REPAIR 8</p> <p> Generic Squeak and Rattle Troubleshooting 8</p> <p> INSTRUMENT PANEL 8</p> <p> CENTER CONSOLE 8</p> <p> DOORS 8</p> <p> TRUNK 9</p> <p> SUNROOF/HEADLINING 9</p> <p> OVERHEAD CONSOLE (FRONT AND REAR)..... 9</p> <p> SEATS 9</p> <p> UNDERHOOD 9</p> <p> Diagnostic Worksheet 10</p> <p>HOOD 12</p> <p> Fitting Adjustment 12</p> <p> CLEARANCE AND SURFACE HEIGHT ADJUSTMENT 13</p> <p> HOOD LOCK ADJUSTMENT 13</p> <p> Removal and Installation of Hood Assembly 13</p> <p> Removal and Installation of Hood Lock Control 14</p> <p> REMOVAL 14</p> <p> INSTALLATION 15</p> <p> Hood Lock Control Inspection 15</p> <p>POWER DOOR LOCK SYSTEM 16</p> <p> Component Parts and Harness Connector Location.. 16</p> <p> System Description 17</p>	<p> OUTLINE 18</p> <p> Schematic 19</p> <p> Wiring Diagram — D/LOCK — 20</p> <p> Terminals and Reference Value for BCM 25</p> <p> Work Flow 25</p> <p> CONSULT-II Function (BCM) 26</p> <p> CONSULT-II INSPECTION PROCEDURE 26</p> <p> DATA MONITOR 27</p> <p> ACTIVE TEST 28</p> <p> Trouble Diagnoses Symptom Chart 29</p> <p> BCM Power Supply and Ground Circuit Check 29</p> <p> Door Switch Check 31</p> <p> Key Switch (Insert) Check 33</p> <p> Door Lock/Unlock Switch Check 34</p> <p> Glass Hatch Switch Circuit Inspection 36</p> <p> Front Door Lock Assembly LH (Actuator) Check ... 38</p> <p> Front Door Lock Actuator RH Check 39</p> <p> Rear Door Lock Actuator RH/LH Check 40</p> <p> Glass Hatch Lock Actuator Check 41</p> <p> FrontDoorLockAssemblyLH(KeyCylinderSwitch) Check 42</p> <p>REMOTE KEYLESS ENTRY SYSTEM 44</p> <p> Component Parts and Harness Connector Location.. 44</p> <p> System Description 45</p> <p> INPUTS 45</p> <p> OPERATING PROCEDURE 46</p> <p> CAN Communication System Description 48</p> <p> Schematic 49</p> <p> Wiring Diagram — KEYLES — 50</p> <p> 50</p> <p> 51</p> <p> 52</p> <p> Terminals and Reference Value for BCM 53</p> <p> Terminals and Reference Value for IPDM E/R 54</p> <p> CONSULT-II Function (BCM) 55</p> <p> CONSULT-II Inspection Procedure 55</p> <p> "MULTI REMOTE ENT" 55</p> <p> CONSULT-II Application Items 56</p> <p> "MULTI REMOTE ENT" 56</p> <p> Trouble Diagnosis Procedure 59</p>
---	--

D
E

F
G

H
BL

J
K

L
M

BCM Power Supply and Ground Circuit Check	59	Wiring Diagram — B/CLOS —	106
Trouble Diagnoses	60	Terminals and Reference Value for Back Door Control Unit	111
SYMPTOM CHART	60	Terminals and Reference Value for BCM	112
Key Switch (Insert) Check	62	Trouble Diagnosis Procedure	113
Door Switch Check	63	Self-Diagnosis Procedures	113
Keyfob Battery and Function Check	65	INPUT SIGNAL CHECK MODE	113
Remote Keyless Entry Receiver System Check	66	OPERATING CHECK MODE	113
ACC Power Check	68	Diagnosis Chart	114
IPDM E/R Operation Check	68	Back Door Power Supply and Ground Circuit Inspection	115
Check Hazard Function	70	Power Liftgate Switch System Inspection	116
Check Horn Function	70	GLASS HATCH AJAR SWITCH CHECK	117
Check Headlamp Function	70	Back Door Close (Close) Switch System Inspection	118
Check Map Lamp Illumination Function	70	Back Door Close (Cancel) Switch System Inspection	119
ID Code Entry Procedure	71	Pinch Strip System Inspection	121
KEYFOB ID SET UP WITH CONSULT-II	71	Back Door Warning Chime System Inspection	122
KEYFOB ID SET UP WITHOUT CONSULT-II	73	Half-Latch Switch System Inspection	122
Keyfob Battery Replacement	74	Open Switch System Inspection	123
VEHICLE SECURITY (THEFT WARNING) SYSTEM.. 75		Close Switch System Inspection	124
Component Parts and Harness Connector Location	75	Back Door Handle Switch System Inspection	125
System Description	76	Cinch Latch Motor System Inspection	126
DESCRIPTION	76	DOOR	128
POWER SUPPLY AND GROUND CIRCUIT	77	Fitting Adjustment	128
INITIAL CONDITION TO ACTIVATE THE SYSTEM	77	FRONT DOOR	128
VEHICLE SECURITY SYSTEM ALARM OPERATION	77	REAR DOOR	128
VEHICLE SECURITY SYSTEM DEACTIVATION	78	STRIKER ADJUSTMENT	128
PANIC ALARM OPERATION	78	Removal and Installation	129
CAN Communication System Description	78	FRONT DOOR	129
Schematic	79	REAR DOOR	129
Wiring Diagram — VEHSEC —	80	BACK DOOR	130
.....	80	FRONT DOOR LOCK	131
.....	81	Component Structure	131
.....	82	Removal and Installation	131
.....	83	REMOVAL	131
.....	84	INSTALLATION	133
Terminals and Reference Value for BCM	85	Disassembly and Assembly	133
Terminals and Reference Value for IPDM E/R	86	DOOR KEY CYLINDER ASSEMBLY	133
CONSULT-II Function (BCM)	86	REAR DOOR LOCK	134
CONSULT-II INSPECTION PROCEDURE	86	Component Structure	134
CONSULT-II APPLICATION ITEM	88	Removal and Installation	134
Trouble Diagnosis	89	REMOVAL	134
WORK FLOW	89	INSTALLATION	134
Preliminary Check	90	BACK DOOR LOCK	135
Symptom Chart	91	Power Back Door Opener	135
Door Switch Check	92	REMOVAL	135
Hood Switch Check	94	INSTALLATION	135
Combination Meter (Security Indicator Lamp) Check	95	Door Lock Assembly	136
Front Door Lock Assembly LH (Key Cylinder Switch) Check	96	REMOVAL	136
Vehicle Security Horn Alarm Check	98	INSTALLATION	136
Vehicle Security Headlamp Alarm Check	98	IVIS (INFINITI VEHICLE IMMOBILIZER SYSTEM-NATS)	137
Door Lock/Unlock Switch Check	98	Component Parts and Harness Connector Location	137
AUTOMATIC BACK DOOR SYSTEM	99	System Description	138
Component Parts and Harness Connector Location	99	System Composition	138
System Description	100	ECM Re-communicating Function	139
OPERATION DESCRIPTION	100	Wiring Diagram — NATS —	140
Schematic	105	Terminals and Reference Value for BCM	141

CONSULT-II	141	UNDERCOATING	167	
CONSULT-II INSPECTION PROCEDURE	141	Body Sealing	168	A
CONSULT-II DIAGNOSTIC TEST MODE FUNC-		DESCRIPTION	168	
TION	142	Body Construction	171	
HOW TO READ SELF-DIAGNOSTIC RESULTS	143	BODY CONSTRUCTION	171	B
IVIS (NATS) SELF-DIAGNOSTIC RESULTS		Body Alignment	172	
ITEM CHART	143	BODY CENTER MARKS	172	
Work Flow	144	PANEL PARTS MATCHING MARKS	173	C
Trouble Diagnoses	145	DESCRIPTION	174	
SYMPTOM MATRIX CHART 1	145	ENGINE COMPARTMENT	175	
SYMPTOM MATRIX CHART 2	146	UNDERBODY	177	
DIAGNOSTIC SYSTEM DIAGRAM	146	PASSENGER COMPARTMENT	180	D
Diagnostic Procedure 1	147	REAR BODY	185	
Diagnostic Procedure 2	148	Handling Precautions for Plastics	187	
Diagnostic Procedure 3	149	HANDLING PRECAUTIONS FOR PLASTICS .	187	E
Diagnostic Procedure 4	150	LOCATION OF PLASTIC PARTS	188	
Diagnostic Procedure 5	151	Precautions in Repairing High Strength Steel	190	
Diagnostic Procedure 6	154	HIGH STRENGTH STEEL (HSS) USED IN NIS-		F
How to Replace NATS Antenna Amp.	155	SAN VEHICLES	190	
HOMELINK UNIVERSAL TRANSCEIVER	156	Foam Repair	192	
Wiring Diagram — TRNSCV —	156	URETHANE FOAM APPLICATIONS	192	
Trouble Diagnoses	157	FILL PROCEDURES	192	G
DIAGNOSTIC PROCEDURE	157	Replacement Operations	193	
CAB AND REAR BODY	159	DESCRIPTION	193	
Body Mounting	159	HOODLEDGE	196	H
BODY REPAIR	160	FRONT PILLAR	197	
Body Exterior Paint Color	160	CENTER PILLAR	200	
Body Component Parts	161	OUTER SILL	202	
UNDERBODY COMPONENT PARTS	161	REAR FENDER	203	BL
BODY COMPONENT PARTS	163	REAR SIDE MEMBER	205	
Corrosion Protection	165	REAR FLOOR REAR	206	
DESCRIPTION	165	CRUSH HORN	207	J
ANTI-CORROSIVE WAX	166			

PRECAUTIONS

PRECAUTIONS

PF0:00001

Precautions for Supplemental Restraint System (SRS) “AIR BAG” and “SEAT BELT PRE-TENSIONER”

EIS008P3

The Supplemental Restraint System such as “AIR BAG” and “SEAT BELT PRE-TENSIONER”, used along with a front seat belt, helps to reduce the risk or severity of injury to the driver and front passenger for certain types of collision. This system includes seat belt switch inputs and dual stage front air bag modules. The SRS system uses the seat belt switches to determine the front air bag deployment, and may only deploy one front air bag, depending on the severity of a collision and whether the front occupants are belted or unbelted. Information necessary to service the system safely is included in the SRS and SB section of this Service Manual.

WARNING:

- To avoid rendering the SRS inoperative, which could increase the risk of personal injury or death in the event of a collision which would result in air bag inflation, all maintenance must be performed by an authorized NISSAN/INFINITI dealer.
- Improper maintenance, including incorrect removal and installation of the SRS, can lead to personal injury caused by unintentional activation of the system. For removal of Spiral Cable and Air Bag Module, see the SRS section.
- Do not use electrical test equipment on any circuit related to the SRS unless instructed to in this Service Manual. SRS wiring harnesses can be identified by yellow and/or orange harnesses or harness connectors.

Precautions for work

EIS008P4

- After removing and installing the opening/closing parts, be sure to carry out fitting adjustments to check their operation.
- Check the lubrication level, damage, and wear of each part. If necessary, grease or replace it.

PREPARATION

PREPARATION

PFP:00002

Special service tool

EIS008P5

The actual shapes of Kent-Moore tools may differ from those of special service tools illustrated here.

Tool number (Kent-Moore No.) Tool name	Description
— (J-39570) Chassis ear	Locating the noise
— (J-43980) NISSAN Squeak and Rattle Kit	Repairing the cause of noise
— (J-43241) Remote Keyless Entry Tester	Used to test keyfobs

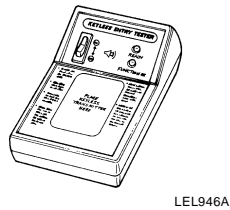
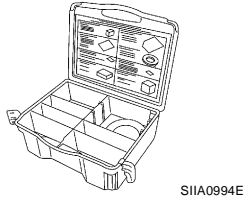
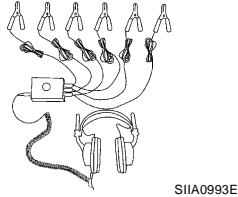

Commercial Service Tool

EIS008P6

Tool name (Kent-Moore No.)	Description
Engine ear (J-39565)	Locating the noise

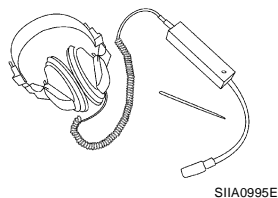

SQUEAK AND RATTLE TROUBLE DIAGNOSES

SQUEAK AND RATTLE TROUBLE DIAGNOSES

PF0:0000

Work Flow

EIS008P7

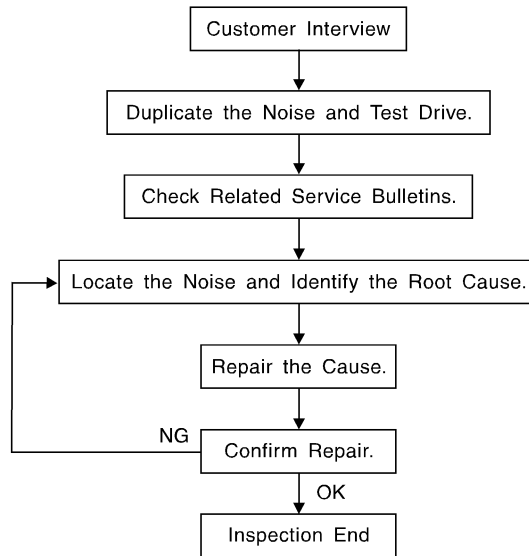

SBT842

CUSTOMER INTERVIEW

Interview the customer if possible, to determine the conditions that exist when the noise occurs. Use the Diagnostic Worksheet during the interview to document the facts and conditions when the noise occurs and any customer's comments; refer to [BL-10, "Diagnostic Worksheet"](#). This information is necessary to duplicate the conditions that exist when the noise occurs.

- The customer may not be able to provide a detailed description or the location of the noise. Attempt to obtain all the facts and conditions that exist when the noise occurs (or does not occur).
- If there is more than one noise in the vehicle, be sure to diagnose and repair the noise that the customer is concerned about. This can be accomplished by test driving the vehicle with the customer.
- After identifying the type of noise, isolate the noise in terms of its characteristics. The noise characteristics are provided so the customer, service adviser and technician are all speaking the same language when defining the noise.
- Squeak —(Like tennis shoes on a clean floor)
Squeak characteristics include the light contact/fast movement/brought on by road conditions/hard surfaces = higher pitch noise/softer surfaces = lower pitch noises/edge to surface = chirping.
- Creak—(Like walking on an old wooden floor)
Creak characteristics include firm contact/slow movement/twisting with a rotational movement/pitch dependent on materials/often brought on by activity.
- Rattle—(Like shaking a baby rattle)
Rattle characteristics include the fast repeated contact/vibration or similar movement/loose parts/missing clip or fastener/incorrect clearance.
- Knock —(Like a knock on a door)
Knock characteristics include hollow sounding/sometimes repeating/often brought on by driver action.
- Tick—(Like a clock second hand)
Tick characteristics include gentle contacting of light materials/loose components/can be caused by driver action or road conditions.
- Thump—(Heavy, muffled knock noise)
Thump characteristics include softer knock/dead sound often brought on by activity.
- Buzz—(Like a bumble bee)
Buzz characteristics include high frequency rattle/firm contact.
- Often the degree of acceptable noise level will vary depending upon the person. A noise that you may judge as acceptable may be very irritating to the customer.
- Weather conditions, especially humidity and temperature, may have a great effect on noise level.

SQUEAK AND RATTLE TROUBLE DIAGNOSES

DUPLICATE THE NOISE AND TEST DRIVE

If possible, drive the vehicle with the customer until the noise is duplicated. Note any additional information on the Diagnostic Worksheet regarding the conditions or location of the noise. This information can be used to duplicate the same conditions when you confirm the repair.

If the noise can be duplicated easily during the test drive, to help identify the source of the noise, try to duplicate the noise with the vehicle stopped by doing one or all of the following:

- 1) Close a door.
 - 2) Tap or push/pull around the area where the noise appears to be coming from.
 - 3) Rev the engine.
 - 4) Use a floor jack to recreate vehicle "twist".
 - 5) At idle, apply engine load (electrical load, half-clutch on M/T model, drive position on A/T model).
 - 6) Raise the vehicle on a hoist and hit a tire with a rubber hammer.
- Drive the vehicle and attempt to duplicate the conditions the customer states exist when the noise occurs.
 - If it is difficult to duplicate the noise, drive the vehicle slowly on an undulating or rough road to stress the vehicle body.

CHECK RELATED SERVICE BULLETINS

After verifying the customer concern or symptom, check ASIST for Technical Service Bulletins (TSBs) related to that concern or symptom.

If a TSB relates to the symptom, follow the procedure to repair the noise.

LOCATE THE NOISE AND IDENTIFY THE ROOT CAUSE

1. Narrow down the noise to a general area. To help pinpoint the source of the noise, use a listening tool (Chassis Ear: J-39570, Engine Ear: J-39565 and mechanic's stethoscope).
2. Narrow down the noise to a more specific area and identify the cause of the noise by:
 - removing the components in the area that you suspect the noise is coming from. Do not use too much force when removing clips and fasteners, otherwise clips and fasteners can be broken or lost during the repair, resulting in the creation of new noise.
 - tapping or pushing/pulling the component that you suspect is causing the noise. Do not tap or push/pull the component with excessive force, otherwise the noise will be eliminated only temporarily.
 - feeling for a vibration with your hand by touching the component(s) that you suspect is (are) causing the noise.
 - placing a piece of paper between components that you suspect are causing the noise.
 - looking for loose components and contact marks.
Refer to [BL-8, "Generic Squeak and Rattle Troubleshooting"](#).

REPAIR THE CAUSE

- If the cause is a loose component, tighten the component securely.
- If the cause is insufficient clearance between components:
 - separate components by repositioning or loosening and retightening the component, if possible.
 - insulate components with a suitable insulator such as urethane pads, foam blocks, felt cloth tape or urethane tape. A NISSAN Squeak and Rattle Kit (J-43980) is available through your authorized NISSAN Parts Department.

CAUTION:

Do not use excessive force as many components are constructed of plastic and may be damaged.

Always check with the Parts Department for the latest parts information.

The following materials are contained in the NISSAN Squeak and Rattle Kit (J-43980). Each item can be ordered separately as needed.

URETHANE PADS [1.5 mm (0.059 in) thick]

Insulates connectors, harness, etc.

76268-9E005: 100×135 mm (3.94×5.31 in)/76884-71L01: 60×85 mm (2.36×3.35 in)/76884-71L02: 15×25 mm (0.59×0.98 in)

INSULATOR (Foam blocks)

Insulates components from contact. Can be used to fill space behind a panel.

73982-9E000: 45 mm (1.77 in) thick, 50×50 mm (1.97×1.97 in)/73982-50Y00: 10 mm (0.39 in) thick, 50×50 mm (1.97×1.97 in)

INSULATOR (Light foam block)

SQUEAK AND RATTLE TROUBLE DIAGNOSES

80845-71L00: 30 mm (1.18 in) thick, 30×50 mm (1.18×1.97 in)

FELT CLOTH TAPE

Used to insulate where movement does not occur. Ideal for instrument panel applications.

68370-4B000: 15×25 mm (0.59×0.98 in) pad/68239-13E00: 5 mm (0.20 in) wide tape roll. The following materials not found in the kit can also be used to repair squeaks and rattles.

UHMW (TEFLON) TAPE

Insulates where slight movement is present. Ideal for instrument panel applications.

SILICONE GREASE

Used instead of UHMW tape that will be visible or not fit.

Note: Will only last a few months.

SILICONE SPRAY

Use when grease cannot be applied.

DUCT TAPE

Use to eliminate movement.

CONFIRM THE REPAIR

Confirm that the cause of a noise is repaired by test driving the vehicle. Operate the vehicle under the same conditions as when the noise originally occurred. Refer to the notes on the Diagnostic Worksheet.

Generic Squeak and Rattle Troubleshooting

EIS008P8

Refer to Table of Contents for specific component removal and installation information.

INSTRUMENT PANEL

Most incidents are caused by contact and movement between:

1. The cluster lid A and instrument panel
2. Acrylic lens and combination meter housing
3. Instrument panel to front pillar garnish
4. Instrument panel to windshield
5. Instrument panel mounting pins
6. Wiring harnesses behind the combination meter
7. A/C defroster duct and duct joint

These incidents can usually be located by tapping or moving the components to duplicate the noise or by pressing on the components while driving to stop the noise. Most of these incidents can be repaired by applying felt cloth tape or silicone spray (in hard to reach areas). Urethane pads can be used to insulate wiring harness.

CAUTION:

Do not use silicone spray to isolate a squeak or rattle. If you saturate the area with silicone, you will not be able to recheck the repair.

CENTER CONSOLE

Components to pay attention to include:

1. Shifter assembly cover to finisher
2. A/C control unit and cluster lid C
3. Wiring harnesses behind audio and A/C control unit

The instrument panel repair and isolation procedures also apply to the center console.

DOORS

Pay attention to the:

1. Finisher and inner panel making a slapping noise
2. Inside handle escutcheon to door finisher
3. Wiring harnesses tapping
4. Door striker out of alignment causing a popping noise on starts and stops

Tapping or moving the components or pressing on them while driving to duplicate the conditions can isolate many of these incidents. You can usually insulate the areas with felt cloth tape or insulator foam blocks from the NISSAN Squeak and Rattle Kit (J-43980) to repair the noise.

SQUEAK AND RATTLE TROUBLE DIAGNOSES

TRUNK

Trunk noises are often caused by a loose jack or loose items put into the trunk by the owner. In addition look for:

1. Trunk lid bumpers out of adjustment
2. Trunk lid striker out of adjustment
3. The trunk lid torsion bars knocking together
4. A loose license plate or bracket

Most of these incidents can be repaired by adjusting, securing or insulating the item(s) or component(s) causing the noise.

SUNROOF/HEADLINING

Noises in the sunroof/headlining area can often be traced to one of the following:

1. Sunroof lid, rail, linkage or seals making a rattle or light knocking noise
2. Sun visor shaft shaking in the holder
3. Front or rear windshield touching headliner and squeaking

Again, pressing on the components to stop the noise while duplicating the conditions can isolate most of these incidents. Repairs usually consist of insulating with felt cloth tape.

OVERHEAD CONSOLE (FRONT AND REAR)

Overhead console noises are often caused by the console panel clips not being engaged correctly. Most of these incidents are repaired by pushing up on the console at the clip locations until the clips engage.

In addition look for:

1. Loose harness or harness connectors.
2. Front console map/reading lamp lense loose.
3. Loose screws at console attachment points.

SEATS

When isolating seat noise it's important to note the position the seat is in and the load placed on the seat when the noise is present. These conditions should be duplicated when verifying and isolating the cause of the noise.

Cause of seat noise include:

1. Headrest rods and holder
2. A squeak between the seat pad cushion and frame
3. The rear seatback lock and bracket

These noises can be isolated by moving or pressing on the suspected components while duplicating the conditions under which the noise occurs. Most of these incidents can be repaired by repositioning the component or applying urethane tape to the contact area.

UNDERHOOD

Some interior noise may be caused by components under the hood or on the engine wall. The noise is then transmitted into the passenger compartment.

Causes of transmitted underhood noise include:

1. Any component mounted to the engine wall
2. Components that pass through the engine wall
3. Engine wall mounts and connectors
4. Loose radiator mounting pins
5. Hood bumpers out of adjustment
6. Hood striker out of adjustment

These noises can be difficult to isolate since they cannot be reached from the interior of the vehicle. The best method is to secure, move or insulate one component at a time and test drive the vehicle. Also, engine RPM or load can be changed to isolate the noise. Repairs can usually be made by moving, adjusting, securing, or insulating the component causing the noise.

A

B

C

D

E

F

G

H

BL

J

K

L

M

SQUEAK AND RATTLE TROUBLE DIAGNOSES

Diagnostic Worksheet

EIS008P9



SQUEAK & RATTLE DIAGNOSTIC WORKSHEET

Dear Infiniti Customer:

We are concerned about your satisfaction with your Infiniti vehicle. Repairing a squeak or rattle sometimes can be very difficult. To help us fix your Infiniti right the first time, please take a moment to note the area of the vehicle where the squeak or rattle occurs and under what conditions. You may be asked to take a test drive with a service advisor or technician to ensure we confirm the noise you are hearing.

I. WHERE DOES THE NOISE COME FROM? (circle the area of the vehicle)

The illustrations are for reference only, and may not reflect the actual configuration of your vehicle.

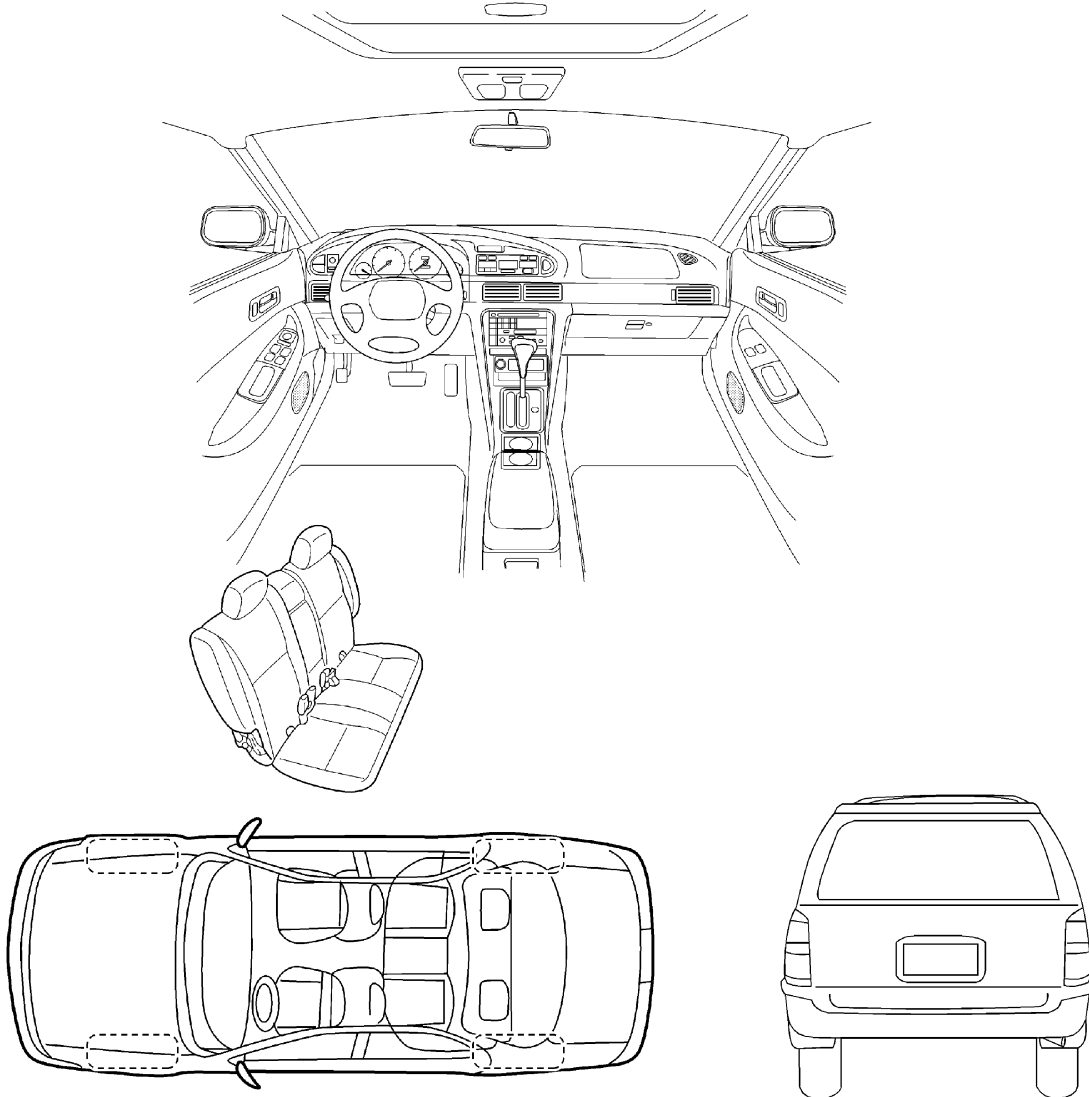

Continue to the back of the worksheet and briefly describe the location of the noise or rattle. In addition, please indicate the conditions which are present when the noise occurs.

SBT860

SQUEAK AND RATTLE TROUBLE DIAGNOSES

SQUEAK & RATTLE DIAGNOSTIC WORKSHEET- page 2

Briefly describe the location where the noise occurs:

II. WHEN DOES IT OCCUR? (check the boxes that apply)

- | | |
|--|---|
| <input type="checkbox"/> anytime | <input type="checkbox"/> after sitting out in the sun |
| <input type="checkbox"/> 1 st time in the morning | <input type="checkbox"/> when it is raining or wet |
| <input type="checkbox"/> only when it is cold outside | <input type="checkbox"/> dry or dusty conditions |
| <input type="checkbox"/> only when it is hot outside | <input type="checkbox"/> other: _____ |

III. WHEN DRIVING:

- through driveways
- over rough roads
- over speed bumps
- only at about ____ mph
- on acceleration
- coming to a stop
- on turns : left, right or either (circle)
- with passengers or cargo
- other: _____
- after driving ____ miles or ____ minutes

IV. WHAT TYPE OF NOISE?

- squeak (like tennis shoes on a clean floor)
- creak (like walking on an old wooden floor)
- rattle (like shaking a baby rattle)
- knock (like a knock on a door)
- tick (like a clock second hand)
- thump (heavy, muffled knock noise)
- buzz (like a bumble bee)

TO BE COMPLETED BY DEALERSHIP PERSONNEL

Test Drive Notes:

	<u>YES</u>	<u>NO</u>	<u>Initials of person performing</u>
Vehicle test driven with customer	<input type="checkbox"/>	<input type="checkbox"/>	_____
- Noise verified on test drive	<input type="checkbox"/>	<input type="checkbox"/>	_____
- Noise source located and repaired	<input type="checkbox"/>	<input type="checkbox"/>	_____
- Follow up test drive performed to confirm repair	<input type="checkbox"/>	<input type="checkbox"/>	_____

VIN: _____ Customer Name: _____

W.O. #: _____ Date: _____

SBT844

This form must be attached to Work Order

HOOD

HOOD

PF5:F5100

Fitting Adjustment

EIS008PA

SEC. 650

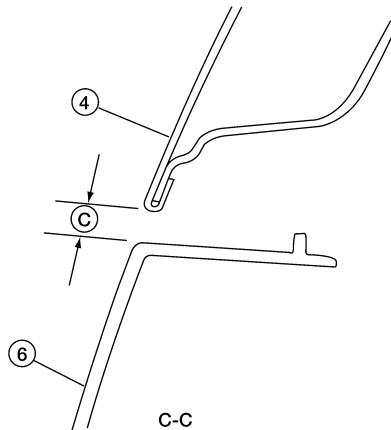
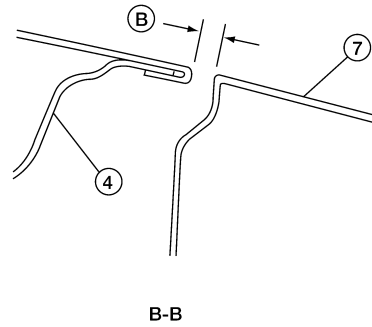
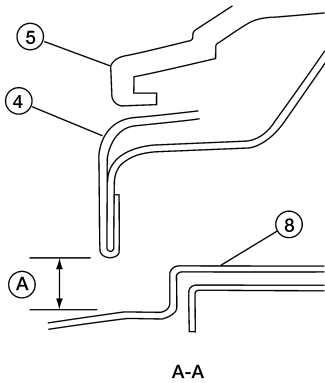
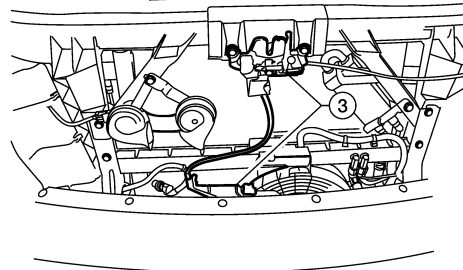
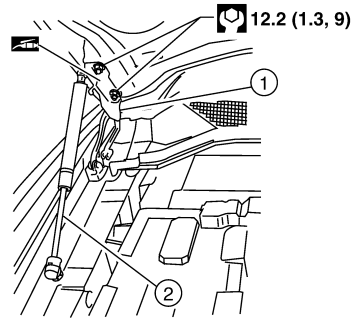
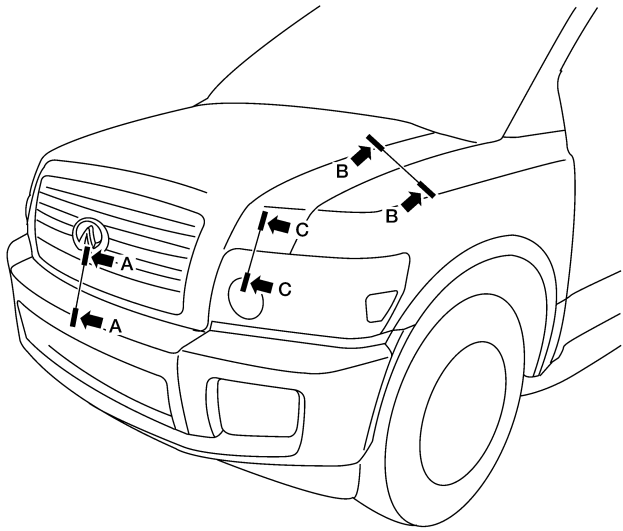

- | | | |
|----------------------|------------------------|-----------------------|
| 1. Hood hinge | 2. Hood stay | 3. Hood lock assembly |
| 4. Hood assembly | 5. Front grille | 6. Headlamp |
| 7. Front fender | 8. Front bumper fascia | A. 8.0 mm (0.315 in) |
| B. 2.0 mm (0.079 in) | C. 8.0 mm (0.315 in) | |

WIIA0899E

HOOD

CLEARANCE AND SURFACE HEIGHT ADJUSTMENT

1. Remove the front grille. Refer to [EI-17, "FRONT GRILLE"](#) .
2. Remove the hood lock assembly and adjust the height by rotating the bumper rubber until the hood clearance of hood and fender becomes 1 mm (0.04 in) lower than fitting standard dimension.
3. Temporarily tighten the hood lock, and position it by engaging it with the hood striker. Check the lock and striker for looseness, and tighten the lock mounting bolt to the specified torque.
4. Adjust the clearance and surface height of hood and fender according to the fitting standard dimension by rotating right and left bumper rubbers.

CAUTION:

Adjust right/left gap between hood and each part to the following specification.

Hood and headlamp (B-B) : Less than 2.0 mm

5. Install the front grille. Refer to [EI-17, "FRONT GRILLE"](#) .

HOOD LOCK ADJUSTMENT

1. Remove the front grille. Refer to [EI-17, "FRONT GRILLE"](#) .
2. Move the hood lock to the left or right so that striker center is vertically aligned with hood lock center (when viewed from vehicle front).
3. Make sure the secondary latch is properly engaged with the secondary striker with hood's own weight by dropping it from approx. 200 mm (7.87 in) height or by pressing it lightly approx. 3 kg (29 N, 7lb).

CAUTION:

Do not drop the hood from 300 mm (11.81 in) height or higher.

4. After adjusting hood lock, tighten the lock bolts.
5. Install the front grille. Refer to [EI-17, "FRONT GRILLE"](#) .

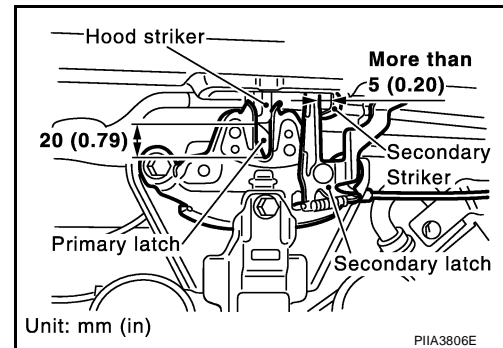

EIS008PB

Removal and Installation of Hood Assembly

1. Support the hood striker with proper material to prevent it from falling.

WARNING:

Body injury may occur if no supporting rod is holding the hood open when removing the damper stay.

2. Remove the hinge nuts from the hood to remove the hood assembly.

CAUTION:

Operate with two workers, because of its heavy weight. Installation is in the reverse order of removal.

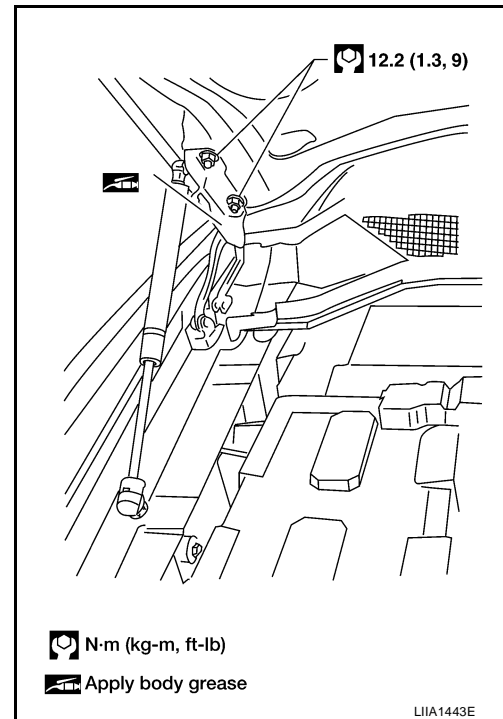

HOOD

Removal and Installation of Hood Lock Control

EIS008PC

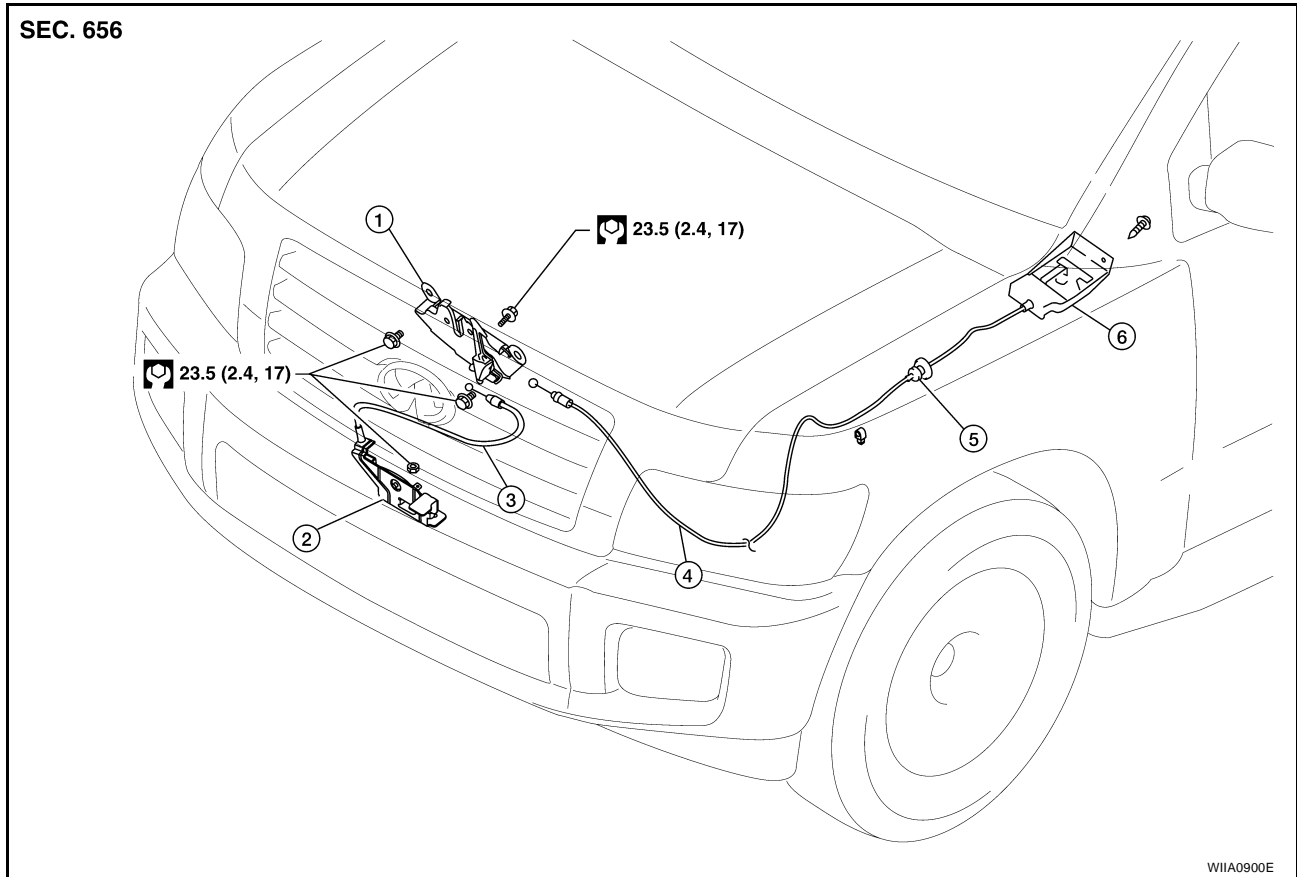

- | | | |
|----------------------------|---|------------------------------|
| 1. Hood lock assembly | 2. Secondary hood lock release assembly | 3. Secondary hood lock cable |
| 4. Primary hood lock cable | 5. Grommet | 6. Hood lock release handle |

REMOVAL

1. Remove the front fender protector (LH). Refer to [EI-23. "FENDER PROTECTOR"](#).
2. Disconnect the hood lock primary and secondary hood lock cables from the hood lock. Unclip the primary cable from the radiator core support upper and hood ledge.
3. Remove the hood lock assembly.
4. Remove the secondary hood lock release assembly.
5. Remove the grommet from the dash lower, and pull the primary hood lock cable into the passenger room.

CAUTION:

While pulling, be careful not to damage the outside of the hood lock cable.

HOOD

INSTALLATION

1. Pull the hood lock cable through the dash lower hole into the engine room.
Be careful not to bend the cable too much, keeping the radius 100mm (3.94 in) or more.
2. Make sure the cable is not offset from the positioning grommet, and push the grommet into the dash lower hole securely.
3. Apply sealant around the grommet at * mark.

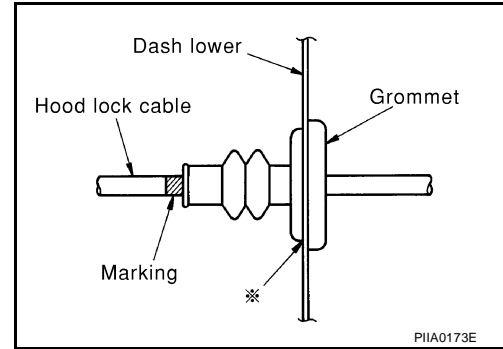

4. Install the primary and secondary cables securely to the hood lock.
5. Install the hood lock and the secondary hood lock release assemblies.
6. Check the hood lock adjustment and hood opener operation.
Refer to [BL-12, "Fitting Adjustment"](#) .

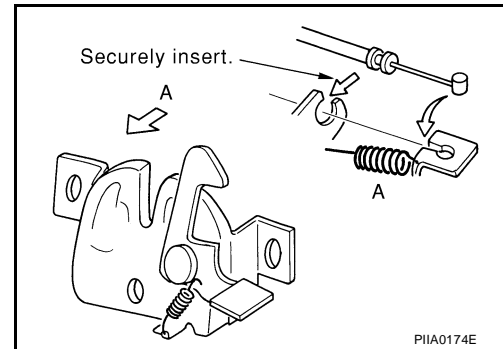

Hood Lock Control Inspection

CAUTION:

If the hood lock cable is bent or deformed, replace it.

1. Remove the front grille. Refer to [EI-17, "FRONT GRILLE"](#) .
2. Make sure the secondary latch is properly engaged with the secondary striker with hood's own weight by dropping it from approx. 200 mm (7.87 in) height.
3. While operating the hood opener, carefully make sure the front end of the hood is raised by approx. 20 mm (0.79 in). Also make sure the hood opener returns to the original position.

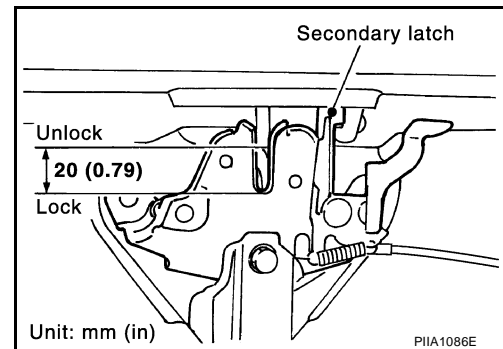

4. Check the hood lock lubrication condition. If necessary, apply "body grease" to the points shown in the figure.
5. Install the front grille. Refer to [EI-17, "FRONT GRILLE"](#) .

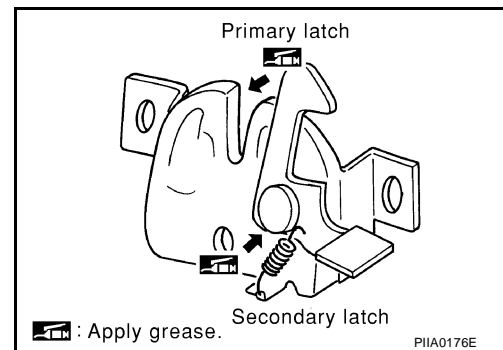

POWER DOOR LOCK SYSTEM

POWER DOOR LOCK SYSTEM

PF:24814

Component Parts and Harness Connector Location

EIS008PE

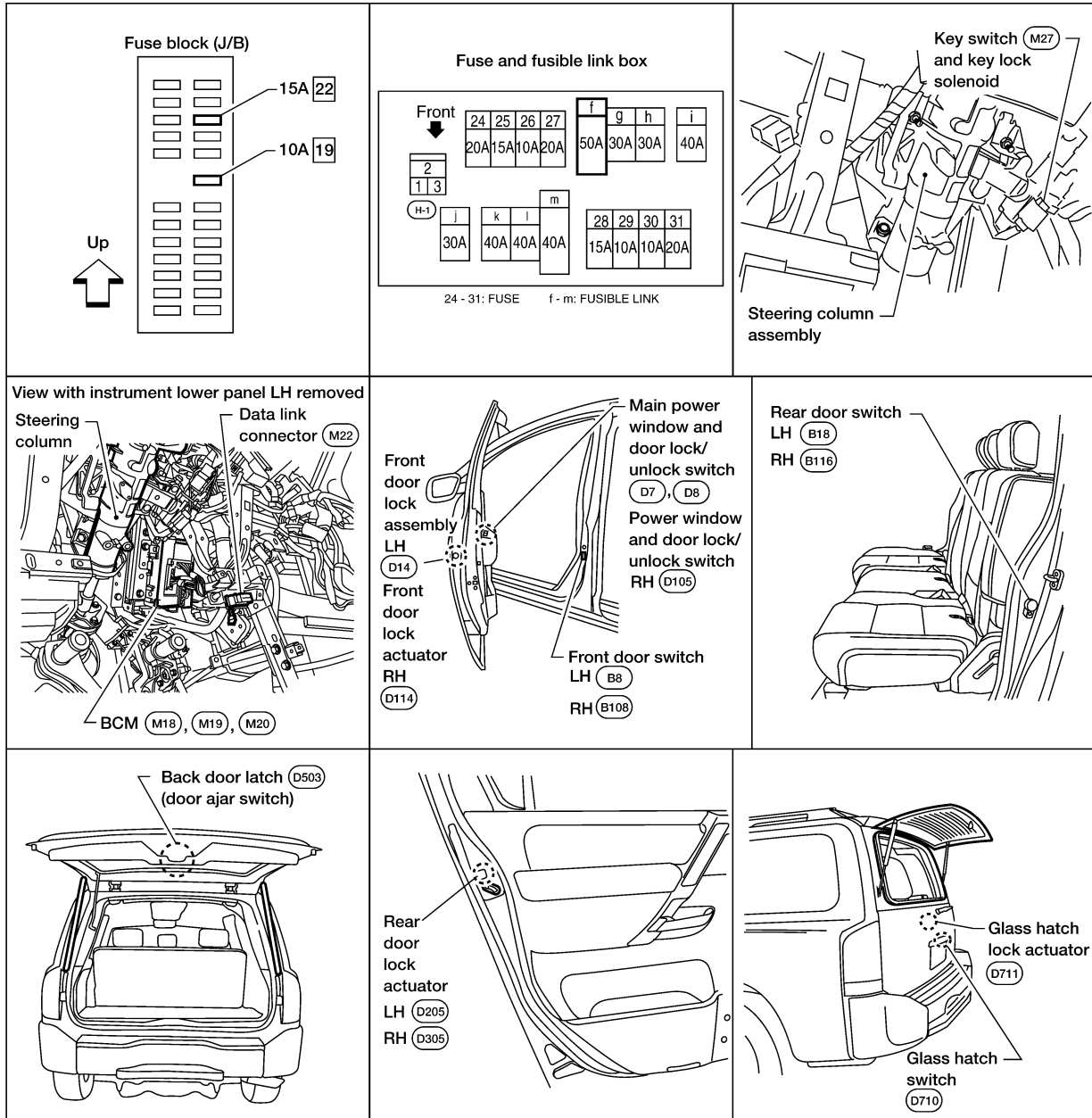

W1A0585E

POWER DOOR LOCK SYSTEM

EIS008PF

System Description

Power is supplied at all times

- through 50A fusible link (letter f, located in the fuse and fusible link box)
- to BCM terminal 70
- through 15A fuse [No. 22, located in the fuse block (J/B)]
- to BCM terminal 57
- through 10A fuse [No. 19, located in the fuse block (J/B)]
- to key switch and key lock solenoid terminal 3.

With ignition key inserted, power is supplied

- through key switch and key lock solenoid terminal 4
- to BCM terminal 37.

Ground is supplied to terminal 67 of BCM through body grounds M57, M61 and M79.

When the door is locked or unlocked with main power window and door lock/unlock switch, ground is supplied

- to CPU of main power window and door lock/unlock switch
- through main power window and door lock/unlock switch terminal 17
- through grounds M57, M61 and M79.

Then main power window and door lock/unlock switch operation signal is supplied

- to BCM terminal 22
- through main power window and door lock/unlock switch terminal 14.

When the door is locked or unlocked with power window and door lock/unlock switch RH, ground is supplied

- to CPU of power window and door lock/unlock switch RH
- through power window and door lock/unlock switch RH terminal 11
- through grounds M57, M61 and M79.

Then power window and door lock/unlock switch RH operation signal is supplied

- to BCM terminal 22
- through power window and door lock/unlock switch RH terminal 16.

When the door is locked with front door lock assembly LH (key cylinder switch), ground is supplied

- to main power window and door lock/unlock switch terminal 4
- through front door lock assembly LH (key cylinder switch) terminals 1 and 5
- through grounds M57, M61 and M79.

Then front door lock assembly LH (key cylinder switch) operation signal is supplied

- to BCM terminal 22
- through main power window and door lock/unlock switch terminal 14.

When the door is unlocked with front door lock assembly LH (key cylinder switch), ground is supplied

- to main power window and door lock/unlock switch terminal 6
- through front door lock assembly LH (key cylinder switch) terminals 6 and 5
- through grounds M57, M61 and M79.

Then front door lock assembly LH (key cylinder switch) operation signal is supplied

- to BCM terminal 22
- through main power window and door lock/unlock switch terminal 14.

BCM is connected to main power window and door lock/unlock switch and power window and door lock/unlock switch RH through a bus.

When the front door switch LH is ON (door is open), ground is supplied

- to BCM terminal 47
- through front door switch LH terminal 2
- through front door switch LH case ground.

When the front door switch RH is ON (door is open), ground is supplied

- to BCM terminal 12
- through front door switch RH terminal 2

A

B

C

D

E

F

G

H

BL

J

K

L

M

POWER DOOR LOCK SYSTEM

- through front door switch RH case ground.

When the rear door switch LH is ON (door is open), ground is supplied

- to BCM terminal 48
- through rear door switch LH terminal 2
- through rear door switch LH case ground.

When the rear door switch RH is ON (door is open), ground is supplied

- to BCM terminal 13
- through rear door switch RH terminal 2
- through rear door switch RH case ground.

When the back door latch (door ajar switch) is ON (door is open), ground is supplied

- to BCM terminal 43
- through back door latch (door ajar switch) terminal 7
- through back door latch (door ajar switch) terminal 8
- through grounds B7 and B19.

OUTLINE

Functions available by operating the door lock and unlock switches on driver door and passenger door

- Interlocked with the locking operation of door lock and unlock switch, door lock actuators of all doors and glass hatch actuator are locked.
- Interlocked with the unlocking operation of door lock and unlock switch, door lock actuators of all doors and glass hatch actuator are unlocked.

Functions available by operating the front door lock assembly LH (key cylinder switch)

- Interlocked with the locking operation of door key cylinder, door lock actuators of all doors are locked.
- When door key cylinder is unlocked, front door lock assembly LH (actuator) is unlocked.
- When door key cylinder is unlocked for the second time within 5 seconds after the first operation, door lock actuators on all doors are unlocked.

Key reminder door system

When door lock and unlock switch is operated to lock doors with ignition key in key cylinder and any door open, all door lock actuators are locked and then unlocked.

POWER DOOR LOCK SYSTEM

Schematic

EIS008PG

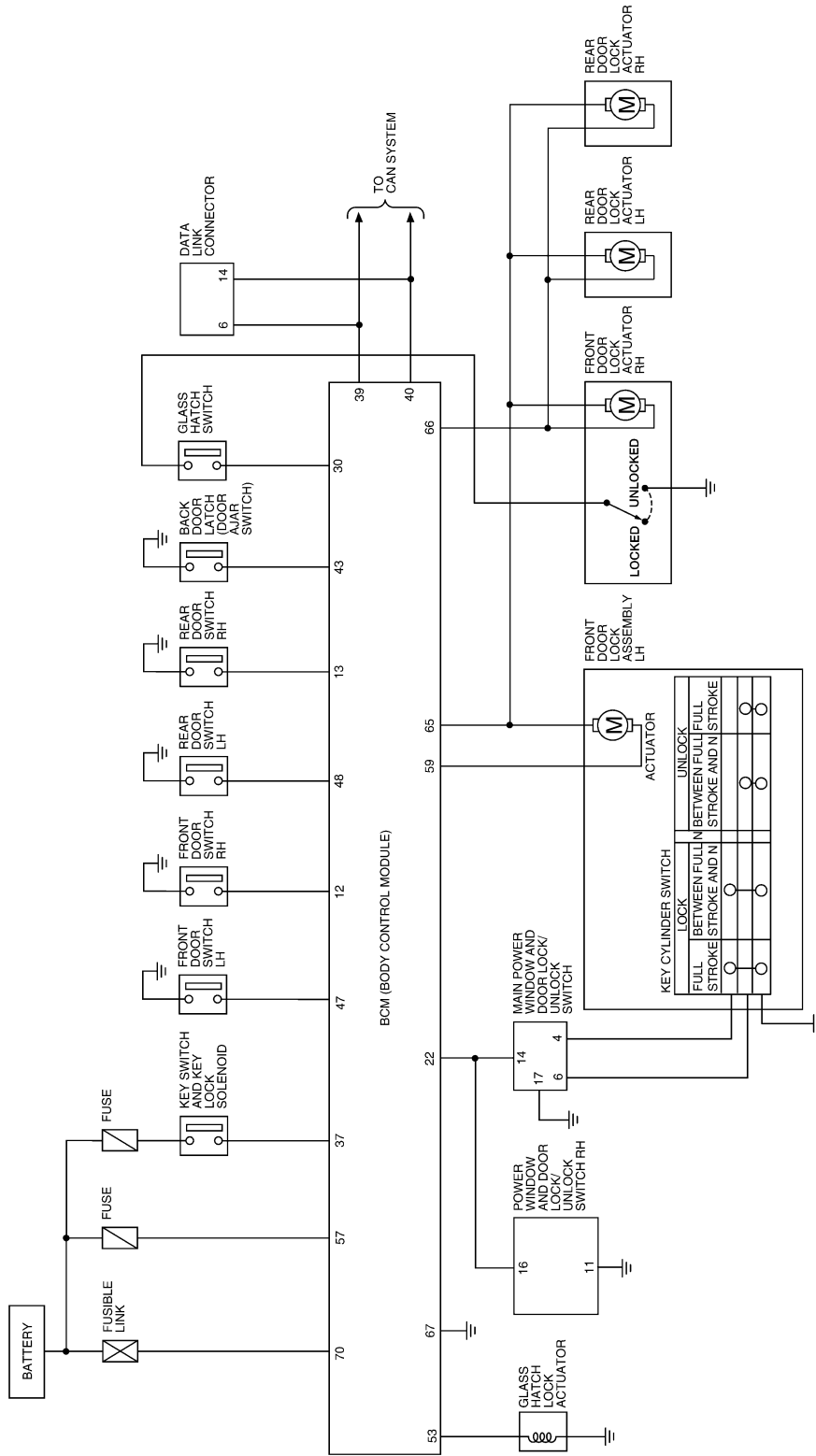

A
B
C
D
E
F
G
H
J
K
L
M

BL

POWER DOOR LOCK SYSTEM

Wiring Diagram — D/LOCK —

EIS008PH

BL-D/LOCK-01

— : DATA LINE

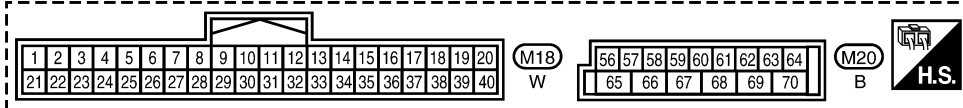
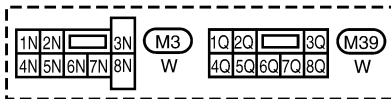
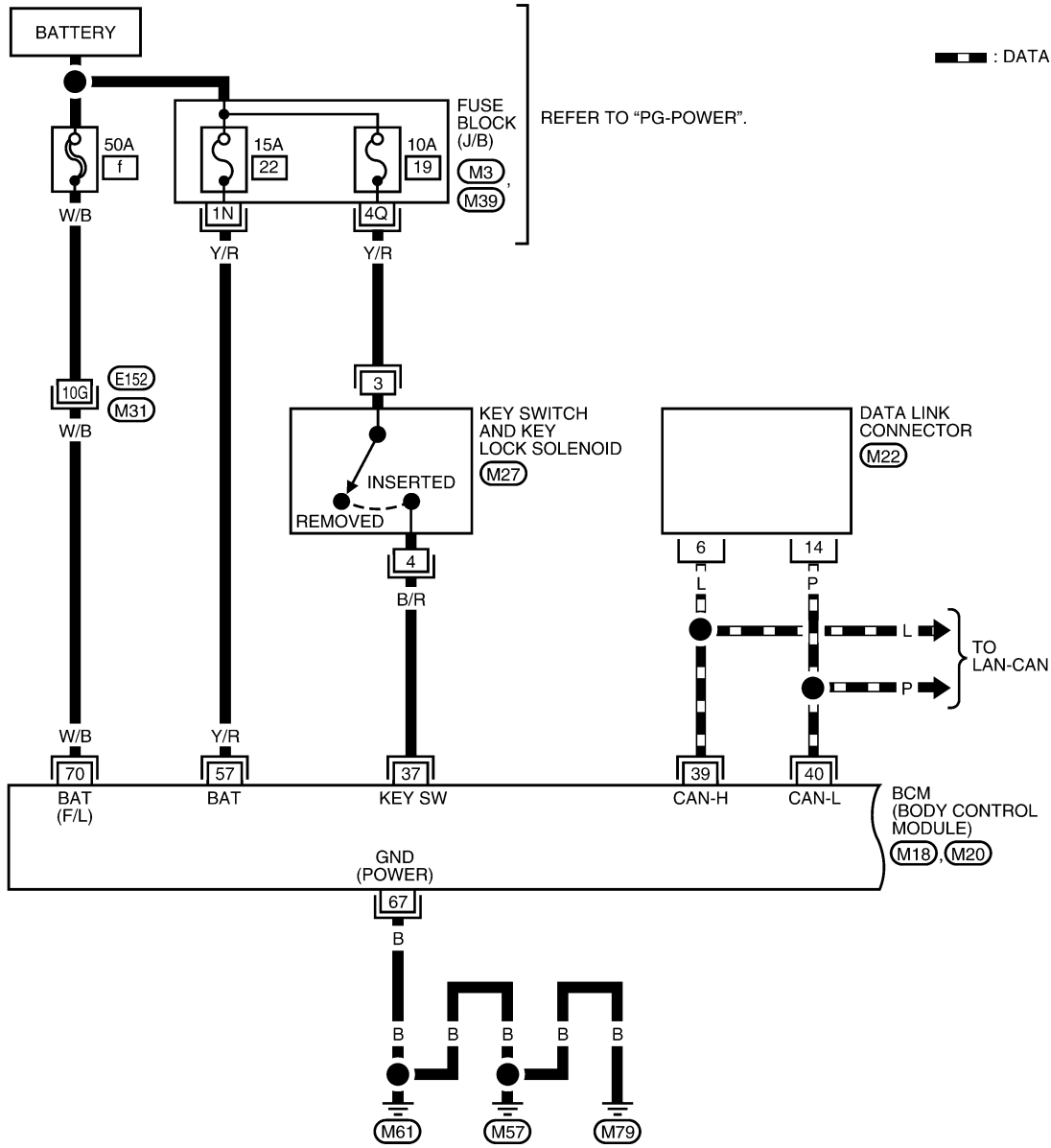

REFER TO THE FOLLOWING.
 (M31) - SUPER MULTIPLE JUNCTION (SMJ)

WIWA0742E

POWER DOOR LOCK SYSTEM

BL-D/LOCK-02

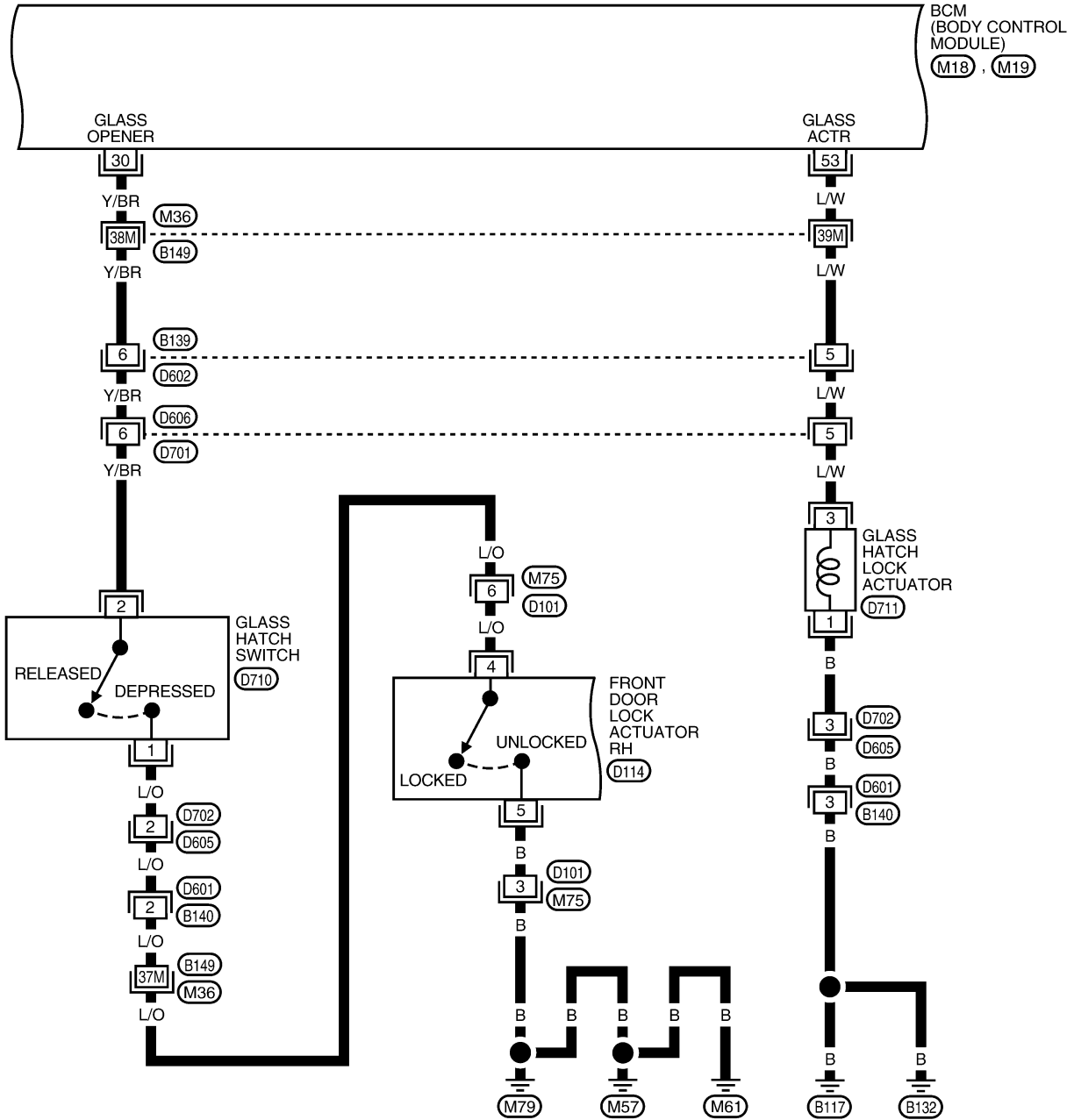

A
B
C
D
E
F
G
H
J
K
L
M

BL

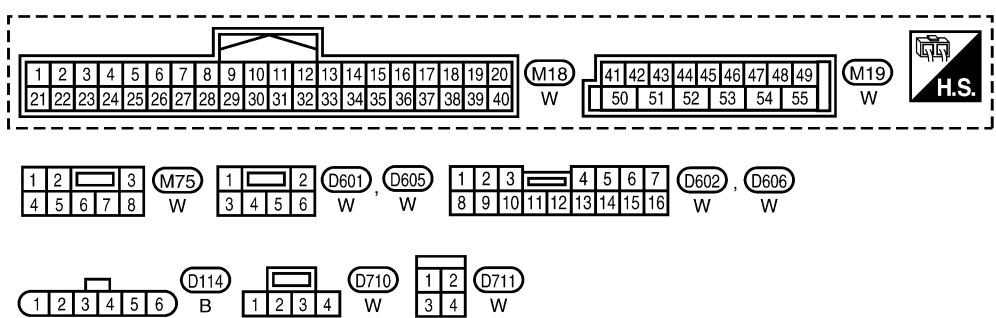

WIWA1724E

POWER DOOR LOCK SYSTEM

BL-D/LOCK-03

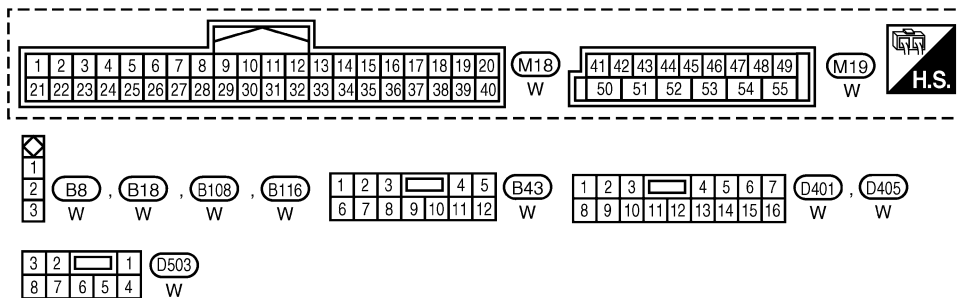
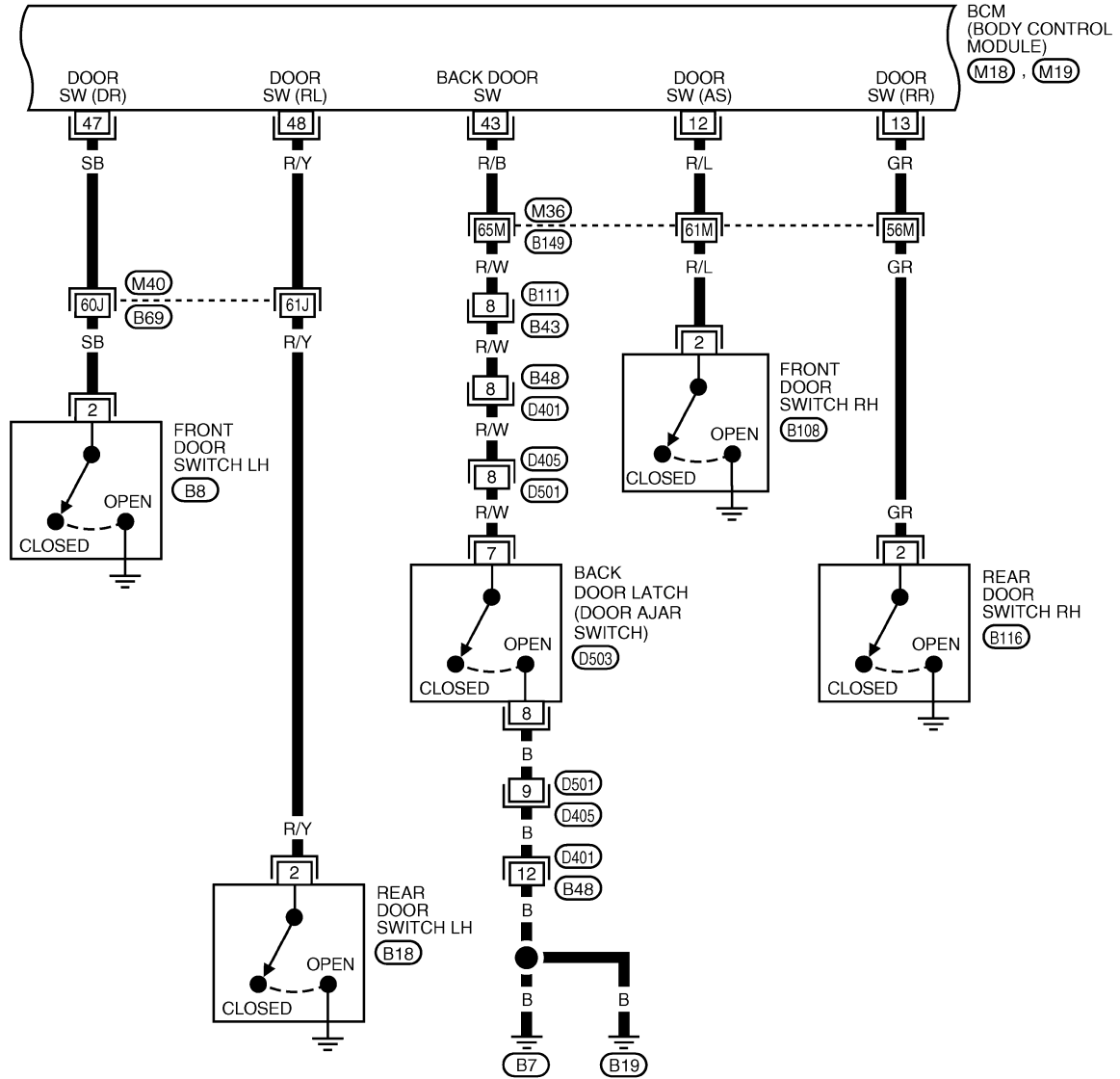

REFER TO THE FOLLOWING.
 (M36), (M40) - SUPER MULTIPLE JUNCTION (SMJ)

LIWA0418E

POWER DOOR LOCK SYSTEM

BL-D/LOCK-04

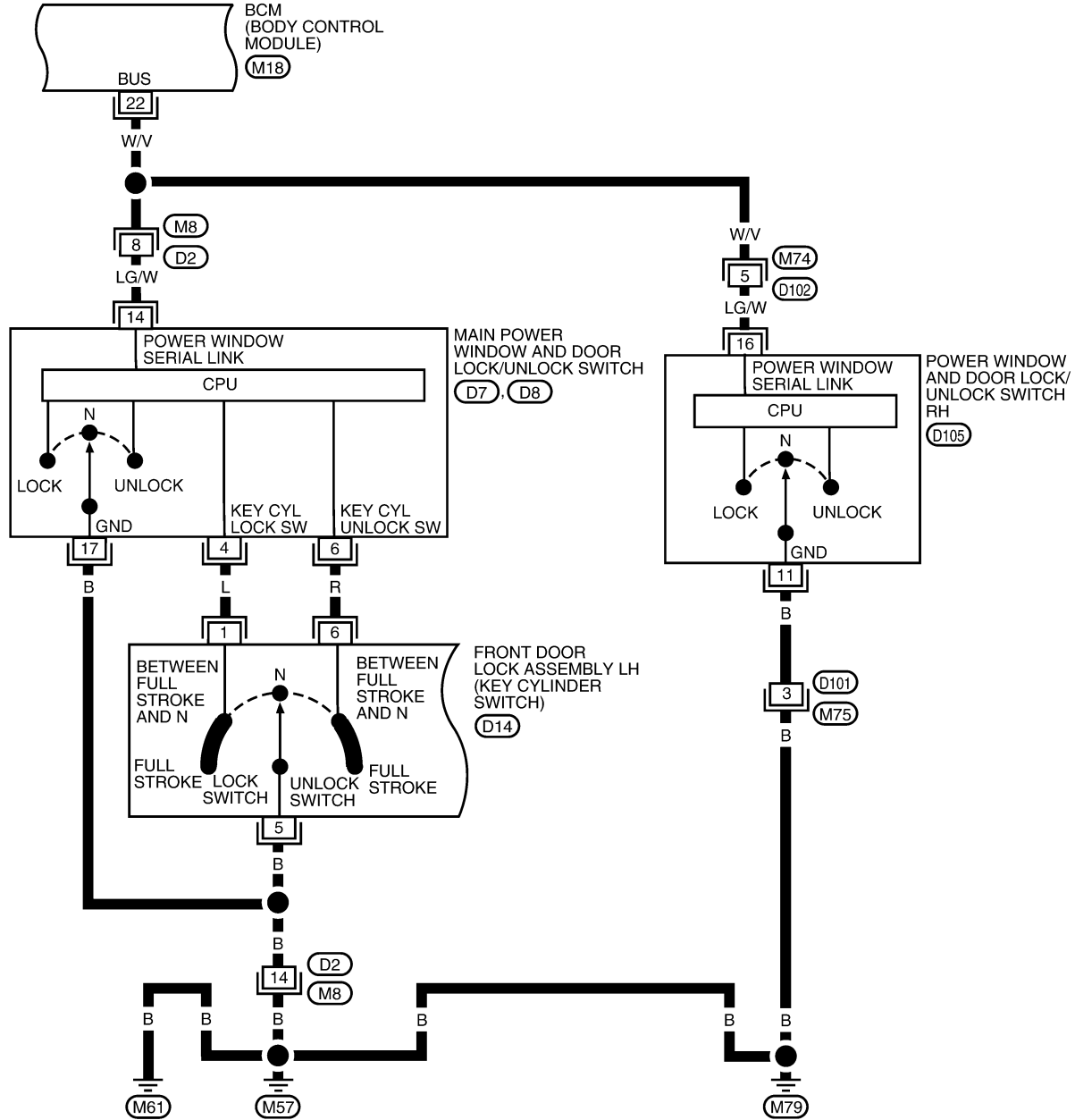

A
B
C
D
E
F
G
H
BL
J
K
L
M

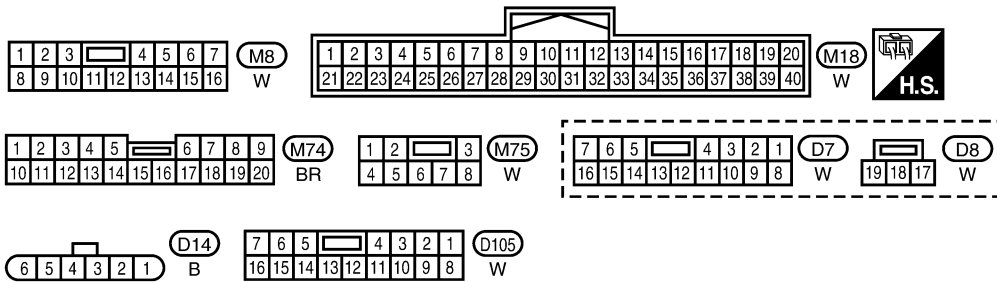

WIWA1306E

POWER DOOR LOCK SYSTEM

BL-D/LOCK-05

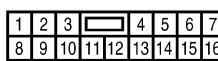
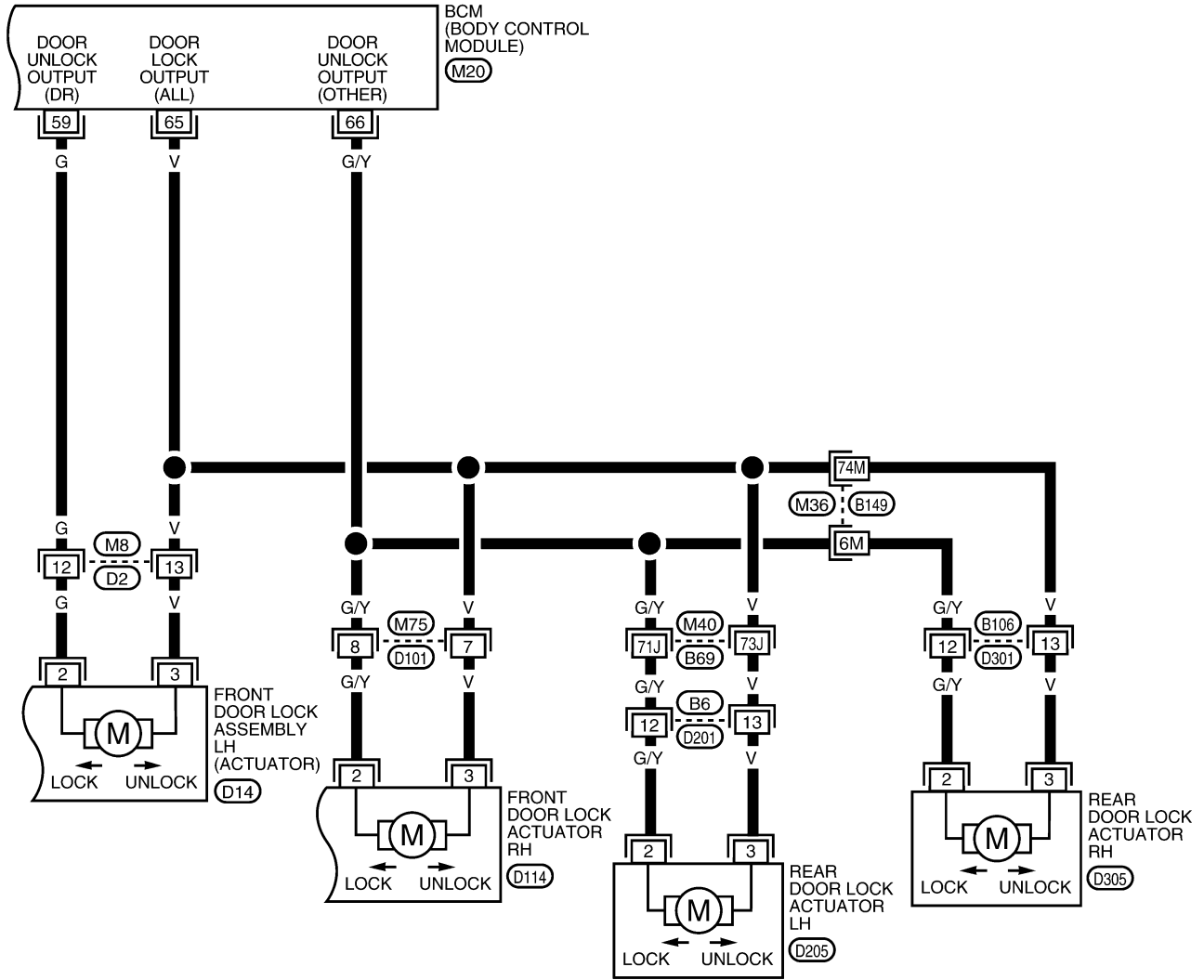

M8
W

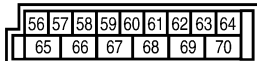

M20
B

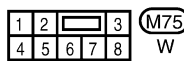

M75
W

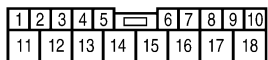

B106
W

B6
W

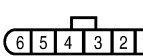

D14
B

D205
B

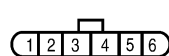

D114
B

D305
B

REFER TO THE FOLLOWING.
M36, M40 - SUPER MULTIPLE JUNCTION (SMJ)

WIWA1725E

POWER DOOR LOCK SYSTEM

Terminals and Reference Value for BCM

E/IS008PI

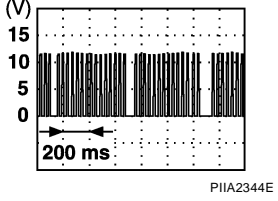
Terminal	Wire Color	Item	Condition	Voltage (V) (Approx.)
12	R/L	Front door switch RH	Door open (ON) → Door close (OFF)	0 → Battery voltage
13	GR	Rear door switch RH	Door open (ON) → Door close (OFF)	0 → Battery voltage
22	W/V	Bus	When ignition switch is ON or power window timer operates	
30	Y/BR	Glass hatch switch	Glass hatch switch released → Glass hatch switch pressed	Battery voltage → 0
37	B/R	Key switch and key lock solenoid (insert)	Key inserted in IGN key cylinder (ON) → Key removed from IGN key cylinder (OFF)	Battery voltage → 0
39	L	CAN-H	—	—
40	P	CAN-L	—	—
43	R/B	Back door latch (door ajar switch)	Door open (ON) → Door close (OFF)	0 → Battery voltage
47	SB	Front door switch LH	Door open (ON) → Door close (OFF)	0 → Battery voltage
48	R/Y	Rear door switch LH	Door open (ON) → Door close (OFF)	0 → Battery voltage
53	L/W	Glass hatch lock actuator	Glass hatch switch released → Glass hatch switch pressed	0 → Battery voltage for 300 msec.
57	Y/R	Battery power supply	—	Battery voltage
59	G	Front door lock assembly LH (actuator) (unlock)	Driver door lock knob (locked → unlocked)	0 → Battery voltage
65	V	All door lock actuators (lock)	Driver door lock knob (neutral → lock)	0 → Battery voltage
66	G/Y	Front door lock actuator RH, rear door lock actuators LH/RH and back door lock actuator (unlock)	Door lock and unlock switch (locked → unlocked)	0 → Battery voltage
67	B	Ground	—	—
70	W/B	Battery power supply	—	Battery voltage

Work Flow

E/IS008PJ

1. Check the symptom and customer's requests.
2. Understand the outline of system. Refer to [BL-17, "System Description"](#) .
3. According to the trouble diagnosis chart, repair or replace the cause of the malfunction. Refer to [BL-29, "Trouble Diagnoses Symptom Chart"](#) .
4. Does power door lock system operate normally? OK: GO TO 5, NG: GO TO 3.
5. Inspection End.

POWER DOOR LOCK SYSTEM

EIS008PK

CONSULT-II Function (BCM)

CONSULT-II can display each diagnostic item using the diagnostic test modes shown following.

BCM diagnostic test item	Diagnostic mode	Description
Inspection by part	WORK SUPPORT	Supports inspections and adjustments. Commands are transmitted to the BCM for setting the status suitable for required operation, input/output signals are received from the BCM and received date is displayed.
	DATA MONITOR	Displays BCM input/output data in real time.
	ACTIVE TEST	Operation of electrical loads can be checked by sending drive signal to them.
	SELF-DIAG RESULTS	Displays BCM self-diagnosis results.
	CAN DIAG SUPPORT MNTR	The result of transmit/receive diagnosis of CAN communication can be read.
	ECU PART NUMBER	BCM part number can be read.
	CONFIGURATION	Performs BCM configuration read/write functions.

CONSULT-II INSPECTION PROCEDURE

CONSULT-II can display each diagnostic item using the following diagnostic test modes: data monitor, active test, and CAN diagnostic support monitor through data reception and command transmission via the BCM communication line.

"DOOR LOCK"

CAUTION:

If CONSULT-II is used with no connection of CONSULT-II CONVERTER, malfunctions might be detected in self-diagnosis depending on control unit which carries out CAN communication.

1. Turn ignition switch OFF.
2. Connect CONSULT-II and CONSULT-II CONVERTER to the data link connector.

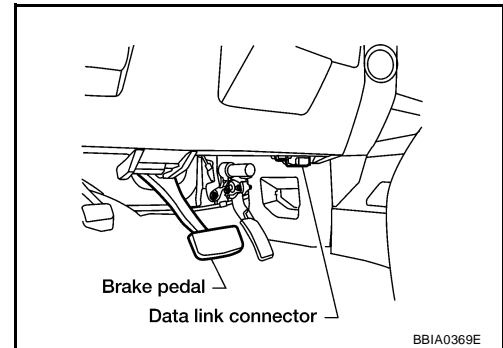

3. Turn ignition switch ON.
4. Touch "START (NISSAN BASED VHCL)".

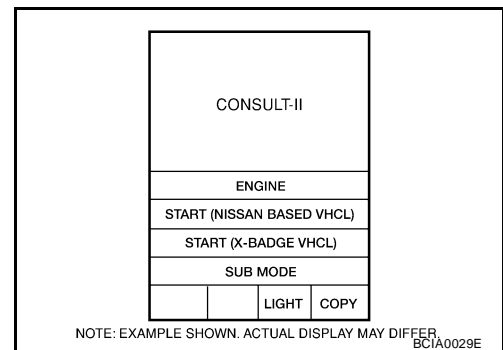

POWER DOOR LOCK SYSTEM

5. Touch "BCM".
If "BCM" is not indicated, refer to [GI-39, "CONSULT-II Data Link Connector \(DLC\) Circuit"](#) .

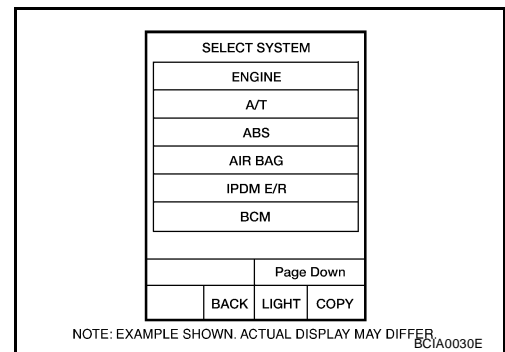

6. Touch "DOOR LOCK".

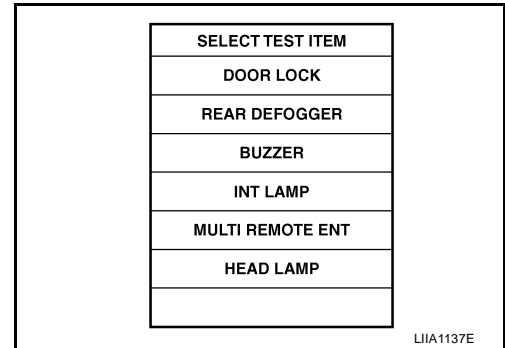

7. Select diagnosis mode.
"DATA MONITOR" and "ACTIVE TEST" are available.

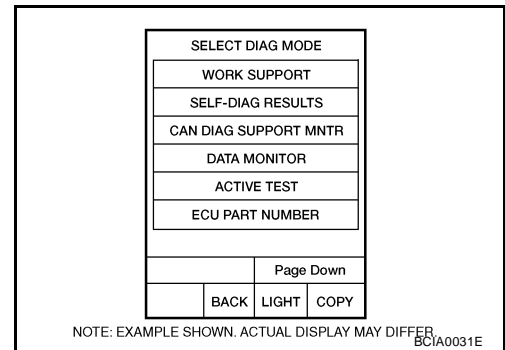

DATA MONITOR

Monitor item "OPERATION"		Content
KEY ON SW	"ON/OFF"	Indicates [ON/OFF] condition of key switch.
CDL LOCK SW	"ON/OFF"	Indicates [ON/OFF] condition of lock signal from lock/unlock switch LH and RH.
CDL UNLOCK SW	"ON/OFF"	Indicates [ON/OFF] condition of unlock signal from lock/unlock switch LH and RH.
KEY CYL LK-SW	"ON/OFF"	Indicates [ON/OFF] condition of lock signal from key cylinder.
KEY CYL UN-SW	"ON/OFF"	Indicates [ON/OFF] condition of unlock signal from key cylinder.
IGN ON SW	"ON/OFF"	Indicates [ON/OFF] condition of ignition switch.
DOOR SW-DR	"ON/OFF"	Indicates [ON/OFF] condition of front door switch LH.
DOOR SW-AS	"ON/OFF"	Indicates [ON/OFF] condition of front door switch RH.
DOOR SW-RR	"ON/OFF"	Indicates [ON/OFF] condition of rear door switch RH.
DOOR SW-RL	"ON/OFF"	Indicates [ON/OFF] condition of rear door switch LH.
BACK DOOR SW	"ON/OFF"	Indicates [ON/OFF] condition of back door latch (door ajar switch).
KEYLESS LOCK	"ON/OFF"	Indicates [ON/OFF] condition of lock signal from keyfob.
KEYLESS UNLOCK	"ON/OFF"	Indicates [ON/OFF] condition of unlock signal from keyfob.

POWER DOOR LOCK SYSTEM

ACTIVE TEST

Test item	Content
ALL LOCK/UNLOCK	This test is able to check all door lock actuators lock operation. These actuators lock when "ON" on CONSULT-II screen is touched.
DR UNLOCK	This test is able to check front door lock assembly LH (actuator) unlock operation. These actuators lock when "ON" on CONSULT-II screen is touched.
OTHER UNLOCK	This test is able to check door lock actuators [except front door lock assembly LH (actuator)] unlock operation. These actuators unlock when "ON" on CONSULT-II screen is touched.

POWER DOOR LOCK SYSTEM

Trouble Diagnoses Symptom Chart

EIS008PL

Symptom	Repair order	Refer to page
Key reminder door function does not operate properly.	1. Door switch check	BL-31
	2. Key switch (insert) check	BL-33
	3. Replace BCM.	BCS-20
Power door lock does not operate with door lock and unlock switch on main power window and door lock/unlock switch or power window and door lock/unlock switch RH.	1. Door lock/unlock switch check	BL-34
	2. Replace BCM.	BCS-20
Front door lock assembly LH (actuator) does not operate.	1. Front door lock assembly LH (Actuator) check	BL-38
Specific door lock actuator does not operate.	1. Front door lock actuator RH check	BL-39
	2. Rear door lock actuator RH/LH check	BL-40
	3. Back door	BL-99
Power door lock does not operate with front door key cylinder LH operation.	1. Front door lock assembly LH (key cylinder switch) check	BL-42
	2. Replace BCM.	BCS-20
Power door lock does not operate.	1. BCM power supply and ground circuit check	BL-29
	2. Door lock/unlock switch check	BL-34
Back door opener does not operate.	1. Back door power supply and ground circuit inspection	BL-115
	2. Door switch check	BL-31
	3. Power liftgate switch system inspection	BL-116
Glass hatch lock actuator does not operate.	1. Glass hatch switch check	BL-36
	2. Glass hatch lock actuator check	BL-41
	3. Replace BCM.	BCS-20

BCM Power Supply and Ground Circuit Check

EIS008PM

1. CHECK FUSE AND FUSIBLE LINK

Check the following BCM fuse and fusible link.

Component Parts	Terminal No. (SIGNAL)	Ampere	No.	Location
BCM	57 (BAT power supply)	15A	22	Fuse block (J/B)
BCM	70 (BAT power supply)	50A	f	Fuse and fusible link box

NOTE:

Refer to [BL-99, "Component Parts and Harness Connector Location"](#) .

OK or NG

OK >> GO TO 2.

NG >> If fuse is blown, be sure to eliminate cause of problem before installing new fuse, refer to [PG-4, "POWER SUPPLY ROUTING CIRCUIT"](#) .

POWER DOOR LOCK SYSTEM

2. CHECK POWER SUPPLY CIRCUIT

1. Turn ignition switch OFF.
2. Disconnect BCM.
3. Check voltage between BCM connector M20 terminals 57, 70 and ground.

Connector	Terminals		Voltage (V) (Approx.)
	(+)	(-)	
M20	57	Ground	Battery voltage
	70		

OK or NG

- OK >> GO TO 3.
 NG >> Repair or replace harness.

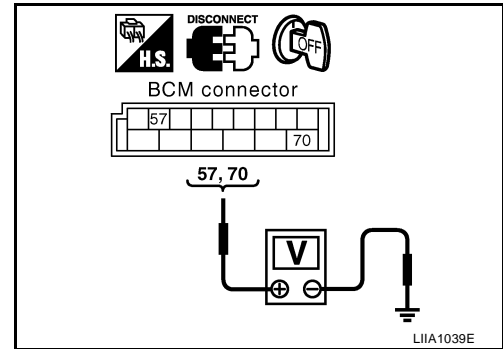

3. CHECK GROUND CIRCUIT

Check continuity between BCM connector M20 terminal 67 and ground.

Connector	Terminals	Continuity
M20	67	Ground
		Yes

OK or NG

- OK >> Power supply and ground circuit is OK.
 NG >> Repair or replace harness.

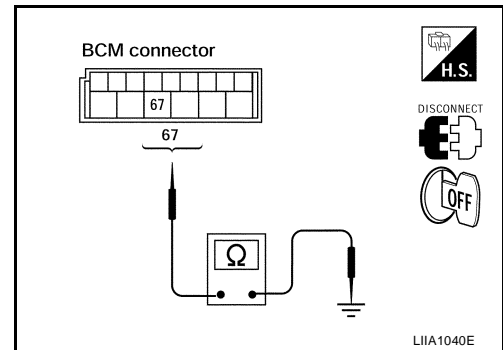

POWER DOOR LOCK SYSTEM

EIS008PN

Door Switch Check

1. CHECK DOOR SWITCHES INPUT SIGNAL

 With CONSULT-II

Check door switches ("DOOR SW-DR", "DOOR SW-AS", "DOOR SW-RL", "DOOR SW-RR", "BACK DOOR SW") in DATA MONITOR mode with CONSULT-II. Refer to [BL-27, "DATA MONITOR"](#).

- When doors are open:

DOOR SW-DR : ON
DOOR SW-AS : ON
DOOR SW-RL : ON
DOOR SW-RR : ON
BACK DOOR SW : ON

- When doors are closed:

DOOR SW-DR : OFF
DOOR SW-AS : OFF
DOOR SW-RL : OFF
DOOR SW-RR : OFF
BACK DOOR SW : OFF

DATA MONITOR	
MONITOR	
DOOR SW - DR	OFF
DOOR SW - AS	OFF
DOOR SW - RR	OFF
DOOR SW - RL	OFF
BACK DOOR SW	OFF

LIA0665E

 Without CONSULT-II

Check voltage between BCM connector M18 or M19 terminals 12, 13, 43, 47, 48 and ground.

Connector	Item	Terminals		Condition	Voltage (V) (Approx.)
		(+)	(-)		
M19	Back door latch (door ajar switch)	43	Ground	Open ↓ Closed	0 ↓ Battery voltage
	Front door switch LH	47			
	Rear door switch LH	48			
M18	Front door switch RH	12	Ground	Open ↓ Closed	0 ↓ Battery voltage
	Rear door switch RH	13			

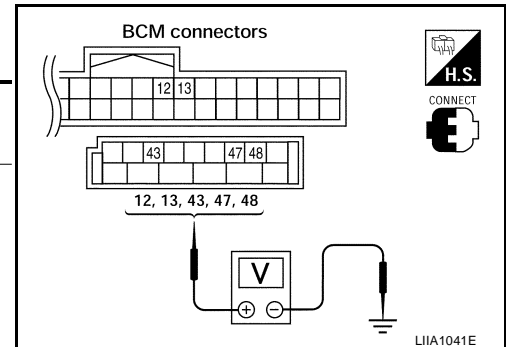

OK or NG

- OK >> Door switch circuit is OK.
 NG >> GO TO 2.

POWER DOOR LOCK SYSTEM

2. CHECK DOOR SWITCH CIRCUIT

1. Turn ignition switch OFF.
2. Disconnect door switch and BCM.
3. Check continuity between door switch connector (B) B8 (front LH), B108 (front RH), B18 (rear LH), B116 (rear RH) terminal 2 or back door latch connector (C) D503 terminal 7 and BCM connectors (A) M18, M19 terminals 12, 13, 43, 47 and 48.

2 - 12 : Continuity should exist.

2 - 13 : Continuity should exist.

2 - 47 : Continuity should exist.

2 - 48 : Continuity should exist.

7 - 43 : Continuity should exist.

4. Check continuity between door switch connector (B) B8 (front LH), B108 (front RH), B18 (rear LH), B116 (rear RH) terminal 2 or back door latch connector (C) D503 terminal 7 and ground.

2 - Ground : Continuity should not exist.

7 - Ground : Continuity should not exist.

OK or NG

OK >> GO TO 3.

NG >> Repair or replace harness.

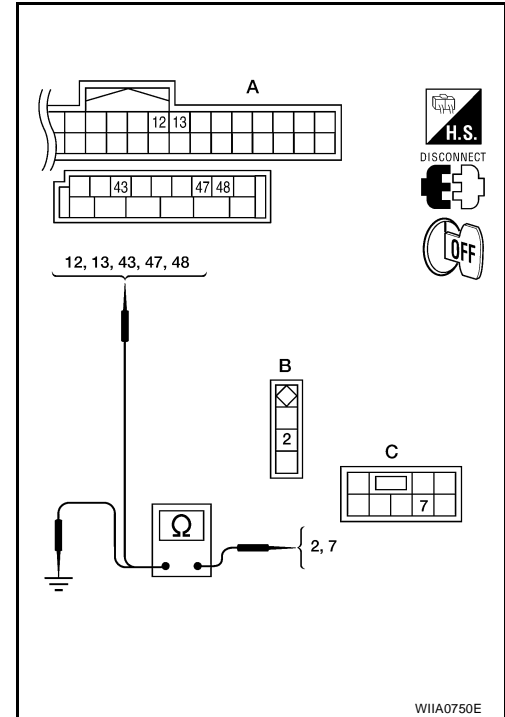

3. CHECK DOOR SWITCHES

FRONT AND REAR DOORS

Check continuity between front or rear door switch terminal 2 and exposed metal of switch while pressing and releasing switch.

Door switch is released : Continuity should exist.

Door switch is pushed : Continuity should not exist.

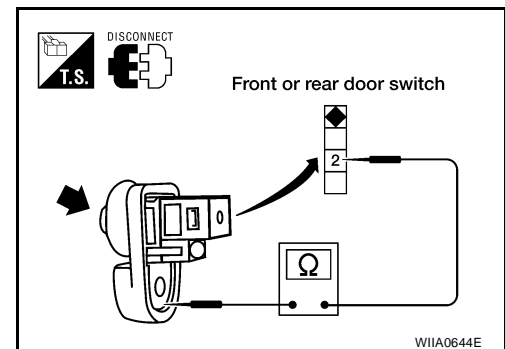

BACK DOOR

Check continuity between back door latch connector (A) D503 terminals 7 and 8 while pressing (closing back door) and releasing (opening back door) switch.

When back door is open : Continuity should exist.

When back door is closed : Continuity should not exist.

OK or NG

OK >> (Front and rear doors) Switch circuit is OK.

OK >> (Back door) GO TO 4.

NG >> Replace door switch.

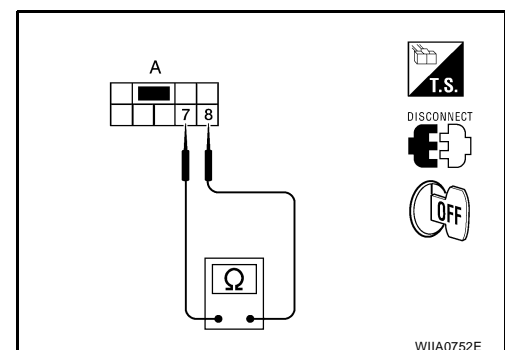

POWER DOOR LOCK SYSTEM

4. CHECK BACK DOOR SWITCH GROUND

Check continuity between back door latch connector terminal 8 and ground.

8 - Ground : Continuity should exist.

OK or NG

- OK >> Back door switch circuit is OK.
- NG >> Repair or replace harness.

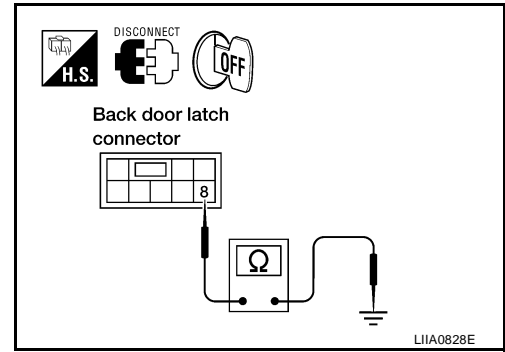

Key Switch (Insert) Check

1. CHECK KEY SWITCH INPUT SIGNAL

With CONSULT-II

Check key switch "KEY ON SW" in DATA MONITOR mode with CONSULT-II. Refer to [BL-27, "DATA MONITOR"](#).

- When key is inserted to ignition key cylinder:
KEY ON SW : ON
- When key is removed from ignition key cylinder:
KEY ON SW : OFF

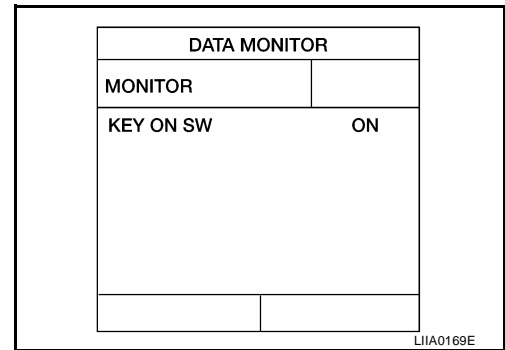

Without CONSULT-II

Check voltage between BCM connector M18 terminal 37 and ground.

Connector	Terminals		Condition	Voltage (V)
	(+)	(-)		
M18	37	Ground	Key is inserted.	Battery voltage
			Key is removed.	0

OK or NG

- OK >> Key switch (insert) circuit is OK.
- NG >> GO TO 2.

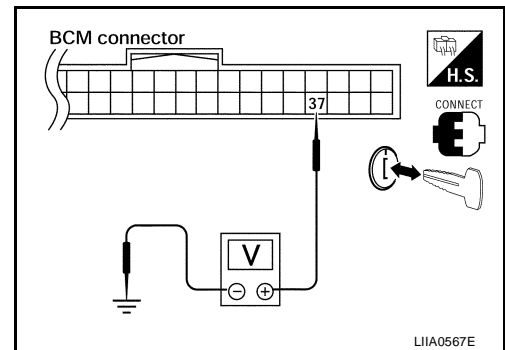

POWER DOOR LOCK SYSTEM

2. CHECK KEY SWITCH (INSERT)

1. Turn ignition switch OFF.
2. Disconnect key switch and key lock solenoid.
3. Check continuity between key switch and key lock solenoid terminals 3, 4.

Terminals	Condition	Continuity
3 - 4	Key is inserted.	Yes
	Key is removed.	No

OK or NG

- OK >> Repair or replace harness.
- NG >> Replace key switch.

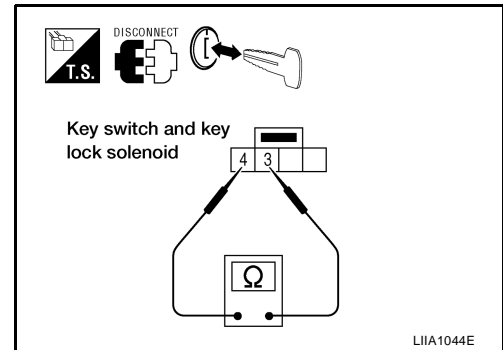

Door Lock/Unlock Switch Check

1. CHECK DOOR LOCK/UNLOCK SWITCH INPUT SIGNAL

With CONSULT-II

Check door lock/unlock switch ("CDL LOCK SW", "CDL UNLOCK SW") in DATA MONITOR mode in CONSULT-II. Refer to [BL-27, "DATA MONITOR"](#)

- When door lock/unlock switch is turned to LOCK:
CDL LOCK SW :ON
- When door lock/unlock switch is turned to UNLOCK:
CDL UNLOCK SW :ON

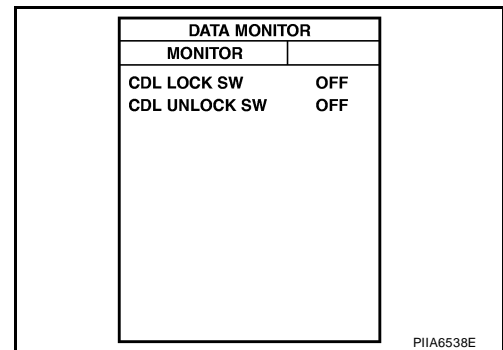

Without CONSULT-II

1. Remove key from ignition key cylinder.
2. Check the signal between BCM connector M18 terminal 22 and ground with oscilloscope when door lock/unlock switch is turned to LOCK or UNLOCK.
3. Make sure the signals which are shown in the figure below can be detected during 10 seconds just after the door lock/unlock switch is turned to LOCK or UNLOCK.

Connector	Terminals		Voltage (V)
	(+)	(-)	
M18	22	Ground	<p>PIIA1297E</p>

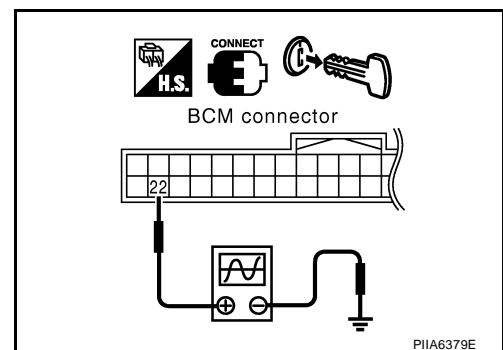

OK or NG

- OK >> Door lock and unlock switch circuit is OK.
- NG >> GO TO 2.

POWER DOOR LOCK SYSTEM

2. CHECK DOOR LOCK/UNLOCK SWITCH GROUND HARNESS

1. Turn ignition switch OFF.
2. Disconnect main power window and door lock/unlock switch or power window and door lock/unlock switch RH
3. Check continuity between main power window and door lock/unlock switch connector D8 terminal 17 and ground.

17 - Ground : Continuity should exist.

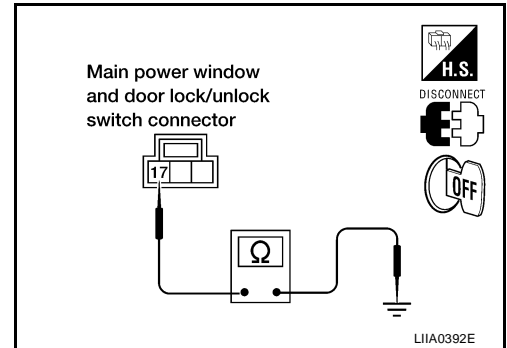

4. Check continuity between power window and door lock/unlock switch RH connector D105 terminal 11 and ground

11 - Ground : Continuity should exist.

OK or NG

OK >> GO TO 3.

NG >> Repair or replace harness.

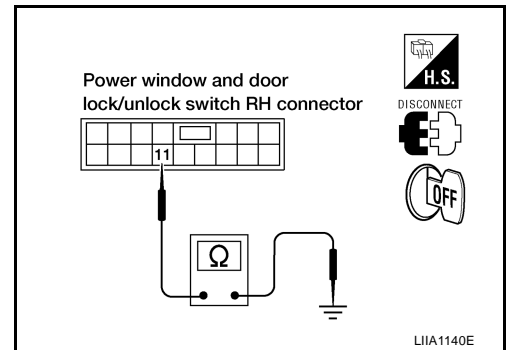

3. CHECK POWER WINDOW BUS CIRCUIT FOR OPEN

1. Disconnect BCM.
2. Check continuity between BCM connector M18 terminal 22 and main power window and door lock/unlock switch connector D7 terminal 14.

22 - 14 : Continuity should exist.

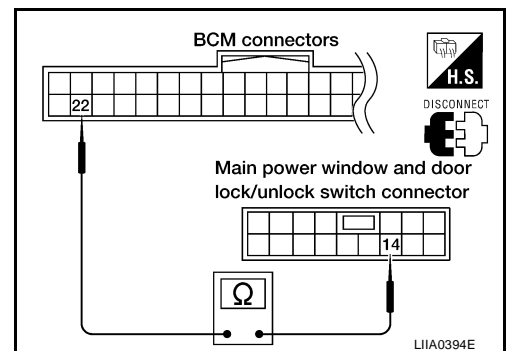

3. Check continuity between BCM connector M18 terminal 22 and power window and door lock/unlock switch RH connector D105 terminal 16.

22 - 16 : Continuity should exist.

OK or NG

OK >> GO TO 4.

NG >> Repair or replace harness.

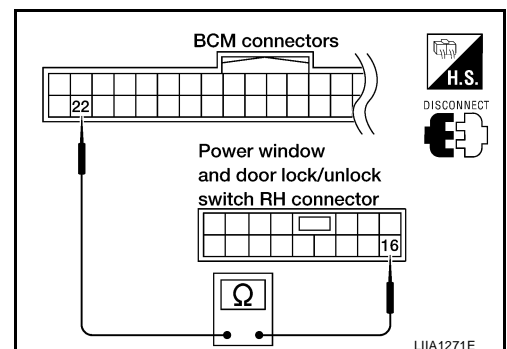

POWER DOOR LOCK SYSTEM

4. CHECK POWER WINDOW BUS CIRCUIT FOR SHORT

Check continuity between BCM connector M18 terminal 22 and ground.

22 - Ground : Continuity should not exist.

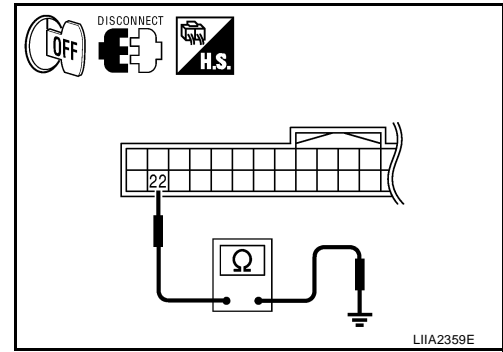

OK or NG

- OK >> Replace main power window and door lock/unlock switch or power window and door lock/unlock switch RH
- NG >> Repair or replace harness.

Glass Hatch Switch Circuit Inspection

E/S008PQ

1. CHECK GLASS HATCH SWITCH

1. Turn ignition switch OFF.
2. Insure front door lock actuator RH is in the unlock position.
3. Check continuity between glass hatch switch terminal 2 and ground.

Connector	Terminals		Condition	Continuity
	(+)	(-)		
D710	2	Ground	With the glass hatch switch pressed	Yes
			With the glass hatch switch released	No

OK or NG

- OK >> GO TO 2.
- NG >> GO TO 3.

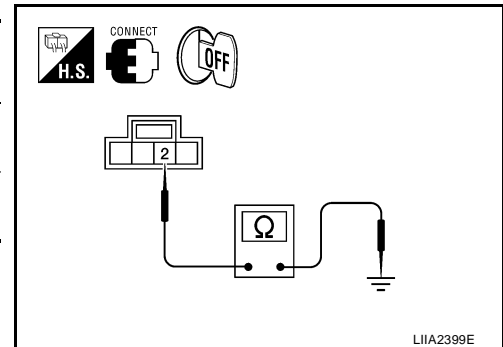

2. CHECK HARNESS CONTINUITY

1. Disconnect glass hatch switch.
2. Disconnect BCM.
3. Check continuity between BCM connector M18 (A) terminal 30 and glass hatch switch connector D710 (B) terminal 2.

30 - 2 : Continuity should exist.

4. Check continuity between BCM connector M18 (A) terminal 30 and ground.

30 - Ground : Continuity should not exist.

OK or NG

- OK >> Glass hatch switch circuit is OK.
- NG >> Repair or replace harness.

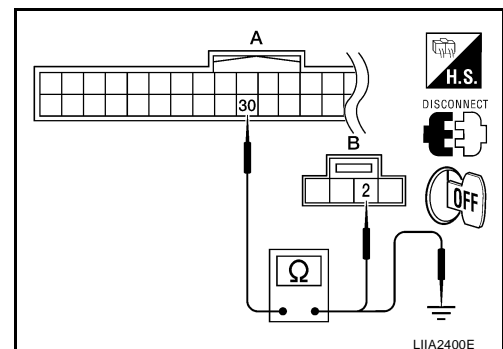

POWER DOOR LOCK SYSTEM

3. CHECK GLASS HATCH SWITCH

1. Disconnect glass hatch switch.
2. Check continuity between glass hatch switch terminal 1 and ground.

1 - Ground : Continuity should exist.

OK or NG

- OK >> Replace glass hatch switch.
NG >> GO TO 4.

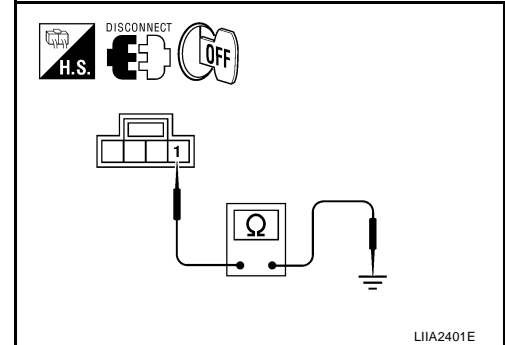

4. CHECK HARNESS CONTINUITY

1. Disconnect front door lock actuator RH.
2. Check continuity between glass hatch switch connector D710 (A) terminal 1 and front door lock actuator RH connector D114 (B) terminal 4

1 - 4 : Continuity should exist.

OK or NG

- OK >> GO TO 5.
NG >> Repair or replace harness.

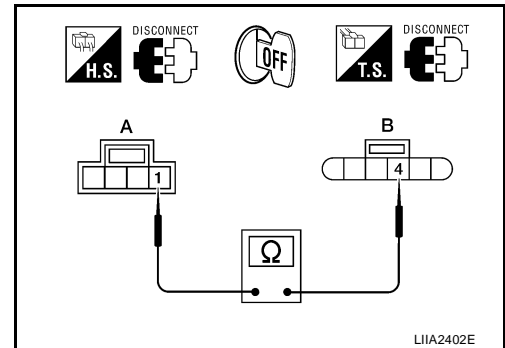

5. CHECK FRONT DOOR LOCK ACTUATOR RH

Check continuity between front door lock actuator RH connector D114 terminal 5 and ground

5 - Ground : Continuity should exist.

OK or NG

- OK >> Replace front door lock actuator RH.
NG >> Repair or replace harness.

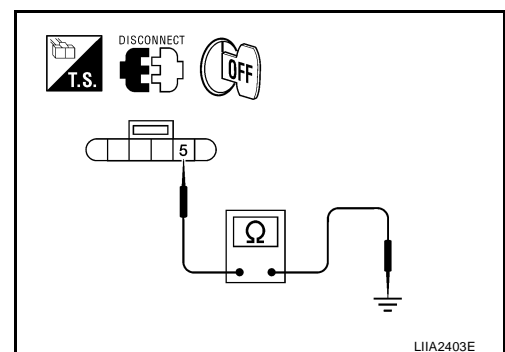

POWER DOOR LOCK SYSTEM

EIS008PR

Front Door Lock Assembly LH (Actuator) Check

1. CHECK DOOR LOCK ACTUATOR SIGNAL

1. Turn ignition switch OFF.
2. Check voltage between BCM connector M20 terminals 59, 65 and ground.

Connector	Terminals		Condition	Voltage (V) (Approx.)
	(+)	(-)		
M20	59	Ground	Driver door lock/unlock switch is turned to UNLOCK	0 → Battery voltage
	65		Driver door lock/unlock switch is turned to LOCK	0 → Battery voltage

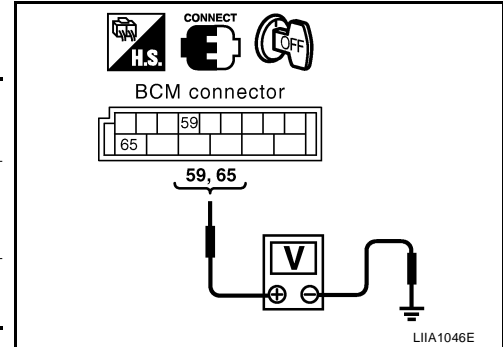

OK or NG

OK >> GO TO 2.

NG >> Replace BCM. Refer to [BCS-20, "Removal and Installation of BCM"](#).

2. CHECK DOOR LOCK ACTUATOR HARNESS

1. Disconnect BCM and front door lock assembly LH (actuator).
2. Check continuity between BCM connector M20 terminals 59, 65 and front door lock assembly LH (actuator) connector D14 terminals 2, 3.

Connector	Terminals	Connector	Terminals	Continuity
M20	59	D14	2	Yes
	65		3	Yes

3. Check continuity between BCM connector M20 terminals 59, 65 and ground.

Connector	Terminals	Continuity
M20	59	No
	65	No

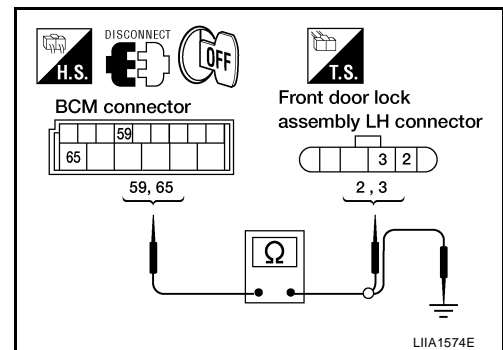

OK or NG

OK >> Replace front door lock assembly LH (actuator). Refer to [BL-131, "FRONT DOOR LOCK"](#).

NG >> Repair or replace harness.

POWER DOOR LOCK SYSTEM

EIS008PS

Front Door Lock Actuator RH Check

1. CHECK FRONT DOOR LOCK ACTUATOR RH SIGNAL

1. Turn ignition switch OFF.
2. Check voltage between BCM connector M20 terminals 65, 66 and ground.

Connector	Terminals		Condition	Voltage (V) (Approx.)
	(+)	(-)		
M20	65	Ground	Door lock/unlock switch is turned to LOCK	0 → Battery voltage for 300 ms
	66		Door lock/unlock switch is turned to UNLOCK	0 → Battery voltage for 300 ms

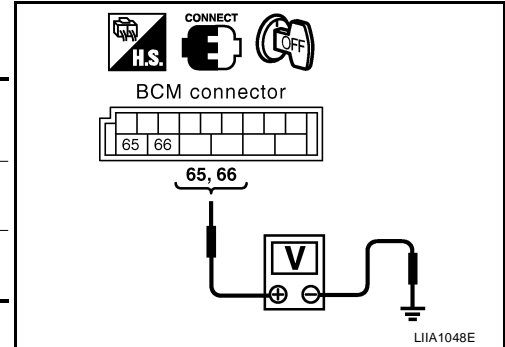

OK or NG

OK >> GO TO 2.

NG >> Replace BCM. Refer to [BCS-20, "Removal and Installation of BCM"](#).

2. CHECK FRONT DOOR LOCK ACTUATOR RH HARNESS

1. Disconnect BCM and front door lock actuator RH.
2. Check continuity between BCM connector M20 terminals 65, 66 and front door lock actuator RH D114 terminals 2, 3.

Terminals		Continuity
65	3	Yes
66	2	Yes

3. Check continuity between BCM connector M20 terminals 65, 66 and ground.

Terminals		Continuity
65	Ground	No
66		No

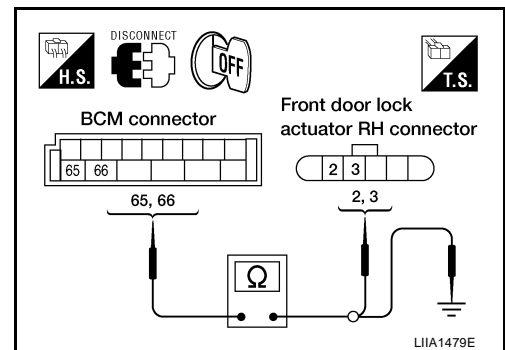

OK or NG

OK >> Replace front door lock actuator RH. Refer to [BL-131, "FRONT DOOR LOCK"](#).

NG >> Repair or replace harness.

POWER DOOR LOCK SYSTEM

EIS008PT

Rear Door Lock Actuator RH/LH Check

1. CHECK DOOR LOCK ACTUATOR SIGNAL

1. Turn ignition switch OFF.
2. Check voltage between BCM connector M20 terminals 65, 66 and ground.

Connector	Terminals		Condition	Voltage (V) (Approx.)
	(+)	(-)		
M20	65	Ground	Door lock/unlock switch is turned to LOCK	0 → Battery voltage for 300 ms
	66		Door lock/unlock switch is turned to UNLOCK	0 → Battery voltage for 300 ms

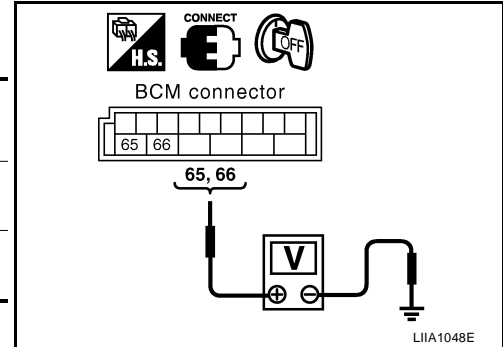

OK or NG

OK >> GO TO 2.

NG >> Replace BCM. Refer to [BCS-20, "Removal and Installation of BCM"](#).

2. CHECK REAR DOOR LOCK ACTUATOR LH OR RH HARNESS

1. Disconnect BCM and each door lock actuator.
2. Check continuity between BCM connector M20 terminals 65, 66 and rear door lock actuator RH/LH connectors terminals 2, 3.

Terminals		Continuity
65	3	Yes
66	2	Yes

3. Check continuity between BCM connector M20 terminals 65, 66 and ground.

Terminals		Continuity
65	Ground	No
66		No

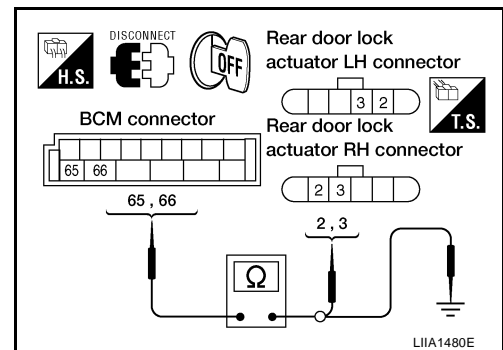

OK or NG

OK >> Replace door lock actuator. Refer to [BL-134, "REAR DOOR LOCK"](#).

NG >> Repair or replace harness.

POWER DOOR LOCK SYSTEM

EIS008PU

Glass Hatch Lock Actuator Check

1. CHECK GLASS HATCH LOCK ACTUATOR SIGNAL

1. Turn ignition switch OFF.
2. Check voltage between BCM connector M19 terminal 53 and ground.

Connector	Terminals		Condition	Voltage (V) (Approx.)
	(+)	(-)		
M19	53	Ground	Glass hatch switch is turned to depressed	0 → Battery voltage for 300 ms

OK or NG

- OK >> GO TO 2.
 NG >> Replace BCM. Refer to [BCS-20, "Removal and Installation of BCM"](#).

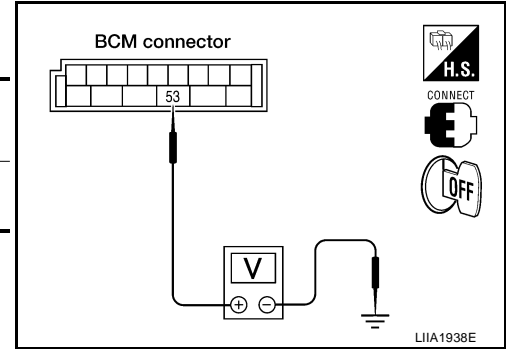

2. CHECK GLASS HATCH LOCK ACTUATOR HARNESS

1. Disconnect BCM and glass hatch lock actuator.
2. Check continuity between BCM connector M19 terminal 53 and glass hatch lock actuator connector D711 terminal 3.

Terminals		Continuity
53	3	Yes

3. Check continuity between BCM connector M19 terminals 53 and ground.

Terminals		Continuity
53	Ground	No

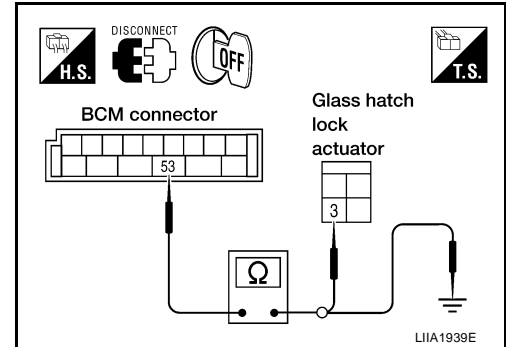

OK or NG

- OK >> GO TO 3.
 NG >> Repair or replace harness.

3. CHECK GLASS HATCH LOCK ACTUATOR GROUND CIRCUIT

1. Disconnect glass hatch lock actuator.
2. Check continuity between glass hatch lock actuator connector D711 terminal 1 and ground.

Terminals		Continuity
1	Ground	Yes

OK or NG

- OK >> Replace glass hatch lock actuator. Refer to [BL-135, "BACK DOOR LOCK"](#).
 NG >> Repair or replace harness.

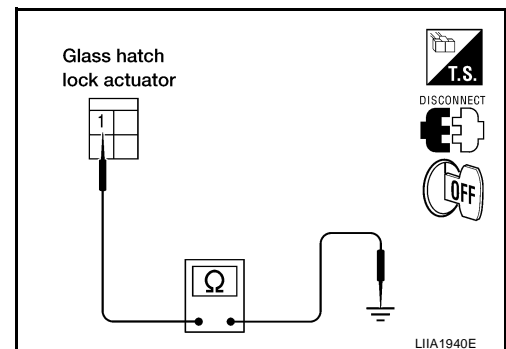

POWER DOOR LOCK SYSTEM

Front Door Lock Assembly LH (Key Cylinder Switch) Check

EIS008PV

1. CHECK DOOR KEY CYLINDER SWITCH LH

☑ With CONSULT-II

Check front door lock assembly LH (key cylinder switch) ("KEY CYL LK-SW") and ("KEY CYL UN-SW") in DATA MONITOR mode with CONSULT-II. Refer to [BL-27, "DATA MONITOR"](#).

- When key inserted in front key cylinder is turned to LOCK:

KEY CYL LK-SW : ON

- When key inserted in front key cylinder is turned to UNLOCK:

KEY CYL UN-SW : ON

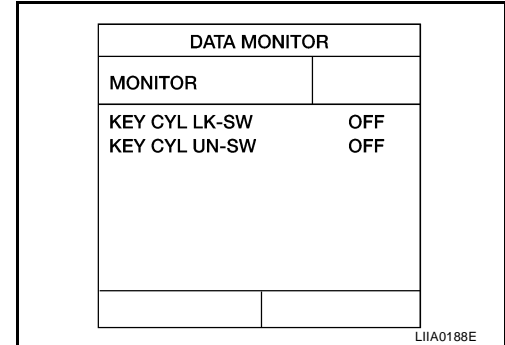

⊗ Without CONSULT-II

Check voltage between main power window and door lock/unlock switch connector D7 terminals 4, 6 and ground.

Connector	Terminals		Condition	Voltage (V) (Approx.)
	(+)	(-)		
D7	4	Ground	Neutral/Unlock	5
			Lock	0
	6		Neutral/Lock	5
			Unlock	0

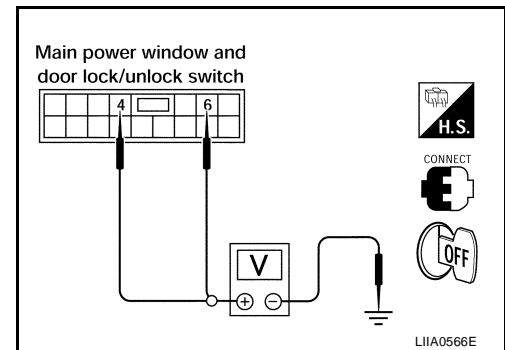

OK or NG

- OK >> Front door lock assembly LH (key cylinder switch) signal is OK.
- NG >> GO TO 2.

2. CHECK DOOR KEY CYLINDER SWITCH LH GROUND HARNESS

Check continuity between front door lock assembly LH (key cylinder switch) connector (A) D14 terminal 5 and body ground.

Connector	Terminals	Continuity
D14	5 – Ground	Yes

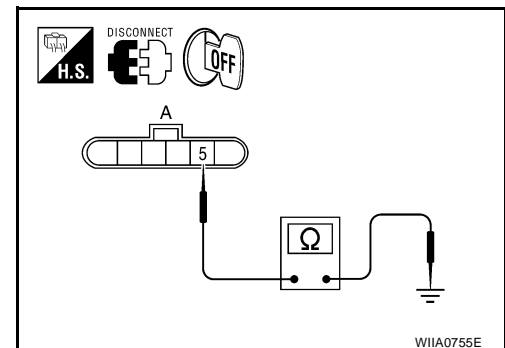

OK or NG

- OK >> GO TO 3.
- NG >> Repair or replace harness.

POWER DOOR LOCK SYSTEM

3. CHECK DOOR KEY CYLINDER SWITCH LH

Check continuity between front door lock assembly LH (key cylinder switch) terminals.

Terminals	Condition	Continuity
1 – 5	Key is turned to UNLOCK or neutral.	No
	Key is turned to LOCK.	Yes
5 – 6	Key is turned to LOCK or neutral.	No
	Key is turned to UNLOCK.	Yes

OK or NG

OK >> GO TO 4.

NG >> Replace front door lock assembly LH (key cylinder switch). Refer to [BL-131, "FRONT DOOR LOCK"](#).

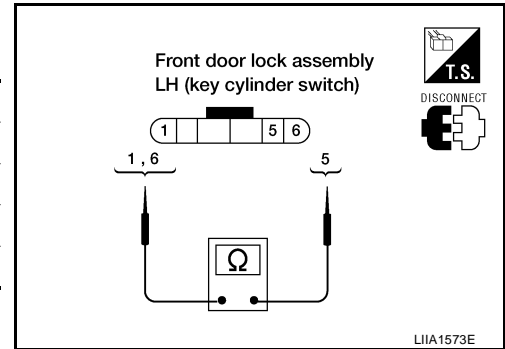

4. CHECK DOOR KEY CYLINDER HARNESS

Check continuity between main power window and door lock/unlock switch connector (A) D7 terminals 4, 6 and front door lock assembly LH (key cylinder switch) connector (B) D14 terminals 1, 6 and body ground.

Connector	Terminals	Connector	Terminals (wire color)	Continuity
A: Main power window and door lock/unlock switch	4	B: Front door lock assembly LH (key cylinder switch)	1	Yes
	6		6	Yes
	4, 6	Ground	No	

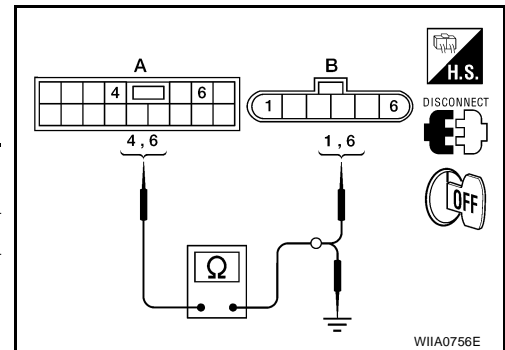

OK or NG

OK >> Replace main power window and door lock/unlock switch.

NG >> Repair or replace harness.

REMOTE KEYLESS ENTRY SYSTEM

REMOTE KEYLESS ENTRY SYSTEM

PF:28596

Component Parts and Harness Connector Location

EIS008PW

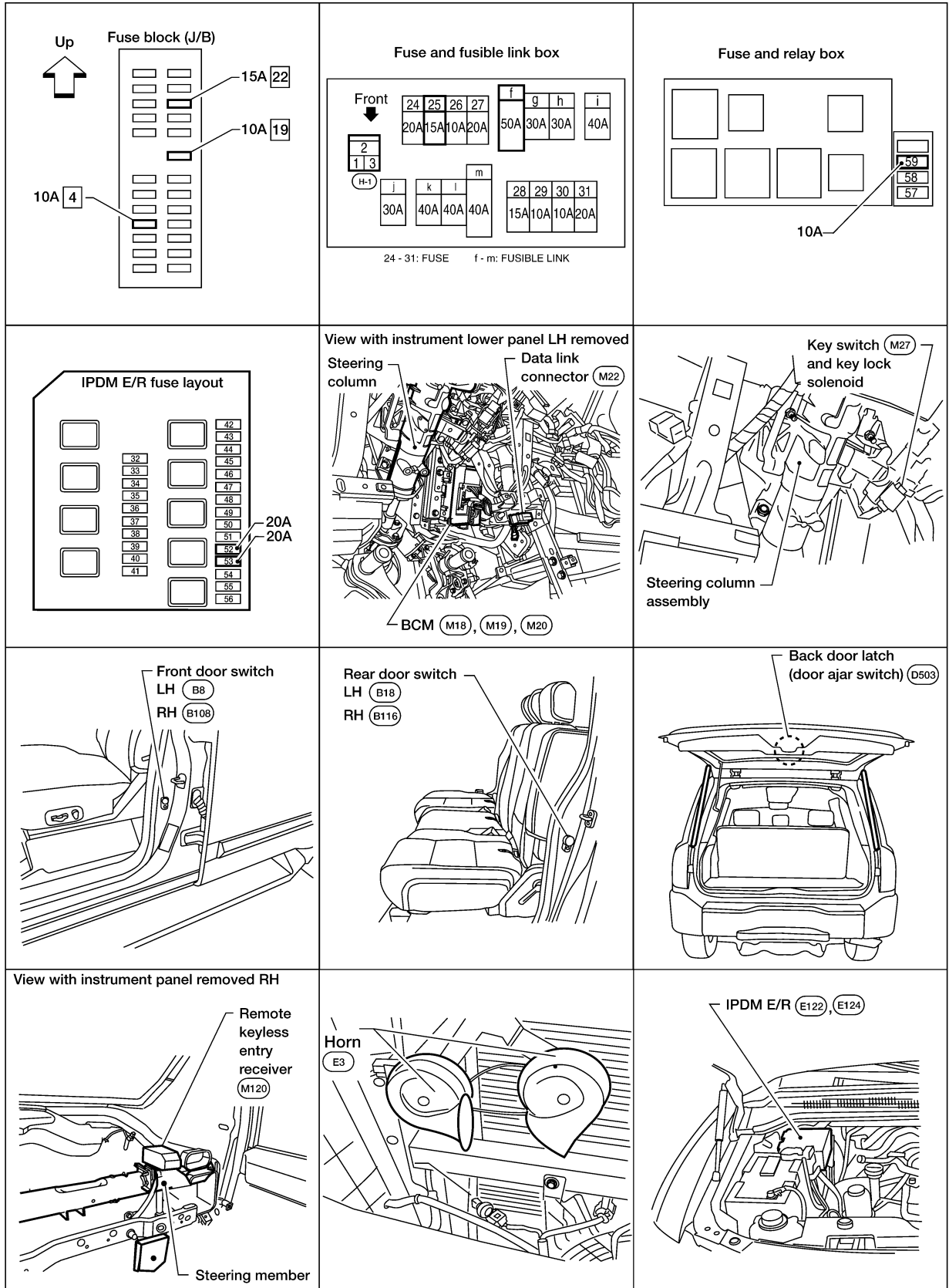

WIIA0588E

REMOTE KEYLESS ENTRY SYSTEM

EIS008PX

System Description

INPUTS

Power is supplied at all times

- to BCM terminal 70
- through 50A fusible link (letter f , located in the fuse and fusible link box).
- to BCM terminal 57
- through 15A fuse [No. 22, located in the fuse block (J/B)].

When the key is inserted in the key switch and key lock solenoid, power is supplied

- to BCM terminal 37
- through key switch and key lock solenoid terminals 3 and 4
- through 10A fuse [No. 19, located in the fuse block (J/B)].

When the ignition switch is ACC or ON, power is supplied

- to BCM terminal 11
- through 10A fuse [No. 4, located in the fuse block (J/B)].

When the ignition switch is ON or START, power is supplied

- to BCM terminal 38
- through 10A fuse (No. 59, located in the fuse and relay box).

When the front door switch LH is ON (door is OPEN), ground is supplied

- to BCM terminal 47
- through front door switch LH terminal 2
- through front door switch LH case ground.

When the front door switch RH is ON (door is OPEN), ground is supplied

- to BCM terminal 12
- through front door switch RH terminal 2
- through front door switch RH case ground.

When the rear door switch LH is ON (door is OPEN), ground is supplied

- to BCM terminal 48
- through rear door switch LH terminal 2
- through rear door switch LH case ground.

When the rear door switch RH is ON (door is OPEN), ground is supplied

- to BCM terminal 13
- through rear door switch RH terminal 2
- through rear door switch RH case ground.

When the back door latch (door ajar switch) is ON (door is OPEN), ground is supplied

- to BCM terminal 43
- through back door latch (door ajar switch) terminal 7,
- through back door latch (door ajar switch) terminal 8,
- through body grounds B7 and B19.

Keyfob signal is input into the BCM from the remote keyless entry receiver.

The remote keyless entry system controls operation of the

- power door lock
- back door opener
- interior lamp and step lamps
- panic alarm
- hazard and horn reminder
- keyless power window down (open)
- auto door lock operation

A

B

C

D

E

F

G

H

BL

J

K

L

M

REMOTE KEYLESS ENTRY SYSTEM

OPERATING PROCEDURE

- When the keyfob is operated, the signal from the keyfob is sent and the remote keyless entry receiver receives the signal and sends it to the BCM. The BCM only locks/unlocks the doors if the ID number matches. (Remote control entry functions)
- Using the keyfob, the transmitter sends radio waves to the remote keyless entry receiver, which then sends the received waves to the BCM. Only if the ID number matches does the BCM lock/unlock the doors. (Remote control door function)
- Unless the key is inserted into the ignition key cylinder or one of the doors is opened within 1 minute after the UNLOCK switch on the keyfob is pressed, all the doors are automatically locked. (Auto lock function)
- When a door is locked or unlocked, the vehicle turn signal lamps flash and the horn sounds to verify operation. (Active check function)
- When the key is in the ignition key cylinder (when the key switch is ON) and one of the doors is open, the door lock function does not work even when the door lock is operated with the keyfob.
- Keyfob ID set up is available.
- If a keyfob is lost, a new keyfob can be set up. A maximum of 5 IDs can be set up simultaneously.

Remote Control Entry Functions

Operation Description

- When a button on the keyfob is operated, the signal is sent from the keyfob and received by the remote keyless entry receiver.
- The received signal is sent to the BCM and compared with the registered ID number.
- If the ID number matches, the BCM sends the lock/unlock signal to each door lock actuator.
- When the door lock actuators receive this signal, each operates to lock/unlock its door.
- BCM locks all doors with input of LOCK signal from keyfob.
- When an UNLOCK signal is sent from keyfob once, driver's door will be unlocked.
- Then, if an UNLOCK signal is sent from keyfob again within 5 seconds, all other doors will be unlocked.

Remote control entry operation conditions

Keyfob operation	Operation condition
Door lock operation (locking)	<ul style="list-style-type: none">● With key removed (key switch: OFF)● Closing all doors (door switch: OFF)
Door lock operation (unlocking)	With key removed (key switch: OFF)

Auto Lock Function

Operation Description

- Unless the key is inserted into the ignition key cylinder, one of the doors is opened, or the keyfob is operated within 1 minute after a door lock is unlocked by keyfob operation, all the doors are automatically locked.
The 1 minute timer count is executed by the BCM and after 1 minute, the BCM sends the lock signal to all doors.
Lock operations are the same as for the remote control entry function.

Remote Control Automatic Back Door Function

Switching from all closed to all open

- When a button on the keyfob is operated, the signal is sent from the keyfob and received by the remote keyless entry receiver.
- The received signal is sent to the BCM and compared with the registered ID number.
- If the ID number matches, the BCM uses power window serial link communication to send the back door open signal to the back door control unit
- When the back door control unit receives the back door open signal for 0.5 seconds, if the remote control automatic back door operation enable conditions are met, the warning chime is sounded and the back door unlock signal is sent to the back door latch using communication.
- When the back door latch receives the back door unlock signal, it operates the release actuator and releases to back door latch.

REMOTE KEYLESS ENTRY SYSTEM

- The back door control unit operates the back door motor to open the back door. (At this time, speed control, input reverse, and overload reverse control are executed.)
- When the back door is opened to the fully open position, the full-open position is detected with the rotation sensor, the back door motor is stopped.
- The door held by the back door stays at the full open position.

Full open → full closed operation

- When a button of the keyfob is operated, the signal is sent from the keyfob and received by the remote keyless entry receiver.
- The received signal is sent to the BCM and compared with the registered ID number.
- If the ID number matches, the BCM uses power window serial link communication to send the back door close request signal to the back door control unit.
- When the back door control unit receives the back door close request signal for 0.5 seconds, if the remote control automatic back door operation enable conditions are met, the warning chime is sounded and the back door motor begins closing the back door.
- The back door control unit operates the magnetic clutch and the back door motor to close the back door. (At this time, the back door control unit executes speed control, input reverse, and overload reverse control.)
- When the back door comes to the half-latch state, the back door latch detects the half-latch state through half-latch switch operation. The back door latch latches the back door.

For the automatic back door system operation enable conditions, refer to [BL-99, "AUTOMATIC BACK DOOR SYSTEM"](#).

Active Check Function

Operation Description

When a door is locked or unlocked by keyfob operation, the vehicle turn signals flash and the horn sounds to verify operation.

- When a button on the keyfob is operated, the signal is sent from the remote controller and received by the keyless remote entry receiver.
- The received signal is sent to the BCM and compared with the registered ID number.
- If the ID number matches, the BCM sends the turn signal flashing and horn signal to the IPDM E/R.
- The IPDM E/R flashes the turn signal lamps and sounds the horn for each keyfob operation.

Operating function of hazard and horn reminder

	C mode		S mode	
	Lock	Unlock	Lock	Unlock
Keyfob operation	Lock	Unlock	Lock	Unlock
Hazard warning lamp flash	Twice	Once	Twice	—
Horn sound	Once	—	—	—

Hazard and Horn Reminder

BCM output to IPDM E/R for horn reminder signal as DATA LINE (CAN-H and CAN-L).

The hazard and horn reminder has C mode (horn chirp mode) and S mode (non-horn chirp mode).

How to change hazard and horn reminder mode

☑ With CONSULT-II

Hazard and horn reminder can be changed using "WORK SUPPORT" mode in "MULTI ANSWER BACK SET".

☒ Without CONSULT-II

Refer to Owner's Manual for instructions.

Interior Lamp Operation

When the following input signals are both supplied:

- all door switches are in the OFF position. (when all the doors are closed);
- interior lamp switch is in DOOR position.

Remote keyless entry system turns on interior lamp and ignition keyhole illumination (for 30 seconds) with input of UNLOCK signal from keyfob.

For detailed description, refer to [LT-131, "ROOM LAMP TIMER OPERATION"](#).

REMOTE KEYLESS ENTRY SYSTEM

Panic Alarm Operation

When key switch is OFF (when ignition key is not inserted in key cylinder), remote keyless entry system turns on and off horn and headlamp intermittently with input of PANIC ALARM signal from keyfob. The alarm automatically turns off after 25 seconds or when BCM receives any signal from keyfob.

Keyless Power Window Down (Open) Operation

When keyfob unlock switch is turned ON with ignition switch OFF, and the switch is detected to be ON continuously for more than 1 second, the driver's door and passenger's door power windows are simultaneously opened.

Power window is operated to open and the operation continues as long as the keyfob unlock switch is pressed.

CAN Communication System Description

EIS008PY

Refer to [LAN-5, "CAN COMMUNICATION"](#) .

REMOTE KEYLESS ENTRY SYSTEM

Schematic

EIS008PZ

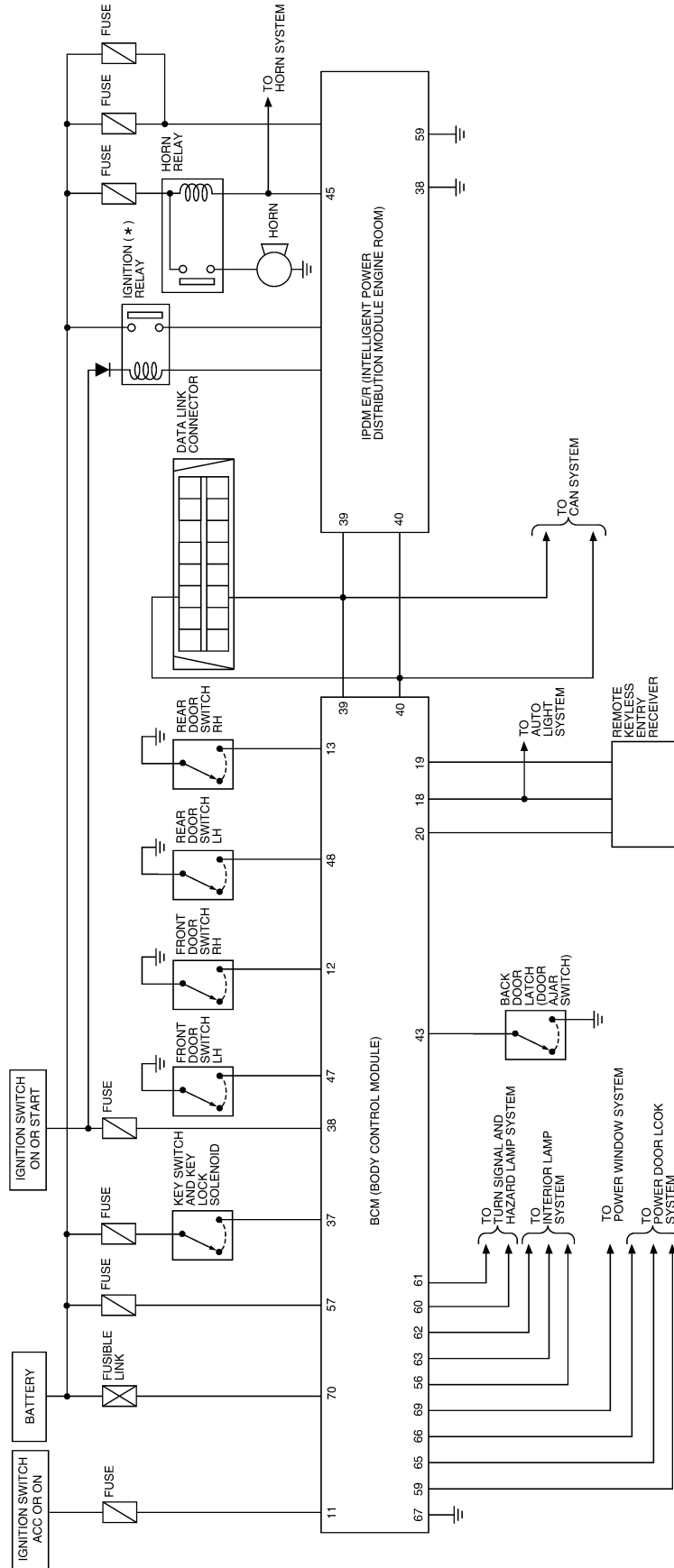

*: THIS RELAY IS BUILT INTO THE IPDM/ER (INTELLIGENT POWER DISTRIBUTION MODULE ENGINE ROOM).

A
B
C
D
E
F
G
H
I
J
K
L
M

BL

REMOTE KEYLESS ENTRY SYSTEM

Wiring Diagram — KEYLES —

EIS00800

BL-KEYLES-01

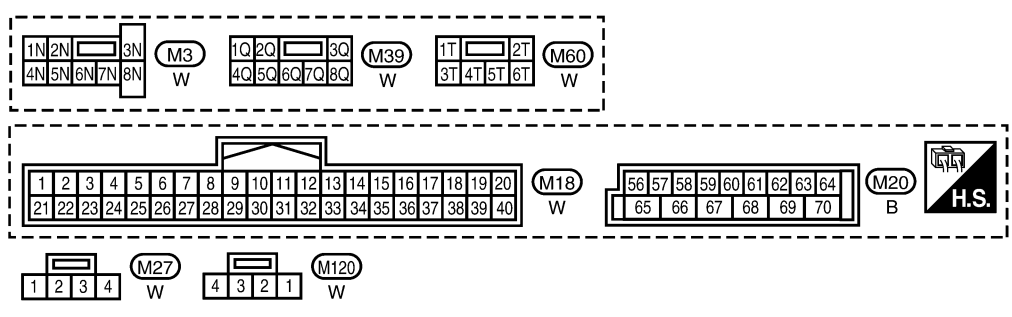
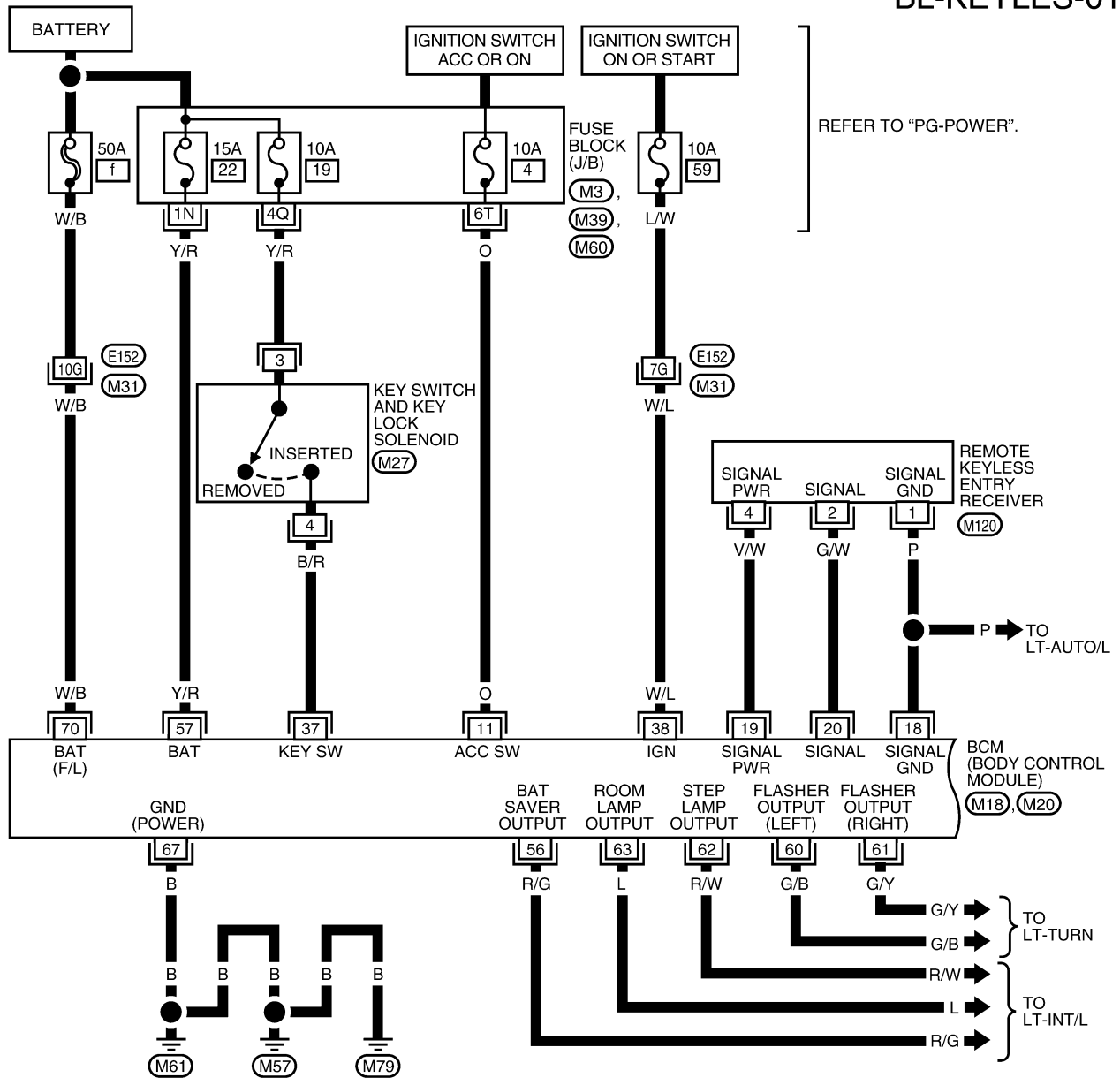

REFER TO THE FOLLOWING.
 (M31) - SUPER MULTIPLE JUNCTION (SMJ)

WIWA1308E

REMOTE KEYLESS ENTRY SYSTEM

BL-KEYLES-02

— : DATA LINE

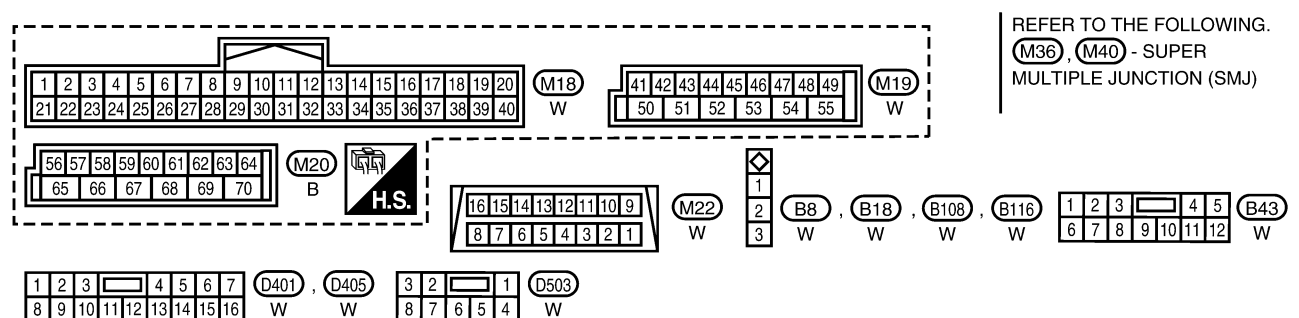
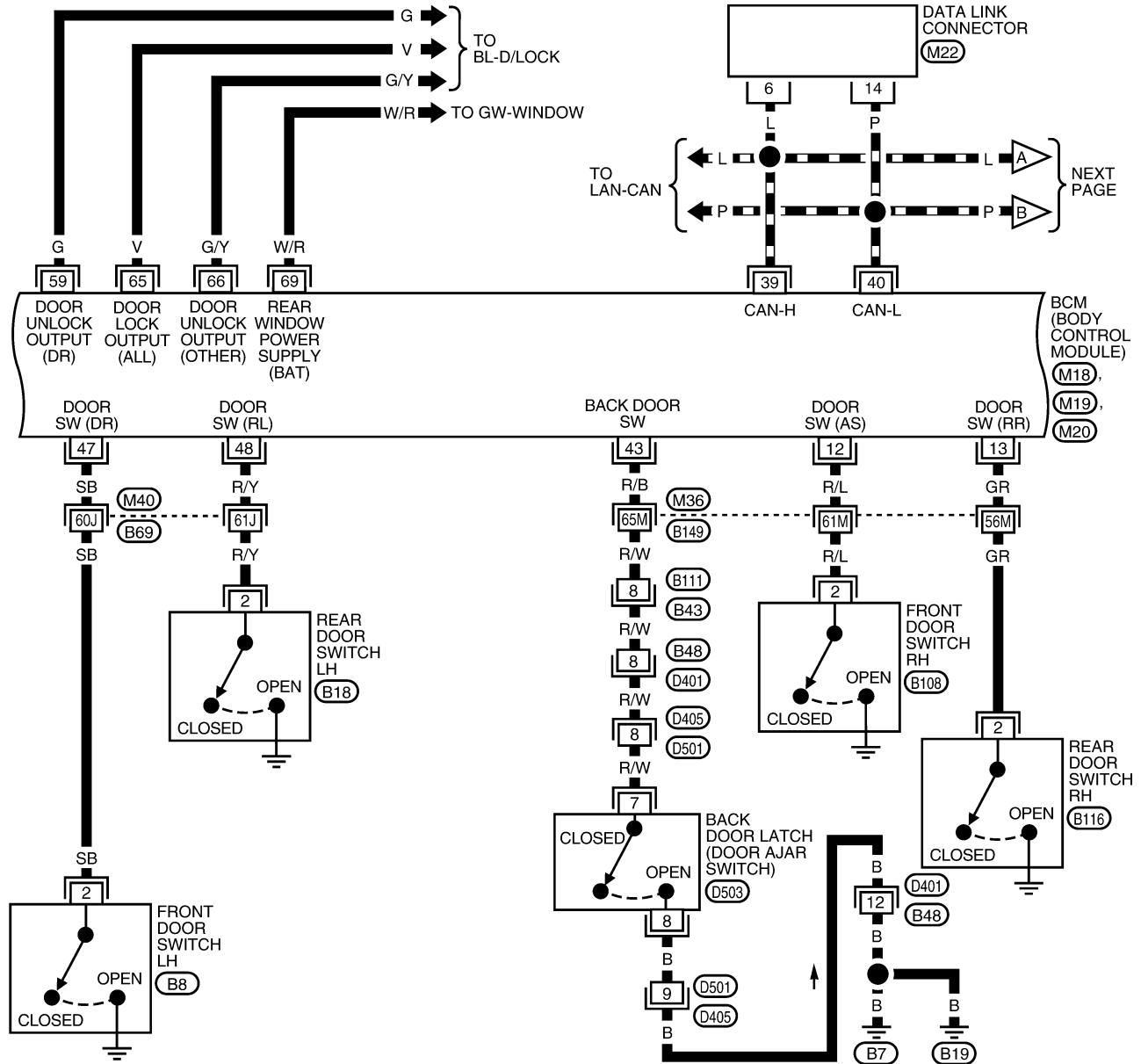

WIWA1309E

REMOTE KEYLESS ENTRY SYSTEM

BL-KEYLES-03

▬ : DATA LINE

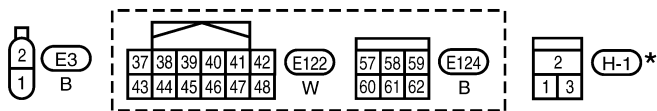
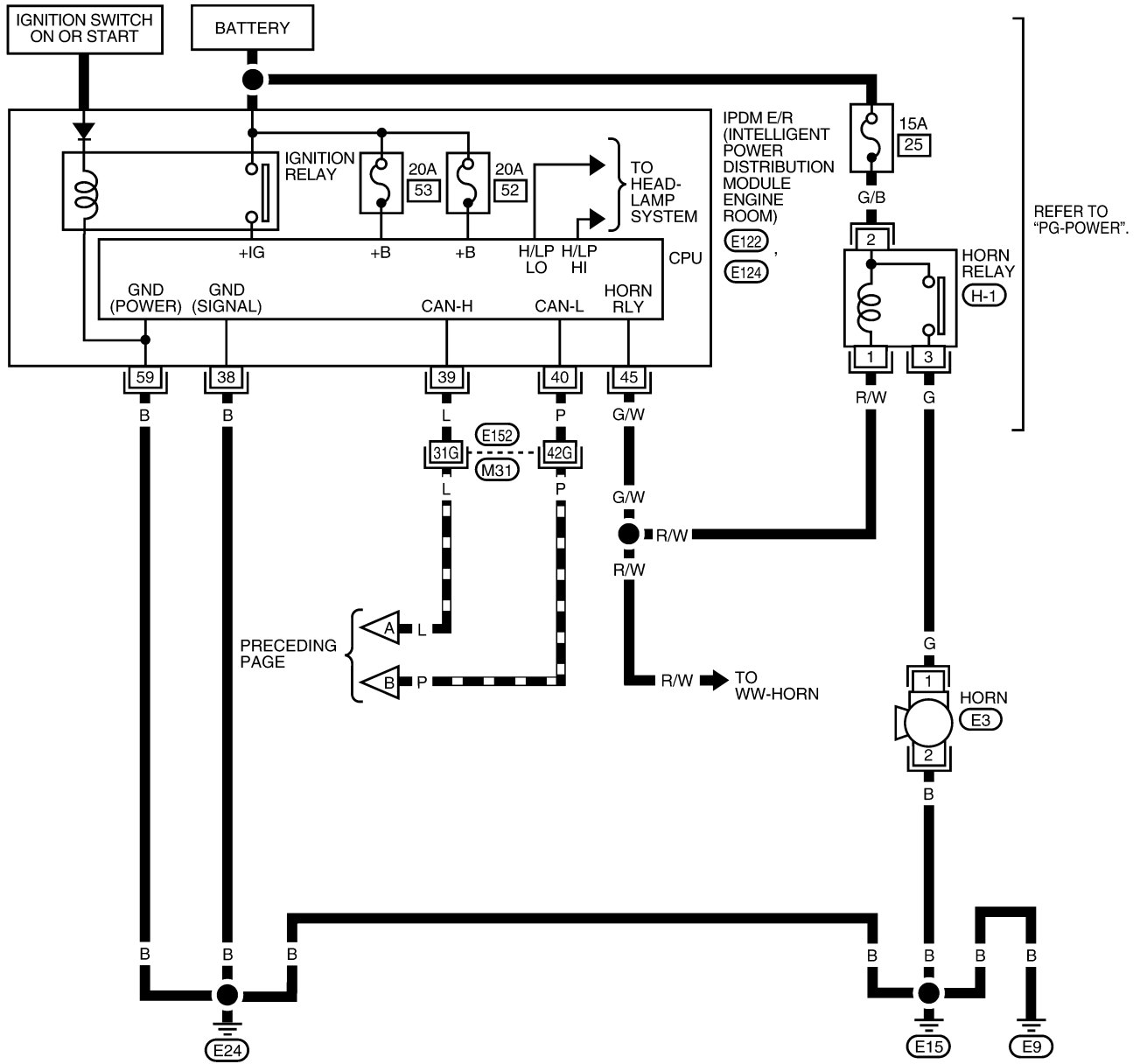

REFER TO THE FOLLOWING.
 (M31) - SUPER MULTIPLE JUNCTION (SMJ)

*: THIS CONNECTOR IS NOT SHOWN IN "HARNES LAYOUT" OF PG SECTION.

WIWA1310E

REMOTE KEYLESS ENTRY SYSTEM

Terminals and Reference Value for BCM

EIS008Q1

Terminal	Wire Color	Item	Condition	Voltage (V) (Approx.)
11	O	Ignition switch (ACC or ON)	Ignition switch (ACC or ON position)	Battery voltage
12	R/L	Front door switch RH	Door open (ON) → Door close (OFF)	Battery voltage → 0
13	GR	Rear door switch RH	Door open (ON) → Door close (OFF)	Battery voltage → 0
18	P	Remote keyless entry receiver ground	—	0
19	V/W	Remote keyless entry receiver (Power supply)	Ignition switch OFF	
			Stand-by (keyfob buttons released)	
20	G/W	Remote keyless entry receiver signal (Signal)	When remote keyless entry receiver receives signal from keyfob (keyfob buttons pressed)	
37	B/R	Key switch and key lock solenoid (insert)	Key inserted in IGN key cylinder (ON) → Key removed from IGN key cylinder (OFF)	Battery voltage → 0
38	W/L	Ignition switch (ON or START)	Ignition switch (ON or START position)	Battery voltage
39	L	CAN-H	—	—
40	P	CAN-L	—	—
43	R/B	Back door latch (door ajar switch)	Door open (ON) → Door close (OFF)	0 → Battery voltage
47	SB	Front door switch LH	Door open (ON) → Door close (OFF)	0 → Battery voltage
48	R/Y	Rear door switch LH	Door open (ON) → Door close (OFF)	0 → Battery voltage
56	R/G	Battery saver (Interior lamp)	Battery saver does operated → Does not operated (ON → OFF)	Battery voltage → 0
57	Y/R	Battery power supply	—	Battery voltage
59	G	Front door lock assembly LH (actuator) (unlock)	Door lock & unlock switch (Neutral → Unlock)	0 → Battery voltage
60	G/B	Turn signal LH	When doors are locked or unlocked using keyfob (OFF → ON) *2	0 → Battery voltage
61	G/Y	Turn signal RH	When doors are locked or unlocked using keyfob (OFF → ON) *2	0 → Battery voltage
62	R/W	Step lamp LH and RH	Step lamp ON	0
			Step lamp OFF	Battery voltage

A

B

C

D

E

F

G

H

BL

J

K

L

M

REMOTE KEYLESS ENTRY SYSTEM

Terminal	Wire Color	Item	Condition	Voltage (V) (Approx.)
63	L	Room lamp	Room lamp ON *1	Battery voltage
			Room Lamp OFF *1	0
65	V	All door lock actuators (lock)	Door lock & unlock switch (Neutral → Lock)	0 → Battery voltage
66	G/Y	Front door lock actuator RH, rear door lock actuators LH/RH and back door lock actuator (unlock)	Door lock & unlock switch (Neutral → Unlock)	0 → Battery voltage
67	B	Ground	—	0
69	W/R	Rear power window power supply	—	Battery voltage
70	W/B	Battery power supply	—	Battery voltage

- *1: when room lamp switch is in "DOOR" position.
- *2: when hazard reminder is ON.

Terminals and Reference Value for IPDM E/R

EIS008Q2

Terminal	Wire Color	Item	Condition	Voltage (V) (Approx.)
38	B	Ground	—	0
39	L	CAN-H	—	—
40	P	CAN-L	—	—
45	G/W	Horn relay	When doors locks are operated using keyfob (OFF → ON) *	Battery voltage → 0
59	B	Ground	—	0

*: when horn reminder is ON.

REMOTE KEYLESS ENTRY SYSTEM

CONSULT-II Function (BCM)

EIS008Q3

CONSULT-II can display each diagnostic item using the diagnostic test modes shown following.

BCM diagnostic test item	Diagnostic mode	Description
Inspection by part	WORK SUPPORT	Supports inspections and adjustments. Commands are transmitted to the BCM for setting the status suitable for required operation, input/output signals are received from the BCM and received date is displayed.
	DATA MONITOR	Displays BCM input/output data in real time.
	ACTIVE TEST	Operation of electrical loads can be checked by sending drive signal to them.
	SELF-DIAG RESULTS	Displays BCM self-diagnosis results.
	CAN DIAG SUPPORT MNTR	The result of transmit/receive diagnosis of CAN communication can be read.
	ECU PART NUMBER	BCM part number can be read.
	CONFIGURATION	Performs BCM configuration read/write functions.

CONSULT-II Inspection Procedure

EIS008Q4

CONSULT-II can display each diagnostic item using the following diagnostic test modes: work support, data monitor, active test, and CAN diagnostic support monitor through data reception and command transmission via the BCM communication line.

“MULTI REMOTE ENT”

CAUTION:

If CONSULT-II is used with no connection of CONSULT-II CONVERTER, malfunctions might be detected in self-diagnosis depending on control unit which carries out CAN communication.

1. Turn ignition switch OFF.
2. Connect CONSULT-II and CONSULT-II CONVERTER to the data link connector.

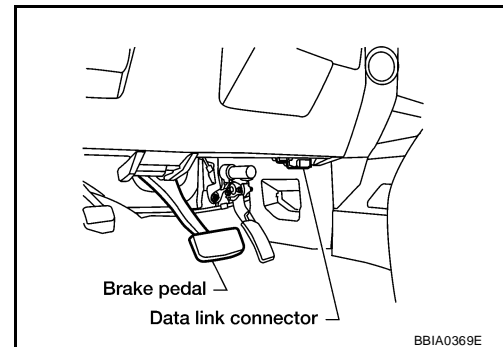

3. Turn ignition switch ON.
4. Touch “START (NISSAN BASED VHCL)”.

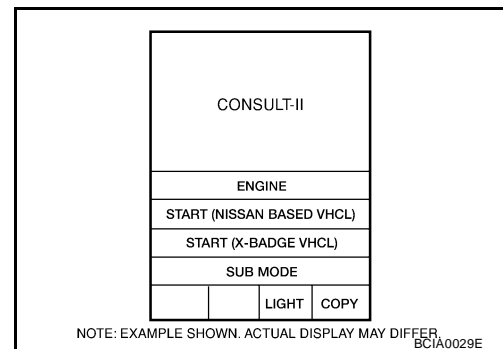

REMOTE KEYLESS ENTRY SYSTEM

5. Touch "BCM".
If "BCM" is not indicated, refer to [GI-39, "CONSULT-II Data Link Connector \(DLC\) Circuit"](#).

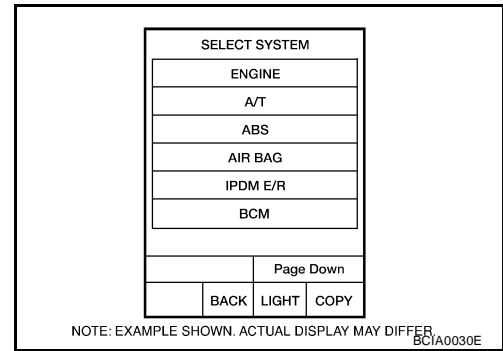

6. Touch "MULTI REMOTE ENT".

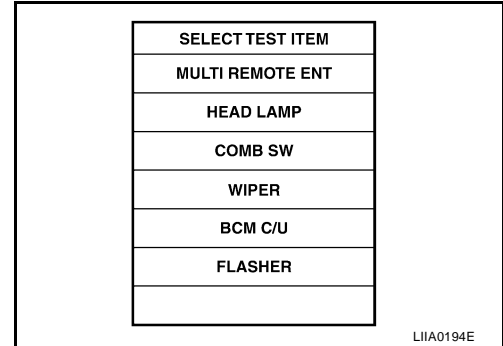

7. Select diagnosis mode.
"DATA MONITOR", "ACTIVE TEST" and "WORK SUPPORT" are available.

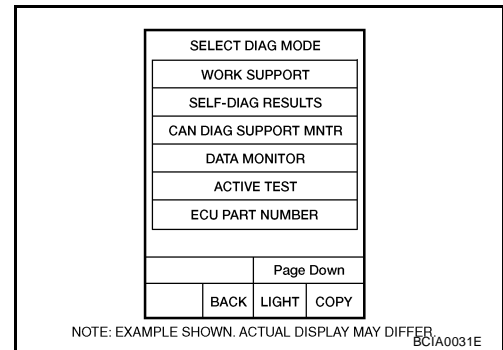

CONSULT-II Application Items "MULTI REMOTE ENT"

E/S008Q5

Data Monitor

Monitored Item	Description
DOOR SW-AS	Indicates [ON/OFF] condition of front door switch RH.
DOOR SW-RR	Indicates [ON/OFF] condition of rear door switch RH.
DOOR SW-RL	Indicates [ON/OFF] condition of rear door switch LH.
DOOR SW-DR	Indicates [ON/OFF] condition of front door switch LH.
BACK DOOR SW	Indicates [ON/OFF] condition of back door latch.
KEY ON SW	Indicates [ON/OFF] condition of key switch.
ACC ON SW	Indicates [ON/OFF] condition of ignition switch in ACC position.
IGN ON SW	Indicates [ON/OFF] condition of ignition switch in ON position.
KEYLESS PANIC	Indicates [ON/OFF] condition of panic signal from keyfob.
KEYLESS UNLOCK	Indicates [ON/OFF] condition of unlock signal from keyfob.
KEYLESS LOCK	Indicates [ON/OFF] condition of lock signal from keyfob.
KEY CYL LK-SW	Indicates [ON/OFF] condition of lock signal from door key cylinder switch.
KEY CYL UN-SW	Indicates [ON/OFF] condition of unlock signal from door key cylinder switch.
KEYLESS PBD	Indicates [ON/OFF] condition of power back door signal from keyfob.

REMOTE KEYLESS ENTRY SYSTEM

Monitored Item	Description
CDL UNLOCK SW	Indicates [ON/OFF] condition of unlock signal from lock/unlock switch.
CDL LOCK SW	Indicates [ON/OFF] condition of lock signal from lock/unlock switch.
DOOR SW-RL	Indicates [ON/OFF] condition of rear door switch LH.
DOOR SW-RR	Indicates [ON/OFF] condition of rear door switch RH.
RKE LCK-UNLCK	Indicates [ON/OFF] condition of lock/unlock signal at the same time from keyfob.
RKE KEEP UNLK	Indicates [ON/OFF] condition of unlock signal from keyfob.
TRNK OPN MNTR	Indicates [ON/OFF] condition of glass open switch.

Active Test

Test Item	Description
FLASHER	This test is able to check right and left hazard reminder operation. The right hazard lamp turns on when "RH" on CONSULT-II screen is touched and the left hazard lamp turns on when "LH" on CONSULT-II screen is touched.
POWER WINDOW DOWN	This test is able to check power window down operation. The windows are lowered when "ON" on CONSULT-II screen is touched.
HORN	This test is able to check panic alarm and horn reminder operations. The alarm activate for 0.5 seconds after "ON" on CONSULT-II screen is touched.
DOOR LOCK	This test is able to check door lock operation. The doors lock and unlock based on the item on CONSULT-II screen touched.
TRUNK/BACK DOOR	This test is able to check back door actuator operation. The back door is opened when "OPEN" on CONSULT-II screen is touched.
PSB/PBD OPEN TEST	This test is able to check power back door operation. The power back door is fully opened when "OPEN" on the CONSULT-II screen is touched if the door operation enable conditions are met.

Work Support

Test Item	Description
REMO CONT ID REGIST	Keyfob ID code can be registered.
REMO CONT ID ERASUR	Keyfob ID code can be erased.
REMO CONT ID CONFIR	It can be checked whether keyfob ID code is registered or not in this mode.
HORN CHIRP SET	Horn chirp function mode can be changed in this mode. The function mode will be changed when "CHANG SETT" on CONSULT-II screen is touched.
HAZARD LAMP SET	Hazard lamp function mode can be changed in this mode. The function mode will be changed when "CHANG SETT" on CONSULT-II screen is touched.
MULTI ANSWER BACK SET	Hazard and horn reminder mode can be changed in this mode. The reminder mode will be changed when "CHANG SETT" on CONSULT-II screen is touched.
AUTO LOCK SET	Auto locking function mode can be changed in this mode. The function mode will be changed when "CHANG SETT" on CONSULT-II screen is touched.
PANIC ALRM SET	Panic alarm operation mode can be changed in this mode. The operation mode will be changed when "CHANG SETT" on CONSULT-II screen is touched.
TRUNK OPEN SET	Back door opener operation mode can be changed in this mode. The operation mode will be changed when "CHANG SETT" on CONSULT-II screen is touched.
PW DOWN SET	Keyless power window down (open) operation mode can be changed in this mode. The operation mode will be changed when "CHANG SETT" on CONSULT-II screen is touched.

REMOTE KEYLESS ENTRY SYSTEM

Hazard and horn reminder mode

	MODE 1 (C mode)		MODE 2 (S mode)		MODE 3		MODE 4		MODE 5		MODE 6	
	Lock	Unlock	Lock	Unlock	Lock	Unlock	Lock	Unlock	Lock	Unlock	Lock	Unlock
Keyfob operation												
Hazard warning lamp flash	Twice	Once	Twice	—	—	—	Twice	Once	Twice	—	—	Once
Horn sound	Once	—	—	—	—	—	—	—	Once	—	Once	—

Auto locking function mode

	MODE 1	MODE 2	MODE 3
Auto locking function	5 minutes	Nothing	1 minute

Panic alarm operation mode

	MODE 1	MODE 2	MODE 3
Keyfob operation	0.5 seconds	Nothing	1.5 seconds

Back door open operation mode

	MODE 1	MODE 2	MODE 3
Keyfob operation	0.5 seconds	Nothing	0.5 seconds

Keyless power window down operation mode

	MODE 1	MODE 2	MODE 3
Keyfob operation	3 seconds	Nothing	5 seconds

REMOTE KEYLESS ENTRY SYSTEM

EIS00806

Trouble Diagnosis Procedure

1. Check the symptom and customer's requests.
2. Understand outline of system. Refer to [BL-45, "System Description"](#) .
3. Confirm system operation.
 - Check that the power door lock system operates normally. Refer to [BL-16, "POWER DOOR LOCK SYSTEM"](#) .
 - Check that the automatic back door system operates normally. Refer to [BL-99, "AUTOMATIC BACK DOOR SYSTEM"](#) .
4. Perform pre-diagnosis inspection. Refer to [BL-59, "BCM Power Supply and Ground Circuit Check"](#) .
5. Refer to trouble diagnosis chart by symptom, repair or replace any malfunctioning parts. Refer to [BL-60, "Trouble Diagnoses"](#) .
6. Inspection End.

BCM Power Supply and Ground Circuit Check

EIS00807

1. CHECK FUSE AND FUSIBLE LINK

Check the following BCM fuses and fusible link.

Component Parts	Terminal No. (SIGNAL)	Ampere	No.	Location
BCM	57 (BAT power supply)	15A	22	Fuse block (J/B)
	70 (BAT power supply)	50A	f	Fuse and fusible link box
	11 (ACC power supply)	10A	4	Fuse block (J/B)
	38 (IGN power supply)	10A	59	Fuse and relay box

NOTE:

Refer to [BL-44, "Component Parts and Harness Connector Location"](#) .

OK or NG

OK >> GO TO 2.

NG >> If fuse is blown, be sure to eliminate cause of problem before installing new fuse, refer to [PG-4, "POWER SUPPLY ROUTING CIRCUIT"](#) .

2. CHECK POWER SUPPLY CIRCUIT

1. Turn ignition switch OFF.
2. Disconnect BCM.
3. Check voltage between BCM connectors M18, M20 terminals 11, 38, 57, 70 and ground.

Connector	Terminals		Signal name	Ignition switch	Voltage
	(+)	(-)			
M20	70	Ground	Battery power supply	OFF	Battery voltage
	57		Battery power supply	OFF	Battery voltage
M18	11		ACC power supply	ACC	Battery voltage
	38		IGN power supply	ON	Battery voltage

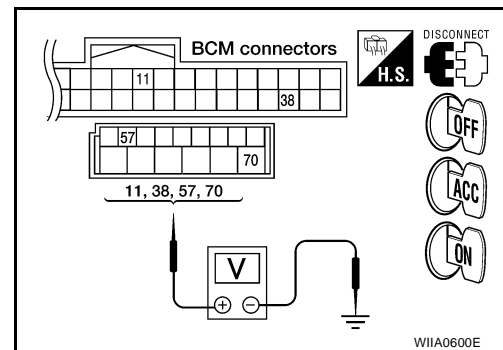

OK or NG

OK >> GO TO 3.

NG >> Repair or replace harness.

REMOTE KEYLESS ENTRY SYSTEM

3. CHECK GROUND CIRCUIT

Check continuity between BCM connector M20 terminal 67 and ground.

Connector	Terminals		Continuity
	(+)	(-)	
M20	67	Ground	Yes

OK or NG

- OK >> Power supply and ground circuit is OK.
- NG >> Repair or replace harness.

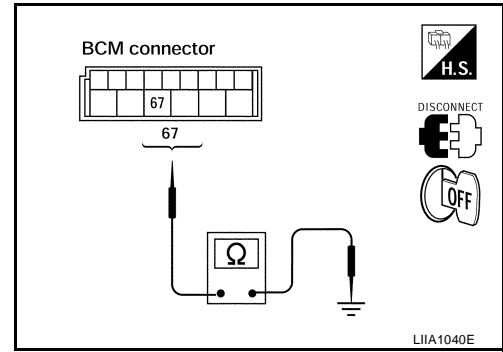

EIS008Q8

Trouble Diagnoses SYMPTOM CHART

NOTE:

- Always check the "Trouble Diagnosis Procedure" before troubleshooting. Refer to [BL-59, "Trouble Diagnosis Procedure"](#).
- Always check keyfob battery before replacing keyfob. Refer to [BL-65, "Keyfob Battery and Function Check"](#).
- The panic alarm operation and power back door opener operation of remote keyless entry system do not activate with the ignition key inserted in the ignition key cylinder.
- Use Remote Keyless Entry Tester J-43241 (follow instructions on tester) to check operation of keyfob before replacing keyfob.

Symptom	Diagnoses/service procedure	Reference page
All functions of remote keyless entry system do not operate.	1. Keyfob battery and function check (use Remote Keyless Entry Tester J-43241) NOTE: If the result of keyfob function check is OK, keyfob is not malfunctioning.	BL-65
	2. Check BCM and keyless receiver.	BL-66
The new ID of keyfob cannot be entered.	1. Keyfob battery and function check (use Remote Keyless Entry Tester J-43241) NOTE: If the result of keyfob function check is OK, keyfob is not malfunctioning.	BL-65
	2. Key switch and key lock solenoid (insert) check	BL-62
	3. Door switch check	BL-63
	4. ACC power check	BL-68
	5. Replace BCM.	BCS-20
Door lock or unlock does not function. (If the power door lock system does not operate manually, check power door lock system. Refer to BL-16, "POWER DOOR LOCK SYSTEM")	1. Keyfob battery and function check (use Remote Keyless Entry Tester J-43241) NOTE: If the result of keyfob function check is OK, keyfob is not malfunctioning.	BL-65
	2. Replace BCM.	BCS-20
Hazard and horn reminder does not activate properly when pressing lock or unlock button of keyfob.	1. Check hazard and horn reminder mode with CONSULT-II NOTE: Hazard and horn reminder mode can be changed. First check the hazard and horn reminder mode setting.	BL-57, "Active Test"
	2. Door switch check	BL-63
	3. Replace BCM.	BCS-20

REMOTE KEYLESS ENTRY SYSTEM

Symptom	Diagnoses/service procedure	Reference page	
Hazard reminder does not activate properly when pressing lock or unlock button of keyfob. (Horn reminder OK)	1. Check hazard reminder mode with CONSULT-II NOTE: Hazard reminder mode can be changed. First check the hazard reminder mode setting.	BL-57	A
	2. Check hazard function with hazard switch	—	B
	3. Replace BCM.	BCS-20	C
Horn reminder does not activate properly when pressing lock or unlock button of keyfob. (Hazard reminder OK)	1. Check horn reminder mode with CONSULT-II NOTE: Horn reminder mode can be changed. First check the horn reminder mode setting.	BL-57	D
	2. Check horn function with horn switch	—	E
	3. IPDM E/R operation check	BL-68	E
	4. Replace BCM.	BCS-20	E
Back door open/close operation is not carried out with keyfob operation. (The automatic back door system is normal.)	1. Keyfob battery and function check (use Remote Keyless Entry Tester J-43241) NOTE: If the result of keyfob function check is OK, keyfob is not malfunctioning.	BL-65	F
	2. Key switch (insert) check	BL-62	G
	3. Check that glass hatch is closed	—	H
	4. Remote keyless entry receiver system	BL-66	H
	5. Replace BCM.	BCS-20	H
Room lamp, ignition keyhole illumination and step lamp operation do not activate properly.	1. Room lamp operation check	BL-70	BL
	2. Ignition keyhole illumination operation check	BL-70	BL
	3. Step lamp operation check	LT-130	J
	4. Door switch check	BL-63	J
	5. Replace BCM.	BCS-20	J
Panic alarm (horn and headlamp) does not activate when panic alarm button is continuously pressed.	1. Keyfob battery and function check (use Remote Keyless Entry Tester J-43241) NOTE: If the result of keyfob function check is OK, keyfob is not malfunctioning.	BL-65	K
	2. Key switch and key lock solenoid (insert) check	BL-62	L
	3. Replace BCM.	BCS-20	M
Auto door lock operation does not activate properly. (All other remote keyless entry functions OK.)	1. Check auto door lock operation mode with CONSULT-II NOTE: Auto door lock operation mode can be changed. First check the auto door lock operation mode setting.	BL-57	
	2. Replace BCM.	BCS-20	
Keyless power window down (open) operation does not activate properly. (All other remote keyless entry functions OK.)	1. Check power window down operation mode with CONSULT-II NOTE: Power window down operation mode can be changed. First check the power window down operation mode setting.	BL-57	
	2. Check power window function with switch	—	
	3. Replace BCM.	BCS-20	

REMOTE KEYLESS ENTRY SYSTEM

EIS00809

Key Switch (Insert) Check

1. CHECK KEY SWITCH INPUT SIGNAL

 With CONSULT-II

Check key switch "KEY ON SW" in DATA MONITOR mode with CONSULT-II. Refer to [BL-27, "DATA MONITOR"](#).

- When key is inserted to ignition key cylinder:
KEY ON SW : ON
- When key is removed from ignition key cylinder:
KEY ON SW : OFF

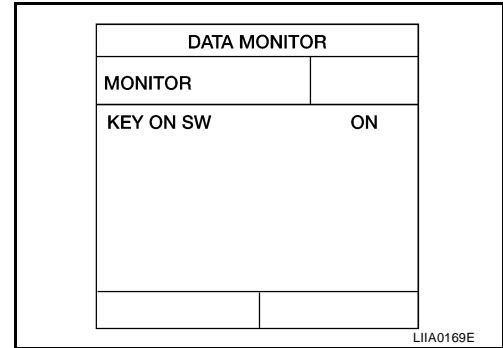

 Without CONSULT-II

Check voltage between BCM connector M18 terminal 37 and ground.

Connector	Terminals		Condition	Voltage (V)
	(+)	(-)		
M18	37	Ground	Key is inserted.	Battery voltage
			Key is removed.	0

OK or NG

- OK >> Key switch (insert) circuit is OK.
- NG >> GO TO 2.

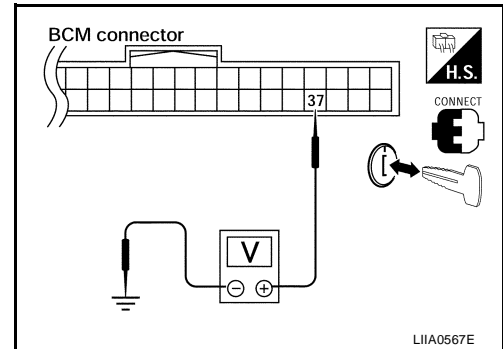

2. CHECK KEY SWITCH (INSERT)

- Turn ignition switch OFF.
- Disconnect key switch and key lock solenoid connector.
- Check continuity between key switch and key lock solenoid terminals 3, 4.

Terminals	Condition	Continuity
3 - 4	Key is inserted.	Yes
	Key is removed.	No

OK or NG

- OK >> Repair or replace harness.
- NG >> Replace key switch.

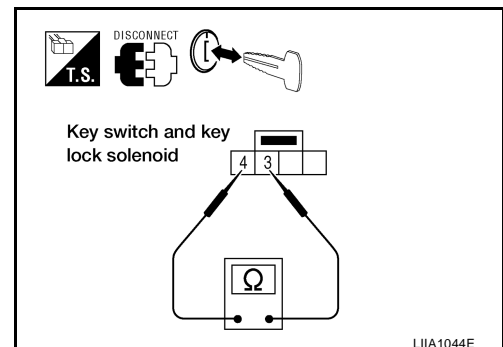

REMOTE KEYLESS ENTRY SYSTEM

EIS0080A

Door Switch Check

1. CHECK DOOR SWITCHES INPUT SIGNAL

 With CONSULT-II

Check door switches ("DOOR SW-DR", "DOOR SW-AS", "DOOR SW-RL", "DOOR SW-RR", "BACK DOOR SW") in DATA MONITOR mode with CONSULT-II. Refer to [BL-27, "DATA MONITOR"](#).

- When doors are open:

DOOR SW-DR : ON
DOOR SW-AS : ON
DOOR SW-RL : ON
DOOR SW-RR : ON
BACK DOOR SW : ON

- When doors are closed:

DOOR SW-DR : OFF
DOOR SW-AS : OFF
DOOR SW-RL : OFF
DOOR SW-RR : OFF
BACK DOOR SW : OFF

DATA MONITOR	
MONITOR	
DOOR SW - DR	OFF
DOOR SW - AS	OFF
DOOR SW - RR	OFF
DOOR SW - RL	OFF
BACK DOOR SW	OFF

LIA0665E

 Without CONSULT-II

Check voltage between BCM connector M18 or M19 terminals 12, 13, 43, 47, 48 and ground.

Connector	Item	Terminals		Condition	Voltage (V) (Approx.)
		(+)	(-)		
M19	Back door latch (door ajar switch)	43	Ground	Open ↓ Closed	0 ↓ Battery voltage
	Front door switch LH	47			
	Rear door switch LH	48			
M18	Front door switch RH	12	Ground	Open ↓ Closed	0 ↓ Battery voltage
	Rear door switch RH	13			

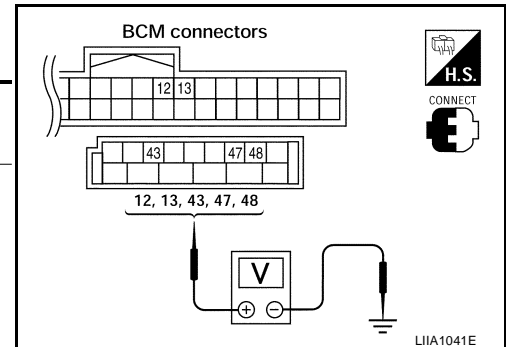

OK or NG

- OK >> Door switch circuit is OK.
- NG >> GO TO 2.

REMOTE KEYLESS ENTRY SYSTEM

2. CHECK DOOR SWITCH CIRCUIT

1. Turn ignition switch OFF.
2. Disconnect door switch and BCM.
3. Check continuity between door switch connector (B) B8 (front LH), B108 (front RH), B18 (rear LH), B116 (rear RH) terminal 2 or back door latch connector (C) D503 terminal 7 and BCM connectors (A) M18, M19 terminals 12, 13, 43, 47 and 48.

2 - 12 : Continuity should exist.
2 - 13 : Continuity should exist.
2 - 47 : Continuity should exist.
2 - 48 : Continuity should exist.
7 - 43 : Continuity should exist.

4. Check continuity between door switch connector (B) B8 (front LH), B108 (front RH), B18 (rear LH), B116 (rear RH) terminal 2 or back door latch connector (C) D503 terminal 7 and ground.

2 - Ground : Continuity should not exist.
7 - Ground : Continuity should not exist.

OK or NG

- OK >> GO TO 3.
 NG >> Repair or replace harness.

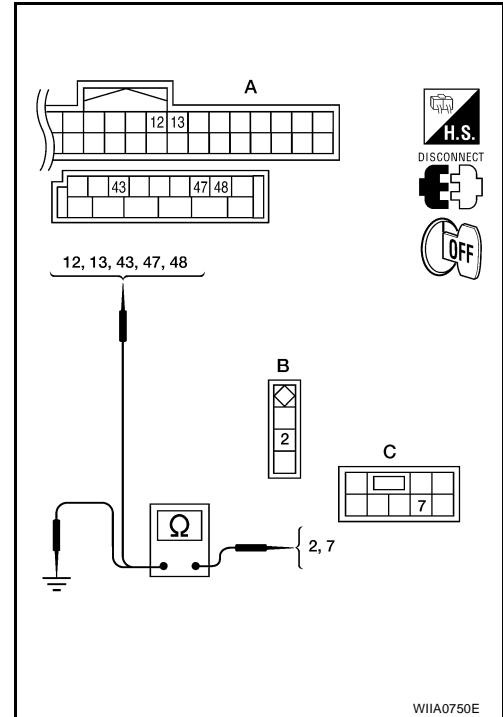

3. CHECK DOOR SWITCHES

FRONT AND REAR DOORS

Check continuity between front or rear door switch terminal 2 and exposed metal of switch while pressing and releasing switch.

Door switch is released : Continuity should exist.
Door switch is pushed : Continuity should not exist.

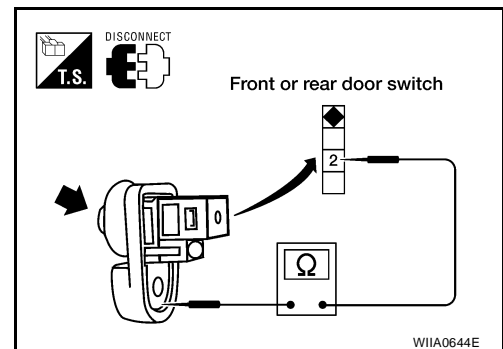

BACK DOOR

Check continuity between back door latch connector (A) D503 terminals 7 and 8 while pressing (closing back door) and releasing (opening back door) switch.

When back door is open : Continuity should exist.
When back door is closed : Continuity should not exist.

OK or NG

- OK >> (Front and rear doors) Switch circuit is OK.
 OK >> (Back door) GO TO 4.
 NG >> Replace door switch.

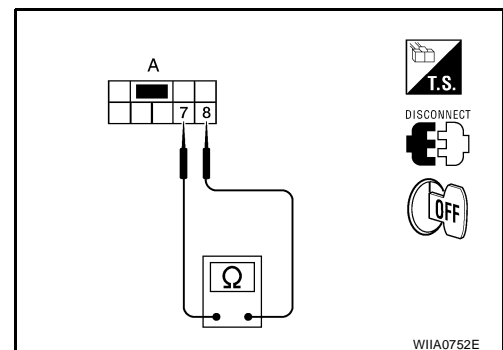

REMOTE KEYLESS ENTRY SYSTEM

4. CHECK BACK DOOR SWITCH GROUND

Check continuity between back door latch connector terminal 8 and ground.

8 - Ground : Continuity should exist.

OK or NG

- OK >> Back door switch circuit is OK.
- NG >> Repair or replace harness.

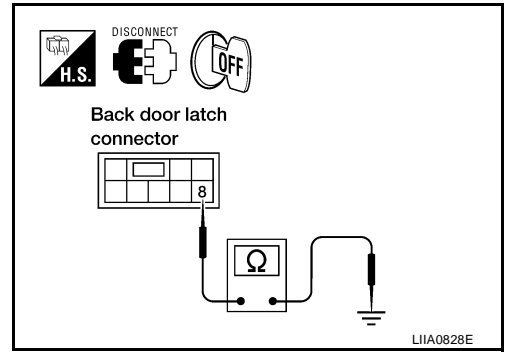

Keyfob Battery and Function Check

1. CHECK KEYFOB BATTERY

Remove battery and measure voltage across battery positive and negative terminals, (+) and (-).

Voltage : 2.5V - 3.0V

NOTE:

Keyfob does not function if battery is not set correctly.

OK or NG

- OK >> GO TO 2.
- NG >> Replace battery.

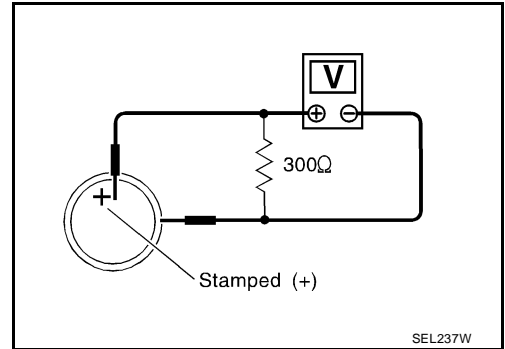

REMOTE KEYLESS ENTRY SYSTEM

2. CHECK KEYFOB FUNCTION

With CONSULT-II

Check keyfob function in "DATA MONITOR" mode with CONSULT-II. When pushing each button of keyfob, the corresponding monitor item should be turned as follows.

Condition	Monitor item
Pushing LOCK	KEYLESS LOCK : ON
Pushing UNLOCK	KEYLESS UNLOCK : ON
Keep pushing UNLOCK	RKE KEEP UNLK turns to ON 3 seconds after UNLOCK button is pushed.
Pushing PANIC	KEYLESS PANIC : ON
Pushing LOCK and UNLOCK at the same time	RKE LCK-UNLCK : ON
Pushing Power Back Door	KEYLESS PBD : ON

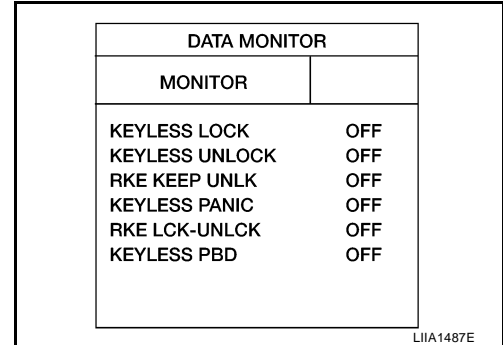

Without CONSULT-II

Check keyfob function using Remote Keyless Entry Tester J-43241.

OK or NG

- OK >> WITH CONSULT-II: Keyfob, remote keyless entry receiver and wiring harness between BCM and remote keyless entry receiver are OK. Replace BCM. Refer to [BCS-20, "Removal and Installation of BCM"](#).
- OK >> WITHOUT CONSULT-II: Keyfob is OK. Further inspection is necessary. Refer to [BL-60, "SYMPTOM CHART"](#).
- NG >> WITH CONSULT-II: Further inspection is necessary. Refer to [BL-60, "SYMPTOM CHART"](#).
- NG >> WITHOUT CONSULT-II: Replace keyfob. Refer to [BL-71, "ID Code Entry Procedure"](#).

Remote Keyless Entry Receiver System Check

EIS008QC

1. REMOTE KEYLESS ENTRY RECEIVER SIGNAL

Check signal voltage waveform between BCM connector M18 terminal 20 and ground using an oscilloscope.

Condition:

Keyfob buttons released : Refer to [BL-53, "Terminals and Reference Value for BCM"](#).

Keyfob buttons pressed : Refer to [BL-53, "Terminals and Reference Value for BCM"](#).

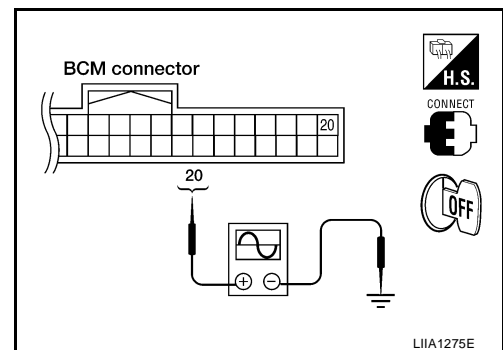

OK or NG

- OK >> Remote keyless entry receiver signal power supply, ground and signal circuits are OK. Replace BCM. Refer to [BCS-20, "Removal and Installation of BCM"](#).
- NG >> GO TO 2.

REMOTE KEYLESS ENTRY SYSTEM

2. REMOTE KEYLESS ENTRY RECEIVER POWER SUPPLY INSPECTION

Check signal voltage waveform between BCM connector M18 terminal 19 and ground using an oscilloscope.

19 - Ground

: Refer to [BL-53](#), "Terminals and Reference Value for BCM" .

OK or NG

OK >> GO TO 3.

NG >> Replace BCM. Refer to [BCS-20](#), "Removal and Installation of BCM" .

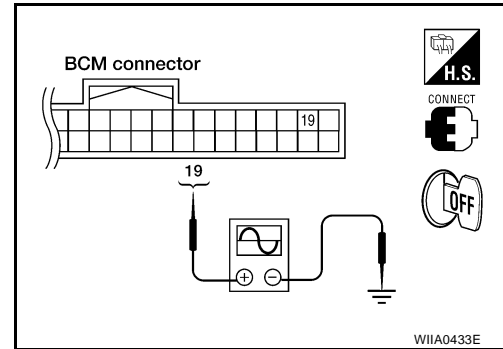

3. REMOTE KEYLESS ENTRY RECEIVER GROUND CIRCUIT INSPECTION (BCM)

Check continuity between BCM connector M18 terminal 18 and ground.

18 - Ground

: Continuity should exist.

OK or NG

OK >> GO TO 4.

NG >> Replace BCM. Refer to [BCS-20](#), "Removal and Installation of BCM" .

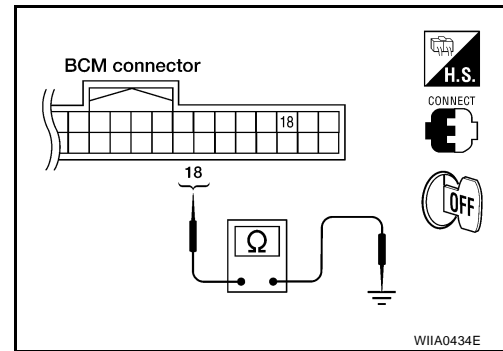

4. HARNESS INSPECTION BETWEEN BCM AND REMOTE KEYLESS ENTRY RECEIVER

1. Disconnect remote keyless entry receiver and BCM connectors.
2. Check continuity between remote keyless entry receiver connector M120 terminals 1, 2, 4 and BCM connector M18 terminals 18, 19, 20.

1 - 18 : Continuity should exist.

2 - 20 : Continuity should exist.

4 - 19 : Continuity should exist.

3. Check continuity between remote keyless entry receiver terminals 1, 2 and 4 and ground.

1 - Ground : Continuity should not exist.

2 - Ground : Continuity should not exist.

4 - Ground : Continuity should not exist.

OK or NG

OK >> Replace remote keyless entry receiver.

NG >> Repair or replace harness.

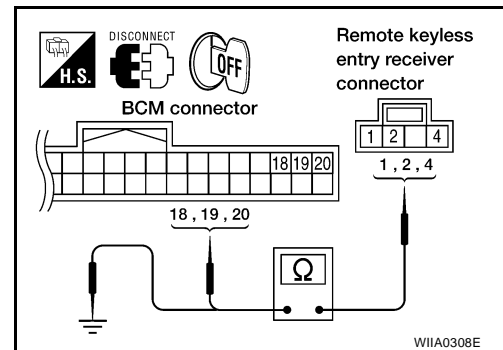

REMOTE KEYLESS ENTRY SYSTEM

EIS008QD

ACC Power Check

1. CHECK ACC POWER

 With CONSULT-II

Check "ACC ON SW" in DATA MONITOR mode with CONSULT-II. Refer to [BL-27, "DATA MONITOR"](#).

Monitor Item	Condition	
ACC ON SW	Ignition switch position ACC	: ON
	Ignition switch position OFF	: OFF

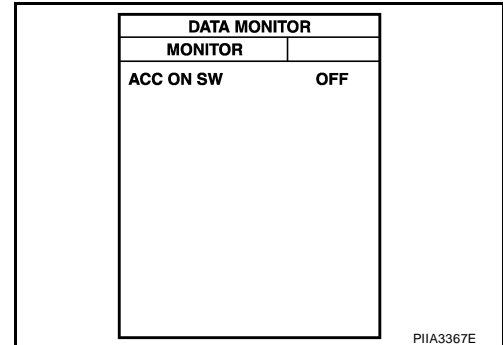

PIIA3367E

 Without CONSULT-II

Check voltage between BCM connector M18 terminal 11 and ground.

Connector	Terminals		Condition	Voltage (V) (Approx.)
	(+)	(-)		
M18	11	Ground	ACC	Battery voltage
			OFF	0

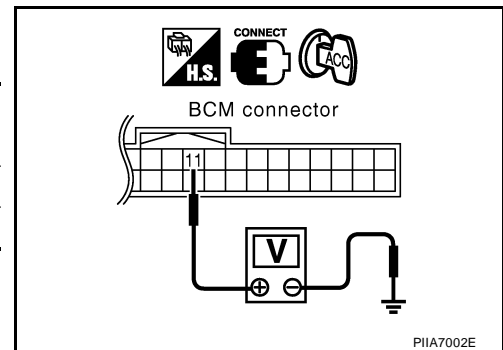

PIIA7002E

OK or NG

OK >> ACC power circuit is OK.

NG >> Check the following:

- 10A fuse [No. 4, located in fuse block (J/B)]
- Harness for open or short.

IPDM E/R Operation Check

1. CHECK IPDM E/R INPUT VOLTAGE

EIS008QE

Check voltage between IPDM E/R connector E122 terminal 45 and ground.

Connector	Terminals		Voltage (V) (Approx.)
	(+)	(-)	
E122	45	Ground	Battery voltage

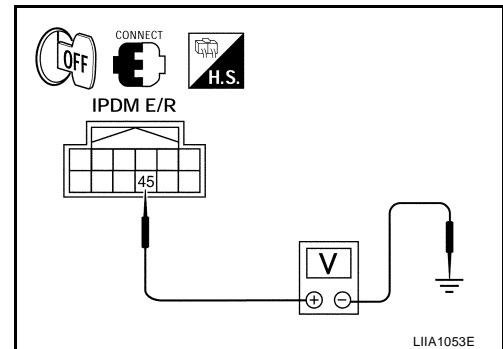

LIIA1053E

OK or NG

OK >> Replace IPDM E/R.

NG >> GO TO 2.

REMOTE KEYLESS ENTRY SYSTEM

2. CHECK IPDM E/R INPUT VOLTAGE

1. Turn ignition switch OFF.
2. Disconnect IPDM E/R and horn relay.
3. Check continuity between IPDM E/R connector E122 terminal 45 and horn relay connector H-1 terminal 1.

45 - 1 : Continuity should exist.

4. Check continuity between IPDM E/R connector E122 terminal 45 and ground.

45 - Ground : Continuity should not exist.

OK or NG

- OK >> Further inspection is necessary. Refer to [BL-60, "SYMP-TOM CHART"](#).
- NG >> Repair or replace harness

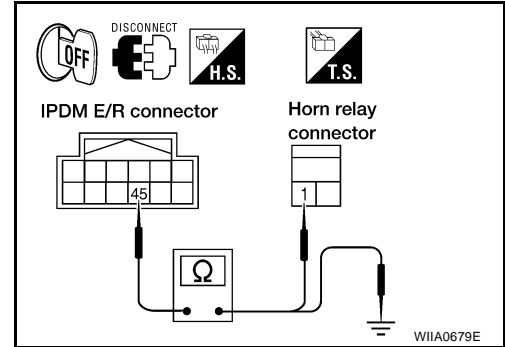

A
B
C
D
E
F
G
H
J
K
L
M

BL

REMOTE KEYLESS ENTRY SYSTEM

Check Hazard Function

EIS0080F

1. CHECK HAZARD WARNING LAMP

Does hazard indicator flash with hazard switch?

Yes or No

Yes >> Hazard warning lamp circuit is OK.

No >> Check hazard indicator. Refer to [LT-80, "TURN SIGNAL AND HAZARD WARNING LAMPS"](#) .

Check Horn Function

EIS0080G

First, perform the "SELF-DIAG RESULTS" in "BCM" with CONSULT-II, then perform the trouble diagnosis of malfunction system indicated in "SELF-DIAG RESULTS" of "BCM".

1. CHECK HORN FUNCTION

Does horn sound with horn switch?

Yes or No

Yes >> Horn circuit is OK.

No >> Check horn circuit. Refer to [WW-58, "HORN"](#) .

Check Headlamp Function

EIS0080H

First, perform the "SELF-DIAG RESULTS" in "BCM" with CONSULT-II, then perform the trouble diagnosis of malfunction system indicated in "SELF-DIAG RESULTS" of "BCM".

1. CHECK HEADLAMP OPERATION

Does headlamp come on when turning lighting switch ON?

Yes or No

Yes >> Headlamp operation circuit is OK.

No >> Check headlamp circuit. Refer to [LT-6, "HEADLAMP \(FOR USA\)"](#) .

Check Map Lamp Illumination Function

EIS0080I

1. CHECK MAP LAMP ILLUMINATION FUNCTION

When map lamp switch is in DOOR position, open the front door LH or RH.

Map lamp and ignition keyhole illumination should illuminate.

OK or NG

OK >> System is OK.

NG >> Check map lamp illumination circuit. Refer to [LT-152, "ILLUMINATION"](#) .

REMOTE KEYLESS ENTRY SYSTEM

EIS0080J

ID Code Entry Procedure KEYFOB ID SET UP WITH CONSULT-II

NOTE:

- If a keyfob is lost, the ID code of the lost keyfob must be erased to prevent unauthorized use. A specific ID code can be erased with CONSULT-II. However, when the ID code of a lost keyfob is not known, all controller ID codes should be erased. After all ID codes are erased, the ID codes of all remaining and/or new keyfobs must be re-registered.
- When registering an additional keyfob, the existing ID codes in memory may or may not be erased. If five ID codes are stored in memory when an additional code is registered, only the oldest code is erased. If less than five codes are stored in memory when an additional code is registered, the new ID code is added and no ID codes are erased.
- Entry of a maximum of five ID codes is allowed. When more than five codes are entered, the oldest ID code will be erased.
- Even if the same ID code that is already in memory is input, the same ID code can be entered. The code is counted as an additional code.

CAUTION:

If CONSULT-II is used with no connection of CONSULT-II CONVERTER, malfunctions might be detected in self-diagnosis depending on control unit which carries out CAN communication.

1. Turn ignition switch OFF.
2. Connect CONSULT-II and CONSULT-II CONVERTER to the data link connector.

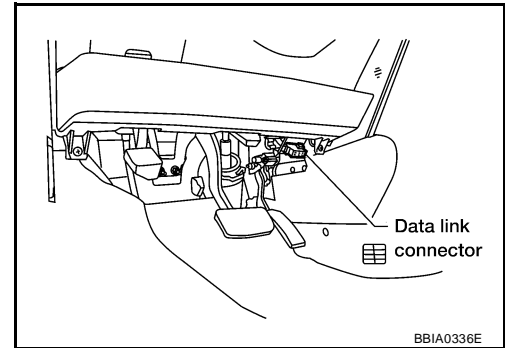

3. Turn ignition switch ON.
4. Touch "START (NISSAN BASED VHCL)".

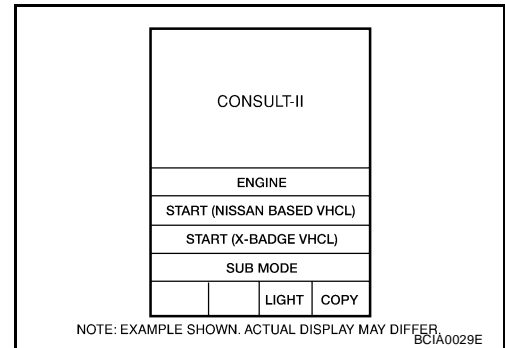

5. Touch "BCM".
If "BCM" is not indicated, refer to [GI-39, "CONSULT-II Data Link Connector \(DLC\) Circuit"](#).

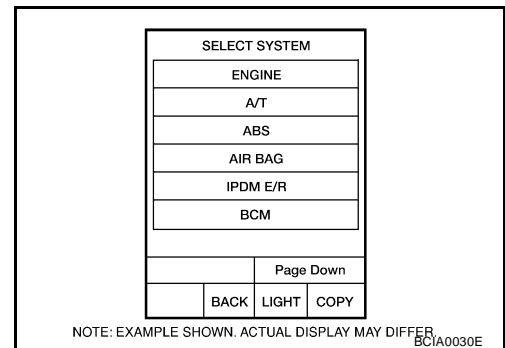

REMOTE KEYLESS ENTRY SYSTEM

6. Touch "MULTI REMOTE ENT".

SELECT TEST ITEM
MULTI REMOTE ENT
HEAD LAMP
COMB SW
WIPER
BCM C/U
FLASHER

LIAA0194E

7. Touch "WORK SUPPORT".

SELECT DIAG MODE
WORK SUPPORT
SELF-DIAG RESULTS
CAN DIAG SUPPORT MNTR
DATA MONITOR
ACTIVE TEST
ECU PART NUMBER
Page Down
BACK LIGHT COPY

NOTE: EXAMPLE SHOWN. ACTUAL DISPLAY MAY DIFFER. BCIA0031E

8. The items are shown on the figure can be set up.

- "REMO CONT ID REGIST"
Use this mode to register a keyfob ID code.

NOTE:

Register the ID code when keyfob or BCM is replaced, or when additional keyfob is required.

- "REMO CONT ID ERASUR"
Use this mode to erase a keyfob ID code.
- "REMO CONT ID CONFIR"
Use this mode to confirm if a keyfob ID code is registered or not.

SELECT WORK ITEM
REMO CONT ID REGIST
REMO CONT ID ERASUR
REMO CONT ID CONFIR
HORN CHIRP SET
HAZARD LAMP SET
MULTI ANSWER BACK SET

LIAA1147E

REMOTE KEYLESS ENTRY SYSTEM

KEYFOB ID SET UP WITHOUT CONSULT-II

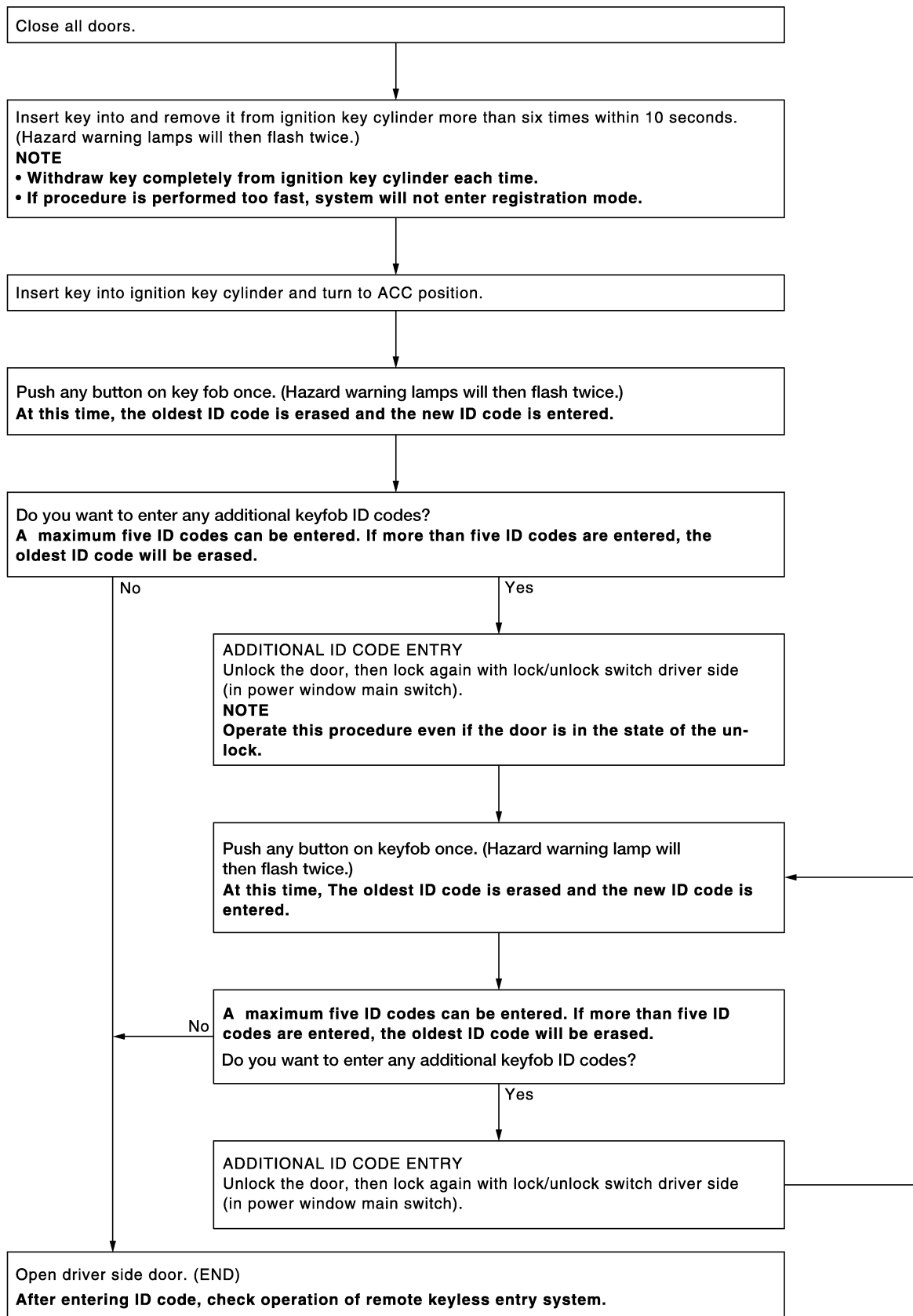

A

B

C

D

E

F

G

H

BL

J

K

L

M

LIIA1670E

REMOTE KEYLESS ENTRY SYSTEM

NOTE:

- If a keyfob is lost, the ID code of the lost keyfob must be erased to prevent unauthorized use. A specific ID code can be erased with CONSULT-II. However, when the ID code of a lost keyfob is not known, all controller ID codes should be erased. After all ID codes are erased, the ID codes of all remaining and/or new keyfobs must be re-registered.
To erase all ID codes in memory, register one ID code (keyfob) five times. After all ID codes are erased, the ID codes of all remaining and/or new keyfobs must be re-registered.
- When registering an additional keyfob, the existing ID codes in memory may or may not be erased. If five ID codes are stored in memory, when an additional code is registered, only the oldest code is erased. If less than five ID codes are stored in memory, when an additional ID code is registered, the new ID code is added and no ID codes are erased.
- If you need to activate more than two additional new keyfobs, repeat the procedure "Additional ID code entry" for each new keyfob.
- Entry of maximum five ID codes is allowed. When more than five ID codes are entered, the oldest ID code will be erased.
- Even if same ID code that is already in the memory is input, the same ID code can be entered. The code is counted as an additional code.

Keyfob Battery Replacement

EIS008QK

NOTE:

- Be careful not to touch the circuit board or battery terminal.
 - The keyfob is water-resistant. However, if it does get wet, immediately wipe it dry.
1. Open the lid using a coin.
 2. Remove the battery.
 3. Install the new battery, positive side down.
 4. Close the lid securely. Push the keyfob buttons two or three times to check operation.

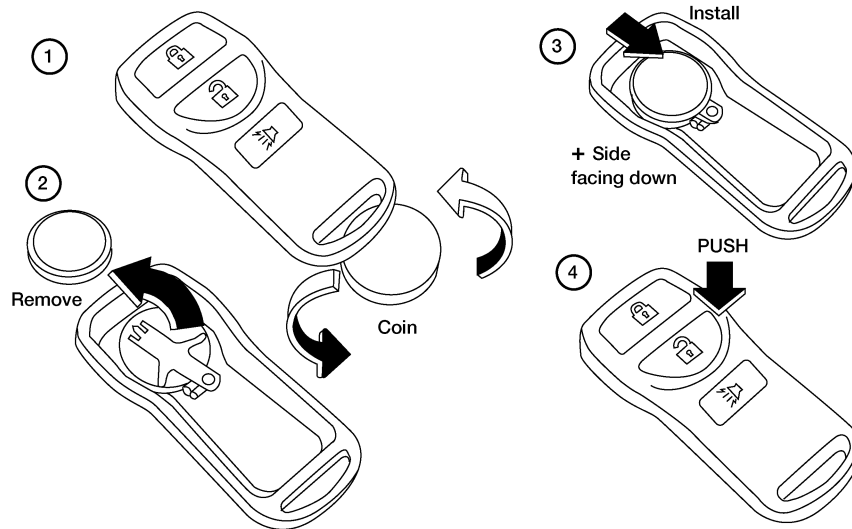

LIA1514E

VEHICLE SECURITY (THEFT WARNING) SYSTEM

VEHICLE SECURITY (THEFT WARNING) SYSTEM

PF28491

Component Parts and Harness Connector Location

EIS008QL

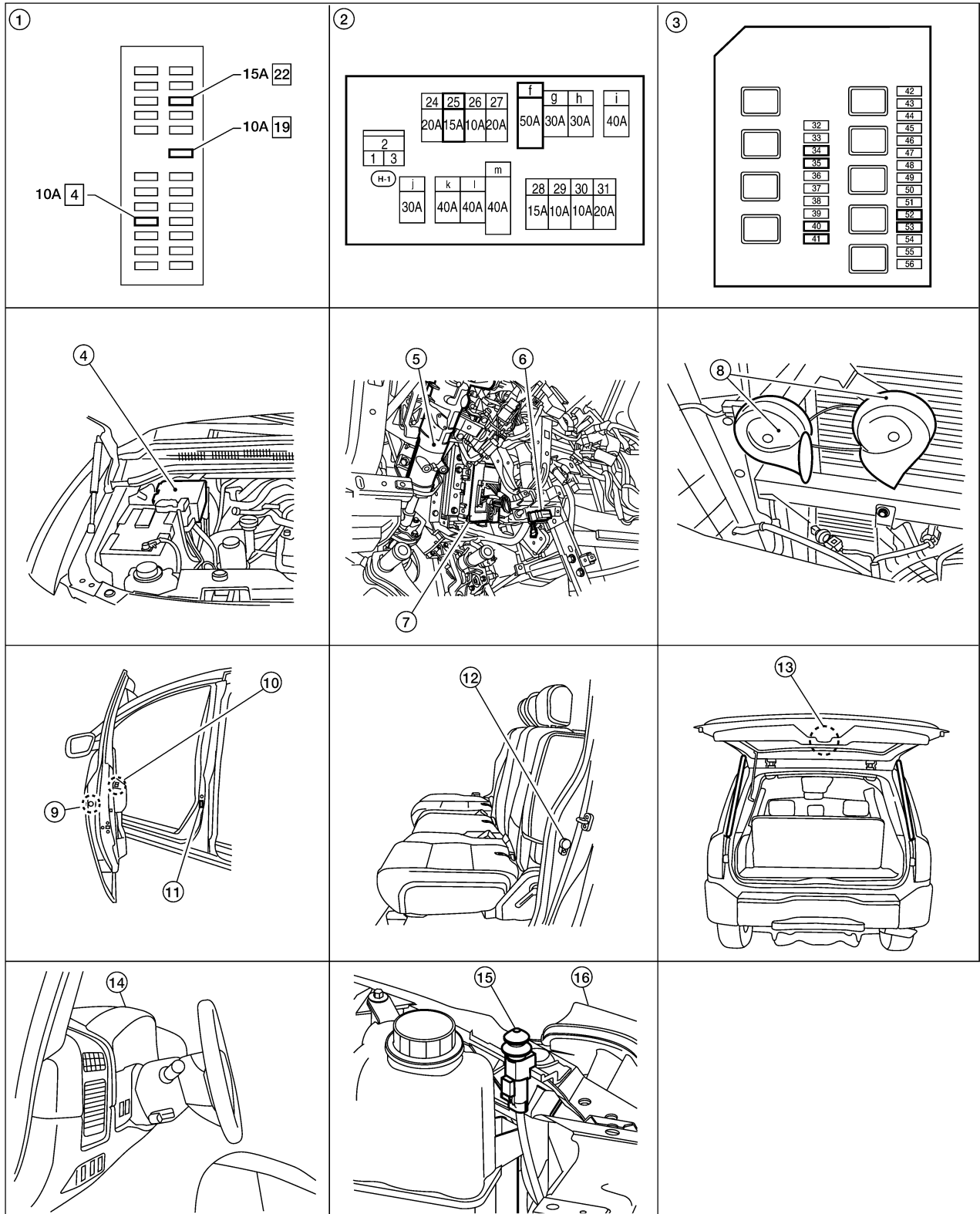

A
B
C
D
E
F
G
H
I
J
K
L
M

BL

- 1. Fuse block (J/B)
- 4. IPDM E/R E122, E123, E124

- 2. Fuse and fusible link box
- 5. Steering column
(view with instrument panel LH removed)

- 3. IPDM E/R fuse layout
- 6. Data link connector M22
(view with instrument panel LH removed)

LIA2374E

VEHICLE SECURITY (THEFT WARNING) SYSTEM

- | | | |
|--|---|--|
| 7. BCM M18, M19, M20
(view with instrument panel LH removed) | 8. Horn E3 | 9. Front door lock assembly LH (key cylinder switch) D14 |
| 10. Main power window and door lock/unlock switch D7, D8
Power window and door lock/unlock switch RH D105 | 11. Front door switch
LH B8
RH B108 | 12. Rear door switch
LH B18
RH B116 |
| 13. Back door latch (door ajar switch) D503
Glass hatch ajar switch D707 | 14. Combination meter M24 | 15. Hood switch E8 |
| 16. RH headlamp | | |

System Description

EIS008QM

DESCRIPTION

Operation Flow

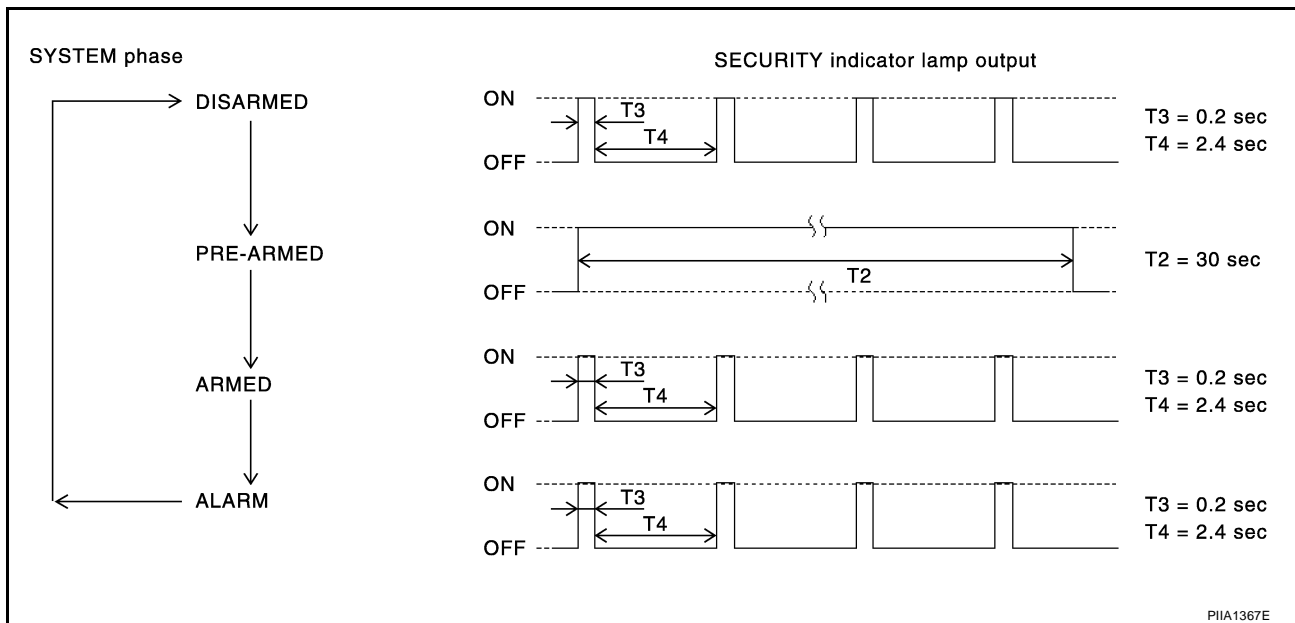

Setting the vehicle security system

Initial condition

- Ignition switch is in OFF position.

Disarmed phase

- When the vehicle is being driven or when doors or glass hatch is open, the vehicle security system is set in the disarmed phase on the assumption that the owner is inside or near the vehicle.

Pre-armed phase and armed phase

- The vehicle security system turns into the "pre-armed" phase when hood, glass hatch and all doors are closed and locked by keyfob. The security indicator lamp illuminates for 30 seconds, then the system automatically shifts into the "armed" phase.

Canceling the set vehicle security system

When one of the following operations is performed, the armed phase is canceled.

1. Unlock the doors with the key or the keyfob.
2. Open the power back door with the keyfob. When the power back door is closed after opening the power back door with the keyfob, the system returns to the armed phase.

Activating the alarm operation of the vehicle security system

Make sure the system is in the armed phase.

When one of the following operations is performed, the system sounds the horns and flashes the headlamps for about 50 seconds.

1. Engine hood, glass hatch or any door is opened before unlocking door with key or keyfob.

VEHICLE SECURITY (THEFT WARNING) SYSTEM

2. Door is unlocked without using key or keyfob.
3. Power back door is opened without using the keyfob.

A

POWER SUPPLY AND GROUND CIRCUIT

Power is supplied at all times

B

- through 10A fuse [No.19, located in the fuse block (J/B)]
- to combination meter (security indicator lamp) terminal 8 and
- through 50A fusible link (letter f , located in the fuse and fusible link box)
- to BCM terminal 70.
- through 15A fuse [No. 22, located in the fuse block (J/B)]
- to BCM terminal 57.
- through 15A fuse (No. 25, located in the fuse and fusible link box)
- to horn relay terminal 2.
- through 20A fuse (No. 52, located in the IPDM E/R) and
- through 20A fuse (No. 53, located in the IPDM E/R),
- to IPDM E/R internal CPU.

C

D

E

With the ignition switch in the ACC or ON position, power is supplied

- through 10A fuse [No. 4, located in the fuse block (J/B)]
- to BCM terminal 11.

F

G

Ground is supplied

- to BCM terminal 67
- through body grounds M57, M61 and M79 and
- to IPDM E/R terminals 38 and 59
- through body ground E9, E15 and E24.

H

BL

INITIAL CONDITION TO ACTIVATE THE SYSTEM

The operation of the vehicle security system is controlled by the doors, hood and glass hatch.

To activate the vehicle security system, BCM must receive signals indicating the doors, hood and glass hatch are closed and the doors are locked.

J

When a door is open, BCM terminal 12, 13, 42, 47 or 48 receives a ground signal from each door switch.

When front door LH is unlocked, BCM terminal 22 receives a signal from terminal 14 of main power window and door lock/unlock switch.

K

When front door RH is unlocked, BCM terminal 22 receives a signal from terminal 16 of power window and door lock/unlock switch RH or the rear power window switch LH or RH.

When the back door is open, BCM terminal 43 receives a ground signal

L

- from terminal 7 of the back door latch (door ajar switch)
- through back door latch terminal 8
- through body grounds B7 and B19.

M

When the glass hatch is open, BCM terminal 42 receives a ground signal

- from terminal + of the glass hatch ajar switch
- through glass hatch ajar switch case ground.

VEHICLE SECURITY SYSTEM ALARM OPERATION

The vehicle security system is triggered by

- opening a door
- opening the hood
- opening the glass hatch
- unlocking door without using the key or keyfob.

The vehicle security system will be triggered once the system is in armed phase,

- when BCM receives a ground signal at terminals 12, 13, 47, 48 (door switch), terminal 42 (glass hatch ajar switch) or terminal 43 [back door latch (door ajar switch)], or IPDM E/R terminal 41 (hood switch) receives a ground signal.

Power is supplied at all times

VEHICLE SECURITY (THEFT WARNING) SYSTEM

- to horn relay terminal 2
- through 15A fuse (No. 25, located in fuse and fusible link box).

When the vehicle security system is triggered, ground is supplied intermittently

- from IPDM E/R terminal 45
- to headlamp high relay and
- to horn relay terminal 1.

The headlamps flash and the horn sounds intermittently.

The alarm automatically turns off after 50 seconds, but will reactivate if the vehicle is tampered with again.

VEHICLE SECURITY SYSTEM DEACTIVATION

To deactivate the vehicle security system, a door must be unlocked with the key or keyfob.

When the key is used to unlock the front door LH, BCM terminal 22 receives signal

- from terminal 14 of the main power window and door lock/unlock switch.

When the BCM receives this signal or unlock signal from keyfob, the vehicle security system is deactivated. (Disarmed phase)

PANIC ALARM OPERATION

Remote keyless entry system may or may not operate vehicle security system (horn and headlamps) as required.

When the remote keyless entry system is triggered, ground is supplied intermittently

- from IPDM E/R terminal 45
- to headlamp high relay and
- to horn relay terminal 1.

The headlamp flashes and the horn sounds intermittently.

The alarm automatically turns off after 25 seconds or when BCM receives any signal from keyfob.

CAN Communication System Description

EIS008QN

Refer to [LAN-5, "CAN COMMUNICATION"](#) .

VEHICLE SECURITY (THEFT WARNING) SYSTEM

Schematic

EIS008QO

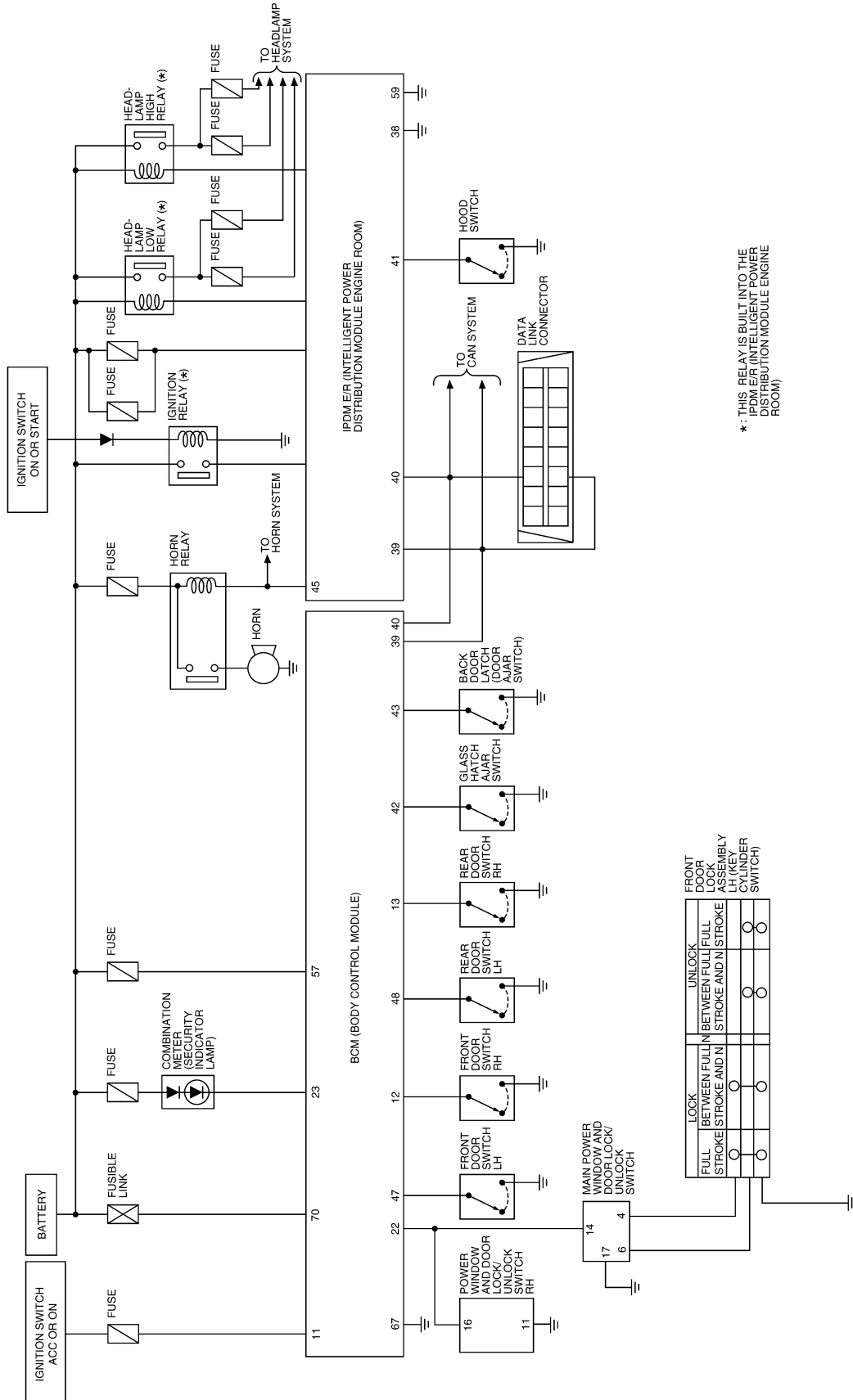

A
B
C
D
E
F
G
H
I
J
K
L
M

BL

VEHICLE SECURITY (THEFT WARNING) SYSTEM

Wiring Diagram — VEHSEC —

EIS008QP

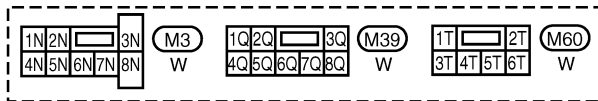
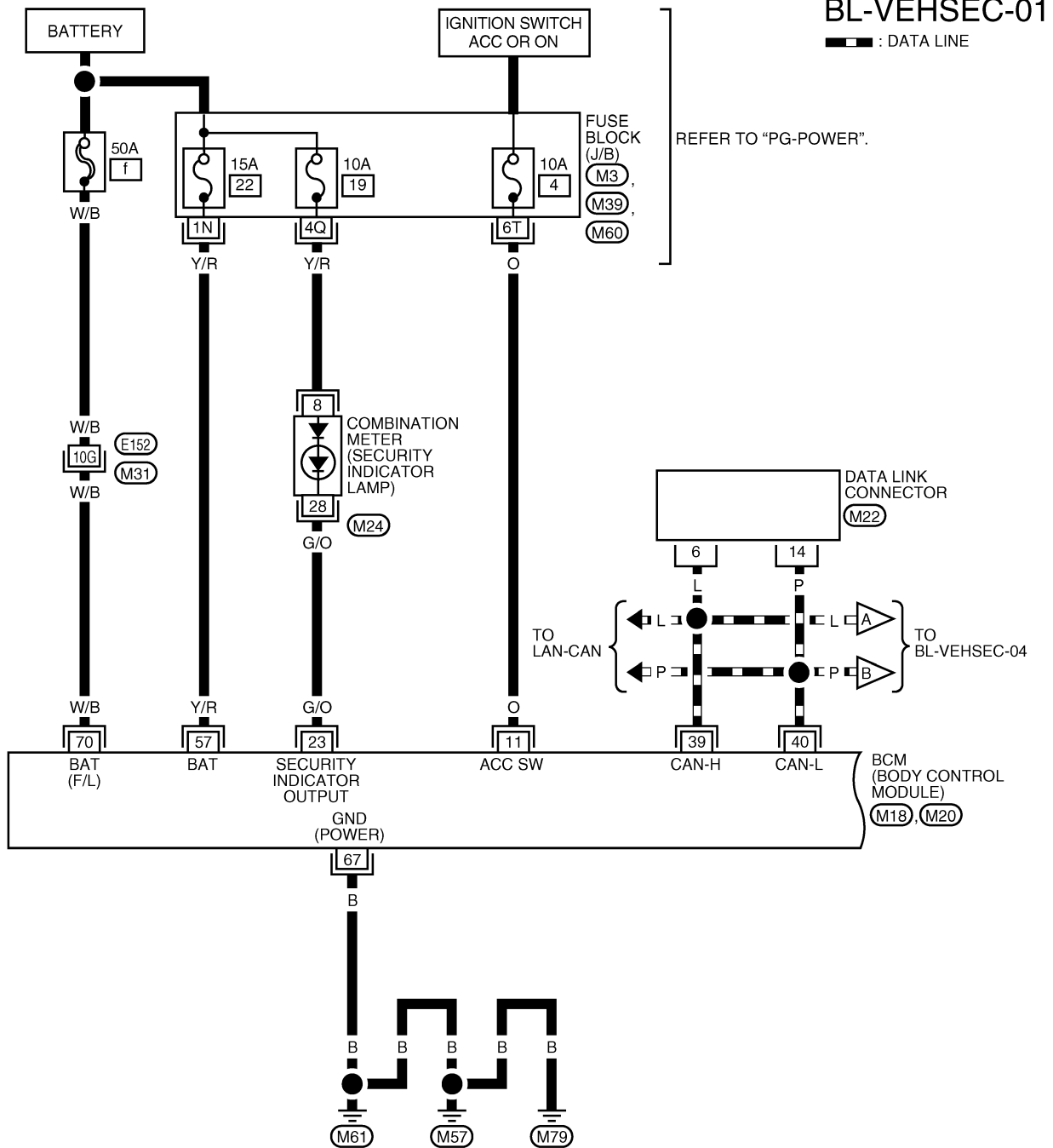

REFER TO THE FOLLOWING.
 M31 - SUPER MULTIPLE JUNCTION (SMJ)

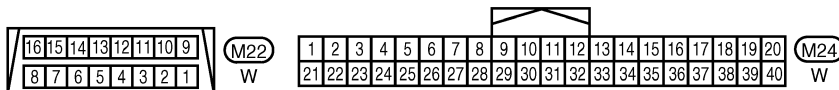
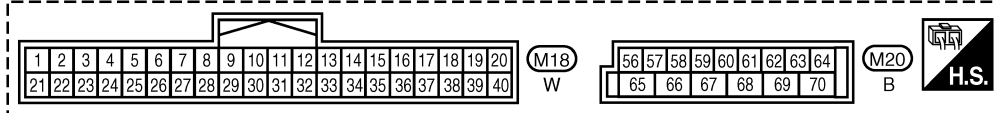

WIWA1227E

VEHICLE SECURITY (THEFT WARNING) SYSTEM

BL-VEHSEC-02

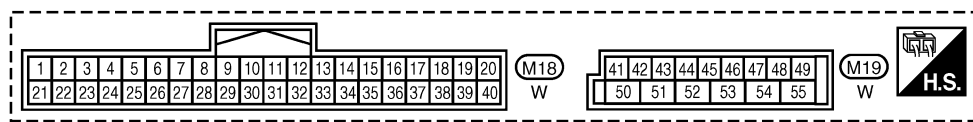
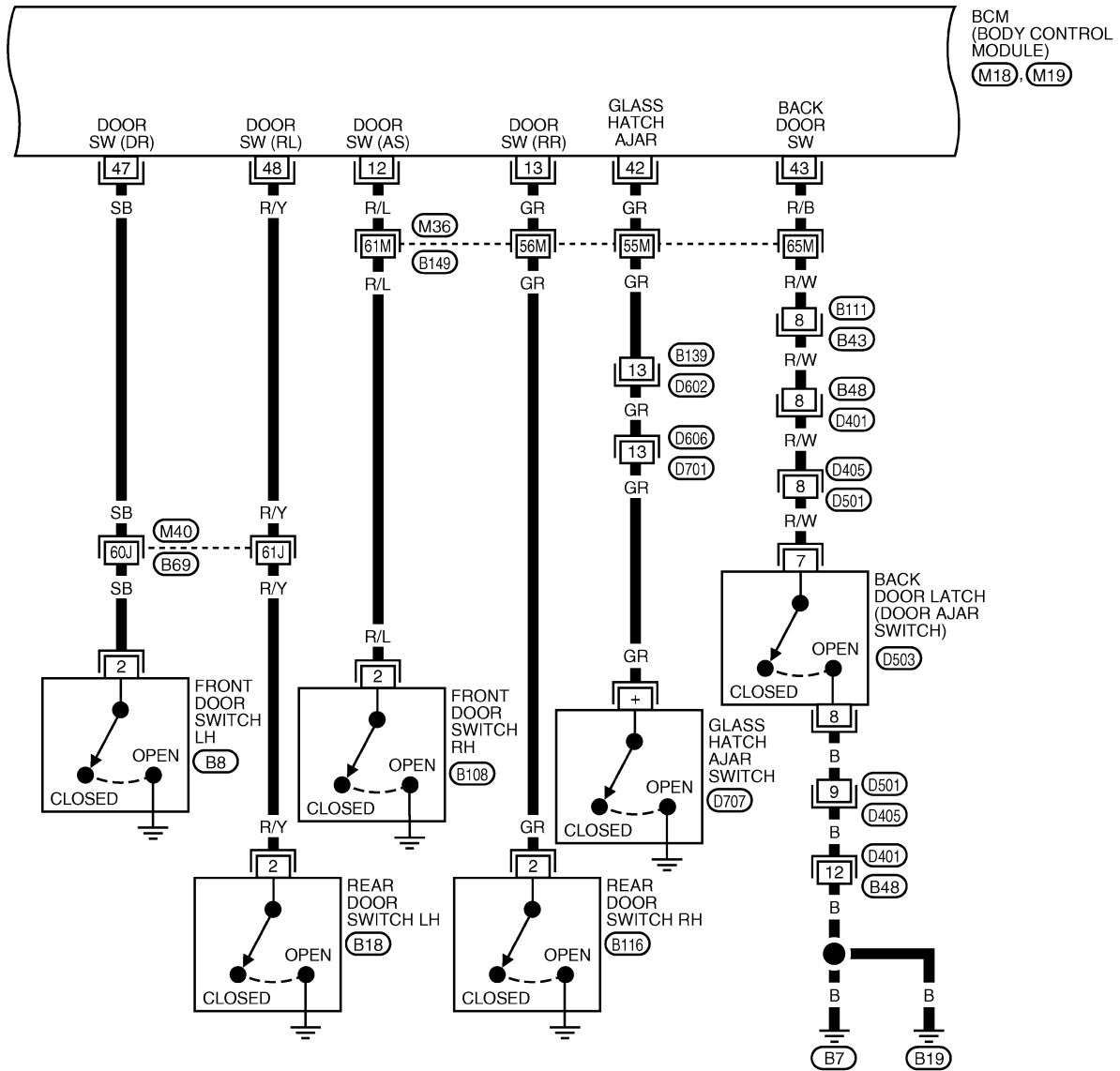

REFER TO THE FOLLOWING.
M36, M40 - SUPER MULTIPLE JUNCTION (SMJ)

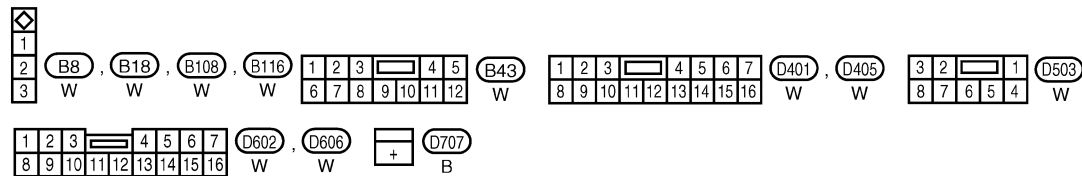

LIWA0458E

VEHICLE SECURITY (THEFT WARNING) SYSTEM

BL-VEHSEC-03

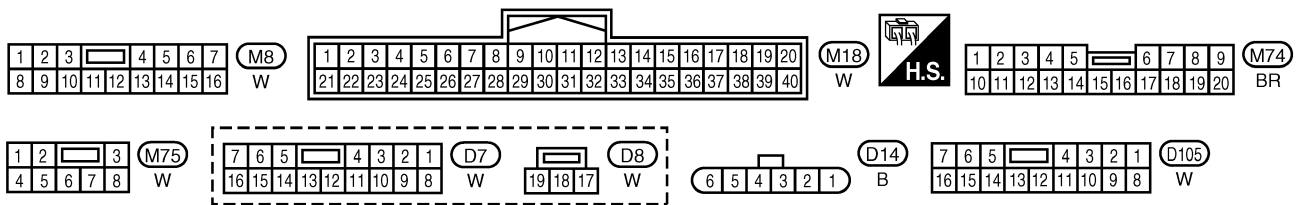
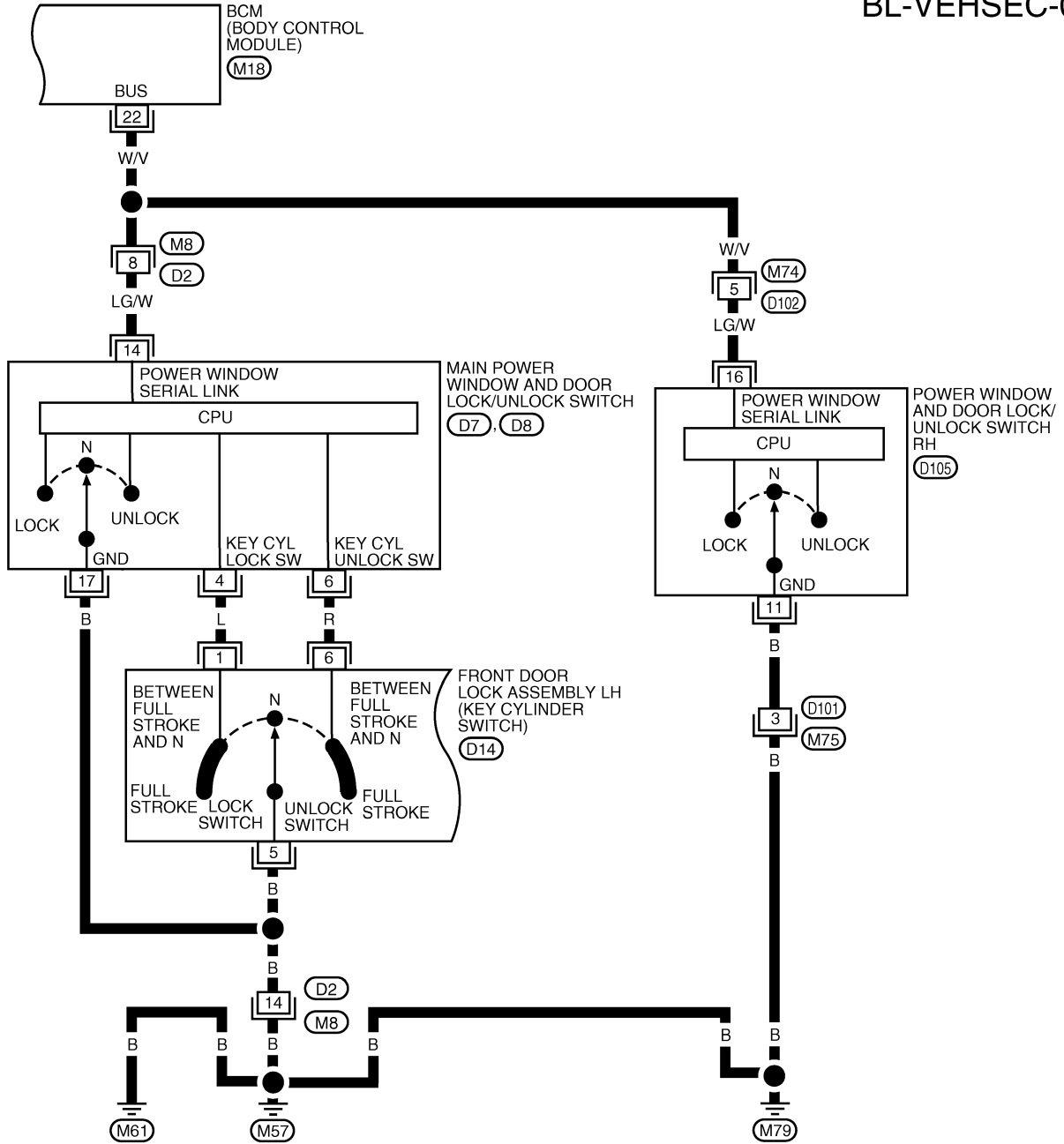

WIWA1229E

VEHICLE SECURITY (THEFT WARNING) SYSTEM

▬ : DATA LINE

BL-VEHSEC-04

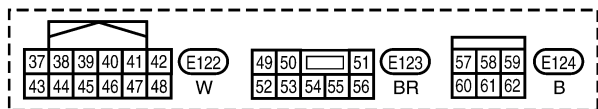
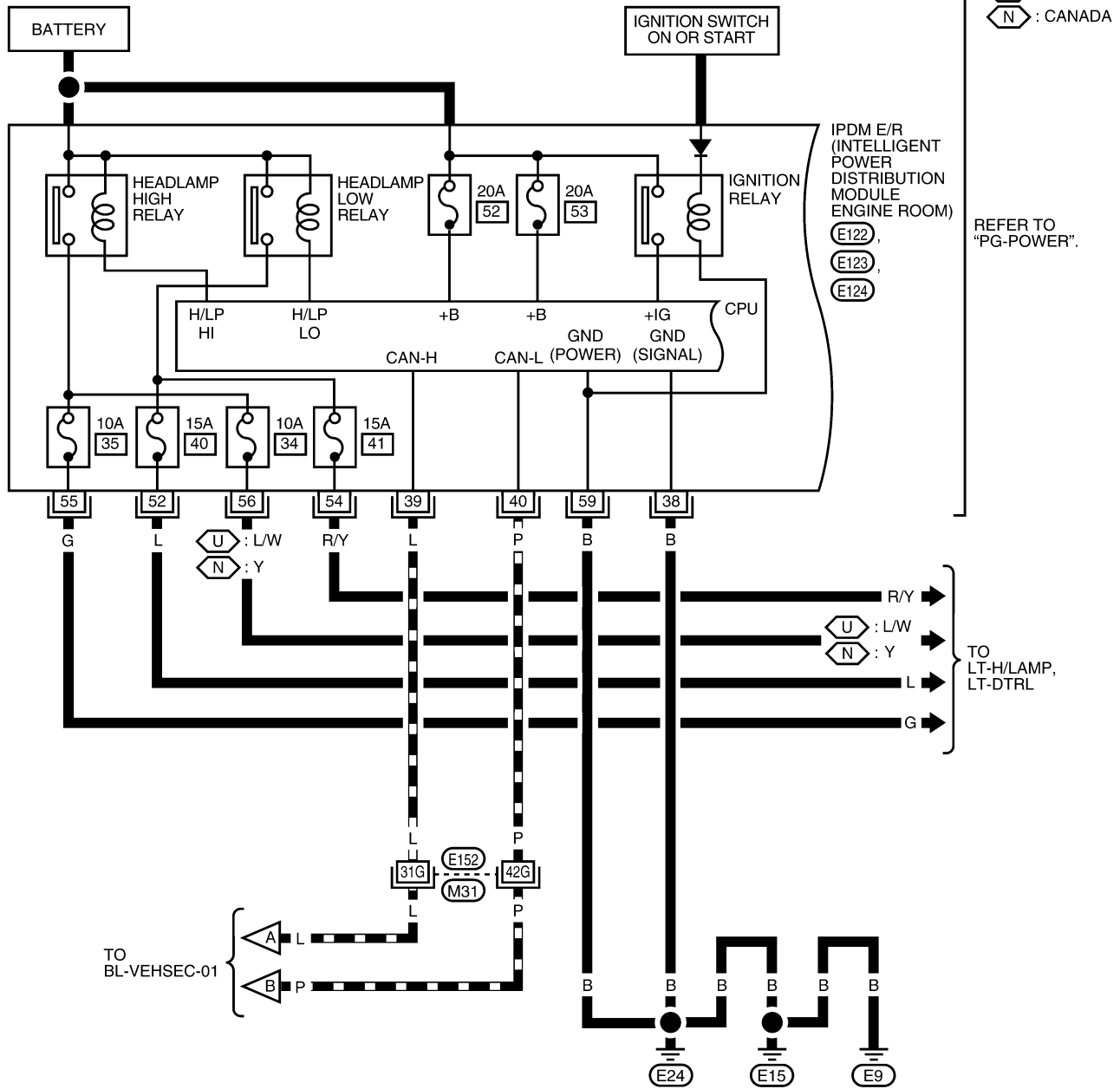

REFER TO THE FOLLOWING.
(M31) - SUPER MULTIPLE JUNCTION (SMJ)

WVWA0752E

VEHICLE SECURITY (THEFT WARNING) SYSTEM

BL-VEHSEC-05

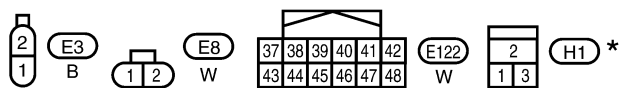
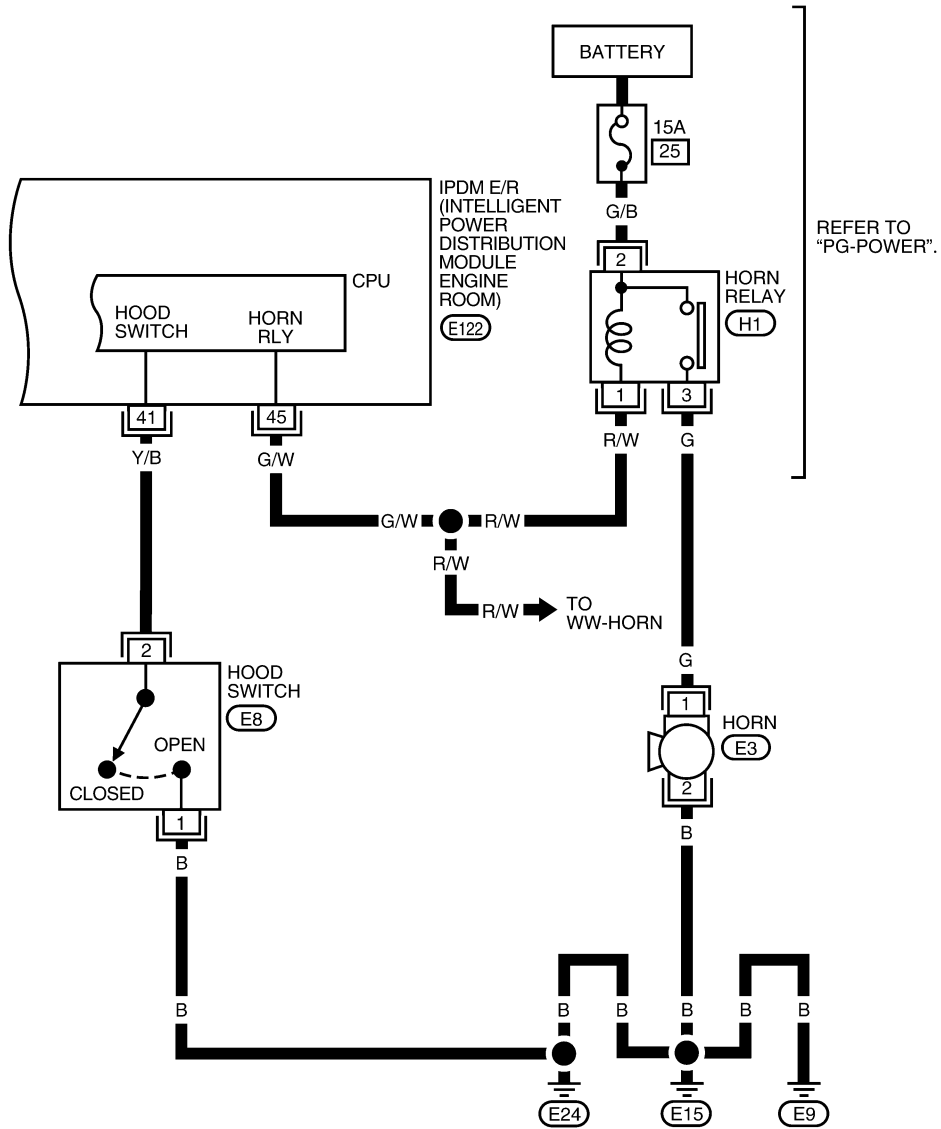

*: THIS CONNECTOR IS NOT SHOWN IN "HARNESS LAYOUT" OF PG SECTION.

WIWA1312E

VEHICLE SECURITY (THEFT WARNING) SYSTEM

Terminals and Reference Value for BCM

EIS00800

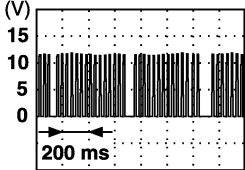
Terminal	Wire Color	Item	Condition	Voltage (V) (Approx.)
11	O	Ignition switch (ACC or ON)	Ignition switch (ACC or ON position)	Battery voltage
12	R/L	Front door switch RH	Door open (ON) → Door close (OFF)	0 → Battery voltage
13	GR	Rear door switch RH	Door open (ON) → Door close (OFF)	0 → Battery voltage
22	W/V	Bus	When ignition switch is ON or power window timer operates	 <p style="text-align: right; font-size: small;">PIIA2344E</p>
23	G/O	Combination meter (security indicator lamp)	Goes off → Illuminates (Every 2.4 seconds)	Battery voltage → 0
39	L	CAN-H	—	—
40	P	CAN-L	—	—
42	GR	Glass hatch ajar switch	Glass hatch open (ON) → Glass hatch close (OFF)	Battery voltage → 0
43	R/B	Back door latch (door ajar switch)	Door open (ON) → Door close (OFF)	0 → Battery voltage
47	SB	Front door switch LH	Door open (ON) → Door close (OFF)	0 → Battery voltage
48	R/Y	Rear door switch LH	Door open (ON) → Door close (OFF)	0 → Battery voltage
57	Y/R	Battery power supply	—	Battery voltage
67	B	Ground	—	0
70	W/B	Battery power supply	—	Battery voltage

A
B
C
D
E
F
G
H
J
K
L
M

BL

VEHICLE SECURITY (THEFT WARNING) SYSTEM

Terminals and Reference Value for IPDM E/R

EIS008QR

Terminal	Wire Color	Item	Condition		Voltage (V) (Approx.)
38	B	Ground	—		—
39	L	CAN-H	—		—
40	P	CAN-L	—		—
41	Y/B	Hood switch	Hood closed	OFF	0
			Hood open	ON	Battery voltage
45	G/W	Horn relay	When doors locks are operated using keyfob (OFF → ON) *1		Battery voltage → 0V
52	L	Headlamp low (LH)	Lighting switch 2ND position	OFF	0
				ON	Battery voltage
54	R/Y	Headlamp low (RH)	Lighting switch 2ND position	OFF	0
				ON	Battery voltage
55	G	Headlamp high (LH)	Lighting switch HIGH or PASS position	OFF	0
				ON	Battery voltage
56	L/W *2 Y *3	Headlamp high (RH)	Lighting switch HIGH or PASS position	OFF	0
				ON	Battery voltage
59	B	Ground	—		0

1*: when horn reminder is ON.

2*: L/W is for USA.

3*: Y is for Canada.

CONSULT-II Function (BCM)

EIS008QS

CONSULT-II can display each diagnostic item using the diagnostic test modes shown following.

BCM diagnostic test item	Diagnostic mode	Description
Inspection by part	WORK SUPPORT	Supports inspections and adjustments. Commands are transmitted to the BCM for setting the status suitable for required operation, input/output signals are received from the BCM and received date is displayed.
	DATA MONITOR	Displays BCM input/output data in real time.
	ACTIVE TEST	Operation of electrical loads can be checked by sending drive signal to them.
	SELF-DIAG RESULTS	Displays BCM self-diagnosis results.
	CAN DIAG SUPPORT MNTR	The result of transmit/receive diagnosis of CAN communication can be read.
	ECU PART NUMBER	BCM part number can be read.
	CONFIGURATION	Performs BCM configuration read/write functions.

CONSULT-II INSPECTION PROCEDURE

CAUTION:

If CONSULT-II is used with no connection of CONSULT-II CONVERTER, malfunctions might be detected in self-diagnosis depending on control unit which carries out CAN communication.

VEHICLE SECURITY (THEFT WARNING) SYSTEM

1. Turn ignition switch OFF.
2. Connect CONSULT-II and CONSULT-II CONVERTER to the data link connector.

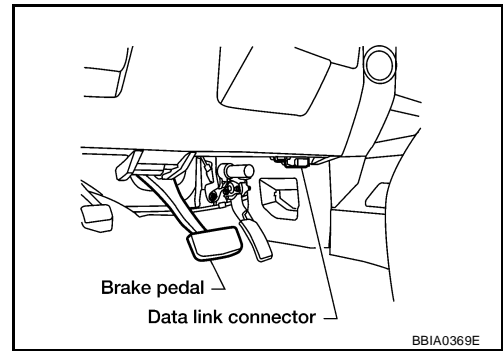

3. Turn ignition switch ON.
4. Touch "START (NISSAN BASED VHCL)".

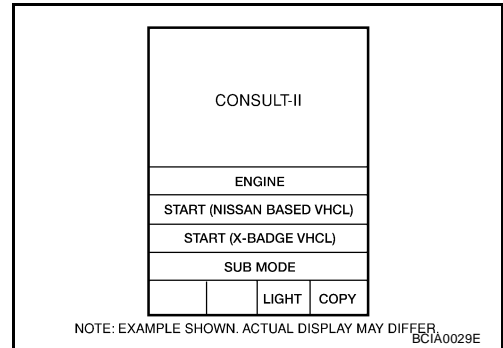

5. Touch "BCM".
If "BCM" is not indicated, refer to [GI-39, "CONSULT-II Data Link Connector \(DLC\) Circuit"](#).

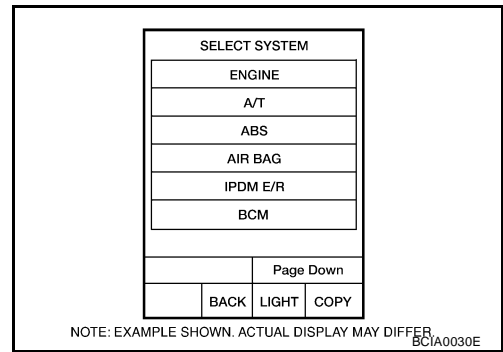

6. Touch "THEFT ALM" on the "SELECT TEST ITEM" screen.

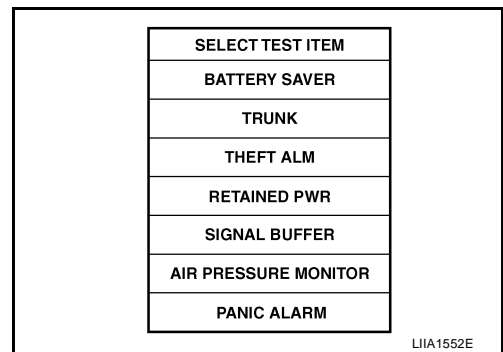

7. Select diagnosis mode.
"DATA MONITOR", "ACTIVE TEST" and "WORK SUPPORT" are available.

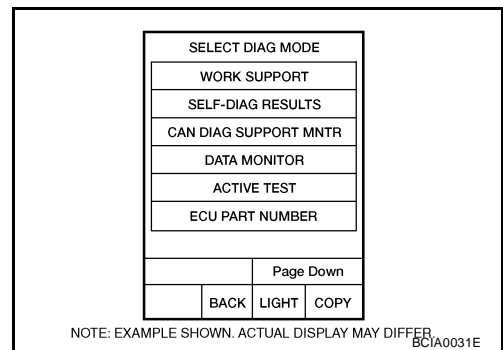

A
B
C
D
E
F
G
H
J
K
L
M

BL

VEHICLE SECURITY (THEFT WARNING) SYSTEM

CONSULT-II APPLICATION ITEM

Data Monitor

Monitored Item	Description
DOOR SW-AS	Indicates [ON/OFF] condition of front door switch RH.
DOOR SW-RR	Indicates [ON/OFF] condition of rear door switch RH.
DOOR SW-RL	Indicates [ON/OFF] condition of rear door switch LH.
DOOR SW-DR	Indicates [ON/OFF] condition of front door switch LH.
BACK DOOR SW	Indicates [ON/OFF] condition of back door latch.
TRNK OPN MNTR	Indicates [ON/OFF] condition of glass hatch ajar switch.
ACC ON SW	Indicates [ON/OFF] condition of ignition switch in ACC position.
IGN ON SW	Indicates [ON/OFF] condition of ignition switch in ON position.
KEYLESS UNLOCK	Indicates [ON/OFF] condition of unlock signal from keyfob.
KEYLESS LOCK	Indicates [ON/OFF] condition of lock signal from keyfob.
KEY CYL LK-SW	Indicates [ON/OFF] condition of lock signal from door key cylinder switch.
KEY CYL UN-SW	Indicates [ON/OFF] condition of unlock signal from door key cylinder switch.
KEYLESS PBD	Indicates [ON/OFF] condition of unlock signal from door key cylinder switch.
CDL UNLOCK SW	Indicates [ON/OFF] condition of unlock signal from lock/unlock switch.
CDL LOCK SW	Indicates [ON/OFF] condition of lock signal from lock/unlock switch.
HOOD SW	Indicates [ON/OFF] condition of hood switch.

Active Test

Test Item	Description
THEFT IND	This test is able to check security indicator lamp operation. The lamp will be turned on when "ON" on CONSULT-II screen is touched.
HEADLAMP (HI)	This test is able to check vehicle security lamp operation. The high beam headlamps will be activated for 0.5 seconds after "ON" on CONSULT-II screen is touched.
VEHICLE SECURITY HORN	This test is able to check vehicle security horn operation. The horns will be activated for 0.5 seconds after "ON" on CONSULT-II screen is touched.

Work Support

Test Item	Description
SECURITY ALARM SET	This mode can confirm and change security alarm ON-OFF setting.
THEFT ALM TRG	The switch which triggered vehicle security alarm is recorded. This mode is able to confirm and erase the record of vehicle security alarm. The trigger data can be erased by touching "CLEAR" on CONSULT-II screen.

VEHICLE SECURITY (THEFT WARNING) SYSTEM

Trouble Diagnosis WORK FLOW

EIS0080T

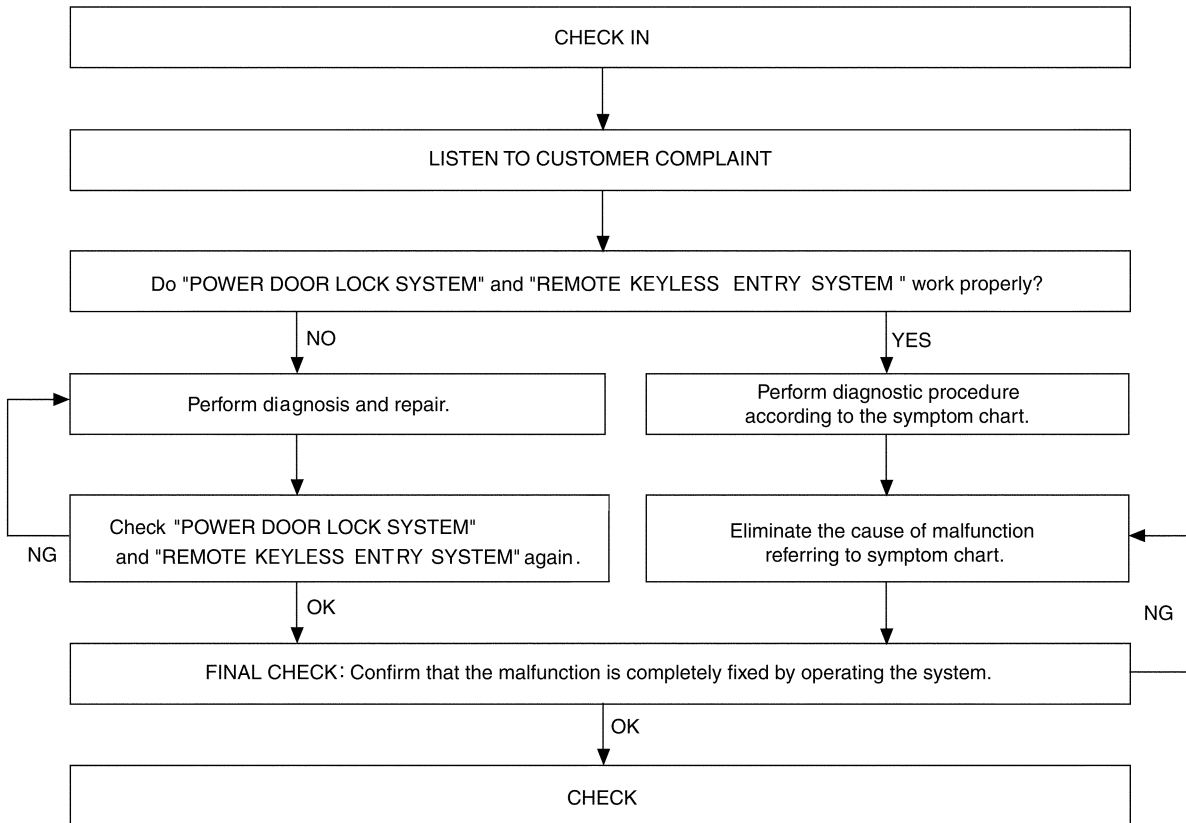

WIA0599E

- "POWER DOOR LOCK SYSTEM" Diagnosis refer to [BL-16, "POWER DOOR LOCK SYSTEM"](#) .
- "REMOTE KEYLESS ENTRY SYSTEM" Diagnosis refer to [BL-44, "REMOTE KEYLESS ENTRY SYSTEM"](#) .

VEHICLE SECURITY (THEFT WARNING) SYSTEM

EIS008QU

Preliminary Check

The system operation is canceled by turning ignition switch to ACC at any step between START and ARMED in the following flow chart.

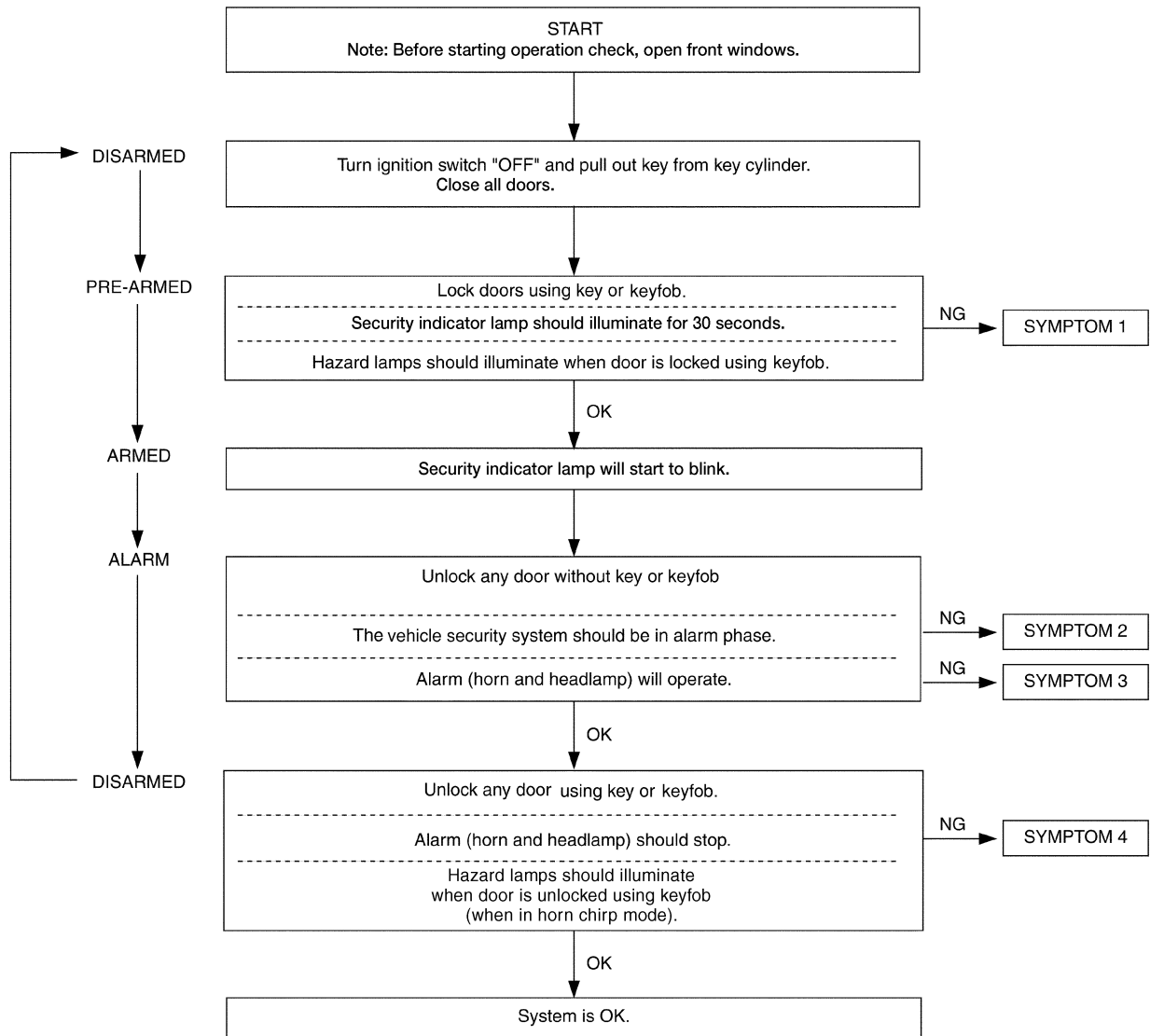

WIIA0627E

After performing preliminary check, go to symptom chart.

VEHICLE SECURITY (THEFT WARNING) SYSTEM

Symptom Chart

EIS0080V

	SYMPTOM	PROCEDURE	Diagnostic procedure
1	Vehicle security system cannot be set by	Door switch	Refer to BL-92, "Door Switch Check" .
		Lock/unlock switch	Refer to BL-98, "Door Lock/Unlock Switch Check" .
		Door outside key	Refer to BL-96, "Front Door Lock Assembly LH (Key Cylinder Switch) Check" .
		BCM	If the above systems are "OK", replace BCM. Refer to BCS-20, "Removal and Installation of BCM" .
2	Security indicator does not turn "ON".	Combination meter	Refer to BL-95, "Combination Meter (Security Indicator Lamp) Check" .
		BCM	If the above systems are "OK", replace BCM. Refer to BCS-20, "Removal and Installation of BCM" .
3	*1 Vehicle security system does not alarm when	Any door, hood or glass hatch is opened.	Refer to BL-92, "Door Switch Check" . Refer to BL-94, "Hood Switch Check" . If the above systems are "OK", replace BCM. Refer to BCS-20, "Removal and Installation of BCM" .
4	Vehicle security alarm does not activate.	Horn alarm	Refer to BL-98, "Vehicle Security Horn Alarm Check" . If the above systems are "OK", check horn system. Refer to WW-58, "HORN" .
		Headlamp alarm	Refer to BL-98, "Vehicle Security Headlamp Alarm Check" . If the above systems are "OK", replace BCM. Refer to BCS-20, "Removal and Installation of BCM" .
5	Vehicle security system cannot be canceled by	Door outside key	Refer to BL-96, "Front Door Lock Assembly LH (Key Cylinder Switch) Check" . If the above systems are "OK", check main power window and door lock/unlock switch.
		Keyfob	Check remote keyless entry function. Refer to BL-65, "Keyfob Battery and Function Check" . If the above systems are "OK", replace BCM. Refer to BCS-20, "Removal and Installation of BCM" .

*1: Make sure the system is in the armed phase.

A
B
C
D
E
F
G
H
BL
J
K
L
M

VEHICLE SECURITY (THEFT WARNING) SYSTEM

EIS008QW

Door Switch Check

1. CHECK DOOR SWITCHES INPUT SIGNAL

 With CONSULT-II

Check door switches ("DOOR SW-DR", "DOOR SW-AS", "DOOR SW-RL", "DOOR SW-RR", "BACK DOOR SW", "TRNK OPN MNTR") in DATA MONITOR mode with CONSULT-II. Refer to [BL-27, "DATA MONITOR"](#).

- When doors are open:

DOOR SW-DR : ON
DOOR SW-AS : ON
DOOR SW-RL : ON
DOOR SW-RR : ON
BACK DOOR SW : ON
TRNK OPN MNTR : ON

- When doors are closed:

DOOR SW-DR : OFF
DOOR SW-AS : OFF
DOOR SW-RL : OFF
DOOR SW-RR : OFF
BACK DOOR SW : OFF
TRNK OPN MNTR : OFF

DATA MONITOR	
MONITOR	
DOOR SW - DR	OFF
DOOR SW - AS	OFF
DOOR SW - RR	OFF
DOOR SW - RL	OFF
BACK DOOR SW	OFF
TRNK OPN MNTR	OFF

WIIA0466E

 Without CONSULT-II

Check voltage between BCM connector M18 or M19 terminals 12, 13, 42, 43, 47, 48 and ground.

Connector	Item	Terminals		Condition	Voltage (V) (Approx.)
		(+)	(-)		
M19	Glass hatch ajar switch	42	Ground	Open ↓ Closed	0 ↓ Battery voltage
	back door latch (door ajar switch)	43			
	Front door switch LH	47			
	Rear door switch LH	48			
M18	Front door switch RH	12	Ground	Open ↓ Closed	0 ↓ Battery voltage
	Rear door switch RH	13			

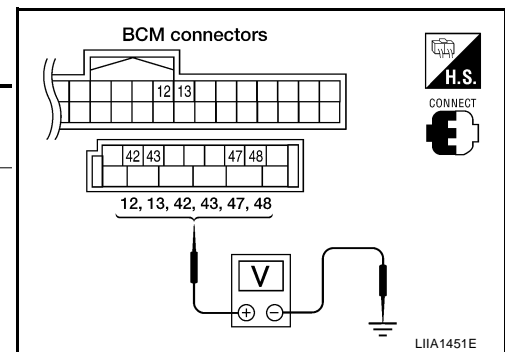

OK or NG

- OK >> Door switch circuit is OK.
- NG >> GO TO 2.

VEHICLE SECURITY (THEFT WARNING) SYSTEM

2. CHECK DOOR SWITCH CIRCUIT

1. Turn ignition switch OFF.
2. Disconnect door switch and BCM.
3. Check continuity between door switch connector (B) B8 (front LH), B108 (front RH), B18 (rear LH), B116 (rear RH) terminal 2 or back door latch connector (C) D503 terminal 7 and BCM connectors (A) M18, M19 terminals 12, 13, 43, 47 and 48.

2 - 12 : Continuity should exist.

2 - 13 : Continuity should exist.

2 - 47 : Continuity should exist.

2 - 48 : Continuity should exist.

7 - 43 : Continuity should exist.

4. Check continuity between door switch connector (B) B8 (front LH), B108 (front RH), B18 (rear LH), B116 (rear RH) terminal 2 or back door latch connector (C) D503 terminal 7 and ground.

2 - Ground : Continuity should not exist.

7 - Ground : Continuity should not exist.

OK or NG

OK >> GO TO 3.

NG >> Repair or replace harness.

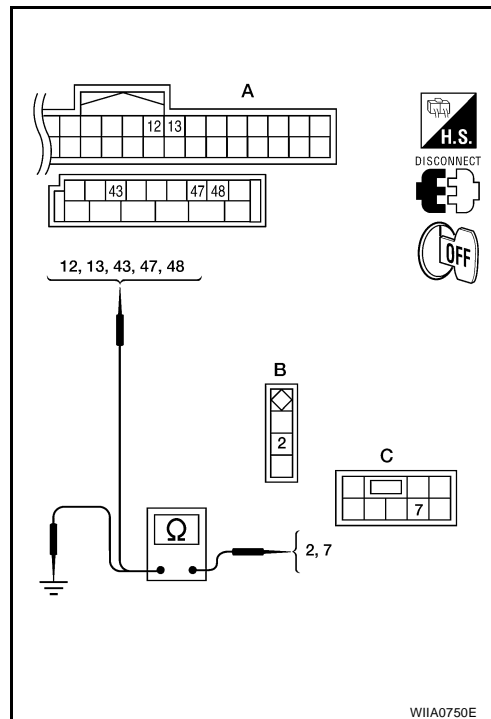

3. CHECK DOOR SWITCHES

FRONT AND REAR DOORS

Check continuity between front or rear door switch terminal 2 and exposed metal of switch while pressing and releasing switch.

Door switch is released : Continuity should exist.

Door switch is pushed : Continuity should not exist.

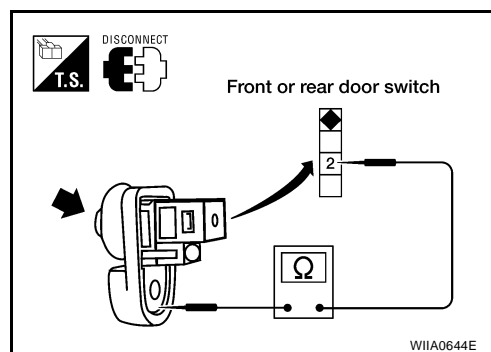

BACK DOOR

Check continuity between back door latch connector (A) D503 terminals 7 and 8 while pressing (closing back door) and releasing (opening back door) switch.

When back door is open : Continuity should exist.

When back door is closed : Continuity should not exist.

OK or NG

OK >> (Front and rear doors) Switch circuit is OK.

OK >> (Back door) GO TO 4.

NG >> Replace door switch.

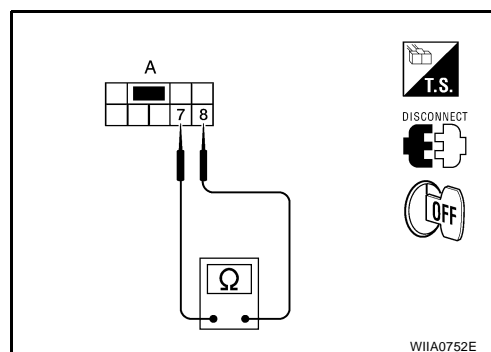

VEHICLE SECURITY (THEFT WARNING) SYSTEM

4. CHECK BACK DOOR SWITCH GROUND

Check continuity between back door latch connector terminal 8 and ground.

8 - Ground : Continuity should exist.

OK or NG

- OK >> Back door switch circuit is OK.
- NG >> Repair or replace harness.

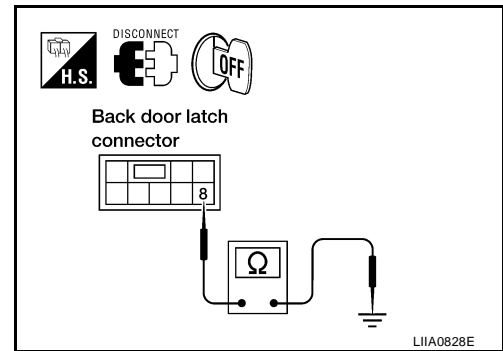

Hood Switch Check

1. CHECK HOOD SWITCH

Check hood switch and hood fitting condition.

OK or NG

- OK >> GO TO 2.
- NG >> Adjust installation of hood switch.

2. CHECK HOOD SWITCH INPUT SIGNAL

With CONSULT-II
Check "HOOD SW" in "DATA MONITOR" mode with CONSULT-II.

When hood is open : HOOD SW ON
When hood is closed : HOOD SW OFF

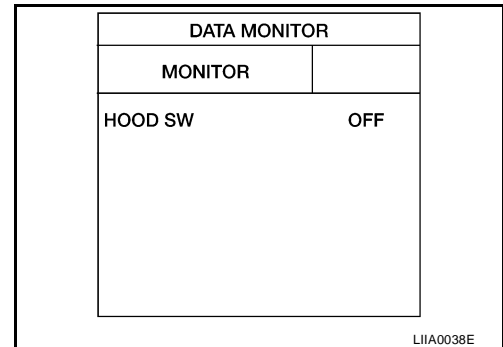

Without CONSULT-II
Check voltage between IPDM E/R harness connector E122 terminal 41 and ground.

OK or NG

- OK >> Hood switch is OK.
- NG >> GO TO 3.

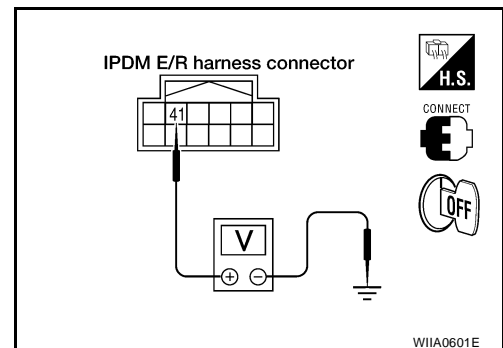

VEHICLE SECURITY (THEFT WARNING) SYSTEM

3. CHECK HOOD SWITCH

1. Turn ignition switch OFF.
2. Disconnect hood switch connector.
3. Check continuity between hood switch terminals 1 and 2.

Terminals	Condition	Continuity
1- 2	Pressed	No
	Released	Yes

OK or NG

OK >> Check the following:

- Hood switch ground circuit.
- Harness for open or short between hood switch and IPDM E/R

NG >> Replace hood switch.

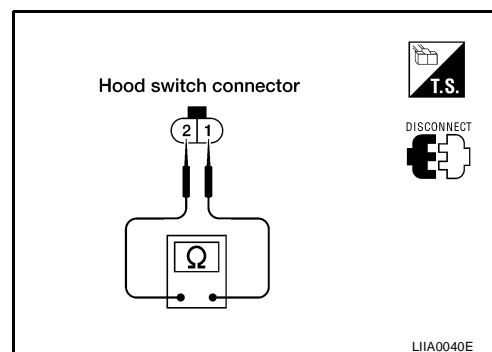

Combination Meter (Security Indicator Lamp) Check

E/S008QY

1. SECURITY INDICATOR LAMP ACTIVE TEST

Ⓜ With CONSULT-II

Check "THEFT IND" in "ACTIVE TEST" mode with CONSULT-II.

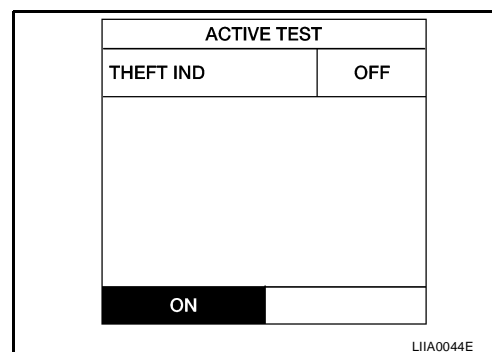

ⓧ Without CONSULT-II

1. Disconnect BCM.
2. Check voltage between BCM harness connector M18 terminal 23 and ground.

Connector	Terminals		Condition	Voltage (V) (Approx.)
	(+)	(-)		
M18	23	Ground	ON	0
			OFF	Battery voltage

OK or NG

OK >> Security indicator lamp is OK.

NG >> GO TO 2.

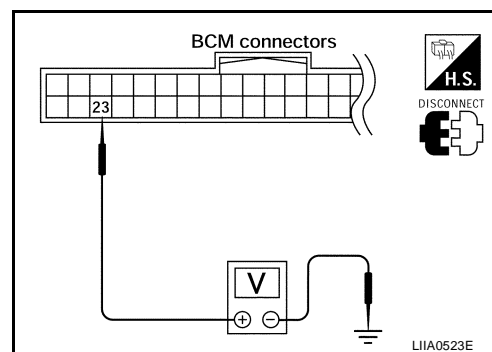

2. SECURITY INDICATOR LAMP CHECK

Check security indicator lamp condition.
Refer to [DI-5, "COMBINATION METERS"](#) .

OK or NG

OK >> GO TO 3.

NG >> Replace combination meter (security indicator lamp). Refer to [DI-8, "Combination Meter"](#) .

VEHICLE SECURITY (THEFT WARNING) SYSTEM

3. CHECK HARNESS CONTINUITY

1. Turn ignition switch OFF.
2. Disconnect BCM and combination meter (security indicator lamp).
3. Check continuity between BCM connector (A) M18 terminal 23 and combination meter (security indicator lamp) harness connector (B) M24 terminal 28.

23 - 28 : Continuity should exist.

4. Check continuity between BCM connector (A) M18 terminal 23 and ground.

23 - ground : Continuity should not exist.

OK or NG

OK >> Check the following:

- 10A fuse [No. 19, located in fuse block (J/B)]
- Harness for open or short between combination meter (security indicator lamp) and fuse

NG >> Repair or replace harness.

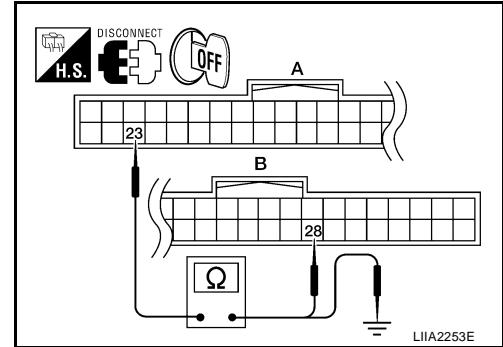

Front Door Lock Assembly LH (Key Cylinder Switch) Check

EIS0080Z

1. CHECK FRONT DOOR LOCK ASSEMBLY LH (KEY CYLINDER SWITCH)

Ⓛ With CONSULT-II

Check front door lock assembly LH (key cylinder switch) ("KEY CYL LK-SW") and ("KEY CYL UN-SW") in DATA MONITOR mode in CONSULT-II. Refer to [BL-27, "DATA MONITOR"](#).

- When key inserted in front key cylinder is turned to LOCK:

KEY CYL LK-SW : ON

- When key inserted in front key cylinder is turned to UNLOCK:

KEY CYL UN-SW : ON

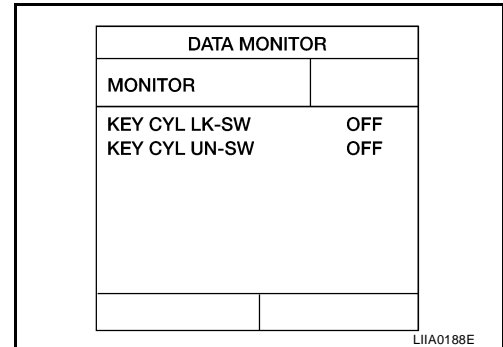

Ⓧ Without CONSULT-II

Check voltage between main power window and door lock/unlock switch connector D7 terminals 4, 6 and ground.

Connector	Terminals		Condition	Voltage (V) (Approx.)
	(+)	(-)		
D7	4	Ground	Neutral/Unlock	5
			Lock	0
	6		Neutral/Lock	5
			Unlock	0

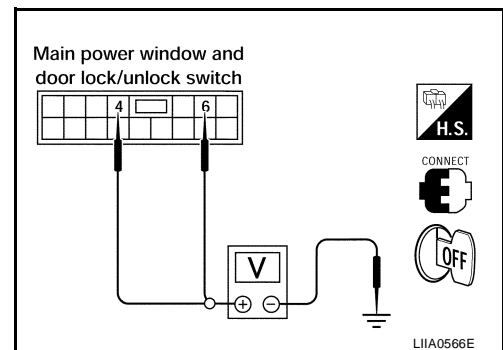

OK or NG

OK >> Front door lock assembly LH (key cylinder switch) signal is OK.

NG >> GO TO 2.

VEHICLE SECURITY (THEFT WARNING) SYSTEM

2. CHECK DOOR KEY CYLINDER SWITCH LH GROUND HARNESS

Check continuity between front door lock assembly LH (key cylinder switch) connector (A) D14 terminal 5 and body ground.

Connector	Terminals	Continuity
D14	5 – Ground	Yes

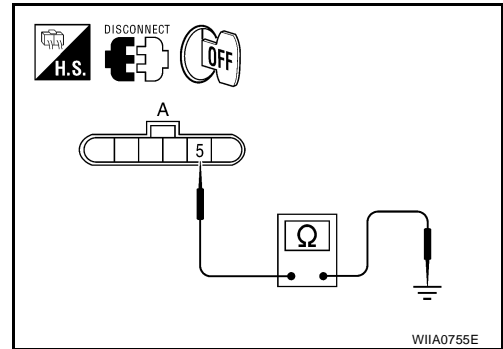

OK or NG

- OK >> GO TO 3.
- NG >> Repair or replace harness.

3. CHECK DOOR KEY CYLINDER SWITCH LH

Check continuity between front door lock assembly LH (key cylinder switch) terminals.

Terminals	Condition	Continuity
1 – 5	Key is turned to UNLOCK or neutral.	No
	Key is turned to LOCK.	Yes
5 – 6	Key is turned to LOCK or neutral.	No
	Key is turned to UNLOCK.	Yes

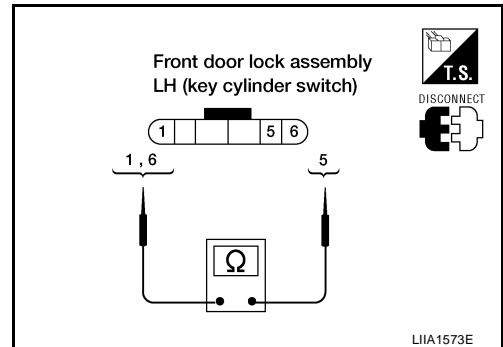

OK or NG

- OK >> GO TO 4.
- NG >> Replace front door lock assembly LH (key cylinder switch). Refer to [BL-131, "Removal and Installation"](#).

4. CHECK DOOR KEY CYLINDER HARNESS

Check continuity between main power window and door lock/unlock switch connector (A) D7 terminals 4, 6 and front door lock assembly LH (key cylinder switch) connector (B) D14 terminals 1, 6 and body ground.

Connector	Terminals	Connector	Terminals	Continuity
A: Main power window and door lock/unlock switch	4	B: Front door lock assembly LH (key cylinder switch)	1	Yes
	6		6	Yes
	4, 6	Ground	No	

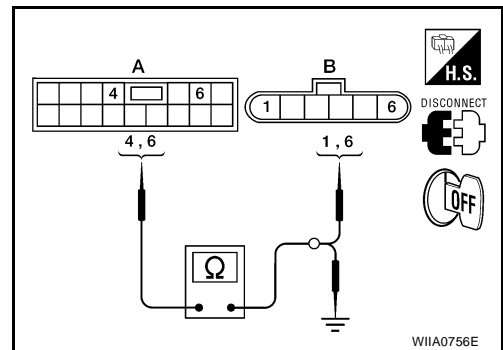

OK or NG

- OK >> Replace main power window and door lock/unlock switch.
- NG >> Repair or replace harness.

VEHICLE SECURITY (THEFT WARNING) SYSTEM

Vehicle Security Horn Alarm Check

EIS008R0

1. CHECK HORN OPERATION

Check if horn sounds with horn switch.

Does horn operate?

- YES >> Check harness for open or short between IPDM E/R and horn relay.
- NO >> Check horn circuit. Refer to [WW-58, "HORN"](#) .

Vehicle Security Headlamp Alarm Check

EIS008R1

1. CHECK VEHICLE SECURITY HEADLAMP ALARM OPERATION

Check if headlamps operate with lighting switch.

Do headlamps come on when turning switch ON?

- YES >> Headlamp alarm is OK.
- NO >> Check headlamp system. Refer to [LT-6, "HEADLAMP \(FOR USA\)"](#) or [LT-33, "HEADLAMP \(FOR CANADA\) - DAYTIME LIGHT SYSTEM -"](#) .

Door Lock/Unlock Switch Check

EIS008R2

1. CHECK DOOR LOCK/UNLOCK SWITCH INPUT SIGNAL

Check if power door lock operates with door lock/unlock switch.

Do doors lock/unlock when using each door lock/unlock switch?

- YES >> Door lock/unlock switch is OK.
- NO >> Refer to [BL-34, "Door Lock/Unlock Switch Check"](#) .

AUTOMATIC BACK DOOR SYSTEM

AUTOMATIC BACK DOOR SYSTEM

PFP:82580

Component Parts and Harness Connector Location

EIS008R3

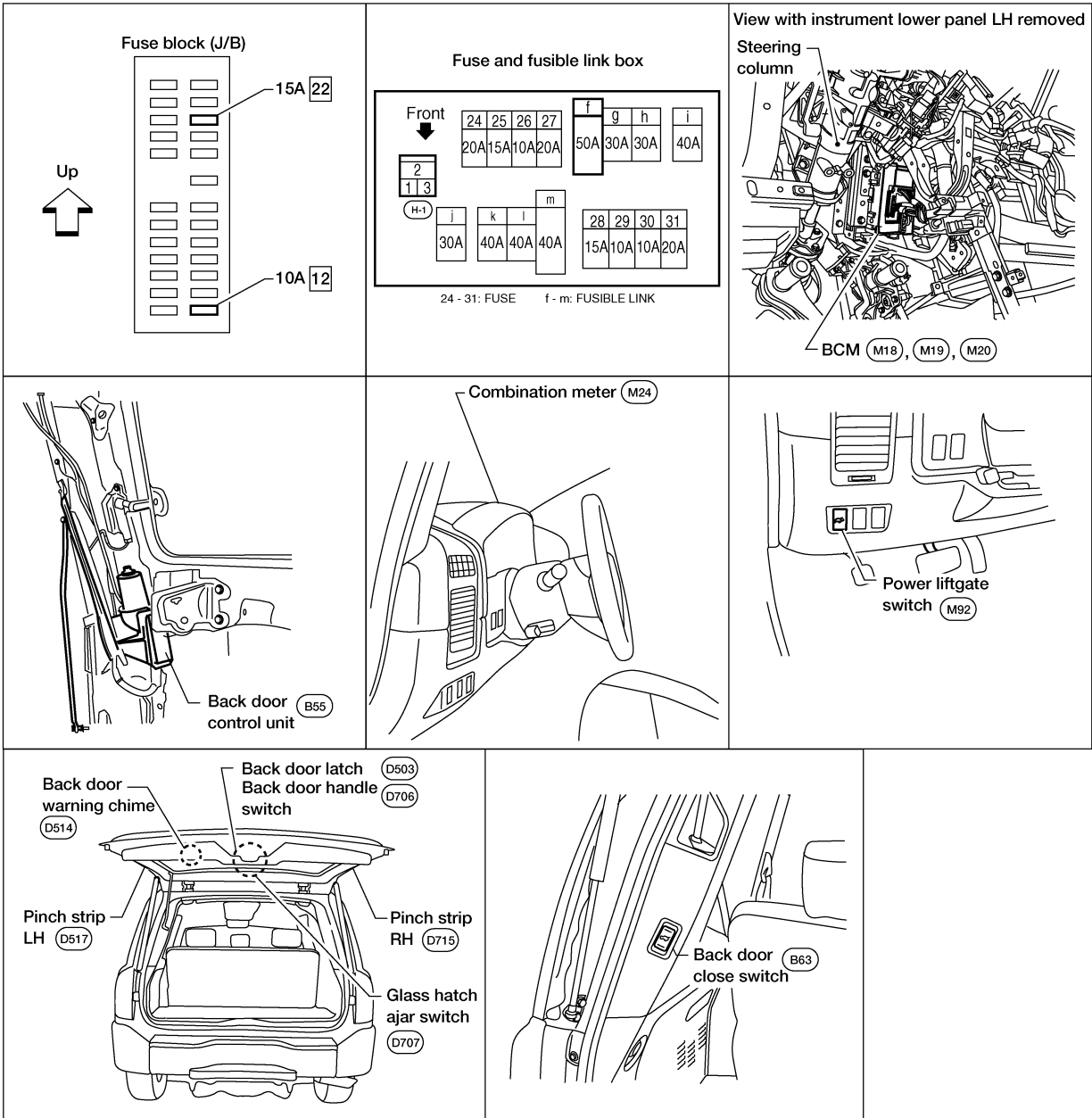

A
B
C
D
E
F
G
H
BL
J
K
L
M

LIA2059E

AUTOMATIC BACK DOOR SYSTEM

EIS008R4

System Description

NOTE:

The automatic back door system must be initialized by fully closing the back door anytime the battery or the back door control unit has been disconnected.

The automatic back door system consists of a one piece unit that combines the back door control unit along with the back door motor, back door clutch and the back door encoder. The back door latch contains a lock function that can control the two functions of automatic back door latch closure and electrical opener with a single motor when you close the back door to the halfway-state.

- Back door auto closure
When the back door is closed to the halfway state (half-latch) position, the motor automatically drives to rotate the latch lever and pull it in from half latched to full latched.
- Power back door
With the back door closed, press the power liftgate switch or press the remote keyless entry button, or pull the back door handle with the back door unlocked, the back door latch motor opens the locking plate and releases the latch. The back door motor then raises the door to the full open position.
With the back door fully open, press the power liftgate switch, remote keyless entry button or the back door close switch, the back door motor closes the door to the half-latch state. The back door latch motor then drives the latch to the full close position.
At the onset of each power open or power close application, the hazard lamps will flash 3 times and the warning chime will sound 3 times lasting a total of 2 seconds.

OPERATION DESCRIPTION

Power Liftgate Switch Operation (Fully Closed → Fully Open Operation)

- When the power liftgate switch is pressed, back door control unit terminal 23 receives the signal.
- The back door control unit checks the A/T selector lever (P position) through terminal 18, vehicle speed through terminal 21, ignition status through terminal 7, glass hatch is closed through terminal 17 and battery voltage is present through terminal 3.
- When the back door control unit receives the signal, if the auto back door operating enable conditions are met, it sends a 5 volt signal through terminal 6 and grounds terminal 9 to sound the warning chime, sends a signal to the BCM through terminal 4 to flash the hazard lamps and unlocks the back door latch through terminal 12.
- The back door control unit supplies power to the magnetic clutch and the back door motor and moves the back door in the open direction. (At this time, it also executes speed control, input reverse, and anti-pinch detection control.)
- When the back door is opened to the full-open position, the full-open position is detected by the encoder, and the back door control unit switches the back door motor OFF and the magnetic clutch is pulsed and then turned OFF.
- The back door is held in the fully open position by the gas stays.

Remote Keyless Entry Operation (Fully Closed → Fully Open Operation)

- When the remote keyless entry button is pressed for at least 0.5 seconds, back door control unit terminal 21 receives the signal.
- The back door control unit checks the A/T selector lever (P position) through terminal 18, vehicle speed through terminal 21, ignition status through terminal 7, glass hatch is closed through terminal 17 and battery voltage is present through terminal 3.
- When the back door control unit receives the signal, if the auto back door operating enable conditions are met, it sends a 5 volt signal through terminal 6 and grounds terminal 9 to sound the warning chime, sends a signal to the BCM through terminal 4 to flash the hazard lamps and unlocks the back door latch through terminal 12.
- The back door control unit supplies power to the magnetic clutch and the back door motor and moves the back door in the open direction. (At this time, it also executes speed control, input reverse, and anti-pinch detection control.)
- When the back door is opened to the full-open position, the full-open position is detected by the encoder, and the back door control unit switches the back door motor OFF and the magnetic clutch is pulsed and then turned OFF.
- The back door is held in the fully open position by the gas stays.

AUTOMATIC BACK DOOR SYSTEM

Back Door Handle Switch Operation (Fully Closed → Fully Open Operation)

- When the back door handle is pulled, back door control unit terminal 26 receives the signal. A
- The back door control unit checks that the back door is unlocked and checks the A/T selector lever (P position) through terminal 18, vehicle speed through terminal 21, ignition status through terminal 7, glass hatch is closed, battery voltage and back door close switch position through terminal 13. B
- When the back door control unit receives the signal, if all auto back door operating enable conditions are met, it sends a 5 volt signal through terminal 6 and grounds terminal 9 to sound the warning chime, sends a signal to the BCM through terminal 4 to flash the hazard lamps and unlocks the back door latch through terminal 12. C
- The back door control unit supplies power to the magnetic clutch and the back door motor and moves the back door in the open direction. (At this time, it also executes speed control, input reverse, and anti-pinch detection control.) D
- When the back door is opened to the full-open position, the full-open position is detected by the encoder, and the back door control unit switches the back door motor OFF and the magnetic clutch is pulsed and then turned OFF. E
- The back door is held in the fully open position by the gas stays.

Power Liftgate Switch Operation (Fully Open → Fully Closed Operation)

- When the power liftgate switch is pressed, the back door control unit terminal 23 receives the signal. F
- The back door control unit checks door position through the rotary encoder. G
- When the back door control unit receives the signal, if the auto back door operating enable conditions are met, it sends a signal through terminal 6 and grounds terminal 9 to sound the warning chime and sends a signal to the BCM through terminal 4 to flash the hazard lamps. H
- The back door control unit supplies power to the magnetic clutch and the back door motor and move the back door in the close direction. (At this time, it also executes speed control, input reverse, and anti-pinch detection control.)
- When the back door reaches the half-latch state, the half-latch switch detects this and the signal is sent to the back door control unit terminal 22. BL
- When the back door control unit receives the half latch switch signal, it switches OFF the back door motor and the magnetic clutch and operates the cinch latch motor. J
- When the back door latch operates and full close is detected through terminal 14 of the back door control unit, the cinch latch motor reverses to the neutral position and the back door auto closure operation ends and the door is fully closed. K

Remote Keyless Entry Operation (Fully Open → Fully Closed Operation)

- When the remote keyless entry switch is pressed for at least 0.5 seconds, the back door control unit terminal 21 receives the signal. L
- The back door control unit checks door position through the rotary encoder.
- When the back door control unit receives the signal, if the auto back door operating enable conditions are met, it sends a signal through terminal 6 and grounds terminal 9 to sound the warning chime and sends a signal to the BCM through terminal 4 to flash the hazard lamps. M
- The back door control unit supplies power to the magnetic clutch and the back door motor and move the back door in the close direction. (At this time, it also executes speed control, input reverse, and anti-pinch detection control.)
- When the back door reaches the half-latch state, the half-latch switch detects this and the signal is sent to the back door control unit terminal 22.
- When the back door control unit receives the half latch switch signal, it switches OFF the back door motor and the magnetic clutch and operates the cinch latch motor.
- When the back door latch operates and full close is detected through terminal 14 of the back door control unit, the cinch latch motor reverses to the neutral position and the back door auto closure operation ends and the door is fully closed.

AUTOMATIC BACK DOOR SYSTEM

Back Door Close Switch Operation (Fully Open → Fully Closed Operation)

- When the back door close switch is pressed, the back door control unit terminal 8 receives the signal.
- The back door control unit checks back door close switch terminal 13 status and door position (must be fully opened), through rotary encoder and battery voltage.
- When the back door control unit receives the signal, if the auto back door operating enable conditions are met, it sends a signal through terminal 6 and grounds terminal 9 to sound the warning chime and sends a signal to the BCM through terminal 4 to flash the hazard lamps.
- The back door control unit supplies power to the magnetic clutch and the back door motor and move the back door in the close direction. (At this time, it also executes speed control, input reverse, and anti-pinch detection control.)
- When the back door reaches the half-latch state, the half-latch switch detects this and the signal is sent to the back door control unit terminal 22.
- When the back door control unit receives the half latch switch signal, it switches OFF the back door motor and the magnetic clutch and operates the cinch latch motor.
- When the back door latch operates and full close is detected through terminal 14 of the back door control unit, the cinch latch motor reverses to the neutral position and the back door auto closure operation ends and the door is fully closed.

Reversal

- If the power liftgate switch, remote keyless entry switch or the back door close switch is pressed during back door power open and close operation, the back door will reverse direction.
- If the outside handle switch is pulled during power open or power close, the power back door will automatically stop and go to manual mode.

Anti-Pinch Function

- During auto open or close operation, if an object is detected in the door's path, the back door operates in the reverse direction until fully closed or open to prevent pinching.
- During auto close operation, if an object is detected by the pinch strips in the door's path, the back door operates in the open direction until it is fully open.
- During auto cinch latch operation, if an object is detected by the pinch strips in the door's path, the back door operates depending on the back door close switch position. If the back door close switch is in the OFF position, the back door operates in the open direction until it is fully open. If the back door close switch is in the ON position, the back door will reverse only until the latch is fully released.
- If the pinch strips are present but are not functioning properly (permanently sensing a pinch), the automatic back door system will operate in the open direction only.
- If the pinch strips are not connected to the automatic back door system, it will not operate.

Gas Stay Check

- During each power open operation, the back door control unit monitors motor current draw to determine if the gas stays are functioning properly.
- If a failure of the gas stays is detected, the back door control unit will close the back door while sounding the warning chime.

Warning Functions

- The warning chime is sounded according to the back door operating state, operations, and conditions.

AUTOMATIC BACK DOOR SYSTEM

Auto Back Door Operation Enable Conditions

Operation	Power liftgate switch		Remote keyless entry		Back door handle switch		Back door close switch
Operating direction	Fully closed → open	Fully open → closed	Fully closed → open	Fully open → closed	Fully closed → open	Fully open → closed	Fully open → closed
Close switch	CANCEL or NEUTRAL				NEUTRAL		NEUTRAL
Vehicle stop condition	A/T selector lever in P or N range and vehicle speed less than 2 km/h or ignition switch in OFF position	—	A/T selector lever in P or N range and vehicle speed less than 2 km/h or ignition switch in OFF position	—	A/T selector lever in P or N range and vehicle speed less than 2 km/h or ignition switch in OFF position	—	—
Battery voltage	Approx. 11V or more						
Back door lock status	—	—	—	—	Unlocked	—	—
Glass hatch	Closed						

Control When Operating Enable Conditions Not Met During Power Open/Close

Items	Operation condition	Not met case	Control
A/T selector lever P position	P or N position with ignition ON or any position with ignition OFF	Other	Continue power open or close, but sounds warning chime.
Back door close switch	NEUTRAL	CANCEL	Cancels power open/close operation or door will release to manual mode.
Voltage drop	11V or more	11 > V > 9	
		9 > V > reset voltage	
		reset voltage > V	No power function available
Handle switch	Normal (GND)	Error (OPEN)	No operation. Cancel power open/close release to manual.
Glass hatch	Closed	OFF	Cancels power door open operation, door will release to manual mode.

Control When Operating Enable Conditions No Longer Met

Description	Operation	Control
Back door close switch turned to CANCEL	Warning chime active → Shift to manual mode after full open or close operation is complete (Recovery to power mode when main switch turned OFF or door fully closed)	→ Shift to manual mode
A/T selector lever P or N position with ignition switch ON	Warning chime active and one-way operation continuous (Warning chime inactive and door fully open or fully closed or operating conditions recovered)	Full open: power close operation allowed Full close: operating conditions not met → no power open function.
Voltage drop 11 - 9V	One-way operation continued (equivalent to the case of starting voltage ← 11V for handle operation with warning chime active)	Not allowed
Voltage drop less than 9V (Microcomputer reset voltage - clutch hold voltage)	<ul style="list-style-type: none"> ● Motor stopped ● Clutch may slip ● Control not possible because microcomputer being reset 	Control not possible because microcomputer being reset

AUTOMATIC BACK DOOR SYSTEM

Warning Chime Active Conditions

The warning chime uses two types of audio warnings, a friendly chime and a warning chime. The friendly chime consists of dings lasting 0.66 seconds each immediately followed by the next ding. The warning chime consists of beeps lasting 0.33 seconds with a pause of 0.33 seconds between each beep.

Operation status	Operation or conditions	Warning chime pattern
When auto operation starts	Power liftgate switch operation	Friendly chime 2 seconds, 3 dings
	Remote keyless entry operation	
	Back door handle switch operation	
	Back door close switch operation	
When reverse operation starts	When reverse request is detected from power liftgate switch, remote keyless entry or back door close switch	Friendly chime 1.3 seconds, 2 dings
	When obstacle is detected	Warning chime 2 seconds, 3 beeps
Operating at low voltage	While opening or closing	Warning chime 2 seconds, 3 beeps
A/T selector lever not in P position	Back door close operation	Friendly chime Continuously dings
	Back door open operation	Warning chime Continuously beeps (until close operation is started)

Reverse Conditions

Type	Overload reverse
Operation covered	Both directions
Detection method	Operation speed and motor current change direction
	Pinch strips during back door close operation
Non-reversed area	<ul style="list-style-type: none"> ● For about 0.5 seconds immediately after drive motor operation starts ● Between full open and approx. 7° from full open ● Closure operation area (half switch - close switch)
Number of times reverse allowed	One reversal is allowed (if a second obstacle is detected during a power open or close operation, the door reverts to manual mode).

AUTOMATIC BACK DOOR SYSTEM

Schematic

EIS008R5

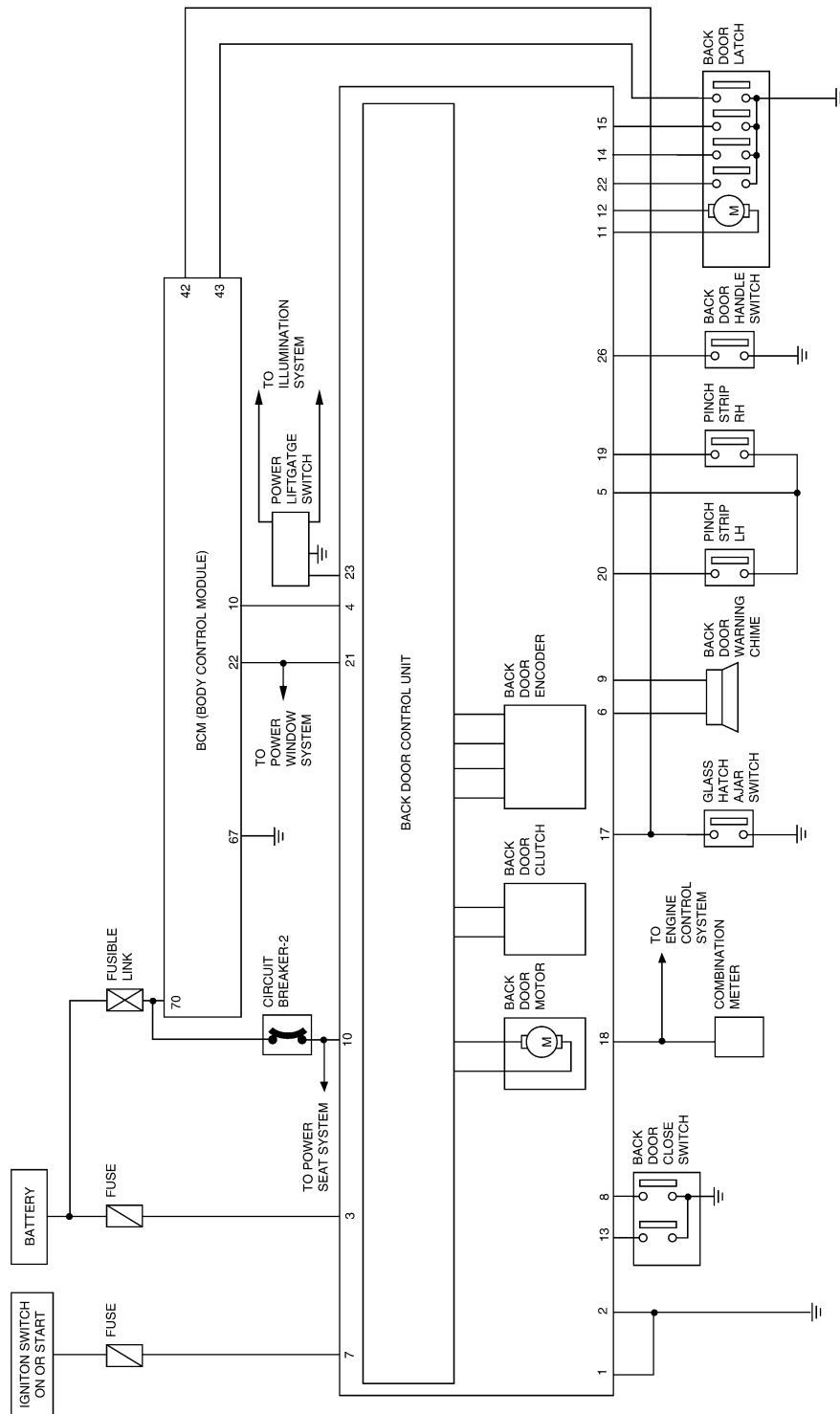

A
B
C
D
E
F
G
H
BL
J
K
L
M

WIWA1741E

AUTOMATIC BACK DOOR SYSTEM

EIS008R6

Wiring Diagram — B/CLOS —

BL-B/CLOS-01

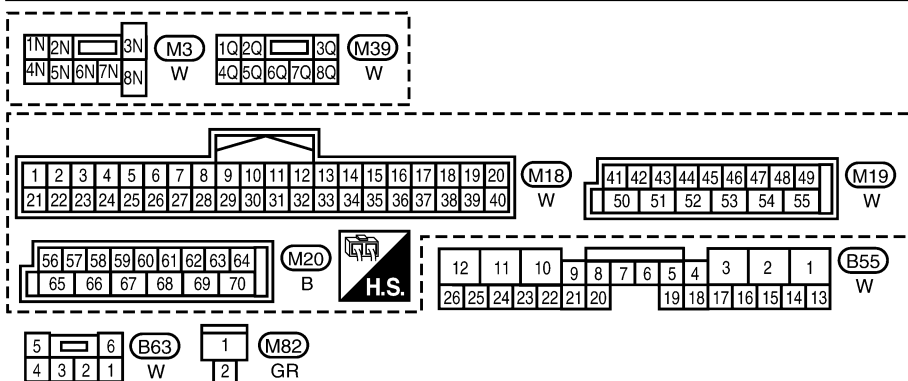
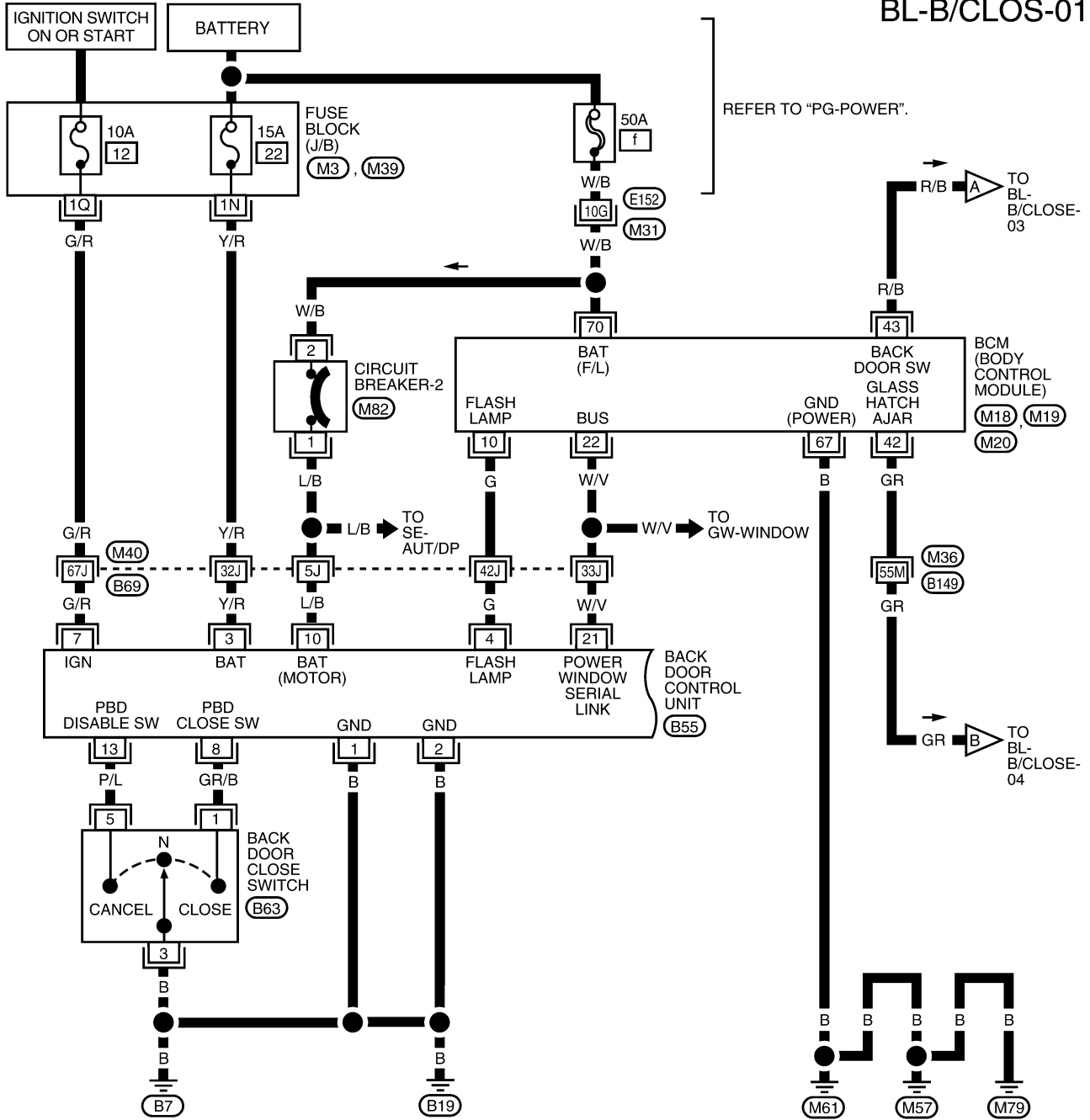

REFER TO THE FOLLOWING.
 (M31), (M36), (M40)
 - SUPER
 MULTIPLE JUNCTION (SMJ)

WIWA1314E

AUTOMATIC BACK DOOR SYSTEM

BL-B/CLOS-02

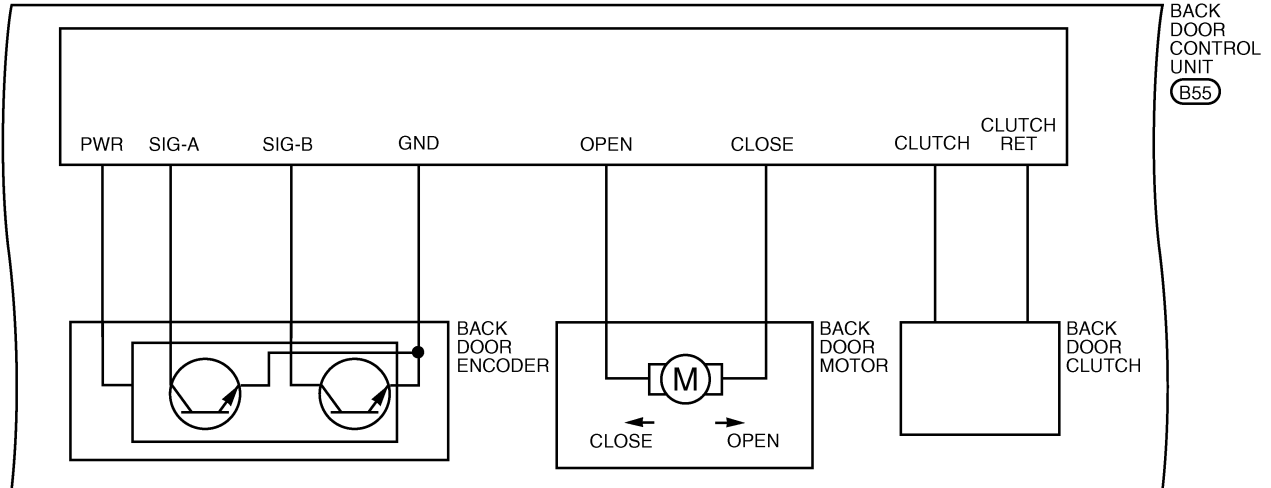

A
B
C
D
E
F
G
H
J
K
L
M

BL

WIWA0174E

AUTOMATIC BACK DOOR SYSTEM

BL-B/CLOS-03

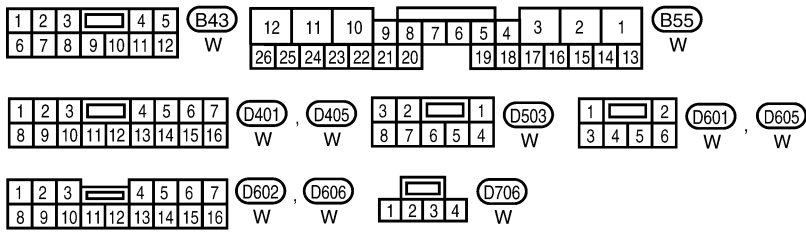
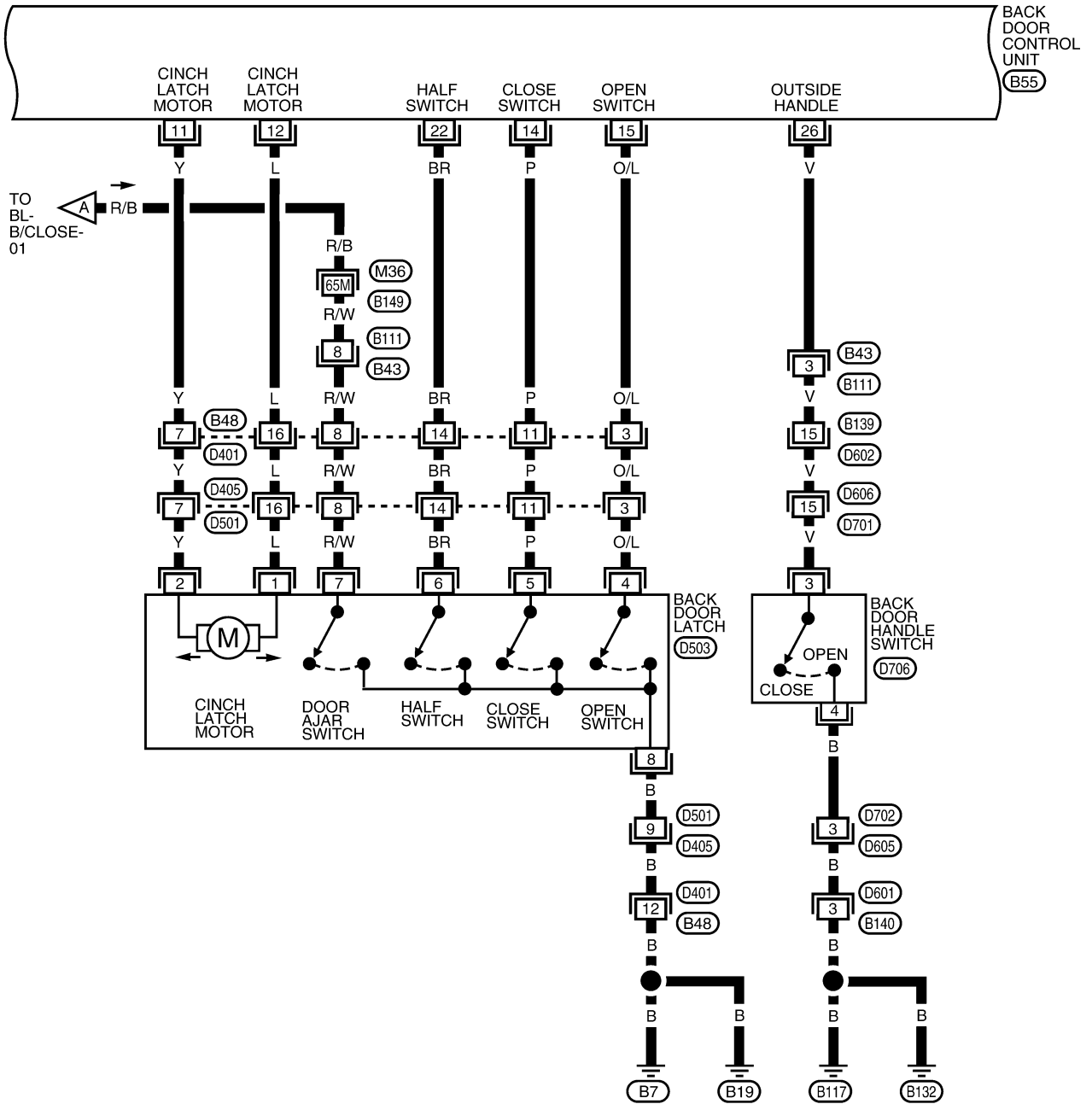

REFER TO THE FOLLOWING.
(M36) - SUPER MULTIPLE JUNCTION (SMJ)

WIWA1315E

AUTOMATIC BACK DOOR SYSTEM

BL-B/CLOS-04

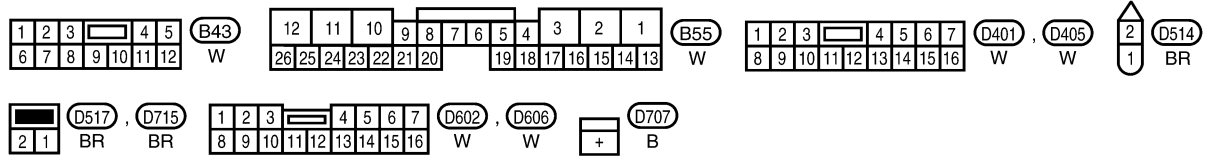
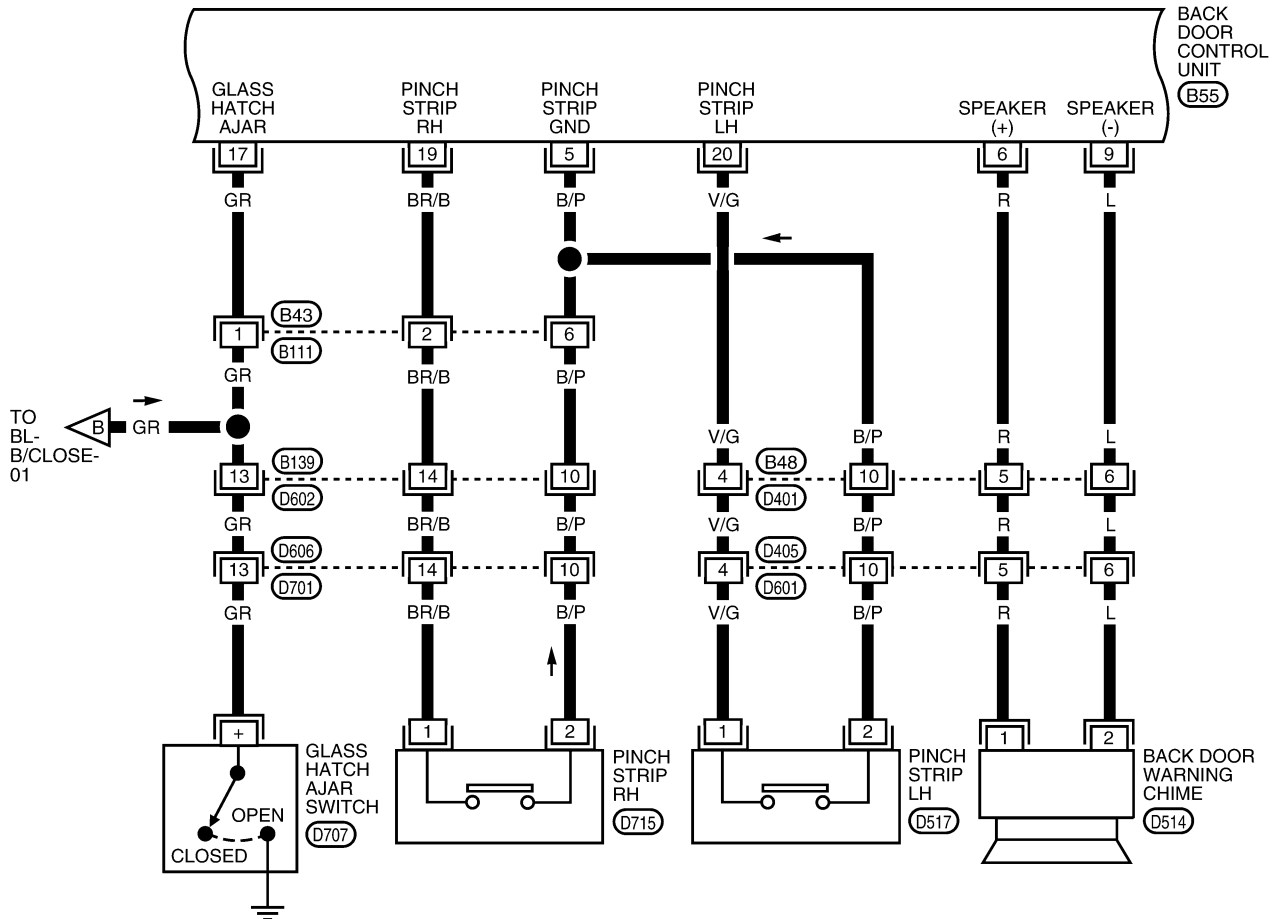

W1WA1316E

AUTOMATIC BACK DOOR SYSTEM

BL-B/CLOS-05

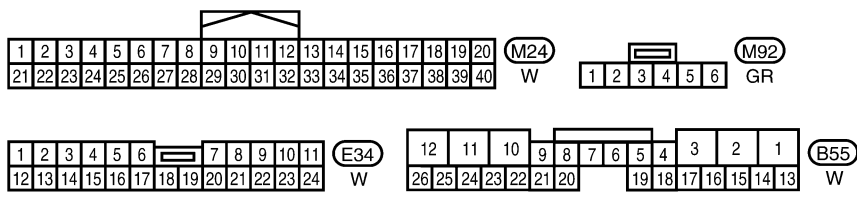
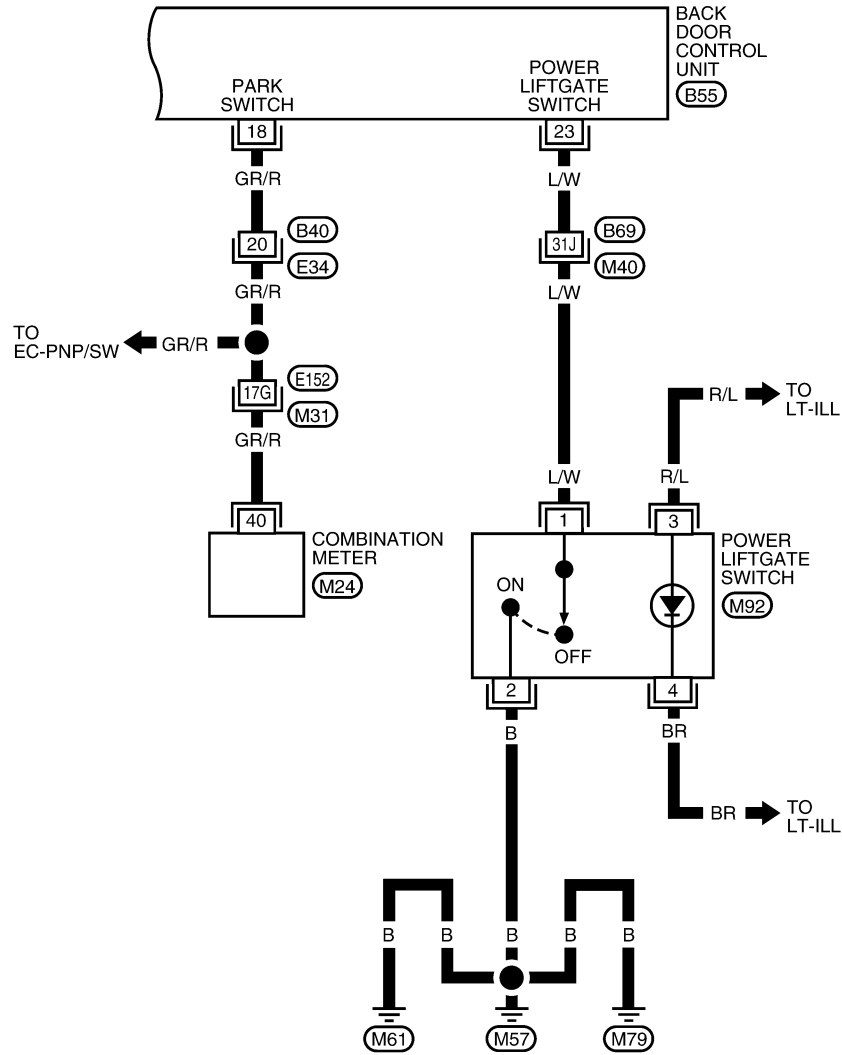

REFER TO THE FOLLOWING.
 (M31), (M40) - SUPER
 MULTIPLE JUNCTION (SMJ)

WIWA1317E

AUTOMATIC BACK DOOR SYSTEM

Terminals and Reference Value for Back Door Control Unit

EIS008R7

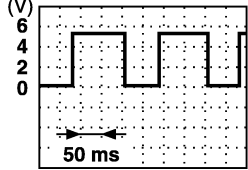
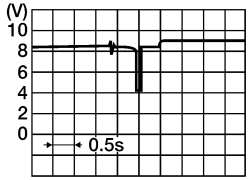
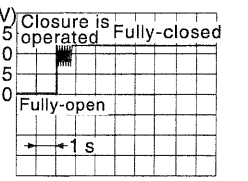
Terminal	Wire Color	Item	Condition	Voltage (V) (Approx.)
1	B	Ground	—	—
2	B	Ground	—	—
3	Y/R	Battery power supply	—	Battery voltage
4	G	Hazard lamp output	Request to flash hazards	Pulse must be >50ms but less than 250ms  PIIA3278E
5	B/P	Pinch strip ground	—	—
6	R	Warning chime output	Back door motor active	Battery voltage
7	G/R	Ignition switch	Ignition switch ON	Battery voltage
			Ignition switch OFF	0
8	GR/B	Back door close switch	CLOSE position (ON)	0
			NEUTRAL position (OFF)	Battery voltage
9	L	Warning chime ground	—	—
10	L/B	Battery power supply	—	Battery voltage
11	Y	Cinch latch motor CLOSE output	Back door close operation	Battery voltage
12	L	Closure motor RETURN output	Back door release operation	Battery voltage
13	P/L	Back door close switch (While operating back door)	CANCEL position (ON)	0
			NEUTRAL position (OFF)	9
14	P	Close switch signal	While fully opening back door	 WIIA1047E
15	O/L	Open switch signal	While fully closing back door	 PIIA2171E
17	GR	Glass hatch ajar signal	Glass hatch OPEN	0
			Glass hatch CLOSED	5
18	GR/R	Park switch	P or N position (Ignition is ON)	0
			Other (Ignition is ON)	9
19	BR/B	Pinch strip RH	Detecting obstruction	0
			Other	4
20	V/G	Pinch strip LH	Detecting obstruction	0
			Other	4

A
B
C
D
E
F
G
H
J
K
L
M

BL

AUTOMATIC BACK DOOR SYSTEM

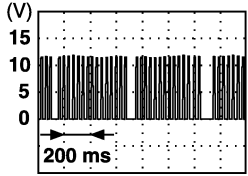
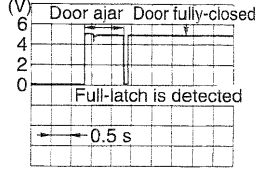
Terminal	Wire Color	Item	Condition	Voltage (V) (Approx.)
21	W/V	Power window serial link	—	 PIIA2344E
22	BR	Half switch signal	Back door half latch position	 PIIA2169E
23	L/W	Power liftgate switch	ON	0
			OFF	Battery voltage
26	V	Back door outside handle signal	Back door handle switch (at rest)	Battery voltage
			Back door handle switch (open)	0

Terminals and Reference Value for BCM

EIS008R8

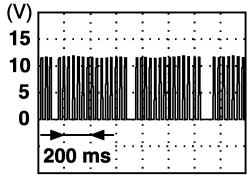
Terminal	Wire Color	Item	Condition	Voltage (V) (Approx.)
10	G	Hazard lamp flash input	Back door active	0
			Other	5
22	W/V	Bus	—	 PIIA2344E
42	GR	Glass hatch ajar switch	Open	0
			Closed	5
43	R/B	Back door latch (door ajar switch)	Open	0
			Closed	5
67	B	Ground	—	0
70	W/B	Battery power supply	—	Battery voltage

AUTOMATIC BACK DOOR SYSTEM

Trouble Diagnosis Procedure

EIS008R9

1. Check the trouble symptom and customer's requests.
2. Understand outline of system. Refer to [BL-45, "System Description"](#) .
3. Confirm system operation.
4. Perform self-diagnosis procedures. Refer to [BL-113, "Self-Diagnosis Procedures"](#) .
5. Refer to diagnosis chart by symptom, repair or replace any malfunctioning parts. Refer to [BL-114, "Diagnosis Chart"](#) .
6. Inspection End.

Self-Diagnosis Procedures INPUT SIGNAL CHECK MODE

EIS008RA

Input signal check mode allows testing of switch input signal to the back door control unit. To activate input signal check mode on the automatic back door, perform the following steps:

1. Turn ignition switch OFF.
2. Turn back door close switch to CANCEL (system cancelled).
3. Place A/T selector lever in P position.
4. Using the inside emergency release lever, open the back door.
5. Have an assistant press and hold the back door handle switch.
6. While the assistant continues to hold the back door handle switch, turn ignition switch ON (DO NOT start engine).
7. After approximately 5 seconds, the back door warning chime will sound for 0.5 seconds.
8. Release the back door handle switch.
9. Within 8 seconds of the back door warning chime sounding, press and hold the power liftgate switch.
10. After approximately 5 seconds, the back door warning chime will sound for 1 second.
11. Release the power liftgate switch.
12. The input signal check mode is now initialized.

The input signal check mode can test the following inputs. The back door warning chime will sound for approximately 0.5 seconds each time a switch signal input occurs. Use this test when one of these inputs is not responding during normal automatic back door operation.

Switch signal	Operation	Refer to
Power liftgate switch	OFF → ON	BL-116
Back door close switch (CLOSE)	OFF → ON	BL-118
Back door close switch (CANCEL)	OFF → ON	BL-119
Back door handle switch	OFF → ON	BL-125
Glass switch	OFF → ON	BL-117
A/T device (park switch)	P position → other than P position	AT-60
Vehicle speed*	Vehicle speed	—
Remote keyless entry signal	Keyfob switch OFF → ON	BL-44
Door lock/unlock signal	LOCK → UNLOCK	BL-16
Pinch strip LH signal	OFF → ON	BL-121
Pinch strip RH signal	OFF → ON	BL-121

*Back door warning chime should sound as soon as vehicle moves.
Turn ignition switch OFF to end input signal check mode.

OPERATING CHECK MODE

Operating check mode allows self-diagnosis of the automatic back door system. To activate operating check mode on the automatic back door, perform the following steps:

1. Turn ignition switch OFF.
2. Turn back door close switch to CANCEL (system cancelled).
3. Place A/T selector lever in P position.

AUTOMATIC BACK DOOR SYSTEM

4. Using the inside emergency release lever, open the back door.
5. Have an assistant press and hold the back door handle switch.
6. While the assistant continues to hold the back door handle switch, turn ignition switch ON (DO NOT start engine).
7. After approximately 5 seconds, the back door warning chime will sound for 0.5 seconds.
8. Release the back door handle switch.
9. Within 8 seconds of the back door warning chime sounding, press the power liftgate switch 5 times in rapid succession.
10. After approximately 5 seconds, the back door warning chime will sound for 1 second.
11. Release the power liftgate switch.
12. Immediately close the back door manually.
13. Press and release the power liftgate switch to activate operating check mode.

Self-diagnosis results are indicated by the back door warning chime.

Back door warning chime order	Back door warning chime length	
Start self-diagnosis	1.5 seconds	
	OK	NG
1. Operating conditions diagnosis	0.5 seconds	0.2 seconds
2. Back door encoder diagnosis	0.5 seconds	0.2 seconds
3. Back door clutch diagnosis	0.5 seconds	0.2 seconds
4. Back door motor diagnosis	0.5 seconds	0.2 seconds
5. Cinch latch motor diagnosis	0.5 seconds	0.2 seconds
Restart self-diagnosis	1.5 seconds	

Item	NG Result	Refer to
1. Operating conditions diagnosis result	One of the following operating conditions no longer met: ignition switch ON, back door close switch (CANCEL) ON, A/T selector lever in P position	—
2. Back door encoder diagnosis result	Sensor diagnosis/short, pulse signal, pulse signal direction	BL-135
3. Back door clutch diagnosis result	Back door clutch does not operate	BL-135
4. Back door motor diagnosis result	Back door motor does not operate (no operating current)	BL-135
5. Cinch latch motor diagnosis result	Cinch latch motor does not operate (no operating current)	BL-135

Turn ignition switch OFF to end input signal check mode.

Diagnosis Chart

EIS008RB

Symptom	Suspect systems	Refer to
Automatic operations are not executed from the back door fully closed or fully open position. (Auto closure operates normally.)	Power liftgate switch system inspection	BL-116
	Park switch	—
	Power window serial link	BL-112
	Pinch strip system inspection	BL-121
Automatic operations are not carried out together with open/close operations. (Manual operations are normal.)	Power liftgate switch system inspection	BL-116
	Back door close switch system inspection	BL-118
	Auto back door power supply and ground circuit system inspection.	BL-115
The auto closure function does not operate. (Stops at the halfway position for auto closing operations.)	Pinch strip system inspection	BL-121

AUTOMATIC BACK DOOR SYSTEM

Symptom	Suspect systems	Refer to
During auto closing operations, if obstruction is detected, the door does not operate in reverse.	Back door motor assembly	—
During close or cinch operations, the door does not operate in reverse if the back door handle is operated.	Handle switch system	BL-125
When the keyfob is operated, the back door does not operate automatically.	Remote keyless entry system inspection	BL-44
	Power window serial link	BL-112
	Pinch strip system inspection	BL-121
Auto closure does not operate.	Half-latch switch system	BL-122
	Cinch latch motor system	BL-126
	Handle switch system	BL-125
The back door does not open. (Closure motor rotation is not reversed.)	Open switch system	BL-123
	Handle switch system	BL-125
Warning chime does not sound.	Back door warning chime system	BL-122
Auto closure operation works, but the back door is not fully closed	Close switch system	BL-124
	Handle switch system	BL-125
	Cinch latch motor system	BL-126
	Back door latch assembly mechanism damaged or worn.	—

Back Door Power Supply and Ground Circuit Inspection

EIS008RC

1. BACK DOOR POWER SUPPLY CIRCUIT INSPECTION

- Turn ignition switch OFF.
- Disconnect back door control unit.
- Check voltage between back door control unit connector B55 terminals 3, 10 and ground.

3 - Ground : Approx. battery voltage
10 - Ground : Approx. battery voltage

OK or NG

- OK >> GO TO 2.
 NG >> Repair or replace harness.

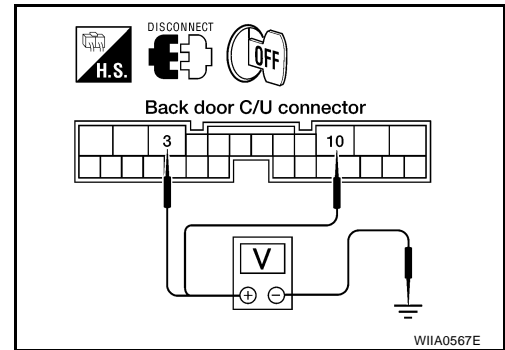

2. BACK DOOR GROUND CIRCUIT INSPECTION

Check continuity between back door control unit connector B55 terminal 1, 2 and ground.

1 - Ground : Continuity should exist.
2 - Ground : Continuity should exist.

OK or NG

- OK >> Circuit is OK.
 NG >> Repair or replace harness.

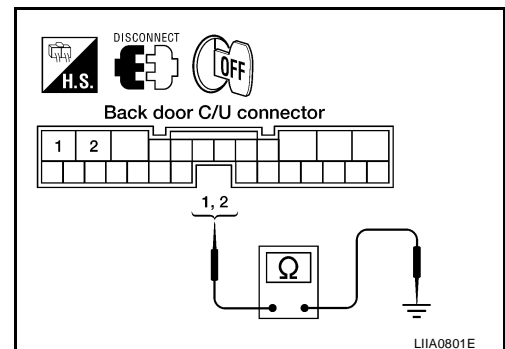

AUTOMATIC BACK DOOR SYSTEM

EIS008RD

Power Liftgate Switch System Inspection

1. POWER LIFTGATE SWITCH FUNCTION INSPECTION

Check power liftgate switch using switch operation.

OK or NG

- OK >> Power liftgate switch is OK.
- NG >> GO TO 2.

2. POWER LIFTGATE SWITCH POWER SUPPLY CIRCUIT INSPECTION

1. Turn ignition switch OFF.
2. Check voltage between power liftgate switch connector M92 terminal 1 and ground.

1 - Ground : **Approx. battery voltage**

OK or NG

- OK >> GO TO 3.
- NG >> Repair or replace harness.

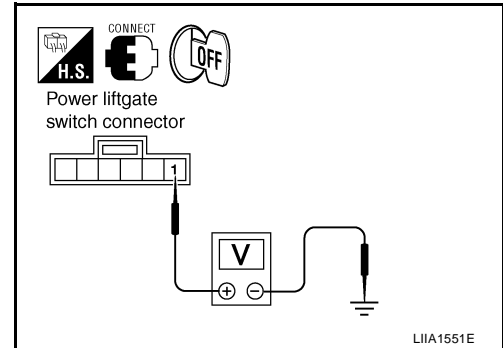

3. POWER LIFTGATE SWITCH SIGNAL INSPECTION

1. Turn ignition switch OFF.
2. While operating the power liftgate switch, check voltage between back door control unit connector B55 terminal 23 and ground.

Terminals		Condition		Voltage (V) (Approx.)
(+)	(-)			
23	Ground	Power liftgate switch	ON	0
			OFF	Battery voltage

OK or NG

- OK >> Switch is OK.
- NG >> GO TO 4.

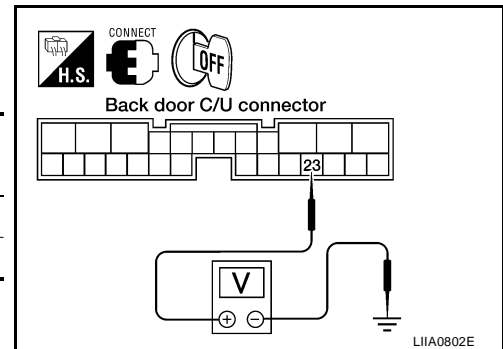

4. POWER LIFTGATE SWITCH CIRCUIT INSPECTION

1. Disconnect power liftgate switch and back door control unit connector.
2. Check continuity between power liftgate switch connector M92 terminal 1 and back door control unit connector B55 terminal 23.

1 - 23 : **Continuity should exist.**

OK or NG

- OK >> GO TO 5.
- NG >> Repair or replace harness.

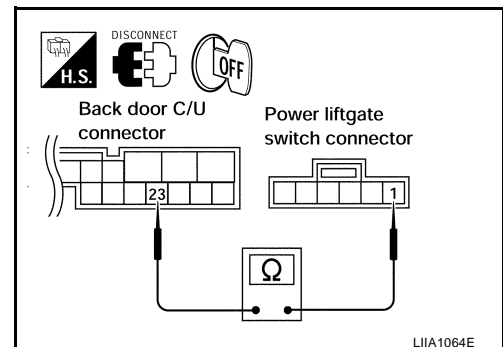

AUTOMATIC BACK DOOR SYSTEM

5. POWER LIFTGATE SWITCH GROUND INSPECTION

Check continuity between power liftgate switch connector terminal 2 and ground.

2 - Ground : Continuity should exist.

OK or NG

- OK >> Replace the power liftgate switch.
- NG >> Repair or replace harness.

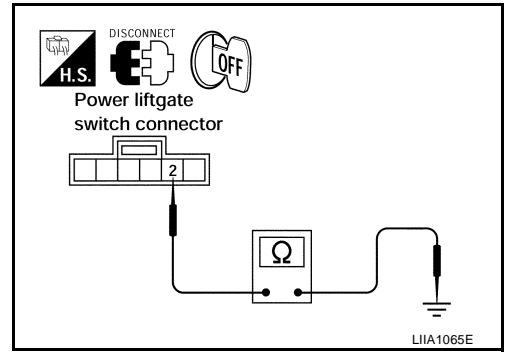

GLASS HATCH AJAR SWITCH CHECK

1. CHECK GLASS HATCH AJAR SWITCH INPUT SIGNAL

With CONSULT-II

Check glass hatch ajar switch ("TRNK OPN MNTR") in DATA MONITOR mode with CONSULT-II. Refer to [BL-27, "DATA MONITOR"](#).

- When glass hatch is open:
TRNK OPN MNTR : ON
- When glass hatch is closed:
TRNK OPN MNTR : OFF

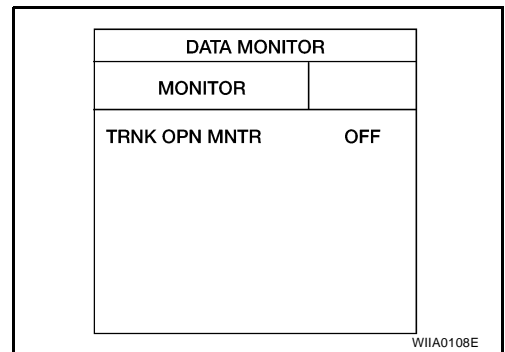

Without CONSULT-II

Check voltage between BCM connector M19 terminal 42 and ground.

Connector	Item	Terminals		Condition	Voltage (V) (Approx.)
		(+)	(-)		
M19	BCM	42	Ground	Open ↓ Closed	0 ↓ Battery voltage

OK or NG

- OK >> System is OK.
- NG >> GO TO 2.

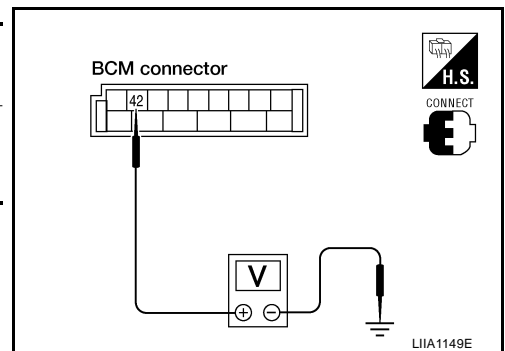

AUTOMATIC BACK DOOR SYSTEM

2. CHECK GLASS HATCH AJAR SWITCH CIRCUIT

1. Turn ignition switch OFF.
2. Disconnect glass hatch ajar switch, BCM and back door control unit.
3. Check continuity between glass hatch ajar switch connector D707 terminal + and BCM connector M19 terminal 42.

+ - 42 : Continuity should exist

4. Check continuity between glass hatch ajar switch connector D707 terminal + and back door control unit connector B55 terminal 17.

+ - 17 : Continuity should exist

5. Check continuity between glass hatch ajar switch connector D707 terminal + and ground.

+ - Ground : Continuity should not exist

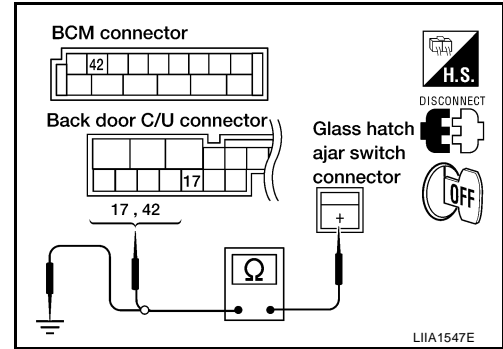

OK or NG

- OK >> GO TO 3.
- NG >> Repair or replace harness.

3. CHECK GLASS HATCH AJAR SWITCH

1. Disconnect glass hatch ajar switch connector.
2. Check continuity between glass hatch ajar switch connector terminal and ground.

	Terminals	Condition	Continuity
Glass hatch ajar switch	+ - Ground	Open	Yes
		Closed	No

OK or NG

- OK >> Check glass hatch ajar switch case ground condition.
- NG >> Replace glass hatch ajar switch, or repair or replace harness.

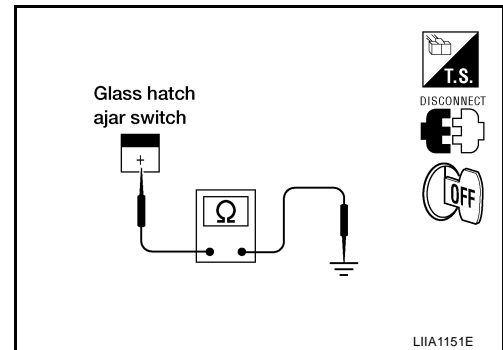

Back Door Close (Close) Switch System Inspection

EIS008RE

1. BACK DOOR CLOSE SWITCH FUNCTION INSPECTION

Check back door close (close) switch using switch operation.

OK or NG

- OK >> Back door close switch is OK.
- NG >> GO TO 2.

AUTOMATIC BACK DOOR SYSTEM

2. BACK DOOR CLOSE SWITCH SIGNAL INSPECTION

1. Turn ignition switch OFF.
2. While operating the back door close switch, check voltage between back door control unit connector B55 terminal 8 and ground.

Terminals		Condition	Voltage (V) (Approx.)
(+)	(-)		
8	Ground	Back door close switch ON	0
		Back door close switch OFF	Battery voltage

OK or NG

- OK >> Back door close switch is OK.
- NG >> GO TO 3.

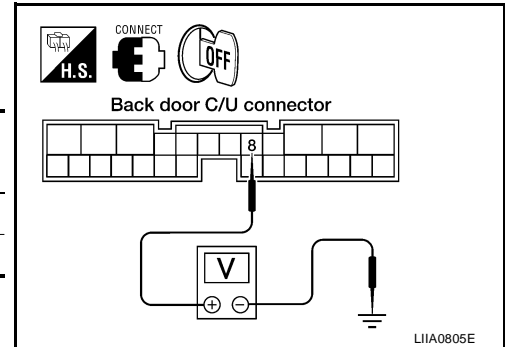

3. BACK DOOR CLOSE SWITCH CIRCUIT INSPECTION

1. Disconnect back door close switch and back door control unit connector.
2. Check continuity between back door close switch connector B63 terminal 1 and back door control unit connector B55 terminal 8.

1 - 8 : Continuity should exist.

OK or NG

- OK >> GO TO 4.
- NG >> Repair or replace harness.

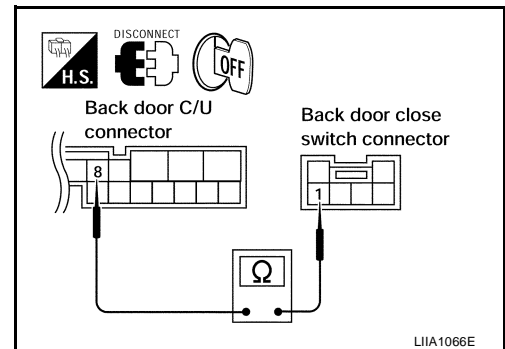

4. BACK DOOR CLOSE SWITCH GROUND INSPECTION

Check continuity between back door close switch connector B63 terminal 3 and ground.

3 - Ground : Continuity should exist.

OK or NG

- OK >> Replace the back door close switch.
- NG >> Repair or replace harness.

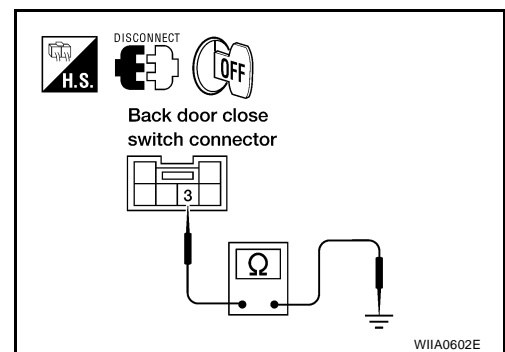

Back Door Close (Cancel) Switch System Inspection

EIS008RF

1. BACK DOOR CLOSE SWITCH FUNCTION INSPECTION

Check back door close (cancel) switch using switch operation.

OK or NG

- OK >> Back door close switch is OK.
- NG >> GO TO 2.

AUTOMATIC BACK DOOR SYSTEM

2. BACK DOOR CLOSE (CANCEL) SWITCH SIGNAL INSPECTION

1. Turn ignition switch OFF.
2. While operating the back door close (cancel) switch, check voltage between back door control unit connector B55 terminal 13 and ground.

Terminals		Condition		Voltage (V) (Approx.)
(+)	(-)			
13	Ground	Back door close switch	Cancel (ON)	0
			Cancel (OFF)	9

OK or NG

- OK >> Back door close switch is OK.
- NG >> GO TO 3.

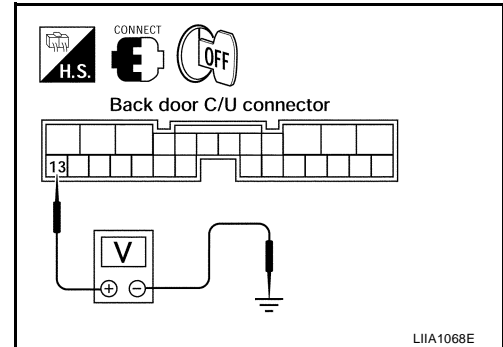

3. BACK DOOR CLOSE (CANCEL) SWITCH CIRCUIT INSPECTION

1. Disconnect back door close switch and back door control unit connector.
2. Check continuity between back door close switch connector B63 terminal 5 and back door control unit connector B55 terminal 13.

5 - 13 : Continuity should exist.

OK or NG

- OK >> GO TO 4.
- NG >> Repair or replace harness.

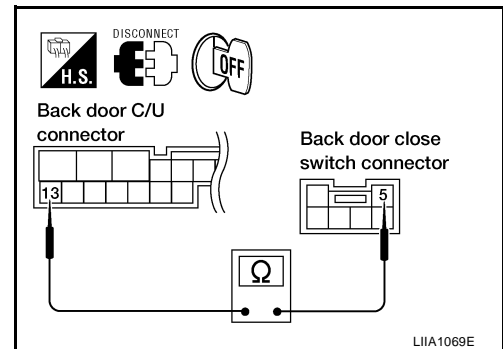

4. BACK DOOR CLOSE SWITCH GROUND INSPECTION

Check continuity between back door close switch connector B63 terminal 3 and ground.

3 - Ground : Continuity should exist.

OK or NG

- OK >> Replace the back door close switch.
- NG >> Repair or replace harness.

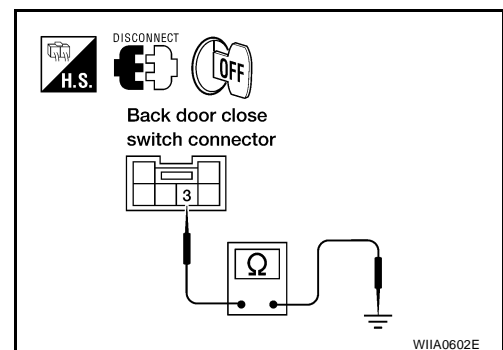

AUTOMATIC BACK DOOR SYSTEM

EIS008RG

Pinch Strip System Inspection

1. PINCH STRIP SIGNAL INSPECTION

1. Turn ignition switch OFF.
2. While operating the pinch strip, check voltage between back door control unit connector B55 terminals 19, 20 and ground.

Terminals		Condition	Voltage (V) (Approx.)
(+)	(-)		
19	Ground	Pinch strip operation	0
20		Other	4

OK or NG

- OK >> Pinch strip switch is OK.
 NG >> GO TO 2.

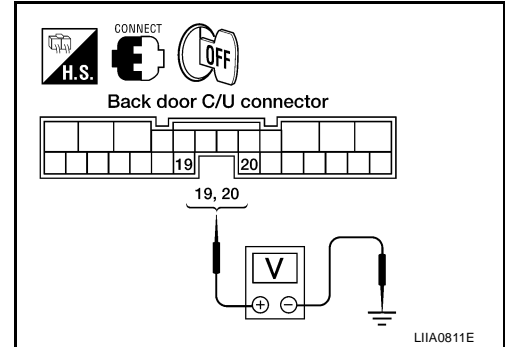

2. PINCH STRIP CIRCUIT INSPECTION

1. Disconnect pinch strip and back door control unit.
2. Check continuity between pinch strip connector D715 (RH), D517 (LH) terminal 1, 2 and back door control unit connector B55 terminal 5, 19 (RH), 20 (LH).

- 1 - 19** : Continuity should exist.
1 - 20 : Continuity should exist.
2 - 5 : Continuity should exist.

OK or NG

- OK >> GO TO 3.
 NG >> Repair the harness between the pinch strip and the back door control unit.

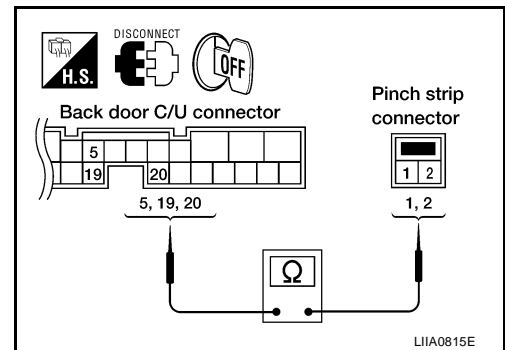

3. PINCH STRIP GROUND INSPECTION

1. Connect back door control unit connector.
2. Check continuity between pinch strip connector terminal 2 and ground.

- 2 - Ground** : Continuity should exist.

OK or NG

- OK >> Replace the pinch strip.
 NG >> Repair or replace harness.

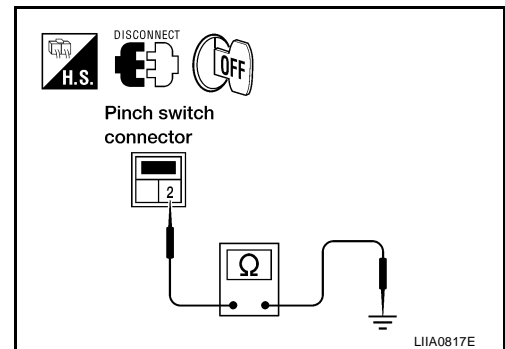

AUTOMATIC BACK DOOR SYSTEM

EIS008RH

Back Door Warning Chime System Inspection

1. BACK DOOR WARNING CHIME CIRCUIT INSPECTION

1. Disconnect back door warning chime and back door control unit.
2. Check continuity between back door warning chime connector D514 terminal 1 and back door control unit connector B55 terminal 6.

1 - 6 : Continuity should exist.

OK or NG

- OK >> GO TO 2.
 NG >> Repair or replace harness.

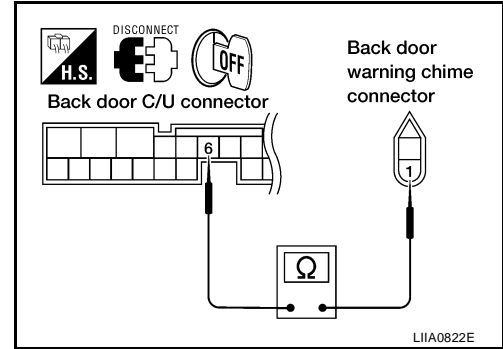

2. WARNING CHIME CIRCUIT INSPECTION

Check continuity between back door warning chime connector D514 terminal 2 and back door control unit connector B55 terminal 9.

2 - 9 : Continuity should exist.

OK or NG

- OK >> Replace warning chime.
 NG >> Repair or replace harness.

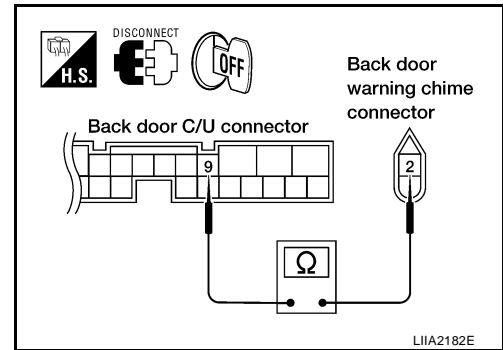

Half-Latch Switch System Inspection

EIS008RI

1. HALF-LATCH SWITCH SIGNAL INSPECTION

1. Turn ignition switch OFF.
2. While fully opening and closing the back door, check voltage between back door control unit connector B55 terminal 22 and ground.

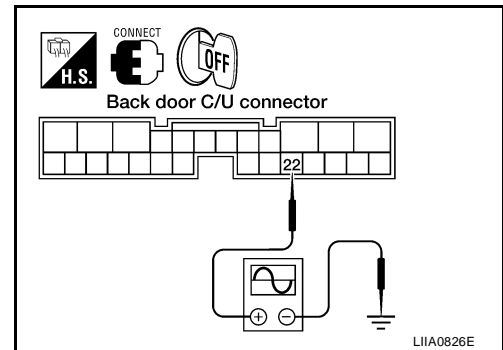
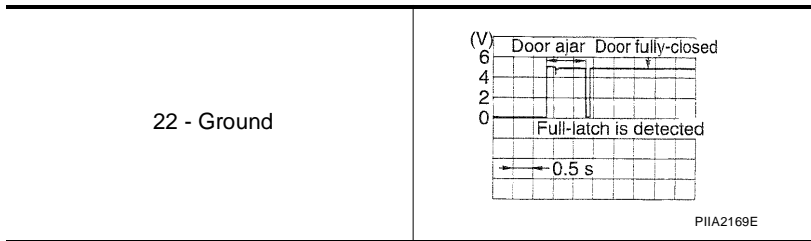

OK or NG

- OK >> Half-latch switch is OK.
 NG >> GO TO 2.

AUTOMATIC BACK DOOR SYSTEM

2. HALF-LATCH SWITCH CIRCUIT INSPECTION

1. Disconnect back door latch and back door control unit connector.
2. Check continuity between back door latch (half-latch switch) connector D503 terminal 6 and back door control unit connector B55 terminal 22.

6 - 22 : Continuity should exist.

OK or NG

- OK >> GO TO 3.
- NG >> Repair or replace harness.

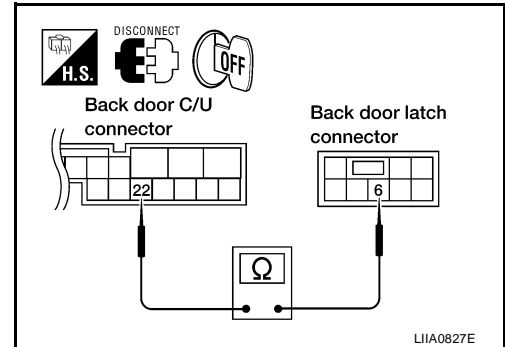

3. HALF-LATCH SWITCH GROUND INSPECTION

Check continuity between back door latch (half-latch switch) connector D503 terminal 8 and ground.

8 - Ground : Continuity should exist.

OK or NG

- OK >> Replace the back door latch.
- NG >> Repair or replace harness.

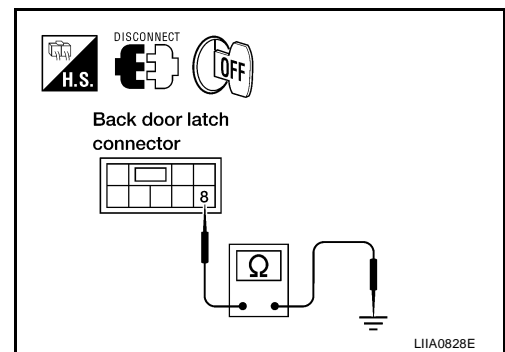

Open Switch System Inspection

1. OPEN SWITCH SIGNAL INSPECTION

1. Turn ignition switch OFF.
2. While fully closing and opening the back door, check voltage between back door control unit connector B55 terminal 15 and ground.

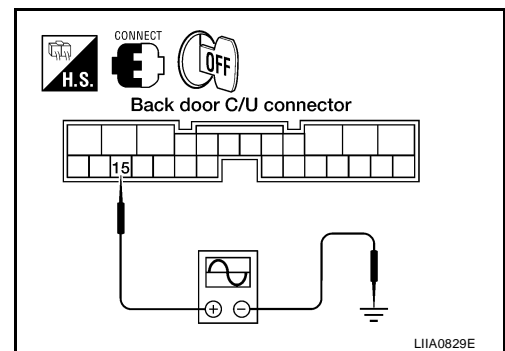
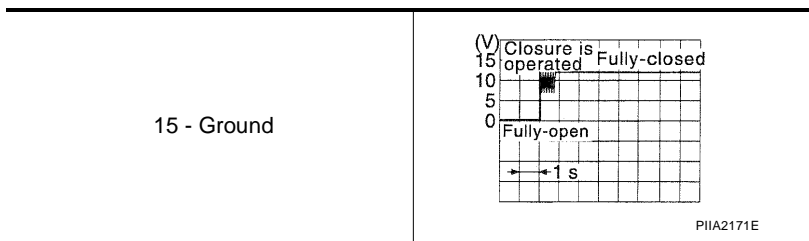

OK or NG

- OK >> Open switch is OK.
- NG >> GO TO 2.

AUTOMATIC BACK DOOR SYSTEM

2. OPEN SWITCH CIRCUIT INSPECTION

1. Disconnect back door latch and back door control unit connector.
2. Check continuity between back door latch (open switch) connector D503 terminal 4 and back door control unit connector B55 terminal 15.

4 - 15 : Continuity should exist.

OK or NG

- OK >> GO TO 3.
- NG >> Repair or replace harness.

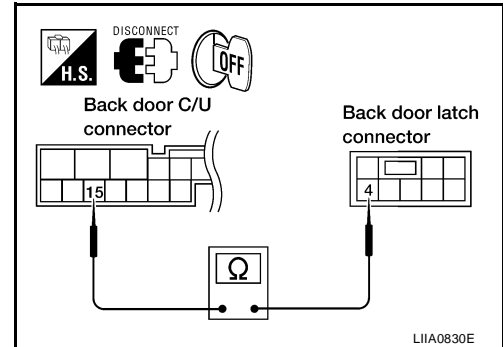

3. OPEN SWITCH GROUND INSPECTION

Check continuity between back door latch (open switch) connector D503 terminal 8 and ground.

8 - Ground : Continuity should exist.

OK or NG

- OK >> Replace the back door latch.
- NG >> Repair or replace harness.

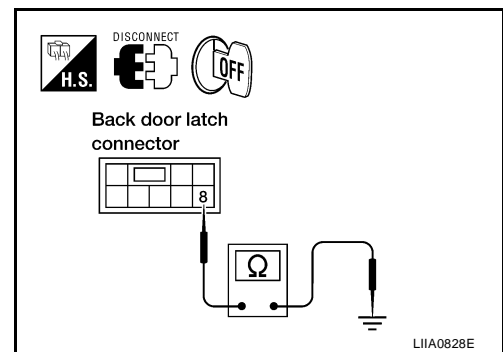

Close Switch System Inspection

1. CLOSE SWITCH SIGNAL INSPECTION

1. Turn ignition switch OFF.
2. While fully opening and closing the back door, check voltage between back door control unit connector B55 terminal 14 and ground.

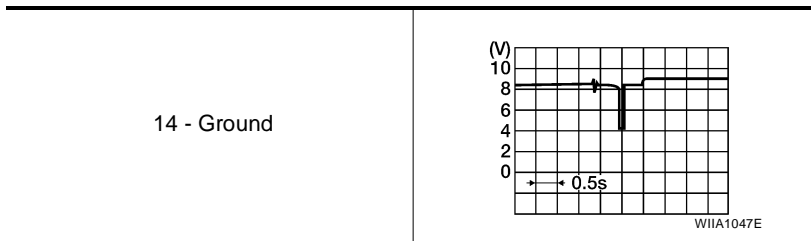

OK or NG

- OK >> Close switch is OK.
- NG >> GO TO 2.

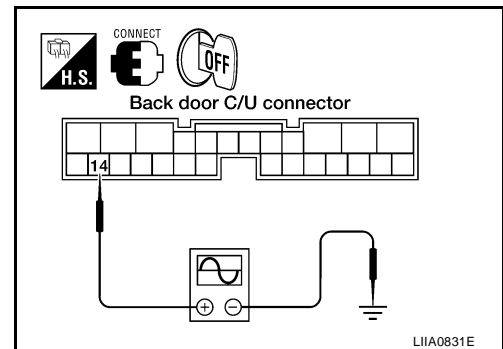

AUTOMATIC BACK DOOR SYSTEM

2. CLOSE SWITCH CIRCUIT INSPECTION

1. Disconnect back door latch and back door control unit.
2. Check continuity between back door latch (close switch) connector D503 terminal 5 and back door control unit connector B55 terminal 14.

5 - 14 : Continuity should exist.

OK or NG

- OK >> GO TO 3.
- NG >> Repair or replace harness.

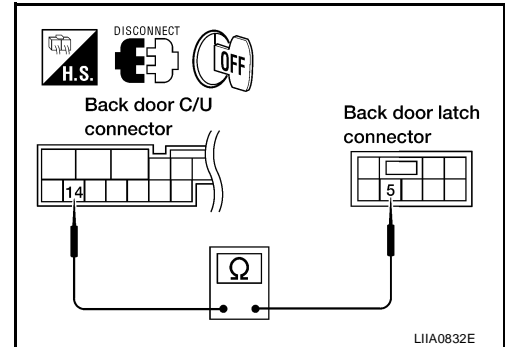

3. CLOSE SWITCH GROUND INSPECTION

Check continuity between back door latch (close switch) connector D503 terminal 8 and ground.

8 - Ground : Continuity should exist.

OK or NG

- OK >> Replace the back door latch.
- NG >> Repair or replace harness.

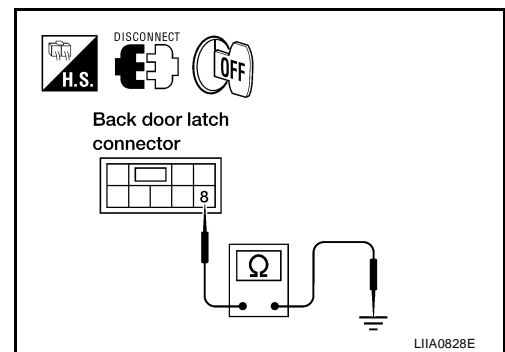

Back Door Handle Switch System Inspection

1. BACK DOOR HANDLE SWITCH SIGNAL INSPECTION

1. Turn ignition switch OFF.
2. While operating the back door handle switch, check voltage between back door control unit connector B55 terminal 26 and ground.

Terminals		Condition	Voltage (V) (Approx.)
(+)	(-)		
26	Ground	Back door handle switch (ON)	0
		Other (OFF)	Battery voltage

OK or NG

- OK >> Back door handle switch is OK.
- NG >> GO TO 2.

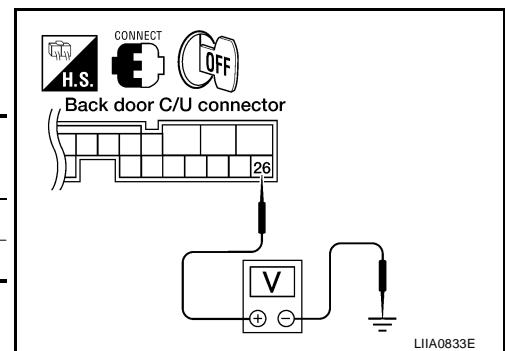

AUTOMATIC BACK DOOR SYSTEM

2. BACK DOOR HANDLE SWITCH CIRCUIT INSPECTION

1. Disconnect back door handle switch and back door control unit.
2. Check continuity between back door handle switch connector D706 terminal 3 and back door control unit connector B55 terminal 26.

3 - 26 : Continuity should exist.

OK or NG

- OK >> GO TO 4.
NG >> Repair or replace harness.

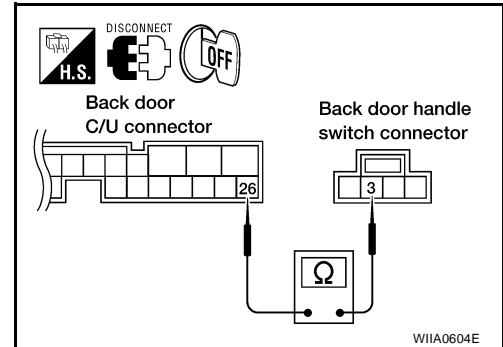

3. BACK DOOR HANDLE SWITCH GROUND INSPECTION

- Check continuity between back door handle switch connector D706 terminal 4 and ground.

4 - Ground : Continuity should exist.

OK or NG

- OK >> Replace the back door handle switch.
NG >> Repair or replace harness.

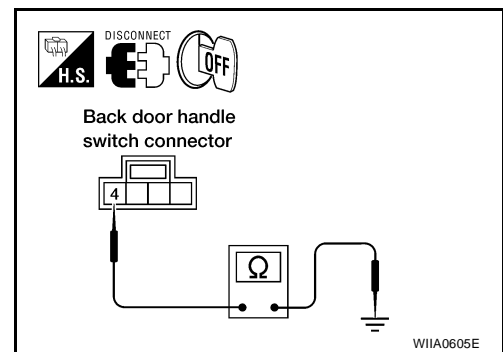

Cinch Latch Motor System Inspection

1. CINCH LATCH MOTOR SIGNAL INSPECTION

1. Turn ignition switch OFF.
2. While fully opening and closing the back door, check voltage between back door control unit connector B55 terminals 11, 12 and ground.

11 - Ground : Battery voltage.

12 - Ground : Battery voltage.

OK or NG

- OK >> GO TO 2.
NG >> Replace the back door control unit.

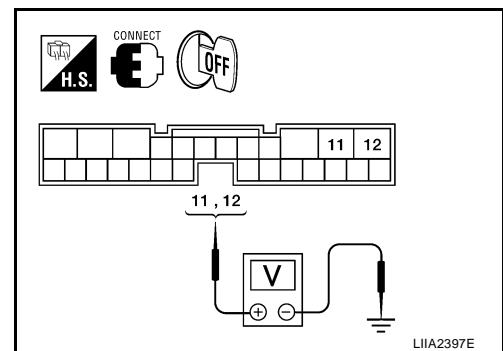

2. CINCH LATCH MOTOR CIRCUIT INSPECTION

1. Disconnect back door latch and back door control unit.
2. Check continuity between back door latch (cinch latch motor) connector D503 terminals 1, 2 and back door control unit connector B55 terminals 11, 12.

1 - 12 : Continuity should exist.

2 - 11 : Continuity should exist.

OK or NG

- OK >> GO TO 3.
NG >> Repair or replace harness.

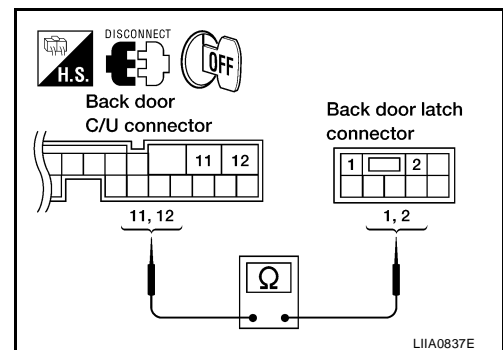

AUTOMATIC BACK DOOR SYSTEM

3. CINCH LATCH MOTOR OPERATION INSPECTION

Connect battery power to terminals 1 and 2 on the back door latch and check motor operation.

1 (+) - 2 (-) : It operates.

1 (-) - 2 (+) : It operates. (Reverse rotation)

OK or NG

OK >> Cinch latch motor is OK.

NG >> Replace the back door latch.

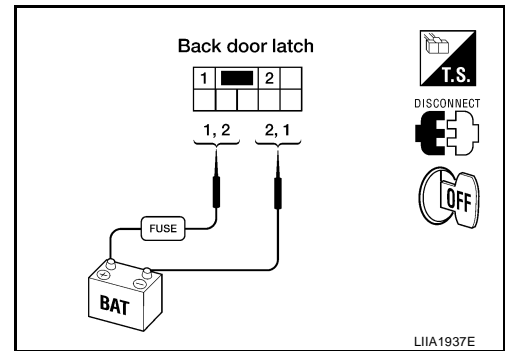

A
B
C
D
E
F
G
H
BL
J
K
L
M

DOOR

PF:80100

EIS008RN

DOOR

Fitting Adjustment

SEC. 800 • 820

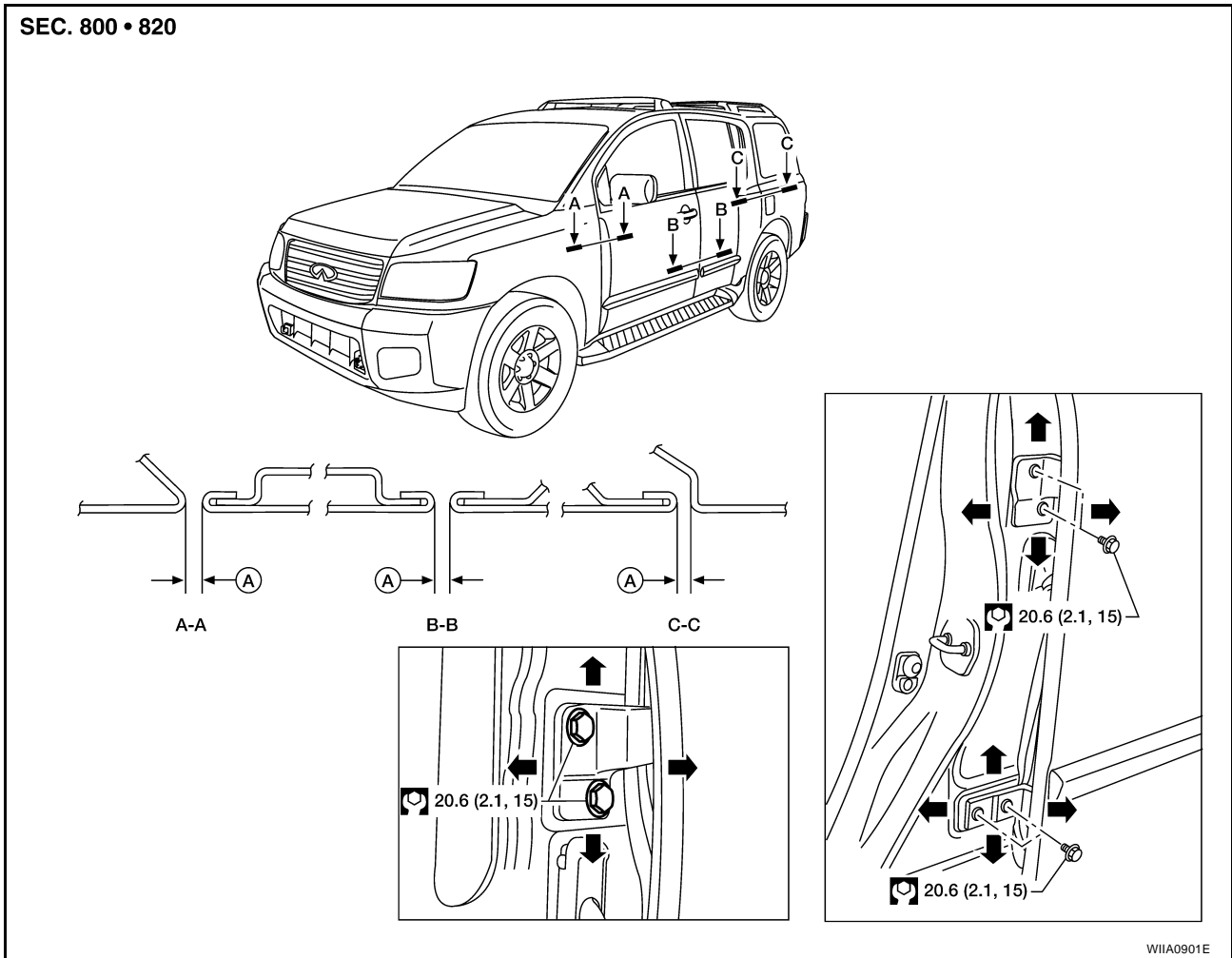

A. 4.5 ± 1.0 mm (0.177 ± 0.039 in)

WIIA0901E

FRONT DOOR

Longitudinal clearance and surface height adjustment at front end

1. Remove the fender. Refer to [EI-20, "FRONT FENDER"](#).
2. Loosen the hinge bolts. Raise the front door at rear end to adjust.
3. Install the fender. Refer to [EI-20, "FRONT FENDER"](#).

REAR DOOR

Longitudinal clearance and surface height adjustment at front end

1. Loosen the bolts. Open the rear door, and raise the rear door at rear end to adjust.

STRIKER ADJUSTMENT

1. Adjust the striker so that it becomes parallel with the lock insertion direction.

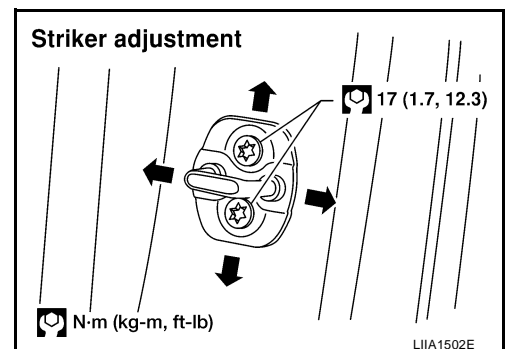

LIIA1502E

DOOR

EIS008RO

Removal and Installation

FRONT DOOR

CAUTION:

- When removing and installing the door assembly, support the door with a jack and shop cloth to protect the door and body.
 - When removing and installing door assembly, be sure to carry out the fitting adjustment.
 - Check the hinge rotating part for poor lubrication. If necessary, apply "body grease".
1. Remove the door window and module assembly. Refer to [GW-68, "FRONT DOOR GLASS AND REGULATOR"](#).
 2. Remove the door harness.
 3. Remove the check link cover.
 4. Remove the check link bolt from the hinge pillar.

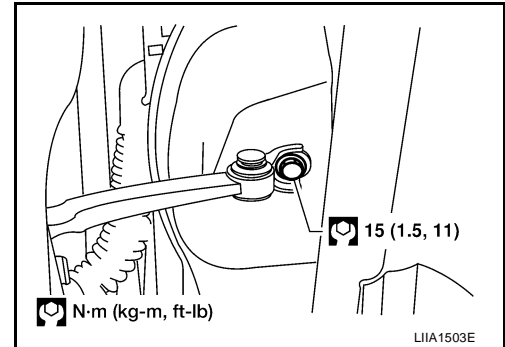

5. Remove the door-side hinge nuts and bolts, and remove the door assembly.

Installation is in the reverse order of removal.

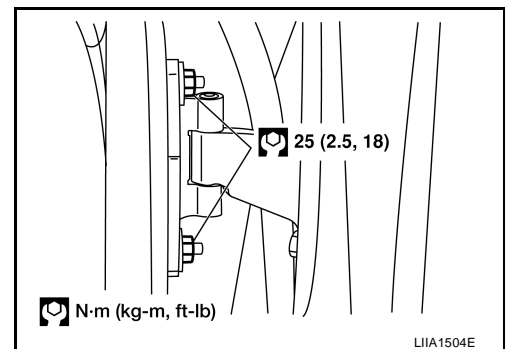

REAR DOOR

CAUTION:

- When removing and installing the door assembly, support the door with a jack and shop cloth to protect the door and body.
 - When removing and installing door assembly, be sure to carry out the fitting adjustment.
 - Check the hinge rotating part for poor lubrication. If necessary, apply "body grease".
1. Remove the door window and module assembly. Refer to [GW-71, "REAR DOOR GLASS AND REGULATOR"](#).
 2. Remove the door harness.
 3. Remove the check link cover.
 4. Remove the check link bolt from the hinge pillar.

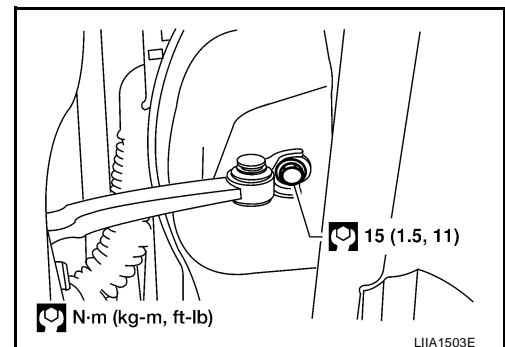

A
B
C
D
E
F
G
H
BL
J
K
L
M

DOOR

5. Remove the door-side hinge nuts and bolts, and remove the door assembly.

Installation is in the reverse order of removal.

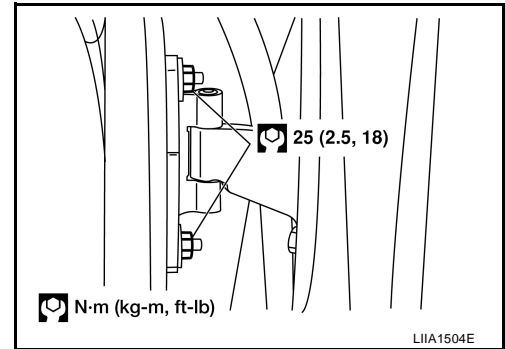

BACK DOOR

WARNING:

Always support back door when removing or replacing back door stays. Power back door opener will not support back door with back door stays removed.

1. Remove the back door glass. Refer to [GW-13, "REAR WINDOW GLASS AND MOLDING"](#) .
2. Remove the back door lock assembly. Refer to [BL-135, "BACK DOOR LOCK"](#) .
3. Remove the rear wiper motor. Refer to [WW-53, "Removal and Installation of Rear Wiper Motor"](#) .
4. Remove the back door wire harness.
5. Remove the rear washer nozzle and hose from the back door. Refer to [WW-54, "Removal and Installation of Rear Washer Nozzle"](#) .

CAUTION:

Two technicians should be used to avoid damaging the back door during removal.

6. Support the back door.
7. Disconnect the power back door lift arm from the door.
8. Remove the back door stays.
9. Remove the door side nuts and the back door assembly.

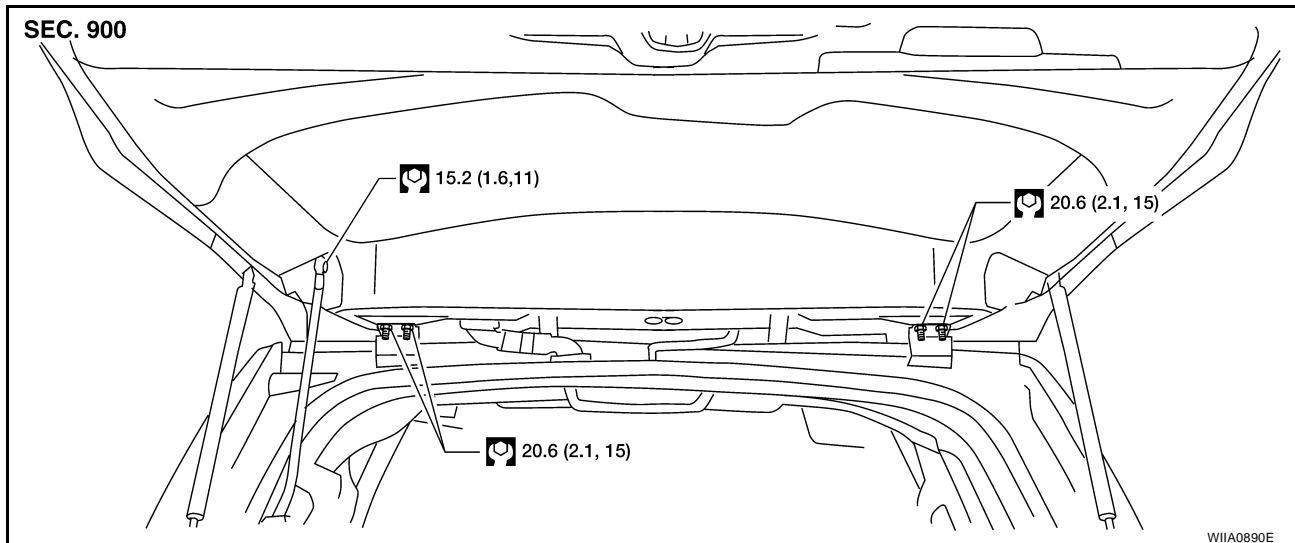

Installation is in the reverse order of removal.

FRONT DOOR LOCK

PF0:80502

EIS00629

FRONT DOOR LOCK Component Structure

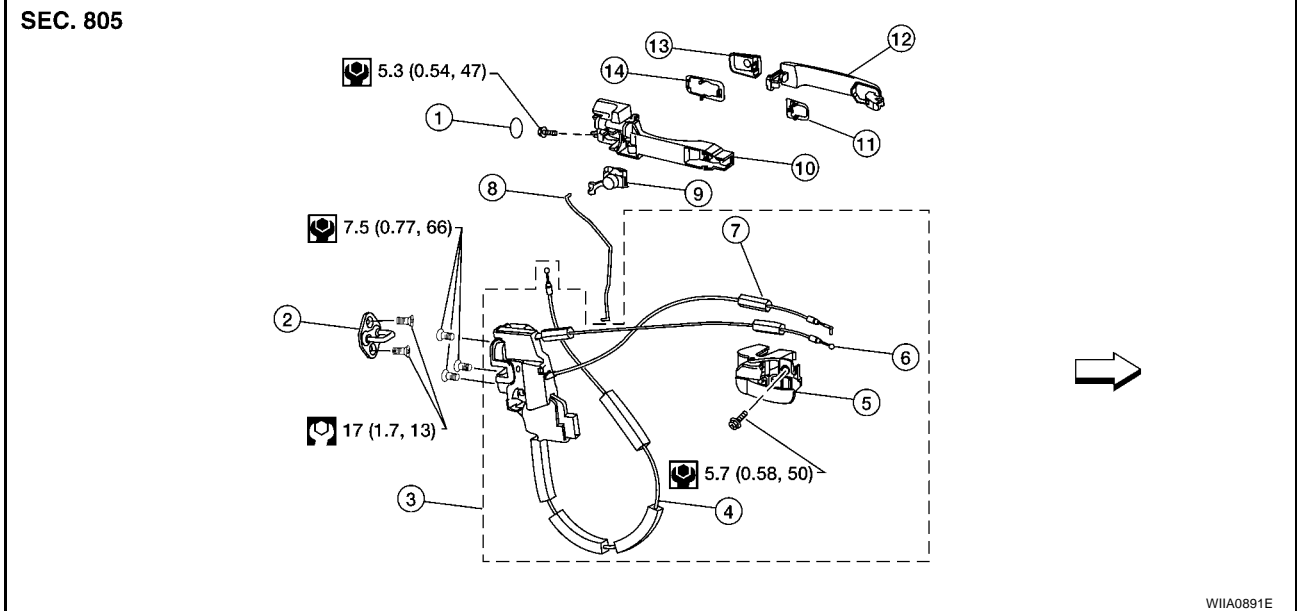

WIIA0891E

- | | | |
|---|--|------------------------|
| 1. Grommet | 2. Front door striker | 3. Door lock assembly |
| 4. Outside handle cable | 5. Inside handle assembly | 6. Inside handle cable |
| 7. Door lock cable | 8. Key cylinder rod (Driver side only) | 9. Key cylinder |
| 10. Outside handle bracket | 11. Front gasket | 12. Outside handle |
| 13. Door key cylinder assembly (Driver side) Outside handle escutcheon (Passenger side) | 14. Rear gasket | |

Removal and Installation REMOVAL

EIS0062A

- Remove front door speaker. Refer to [AV-45, "Removal and Installation of Front Door Speaker"](#).
- Remove the front door speaker housing and vapor sheet.
- Remove the door side grommet, and the bolt (TORX T30) from the grommet hole.

Torx bolt

5.3 N·m (0.54 kg·m, 47 in·lb)

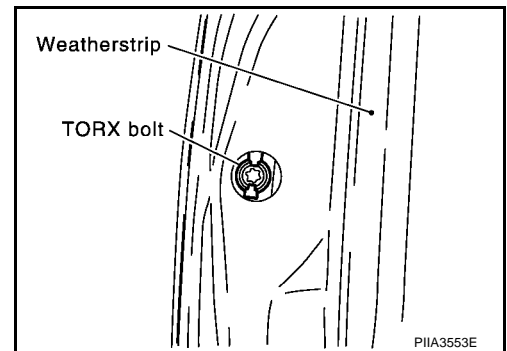

- While pulling the outside handle, remove the door key cylinder assembly or escutcheon.

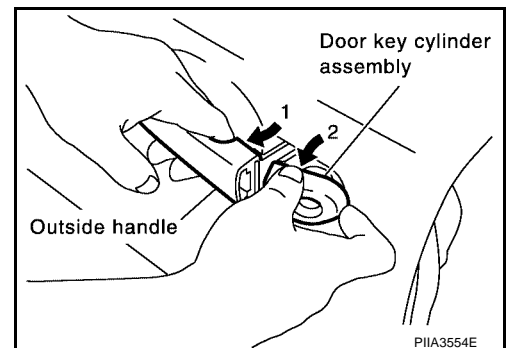

FRONT DOOR LOCK

5. Separate the key cylinder rod from the door key cylinder assembly (if equipped).
6. While pulling the outside handle, slide it toward rear of vehicle to remove.

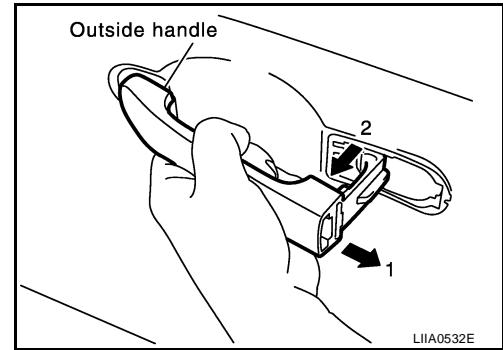

7. Remove the front and rear gaskets.

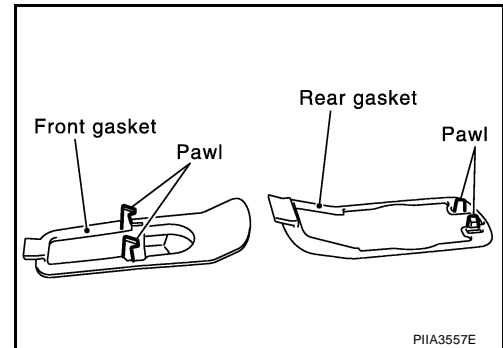

8. Remove the TORX bolts (T30), and the door lock assembly.
Door lock assembly bolts 7.5 N·m (0.77 kg·m, 00 in·lb)

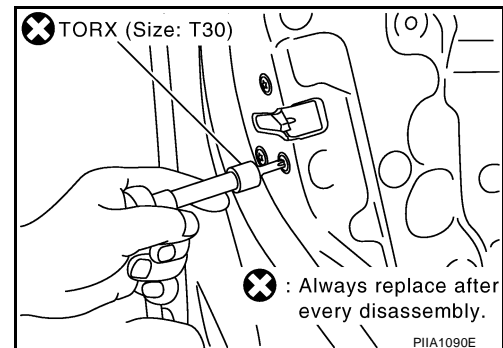

9. While pulling the outside handle bracket, slide it toward the rear of vehicle to remove it and the door lock assembly.

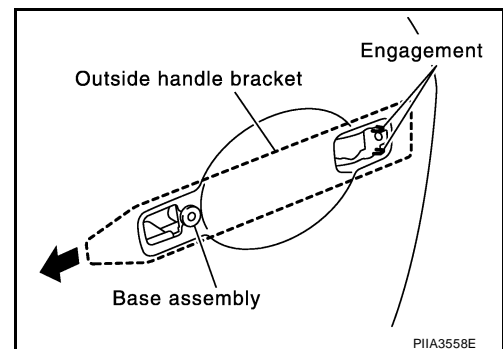

10. Disconnect the door lock actuator electrical connector.

FRONT DOOR LOCK

11. Separate the outside handle cable connection from the outside handle bracket.

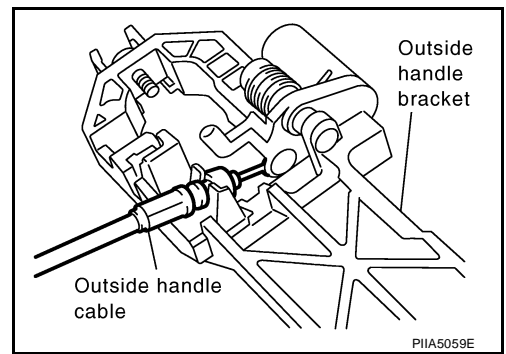

INSTALLATION

Installation in the reverse order of removal.

CAUTION:

To install each rod, be sure to rotate the rod holder until a click is felt.

Disassembly and Assembly DOOR KEY CYLINDER ASSEMBLY

EIS008RR

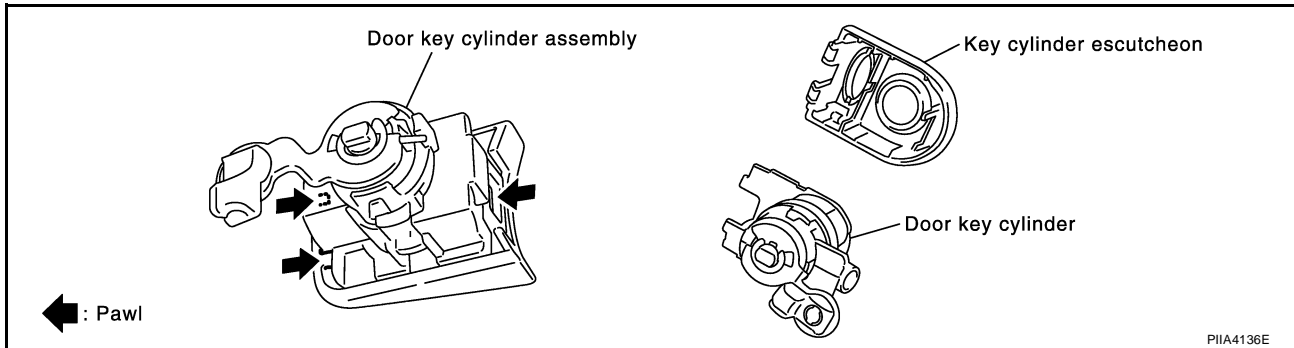

Remove the key cylinder escutcheon pawl and remove the door key cylinder.

A
B
C
D
E
F
G
H
BL
J
K
L
M

REAR DOOR LOCK

REAR DOOR LOCK

PFP:82502

Component Structure

EIS008RS

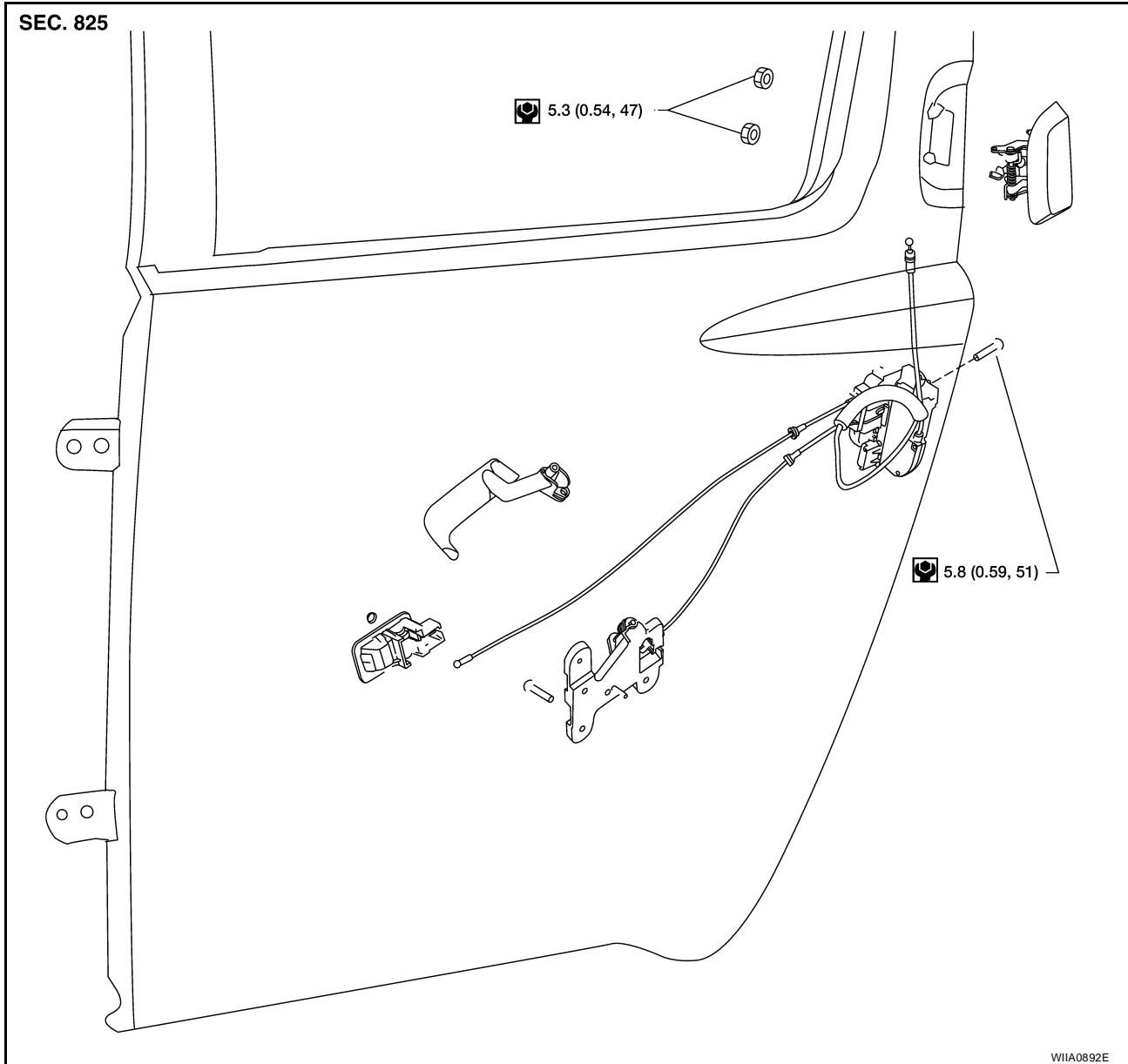

Removal and Installation

REMOVAL

EIS008RT

1. Remove the rear door window and rear door module assembly. Refer to [GW-71, "REAR DOOR GLASS AND REGULATOR"](#).
2. Remove door grommets, and remove outside handle nuts from grommet hole.
3. Remove outside handle.
4. Disconnect the door lock actuator connector.
5. Separate outside handle rod connection.

INSTALLATION

Installation is in the reverse order of removal.

BACK DOOR LOCK

PFP:90504

BACK DOOR LOCK

Power Back Door Opener REMOVAL

EIS008RU

SEC. 905

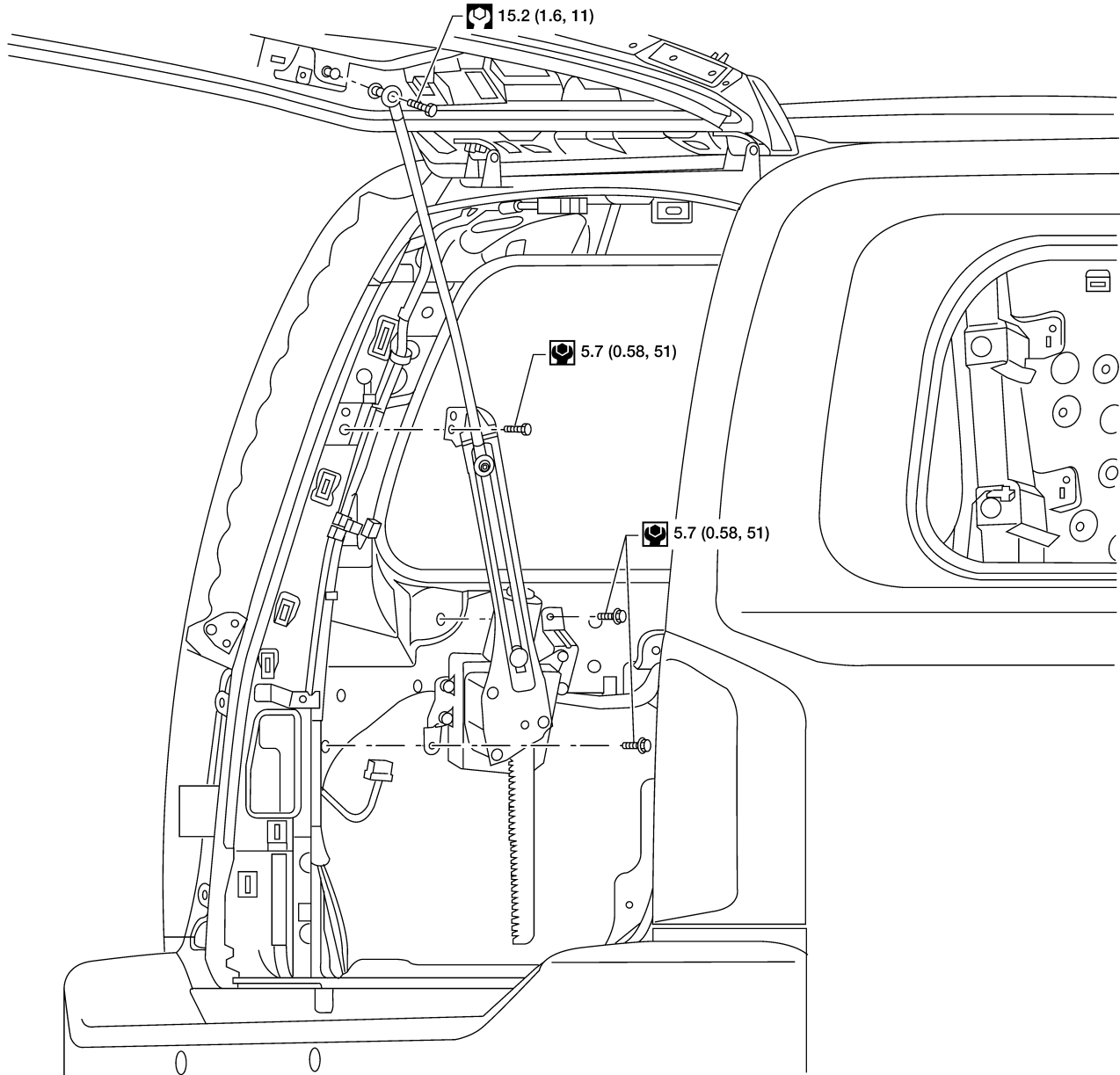

W1IA0893E

1. Remove the LH luggage side upper. Refer to [EI-40, "LUGGAGE FLOOR TRIM"](#) .
2. Disconnect the power back door motor electrical connector.
3. Disconnect the ball socket from the back door.
4. Remove the power back door motor assembly.

INSTALLATION

Installation is in the reverse order of removal.

BACK DOOR LOCK

EIS008RV

Door Lock Assembly REMOVAL

SEC. 905

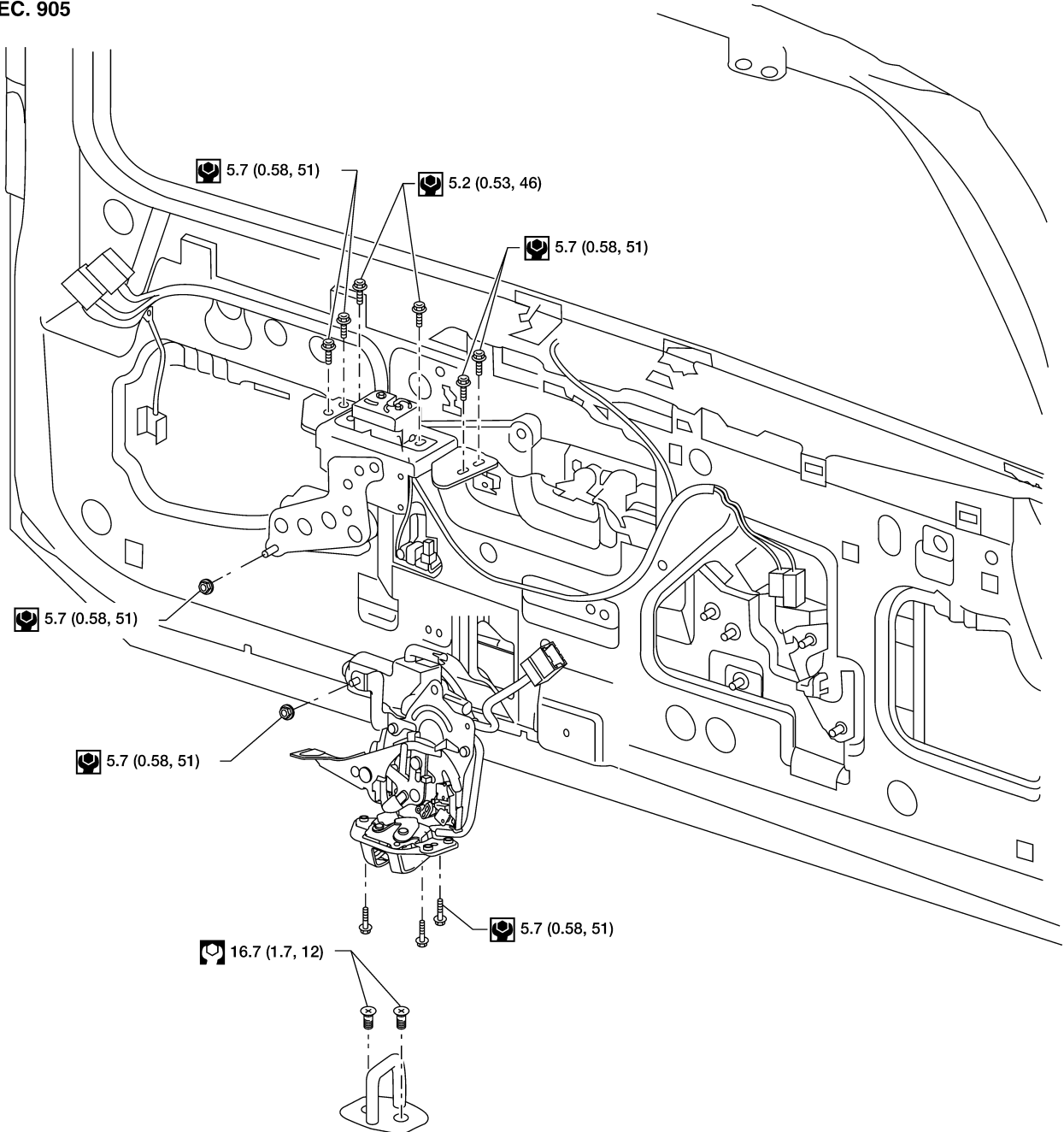

WIHA0894E

1. Remove the lower back door trim panel. Refer to [EI-42, "BACK DOOR TRIM"](#).
2. Remove the weathershields.
3. Disconnect the back door lock electrical connectors.
4. Remove the back door lock assembly.
5. Disconnect the back door glass lock electrical connector.
6. Remove the back door glass lock.

INSTALLATION

Installation is in the reverse order of removal.

IVIS (INFINITI VEHICLE IMMOBILIZER SYSTEM-NATS)

IVIS (INFINITI VEHICLE IMMOBILIZER SYSTEM-NATS)

PF:28591

Component Parts and Harness Connector Location

EIS008RW

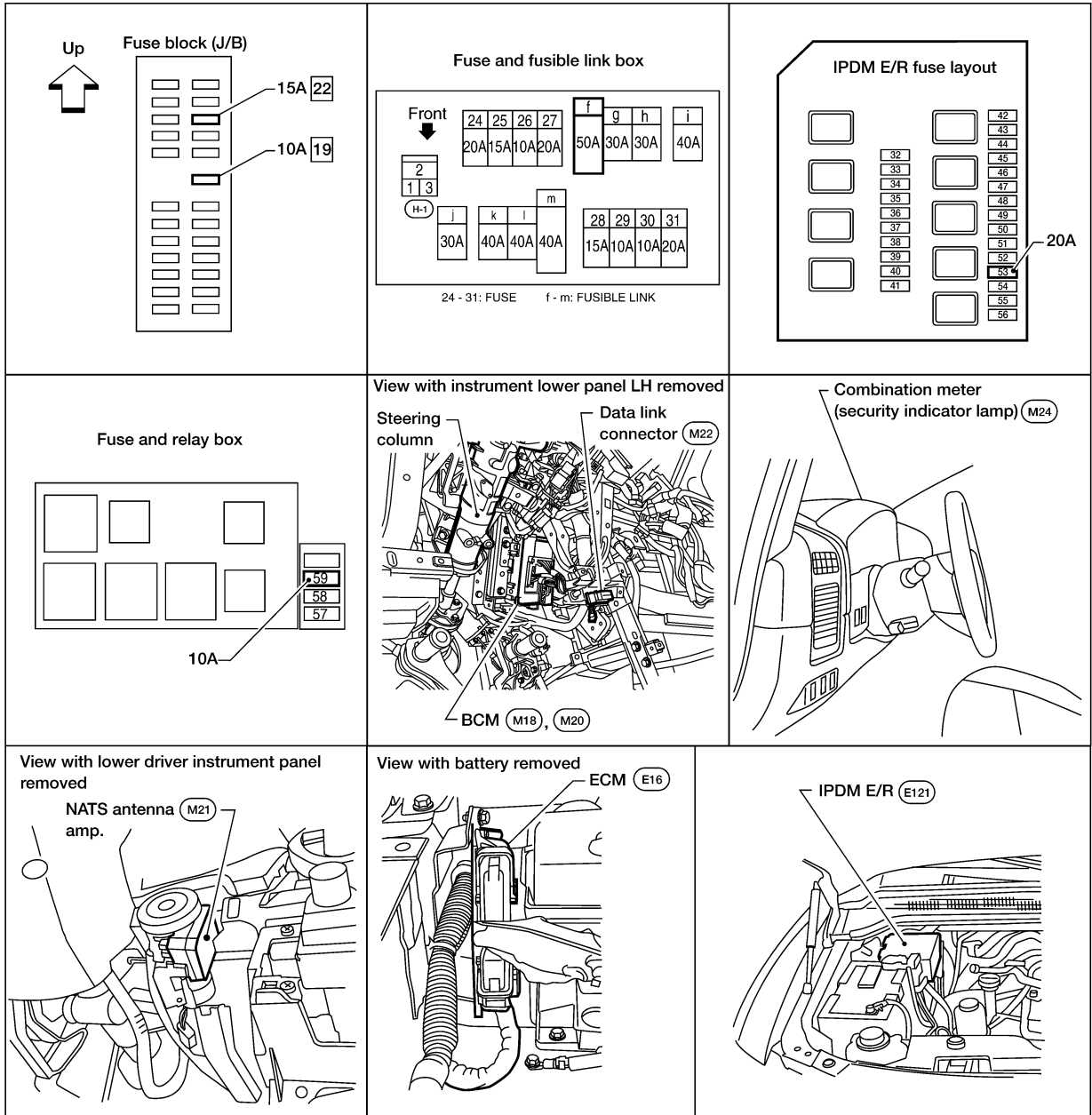

A
B
C
D
E
F
G
H
J
K
L
M

BL

LIA1934E

IVIS (INFINITI VEHICLE IMMOBILIZER SYSTEM-NATS)

EIS008RX

System Description

IVIS (Infinity Vehicle Immobilizer System-NATS) has the following immobilizer functions:

- Since only IVIS (NATS) ignition keys, whose IDs have been registered into the ECM and BCM, allow the engine to run, operation of a stolen vehicle without a IVIS (NATS) registered key is prevented by IVIS (NATS).
IVIS (NATS) will immobilize the engine if someone tries to start it without the registered key of IVIS (NATS).
- All of the originally supplied ignition key IDs have been IVIS (NATS) registered.
If requested by the vehicle owner, a maximum of five key IDs can be registered into the IVIS (NATS) components.
- The security indicator blinks when the ignition switch is in OFF or ACC position. IVIS (NATS) warns outsiders that the vehicle is equipped with the anti-theft system.
- When IVIS (NATS) detects a malfunction, the security indicator lamp lights up while ignition key is in the ON position.
- IVIS (NATS) trouble diagnoses, system initialization and additional registration of other IVIS (NATS) ignition key IDs must be carried out using CONSULT-II hardware and CONSULT-II IVIS (NATS) software.
When IVIS (NATS) initialization has been completed, the ID of the inserted ignition key is automatically IVIS (NATS) registered. Then, if necessary, additional registration of other IVIS (NATS) ignition key IDs can be carried out.
Regarding the procedures of IVIS (NATS) initialization and IVIS (NATS) ignition key ID registration, refer to CONSULT-II Operation Manual NATS-IVIS/NVIS.
- **When servicing a malfunction of the IVIS (NATS) (indicated by lighting up of Security Indicator Lamp) or registering another IVIS (NATS) ignition key ID, it may be necessary to re-register original key identification. Therefore, be sure to receive ALL KEYS from vehicle owner.**

System Composition

EIS008RY

The immobilizer function of the IVIS (NATS) consists of the following:

- NATS ignition key
- NATS antenna amp. located in the ignition key cylinder
- Body control module (BCM)
- Engine control module (ECM)
- Security indicator

NOTE:

The communication between ECM and BCM uses the CAN communication system.

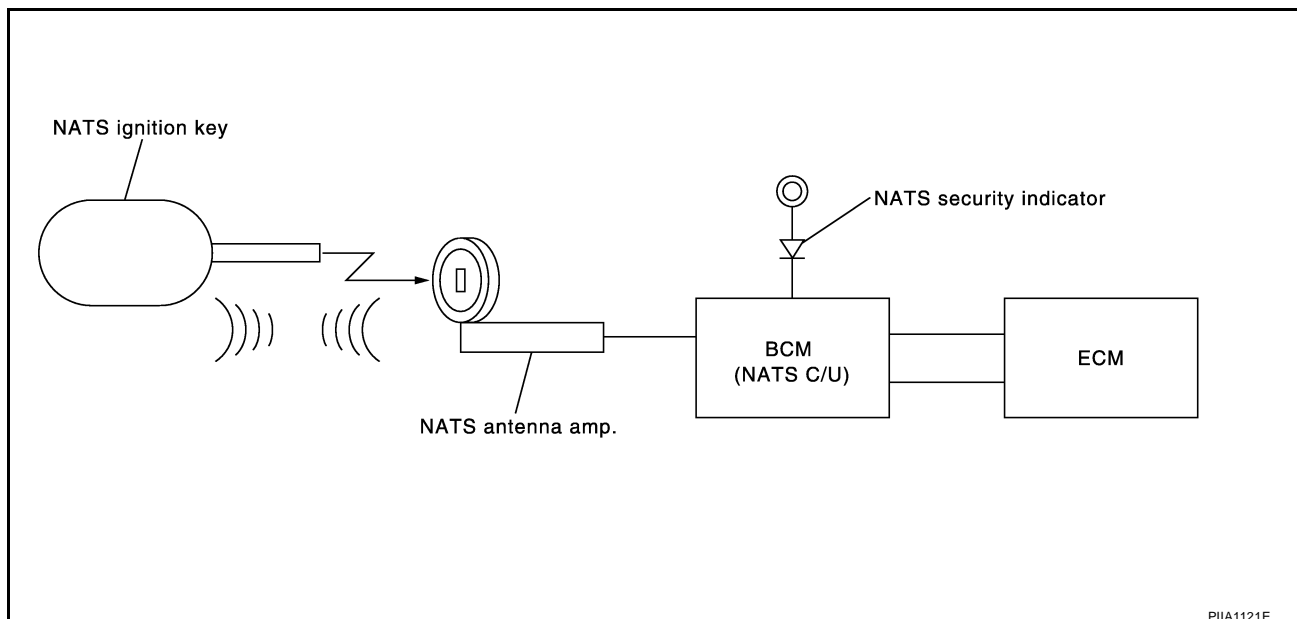

PIA1121E

IVIS (INFINITI VEHICLE IMMOBILIZER SYSTEM-NATS)

EIS008RZ

ECM Re-communicating Function

The following procedure can automatically perform re-communication of ECM and BCM, but only when the ECM has been replaced with a new one which has never been energized on-board.
(In this step, initialization procedure by CONSULT-II is not necessary)

NOTE:

- **When registering new key IDs or replacing the ECM other than brand new, refer to CONSULT-II Operation Manual NATS-IVIS/NVIS.**
 - **If multiple keys are attached to the key holder, separate them before work.**
 - **Distinguish keys with unregistered key ID from those with registered ID.**
1. Install ECM.
 2. Using a registered key (*1), turn ignition switch to ON.
*1: To perform this step, use the key that has been used before performing ECM replacement.
 3. Maintain ignition switch in ON position for at least 5 seconds.
 4. Turn ignition switch to OFF.
 5. Start engine.
If engine can be started, procedure is completed.
If engine cannot be started, refer to CONSULT-II Operation Manual NATS-IVIS/NVIS and initialize control unit.

A

B

C

D

E

F

G

H

BL

J

K

L

M

IVIS (INFINITI VEHICLE IMMOBILIZER SYSTEM-NATS)

EIS00850

Wiring Diagram — NATS —

BL-NATS-01

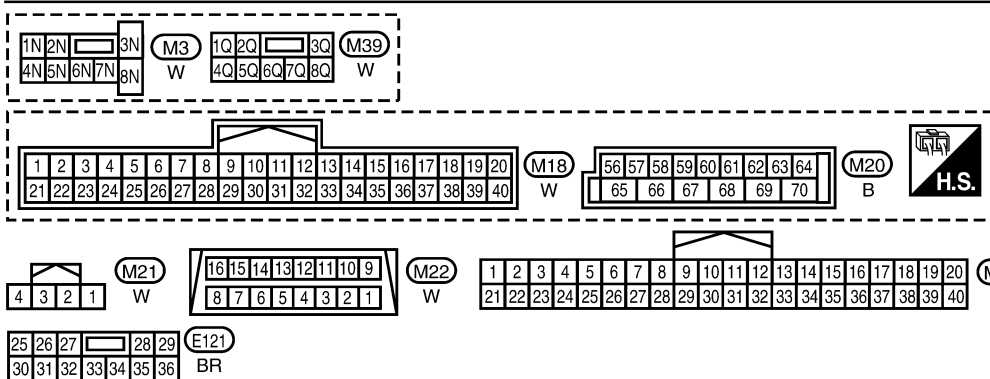
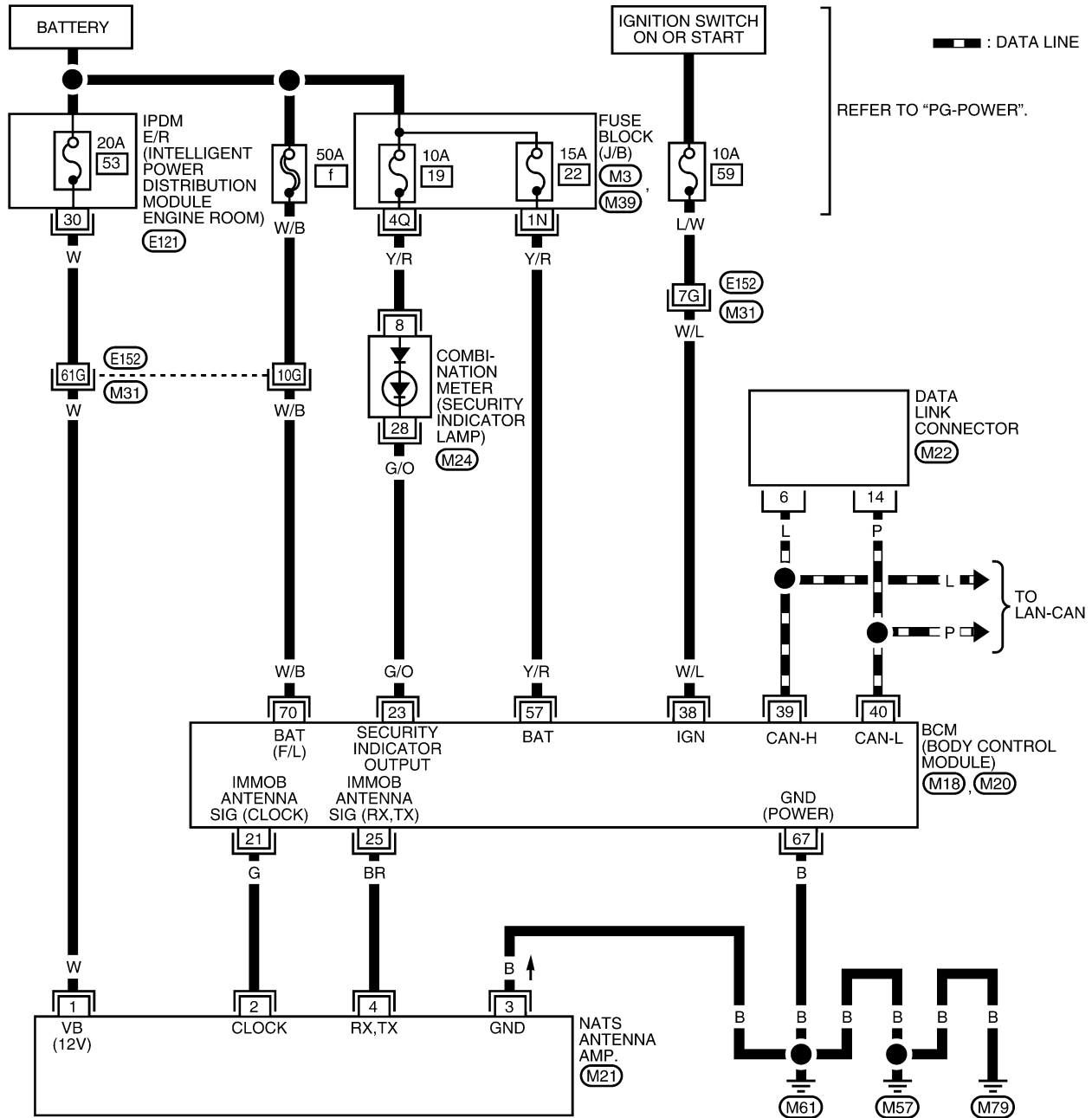

WIWA1318E

IVIS (INFINITI VEHICLE IMMOBILIZER SYSTEM-NATS)

Terminals and Reference Value for BCM

EIS008S1

Terminal	Wire Color	Item	Condition	Voltage (V) (Approx.)
21	G	NATS antenna amp.	Ignition switch (OFF → ON)	Just after turning ignition switch ON: Pointer of tester should move.
23	G/O	Security indicator lamp	Goes OFF → illuminates (Every 2.4 seconds)	Battery voltage → 0
25	BR	NATS antenna amp.	Ignition switch (OFF → ON)	Just after turning ignition switch ON: Pointer of tester should move.
38	W/L	Ignition switch (ON or START)	Ignition switch (ON or START position)	Battery voltage
39	L	CAN-H	—	—
40	P	CAN-L	—	—
57	Y/R	Battery power supply	—	Battery voltage
67	B	Ground	—	0
70	W/B	Battery power supply	—	Battery voltage

CONSULT-II

CONSULT-II INSPECTION PROCEDURE

EIS008S2

CAUTION:

If CONSULT-II is used with no connection of CONSULT-II CONVERTER, malfunctions might be detected in self-diagnosis depending on control unit which carries out CAN communication.

1. Turn ignition switch OFF.
2. Insert IVIS (NATS) program card into CONSULT-II.

Program card : NATS (AEN04A-1) or later

3. Connect CONSULT-II and CONSULT-II CONVERTER to data link connector.

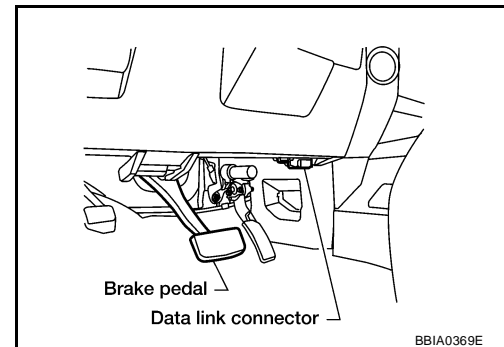

4. Turn ignition switch ON.
5. Touch "START".

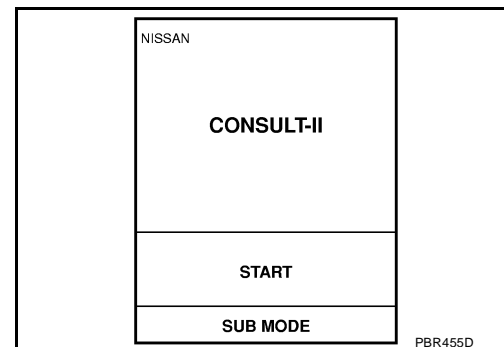

IVIS (INFINITI VEHICLE IMMOBILIZER SYSTEM-NATS)

6. Touch "OTHER".

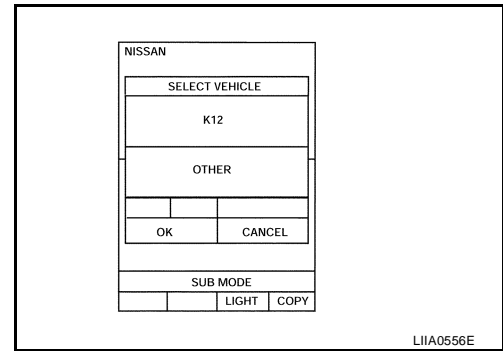

7. Select "NATS V.5.0".
If "NATS V5.0" is not indicated, go to [GI-39, "CONSULT-II Data Link Connector \(DLC\) Circuit"](#).

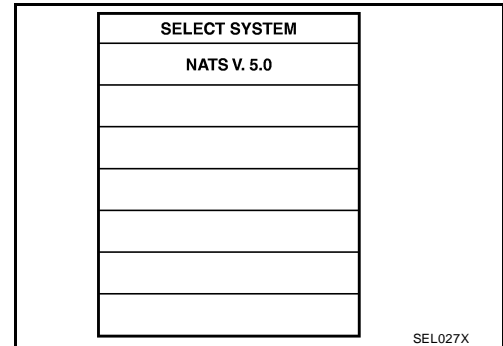

8. Perform each diagnostic test mode according to each service procedure.
For further information, see the CONSULT-II Operation Manual NATS-IVIS/NVIS.

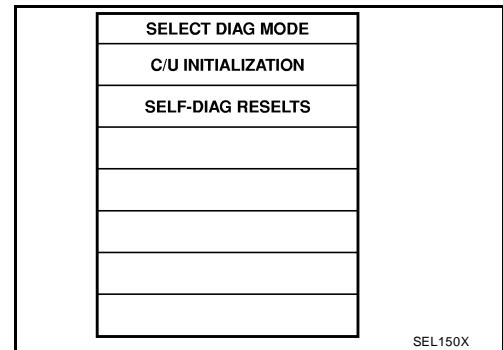

CONSULT-II DIAGNOSTIC TEST MODE FUNCTION

CONSULT-II DIAGNOSTIC TEST MODE	Description
C/U INITIALIZATION	When replacing any of the following components, C/U initialization and re-registration of all NATS ignition keys are necessary. [(NATS ignition key/ BCM/ ECM]
SELF-DIAG RESULTS	Detected items (screen terms) are as shown in the chart. Refer to BL-143, "IVIS (NATS) SELF-DIAGNOSTIC RESULTS ITEM CHART" .

NOTE:

- When any initialization is performed, all IDs previously registered will be erased and all NATS ignition keys must be registered again.
- The engine cannot be started with an unregistered key. In this case, the system will show "DIFFERENCE OF KEY" or "LOCK MODE" as a self-diagnostic result on the CONSULT-II screen.
- In rare case, "CHAIN OF ECM-IMMU" might be stored as a self-diagnostic result during key registration procedure, even if the system is not malfunctioning.

IVIS (INFINITI VEHICLE IMMOBILIZER SYSTEM-NATS)

EIS008S3

Work Flow

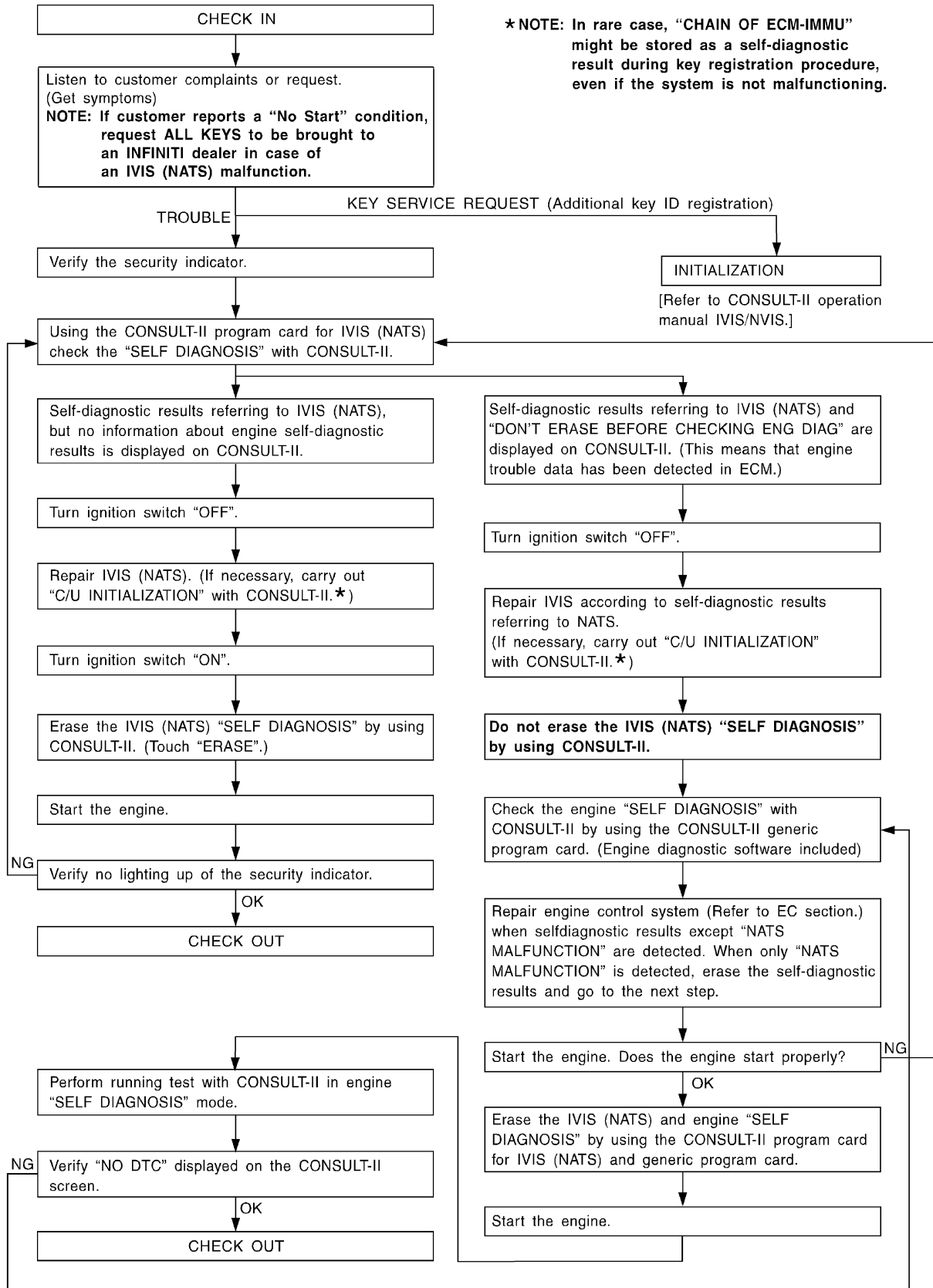

SEL024X

IVIS (INFINITI VEHICLE IMMOBILIZER SYSTEM-NATS)

EIS008S4

Trouble Diagnoses SYMPTOM MATRIX CHART 1

Self-diagnosis related item

Symptom	Displayed "SELF-DIAG RESULTS" on CONSULT-II screen.	Diagnostic Procedure (Reference page)	System (Malfunctioning part or mode)	Reference Part No. Of Illustration On System Diagram
<ul style="list-style-type: none"> ● Security indicator lighting up* ● Engine cannot be started 	CHAIN OF ECM-IMMU [P1612]	PROCEDURE 1 (BL-147)	In rare case, "CHAIN OF ECM-IMMU" might be stored during key registration procedure, even if the system is not malfunctioning.	—
			Open circuit in battery voltage line of BCM circuit	C1
			Open circuit in ignition line of BCM circuit	C2
			Open circuit in ground line of BCM circuit	C3
			Open or short circuit between BCM and ECM communication line	C4
			ECM	B
			BCM	A
	DIFFERENCE OF KEY [P1615]	PROCEDURE 2 (BL-148)	Unregistered key	D
			BCM	A
	CHAIN OF IMMU-KEY [P1614]	PROCEDURE 5 (BL-151)	Malfunction of key ID chip	E5
			Communication line between ANT/ AMP and BCM:	E1
			Open circuit or short circuit of battery voltage line or ground line	E2
			Open circuit in power source line of ANT/ AMP circuit	E3
			Open circuit in ground line of ANT/ AMP circuit	E4
			NATS antenna amp.	E6
			BCM	A
	ID DISCORD, IMM-ECM [P1611]	PROCEDURE 3 (BL-149)	System initialization has not yet been completed.	F
ECM			B	
LOCK MODE [P1610]	PROCEDURE 4 (BL-150)	LOCK MODE	D	
Security indicator lighting up*	DON'T ERASE BEFORE CHECKING ENG DIAG	WORK FLOW (BL-144)	Engine trouble data and IVIS (NATS) trouble data have been detected in ECM	—

*: When IVIS (NATS) detects a malfunction, the security indicator lights up while ignition key is in the "ON" position.

IVIS (INFINITI VEHICLE IMMOBILIZER SYSTEM-NATS)

SYMPTOM MATRIX CHART 2

Non self-diagnosis related item

Symptom	Diagnostic Procedure (Reference page)	System (Malfunctioning part or mode)	Reference Part No. Of Illustration On System Diagram
Security indicator does not light up*.	PROCEDURE 6 (BL-154)	Combination meter (security indicator lamp)	—
		Open circuit between fuse and BCM	—
		BCM	A

*: CONSULT-II self-diagnostic results display screen "no malfunction is detected".

DIAGNOSTIC SYSTEM DIAGRAM

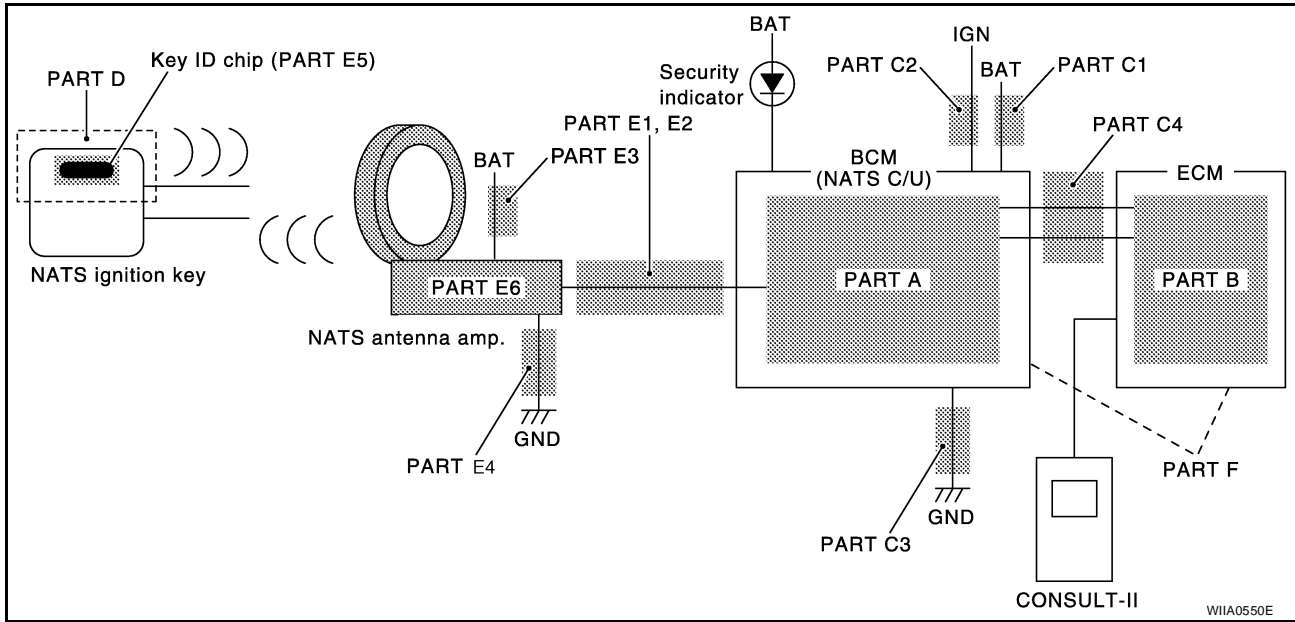

IVIS (INFINITI VEHICLE IMMOBILIZER SYSTEM-NATS)

EIS00855

Diagnostic Procedure 1

Self-diagnostic results:

“CHAIN OF ECM-IMMU” displayed on CONSULT-II screen

First perform the “SELF-DIAG RESULTS” in “BCM” with CONSULT-II, then perform the trouble diagnosis of malfunction system indicated “SELF-DIAG RESULTS” of “BCM”. Refer to [BL-141. "CONSULT-II"](#)

1. CONFIRM SELF-DIAGNOSTIC RESULTS

Confirm SELF-DIAGNOSTIC RESULTS “CHAIN OF ECM-IMMU” displayed on CONSULT-II screen.

NOTE:

In rare case, “CHAIN OF ECM-IMMU” might be stored during key registration procedure, even if the system is not malfunctioning.

Is CONSULT-II screen displayed as above?

YES >> GO TO 2.

NO >> GO TO [BL-145. "SYMPTOM MATRIX CHART 1"](#).

SELF DIAGNOSIS	
DTC RESULTS	TIME
CHAIN OF ECM-IMMU [P1612]	0

PIIA1260E

2. CHECK POWER SUPPLY CIRCUIT FOR BCM

1. Turn ignition switch OFF.
2. Disconnect BCM.
3. Check voltage between BCM connector M20 terminal 70 and ground.

70 - Ground

:Battery voltage

OK or NG

OK >> GO TO 3.

NG >> Check the following:

- 50A fusible link (letter **f**, located in fuse and fusible link box)
- Harness for open or short between fuse and BCM connector. **Ref. Part No. C1**

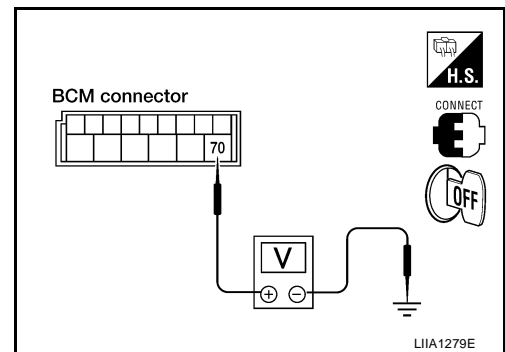

3. CHECK IGN SW. ON SIGNAL

1. Turn ignition switch ON.
2. Check voltage between BCM connector M18 terminal 38 and ground.

38 - Ground

:Battery voltage

OK or NG

OK >> GO TO 4.

NG >> Check the following:

- 10A fuse [No. 59, located in the fuse and relay box]
- Harness for open or short between fuse and BCM connector. **Ref. part No. C2**

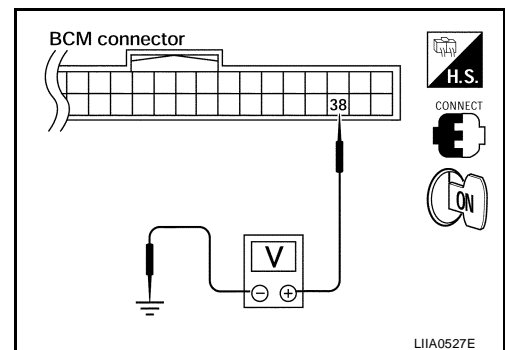

IVIS (INFINITI VEHICLE IMMOBILIZER SYSTEM-NATS)

4. CHECK GROUND CIRCUIT FOR BCM

1. Turn ignition switch OFF.
2. Check continuity between BCM connector M20 terminal 67 and ground.

67 - Ground :Continuity should exist.

OK or NG

- OK >> GO TO 5.
NG >> Repair or replace harness. **Ref. part No. C3**

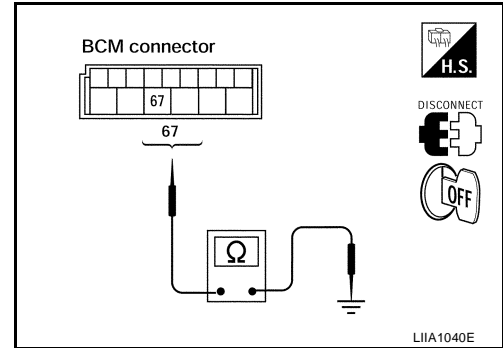

5. REPLACE BCM

1. Replace BCM. **Ref. part No. A**
2. Perform initialization with CONSULT-II.
For initialization, refer to "CONSULT-II Operation Manual NATS-IVIS/NVIS".

Does the engine start?

- YES >> BCM is malfunctioning.
NO >> ECM is malfunctioning.
- Replace ECM. **Ref. part No. B**
 - Perform initialization or re-communicating function.
 - For initialization, refer to "CONSULT-II Operation Manual NATS-IVIS/NVIS".
 - For re-communicating function, refer to [BL-139, "ECM Re-communicating Function"](#).

Diagnostic Procedure 2

EIS008S6

Self-diagnostic results:

"DIFFERENCE OF KEY" displayed on CONSULT-II screen

1. CONFIRM SELF-DIAGNOSTIC RESULTS

Confirm SELF-DIAGNOSTIC RESULTS "DIFFERENCE OF KEY" displayed on CONSULT-II screen.

Is CONSULT-II screen displayed as above?

- YES >> GO TO 2.
NO >> GO TO [BL-145, "SYMPTOM MATRIX CHART 1"](#).

SELF DIAG RESULTS	
DTC RESULTS	TIME
DIFFERENCE OF KEY [P1615]	0

PIA1261E

IVIS (INFINITI VEHICLE IMMOBILIZER SYSTEM-NATS)

2. PERFORM INITIALIZATION WITH CONSULT-II

Perform initialization with CONSULT-II. Re-register all NATS ignition key IDs.

For initialization and registration of NATS ignition key IDs, refer to "CONSULT-II Operation Manual NATS-IVIS/NVIS".

NOTE:

If the initialization is not completed or malfunctions, CONSULT-II shows message on the screen.

Can the system be initialized and can the engine be started with re-registered NATS ignition key?

YES >> Ignition key ID was unregistered. **Ref. part No. D**

NO >> BCM is malfunctioning.

- Replace BCM. **Ref. part No. A**
- Perform initialization with CONSULT-II.
- For initialization, refer to "CONSULT-II Operation Manual NATS-IVIS/NVIS".

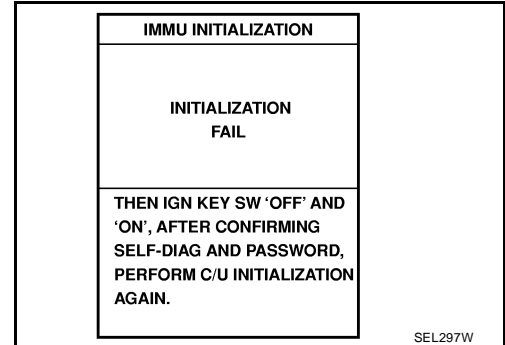

Diagnostic Procedure 3

EIS008S7

Self-diagnostic results:

"ID DISCORD, IMM-ECM" displayed on CONSULT-II screen

1. CONFIRM SELF-DIAGNOSTIC RESULTS

Confirm SELF-DIAGNOSTIC RESULTS "ID DISCORD, IMM-ECM" displayed on CONSULT-II screen.

NOTE:

"ID DISCORD IMM-ECM":

Registered ID of BCM is in discord with that of ECM.

Is CONSULT-II screen displayed as above?

YES >> GO TO 2.

NO >> GO TO [BL-145, "SYMPTOM MATRIX CHART 1"](#).

SELF DIAG RESULTS	
DTC RESULTS	TIME
ID DISCORD, IMM-ECM [P1611]	0

P1IA1262E

2. PERFORM INITIALIZATION WITH CONSULT-II

Perform initialization with CONSULT-II. Re-register all NATS ignition key IDs.

For initialization, refer to "CONSULT-II Operation Manual NATS-IVIS/NVIS".

NOTE:

If the initialization is not completed or malfunctions, CONSULT-II shows message on the screen.

Can the system be initialized?

YES >> ● Start engine. (END)

- (System initialization had not been completed. **Ref. part No. F**)

NO >> ECM is malfunctioning.

- Replace ECM. **Ref. part No. B**
- Perform initialization with CONSULT-II.
For initialization, refer to "CONSULT-II Operation Manual NATS-IVIS/NVIS".

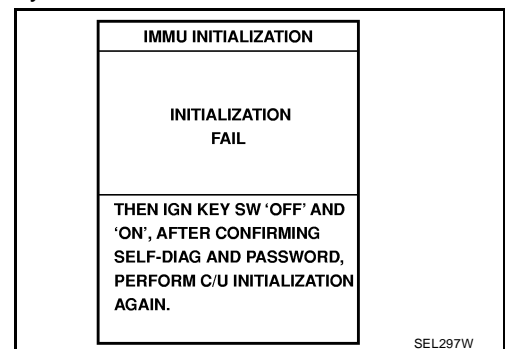

IVIS (INFINITI VEHICLE IMMOBILIZER SYSTEM-NATS)

EIS008S8

Diagnostic Procedure 4

Self-diagnostic results:

“LOCK MODE” displayed on CONSULT-II screen

1. CONFIRM SELF-DIAGNOSTIC RESULTS

Confirm SELF-DIAGNOSTIC RESULTS “LOCK MODE” is displayed on CONSULT-II screen.

Is CONSULT-II screen displayed as above?

YES >> GO TO 2.

NO >> GO TO [BL-145, "SYMPTOM MATRIX CHART 1"](#).

SELF DIAG RESULTS	
DTC RESULTS	TIME
LOCK MODE [P1610]	0

PIA1264E

2. ESCAPE FROM LOCK MODE

1. Turn ignition switch OFF.
2. Turn ignition switch ON with registered key. (Do not start engine.) Wait 5 seconds.
3. Return the key to OFF position. Wait 5 seconds.
4. Repeat steps 2 and 3 twice (total of three cycles).
5. Start the engine.

Does engine start?

YES >> System is OK (Now system is escaped from “LOCK MODE”). Clear all codes.

NO >> GO TO 3.

3. PERFORM INITIALIZATION WITH CONSULT-II

Perform initialization with CONSULT-II.

For initialization, refer to “CONSULT-II Operation Manual NATS-IVIS/NVIS”.

NOTE:

If the initialization is not completed or malfunctions, CONSULT-II shows the message on the screen.

Can the system be initialized?

YES >> System is OK.

NO >> GO TO 4.

IMMU INITIALIZATION
INITIALIZATION FAIL
THEN IGN KEY SW 'OFF' AND 'ON', AFTER CONFIRMING SELF-DIAG AND PASSWORD, PERFORM C/U INITIALIZATION AGAIN.

SEL297W

IVIS (INFINITI VEHICLE IMMOBILIZER SYSTEM-NATS)

4. PERFORM INITIALIZATION WITH CONSULT-II AGAIN

1. Replace BCM.
2. Perform initialization with CONSULT-II.
For initialization, refer to "CONSULT-II Operation Manual NATS-IVIS/NVIS".

NOTE:

If the initialization is not completed or malfunctions, CONSULT-II shows the message on the screen.

Can the system be initialized?

- YES >> System is OK. BCM is malfunctioning. **Ref. part No. A**
NO >> ECM is malfunctioning.

- Replace ECM. **Ref. part No. B**
- Perform initialization with CONSULT-II.
For initialization, refer to "CONSULT-II Operation Manual NATS-IVIS/NVIS".

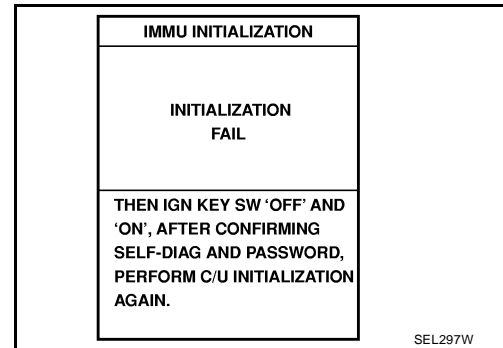

Diagnostic Procedure 5

E/S008S9

Self-diagnostic results:

"CHAIN OF IMMU-KEY" displayed on CONSULT-II screen

1. CONFIRM SELF-DIAGNOSTIC RESULTS

Confirm SELF-DIAGNOSTIC RESULTS "CHAIN OF IMMU-KEY" displayed on CONSULT-II screen.

Is CONSULT-II screen displayed as above?

- YES >> GO TO 2.
NO >> GO TO [BL-145, "SYMPTOM MATRIX CHART 1"](#).

The screenshot shows a CONSULT-II screen with the following table:

SELF DIAGNOSIS	
DTC RESULTS	TIME
CHAIN OF IMMU-KEY [P1614]	0

PIA1263E

2. CHECK NATS ANTENNA AMP. INSTALLATION

Check NATS antenna amp. installation. Refer to [BL-155, "How to Replace NATS Antenna Amp."](#).

OK or NG

- OK >> GO TO 3.
NG >> Reinstall NATS antenna amp. correctly.

3. CHECK IVIS (NATS) IGNITION KEY ID CHIP

Start engine with another registered NATS ignition key.

Does the engine start?

- YES >> Ignition key ID chip is malfunctioning.
- Replace the ignition key. **Ref. part No. E5**
 - Perform initialization with CONSULT-II.
For initialization, refer to "CONSULT-II Operation Manual NATS-IVIS/NVIS".
- NO >> GO TO 4.

IVIS (INFINITI VEHICLE IMMOBILIZER SYSTEM-NATS)

4. CHECK POWER SUPPLY FOR NATS ANTENNA AMP.

1. Turn ignition switch ON.
2. Check voltage between NATS antenna amp. connector M21 terminal 1 and ground.

1 - Ground :Battery voltage

OK or NG

- OK >> GO TO 5.
 NG >> Repair or replace fuse or harness. **Ref. part No. E3**

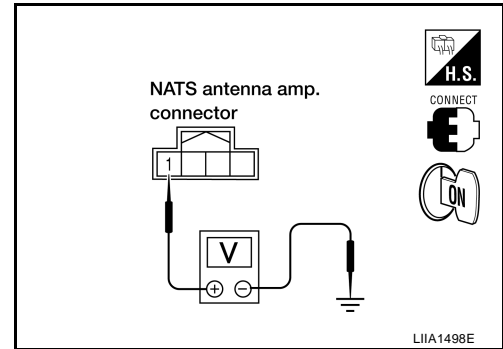

5. CHECK NATS ANTENNA AMP. SIGNAL LINE- 1

Check voltage between NATS antenna amp. connector M21 terminal 2 and ground with analog tester.

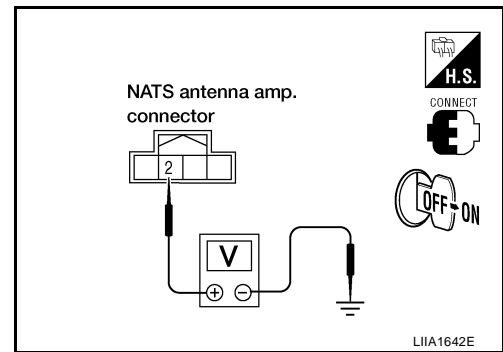

Connector terminals (wire colors)		Position of ignition key cylinder	Voltage (V) (Approx.)
(+)	(-)		
2	Ground	Before inserting ignition key	Battery voltage
		After inserting ignition key	Pointer of tester should move for approx. 30 seconds, then return to battery voltage
		Just after turning ignition switch ON	Pointer of tester should move for approx. 1 second, then return to battery voltage

OK or NG

- OK >> GO TO 6.
 NG >> ● Repair or replace harness.

NOTE:

If harness is OK, replace BCM, perform initialization with CONSULT-II. For initialization, refer to "CONSULT-II Operation Manual NATS-IVIS/NVIS".

IVIS (INFINITI VEHICLE IMMOBILIZER SYSTEM-NATS)

6. CHECK NATS ANTENNA AMP. SIGNAL LINE- 2

Check voltage between NATS antenna amp. connector M21 terminal 4 and ground with analog tester.

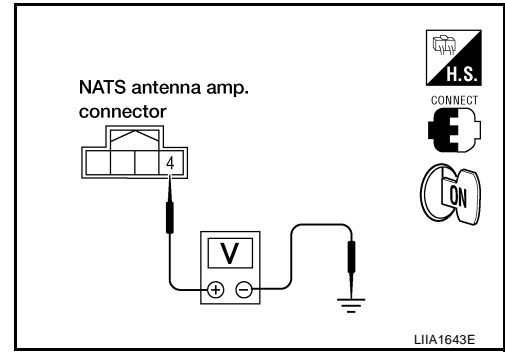

Connector terminals (wire colors)		Position of ignition key cylinder	Voltage (V) (Approx.)
(+)	(-)		
4	Ground	Before inserting ignition key	Battery voltage
		After inserting ignition key	Pointer of tester should move for approx. 30 seconds, then return to battery voltage
		Just after turning ignition switch ON	Pointer of tester should move for approx. 1 second, then return to battery voltage

OK or NG

OK >> GO TO 7.

NG >> ● Repair or replace harness.

NOTE:

If harness is OK, replace BCM, perform initialization with CONSULT-II. For initialization, refer to "CONSULT-II Operation Manual NATS-IVIS/NVIS".

7. CHECK NATS ANTENNA AMP. GROUND LINE CIRCUIT

1. Turn ignition switch OFF.
2. Disconnect NATS antenna amp. connector.
3. Check continuity between NATS antenna amp. connector M21 terminal 3 and ground.

3 - Ground :Continuity should exist.

OK or NG

OK >> NATS antenna amp. is malfunctioning. **Ref. part No. E6**

NG >> ● Repair or replace harness.

NOTE:

If harness is OK, replace BCM, perform initialization with CONSULT-II. For initialization, refer to "CONSULT-II Operation Manual NATS-IVIS/NVIS".

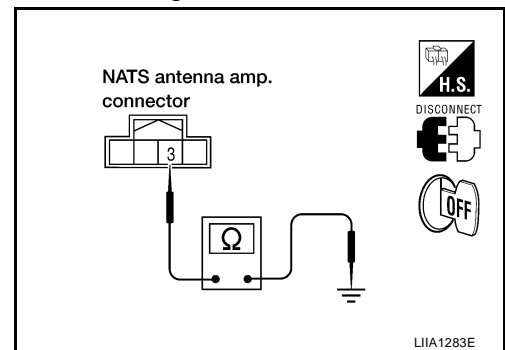

IVIS (INFINITI VEHICLE IMMOBILIZER SYSTEM-NATS)

EIS008SA

Diagnostic Procedure 6

“SECURITY INDICATOR LAMP DOES NOT LIGHT UP”

1. CHECK FUSE

Check 10A fuse [No.19, located in the fuse block (J/B)]

OK or NG

OK >> GO TO 2.

NG >> If fuse is blown, be sure to eliminate cause of malfunction before installing new fuse.

2. CHECK SECURITY INDICATOR LAMP

1. Start engine and turn ignition switch OFF.
2. Check the security indicator lamp lights up.

Security indicator lamp should light up.

OK or NG

OK >> Inspection End.

NG >> GO TO 3.

3. CHECK SECURITY INDICATOR LAMP POWER SUPPLY CIRCUIT

1. Disconnect security indicator lamp.
2. Check voltage between security indicator lamp connector M24 terminal 8 and ground.

8 - Ground

:Battery voltage

OK or NG

OK >> GO TO 4.

NG >> Repair or replace harness.

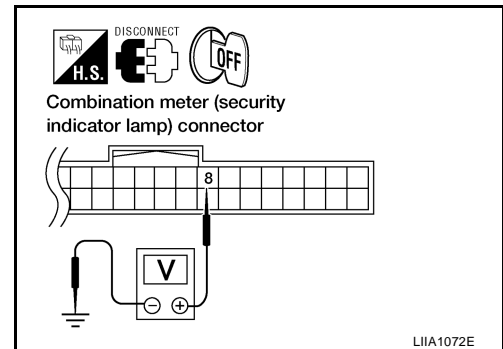

4. CHECK BCM (NATS CONTROL UNIT) FUNCTION

1. Connect security indicator lamp.
2. Disconnect BCM.
3. Check voltage between BCM connector M18 terminal 23 and ground.

23 - Ground

:Battery voltage

OK or NG

OK >> BCM is malfunctioning.

- Replace BCM. **Ref. part No. A**
- Perform initialization with CONSULT-II.
- For initialization, refer to “CONSULT-II Operation Manual NATS-IVIS/NVIS”.

NG >> Check the following:

- Harness for open or short between security indicator lamp and BCM (NATS control unit).
- Indicator lamp condition

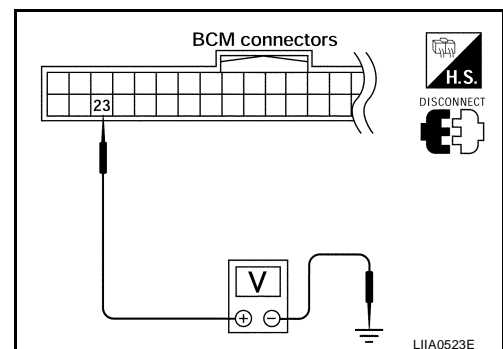

IVIS (INFINITI VEHICLE IMMOBILIZER SYSTEM-NATS)

How to Replace NATS Antenna Amp.

EIS008SB

NOTE:

- If NATS antenna amp. is not installed correctly, IVIS (NATS) system will not operate properly and SELF-DIAG RESULTS on CONSULT-II screen will show "LOCK MODE" or "CHAIN OF IMMU-KEY".
- Initialization is not necessary when only NATS antenna amp. is replaced with a new one.

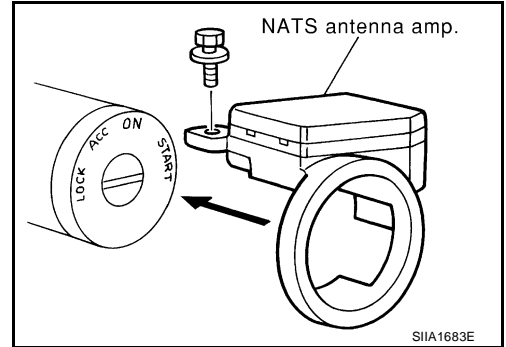

A
B
C
D
E
F
G
H
BL
J
K
L
M

HOMELINK UNIVERSAL TRANSCEIVER

PF9:96401

EIS008SC

HOMELINK UNIVERSAL TRANSCEIVER

Wiring Diagram — TRNSCV —

BL-TRNSCV-01

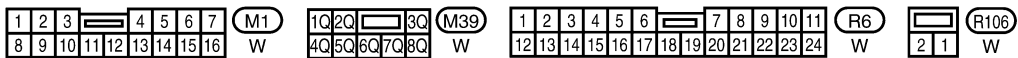
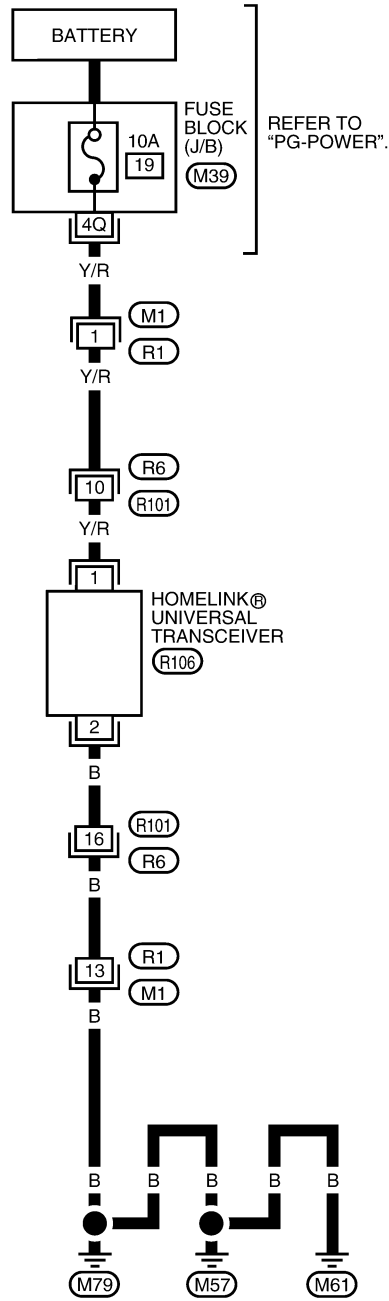

WIWA0759E

HOMELINK UNIVERSAL TRANSCEIVER

EIS008SD

Trouble Diagnoses DIAGNOSTIC PROCEDURE

SYMPTOM: Transmitter does not activate receiver.

Before conducting the procedure given below, make sure that system receiver (garage door opener, etc.) operates with original, hand-held transmitter. If NG, receiver or hand-held transmitter is malfunctioning, not vehicle related.

1. ILLUMINATE CHECK

- Turn ignition switch OFF.
- Does amber light (LED) of transmitter illuminate when any button is pressed?

YES or NO

YES >> GO TO 2.

NO >> GO TO 3.

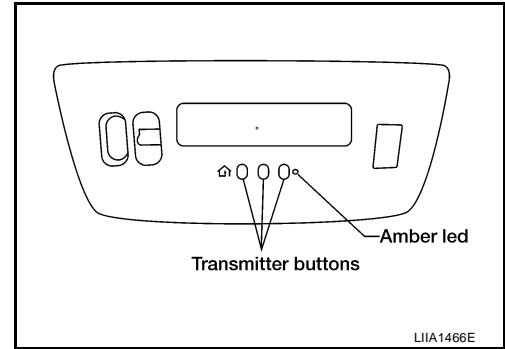

2. TRANSMITTER CHECK

Check transmitter with Tool.*

*For details, refer to Technical Service Bulletin.

OK or NG

OK >> Receiver or hand-held transmitter malfunction, not vehicle related.

NG >> Replace transmitter.

3. POWER SUPPLY CHECK

1. Disconnect transmitter.
2. Check voltage between Homelink® universal transceiver connector R106 terminal 1 and ground.

1 - Ground : **Battery voltage**

OK or NG

OK >> GO TO 4.

NG >> Repair or replace fuse or harness.

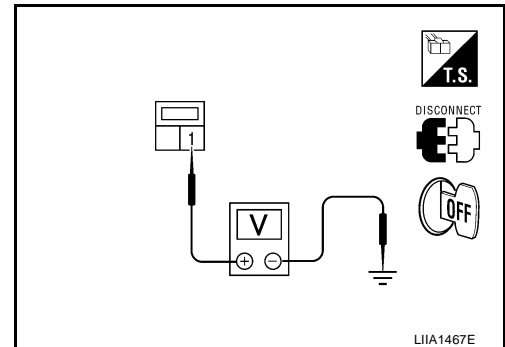

HOMELINK UNIVERSAL TRANSCEIVER

4. GROUND CIRCUIT CHECK

Check continuity between Homelink® universal transceiver connector R106 terminal 2 and body ground.

2 - Ground

: Continuity should exist.

OK or NG

- OK >> Replace compass and thermometer assembly.
- NG >> Repair or replace harness.

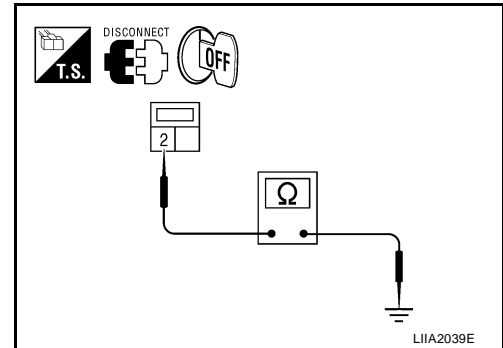

CAB AND REAR BODY

CAB AND REAR BODY

PFP:93020

Body Mounting

EIS008SE

When removing, be sure to replace bolts and nuts (sealant applied bolts or self-lock nuts are used for all mounting).

SEC. 930

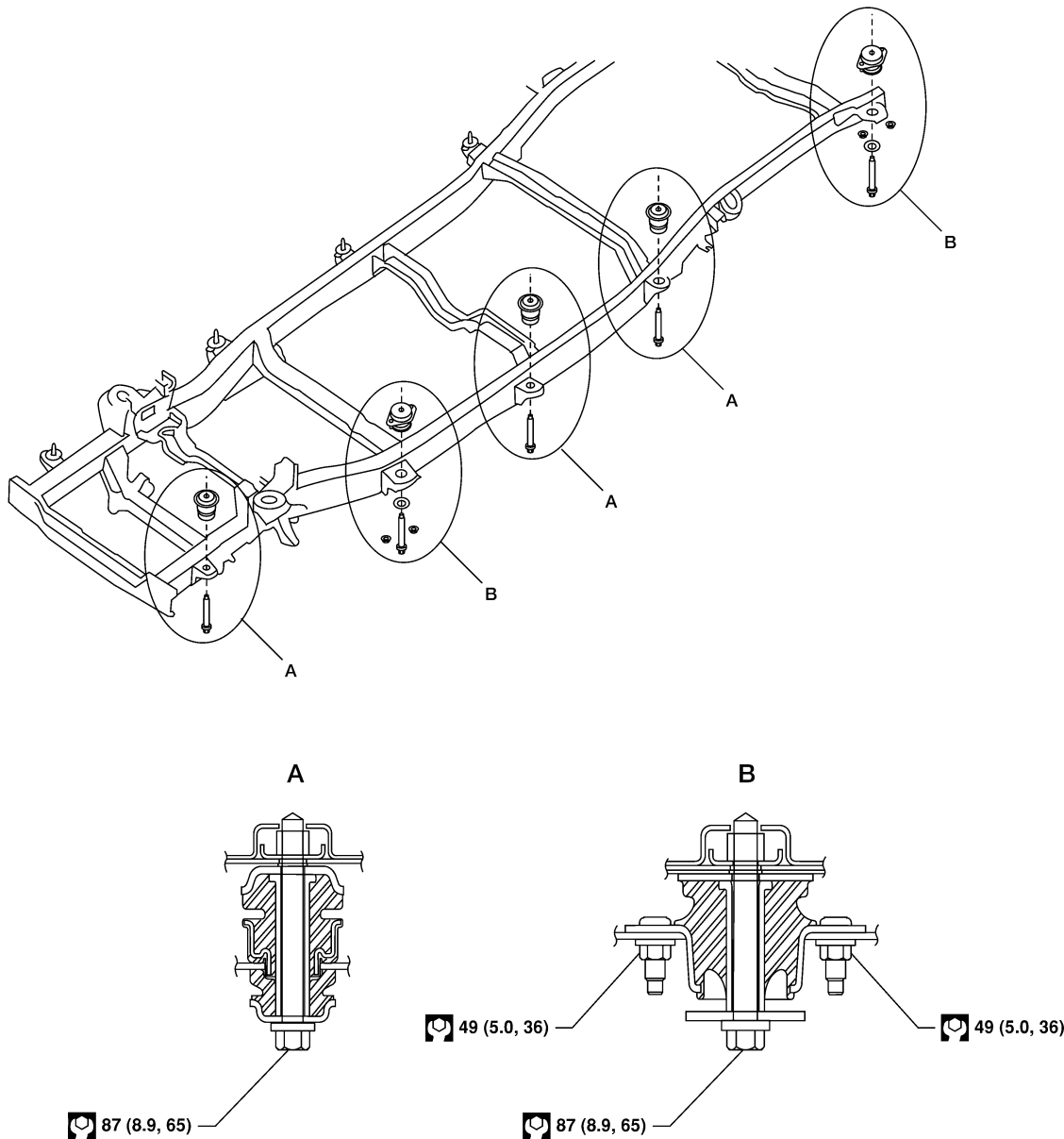

 N-m (kg-m, ft-lb)

LIIA1564E

BODY REPAIR

PF:60100

BODY REPAIR

Body Exterior Paint Color

EIS008SF

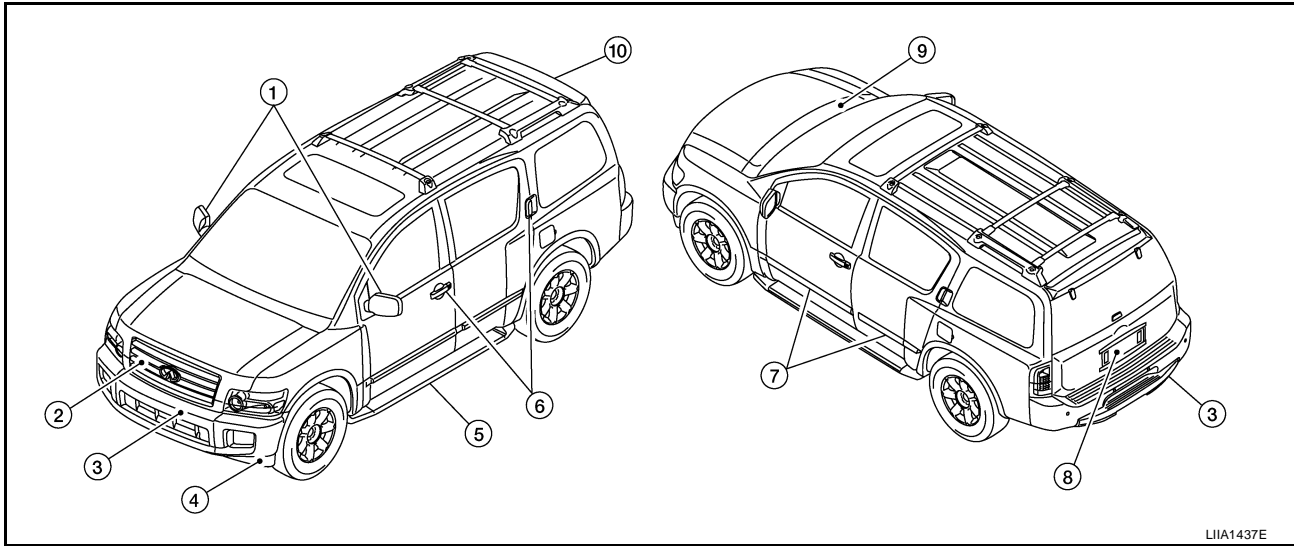

LIA1437E

Component			Color code	B18	EY2	G10	J20	K11	K12	Q11
			Description	Cobalt Blue	Kashmir	Liquid Onyx	Jade	Silver Graphite	Silver Indulgence	Tuscan Pearl
			Clear coat	t	t	t	t	t	t	t
1	Outside mirror	Body	Chromium plate	Cr2P	Cr2P	Cr2P	Cr2P	Cr2P	Cr2P	Cr2P
		Base	Black	KH3	KH3	KH3	KH3	KH3	KH3	KH3
2	Radiator grille	Center and emblem	Chromium plate	Cr2P	Cr2P	Cr2P	Cr2P	Cr2P	Cr2P	Cr2P
3	Bumpers	Fascias	Body color	B18	EY2	G10	J20	K11	K12	Q11
4	Valance		Black	KH3	KH3	KH3	KH3	KH3	KH3	KH3
5	Running Boards	Body	Body color	B18	EY2	G10	J20	K11	K12	Q11
		Step pad	Black	KH3	KH3	KH3	KH3	KH3	KH3	KH3
6	Outside handles		Chromium plate	Cr2P	Cr2P	Cr2P	Cr2P	Cr2P	Cr2P	Cr2P
7	Side Guard Molding	Base	Body color	B18	EY2	G10	J20	K11	BK12	BQ10
		Top Trim	Chromium plate	Cr2P	Cr2P	Cr2P	Cr2P	Cr2P	Cr2P	Cr2P
8	License plate finisher	Base	Body color	B18	EY2	G10	J20	K11	K12	Q11
		Top and bottom trim	Chromium plate	Cr2P	Cr2P	Cr2P	Cr2P	Cr2P	Cr2P	Cr2P
9	Cowl top cover		Body color	B18	EY2	G10	J20	K11	K12	Q11
10	Rear spoiler		Body color	B18	EY2	G10	J20	K11	K12	Q11

M: Metallic; 2S: 2-Coat Solid, 2P: 2-Coat Pearl; 3P: 3-Coat Pearl; t: New Cross Linking Clear Coat



BODY REPAIR

Body Component Parts UNDERBODY COMPONENT PARTS

EIS0085G

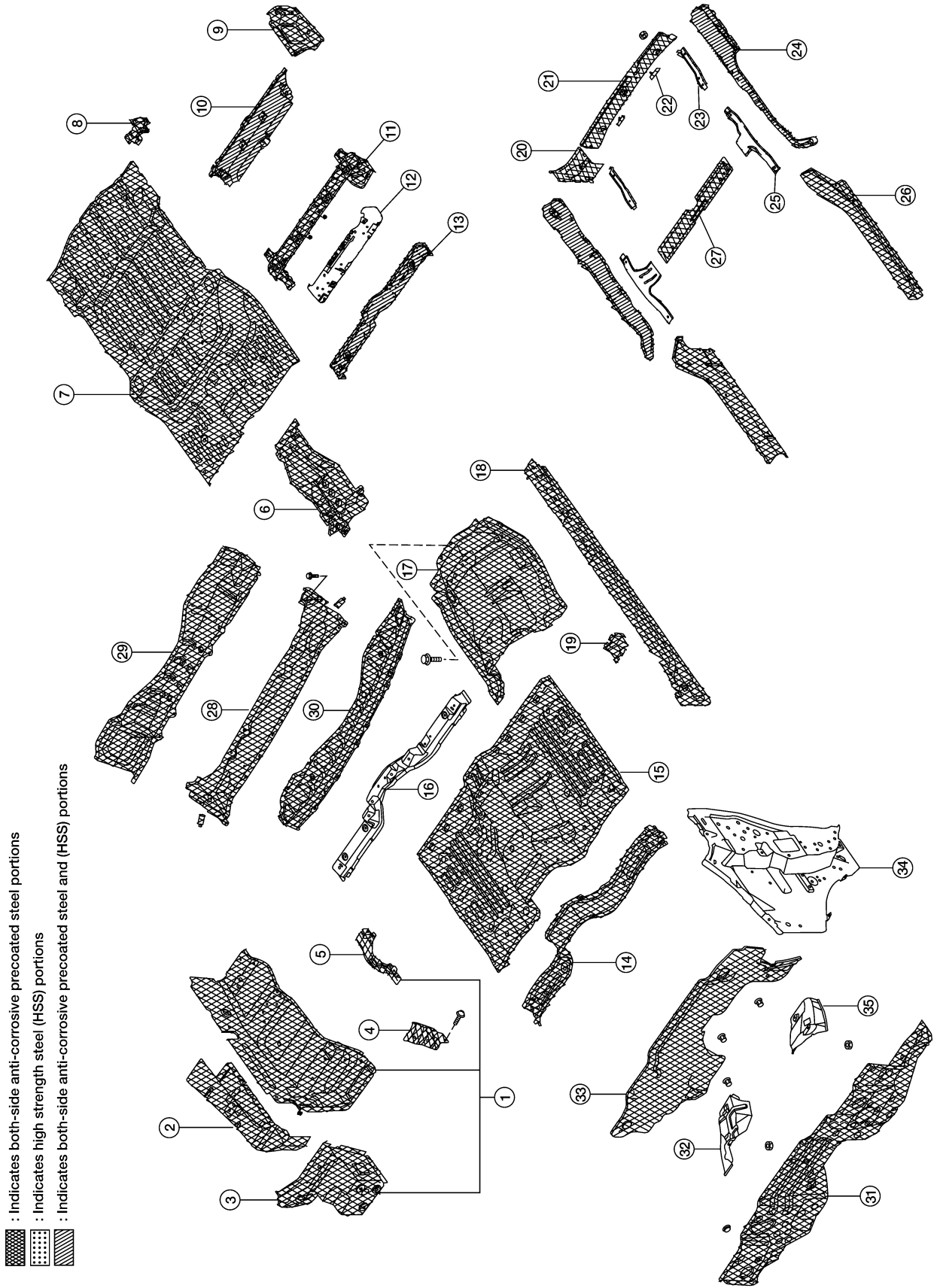
A
B
C
D
E
F
G
H
BL
J
K
L
M



-  : Indicates both-side anti-corrosive pre-coated steel portions
-  : Indicates high strength steel (HSS) portions
-  : Indicates both-side anti-corrosive pre-coated steel and (HSS) portions

LIA0908E



BODY REPAIR

1. Hoodledge assembly (RH, LH)
2. Hoodledge reinforcement (RH, LH)
3. Body mounting bracket (RH, LH)
4. Hoodledge front brace (RH), Battery mounting bracket (LH)
5. Harness connector bracket
6. Rear floor reinforcement
7. Rear floor
8. Rear floor reinforcement
9. Rear floor side (RH, LH)
10. Crossmember
11. Second seat rear crossmember
12. Second seat front crossmember
13. Rear front seat crossmember
14. Second Body crossmember
15. Front floor
16. Front seat front crossmember
17. Front floor reinforcement
18. Outer sill (RH, LH)
19. Second crossmember extension
20. Rear crossmember end
21. Rear lower crossmember end
22. Rear crossmember end (RH, LH)
23. Rear side member rear reinforcement (RH, LH)
24. Rear side member (RH, LH)
25. Rear side member reinforcement (RH, LH)
26. Inner sill extension (RH, LH)
27. Rear crossmember
28. Upper dash top
29. Upper dash bottom
30. Cowl top
31. Lower dash
32. Lower dash insulator (RH)
33. Lower dash reinforcement
34. Side dash (RH, LH)
35. Lower dash insulator

BODY REPAIR

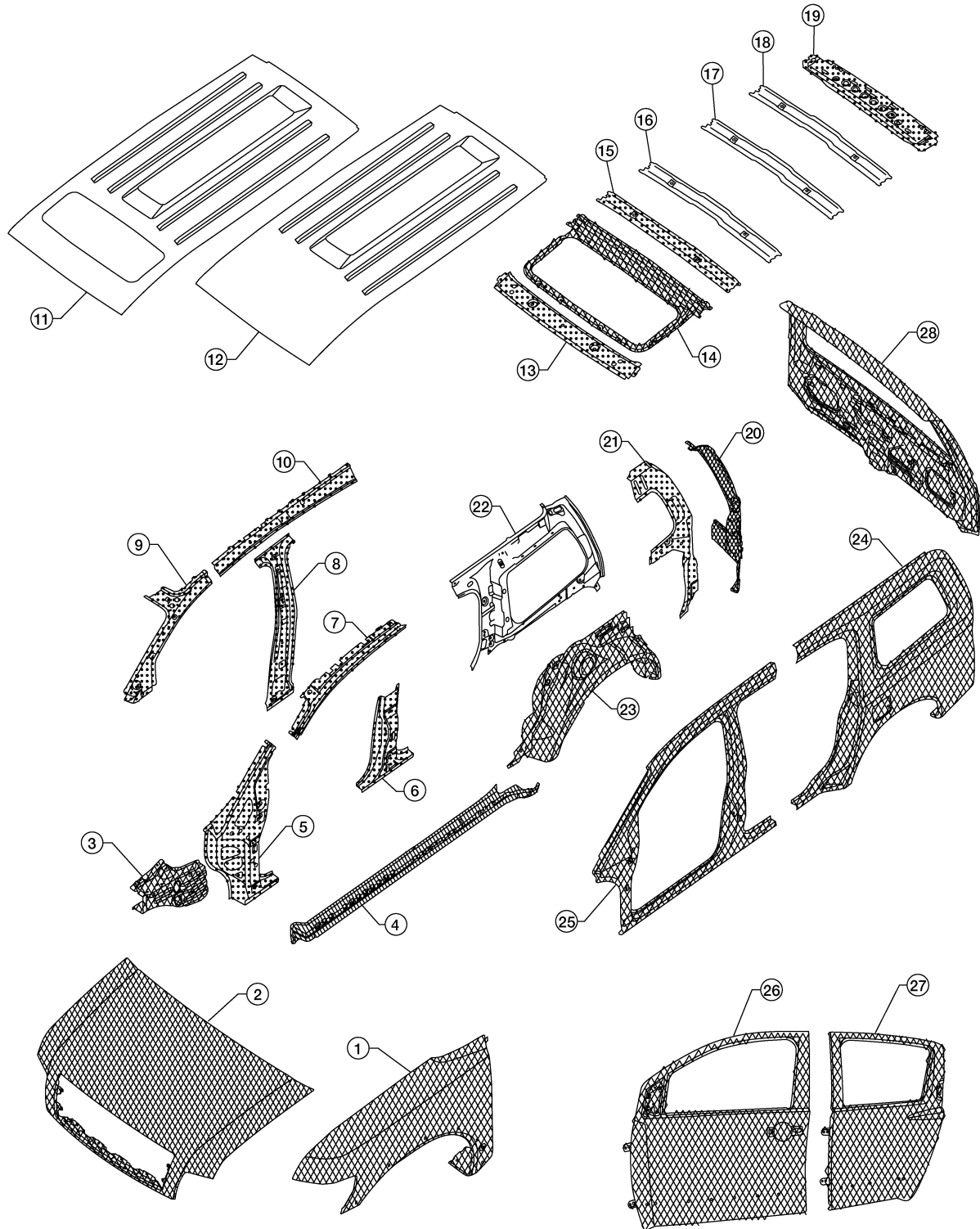
BODY COMPONENT PARTS



-  : Indicates both-side anti-corrosive precoated steel portions
-  : Indicates high strength steel (HSS) portions
-  : Indicates both-side anti-corrosive precoated steel and (HSS) portions

LIIA1438E

BODY REPAIR

1. Front fender (RH, LH)
2. Hood assembly
3. Rear hoodledge reinforcement (RH, LH)
4. Outer sill reinforcement (RH, LH)
5. Front pillar hinge brace (RH, LH)
6. Center pillar hinge brace
7. Outer front pillar reinforcement (RH, LH)
8. Center inner pillar (RH, LH)
9. Front inner pillar upper (RH, LH)
10. Inner roof side rail (RH, LH)
11. Roof with sunroof opening
12. Roof
13. Front roof rail
14. Sunroof reinforcement
15. Roof 1st bow
16. Roof 2nd bow
17. Roof 3rd bow
18. Roof 4th bow
19. Rear roof rail
20. Main back pillar (RH, LH)
21. Back pillar reinforcement (RH, LH)
22. Rear inner side panel (RH, LH)
23. Rear wheel housing (RH, LH)
24. Rear body side outer (RH, LH)
25. Front body side outer (RH, LH)
26. Front door assembly (RH, LH)
27. Rear door assembly (RH, LH)
28. Lift gate assembly

BODY REPAIR

EIS008SH

Corrosion Protection

DESCRIPTION

To provide improved corrosion prevention, the following anti-corrosive measures have been implemented in NISSAN production plants. When repairing or replacing body panels, it is necessary to use the same anti-corrosive measures.

ANTI-CORROSIVE PRECOATED STEEL (GALVANNEALED STEEL)

To improve repairability and corrosion resistance, a new type of anti-corrosive precoated steel sheet has been adopted replacing conventional zinc-coated steel sheet.

Galvannealed steel is electroplated and heated to form Zinc-iron alloy, which provides excellent and long term corrosion resistance with cationic electrode position primer.

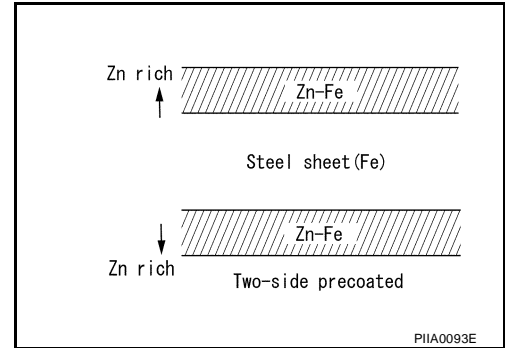

Nissan Genuine Service Parts are fabricated from galvannealed steel. Therefore, it is recommended that GENUINE NISSAN PARTS or equivalent be used for panel replacement to maintain the anti-corrosive performance built into the vehicle at the factory.

PHOSPHATE COATING TREATMENT AND CATIONIC ELECTRODEPOSITION PRIMER

A phosphate coating treatment and a cationic electrode position primer, which provide excellent corrosion protection, are employed on all body components.

CAUTION:

Confine paint removal during welding operations to an absolute minimum.

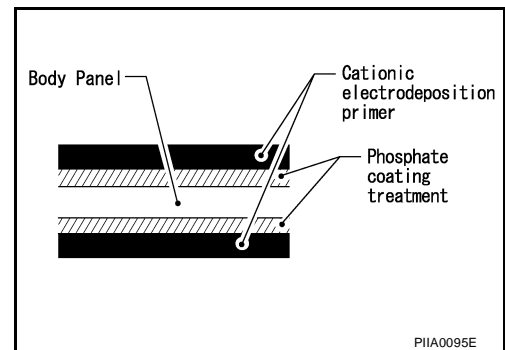



Nissan Genuine Service Parts are also treated in the same manner. Therefore, it is recommended that GENUINE NISSAN PARTS or equivalent be used for panel replacement to maintain anti-corrosive performance built into the vehicle at the factory.

BODY REPAIR

ANTI-CORROSIVE WAX

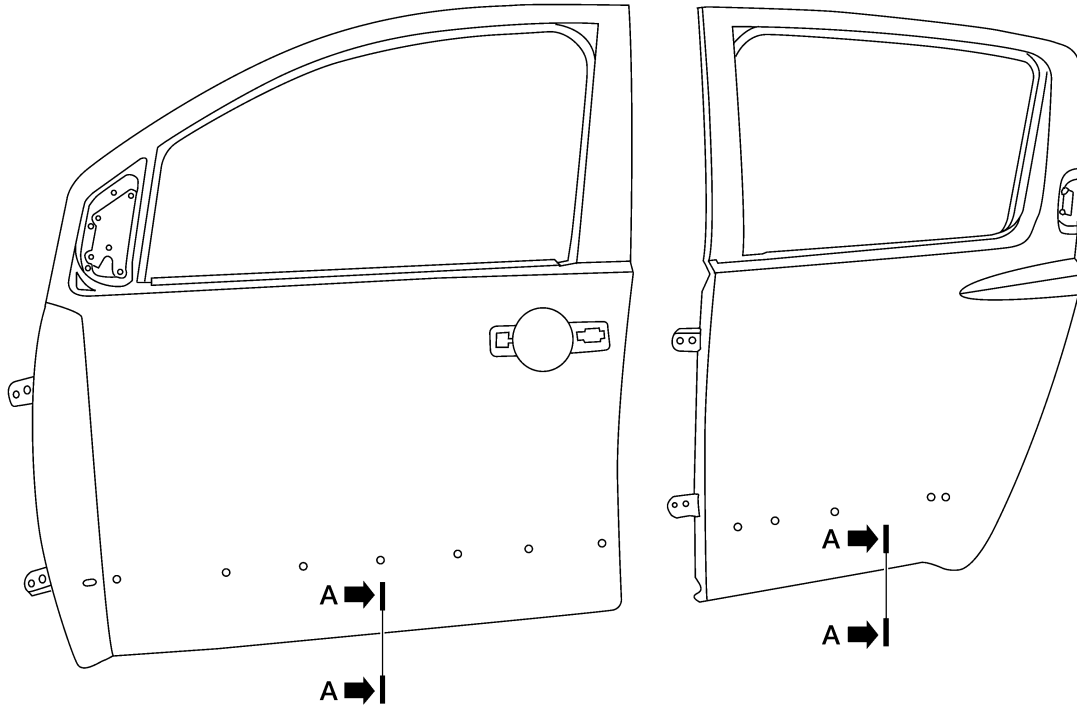
To improve corrosion resistance, anti-corrosive wax is applied inside the body sill and inside other closed sections. Accordingly, when replacing these parts, be sure to apply anti-corrosive wax to the appropriate areas of the new parts. Select an excellent anti-corrosive wax which will penetrate after application and has a long shelf life.



-  : Indicates outside body sealant
-  : Indicates anti-corrosive wax coated portions

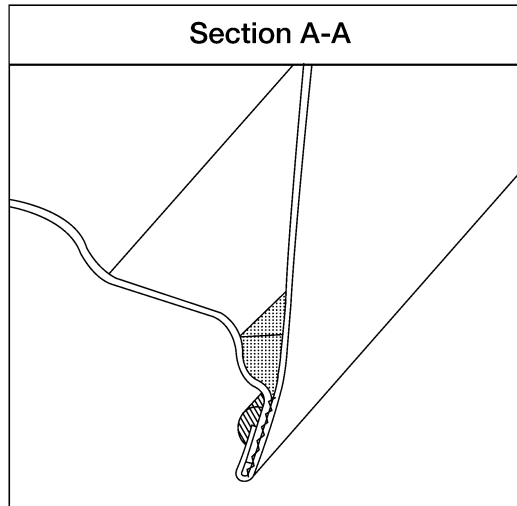

LIA0905E

BODY REPAIR

UNDERCOATING

The underside of the floor and wheelhouse are undercoated to prevent rust, vibration, noise and stone chipping. Therefore, when such a panel is replaced or repaired, apply undercoating to that part. Use an undercoating which is rust preventive, soundproof, vibration-proof, shock-resistant, adhesive, and durable.

Precautions in undercoating

1. Do not apply undercoating to any place unless specified (such as the areas above the muffler and three way catalyst which are subjected to heat).
2. Do not undercoat the exhaust pipe or other parts which become hot.
3. Do not undercoat rotating parts.
4. Apply bitumen wax after applying undercoating.

 : Indicates undercoated portions.

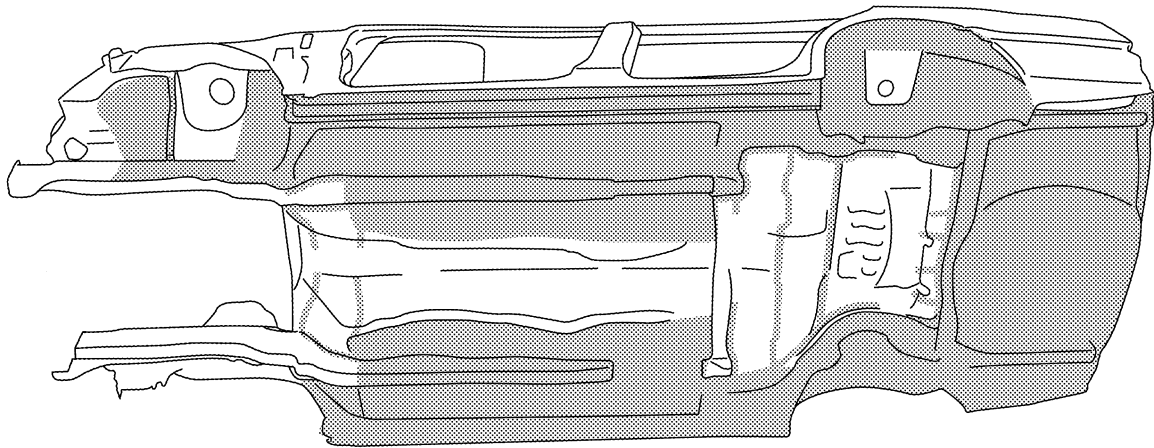

LIA0129E

BODY REPAIR

E/S008SI

Body Sealing DESCRIPTION

The following figure shows the areas which are sealed at the factory. Sealant which has been applied to these areas should be smooth and free from cuts or gaps. Care should be taken not to apply an excess amount of sealant and not to allow other unaffected parts to come into contact with the sealant.

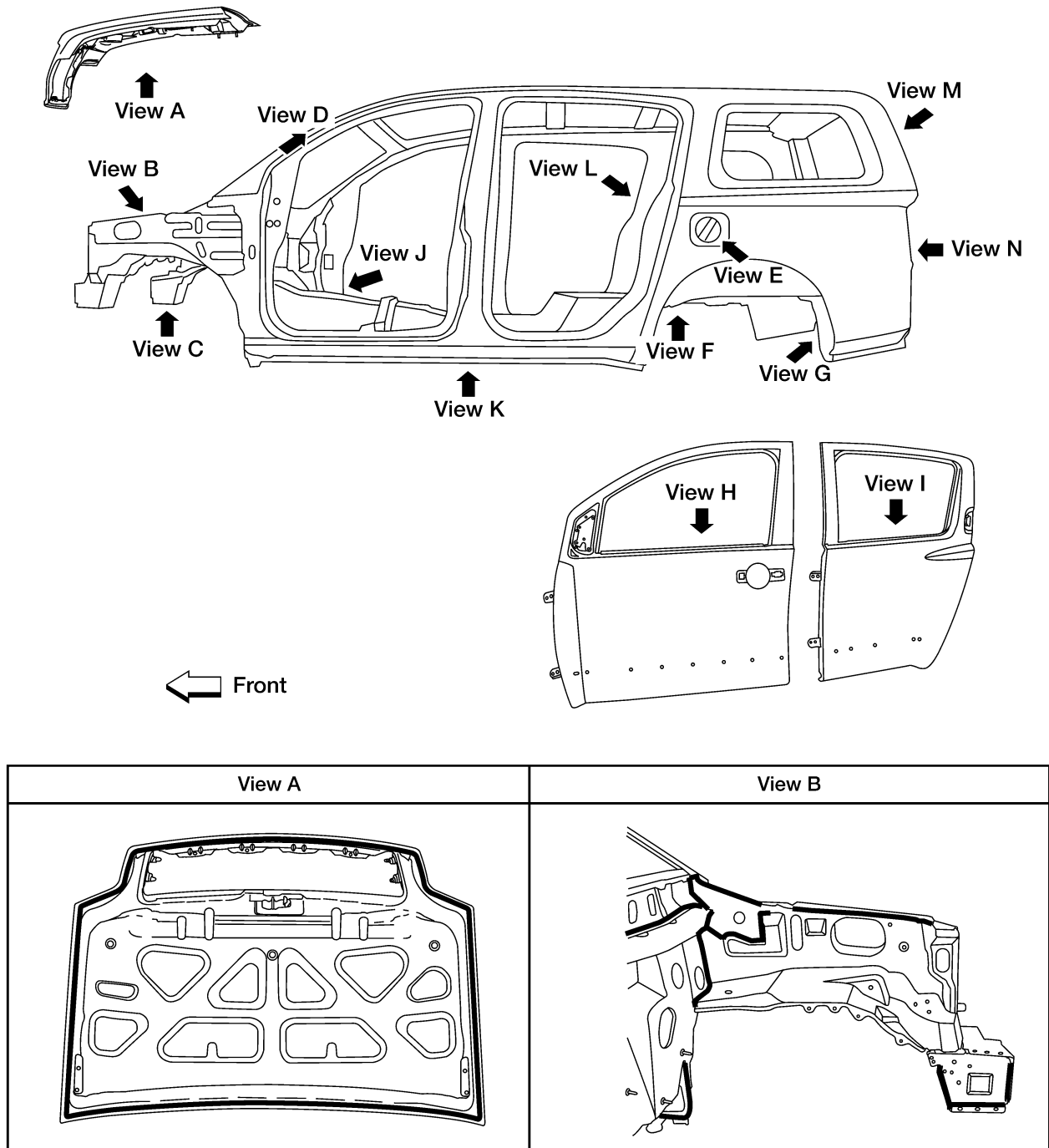

LIA1439E

BODY REPAIR

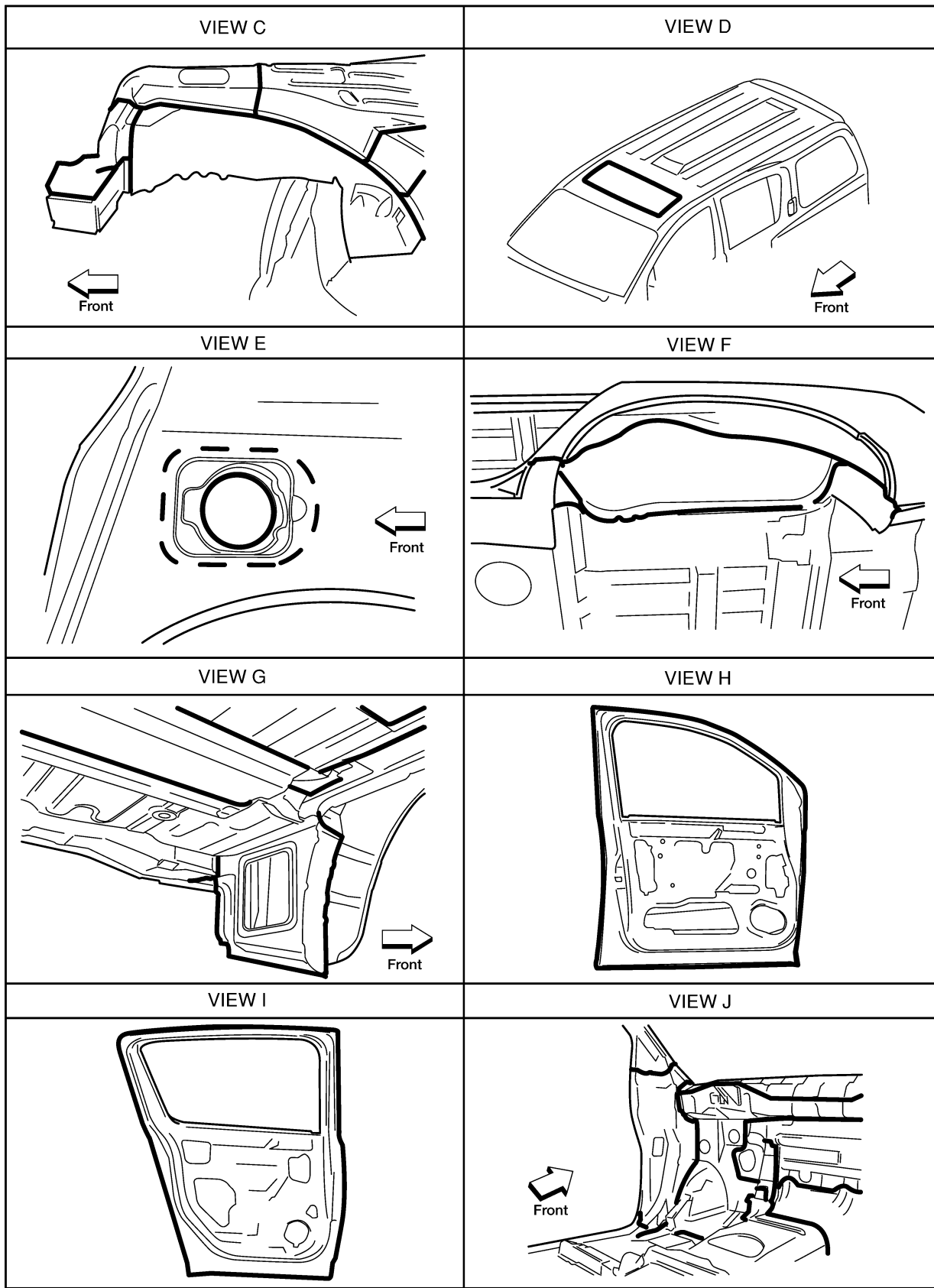

A
B
C
D
E
F
G
H
J
K
L
M

BL

W1IA0278E

BODY REPAIR

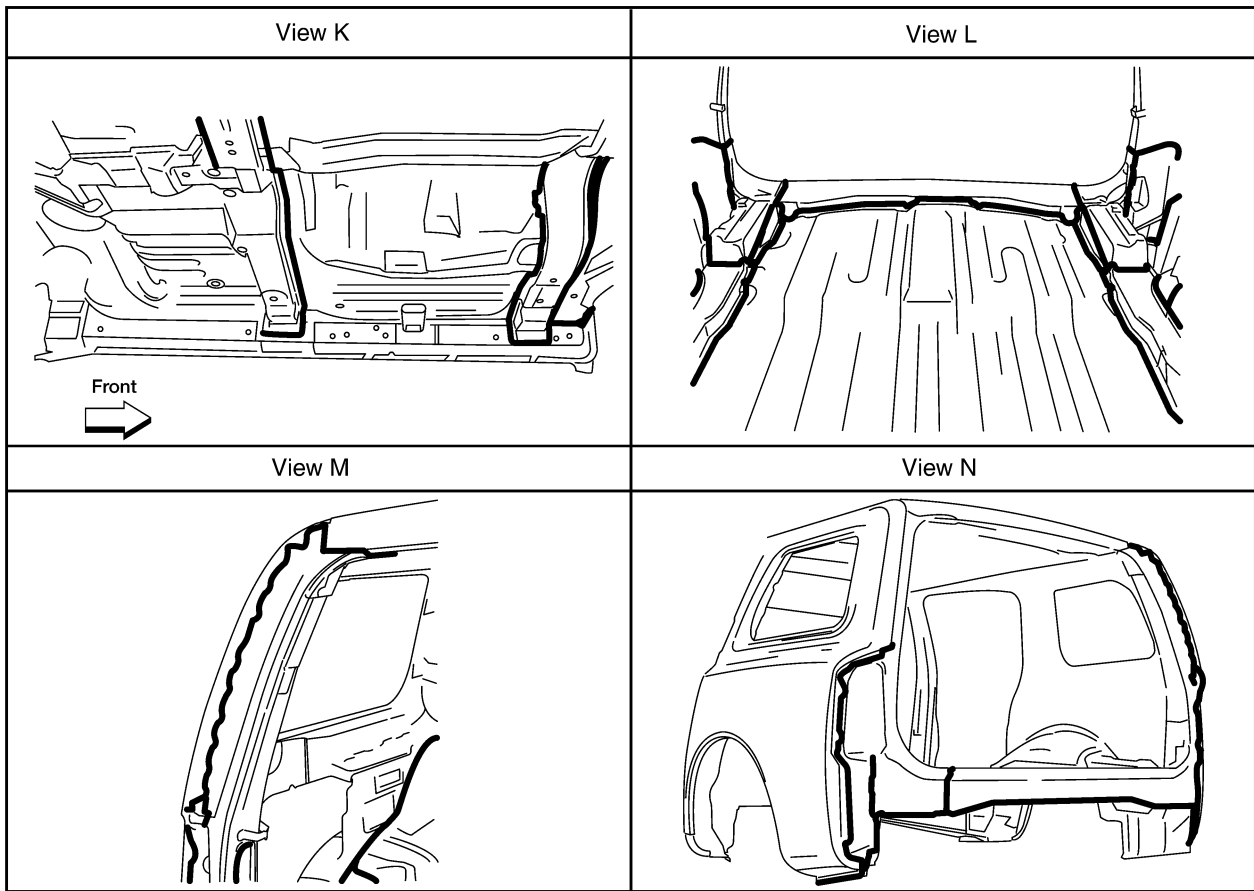

LIA0912E

BODY REPAIR

Body Construction BODY CONSTRUCTION

EIS008SJ

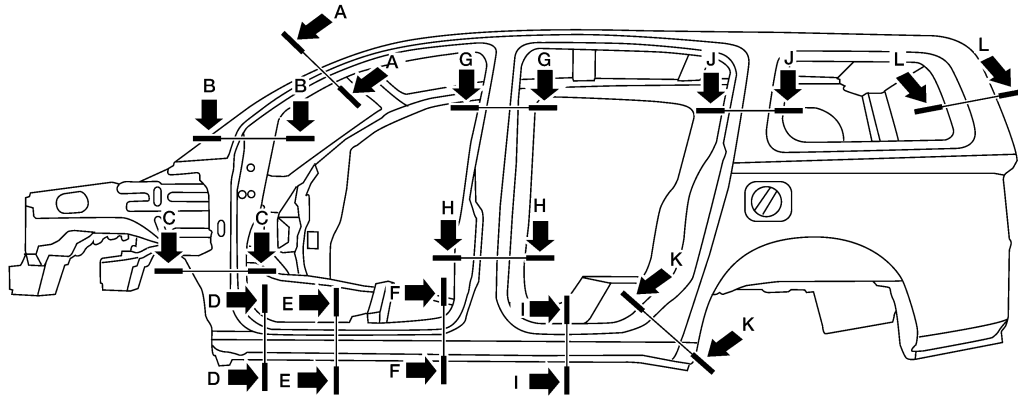

Section A-A	Section B-B	Section C-C	Section D-D
Section E-E	Section F-F	Section G-G	Section H-H
Section I-I	Section J-J	Section K-K	Section L-L

A
B
C
D
E
F
G
H
I
J
K
L
M

BL

LIA1113E

BODY REPAIR

EIS008SK

Body Alignment BODY CENTER MARKS

A mark has been placed on each part of the body to indicate the vehicle center. When repairing parts damaged by an accident which might affect the vehicle frame (members, pillars, etc.), more accurate and effective repair will be possible by using these marks together with body alignment specifications.

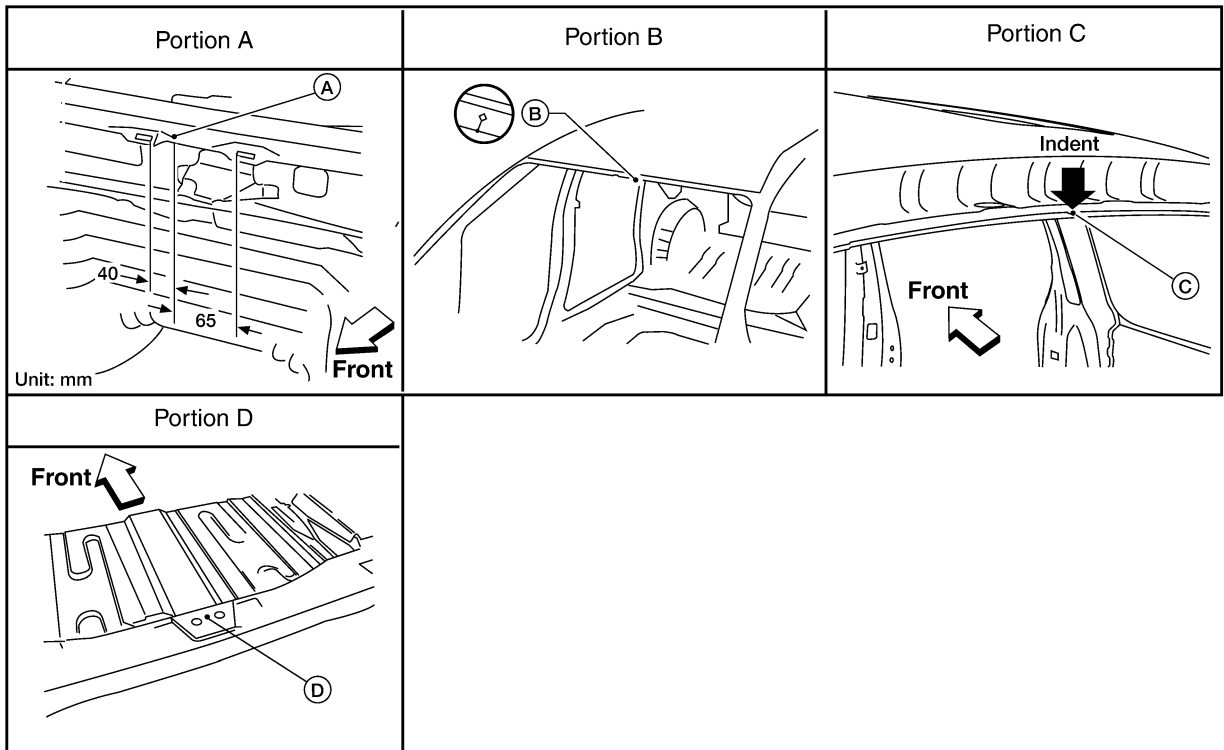
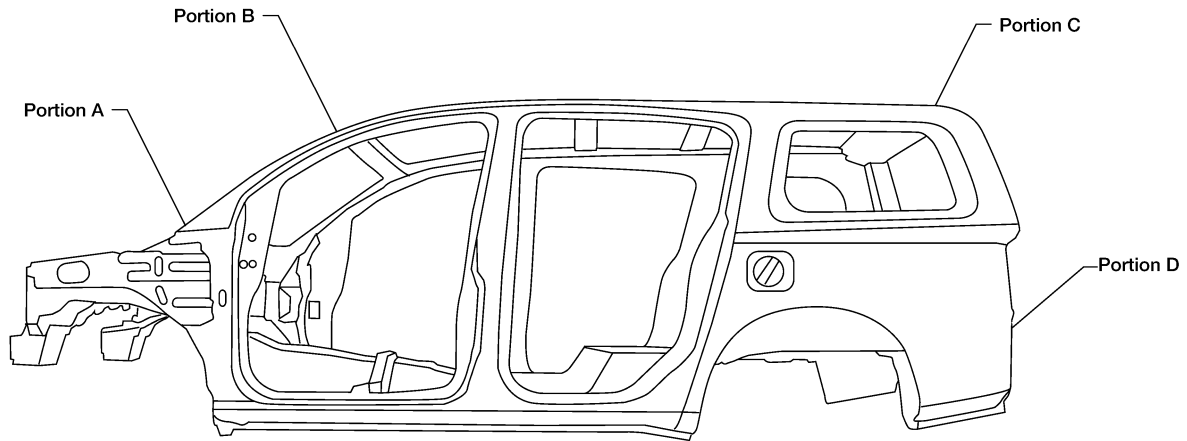

LIA1440E

BODY REPAIR

PANEL PARTS MATCHING MARKS

A mark has been placed on each body panel to indicate the parts matching positions. When repairing parts damaged by an accident which might affect the vehicle structure (members, pillars, etc.), more accurate and effective repair will be possible by using these marks together with body alignment specifications.

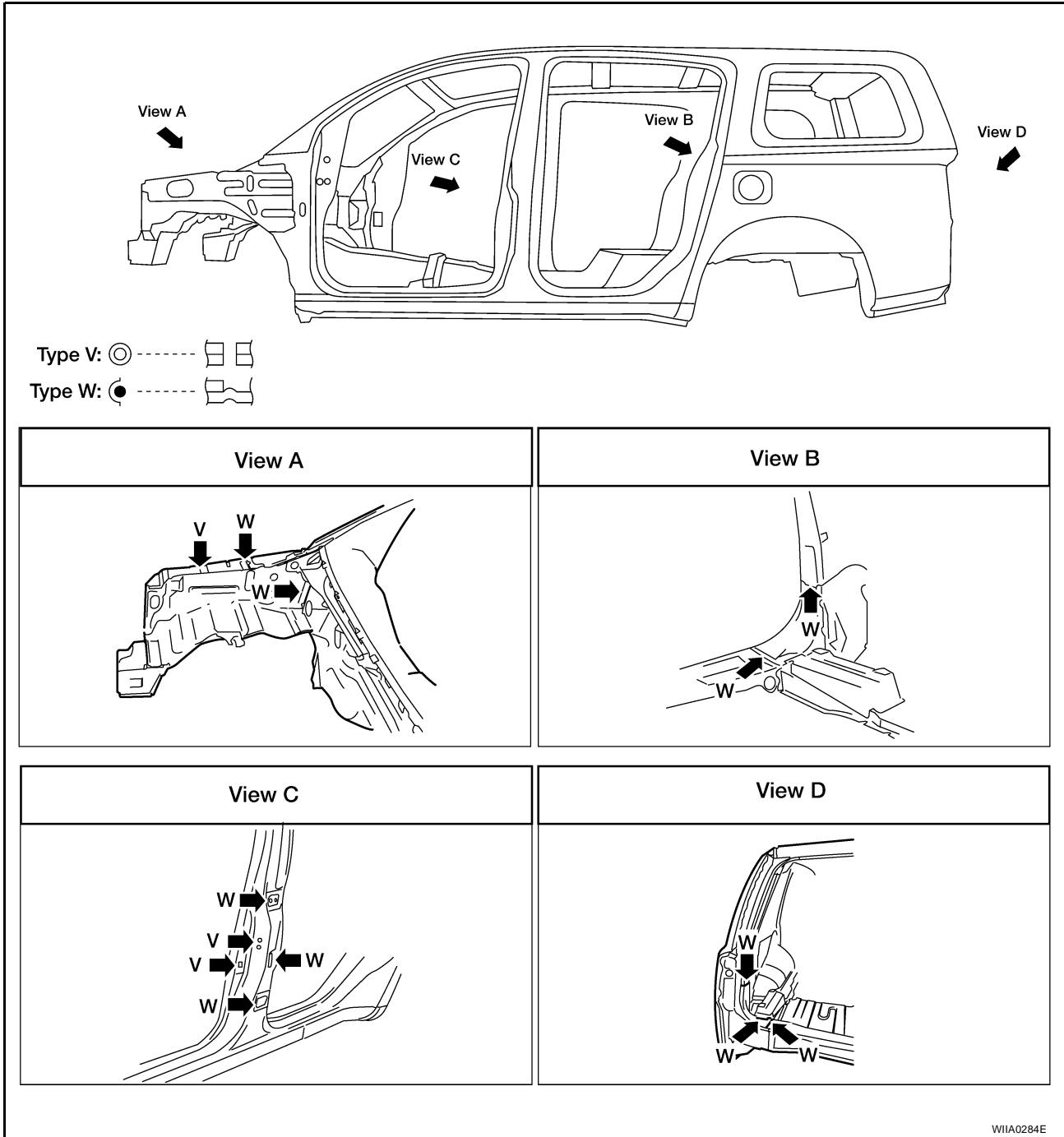

A
B
C
D
E
F
G
H
BL
J
K
L
M

BODY REPAIR

DESCRIPTION

- All dimensions indicated in the figures are actual.
- When using a tracking gauge, adjust both pointers to equal length. Then check the pointers and gauge itself to make sure there is no free play.
- When a measuring tape is used, check to be sure there is no elongation, twisting or bending.
- Measurements should be taken at the center of the mounting holes.
- An asterisk (*) following the value at the measuring point indicates that the measuring point on the other side is symmetrically the same value.
- The coordinates of the measurement points are the distances measured from the standard line of "X", "Y" and "Z".

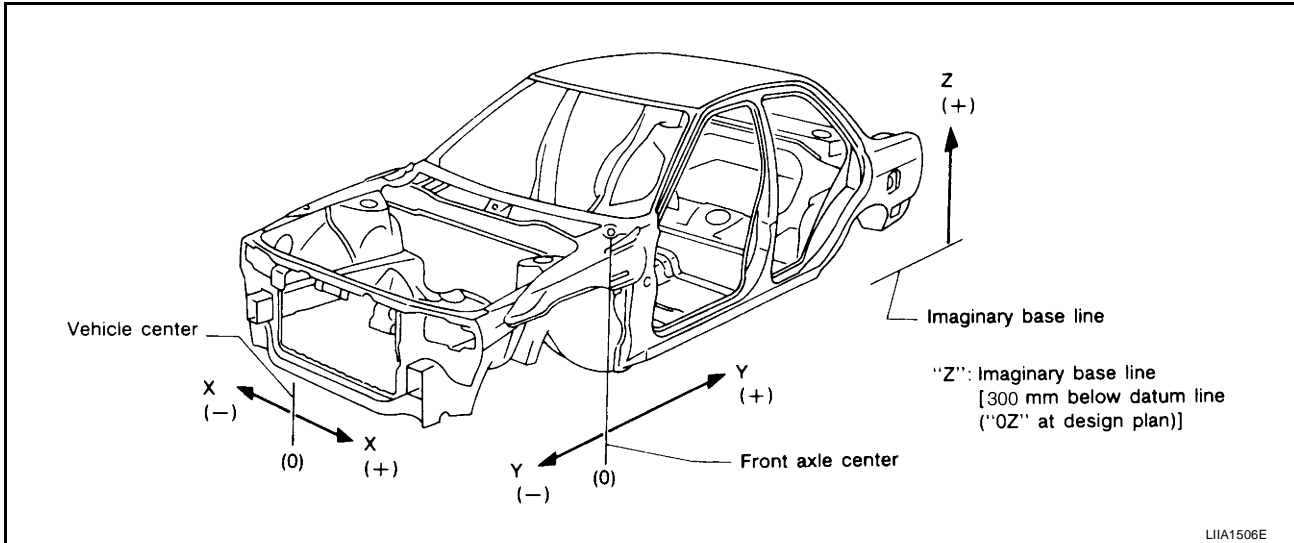

BODY REPAIR

ENGINE COMPARTMENT MEASUREMENT

Figures marked with a (*) indicate symmetrically identical dimensions on both right and left hand sides of the vehicle.

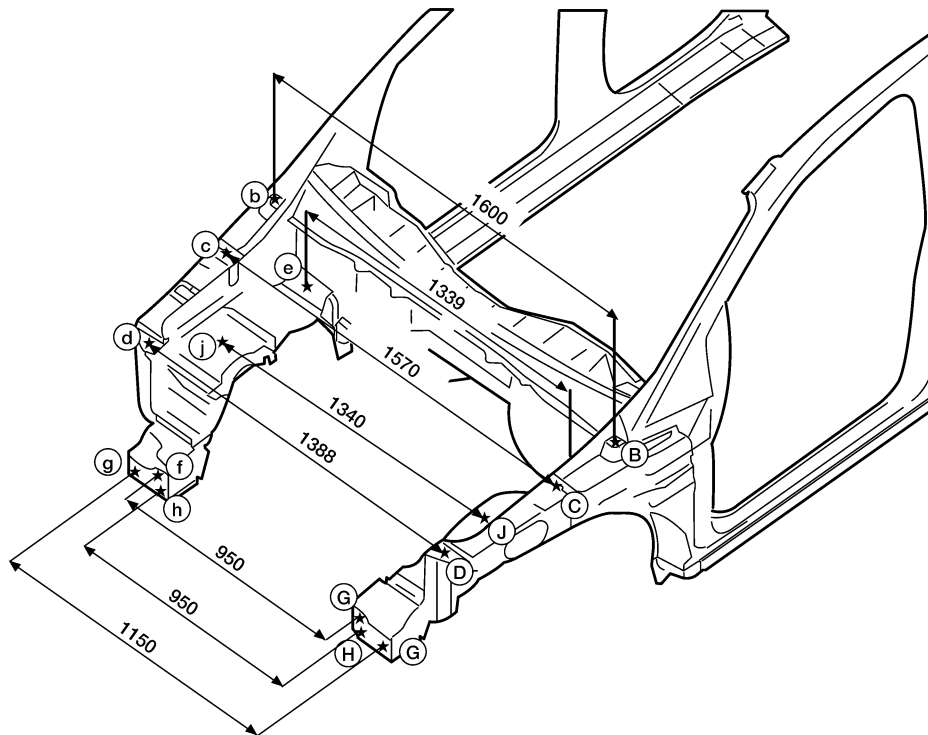
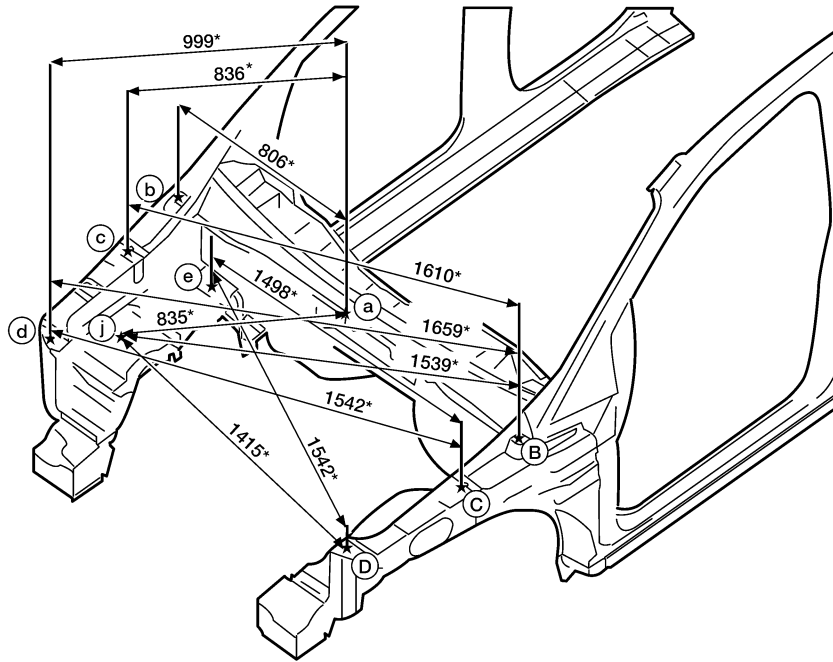

Unit: mm

W1A0551E

A
B
C
D
E
F
G
H
BL
J
K
L
M

BODY REPAIR

MEASUREMENT POINTS

- ⓑ Fender mount
- ⓒ Fender mount
- ⓓ Front end module mount
- ⓔ 18mm x 16mm diameter
- ⓙ 16mm diameter

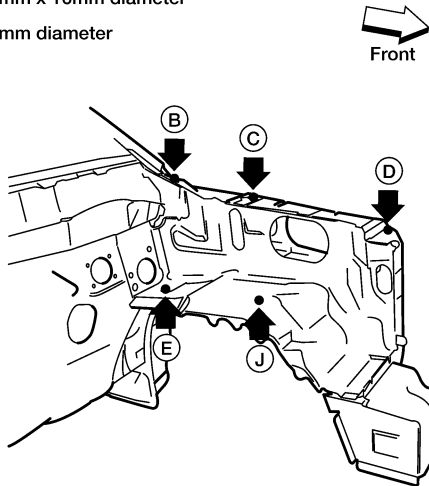

- ⓐ RH cowl
- ⓑ Fender mount
- ⓒ Fender mount
- ⓓ Front end module mount
- ⓔ 18mm x 16mm diameter
- ⓙ 16 mm diameter

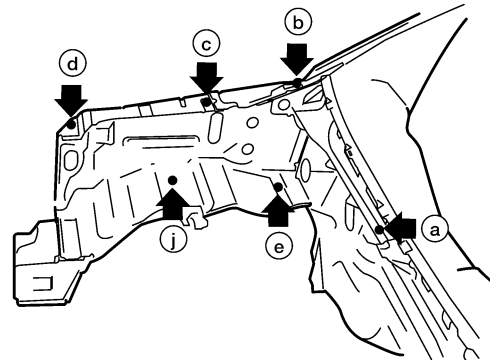

- ⓕ, ⓕ, ⓖ, ⓖ, ⓗ, ⓗ Front side member extension front

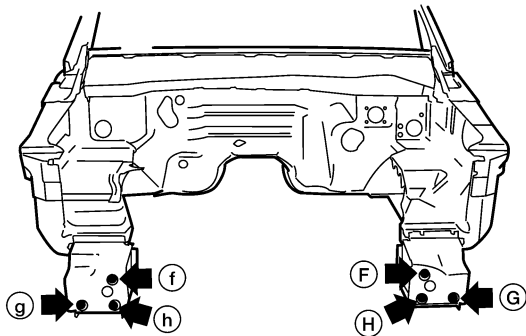

WIHA0279E

BODY REPAIR

UNDERBODY MEASUREMENT

Figures marked with a (*) indicate symmetrically identical dimensions on both right and left hand sides of the vehicle.

As viewed from underside.

All dimensions indicated in this figure are actual.

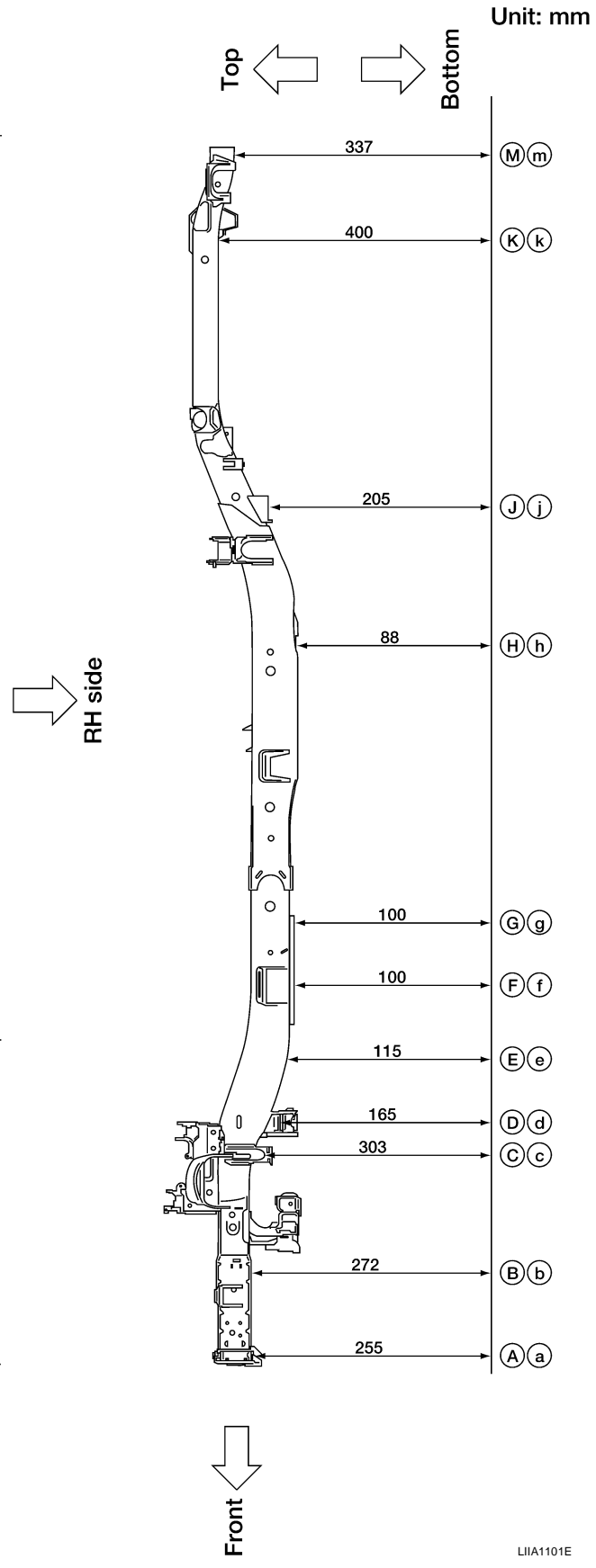
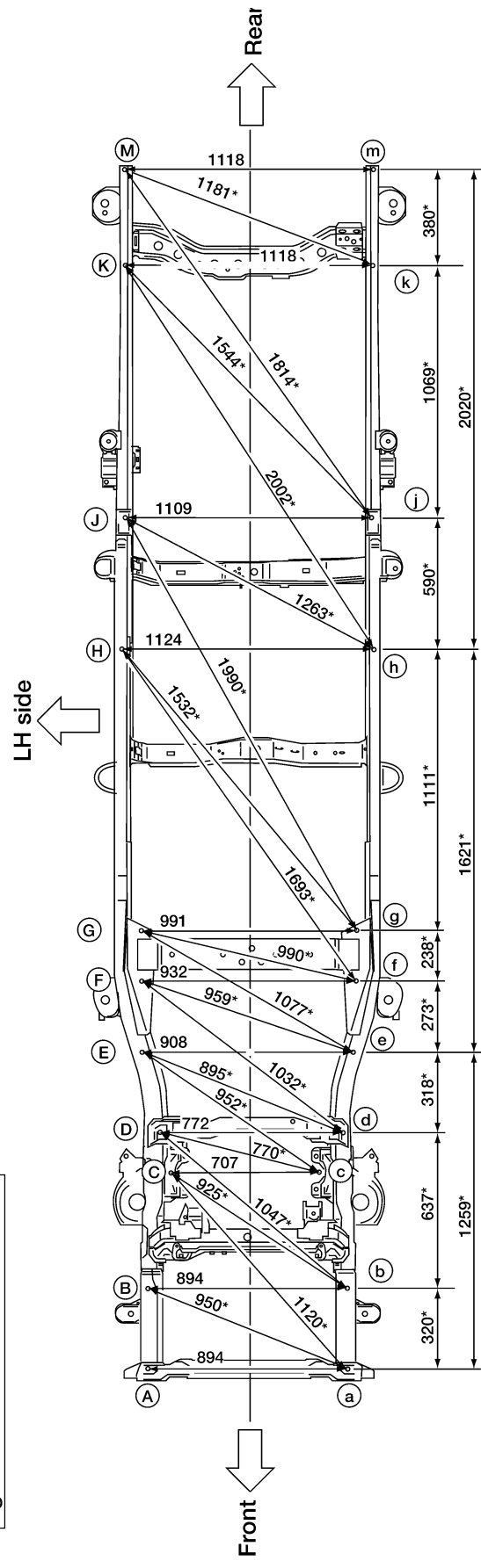

A
B
C
D
E
F
G
H
J
K
L
M

BL

BODY REPAIR

MEASUREMENT POINTS

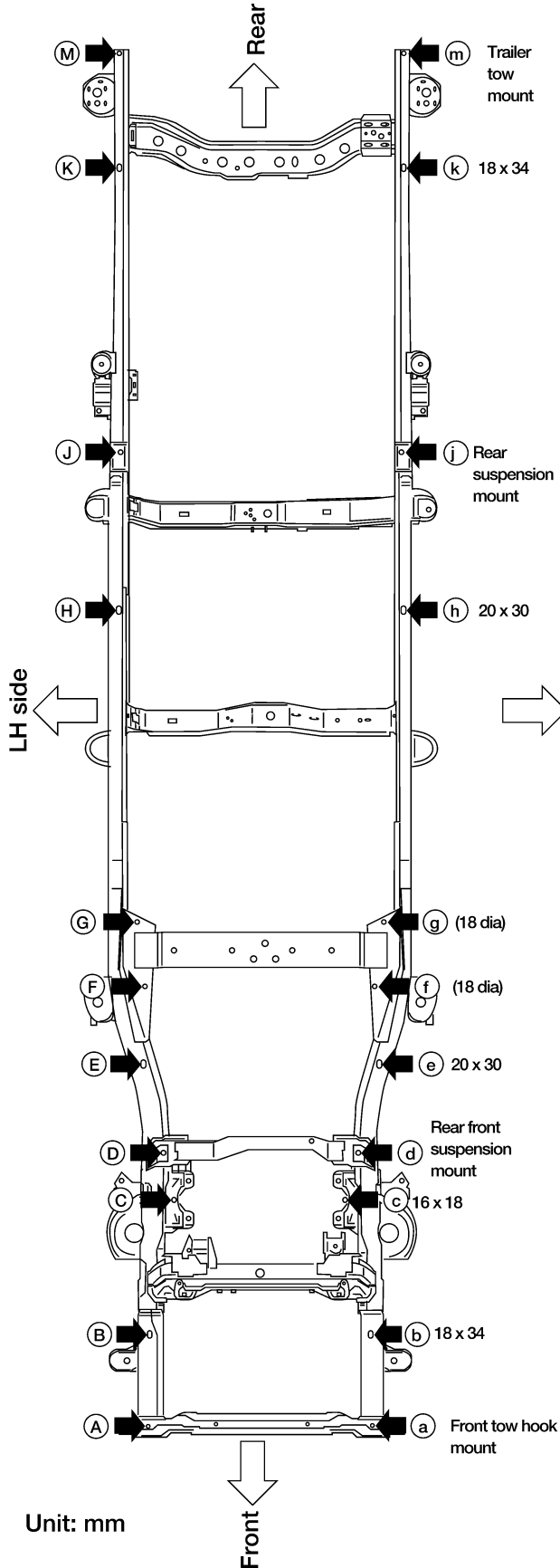

Coordinates:

- (A), (a)
X: ± 447
Y: -745
Z: 255
- (B), (b)
X: ± 447
Y: -427
Z: 272
- (C), (c)
X: ± 353
Y: 35
Z: 303
- (D), (d)
X: ± 386
Y: 198
Z: 165
- (E), (e)
X: ± 454
Y: 504
Z: 115
- (F), (f)
X: ± 466
Y: 777
Z: 100
- (G), (g)
X: ± 495
Y: 1013
Z: 100
- (H), (h)
X: ± 562
Y: 2122
Z: 88
- (J), (j)
X: ± 555
Y: 2700
Z: 205
- (K), (k)
X: ± 559
Y: 3751
Z: 400
- (M), (m)
X: ± 559
Y: 4126
Z: 337

LIA1508E

BODY REPAIR

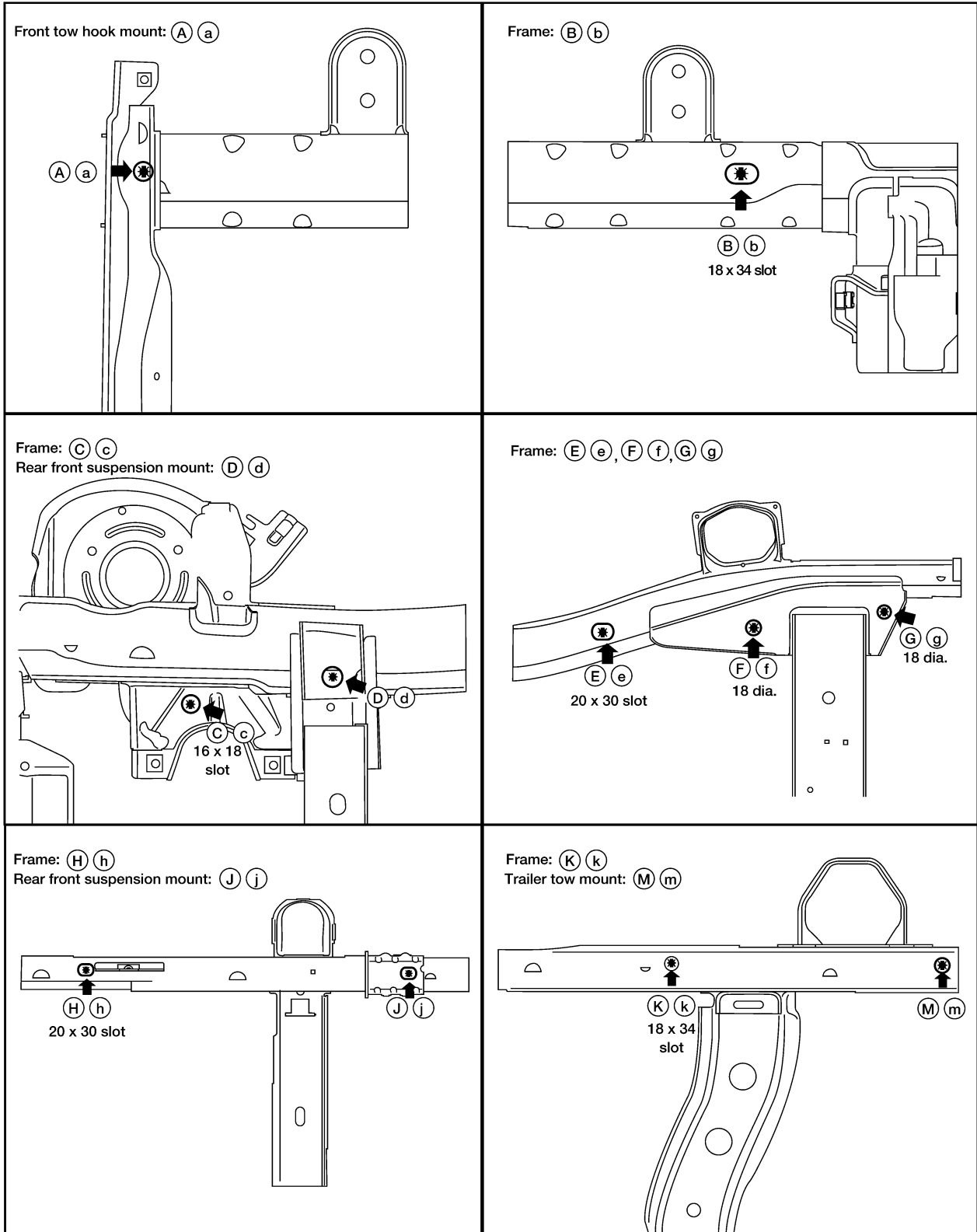

A
B
C
D
E
F
G
H
BL
J
K
L
M

Coordinates:	(A) (a)	(B) (b)	(C) (c)	(D) (d)	(E) (e)	(F) (f)	(G) (g)	(H) (h)	(J) (j)	(K) (k)	(M) (m)
X :	± 447	± 447	± 353	± 386	± 454	± 466	± 495	± 562	± 555	± 559	± 559
Y :	-747	-427	35	198	504	777	1013	2122	2700	3751	4126
Z :	255	272	303	165	115	100	100	88	205	400	337

Unit: mm

LIA1509E

BODY REPAIR

PASSENGER COMPARTMENT MEASUREMENT

Figures marked with a (*) indicate symmetrically identical dimensions on both right and left hand sides of the vehicle.

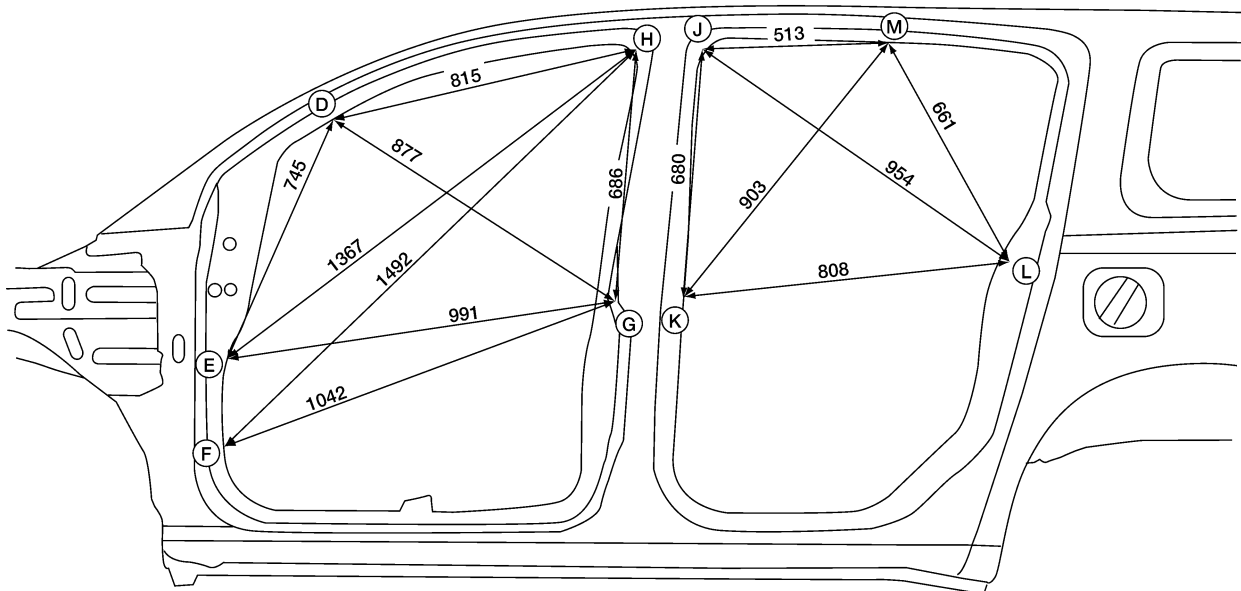
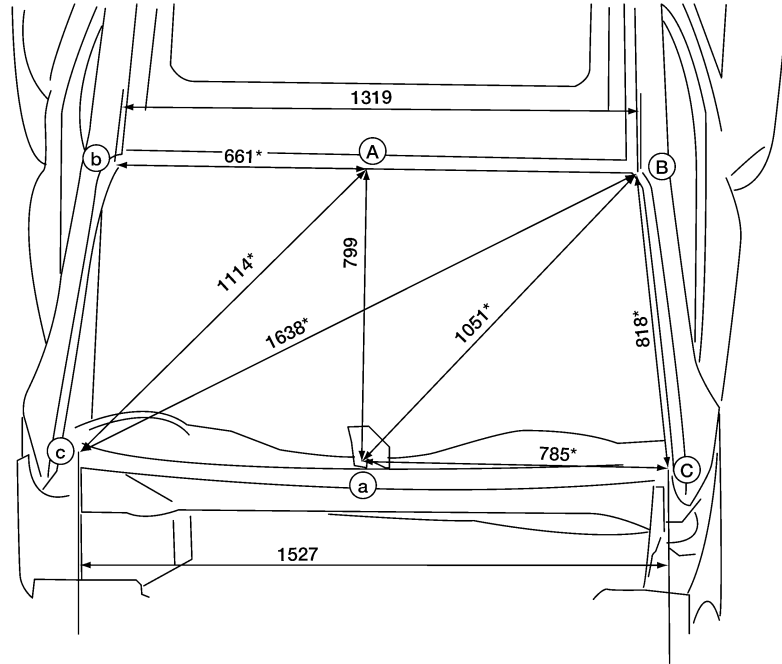

Unit: mm

LIA1510E

BODY REPAIR

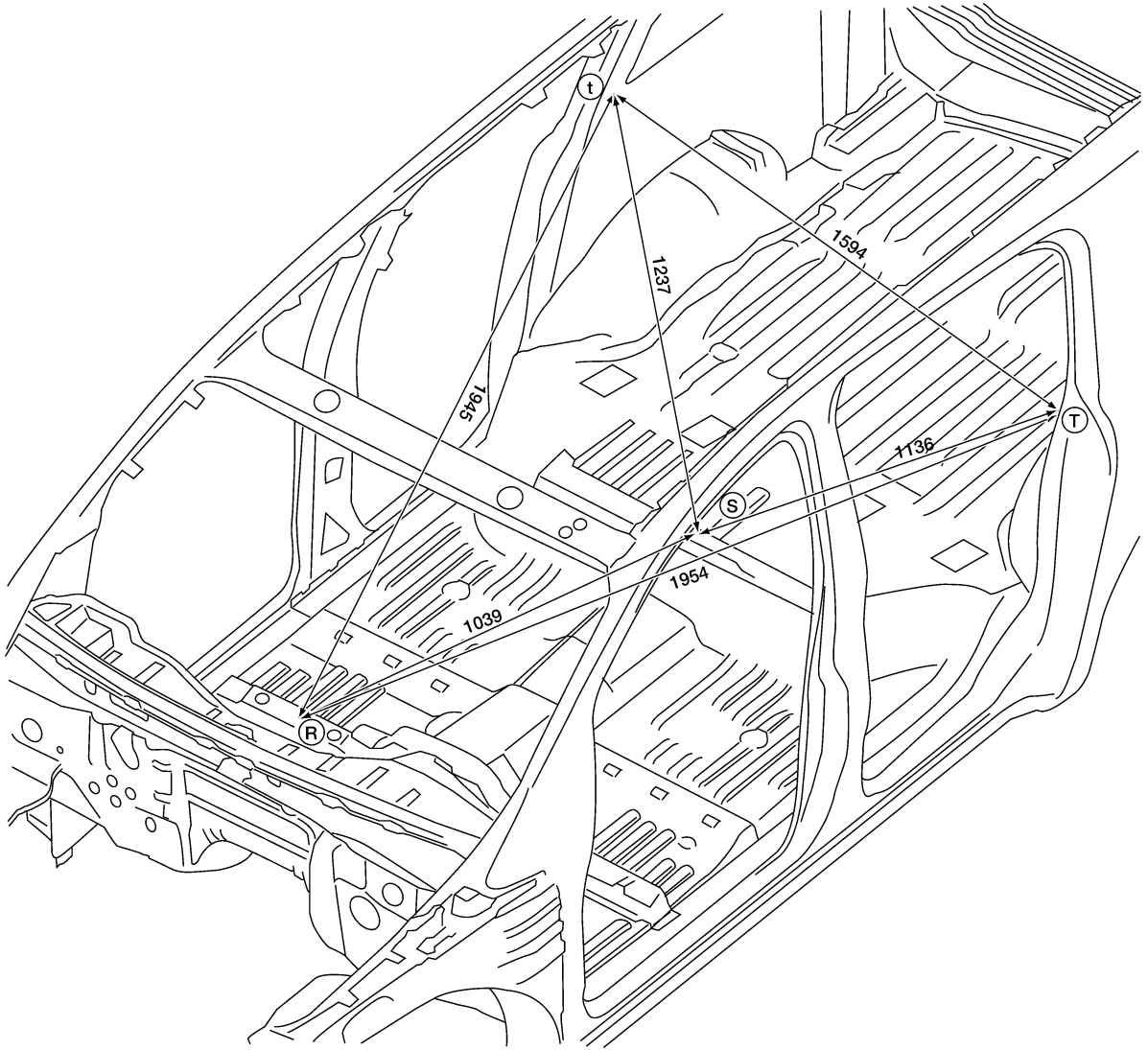

A
B
C
D
E
F
G
H
BL
J
K
L
M

Unit : mm

LIA1105E

BODY REPAIR

MEASUREMENT POINTS

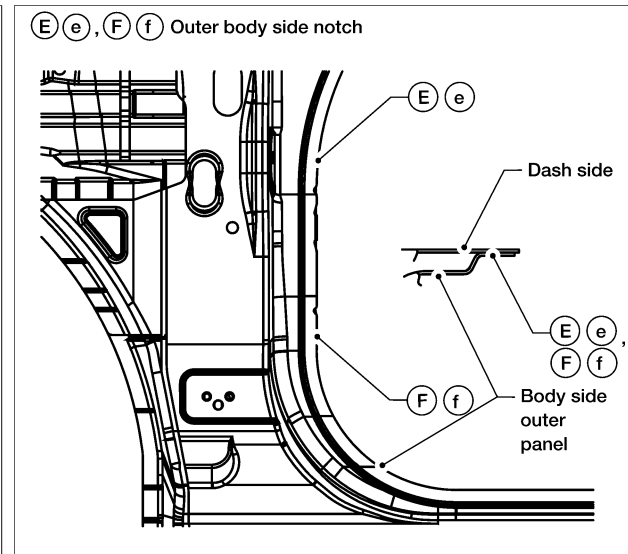
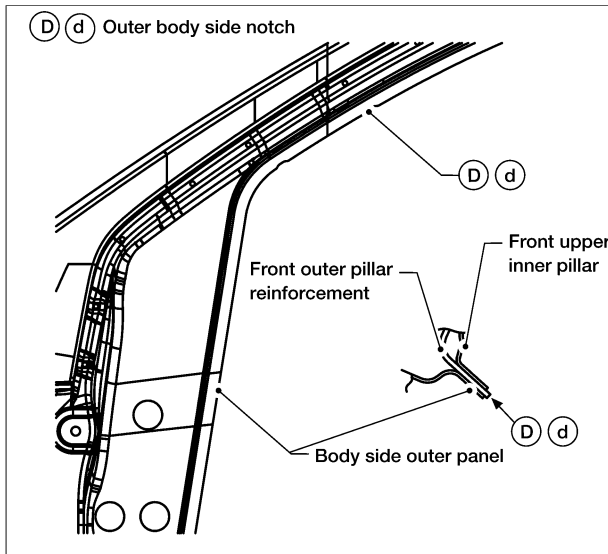
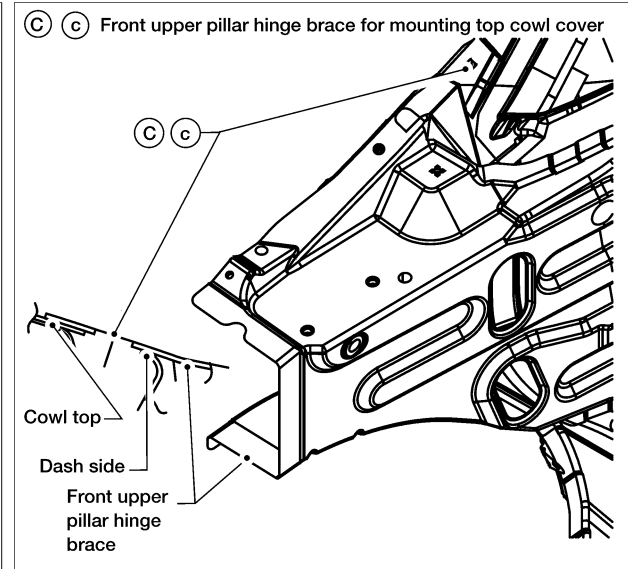
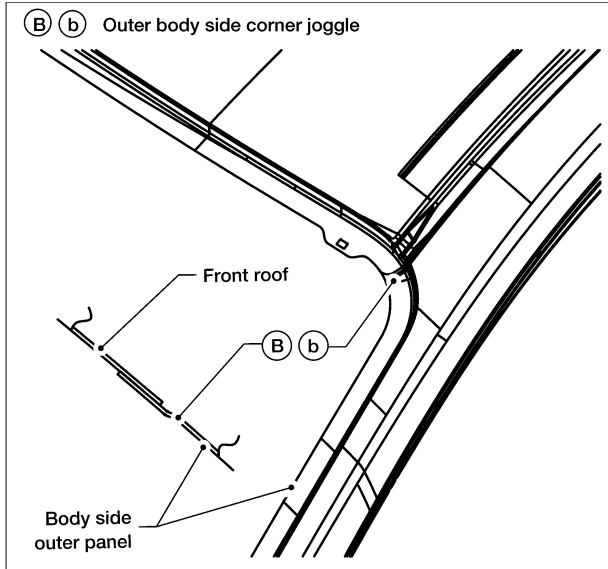
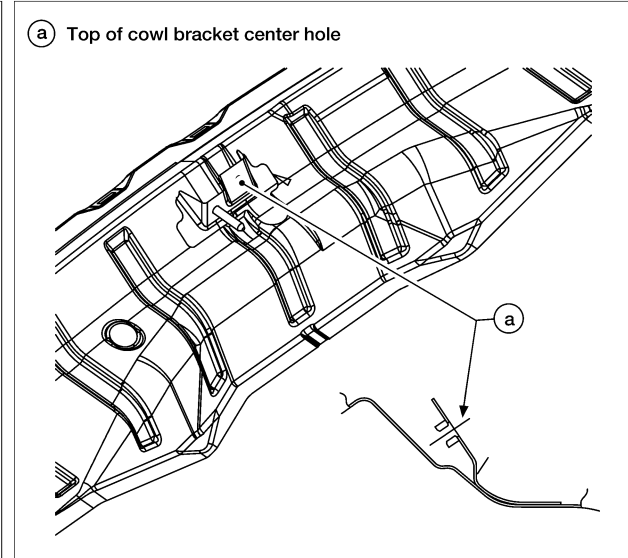
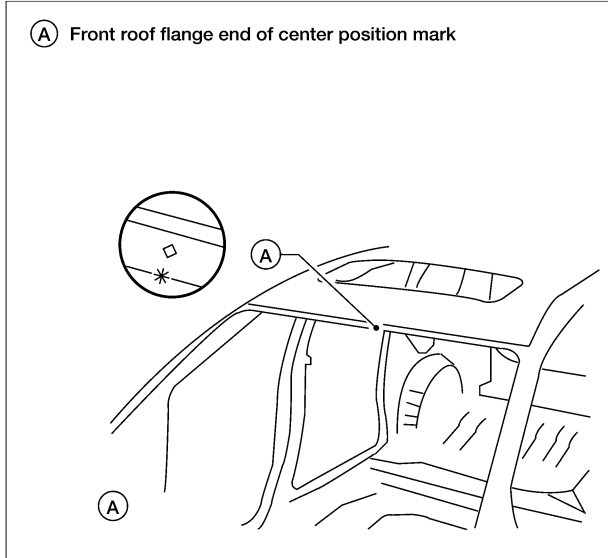

LIA1103E

BODY REPAIR

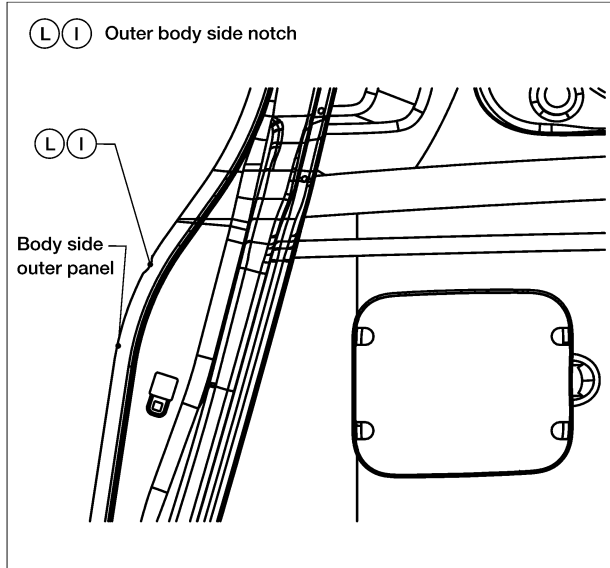
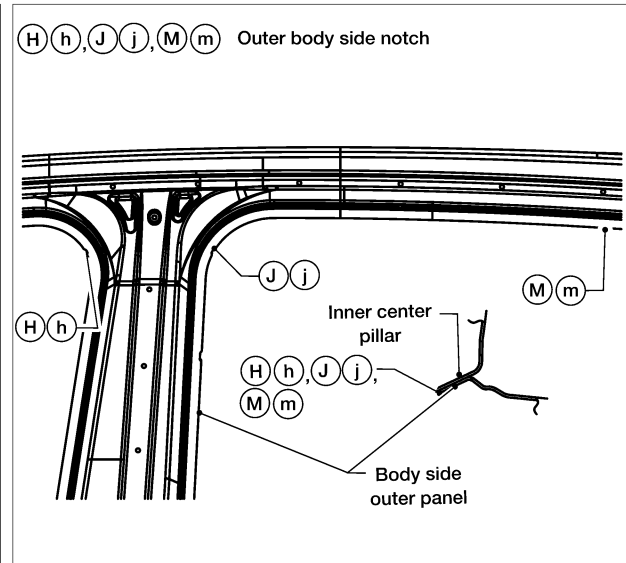
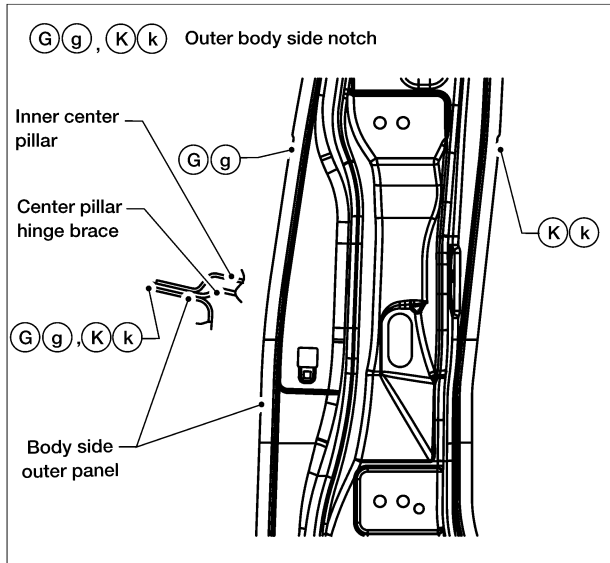

A
B
C
D
E
F
G
H
BL
J
K
L
M

LIIA1104E

BODY REPAIR

(R) Front seat crossmember front

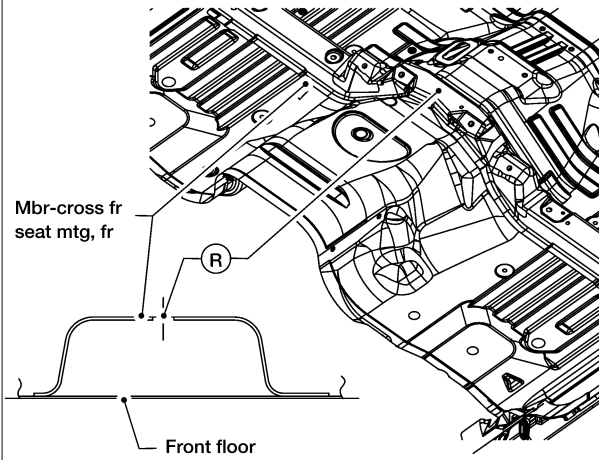

(S) 2nd seat crossmember front

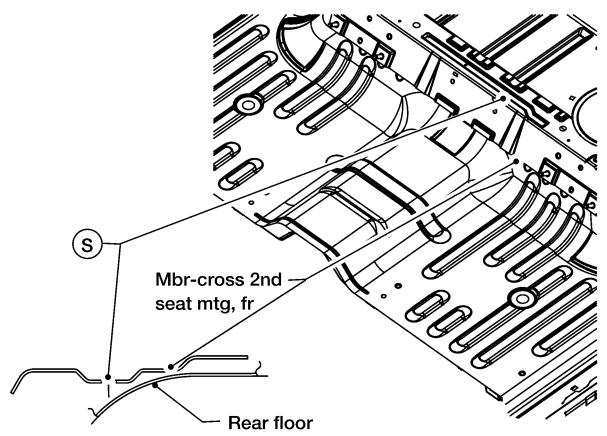

(T t) Inner side panel for seat belt anti-rotate

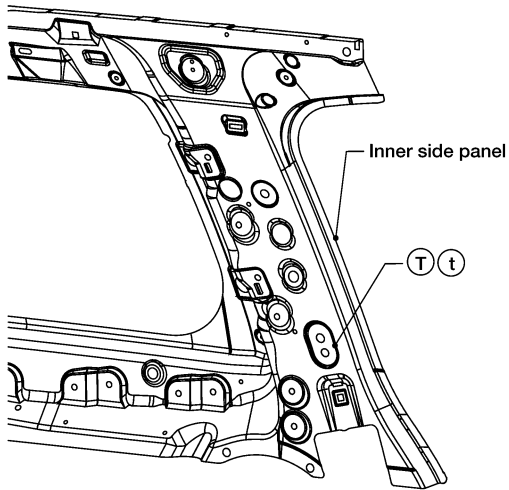

LIA1106E

BODY REPAIR

REAR BODY MEASUREMENT

Figures marked with a (*) indicate symmetrically identical dimensions on both right and left hand sides of the vehicle.

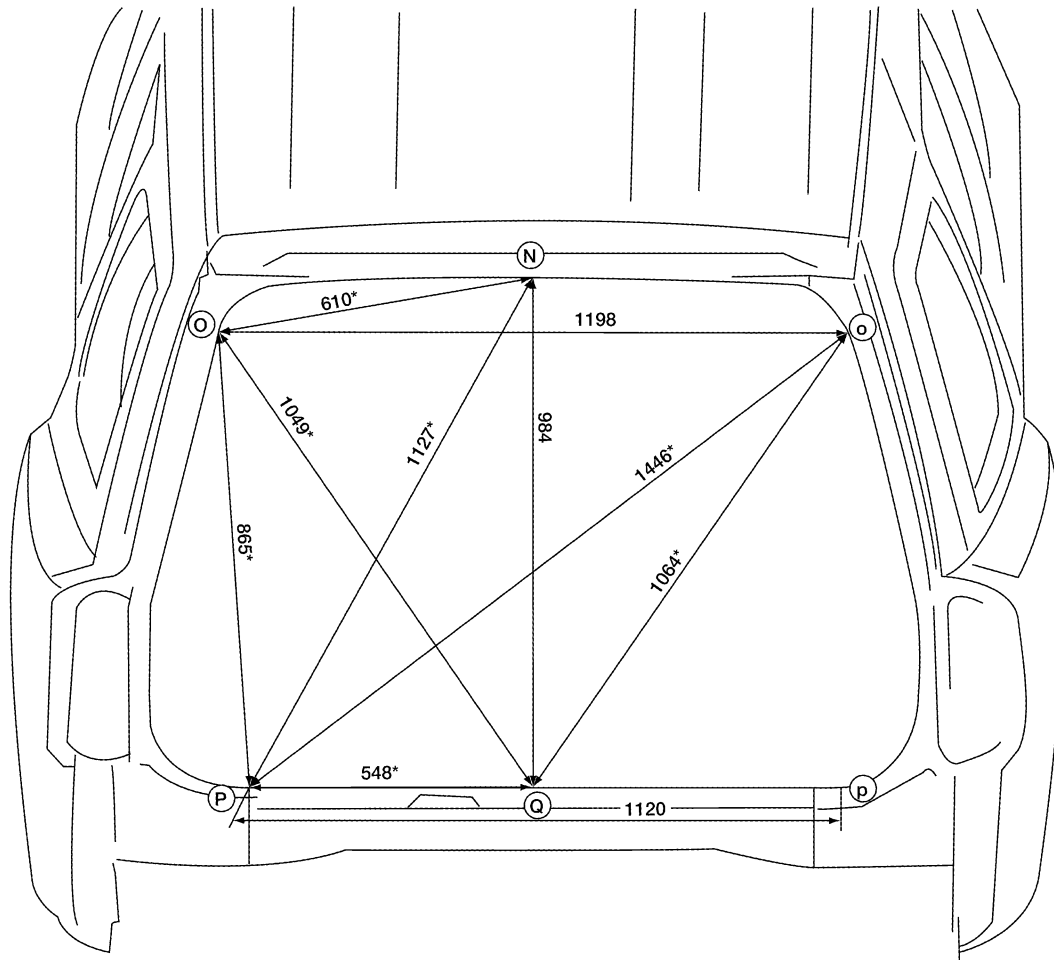

A
B
C
D
E
F
G
H
BL
J
K
L
M

Unit: mm

LIA1511E

BODY REPAIR

MEASUREMENT POINTS

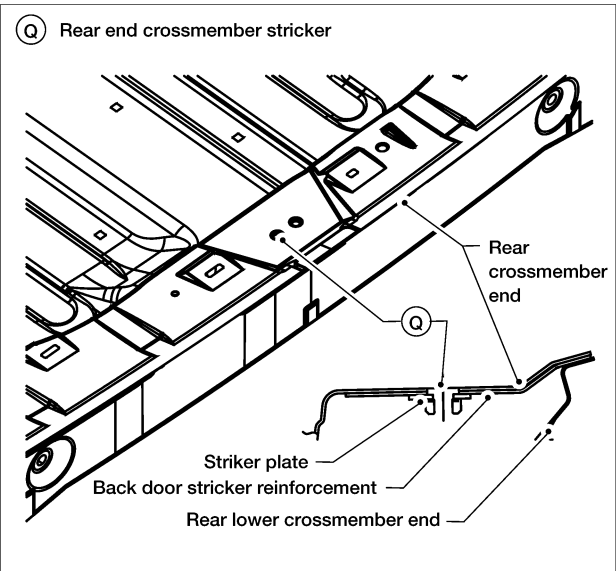
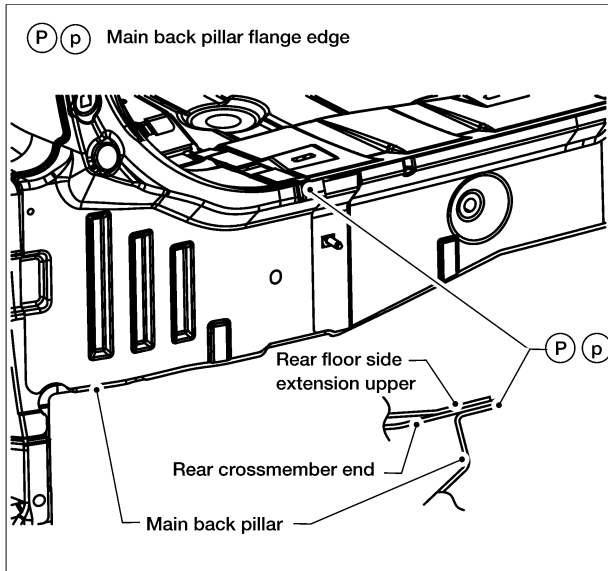
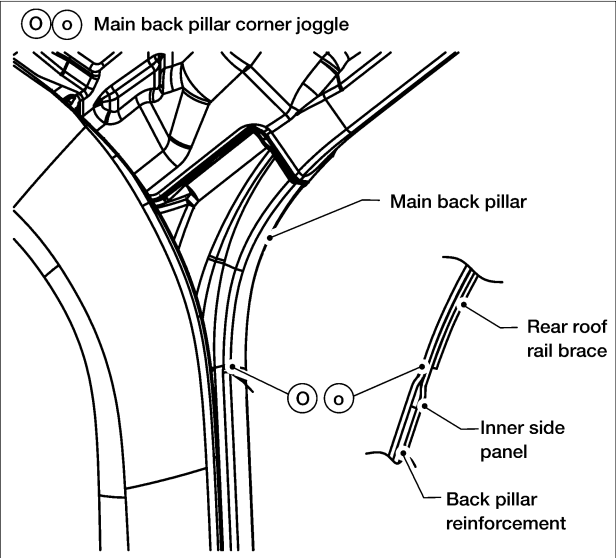
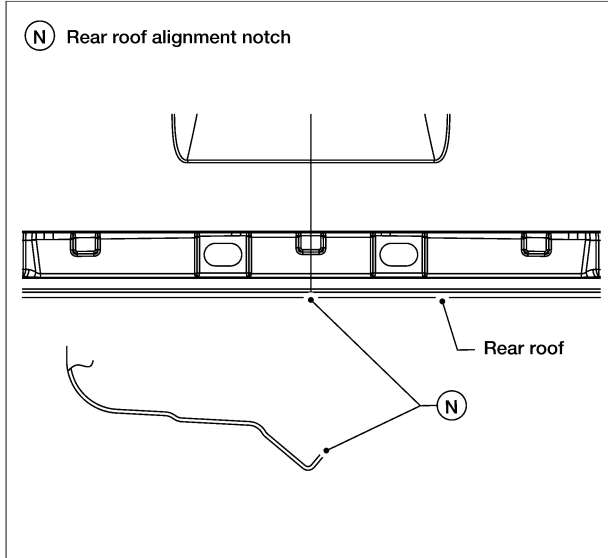

W11A0280E

BODY REPAIR

EIS008SL

Handling Precautions for Plastics HANDLING PRECAUTIONS FOR PLASTICS

Abbreviation	Material name	Heatresisting temperature °C (°F)	Resistance to gasoline and solvents	Other cautions
PE	Polyethylene	60 (140)	Gasoline and most solvents are harmless if applied for a very short time (wipe up quickly).	Flammable
PVC	Polyvinyl Chloride	80 (176)	Same as above.	Poison gas is emitted when burned.
EPM/EPDM	Ethylene Propylene (Diene) rubber	80 (176)	Same as above.	Flammable
TPO/TPR	Thermoplastic Olefine/Thermoplastic Rubber	80 (176)	Same as above.	Flammable
PP	Polypropylene	90 (194)	Same as above.	Flammable, avoid battery acid.
UP	Polyester thermoset	90 (194)	Same as above.	Flammable
PS	Polystyrene	80 (176)	Avoid solvents.	Flammable
ABS	Acrylonitrile Butadiene Styrene resin	80 (176)	Avoid gasoline and solvents.	
AES	Acrylonitrile Ethylene Styrene	80 (176)	Same as above.	
PMMA	Polymethyl Methacrylate	85 (185)	Same as above.	
AAS	Acrylonitrile Acrylic Styrene	85 (185)	Same as above.	
AS	Acrylonitrile Styrene	85 (185)	Same as above.	
EVA	Polyvinyl Ethyl Acetate	90 (194)	Same as above.	
ASA	Acrylonitrile Styrene Acrylate	100 (222)	Same as above.	Flammable
PPO/PPE	Polyphenylene Oxide/ Polyphenylene Ether	110 (230)	Same as above.	
PC	Polycarbonate	120 (248)	Same as above.	
PAR	Polyacrylate	180 (356)	Same as above.	
L-LDPE	Linear Low Density PE	45 (100)	Gasoline and most solvents are harmless.	Flammable
PUR	Polyurethane	90 (194)	Same as above.	
TPU	Thermoplastic Urethane	110 (230)	Same as above.	
PPC	Polypropylene Composite	115 (239)	Same as above.	Flammable
POM	Polyacetal	120 (248)	Same as above.	Avoid battery acid.
PBT+PC	Polybutylene Terephthalate+Polycarbonate	120 (248)	Same as above.	Flammable
PA	Polyamide (Nylon)	140 (284)	Same as above.	Avoid immersing in water.
PBT	Polybutylene Terephthalate	140 (284)	Same as above.	
FRP	Fiber Reinforced Plastics	170 (338)	Same as above.	Avoid battery acid.
PET	Polyethylene Terephthalate	180 (356)	Same as above.	
PEI	Polyetherimide	200 (392)	Same as above.	

1. When repairing and painting a portion of the body adjacent to plastic parts, consider their characteristics (influence of heat and solvent) and remove them if necessary or take suitable measures to protect them.
2. Plastic parts should be repaired and painted using methods suiting the materials' characteristics.

BODY REPAIR

LOCATION OF PLASTIC PARTS

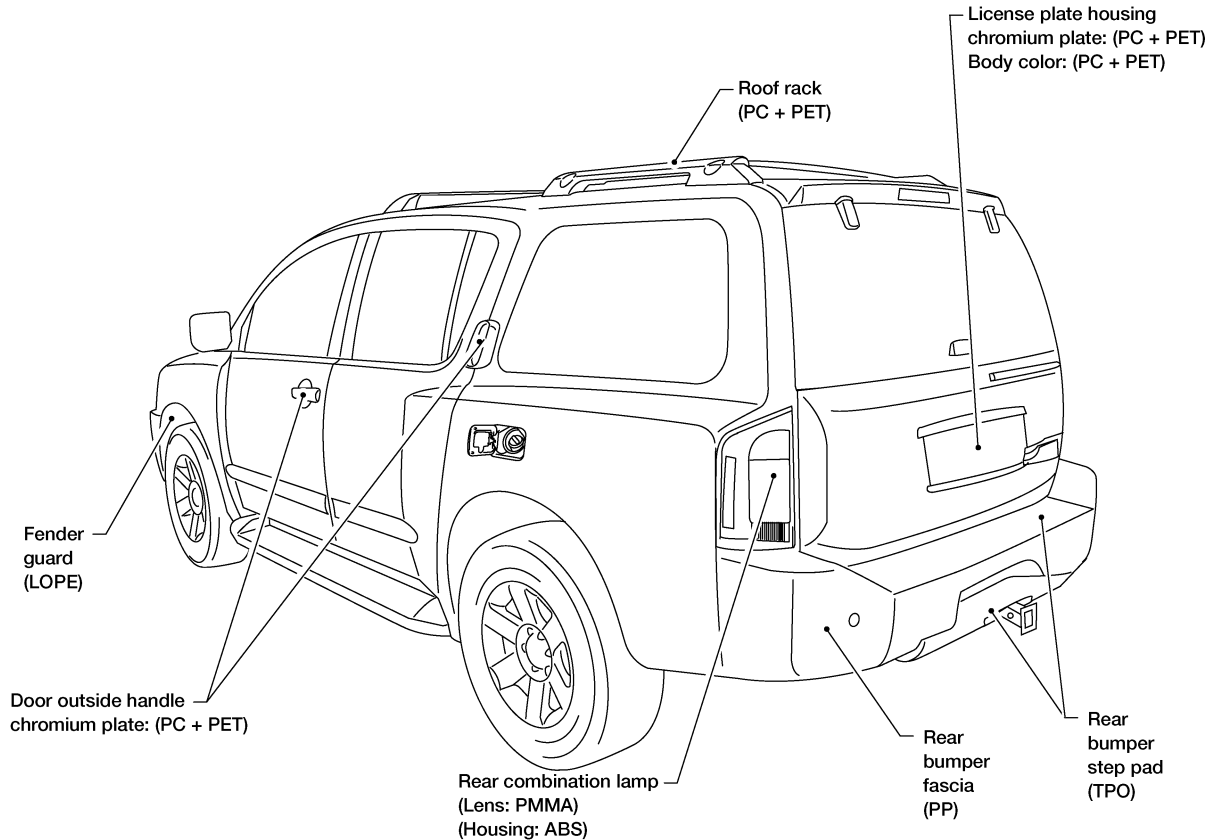
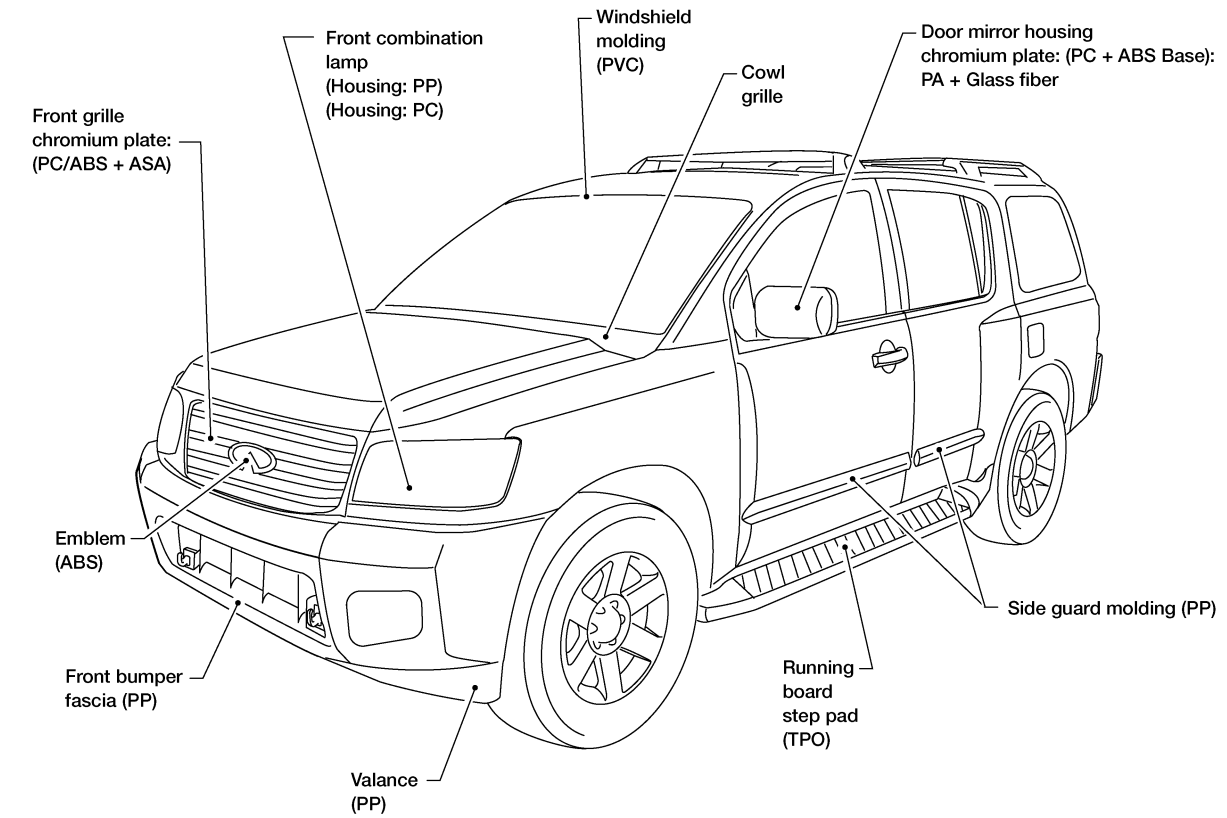

LIA1441E

BODY REPAIR

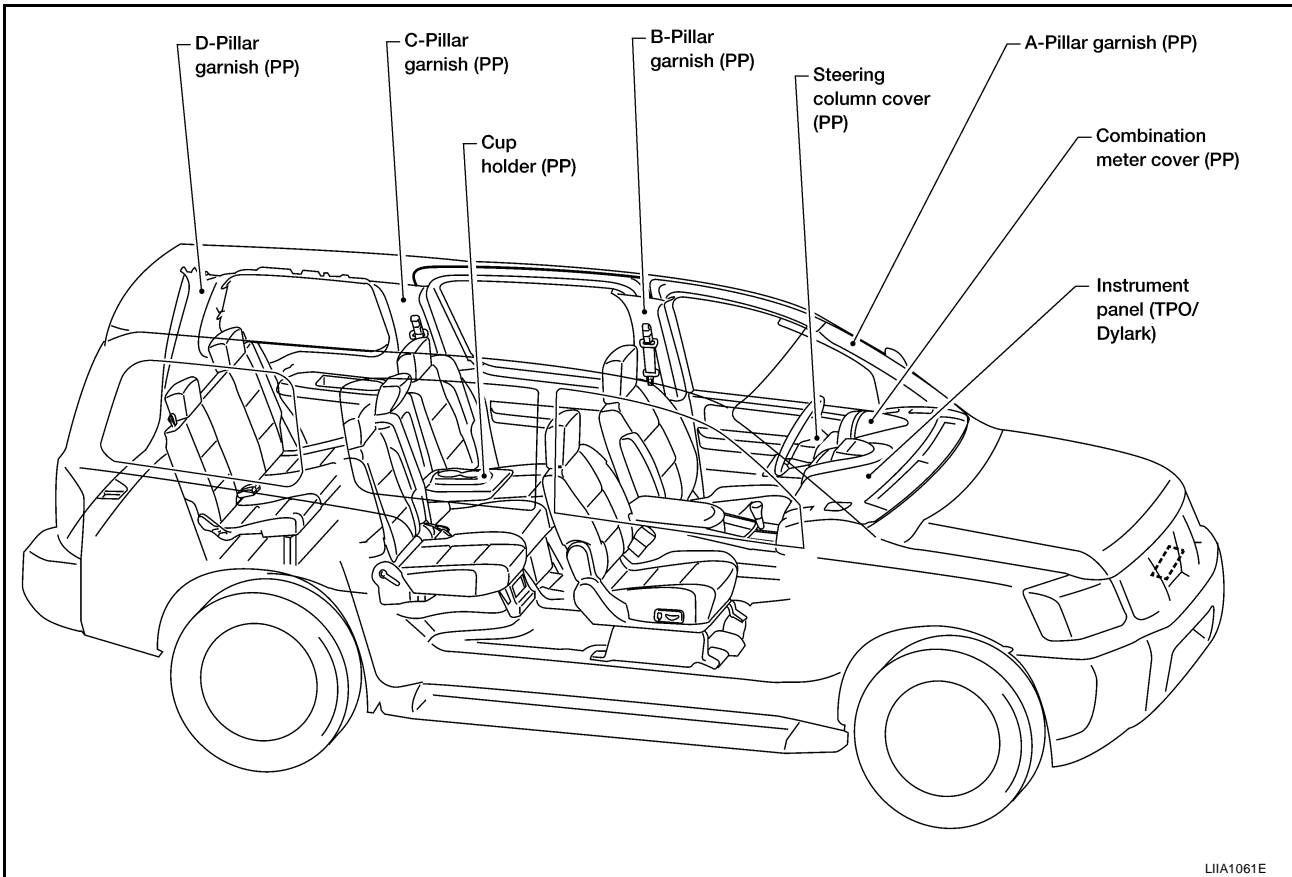

A

B

C

D

E

F

G

H

BL

J

K

L

M

BODY REPAIR

EIS008SM

Precautions in Repairing High Strength Steel

High strength steel is used for body panels in order to reduce vehicle weight.

Accordingly, precautions in repairing automotive bodies made of high strength steel are described below:

HIGH STRENGTH STEEL (HSS) USED IN NISSAN VEHICLES

Tensile strength	Nissan/Infiniti designation	Major applicable parts
373 N/mm ² (38kg/mm ² ,54klb/sq in)	SP130	<ul style="list-style-type: none"> ● Front inner pillar upper ● Front pillar hinge brace ● Outer front pillar reinforcement ● Other reinforcements
785-981 N/mm ² (80-100kg/mm ² 114-142klb/sq in)	SP150	<ul style="list-style-type: none"> ● Outer sill reinforcement ● Main back pillar

SP130 is the most commonly used HSS.

SP150 HSS is used only on parts that require much more strength.

Read the following precautions when repairing HSS:

1. Additional points to consider

- The repair of reinforcements (such as side members) by heating is not recommended since it may weaken the component. When heating is unavoidable, do not heat HSS parts above 550°C (1,022°F). Verify heating temperature with a thermometer. (Crayon-type and other similar type thermometer are appropriate.)

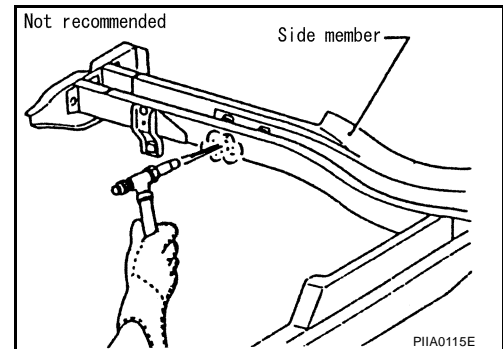

- When straightening body panels, use caution in pulling any HSS panel. Because HSS is very strong, pulling may cause deformation in adjacent portions of the body. In this case, increase the number of measuring points, and carefully pull the HSS panel.

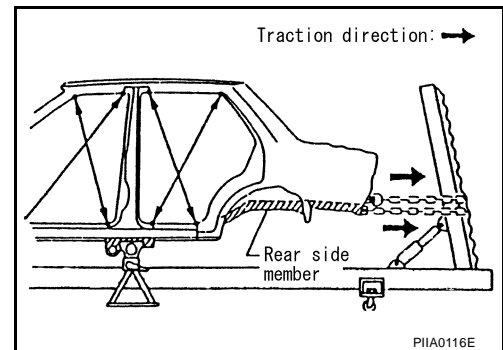

- When cutting HSS panels, avoid gas (torch) cutting if possible. Instead, use a saw to avoid weakening surrounding areas due to heat. If gas (torch) cutting is unavoidable, allow a minimum margin of 50 mm (1.97in).

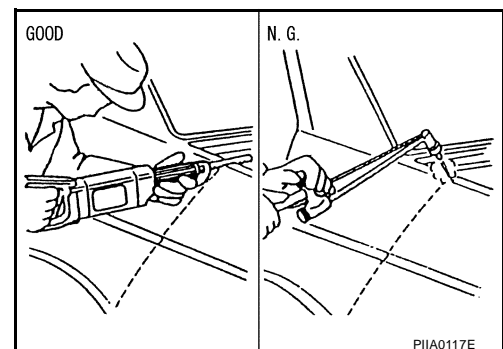

BODY REPAIR

- When welding HSS panels, use spot welding whenever possible in order to minimize weakening surrounding areas due to heat.
If spot welding is impossible, use M.I.G. welding. Do not use gas (torch) welding because it is inferior in welding strength.

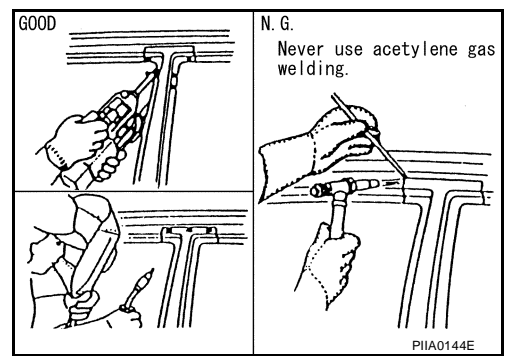

- The spot weld on HSS panels is harder than that of an ordinary steel panel.
Therefore, when cutting spot welds on a HSS panel, use a low speed high torque drill (1,000 to 1,200 rpm) to increase drill bit durability and facilitate the operation.
- SP150 HSS panels with a tensile strength of 785 to 981 N/mm² (80 to 100 kg/mm², 114 to 142 klb/sq in), used as reinforcement in the door guard beams, is too strong to repair.
When these HSS parts are damaged, the outer panels also sustain substantial damage; therefore, the assembly parts must be replaced.

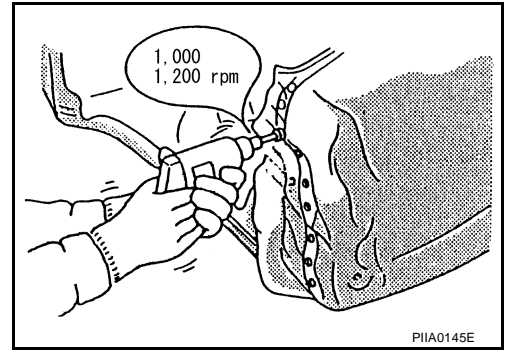

2. Precautions in spot welding HSS

This work should be performed under standard working conditions. Always note the following when spot welding HSS:

- The electrode tip diameter must be sized properly according to the metal thickness.

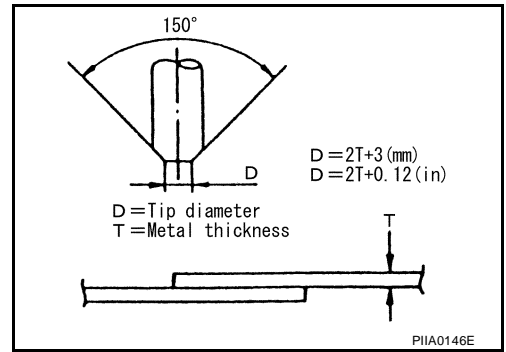

- The panel surfaces must fit flush to each other, leaving no gaps.

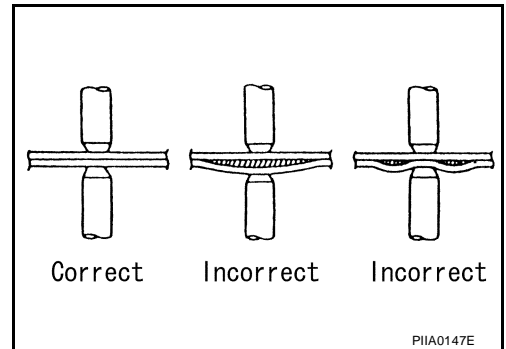

BODY REPAIR

- Follow the specifications for the proper welding pitch.

Thickness (t)	Minimum pitch (ℓ)
0.6 (0.024)	10 (0.39) or over
0.8 (0.031)	12 (0.47) or over
1.0 (0.039)	18 (0.71) or over
1.2 (0.047)	20 (0.79) or over
1.6 (0.063)	27 (1.06) or over
1.8 (0.071)	31 (1.22) or over

Unit:mm

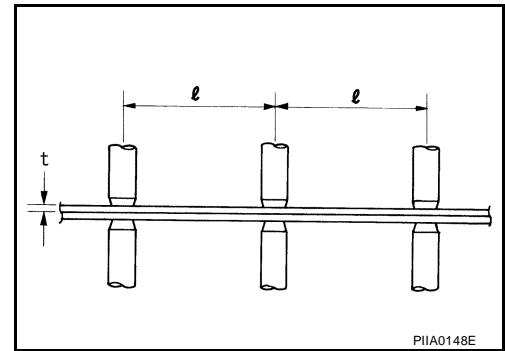

PIIA0148E

EIS008SN

Foam Repair

During factory body assembly, foam insulators are installed in certain body panels and locations around the vehicle. Use the following procedure(s) to replace any factory-installed foam insulators.

URETHANE FOAM APPLICATIONS

Use commercially available spray foam for sealant (foam material) repair of material used on vehicle. Read instructions on product for fill procedures.

FILL PROCEDURES

1. Fill procedures after installation of service part.
 - Remove foam material remaining on vehicle side.
 - Clean area in which foam was removed.
 - Install service part.
 - Insert nozzle into hole near fill area and fill foam material or fill in enough to close gap with the service part.

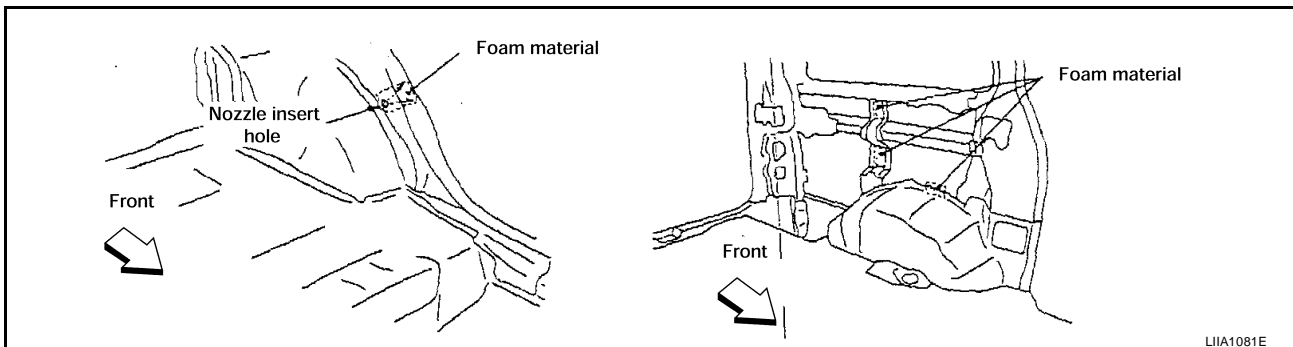

LIA1081E

2. Fill procedures before installation of service part.
 - Remove foam material remaining on vehicle side.
 - Clean area in which foam was removed.
 - Fill foam material on wheelhouse outer side.

NOTE:

Fill in enough to close gap with service part while avoiding flange area.

- Install service part.

NOTE:

Refer to label for information on working times.

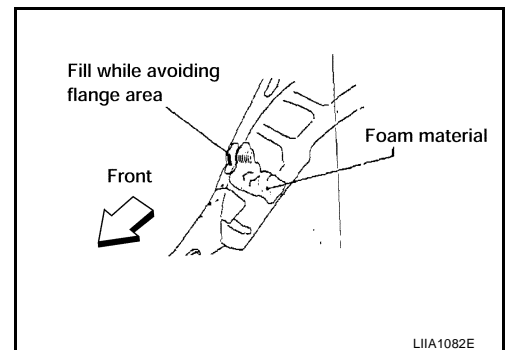

LIA1082E

BODY REPAIR

Replacement Operations

EIS00850

DESCRIPTION

This section is prepared for technicians who have attained a high level of skill and experience in repairing collision-damaged vehicles and also use modern service tools and equipment. Persons unfamiliar with body repair techniques should not attempt to repair collision-damaged vehicles by using this section.

Technicians are also encouraged to read Body Repair Manual (Fundamentals) in order to ensure that the original functions and quality of the vehicle can be maintained. The Body Repair Manual (Fundamentals) contains additional information, including cautions and warnings, that are not including in this manual. Technicians should refer to both manuals to ensure proper repairs.







Please note that this information is prepared for worldwide usage, and as such, certain procedures may not apply in some regions or countries.

A
B
C
D
E
F
G
H
J
K
L
M

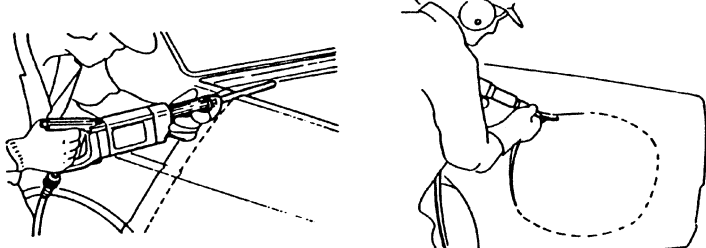
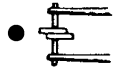
BL

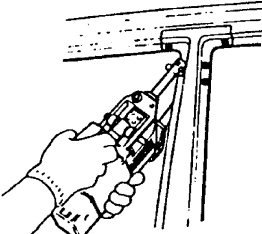
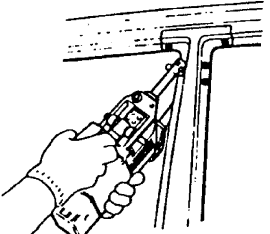
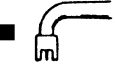
BODY REPAIR

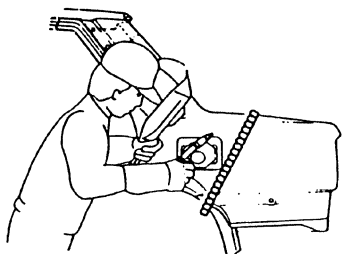
The symbols used in this section for cutting and welding / brazing operations are shown below.

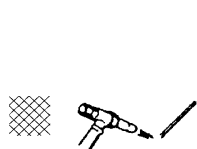
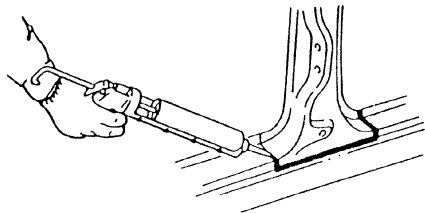
 Saw cut or air chisel cut	
<p>Spot weld</p> <p>● ● ● ● 2-spot welds</p>  <p>● ● ● ● 3-spot welds</p> 	<p>2-spot welds (2-panel overlapping portions)</p>  <p>3-spot welds (3-panel overlapping portions)</p> 
<p>■ ■ ■ ■ MIG plug weld</p> 	
<p>~~~~~ MIG seam weld/ Point weld</p> 	
<p>▨ ▨ ▨ ▨ Brazing</p> 	
<p>▩ ▩ ▩ ▩ Soldering</p> 	
<p>————— Sealing</p>	

BODY REPAIR

- Front pillar butt joint can be determined anywhere within shaded area as shown in the figure. The best location for the butt joint is at position A due to the construction of the vehicle. Refer to the front pillar section.

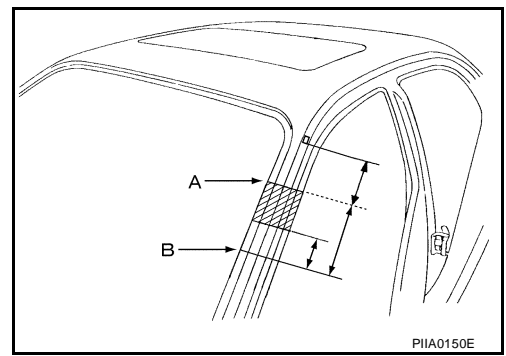

- Determine cutting position and record distance from the locating indent. Use this distance when cutting the service part. Cut outer front pillar over 60 mm above inner front pillar cut position.

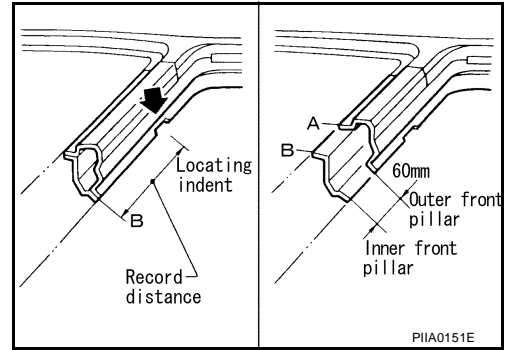

- Prepare a cutting jig to make outer pillar easier to cut. Also, this will permit service part to be accurately cut at joint position.

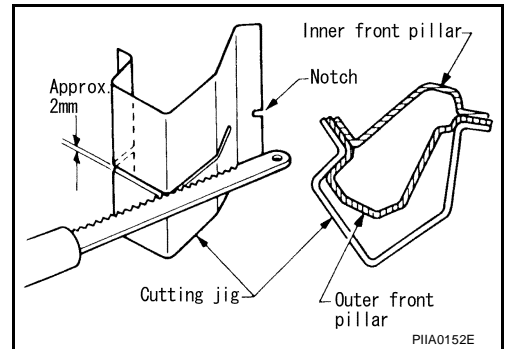

- An example of cutting operation using a cutting jig is as follows.

1. Mark cutting lines.
A: Cut position of outer pillar
B: Cut position of inner pillar
2. Align cutting line with notch on jig. Clamp jig to pillar.
3. Cut outer pillar along groove of jig. (At position A)
4. Remove jig and cut remaining portions.
5. Cut inner pillar at position B in same manner.

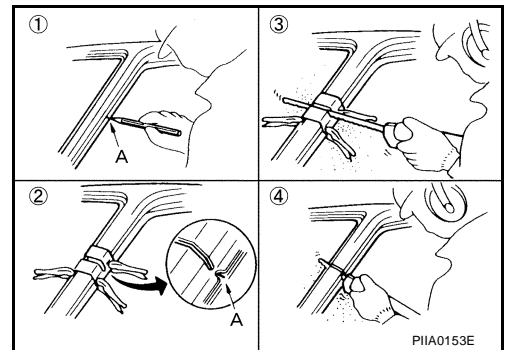

A
B
C
D
E
F
G
H
BL
J
K
L
M

BODY REPAIR

HOODLEDGE

- Work after radiator core support has been removed.

Service Joint

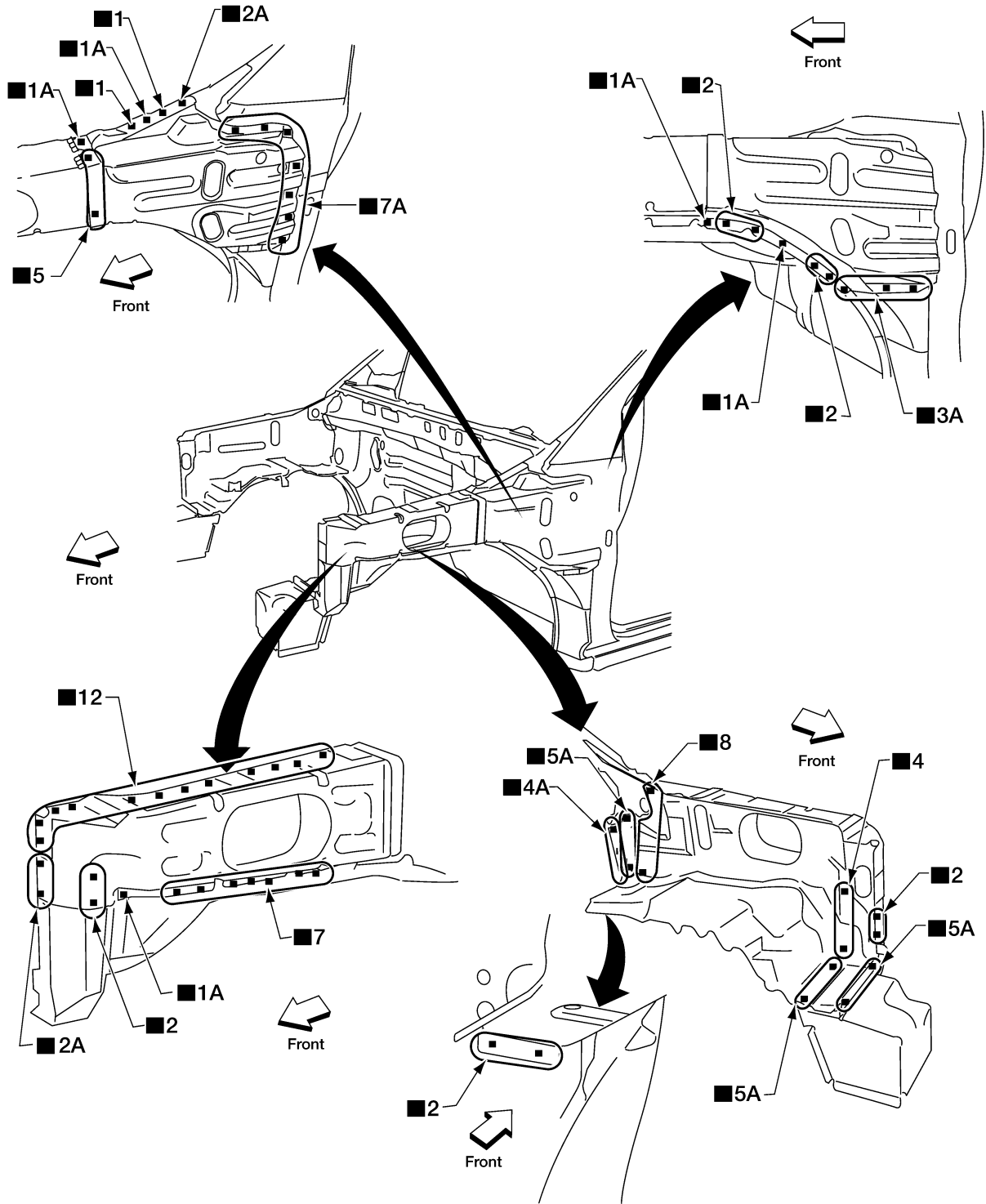

2-spot welds

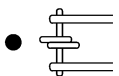

3-spot welds

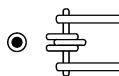

MIG Plug weld

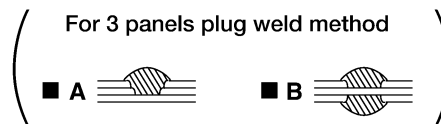
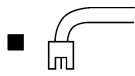

MIG seam weld/
Point weld



LIA1154E

BODY REPAIR

FRONT PILLAR

- Work after rear hoodedge reinforcement has been removed.

Service Joint

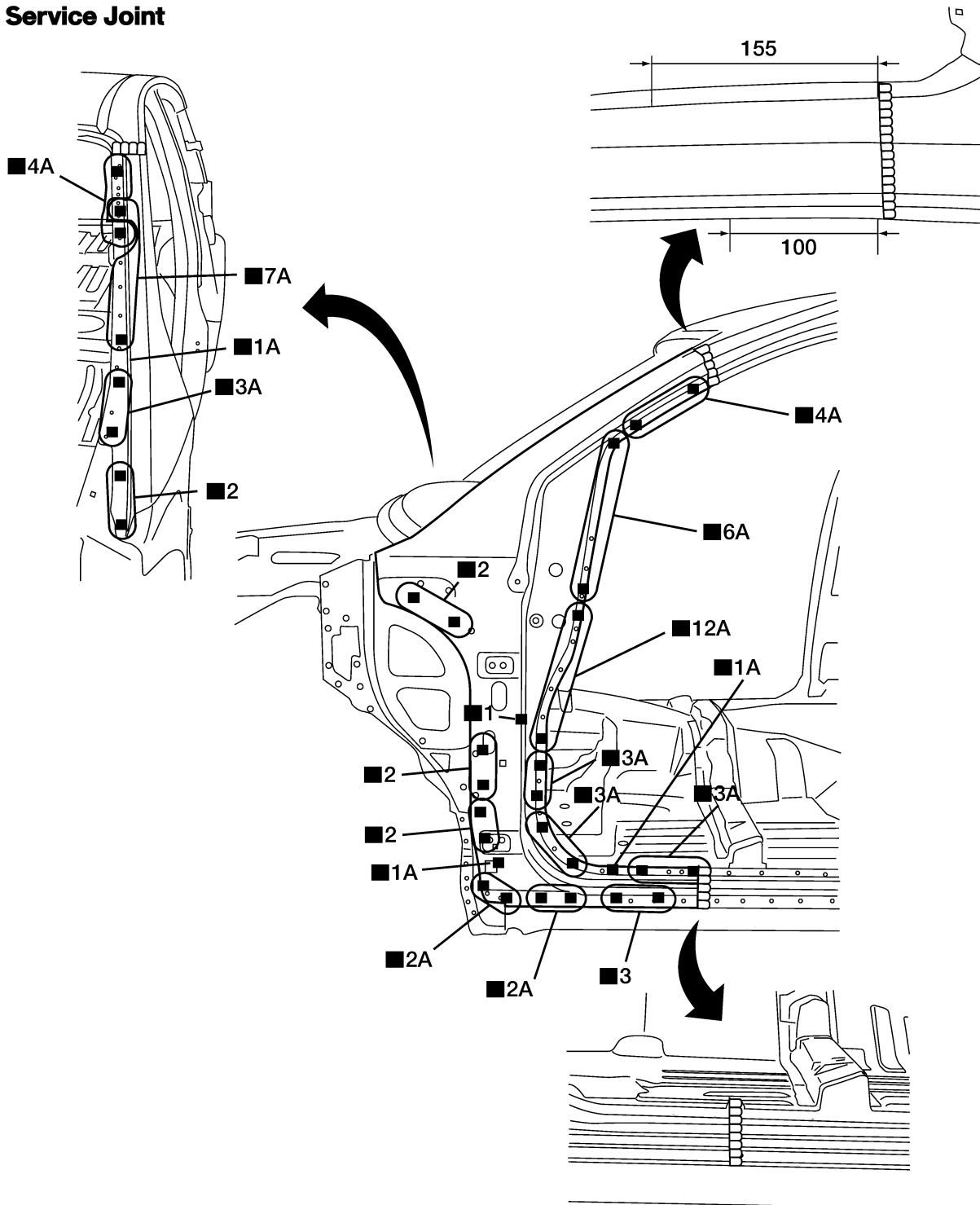

Unit : mm

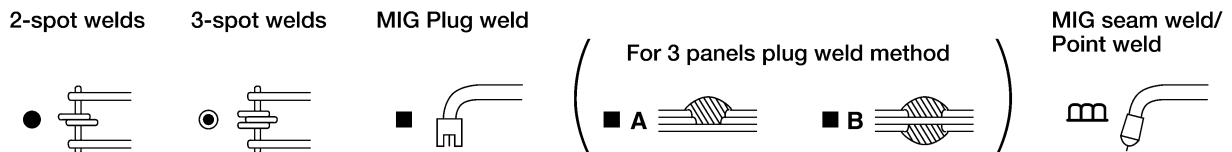

LIA1108E

BODY REPAIR

Service Joint

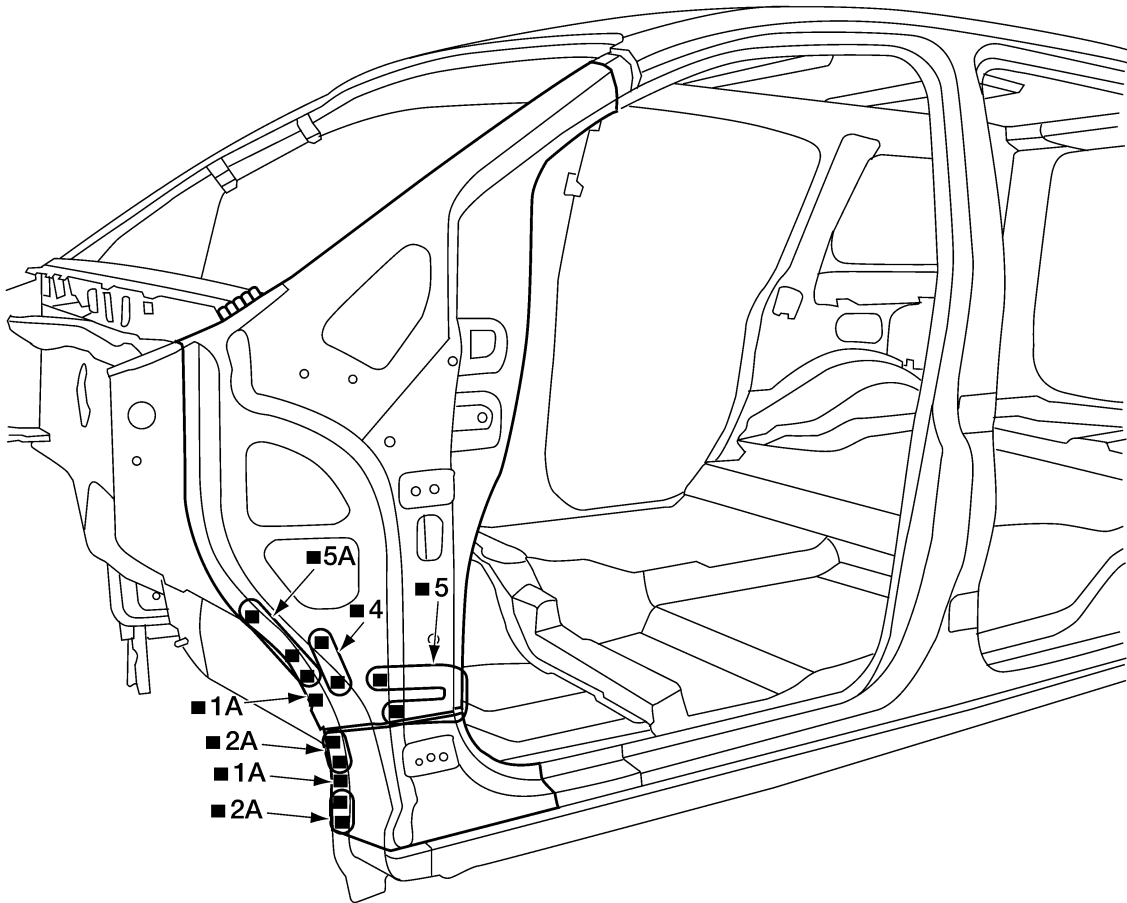

Unit : mm

2-spot welds

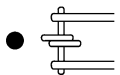

3-spot welds

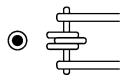

MIG Plug weld

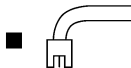

For 3 panels plug weld method

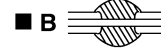

MIG seam weld/
Point weld



LIA1109E

BODY REPAIR

Service Joint

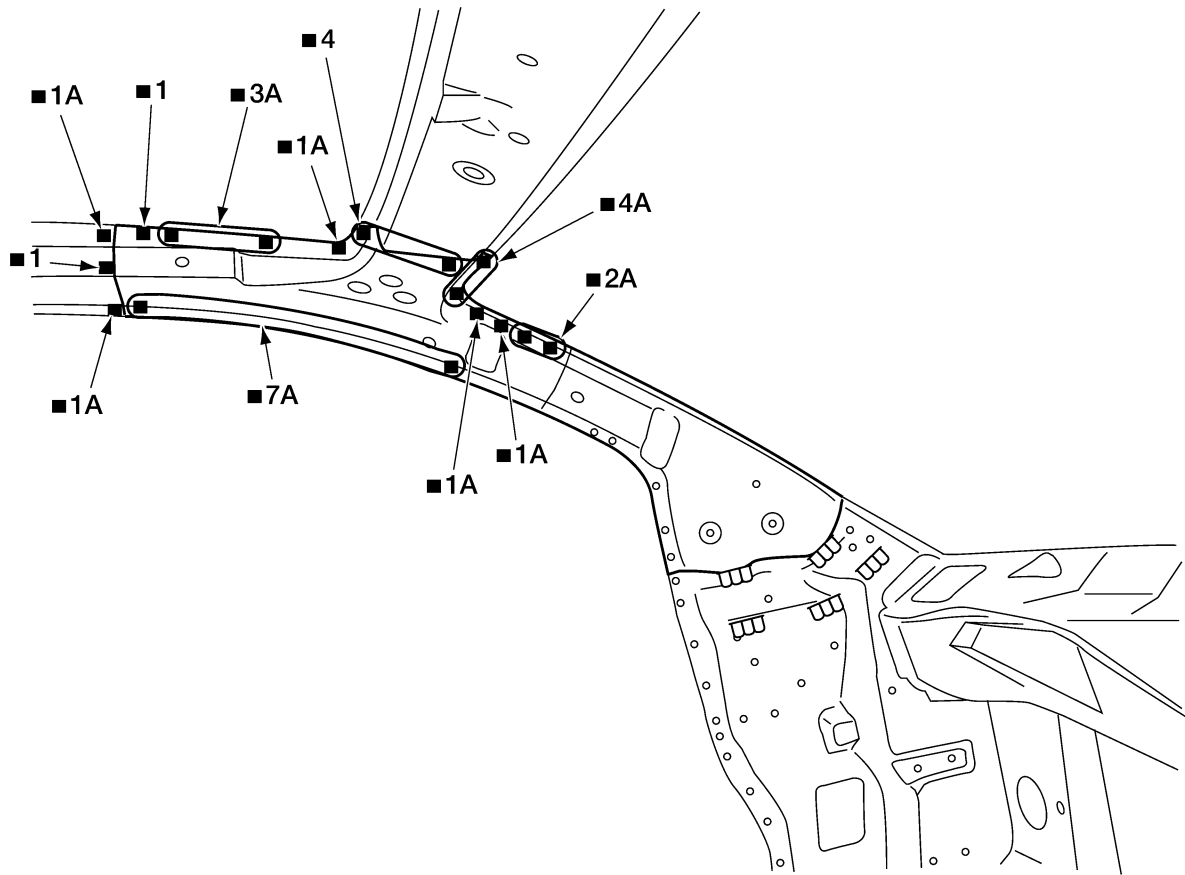

A
B
C
D
E
F
G
H
BL
J
K
L
M

Unit : mm

2-spot welds

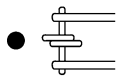

3-spot welds

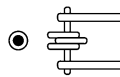

MIG Plug weld

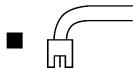

For 3 panels plug weld method



MIG seam weld/
Point weld



LIIA1110E

BODY REPAIR

CENTER PILLAR

Service Joint

* Reinforcement is retained with the same welds as the b-pillar outer sheet metal.

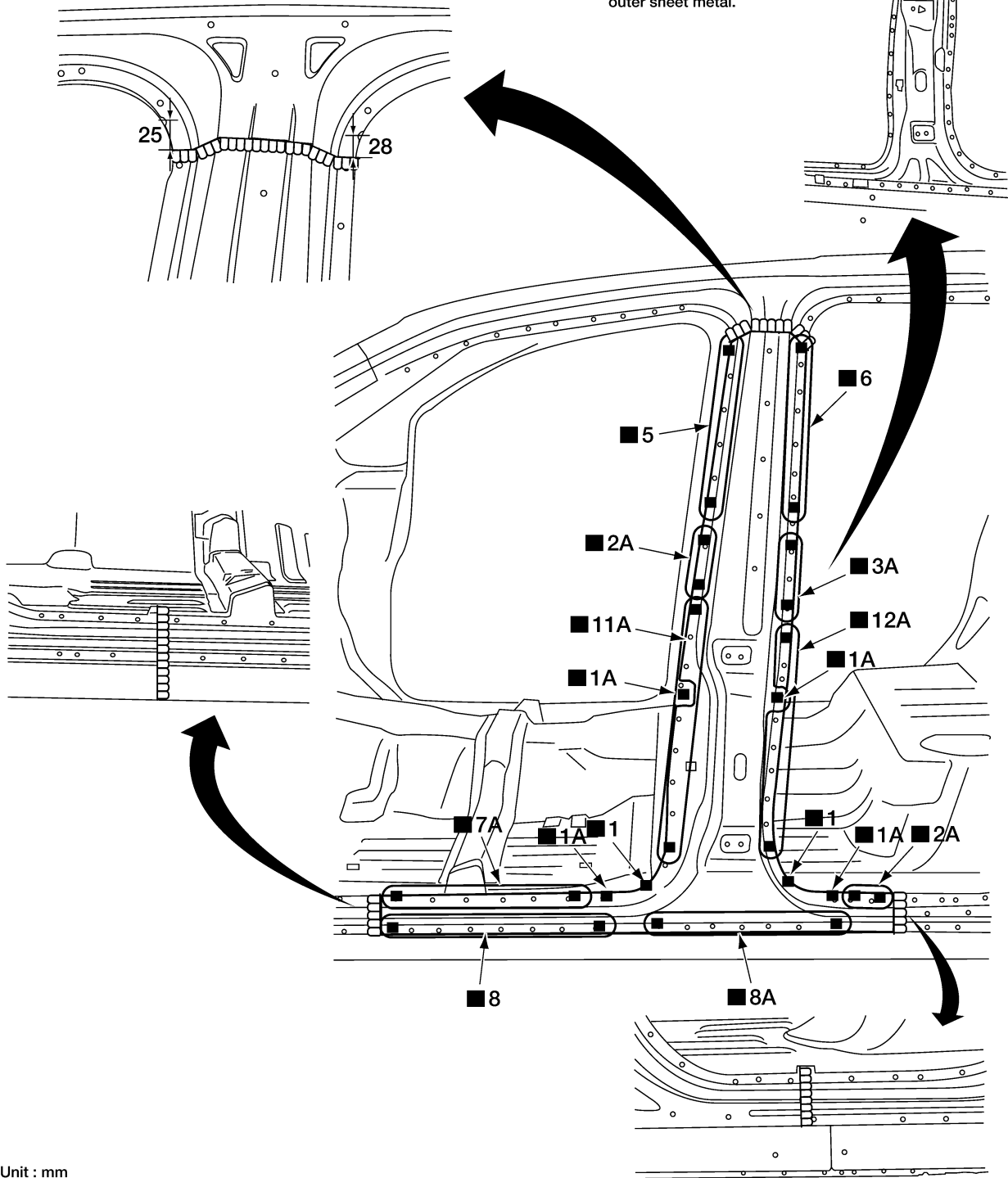

Unit : mm

2-spot welds

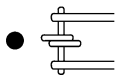

3-spot welds

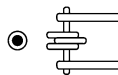

MIG Plug weld

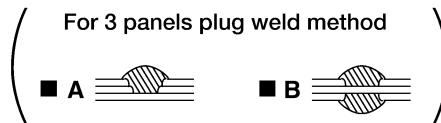
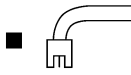

MIG seam weld/
Point weld



LIA1111E

BODY REPAIR

Service Joint

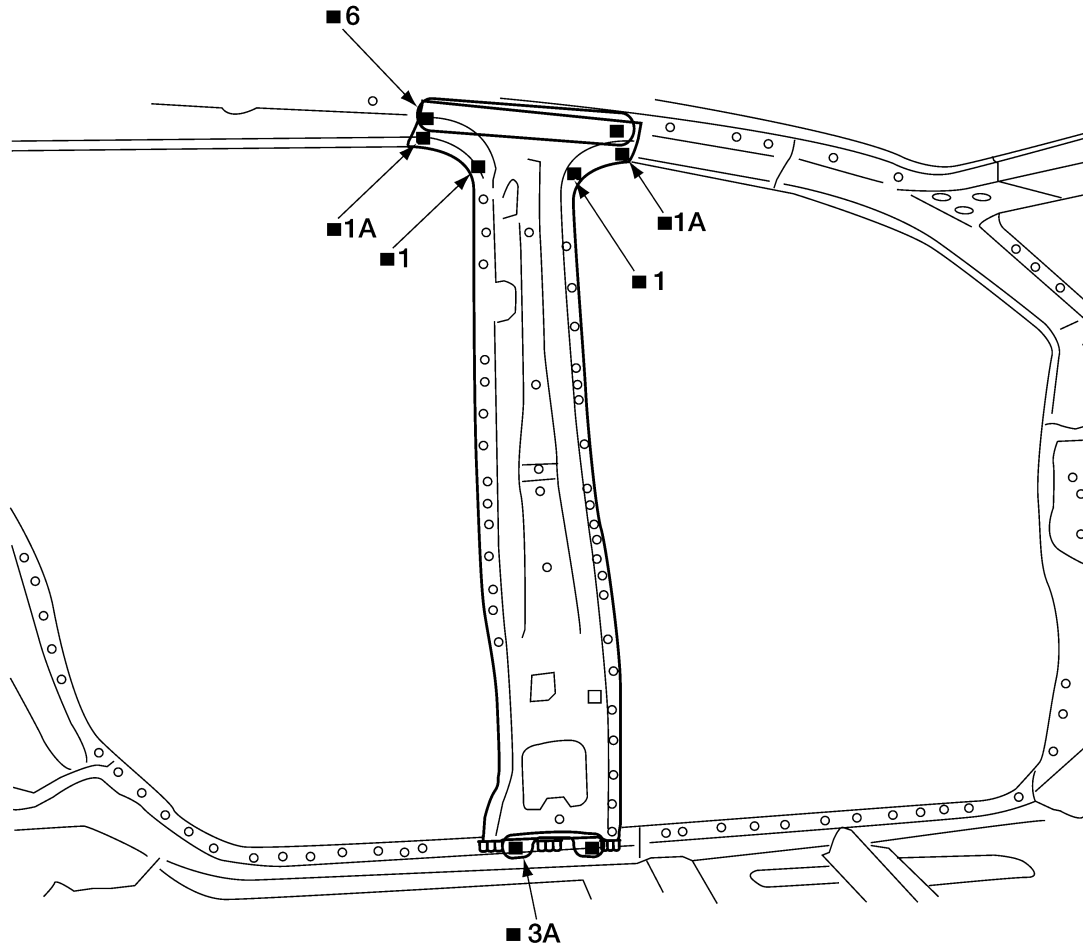

A
B
C
D
E
F
G
H
BL
J
K
L
M

Unit : mm

2-spot welds

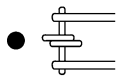

3-spot welds

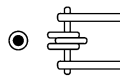

MIG Plug weld

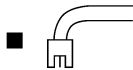

For 3 panels plug weld method

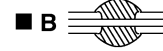

MIG seam weld/
Point weld



LIA1112E

BODY REPAIR

OUTER SILL

Service Joint

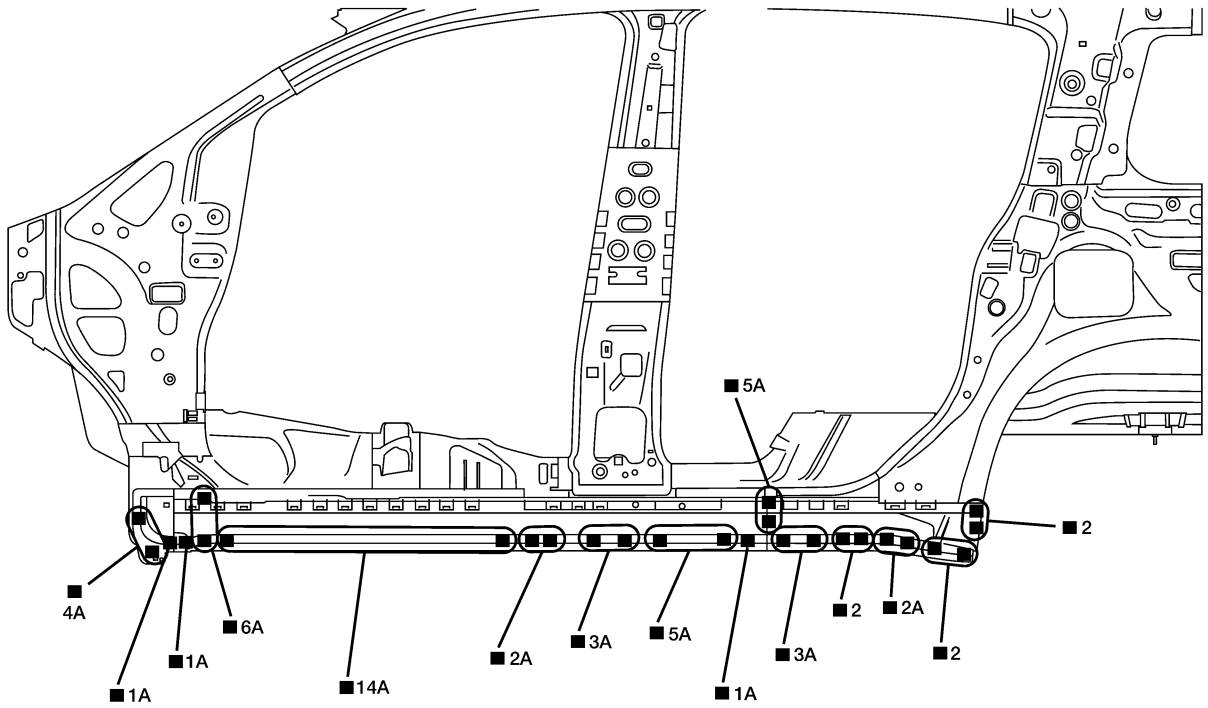

2-spot welds

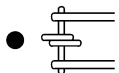

3-spot welds

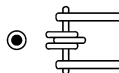

MIG Plug weld

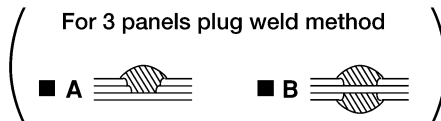
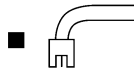

MIG seam weld/
Point weld



LIA1118E

BODY REPAIR

REAR FENDER

Service Joint

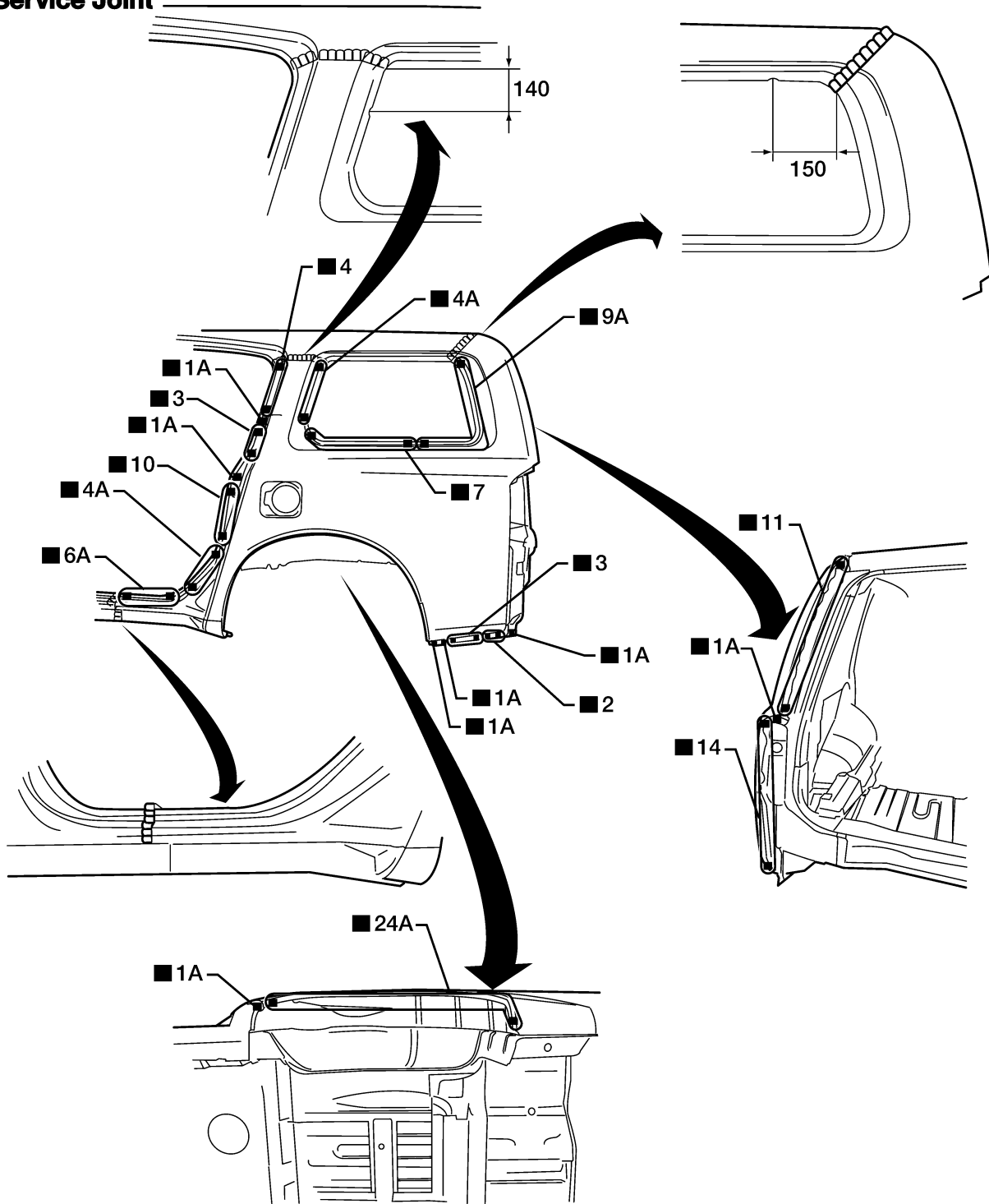

A
B
C
D
E
F
G
H
BL
J
K
L
M

2-spot welds



3-spot welds

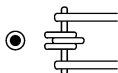

MIG Plug weld

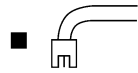

(For 3 panels plug weld method)



MIG seam weld/
Point weld



WHIA0285E

BODY REPAIR

Service Joint

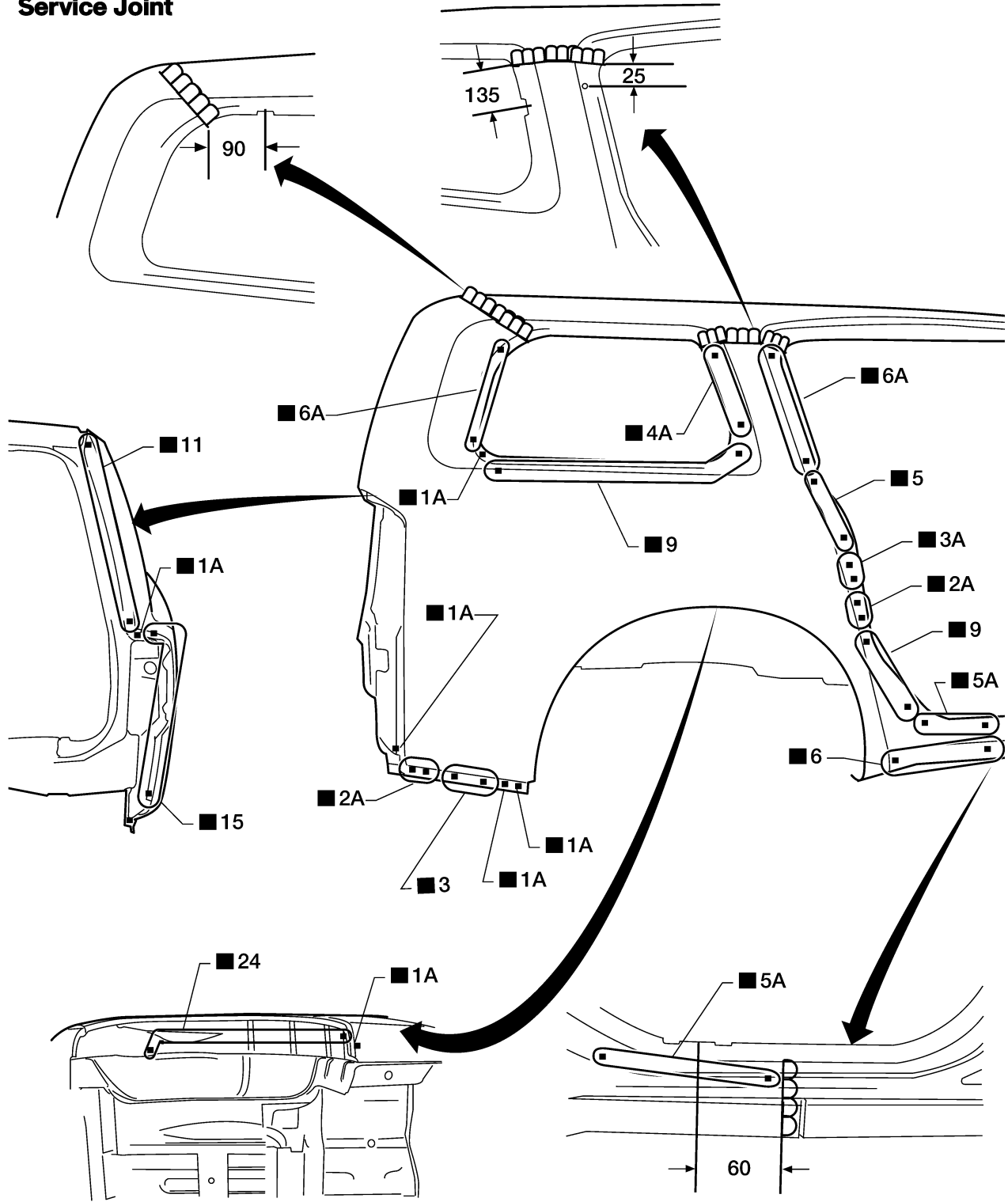

2-spot welds

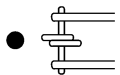

3-spot welds

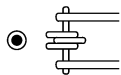

MIG Plug weld

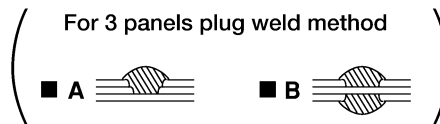
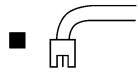

MIG seam weld/
Point weld



WI1A0283E

BODY REPAIR

REAR SIDE MEMBER

Service Joint

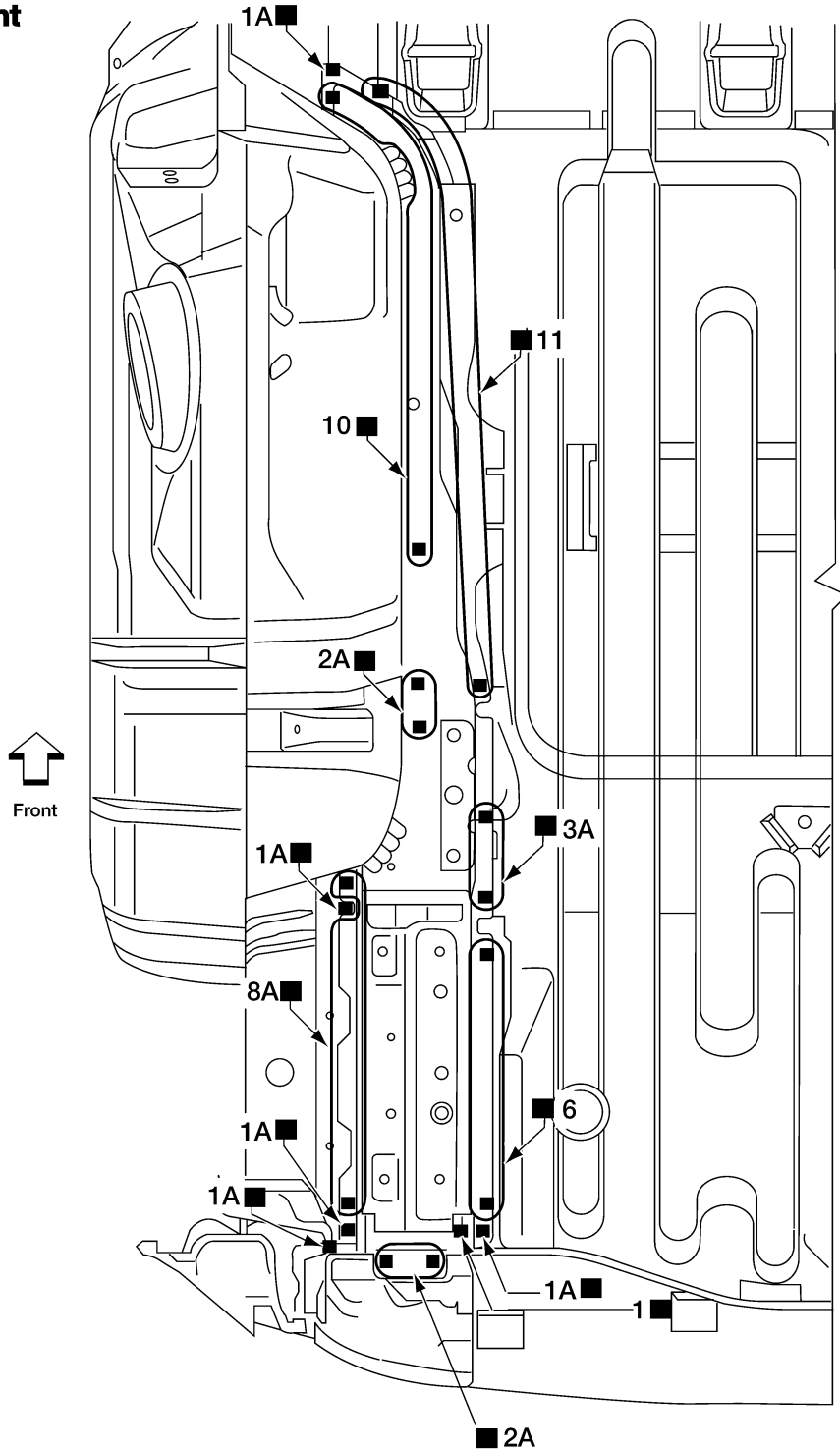

2-spot welds

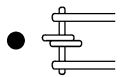

3-spot welds

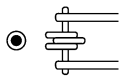

MIG Plug weld

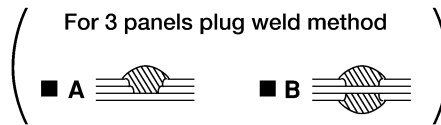
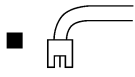

MIG seam weld/
Point weld



WHIA0281E

BODY REPAIR

REAR FLOOR REAR

Service Joint

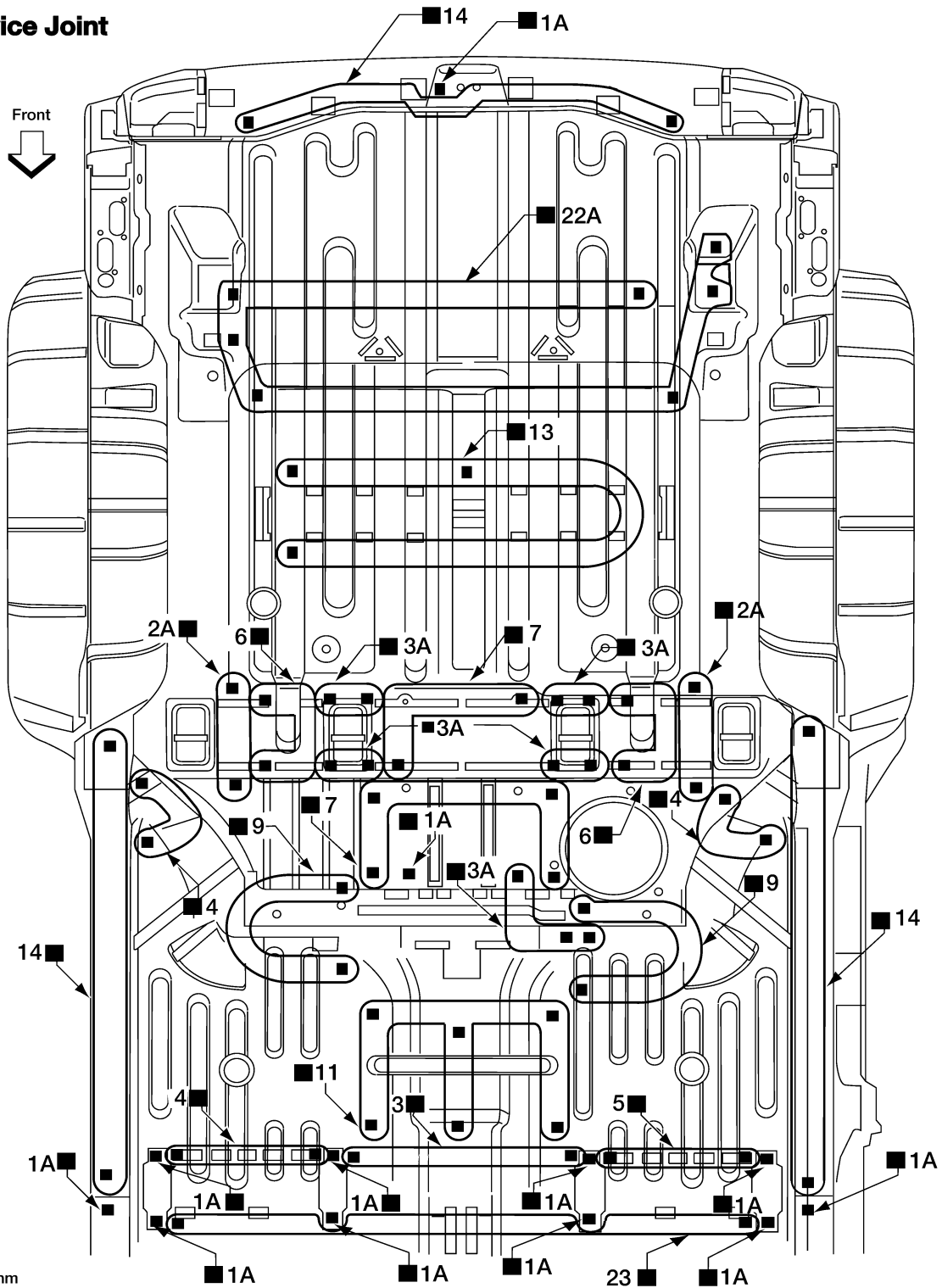

Unit : mm

2-spot welds

3-spot welds

MIG Plug weld

(For 3 panels plug weld method)

MIG seam weld/
Point weld

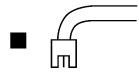
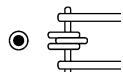
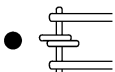

WIIA0282E

BODY REPAIR

CRUSH HORN

- Work after 1st crossmember has been removed.

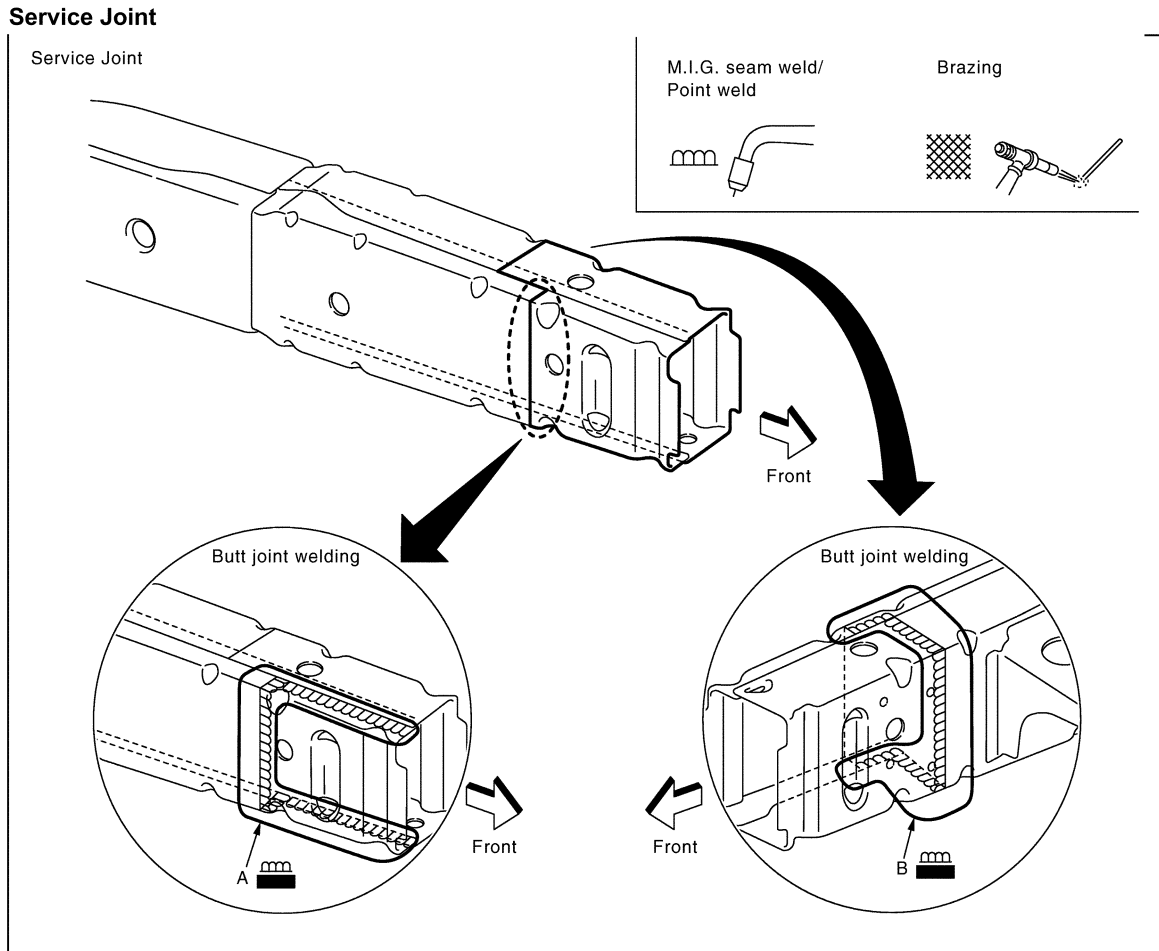

LIA1083E

Portions to be welded:

- A. Inner side rail crush horn, inner side rail crush horn and outer side rail crush horn.
- B. Outer side rail crush horn, outer side rail crush horn and inner side rail crush horn.

A
B
C
D
E
F
G
H
BL
J
K
L
M

BODY REPAIR

Removal Notes

- Scribe a straight line on the outer side rail crush horn and inner side rail crush horn along the hole center as shown in the figure.

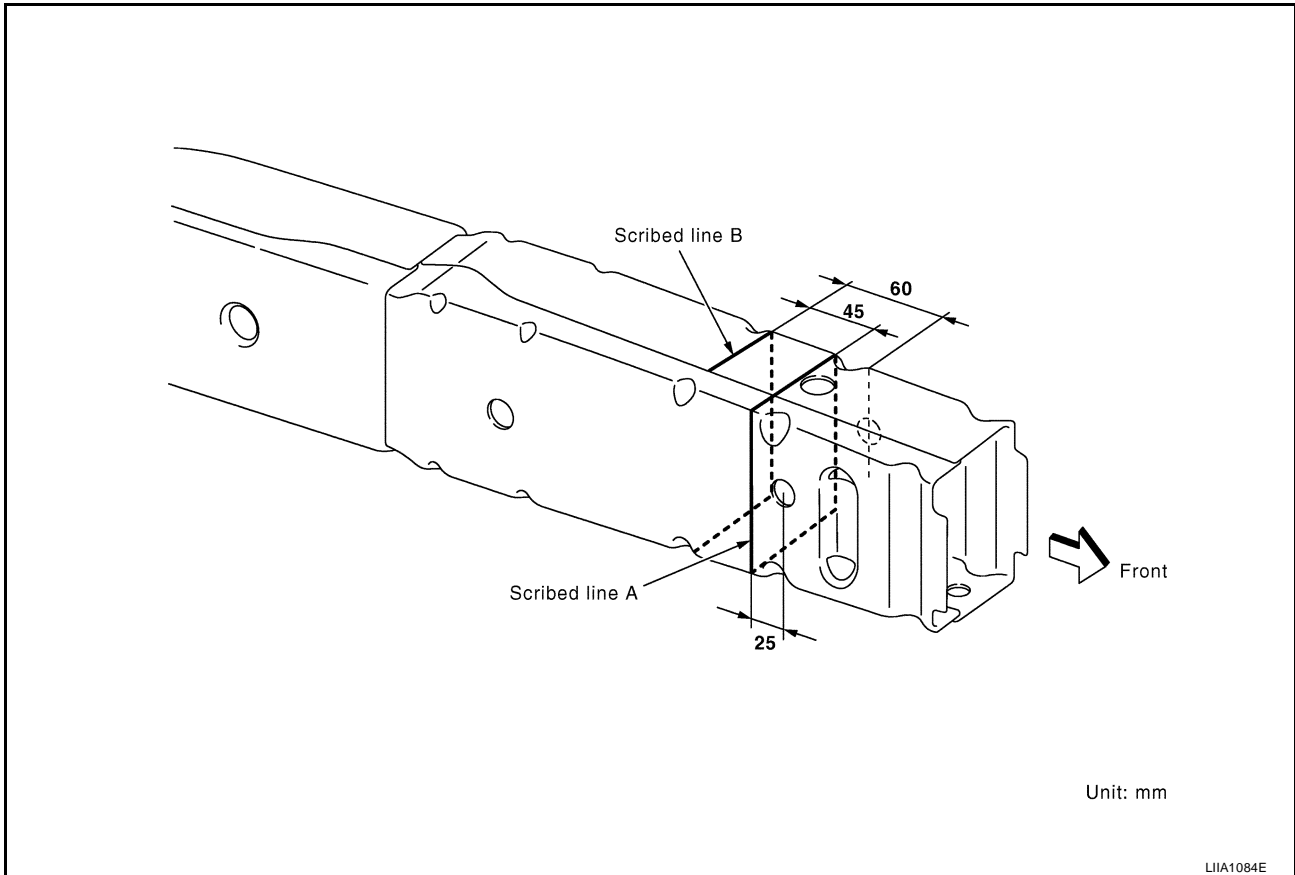

- Cut off outer side rail crush horn and inner side rail crush horn along scribed line A. Do not cut on the hole.

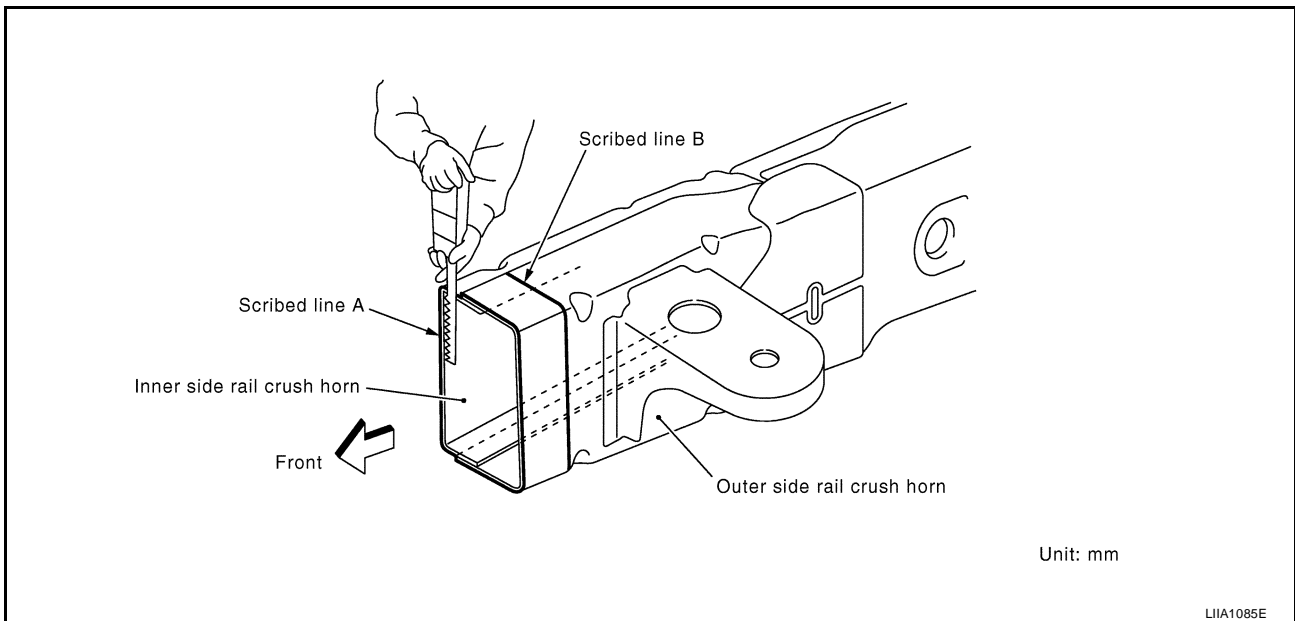

- Cut inner side rail crush horn at 45 mm backward cut position of cut line A. (along line B)

BODY REPAIR

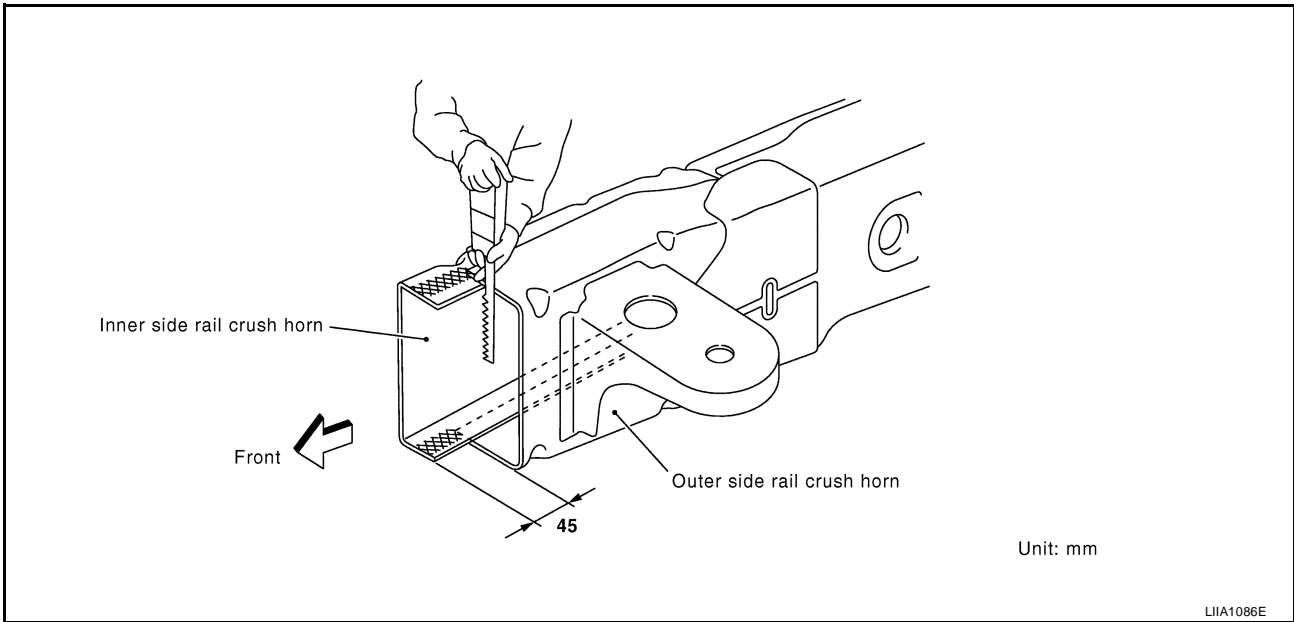

- After removing outer panel, dress area on the inner panel surface with a sander or equivalent.

A
B
C
D
E
F
G
H
BL
J
K
L
M

BODY REPAIR

Installation Notes

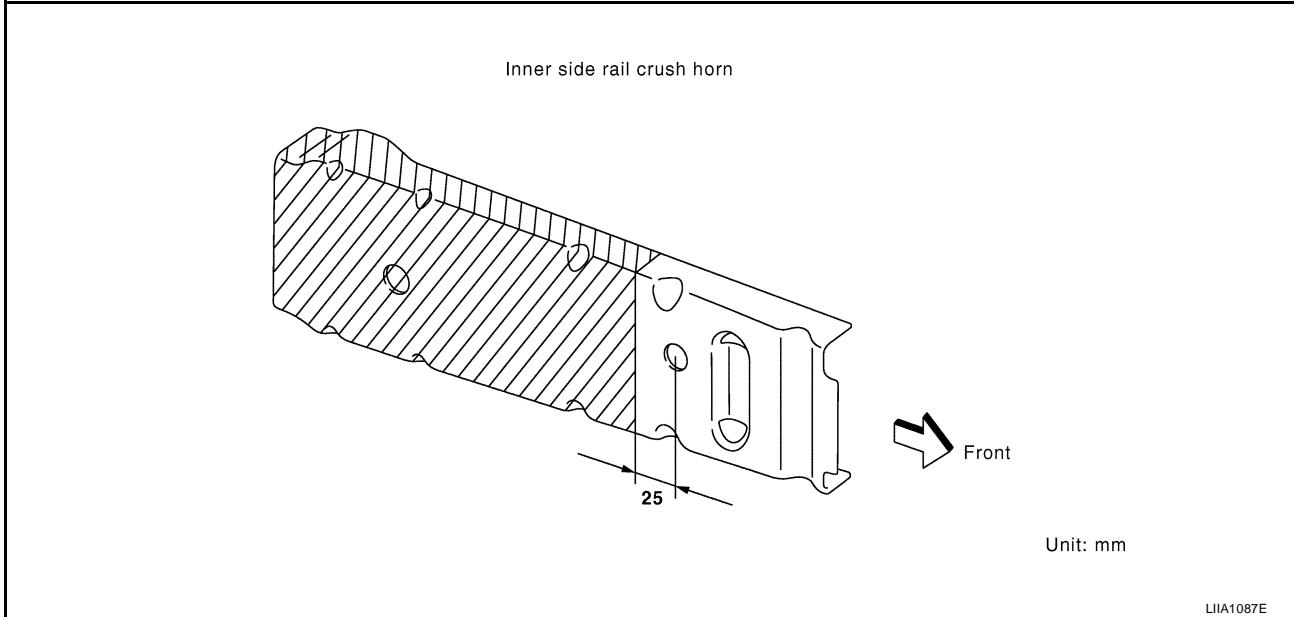

- Scribe a straight line on the inner side rail crush horn along the hole center as shown in the figure. Cut off inner side rail crush horn along scribed line.

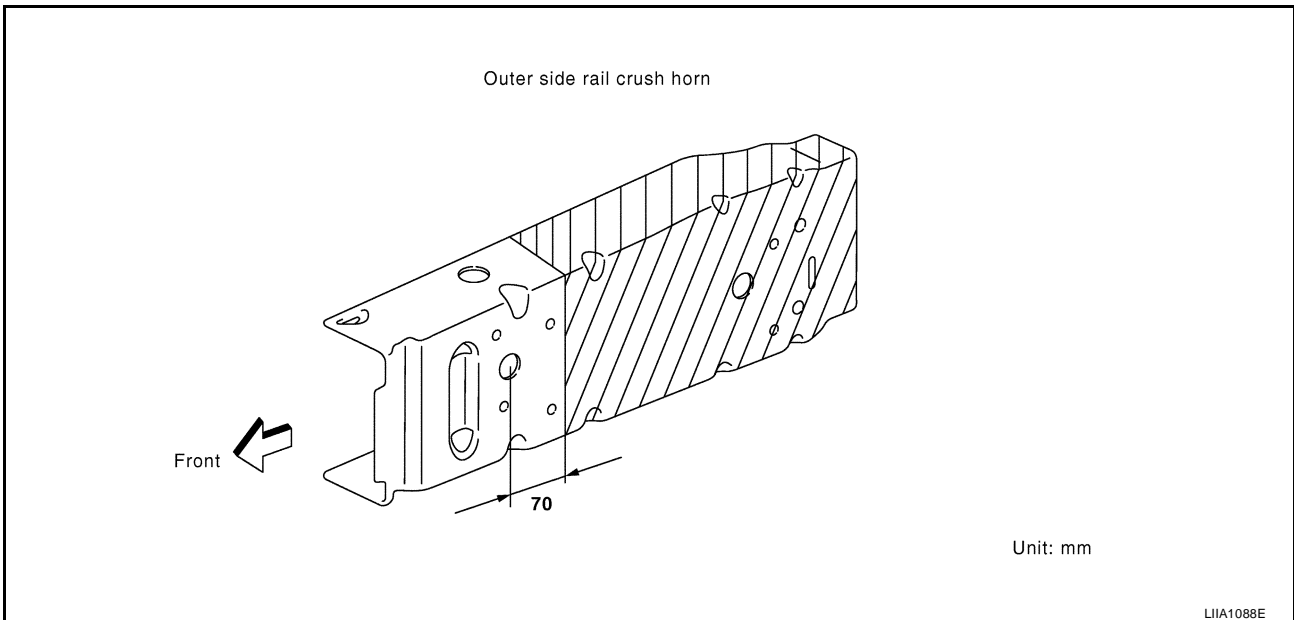

- Scribe a straight line on the outer side rail crush horn along the hole center as shown in the figure. Cut off outer side rail crush horn along scribed line.

BODY REPAIR

- Weld part to be butt-welded and seam-welded corner to corner as shown in the figure.

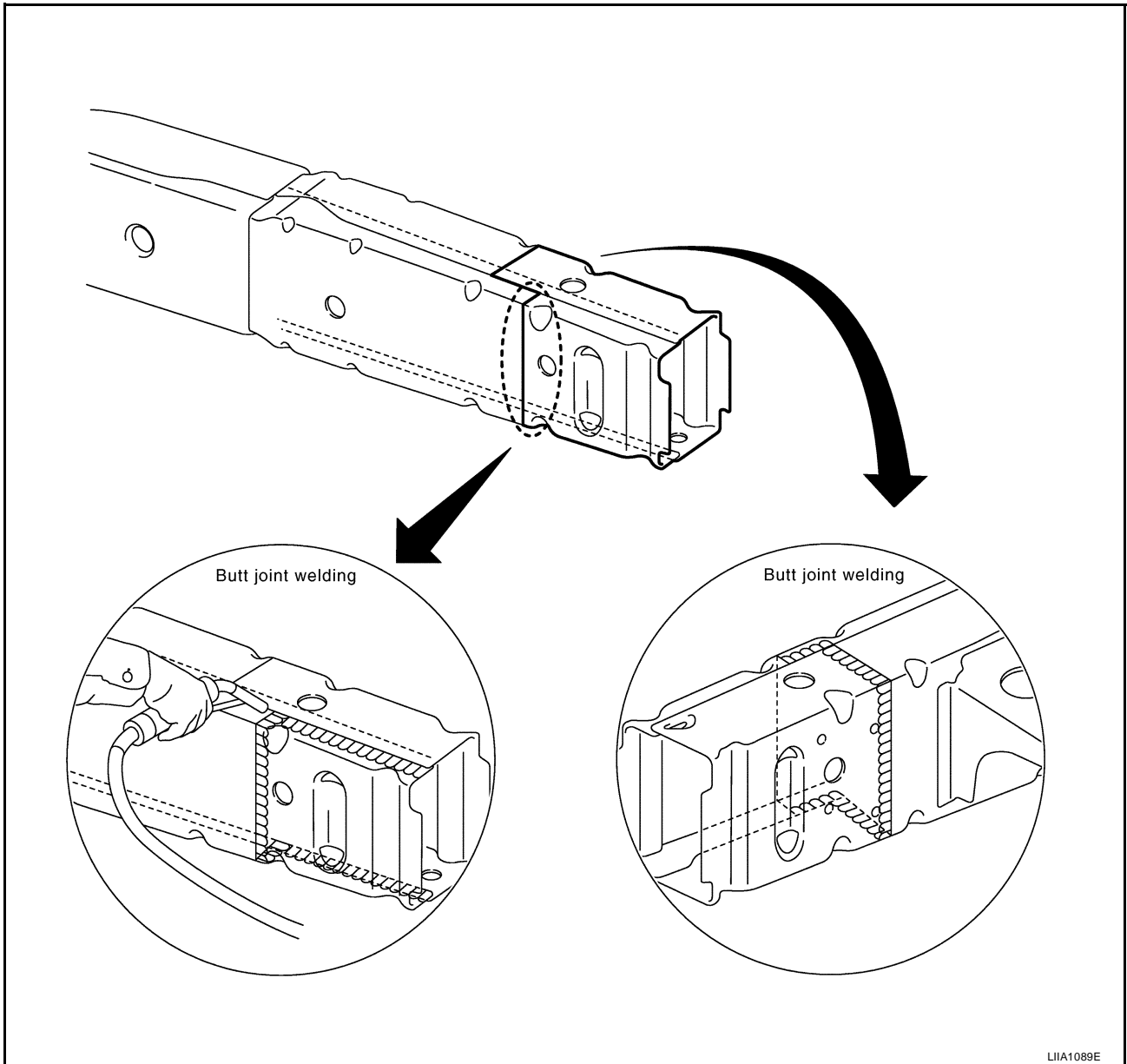

BODY REPAIR
