

SECTION **FSU**
FRONT SUSPENSION

A
B
C
D

FSU

CONTENTS

PRECAUTIONS	2	STABILIZER BAR	12	F
Precautions	2	Removal and Installation	12	
PREPARATION	3	REMOVAL	12	
Special Service Tools	3	INSPECTION AFTER REMOVAL	12	G
Commercial Service Tools	3	INSTALLATION	12	
NOISE, VIBRATION, AND HARSHNESS (NVH)		UPPER LINK	13	H
TROUBLESHOOTING	4	Removal and Installation	13	
NVH Troubleshooting Chart	4	REMOVAL	13	
FRONT SUSPENSION ASSEMBLY	5	INSPECTION AFTER REMOVAL	13	
Components	5	INSTALLATION	13	I
ON-VEHICLE SERVICE	6	LOWER LINK	14	
Front Suspension Parts	6	Removal and Installation	14	
Front Wheel Alignment	6	REMOVAL	14	
PRELIMINARY INSPECTION	6	INSPECTION AFTER REMOVAL	14	J
GENERAL INFORMATION AND RECOMMEN-		INSTALLATION	14	
DATIONS	6	UPPER BALL JOINT AND LOWER BALL JOINT...	15	K
THE ALIGNMENT PROCESS	7	Removal and Installation	15	
CAMBER AND CASTER	7	Inspection	15	
TOE-IN	7	SWINGING FORCE	15	
FRONT WHEEL TURNING ANGLE	8	TURNING FORCE	15	
COIL SPRING AND SHOCK ABSORBER	10	VERTICAL END PLAY	16	L
Removal and Installation	10	KNUCKLE	17	
REMOVAL	10	On-Vehicle Inspection and Service	17	
INSTALLATION	10	Removal and Installation	17	M
Disassembly and Assembly	10	REMOVAL	17	
DISASSEMBLY	10	INSPECTION AFTER REMOVAL	18	
INSPECTION AFTER DISASSEMBLY	10	INSTALLATION	19	
ASSEMBLY	11	SERVICE DATA AND SPECIFICATIONS (SDS)	20	
		General Specifications (Front)	20	
		Wheel Alignment (Unladen*1)*6	20	
		Ball Joint	21	
		Wheelarch Height (Unladen*1)	21	

PRECAUTIONS

PRECAUTIONS

PF0:00001

Precautions

EES001GD

- When installing the rubber bushings, the final tightening must be done under unladen condition and with the tires on level ground. Oil will shorten the life of the rubber bushings, so wipe off any spilled oil immediately.
- Unladen condition means the fuel tank, engine coolant and lubricants are at the full specification. The spare tire, jack, hand tools, and mats are in their designated positions.
- After installing suspension components, check the wheel alignment.
- Lock nuts are not reusable. Always use new lock nuts for installation. New lock nuts are pre-oiled, do not apply any additional lubrication.

PREPARATION

PREPARATION

PFP:00002

Special Service Tools

EES001GE

The actual shapes of Kent-Moore tools may differ from those of special service tools illustrated here.

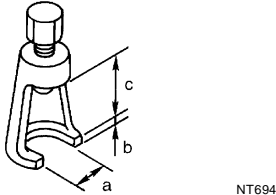
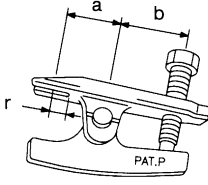
Tool number (Kent-Moore No.) Tool name	Description
ST29020001 (J-24319-01) Gear arm puller	 Removing ball joint for knuckle spindle a: 34 mm (1.34 in) b: 6.5 mm (0.256 in) c: 61.5 mm (2.421 in)
HT72520000 (J-25730-A) Ball joint remover	 Removing tie-rod outer end a: 33 mm (1.30 in) b: 50 mm (1.97 in) r: 11.5 mm (0.453 in)

Commercial Service Tools

EES001GF

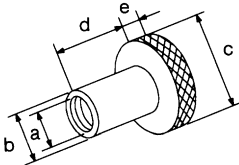
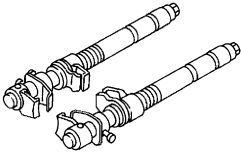
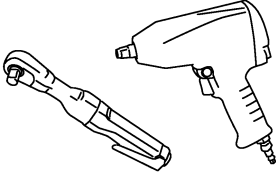
Tool name	Description
Attachment wheel alignment	 Measure wheel alignment a: Screw M24 x 1.5 pitch b: 35 mm (1.38 in) dia. c: 65 mm (2.56 in) dia. d: 56 mm (2.20 in) e: 12 mm (0.47 in)
Spring compressor	 Removing and installing coil spring
Power tool	 Loosening bolts and nuts

NOISE, VIBRATION, AND HARSHNESS (NVH) TROUBLESHOOTING

NOISE, VIBRATION, AND HARSHNESS (NVH) TROUBLESHOOTING

PF0:00003

NVH Troubleshooting Chart

EES001GG

Use the chart below to help you find the cause of the symptom. Repair or replace parts as necessary.

Symptom		Possible Cause and SUSPECTED PARTS										Reference page					
		Improper installation, looseness	Shock absorber deformation, damage or deflection	Bushing or mounting deterioration	Parts interference	Spring fatigue	Suspension looseness	Incorrect wheel alignment	Stabilizer bar fatigue	PROPELLER SHAFT	DIFFERENTIAL	AXLE	TIRES	ROAD WHEEL	BRAKES	STEERING	
Noise	Noise	x	x	x	x	x	x			x	x	x	x	x	x		FSU-5
	Shake	x	x	x	x		x			x		x	x	x	x		FSU-10
	Vibration	x	x	x	x	x				x		x	x				FSU-5
	Shimmy	x	x	x	x			x				x	x	x	x	x	FSU-5
	Shudder	x	x	x								x	x	x	x	x	FSU-21
	Poor quality ride or handling	x	x	x	x	x		x	x			x	x	x			FSU-6 FSU-6 FSU-6
																	PR-3, "NVH Troubleshooting Chart" FFD-6, "NVH Troubleshooting Chart" FAX-4, "NVH Troubleshooting Chart" WT-4, "NVH Troubleshooting Chart" WT-4, "NVH Troubleshooting Chart" BR-5, "NVH Troubleshooting Chart" PS-5, "NVH Troubleshooting Chart"

x: Applicable

FRONT SUSPENSION ASSEMBLY

FRONT SUSPENSION ASSEMBLY

PF5:54010

Components

EES001GH

SEC. 391 • 400 • 401

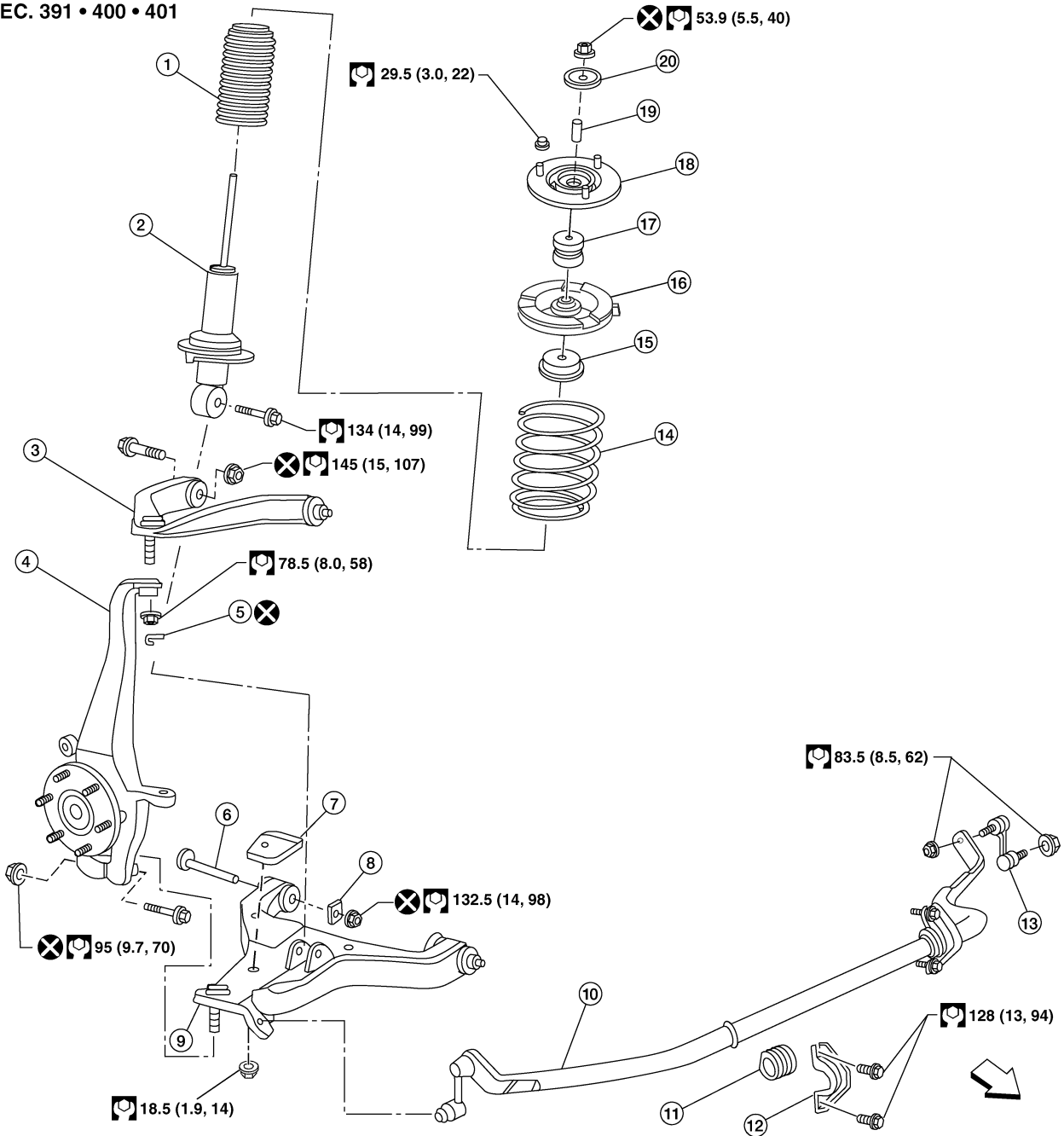

- | | | |
|-----------------------|----------------------------|---------------------------------------|
| 1. Dust cover | 2. Shock absorber | 3. Upper link |
| 4. Steering knuckle | 5. Cotter pin | 6. Bolt |
| 7. Jounce bumper | 8. Washer | 9. Lower link |
| 10. Stabilizer bar | 11. Stabilizer bar bushing | 12. Stabilizer bar mounting bracket |
| 13. Connecting rod | 14. Coil spring | 15. Upper seat |
| 16. Upper spring seat | 17. Shock absorber bushing | 18. Shock absorber mounting insulator |
| 19. Spacer | 20. Washer | ← Front |

WEIA0156E

ON-VEHICLE SERVICE

PF0:0000

Front Suspension Parts

EES001G1

Check front suspension parts for excessive play, cracks, wear and other damage.

- Shake each front wheel to check for excessive play. If looseness is noted, inspect wheel bearing end play, then check ball joint end play. Refer to [FAX-5, "WHEEL BEARING INSPECTION"](#) and [FSU-15, "Inspection"](#).
- Make sure that the cotter pin is inserted (4x4 only).
- Retighten all nuts and bolts to the specified torque.

Suspension component torques : Refer to [FSU-5, "Components"](#).

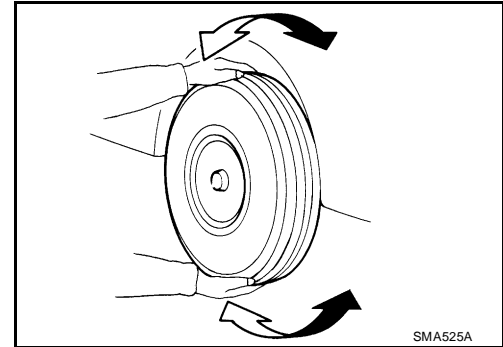

- Check shock absorber for oil leakage and other damage.
- Check suspension ball joint for grease leakage and ball joint dust cover for cracks and other damage.

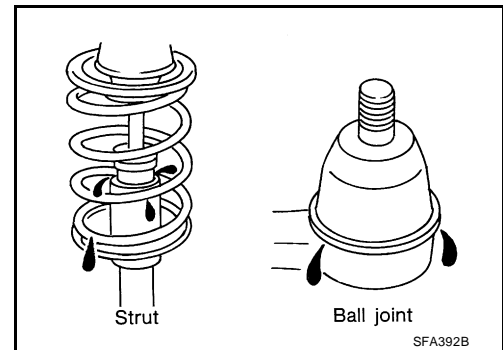

Front Wheel Alignment PRELIMINARY INSPECTION

EES001GJ

WARNING:

Always adjust the alignment with the vehicle on a flat surface.

NOTE:

If alignment is out of specification, inspect and replace any damaged or worn suspension parts before making any adjustments.

1. Check and adjust the wheel alignment with the vehicle under unladen conditions. "Unladen conditions" means that the fuel, coolant, and lubricant are full; and that the spare tire, jack, hand tools and mats are in their designated positions.
2. Check the tires for incorrect air pressure and excessive wear.
3. Check the wheels for run out and damage. Refer to [WT-5, "Inspection"](#).
4. Check the wheel bearing axial end play. Refer to [FAX-5, "WHEEL BEARING INSPECTION"](#).
5. Check the shock absorbers for leaks or damage.
6. Check each mounting point of the suspension components for any excessive looseness or damage.
7. Check each link, arm, and the rear suspension member for any damage.
8. Check the vehicle height. Refer to [FSU-21, "Wheelarch Height \(Unladen*1\)"](#).
 - Verify the level using Consult-II memory register 1103 and set to 0 ± 10 mm (0 ± 0.39 in) as necessary.

GENERAL INFORMATION AND RECOMMENDATIONS

1. A Four-Wheel Thrust Alignment should be performed.
 - This type of alignment is recommended for any NISSAN vehicle.
 - The four-wheel "thrust" process helps ensure that the vehicle is properly aligned and the steering wheel is centered.
 - The alignment machine itself should be capable of accepting any NISSAN vehicle.
 - The alignment machine should be checked to ensure that it is level.
2. Make sure the alignment machine is properly calibrated.
 - Your alignment machine should be regularly calibrated in order to give correct information.

ON-VEHICLE SERVICE

- Check with the manufacturer of your specific alignment machine for their recommended Service/Calibration Schedule.

THE ALIGNMENT PROCESS

IMPORTANT: Use only the alignment specifications listed in this Service Manual. Refer to [FSU-20, "Wheel Alignment \(Unladen^{*1}\)^{*6}"](#).

1. When displaying the alignment settings, many alignment machines use "indicators": (Green/red, plus or minus, Go/No Go). **Do NOT use these indicators.**
 - The alignment specifications programmed into your alignment machine that operate these indicators may not be correct.
 - This may result in an ERROR.
2. Some newer alignment machines are equipped with an optional "Rolling Compensation" method to "compensate" the sensors (alignment targets or head units). **Do NOT use this "Rolling Compensation" method.**
 - Use the "Jacking Compensation" method. After installing the alignment targets or head units, raise the vehicle and rotate the wheels 1/2 turn both ways.
 - See Instructions in the alignment machine you are using for more information.

CAMBER AND CASTER

1. Measure camber and caster of both the right and left wheels with a suitable alignment gauge and adjust as necessary to specification.

Camber and Caster : Refer to [FSU-20, "Wheel Alignment \(Unladen^{*1}\)^{*6}"](#).

NOTE:

Some vehicles may be equipped with straight (non-adjustable) lower link bolts and washers. In order to adjust camber and caster on these vehicles, first replace the lower link bolts and washers with adjustable (cam) bolts and washers.

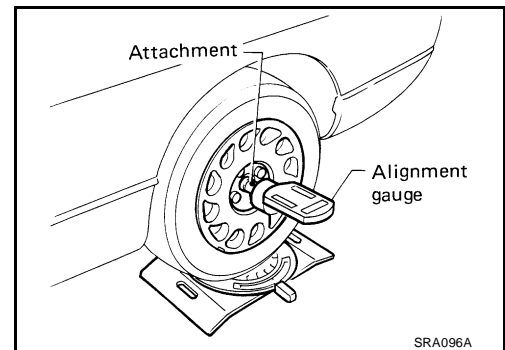

2. If outside of the specified value, adjust camber and caster using the cam bolts (1) in the front lower link (2).

CAUTION:

After adjusting the camber then check the toe-in.

NOTE:

Camber changes about 3' (0.05°) minutes with each graduation of one cam bolt. Refer to table below for examples of lower link cam bolt effect on camber and caster.

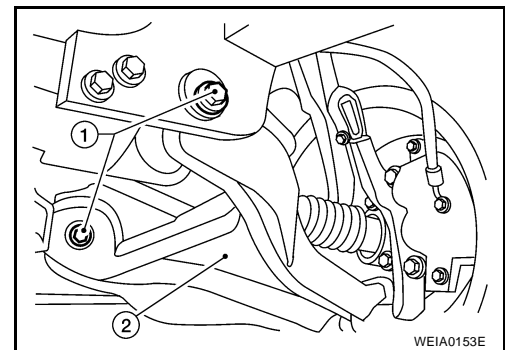

Rear cam bolt	1 In	1 Out	1 In	1 Out	0	0	1 In	1 Out
Front cam bolt	1 Out	1 In	1 In	1 Out	1 In	1 Out	0	0
Camber Degree minute (Decimal degree)	0' (0°)	0' (0°)	7' (0.12°)	- 7' (-0.12°)	3' (0.05°)	- 3' (-0.05°)	3' (0.05°)	- 3' (-0.05°)
Caster Degree minute (Decimal degree)	- 14' (-0.23°)	14' (0.23°)	0' (0°)	0' (0°)	7' (0.12°)	- 7' (-0.12°)	- 7' (-0.12°)	7' (0.12°)

3. Tighten the adjusting bolt nuts to specification. Refer to [FSU-5, "Components"](#).

TOE-IN

WARNING:

- **Always perform the following procedure on a flat surface.**
- **Make sure that no person is in front of the vehicle before pushing it.**

ON-VEHICLE SERVICE

1. Bounce the front of vehicle up and down to stabilize the vehicle height (posture).
2. Push the vehicle straight ahead about 5 m (16 ft).
3. Put a mark on base line of the tread (rear side) of both front tires at the same height as hub center as shown. These marks are measuring points.

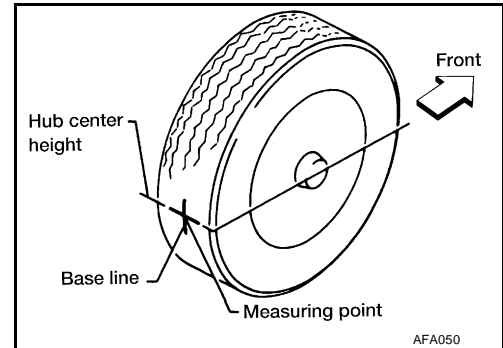

4. Measure the distance "A" on the rear side of the front tires as shown.
5. Push the vehicle slowly ahead to rotate the wheels 180° degrees (1/2 a turn).

CAUTION:

If the wheels have rotated more than 180° degrees (1/2 turn), start this procedure again from the beginning. Never push the vehicle backward.

6. Measure the distance "B" on the front side of the front tires at the same marks as shown. Total toe-in is calculated as "A" – "B".

Total toe-in : Refer to [FSU-20, "Wheel Alignment \(Unladen^{*1}\)^{*6}"](#) .

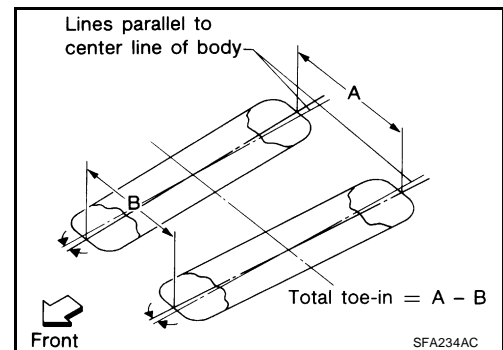

7. Adjust the toe-in by varying the length of the steering outer socket.
 - a. Loosen the outer tie-rod lock nuts.
 - b. Adjust the toe-in by screwing the outer tie-rods in or out.

Standard length "L" : Refer to [PS-34, "Steering Outer Socket and Inner Socket"](#) .

- c. Tighten the outer tie-rod lock nuts to specification.

Lock nut : Refer to [PS-17, "Disassembly and Assembly"](#) .

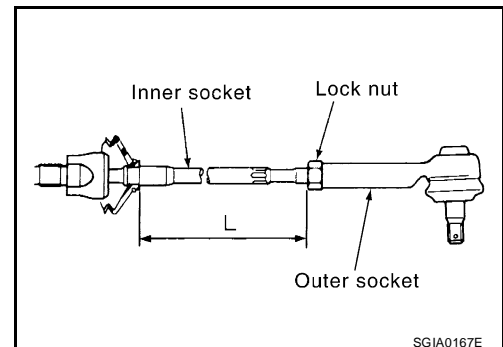

FRONT WHEEL TURNING ANGLE

NOTE:

Check front wheel turning angle after the toe-in inspection.

1. Place front wheels on turning radius gauges in straight ahead position and rear wheels on stands so that vehicle can be level. Check the maximum inner and outer wheel turning angles for LH and RH road wheels.
2. Start engine and run at idle, turn steering wheel all the way right and left, measure the turning angle.

Wheel turning angle (full turn) : Refer to [FSU-20, "Wheel Alignment \(Unladen^{*1}\)^{*6}"](#) .

- Any turning angles are not adjustable. If any of steering angles are out of the specification, check if the following parts are worn or damaged.

- Steering gear
- Steering column
- Front suspension components

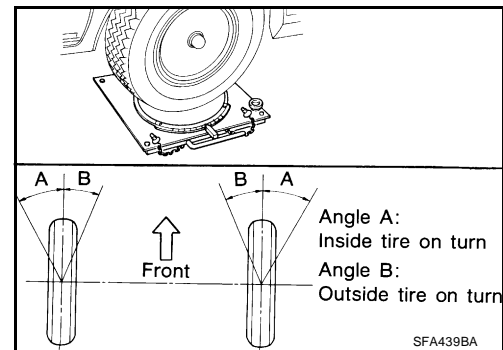

ON-VEHICLE SERVICE

If found that they are worn or damaged, replace them with new ones.

A

B

C

D

FSU

F

G

H

I

J

K

L

M

COIL SPRING AND SHOCK ABSORBER

COIL SPRING AND SHOCK ABSORBER

PFP:56210

Removal and Installation REMOVAL

EES001GK

1. Remove the wheel and tire using power tool.
2. Remove the shock absorber lower bolt using power tool.
3. Remove the three shock absorber upper mounting nuts using power tool.
4. Remove the coil spring and shock absorber assembly.
 - Turn steering knuckle out to gain enough clearance for removal.

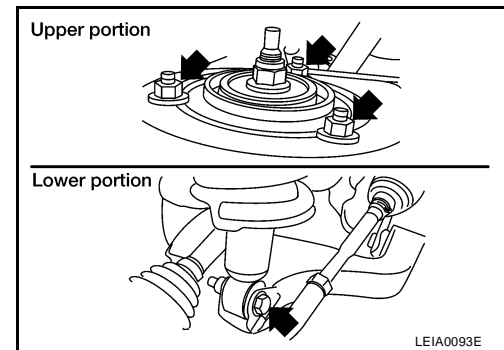

INSTALLATION

Installation is in the reverse order of removal.

- The step in the shock absorber assembly lower seat faces outside of vehicle.
- Tighten all nuts and bolts to specification. Refer to [FSU-5, "Components"](#).
- When installing wheel and tire, refer to [WT-7, "Rotation"](#).

Disassembly and Assembly DISASSEMBLY

EES001GL

1. Set the shock absorber in a vise, then loosen (without removing) the piston rod lock nut as shown.

CAUTION:

Do not remove piston rod lock nut at this time.

2. Compress the spring using commercial service tool until the shock absorber mounting insulator can be turned by hand.

WARNING:

Make sure that the pawls of the two spring compressors are firmly hooked on the spring. The spring compressors must be tightened alternately and evenly so as not to tilt the spring.

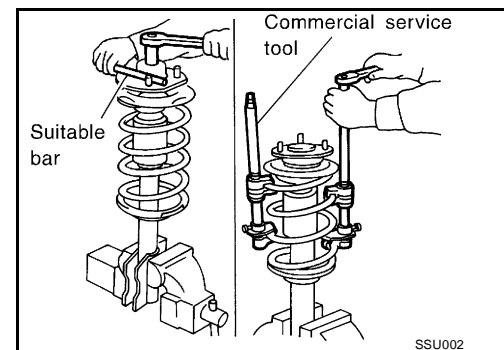

3. Remove the piston rod lock nut.
 - Discard the piston rod lock nut, use a new nut for assembly.

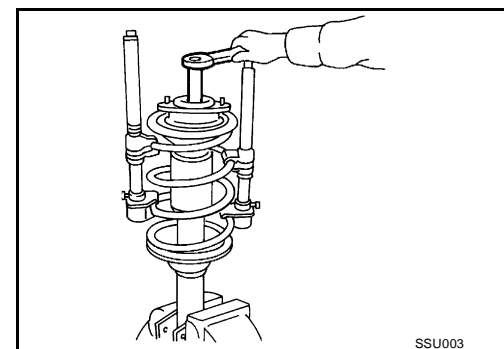

INSPECTION AFTER DISASSEMBLY

Shock Absorber Assembly

- Check for smooth operation through a full stroke, both compression and extension.
- Check for oil leakage on welded or gland packing portions.
- Check piston rod for cracks, deformation or other damage and replace if necessary.

Mounting Insulator and Rubber Parts

Check cemented rubber-to-metal portion for separation or cracks. Check rubber parts for deterioration and replace if necessary.

COIL SPRING AND SHOCK ABSORBER

Coil Spring

- Check for cracks, deformation or other damage and replace if necessary.
- Check the free spring height.

Front spring free height

4x2 : 325.5 ± 3 mm (12.8 ± 0.1 in)

4x4 : 335.0 ± 3 mm (13.2 ± 0.1 in)

ASSEMBLY

1. When installing coil spring on shock absorber, it must be positioned as shown.

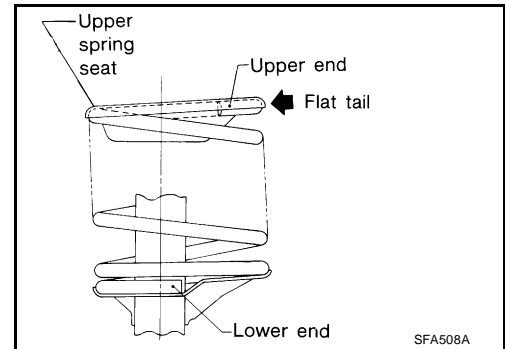

2. Install upper mounting insulator as shown in line with lower shock absorber mount and step in shock absorber lower seat.
 - The step in the shock absorber lower seat faces outside of vehicle.
3. Tighten the piston rod lock nut to specification. Refer to [FSU-5, "Components"](#).
 - Use a new piston rod lock nut for assembly.

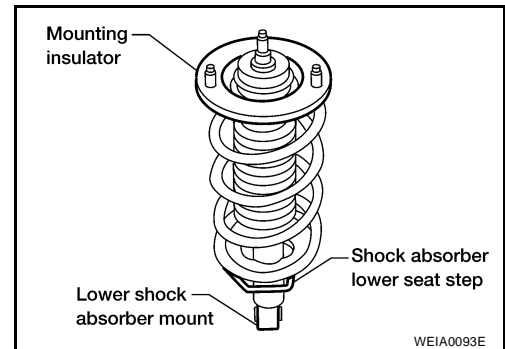

STABILIZER BAR

STABILIZER BAR

PF5:54611

Removal and Installation

EES001GM

REMOVAL

1. Remove engine under cover using power tool.
2. Remove stabilizer bar mounting bracket bolts and connecting rod nuts as shown, using power tool.
3. Remove bushings from stabilizer bar.

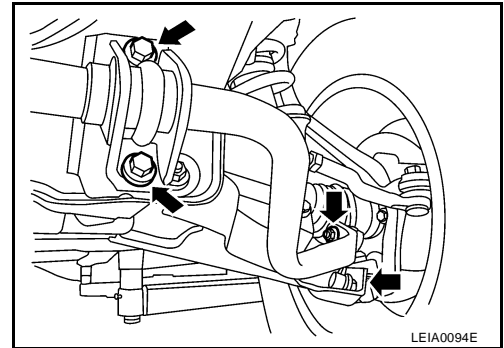

INSPECTION AFTER REMOVAL

- Check stabilizer bar for twist and deformation. Replace if necessary.
- Check rubber bushing for cracks, wear and deterioration. Replace if necessary.

INSTALLATION

Installation is in the reverse order of removal.

- Tighten all nuts and bolts to specification. Refer to [FSU-5, "Components"](#) .

UPPER LINK

PFP:54524

EES001GN

UPPER LINK

Removal and Installation

REMOVAL

1. Remove the wheel and tire using power tool.
2. Remove wheel opening shield.
3. Remove cotter pin and nut from upper link ball joint.
4. Separate upper link ball joint stud from steering knuckle using Tool.
 - Support lower link with jack.

Tool number : ST29020001 (J24319-01)

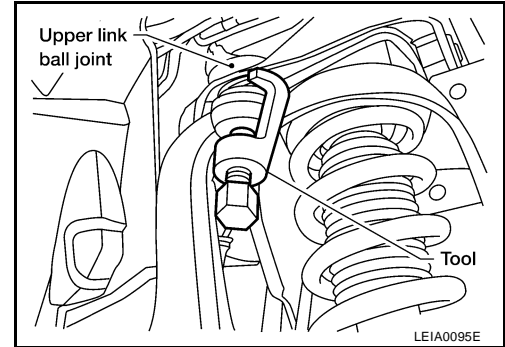

5. Remove upper link mounting bolts and nuts.

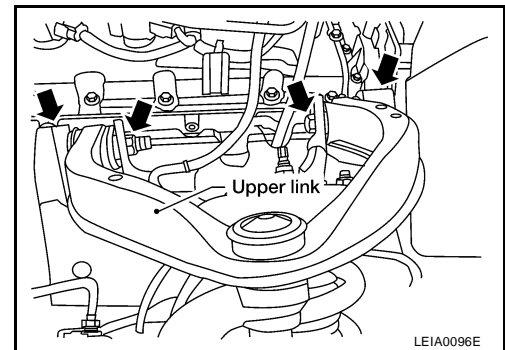

INSPECTION AFTER REMOVAL

Upper Link

Check for deformation and cracks. Replace if necessary.

Upper Link Ball Joint

Check for distortion and damage. Replace if necessary.

INSTALLATION

Installation is in the reverse order of removal.

- Tighten all nuts and bolts to specification. Refer to [FSU-5, "Components"](#) .
- When installing wheel and tire, refer to [WT-7, "Rotation"](#) .
- After installation, check that the front wheel alignment is within specification. Refer to [FSU-6, "Front Wheel Alignment"](#) .

A
B
C
D
FSU
F
G
H
I
J
K
L
M

LOWER LINK

PF5:55020

LOWER LINK

Removal and Installation

EES001G0

1. Remove the wheel and tire using power tool.
2. Remove lower shock absorber bolt.
3. Remove stabilizer bar connecting rod lower nut using power tool, then separate connecting rod from lower link. Refer to [FSU-12, "Removal and Installation"](#) .
4. Remove drive shaft, if equipped. Refer to [FAX-7, "Removal and Installation"](#) .
5. Remove pinch bolt from steering knuckle using power tool, then separate lower link ball joint from steering knuckle.

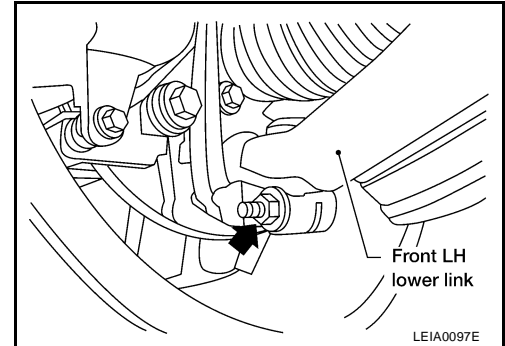

6. Remove lower link adjusting bolts and nuts, then the lower link.

NOTE:

Some vehicles may be equipped with straight (non-adjustable) lower link bolts and washers. In order to adjust camber and caster on these vehicles, first replace the lower link bolts and washers with adjustable (cam) bolts and washers.

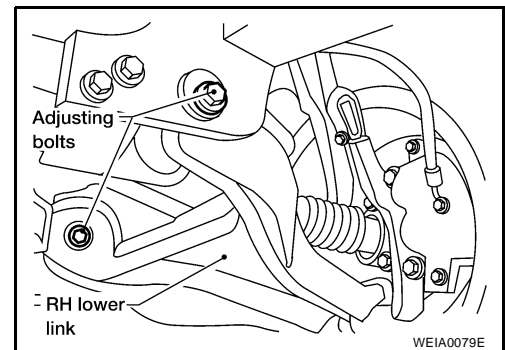

INSPECTION AFTER REMOVAL

Lower Link

Check for deformation and cracks. Replace if necessary.

Lower Link Bushing

Check for distortion and damage. Replace if necessary.

INSTALLATION

Installation is in the reverse order of removal.

- Tighten all nuts and bolts to specification. Refer to [FSU-5, "Components"](#) .
- When installing wheel and tire, refer to [WT-7, "Rotation"](#) .
- After installation, check that the front wheel alignment is within specification. Refer to [FSU-6, "Front Wheel Alignment"](#) .

UPPER BALL JOINT AND LOWER BALL JOINT

UPPER BALL JOINT AND LOWER BALL JOINT

PPF:40110

Removal and Installation

EES001GP

The ball joints are part of the upper and lower links. Refer to [FSU-13, "Removal and Installation"](#) (upper link), [FSU-14, "Removal and Installation"](#) (lower link).

Inspection

EES001GQ

- Check the ball joint for excessive play. Replace the upper or lower link assembly if any of the following exists:
- Ball joint stud is worn.
- Ball joint is hard to swing.
- Ball joint play in axial directions or end play is excessive.

SWINGING FORCE

NOTE:

Before checking the axial forces and end play, turn the lower ball joint at least 10 revolutions so that the ball joint is properly broken in.

1. Measure the ball joint swinging force using a suitable tool.
 - Measure at the cotter pin hole for upper ball joint as shown.
 - Measure at the groove for lower ball joint as shown.

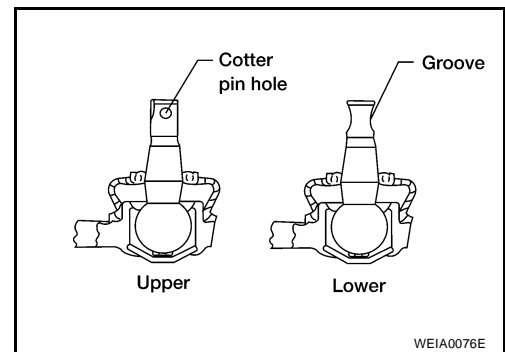

2. Verify the ball joint swinging force is within specification.

Swinging force "A"

Upper ball joint : 8.1–103.2 N (0.8–10.5 kg-f, 1.8–23.2 lb-f)

Lower ball joint : 11.4–145.5 N (1.1–14.8 kg-f, 2.5–32.7 lb-f)

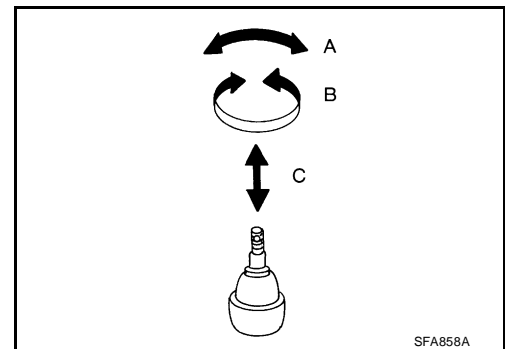

TURNING FORCE

Check the turning torque using a suitable tool.

NOTE:

Before checking the axial forces and end play, turn the lower ball joint at least 10 revolutions so that the ball joint is properly broken in.

Turning torque "B" : 0.5 - 6.4 N·m (0.05 - 0.65 kg-m, 4 - 57 in-lb)

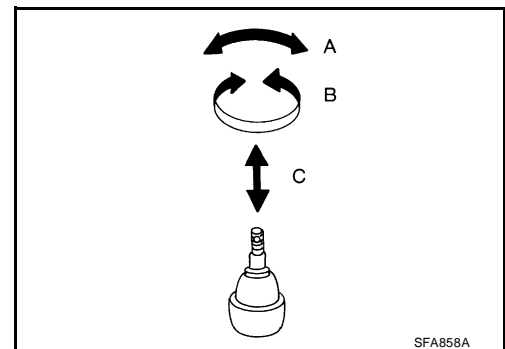

A
B
C
D
FSU
F
G
H
I
J
K
L
M

UPPER BALL JOINT AND LOWER BALL JOINT

VERTICAL END PLAY

- Measure the vertical end play using a suitable tool.
- Check dust cover for damage. Replace it and the cover clamp if necessary.

NOTE:

Before checking the axial forces and end play, turn the lower ball joint at least 10 revolutions so that the ball joint is properly broken in.

Vertical end play "C" : 0 mm (0 in)

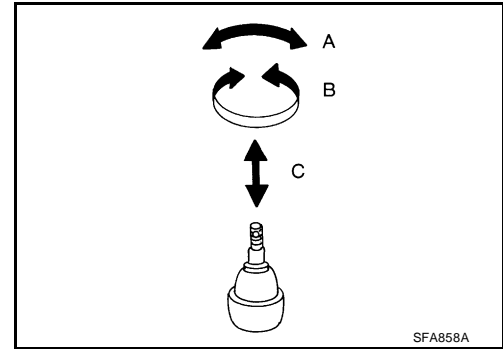

KNUCKLE

On-Vehicle Inspection and Service

EES001GR

Make sure the mounting conditions (looseness, backlash) of each component and component status (wear, damage) are within specifications. Refer to [FSU-21, "Ball Joint"](#) .

Removal and Installation

EES001GS

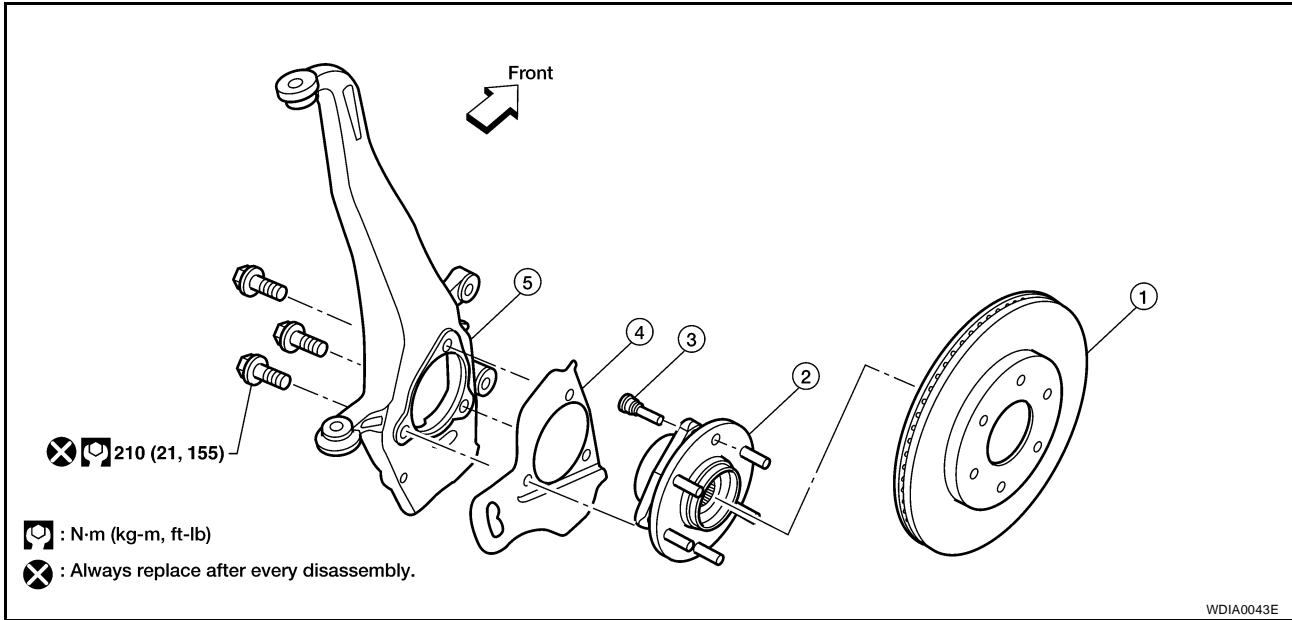

- | | | |
|-----------------|-----------------------------------|---------------|
| 1. Disc rotor | 2. Wheel hub and bearing assembly | 3. Wheel stud |
| 4. Splash guard | 5. Steering knuckle | |

REMOVAL

1. Remove wheel and tire from vehicle using power tool.
2. Without disconnecting the hydraulic lines, remove brake caliper using power tool. Reposition it aside with wire. Refer to [BR-21, "Removal and Installation of Brake Caliper Assembly and Disc Rotor"](#) .

CAUTION:

It is not necessary to remove bolts on torque member and brake hose except for disassembly or replacement of caliper assembly. In this case, hang cylinder body with a wire so that the brake hose is not under tension.

NOTE:

Avoid depressing brake pedal while brake caliper is removed.

3. Put alignment marks on disc rotor and wheel hub and bearing assembly, then remove disc rotor.

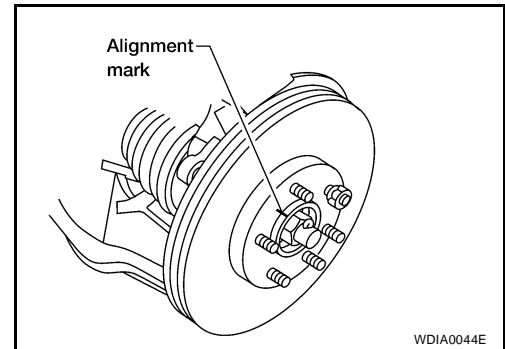

4. Remove ABS sensor from steering knuckle. Refer to [BRC-64, "Removal and Installation"](#) .

CAUTION:

Do not pull on ABS sensor harness.

5. Remove cotter pin, then remove lock nut from drive shaft using power tool.
6. Remove steering outer socket cotter pin at steering knuckle, then loosen mounting nut using power tool.

A
B
C
D
FSU
F
G
H
I
J
K
L
M

KNUCKLE

7. Disconnect steering outer socket from steering knuckle using Tool. Be careful not to damage ball joint boot.

CAUTION:

To prevent damage to threads and to prevent Tool from coming off suddenly, temporarily install mounting nut loosely.

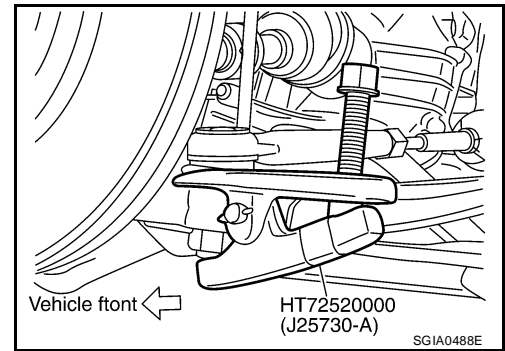

8. Remove drive shaft, if equipped. Refer to [FAX-7, "Removal and Installation"](#).
9. Remove wheel hub and bearing assembly bolts using power tool.
10. Remove splash guard and wheel hub and bearing assembly from steering knuckle.
11. Support lower link using a suitable jack.
12. Remove cotter pin and nut from upper link ball joint.
13. Separate upper link ball joint from steering knuckle using Tool.

Tool number : ST29020001 (J-24319-01)

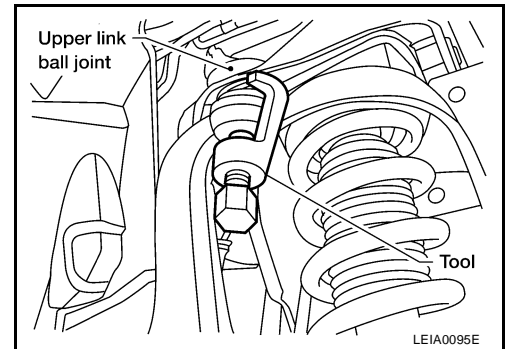

14. Remove pinch bolt from steering knuckle using power tool. Then remove steering knuckle from lower link ball joint.

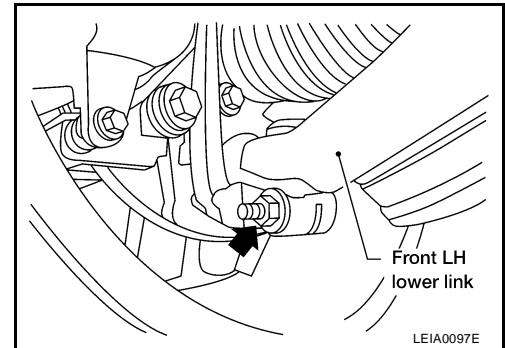

15. Remove steering knuckle from vehicle.

INSPECTION AFTER REMOVAL

Check for deformity, cracks and damage on each part, replace if necessary.

- Perform ball joint inspection. Refer to [FSU-15, "Inspection"](#).

KNUCKLE

INSTALLATION

Installation is in the reverse order of removal.

- Refer to [FSU-5, "Components"](#) for tightening torques.
- When installing disc rotor on wheel hub and bearing assembly, align the marks.
(When not using the alignment mark, refer to [BR-24, "DISC ROTOR INSPECTION"](#) .)
- When installing wheel and tire, refer to [WT-7, "Rotation"](#) .

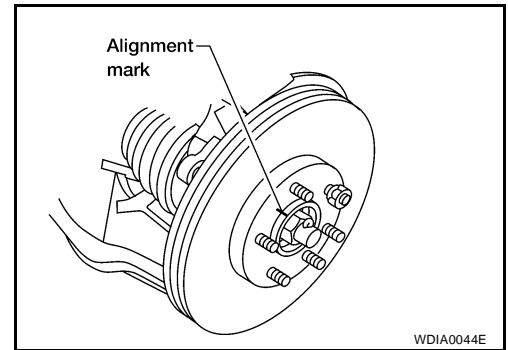

A
B
C
D
F
G
H
I
J
K
L
M

FSU

SERVICE DATA AND SPECIFICATIONS (SDS)

SERVICE DATA AND SPECIFICATIONS (SDS)

PF0:00030

General Specifications (Front)

EES001GT

Suspension type	Independent double wishbone coil over shock
Shock absorber type	Double-acting hydraulic
Stabilizer	Standard equipment

Wheel Alignment (Unladen^{*1})*⁶

EES001GU

Drive type		4x2	4x4
Camber Degree minute (decimal degree)	Minimum	-0° 51' (-0.85°)	-0° 33' (-0.55°)
	Nominal	-0° 6' (-0.10°)	0° 12' (0.20°)
	Maximum	0° 39' (0.65°)	0° 57' (0.95°)
	Cross camber	0° 45' (0.75°) or less	0° 45' (0.75°) or less
Caster Degree minute (decimal degree)	Minimum	3° 15' (3.25°)	2° 45' (2.75°)
	Nominal	4° 0' (4.00°)	3° 30' (3.50°)
	Maximum	4° 45' (4.75°)	4° 15' (4.25°)
	Cross caster	0° 45' (0.75°) or less	0° 45' (0.75°) or less
Kingpin inclination Degree minute (decimal degree)		13° 32' (13.53°)	13° 13' (13.22°)

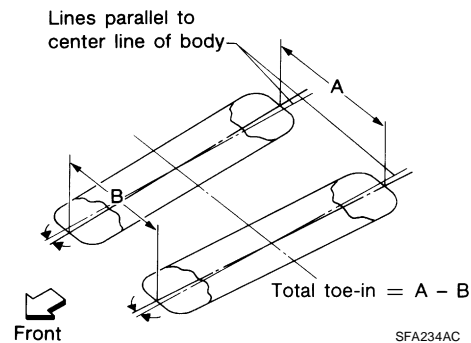

Total toe-in	Distance (A - B)	Minimum	1.8 mm (0.07 in)	1.8 mm (0.07 in)
		Nominal	2.8 mm (0.11 in)	2.8 mm (0.11 in)
		Maximum	3.8 mm (0.15 in)	3.8 mm (0.15 in)
	Angle (left side and right side) Degree minute (decimal degree)	Minimum	0° 3' (0.05°)	0° 3' (0.05°)
		Nominal	0° 5' (0.08°)	0° 5' (0.08°)
		Maximum	0° 7' (0.12°)	0° 7' (0.12°)
Wheel turning angle (full turn)	Inside Degree minute (decimal degree)	34° 31' - 38° 31' *2 (34.52° - 38.52°)	34° 44' - 38° 44' *4 (34.73° - 38.73°)	
	Outside Degree minute (decimal degree)	30° 59' - 34° 59' *3 (30.98° - 34.98°)	30° 29' - 34° 29' *5 (30.48° - 34.48°)	

*1: Fuel, radiator coolant and engine oil full. Spare tire, jack, hand tools and mats in designated positions.

*2: Target value 37° 31' (37.52°)

*3: Target value 33° 59' (33.98°)

*4: Target value 37° 44' (37.73°)

*5: Target value 33° 29' (33.48°)

*6: Some vehicles may be equipped with straight (non-adjustable) lower link bolts and washers. In order to adjust camber and caster on these vehicles, first replace the lower link bolts and washers with adjustable (cam) bolts and washers.

SERVICE DATA AND SPECIFICATIONS (SDS)

Ball Joint

EES001GV

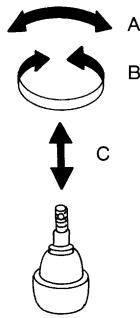

SFA858A

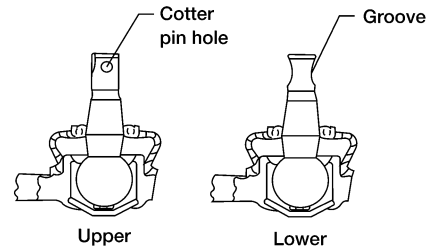

WEIA0076E

Swinging force "A"	Upper ball joint	8.1 – 103.2 N (0.8 – 10.5 kg-f, 1.8 – 23.2 lb-f) *1
	Lower ball joint	11.4 – 145.5 N (1.1 – 14.8 kg-f, 2.5 – 32.7 lb-f) *2
Turning torque "B"		0.5 - 6.4 N·m (0.05 - 0.65 kg-m, 4 - 57 in-lb)
Vertical end play "C"		0 mm (0 in)

*1 Measure at cotter pin hole

*2 Measure at groove

Wheelarch Height (Unladen*1)

EES001GW

Unit: mm (in)

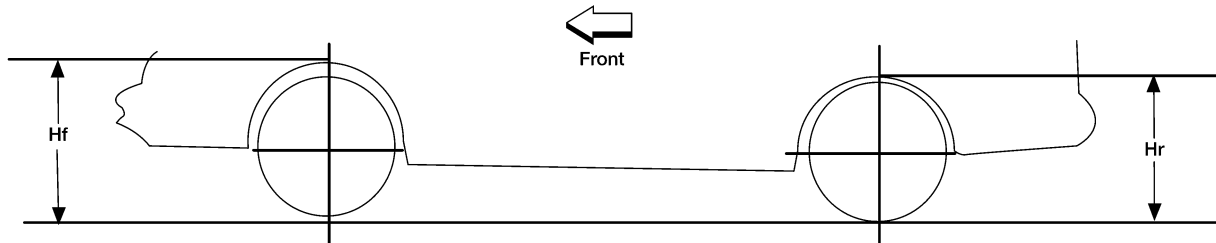

LEIA0085E

Suspension type	Air leveling*2	
	4x2	4x4
Applied model	4x2	4x4
Front wheelarch height (Hf)	913 (35.94)	931 (36.65)
Rear wheelarch height (Hr)	912 (35.91)	932 (36.69)

*1: Fuel, radiator coolant and engine oil full. Spare tire, jack, hand tools and mats in designated positions.

*2: Confirm level using Consult-II, register 1103. Set rear wheel arch height to "0" if necessary.

SERVICE DATA AND SPECIFICATIONS (SDS)
